



505.73

14

14855

SCIENCE

389
1889

AN ILLUSTRATED JOURNAL

PUBLISHED WEEKLY

VOLUME XIII

JANUARY—JUNE 1889



NEW YORK
N. D. C. HODGES

1889

INDEX TO VOLUME XIII.

- Academy of Science elections, 321; papers, 320.
 Accumulators, 2 7.
 Acropolis, 41.
 Advertising by doctors, 137.
 Africa, 42; discoveries in Central, 442; resources of, 6 4.
 Agassiz, Augustus, 5.
 Agricultural map of America, 178; stations, utility of, 219.
 Allen's English Restoration and Louis XIV., 127.
 Alloy, a new, 2 9.
 Aluminum manufacture, 260, 499.
 Analysis of air and war, 175.
 Anatomical memoranda, 158.
 Andrews and Stoddard's Grammar of the Latin Language, 12.
 Anemometer constant, 204; factor, 248; the Robinson, 268, 269, 367.
 Anthropological Society, Women's, 60, 240.
 Anti-friction metal, 392.
 Antiquarian Society, 340.
 Antlers, clustered, 321.
 Archeological expedition, Hemenway, 8.
 Archeology of District of Columbia, 38.
 Archery, national school of, 478.
 Arch ramp, 255, 266.
 Arctic exploration, 101.
 Arnold's Reports on Elementary Schools, 1853-82, 324.
 Arsenic in fabrics, 119.
 Art, pre-Columbian, 113; schools of the Metropolitan Museum, 140.
 Asphaltenes, 498.
 Asphyxiation by illuminating-gas, 437.
 Association for the Advancement of Science, 139, 479.
 Autobion monument, 13.
 Austen's Chemical Lecture Notes, 223.
 Australian exploration, 441.
 Baconian method in science, 112.
 Bacteria in the glaciers, 119.
 Baking powders, 296, 423.
 Baldness, 176.
 Balloon, 78.
 Balzac's Louis Lambert, 65; Sarahpita, 507.
 Barnard, President A. T., death of, 338.
 Battle on the Battle of the Swamp and the Capture of Canada, 13.
 Base-line, Los Angeles, 157.
 Batteries, Julien storage, 13; new secondary, 35; secondary, 274, 366, 436; storage, for street-cars, 331.
 Battery, Axa, 101; Clark, 297; Detroit secondary, 297; Macneon, 194.
 Beans in prehistoric Arizona, 233.
 Beer production, 349.
 Bell, a new Mountain of the, 362.
 Bellise, 156.
 Bennett and Murray's Hand-Book of Cryptogamic Botany, 408.
 Benzole acid in beers, 440.
 Bernheim's Suggestive Therapeutics, 265.
 Bessel's Psychic Life of Micro-organisms, 185.
 Binger, Capt., explorations of, 404.
 Birds, Cucullaris propatagialis in oestrine, 16; destruction of, 441; soaring of, 15, 31, 71, 151, 169, 187, 201, 245.
 Births, triple, 110, 132.
 Bismuth, voltaic current from, 398.
 Blavatsky's The Secret Doctrine, 89.
 Boats, nitrous oxide, 155.
 Boats, wild, 237.
 Boaz, submarine, 59, 300.
 Bolders, design of, 321.
 Book-keeping, the decline of, 260.
 Bore in Hangchow Bay, 328.
 Boston Society of Natural History officers, 341.
 Bowditch's Hints for Teachers of Physiology, 368.
 Brake, electric, 411, 439.
 Brick-work, strength of, 181.
 Bridge, submarine, 500.
 Bridgman, Laura, death of, 421.
 British Columbia, mineral wealth of, 436; notes from, 364.
 Broch, O. J., death of, 180.
 Bronze, Tobin, 320.
 Browning's Aspects of Education, 25.
 Brown's Treatise on Spherical Trigonometry, 468.
 Buds, Pests, unhealthiness of, 421.
 Building-stones of East Texas, 295.
 Bulgarian population, 380.
 Butter-making, 328.
 California, colonization of Lower, 255.
 Calorimetric experiments, 379.
 Canal, Corinth, 359, 401; Manchester ship, 181.
 Canal-locks, propulsion, 278.
 Canal-lifts, 481.
 Cancer contagion, 437.
 Carus's Fundamental Problems, 484.
 Cases's Physical Realism, 165.
 Cass's Treatise on Spherical Trigonometry, 468.
 Census machine, electrical, 20; the next, 442.
 Chambers's Encyclopaedia, 285.
 Characters, inheritance of, 236.
 Chemical experiment, 449; re-actions, 240; society, 462; study of apple-twigs, 481.
 Cherokees, the Eastern, 120.
 Chevrolat, Michel Eugene, 271; funeral of, 431.
 Child-labor, 121.
 Chimney corrosion by wood soot, 460; draught, 358; repai-rer, 439.
 Chinch-bug in Arkansas, 441; in Illinois, 275.
 China-treaty, 387.
 Chrome yellow as a poison, 347.
 Church's Mechanics of Engineering, 468.
 Churches, paper, 430.
 Cicada, periods, 358.
 Clark University, 321, 360, 462.
 Classics and Moderns, strife of, 480.
 Claus's Elementary Text-Book of Zoology, 448.
 Clintonite, 370.
 Clouds, vapour, 441.
 Cloud and fog, 487.
 Cloud burst, 459.
 Coal-questions in England, 1-3.
 Coal-bigger, for, C. C. 250.
 Coal mining machines, electrical, 2.
 Coals, Kansas, 217.
 Coasts of the Baltic, secular rising of the, 461.
 Cobra, skin in, 237.
 Coffee adulteration, 400; artificial, 328.
 Colgate University, 501.
 College admision, 358.
 Colorado climate, 174.
 Color-blindness, 32, 41, 170.
 Com-bustion, spontaneous, 277.
 Com-position, curves of, 92.
 Congress, agricultural, 1890, 437; anthropological, 141, 339; botanical, 281; electrical, 312; labor, 400; philosophical, 320; sanitary, 321; zoologicals, 320.
 Congresses at Paris, 361, 381.
 Connecticut Fundamental Orders of, 90.
 Consumption, 482; contagiousness of, 137, 162; germ theory in, 3; prevention of, 462, 465.
 Conyers's Marriage and Divorce in the United States, 304.
 Copper, price of, 253.
 Copyright, international, 102.
 Coral islands, origin of, 236.
 Cory's Hypnotism or Mesmerism, 50; The Birds of the West Indies, 65.
 Cotton fabric, 251.
 Crane's La Société Française au Dix-septième Siècle, 507.
 Crematory, the Hughes, 477.
 Criminals, insane, 340.
 Crops in C. Hornia, 499.
 Cruiser, submerging monitor, 229.
 Cruisers, the two-houson ton, 471.
 Cucumber disease, 380.
 Cures, psychic, 406.
 Dairy commissioner of New Jersey, report of, 366.
 Dan, Robt., death of, 401.
 Dance, Blackfoot sun, 215.
 Dann's German Commercial Correspondence, 148.
 Date-stamp, elect ic, 160.
 Deane, Robert, the leading Book, 149.
 Deaf, study of, 392; teaching language to, 402.
 Deaf-mute instruction in Cincinnati, 482.
 Deaths by lightning, 369; of English scientific men, 324.
 Defective classes, census of, 38.
 Degeneration of the race, 57.
 De Guimps's Pestalozzi, 445.
 De la Rue, Warren, death of, 359.
 Deuver formation, size of the, 250.
 Deodorant, a new, 119.
 Derelict schooner "W. L. White," 117.
 Dines, P. Jessor John, appointment of, 321.
 Dialect Society, 322.
 Dictionary, science and the, 103.
 Diphtheria, 215, 257, 318; transmission of, 119.
 Diseases of menagerie animals, 30.
 Disinfectant, mercuric chloride as a, 62.
 Disinfectants, 61.
 Distilleries in Russia, 380.
 Dollinger, Ignatius, 360.
 Draper memorial, 322.
 Drowning cases, 421.
 Dues and strength, 326; purity of, 218.
 Du Bois-Reymond, Dr. Paul, death of, 360.
 Dupuis's Elementary Synthetic Geometry, 468.
 Dyeing and bleaching laboratory, 141.
 Dynamite gun, 56, 82.
 Dynamo, a new, 326; designing, 235; the Continuum, 17; Westinghouse, 451.
 Earthquake in Japan, 500; in Liguria, 143; in Pennsylvania, 268.
 Eclipse of Jan. 1, 7.
 Economic Association, '68.
 Edison's works, 161.
 Education, encouragement of higher, 219; in Germany, primary, 458; in India, 481; in Russia, 401; of child widows in India, 358.
 Educational Museum for Texas, 101.
 Egypt, races of, 159.
 Elder, the, 181.
 Eiffel, Gustave, 406.
 Eiffel Tower, height of, 350, 499.
 Electric apparatus, the Clark, 494; conductor, a large, 230; conduit system, 372; course at Columbia, 378; currents by mechanical action, 101; distribution, 81; door-opener, 294; drawbridge, 312; engineering at Columbia, 81, 901; Light Association, 4, 154, 460; light on the eyes, 367; lighting by small engines, 2-6; lighting in Europe, 337; oscillations, Hertz on, 79, 98, 137; power in mines, 473; power station, 251; regulator, Wagner, 27; system, Bentley-Knight, 373; system, Sperry, 192; system, Western, 351; tramway in England, 259; underground system, 433; welding, 437.
 Electricity and ether, 109; and light, 158.
 Electroplating glass and porcelain, 500.
 Elephant, skeleton of large, 421.
 Elevator stop, 237.
 Elroy's Annual Report, 102.
 Elizabeth Thompson Science Fund, 461.
 Emin Pasha, 24, 238.
 Empire, our future, 38.
 Energy, conservation of, 400.
 English Westinghouse, 355; working at a fixed cut-off, 440.
 Entomological Club, 479.
 Ericsson Coast Defence Company, 236.
 Ericsson, John, 139, 159, 299.
 Error, genesis of, 164.
 Essex Institute, Salem, 279.
 Ether and the earth's atmosphere, 390.
 Ethnological comparisons, 159.
 Ethnology, report of Bureau of, 64.
 Examination and education, 323.
 Examinations, English, 309.
 Excavations at Paris, 159; by freezing, 274.
 Excelsior classes in Australia, 342.
 Exhibition, geographical, 240; graphic, at Stuttgart, 281; in Birmingham, 281; international novelties, 406; Paris, 1889; Paris, United States of the, 142; travelling platforms in the Paris, 401.
 Exhibitions, floating, 380.
 Feldspar, or feldspar, 16.
 Fertilizer analyses, 439.
 Filters, 437.
 Fire alarm, 191; brigade in Paris, 197.
 Fish in isolated waters, 16, 225; Commission experiments, 60.
 Flowers, double, or factually produced, 441.
 Fly as a disease-carrier, 506.
 Flying-ship, 237.
 Fly-wheels, 467.
 Fog, 116, 429; dissipation of, by electricity, 59.
 Food analysis, 214; decomposing, 483; inspection, 196; requirements of man, 360.
 Footnotes, 380.
 Force, lines of, 234.
 Forests, Adirondack, 218.
 Fossil wood, 11.
 Franklin Institute awards, 298.
 French Association for the Advancement of Science, 140.
 Fruits, 360.
 Fruit-trees in southern California, 321.
 Fungi, study of, 360.
 Galton's Natural Inheritance, 366.
 Gallie and Kutter's General Formula for the Uniform Flow of Water in Rivers and Other Channels, 302.
 Garbage-disposal, Fledschmann system of, 115.
 Gas, natural, 119 in Ohio, 215.
 Gaslight, improved, 96.
 Gas-spring, a deadly, 130.
 Geese, long memory of, 400.
 Geographic Society, 11; teaching, 317.
 Geological Society of America, 8, 400; Survey, 20; Survey report, 342; Survey of Nebraska, 61; Survey of New Jersey, 452.
 Geography, small, for teach, 305, 226, 269.
 Ge. sets, soaping, 282.
 Gibson's Text-Book of Elementary Biology, 222.
 Gilman's Profit Sharing between Employer and Employee, 328.
 Glaciation in Greenland, 121; of Canada, 399.
 Glass, conductivity of, 60.
 Glycerine for sharpening edge tools, 461.
 Gold producer, 187.
 Gosse's History of Eighteenth Century Literature, 259.
 Gould's ornithological works, 387.
 Gratings, theory of, 419; use of, 418.
 Greek Statics for Beginners, 481.
 Greek temple painting, 181.
 Greenhouses, warming, 359.
 Greenland expedition, 501; Dr. Nansen's journey across, 439, 477.
 Greenlanders, East, 384.
 Gum-arabic, artificial, 361.
 Gun, pneumatic, 151.
 Gunpowder, a new, 298.
 Guns, modern, st of, 328; quick-firing, 298.
 Hamilton's Text-Book of Pathology, 445.
 Harper's First, Second, Third, and Fourth Readers, 285.
 Harvard College, vote of officers of, 101.
 Health a public duty, 298; association, 505; Bureau of, 10; National Board of, 215; report of the New Hampshire State Board of, 60; report of New York, 478; report of New Jersey, 345; report of New York, 304; report of Providence, 466.
 Heat, sources of, 329, 349.
 Heating and ventilating, 334.
 Hemenway expedition to the Everes, 29.
 Henshall's More about the Black Bass, 13.
 Historical Association, 7.
 Holbrook's Eating for Strength, 12.
 Home Gymnastics for the Well and the Sick, 435.
 Home study, 480.
 Horns of the prong-buck, 70.
 Horse-flesh as food, 422.
 Humphrey's Favorite Authors for Children, 11.
 Hurricanes, West India, 254, 339, 424.
 Hypnotism, German works on, 125.
 Ice water, 506.
 Incandescent lamps, efficiency of, 435.
 Indian relics from Florida, 61; from North Carolina, 92.
 Indiana Academy of Science, 7, 338.
 Induction coil, 252.
 Industrial tabeaus, 301.
 Inebriate-asylums, 159.
 Inebriety, Association for Study of, 7.
 Insecticides, 357, 393.
 Insomnia, 367.
 Iron industry in the Southern States, 11; silicated, 238; smelting in China, 300.
 Irrigation in California, 110; survey for, 61.
 Ivory varnish, 332.
 Jacob's Physiological Notes on Primary Education and the Study of Languages, 367.
 Jade in Alaska, 88; question, 121.

Janau's French Commercial Correspondence, 148.
Johns Hopkins Hospital, 149, 217.
Johns Hopkins University anniversary, 139; needs, 162.
Kangaroo extinction, 480.
Kansas Historical Society, 140.
Katydid, color of, 32, 71.
Ketchum's Botany for Academies and Colleges, 239.
Kidder, J. H., death of, 321.
Kilmas Ndjaro, 324.
Kilogram, alloy of the standard, 399.
Kirk's When Age Grows Young, 133.
Klein's Bacteria in Asiatic Cholera, 446.
Klein's Elements of Machine Design, 89; Gear Tables for lay-out of accurate Tooth Profiles, 89.
Kongo, commerce on the, 20; European vegetables of the, 261; French, 11.
Koreans, habits of, 230.
Labor in Russia, 474.
Laboratory, Marine Biological, 301, 303.
Lake basins of the St. Lawrence, 32.
Lakes of St. Joaquin valley, 503.
Language, an international, 241.
Languages, bibliography of the Iroquoian, 157.
Laurie's Occasional Addresses on Educational Subjects, 201.
Lead-polluting, 319.
Leffmann and Beam's Examination of Water for Sanitary and Technical Purposes, 446.
Legal regulation of medical practice, 136.
Leland Stanford in 1904, diversity, 399.
Letters, frequency of, 448.
Levmore and Dewey's Political History since 1815, 166.
Light jar discharge, 258.
Leyden Museum, 320.
Libraries, circulating, 175; public, medical, 137.
Lietze's Modern Heliographic Processes, 13.
Life of man and woman, 280.
Light and electricity, 327; and magnetism, 273; electric, Edison patents for, 23, 130; electric, in land warfare, 23; electric, in the Patent Office, 25; Loomis electric system, 229; velocity of, 193; without heat, 34.
Lighting, Ball electric, 18; Westinghouse electric, 1. Lightning-conductors, earthing of, 319.
Lignite industry in Ohio, 274.
Lime, origin of phosphate of, 144.
Lime-burners and consumption, 258.
Lock's Elementary Statics, 470.
Locomotive, a double, 430; electric, 233; Strong, 438.
Locomotives, compound, 320; soda, 420.
Loco weed, 176.
London from a sanitary point, 153.
Lougman's New Atlas, 283.
Lucas's Geography of the British Colonies, 166.
MacDowall's Curve Pictures of London for the Social Reformer, 327.
Magnetic action of currents, 235; storms, 347.
Magnetism and sunspots, 141.
Malaria, 119; microbe, 173.
Man of Nip, 232.
Manganese, preparation of, 504.
Manual training in the conditions of, 22.
Marriage ceremonies of the Bilqua, 505.
Marsh vegetation, 5 0.
Martin and Wetzler's Electric Motor and its Applications, 446.
Massachusetts Agricultural College, 341; Institute of Technology building, 400.
Mad and the Roman Catholic Church and the School Question, 23.
Measles in Scotland, 262.
Merriman's Treatise on Hydraulics, 201.
Meteorological exhibition, 230.
Metric system, 273, 292.
Mexico, exploration in, 265.
Mica and tin ores, 481; as a lubricant, 439; conductivity of, 298.
Michelson, Albert A., presentation of Rumford medals to, 281.
Micro-organisms in inflammation, prize for essay on, 469.
Milk, poisonous, 86; supply, 175.
Mill, an acoustic, 214.
Mineral products of the United States, 455.
Mineralogical Club, New York, 182.
Minerals and synonymies, 438.
Mines and metallurgy congress, 351; electric motors for, 60, 195.
Mining industries in Siam, 184.
Models, deep sea, 191.
Molar, supermagnetic, in man, 16.
Montgomery's Leading Facts of French History, 388.
Morphine habit, 277.
Motor, alternating current, 305; C. & C. electric, 153, 341; the Denison, 211; the Tesla, 323.
Motors for balloon experiments, 133.
Mound in Calhoun County, Ill., 349.
Mound-builders, 123.
Mounds, empty, 187; of Ohio, 110.
Mushrooms, edible, 453.
Music, teaching girls, 482.
Myths of China, 123.
Nails from scrap-iron, 298.
Naptha as fuel, 500.
Naturalists, Society of, 23.
Navajo industries, 89.
Navy, electric plants in the, 100.
Newell's Outlines of Lessons in Botany, 403.
Niagara Canal 122.
Nichol's Francis Bacon, his Life and Philosophy, 327.
Nickel, magnetic properties of, 23.
Nineteenth Century Club, New York, 459.
Nitrogen in soils, 361, 400.
Norway, ancient population of, 311.
Nurses, mortality among, 276.
Obesity, treatment of, 297.
Objectives of short working distance, 140.
O'Brien's Laboratory Guide in Chemical Analysis, 463.

Observatory, a popular, 109; at Arlington, 61; at the Vatican, 483; at Hill, 321.
Ocean currents, 438.
Oham, statue to, 181.
Oil on water, 10.
Oil-bearing territory, 299.
Oils, solid matter in, 338.
Olliphant's Scientific Religion, 148.
Omaha, habits of, 60 153.
Optium-poisoning, 430.
O'Reilly's Greenland, 150.
Ores of Nickel Mountain, 10.
Oriental Society, 139.
Osteological notes, 488.
Overcoats, 175.
Ozokerite, 280.
Paris, sanitary condition of, 422.
Pasteur Institute, 87.
Pasteur's method, 3.
Patents in Japan, 361.
Paul's Principles of the History of Language, 506.
Paving, India-rubber, 101; steel, 237.
Paving-brick, 335.
Peabody Museum, 4 7.
Peas, quality of, 340.
Penicillin, corporal, 216.
Pepper plant, 410.
Perfume flower farming, 481.
Permian rocks of Texas, 92.
Petroleum as a fuel, 249; as an illuminant, 180; in Pennsylvania; vapor and air, 280.
Phantom portraits, 400.
Philosophical Society, 11.
Photograph developing, 437.
Photograph production, 401; washing-dishes, 501.
Photographs of true chromatic value, 401.
Photography and its possibilities, 371.
Physic, 280.
Physiological Association, 6.
Pile-driving by water jet, 437, 500.
Platinum, 232; in British Columbia, 290; in place, 290.
Plumbing, sanitary, 137.
Poison, whiskey as antidote for rattlesnake, 338.
Polar explorations, 240.
Postage stamp, danger in the, 137.
Potato, dried, 277.
Pottery days of Texas, 293; industry in the United States, 136.
Powder, Heughe's, 359.
Precious stones, American, 236.
Preyer's Development of the Intellect, 166.
Princeton College girls, 293.
Proctor's Student Atlas, 305.
Prunes in France, 210.
Psychos and science, 33.
Quarantine conference, 296.
Quartz as an insulator, 366; in eruptive rocks, 232.
Rabbit pest in Australia, 258.
Race between pigeons and bees, 3 8.
Railway accidents, 300; Alleghe electric, 35; Asheville electric, 80; Atlantic City electric, 80, 493; blizzard on electric 50; Boston electric, 80, 493; collisions, 281; Daft electric, in Cincinnati, 391; Daft motor on, 23; electric, for Chattanooga, 3; electricity on New York elevated, 133; Jullien electric, 30; rail, White's, 296; Reckenza electric, 80; St. Joseph electric, 232; snow-storms on electric, 80; Sprague electric, at Reading, 116; Topeka electric, 319; White electric, 33.
Railways, cable, 413; electric, 173, 212; electric, in China, wires for, 397; in Central Asia, 161; in China, 375.
Rainfall and latent heat, 369; of the Pacific slope, 457.
Ran for war-ships, 496.
Rame, 75, 489.
Rat catching, 338.
Rattlesnake's rattle, 3 5.
Rau's Psychology as a Natural Science, 314.
Research in Bombay, 401, 489.
Resistance of mercury, 195.
Rheumatism, 258.
River pirate, 108; pollution in Connecticut, 502.
Roof-g, 309.
Rose, a large, 420.
Rose Polytechnic Institute, 117.
Royal Society, Canada, 296.
Runk's Elements of Plane Analytic Geometry, 149.
Russell's process s. Bower-Barff, 363.
Salomon's The Slidj in the Service of the School, 25-Samoa, 85.
Sanborn's Go to the Ant and Learn Many Wonderful Things, 488.
Sanitarium among cow-stables, 309.
Sanitary ceilings, 497; precautions in Florida, 10.
Sanderson's Insects Injurious to Fruits, 239.
Sawdust explosion, 182.
Scarlet-fever, 318.
School, technical, in Paterson, 259.
Schoolroom as a factor in disease, 21; space, 277.
Schools, military and naval, in China, 435; of New Jersey, 82; New York, 42, 102, 122; New York, political influence in, 62; science in, 182.
Science at Cambridge, Eng., 331; teaching in England, 278.
Sechometer, Ayrton and Perry's, 319, 369; new form of, 213.
Seed-trade in California, 440.
Sense-associations, 105.
Sewage purification, 279.
Shad, Atlantic, 237.
Sheet metal from the molten state, 430.
Ship, a fire-masted, 236; Halfway, Tehuantepec, 839.
Ships, corrosion of steel, 338.
Shortsightedness in the young, 481.
Sight, fatigue of, 41.
Signalling among primitive peoples, 121.
Silk, artificial, 421; culture in California, 338; industry in Greece, 321.

Silk-worms in Germany, 337.
Silver, electro chemical equivalent of, 398.
Simoon, sandy, in the North-west, 441.
Skating, hum of, 197.
Skull hardened by sun exposure, 19.
Sleep and dreams, 87.
Society, Manual Training in Elementary Schools for Boys, 25.
Small-pox suppression, 273.
Smoke cloud, weight of, over London, 441.
Smoke, bacteriology of, 319; microscopic examination of, 341.
Snow-bloom, electric, 213.
Snow-excavator, 332.
Snowfall, an international, 830.
Sorghum sugar, 196.
Sorghum, influence of atmosphere on, 6; map of, 142.
Speech and alphabetica, 104.
Spider bite question, 414.
Spirit in prime movers, 433.
Spontaneous generation theory, 181.
Stanley, G.; and Cooper, J. G.; expedition, 123, 502; explorations of, 302; news from, 282.
Starck's Primitive Family in Its Origin and Development, 407.
Starr's Hygiene of the Nursery, 454.
Stars, aberration of, 101; variable, 340.
Steam-engine, future perfection of, 91; Ideal, 18.
Steam-engines, oil-burning, 73.
Steel, color of, 399.
Steele's Hygienic Physiology, 405.
Stirling system, direct power, 231.
Stock's Deductive Logic, 283.
Stones, in esecration of, 196.
Storm of March, 1888, 124.
Storm, velocity of, 246.
Style, curves of literary, 226, 246, 269.
Sun-dial, a new process, electric, 22.
Suggestions, negative, 41.
Sulphur fumigation, 277.
Summers and winters, 459.
Sun-dial, a new process, electric, 22.
Survey of arid region, 139; Rhode Island, 123.
Surveys, 307.
Swine or man, 175.
Talmage's First Book of Nature, 446.
Taste, sense of, 41.
Tattoo marks, 353.
Temperature instruction, 215.
Testing-machine, Gray's, 84; the Riehle, 115.
Thompson's Social Psychology, 196.
Thomson's Popular Lectures and Addresses, 184.
Thorpe's Government of the People of the United States, 222.
Thunder in Oregon, 460.
Tides, 311.
Timber, keeping moisture out of, 399.
Tobacco, use of, 258.
Tobacco-smoking, 267.
Tornadoes, 83, 105, 130.
Torpedo-boats, 197, 212, 280.
Transformers, 235.
Transfer of moisture on, 176; felling, by electricity, 196.
Tuberculosis, bacillus, 139; contagion, 319, 379.
Tunison's Master Virgil, 127.
Tunnel, the Engel Channel, 339.
Type-setting machine, 56; Thorne, 93.
Typoid statistics, 119.
Units, electrical, 366.
University, celebration of Georgetown, 181; of Minnesota, 296; students, number of, 481; teaching, for London, 421.
Vaccination discussion in England, 383.
Vacuum an electric conductor, 35.
Van's Healing Question, 50.
Vegetation in England, 7.
Venn's Principles of Empirical, or Inductive, Logic, 341.
Ventilation, 266.
Veterinary Society of Natural History, 238.
Vienna Medical School attendance, 401.
Visual images, 177.
Voltmeter, the new Weston, 97.
Voltmeters, Ayrton and Perry's, 293.
Walls, efflorescence on, 351, 300.
War, Wolsley on modern, 197.
War vessels, diagram of, 120; launched, 229.
Washington, composite portraits of, 311; signature of, 316.
Water and bacteria, 506; contagion in, 196; filtration, 71, 432; microscopic examination of, 132; and mud, 170, 205; problem of New York, 308.
Wave lengths, 279.
Weather, dew-point and predictions of, 70; forecasts, 24; reports, 342; service, 164; service at Michigan, 379; services, State, 20.
Weeds in Wisconsin, 280.
Welch's The Teacher's Psychology, 110.
Wells, deep, 401.
Westinghouse and United States Companies, 61.
Whirlwinds, 279.
White, Z. L., death of, 42.
Whitney, Professor W. D., honors to, 429.
Whitmore's Australian Ball System, 123.
Whitwell's The Weir Technology, 166.
Wind, the helm, 181.
Wind-pressure, 171, 205, 236; and velocity, 440; on wings, 217.
Winds, California, 254.
Women's breathing, 436.
Wood, chemical properties of, 398.
World-English, 359.
Wording, English, 134.
Writing, secret, 460.
Yellow-fever, 131; in Florida, 367.
Young's Text-Book of General Astronomy, 125.
Zeiss, Carl, death of, 110.
Zircon, separation of, from sand, 340.
Zoological garden in Washington, 61, 110, 481.

SCIENCE

SEVENTH YEAR.
VOL. XIII. No. 310.

NEW YORK, JANUARY 11, 1889.

SINGLE COPIES, TEN CENTS.
\$3.50 PER YEAR, IN ADVANCE.

THE

American Bell Telephone
COMPANY.

95 MILK ST., BOSTON, MASS.

This Company owns the Letters Patent granted to Alexander Graham Bell, March 7th, 1876, No. 174,465, and January 30, 1877, No. 186,787.

The Transmission of Speech by all known forms of **ELECTRIC SPEAKING TELEPHONES** infringes the right secured to this Company by the above patents, and renders each individual user of telephones, not furnished by it or its licensees, responsible for such unlawful use, and all the consequences thereof and liable to suit therefor.

SCIENTIFIC BOOKS.

Catalogue of Books relating to Civil, Mechanical, Electrical, and Mine Engineering, and Manufacturing Industries sent free to any address.

E. & F. N. SPON,

12 Cortlandt Street, New York.

ELECTRICAL TESTING BUREAU,

Johns Hopkins University, Baltimore, Md.
Resistance Coils and Boxes Compared.
Am meters and Volt meters calibrated.
Condensers standardized.
Primary and Secondary Batteries Tested.
Efficiency of Dynamos and Motors Determined.
Insulation of Cables and Wires Tested.
Etc., Etc.
Circulars describing Methods Used, Prices, Etc., sent on Application.
Address as above.

R. ELLIS & CO.

BUSINESS, HOTEL AND PATENT BROKERS,

AUCTIONEERS, ETC.

No. 176 BROADWAY,

Room 46.

New York.

CLIENTS Advised free of charge.

Encyclopaedia Britannica.

POPULAR REPRINT. SOLD BY SUBSCRIPTION ONLY.

We are publishing a popular reprint of the Encyclopaedia Britannica at \$2.50 per volume, bound in cloth of the best quality. This is less than one-third the price of the original English edition, in the same binding, published by A. & C. Black, of Edinburgh, which edition we are reproducing, page for page, plate for plate, map for map, and volume for volume.

The same word begins and ends on any given page, as it does on any given page of the original edition. The same number of volumes (24) completes our set, as will the original, and at about half the price of the other 2 subscription editions, both of which are printed from the same original English edition, from which we also reprint.

No such book has ever been put upon the market, of such size and quality of binding (the latter as good as that of any other edition of the Britannica), for so low a price. It is a well-known fact that it contains the highest character of knowledge and literature in the world: written by the most eminent living authors, the articles signed by 7,500 eminent specialists will form in the aggregate over five-sixths of the contents of the work. In fact, it is the greatest work of its kind that has ever been published in the English language.

We are reproducing the latest volumes issued of the (ninth) original ENGLISH edition which has just issued its 24th and completing volume.

In offering the Encyclopaedia at this unprecedented low price, the publishers have reason to believe the opportunity will not be lost by the purchasing public.

The Encyclopaedia Britannica is a library in itself and the knowledge of centuries focused: the essence of all books crystallized.

One of our chief desires is to obtain as subscribers all those who have ever entertained an idea of owning the Encyclopaedia Britannica, but hesitated on account of the high price.

Truly the "Best is Now the Cheapest."

SMITHSONIAN INSTITUTION
THE SMITHSONIAN INSTITUTION COMPANY,
125 N. 3rd St. Wash. D.C.
& 74 1/2 Broadway.

THE SECRET DOCTRINE.

The Synthesis of Science, Religion and Philosophy.

BY H. P. BLAVATSKY,

Author of "ISIS UNVEILED," and founder of the Theosophical Society.

2 Vols. Royal Octavo. Cloth \$10.00.

AN UNPRECEDENTED LITERARY EVENT.

This book is written with the especial aim: "to show that Nature is not a 'fortuitous concourse of atoms,' and to assign to man his rightful place in the scheme of the Universe. . . . to show that the occult side of nature has never been approached by the science of civilization." It is based upon stanzas from the **BOOK OF DZYAN**, an archaic MSS. unknown to the Western world, with erudite commentaries, explanations and elaborations. In the Addenda Modern Science is contrasted with Esoteric Science.

The Darwinian theory of Evolution is shown to be wrong, and it is asserted by the author that the Apes are not our ancestors but are degenerate descendants of prehistoric man.

*The book also attempts to show that all the forms upon the earth have been produced by man who has passed through each one in his evolution.

The Moon is held to be the progenitor of the Earth and not a mass that was thrown off by the latter in cooling.

The author shows enormous erudition, and if readers call the book an invention they must place the writer at the head of the geniuses of the age.

CHARLES T. DILLINGHAM, 718-720 Broadway, New York.

GUARANTY INVESTMENT COMPANY

CAPITAL \$250,000.

Hon. ALBERT H. HORTON (Chief Justice, Kansas Supreme Court), Topeka, Kan., Pres't.

7% Guaranteed Farm Mortgages 7%

The Company calls the special attention of Investors to the following points :

- I. All loans guaranteed and interest payable semi-annually at the Importers' & Traders' National Bank, New York.
- II. Unusual fulness of information, not only about the security itself, but about the general development of the section where the farm is located.
- III. An examination each year of the general business of the Company and the Mortgages themselves by a COMMITTEE OF INVESTORS sent for the purpose.
- IV. Many hundred Mortgages taken and NOT A SINGLE FORECLOSURE.
- V. Exhibitions in New York at frequent intervals, of Kansas and Nebraska Farm Products. The Exhibition at the American Institute in the fall of 1888, received the *HIGHEST AWARD* of superiority.
- VI. Monthly Bulletins giving full information about all Mortgages offered for sale.

Address for Monthly Bulletin and Investors' Committee Report for 1888,

HENRY A. RILEY, General Eastern Manager, 191 Broadway, N.Y.

THE NUN OF KENMARE.

An Autobiography, by MARY FRANCIS CLARE CUSACK, late Mother General of the Sisters of Peace. 12mo. 580 pages. With fine portrait. \$1.50.

"Revelation of the Roman Church from the Inside—The Autobiography of Mary Francis Cusack—Conventual Life Unmasked—The Catholic Hierarchy with the Light Thrown on it—A Woman Tells What She Knows."—Boston Herald.

"The Nun of Kenmare,—a book which will prove a bombshell.—Her reasons for giving up her life-long work.—Jealousy of priests and prelates.—Early Life.—Literary labors."—*British American Citizen*.

"The pathetic story will be read with close attention by those for whom the author has labored so long and so devotedly, and by those of all creeds, sects, and nations who yet believe in Christian charity, and would not see any good work crushed and hampered by jealousy and opposition."—*Cambridge Tribune*.

"The greatest interest has been manifested in this work. The Ticknor house has been besieged by people eager to secure the earliest possible copy, or even any clue to the nature of the contents."—*Chicago Inter-Ocean*.

Sold everywhere. Sent, postpaid, on receipt of price, by the publishers.

TICKNOR & CO., Boston.

Paillard's MUSIC BOXES ARE THE BEST.

They play the best selections from all the
*Standard and Light Operas, Dances,
Waltzes, Ballads, Hymns, etc.*

Arranged in sets to suit every variety of taste. The largest and most varied stock ever shown in this country. A rare musical treat to all who can visit our warehouses.

M. J. PAILLARD & CO.,
680 Broadway, New York.
Factory, St. Croix, Switzerland.

KNABE PIANOFORTES. UNEQUALLED IN

Tone, Touch, Workmanship and Durability.

WILLIAM KNABE & CO.
NEW YORK: No. 112 Fifth Av., above 16th St.
BALTIMORE: Nos. 22 and 24 E. Baltimore St.
WASHINGTON: No. 817 Market Space, Penn. Av., near 9th St.

Whitall's Pianispheres locate and name all the Planets, Stars, and Constellations visible at any given minute of time. Every person should possess a set, and obtain useful and interesting knowledge. Heliotellus, Geographical Astronomical Instruments for Schools, private, public, and kindergarten. Ask your Bookseller and Stationer, or address Wm. T. Cooper, manager, 307 Race St., Philadelphia, Pa.



KIMBALL'S STRAIGHT CUT CIGARETTES.

Unsurpassed in quality.
Used by people of refined taste.
Highest award at Brussels, 1888.
The finest smoking mixtures are of our manufacture.
Fifteen First Prize Medals.
WM. S. KIMBALL & CO.,
Rochester, N.Y.

What Scott's Emulsion Has Done!

Over 25 Pounds Gain in Ten Weeks.
Experience of a Prominent Citizen.

THE CALIFORNIA SOCIETY FOR THE
SUPPRESSION OF VICE,
SAN FRANCISCO, July 7th, 1886.

I took a severe cold upon my chest and lungs and did not give it proper attention; it developed into bronchitis, and in the fall of the same year I was threatened with consumption. Physicians ordered me to a more congenial climate, and I came to San Francisco. Soon after my arrival I commenced taking Scott's Emulsion of Cod Liver Oil with Hypophosphites regularly three times a day. In ten weeks my avoirdupois went from 155 to 180 pounds and over; the cough meantime ceased. C. R. BENNETT.

SOLD BY ALL DRUGGISTS.

SCIENCE

FRIDAY, JANUARY 11, 1889.

THE CONTINENTAL DYNAMO.

MANY of the most important improvements that have been made in the last few years in dynamo-construction have been in the direction of greater simplicity and solidity of design, me-

chanically and electrically, and in the better proportioning of the different parts. No radical changes or discoveries have been made; but, if we compare the dynamo of to-day with that of four or five years ago, we will find a greater efficiency, a much greater

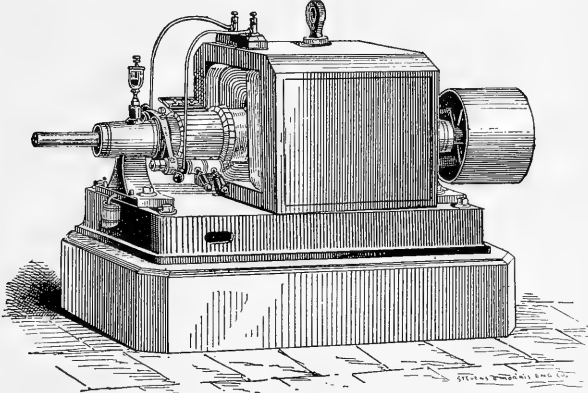

THE CONTINENTAL DYNAMO.

chanically and electrically, and in the better proportioning of the different parts. No radical changes or discoveries have been made; but, if we compare the dynamo of to-day with that of four or five years ago, we will find a greater efficiency, a much greater

if it becomes necessary, they may be removed by simply taking off one bearing. There being very little leakage of lines of force, — only a few per cent compared with twenty to forty per cent for an ordinary dynamo, — there is no ill effect on watches brought in its

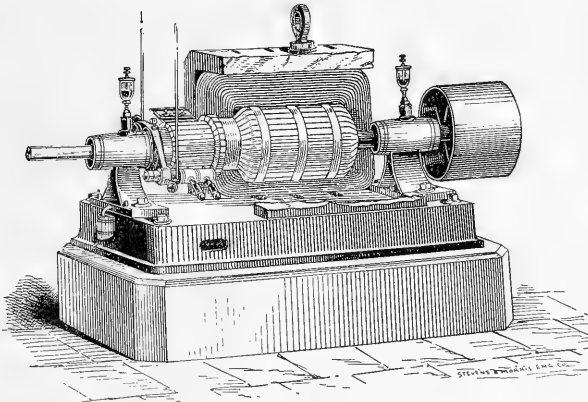

INTERIOR OF CONTINENTAL DYNAMO.

output of current for the same weight of metal in the machine, and less expense for repair. But while no radical changes in principle have been made, yet some new types of dynamo have been introduced that present important peculiarities. The Continental dynamo, which we illustrate in this issue, seems to be as simple and compact as it is possible to make a dynamo. The pole-pieces and

neighborhood. The advantages of the dynamo seem to be in simplicity and solidity of construction, accessibility of different parts, no leakage of lines of force, and efficiency, while little care is necessary in attendance; and, as it is not high-priced, it is a machine that in general is likely to meet the demands of a wide circle of users.

BALL ELECTRIC-LIGHTING SYSTEM.

ONE of the most peculiar of the many dynamos that have been used or proposed for arc-lighting is that of the Ball Electric Company. From the accompanying illustration it will be seen that two armatures are mounted on the shaft, with one pole-piece for each.

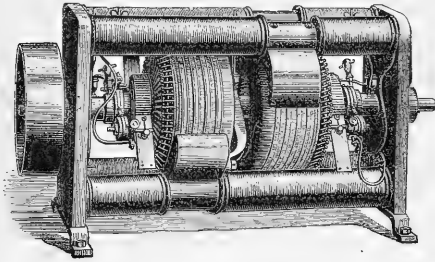

THE BALL DYNAMO.

The armatures are of the well-known Gramme ring type, and are constructed with a large number of separate coils, thus reducing the sparking at the commutators to a minimum. By some it is claimed that the dynamo must be at a disadvantage from the considerable magnetic resistance that the lines of force experience in passing from pole-piece to pole-piece. By others it is said that this is not so, as the lines of force do not close their circuit from pole to pole, but from poles through armatures to magnet-bars opposite; and that from the thinness of the copper windings, and from there being two armature-cores in multiple across a common field, the magnetic resistance is actually less than in other makes

The mechanical construction of the dynamo is excellent, and, from the testimonials contained in the last circular issued by the company, it would seem that the machine can stand the maximum of rough usage with a minimum of repair.

Besides the high-power lamps of 2,000, 1,600, or 1,200 candle-power, the Ball Company advertise smaller arc-lamps of 800 candle-power, for use in stores, etc., and they also provide incandescent lamps to be used on arc-light circuits. They also furnish complete incandescent-light installations.

THE "IDEAL" STEAM-ENGINE.

AN improvement in one of the most important steps in the conversion of heat into power, showing the results of scientific methods applied to the design and construction of the steam-engine, is illustrated on this and the next page. This engine, which is known as the "Ideal," is a more highly developed form of the Ide engine, and is manufactured by A. L. Ide & Son of Springfield, Ill. It was designed to meet the special requirements of electric lighting, such as high speed, small space, perfect regulation, absence of vibration, and economy in the use of steam; and the results shown by actual use prove that the designers of the engine are progressing in the right direction. The engine is compact, perfectly balanced, and self-oiling; and, as it has a rigid double frame with heavy sub-base, it may be run at a high speed without vibration.

The manner of lubricating the guides, cross-head pin, and piston-rod, is shown in the longitudinal section, Fig. 1. The oil is taken up by the crank-pin disks, when in motion, and thrown by centrifugal force upon the guides and piston-rod. The oil wiped from the upper guide by the cross-head slide passes through a tube in the top slide, entering a funnel in the connecting-rod, and thoroughly lubricating the cross-head pin. The peculiar manner of keeping a constant supply of oil in contact with the crank-pin, main bearings, and eccentric, is shown at Fig. 2. Some of the oil thrown off by the revolving disks is caught in the pockets in the disk-hood (Fig. 1). The oil from the upper pocket is conducted by a tube provided with a regulating-cock to a receptacle on the eccentric-strap, whence it passes, after lubricating the eccentric, to a drip-pan underneath, and thence back to the oil-well for further

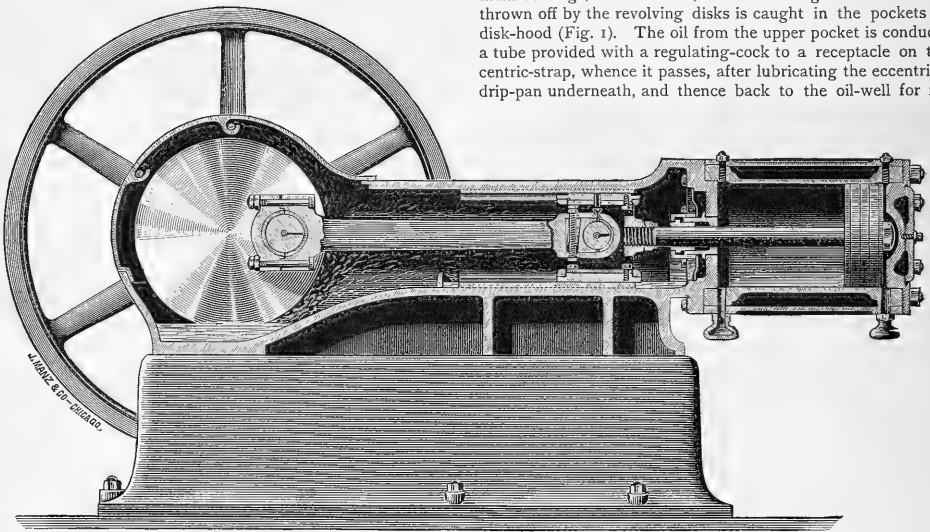

FIG. 1.

of dynamos. The large output of the dynamo in comparison to its weight, and the small amount of copper used upon its field, seem to testify to the correctness of the latter.

Its advantages, which are of a practical kind, lie in the fact that by distributing the rotating wire on two armatures the number of layers can be reduced, the difference of potential between adjacent turns is less, and therefore there is less liability to burn out, while the excellent ventilation prevents overheating; also, if any thing happens to one armature, the other can be used to run part of the lamps.

use. The oil from the other pocket flows through pipes into pockets cast upon the main bearings. From these points it flows into the grooves and channels connecting with the crank-pin, which is hollow. The centrifugal force carries it into the crank-pin, from which it escapes through holes into the bearing. Thus it will be seen that the main bearings receive constant lubrication, while the crank-pin receives a supply of oil from either side. This method of lubrication is constant, and provides for the most important bearings about the engine. Sufficient oil is placed in the basin under the crank-disks to cause it to flow in streams through both

pipes and in drops to the eccentric, but valves are provided on the pipes so that the supply can be regulated as desired; and the reservoir can be supplied with fresh oil while the engine is running. Besides the saving in oil, these devices keep a clean and presentable engine and engine-room.

The automatic cut-off governor is shown in Fig. 3. It is an isochronous governor, very simple in construction, and responds instantaneously to the slightest variation in load, cutting off the steam at a point that will just do the work and maintain the fixed speed of the engine. It is secured to the side of the fly-wheel, and connects direct through the eccentric on the main shaft with the valve, without the use of gearing, pulleys, shafts, or belts. All its parts are in sight, and are readily accessible for cleaning. It gives an open port at the beginning of each stroke, admitting steam to the piston at full boiler pressure, and varies the point of cut-off as the load requires, from the beginning to three-fourths of each stroke. The speed of the engine remains practically constant, regardless of the change of load or variation of steam-pressure in the boiler, the variation from no load to the full power of the engine being, it is claimed, less than one per cent. The

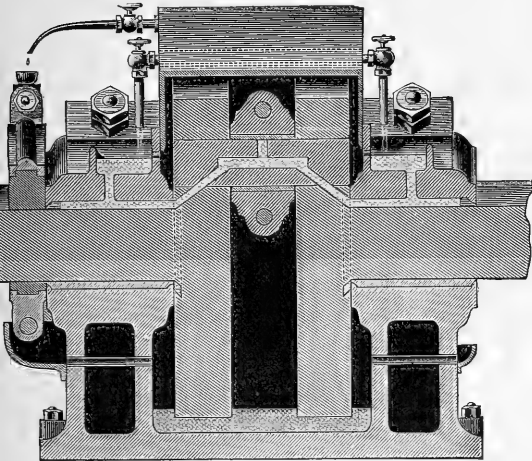

FIG. 2.

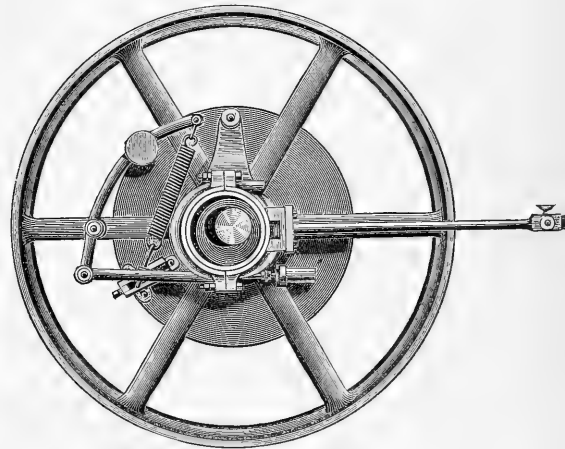

FIG. 3.

dash-pot attached to the eccentric prevents any sudden movement of the weight when a great change of load occurs suddenly. The running speed of the engine may be changed to suit requirements by shifting the position of the lever.

The steam-chest is bored out and fitted with a pair of cylinders or bushings which have supporting bars across the ports, to prevent any possibility of the valve catching upon the ports. The valve is of the hollow piston type,—a hollow tube, with a piston at each end. It is surrounded by steam, which presses equally upon each end, thus perfectly balancing the valve and relieving its pressure, insuring it long service with little wear. The piston-head is a single casting, hollow, and as light as is consistent with strength. The cross-head is a crucible steel casting, with phosphor-bronze slides; and the attachment to the connecting-rod is central, thus avoiding any strain on the piston-rod by angular thrust. The guides are bored out the same size as the cylinder, thus insuring large wearing surfaces and constant accuracy of line with cylinder. This, together with the self-oiling devices, insures cool running, and long service without adjustment. It may be added, that the construction seems to be such as to give the required strength and rigidity for high speeds; ample wearing surfaces are provided; all the parts are made of steel, phosphor-bronze, and charcoal iron, and are interchangeable; and every engine is tested by actual service at the factory.

SCIENTIFIC NEWS IN WASHINGTON.

Does Exposure to the Sun cause the Human Skull to be Harder and Thicker? — Diseases of Menagerie Animals.— The Geological Survey.

Does Exposure to the Sun cause the Human Skull to be Harder and Thicker?

ONE of the most interesting things mentioned by Professor Virchow in his little book just published, entitled "Medical Remembrances of an Egyptian Journey," in which he describes an excursion up the Nile as far as the first cataract, is that the broken skulls on the first great sepulchral fields, dating from Roman times, are as thick and hard as Herodotus says those of the slain Egyptians were in comparison with the brittle ones of the Persians. The Greek historian explains this by attributing it to the early exposure of children to the heat of the sun; and in many parts of upper Egypt the German travellers actually found young children thus exposed during their parents' absence in the fields, in immense clay bowls, resembling in shape a champagne-glass with a stem, into which they were put without shelter.

This discovery by Professor Virchow is interesting, because it at once suggests the question whether the proverbial thickness of the skull of the negro has not been caused by exposure to the sun, and whether it is a peculiarity of savages of tropical countries that their skulls are thicker and harder than those of the inhabitants of temperate and colder countries.

Students of craniology have never made any investigation to ascertain whether the skulls of different races vary in degrees of hardness. It would be almost impossible to make such an inquiry. As is well known, the human skull increases in hardness from childhood to maturity and age. A miscellaneous collection of skulls of any given people would therefore be of no value in such an investigation. To obtain a collection of skulls of a number of nationalities, that should be taken from subjects all of the same age, to have them all similarly prepared and in sufficient numbers to make it possible to draw any general conclusions from their comparison with each other, would be manifestly impossible.

More attention has been given to the relative thickness of different skulls, or rather to their weight, from which their thickness may be inferred. Of the large collection of crania in the Army Medical Museum at Washington, the thickest are those of negroes and Alaskan Indians. The skulls of other Indians, both of North and South America, in tropical or temperate climes, and of the Eskimo, do not appear to be particularly thick. Among the ancient

Peruvian skulls recently received by the museum, and the ancient crania collected in Arizona last summer, there are frequent individual variations in thickness, but no tendency to unusual thickness. The conclusion from these facts is, that exposure to the sun probably does not cause thickness of the human skull.

In connection with this subject, it is interesting to note, that, among the Australians the *sinus frontalis* is generally found to be solid in the males, instead of being hollow as in the skulls of other races. This bone in the male Australians generally extends straight across the head, the lower side overhanging the eyes so that they seem to look out from under it, while in the North American Indians a modification of shape deprives them of that heavy look about the forehead. The heavy *sinus frontalis* of the Australians, of course, increases the weight of the skull.

Diseases of Menagerie Animals.

At the meeting of the Biological Society, Mr. F. A. Lucas read a paper on "The Diseases of Menagerie Animals." He showed that menagerie animals are extremely liable to disease; and this is almost as true of those born in captivity as of those which are captured when full grown.

Young animals suffer greatly from caries, owing to lack of proper diet, and their bones are very generally soft, swollen, and misshapen. The maxillaries are especially liable to be attacked during the period of teething, and the facial region is in consequence very much distorted.

Diseases of the lungs are very prevalent among menagerie animals, tuberculosis being exceedingly common among monkeys, and found among other animals less frequently. Pneumonia is a frequent cause of death, and birds as well as mammals are liable to be attacked by this disease.

The following is a list of animals examined, where the cause of death was fairly established:—

- Macaque (*Macacus cynomolgus*).—Tuberculosis.
- Gray fox (*Urocyon virginianus*).—Pneumonia. This specimen also exhibited a very bad case of intestinal catarrh and inflammation of the bladder.
- Badger (*Taxidea americana*).—Pneumonia.
- Elephant (*Elephas africanus*).—Pneumonia.
- Lynx (*Lynx rufus*).—Uræmic poisoning (in two cases).
- Black bear (*Ursus americanus*).—Killed. Had been sick for some time with catarrh of stomach and intestine.
- Minot bird (*Eulabes affinis*).—Congestion of lungs.
- Parrot (*Amazona ochroptera*).—Congestion of brain (?) This bird died suddenly, and all organs were healthy. The blood-vessels of the brain were much congested.
- Parrot (*Amazona Levaillantii*).—Tuberculosis.
- Tooth-billed pigeon (*Didunculus strigorostris*).—Disease of liver, that organ being converted into a hard, waxy mass adherent to sternum.
- Pigeon (*Columba livia domestica*).—Disease of liver, same as above.
- Eagle (*Haliaeetus leucocephalus*).—Fatty degeneration of liver.
- Night heron (*Nyctherodius violacens*).—Congestion of lungs.

The Geological Survey.

Appropriate committees of the Senate and House are considering, with very favorable tendencies, the bill appropriating \$600,000 for the erection of a building for the Geological Survey, on the public reservation near the Smithsonian, where grounds have been allotted to it. The plan submitted by Major Powell contemplates a solid and compact rectangular structure, covering 100 by 300 feet, five stories high, with hipped roof. It will be of Seneca sandstone (like the Smithsonian), or of selected red brick with sandstone buttresses, trimmings, and belt courses, and overground basement of same. The general arrangement will consist of a series of large, well-lighted rooms, averaging 16 by 24 feet, disposed about a spacious central court lighted from the top, and with tessellated floor. In this court the working collections of the survey will be open to inspection. The preliminary ground plans and elevations have been prepared by Messrs. Victor Mindeleff and Delancey W. Gill of the Geological Survey.

THE TASK OF STATE WEATHER SERVICES.

PROFESSOR FRANCIS E. NIPHER, in an interesting pamphlet on the rainfall of Missouri, takes occasion to urge the establishment of State weather services. "The State weather service," he says, "bears the same relation to the national service that the State Government bears to the National Government.

"There are many large storms, of great severity, which damage shipping and endanger life. The Signal Service has done a great work in giving warning of these storms. Shippers and dealers in provisions and fruits find the cold-warm warnings of the greatest value. In all large cities the approach of a 'warm spell' is known through the Signal Service predictions, and thousands of tons of meats are hurried to cold storage warehouses, and the opportunity to ship other provisions which must be kept from freezing is anticipated and made available. It is not saying too much to say that it would be impossible to carry on the shipping business of the country as it is now carried on, without the aid of the national weather service.

"But each State has its own peculiar industries, advantages, and interests. It should provide for a thorough study of its own climate, and should distribute published reports for the benefit of those who may desire such knowledge.

"There is another field which peculiarly belongs to the State weather service. The weather which is of greatest importance to the farmer is the weather of harvest. During that time storms are usually very local. They may cover a few counties only, and inflict immense damage. People living in the city can learn from the Signal Service that there will be 'local rains in Missouri,' but nobody knows where in Missouri they are going to locate; and even this information reaches the farmer only after the rain is over, if at all.

"The local peculiarities of these storms require study in each State. Very much has been done in this direction in Iowa and by the New England Meteorological Society. Such work should be at once begun in our State. In three or four years we should be familiar with the behavior of these storms, and this knowledge could be given to all.

"In 1893 the telephone will become public property, and it will then be possible for county telephone services to be established, putting each farm in communication with a county seat. Telephone service can be rendered for a sum which will be utterly insignificant when compared with the advantages which it will bring. Farmers can then keep informed of the markets, can sell their produce before leaving their homes, and will be able to save much time which they now waste during the busy season of harvest. This is all so apparent that it is needless to discuss it further. In addition, there will grow up a system of harvest storm warnings. It will be very easy for any county telephone system to give its subscribers a general warning of an approaching thunder-storm, and to transmit that information to such other counties as may be in danger. The exact details of this scheme may be left to the director of a State weather service to work out. It seems certain that this can and will be done, and there is no reason that this should be done by the national weather service."

COMMERCIAL GEOGRAPHY.

The Development of Commerce on the Kongo.

The Belgian Compagnie du Congo pour le Commerce et l'Industrie is pushing on its enterprises vigorously. The most important among these for the development of the resources of Central Africa is the railroad from Matadi to Stanley Pool, connecting the navigable upper Kongo with the highest point that can be reached by steamers. In the past year a corps of engineers was engaged in surveying this line, which offers peculiar difficulties on account of the deep gullies cutting the line to be followed by the road at right angles. At a recent meeting of the shareholders of the company, M. Cambier, chief engineer of the expedition, gave a report of his proceedings, which has been published in a recent number of the *Mouvement Géographique* from which we take the following statements and the accompanying map.

It will be noticed, that while the old caravan route runs approxi-

mately parallel to the Kongo, and crosses its affluents near their mouths, the railroad either crosses these rivers near their sources or keeps on the divides between these river systems. Thus the deep gullies and valleys are avoided, gentle slopes prevailing on the plateau. Considerable difficulty was encountered in climbing this highland which falls abruptly to the river. It was found impossible to ascend it by one of the tributaries of the Kongo coming from the south, as they run in inaccessible gorges. But fortunately a depression was found a short distance below Matadi, from which point the projected road ascends the highland. The road will cross the tributary Mpozo on a bridge, and, after having avoided the plateau of Palababa by a *détour* to the south, it takes an east-

about 300 feet above the Kongo, which are traversed through narrow and tortuous valleys. Later surveys show that a better line may be found farther to the west. Although it will be some time before work on this line is taken up, the results of these surveys show that it may be constructed without incurring extraordinary expense. Preliminarily the establishment of a regular connection with the upper Kongo by means of oxen is contemplated.

The commercial reconnaissance of the upper Kongo region, and the tentative establishment of stations by the Belgian Company as well as by the Sandford Exploring Expedition, have encouraged the promoters of these enterprises to take more energetic action. The two companies have recently joined, and formed the Compagnie

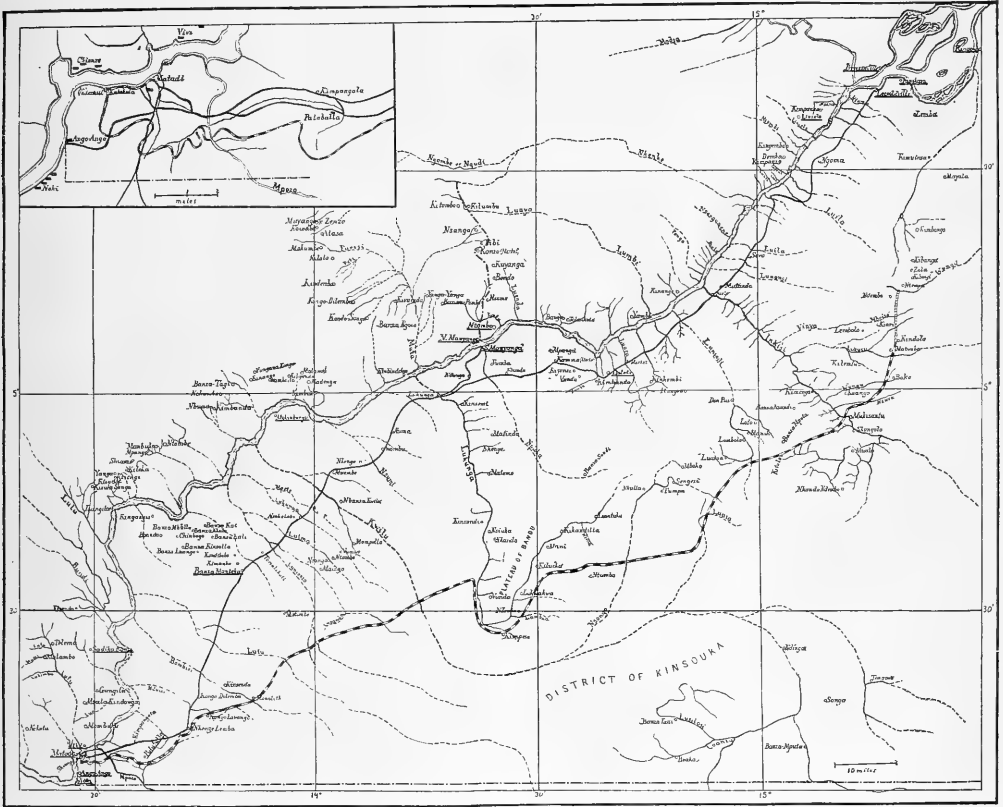

PROJECTED RAILROAD FROM MATADI TO STANLEY POOL, KONGO FREE STATE.

north-easterly direction, until the river Lukunga is met. It seemed at first that some difficulties would be encountered here; but the reconnaissances of the engineers showed that the valley of the river takes a north-easterly turn, and thus they were enabled to follow its left bank without crossing it. No serious obstacles are encountered between the bend of the Lukunga and the Inkissi, the country consisting of hills intersected by small ravines. Between the line and the Kongo rises the plateau of Ngombi to an altitude of 1,600 feet. This part of the country is intersected by deep valleys. The Inkissi, at the point where the railroad is proposed to cross it, is about 350 feet in width. A number of rocks are found in its bed, which will facilitate the construction of a bridge.

East of the Inkissi the population becomes less numerous, and the country is more elevated and sandy. The heights of the hills are clad in forests, and deep ravines intersect the slopes of the plateaus. Approaching Stanley Pool, the line has to pass over hills

Belge du Commerce au Congo, with a capital of 1,200,000 francs, which has for its purpose the establishment of regular commerce with the Kongo basin.

HEALTH MATTERS.

The Schoolroom as a Factor in Disease.

A VERY valuable paper on "The Schoolroom as a Factor in the Production of Disease" was read by Dr. J. A. Larrabee of Louisville, Ky., at the last meeting of the American Medical Association, and is reported in full in the *Journal*. Estimating that one-third the lifetime of every educated person is passed in the schoolroom, it follows that the location, construction, and surroundings of the same are matters of importance. While there has been great advance in these respects, much still remains to be done. In Switzerland the summits of small hills are selected as school-sites.

Schoolhouses should be built in parks, and every thing possible done to make them attractive both outside and within. Ventilation is a matter of prime importance. Among the diseases caused or favored by schools, he places the following: contagious diseases, headaches, eye affections, chorea, and consumption.

This paper was discussed by several of the members of the association. Dr. Lindsley of Tennessee said that there were two points which he wished to emphasize: 1. Medical men must arouse public attention to the necessity for paid medical inspectors. 2. No text-books of hygiene should be put in the schools, because the masses do not get this education. The majority of children leave the schools before reaching the higher classes where this subject is taught. Hygiene should be impressed upon them by every feature of their environment.

Dr. Hibberd of Indiana agreed with Dr. Lindsley in the utter impossibility of teaching children in primary schools enough physiology to be of utility. There are many who are grandfathers who do not know what it is absolutely necessary to teach. Teach youth to observe, and what things they should observe. The trustees of schools understand the necessity for air, light, etc., but they cannot get the money to provide them. Every schoolhouse in the land should be situated so as to face the best direction of the compass, having air and light in abundance; but it will cost a great deal of money.

We must recognize that all children are not exactly alike in their capacity for receiving education; and the present methods are faulty in teaching all children on the same plan. Due regard must be paid to mental and physical variations, and sound minds and bodies cannot be had until this is recognized.

Dr. Hamilton, United States Marine Hospital Service, said that the reason that the majority of German children were myopic was due to the employment of the old black letter. German medical text-books are printed in Roman letters, but for political reasons the black letters are generally used. He believed in the necessity for school-inspectors; and the first thing they should do would be to examine the text-books, the paper of which is often inferior, and the printing but little better. Another feature demanding improvement is the sitting arrangement of a schoolroom. All know the country schoolroom, with its four rows of desks, and windows on either side of the room, which imperfectly light the middle rows of desks.

Dr. Vaughan of Michigan did not believe that all defects in eyesight in school-children are attributable to the schoolroom. If one enters any family room at night, the father and mother will be found sitting on either side of a table on which the light is, and the children are allowed to sit anywhere. More harm is done young girls by sitting up late at night at parties and dances than by all the alleged confinement in the schoolroom. Dr. Larrabee did not refer to the stairs, which are usually selected as one of the fertile sources of disease in young girls; but if one watches a woman go upstairs, she does it with her body bent forward, and swinging from side to side, instead of going upstairs erect. The German method of the climbing cure might be employed advantageously in some of these cases. In Michigan most children are better situated at the schoolhouse than at home; farmhouses, as a rule, from a sanitary point of view, being far from good. The ignorance of teachers on hygienic matters seems to me to be the primary evil.

Dr. Hibberd believed, with Dr. Vaughan, that the fundamental education should be with the teacher. But the architect must also be remembered. This gentleman usually puts his efforts on the adornment of the exterior of the building, and the interior is suited to this. One cannot get architects to give sufficient attention to the interior of these buildings, because it is their aim to produce handsome work.

Dr. Vaughan stated that the plans for school-buildings in Michigan must be approved by the State Board of Health.

ELECTRIC LIGHT AND EYES.—In the *Medical News*, Dr. George M. Gould discusses the question, "Is the electric light injurious to the eyes?" Before proceeding to the direct answer of this question, he refers to the relation of the electric light to general hygiene. Most every one, he says, has a general impression that the electric light is much superior to other methods of artificial illumination, so far as concerns our general health and comfort, but

few could give a reason for the faith that is in them. They will come out of a theatre, music-hall, church, etc., with headaches, lassitude, exhaustion, their bodies bathed in sweat, all resulting in colds and a multitude of major and minor affections, and never utter a word of protest or complaint against the culpable and parsimonious management that permits the vitiation, poisoning, and superheating of the atmosphere by a thousand gas-jets. In the discussion of the question as to the injury to the eyes by the use of the electric light, Dr. Gould refers at length to the literature of the subject, and sums up the whole matter in the following conclusions: 1. As regards general hygiene, the superiority of the electric light over gas as an artificial illuminant is so overwhelming as to admit of no discussion. It is incontestably the light of the future, and the public should not rest until its meeting-places, such as theatres, halls, reading-rooms, churches, etc., are lighted by the most perfect system at its command. 2. A study of the published cases of injury to the eyes by the electric light shows that not one was due to the use of the diffused light as an illuminant. The popular prejudice against such a use of it is absolutely without justification. All the cases reported were of scientific investigators, etc., or workmen about the light, who approached it very closely, gazed at it protractedly, and without protecting colored spectacles. 3. The ocular injury is due, not to the supposed preponderance in the electric-light rays of violet and ultra-violet (chemical or actinic) waves, but simply to the greater number (intensity) of the usual length light-waves. 4. The symptoms of the ocular injury are possibly immediate temporary "retinal paralysis," blepharospasm, central scotomata, chromatopsia, after-images, etc. Within twenty-four hours there come on intense photophobia, lachrymation, ocular pain, a feeling as of foreign bodies beneath the lids, conjunctival hyperemia and congestion, pericorneal circles, etc. 5. The attack usually lasts but two or three days; the prognosis is excellent; the treatment is simply cocaine and atropine instillations and cold or hot compresses. 6. Workmen and experimenters who must approach closely to the electric light should protect their eyes by smoked or tinted glasses, the depth of the tint being greater where the light is more brilliant, the proximity greater, or the exposure longer. In the welding-works the workmen must be particularly careful about this, and must also not expose the skin of the face, neck, and hands to the action of the light. The precaution may not be amiss to advise the curious against testing their eyes by gazing at the ordinary arc and glow lights at short range.

ELECTRICAL NEWS.

The Electric Sugar-Refining Process.

IN the last week the daily press, and the stockholders of the company organized to develop the electrical refining of sugar, have learned that the process does not exist, and that a gigantic fraud has been perpetrated. It is just to remark that many of the electro-technical papers have denounced the scheme from the first. "With the Keely motor, it demonstrates the fact, that, by making large enough promises, a clever adventurer can get a great many people to advance money to promote the most impossible plans. There are few people who will not risk a few hundreds, or even thousands, on the promise of making a million in a short time. The refining process in question was secret from the first. Elaborate precautions were taken to avoid publicity, — a fact that should have at once aroused the suspicion of investors. A large sum of money (\$250,000 to \$350,000) was given the alleged inventor for the purpose of equipping a factory; and a few bags of raw sugar, taken to the works and submitted to the process, apparently came out as refined sugar. In reality this was effected in an extremely simple manner, by substituting previously provided refined sugar for the raw in the secret "electrical" chambers. The whole matter illustrates forcibly what we recently said about electrical investments, that while there are such investments which will give better returns than in almost any other industry, yet, like any thing else that is new and not well understood, it has been and still is the means by which a great deal of money has been obtained from trusting investors, from which there will never be any return.

THE ELECTRIC LIGHT IN LAND WARFARE.—The London *Electrician* describes the following experiments made on Hamp-

stead Heath, for the purpose of testing the capacity of small electric hand-lamps in searching for the wounded men left after a battle, and thus more rapidly than hitherto bringing the sufferers within the reach of surgical aid. The experiments were made by the officers and men of the London Division of the Volunteer Medical Staff Corps, — an organization which already consists of four efficient companies, largely composed of medical students, and for which a fifth company is now in process of formation. The corps, under Surgeon-Commander Norton, accompanied by ambulance-wagons, and provided with stretchers, halted upon one of the Heath roads at a time when the thick mists still hung heavily upon the lower grounds, and having established a field-hospital in a rather dreary-looking spot, poorly sheltered by bare trees, sent out its searching stretcher parties to pick up the bandsmen who had been distributed over the open ground at some distance off, to simulate the wounded left from a fight during the daylight. By the aid of the lamps thus brought into use for the first time, the men sought were found with comparative rapidity, the lights being sufficient also to enable the trained ambulance-men to apply preliminary bandaging upon the spot, and before loading the stretchers, which by other lights at the wagons were guided back to the road. There the men were carefully placed in the vehicles, and conveyed to the field-hospital, where the examining surgeons found very little to correct in the treatment adopted under such disadvantageous circumstances. The results achieved indicate sufficiently well, says the *Daily News*, that the electric light thus used would be of immense value, and tend greatly to reduce the suffering of men left upon the field at the close of a fight.

AN ELECTRIC ROAD FOR CHATTANOOGA. — There has been a very rapid extension of electric street-railroads during the year in all but the Southern States. Here only one very important road has been completed, although several are under contract. The street-car system of Richmond has been equipped with electric motors, and recently the Thomson-Houston Company has opened a short road in Danville. The most important contract in the Southern States since the Richmond road was finished is that recently given by the Chattanooga Street Railway Company to the Sprague Motor Company. The line will be five miles long, and there are on it a number of sharp curves and heavy grades, the maximum being about eight per cent. The road will be newly constructed throughout. Eventually the entire railroad system of Chattanooga will be equipped with electric cars. The present road will have overhead conductors, a small wire fed from a larger wire, — the former over the track, the latter anywhere that is most convenient. The motor-cars will be of the new Sprague type, lately described in this journal.

THE EDISON LAMP PATENTS IN ENGLAND. — There will soon be given a very important decision on Edison's patents for incandescent electric lamps. In this country there has been no direct decision as to the validity of Edison's patents, all of the suits heretofore having been of a preliminary character; but in England and Germany several suits for infringement have been brought by the companies controlling Edison's patents in those countries, and the decisions, with one exception, have been in their favor. It is an appeal from this adverse decision that has just been argued. In the case, Edison's patent was declared invalid mainly because of incomplete specification, Justice Kay holding that a lamp as made by Edison's description was not commercially successful, nor could it be made so. Witnesses on the two sides attempted to make lamps according to the specifications; and those called by the Edison Company succeeded in doing so, while those on the other side uniformly failed. Finally Professor Stokes was appointed as referee, and a number of lamps were made and were tested. Some of these gave out in a few hours, others burned longer. The results obtained would not be in any way satisfactory as compared with our present lamps, nor could a station using these first lamps be run at a cost to make such an enterprise practicable. Professor Stokes reported impartially the result of the experiments, which at the time were generally considered as favoring the Edison patents. Justice Kay decided, however, that the lamps described in the specification never became, nor could ever become, a commercial success. The case on appeal is now before the same court that formerly affirmed

the validity of the patents, and there seem to be strong hopes among those interested that the present decision will be like the former one. The decision of Justice Kay had a beneficial effect on the lamp-trade in England; prices have been reduced, and several firms have put new and improved lamps on the market. At the same time, if Edison is the original inventor of incandescent-lamp filaments, he should be entitled to the benefits of his invention. While the sustaining of a fundamental patent in any industry has a tendency to create a monopoly for a number of years, and restrict competition and decrease the rapidity of progress, yet the ill effect of a failure to sustain a just patent would have the still worse effect of discouraging invention. In the case of Justice Kay's decision on the Edison patents, the fact that the lamps made would not pay to manufacture commercially should have no weight, provided they first embodied the principle on which the present lamps are made; the only changes being in the improved methods and materials taught by experience, these improvements being merely in matters of detail.

THE DAFT MOTOR ON THE ELEVATED ROADS. — The Daft Electric Company continue their experiments with the large motor and trains of cars on the Ninth Avenue Elevated Railway in this city. Some weeks ago a train of eight cars was taken up a grade of nearly two per cent at a speed of seven miles and a half an hour. On several occasions a speed of thirty miles an hour, with three cars, has been reached. The regular train speed on the Ninth Avenue road is thirteen miles an hour, but with the electric motor no difficulty is found in maintaining a speed of fifteen miles an hour. A *Science* representative was one of a party, a few evenings ago, who were carried over the road from Fourteenth to Fiftieth Street at a speed approaching twenty miles an hour. The motion was smooth and easy, and there was nothing but the entire absence of smoke, smell, and cinders to indicate that the train was not drawn by an ordinary locomotive.

NOTES AND NEWS.

WE wish again to call attention to the monument for Audubon which it is proposed to erect over the place where he is buried. The authorities of Trinity Cemetery have changed the plot, and placed the remains in a well-constructed vault in one of the most conspicuous parts of the cemetery, and the committee in charge of the matter are anxious to have the monument erected as soon as the funds will justify it. Subscriptions are coming in very slowly. The committee have decided to distribute to each subscriber to the funds a copy of a portrait of Audubon which was painted by Cruikshank and engraved by Turnure. As this engraving is a copy of a very valuable and rare one, the committee hope that this will be an inducement to persons to subscribe.



John J. Audubon

— The American Society of Naturalists held in Baltimore, Dec. 27 and 28, one of its largest and most successful meetings. Methods of instructing large classes in botany were presented by Professors Goodale and Wilson, and in geology by Professors Niles and Williams. The society fully approved the excellent work of its committee on education, in paving the way for better instruction in the natural sciences in all grades of schools, especially the lower ones. Mr. J. E. Wolff showed a photographic method of class illustration, and Professor W. M. Davis explained a most interesting series of paper models, illustrating the development of certain topographic forms and their relation to base-levels of erosion. The society is composed largely of teachers, and desires to so arrange its meeting next year that the members may be able to attend the meetings of specialists held about the same time.

can institutions; and he has written one which will rank for years to come as the most thoroughgoing examination of them.

Professor Bryce's book will naturally be compared with the work of De Tocqueville, and it merits such comparison; yet it in some respects a greater book than that of the French student of our public life. If De Tocqueville made a philosophical examination of American institutions, Professor Bryce has made a scientific dissection of them. He enters into detail elaborately and accurately. He illustrates fully and freely. He rarely speculates. The book falls into three divisions, corresponding to the volumes as issued in the English edition. The first deals with our National Government; the second, with our State governments; and the third, with what, for want of a better term, we may call our politico-social institutions. Under the latter head are included the party system, public opinion, the bar and the bench, railroads, universities, and allied topics. The book is too large to be condensed, and too detailed to be described within the limits of a review: it must be read to be understood and appreciated, and it should be read by all classes of our intelligent citizens. It will serve to clarify the ideas of many people as to what our institutions really are, and how they work. It will make plain for the first time, to thousands of citizens who consider themselves intelligent, how public opinion is formed — or, rather, grows — in this country, how it finds expression, and how it rules. It will suggest to the careless democratic enthusiast certain points of weakness in our institutions, and certain dangers which we must sedulously strive to avoid.

Professor Bryce is unquestionably a democrat both by nature and by conviction, and an ardent admirer of democracy. This is perhaps the reason why some of the English critics have not been able to fully appreciate his work. It is the reason, also, which will serve to increase its popularity among our own people. It has been criticised abroad as too large, too diffuse, repetitious. It may be all of these; but these are merely defects of form, which the excellence of the matter more than counterbalances. That Professor Bryce's book will be widely read goes without saying. We can only add an expression of the hope that it may be intelligently read and pondered over; for it is a book that is meant to do good, and which will do good if it is read in the spirit in which it is written. We owe Professor Bryce a debt of gratitude for the time, the labor, and the patience that he has bestowed upon our national life. That his work will make us better known and better understood abroad, and better known and better understood by ourselves, is, we believe, a necessary result of its publication.

Aspects of Education. By OSCAR BROWNING, M.A. New York, Industr. Educ. Assoc. 16°.

The Slöjd in the Service of the School. By OTTO SALOMON. New York, Industr. Educ. Assoc. 16°.

Manual Training in Elementary Schools for Boys. Part. I. By A. SLUYS. New York, Industr. Educ. Assoc. 16°.

THESE are the three latest issues in the admirable series of educational monographs published by the Industrial Education Association of New York City, the growing circulation and general appreciation of which mark a gratifying public interest in matters pertaining to education. Mr. Browning's paper on "Aspects of Education" is known to readers of *Science*, inasmuch as its four chapters appeared in these columns some months ago. They are now rewritten and put together in a connected paper. As trenchant and accurate summaries of the movements apparent in modern educational thought, Mr. Browning's articles are not surpassed anywhere, and we are glad to find them reproduced in this permanent form.

Mr. Salomon, the author of the paper on "Slöjd," is well known as the director of the famous normal school at Nääs in Sweden. As the chief master of slöjd (sloyd), he is fully competent to treat it in its philosophic and pedagogic relations, as is done in the book before us. The translation by Dr. W. H. Carpenter of Columbia College is pleasantly done.

The third paper, by Professor Sluys of Brussels, is the most valuable and important yet issued, and we notice that Part II. of it will follow in March. Professor Sluys was the Belgian commissioner to

investigate and report on manual training, and his paper is full of citations of facts actually seen and known. The book is free from speculation, and is practical, complete, and unanswerable. We trust that it may fall under the eyes of such men as Superintendents Dickinson of Massachusetts, Marble of Worcester, White of Cincinnati, Gove of Denver, and Dr. Harris of Concord; for it will show them, impartially and dispassionately, how crude and unscientific their thinking on the subject of manual training is. We shall await the appearance of Part II. with interest.

The Roman Catholic Church and the School Question. By EDWIN D. MEAD. Boston, G. H. Ellis. 12°. 15 cents.

THE substance of this pamphlet consists of a lecture delivered before the Woman Suffrage League, Boston, but it has been expanded and revised for publication. It is a discussion of the question raised in Boston by the rejection, by the school committee, of Swinton's "History" as a text-book, the ground of the rejection being the opposition of the Catholics to Swinton's treatment of the sale of indulgences in the time of Luther. Mr. Mead here discusses the points at issue in an impartial spirit, and with a clear perception of the merits of the case. His style is not always so clear as might be wished, and shows marks of German influence; but, on the whole, the form and temper of the work are excellent. The address begins with a rebuke to the Protestants for some of the foolish things they have said during the late dispute, and intimates that their religion is not so decidedly superior to the Catholic as they are apt to suppose. But on the actual question at issue he takes strong ground against the Catholics, intimating pretty plainly that they opposed the use of Swinton's work for the sole reason that it tells the truth about the abuses once prevailing in their church. He condemns the parochial schools, and indeed private schools generally, holding that all American citizens ought to send their children to the schools maintained by the State. He then goes on to quote from certain Catholic school-books, showing how false to historical truth they are, not so much from actual misstatement as because of omissions, evasions, and exaggerated representations of what Catholics have done for the good of the world. To all persons interested in the questions at issue, and who realize the importance of correct teaching, the pamphlet will be of interest.

AMONG THE PUBLISHERS.

SOME of our readers may be interested in the second and third numbers of the new series of publications by the American Statistical Association. The former, by E. R. L. Gould, is on the subject of "Park Areas and Open Spaces in American and European Cities." Tables are given showing the number of open spaces in all the leading cities, with the amount of space and other items of interest. The author points out the importance of having many small breathing-spaces scattered about the city, especially in the quarters inhabited by the working-classes, and shows that many of our principal towns are deficient in this respect. It appears that some manufacturing cities have sadly failed of their duty, Pittsburgh having only one and a third acres of open space, and Scranton and some other towns none at all. Mr. Gould's general conclusion is, that the policy of American cities in this important matter has been very defective. The other paper is by Edward Clark Lunt, and is a "Key to the Publications of the United States Census." It gives a brief history of the taking of the various censuses, and then presents an epitome, or analysis, of all the census publications from 1790 to 1887. The different subjects dealt with in the census, such as population, races, agriculture, and so on, are treated separately; and under each head reference is made to the volume and page of each census report which gives information upon it. The United States census is so complicated a thing, and yet so important, that such help as Mr. Lunt gives must be of service to students of statistics.

— Professor Cleveland Abbe's "Treatise on Meteorological Apparatus and Methods" forms the second part of the "Annual Report of the Chief Signal Officer for the Year 1887," which has just been published. This admirable work is a handbook equal in value to Ferrel's theoretical meteorology and Hann's and Weicolf's cli-

matology, and supplements these works in a field in which a comprehensive and exhaustive guide to the student was most sorely needed. The plan of the book may be learned from the following passage of the preface: "A uniform thought has guided the arrangement of the chapters on the different instruments: namely, there is first given a general description of the object to be attained; second, a development of the formulæ for correcting the errors of the apparatus; and, finally, an indication of the refined methods of making standard determinations, to which all ordinary practical methods are to be considered as approximations." The volume treats of the measurements of atmospheric temperature and pressure, of the motion of the air, the measurement of aqueous vapor and of precipitation, while the subjects of optics, electricity, and actinometry remain to be presented in a subsequent volume.

— The lively discussion of the question of the influence of forests as regulators of rainfall and river-flow cannot fail to have a beneficial effect. Since the interesting discussion between Professor Fernow and Mr. Gannett which was published in a recent number of *Science* (xii. p. 242), Professor George F. Swain has given a comprehensive review of the subject in the *American Meteorological Journal*. The principal advance made in this investigation is the clearer understanding of the complexity of the phenomenon, and of the fact that the influence of forests cannot be the same in different climates, on plains, and on mountains, and that it depends on the genera and species composing the forest and on the covering of the ground in forests. While most American scientists hold that forests do not increase evaporation, Ebermayer and Woeikof claim the reverse. The latter even believes that this increase of evaporation is sufficient to effect an increase of cloudiness, and a consequent lowering of the temperature of summer. The only result that has so far been generally accepted is, that forests are regulators of the flow of rivers, on plains as well as in mountainous regions. This effect alone, setting aside the value of the wood, makes their protection of great economic importance.

— The number of the *American Journal of Psychology* just issued begins its second volume. The original articles that the first volume has contained demonstrate the profit of working the American psychological field, while the copious abstracts of current literature show both the activity of investigation elsewhere and the need of such a review as this department of the journal furnishes. The first article in the present number is on "Personal Equation," by E. C. Sanford, Ph.D. Astronomical methods early brought to light the vagaries of the human factor in observation, and since Bessel's discovery of personal equation the subject has received, at one time and another, the attention of many of the most distinguished astronomers. Their studies gave the impulse to the time-measurements in psychology that have been carried on with so much success by Wundt and others. Activity has also continued among the astronomers, and this paper is an attempt to turn to psychological account the results of their analysis and experimentation, and to bring together the results reached by both sorts of investigators. The history of personal equation (beginning with the notice of a difference in the observations of Maskelyne and Kinnebrook), and of the methods from time to time applied for measuring or avoiding it, makes an interesting episode in the history of science. In a second article the author proposes to treat the variations of personal equation, and discuss the theories of its origin. The second paper is the first section of an historical and experimental study of memory, by W. H. Burnham, Ph.D. The growth of the psychology of memory is traced from the earliest Greeks to Kant. In Plato are found the beginnings of that transcendental view of memory that make it a function of the soul independent of the body. The Neoplatonists St. Augustine and Leibnitz, neglecting individual variations, are of this party. Aristotle, on the other hand, who wrote a monograph on memory and developed the doctrine of association, is the father of Aquinas, Hobbes, Condillac, Bonnet, Hartley, and all those that see in memory only the traces of former sensations whose basis is in the end physiological. The special views of these and other philosophers, and their contributions to the theory of memory, are briefly stated by the author, as a basis, we suppose, for the presentation of modern views and the experimental treatment. It is true, that, while physiology and biology can now de-

clare that memory is in their field as well as in that of psychology, the germs of modern theories are to be found among the writings considered by Dr. Burnham. The practical side of memory receives attention in a short section on mnemonic systems. Dr. Mary Putnam-Jacobi contributes a paper on "The Place for the Study of Language in a Curriculum of Education." The first section attacks this much-debated question from a new standpoint; namely, that of cerebral physiology. The relations of language and cortical excitation are expounded at length, and the conclusion reached "that speech implies a more extensive excitation of the brain than does any action performed without speech." The acquisition of language in general has a distinct educating effect: it cultivates abstraction, and generally prepares the mind for its work. The acquisition of foreign languages in addition to the mother-tongue further complicates, extends, and refines the cerebro-mental processes. A comparison of mathematics and language shows the former to be valuable for constructing the syllogism, the latter for establishing the premises; in other words, for the details of every-day life. Between the study of things (that is, physical science) and language there is no antagonism. Language, properly studied, is rather a propædeutic to science. Between the time when the child is busy in collecting the sense-images of common things, and the time when he can return to them prepared for a genuine scientific study of them, is the period in which he should devote himself to language; not in the rote fashion, of course, but by a graded study, in which the scientific faculties of observation and induction are exercised on materials more accessible and more comprehensible than those of the distinctive sciences. By the age of sixteen the most of this work should be completed and out of the way; and, though language-study is not then to be entirely given up, the field will be free for other disciplines. The last part of the paper is devoted to practical suggestions for this kind of language-teaching. The reviews of psychological literature are, as before, one of the most important features of the journal. Nowhere else in English is it possible to secure such a conspectus of what is doing in the fields from which the new psychology draws its materials.

— On and after Jan. 1, 1889, the publication office of the Leonard Scott Publication Company will be transferred from Philadelphia to New York City, and the *Nineteenth Century*, the *Contemporary Review*, the *Fortnightly Review*, the *Westminster Review*, the *Edinburgh Review*, the *Quarterly Review*, the *Scottish Review*, *Blackwood's Magazine*, *American Naturalist*, and *Shakespeareana* will hereafter be issued from New York City. This change has been made to insure an earlier issue of these periodicals by the greater facilities thus secured for the importation of original sheets.

— The opening essay in the *Quarterly Journal of Economics* is by E. B. Andrews, on the subject of "Trusts according to Official Investigation." The facts presented are taken from reports of legislative committees and other governmental authorities, the object of the writer being to show what these organizations really are. Some difficulty was found by the investigating committees in getting at the exact truth on certain points, owing to the unwillingness of the witnesses to reveal it; but in the main the organization and working of trusts have been pretty clearly made known, and the leading facts relating to them are here set forth. The principal organizations dealt with are the Standard Oil Trust, the Sugar Trust, the Cottonseed-Oil Trust, and the Whiskey Trust; and on all of these Mr. Andrews's paper conveys a large amount of interesting information. With regard to the economic influence of trusts, the writer expresses himself guardedly; but he evidently thinks that they need watching. Professor Hadley discusses the subject of "Railroad Business under the Interstate Commerce Act," and shows that since the act went into operation the value of railroad property has depreciated twenty per cent. This he attributes to the prohibition of pooling, which prevents the maintenance of paying rates by the agreement between the companies; and he believes that a change in this provision of the law will eventually have to be made. Besides these two leading papers, the journal contains one by F. Y. Edgeworth on the question of whether gold has risen in value in recent years, on which, however, he reaches no definite conclusion. Mr. Simon N. Patten also has a

paper on "The Fundamental Idea of Capital," holding that capital is "every thing on which, labor being expended before the produce is wanted, the return will be increased beyond what it would be if the same labor had been exerted contemporaneously." The paper is of a rambling character, and the author's view is not presented with clearness. The journal contains the usual variety of miscellaneous matter, and closes with the first part of a paper on "Italian Finance," by A. B. Houghton, comment on which may be deferred till the appearance of the remainder.

— *The Open Court* for last week contains two articles upon the life and work of the late Mr. Courtlandt Palmer, the founder of the Nineteenth Century Club of New York City, entitled "The Universal Faith, an Address upon Mr. Courtlandt Palmer," by T. B. Wakeman; and "The Founder of the Nineteenth Century Club," by Moncure D. Conway. Professor Georg von Gizycki of Berlin, Germany, has two articles in *The Open Court* of Dec. 27 and Jan. 3, entitled "Death and Life," and "The Conservation of Energy in the Moral World."

— Mr. Daniel Greenleaf Thompson, the new president of the Nineteenth Century Club, and author of "The Problem of Evil," is about to publish an inquiry into the fundamental principles of social ethics and a discussion of the trend of social evolution. "Social Progress" is the title of his book, which will be issued shortly by Longmans, Green, & Co., both in London and New York. Mr. Thompson concludes by declaring his belief that social progress can be attained only through the perfection of social liberty.

— The first number (January) of the *Cumberland Presbyterian Review*—a quarterly magazine, devoted to theology, and the discussion of current religious, literary, and scientific topics, and questions connected with church-work and moral reforms, with J. M. Howard, D.D., as editor, and D. M. Harris, D.D., M. B. De Witt, D.D., and W. J. Darby, D.D., as associate editors—contains "Physical Basis of Moral Life," by President A. B. Miller of Waynesburg College; "The Family of God," by the Rev. W. H. Black, St. Louis, Mo.; "The Mosaic Doctrines of Death and After-Death," by Professor R. V. Foster of Cumberland University; "Preaching without Notes," by Rev. W. S. Danley, Lincoln, Ill.; "Charles Darwin," by Professor J. I. D. Hinds of Cumberland University; "The Pastor Getting Hold and Holding On," by the Rev. W. J. Darby, Evansville, Ind.; "The Philosophy of Missions," by Rev. D. E. Bushnell, Waynesburg, Penn.; "Our Senses: How We Use Them, and What They Tell Us," by John J. Tigert of Vanderbilt University; "The Decay of Christian Citizenship," by T. M. Hurst, Nashville, Tenn.; "Spirituality in the Church," by the Rev. P. Margeson, Marshall, Mo.; and "The Bible and Utility," by the Rev. J. D. Gold, Waukon, Io.; besides editorials, notes, and reviews of books. Single copies, per year, \$2.50; in clubs of five or more, \$2. Subscriptions should be sent to John D. Wilson, agent, 331 Church Street, Nashville, Tenn.

— Cassell & Co. will publish at once the fourteenth and concluding volume of the "Encyclopædic Dictionary." This work has been in preparation for nearly seventeen years, and extends to no less than 5,629 pages.

— D. Appleton & Co. publish a translation of Karl Marx's important work on "Capital," edited by Frederick Engels; also, in their Town and Country Library, "A Fair Emigrant," a story by Rosa Mulholland. Hereafter the volumes in this library will be put up in a neat cloth binding at 75 cents per volume.

— D. C. Heath & Co. publish for school use "Selected Poems of Wordsworth," collected and edited by A. J. George. The volume will contain lyrics, sonnets, odes, and narrative poems such as are requisite for a thorough understanding of the genius of the great poet. With the exception of the sonnets, which are grouped according to subjects, they will be arranged in chronological order. In the matter of annotation, only such material will be furnished as the pupil would not be likely to find elsewhere.

— *The Publishers' Weekly* states that A. D. F. Randolph & Co. have issued an edition of "The Thumb Bible," by John Taylor (born in 1580, died in 1654), commonly called the "Water-Poet."

Taylor, after fulfilling his apprenticeship to a waterman, seems to have served in the fleet under the Earl of Essex. Afterward he took up the trade of a waterman, and for a time was an excise collector. He was not really a poet, although he could string rhymes together with facility. At the approach of the civil war, he retired to Oxford, and was a publican. His sympathies were wholly with the Royalists; and when the town surrendered, he returned to London, and there kept a public-house. Here he died. He published "Verbum Sempereternum" (an epitome of the Old Testament in verse), dedicated to Charles I.; "Salvator Mundi" (an epitome of the New Testament in verse). These two were published in one volume in 1693, and dedicated to the Duke of Gloucester, etc., under the title of "Verbum Sempiternum," being an epitome of the Bible, termed from its size "The Thumb Bible." It was reprinted in 1849 by Longman & Co., London, and again during the present year by Hodder & Stoughton.

— D. Appleton & Co. have now ready the first volume of "An Illustrated Encyclopædic Medical Dictionary," to be completed in four volumes, compiled under the direction of Dr. Frank P. Foster, editor of the *New York Medical Journal*, with the collaboration of a dozen of the leading physicians of America. It is to be a dictionary of technical terms used by writers on medicine, physics, botany, chemistry, zoology, and other collateral sciences in the Latin, English, French, and German languages. Accuracy, convenience of arrangement, and comprehensiveness are guaranteed by the practical scholars in charge of this Herculean undertaking.

— "The literary executor of Theodore Parker," says the *Boston Transcript*, "is preparing a new edition of his 'Historic Americans,' in which there will be added to Franklin, Washington, John Adams, and Jefferson, Parker's sketches of John Quincy Adams, Dr. Channing, and Webster. The volume will be twice as large as that edited by Octavius B. Frothingham, in 1870, and will contain a larger introduction and more frequent notes. Each biography will be short, not running beyond seventy-five pages, and these will contain the verdict of Parker on the life, character, and results of all of these great Americans, whose career covers the period from 1740 to 1850, or more than a century. The volume will be followed next summer by Parker's autobiography, — a work essentially new, though made up largely from materials published by himself and others from 1850 to 1875. Many passages from the diary and letters will be given, however, which have never been published, relating to Parker's acquaintance with Alcott, Emerson, Margaret Fuller, Bettine Brentano, Garrison, Wendell Phillips, and other contemporaries."

— Sampson Low & Co. have in preparation "A History of English Bookselling," by William Roberts.

— A work to be issued by the Cambridge University Press is "The Literary Remains of Albrecht Dürer," by W. M. Conway. The volume will contain transcripts from the British Museum manuscripts, and it will be illustrated.

— "The Villon Society," says the *Academy*, "will shortly issue an addendum to their edition of 'The Thousand Nights and One Night.' The new volume will contain the stories of Aladdin and Zeyn el Asnam, translated from the newly discovered Arabic text by Mr. John Payne."

— The Geographical Society of St. Petersburg has just issued a superb edition of the last work of Gen. Prjevalsky, entitled "From Kiakhta to the Sources of the Yellow River," an exploration of northern Thibet and the route across the basin of Tarim by Lob Nor. The book gives portraits of the author and his companions, and many maps and illustrations. Like all work done by this lamented author, it is exhaustive and scholarly, and a convincing proof that the untimely death of the writer is a great loss to Russian science.

— The readers of *The Popular Science Monthly* will be glad to learn that Dr. Andrew D. White's "New Chapters in the Warfare of Science" are to be resumed in the February number. Dr. White has devoted several years to the investigation of this subject, and is now in Europe making an examination of the libraries there for additional material, which shall enable him to continue his ac-

count of the persistent dominance of delusion in the human mind. The chapter immediately forthcoming will treat of "Demoniac Possession and Insanity."

— The way the Interstate Commerce Law looks from the side of the railroads will be shown in the February *Popular Science Monthly*, by Mr. Appleton Morgan, in a vigorous article entitled "The Political Control of Railways: is it Confiscation?" Mr. Morgan maintains that this act, by prohibiting pools, nullifies its other prohibition of discriminations; in fact, increases discrimination, when the whole people is regarded.

— "The Story of a School" is the title of an article by the late Professor James Johannot, to appear in the February *Popular Science Monthly*. It is an account of the success achieved in conducting a normal school according to natural methods, arranging the subjects of study in their order of dependence, teaching science by observation, language by using language, mental and moral philosophy objectively without books, and with no marking system, rules of discipline, or distinctive religious exercises.

— *The American Queen*, a monthly magazine for the home, is published by the First National Publishing Company (John C. Rand, president), 131 Devonshire Street, Boston.

— We have received from F. W. Christern & Co. (New York) the first number of *L'Exposition de Paris* of 1889. It contains, among other things, a large bird's-eye view of the exposition grounds and buildings, pictures of the chief and assistant engineers and architects, including M. Eiffel, general and detail views of the 300-metre tower now being erected by the latter gentleman, and a prospectus of the exposition. Forty numbers of the publication will be issued during the progress of the exposition, at ten cents a copy.

— An extra December number of the Riverside Literature Series (Houghton, Mifflin, & Co.) is devoted to "Dialogues and Scenes from the Writings of Harriet Beecher Stowe," arranged for reading-exercises and dramatic representation, by Emily Weaver. Care has been taken to adhere to the original text as closely as possible; and, to make the dialogue clear and to explain the action, explanatory passages from the books in which the dialogue occurs are added from time to time. The dialogues are taken from "Uncle Tom's Cabin," "Old Town Folks," and "The Minister's Wooing."

— In a copiously illustrated article in *Frank Leslie's Illustrated Monthly* for January, Lieut. F. S. Bassett, U.S.N., traces the evolution of the rudder, from the primitive paddle with which the savage both propels and guides his dug-out or birch-bark canoe, to the modern steam or hydraulic steering-gear of the great ocean steamships. The illustrations, which are drawn from early monuments and coins, and mediæval frescos and paintings, show the change in method of steering, from that in which the blade of the oar or paddle is moved bodily through the water in a nearly horizontal plane, to that in which the vertically placed successor to the oar-blade, the rudder, is merely turned upon its axis. An interesting fact mentioned in the article is that one of the most recent improvements in steering apparatus is a reversion, on a higher plane, to the most primitive method, a swinging propeller both driving and guiding the vessel, as did the paddle in the hands of the savage. An article somewhat similar in nature to that of Lieut. Bassett's, though more limited in scope, is published as a supplement to *Harper's Weekly* of Jan. 5. It is entitled "The Evolution of the Ferry-Boat," and is from the pen of S. Bayard Dod. Though dealing only with the ferries and ferry-boats of New York, it contains much to interest the general reader. Beginning with the first licensed ferry on the North River, that between New York and Communipaw, in 1661, when the fare was "six stivers a head Wampum for every passenger," and the boat was propelled by oars or sails, Mr. Dod follows the growth of the ferries down to the "horse" stage, when the boats were propelled by paddle-wheels actuated by horse-power, and then to the introduction and development of steam ferry-boats, ending with a description of the latest triumph of ferry-boat architecture, the "Bergen,"— a steel boat, with fifteen water-tight compartments, and a propeller at either end, to take the place of the paddle-wheels which have prevailed heretofore in such boats. Either a slip of the

pen or a printer's error makes Mr. Dod say that the walking-beam low-pressure engines in general use "have gradually increased in size, from 25-foot diameter of cylinder with 5-foot stroke, to 46 and 50 inch cylinder with 10-foot stroke."

— Professor J. H. Gore of the Columbian University has in preparation a bibliography of geodesy. During two trips to Europe he has collected about seven thousand titles, having examined nearly every large library except that at St. Petersburg. He begins with the first effort to ascertain the shape of the earth by triangulation in the seventeenth century. The work will be published soon by the Coast Survey. Professor Gore is trying to make his service complete by personal application for data, he having written to all astronomers and other mathematicians in the world whose addresses he could obtain. He asks *Science* to say that the co-operation of its readers is desired.

— Dr. C. A. White has just prepared a bulletin for the Geological Survey, on "The Permian of Texas," adducing some facts not hitherto published, in recognition of the Permian in North America, and exhibiting some fossil forms not hitherto known to exist on this continent, and a commingling of paleozoic and mesozoic types similar to those discovered by Waagen in the Salt Range of India.

— The *London Globe* of Dec. 4 describes a new plan for the lending of books. The circulating library is now an important element in English life, and, widely spread as are its ramifications, it is possible seemingly to extend them even further. The experiment, at any rate, is to be made in Austria-Hungary and on the railways there. In England Messrs. Smith & Sons have a circulating library in connection with their book-stalls, but they do not lend books for perusal on the journey only, charging a fee and taking the volumes back again at "the other end." Yet this is precisely what the Austrian firm propose to do. The traveller will be required to pay a deposit which shall cover the price of the book lent, and also a small charge, amounting to about threepence in English money. He will choose a volume on starting, and return it on arrival at his destination, where he will receive the sum deposited. No doubt the project will succeed, if the supply of books is found satisfactory by the voyager.

— From the *Pall Mall Gazette* we learn that Miss von Hoerschelmann's two-volume "Kulturgeschichtlicher Cicerone für Italien-Reisende" has had the rare distinction in Germany of being by special permission dedicated to the Empress Frederick, before whom and the Emperor the lady has repeatedly lectured. Like every thing else in Germany, the dedication of a literary work to a member of the imperial family is connected with an incredible amount of red tape. There is a codex in the laws relating to the imperial household according to which no scientific work may be dedicated to any member of the imperial family unless it comes up to a certain standard. A number of *savants* "sit upon" each work of this kind, and determine whether the dedication is to be or not to be. One of the conditions is that the work shall contain views or discoveries hitherto not dealt with. Miss von Hoerschelmann's Cicerone could naturally not lay claim to this distinction, and it was owing to a special interference of the Empress Frederick that her two volumes passed the censor and were dedicated to her Majesty.

— The Aldine Book Publishing Company state that they have sold nearly 10,000 copies of their "Europe Illustrated."

— The Library Bureau, Boston, announces to subscribers to the "Decimal Classification," that, after many unforeseen delays, the complete tables and index of 20,000 entries was printed last month, and will be in from the bindery this week. The regular edition, containing the introduction, cannot be had from the bindery till after the holidays, possibly by Jan. 30. Those in special haste may obtain now the tables and index bound, and in January the introduction in pamphlet form.

— According to *The Publishers' Weekly*, Col. Wright, the commissioner of labor, expects to send two volumes to Congress before the present session closes. The first will be the fourth annual report of the Labor Bureau, and will be devoted to the working-women in the great cities. The other volume will be the report

on divorces and divorce laws, for which a special appropriation was made by Congress. The records of 2,700 courts have been examined; and the volume will give, in classified form, the number of divorces, with causes, number of children, when divorced, and other accessible information. The agents of the Department of Labor are now at work on the fifth annual report, which will not be ready for a year yet, on the wages of railroad-men.

—“Mr. B. F. Stevens, 4 Trafalgar Square, London, has been for some years at work on indexes to the manuscripts relating to American affairs between 1763 and 1783 preserved in European archives. The United States Government urged the purchase of these indexes, and also the obtaining of transcripts of the documents themselves. Congress has, however, made no grant for the purpose, and Mr. Stevens therefore boldly proposes to publish photographic facsimiles of the documents, provided he can obtain a hundred subscribers to begin with. Each document will be accompanied by a statement of its *provenance*, and of any variations to be found in other copies, if such exist; and a translation will be added when the original is not in English. Mr. Stevens calculates that when he has once fairly started he will be able to publish monthly two volumes of some 500 pages each, and he asks \$100 for every five volumes. A copious index will be published to every twenty-four volumes, and the price of it will be \$20. Mr. Stevens thinks that this valuable series of facsimiles will ultimately fill 100 volumes.”

—Columbian University has announced a unique course of lectures for the coming months, on “The Human Emotions from an Anthropological and Psychological Point of View.”

—At the meeting of the Philosophical Society on Jan. 5, obituary notices were made of Peter Parker, E. B. Elliott, F. V. Hayden, Roland D. Irving, Thomas Hampson, and Emil Bessels; and Mr. Bailey Willis read a paper on “The Mechanism of the Overthrust Fault.”

LETTERS TO THE EDITOR.

*.*Correspondents are requested to be as brief as possible. The writer's name is in all cases required as proof of good faith.
Twenty copies of the number containing his communication will be furnished free to any correspondent on request.

Two Discoveries in Human Osteology by the Hemenway Expedition.

I HAVE the honor of enclosing to you a letter handed me by my friend Professor Edward S. Morse, who deems the matter therein discussed by Mr. Cushing of such importance as to merit prompt announcement in your journal.

First, however, I will ask leave to mention briefly another important discovery made during the researches of the Hemenway Expedition in the Salado and Gila valleys in southern Arizona last winter and spring. In the summer of 1887 Mr. Cushing, the director of the expedition, was dangerously ill at Camp Hemenway, on the site of the prehistoric city of Los Muertos. Through the kindness of Secretary Endicott and Surgeon J. S. Billings (the director of the Army Medical Museum at Washington), Surgeon Washington Matthews (the curator of the museum and an intimate friend of Mr. Cushing) was ordered to Arizona to his relief and assistance. Dr. Matthews, whose arrival at Camp Hemenway was just in time to save Mr. Cushing's life, was so much impressed with the character of the ancient skeletons there exhumed, that, as an anthropologist, he perceived that it would be of immense scientific value to have them preserved in the most careful manner possible. On his return to Washington, he represented the matter to Dr. Billings, who at once detailed Dr. J. L. Wortman, the talented comparative anatomist of the museum, to assist the expedition in properly exhuming and preserving the skeletons. It is a notable fact, that, with few exceptions, the skeletons in the various museums of the world have been carelessly collected, and are therefore worthless in the study of certain features: therefore the importance of having this work proceed under the supervision of two such men as Drs. Wortman and ten Kate, the latter the anthropologist of the expedition, may be perceived. Fortunately the expedition had also three or four Mexican workmen of such native intelligence, that, under the training of the two doctors, they became highly expert in the recovery of the skeletons, complete in every detail; the great

age of the remains rendering them very fragile, and demanding, therefore, extremely careful manipulation.

Early in the course of the work, Dr. Wortman observed indications of a remarkable anatomical peculiarity in the remains. Calling the attention of Dr. ten Kate to the fact, together the two pursued the investigation of the same, and all subsequent observations thoroughly confirmed their first inference. This fact was, that in this race the hyoid arch, or basi-hyoid, which together with the stylo-hyoid forms the bony structure at the base of the tongue, was not in the adult co-ossified, the three small bones forming the arch remaining free through life; the only exception being in the case of skeletons bearing marks of bone-disease, exhibited in the co-ossification of various articulations, in which cases the bones of the basi-hyoid were apt to be ankylosed, though occasionally on one side only. The strongest evidence was that exhibited by the skeletons of old persons, which proved no exception to the general rule of this observation.

This peculiarity was contrary to all the former experience and studies of the two observers, and it indicated the discovery of a pronounced racial character; for, according to what they had hitherto learned concerning this feature, the ankylosis of the basi-hyoid took place either at or before middle life.

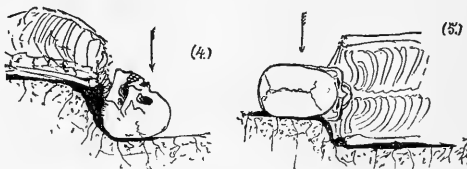
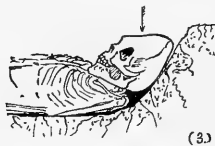
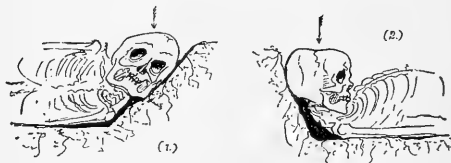

Consulting the literature of the subject, it was found that both the English and French anatomical authorities concurred in this view, while the German authorities held that the several bones of the arch remained free, ankylosis taking place only exceptionally or in extreme age. It was inferred that the German view was either based upon insufficient evidence, the conclusion being drawn perhaps only from the anatomy of young persons, or that the anatomy of the German race differed in this respect from that of the English and French.

These observations were embodied in a brief preliminary paper by Drs. Wortman and ten Kate, and communicated to the International Congress of Americanists held in Berlin last October, at which Professor Morse and I had the honor of representing the Hemenway Expedition. The paper was read to the congress by Professor Morse, who illustrated it with blackboard-drawings. The subject occasioned much interest, for it was felt that it would prove to be of extreme importance should it turn out to be a peculiar feature of the aboriginal race of the American continent, as was indicated. Subsequent examinations of a large number of skeletons exhumed from ancient ruins during the excavations of the Hemenway Expedition at Zuñi, where it is now at work, have uniformly supported this view; and while we were in Berlin a Pe-

ruvian mummy was placed at the disposal of Professor Morse by Dr. Wilhelm Reiss, the learned president of the congress, and the discoverer, in association with Dr. Stübel, of the famous Ancon antiquities. An examination of this mummy, which was that of an elderly person, showed that the elements of the hyoid arch were free.

When the attention of Professor Virchow was called to the subject by Professor Morse, that eminent anatomist said that the question had apparently been entirely neglected. He was inclined, however, to support the correctness of the view advanced by the German authorities, and regard the co-ossification of the hyoid arch as occurring only under abnormal or pathological conditions.

Returning home by way of London, while visiting the British Museum of Natural History, we had the good fortune to meet the eminent mammalogist, Professor Flower. When we called his attention to the subject, he expressed the liveliest interest, saying that the observation was entirely new, the separation of the bones of the basi-hyoid being wholly contrary to any thing observed in his own large experience. He had taken the pains of making careful observations of this feature, and had made preparations of full sets of the *os hyoides* both in man and the lower mammalia. In man he had found that co-ossification took place at maturity, and in proof he called attention to a complete series of British hyoids which he had prepared for the College of Physicians and Surgeons. Therefore he would regard this observation of Drs. Wortman and ten Kate as indicating a very important discovery. The collection of human hyoids at the College of Physicians and Surgeons was inspected by Professor Morse, who found it prepared with the skill and knowledge for which Professor Flower is famous. Every specimen, when after maturity, was co-ossified.

Under a co-operative agreement made at the time between the Army Medical Museum and the Hemenway Expedition, the skeletons exhumed from the ancient cities in southern Arizona have been deposited with the former institution; and Dr. Billings is so impressed with the importance of the question, that Drs. Matthews and Wortman have been requested to make it the subject of an exhaustive research. In this work they, with their assistants, are now engaged, and have been supplied with an abundance of material from various races, in order to make the needed comparative observations. A full report thereon will be forthcoming in due time, but it may already be stated that the investigations have been advanced to a stage that fully confirms the opinion originally formed by the observers,—that in the peculiarities of the *os hyoides* is to be found the most distinctive racial character yet observed in human osseous anatomy. Its value in the determination of vexed questions can hardly yet be estimated, but it will undoubtedly prove of great anthropological service.

Dr. Wortman inclines to the view that it will be found that language plays a leading part in determining the form of this feature. The language of the American Indians is such that it requires but slight effort in utterance. An Indian can talk for hours at a stretch with little fatigue, and even a superficial observer will notice the restrained quality of the voice, the tones not being projected as with us. Now, the development of ankylosis being held to proceed from exercise, or irritation of the bone, from muscular action or otherwise, it is evident that in a language like that of the Indians there would be less muscular action exerted upon the hyoid arch than in one like ours, where more force is used, and therefore the co-ossification of the parts would be less encouraged. This view of Dr. Wortman's obtains support in observations made by Mr. Cushing at Zuñi, where he finds that the voices of those who are afflicted with bone-disease differ in quality from those of the tribe at large, and infers that their difference may be due to co-ossification of the hyoid brought about by the disease.

With the foregoing remarks, I hereby submit Mr. Cushing's letter concerning the other important osteological observation mentioned in the beginning.

SYLVESTER BAXTER,
Sec'y Hemenway Expedition.

OLD FARM, MILTON, MASS.,
Nov. 9, 1888.

My dear Morse,—Last evening I chanced to tell Mrs. Hemenway something about the observations we made on the distorted skulls of

Los Muertos and Halonawan. She was greatly interested, especially in what Baxter had to say relative to Dr. Virchow's paper before the recent congress, on, I think, deformed American crania. She wished me to write a brief statement of the case and send it to you, as of possible use to Drs. Virchow and Bastian.

While our excavations were in progress, I observed, by keeping close watch over the disinterments, that all, or nearly all, skulls occurring in earth sepulchres, were apparently deformed by artificial means. From the fact, however, that skulls taken from stone graves or cists, or from other sorts of tombs wherein they had been fairly protected, were uniformly and regularly brachycephalic, and showed no other sign of distortion than the occipital flattening from the cradle-board, I was led to infer that those from the earth sepulchres had been deformed by accident; that is, by post-mortem influences.

Subsequent observations, in all of which I was confirmed by Dr. ten Kate, indicated the entire correctness of this inference. For example: no general rule of cranial disfiguration (always with the above instanced exception) was found to prevail. On the contrary, the disfigurations seemed to depend largely, if not wholly, on the positions of the skulls. When the latter were lying on their sides in the graves, at an angle of, say, forty-five degrees, one side of the coronal region would be depressed, and sometimes the face, even, would be obliquely distorted, as in Fig. 1 of the accompanying slips. Again, when the skeleton was lying on its back, with head elevated, the crown would be greatly depressed, as in Fig. 2; or, if the head happened to be less elevated, face partially upturned, the frontal region was invariably more or less flattened and broadened, as in Fig. 3; or, if, finally, the head chanced (face still upward) to be greatly depressed, the parietal region was flattened, throwing the frontal forward sometimes to an extraordinary degree, as in Fig. 4.

Perhaps the most extreme of these cases of post-mortem distortions of skulls were those which, belonging to skeletons of persons who had been buried on their sides, were so regularly flattened laterally that they seemed unmistakably to belong to the dolichocephalic class, as in Fig. 5. In fact, the only examples of "long-headed" skulls found during our researches, in either the north or the south (among the ancient ruins, that is), were so plainly distorted by this post-mortem pressure, that they made no exception to the rule established by Dr. ten Kate, that the Pueblo or Aridian was a short-headed race.

All this is simply due to the practice of blanket-burial. The skulls, being unprotected during the earlier years of burial, are, by the pressure of the earth, gradually deformed,—so gradually, indeed, that they neither crack, nor do the sutures part. The deformities are therefore in no wise distinguishable, after the specimen is removed from its original resting-place, from those produced by art. We are now, therefore, forced to note, in collecting our crania, their relative positions in the earth sepulchres very carefully.

I sincerely hope this may prove useful to Drs. Bastian and Virchow, or at least of some interest to them and the many other gentlemen who were so courteous to you and Mr. Baxter.

Faithfully yours,

FRANK HAMILTON CUSHING.

The Julien Electric Traction System.

IN the opening pages of your journal of Dec. 21, 1888, a description is given of the Haus Electric Railway, and comparisons are made between that system and other systems of electric traction. A paragraph is devoted to pointing out what the writer claims to be the defects of the storage-battery system.

It is very much to be deplored that some electrical railway companies attempt to raise their own systems in the public estimation by crying down other systems. What is still more deplorable is, that, in attempting to do this, they are not always friends to truth. There could be no better proof of this than the paragraph I have above referred to on the storage-battery system.

The writer admits that the storage-battery plan "would seem to be the ideal system," for the reason, among others, that "it dispenses with the necessity of a continuous conductor, the electrical generator and motive power are all contained within the car, and there is apparently an entire absence of any possibility of danger to the passengers." The writer goes on to say that "these favorable anticipations would be justified were it once demonstrated that a storage-battery had been devised that was economical of power, of reasonable weight, and durable in service." The writer

then goes on to say that "the best storage-battery that has been devised is very wasteful as a source of motive power, yielding at most but forty per cent of the power applied." Now, nothing could be further from the truth than this statement. There is probably not a storage-battery at present on the market that will not yield eighty per cent of the power applied. Almost any person of electrical knowledge and experience knows this to be a fact; and, if further proof be necessary, it will afford me much pleasure to have you send an expert, at my expense, to the electric station of the Julien Electric Traction Company, 85th Street and Madison Avenue, this city, to verify for himself the truth of this statement. He can there see for himself the number of watts the battery receives from the dynamo; and, if the battery does not discharge over eighty per cent of the watts so received, you are welcome to publish the fact to the world.

The next objection the writer raises to the storage-battery system is, that it is "excessively heavy and bulky, making it necessary to carry about three times the load of an ordinary car." Now, "the load of an ordinary car" (16-foot car) is 3 tons: consequently a storage-battery car would have to carry 9 tons of battery, if we are to believe the writer. Now, Car No. 3 of the Julien Electric Traction Company, at present running on Fourth and Madison Avenues in this city, carries just 120 elements, or cells, of battery, each element weighing exactly 27 pounds, or 3,240 pounds; or, with the trays and containing-boxes, 3,600 pounds,—a little over 1½ tons, instead of 9 tons, as the writer would have us believe. Let me add, in connection with the weight of a storage-battery car, what every engineer knows, that in a locomotive (which the storage-battery car is), to have adhesion, you must have weight.

The 120 cells above referred to contain 52 horse-power hours, and will carry that car over the streets of New York, without being recharged, for a distance of at least thirty-six miles, and carrying over four hundred passengers in all. If the Hauss Electric Railway is now doing equally acceptable and economical work, it would be very interesting for the public to know it. The writer omitted, by the way, to state where the Hauss electric system may be seen, and what practical experience, if any, it has had.

The writer goes on to say that the storage-battery system requires a special car to be built, to provide the necessary space beneath the seats to receive the battery. This is equally untrue. Car No. 3, above referred to, is an old horse-car, and was altered at an expense of about two hundred and fifty dollars for its present purpose. The alteration required is the lifting of the car-body, some five inches above its present position.

The next objection the writer has to the storage-battery is, that it "has a life of only two years of constant service, and it is subject to the danger of short-circuiting, which at once destroys its usefulness." The remark as to short-circuiting is very amusing. Am I to understand that the motors constructed by the Hauss Electric Railway (if they do actually construct any) are not subject to the danger of short-circuiting? If so, we must assume that their usefulness is destroyed. Now, we all know that the experience of every electric railway in the country is that the electric-railway motor has the same tendency to short-circuit that the most peevish mule has to kick. If the short-circuited motors of 1888 were made a pile of, we should not need to go to Egypt to see a pyramid. The fact is, that, since the fifteenth day of September last, up to the present moment, we have not short-circuited a battery in our street-car service, although our cars have run in that time in passenger-service some seven thousand miles. This storage-battery short-circuiting is a thing of the past. The cells are at present so connected that short-circuiting is impossible; for the connector would be blown out of position by an excessive current, and thus save the battery. We should be pleased to have you verify this at our station in this city. The writer gives our battery "only two years of constant service." We thank him for that concession, for we only ask six months' constant service in order to compete with the cost of horse-traction. He probably forgets that the material in the battery is not destroyed when the "usefulness" of the battery ends, but is again made over into battery by a process so cheap as to compete favorably with the maintenance of horses.

One word more, Mr. Editor, and I have done. Our 18-foot cars,

Nos. 1 and 2, now in the service of the Fourth and Madison Avenue lines, in this city, run from 86th Street and Madison Avenue to the Post-Office, and back,—a distance of twelve miles,—on an expenditure of less than fifteen horse-power hours of energy, and frequently carry over two hundred passengers on the round trip. This seems almost too good to be true; but you would do us a favor by inspecting the records at our station, and verifying this statement for yourself. With storage-battery traction there can be no mistaking the amount of energy expended; for we know the number of horse-power hours that are put into the battery, and of course the number of miles such charge will carry the car. Now, for the information of the public, we think it but fair that the Hauss Electric Railway should tell us how far fifteen electrical horse-power hours has carried one of their cars. The comparison would be very interesting.

WM. BRACKEN.

New York, Jan. 5.

The Soaring of Birds.

IN a recent number of *Science* (xii. p. 267) I notice an article under the above heading. It seems to me that we have not yet got to the bottom of the matter, and that the true explanation of the phenomenon is still simpler. Imagine a piece of paper floating in the air. The wind takes it, and carries it along horizontally with its own velocity. After it has assumed the velocity of the wind, there is but one force acting on it; namely, the vertical one due to its own weight. Imagine now a bird under the same circumstances. Instead of travelling with the wind, as everybody who has watched a

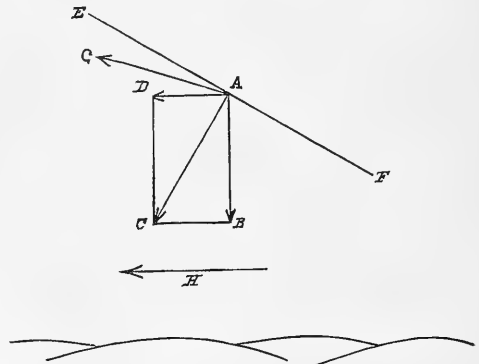

soaring bird knows, he travels round and round in circles, each one a little higher than the last, and each one a little farther along in the direction towards which the wind is blowing. Now, when he travels with the wind, he attains nearly its velocity, and then turns and travels against it, rising rapidly at the same time, till he is nearly stationary, or perhaps is even going a little backwards, relatively to the ground. He then turns and travels with the wind again, either moving along horizontally, or perhaps dropping somewhat nearer the earth, until he attains his original velocity, when the cycle is repeated. Comparing his motion with that of the paper, we find that he does not move along so fast: there must, therefore, be some compensating advantage obtained, in order to use up the surplus energy derived from the wind.

In the above figure let *H* represent the direction of the wind, and *A* the position of the bird. Let *AB* represent the force due to his weight, and *AD* the mean force exerted on him by the wind, owing to the fact that he does not move along as fast as the surrounding air. Combining these, we get the resultant force *AC* acting upon the bird. Now construct the plane *EF* perpendicular to the line *AC*. The bird may then move anywhere in this plane without losing energy. He cannot move to the right of it, but he may move to the left, and thus gain energy. Practically he will move in a spiral about the line *AG*, thus slowly dropping from the plane

EF, but gaining enough energy by that means to make up for that lost by friction with the air. He will thus gradually rise from the earth, and at the same time drift along with the wind.

WM. H. PICKERING.

Harvard College Observatory, Cambridge, Jan. 1.

The Great Lake Basins of the St. Lawrence.

THE following are the conclusions of a paper under the above title to appear during January in the *Canadian Record of Science*, and the object of which is to suggest what has been the origin of the present contours of the Great Lakes:—

That glaciers, while contributing some results, had not much effect in eroding the lake-basins proper, or in shaping the present general outlines.

That the superficial deposits are the accumulations of denudation during immense periods of time since the carboniferous and earlier eras, and are not to be specially credited to the operation of glaciers.

That Lake Superior is the most ancient of the lakes, dating its origin as far back as Cambrian, Keweenawan, and Huronian times; that it is, in part at least, a synclinal trough; that volcanic action has had most to do with its origin and the shaping of its coasts; that its early outlet was through the depression in Whitefish Bay; and that its waters joined the great pre-glacial river system at or near the Straits of Mackinac.

That Lakes Michigan, Huron, and Ontario were originally the bed of a pre-glacial river which first crossed the Ontario peninsula along the Niagara escarpment, and afterwards was diverted to a course by way of Long Point, Lake Erie, and the Dundas valley; that their basins were largely defined by the elevation of the Niagara and Hudson River escarpments, and in more recent times by warping of the strata and deposit of superficial sands and clays which blocked the old river-channels and resulted in the lake-basins retaining their water on the final elevation of the land to its present general levels.

That the pre-glacial river system expanded into lakes of some size in each of the present basins of Lakes Michigan, Huron, Erie, and Ontario.

That Lakes Erie and St. Clair are the most recent of the lakes, and have at one time been more closely united; and that the formation of this united lake was due to the blocking of the old outlets both by superficial deposits and warping of the strata, and to the water being thus retained in the basin on the final elevation of the land to the levels of to-day.

That great fractures at or near the outcrops of the strata occasioned by the directions of the forces which elevated the strata, originated, in many instances, the deep bays and inlets which indent the Niagara and Hudson River escarpments, and rocky coastlines of Lakes Michigan and Huron; these effects being afterwards supplemented by the action of waves, currents, atmospheric causes, and probably local glaciers.

That since the elevation of the land to the levels of to-day, the action of waves and currents on the clay cliffs and sand deposits has in many places greatly rounded off the general outlines of the coast, and the material from this and other sources has been spread over the lakes, or has served to create new features in the coastline elsewhere.

A. T. DRUMMOND.

Montreal, December, 1888.

Color of Katy-did.

THERE has recently come into the possession of the writer a specimen of the Katy-did showing a remarkable variation in color. The whole body is of a beautiful and delicate rose-pink. The specimen, when captured, did not seem to be abnormal in any other respect. It has been identified by a member of the entomological division of the Agricultural Department as *Phylloptera oblongifolia*. It seems to be a rare variation, though from the same gentleman we learn that at least one similar case has been recorded. A specimen exactly like this one in color is mentioned by Riley in his "Sixth Report on the Insects of Missouri" as having been sent to him many years ago.

L. N. JOHNSON.

Evanson, Ill., Dec. 30.

Various Definitions of Manual Training.

AN article in *Science* of Jan. 4, under the caption of "An Authoritative Definition of Manual Training," embodies an abstract of the report of the special committee on manual training of the New Jersey Council of Education, the semi-annual meeting of which body was recently held at Trenton, N.J. The committee, in concluding its report, submitted the following resolution, which was unanimously adopted:—

Whereas there are several and conflicting uses of the term "manual training," be it hereby

Resolved that the New Jersey Council of Education defines "manual training" as "training in thought-expression by other means than gesture and verbal language, in such a carefully graded course of study as shall also provide adequate training for the judgment and the executive faculty." This training will necessarily include drawing and constructive work, but experience alone can determine by what special means this instruction may best be given.

From an educational standpoint, the definition of "manual training" formulated by the committee would appear to be indisputable; but that the definition, supported as it is by the broad pedagogic principles which underlie it, will be universally accepted as authoritative and final, is not as certain as that the definition is such as to best subserve true educational aims. At least, it is safe to say that thousands of educators and school-officers must eliminate from their minds the impression that manual training has for its object the learning of a trade or the acquisition of mechanical skill alone, ere the definition given by the committee can have free course.

Again: there are others who are unwilling to accept the *dicta* of schoolmen, and who insist upon the mere technical or industrial phase of manual training, and can see nothing beyond it. Any thing that does not centre in this is, to them, an indubitable evidence of inutility. Training of thought, of judgment, of expression, etc., as educational stimuli, do not as potent factors enter into their conception of the aim and end of manual training.

That the training of the school workshop has a reflex influence upon the traditional occupations and "studies" of the classroom, causing pupils to reflect, to compare, to be careful and exact in these also, has not thus far been taken into the estimate of the worth of manual training as generally as the facts warrant; for manual training is not that of the hand alone, but of the intellect as well.

The joint training of the mental faculties and the hands tends to dignify the labor of the latter,—the form of labor which by many is alone recognized as "work." But it does not end there: it affords at the same time opportunities for the discovery of latent inventive or mechanical genius, and, when such discovery is made, serves as a guide in the choice of employment.

One must necessarily lead an unsatisfactory and precarious existence, who, from a false estimate of the relative respectability of two or more employments, chooses that for which he has but little natural aptitude and less acquired skill. And is it not true that the popular education of the past has tended toward the making of such choices? Has it not tacitly inculcated the idea that professional employment—the law, medicine, the pulpit, or the professor's chair—is the "chief end of man" according to the creed of the schools? In numberless instances such choices have been made, with the attendant and natural result of dismal failure.

As a corrective, manual training brings to bear a species of craniology which will eventually develop a more rational creed; and this view of manual training I conceive to be entirely compatible with the definition which the committee on manual training formulated.

O. M. BRANDS.

Paterson, N.J., Jan. 7.

Color-Blindness.

A SHORT time ago I tested the color-perception of forty-two boys who had had kindergarten training. Their ages were from nine to fifteen. Not one of them made an error in matching colors. They were not asked to name them. This result suggests further investigation upon this class of pupils, not only to add one more fact to our knowledge of color-blindness, but also to determine the value of early instruction in colors.

ARTHUR STEVENS.

Jefferson, N.Y., Jan. 6.

Publications received at Editor's Office, Dec. 31-Jan. 5.

ALLEN and GREENOUGH'S Latin Grammar. Rev. by J. B. Greenough. Boston and London, Ginn. 488 p. 12^s. \$1.35.

BLAVATSKY, H. P. The Secret Doctrine: The Synthesis of Science, Religion, and Philosophy. Vol. I. Cosmogony; Vol. II. Anthropogenesis. London, Theosophical Pub. Co.; New York, W. Q. Judge. 1474 p. 8^s.

FITCH, H. The Fallacy of Free Land. Denver, Col., C. F. Coleman, Pr. 16 p. 16^s.

— The Light under the Bushel: Womanhood Suffrage. Denver, Col., Coleman & Haigh, Pr. 12 p. 16^s.

LANGLEY, S. P. Secretary of the Smithsonian Institution, Report of, for the Year 1887-88. Washington, Government. 122 p. 8^s.

LOWELL, J. R. Books and Libraries and other Papers. (Riverside Literature Series, No. 39.) Boston and New York, Houghton, Mifflin, & Co. 82 p. 16^s. 15 cents.

MODERN LANGUAGE ASSOCIATION of America, Transactions and Proceedings of the 1887. Vol. III. Baltimore, Mod. Lang. Assoc. 244 p. 8^s.

RUNKLE, J. D. Elements of Plane Analytic Geometry. Boston, Ginn. 344 p. 12^s. \$2.

SANITARY VOLUNTEER, The, Vol. I. No. 1. Concord, N. H., L. A. Watson. 24 p. 8^s. 50 cents per year.

U. S. BUREAU OF NAVIGATION, Report of the Chief of the, to the Secretary of the Navy, 1887. Washington, Government. 87 p. 8^s.

— Same, 1888. Washington, Government. 106 p. 8^s.

U. S. Commissioner of Internal Revenue, Report of the, for the Fiscal Year ended June 30, 1888. Washington, Government. 223 p. 8^s.

U. S. NAVAL OBSERVATORY, Report of the Superintendent of the, for the Year ending June 30, 1888. Washington, Government. 24 p. 8^s.

Schools.

CONNECTICUT, NEW HAVEN,
MRS. CADY'S SCHOOL FOR YOUNG LADIES.
Prepares for Smith and Wellesley, and admits to Vassar by Certificate. Circulars. Early application necessary.

VERMONT, BURLINGTON.
VERMONT EPISCOPAL INSTITUTE. Boarding School for Boys. Prepares for College or Business. Military drill. Terms moderate. Fifty-seventh half-year opens September 1, 1888. Send for catalogue.
H. H. ROSS, A.M., Principal.

Theatres.

BROADWAY THEATRE. Corner 41st St. Manager... MR. FRANK W. SANGER.
LITTLE LORD FAUNTLEROY.
Evenings at 8. Mat. Sat. at 2.

LYCEUM THEATRE. 4th Av. and 23d St. Daniel Frohman, Manager.
SWEET LAVENDER.

MADISON SQUARE THEATRE. Mr. A. M. Palmer, Manager. Sole Manager. CAPTAIN SWIFT.

PALMER'S THEATRE. B'way and 30th St. MRS. POTTER. Scale of prices, \$2, \$1.50, \$1, and 50 cents.

A Harvard graduate desires engagement as teacher of higher English branches, such as composition, rhetoric, literature, history, political economy, mathematics.

Address J. B. H., SCIENCE office.

Meteorological Exhibition.

An exhibition of meteorological instruments, charts and photographs will be held at the Mass. Institute of Technology, Boston, for several days, beginning Tuesday, Jan. 15th. Besides ordinary meteorological instruments, the collection will include barographs, thermographs and other self-registering apparatus, and also appliances for the observation of atmospheric electricity. The exhibition is given under the auspices of the New England Meteorological Society, which will hold a public meeting for discussion of the uses and merits of the different instruments on the afternoon of the 15th.

MAGIC Stereopticons and the Best Views for Public Church, Home, and LANTERNS Scientific Exhibitions. Best apparatus, new views. Largest stock. Reduced prices. 24 Years' Practical Experience. Illus. Catalogue Free.

Geo. H. Pierce, 136 S. Eleventh St., Philadelphia, Pa

JAHRESBERICHT DER CHEMIE [Fittica] 1877-1885 inclusive; 12 volumes in cloth, half goat. For sale at cost. Also Register zu den Berichten für 1867 bis 1876. Address: Scientific Library, Smith College, Northampton, Massachusetts.

SCIENCE CLUBBING RATES.

	Year's Subscription.	With Science.	With Cross.
10% DISCOUNT.			
We will allow the above discount to any subscriber to <i>Science of the Swiss Cross</i> who will send us an order for periodicals exceeding \$10, counting each at its full price.			
American Agriculturist.....	\$ 1.50	\$ 4.30	\$ 2.50
American Analyst.....	1.00	4.25	2.25
American Architect and Building			
Imperial edition.....	10.00	12.80	11.00
Gelatine.....	7.00	9.80	8.00
Regular.....	6.00	8.50	7.00
American Garden.....	4.00	7.50	5.50
American Journal of Philology.....	3.00	6.25	4.25
American Machinist.....	2.50	5.30	4.00
American Magazine.....	3.00	5.50	4.50
American Naturalist.....	4.00	7.00	5.50
Andover Review.....	4.00	6.80	5.00
Atlantic.....	4.00	6.80	5.00
Babyhood.....	1.50	4.30	2.50
Babylonia.....	1.50	3.75	2.25
Bradstreet's.....	5.00	7.80	6.00
Brain.....	3.50	6.30	4.50
Building (weekly).....	6.00	8.80	7.00
Century.....	4.00	7.00	5.50
Century Magazine.....	4.00	6.80	5.00
Chautauquan, The.....	1.50	4.30	2.50
Christian Union, The.....	3.00	5.60	4.00
Christian Science, Illustrated.....	4.00	7.50	5.50
Cosmopolitan, The.....	2.00	4.80	3.00
Critic.....	3.00	5.80	4.00
Doctor.....	2.00	4.80	3.00
Electric Magazine.....	5.00	7.80	6.00
Edinburgh Review.....	4.00	6.80	5.00
Electrical World.....	3.00	5.80	4.00
Electrician and Electrical Engineer.....	3.00	5.80	4.00
Electrical Review.....	3.00	5.80	4.00
Engineering and Mining Journal.....	4.00	7.00	5.50
English Illustrated Magazine.....	1.75	4.55	2.75
Family Story Paper (N.Y.).....	3.00	5.80	4.00
Forest and Stream.....	4.00	6.80	5.00
Forum, The.....	4.00	7.00	5.50
Godey's Lady's Book.....	2.00	4.80	3.00
Harper's Bazar.....	4.00	6.80	5.00
Harper's Magazine.....	4.00	6.80	5.00
Harper's Weekly, Illustrated.....	4.00	6.80	5.00
Harper's Young People.....	2.00	4.80	3.00
Health and Home.....	1.00	4.25	2.25
Herald of Health.....	1.00	4.25	2.25
Illustrated London.....	4.00	6.80	5.00
Independent, The.....	3.00	5.80	4.00
Inter Ocean, The.....	1.00	4.25	2.25
Iron Age (weekly).....	4.00	7.00	5.50
Journal of Philology (Eng.).....	2.50	5.30	3.50
Journal of Speculative Philosophy (begins with Jan. No.).....	3.00	5.80	4.00
Judge.....	4.00	6.80	5.00
La Revue.....	4.00	6.80	5.00
Life.....	5.00	7.80	6.00
Lippincott's Magazine.....	3.00	5.80	4.00
Littell's Living Age.....	8.00	10.80	9.00
Little Men and Women.....	4.00	6.80	5.00
London Quarterly.....	4.00	6.80	5.00
Macmillan's Magazine.....	3.00	5.80	4.00
Magazine of American History.....	5.00	7.80	6.00
Medical and Surgical Journal.....	4.00	6.80	5.00
Mechanical Engineer.....	2.00	4.80	3.00
Metal Worker.....	1.00	4.25	2.25
Microscope, The.....	1.00	4.25	2.25
Nature.....	6.00	8.80	7.00
New Princeton Review.....	3.00	5.80	4.00
North American Review.....	5.00	7.80	6.00
Outing.....	3.00	5.80	4.00
Panorama Monthly.....	4.00	6.80	5.00
Paper.....	4.00	6.80	5.00
Popular Science Quarterly.....	3.00	5.80	4.00
Popular Science Monthly.....	5.00	7.80	6.00
Popular Science News.....	1.00	4.25	2.25
Portfolio, The.....	3.00	5.80	4.00
Practitioner.....	3.50	6.30	4.50
Public Opinion.....	3.00	5.80	4.00
Puck.....	5.00	7.80	6.00
Puck (German).....	4.00	7.00	5.00
Quarterly Review (London).....	4.00	6.80	5.00
Queries.....	1.00	4.25	2.25
Rural New-Yorker.....	2.00	4.80	3.00
St. Nicholas.....	1.00	3.50	2.50
School Journal.....	2.50	5.30	3.50
Scientific American.....	3.00	5.80	4.00
Supplement.....	5.00	7.80	6.00
St. Architect and Building.....	1.00	3.50	2.50
Scribner's Magazine.....	3.00	5.80	4.00
Southern Cultivator.....	1.50	4.30	2.50
Springfield Republican (weekly).....	1.00	4.25	2.25
Primary School Times.....	2.00	4.80	3.00
Teachers' Institute.....	1.25	4.25	2.25
Texas Sittings.....	4.00	6.80	5.00
Treasure-Trove.....	1.00	4.25	2.25
Truth Seeker, The.....	3.00	5.80	4.00
Wide Awake.....	2.00	5.20	3.50
Young Folks' Journal.....	1.00	4.25	2.25

EVENING SILKS.

We have just received several cases of Novelty Silks for evening wear, specially intended for the approaching season. The ground colors are white and various delicate gaslight shades, and are broadened in Silver and Gold in very unique designs.

Orders by mail will receive careful and prompt attention.

JAMES McCREERY & CO.

BROADWAY AND ELEVENTH ST., NEW YORK CITY.

SCHOOLS AND COLLEGES will have a special advantage by ordering their furniture apparatus and supplies from C. PARDO & CO., 31 East 17th St., New York.



JOHN HASTINGS = Pres't. A-R-HART = Gen. Manager. J-O-S=TRIPP = V. Pres't.

ENGRAVING FOR ALL ILLUSTRATIVE AND ADVERTISING PURPOSES

67-71 PARK PLACE, NEW YORK.

N. D. C. HODGES, 47 Lafayette Place, New York.

16 PAGES. THREE 16 PAGES.

Hundred Thousand new subscribers for The Family Journal and Ladies' Companion wanted. It is the most interesting and instructive paper ever issued. Subscribers will receive during the coming twelve

MONTHS

novels written by American Authors, complete in each three numbers. The story of popular works of fiction will be retold by a novel reader, the most interesting and unique feature ever introduced in any publication, giving the substance of popular and standard books by famous writers in a space easily read by the busiest people. We have engaged

FOR

this work a widely known and popular writer. Comments on Current Events, Fashions, New and Original Ideas and Designs for Ladies' Fancy Work and Household Decoration, Letters from Correspondents and their Answers. The colleges and seminaries of the United States will be treated one each month in an illustrated article, showing the particular advantage of each, cost of attendance, etc. Invaluable to parents having some or daughters whom they desire should receive the advantages of a higher education than the ordinary school affords. Articles on Painting and Drawing, giving home instruction by a well-known artist. A trial subscription of this elegant paper will be sent to any address, three months, for

TEN CENTS.

Liberal pay for literary work adapted to our columns, and for new and original drawings, designs and ideas on any subject which we can use.

From the List the most complete in the world. We offer inducements to club raisers and agents approached by no other publishing house. The celebrated Gilbert's Cut Waist Linings, which we send post paid to any one sending us two yearly subscribers at 40 cents each, and at 75 cents.

12 Sent to any address, postpaid one year, 50 cents; six months, 25 cents, and three months' trial subscription for only 10 cents.

TRY IT! TRY IT! TRY IT!

and you will become a permanent reader. Address:

John L. Douglass, Publisher, 322 Broadway, N. Y.

IMPROVED OIL LIGHT MAGIC LANTERNS.

Also Lime and Electric Light Apparatus, and mechanical, plain, and fine colored views.

J. B. COLT & CO., Manufacturers, No. 16 BEEKMAN STREET, NEW YORK.

DELAY IS DANGEROUS.

We call attention to the new form of Accident (indemnity) Insurance policies, which are written by the Merchants' Casualty Insurance Association, 27 Park Row, New York City. John S. Purdy, Secretary. These policies cover weekly allowances of from \$10 to \$25, according to occupation, at a cost of only \$6 a year exclusive of the cost to join, which is \$5 payable once only. The public, as a rule, carry life insurance, and the ordinary accident policies issued by companies, paying a sum in case of death, is not so desirable as one of these indemnity policies in case of accidents, which are so plentiful in this fast age with its railroad horrors, fast driving, electric wires and other countless forms of danger to which the public is constantly exposed. The fact of the Association having no unpaid claims, and its having just passed an examination by the Insurance Department of New York State, shows that the management is liberal with its policy-holders and conservative in its action. The Association also desires to secure energetic Agents in every village and town, to whom territory and favorable terms will be given.

QUEEN & CO. MANUFACTURERS AND IMPORTERS 524 CHESTNUT ST. PHILADELPHIA. MAGIC LANTERNS SCIOPTICONS STEREOPTICONS PROJECTING APPARATUS FOR SCHOOLS COLLEGES AND PUBLIC ENTERTAINMENTS. SEND FOR CATALOGUE.

REMINGTON



MISS M. E. ORR.

Standard Typewriter



REMINGTON.

WON GOLD MEDAL. AND SILVER MEDAL

FOR CHAMPIONSHIP OF THE WORLD,

At Toronto, August 13, 1888.

OFFICIAL REPORT.

"On General Writing - law, evidence, and commercial matter - Miss M. E. Orr won the Gold Medal for the Championship of the World. Mr. McGurran won the Silver Medal in the same class."

*Both Miss Orr and Mr. McGurran used Remington Typewriter.

WYCKOFF, SEAMANS & BENEDICT, 327 Broadway, N. Y.

W. H. WALMSLEY & CO. SUCCESSORS TO R. & J. BECK,

1016 Chestnut Street Phila

Microscopes and all Accessories and Apparatus. Photographic and Photo-Micrographic Apparatus and Outfits.

Spectacles, Eye Glasses, Opera and Marine Glasses, etc.

Illustrated Price List mailed free to any address. Mention SCIENCE in corresponding with us.



AMATEUR PHOTOGRAPHERS' PATENT NOVEL ANTHONY'S FAIRY-AND-DEEP-FOCUS CAMERAS. 251 BROADWAY, N.Y.

THE ECLIPSE

"THE ECLIPSE." COPYING APPARATUS.

One thousand copies in black. No special pen, no special paper, no stencil required. The "Eclipse" reproduces the natural handwriting so exceedingly faithful that in most cases "Eclipse" circulars have been taken for ordinary written letters. Specimens and circulars on application.

FELIX F. DAUS & CO., 69 3/4 Broadway, New York.

THE GREAT AMERICAN TEA COMPANY. GOOD NEWS TO LADIES. Greatest inducements ever offered. Now's your time to get up orders for our celebrated Teas and Coffees, and secure a beautiful Gold Band or Moss Rose China Tea Set, Dinner Set, Gold Band Moss Rose Toilet Set, Watch, Brass Lamp, or Webster's Dictionary. For full particulars address THE GREAT AMERICAN TEA CO., P. O. Box 289, 31 and 33 Vesey St., New York.

CALIGRAPH

MEDAL AWARDED!

GREATEST SPEED ON RECORD!!

126 words per minute, errors excluded.

T. W. Osborne, winner of international contest at Toronto, wrote on the Caligraph Writing Machine 630 words in five minutes, thus gaining for the Caligraph the championship of the world.

30,000 in Daily Use.

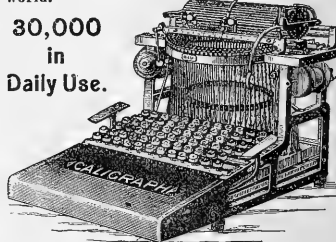

For full and correct account of above test, address THE AMERICAN WRITING MACHINE CO., HARTFORD, CONN. New York Branch, 237 Broadway.

J. GRUNOW,

621 Sixth Avenue, New York. Established 1852.

MAKER OF Microscope Stands, Oil Immersion Objectives and Abbe Condensers for Bacterial and Histological work, of Objectives, Camera Lucida and other accessory apparatus.

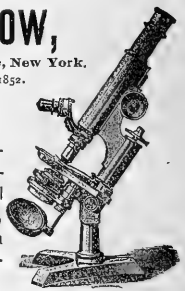

ESTERBROOK'S STEEL PENS.

OF SUPERIOR AND STANDARD QUALITY. Leading Nos.: 048, 14, 130, 135, 239, 333 For Sale by all Stationers. THE ESTERBROOK STEEL PEN CO., Works: Camden, N. J. 26 John St., New York.

ESTABLISHED 1859. H. A. DREW, Commercial Printer, 5 Clinton Place, near Broadway, New York.

Wedding Orders, Souvenirs, Invitations, Orders of Dance, etc., etc., done in the latest and most elaborate styles, at reasonable prices. All Favors promptly attended to.

BACK NUMBERS and complete sets of leading Magazines. Rates low. AM. MAG. EXCHANGE, Schoharie, N.Y.

Old Magazines, Reviews and Periodicals, H. Williams, 39 MacDougal Street, New York.

SCIENCE

133025
JAN 5 1889
NEW YORK

SEVENTH YEAR.
VOL. XIII. No. 309.

NEW YORK, JANUARY, 4, 1889.

SINGLE COPIES, TEN CENTS.
\$3.50 PER YEAR, IN ADVANCE.

NOW READY:

In Two Volumes, Large 12mo. Price, \$6.00.

THE AMERICAN COMMONWEALTH

BY

JAMES BRYCE, M.P., D.C.L.,

Author of "The Holy Roman Empire."

SELECTED PRESS NOTICES.

"A work unique in scope, spirit, and knowledge. There is nothing like it anywhere, extant,—nothing that approaches it. . . . Every thoughtful American will read it."—*New York Times*.

"We have here a storehouse of political information regarding America such as no other writer, American or other, has ever provided in one work."—*New York Tribune*.

"We have no hesitation in placing this book at the head of those which pretend to treat of our form of government in theory and in its practical working."—*N. Y. Evening Post*.

"One must look far and wide, through dozens of volumes, for anything like the information and the intelligent criticism which are here to be found."—*Boston Herald*.

"With very much more than the ordinary emphasis must it be said that 'The American Commonwealth' deserves a very careful reading among the 60,000,000 of Americans whom it concerns."—*Morning Journal*.

"The event of the year in the literary world takes place to-day in the publication by Messrs. Macmillan of Mr. Bryce's monumental work on 'The American Commonwealth.'"—*Fall Mall Gazette*.

"Prof. Bryce himself is so well known in literature and in public life that any book from him is sure to be seriously discussed. Especially is this true of an elaborate work on American institutions."—*G. W. S., in New York Tribune*.

"This splendid work on the institutions of the United States will prove the great work of the year for all thoughtful readers in this country."—*Washington Capital*.

MACMILLAN & CO., 112 Fourth Avenue, New York.

ELECTRICAL TESTING BUREAU,

Johns Hopkins University, Baltimore, Md.
Resistance Coils and Boxes Compared.
Am meters and Volt meters calibrated.
Condensers standardized.
Primary and Secondary Batteries Tested.
Efficiency of Dynamos and Motors Determined.
Insulation of Cables and Wires Tested.
Etc., Etc.
Circulars describing Methods Used, Prices, Etc., sent on Application.
Address as above.

Insurance.

DELAY IS DANGEROUS.

We call attention to the new form of Accident (indemnity) Insurance policies, which are written by the Merchant's Casualty Insurance Association, 21 Park Row, New York City, John S. Purdy, Secretary. These policies cover weekly allowances of from \$10 to \$25, according to occupation, at a cost of only \$6 a year exclusive of the cost to join, which is \$5 payable once only. The public, as a rule, carry life insurance, and the ordinary accident policies issued by companies, paying a sum in case of death, is not so desirable as one of these indemnity policies in case of accidents, which are so plentiful in this fast age with its railroad horrors, fast driving, electric wires and other countless forms of danger to which the public is constantly exposed. The fact of the Association having no unpaid claims, and its having just passed an examination by the Insurance Department of New York State, shows that the management is liberal with its policy-holders and conservative in its action. The Association also desires to secure energetic Agents in every village and town, to whom territory and favorable terms will be given.

R. ELLIS & CO.

BUSINESS, HOTEL AND PATENT BROKERS,

AUCTIONEERS, ETC.

No. 23 PARK ROW,

Rooms 14 and 15.

New York.

CLIENTS Advised free of charge.

SCIENTIFIC BOOKS.

Catalogue of Books relating to Civil, Mechanical, Electrical, and Mine Engineering, and Manufacturing Industries sent free to any address.

E. & F. N. SPON,

12 Cortlandt Street, New York.

CONNECTICUT, NEW HAVEN.

MRS. CADY'S SCHOOL FOR YOUNG LADIES.
Prepares for Smith and Wellesley, and admits to Vassar by Certificate. Circulars. Early application necessary.

VERMONT, BURLINGTON.

VERMONT EPISCOPAL INSTITUTE. Boarding School for Boys. Prepares for College or Business. Military drill. Terms moderate. Fifty-seventh half-year opens September 1, 1888. Send for catalogue. H. H. ROSS, A.M., Principal.

MAGIC lanterns, repletions and the Best Views of Public, Church, Home, and Scientific Exhibitions. Best apparatus, new views. Largest stock. Reduced prices. 24 Years' Practical Experience. Illus. Catalogue Free.

GEO. H. PIERCE,

136 S. Eleventh St., Philadelphia, Pa

BACK NUMBERS and complete sets of leading Magazines. Rates low. AM. MAG. EXCHANGE, Schoharie, N.Y.

SCHOOLS AND COLLEGES

will have a positive advantage by ordering their furniture, apparatus and supplies from C. PARDO & CO., 31 East 17th St., New York.

A TEMPORARY BINDER

for *Science* is now ready, and will be mailed postpaid on receipt of price.



Cloth - - - 50 cents.
Half Morocco - - 75 cents.

This binder is strong, durable and elegant, has gilt side-title, and allows the opening of the pages perfectly flat. Any number can be taken out or replaced without disturbing the others, and the papers are not mutilated for subsequent permanent binding. Filled in this binder, *Science* is always convenient for reference.

N. D. C. HODGES,
47 Lafayette Place, New York.

Readers of *Science*

Corresponding or in favor of mentioning, will confer the paper.

GUARANTY INVESTMENT COMPANY

CAPITAL \$250,000.

Offices: Atchison, Kan. 191 Broadway, New York. 222 Walnut St., Phila.

Hon. ALBERT H. HORTON (Chief Justice, Kansas Supreme Court), Topeka, Kan., Pres't.

7% Guaranteed Farm Mortgages 7%

The Guarantee Investment Company makes loans upon fertile farms in the choicest portions of Kansas and Nebraska and has adopted the policy of sending a Committee of its Investors each year to examine its loans and methods of business.

The Committee this year consisted of PROF. A. H. BERLIN, Principal of the High School Montrose, Pa., and MAJ. THEODORE L. POOLE, Ex-U. S. Pension Agent, Syracuse, N. Y. Both of these gentlemen are persons of the highest character and have the confidence of the Communities in which they reside.

The Committee has recently returned and has made a very interesting Report upon the general development of Kansas and Nebraska as well as the business of the Company. The Company will be glad to send this Report to any address.

The following names are taken from the long list of Investors in our Mortgages:

(See if Some Friend of Yours is not in the List.)

William A. Cauldwell, 50 Liberty St., N.Y.
Palmer Cox, 658 Broadway, N.Y.
Rev. Jos. H. Eyllance, D.D., 11 Livingston Place, N.Y.
Rev. Grady E. Backus, D.D., 370 West 28th St., N.Y.
Rev. R. M. Sommerville, 126 West 43d St., N.Y.
Dr. Robert A. Murray, 231 West 23d St., N.Y.
Dr. James P. Tuttle, 126 West 43d St., N.Y.
H. Edwards Kowland, 212 Fulton St., N.Y.
Irving H. Tift, Esq., 271 Broadway, N.Y.
Prof. D. G. Eaton, 55 Pineapple St., Brooklyn, N.Y.
Dr. F. W. Thwing, 156 St. Marks Ave., Brooklyn, N.Y.
Dr. C. C. Miles, Greenport, N.Y.
John V. N. Bergen, Port Jefferson, N.Y.
Benj. W. Stilwell, Yonkers, N.Y.

R. C. Coleman, Goshen, N.Y.
Mrs. Samuel Carlisle, Newburg, N.Y.
Dr. C. C. Bartholomew, Ogdensburg, N.Y.
Rev. Nelson Millard, D.D., Rochester, N.Y.
Rev. Horace G. Hinsdale, D.D., Princeton, N.J.
Dr. Charles M. Howe, Passaic, N.J.
George A. Skinner, 5 Railroad Place, Newark, N.J.
Dr. Edwin M. Howe, 85 Halsey St., Newark, N.J.
Dr. H. G. Buckingham, Clayton, N.J.
Dr. Martin Cole, Jr., Hainesville, N.J.
Mortgage Trust Co. of Pa., Philadelphia, Pa.
Miss Mary Miller, 1230 Spruce St., Philadelphia, Pa.
Henry D. Biddle, 312½ Walnut St., Philadelphia, Pa.

Dr. Calvin C. Halsey, Montrose, Pa.
Rev. William Baldwin, Great Bend, Pa.
Gen. William Lilly, Mauch Chunk, Pa.
Second Nat. Bank, Mauch Chunk, Pa.
Enos E. Thatcher, West Chester, Pa.
Mrs. Townsend Poore, Scranton, Pa.
Rev. Burdett Hart, D.D., New Haven, Conn.
Dr. Frank H. Wheeler, New Haven, Conn.
Charles R. Christy, Stamford, Conn.
Mrs. Catharine P. Fuller, Woodmont, Conn.
Miss Jessie Henderson, Lenox, Mass.
Dr. M. J. Halloran, Worcester, Mass.
Albert Walker, Bennington, Vt.

Address for Report and Monthly Bulletin

HENRY A. RILEY, General Eastern Manager, 191 Broadway, N.Y.

MAP-MAKING.

All publishers or others desiring to have maps made, either from relief plates or by lithograph, should write to us for estimates before placing their orders elsewhere. Any work entrusted to us will be carefully made under the supervision of our geographical editor, Dr. Franz Boas.

N. D. C. HODGES,

Publisher of *Science*,
47 Lafayette Place,
New York.

A NEW MAGAZINE—THE SWISS CROSS
Devoted to spreading a love of Nature among the people. Edited by HARLAN H. BALDWIN, President of the Agassiz Association, and succeeding St. Nicholas as the official magazine of that body. \$1.50 a year. Sample copy 10 cents, or 25 cents for trial subscription for 3 months.
N. D. C. HODGES, PUBLISHER.
Mention this paper. 47 Lafayette Place, New York.

Readers of *Science*
Users, will confer, or visiting with Advertising the paper, great favor by mentioning this paper.

Paillard's MUSIC BOXES

ARE THE BEST.

They play the best selections from all the Standard and Light Operas, Dances, Waltzes, Ballads, Hymns, etc.
Arranged in sets to suit every variety of taste. The largest and most varied stock ever shown in this country. A rare musical treat to all who can visit our warehouses.

M. J. PAILLARD & CO.,
686 Broadway, New York.
Factory, St. Croix, Switzerland.

KNABE PIANOFORTES.

UNEQUALLED IN
Tone, Touch, Workmanship and Durability.
WILLIAM KNABE & CO.
NEW YORK: No. 112 Fifth Ave., above 16th St.
BALTIMORE: Nos. 22 and 24 E. Baltimore St.
WASHINGTON: No. 817 Market Space, Penn. Av., near 9th St.

Whitall's Planispheres locate and name all the Planets, Stars, and Constellations visible at any given minute of time. Every person should possess a set, and obtain useful and interesting knowledge. Heliotellus, Geographical Astronomical Instruments for Schools, private, public, and kindergarten. Ask your Bookseller and Stationer, or address Wm. T. Cooper, manager, 307 Race St., Philadelphia, Pa.



KIMBALL'S STRAIGHT CUT CIGARETTES.

Unsurpassed in quality.
Used by people of refined taste.
Highest award at Brussels, 1889.
The finest smoking mixtures are of our manufacture.
Fifteen First Prize Medals.
WM. S. KIMBALL & CO.
Rochester, N.Y.

Scott's EMULSION
OR Pure Cod-Liver Oil AND HYPOPHOSPHITES
ALMOST AS PALATABLE AS MILK.
So disguised that the most delicate stomach can take it.
Remarkable as a FLESH PRODUCER. Persons gain rapidly while taking it.

SCOTT'S EMULSION
Is acknowledged by Physicians to be the FINEST and BEST preparation of this class for the relief of CONSUMPTION, SCROFULA, GENERAL DEBILITY, WASTING DISEASES OF CHILDREN, and CHRONIC COUGHS.
ALL DRUGGISTS. Scott & Bowne, New York.

SCIENCE

AN ILLUSTRATED JOURNAL PUBLISHED WEEKLY.

Vérité sans peur.

NEW YORK: N. D. C. HODGES.

FRIDAY, JANUARY 4, 1889.

ELECTRIC LIGHTING.—A MODEL CENTRAL STATION.

EXPERIENCE has shown that to attain the best commercial results in electric lighting, the final expression of which comes out in

station, the reduced plan and elevations herewith, of a simple and efficient station, will be found of interest. The station is that of the East End Electric Light Company, at East Liberty, Penn., operating the Westinghouse alternate-current system of distribution. The service from this station covers a very extended area, comprising the business portion of the city, which lies within an average distance of half a mile from the station, ramifying through an extended series of residence streets of the better class, and carrying

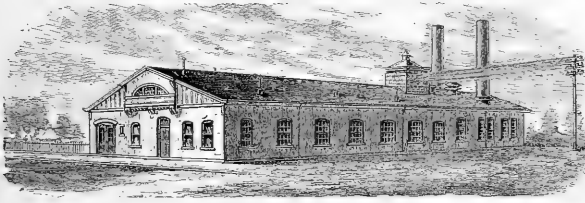

WESTINGHOUSE ELECTRIC-LIGHT STATION AT EAST LIBERTY, PENN.

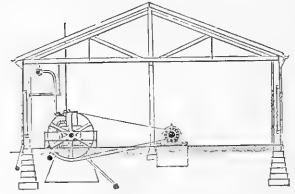

END-ELEVATION.

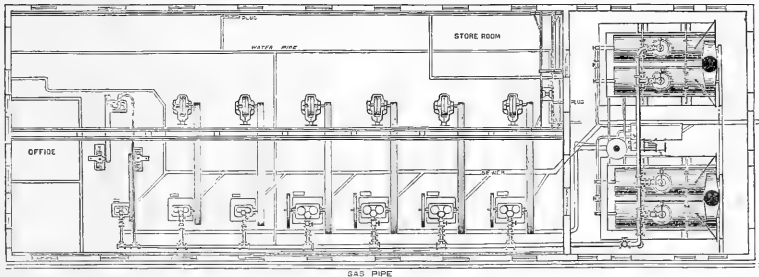
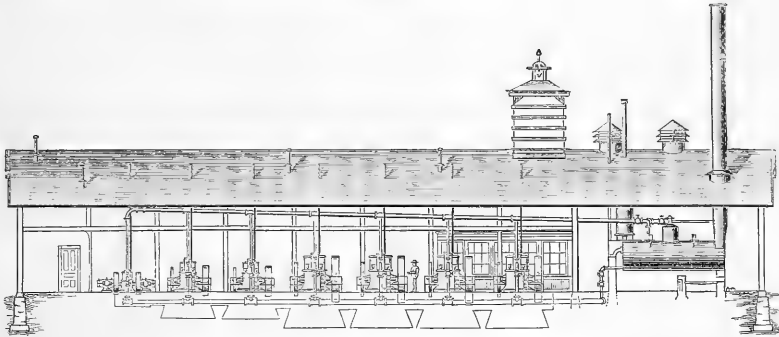

PLAN AND SIDE-ELEVATION OF WESTINGHOUSE ELECTRIC-LIGHT STATION AT EAST LIBERTY, PENN.

dividends, too much care and knowledge cannot be brought to bear upon the steam and electrical engineering involved in the construction of the plant, from the foundations of the building, to the lamp wired on the premises of the consumer. The conditions, however, are found so varied in different localities that it is manifestly impossible to establish any fixed rules. As an illustration, however, which seems to contain the essential ideas of a well-considered

one special line out as far as the distant suburb of Swissvale, the last lamp being at a distance of four miles and a quarter from the dynamo.

The arrangement of the station is clearly indicated. It is a substantial but inexpensive one-story building of brick, containing the offices of the company and the storeroom for material, in addition to the dynamo and boiler room. The plant at present has an ag-

gregate capacity of about 8,000 lamps. Dynamos and engines are on the same floor, every part of which is constantly under the eye of a single attendant. Both engines and dynamos stand on brick foundations, the floor itself being of cement. Each engine is belted direct to its dynamo, no power being wasted in transmission; and the subdivision of power enables the wide fluctuations of load to be met by stopping and starting any engine and dynamo as needed, thus operating the whole station under the highest possible economical conditions at any moment. The steam-pipe is brought along the engine-room overhead, and the engines exhaust into a main laid in a covered trench underneath the floor, every part being accessible. All drips and overflows are run into a sewer. Two exciting dynamos are provided, as shown on the left of the dynamo-room, each adequate to supply current to the fields of all the alternating dynamos of the station, and each driven independently by its own engine. But one engine and exciter is therefore run at any time, the other standing ready as a relay in emergency. Moreover, the position of the engines and exciters is such that by changing a belt either engine can drive either exciter, and thus the chance of possible stoppage is reduced fourfold. The Westinghouse Company regard this latter arrangement as representing the best possible engineering, and strongly urge it upon every station of any considerable magnitude. Two overhead travelling-cranes traverse the whole length of the building over the engines and dynamos.

In a station so arranged, the labor is reduced to a minimum. With natural gas, of course, but one fireman is required; firing with coal, two firemen will be on duty in the first run of the evening, and one in the second run. But one attendant is required in the dynamo-room at any time, the lightness of his duties permitting him to give all necessary attention to the engines, dynamos, exciters, and switch-board. It is obvious that this general plan can be advantageously followed in most instances.

COAL-MINING MACHINES OPERATED BY ELECTRICITY.

THERE has probably been no greater advance in the mining-field effected during the past decade than the general introduction of electricity for power and lighting purposes.

The advantage of using electricity, its simplicity, compactness, safety, cleanliness, and reliability over the use of steam for power, were early recognized by mining engineers, and electricity is now generally regarded as the most convenient agent at the miner's disposal for transmitting his power into the interior of the mine.

One of the newest and latest applications of electric power to mining-work can be seen daily in operation at Mr. T. C. Heimes's "Drane Colliery," near Osceola, Clearfield County, Penn. Here a most interesting application of motors for mining-work has been devised by Mr. F. M. Lechner for operating a coal-cutter by electricity.

Mr. Lechner is well known as being not only the first inventor of coal-cutting machinery, but also the first to operate compressed air in mines for this purpose. His long practice and experience in the coal-mining field have made him familiar with all the difficulties attending the use of machinery in mining-work, and, ever since electric power has been in use for industrial purposes, he has made a study of the problems in adapting electric power to this work.

It soon became evident to Mr. Lechner that the best results could only be obtained by operating the motor and cutter apart, as otherwise the size and weight of the cutter with the motor mounted upon it would prevent its easy transportation in the mine.

In order to do this, the following arrangement has been adopted in the mine before mentioned, and has proved very successful. The motor, which is a 10 horse-power of the Sprague type, is mounted upon a truck running upon rails, so that it can be very easily handled and hauled from one position to another, as occasion requires. The entire weight of the motor is less than 1,000 pounds.

The cutter operated by the motor, which in this case is the "New Lechner," is set in position in the room to be cleared, and is connected with the motor by a five-eighths inch rope belt, running in V-shaped grooved sheaves, one being on the motor, and the other on the cutter.

This connection is long enough to allow the motor to be operated 30 feet away from the cutter, and the motor has been set in a position in this mine 1,600 feet away from the dynamo. The motor is held in position by guys at the point of use.

By means of screw-jacks that can be easily adjusted to any height, with loose sheaves upon them, the cutter can be operated at any angle from the motor; and the connection is made taut by moving the truck upon which the motor rests, and securing it in the right position by guys.

All mining engineers are familiar with the difficulty attending the working of the cutters in the limited space generally allotted them in mines, and know how essential it is to have every machine divested of every pound of surplus weight. They also know what care must be exercised in moving it with great iron crowbars, to prevent injury to the more delicate parts of the engines; and, however careful, how frequent it is that connecting rods and other parts are so impaired that the machine has to be sent to the shop; then how the rugged action of the engines shakes every thing loose on the machine, however firmly they may appear to be adjusted. All this is removed by the absence of the engines, the machine running as smoothly as a buzz-saw, and, as a consequence, cutting with the same facility. By this plan, three machines can be operated by one motor; for, when one room is cut, the motor can at once be hauled to another room, where a machine is in readiness and position, cut that room, and pass to a third while the coal is being removed from the first two, and the cutters being again placed in position.

It was found, upon a preliminary trial of this apparatus at the Osceola Mines, that by its use two men are able to excavate 100 tons in 10 hours, and that they can move the cutter as often as desired without any auxiliary aid.

The efficiency of both dynamo and motor is over 90 per cent; so that, allowing 10 per cent drop on the line, nearly 73 per cent of the power delivered to the dynamo-pulley can be depended upon at the motor for work.

It has been estimated that the cost of equipping a mine for the purpose of operating machinery with electricity is only about one-half the cost of equipping it with compressed air, and the price of maintenance shows about the same proportion of saving.

HEALTH MATTERS.

The Germ Theory in Consumption.

"WHAT Changes has the Acceptance of the Germ Theory made in Measures for the Prevention and Treatment of Consumption?" is the title of an essay by Dr. Charles V. Chapin of Providence, to whom was awarded a premium of two hundred dollars by the trustees of the Fisk Fund. In this essay Dr. Chapin has given an admirable *résumé* of all that has been written about consumption from the time of Hippocrates to the present day. After a careful examination of the literature of the subject, he thinks that we are justified in the conclusion that the acceptance of the germ theory has made no direct or important addition either to the hygiene or medicinal treatment of consumption. He thinks, however, that it should have great influence. It tells us plainly what we ought to do. We simply do not obey its behests. The germ theory—now no longer a theory in the case of tubercular consumption—tells us that we have to do with a contagious disease. Now, there is no theoretical reason why a purely contagious disease like tuberculosis cannot be exterminated. If we can prevent the spread of contagion at all, we can prevent it entirely. The enormous value of preventive measures, isolation, disinfection, and quarantine, is well illustrated in the history of cholera, typhus-fever, and yellow-fever in the United States. By keeping out the virus of these diseases, or destroying it when it had gained access to our shores, we have for a number of years been remarkably free from these diseases, and it is certain that if these precautions had not been taken we should have suffered severely. For obvious reasons the suppression of tuberculosis is not so easy a matter as the suppression of cholera or yellow-fever. Neither is the suppression of scarlet-fever or small-pox as easy. Yet wherever the public have been educated to a correct appreciation of the contagious nature of scarlet-fever, the number of cases has diminished very much. Even in small-pox, with its virulent contagion, it is possible, by means of isolation and

disinfection, to check its spread even among an unvaccinated population, as has been illustrated many times of late in the anti-vaccination city of Leicester, England. We must now put tuberculosis among these diseases, and, though its theoretical suppression is simple, its actual extermination is a very difficult problem. It lies largely with the medical profession how long tubercular disease shall decimate the human race. The physicians are the educators of the people in these matters. When the doctor shall teach that tuberculosis is contagious, the people will believe, and will govern themselves accordingly. In combating contagious diseases the preventive measures taken often give discouraging results. This will be particularly so in tubercular disease. Halfway measures secure less than halfway results, and these alienate the support of those who only indifferently believe in contagion and the importance of precautionary measures. Efficient means of suppression are radical, and bear hard on the individual: they are not complied with, and they produce violent opposition. Yet, difficult as it may be, the medical profession should take aggressive action against this disease. We have no right to wait for the discovery of a specific, or the gradual evolution of a phthisis-proof race. We must take the world as we find it, full of men and women predisposed to tubercular phthisis, and with no idea of its contagious nature. What can we do about it?

1. Teach the people the true nature of tuberculosis; that no one ever has tubercular consumption unless the tubercle bacilli find their way into the lungs.

2. Teach them also, that, even if it finds its way there, it will not grow unless the conditions are right. Teach fathers and mothers how to rear healthy boys and girls. Tell them what to eat and what to wear, to exercise, to breath fresh air. This alone would exterminate phthisis.

3. The contagion must be destroyed. Fortunately in this disease there is no need of isolation. Disinfection is enough. The consumptive patient gives off the poison only in the sputum, or perchance the other excreta, if the disease extend beyond the lungs. The virus is not given off from these while moist. We must therefore disinfect all sputum at once with mercuric bi-chloride. Cloths must be used instead of handkerchiefs, and then burned; or, if the latter are used, they should be often changed, and immediately put in a bi-chloride solution and boiled. Bed-linen should be treated in the same way. Frequent disinfection of the entire person, and fumigation of the apartment, would be safe additions to the preventive measures.

4. Persons who have a marked predisposition to the disease had best not come in close contact with the phthisical. Children should never have tubercular nurses, wet or dry. In the case of consumptives very great attention should be paid to ventilation, and to the alimentation both of the patient and the attendants.

Such measures, if rigidly carried out, would be of enormous service in preventing this disease. But with the increasing prevalence of tuberculosis among domestic animals, something more is imperatively demanded. Active measures should be taken to free the country from animal tuberculosis. The proper authority for dealing with this, as with all other contagious diseases of animals, is the Bureau of Animal Industry of the Department of Agriculture. It is a wasteful method for States to act independently. The powers and expenditure of this bureau should be greatly increased, and it should take active measures against this disease. The exact measures suggested are, —

1. The reporting of all cases of tuberculosis in domestic animals to the proper authority, by both owners and veterinaries, or other persons having a knowledge of the same.

2. The slaughter of all infected animals, and the isolation and slaughter of all exposed to infection. The government should partially indemnify all owners of slaughtered cattle.

3. Thorough disinfection of all buildings occupied by diseased cattle.

4. The confiscation of the flesh and milk and milk products of all tuberculous animals.

Pasteur's Method.

"Pasteur's method hardly attracts any attention now, and seems to be in a fair way to die a natural death." Such is a statement

made by Dr. Charles W. Dulles, in his report on hydrophobia to the Medical Society of the State of Pennsylvania. In support of this statement, he quotes from a report of Dr. Dujardin-Beaumez to the effect that there were nine deaths from hydrophobia in Paris during 1887, which was more than in 1880, 1883, 1884, or 1886. Five of these deaths were of persons less than fifteen years old. In one of the cases the patient was not bitten at all, but was simply licked on an abraded spot. Eight of the patients were bitten by dogs, and one by a cat. Two of the nine patients had been treated by Pasteur; and their death is explained by Dujardin-Beaumez on the ground that his method was not thoroughly carried out. The total number of persons treated by Pasteur was only 306 persons from Paris, bitten by dogs supposed to be rabid, as against about 300 a month one year ago.

These facts, Dr. Dulles thinks, show two very important things. One is, that the application of Pasteur's method has had no effect in reducing the usual mortality from so-called hydrophobia in Paris, which confirms the opinion in regard to its merits which he has repeatedly expressed; the other is, that, in spite of the artificial stimulus furnished by the French reception of Pasteur's method, the number of those who fall into the terror of hydrophobia is diminishing in France, and this leads to the hope that before long France will compare favorably with Germany and America, which have refused to be carried away by the false notions in regard to hydrophobia put forward by one who knows nothing about it but what he has manufactured in his laboratory.

There is a great significance in the fact that disbelief in the theories of Pasteur, which some of his partisans have stigmatized as harsh or unscientific, has been found to go with a singular immunity from the ravages of so-called hydrophobia. This holds true to such an extent that one may safely say that the degree of acceptance of Pasteur's theories in any country will furnish a measure of the number of cases and deaths from hydrophobia. In Germany these theories have never obtained a foothold, and hydrophobia is almost unknown: in America the attempt to import them ended in speedy failure, and here hydrophobia is almost equally unknown.

A detailed account of fifteen fatal cases of hydrophobia is given by the author of the paper. Attention is called by him to the following points, which are brought out in a study of these cases: —

1. *The Effect of Anticipation of Hydrophobia.* — This is said to have been present in seven of the fifteen cases, and may be suspected in more.

2. *The Lack of Evidence of Rabies in the Animal which did the Biting.* — Not one of the animals furnished more than ground for a suspicion that it was rabid. The fact that a fighting dog bites a man who interferes with it, is no evidence that it is rabid, nor is the manifestation of a vicious temper a good evidence of rabies. The same may be said of death in a fit.

3. *The Effect of a Diagnosis of Hydrophobia.* — In ten of the fifteen cases it is stated that the physicians made an early diagnosis of hydrophobia, and presumably they failed to conceal the fact from the patient.

4. *The Effect of applying the Test of the Water.* — This is said to have been done in seven of the fifteen cases, and it was probably done in almost all of them.

5. *The Assertion that Canine Symptoms were Present.* — Five of the patients are said to have whined, or howled, or snapped, or bitten at their attendants.

6. *The Frequency of Forcible Restraint.* — This is said to have been employed in eight of the cases.

7. *The Uselessness of administering Narcotics.* — Powerful narcotics are said to have been used in ten of the cases, and they were probably used in all. Curare is said to have been used in four cases.

In concluding his report, Dr. Dulles says, "I have on several previous occasions declared my belief that hydrophobia is not a specific inoculable disease. I believe this more firmly to-day than ever before. I do not deny that men and women and children sometimes fall into a peculiar state after a dog-bite, and die in due time; but I do deny that this is attributable to any specific virus in the dog's saliva. The same thing has occurred too often from other causes to justify one in charging it to a specific virus when it

allows a dog-bite. And I believe that the rejection of the specific theory will do more to banish hydrophobia from the world than any thing which we have ever heard of.

"The word 'hydrophobia' should be used only to describe a condition, and not a disease, as we use the word 'convulsions;' and it should be remembered that this condition may be present in a great number of diseases, as I tried to show you when you last met in this city, in 1884.

"I firmly and honestly believe, that, if this view of what is called hydrophobia were generally accepted, the disorder would shrink and disappear, as the geni said, in the tales of the 'Arabian Nights,' to have shrunk and disappeared when the right word was spoken; and I call your attention to the fact that hydrophobia is now almost unknown in our own State of Pennsylvania. Not a single case has occurred in our State since we last met, and I cannot but attribute this fact partly to the extent to which your judgment confirms the opinions to which my studies of hydrophobia have led me.

"I do not despair of seeing the belief in hydrophobia follow the belief in witchcraft, which once had the support of Church and State, of the medical profession and the laity, but which now, thank God! torments our fellow-men no more. So long, at least, as Pennsylvania presents the spectacle of freedom from the thraldom of ancient superstitions in regard to hydrophobia, and freedom from its curse, I cannot but think that the former has some causal connection with the latter."

INEBRIATE ASYLUMS.—Dr. T. D. Crothers of Hartford, Conn., in an address on "Inebriate Asylums and their Work," delivered at Toronto, Can., draws the following conclusions as being supported by the latest teachings of science and experience: 1. Inebriate hospitals must take the place of jails and station-houses. Such places are dangerous in their mental and physical surroundings, by intensifying the degeneration, and removing the patient beyond hope of recovery. They are in many cases literal training-stations for mustering in armies of chronic maniacs that never desert or leave the ranks until crushed out forever. 2. Inebriate hospitals should receive the incurable inebriates, and make them self-supporting, and build them up physically and mentally. They would relieve the tax-payer, and relieve society of untold burdens of sorrow and misery. 3. Inebriate hospitals should receive the recent cases, and place them in the highest conditions of enforced health and vigor, and thus return a large number to health and sobriety again. 4. Inebriate hospitals can and should be self-supporting when once established. They should be managed on scientific business principles, like military training-schools. 5. Inebriate hospitals should be built from the money raised by taxes on the sale of spirits, on the principle that every business should be obliged to provide for the accidents which grow out of it. 6. These are the realities which every inebriate hospital is approaching, and which all experience points out as practical and literal in the near future. 7. The inebriate hospitals of to-day are only in the infancy of their work, contending with great opposition and prejudice, misunderstood, condemned, and working against innumerable obstacles. 8. The work of the present inebriate hospitals, notwithstanding all the difficulties and imperfections, has the grandest promise for the future, and encouragement for further effort in this field, along the line of scientific research. 9. Lastly, there is an intense personality in inebriate hospitals to each one of us. They may bring salvation and restoration to some one near and dear. They may be fountains of healing whose influence shall cross and influence our pathway in many ways. 10. Inebriate hospitals and their work is the great new land which only a few settlers have reached. They are calling to us to come up and occupy, and thus help the race on in the great march from the lower to the higher.

THE NATIONAL ELECTRIC LIGHT ASSOCIATION.

THROUGH the efforts of Mr. George F. Porter, of the transportation committee, one and one-third rates were obtained some time ago for all delegates travelling to the coming convention in Chicago, in the territory of the Trunk Line Association. It gives us pleasure to now announce that the same active worker has secured the same

rates from the Central Traffic Association, whose territory covers all that portion of the United States lying west of Pittsburgh (Penn.), Buffalo (N.Y.), and Bellaire (O.), and north of the Ohio River and east of Chicago (Ill.). The method of obtaining the return ticket from the Chicago Convention (Feb. 19, 20, and 21) is extremely simple.

First, Each person must purchase (not more than three days prior to the date of the meeting nor later than three days after the commencement of the meeting) a first-class ticket (either unlimited or limited) to the place of meeting, for which he will pay the regular tariff fare, and upon request the ticket-agent will issue to him a certificate of such purchase properly filled up and signed by said ticket-agent. Second, If through tickets cannot be procured at the starting-point, the person will purchase to the nearest point where such through tickets can be obtained, and there repurchase through to place of meeting, requesting a certificate properly filled out by the agent at the point where repurchase is made. Third, Tickets for the return journey will be sold by the ticket-agents at the place of meeting at one-third the highest limited fare, only to those holding certificates signed by the ticket-agent at point where through ticket to the place of meeting was purchased, and countersigned by the secretary or clerk of the convention, certifying that the holder has been in attendance upon the convention. Fourth, It is absolutely necessary that a certificate be procured, as it indicates that full fare has been paid for the going journey, and that the person is therefore entitled to the excursion fare returning. It will also determine the route *via* which the ticket for return journey should be sold; and *without it no reduction will be made*, as the rule of the association is that "no refund of fare will be made on any account whatever, because of the failure of the parties to obtain certificates." Fifth, Tickets for return journey will be furnished only on certificates procured not more than *three days* before the meeting assembles, nor later than three days after the commencement of the meeting, and will be available for continuous passage only; no stop-over privileges being allowed on tickets sold at less than full fares. Certificates will not be honored unless presented within *three days* after the date of the adjournment of the convention. Sixth, Ticket-agents will be instructed that excursion fares will not be available unless the holders of certificates are properly identified, as above described, by the secretary, on the certificate, which identification includes the statement that one hundred or more persons, who have purchased full-fare tickets for the going passage, and hold properly receipted certificates, have been in attendance at the meeting. The certificates are not transferable, and the signature affixed at the starting-point, compared with the signature to the receipt, will enable the ticket-agent to detect any attempted transfer. This convention will undoubtedly be the largest and most interesting which has ever been held, and will be accompanied by an exhibition of electric light and power apparatus and supplies, which will be in a large hall devoted entirely to this purpose.

Electric light and power men who are not now members of the association would do well to join at once, which they can do by addressing the secretary, Allan V. Garratt, at 16 East 23d Street New York City.

So large a number of the representative manufacturers and dealers in the electric light and power apparatus and supplies have expressed a wish that facilities be afforded them to make a very large exhibit at the coming convention of the National Electric Light Association in Chicago, in February, that the executive committee has decided to secure a large hall, where ample room for each exhibitor may be had. Before the committee can proceed further with the matter, it will be necessary to know how many exhibitors there will be, how many square feet of floor space each will want, how many horse-power in steam, how many horse-power from shafting, and how much current and at what electro-motive force. For the purpose of the committee at present, it will only be necessary to have an approximate idea of what is wanted: therefore any intending exhibitors should apply at once to Mr. B. E. Sunny, chairman executive committee, 148 Michigan Avenue, Chicago, Ill.

GINN & CO. announce that the new edition of Lanman's "Sanskrit Reader" is ready.

THE AGASSIZ ASSOCIATION.¹

THE Agassiz Association, as most of you know, is a union of local societies which have been organized for the study of nature by personal observation.

It is not for the sake of any money you may make out of it that we advocate the study of nature. If it were, our association must change its name; for Louis Agassiz used to say that he had "no time to make money." We urge you to join us in this study for the sake of learning what is true. We honor those who set knowledge above "gold and the crystal," and esteem the price of wisdom "above rubies." There is great pleasure in the mere seeking of truth. There is a delight in all discovery.

Now, nature offers to every one of us new gifts every day. No matter how long a beetle may have been known to others, until you have found it for yourself, it is not old to you. So, too, although the species may be familiar, each new specimen has the charm of novelty.

But besides the pleasure of learning, it has been found that one who studies nature aright greatly improves his powers of attention, discrimination, and reasoning. The right way to study nature is to use your own eyes instead of depending upon printed accounts of what somebody else has seen with his. It is a lazy boy who hires another to do his fishing for him. To depend upon the observation of others will no more increase your mental powers than it would improve your muscular development if a friend should swing Indian clubs for you. To one who tries to get all his knowledge of nature from books, every thing comes at second-hand: nothing comes to him as his own discovery. There is no joy in it, and but little benefit. That is why the Agassiz Association always insists upon "personal observation," which is simply a Latinized way of saying, "using your own eyes to see what you can see."

This statement should make plain the nature of the work expected from the little clubs we are organizing in so many cities and towns. The members are to search and find out what there is of interest within, say, five miles of home.

In order to do this, they will make excursions after flowers, minerals, insects, or whatever they most care about, and perhaps make a map showing just where each sort may be found. Of course, they will find a few books useful to help them learn the names of what they find; they will need a cabinet in which to keep their treasures; and they will be glad to have wise men lecture to them now and then, and explain the things that are too hard to study out for themselves. I cannot see that it would do any great harm even if every town and village in the land should have its natural science club, with a little library and museum, and with wide-awake members ready at any time to give the curious traveller an account of all the interesting objects to be found in an afternoon's walk, and able to show him specimens of each variety, nicely preserved, accurately classified, and neatly labelled. All who have read "St. Nicholas" carefully for a few years past, know that the Agassiz Association has organized societies of this sort very successfully, and that the boys and girls—yes, and their parents and teachers, too—have found much recreation in these clubs, and learned much natural history and natural science as well.

During this very year, and since I last wrote to you about our association, more than a hundred new clubs or "chapters" have been added to our roll; and that means more than a thousand new members. You see, there must be at least four in a chapter, and there may be as many more as are desired. One of our chapters, in New Brunswick, N.J., has more than four hundred members, with about a dozen professors to guide them, and there are microscopes, and stereopticons, and all sorts of instruments to aid them in their studies.

After a number of these little clubs are fairly at work in any large city, or throughout a State, they often wish to become better acquainted with one another, and so the clubs hold joint meetings occasionally, and they call these large united gatherings "assemblies."

These assemblies elect their own officers, and hold regular conventions. One of the largest has been formed this year by combining the various societies in Massachusetts. We had a very suc-

cessful convention in Boston on Decoration Day. This holiday happens to occur within a few days of Agassiz's birthday, which is very pleasant and convenient for us. There was an address from Professor Hyatt of the Boston Society of Natural History, a man deservedly popular with young people; and one from Professor Crosby, who has been conducting for our benefit a very interesting course of lessons in mineralogy, extending over more than a year (for which lessons he furnishes the specimens and necessary instruments). Professor Morse of Salem, the author of an excellent book on the study of zoology, also lectured to us. Professor Morse's son is a member of a very active chapter of the Agassiz Association, so active that it organized a stock company of boys and built a house for their meetings. Dr. Lincoln, who is now helping the members of our Boston Assembly to make a thorough study of all minerals to be found within ten miles of the Boston State House, was also one of our instructors.

Another of our recently formed assemblies is the State Assembly of New Jersey. Rev. L. H. Lighthouse is president of this assembly; and while I write (Aug. 10), he is conducting a well-attended seaside meeting. It is to continue for a week. Every morning the members make an excursion, under the lead of some expert, and may have the choice of botany, entomology, or microscopy. Every afternoon they gather in the large Educational Hall, and examine their "finds," with the assistance of the professor who led them in the morning. Every evening they attend a lecture, usually illustrated by the gas-microscope or by the stereopticon. Professor Austen, the president of the New Brunswick Chapter, has been very helpful in organizing and managing this pleasant seaside assembly.

The Iowa State Assembly is about to hold its fifth annual convention. Iowa conventions are always successful. All the chapters send delegates, who bring to the meeting not only carefully written reports of the work the chapters have done during the year, but also the finest of the specimens collected. The young men, and young women too, give most interesting accounts of their studies, illustrating them with specimens, original drawings, diagrams, and maps. Then there is a dinner, a meeting for the practical demonstration of their methods of work, and one or two excursions. This assembly offers three prizes each year for the best work done in any chapter since the previous convention.

I must not stop to give in detail accounts even of all our large assemblies; still less can I undertake to tell of the individual chapters. Among so many, it would be impossible to select single ones for special praise. Merely by way of illustration, however, I may mention Chapter No. 3, of Frankford, Philadelphia, which, under the lead of John Shallcross and Robert T. Taylor, has maintained itself in full vigor since the first year of our extension beyond Massachusetts, and which was instrumental in founding the Philadelphia Assembly, the first assembly in the association.

The Manhattan Chapter of New York City is a noteworthy illustration of what young people can do without aid. This society has grown from a handful of boys, meeting from house to house, into a club of a hundred young men, renting rooms at No. 103 Lexington Avenue, and exhibiting there a fine collection fairly representing the natural productions of Manhattan Island. This chapter, like all others, is glad to welcome visitors to its rooms.

The largest chapter in Massachusetts is No. 448, of Fitchburg, with a hundred and fifty members. This chapter has published a handsome pamphlet, giving an account of all the flowering plants to be found in the vicinity.

A new sort of club has been devised and put into successful operation during the year. Chapters of this sort are called "corresponding chapters." They are composed of members who do not live in the same town, but are united by their common interest in the same study. The first of these was the Archæological Chapter. Its President is Hilborne T. Cresson of Philadelphia; vice-president, Dr. C. C. Abbott of Trenton, N.J.; secretary, A. H. Leitch of Dayton, O. The members of this club are grown men; and they propose, under the auspices and general direction of the Peabody Museum of Cambridge, to preserve ancient mounds from the spade of the vandal and the speculator, until they can be properly and scientifically explored under competent supervision. Two other corresponding chapters recently added are the Gray Memorial

¹ From St. Nicholas for November, 1888.

Chapter, for the study of botany, and the Isaac Lea Memorial Chapter, for the study of shells.

It is worthy of mention that from the beginning the girls and women have kept equal step with the boys and men, not only in patient and thorough work in field and laboratory, but also in the work of organization and direction. Many ladies are efficient secretaries, curators, or presidents of chapters, and one girl has held with honor the office of president of a State assembly.

We have been asked why we favor the establishment of societies. Why should not the study be carried on by individuals? All true study, it is claimed by these critics, is prosecuted in solitude and silence. Great books are not written by a society of authors; poets do not sing in chorus; artists do not paint in clubs; and the light of scientific discovery has come to the world in little flashes of illumination, which have fallen singly upon the minds of silent and lonely thinkers.

There is much truth in this argument, and there can be no good work done either in or out of any society unless each separate worker acts and thinks for and by himself. Yet there are important advantages which are secured by united effort. Every one who finds any thing that interests him, wants some one to whom he can show it. A pleasure shared is a pleasure doubled. Thus, at the meetings of our clubs, each member has a friendly audience to listen to the results of his private study. Then, too, when several friends join in a society, they are often able to buy more expensive books and instruments than any could afford alone. A library may be had, a microscope bought, a lecturer secured, a room rented, a building erected. Think, too, of the pleasure of these social gatherings, often enlivened by music and song; think of the pleasant excursions, picnics, or field-meetings, and the occasional evening receptions.

Besides, when we bring several of these local clubs into fellowship with one another through correspondence, exchanges, or a convention now and then, the pleasures and benefits are greatly increased, and many things are done which no single chapter could do. Storms can be traced and their courses represented on maps; erratic boulders can be tracked to their ancient homes; the routes of travel of birds and insects can be followed for hundreds of miles, and facts of interest gathered in every department of science.

One of the most important features of the last year's work has been in this direction. Simple blanks have been sent to different chapters, with the request that they be filled out with records of local observation in particular branches. One boy has prepared a set of blanks on which different observers are writing accounts of all the dragon-flies they may see, telling the place where each specimen was found, its name, description, habits, etc.; and other members have prepared similar blanks for records of observations on birds and minerals. In this way distant parts of the country are brought into friendly acquaintance; and boys of Maine and boys of Florida, girls of California and girls of Massachusetts, become interested in learning one another's thoughts, and in giving one another information and assistance.

Perhaps a more definite idea of what our boys and girls find in their rambles may be gained from a list of a few of the topics upon which members have made original notes during the year. From hundreds may be named these: "Two Rare Fossils from Catskill," "Rose-Leaf Galls," "White Blackbirds," "Ivy-Blossoms," "Curious Trees," "Animals that do not Drink," "Do Salmon Eat Birds?" "Complementary Colors," "An Abnormal Cabbage-Leaf," "A Living Barometer," "Rainbow and Sun-Dogs," "Double Adder's-Tongue," "New Jersey Butterflies," "Eggs of the Crayfish," "Colorado Ants," "Floating Pollen," "A Double Stinger," "Frost Pictures," "An Experience with a Heron," "A White Weasel," "A Strange Mouse," "Girls in a Silver-Mine."

In closing this brief report, I wish, in behalf of the Agassiz Association, again to invite all who are in any way interested in the study of nature to join us, either by organizing societies in their own towns, or, if that be impossible, by joining as individuals. All are welcome, from the oldest to the youngest. We have a council of fifty scientists always ready to receive from our members questions about whatever may puzzle them, and these gentlemen are eager to give all the help they can. We are just about to begin a

course of simple observation-lessons in botany, open to all our members. The plan is to send to every one who takes the course a set of perhaps fifty specimens, nicely prepared, with printed instructions on the proper way of so observing them as to see all that can be seen, and for telling in the proper way all that is seen — and nothing more. To all who would like to consider the question of joining the association, we will send, free, papers giving full directions for organizing a club or a chapter, or for joining alone. We will also send, until the supply is exhausted, an excellent wood-engraving of Agassiz, representing him examining a sea-urchin. This picture is printed on one of the papers of information, but is one of the best likenesses of Professor Agassiz in existence. All who are interested may address The Agassiz Association, 50 South Street, Pittsfield, Mass.

HARLAN H. BALLARD.

NOTES AND NEWS.

A REGULAR meeting of the American Physiological Association was held in the rooms of Jefferson Medical College, Philadelphia, on Dec. 29, and at the University of Pennsylvania on Dec. 31. A number of interesting communications were read. Professor Reichert recounted experiments showing that the anterior columns of the spinal cord possessed no irritability of their own, or that the power of excitability was confined to the posterior sensory columns. He also showed that the rate of transmission of a nervous impulse differed under different conditions. Dr. J. W. Warren described some recent experiments showing that a sensory impulse, such as the explosion of a torpedo, re-enforced the knee-jerk, and drew the curve showing the variation of this re-enforcement with the interval between the sensation and the knee-jerk. Dr. Donaldson showed specimens from which it could be seen that the effect of a long electrical stimulation was to decrease the size of the nuclei of ganglion-cells, and that the amount of this shrinkage was roughly proportional to the duration of the stimulation. Professor Martin in one paper gave the determinations of the minimal and maximal temperatures consistent with life that the blood supplied to an isolated heart could undergo, and in another showed that the variation in the amount of carbonic acid given off by a normal frog and one kept in the dark was due to the optical and not the psychic differences of the two states, because a frog deprived of its cerebral hemispheres acts in this respect just like a normal frog. All of these papers led to interesting discussions; and the discussion of Dr. Reichert's paper induced Dr. S. Weir Mitchell to place at the disposal of the society two hundred dollars, to be devoted towards aiding research upon the rate of nervous transmission, especially in man. The society was hospitably entertained, and found much pleasure in visiting the laboratories of the Jefferson College and the University of Pennsylvania. The members of the society were invited to participate in the International Congress of Physiologists to be held in Basle in 1889.

— Professor F. Janssen, in a recent number of the "Revue Scientifique," describes his interesting and arduous expedition to the Mont Blanc, undertaken in October of this year, in order to study the influence of the atmosphere upon the solar spectrum. It has long been a disputed question whether the oxygen lines are due to the solar or terrestrial atmosphere. This question can be solved only by observations on elevated stations, where the influence of the atmosphere of the earth is very small. In order to make the results still more satisfactory, Mr. Janssen selected the month of October, when the amount of vapor present is small. The ascent was very difficult on account of the lateness of the season, snow having covered the slopes of the mountain and the glaciers. Notwithstanding his advanced years, Mr. Janssen persevered, and, with the aid of a number of experienced guides, reached the Grands-Mulets, where the observations were to be made. He was favored by exceptionally clear weather, and on Oct. 14 observed the solar spectrum. The lines and bands of vapor were absent, and the bands of oxygen decreased rapidly with increasing altitude of the sun. At noon they had entirely disappeared. The lines, on the other hand, were still visible, but had become very faint. From these observations it appears that oxygen does not exist in the atmosphere of the sun in such form as to produce the lines which it produces in the form in which it occurs in the earth's atmosphere

—The American Historical Association held its fifth annual session last week, a large number of members being present. The president, William T. Poole, in his opening address, treated principally of the ordinance of 1787 for the North-west Territory, and called attention to the great need of impartial biographies of Gen. George W. Clark, La Salle, Kenton, and Father Hennepin; Gen. James Grant Wilson gave an account of the evolution of the "Cyclopedia of American Biography;" Dr. A. G. Warner read a treatise on town and county government in the United States; Professor McLaughlin of the University of Michigan rendered tribute to the influence of Gen. Cass on the development of the North-west; Professor Knight of the Ohio State University treated of the history of higher education in that section; Professor Allen of the University of Wisconsin presented a paper on the position of the North-west in general history; and Major J. W. Powell presented a language-map for North America, which has been prepared by the Bureau of Ethnology. It represents in graphic form the results of the investigations of many persons who have been engaged on the work for the past fifteen years. He explained the methods adopted in correlating and classifying the aboriginal tongues, and the historical researches that had been prosecuted to determine the pristine homes of the various tribes. He finally gave a characterization of Indian languages. Other papers were read by W. C. Fisher of Cornell; C. N. Morris of Berkeley; G. Brown Goode, assistant secretary of the Smithsonian; F. A. Bancroft, librarian of the State Department; H. C. Lee of Philadelphia; W. W. Henry of Richmond; and Clarence W. Bowen of New York. Officers of the association for the coming year were elected as follows: president, Charles Kendall Adams of Cornell University; vice-president, John Jay of New York; second vice-president, William Wirt Henry of Virginia; secretary, Herbert B. Adams of Johns Hopkins University; treasurer, Clarence Winthrop Bowen of New York. An executive committee, in addition to the above-named officers, were elected as follows: Rutherford B. Hayes, George P. Fisher, and John W. Burgess.

—At a recent meeting of the Royal Meteorological Society, Rev. I. A. Preston gave an interesting summary of phenological observations for 1888. He said that vegetation was generally backward throughout the season. In the south-west of England and south of Ireland plants were earlier than usual, but not elsewhere. In February they were from one to four weeks later, and gradually gained ground till June. In the south of Ireland they were slightly in advance of the average in June and July; in the south-west of England they just reached the average in July, while in Guernsey they were a fortnight later. Fruits generally were a failure, — very few really ripened, — and, from want of sun, were deficient in flavor. Hay-making was unusually late (as much as five weeks). It began in July or August, and was not entirely finished till late in September. Much of it was spoiled or secured in bad condition. Straw was plentiful, and, though the corn was not an average crop, the fine October enabled farmers to secure a better one than could have been expected. Roots were often a failure, and potatoes were much diseased. Capt. D. Wilson Barker read a paper entitled "A Winter's Weather in Massowah," in which he gave the results of four-hourly observations from December, 1887, to February, 1888; the highest shade temperature being 95°, and the lowest 68°.

—The observation of the total eclipse of the sun of Jan. 1, which was visible over a belt stretching from California to Manitoba, was favored by clear weather, and it is probable that results of great value have been obtained. The principal work was done by the Harvard University party at the Lick Observatory, by astronomers at Norman, Professor Swift near Chico, the Chabot Observatory, and people at Cloverdale. Professor Louis Smith was stationed at Nelson, Cal., and telegraphed the following as the result of his observations of the eclipse: "As far as affording opportunity to search for intra-mercurial planets, it was a failure from clouds and haze. All four contacts were well made, the chronometer watch previously set to Lick Observatory time being used. Five very small colorless protuberances were seen, all having pointed apices. Near the point of one was another detached from the sun. Bailey's beads were seen at the second and third contacts, but entirely unlike those seen at Denver in 1878. No chromosphere was visible,

though looked for. Mercury, Venus, Vega, and Alpha Cygni were seen. The corona could not be drawn, but as seen through the telescopes it was not very extensive." At Brandon, Manitoba, observations were made. At 3.15 o'clock, central time, 90° longitude, the first contact was observed. At 3.15.34 the shadow had crept over one-half the disk; at 3.15.47, three-quarters; and the totality occurred at 3.16.09. At the quarter a deep-reddish color was observable at the edge of the sun's disk, projecting from beneath the dark body. Immediately after, a sort of halo was formed around the disk, it is difficult to say whether of a greenish or bluish color. It was red at the outer edge, with the color deepening. At 3.15.34 a vibratory motion was visible around the outside of the sun's disk. At the three-quarter obscurity, jets from the upper right and lower left sides and from the lower left horn of the crescent were visible. The corona was irregular, extending to the left and right, — on the left above and on the right below. The corona was observed and sketched very carefully. This sketch was exhibited to other observers, who recognized the irregular shape it assumed. Above and below, the depth was not nearly so great as to the right and left. To the right the illumination assumed an almost square or block appearance, whereas to the left it was narrowest and more elongated. To the observers' view, the inner corona was distinctly visible immediately after totality on the upper left side. This phenomenon grew fainter for 28 seconds, and then more visible, until immediately before the sun's re-appearance, when it was again distinctly visible. On the bottom right-side corner of the inner corona appeared a luminous gold ring, and it was very beautiful during totality. Another observer used his telescope, and secured corroborative evidence of the above. In fact, so well defined was the corona, that to close and careful observers there was no difficulty in agreement. No streamers or filaments were observed. The time of totality, according to one observer, was 56 seconds, and according to another 57. As the eclipse neared totality, the thermometer fell very perceptibly. In fact, it became intensely cold. The vibratory motion already spoken of was distinctly seen on the walls of St. Matthew's Church close by. Stars could be seen studying the deep blue of the heavens. The corona was small and of a pearly lustre. In two places only several long rays were seen. Fuller reports may be expected at an early date.

—In behalf of the American Association for the Study and Cure of Inebriety, the sum of one hundred dollars is offered by Dr. L. D. Mason, vice-president of the society, for the best original essay on "The Pathological Lesions of Chronic Alcoholism Capable of Microscopic Demonstration." The essay is to be accompanied by carefully prepared microscopic slides, which are to demonstrate clearly and satisfactorily the pathological conditions which the essay considers. Conclusions resulting from experiments on animals will be admissible. Accurate drawings or micro-photographs of the slides are desired. The object of the essay will be to demonstrate, first, are these pathological lesions due to chronic alcoholism? second, are these lesions peculiar or not to chronic alcoholism? The microscopic specimens should be accompanied by an authentic alcoholic history; and other complications, as syphilis, should be excluded. The successful author will be promptly notified of his success, and asked to read and demonstrate his essay personally or by proxy, at a regular or special meeting of the Medical Microscopical Society of Brooklyn. The essay will then be published in the ensuing number of "The Journal of Inebriety" (T. D. Crothers, Hartford, Conn.) as the prize essay, and then returned to the author for further publication, or such use as he may desire. The following gentlemen have consented to act as a committee: W. H. Bates, M.D., chairman, 175 Remsen Street, Brooklyn, N.Y.; John E. Weeks, M.D., 43 West 18th Street, New York; Richmond Lennox, M.D., 164 Montague Street, Brooklyn, N.Y.

—The fourth annual meeting of the Indiana Academy of Science was held from Dec. 25 to Dec. 27 at Indianapolis. On Wednesday night Professor J. P. D. John delivered the presidential address, on "Religion and the Law of Continuity." The programme provides for papers to be read in four sections, — zoölogy; botany; geology and geography; chemistry, physics, and mathematics. Among the papers announced, those on zoölogy outnumber those in any other section.

SCIENCE:

A WEEKLY NEWSPAPER OF ALL THE ARTS AND SCIENCES.

PUBLISHED BY

N. D. C. HODGES,
47 LAFAYETTE PLACE, NEW YORK.

[Entered at New York Post-Office as second-class mail-matter.]

SUBSCRIPTIONS.—United States and Canada.....\$3.50 a year.
Great Britain and Europe.....4.50 a year.Science Club-rates for the United States and Canada (in one remittance):
1 subscription 1 year.....\$ 3.50
2 " " 1 year.....6.00
3 " " 1 year.....8.00
4 " " 1 year.....10.00

Communications will be welcomed from any quarter. Rejected manuscripts will be returned to the authors only when the requisite amount of postage accompanies the manuscript. Whatever is intended for insertion must be authenticated by the name and address of the writer; not necessarily for publication, but as a guaranty of good faith. We do not hold ourselves responsible for any view or opinions expressed in the communications of our correspondents.

VOL. XIII. NEW YORK, JAN. 4, 1889. No. 309.

CONTENTS:

ELECTRIC LIGHTING.—A MODEL CENTRAL STATION.....	1	The Ores of Nickel Mountain.....	10
COAL-MINING MACHINES OPERATED BY ELECTRICITY.....	2	Fossil Wood.....	11
HEALTH MATTERS.		National Geographic Society.....	11
The Germ Theory in Consumption	2	Philosophical Society.....	11
Paster's Method.....	3	COMMERCIAL GEOGRAPHY.	
Inebriate Asylums.....	4	The Iron Industry in the Southern States.....	11
THE NATIONAL ELECTRIC LIGHT ASSOCIATION.....	4	French Kongo.....	11
THE AGASSIZ ASSOCIATION <i>Harlan H. Ballard</i>	5	BOOK-REVIEWS.	
NOTES AND NEWS.....	6	Favorite Authors for Children.....	11
EDITORIAL.....	8	Eating for Strength.....	12
The Hemenway Archaeological Ex- pedition.....	6	A Grammar of the Latin Language	12
AN AMERICAN GEOLOGIC SOCIETY..	8	Modern Heliographic Processes.....	12
AN AUTHORITY DEFINITION OF MANUAL TRAINING.....	9	When Age Grows Young.....	13
SCIENTIFIC NEWS IN WASHINGTON.		The Battle of the Swash and the Capture of Canada.....	13
Sanitary Precautions in Florida... 10		More about the Black Bass.....	13
That "Bureau of Health"..... 10		AMONG THE PUBLISHERS.....	13
Two Other Bills..... 10		LETTERS TO THE EDITOR.	
Oil on Water..... 10		Soaring of Birds <i>J. E. Oliver</i>	15
		Cucullaris Propatagialis in Osci- nine Birds <i>Leonhard Stejneger</i>	16
		ANSWERS.....	16

THE RESULTS of the explorations of the Hemenway South-western Archaeological Expedition in 1887-88, under the direction of Frank Hamilton Cushing, promise to be of the greatest importance to our knowledge of ancient America. The plan of the researches is so comprehensive that we may expect they will clear up the history of the natives of the South-west States and Territories and of northern Mexico,—their somatological character as well as the origin and development of their peculiar culture. Mr. S. Baxter, secretary of the expedition, has recently reviewed the most important results hitherto reached. It has been ascertained that the culture of this region was identical with that of Zuni. The inhabitants of these ancient cities practised an elaborate and thorough system of co-operative river and rain irrigation, and seem to have had a system of canal navigation. They had domesticated animals, notably the turkey, and probably also the rabbit and a variety of the *Auchenia*, or llama. Mr. Cushing has also found facts which lead him to conclude that an entirely indigenous metallurgic art existed; that the natives knew how to reduce ores by smelting, and how to fuse and braze with terra-cotta and cane blowpipes. These researches are of the greatest value, as they are founded on studies of a surviving branch of the peoples once living in these regions, the customs of which serve as a clew to the finds made in the ruined cities. The final results of the expedition will undoubtedly form the starting-point for investigations into the ancient civilization of America.

AN AMERICAN GEOLOGIC SOCIETY.

WITH the activity in geologic investigation during the last decade there has grown up among American geologists the feeling that their work should be more fully co-ordinated and unified, and that more frequent opportunities for personal intercourse should be secured. This feeling took definite shape in 1881, when, at the Cincinnati meeting of the American Association, definite movement was made toward the co-ordination of the Federal and State geologic surveys, and toward the organization of an American geologic society.

The efforts of the geologists in attendance at Cincinnati were not, however, seconded by their absent brethren so warmly as to warrant the founding of the proposed society. The plan has since been kept in mind by its promoters, and during the past summer a call was issued for a meeting of geologists interested in the proposal to form such a society, in Cleveland, on Aug. 14 last. This call was met by a hearty response, and the twoscore of geologists present effected a preliminary organization, adopted a provisional constitution, and appointed a committee to call a subsequent meeting and complete the organization. This committee consisted of Professor Alexander Winchell of the University of Michigan; Professor John J. Stevenson of the University of the City of New York; Professor Charles H. Hitchcock of Dartmouth; Professor John R. Proctor, State geologist of Kentucky; and Professor Edward Orton, State geologist of Ohio.

The meeting for final organization took place in Sage Hall of Cornell University, at Ithaca, on Dec. 27. The attendance was small, but included representatives of a considerable part of the country. Chairman Winchell of the committee on organization presided; a list of 102 geologists, engaged in either original investigation or teaching, who had subscribed to the constitution and paid the entrance-fee, was read; and the provisional constitution prepared at Cleveland was adopted, and the organization thereby rendered complete. The following officers were then elected: president, Professor James Hall, State geologist of New York; first vice-president, Professor James D. Dana, Yale College; second vice-president, Professor Alexander Winchell, University of Michigan; secretary, Professor John J. Stevenson, University of the City of New York; treasurer, Professor Henry S. Williams, Cornell University; executive council, the above-named officers, and the following fellows at large,—Hon. J. W. Powell (director United States Geological Survey), Professor J. S. Newberry (Columbia College), and Professor C. H. Hitchcock (Dartmouth College). Two committees were appointed as follows: committee on revision of provisional constitution, Professor Alexander Winchell, Professor Henry S. Williams, Professor C. H. Hitchcock, Professor J. J. Stevenson, and H. L. Fairchild of the University of Rochester; advisory committee on publications, Professor Joseph LeConte (University of California), Mr. W. J. McGee (United States Geological Survey), Professor N. H. Winchell (State geologist of Minnesota), Professor I. C. White (University of West Virginia), Professor William M. Davis (Harvard University).

According to the terms of the provisional constitution, original fellows of the society comprise working and teaching geologists, who, being members or fellows of the American Association, subscribe to the constitution and pay the entrance-fee before Jan. 1, 1889. In addition to the 102 original fellows thus constituted, sixteen candidates for fellowship were elected at the Cleveland meeting. The society thus starts out with a membership of 118, including nearly every eminent geologist of the United States, and little if any undesirable material, and with a fund (derived wholly from membership-fees) of nearly twelve hundred dollars in the treasury.

It was the prevailing belief at the meeting that the Geologic Society of America is destined to take rank with the leading organizations of related aim in Great Britain, France, Germany, Austria, and other countries; and that, to maintain the high character with which it starts out, it will be necessary to limit the fellowship, and that the legend indicating fellowship in the society ("F.G.S.A.") should be regarded as an honorary title. But one dissenting voice was raised against the last proposition.

The meeting of organization was concluded by an eloquent ad-

dress by the newly elected president, Professor Hall, in which he recounted the history of the development of geologic science in America from its first inception, through the informal meetings of the four State geologists of New York, for discussion of their respective observations, in 1838-40; through the organization of the American Society of Geologists, into which these informal meetings grew, in 1840; through the development of this geologic society into the most powerful scientific organization in the country, the American Association for the Advancement of Science; through the development of the various State and Federal surveys; through the various efforts made for concerted action among American geologists; and down to the completion of the organization of the present society. With every step in this half-century Professor Hall has been identified. The progress has been due to his own efforts perhaps more largely than to those of any other individual. His heart was touched, and his spirit touched, by the recognition of his decades of patient labor; and his picture of the progress of these decades was painted in glowing colors.

The next meeting of the Geologic Society of America will be held at Toronto in August next, in connection with the annual meeting of the American Association for the Advancement of Science.

The Geologic Society of America will hereafter hold regular annual meetings during the holiday week, perhaps in connection with those of the American Society of Naturalists. Biennial meetings for the presentation of papers, for the study of representative geologic areas, etc., will be held each summer in connection with the regular meetings of the American Association, beginning with the Toronto meeting in August next.

AN AUTHORITATIVE DEFINITION OF MANUAL TRAINING.

At the regular semi-annual meeting of the New Jersey Council of Education, held at Trenton, Dec. 26, 1888, a report was received from the special committee on manual training, which contained a definition of manual training. This definition was unanimously indorsed by the council, which is made up of the leading educators of the State. It has therefore more than usual significance, and, if generally adhered to, will not only place the discussion of manual training on the plane which it should occupy, but will render the discussion itself more intelligent and intelligible.

An abstract of the report is presented below. The committee charged with its preparation consisted of Dr. Nicholas Murray Butler of Paterson (chairman), Henry R. Russell of Woodbury, Superintendent C. E. Meleney (now of Somerville, Mass.), S. R. Morse of Atlantic City, and C. C. Stimets of Jersey City.

"It seems most essential at this time that some definite meaning should be attached to the phrase 'manual training,' and some action taken which would clearly indicate the opinion of the council as to exactly what 'manual training' means. It is now used in a variety of senses, and no single, definite idea is connoted by it. We hear of the 'manual-training problem,' the 'manual-training movement,' the 'manual-training school,' 'manual training in connection with geography,' and various other uses of the word, which are strangely incongruous and misleading. Some one use of the word should be selected as the proper one; and it is the opinion of the committee that this council is a body of such educational authority that it may with propriety undertake the decision of this difficult question.

"Sir Philip Magnus, an authority of much weight, says, 'By manual training one commonly means exercises in the use of tools employed in working wood and iron.' Professor Woodward of St. Louis adds to this definition the comment, 'Drawing is understood to be included in the exercises as a matter of course.' These quotations sufficiently illustrate the lack of definiteness with which the term is used even by men of high educational authority. Sir Philip Magnus defines what he means by manual training, and Professor Woodward immediately says that Sir Philip Magnus of course means to include something which he has very evidently intentionally omitted.

"Manual training was first used in this country in the sense in

which Sir Philip Magnus uses the phrase. In the report which Professor Runkle submitted to the trustees of the Massachusetts Institute of Technology, after seeing the European exhibits at the Philadelphia Exposition in 1876, he used the term in this sense; and in consequence of his argument, based in turn upon this use of the term, a school of mechanic arts was added to the courses of instruction already in operation at the institute. It is to be observed that instruction in drawing already formed part of the curriculum of the institute, and that it was not included in the term 'manual training' at the time to which we refer. When, however, the St. Louis manual-training school was founded, and later the manual-training school at Chicago, the phrase 'manual-training' was broadened sufficiently to include instruction in drawing, in addition to the instruction in the tools commonly used in working wood and iron. Judge MacArthur, Mr. Charles H. Ham, Col. Augustus Jacobson, and others who wrote and spoke on the subject of manual training about this time, also used the word in the sense just indicated.

"When, however, the principle of the manual-training school was attacked and criticised, and it became necessary to show on what grounds it could appeal to the public funds for support, it immediately became necessary to examine very critically, not alone the economic arguments which were urged in its favor, but the educational ends which it was expected to serve. It was at once claimed by its advocates that the manual-training school was not a trade school, nor a school for apprentices, but an educational institution, in which certain trades and technical occupations were called upon to furnish material to develop the mental powers of the pupils in certain directions. Immediately this position was taken, it was necessary to show what the mental powers in question were, and why they should be developed in the directions indicated. The advocates of the manual-training school were prompt to reply that that institution was only putting into practice the educational doctrines taught by Comenius and Rousseau, and those which were carried out in another sphere of educational activity by Froebel. With the mention of Froebel and the drawing upon the kindergarten and its fundamental principles for arguments in support of the manual-training school, the narrow conception and application of the word 'manual training' then in vogue broke down, and it began to be used in a much broader as well as a much truer and more significant sense. It is because some who write and speak on this subject use the phrase in its older and narrower acceptance, while others refer to it in its broader and more comprehensive sense, that the confusion to which we have above alluded exists. It seems to us that the council should note carefully the difference between the narrow and the broad use of the phrase, and we urge upon the council the advisability and necessity of giving the weight of its authority to the more liberal application of the words.

" 'Manual training,' in the narrower sense, may be defined as 'exercises in the use of tools commonly used in working wood and iron, together with instruction in drawing.' In this sense, the kindergarten; the movement for drawing and form-study in the primary and grammar schools; the movement for better and more objective methods of teaching history, geography, number, etc.; and the manual-training movement, — are all distinct. That they are, on the contrary, not distinct but closely related, and indeed interdependent, is the decided opinion of your committee. This close relation and interdependence makes the narrower significance of the term 'manual training' at this time an impossible and a wrong one, and lays the basis for the broader and more comprehensive definition. 'Manual training,' in the latter sense, is 'instruction in thought-expression by other means than verbal language and gesture.' It includes necessarily instruction in delineation and instruction in constructive work. Whether or not the tools commonly used for working wood and iron shall be employed for the purposes of giving a part of the instruction in constructive work, is a mere incident.

"We are of opinion that the educational value of proper instruction in the use of tools has been fully proven; but it is not to be supposed that the means of giving instruction in manual training will not improve and develop, as text-books, maps, and other schoolroom apparatus have improved and developed.

"That delineation and construction are natural, early, and simple modes of thought-expression, cannot be doubted, and needs no demonstration before this council. That these modes of mental activity should be trained at school, where the sense-perception, the memory, the reasoning-power, and the verbal expression of thought, are trained, also needs no demonstration. The statement must be accepted as true as soon as it is made; for the proposition that certain mental powers shall be intentionally omitted from the school-training has not as yet found any conscious defenders, though numerous cases might be cited where men have unconsciously argued in support of it.

"The powers of thought-expression by delineation and by construction are among the activities for which Froebel made so prominent a place in his kindergarten. The principle underlying the kindergarten and the manual-training school is one and the same. It must be recognized, and its application extended to the primary and grammar grades. Then we may speak of the manual-training movement and mean something definite thereby, and we may still speak of the manual-training school and mean a school which represents the principle of the manual-training movement in the instruction it offers to pupils of high-school age.

"We urge upon the council the determination to use the phrase in this sense. It is the sense which is warranted by educational history, and the only sense that views manual training as involving the application of a great pedagogic principle, and not as an attempt to improve the methods of high-school instruction alone. We therefore submit the following resolution, and recommend its adoption:—

"Whereas there are several and conflicting uses of the term 'manual training,' be it hereby

"Resolved that the New Jersey Council of Education defines 'manual training' as 'training in thought-expression by other means than gesture and verbal language, in such a carefully graded course of study as shall also provide adequate training for the judgment and the executive faculty.' This training will necessarily include drawing and constructive work, but experience alone can determine by what special means this instruction may best be given."

SCIENTIFIC NEWS IN WASHINGTON.

Sanitary Precautions in Florida. — That "Bureau of Health." — Two Other Bills. — Oil on Water. — The Ores of Nickel Mountain. — Fossil Wood. — National Geographic Society. — Philosophical Society.

Sanitary Precautions in Florida.

THE last three of the weekly health reports of Surgeon-Gen. Hamilton have presented shocking accounts of the deplorable sanitary condition of the cities of Florida, and of the general neglect of health precautions, especially in sewage, that prevails there. The correspondent of "Science" called on Gen. Hamilton, and asked some questions bearing on these reports, eliciting the following statement.

"In general terms," said Gen. Hamilton, "it should be understood that the condition of the towns in Florida, so far as investigated, has revealed a shameful neglect of the commonest sanitary precautions. In Jacksonville the sewage system is quite inadequate, the sewers having been made largely of terra-cotta pipe; and in many of the towns cesspools were constructed where the contents were allowed permanently to percolate the soil. In view of the theory concerning yellow-fever germs being in the alimentary canal and found in the excretions, the conditions existing were exactly those most favorable to the propagation of the disease. If the people of Florida would themselves obey the ordinary laws of self-preservation, and look after their own interests, they would have much less trouble with epidemics. The Federal Government is enforcing in the yellow-fever districts more radical measures than ever before known in the history of this country: establishing gratuitous public laundries for the cleansing of possibly infected bedding and clothes, and fumigating with the consent of municipalities."

That "Bureau of Health."

The following report to the secretary of the treasury, here printed

for the first time, will be likely to seal the fate of the bill which was referred to him for his judgment as to its expediency:—

TREASURY DEPARTMENT,
Office of Supervising Surgeon-General,
U. S. Marine Hospital Service,
Dec. 28, 1888.

The Hon. C. S. FAIRCHILD, Secretary of the Treasury.

Sir, — I have to report, concerning House Bill No. 11,454, that this bill, which offers a reward of \$100,000 to any person of any nationality who discovers the true germ of yellow-fever, is wrongly conceived in my judgment, and should not pass. It was recently made the subject of strong ridicule in the American Health Association, and not a word was raised in its defence. The effect of the mere introduction of the bill has been to flood the bureau with "crank" letters of every description, many of the remedies recommended being preposterous. It will be better for the government to pay the prize as a reward of merit after the discovery shall have been made and established. The history of prizes for the discovery of remedies in times past is a blot on legislation not only in our own country, but in several countries of Europe; and the rewards bestowed have generally turned out to have been improperly given. It is recommended, therefore, that the bill be indefinitely postponed.

Respectfully yours,

JOHN B. HAMILTON,
Supervising Surgeon-General, M. H. S.

Two Other Bills.

Dr. Hamilton has reported favorably on so much of House Bill No. 7,731 as provides for the establishment of a public laboratory in Washington; also on House Bill No. 11,533, providing for a board of yellow-fever commissioners to investigate the sanitary condition of foreign infected places, and to provide for the co-operation of Spain and Mexico.

House Bill No. 11,723, for the creation of a bureau of health, etc., referred to the secretary of the treasury, is reported back to the committee adversely by Dr. Hamilton, whose opinion the secretary asked. It is held that the twenty experts which the bureau would call for could not be had for two reasons: 1. Because there are no such experts whose practice has been limited to scarlet-fever, diphtheria, small-pox, and the like; 2. If there were, \$1,200 a year would not be adequate compensation.

Oil on Water.

The United States Signal Office publishes accounts of eleven vessels which report that they used oil with great effect during the hurricane off the Bahamas in November. The following are some of the reports: Bark "Auburdale" "used oil with great success, safety of vessel and lives of all on board attributed to its use, only four gallons needed;" bark "Hale," "fish-oil used in bags at Cat-heads, vessel and crew saved by its use;" brig "Hussey," "blew a hurricane, lay to, and used oil constantly, thus saving the vessel;" schooner "St. Croix," "in constant danger, but all damage prevented by timely use of oil;" barkentine "Retriever," heavy gale, "but rode it out without breaking a rope-yarn, thanks to the use of oil." The vessels seem generally to have used only a few gallons of oil each.

The Ores of Nickel Mountain.

The interesting ores of Nickel Mountain, Oregon, are described in Dr. Day's new volume of "Mineral Resources of the United States."

"The mountain has an elevation of 2,800 feet above Riddle, or about 3,600 feet above the sea. At an elevation of 1,000 feet above the valley, the nickel ores are first found; and from this height, on all sides of the mountain to the very summit, are found beds of ore covering areas from one to twenty acres, and averaging six feet in thickness. The ores are invariably found either in boulders disseminated through a highly ferruginous earth, or in a stratified bed underlain by an altered serpentine. In places the ore in these beds is not more than a foot in thickness, but in others it will run to a depth of thirty feet. Nothing like vein-formation has yet been encountered. Occurring with the nickel ores is chromic iron and chalcodonic silica. Sometimes the latter contains nickel oxides, forming the beautiful gem stone chrysoptase. Nearly all the hydrated nickel and magnesium silicates are found in greater or less quantities at these mines. No nickel minerals other than the sil-

cates have been found. The ore bodies have been developed by numerous cuts, drifts, shafts, and quarries, all of which are in ore that in bulk contains five per cent of nickel. Some two thousand tons of this class of ore are now on the various dumps. No works have yet been erected for treating the ore, but it is confidently expected that the year 1888 will see this inaugurated.

"A specimen of the unaltered country rock from Nickel Mountain was determined by Mr. George P. Merrill, of the National Museum at Washington, as chiefly olivine, with a mineral of the pyroxene group, probably bronzite. The nickel silicates found near Webster, Jackson County, N.C., are the result of the decomposition of an olivine rock, and the occurrence in southern Oregon can be similarly explained. The association with chrome ores adds to the analogy between the two occurrences.

"Lately Professor F. W. Clarke has further substantiated the view advanced by Mr. Biddle as to the genesis of these silicates of nickel, and has extended the comparison to the silicates from New Caledonia."

Fossil Wood.

In a paper read before the Biological Society, Washington, F. H. Knowlton comes to the conclusion that the fossil wood of the Potomac formation is all coniferous. It exists under two different conditions; viz., as a silicified wood, and as lignite, which, owing to the great pressure to which it has been subjected, is much metamorphosed and distorted, and is incapable of specific determination. The former, very perfectly preserved, belongs to two genera, — *Cupressinoxylon*, with four species; and *Araucarioxylon*, with a single species.

National Geographic Society.

The National Geographic Society held its annual meeting for election of officers, presentation of reports, etc., on Friday evening, Dec. 28. The secretaries and treasurer presented their annual reports, and officers were elected for the year 1889 as follows: president, Gardiner G. Hubbard; vice-presidents, H. G. Ogden, G. L. Dyer, A. W. Greely, C. Hart Merriam, A. H. Thompson; treasurer, C. J. Bell; secretaries, Henry Gannett, George Kennan; board of managers, Cleveland Abbe, Marcus Baker, Rogers Birnie, jun., G. Brown Goode, C. A. Kenaston, W. B. Powell, O. H. Tittmann, J. C. Welling.

Philosophical Society.

The Philosophical Society, Washington, elected its annual officers as follows: president, J. R. Eastman; vice-presidents, C. E. Dutton, G. K. Gilbert, G. Brown Goode, H. H. Bates; treasurer, Robert Fletcher; secretaries, W. C. Winlock, J. S. Diller; members at large of the general committee, W. H. Dall, J. H. Kidder, H. M. Paul, F. W. Clarke, C. V. Riley, R. S. Woodward, L. F. Ward, G. W. Hill, Marcus Baker.

COMMERCIAL GEOGRAPHY.

The Iron Industry in the Southern States.

In the "Report on the Mineral Resources of the United States for 1887," recently issued by the United States Geological Survey, James M. Swank gives an interesting report of the recent rapid growth of the Southern iron industry. The activity which was so conspicuous in the latter half of 1885 and in 1886 was continued in 1887 and during the first half of 1888. This activity has been chiefly displayed in the erection of blast-furnaces for the manufacture of pig-iron.

Since the beginning of 1886 there have been built in the States south of the Potomac and the Ohio Rivers twenty-one large and well-equipped furnaces, and fourteen furnaces were in course of erection in those States on July 1, 1888. The total number of furnaces which were in blast on that date, not including those of Missouri, was 109.

There was much comment in Southern newspapers concerning the probable scarcity of a supply of good coke for the new southern furnaces, and the prediction was freely made that some of the new furnaces would be compelled to remain idle until new coal-fields could be found, or fields already discovered could be developed. With the lapse of time it has been found that the supply of good coke from Southern coal-fields has fairly, if not entirely, kept pace with the increasing demand for this fuel for furnace use. New coke-ovens have been built in connection with newly opened coal-

mines, and the quality of coke obtained from the coal of some of the older mines has been improved by more careful methods of selecting the coal and making the coke. There is particularly no longer any apprehension of a scarcity of coke for the supply of the furnaces at Birmingham and in its vicinity. A great portion of the supply is furnished from the New River coal-field in West Virginia, and the Pocahontas coal-field in Virginia. The coke from these fields has been shipped to Carondelet, Mo., and Chicago, at which places it has been used in blast-furnaces in competition with Connellsville coke.

The future of the iron industry of the South appears very promising, as there are certain advantages which other parts of the United States do not enjoy. In Alabama and Tennessee, ores and fuel are found in close proximity, and unskilled labor is cheaper than in the North; but, on the other hand, much of the pig-iron made in these States must be hauled to distant markets at great expense. In fact, no section of our country possesses a monopoly of all the advantages for producing iron and steel. Pittsburg has natural gas for its rolling-mills and steel-works, and is close to the Connellsville coke-field, but it brings its ores long distances. Chicago is nearer than Pittsburg to Lake Superior ores; but it is hundreds of miles away from Connellsville coke, and it lacks natural gas as a substitute for raw bituminous coal. In New England but little iron and steel in their crude forms are now made, but the skill in their manipulation which has been accumulated in two hundred years yet remains. The iron industry of the Rocky Mountain region will always have the stimulus of a home market remote from destructive competition. There is room in almost every section of this great country for the iron and steel industries, which have in later years been so wonderfully developed, and which are destined to expand still further.

FRANCH KONGO. — In order to develop the resources of the French Kongo, it has been proposed to establish a line of steamers running between some French port, Senegambia, and Gabon-Kongo. It is estimated that the line will require an annual subsidy of \$140,000. While the Marseilles Geographical Society indorses this scheme, Lieut. Mizon, who spent many years in the interior of the colony, and to whom we owe our present knowledge of its topography, opposes it, on the ground that the trade of the colony is unable to sustain an additional line of steamers. His remarks show that the French Kongo has developed very slowly since 1870. In that year the colony embraced the Bay of Gabon and the delta of the Ogowe. Its trade amounted to \$500,000 annually. In the following years it did not increase; but, after De Brazza's exploration of the upper Ogowe, more caoutchouc and ivory were shipped. At the same time, however, the trade in dye-woods, ebony, and wax, declined on account of the devastation of the forests. The total amount of import and export in 1882 was estimated at about \$2,000,000. Since that time it has not increased. This trade is principally in the hands of an English and a German house, who have regular lines calling in all parts of any importance between Madeira and the mouth of the Kongo; and even to them the produce of the Gabon is of little importance as compared to that of other parts of the coast. The slowness of progress in the French Kongo is principally attributed to the lack of communication with the interior and the absence of factories on the head waters of the rivers. The resources of the interior must be developed, and the natives induced to sell their goods to trading-posts in the interior, which will thus be able to collect enough valuable cargo to make the trade between Europe and Gabon more remunerative. Lieut. Mizon's considerations are of special interest when compared to the actions of the Belgian Company trading with the upper Kongo. The latter concentrates all its energies upon the establishment of good communication with the upper Kongo, and to a systematic exploration of the commercial products of that region. Undoubtedly its endeavors will finally result in producing a remunerative traffic between the remote regions of Central Africa and Europe.

BOOK-REVIEWS.

Favorite Authors for Children. By Mrs. FRANCES A. HUMPHREY. Chicago and Boston, Interstate Publ. Co. 16^o.

This little book contains brief sketches of certain authors who have written more or less for young people, though only a few of

them have made a specialty of such writing. They are twelve in number, some of them still living, while others are dead, and all are Americans. Mrs. Humphrey's object in writing the book has been to give children some idea of the authors themselves as men and women rather than to criticise or describe their writings. Only a few of their more popular works are noticed at much length, the rest being merely mentioned; but many interesting anecdotes of the authors themselves are related, and all in a style that young readers will not only understand, but enjoy. Some of the authors, such as Longfellow, Bryant, Holmes, and Mrs. Stowe, are quite widely known, while others have a narrower reputation; but an author's capacity as a writer for children is not to be measured by his success in other directions. It is evident, too, that the fashion in children's books varies from age to age; for those here noticed are quite different from the Rollo books and the writings of "Peter Parley," which were in vogue forty years ago. Mrs. Humphrey's book gives portraits of all the authors mentioned, which will add greatly to its attractiveness for children; and they will perhaps wish that she had added her own to the list.

Eating for Strength; or, Food and Diet in their Relation to Health and Work. By M. L. HOLBROOK, M.D. New York, M. L. Holbrook & Co. 12°.

In this volume of only 236 pages, the author has discussed a great variety of subjects. He has attempted to combine so much of physiology as concerns digestion with a practical cook-book, and has added a chapter on the alimentary products of the vegetable kingdom. This is one of the books which, so far as we can judge, supplies no want, and its *raison d'être* is inexplicable. The physiology of digestion is much better described in all the school physiologies, and the recipes for the kitchen contain nothing that is especially new or valuable. The composition of the volume is careless, singular verbs frequently being called upon to do duty for a plural subject. There are portions of the book from which teachers could select admirable examples of how sentences should *not* be constructed. We select one of these as an illustration: "After the stomach has done all it can in the way of digesting the albuminous matter in our food, it is passed through the pyloric orifice at its end into the duodenum, in an acid condition." We do not blame the stomach for being in an acid condition, if, after having done its full digestive duty, it is passed through the pyloric orifice into the duodenum. Such treatment would be apt to "sour" the most patient organ in the body; and even the stomach, which has the reputation of being "long-suffering," might justly display its displeasure if called upon to suffer this distortion but once, and much more if asked to do it three times a day throughout a natural lifetime. Other examples of careless composition might be mentioned, but they would add nothing to the one we have selected.

The author's chemistry is equally faulty with his composition. In speaking of the carbo-hydrates, he says that they are called "carbo-hydrates" because chemically composed of carbon and water, and then follows with the remarkable statement that the chemical formula of cane-sugar is, carbon, 12; hydrogen, 11; oxygen, 11; and that of grape-sugar, carbon, 12; hydrogen, 12; and oxygen, 12.

Taken as a whole, this book is one we not only cannot recommend, but which we deem it our duty to condemn.

A Grammar of the Latin Language for the Use of Schools and Colleges. By E. A. ANDREWS and S. STODDARD. Revised by Henry Preble. Boston, Houghton, Mifflin, & Co. 12°. \$1.12.

In the thirty years since this grammar was last revised, opinions have changed somewhat as to what the contents of such a book should be, and how they should be presented. The reviser has consequently found himself driven further and further from the earlier form of the grammar, and has moulded his materials into a form corresponding better with the present state of Latin philology. Most of the old paradigms have been retained, and others have been added. In the case of the regular verb, the four conjugations are printed side by side, so that they are more easily seen to be really varieties of one conjugation, and their forms are more easily implanted in the memory than when learned in four isolated groups.

Many of the old examples also remain, and some new ones have been introduced.

The general sequence of topics has not been greatly altered, the most important changes being the following: The sections treating of word-formation have been gathered into one place, instead of being distributed among the different parts of speech in connection with their inflection; and the treatment of word-formation is made more effective by giving the pupil some insight into the processes of the growth of words instead of merely classifying derivatives according to their apparent endings. The treatment of adverbs (except their comparison), prepositions, and other particles, has been transferred partly to "Word-Formation," and partly to "Syntax." The rules of quantity have been brought into the early part of the book instead of being relegated to "Versification;" and, while the rules of agreement for adjectives and pronouns remain in their old place at the beginning of "Syntax," the rest of the syntax of such words has been postponed till after the treatment of the cases, in order to secure a more natural progression in the study of syntactic details. On account of the necessary introduction of new matter, no attempt has been made to retain the old numbering of the sections; and the book is divided only into sections and sub-sections, with occasional notes; the three kinds of divisions being distinguished by type of different sizes, the main sections sometimes consisting of two or three numbered paragraphs. This arrangement allows a most detailed reference without the use of long or complicated indications. In the matter of pronunciation the reviser makes no reference to what is known as the English method, for the reason, he says, that "the time seems ripe for sparing the teacher the necessity of choosing between a system accepted by the scholarly world as substantially correct, and one which, though still somewhat sheltered by a conservative tradition, makes the mastery of quantity and even of word-formation unnecessarily difficult.

The third declension is made less of a stumbling-block to young learners by grouping the consonant-stems simply according to their behavior toward the letter *s*, and by presenting the *z*-stems in a progressive series, showing different stages in the absorption of consonant-stem forms. Examples in the use of the subjunctive mood have been supplied with unusual copiousness, in the belief that the contemplation of examples is the surest way to acquire a feeling for the subtle differences between the subjunctive and the indicative. The reviser has evidently tried to keep in mind the needs of the beginner, and, when it has been necessary to introduce the results of modern philological research, they are stated as simply and definitively as possible. At the same time the more advanced pupil is furnished with all that is essential to his work, both at school and in college, until the time when an exhaustive grammar becomes a necessity to him. The more difficult topics are treated in such a way as to be clear, while leaving as little as possible to be unlearned when the pupil's study becomes more mature and scientific. Thus, among many things, the growing custom of German scholars in abandoning the character *j* is followed, while the distinction between *z* and *v* is retained.

The exclusion from the present edition of a mass of details, such as rare exceptions to rules and small irregularities in the linguistic usage of the less-known Latin writers, has failed to reduce the size of the book, because of the improvement in the size of the type which the publishers have been good enough to make. The large type, clear print, good paper, and neat binding make as good a setting as the learned reviser could desire for the result of his labors.

Modern Heliographic Processes. By ERNST LIETZE. New York, Van Nostrand. 8°.

THE present book had its origin in a lecture delivered by the author in 1885. On being requested to publish this lecture in the form of a pamphlet, the author extended his studies and researches, compiling the numerous recipes and suggestions scattered in journals and books, and ascertaining their value. The book is intended for the use of engineers and draughtsmen, who are so frequently in need of a good process for reproducing their drawings. After a brief theoretical introduction on the chemical and physical action of light, the author classifies the processes as processes with salts

of silver, with iron salts, with salts of chromium, and with salts of uranium. He gives practical instructions in regard to the paper to be used, the methods of sensitizing, and the trays and dishes used for the purpose, and describes various forms of printing-frames. He then proceeds to describe the numerous processes that have been suggested, and states their advantages and disadvantages. Formulæ which were found not practical, but which are recommended by reliable authorities, have also been given. The patented processes are included, although they cannot be used generally, in order to give a complete review of the subject treated. The first thousand copies of the book are accompanied by ten specimens of heliographic prints, among which the uranium and carbon prints deserve special mention. The first chapters, in which the methods of sensitizing and printing are described, are accompanied by numerous figures illustrating the instruments and processes.

When Age Grows Young. By HYLAND C. KIRK. New York, Dillingham, 16°. 50 cents.

THE author of this work published a few years ago a speculation on the possibility of not dying, in which he undertook to maintain that it was possible to prolong human physical life indefinitely; and now, in accordance with the fashion of the time, he comes before us with a romance in which he maintains the same view. The story has no very consistent plot, but contains a considerable variety of incident of a more or less interesting character. The principal personage in the story, however, who is known as Daniel Ritter, and who is the advocate of the theory of physical immortality, is by no means an agreeable character. He has some pleasing traits, and is gifted with the power of telepathy, on which some of the main incidents of the story are made to turn. But he wishes to obtain twenty thousand dollars in order to marry the girl he loves, and gets it by defrauding an insurance company. As for the possibility of not dying, which "Ritter" maintains, it depends, we are told, on certain conditions. The first is "to believe it possible;" the second, "to be in accord with the Will of the Universe;" the third, "to make the cause of humanity your own;" and "the final step is the triumph of love in life," whatever that may mean. Now, without entering into the biological objections to such a theory, we would remark that the first of these conditions seems to be the most difficult of attainment. We are told by the prophet of an older gospel that if we have sufficient faith we can remove mountains, but the difficulty with most people is to get the faith, and we apprehend that Mr. Kirk's doctrine will encounter the same obstacle. However, if any one wishes to learn about the theory, he will take an interest in reading this book; for it has at least the literary merit of being written in a good style.

The Battle of the Swash and the Capture of Canada. By SAMUEL BARTON. New York, C. T. Dillingham. 16°. 50 cents.

THIS little book is of the "Battle of Dorking" class. It purports to be an account of an attack upon New York by a British fleet in the year 1890, together with other exciting events, including the capture of Canada, which occurred in the same year. The reason for the book's existence, and the keynote of the author's rather lively tone, may be found in the dedication of the volume, which runs as follows:—

"To the senators and ex-senators, members and ex-members, of past and present Congresses of the United States of America, who, by their stupid and criminal neglect to adopt ordinary defensive precautions, or to encourage the reconstruction of the American merchant marine, have rendered all American seaport towns liable to such an attack as is herein but faintly and imperfectly described, this historical forecast is dedicated; with much indignation and contempt, and little or no respect."

The author "makes his title clear" by explaining to those of his readers not familiar with New York waters that the Swash is a straight channel, forming a sort of hypothenuse to the two sides of the main ship-channel, which bends almost at right angles at the south-west spit in the outer bay. The admiral of the British fleet selected this channel as his base of operations against New York. "Blinding buoys," torpedoes and torpedo-boats, dynamite guns and gunboats, submarine boats, and various other devices, played a

more or less important part in defending the city against the enemy. But the most effective work was done by two insignificant-looking boats,—evidently invented by the author,—which involved a new principle of marine warfare as applicable to harbor defence. These boats carried no arms or ammunition excepting a hollow steel ram containing two tons of dynamite. Almost completely submerged, and travelling at a speed of thirty miles an hour, they made for two of the most formidable of the British ironclads. When so close to their victims that there was no risk of missing the mark, the pilots of the boats, the only men remaining aboard, quietly dropped overboard, to be afterward picked up. The rams penetrate the sides of the ironclads, two explosions follow, and there is nothing left of either but fragments. Notwithstanding all this, the British fleet enters the upper bay, and at the end of two days' bombardment, the Brooklyn navy-yard, the East River bridge, and the lower part of New York City are utterly destroyed.

But the book must be read to be appreciated. It is well written and interesting, and puts into striking form the essence of the many arguments advanced from time to time for "restoring our merchant marine, strengthening our coast defences and the navy, and supplementing the latter by a naval reserve."

More about the Black Bass. By JAMES A. HENSHALL, M.D. Cincinnati, Robert Clarke & Co. 12°. \$1.50.

THIS volume is a supplement to the "Book of the Black Bass," by the same author, who is an expert angler and an eminently practical writer on black bass and bass-fishing. He has thought it best to issue this supplement in a separate volume, letting the original edition remain intact, the chapters in both volumes being so arranged as to agree in number and caption. The plan pursued in the original book, of illustrating the tools and tackle by engravings especially prepared for manufacturers, to illustrate their different lines of specialties, has been adhered to in the supplement.

The book is divided into three parts. The first part treats of the scientific history, nomenclature and morphology, general and special features, coloration, geographical distribution, habits, and intelligence and special senses of the black bass, and on stocking inland waters with them. Fishing rods, reels, lines, hooks, artificial flies, artificial and natural baits, and miscellaneous implements, receive attention in the second part. The third part is devoted to the philosophy of angling, conditions governing the biting of fish, the black bass as a game-fish, fly-fishing, casting the minnow, still-fishing, trolling, and skittering and bobbing. The volume will be welcomed by every genuine angler who "loves angling for its own sake," while even the pot-fisher, who "likes fishing for the spoils it brings," may find in it valuable hints that will increase his income.

AMONG THE PUBLISHERS.

AT last we are treated to a novelty in the way of almanac-making. Dr. J. C. Ayer & Co., the well-known manufacturers of Ayer's sarsaparilla, Lowell, Mass., send us their "Almanac for 1889," in the shape of a good-sized book, embracing editions in English, calculated for the various sections of the United States, the Dominion of Canada, India, South Africa, and Australia; also editions in nine other languages. The volume contains, also, specimen pages of pamphlets issued by the company in eleven languages not represented by the almanacs, including Greek, Turkish, Armenian, Chinese, Burmese, and Hawaiian,—twenty-one languages in all. From the preface we learn that no fewer than fourteen millions of these almanacs are printed yearly. A copy of this favorite almanac may be had at your druggist's. It is a species of "yellow covered literature" of value.

—Never without some papers which are sterling contributions to political and social science, "The Atlantic" for January has in this department "A Difficult Problem in Politics," by Frank Gaylord Cook, the problem being how to attain "uniform legislation" throughout the Union; and one of Lillie Chace Wyman's "Studies of Factory Life," this time of the relation of "The American and the Mill." Professor Shaler of Harvard University considers "The Athletic Problem in Education;" and there are papers by Philip Dymond, on "Von Moltke's Characteristics," and by John Fiske, on "Washington's Great Campaign of 1776."

— The most important article in the "Political Science Quarterly" for December is by Professor Theodore W. Dwight, on "The Legality of 'Trusts.'" The writer considers the common-law doctrine respecting restraint of trade, and other principles bearing on the question, and reaches the conclusion that trusts are partnerships, like any others, and that unless they can be shown to have been formed *with the intent* of raising prices unduly, or for some other distinctly unlawful purpose, they are lawful under the law as it now stands. He then goes on to maintain that the constitutional provision that no man shall be deprived of liberty without due process of law, forbids the State to interfere with them; or, in his own words, if the trust "is *now* lawful as a reasonable and proper element in production, it cannot properly be made unlawful by legislative acts of a stigmatizing character;" which seems rather singular doctrine. The sale of intoxicating liquors is now lawful in the State of New York; but is the Legislature forbidden by the Constitution to prohibit it? Besides this paper of Professor Dwight's, there is an article by Professor Hadley on "Public Business Management" that is worthy of attention. The writer considers the question in various aspects and with reference to recent examples, and reaches the conclusion that the management of business enterprises by the State or the city has not thus far proved very successful. On the other hand, Mr. William Clarke, in discussing "Socialism in English Politics," maintains the opposite view, and predicts the rapid growth of State socialism in England. Professor Burgess treats of the law recently passed, regulating the electoral count, by the Houses of Congress, and pronounces it nothing but a makeshift. The concluding essay in the review is by two English writers, on "The Ballot in England," and gives both a history of the subject and an account of the kind of ballot now in use there. At the present time, when the question of ballot reform has become important in America, this article will be found useful.

— The Worthington Co. have ready "Our Presidents," by Virginia F. Townsend, giving the lives of the twenty-two Presidents of the United States, enlivened by anecdotes and romantic incidents in the lives of the men who received the highest honor in the gift of their countrymen. The fine steel portraits of these men are the work of H. B. Hall & Sons, and are executed with great care. In these days of all sorts and conditions of reproduction processes, it is a rest to the eyes to see the solid steel engravings of former days once more. The publishers get out this timely work in an *édition de luxe* limited to five hundred copies, with portraits printed on India paper, and the volume is handsomely and appropriately bound in rich red cloth with title on white label.

— G. W. Smalley, in the "New York Tribune," Dec. 14, states that an interesting, even surprising fact relating to America came out at Dr. Robertson Smith's dinner to the "Encyclopædia Britannica" contributors. Mr. Black, one of the publishers, told the company the entire circulation of the new ninth edition was fifty thousand copies, of which forty thousand went to the United States; Americans, that is, have bought four times as many copies of the best English encyclopædia as the English themselves have. America has, in fact, absorbed a million quarto volumes of this great work. These figures, we presume, refer only to the editions handled in this country by Little, Brown, & Co. and Charles Scribner's Sons, and do not include the two reprints of the J. M. Stoddard Co. and of the combination using the photographic process.

— From January, 1889, when Vol. XI. will begin, "The American Chemical Journal" will appear in *eight numbers a year, instead of six as heretofore*. As far as may be practicable, one number of about seventy-two pages will be issued each month of the year, excepting July, August, September, and October. For some time past the supply of articles submitted for publication has been so great as to require the entire space of the journal, and the editor has found it impossible to continue the reviews, reports, and abstracts which formed a somewhat prominent feature of the earlier volumes. It is proposed now to restore this feature, and a strong effort will be made to secure such reviews and reports as will give a fair idea of the progress of chemistry in its various branches. In consequence of the increase of size, the price will be

raised from three dollars to four dollars a volume. Hereafter all communications in regard to subscriptions should be addressed to the *Publication Agency of the Johns Hopkins University, Baltimore, Md.*; and editorial communications, to the editor, Ira Remsen, *Post Office Drawer 2, Baltimore, Md.*

— The "Journal of Morphology" for November (Boston, Ginn & Co.) contains the following interesting articles: "On the Development of *Manicina Areolata*," by Henry V. Wilson; "The Structure and Development of the Visual Area in the Trilobite, *Phacops Rana*, Green," by John M. Clarke; "Further Studies on *Grammicolepis Brachiusculus*, Poey," by R. W. Shufeldt; "On the Relations of the Hyoid and Otic Elements of the Skeleton in the Batrachia," by E. D. Cope; and "On the Affinities of *Aphriza Virgata*," by R. W. Shufeldt.

— "Writing for Young People — Ideal," "Shorthand for Literary Purposes," "Mental Dyspepsia," "Statute Regulations for the Press," "On Quoting," and "Learning to Write," are among the topics discussed in the January number of "The Writer." This unique magazine for literary workers is now in its third volume.

— An interesting experiment in bringing up a baby without shoes and stockings is described at length in the January number of "Babyhood." The experiment was successful, but the medical editor takes occasion to protest against the "hardening process" to which some parents submit their children. "Chilblains and frost-bites" is just now a very reasonable subject, and it is not often that one finds so practical and authoritative a treatment of it as Dr. Bissell offers to the readers of "Babyhood." "Learning to Walk," by Dr. Canfield, deals with a subject of perennial interest to mothers of young children. "Home Instruction for Little Children" will be found particularly valuable in households where the nursery begins to expand into the schoolroom. The letters contributed by mothers include a vigorous protest against the absence of sleeping-car comforts for ladies and children, a rather despairing inquiry as to the limit of a mother's devotion to her children, a striking illustration of the dangers of the fruit-diet to expectant mothers, etc. The "Nursery Observations" record many amusing and curious traits of young children, and the answers to "Nursery Problems" are instructive.

— The "Quarterly Journal of Economics" for January is a university number. Professor Andrews of Cornell writes upon "Trusts;" Professor Patten of Pennsylvania, on "Capital;" Professor Hadley of Yale, on "The Railroads under the Interstate Commerce Law;" and Professor Edgeworth of King's College, London, on "The Appreciation of Gold." Harvard is represented by a copious array of notes and memoranda on various interesting topics, and a review of "The Tariff Literature of the Campaign," and an historical paper on the suspension of specie payment in Italy in 1866, written as a university study by A. B. Houghton in 1886, and now issued as an appendix to this number.

— The long-announced articles by Mr. Charles DeKay, on Ireland, begin in the January "Century;" the first being entitled "Pagan Ireland," with illustrations of the mediæval castle at Clonmiconis, the Cross at Monasterboice, the round tower at Ardmore, etc. Mr. Wilson, the photographer, continues his series on the Holy Land in connection with the International Sunday-School Lessons. The present instalment, profusely illustrated, is entitled "Round about Galilee." The Lincoln life in this number deals with three commanding events. — Pope's Virginia campaign, the battle of Antietam, and the announcement of emancipation. An illustrated article on "The West Point of the Confederacy" gives an account of a battle the details of which are little known in the North, and in which the cadets of the Virginia Military Institute at Lexington took a conspicuous and romantic part, suffering heavily in killed and wounded. An essay by Col. Auchmuty tells about a new movement in connection with the subject of American labor. This essay is entitled "An American Apprenticeship System," and describes a new system of apprenticeship, which Col. Auchmuty considers "suitable to American wants," and which he says "concerns in no small degree the welfare of the nation." Mr. Frederic Remington, the artist, himself writes as well as illustrates

an article entitled "Horses of the Plains." Mr. Kennan, in an article entitled "The Life of Administrative Exiles," presents some of the most astounding facts gathered by him in Siberia. The article is without illustrations. The writer says in introducing it, that to present a large number of closely related facts concerning this branch of the subject in the chronological order in which they were obtained would be to scatter them through half a dozen articles, and thus deprive them of much of their cumulative force and significance. He therefore groups these facts in a single paper, which necessitates a brief interruption of the narrative, and an omission, for a single number, of the illustrations. This, he remarks, enables him to deal broadly and comprehensively with one of the most interesting and important phases of the exile system. In "Topics of the Time" are discussed "Annexation, or Federation?" "Separate Municipal Elections," the question "Are We Just to our Architects?" and "A Crisis in the Copyright Agitation." "Open Letters" deal with "Lawyers' Morals," the "Life of Lincoln," and "The Mother's Right."

—In the January "Popular Science Monthly" there are four illustrated articles, one of which, "The Guiding-Needle on an Iron Ship," opens the number. In this paper, Lieut.-Commander T. A. Lyons, U.S.N., tells why the various masses of iron on shipboard interfere with the working of the compass, and explains how the trouble is remedied. "House-Drainage from Various Points of View," is the title under which Dr. John S. Billings, U.S.A., describes, with illustrations, the present condition of this complex problem. Very timely and interesting is Mr. W. H. Larrabee's copiously illustrated paper on "Sea-Lions and Fur-Seals." Two articles that will interest teachers and parents are "The Sacrifice of Education," a protest against the abuse of examinations; and "Inventional Geometry," by E. R. Shaw, which tells how geometry has been made a pleasure to pupils using the book prepared by Herbert Spencer's father. Eighteen drawings made by boys and girls in working out the problems are inserted. "Town-Life as a Cause of Degeneracy," is the subject of an instructive paper by G. B. Barron, M.D. The nature of "Genius and Talent" is described by Grant Allen in his peculiarly happy vein. W. D. Le Sueur contributes a strong article under the title "Science and its Accusers," in which he affirms that science is simply truth, and that, while men and theories may properly be criticised, opposition to science is absurd and vain. Professor Langley's address on "The History of a Doctrine" is concluded in this number. "The Suanetians and their Home," is an account, by D. W. Freshfield, of an interesting people dwelling in the Caucasus region. Some additional facts concerning "Gauss and the Electric Telegraph" are given, and the subject of the usual sketch and portrait is Rev. Moses Ashley Curtis, the North Carolina botanist. Professor C. H. A. Bulkeley, D.D., contributes a letter on "The Relation of Altruism to Egoism," criticising Mr. Smiley's recent article. The "Editor's Table" deals with "The March of Practical Science" and "The Abuse of Examinations;" and the "Miscellany" and "Notes" are varied and instructive.

—The tenth volume of the "Proceedings of the United States National Museum" has just been issued. The signatures composing the volume were issued from April, 1887, to October, 1888. Like the preceding issues, the volume contains primarily essays on zoological subjects, although others are not wanting. The greater part of the work is occupied by papers prepared by the scientific corps of the National Museum, while others treat upon the collections of the museum. In an appendix a catalogue of the contributions of the section of graphic arts to the Ohio Valley Centennial Exposition at Cincinnati is given.

—The fifth volume of the "Mineral Resources of the United States," by David T. Day, has just been issued by the United States Geological Survey. It covers the calendar year 1887. The statistical tables contained in the former volumes have been brought forward, but repetition of descriptive matter has been avoided wherever possible. The result of Professor Day's careful investigations shows an aggregate value of \$538,056,345 for the mineral industries of the United States. This is nearly \$73,000,000 more than the product in 1886, and considerably more than \$100,000,000 in

excess of the year 1885. Of many items which have contributed to this result, all the metals increased in quantity, except gold and the minor metal nickel, and nearly all increased in price. The significance of this is seen in the increased production of the fuels necessary for reducing these metals and preparing them for use. All of these fuels, including natural gas, show a marked increase. The value of building-stone increased considerably, but this apparent advance is principally due to a more careful canvass of this industry than has been possible in previous years. Professor Day does not consider it probable that the great total recorded for 1887 will be equalled in the present year.

— "A Course of Mineralogy for Young People" (Agassiz Association course) is published by G. Guttenberg, teacher of natural sciences in the Erie High School, Erie, Penn. In this course it has been attempted to present the study of stones in such a manner that any bright boy or girl over twelve years of age can, without the aid of a teacher, become a fair mineralogist, being able to examine and determine all of the more important minerals, including the ores of the useful metals.

—The new edition (1889) of "The Electricians' Directory and Handbook" is in preparation. It is published at "The Electrician" office, 1 Salisbury Court, Fleet Street, London, E.C.

—An arrangement has been made by which the "Political Science Quarterly" and "The New Princeton Review" are consolidated. The publishers of the "Political Science Quarterly" (Ginn & Co.) have purchased "The New Princeton Review," and the latter journal will be merged into the former. The political and economic questions to which "The New Princeton Review" has devoted so much of its attention, and which are engrossing more and more the attention of the public, will form, as heretofore, the special field of the "Political Science Quarterly." The point of view and method of treatment which have won for both journals such cordial recognition and such extensive support will remain unchanged. Certain features of "The New Princeton Review" which have specially commended themselves to the public will be incorporated in the "Political Science Quarterly;" and as Professor Sloane, the editor of "The New Princeton Review," will be associated in future with the work of the "Political Science Quarterly," the cause of sound politics can only gain by this union of forces.

—Laidlaw Bros. & Co., 137 West 41st Street, New York City, have just issued "The Declaration of Independence and the Constitution of the United States, in German, French, and English, in Parallel Columns," translated by A. H. Laidlaw, jun.; French and German revised by Professors Hellmrich, Schoeder, and Fezandé. The translations have been carefully made. Historical notes have been interspersed throughout the work, and an appendix supplies interesting tables on matters of permanent importance. Blank pages have been added for the reception of grammatical and historical notes, for the insertion of appropriate clippings from periodicals, and for the collection of references to interesting pages of other works.

LETTERS TO THE EDITOR.

*.*Correspondents are requested to be as brief as possible. The writer's name is in all cases required as proof of good faith.

Twenty copies of the number containing his communication will be furnished free to any correspondent on request.

The editor will be glad to publish any queries consonant with the character of the journal.

The Soaring of Birds.

To the tests proposed in "Science" (Dec. 7, pp. 267, 268) for Mr. Gilbert's ingenious hypothesis that birds, in soaring, utilize the varying velocities and directions of the horizontal air-currents at different levels, one might perhaps add this: that the inclined planes of the circles described should be observably related to the direction, etc., of the wind at the earth's surface, and of the cloud-drift above. For instance: if the upper current, relatively to the lower, was from the north, we might expect the higher side of the circle to be the north side, or else to be that side along which the bird was flying southward.

The action suggested would clearly be to some extent *efficient*, but would it also be *sufficient*? Can the gradients of velocity, etc. from level to level in air-currents far above us, be rapid enough to give the bird more than a slight assistance, although perhaps I would still avail himself of even that little help? For here is much more than "friction" to be overcome. If a hawk, weighing pound or more to every square foot of effective wing and to surface, would fall through the air with outspread motionless wings ten miles an hour, which I believe to be a low estimate, the bird to sustain his weight without muscular effort, his horizontal velocity relative to the surrounding air should be not less than fifteen miles an hour. Can it be that air-currents hundreds of feet from earth, and only a few yards apart, often differ in velocity so much as that? And yet I have seen no other theory that could in the least explain the prolonged soaring of birds, if, indeed, their wings do remain motionless. Much has been said of late, in "Science" and elsewhere, of the locking of certain wing-joints: but this admirable contrivance for relieving muscular fatigue is quite irrelevant to the present problem; for, as Mr. Gilbert has recognized, it prevents not a foot-pound of that actual work which, to prevent a fall of miles per hour, must be expended at a rate of thirty mile-pounds per hour if the bird weighs three pounds.

A naval officer, whose name I forget, once told me of an observation of his own, which, if confirmed, would remove all difficulties. Standing on deck in mid-ocean in a stiff breeze, he observed certain sea-birds hovering near him with apparently unmoving wings, though holding their own against the wind. But when they came within a few yards, he could see that the outspread wings had in reality a rapid motion of very small amplitude, almost a mere tremor. His impression was, that, though the wings had not sufficient play to present the whole wing edgewise to the air during the up-stroke, and flatwise during the down-stroke, yet the individual wing-feathers might be doing this, their vanes automatically separating and turning edgewise, opening like valves or like slats of a blind, as the wing rose, and closing up again, as it fell, by the action of the air itself. Some such action of the feathers would greatly aid this kind of flight. It is for naturalists to say how well they are adapted to it, and whether such flight might be possible while the wing-joints remained locked, and whether it might therefore be sometimes a restful change for the bird.

J. E. OLIVER.

Cornell University, Dec. 19.

Cucullaris Propatagialis in Oscinine Birds.

SOME time ago ("Science," ix. 1887, pp. 623, 624), Dr. R. W. Shufeldt announced the alleged discovery in the bird-wing, of a muscle well known as *Cucullaris propatagialis*, as being particularly characteristic of the suborder *Oscines* (or, as I call them, the superfamily *Passeroidea*), special stress being laid on its taxonomic value in distinguishing the latter from the mesomyodian *Passeres*. In a subsequent number of "Science" (x. 1887, pp. 70-72) I demonstrated that the muscle in question is particularly well developed in parrots and woodpeckers; and I also stated that I had found it, though in a rudimentary state, in some of our typical mesomyodian *Passeres*, notably in *Tyrannus tyrannus*.

Through the courtesy of Mr. Frederic Lucas, I have since been enabled to dissect a fresh specimen of the Nepal Hill-Myna (*Gracula intermedia*), a sturnine bird from India. I found the *Cucullaris propatagialis* quite as rudimentary as in the *Tyrannus* alluded to. As *Gracula* undoubtedly belongs to the *Oscines*, it has been fairly demonstrated that the muscle in question is neither peculiar to the *Oscines*, nor especially characteristic of them.

In looking further into the literature, I find, also, that Fürbringer has recorded the same muscle as being rudimentary in the following oscinine birds, — *Lamprolornis insidiator*, *Pastor roseus*, *Myiagra cerulea*, *Ixos chrysoorhoeus*, *Copsychus macrurus*, and *Turdus pilaris*, — while in many others he found it but very feebly developed.

It is evident, therefore, that this variable muscular slip has no taxonomic value whatever in the direction indicated by Dr. Shufeldt. I even doubt whether it will be found of much service in defining trenchantly even families or smaller groups, since every

graduation between the rudimentary stage and the most developed condition seems to occur within the same group unquestionably nearly related birds.

LEONHARD STEJNEGER.

Smithsonian Institution, Washington, D.C.,
Dec. 20.

Answers.

ORIGIN OF FISH IN ISOLATED PONDS. — If no one else will answer Mr. C. B. Palmer's question, let me point out that nothing is simpler than that birds, lighting on the edge of first one pond, then another, should carry on their feet the eggs, larvæ, or whatever it may be, of one to the other. In digging wells in a remote desert region in Arizona, many miles from other wells, I was first surprised to find them peopled after a short time with animals (frogs, if I forget not) which could not possibly have hopped or crawled from the nearest water, across the burning sand in mid-summer, with the thermometer rising above 115° F. But I soon saw the above easy explanation.

HENRY M. HOWE.

Boston, Dec. 22.

40. FELSPAR, OR FELDSPAR? — The note on the spelling of the word "feldspar," in "Science" of Dec. 14, is satisfactory with the exception of its closing sentence, which says that the form "felspar," although wrong, had been so long employed that "no one who prefers it can be criticised for using it." It should be added to this, that all other nations except Great Britain and her colonies, and also that ninety-nine hundredths of all mineralogical literature, spell the word with the *d* (or with the substitute *t* if the language requires it), and they do so because this is etymologically right; that the English drop the letter because the error in Great Britain has been persisted in until it has become *English*; and that such national prejudice is not a legitimate ground for scientific action even in Great Britain. Years since, the writer, thinking, like many others, uniformity in scientific nomenclature very desirable, sent a short paper, giving the British history of the word, to the "London Philological Magazine," which was accepted, and published anonymously as was requested. But national prejudice proved to be superior to all other considerations. In this country the prejudice has no right to a place, and the transplanting of its effects should not be allowed without a protest.

J. D. D.

41. THE "SUPERNUMERARY MOLAR" IN MAN. — As a partial reply to Query 41 in "Science" of Dec. 7, permit me to state that Dr. Shufeldt will find in skull No. 1327, of the Morton collection in the Philadelphia Academy of Natural Sciences, the finest specimen extant of molars posterior to the third or "wisdom" teeth. It is some years since we saw it, and then "as through a glass" only; but our recollection of it is that the superior fourth molars are quite through the alveolar process, while the inferior are just seen from above in their course to the surface. The superior fourth molars are not "peg-like," but molar-like, though smaller than their neighbors. The specimen is Australian. We have a personal acquaintance who has eighteen teeth in the upper jaw; the "extra" teeth, one on each side, posterior to the third molar or "wisdom" teeth. Like Dr. Shufeldt's specimen, these are "conical, peg-like," as to form of crown. According to dental writers, the African races seem specially favored in this matter. For the best account of this structure in man (assuming it to be "supernumerary"), reference is made to the late Dr. M. S. Dean's translation of Magitot and Segros' "Dental Follicle," in which it is made to appear that the setting of an epithelial structure, and the enamel organ, determine the fact and position of the future tooth. The same process is made to account for "supernumerary" teeth elsewhere in the maxillæ, the anterior part of the upper being particularly favored. As to its significance, facts are accumulating that seem to point to the weeding-out of the third molar or "wisdom" tooth, the number and importance of the facts being directly as civilization. Such being the case, it is unreasonable to suppose this occasionally-cropping-out fourth molar other than a reversion to a past type, and to a time in the history of man when mastication was the primary, and not as now, in the civilized world at least, a secondary function?

L. E. J.

Publications received at Editor's Office, Dec. 24-29.

ABBE, C. *Treatise on Meteorological Apparatus and Methods* (Ann. Rep. Chief Sig. Off. 1887, Appendix 46). Washington, Government, 399 p. 8^c.

ADAMS, H. B. *Thomas Jefferson and the University of Virginia*. Washington, Government, 308 p. 8^c.

AYER'S Almanac, 1889. Lowell, Mass., J. C. Ayer & Co., 12^c.

DECLARATION of Independence, The, and the Constitution of the United States, in German, French, and English. Tr. by A. H. Laidlaw, Jr. New York, Laidlaw Bros. & Co., 87 p. 12^c.

ERDE, Die. Lief. 47-45. Leipzig, Hartleben, 6^c.

GROSSMANN, L. *Some Chapters on Judaism and the Science of Religion*. New York and London, Putnam, 190 p. 12^c. \$1.50.

HENSHALL, J. A. *More about the Black Bass: being a Supplement to the Book of the Black Bass*. Cincinnati, Robert Clarke & Co., 304 p. 12^c. \$1.50.

HILL, R. F. *Some Recent Aspects of Scientific Education*. Austin, Tex., The Author, 25 p. 12^c.

HINRICHS, G. *Tornadoes and Derechos*. Ann Arbor, Mich., Register Publ. Co., 28 p. 12^c.

LIEZKE, E. *Modern Geographic Processes*. New York, Van Nostrand, 143 p. 8^c.

MAYO, A. D. *Industrial Education in the South*. Washington, Government, 86 p. 8^c.

NASON, F. L. *Some New York Minerals and their Localities*. (N.Y. State, Mus. Nat. Hist., Bull. No. 4.) Albany, State, 20 p. 8^c.

NEW HAMPSHIRE, *Seventh Annual Report of the State Board of Health, for the Year ending April 30, 1888*. Manchester, State, 226 p. 8^c.

NEW JERSEY, *Final Report of the State Geologist of Vol. I. Topography, Magnetism, Climate*. Trenton, Government, 459 p. 8^c.

NEW YORK Charities Directory. 3d ed. New York, Charity Organization Soc., 524 p. 16^c.

PARIS, *Exposition de, de 1889*. No. 1. (Complete in 40 numbers.) Paris, 7, rue du Croissant, 8 p. 1^c. (New York, Christian, 10 cents.)

RÖNTGEN, R. *The Principles of Thermodynamics with Special Applications to Hot-Air, Gas, and Steam Engines*. Tr. by A. Jay DuBois, Ph.D., 2d ed. New York, Wiley, 707 p. 8^c.

TALMAGE, J. F. *First Book of Nature*. Salt Lake City, Utah, The Contributor Co., 265 p. 16^c.

WEAVER, Emily. *Dialogues and Scenes from the Writings of Harriet Beecher Stowe*. (Riverside Literature Series, No. E.) Boston and New York, Houghton, Mifflin, & Co., 96 p. 16^c. 15 cents.

Subscriptions Wanted.

A favorable arrangement will be made with a responsible person to receive subscriptions for the following first-class publications: THE ART INTERCHANGE; THE IAN UNION; THE CRITIC; DRUM; GOOD HOUSEKEEPER; PUBLIC OPINION; and SCIENCE. They appeal to every taste of education. An agency for these will afford profitable employment for responsible persons.

READING CLUBS. Those who belong to READING CLUBS contemplate forming them would do well to apply to us.

For terms address, references:

THE FORUM PUBLISHING CO.,
253 Fifth Avenue, New York.

We cordially endorse this scheme, and will add very liberal commissions for all willing to canvass for *Swiss Cross* subscriptions. N. D. C. Hodges, 47 Lafayette Place, New York.

"The Week, one of the ablest papers on the continent."—*Descriptive America*.

ENLARGED AND IMPROVED.

THE WEEK:

A Canadian Journal of Politics, Literature, Science and Arts.

PUBLISHED EVERY FRIDAY.

\$3.00 per Year. \$1.00 for Four Months.

THE WEEK has entered on its SIXTH year of publication, greatly enlarged and improved in every respect, rendering it still more worthy the cordial support of every one interested in the maintenance of a first-class literary journal.

The independence in politics and criticism which has characterized THE WEEK ever since its first issue will be rigidly maintained; and unceasing efforts will be made to improve its literary character and increase its value and attractiveness as a journal for the cultured home. Many new and able writers are now, or have promised to become, contributors to its columns, and the constant aim of the Publishers will be to make THE WEEK fully equal to the best literary journals in Britain and the United States.

As heretofore, PROF. GOLDWIN SMITH will, from time to time, contribute articles. London, Paris, Washington and Montreal letters from accomplished correspondents will appear at regular intervals. Special Ottawa Letters will appear during the sessions of Parliament.

THE WEEK in its enlarged form will be the same as "Harpers' Weekly," and the largest paper of its class on the continent.

SEND FOR FREE SAMPLE COPY.

C. BLACKETT ROBINSON, Publisher,

5 Jordan St., Toronto.

ONE LANGUAGE FOR THE WHOLE WORLD.

WORLD-ENGLISH:

THE UNIVERSAL LANGUAGE. 25 CENTS.

EVERY one has heard of the butcher who, after a long search for his knife, at last found it in his mouth: so speakers of English have been seeking for a universal language, when, lo! it is in their mouths. The intelligibility of English words has been obscured by a dense mist of letters. This is now dispersed by A. Melville Bell, who has already won a world-wide reputation through his invention of "Visible Speech," the great boon to deaf-mutes. Professor Bell calls this new discovery of his "World-English," and the result is a language which cannot fail to meet with acceptance, and at once supersede the supposed necessity for "Volapük," or any other artificial language. No language could be invented for international use that would surpass English in grammatical simplicity, and in general fitness to become the tongue of the world. It is already the mother-tongue of increasing millions in both hemispheres, and some knowledge of the language is demanded by all educated populations on the globe. Social and commercial necessities require that the acquisition of this knowledge shall be facilitated, and it is believed that Professor Bell's invention has removed the last impediment to English becoming the universal language, for which vague desires have long been entertained, although hitherto only futile efforts have been made.

Ex-President Andrew D. White, of Cornell University, says: "I believe that the highest interests of Christian civilization and of humanity would be served by its adoption. China and Japan would be made English-speaking peoples within fifty years, and so brought within the range of Christianizing and civilizing ideas, in the largest sense. All existing missionary work is trivial as compared with this. For your system would throw wide open those vast countries, as, indeed, all the countries of the world, to the whole current of English and American thought."

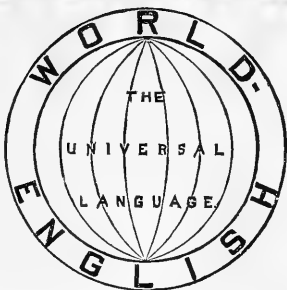

For Diffusion of English throughout the World
AS
THE UNIVERSAL LANGUAGE
This "Hand-Book of World-English" is the Complete, Simple, and Efficient Medium.
FOREIGNERS

Will Acquire, by Means of this Hand-Book, a
PERFECT PRONUNCIATION OF ENGLISH.
For Primary School Pupils and Illiterate Adults
World-English is a Royal Road to Reading.
To Teachers of English and Modern Languages
This Hand-Book will be of Primary Importance
as a Phonetic Directory.

DEFECTS OF SPEECH

Will be Readily Corrected by Means of the Articulative Directives in this Hand-Book.

HAND-BOOK OF WORLD-ENGLISH,

25 CENTS.

The plan of this little book is altogether new. Letters and sounds are so associated, in all the exercises, that from the mere knowledge of letters a learner cannot fail to pronounce words with certainty. English reading will thus be easily acquired, whether by natives or foreigners, children or adults.

The general resemblance of World-English to Literary English is such that any reader of the latter decipheres the former at sight, or, at most, after a few minutes' study of the new letters. A like result may be anticipated for those who shall learn to read from World-English. They will transfer their power of reading to the literary form of the language, almost without effort. The orthographic aspect of words will, besides, be so fixed in the eye, by contrast, that spelling will be remembered as — what it really is — a pictorial association with words.

No special training is required to qualify teachers for using this book. The subject can even be successfully introduced in the kindergarten and the nursery. This phonetic mode of initiation in reading cannot be too strongly urged on the attention of School Boards on both sides of the Atlantic.

The ordinary orthography of each word is interlined with the World-English version throughout the Exercises and Readings.

So set down, our tongue is the best for the world to unite upon.—*Brooklyn Eagle*.

The idea of Mr. Bell has much to recommend it, and the presentation is charmingly clear.—*American Phila.*
The result is a language which cannot fail to meet with acceptance.—*Boston Traveller*.

Has the merit of great ingenuity.—*Railway Age*.
His treatise, as a study of English orthoepy, condenses the result of much thought and experience in small compass.—*The Critic*.

World-English deserves the careful consideration of all serious scholars.—*Modern Language Notes*.

World-English is the English language unburdened of its chaotic spelling.—*Popular Science Monthly*.

We commend it to the attention of teachers.—*Ottawa Globe*.

"World-English" and "Hand-Book of World-English" can be had of all booksellers, or will be sent for 50 cents, post free, by the publisher,

N. D. C. HODGES, 47 Lafayette Place, New York.

DR. WARNER'S



CAMELS HAIR

HEALTH UNDERWEAR

FOR MEN WOMEN AND CHILDREN.

Superior to Silk or Wool.
A Protection against Colds, Neuralgia and Rheumatism.
SOLD BY LEADING MERCHANTS.
WARNER BROS., 359 Broadway, New York.

A Useful and Handsome Present.
Prices Reduced for the Holidays.

The Hulin Pen Fountain Pen

Warranted 14 karat gold and to give perfect satisfaction — is pronounced by hundreds of pleased customers to be the best fountain pen in the market because it is always ready. Writes freely and never gets out of order.

Sent by mail prepaid for \$1.50, \$2.00 and \$2.50 each, according to size selected.

These are special prices for the holidays, and this offer should be availed of by all who write.

JOHN S. HULIN,
Mfg Stationer and Steam Printer.
Wedding Invitations and Visiting Cards Engraved to Order.
369 BROADWAY, N. Y.
Near Franklin Street.

The Largest, Handsomest, and Most Complete Account-Book Manufactory and Printing Establishment for Fine Commercial Work in New York City.



GET THE NEW
ACME No 5
MICROSCOPE
Complete, with high-class lenses, 1 in. and 1-5 in. \$28.00.
Send for complete catalogue R, and sample of The Microscopical Bulletin.
JAMES W. QUEEN & CO.
Makers of the Acme Microscopes,
924 Chestnut St., Phila.

W. H. WALMSLEY
SUCCESSORS TO
R. & J. BECK
1016 Chestnut Street
Microscopes and Accessories and Apparatus. Photographic Apparatus. Spectacles. Glasses, Opera Marine Glasses. Illustrated Price mailed free to address. Mention Sci in corresponding with



THE ECLIPSE

One specimen so cast. Sp...
in black. No al paper, no "Eclipse" handwriting that in most ars have been ritten letters. ns on applica-



THE GREAT AMERICAN TEA COMPANY
Great... our time to get up or... our celebrated... and secure a beautiful Gold Band or Moss Rose China Tea Set, Dinner Set, or Webster's Dictionary. For full particulars address **THE GREAT AMERICAN TEA CO.,** P. O. Box 289, 81 and 83 Vesey St., New York.

TILESTON & HOLLINGSWORTH,
64 Federal Street, Boston.

Manufacturers of Fine Book Papers for letter press and cut printing. The attention of publishers and printers is called to our **Ivory Finish** (no gloss) paper. A boon to studious men, reflecting no dazzling glare injurious to the eyes. Approved and used by the best educational publishers in the country.



BRANCH AT 728 CHESTNUT ST
PHILADELPHIA, PA.

J. GRUNOW,

621 Sixth Avenue, New York.
Established 1852.

MAKER OF

Microscope Stands, Oil Immersion Objectives and Abbe Condensers for Bacterial and Histological work, of Objectives, Camera Lucida and other accessory apparatus.

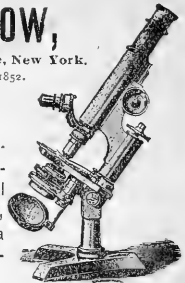

JAMES MCGREERY & CO.

Importers and Manufacturers.

SILKS, SATINS, VELVETS.

The assortment of Plain Black Silk Fabrics alone contains over 275 different weaves and qualities; of Fancy Blacks there are about 200

Send for samples of quality and style desired.

BROADWAY AND ELEVENTH ST.,
NEW YORK CITY.

Theatres.

BROADWAY THEATRE. Corner 41st St.
MANAGER..... MR. FRANK W. SANGER.
LITTLE LORD FAUNTLEROY.
Evenings at 8. Mat. Sat. at 2.

Lyceum Theatre. 4th Av. and 23d St.
Daniel Frohman..... Manager.
SWEET LAVENDER.

MADISON SQUARE THEATRE.
Mr. A. M. Palmer..... Sole Manager.
This (Wednesday) evening, Nov. 14.
PARTNERS.

PALMER'S THEATRE. E'way and 30th St.
MISS MARY ANDERSON.
Scale of prices, \$2, \$1.50, \$1, and 50 cents.

JOHN HASTINGS = Pres't.
A-R-HART = Gen. Manager.
JOS = TRIPP = V. Pres't.

ENGRAVING FOR

ALL ILLUSTRATIVE AND ADVERTISING PURPOSES

67-71 PARK PLACE
NEW YORK

SCIENCE



SEVENTH YEAR.
VOL. XIII. No. 311.

NEW YORK, JANUARY 18, 1889.

SINGLE COPIES, TEN CENTS.
\$3.50 PER YEAR, IN ADVANCE.

A Useful and Handsome Present.

Prices Reduced for the Holidays.

*The Hulin[®]
Fountain Pen*

Warranted 14 karat gold and to give perfect satisfaction — is pronounced by hundreds of pleased customers to be the best fountain pen in the market because it is always ready. Writes freely and never gets out of order.

Sent by mail prepaid for \$1.50, \$2.00 and \$2.50 each, according to size selected.

These are special prices for the holidays, and this offer should be availed of by all who write.

JOHN S. HULIN,
Mfg Stationer and Steam Printer.

Wedding Invitations and Visiting
Cards Engraved to Order.
369 BROADWAY, N. Y.
Near Franklin Street.

The Largest, Handsomest, and Most Complete
Account-Book Manufactory and Printing Estab-
lishment for Fine Commercial Work in New
York City.

ELECTRICAL TESTING BUREAU,

Johns Hopkins University, Baltimore, Md.
Resistance Coils and Boxes Compared.
Am meters and Volt meters calibrated.
Condensers standardized.
Primary and Secondary Batteries Tested.
Efficiency of Dynamos and Motors Determined.
Insulation of Cables and Wires Tested.
Circs., Etc.
Circulars describing Methods Used, Prices,
Etc., sent on Application.
Address as above.

Theatres.

BROADWAY THEATRE. Corner 41st St.
MANAGER..... Mr. FRANK W. SANGER.
LITTLE LORD FAUNTLEROY.
Evenings at 8. Mat. Sat. at 2.
LYCEUM THEATRE. 4th Av. and 23d St.
Daniel Frohman..... Manager.
SWEET LAVENDER.
MADISON SQUARE THEATRE.
Mr. A. M. Palmer..... Sole Manager.
CAPTAIN SWIFT.
PALMER'S THEATRE. B'way and 30th St.
MRS. POTTER.
Scale of prices, \$2, \$1.50, \$1, and 50 cents.

R. ELLIS & CO.

**BUSINESS, HOTEL AND PATENT BROKERS,
AUCTIONEERS, ETC.**

No. 176 BROADWAY,

Room 46.

New York.

CLIENTS ADVISED FREE OF CHARGE.

FOOD ADULTERATION

And its Detection. With photomicrographic plates and a bibliographical appendix. By J. P. Battershall, 388 pages, 8vo, cloth, \$3.50. Circulars and Catalogues on application. E. & F. N. SPON, 12 Cortlandt St., New York.

MAGIC Stereopticons and the Best Views for Public, Church, Home, and Scientific Exhibitions. Best apparatus, new views. Largest stock. Reduced prices. 24 Years' Practical Experience. Illus. Catalogue Free.
GEO. H. PIERCE,
136 S. Eleventh St., Philadelphia, Pa

ONE LANGUAGE FOR THE WHOLE WORLD.

WORLD-ENGLISH :

THE UNIVERSAL LANGUAGE. 25 CENTS.

EVERY one has heard of the butcher who, after a long search for his knife, at last found it in his mouth: so speakers of English have been seeking for a universal language, when, lo! it is in their mouths. The intelligibility of English words has been obscured by a dense mist of letters. This is now dispersed by A. Melville Bell, who has already won a world-wide reputation through his invention of "Visible Speech," the great boon to deaf-mutes. Professor Bell calls this new discovery of his "World-English," and the result is a language which cannot fail to meet with acceptance, and at once supersede the supposed necessity for "Volapuk," or any other artificial language. No language could be invented for international use that would surpass English in grammatical simplicity, and in general fitness to become the tongue of the world. It is already the mother-tongue of increasing millions in both hemispheres, and some knowledge of the language is demanded by all educated populations on the globe. Social and commercial necessities require that the acquisition of this knowledge shall be facilitated, and it is believed that Professor Bell's invention has removed the last impediment to English becoming the universal language, for which vague desires have long been entertained, although hitherto only futile efforts have been made.

Ex-President Andrew D. White, of Cornell University, says: "I believe that the highest interests of Christian civilization and of humanity would be served by its adoption. China and Japan would be made English-speaking peoples within fifty years, and so brought within the range of Christianizing and civilizing ideas, in the largest sense. All existing missionary work is trivial as compared with this. For yearsystem would throw wide open those vast countries, as, indeed, all the countries of the world, to the whole current of English and American thought."

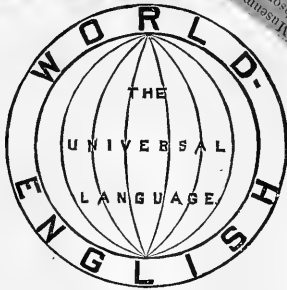

For Diffusion of English throughout the World

THE UNIVERSAL LANGUAGE

This "Hand-Book of World-English" is the Complete, Simple, and Efficient Medium.

FOREIGNERS

Will Acquire, by Means of this Hand-Book, a
PERFECT PRONUNCIATION OF ENGLISH.
For Primary School Pupils and Illiterate Adults

World-English is a Royal Road to Reading,
To Teachers of English and Modern Languages
This Hand Book will be of Primary Importance
as a Phonetic Directory.

DEFECTS OF SPEECH

Will be Readily Corrected by Means of the Articulate Direct as in this Hand-Book.

HAND-BOOK OF WORLD-ENGLISH, 25 CENTS.

The plan of this little book is altogether new. Letters and sounds are so associated, in all the exercises, that from the mere knowledge of letters a learner cannot fail to pronounce words with certainty. English reading will thus be easily acquired, whether by natives or foreigners, children or adults.

The general resemblance of World-English to Literary English is such that any reader of the latter decipheres the former at sight, or, at most, after a few minutes' study of the new letters. A like result may be anticipated for those who shall learn to read from World-English. They will transfer their power of reading to the literary form of the language, almost without effort. The orthographic aspect of words will, besides, be so fixed in the eye, by contrast, that spelling will be remembered as — what it really is — a pictorial association with words.

No special training is required to qualify teachers for using this book. The subject can even be successfully introduced in the kindergarten and the nursery. This phonetic mode of initiation in reading cannot be too strongly urged on the attention of School Boards on both sides of the Atlantic.

The ordinary orthography of each word is interlined with the World-English version throughout the Exercises and Readings.

So set down, our tongue is the best for the world to use upon. — *Brooklyn Eagle.*

The idea of Mr. Bell has much to recommend it, and the presentation is charmingly clear. — *American, Phila.*

It is a language which cannot fail to meet with acceptance. — *Boston Traveller.*

Has the merit of great ingenuity. — *Railway Age.*

His treatise, as a study of English orthoepy, condenses the result of much thought and experience in small compass. — *The Critic.*

World-English deserves the careful consideration of all serious scholars. — *Modern Language Notes.*

World-English is the English language unburdened of its chaotic spelling. — *Popular Science Monthly.*

We commend it to the attention of teachers. — *Ottawa Globe.*

"World-English" and "Hand-Book of World-English" can be had of all booksellers, or will be sent for 50 cents, post free, by the publisher.

N. D. C. HODGES, 47 Lafayette Place, New York.

GUARANTY INVESTMENT COMPANY

CAPITAL \$250,000.

Offices: Atchison, Kan. 191 Broadway, New York, 222 Walnut St., Phila.

Hon. ALBERT H. HORTON (Chief Justice, Kansas Supreme Court), Topeka, Kan., Pres't.

7% Guaranteed Farm Mortgages 7%

The Guaranty Investment Company makes loans upon fertile farms in the choicest portions of Kansas and Nebraska and has adopted the policy of sending a Committee of its Investors each year to examine its loans and methods of business.

The Committee this year consisted of PROF. A. H. BERLIN, Principal of the High School Montrose, Pa., and MAJ. THEODORE L. POOLE, Ex-U. S. Pension Agent, Syracuse, N. Y. Both of these gentlemen are persons of the highest character and have the confidence of the Communities in which they reside.

The Committee has recently returned and has made a very interesting Report upon the general development of Kansas and Nebraska as well as the business of the Company. The Company will be glad to send this Report to any address.

The following names are taken from the long list of Investors in our Mortgages:

(See if Some Friend of Yours is not in the List.)

William A. Cauldwell, 59 Liberty St., N.Y.
Palmer Cox, 658 Broadway, N.Y.
Rev. Jos. H. Eylance, D.D., 11 Livingston Place, N.Y.
Rev. Brady E. Backus, D.D., 360 West 28th St., N.Y.
Rev. R. M. Sommerville, 126 West 43th St., N.Y.
Dr. Robert A. Murray, 235 West 23d St., N.Y.
Dr. James P. Tuttle, 130 West 121st St., N.Y.
H. Edwards Kowland, 218 Fulton St., N.Y.
Irving H. Tift, Esq., 271 Broadway, N.Y.
Prof. D. C. Eaton, 55 Pineapple St., Brooklyn, N.Y.
Dr. F. P. Thwing, 150 St. Marks Ave., Brooklyn, N.Y.
Dr. C. C. Miles, Greenport, N.Y.
John V. N. Bergen, Port Jefferson, N.Y.
Benj. W. Stillwell, Yonkers, N.Y.

R. C. Coleman, Coshen, N.Y.
Mrs. Samuel Carlisle, Newburg, N.Y.
Dr. C. C. Bartholomew, Ogdensburg, N.Y.
Rev. Nelson Millard, D.D., Rochester, N.Y.
Rev. Horace G. Hinsdale, D.D., Princeton, N.J.
Dr. Charles M. Howe, Passaic, N.J.
George A. Skinner, 5 Railroad Place, Newark, N.J.
Dr. Edwin M. Howe, 85 Halsey St., Newark, N.J.
Dr. H. G. Buckingham Clayton, N.J.
Dr. Martin Cole, Jr., Hainesville, N.J.
Mortgage Trust Co. of Pa., Philadelphia, Pa.
Miss Mary Miller, 1230 Spruce St., Philadelphia, Pa.
Henry D. Biddle, 311 1/2 Walnut St., Philadelphia, Pa.

Dr. Calvin C. Halsey, Montrose, Pa.
Rev. William Baldwin, Great Bend, Pa.
Gen. William Lilly, Mauch Chunk, Pa.
Second Nat. Bank, Mauch Chunk, Pa.
Enos E. Thatcher, West Chester, Pa.
Mrs. Townsend Poore, Scranton, Pa.
Rev. Burdett Hart, D.D., New Haven, Conn.
Dr. Frank H. Wheeler, New Haven, Conn.
Charles K. Christy, Stamford, Conn.
Mrs. Catharine P. Fuller, Woodmont, Conn.
Miss Jessie Henderson, Lenox, Mass.
Dr. M. J. Halloran, Worcester, Mass.
Albert Walker, Bennington, Vt.

Address for Report and Monthly Bulletin

HENRY A. RILEY, General Eastern Manager, 191 Broadway, N.Y.

JUST PUBLISHED.

YOUNG'S General Astronomy.

A TEXT-BOOK FOR COLLEGES AND
TECHNICAL SCHOOLS.

By Charles A. Young, Ph.D., LL.D.,

PROFESSOR OF ASTRONOMY IN THE COLLEGE OF NEW
JERSEY, AND AUTHOR OF "THE SUN," ETC.

Octavo; 550 Pages; Half-Morocco; Illustrated with over 250 Cuts and Diagrams; and supplemented with the necessary Tables.

Introduction Price, \$2.25. Allowance for an old book in exchange, 40 cents.

The Eminence

of Professor Young as an original investigator in astronomy, a lecturer and writer on the subject, and an instructor of college classes, and his scrupulous care in preparing this volume, lead the publishers to present the work with the highest confidence in both its scientific value and its practical availability.

"In my opinion the best book of its class in existence."—Professor Rees, Columbia College.

GINN & COMPANY, Publishers,

BOSTON. NEW YORK. CHICAGO.

Schools.

CONNECTICUT, NEW HAVEN,

MRS. CADY'S SCHOOL FOR YOUNG LADIES.
Prepares for Smith and Wellesley, and admits to Vassar by Certificate. Circulars. Early application necessary.

VERMONT, BURLINGTON.

VERMONT EPISCOPAL INSTITUTE. Boarding School for Boys. Prepares for College or Business. Military drill. Terms moderate. Fifty-seventh half-year opens September 1888. Send for catalogue.
H. H. ROSS, A.M., Principal.

A Harvard graduate desires engagement as teacher of higher English branches, such as composition, rhetoric, literature, history, political economy, mathematics.

Address J. B. H.,

SCIENCE OFFICE.

SCHOOLS AND COLLEGES

will have a positive advantage by ordering their furniture apparatus and supplies from C. PARDO & CO.,
31 East 17th St., New York.

KNABE

PIANOFORTES.

UNEQUALLED IN

Tone, Touch, Workmanship and Durability.

WILLIAM KNABE & CO.

NEW YORK: No. 112 Fifth Av., above 16th St.
BALTIMORE: Nos. 22 and 24 E. Baltimore St.
WASHINGTON: No. 817 Market Space, Penn. Av., near 9th St.

WHITALL'S PLANISPHERES OF THE STARRY HEAVENS name and locate all Planets, Stars, and Constellations visible at any given minute of time. Every one should possess set, \$5.00; Miniature, 30 cents postage paid. Ask stationer, or address: Wm. T. Cooper, Manager, 309 Race St., Philadelphia, Pa.



KIMBALL'S
STRAIGHT CUT
CIGARETTES

Unsurpassed in quality.
Used by people of refined taste.
Highest award at Brussels, 1888.
The finest smoking mixtures are of our manufacture.
Fifteen First Prize Medals.
WM. S. KIMBALL & CO.,
Rochester, N.Y.

SCOTT'S EMULSION OF PURE COD LIVER OIL AND HYPOPHOSPHITES

Almost as Palatable as Milk.

Containing the stimulating properties of the Hypophosphites combined with the Fattening and Strengthening qualities of Cod Liver Oil, the potency of both being largely increased.

A Remedy for Consumption.
For Wasting in Children.
For Scrofulous Affections.
For Anemia and Debility.
For Coughs, Colds & Throat Affections.

In fact, ALL diseases where there is an inflammation of the Throat and Lungs, a WASTING OF THE FLESH, and a WANT OF NERVE POWER, nothing in the world equals this palatable Emulsion.

SOLD BY ALL DRUGGISTS.

SCIENCE

FRIDAY, JANUARY 18, 1889.

THE WHITE ELEVATED ELECTRIC RAILROAD.

THE crowded state of the streets of our great cities, and the increasing necessity of greater facilities for travelling safely through them with speed and comfort, have brought to the front many devices for solving the problem of rapid transit. One of the most recent of these is the elevated railroad lately invented by Mr. R.

which are only called into play in case of an undue oscillating or rocking motion of the car resulting from obstructions or too great speed, are safeguards against the car leaving the track. They also enable the car to pass around curves of short radii at a reasonable speed without danger of derailment.

The plan and cross-section of a box girder for supporting the main bearing rail is shown in Fig. 1. This is only one of many methods which may be used for sustaining the weights of heavy trains at high speeds; another support, shown in Fig. 2, being an I

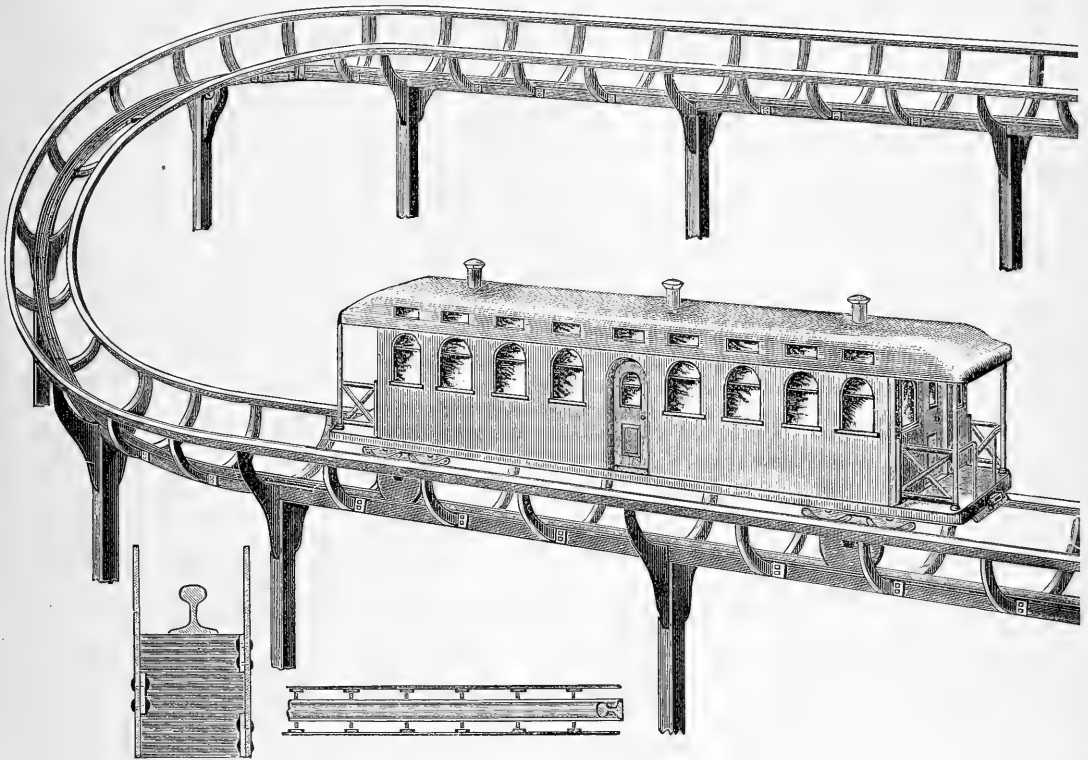

FIG. 1.—THE WHITE ELEVATED RAILROAD.

T. White of Boston, of which we present herewith two illustrations; one being a general view of a car, with a section of the roadway, including a short curve, and the other showing some details of the truck and track. In his elevated railway system, Mr. White has embodied the results of much railroad experience and many interesting experiments. As may be seen in the illustration (Fig. 1), the track is supported by a single line of columns. The car rests upon two wheels (one at each end), instead of upon eight (four at each end), as in the ordinary passenger-car. The car is steadied horizontally by eight guide-wheels (four at each end), assisted by small rollers, one projecting from beneath each guide-wheel (Fig. 2), and having an upward bearing against the side-rails, which form the horizontal guides for the car-trucks. These guide-rollers,

beam resting upon the columns. Trusses of various forms may also be used; the method of support, as well as the height and distance apart of the supporting columns, being determined by the varying local conditions.

One difficult problem in the perfecting of this system of road was that of switching; but Mr. White claims to have not only solved the problem, but to have made the arrangement of the switch such that the track is never open, even should the switch be turned the wrong way, as the bearing-wheels can never leave the supporting-rail, and consequently the car cannot leave the track.

This system of elevated railroad, though intended primarily for an electric road, may use steam or cables. As yet, we believe, there is no road in operation constructed upon Mr. White's system,

though large working models show the feasibility of not only running trains upon such a track by any of the motive powers men-

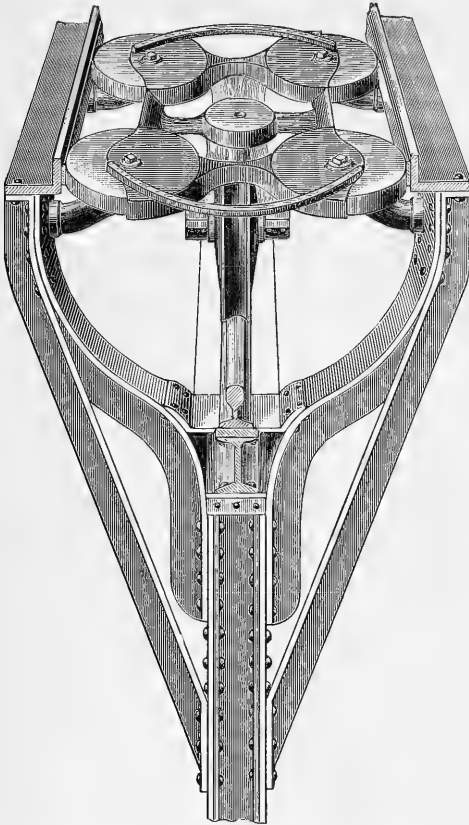

FIG. 2.—THE GUIDE-WHEELS OF THE WHITE RAILROAD.

tioned, but also of running them safely around short curves and at high speeds.

ELECTRICAL NEWS.

Light without Heat.

PROFESSOR BRACKETT of Princeton College delivered an interesting address before the New York Electric Club some weeks ago. The part of his lecture which treated of the production of light without heat gave an admirable summary of Dr. Hertz's experiments on electro-magnetic waves, and afterwards Professor Brackett indicated the lines on which he thought it would be best to experiment to obtain practical results. Briefly the state of the case is this: light consists of electro-magnetic vibrations of a definite and very short period. In our ordinary methods of artificial illumination we produce vibrations of a period that will affect the eye, by heating particles to incandescence, the resultant vibrations being of a great number of periods, only a few of them being of use for illumination. In fact, a great deal of energy is wasted, only a very small proportion of the total appearing in a form that is useful to us. Now, the problem that is presented is to produce vibrations of the period we want, and no other; and the problem is a very difficult one to solve. In nature there are phosphorescent substances and certain insects—glow-worms, fire-flies, etc.—which are very efficient illuminants, the light produced

being accompanied by very little heat: so the problem is not impossible, and we may regard it hopefully. The most serious difficulty lies in the extreme rapidity of the oscillations required, billions of them a second,—a rapidity so great that it seems impossible to attain it by any mechanical means. Nor would it be possible to economically distribute the vibrations when they were produced.

Professor Brackett proposes to solve the problem by working it backwards, to take a beam of light, polarize it so that all of its vibrations are in one plane, and "harness that to a wire, so that it will make a current vibrate and also make the magnetic field about the wire vibrate: in other words, if you cannot do the sum, take the answer and work backwards. That is what I intend to do, and I will hint to you exactly how I propose to do it. It cannot be done with the ordinary materials employed for conductors, if it has to heat the wire. . . . We must get something that is not a conductor in the ordinary sense. I remind you that the amount of energy expended in the movement in the high vacuum tube, in the ordinary tube, where you have the most beautiful illuminations, is, in matter of fact, very small. . . . I point out to you next that there is one substance in which we have the properties of both the conductor and the non-conductor present, and there are some very hopeful indications in that. A selenium cell, which is semi-transparent, when it is joined up and a battery current is put through it, is found to have its resistance diminished immediately a flash of light falls on it. . . . Suppose we take a polarizing apparatus by which we can polarize a long web of light. It will consist of vibrations all sorted out in parallel planes by themselves. . . . Now let this polarized web of light be passed through a narrow slit so as to pass directly upon or near the conductor in which we wish to set up an alternating electric current. If the proper conductor can be found, it should have the current set up in it, and this should produce a magnetic field about it. . . . What we want is an alternating current or discharge of some sort or other, which shall enable us to produce the alternations with such frequency that the so-called conductors will break out and shine directly. . . . A dynamometer ought to be constructed which would be capable of measuring the effect. But with the ordinary opaque conductor, such frequency means confusion among the molecules, which brings about a difficulty. That is what we must get rid of."

In a subject like this, which is certain to command the attention of investigators and inventors, which gives so much promise, and in which there seems no impossibility, it is well to keep abreast of even the suggested solutions. Professor Brackett's plan seems to be to transmit light from places where the sun is shining, to other places where it is not. But it is hard to see how this plan can work successfully. Vibrations of such rapidity as those of light-waves cannot be transmitted along a conductor, for conductors would offer a practically infinite resistance to currents of such a period. They are transmitted through a dielectric simply as light; and the fact that we believe light to be an electro-magnetic disturbance does not help us to solve the problem. The transmission of light as such stands just where it did before Hertz's experiments or Maxwell's theory were published. The efficiency of transmission of the waves, however they are transmitted, is much greater as the period is increased. A wave of a period some millions of times less than that of light might be transmitted from China here without much loss, provided we did it properly, while the energy of a light-wave would be dissipated before it had gone a mile. If we wish to transmit light, we must reduce the vibrations to a greater period at the sending station, and raise them again at the receiving end; and this will be difficult. If we wish to produce light, we have little encouragement in the line of producing an electric wave of the required period by mechanical means. The period of vibration of a charge of electricity, displaced on the surface of a sphere of a centimetre radius, might be a thousand million a second; but to reach the millions of millions necessary for light, the size of the sphere would have to be decreased until it had reached molecular proportions. We have in nature, however, instances of the kind of action we wish. In glow-worms and fire-flies the results we are attempting to attain are reached, and we need not despair of a problem the solution of which is called to our attention on almost any

summer's night. But the line sketched out by Professor Brackett offers, we think, only a very slender hope of accomplishment.

NEW SECONDARY BATTERIES. — Hardly a week passes but we read of some new secondary battery that is to be introduced. This state of affairs has a promising side and an unpromising one. It shows the great need of some reliable storage-battery, and it brings out the fact that a great number of people are working at the problem of finding one. Some of these new cells compare very favorably with the older and better-known types; some of them are, in all probability, not so good. One of the newest is the Johnson battery, which is to be manufactured in Boston. Special advantages are claimed for it, but no figures are given, nor is it anywhere fully described. Two other batteries have been recently put on the market, — the Macrean and the Detroit. We hope to publish some figures as to the latter at an early date: it is a promising type of cell. It is to be hoped that a year which opens with such activity in storage-battery circles will develop some cell that will make electric traction in our crowded cities practicable.

IS A VACUUM AN ELECTRIC CONDUCTOR? — Some time ago M. Foepll made some interesting experiments on the conductivity of a vacuum; his results tending to show that a vacuum is an insulator, or, at best, its conducting-power is very small. The experiment has been described in this journal. Briefly it consisted in making a galvanometer whose coils were made of glass tubing from which the air had been exhausted, and connecting it with the secondary of an induction-coil, also constructed of glass tubing. There was no inductive effect observed when a current was sent through the primary of the coil, even when the electro-motive force induced had a value of 5,000 volts. M. Foepll concluded then that an absolute vacuum would be a non-conductor, and that ordinary vacuum-tube phenomena are caused by convection. Some of his more recent experiments tend to throw some doubt on these conclusions. He placed an exhausted tube within a solenoid through which he sent a Leyden jar discharge. Luminous phenomena took place, as in an ordinary vacuum tube provided with electrodes, at which an electro-motive force is applied. We know so little, however, of the nature of luminous discharges in vacua, that we can hardly consider the evidence of the last experiment so strong as that of the first; and while it may be possible to account for either result on the hypothesis of the non-conduction, or on that of the conduction of a vacuum, the former seems much the more probable.

ELECTRIC LIGHT IN THE PATENT OFFICE. — From the report of the secretary of the interior, we learn that arrangements were made the past year with the assistance of Lieut.-Commander Bradford of the United States Navy (among the most expert of electricians), with the Brush Electric Light Company of Cleveland, O., for the construction of the necessary machinery, and the arrangement of wires, appliances, and lamps, for the Patent Office building, in order to light it completely. The department will be able to furnish its own light at so great a diminished cost, that it is believed the saving from the average annual outlay heretofore sustained will in three years reimburse the expenditure for the plant. There are such vast piles of public papers, records, and documents in the various rooms, halls, and cellars of the department, many of these so dark as to require light throughout the day, that a mode of illumination which is consistent with their safety becomes of prime importance. It is believed that this object has been most satisfactorily secured by the arrangements made under the direction of Lieut.-Commander Bradford. Secretary Vilas avails himself of the opportunity to express his sense of obligation for the great advantage enjoyed in the generous contribution of Lieut.-Commander Bradford's expert and valuable knowledge, from which he believes the electrical equipment of the department will hardly be equalled in the country for safety and efficiency, procured upon the most economical terms.

PROFESSOR N. S. SHALER of Harvard University is in Washington, on his way to the Dismal Swamp. He will there spend a fortnight in geographical and geological researches, in order to complete an article for the next annual report of the Geological Survey.

THE OBSERVATORY HILL RAILWAY OF ALLEGHENY CITY, PENN.

THIS railway has been in continuous operation since January, 1888, as an electric road. The line is about four miles in length. For one-fourth of this distance the electric conductors are contained in a sub-surface conduit. For the remainder of the line the conductors are elevated above the roadway, being bracketed off from poles erected along one side of the street. The conduit branches from double to single track, and at the present terminus of the line there is a conduit cross-over switch from down to up track. At different points along the conduit section the conduit cuts through five other street-railway tracks belonging to other companies.

On the elevated conductor section the line is single track with seven turn-outs. Double conductors are used throughout both conduit and elevated conductor sections, neither the rails nor any part of the conduit itself being used as a part of the electric circuit.

Nowhere throughout the whole line is there a space fifty feet long where a car will stand without the brakes being applied. There are thirty-four curves on the line, not including turn-outs or switches. The maximum grade is 12½ feet in 100 feet. There is a total rise of 295 feet in 4,900 feet, with an average of about six per cent. The maximum grade of 12½ is on a reversed curve (radii 100 and 200 feet). The sharpest curve has a 35-foot radius on five-per cent grade.

The Bentley-Knight conduit system consists of a power station, — engines, boilers, and dynamo-electric machines; a conduit running the whole length of the line, containing the conductors which convey the electric current to the motors; and hanging connections (ploughs) which pass through the conduit slot, and, sliding along the conductors, maintain unbroken connection between the motors and the source of power. The electric conductors are accessible only to regular employees, furnished with special tools, while the current used, even in roads of the heaviest carrying capacity, cannot injure either life or property.

The conduit, which contains the conductors and supplies the current to the motors along the line, can be placed at any point where the opening of the slot will be below any part of the car-body. In constructing a conduit line, the iron yokes shown in the accompanying figure are set up from four to six feet apart, and the conductors set against the insulators which support them at each yoke. The electrical connection between the different lengths of conductor are then made, the slot-steels set on the yokes, and the slot-steels and yokes firmly bolted together, leaving a slot opening at the surface of the street of only five-eighths of an inch. Attention is especially directed to that form of Bentley-Knight conduit which permits the width of the slot to be regulated, the slot rails to be removed, and the conductors, insulators, and interior of the conduit to be inspected, without disturbing the pavement. The conductors are copper bars connected by expansion joints, and are of sufficient size to carry the current with a loss never greater than five per cent. The fact that the conduit can swerve from a straight line to avoid obstructions, and can be laid outside of the track wherever desired, greatly decreases the expense and difficulty of laying.

Electrical connection between the motor and the conductors in the conduit is effected by a contact-plough, which consists of a flat frame, hung from the car by transverse guides (on which it is free to slide the whole width of the car), and extending thence down through the slot of the conduit. It is so constructed as to adjust itself to all inequalities of road or conduit. This frame carries two flat insulated conductor-cores, to the lower ends of which are attached, by spring hinges, small contact-shoes, which slide along in contact with the two conductors in the conduit. At the upper ends are attached connections leading to the motor. This plough can be inserted or withdrawn through the slot at will, the spring hinges allowing the contact-shoes to straighten out into line with the conductor-cores when the plough is pulled upward. By no accident, therefore, can any thing be left behind in the conduit to obstruct succeeding cars. The plough-guides are hung on transverse axes, and are held in a vertical position by a spring-catch that gives way when the plough meets an irremovable obstruction, and allowing the plough to be thrown completely out of the conduit without injury, it being also immediately replaceable. The frame of the

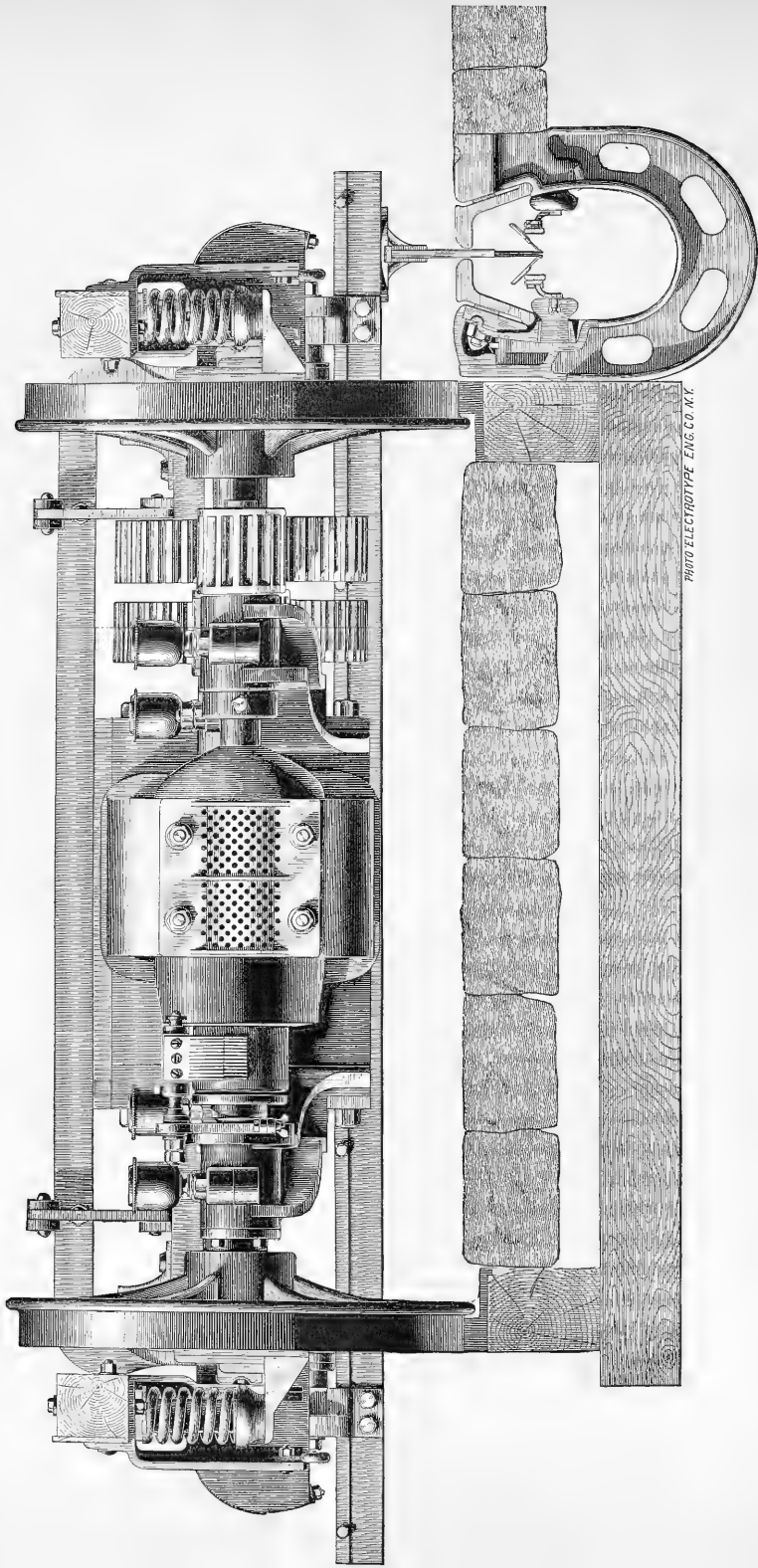
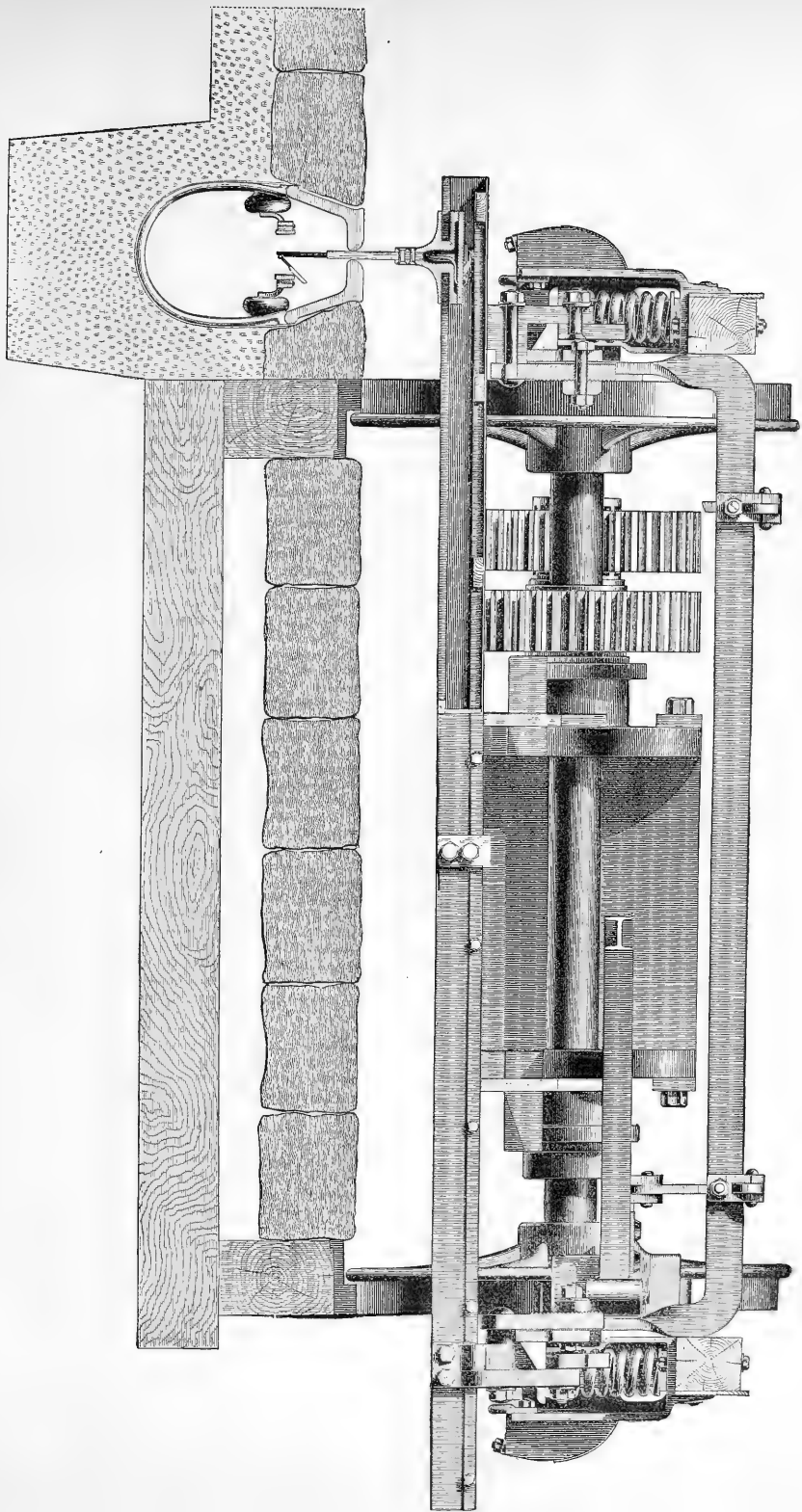

PHOTO ELECTROTYPED ENG. CO. N.Y.

BENTLEY-KNIGHT STANDARD MOTOR TRUCK, CONDUIT, AND PLOUGH (FRONT VIEW).



BENTLEY-KNIGHT STANDARD MOTOR TRUCK, CONDUIT, AND PLOUGH (REAR VIEW).

plough has wearing guards of hardened steel wherever it can touch the edge of the conduit slot; and the shoes are made of soft metal, which takes up all the wear and prevents any injury to the conductors. Two ploughs are used on each car for the sake of absolute reliability.

For suburban lines, or for small cities where the traffic does not justify the employment of the more expensive conduit system, the company furnishes its elevated conductor system. The elevated conductors can be either bracketed off from poles, or hung from wires crossing the street at any desired height above the roadway. Electrical connection between the motor on the car and the elevated conductors is maintained by means of a trolley or contact-brush and a flexible conductor.

The motor and mechanism of a car operate noiselessly, and are entirely concealed from view beneath the bottom of the car. Cars may be stopped as quickly as desired, may reverse at will, and, if derailed, can propel themselves back on the track.

The motor is controlled from either end of the car; and the driver may proceed at any speed, from a slow creep to that of twenty miles an hour.

SCIENTIFIC NEWS IN WASHINGTON.

The Archæology of the District of Columbia. — Our Future Empire. — Science and Psychos.

The Archæology of the District of Columbia.

THE Anthropological Society of Washington consists of four sections, each in charge of a vice-president, but none thus far definitely organized: viz., Section A, somatology; Section B, sociology; Section C, philology, physiology, and psychology; Section D, technology. It has of late become apparent to members interested in archæology (which is included in the last section) that this subject has received inadequate attention during the past year or two, and especially that too little attention has been given to the archæology of the District of Columbia and contiguous territory. In order to strengthen this branch of anthropology, and at the same time to stimulate local investigators, a temporary organization of Section D has been effected. At a meeting of the members of the society interested in local work, called by the vice-president of the section, Dr. O. T. Mason, last week, it was decided to combine efforts and results, with the immediate object of elucidating the history of the aboriginal inhabitants of the Potomac River as recorded in relics and early writings, and with the ultimate object of preparing and publishing a monograph on the antiquities of the District of Columbia. A committee was appointed to prepare *résumés* of existing knowledge on various phases of the subject for presentation at one of the meetings of the society in April next. This committee, which has power to add to its numbers, is as follows: geology in its relations to early man, W. J. McGee of the United States Geological Survey; paleolithic man and his remains, Thomas Wilson, curator of antiquities of the Smithsonian Institution; relics of the later aborigines, S. V. Proudfit of the Interior Department; prehistoric settlements and workshops, Dr. Elmer R. Reynolds of the Pension Office; aboriginal tribes recorded by early explorers, James Mooney of the Bureau of Ethnology.

Our Future Empire.

The event of the sixteenth regular meeting of the National Geographic Society on the 11th inst. was the presentation of an elaborate paper on "The Great Plains of Canada," by Mr. C. A. Kenaston. During several seasons of constant exploration, undertaken with the object of ascertaining the agricultural, pastoral, and other capabilities of the country, Mr. Kenaston became thoroughly acquainted with the vast expanse of plain country stretching from Hudson Bay to the foot-hills of the Rockies, and from the international boundary to the Arctic Circle. The entire tract is one uninterrupted, monotonous, grassy plain, sloping gently to the eastward and northward, diversified only by shallow lakes and broad water-ways in the east, and by shallow but steep-sided cañons of the rivers beginning in the mountains in its central and western portions. The general hydrography, the more detailed topographic features, the flora, the fauna, and the *voyageurs* of the Hudson Bay Company, — the link connecting the aborigines with the white in-

vaders who now possess the land, — were all described at length; and it was pointed out that this region, long the home of the buffalo, the wolf, the badger, and uncounted myriads of wild fowl, is the American wheat-field of the future. In the south-eastern portion of the tract the soil is a dark prairie loam, like that of Minnesota and Iowa; west and north-west of it lie millions of acres of "gumbo" soil, refractory under the first efforts of the agriculturist, but made fruitful by two or three seasons of tillage; while the soil of the northern plains is a fertile yellow loam or bowlder drift; and over twenty millions of acres the conditions of soil and climate are alike so favorable to wheat-growing, that only peopling by farmers and the opening of transportation routes are needed to make any part of it successfully rival the famous wheat-fields of Minnesota and Dakota. Already the tract is intersected by the Canadian Pacific and many other railways, the navigable rivers are being supplied with steam-craft, and the lands along railways and water-ways are generally sectionized and open to occupation; and the present prospects are that this northern expansion of the Great Plains of America will be overrun by settlement nearly as rapidly as was the part drained by the Mississippi and its tributaries.

Science and Psychos.

On Friday evening last, some thirty or forty scientific men assembled at the residence of Mr. W. A. Croffut, to "assist" at some experiments in hypnotism by that gentleman. Among those present were Professor N. S. Shaler, G. K. Gilbert, Dr. T. N. Gills, A. H. Thompson, W. C. Winrock, Col. Garrick Mallory, Gen. Adam Badeau, Major Powell, and Mr. F. M. Thorn, chief of the Coast Survey, besides several members of Congress. While one of the hypnotized sensitives was personating an aged colored preacher, he was violently seized by Major Powell, denounced as an impostor, and thrust out of the room. He seemed unconscious of the strange interruption, and the stream of his exhortation flowed on unbroken to the end, until Mr. Croffut appeared and recalled him from the trance. Major Powell then made some remarks on hypnotism and the relation of its hallucinations to other states, especially to mental abstraction and heterophemy, and the desirableness of subjecting its phenomena to scientific conditions and observation.

CENSUS OF THE DEFECTIVE CLASSES.

At the suggestion of Senator Eugene Hale, chairman of the census committee of the United States Senate, Professor A. Graham Bell addressed a letter to the committee, in which he refers to some of the results of the census of 1880, especially with reference to the relative increase of the deaf, the blind, the idiotic, and the insane within recent years, as compared with the population in the United States, and to deafness as caused by the marriage of the deaf with the deaf, and makes some suggestions as to the taking of the next census. As this communication is of considerable importance at the present time, when preparations are being made for the next census, we reproduce it here *in extenso*.

According to the census returns, the defective classes have increased 400 per cent in thirty years, while the general population of the country has simply doubled. The following table shows the relative figures at each census since 1850: —

Years.	Total Population of the United States.	Total Blind Population.	Total Deaf-and-Dumb Population.	Total Idiiotic Population.	Total Insane Population.
1850.....	23,791,876	9,794	9,803	15,787	15,610
1860.....	31,443,321	12,658	12,821	18,930	24,042
1870.....	38,553,371	20,320	16,205	24,527	37,432
1880.....	50,455,783	48,928	33,878	76,895	91,997

I have examined with care the statistics of the Tenth Census relating to the deaf-and-dumb, and find internal evidence to show that in their case there has been a real increase greater than the increase of the general population, and not simply an apparent

increase due to greater accuracy of enumeration: for, when the whole population of the United States are classified according to their age in 1880, the proportion of deaf-mutes among the younger persons is seen to be greater than among the older; indeed, it is proportionally greater as the age is younger, until quite young children are reached.

The following are the number of the deaf-and-dumb returned in the Tenth Census:—

Period when Deafness occurred.	Number of Deaf-Mutes.
At or before birth.....	12,155
After birth.....	10,318
Not stated.....	11,405
Total.....	33,878

Classification of these cases according to their age in 1880 shows that there has been an enormous increase of recent years in the numbers of the non-congenitally deaf; but this need hardly be considered as a permanent condition, for it appears to be due to an epidemic of cerebro-spinal meningitis, which will probably die away, as former epidemics have done.

The following table shows the percentage of the whole population of the United States born at each decade, and also the percentage of the congenitally deaf population:—

Period of Birth.	Total Population Living in 1880.	Congenital Deaf-Mutes Living in 1880.	Percentage of the whole Population Living in 1880.	Percentage of Congenitally Deaf Population Living in 1880.
Before 1780.....	4,016	—	0.0080	—
1781-90.....	20,863	9	0.0416	0.074
1791-1800.....	196,197	63	0.3912	0.518
1801-10.....	776,507	241	1.5482	1.983
1811-20.....	1,830,095	472	3.6488	3.883
1821-30.....	3,111,317	751	6.2033	6.179
1831-40.....	4,558,256	1,078	9.0882	8.870
1841-50.....	6,359,362	1,614	12.6992	13.280
1851-60.....	9,168,393	2,460	18.2798	20.240
1861-70.....	10,726,601	3,398	21.3866	27.958
1871-80.....	13,394,176	2,068	26.7051	17.015
Total.....	50,155,783	12,154	100.0000	100.000

These results are shown in graphical form in the following diagram. The continuous line indicates the percentage of the general population, and the broken line that of the congenitally deaf population, born at each decade.

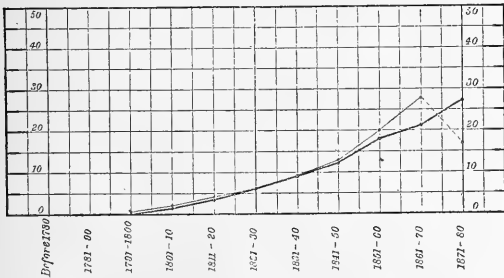

The indications are that the congenital deaf-mutes of the country are increasing at a greater rate than the general population.

The great and sudden decrease in the numbers of deaf children born in the last decade (1871-80) is probably due to imperfect returns of deaf-mutes under ten years of age: for, though 54 per cent of all the deaf-and-dumb were deaf from birth, only 30 deaf infants were reported in the census of 1880, and only 49 between the ages of one and two, out of a total deaf-mute population of 33,878.

Statistics in my possession show that in the year 1819 deaf-mutes began to marry partners who were themselves deaf-and-dumb.

The percentage of intermarriages has continuously increased, until now not less than 90 per cent of all deaf-mutes who marry, marry partners who are themselves deaf-and-dumb.

The latest statistics collected by me include 1,443 cases of marriage. Of these 1,443 deaf-mutes, I find that 71 (or 5 per cent) had married hearing persons, and 1,372 (or 95 per cent) had intermarried among themselves.

In 1828 a deaf-mute child was born of a deaf-mute father and mother, and now such cases can be numbered by the hundred. My statistics are based upon a list of 528 deaf-mutes, mostly young, who have one or both parents deaf.

Some of these children have already married deaf husbands or wives, and deaf offspring have appeared in the third generation.

I can cite families in which the deafness has been handed down through four generations, and can give in minute detail particulars relating to a family in Maine in which congenital deaf-mutes have appeared for five successive generations in increasing numbers, and in which the younger deaf-mutes are marrying deaf-mutes.

My list of deaf children of deaf parents (all, excepting one, born before 1880) comprises 528 cases (mostly young), 91.6 of whom were deaf from birth.

Upon the assumption that 528 such cases were living when the Tenth Census was taken, we obtain the following results: 1. One person in every 1,480 of the general population was deaf-and-dumb, and one person in every 64 of the deaf-mute population was a child of deaf-mute parents; 2. One person in every 2,736 of the general population was deaf from birth, and one person in every 38 of the congenitally deaf population was a child of deaf-mute parents.

The laws of heredity indicate, that, if these deaf children should marry congenitally deaf husbands or wives, an increased proportion of deaf offspring will appear in the next generation; and that the continuous intermarriage of congenital deaf-mutes from generation to generation may ultimately result in the formation of a deaf variety of the human race in America, in which all or most of the children will be born deaf.

In these conclusions I am supported by the following American men of science, all members of the National Academy of Sciences, and most of these experts on the subject of heredity. These gentlemen are Professor Edward D. Cope, editor of the *American Naturalist*; Professor Alpheus Hyatt of Harvard University; Professor William H. Brewer of Yale University; Dr. Bowditch of Harvard University; Professor Simon Newcomb of Washington, D.C.; and Professor W. K. Brooks of Johns Hopkins University.

I would therefore urge upon the United States the importance of examining in the next census the marital relations of defective persons, and the extent to which their defects have been inherited by their offspring.

The enumeration of the defective classes is always found to be itself defective.

However perfect the classification may be, the returns of these classes will always be incomplete, on account of a natural objection to expose the defects of relatives, especially when these are very young.

Accuracy of enumeration will be promoted by eliminating from the census schedules (as far as may be possible) every question that could wound the feelings of parents or friends of afflicted persons. For example: if the enumerator approached the subject of defects by asking whether the persons enumerated were perfect in sight, hearing, mind, and body, he would be more likely to secure the information desired than if he asked a fond mother whether her child was "blind, deaf-and-dumb, idiotic, insane, maimed, crippled, bedridden, or otherwise disabled."

There are degrees in every defect, and the lesser forms are more

capable of amelioration than the graver. Classification under the graver forms tends to the exclusion of the lesser from the returns; but classification under the lesser forms would include the graver, and be less objectionable to friends, so that evasions would be fewer, and the returns more accurate and complete. For example: the blind, deaf-and-dumb, idiotic, insane, maimed, crippled, bed-ridden, and otherwise disabled, would all be returned under the head of defects in sight, hearing, mind, or body; but the converse would not necessarily be true.

The returns should include all persons laboring under disabilities of sight, hearing, mind, or body, of sufficient magnitude to prevent education in ordinary schools, lessen wealth-producing power, and incapacitate for military service.

The deaf and the blind should be grouped into a sub-class by themselves, and separated as much as possible from the other defective classes, because they are enumerated chiefly for educational purposes, whereas the others need eleemosynary care or restraint.

Public establishments for purely educational purposes should be classified as "schools," and not as "asylums." They should be included in statistics relating to the general education of the people, and excluded from those relating to charitable institutions.

Many children who cannot profitably attend ordinary public schools on account of disabilities are allowed to grow up without instruction, because parents object to send them to asylums, or institutions governed by State boards of charity.

The statistics of the Tenth Census show the following figures relating to defective children of school age (six years and under twenty-one):—

	Total in the United States.	Total in Special Schools.
Blind.....	7,768	5,534
Deaf-and-dumb.....	15,059	4,893
Idiotic.....	29,373	1,942
Insane.....	3,184	—

The term "deaf-and-dumb" is not only objectionable in itself but is incorrect, because it classifies those who belong to this class as laboring under a double disability instead of a single one.

Deaf-mutes are simply persons who are deaf from childhood; and dumbness or muteness is the result of the natural defect, and not a defect in itself. The vocal organs are not defective.

Many of the so-called deaf-and-dumb can speak. Some had acquired the art before hearing was lost, and others acquired it by instruction in school.

In the census of 1880 all persons who lost hearing before they reached the age of sixteen years are classified as "deaf-and-dumb," whether they can speak or not.

This incorrect and very objectionable classification leads to evasion and inaccurate returns.

Dumbness by itself is not a defect calling for enumeration in the census (unless, indeed, for statistical purposes and the determination of causes), for defective speech alone is not a disability that prevents instruction in ordinary schools. It does not materially lessen wealth-producing power, nor does it incapacitate the person for military service.

Persons who have not studied the subject generally fail to realize that deaf-mutes should be classified among the deaf, and not among the dumb; and enumerators, therefore, can hardly be expected to follow the classification.

For the sake of accuracy in the returns, therefore, it would be well to make defective speech a subject of inquiry in the primary schedule relating to population. The dumb who are deaf, and the dumb who are idiotic, will appear on supplementary schedules relating to the deaf or the feeble-minded; and the dumb who are neither deficient in mind nor hearing need have no special schedule of inquiry.

Special schedules relating to all the defective classes (except the dumb) should be prepared with the assistance of experts of two kinds; viz., specialists who have studied the causes of the defects,

and teachers who are familiar with the special methods of instruction necessary.

The gravity of the disabilities resulting from deafness can be ascertained from two elements: (1) the age or period of life at which the defect occurred; and (2) the amount of deafness (whether total or partial). The former element is the more important of the two, for a slight defect of hearing in an infant results in graver disabilities than total deafness occurring in adult life. For example: in the case of the deaf infant, the defect interferes with the acquisition of language through the ear, and the child remains dumb. His thoughts are carried on without words, so that a mental condition exists which is abnormal. His ignorance is so great as to be appalling; for his mind is deprived of every thing that other people have ever heard of or read about that is not derived directly from their own observation. Without special instruction, such children grow to adult life with all the passions of men and women, but without the restraining influences that spring from a cultivated understanding.

Persons who become deaf in adult life have no greater disability than the defect itself; but, where deafness occurs in childhood, incidental disabilities arise which are greater than the natural defect; but because they are incidental, and not natural, they are capable of amelioration, and even complete removal, by suitable instruction in special schools. Hence the very great importance of a correct enumeration of the young deaf children.

In the primary schedule relating to population the defective classes should be grouped together under the head of "physical and mental condition," instead of under "health," as was done in 1880. The following form is suggested for incorporation in the primary schedule relating to population:—

PHYSICAL AND MENTAL CONDITION.						
CONDITION OF—						
Sight.	Hearing.	Speech (of persons 5 or more years of age.)	The Mind.		The Body.	
			Mental Development.	Mental Health.	Bodily Condition.	Bodily Health.

Is the person [on the day of the enumerator's visit] sick or temporarily disabled, so as to be unable to attend to ordinary business or duties?
If so, what is the sickness or disability?

The enumerator should be instructed to ask whether the person has perfectly normal sight, hearing, and speech; whether the mind is normally developed and in a healthy condition; and whether the bodily condition is normal and the general health good. If the answer is "yes," the enumerator should indicate the reply by a horizontal mark (—) placed in the proper column; if "no," by a mark sloping from right to left (/); and, if the question is not answered in a satisfactory and reliable manner, the column should be left blank. If the physical or mental condition is reported as "not perfectly normal" (/), the enumerator should then inquire whether the disability is sufficiently great to prevent instruction in an ordinary school, to interfere with the acquisition of a suitable means of livelihood, and to incapacitate for military service. If the answer is "yes," he should change the negative mark (/) into a cross (x), and proceed to put the interrogatories contained in the supplementary schedule relating to the special class of defect noted.

As the supplementary schedules should be prepared with the assistance of specialists, it may perhaps not be advisable for me at the present time to refer to the details, excepting so far as to say that inquiries should be instituted relating to the causes of defects and their inheritance by offspring. The marital relations of defective persons should be noted and the results tabulated. The total number of children born to them should be recorded, and the number who died young. The record should also note the number of defective and normal offspring.

In examining the ancestry of deaf-mutes, I have had occasion to consult the original population schedules of former censuses, which are preserved in the Department of the Interior; and I have found little difficulty in tracing the families backward from census to census in the male line of ascent. If the name of the father had been given in former censuses, it might now be possible for genealogical experts to trace from these records the American ancestry of every person now living in the United States in every branch, for the name of the father would give the maiden name of females. I therefore suggest that in the census of 1890 the father's name should be noted in that part of the schedule that relates to the nativity of the parents, so that the people of the United States may leave to their descendants genealogical records from which their full ancestry may at any future time be ascertained.

MENTAL SCIENCE.

Negative Suggestions.

THE meaning of this term as applied to certain hypnotic phenomena has become quite familiar. It refers to the ignoring by the subject of a portion of his sensory experience. If told that upon awakening a certain person will be absent from the room, such a person may stand directly before him, and he will be entirely ignorant of his presence. Dr. Bernheim, in studying the details of this phenomenon (*Revue de l'hypnotisme*, December, 1888), regards the condition as of purely psychic character. The defect is not physiological. The eye sees, for the subject will not run against the "invisible" person, but the brain ignores the impressions made upon it. It refuses them a hearing. This point, that in this condition the perceptions are really present but are not allowed admittance into consciousness, Dr. Bernheim proposes to demonstrate. He tells an apt subject in the hypnotic state that on her awakening he will be gone. She is awakened, searches about, but gives no sign of recognizing Dr. Bernheim. The latter speaks to her, shouts into her ear, sticks a pin into her skin, even touches her eye with it, but all with no response. She is oblivious to all impressions coming from him. If some one else touches her with a pin, she withdraws her hand at once. To do this, she must distinguish Dr. Bernheim from the other spectators; and this involves sight.

It should be noted that this experiment will not always have the same result. If told that they will not see Dr. Bernheim, some subjects will not see him, but will hear him and feel his touch, — a condition causing them a good deal of surprise, and often leading them to infer that another person must be speaking to them, and so on. By suggesting in detail that the doctor will neither be seen, heard, nor felt, a complete anæsthesia can be established.

Returning to the former subject, Dr. Bernheim, while invisible, spoke abusive words to her; but her face betrayed no emotion. Thereupon she was hypnotized by an assistant, and given the suggestion that upon her re-awakening the doctor would again be present. Dr. Bernheim then asked what he had said to her. She denied his having been present; but he insisted, impressing upon her that she would remember all. She declares it must have been a dream, but at last with great hesitation repeats Dr. Bernheim's words, his actions, his sticking her with a pin, and so on. The latent impression can thus be revived, showing that it was physiologically recorded. It is not remembered, but by a new suggestion or great effort can be revived.

A similar experience often happens in the normal state. We are absorbed in work while conversation goes on about us. We hear nothing at the time, and we have no idea of what has been said. Later, a chance association, or what not, shows that we had really been taking in what was said, though absorbed by our own work. The proof of this power of revivification is important as an aid to the explanation of hypnotic states, and is equally valuable in the medico-legal complications that might arise from them.

FATIGUE OF SIGHT. — Experiments have recently been made showing in what order a fatigued eye recovers the power of perceiving different colors. The important factor is what color has been used to induce fatigue. If the eye has been fatigued by long exposure to red, the sensitiveness for green is the first to re-appear, then for blue, then yellow, and finally red. After a "blue-fatigue,"

the order is yellow, red, green, blue; after a "green-fatigue," the order of recovery is red, blue, yellow, green; after "yellow-fatigue," it is red, blue, green, yellow. The eye recovers last the perception of the color by which the fatigue has been induced, and first recovers the sensitiveness for the complementary color. The fatigue is in the retina, for it is an independent phenomenon in the two eyes. The point of finest vision, the fovea, requires a longer time to recover from color-fatigue than the less sensitive lateral portions of the retina. The physiological process is considered to be related to the visual purple of the rods and cones.

SENSE OF TASTE. — In the case of a patient whose entire tongue, including the large circumvallate taste-papillæ at the root of the tongue, had been removed, it was found that some power of taste remained. The sensations of sweet, bitter, and sour could be obtained by applying appropriate substances to the back of the pharynx or the stump of the tongue, though if applied to the tongue the taste was apparent only during swallowing. The taste of salt was not perceived. Though these results are not fully in harmony with previous experiments, they are helpful in localizing the tasting-powers of various portions of the mouth cavity.

ACROPHOBIA. — Among the many curious psychological experiences that are now attracting attention, the one to which the term "acrophobia" has been applied has many points of interest. It refers to an exaggerated condition of the fear when in high places. Dr. Verga has recently described the phenomena in his own case. Though by nature not at all timid, all his courage leaves him when above ground. He has palpitations in mounting a step-ladder; finds it extremely unpleasant to ride on top of a coach, or even to look out of a first-story window. His idiosyncrasy forbids him to use an elevator, and the mere thought of those who have cast themselves down from high places causes tingling all over his person. The thought of the earth spinning through space is enough to cause discomfort. He finds this fear growing upon him as sight and hearing become less acute, and what walking in high places was formerly possible for him is getting more and more difficult. A greater or less degree of this fear is undoubtedly quite common. A very intense form of it seems perfectly consistent with normal mental functions.

COLOR-BLINDNESS. — Examinations in English schools tend to bear out the opinion that color-blindness is often declared to be present, when really no organic defect, but only a poor training in the naming and distinction of colors, is apparent. Some pupils, who at first seemed unable to tell colors, could be taught to do so in a few hours. One boy always called black white, and white black, and regarded colors in general as of little importance. Of one hundred boys examined, not one could be declared color-blind; of two hundred boys who were set to arranging and matching shades, none found any difficulty after a few hours' practice; and all could distinguish ordinary colors.

NOTES AND NEWS.

PROFESSOR SHALER of Harvard has just published in the "Memoirs of the Museum of Comparative Zoology," by permission of the director of the Geological Survey, a report on the Cambrian district of Bristol County, Mass., including a discussion of twenty-three species of fossils in the lower Cambrian section, from localities previously unknown to science. The total section of Cambrian beds exposed has a thickness of about seven thousand feet, and below that section there is a pre-Cambrian series of unknown depth, but probably approaching ten thousand feet. The report includes a geological map of the district, and two plates of fossils.

— Frederick Schwatka, the noted Arctic traveller, who made the longest sledge-journey on record in search of Sir John Franklin's remains, is about to head an expedition through the hitherto unknown northern mountains of Mexico.

— Surgeon-Gen. Hamilton has gone to Chicago on official business, and will be absent from Washington for a month. He reports progress in his efforts to reduce Florida cities to a safe sanitary condition.

SCIENCE:

A WEEKLY NEWSPAPER OF ALL THE ARTS AND SCIENCES.

PUBLISHED BY

N. D. C. HODGES,

47 LAFAYETTE PLACE, NEW YORK.

[Entered at New York Post-Office as second-class mail-matter.]

SUBSCRIPTIONS.—United States and Canada.....	\$3.50 a year.
Great Britain and Europe.....	4.50 a year.
<i>Science Club-rates for the United States and Canada (in one remittance):</i>	
1 subscription 1 year.....	\$ 3.50
2 " 1 year.....	6.00
3 " 1 year.....	8.00
4 " 1 year.....	10.00

Communications will be welcomed from any quarter. Rejected manuscripts will be returned to the authors only when the requisite amount of postage accompanies the manuscript. Whatever is intended for insertion must be authenticated by the name and address of the writer; not necessarily for publication, but as a guaranty of good faith. We do not hold ourselves responsible for any view or opinions expressed in the communications of our correspondents.

VOL. XIII.

NEW YORK, JAN. 18, 1889.

No. 311.

CONTENTS:

THE WHITE ELEVATED ELECTRIC RAILROAD.....	33	MENTAL SCIENCE.	
ELECTRICAL NEWS.		Negative Suggestions.....	41
Light without Heat.....	34	Fatigue of Sight.....	41
New Secondary Batteries.....	35	Sense of Taste.....	41
Is a Vacuum an Electric Conductor?.....	35	Acrophobia.....	41
Electric Light in the Patent Office.....	35	Color-Blindness.....	41
THE OBSERVATORY HILL RAILWAY OF ALLEGHENY CITY, PENN.....	35	NOTES AND NEWS.....	41
SCIENTIFIC NEWS IN WASHINGTON.		EDITORIAL.....	42
The Archæology of the District of Columbia.....	38	The Death of Mr. Z. L. White.—Political Influence in New York Schools.	
Our Future Empire.....	38	AFRICA, ITS PAST AND FUTURE.	
Science and Psychos.....	38	Gardiner G. Hubbard.....	42
CENSUS OF THE DEFECTIVE CLASSES.	38	BOOK-REVIEWS.	
		Hypnotism or Mesmerism.....	50
		AMONG THE PUBLISHERS.....	50

SCIENCE RECORDS WITH REGRET the death by consumption of Mr. Z. L. White, who for some months has served as its Washington correspondent. It occurred in Nassau, N.P., to which balmy island Mr. White fled a month ago for his health. He was one of the best-equipped and best-known of Washington correspondents. For years he had charge of the *Tribune* bureau, and later represented the interests of the *Philadelphia Press*. He became much talked about in connection with the publishing of the treaty of Washington before it was officially given out, and was imprisoned by the Senate for refusing to betray the gentleman from whom he obtained it. In addition to the meed of praise which the press of the country will accord to Mr. White for unusual enterprise and intelligent industry, we gladly bear witness that he was a careful observer and an accurate compiler of scientific news. E. J. Gibson, the Philadelphia representative of the *Press* in Washington, said to our correspondent, "I first became acquainted with Mr. White while he was the Washington correspondent of the *Tribune*, eleven years ago. I was then employed in the editorial rooms of the paper in New York, and during the time Mr. White remained connected with it I had opportunity to become well acquainted with him, and

always found him a most agreeable associate and a man of the highest honor. He worked his way up in the *Tribune* office in a comparatively short time, promotion coming as a result of his energy and ability, and in that respect he was often referred to in the office as an example for new-comers. His acquaintance with public men gave him a great advantage in the collection of news, and at a convention he was able to get at the bottom facts in a very short time. His newspaper work was so well known, both on the *Tribune* and the *Philadelphia Press*, that there is no need to speak of it. He was a studious, unassuming man, and a gentleman in every sense of the word. Few newspaper men had the confidence of so many public men, and he was never accused of betraying a confidence. His kindly manner made him friends wherever he went, and he was always cheerful and hopeful."

WE HAVE FREQUENTLY had occasion to comment upon the condition of the New York City schools during the past year. This condition, and the influences that are at work in them, have far more than local interest. At the organization of the Board of Education for 1889, which took place last week, the controlling influence of the political machines was again made manifest, and those who had hoped for some improvement in this respect were bitterly disappointed. Two members of the board, who had expressed themselves publicly as in favor of a change, deserted their colleagues at the critical moment. The most contemptible and discreditable political methods had been used to bring this result about, and it again places in the president's chair the man whose previous course we so thoroughly disapproved of in our comments at the time of the contest of last spring. It is a serious matter, also, that the great city newspapers either keep their readers in ignorance of what is going on, or else endeavor to have them sympathize with it. It is the simple fact that the New York City schools to-day are in the hands of the political spoilsmen, and they use them to provide places for themselves and their friends, and to perpetuate abuses from which they derive personal benefit. From the president of the Board of Education and the superintendent of schools, down to the very janitors, there is a mass of intrigue and chicanery which is a disgrace not only to the city of New York, but to the country.

AFRICA, ITS PAST AND FUTURE.¹

AFRICA, the oldest of the continents, containing the earliest remains of man, and the birthplace of European civilization, is the last to be explored. Long before the temples of India or the palaces of Nineveh were built, before the hanging garden of Babylon was planted, the pyramids of Cheops and Cephren had been constructed, the temples of Palmyra and Thebes filled with worshippers.

Greece owes its civilization to Egypt: its beautiful orders of architecture came from the land of the Nile. The civilization of Egypt had grown old, and was in its decay, when Rome was born. Think what a vast abyss of time separates us from the days of Romulus and Remus! And yet the pyramids of Egypt were then older by a thousand years than all the centuries that have passed since then.

For ages upon ages, Africa has refused to reveal its secrets to civilized man, and, though explorers have penetrated it from every side, it remains to-day the dark continent. This isolation of Africa is due to its position and formation. It is a vast, ill-formed triangle, with few good harbors, without navigable rivers for ocean-vessels, lying mainly in the torrid zone. A fringe of low scorched land, reeking with malaria, extends in unbroken monotony all along the coast, threatening death to the adventurous explorer. We wonder that we know so much, rather than so little, of Africa. Our ignorance of Africa is not in consequence of its situation under the equa-

¹ Annual address of Hon. Gardiner G. Hubbard, president of the National Geographic Society, at its meeting, December, 1888.

tor, for South America in the torrid zone has long been known. There the explorer easily penetrates its recesses on its great rivers, — the Orinoco, Amazon, and La Plata, — for they are navigable from the ocean far into the interior. The Amazon, 3,000 miles from its mouth, is only 210 feet above the ocean-level, and, with its branches, is navigable for 10,000 miles. Africa also has three great rivers, — one on each side of this peninsula. On the north, the Nile, the river of the past, empties into the Mediterranean Sea, but its navigation is soon interrupted by five cataracts; so that the camel, the ship of the desert, bears the wares of Europe from the foot of the first cataract far up the river, 800 miles, to Berber, whence they are again shipped by boat 2,000 miles to Gondokoro, close to the lakes Albert and Victoria Nyanza, 4,000 feet above the sea-level, 4,200 miles by water from the Mediterranean.

On the west, the Kongo, the river of the future, empties into the Atlantic Ocean under the equatorial sun; but its navigation is also impeded by successive falls extending from its mouth to Stanley Pool. Then there is almost uninterrupted navigation on the river and its tributaries for 10,000 miles. Far inland the head waters of its north-eastern branches interlace with the waters of the Nile. Another branch rises in Lake Tanganyika in eastern Africa, while the main river finds its source higher up in the mountains, north of Lake Nyassa, 5,000 feet above the sea-level. On the east the Zambezi, the great river of southern Africa, empties into the Indian Ocean opposite Madagascar. The navigation of its main branch, the Shire, is interrupted not far from the ocean. The Zambezi itself is navigable to the rapids near Tete, 260 miles from its mouth; while one or two hundred miles higher up are the mighty falls of Victoria, only exceeded in volume of water by the Niagara, and nearly equal in height.

In whatever direction Europeans attempted to penetrate Africa, they were met by insurmountable obstacles. Communication by water was prevented by falls near the mouths of great rivers. The greater part of the coast was most unhealthy, and, where not unhealthy, a desert was behind it; but these obstacles, which formerly prevented exploration, now stimulate the traveller to explore the dark continent. The modern explorations of Africa commenced one hundred years ago, when Mungo Park crossed the Desert of Sahara, and lost his life in descending the Niger. From that time to the present, travellers in ever-increasing numbers, entering Africa from every side, have undertaken its exploration. Some who have entered from the Atlantic or Pacific coasts have been lost in its wilds, and nothing heard of them for one, two, or three years, when they have emerged on the opposite coast; others have passed from the coast, and have never been heard from, stricken down by disease, or killed by the natives. Zanzibar has been a favorite starting-point for the lake region of Central Africa. Stanley started from Zanzibar on his search for Livingstone with two white men, but returned alone. Cameron set out by the same path with two companions, but, upon reaching the lake region, he was alone. Keith Johnson, two or three years ago, started with two Europeans; within a couple of months he was gone. Probably every second man, stricken down by fever or accident, has left his bones to bleach along the road. Drummond, a recent explorer of Africa, chose a route by the Zambezi and Shire Rivers as healthier and more desirable. Let us hear his experience. Early in his journey, at the missionary station of Livingstonia, on Lake Nyanza, he entered a missionary home: it was spotlessly clean; English furniture in the room, books lying about, dishes in the cupboards; but no missionary. He went to the next house: it was the school; the benches and books were there, but neither scholars nor teacher. Next, to the blacksmith shop: there were the tools and anvil, but no blacksmith. And so on to the next and the next, all in perfect order, but all empty. A little way off, among the mimosa groves, under a huge granite mountain, were graves: there were the missionaries.

The Niger is the only river in all Africa navigable any considerable distance above its mouth, by small steamers adapted to its navigation; but the Niger does not give access to the interior, as it rises within 100 miles of the ocean, and, after making a great bend around the mountains of the Guinea coast, empties into the ocean only about five degrees south of its source, after a course of 2,500 miles. Its main branch, the Benue (or "Mother of Waters"), is navigable 500 or 600 miles above its junction with the Niger. The

country through which it flows is thickly peopled and well cultivated; but the natives are fierce and warlike, and have until recently prevented any exploration of the Benue.

The Mountains of Africa.

As mountain-ranges determine the course of rivers, influence the rainfall, and temper the climate, we must understand the mountain system of Africa before we can understand the continent as a whole.

From the Red Sea to the Cape of Good Hope, successive ranges of mountains follow the coast, sometimes near, at others two or three hundred miles inland; the land, in the latter case, rapidly ascending from the coast. The only breaks in this long chain are where the Zambezi and Limpopo force their way to the Indian Ocean. High peaks are found all along these ranges.

In Abyssinia, on the Red Sea, there is a range of snow mountains 14,700 feet in height. A few hundred miles to the south-east, and near Lake Victoria Nyanza, is Kilima Ndjaro, 18,700 feet high, — the highest mountain in Africa, — and the mountains of Massal-Land, a continuation of the Abyssinian Mountains. Another range, apparently an offshoot of the long range from the Red Sea, forms a wall 100 miles long, and 10,000 feet high, on the east of Lake Nyassa, separating the waters of the lake from the Indian Ocean. This range continues to the Zambezi. South of this river the mountains rise 8,000 to 10,000 feet in height. In Cape Colony are several ranges of mountains. The highest peak is Compas Berg, 8,500 feet. West of these ranges, in the equatorial region, is an elevated plateau in which is the lake region, then other ranges, and a gradual descent towards the Atlantic. There are no continuous ranges of mountains on the western coast; but at Kamerun there is a cluster of mountains reaching an elevation of 13,100 feet; and south of Morocco some of the peaks of the Atlas Mountains reach an elevation of 12,000 to 13,000 feet, but they have little if any influence on the rainfall or temperature of the country. It will be seen from this statement that in eastern Africa are high mountain-ranges and an elevated plateau; that the land in equatorial Africa gradually descends toward the west and north-west until within one or two hundred miles of the Atlantic Ocean, when the descent is rapid to the low and unhealthy coast-lands. North of Cape Colony, in the territory claimed by Portugal, the general elevation of the interior is 3,000 feet or over, sloping towards the valley of the Kongo near the equator, then north of the Kongo rising to an elevation of about 2,000 feet, and descending to 1,200 feet at Lake Chad.

Careful computations have been made to ascertain the average elevation of the continent. The mean of the most careful estimates is a little over 2,000 feet. The interior is therefore elevated above the miasmatic influences of the coast, but exactly what effect this elevation has upon the temperature can only be ascertained after careful investigation and a series of observations. North of Guinea and Senegambia the coast is less unhealthy; but, as the Desert of Sahara extends to the ocean, the country is of little value, and is therefore left to the native tribes, unclaimed by Europeans.

In the International Scientific Series it is stated that there are in Africa about ten active volcanoes, — four on the west coast, and six on the east, — but I have not found any corroboration of this report, and think it very doubtful if there are any volcanoes now in operation. The Kilima Ndjaro and Kamerun were formerly active volcanoes, for the craters still exist. In the south the diamond-fields are of volcanic ash formation.

The lake region of Africa stretches from the waters of the Nile three degrees southward, to the waters of the Zambezi, fifteen degrees south, — a lake region unequalled, in extent and volume of water, except by our lakes. Here is the Victoria Nyanza, the queen of inland seas, 4,000 feet above the sea-level; and a long series of lakes, great and small, at equal elevation. The more striking are Bangweolo to the south-west, the grave of Livingstone, and Nyassa on the south-east. In their depths the Nile, the Kongo River, and the Shire (the main branch of the Zambezi) have their source.

The great belt of equatorial Africa, situated between the 15th parallel of north latitude and the 15th parallel of south latitude, has continuous rains, is everywhere well watered, and has a rich and fertile soil. Some portions are thickly populated, and

it is capable of sustaining a dense population. North and south of this belt there are two other belts of nearly equal width. In each of these belts there are wet and dry seasons, with abundant rain for the crops. The heaviest rainfall in the north belt is in June, while in the south belt it is in December. The rainfall gradually grows less toward the north, and also toward the south, until it ceases in the Desert of Sahara on the north, and the Desert of Kalahari on the south. On the edge of each of these deserts are Lake Chad on the north, and Lake Ngami on the south. North of the Desert of Sahara, and south of the Desert of Kalahari, there is an abundant rainfall, a healthy climate, and fertile soil. Morocco, Algiers, Tripoli, and Egypt, on the Mediterranean, are in the north region; and Zulu-Land, the Orange Free State, and Cape Colony, in the corresponding region of the south.

That portion of Africa north of the equator is three or four times greater than that south, and the Sahara Desert and Lake Chad are several times greater than the Kalahari Desert and Lake Ngami. The Sahara Desert, the waterless ocean three times as large as the Mediterranean, extends from the Atlantic Ocean to the Red Sea, broken only by the narrow valley of the Nile. It is interspersed with oases, and with the valleys of many dry streams, with some mountains 8,000 feet. It has the hottest climate in the world. Travellers tell us, that, in upper Egypt and Nubia, eggs may be baked in the hot sands; that the soil is like fire, and the wind like a flame; that in other parts of the desert the sand on the rocks is sometimes heated to 200° in the day-time, while in the following night the thermometer falls below freezing-point. In crossing the desert the traveller will hardly need a guide, for the road is too clearly marked by the bones and skeletons that point the way.

Lake Chad receives the drainage of a considerable area of country. In the dry season it has no outlet, and is then about the size of Lake Erie. In the wet season it is said to be five times as large. Its level rises by twenty or thirty feet until it overflows into the Desert of Sahara, forming a stream which runs northward for several hundred miles, and is finally lost in a great depressed plain. In the southern part of Africa the level of Lake Ngami rises and falls in a similar manner.

Through the great equatorial belt runs the Kongo, one of the wonderful rivers of the world. The more we know of this river and its tributaries, the more we are impressed by its greatness and importance. Its principal source is in the mountain-range which separates Lake Nyassa from Lake Tanganyika, between 300 and 400 miles west of the Indian Ocean; thence it runs southerly through Lake Bangweolo. On leaving this lake, it takes a north-west course, running from 12° south latitude to 2° north latitude, thence running south-westerly to the ocean, nearly 3,000 miles. The river Sankuru, its principal tributary, empties into the Kongo some distance above Stanley Pool on the south. The mouths of the Sankuru were discovered by Stanley, who was struck by the size and beauty of the river, and by the lakes which connect it by a second outlet with the Kongo; but he little realized the magnitude of the river. Even before the journey of Stanley, Portuguese explorers had crossed several large streams far to the south of the Kongo, — the Kuango, the Kassai, and the Lomami, — and explored them for several hundred miles, but were unable to follow them to their mouths. In 1885 and 1886, Wissmann and the Belgian explorers sailed up the Sankuru to the streams discovered by the Portuguese. The next largest branch is the Obangi, now called the Obangi-Welle, which flows into the Kongo, on the westerly side of the continent, a little south of the equator. An expedition organized by the Kongo Free State steamed up this river in the winter of 1887 and 1888, and solved the problem, so long discussed, of the outlet of the Welle. The expedition left the Kongo in the steamer "En Avant," Oct. 26, 1887. It passed several rapids, and steamed to 21° 55' east longitude, when it was stopped by the "En Avant" running on a rock, and the opposition of hostile natives. Here it was only 66 miles from the westernmost point on the Welle reached by Junker, and in the same latitude, each stream running in the same direction, leaving no room to doubt that the two waters unite.

The Little Kibali, which rises a little to the west of Wadelai in the mountains of Sudan, is the initial branch of this river, which bears successively the name of "Kibali," "Welle," and "Doru,"

and empties into the Kongo under the name of "Obangi," after a course of 1,500 miles.

Appropriation of Africa by Europe.

The English, French, Germans, and Belgians have within a few years planted colonies in Africa. They believe it is more for their interest to colonize Africa than to permit their surplus population to emigrate to America. In Africa the colonies must depend upon the home country, and open new fields for manufactures and commerce. These countries realize the necessity of creating new markets, if they are to continue to advance. They know that in equatorial Africa there are more than 100,000,000 people wanting every thing, even clothes.

The whole coast of Africa on the Mediterranean, Sea, the Atlantic and Indian Oceans from the Red Sea to the Isthmus of Suez, is claimed by European nations, with the exception of two or three small inhospitable and barren strips of coast. England occupies Egypt, and will hold it for an indefinite period. France has its colonies in Tripoli, Algiers, and Morocco, and on the Atlantic coast its factories in Senegambia. It seeks a route from Algiers across the desert to Lake Chad, and from Senegambia up the Senegal by steamer, thence across the country by rail to the head of navigation on the Niger, and down that river to Timbuctu.

England occupies Sierra Leone, the Gold and Slave Coasts, the delta and the valley of the Niger, and its branch the Benue. It has factories on these rivers, and small steamers plying on them, and seeks Timbuctu by the river Niger. It controls almost the entire region where the palm-oil is produced.

Timbuctu, long before Africa was known to Europe, was the centre of a large trade in European and Asiatic goods. Caravans for many hundred years have crossed the Desert of Sahara from Timbuctu north to the Mediterranean, and east to Gondokoro, carrying out slaves, gold, and ivory, and bringing back European and Asiatic goods. Sandwiched between the English possessions, Liberia struggles for existence, its inhabitants fast degenerating into barbarism.

Joining the English possessions on the Gold Coast, two degrees north of the equator, are the German possessions of Kamerun, with its high mountains and invigorating breezes; but the land at the foot is no more favorable to the European than the Guinea coast. One or two hundred miles in the interior of this part of the continent, the land rapidly rises to the tableland of equatorial Africa, rich and fertile, resembling the valley of the Kongo, possibly habitable by Europeans.

Next the French occupy the Ogowe, its branches, and the coast, and claim the country inland to the possessions of the Kongo Free State. Under M. Brazza, they have thoroughly explored the country to the river Kongo, and have established factories at Franceville and other places.

The Kongo Free State comes next. It holds on the coast only the mouth of the river, its main possessions lying in the interior. Belgium is the only country that has planted colonies inland. Like all the interior of equatorial Africa, the valley of the Kongo is well watered, has continuous rains. The land is rich and fertile, but it is practically inaccessible, and before any colonies can flourish, or any extensive commerce can be carried on, must be connected by railroad with the ocean. The Compagnie du Congo has just completed a survey for a railroad on the south side of the Kongo, from Matadi, opposite Vivi, to Stanley Pool. It did not encounter any unusual difficulties, and has submitted the plans and projects to the King of Belgium for his approval.

South of the Kongo Free State are the Portuguese possessions of Angola, Benguela, and Mossamedes. Portugal, the first country to circumnavigate Africa, and the first to colonize it, has for several centuries had factories, and carried on a large trade with Africa, exchanging clothes and blankets for slaves, gold, and ivory. The Portuguese claimed the valley of the Kongo; but their claim has been reduced, and is now bounded for a considerable distance on the north by a line running due east, and west on the 6th parallel of south latitude. They have good harbors at Loango Po, Benguela, and Mossamedes, on the Atlantic coast, and the best harbor of Africa at Delagoa Bay on the Indian Ocean. The territory they claim will, I believe, prove to be the most valuable in Africa. It is well

watered by numerous tributaries of the Kongo, and by the Zambezi and its branches. It is higher than the Kongo valley, and is therefore more healthy. Several Portuguese, English, and German travellers have crossed and recrossed this part of the continent, and the Portuguese have some small settlements on the coast and in the interior. The Portuguese of the present generation have not the

The only harbor on the coast is now held by the English; and, from the character of the country, we are not surprised that the Germans have abandoned it, for we are told that "the coast is sandy and waterless, deficient in good harbors, and devoid of permanent rivers, washed by never-ceasing surf, bristling with reefs, and overhung by a perpetual haze."



1, British. 2, French. 3, German. 4, Spanish. 5, Italian. 6, Portuguese. 7, Kongo Free State. 8, Liberia. 9, South African and Orange Free States.

APPROPRIATION OF AFRICA BY EUROPEANS.

enterprise and trading spirit of their forefathers, and are doing very little for the settlement of the country.

South of the Portuguese possessions, England claims from the Portuguese possessions on the Atlantic to their possessions on the Pacific, including Namaqua-Land, Cape Colony, the Transvaal, and Zulu-Land. Namaqua and Damara Land, formerly claimed by the Germans, are now put down on some of the maps as claimed by them; but, excepting a small colony at Angra Pequena, it is now, I believe, all claimed by the English.

North of Zulu-Land, the Portuguese claim the coast of Zanzibar. Over Zanzibar, Germany has lately assumed the protectorate, under a treaty with the Sultan of the country, claiming the land from the ocean to the great lakes; then England again, a little to the north of Zanzibar, the rival of Germany in its claims. The English have factories north-west of Zanzibar, and a regular route up the Zambezi and Shire Rivers, with a single portage to Lake Nyassa, and a road to Lake Tanganyika. They have steamers on each of the lakes, and several missionary and trading stations. The latest news from

this part of Africa says the route to the lakes has been closed, and the missionaries and merchants murdered.

North of the English possessions, the coast to the Red Sea is barren and inhospitable, little rain and no harbors, and so worthless that it has not been claimed by any European nation. North of this region is Abyssinia on the Indian Ocean and Red Sea,—a mountainous country with deep valleys, rich and fertile, but most unhealthy. Three or four thousand feet above the level of the sea, is a healthier country, inhabited by a race of rugged mountaineers, whom it has been impossible to dispossess of their lands. On the Red Sea, Italy has a small colony at Massaua, and England a camp at Suakin. The only parts of the coast not claimed by Europeans are inhospitable, without population or cultivation of any kind.

The Belgians have spent many millions in the exploration of the Kongo and its tributaries. They have several small steamers making trips from Leopoldville up the river to Stanley Falls, and up its branches, supplying the main stations on the river and its branches. The Kongo Free State, unlike all other African colonies, is free to all. Merchants of any nation can establish factories, carry on trade, and enjoy the same privileges and equal facilities with the Belgians. The valley of the Kongo, and the plateau of the great lakes, have a similar climate and soil; but the Kongo is easier of access, provisions are cheaper, more readily obtained, the natives less warlike. The Kongo Free State will therefore be more rapidly settled than any other part of the equatorial regions excepting Cape Colony.

The trade with these countries is carried on by European companies under royal charter, with quasi-sovereign powers for ruling the country and governing the natives, as well as for trading with them. England, Germany, and Portugal subsidize steamship companies which make regular trips along the western coast, stopping at the different stations.

From this statement it will be seen that England occupies the healthiest portion of Africa (Cape Colony), the most fertile valleys (the Nile and the Niger), the richest gold-fields (Gold Coast and Transvaal); that Portugal comes next, claiming the most desirable portion of equatorial Africa north of Cape Colony and south of the Kongo, but that it is unable to colonize this country, which will inevitably fall under the control of England; that the French claim Algiers and Senegambia, and are contending with England for the trade of Timbuctu and the upper valley of the Niger; that Germany, after vain attempts to penetrate the interior from Kamerun or Angra Pequena, has planted her flag at Zanzibar, and has determined to contest with England for the lake region and the great plateaus of Central Africa; while Italy, imitating the other states, tries in vain to obtain a footing on the Red Sea, worthless if obtained.

Population.

The population of Africa is roughly estimated at 200,000,000,—about 18 to a square mile, as against 88 in Europe. It is supposed that Africa was originally inhabited by the Hottentots, or Bushmen, who are now found only in south-western Africa, and by the pygmies or dwarfs scattered about Central Africa, who, some say, belong to the same group. This group is noted for its dwarfed stature, generally under five feet; but whether their size is natural, or due to privation and scanty food, is not certainly known. The Hottentot language is distinct from any other known form of speech. They seem to have been driven from Central Africa by the Bantu. The Bantu occupy the greater part of Africa south of the equator. They probably formerly inhabited north-eastern Africa, but were driven from their homes by the Hamites. The Bantu resemble the Negro in their general character, color, and physique, but their language shows essential differences. There are countless tribes of Bantu, each tribe having its own language, yet there was originally a primeval Bantu mother-tongue, from which all the dialects of this immense region are undoubtedly derived. The idioms of this family are generally known as the altilateral class of languages. North of the Bantu are the Negroes proper, occupying the greater part of Africa between 5° and 15° north latitude. The negro tribes are multitudinous, and, though alike in their main physical features, are diverse in their speech.

North of the Negro are the Nuba Fulah group, apparently indigenous to Africa, but without any thing in common with the other indigenous groups. Their name, "Pullo," or "Fulah," means "yel-

low," and their color serves to distinguish them from the Negro. The Hottentot, Bantu, Negro, and Fulah, though distinct, have each of them the agglutinative forms of speech. The Hamites are found along the valley of the Nile and in Abyssinia. The Semitic tribes occupy the larger part of the Sudan, bounded on the east by the Nile, and on the north by the Mediterranean and northern Atlantic coast.

About one-half of the population are Negroes proper, one-fourth Bantu, one-fourth Semites and Hamites, a few Nuba Fulahs and Hottentots. There are almost innumerable tribes, speaking different languages or different dialects. Over six hundred tribes and languages have been classified by Shilo, yet each is generally unintelligible to the other. Practically speaking, there are but two great divisions among the inhabitants of Africa,—the Negroes and Bantu, occupying equatorial and southern Africa; and the Hamites and Semites of northern Africa. But there is no clear-cut line even between the Mohammedan and Negro. For many hundred years the Negroes have been taken as slaves, and carried into the north of Africa, and have furnished the harems with wives, and the families with servants. The servants are often adopted into the families, so that the Negro blood now largely predominates even among the Semites and Hamites.

A broader and more practical distinction than that of language or blood is made by the religion of the African. The Mohammedan religion was probably brought from Arabia by the Semites. They conquered the country along the coasts, and exterminated or pushed to the south the former inhabitants. Then, more slowly but steadily, Mohammedanism forced its way south by the sword or by proselyting. Within the last fifty years it has re-assumed its proselyting character, and is now more rapidly extending than at any previous time.

Its missionaries are of a race nearly allied to the Negro. They live among them, adopting their customs, and often intermarrying with them. They teach of one God, whom all must worship and obey, and of a future life whose rewards the Negro can comprehend. They forbid the sacrifice of human victims to appease the wrath of an offended deity. They forbid drunkenness. They give freedom to the slave who becomes a Moslem, and thus elevate and civilize those among whom they dwell. The Christian missionary is of a race too far above him. He is a white man, his lord and master. He teaches of things his mind cannot reach, of a future of which he can form no conception; he brings a faith too spiritual; he labors with earnestness and devotion, even to the laying-down of his life. Yet the fact remains that Christianity has produced but little impression in civilizing and elevating the people, while the influence of Mohammedanism is spread on every side.

In passing from the equator south, the tribes become more degraded. Sir Henry Maine enunciated the theory of the evolution of civilization from the lowest state of the savage. In Africa he could have found all stages of civilization; in the lowest scale, man and his mate, living entirely on the fruits of the earth, in a nude condition, his only house pieces of bark hung from the trees to protect him from the prevailing wind. The vulture guides him to where, the previous night, the lion had fallen on his prey, leaving to him the great marrow-bones of the elephant or the giraffe; his only arms a stick, belonging to no tribe, with no connection with his fellow-man, his hand against every man, the family relation scarcely recognized. His mental condition is shown by his inability to count more than two: all above that is many. It is the land of the gorilla, and there seems to be little difference between the man and the ape, and, like wild beasts, they are hunted, and shot by the Boers. In ascending the scale, the family and tribal relation appears,—a house built of cane and grass or the bark of the tree; a few flocks; skill in setting traps for game; the weapon a round stone, bored through, and a pointed stick fastened in the hole. Then come tribes of a low kind of civilization, that cultivate a little ground, having a despotic king, who has wives without limit, numbering in some cases, it is said, 3,000; wives and slaves slaughtered at his death, to keep him company and serve him in another life. With them, cannibalism is common, and of these it is said that "when the sun goes down, all Africa dances." Then come tribes of a higher civilization, where the power of the chief is limited; where iron, copper, and gold are manufactured, and trade

is carried on with foreigners; where fire-arms have been substituted for the bow and spear. Next comes the Mohammedan, and last of all, on the shores of the Mediterranean, the civilization of the French and English.

It is a curious fact that many tribes that had made considerable advance in manufacturing iron and copper, have for some time ceased manufacturing; and that some have retrograded, and have lost some of the arts they formerly possessed. This decline apparently took place after the Mohammedans had conquered North Africa, and sent their traders among the Negro tribes, who sold the few articles the Negro needed cheaper than they could manufacture them, and therefore gave up their own manufactures. Such was the effect of free trade on interior Africa. The Mohammedans also manufacture less than formerly, depending more and more upon European manufactures. The enterprise of the white races defies native competition, and stifles attempts at native manufactures; there is therefore in all Africa a great falling-off in the progress of outward culture, and the last traces of home industries are rapidly disappearing.

Slave-Trade.

One of the departments of this society is the geography of life. At the head of all life stands man: it is therefore within our province to investigate those questions which more intimately concern and influence his welfare.

Slavery and the slave-trade have, within the last two hundred years, affected African life more than all other influences combined; and this trade, with all its sinister effects, instead of diminishing, is ever increasing. It has had a marked effect not only on the personal and tribal characters of the inhabitants, but on their social organization, and on the whole industrial and economic life of the country. It has not only utterly destroyed many tribes, but it has made the condition of all the other tribes one of restless anarchy and insecurity. It has been the great curse of Africa, and for its existence the Christian nations of Europe have been and are largely responsible. The temper and disposition of the Negro make him a most useful slave. He can endure continuous hard labor, live on little, has a cheerful disposition, and rarely rises against his master.

There are two kinds of slavery, — home and foreign. The first has always prevailed in Africa. Prisoners taken in war are either sacrificed, eaten, or made slaves. Slavery is also a punishment for certain offences, while in some tribes men frequently sell themselves, or by some act become slaves. These slaves are of the same race and civilization as their masters. They are usually well treated, regarded as members of the family, to whom a son or daughter may be given in marriage, the master often preferring to keep his daughter in the family to marrying her to a stranger. This slavery is a national institution of native growth. It is said one half of the inhabitants are slaves to the other half. The horrors of the slave-trade are unknown in this kind of slavery.

In the other case the slave is torn from his home, carried to people, countries, and climates with which he is unfamiliar, and to scenes and civilization which are uncongenial, where he is the slave of a master of a different color and of another and higher civilization, where the master and slave have nothing in common. The Spaniards made slaves of the Indians of America, but they were incapable of work, unfitted for slavery, and rapidly faded away. In pity for the Indians, the Africans were brought to supply their places. Their ability to labor was proved, and they were soon in great demand.

The slave-trade, as a regular commercial business, is said to have originated from a patent of Charles V. to one of his favorites, granting the exclusive right to transport 4,000 Negroes annually to the Spanish possessions in America. The patent was sold to some Genoese merchants for 25,000 ducats. The business was profitable; and respectable companies were formed in other countries to carry on a trade, protected and sometimes subsidized by the government.

In 1619 a Dutch company sent a cargo of slaves to Jamestown, Va., and thus slavery commenced in the United States. The Parliament of Great Britain incorporated the African Company of England; and by the Treaty of Utrecht, A.D. 1715, a contract for

supplying the Spanish colonies with slaves was transferred to Great Britain, and sold to the English African Company, which held the monopoly for over thirty years.

The Portuguese Company of Guinea, in 1701, contracted to furnish 10,000 "tonnes" of Negroes a year for the Spanish Main. The higher the civilization, the more cruel the master; and in no country does the slave seem to have fared worse than in Jamaica, for while the slave-trade lasted the slaves were worked to death. In one hundred years prior to 1807, when the slave-trade was abolished, 270,000 female, and 330,000 male slaves, or 600,000 in all, were imported into Jamaica. If the slave population had increased as the Negroes have increased in Jamaica since the Emancipation, the number in 1807 should have exceeded 1,000,000: it was in reality only 320,000. Although the slave-trade was abolished, it was still carried on clandestinely. When slavery was abolished in 1837, the Negro population was 300,000: in 1881 it was 600,000. Since the abolition of slavery, work has almost entirely ceased; and Jamaica, from being one of the wealthiest of islands, has become one of the poorest. But the Negro population, instead of decreasing as in slavery times, has rapidly increased.

It is impossible to ascertain the number of slaves imported into America. The estimates vary from 4,000,000 to 5,000,000. The larger number is probably an underestimate. These figures do not represent the number shipped from Africa, for 12½ per cent were lost on the passage, one-third more in the "process of seasoning;" so that, out of 100 shipped from Africa, not more than 50 lived to be effective laborers.

Livingstone, who studied the question of slavery most carefully, estimated, that, for every slave exported, not less than five were slain or perished, and that in some cases only one in ten lived to reach America. If the lowest estimate is taken, then not less than 20,000,000 Negroes were taken prisoners or slain to furnish slaves to America. No wonder that many parts of Africa were depopulated.

Though the slave-trade with America has been suppressed, thousands are annually stolen and sold as slaves in Persia, Arabia, Turkey, and central and northern Africa. Wherever Mohammedanism is the religion, there slavery exists; and to supply the demand the slave-trade is carried on more extensively and more cruelly to-day than at any previous time. The great harvest-field for slaves is in Central Africa, between 10° south and 10° north latitude. From this region caravans of slaves are sent to ports on the Indian Ocean and the Red Sea, and thence shipped to Indo-China, the Persian Gulf, Arabia, Turkey in Asia, and even to Mesopotamia, wherever Mussulmans are found. The English at Suakin are a constant hindrance to this traffic; and therefore Osman Digma has so often within the past five years attacked Suakin, and endeavored to take it from the English to hold it as a port from which to ship slaves to Arabia. Other caravans are driven across the desert to Egypt, Morocco, and the Barbary States. Portuguese slave-traders are found in Central Africa, and, though contrary to law, deal in slaves, and own and work them in large numbers. Cameron says that Alrez, a Portuguese trader, owned 500 slaves, and that to obtain them, ten villages, having each from 100 to 200 souls, were destroyed; and of those not taken, some perished in the flames, others of want, or were killed by wild beasts. Cameron says, "I do not hesitate to affirm that the worst Arabs are angels of mercy in comparison to the Portuguese and their agents. If I had not seen it, I could not believe that there could exist men so brutal and cruel, and with such gayety of heart." Livingstone says, "I can consign most disagreeable recollections to oblivion, but the slavery scenes come back unbidden, and make me start up at night horrified by their vividness."

If the chief or pacha of a tribe is called upon for tribute by his superior, if he wishes to build a new palace, to furnish his harem, or fill an empty treasury, he sends his soldiers, armed with guns and ammunition, against a Negro tribe armed with bows and spears, and captures slaves enough to supply his wants.

The territory from which slaves are captured is continually extending; for, as soon as the European traveller has opened a new route into the interior, he is followed by the Arab trader, who settles down, cultivates the ground, buys ivory (each pair of tusks worth about \$500 at Zanzibar or Cairo); who invites others to come,

and when they have become acquainted with the country, and gathered large quantities of ivory, and porters are wanted to carry the tusks to the coast, a quarrel is instigated with the Negroes, war declared, captives taken,—men for porters, women for the harem,—the villages are burned, and the caravan of slaves and ivory takes its route to the coast, where all are sold. We are told on good authority that during the past twenty years more slaves have been sent out than formerly were exported in a century. Wissmann tells us what he has seen:—

“In January, 1882, we started from our camp,—200 souls in all,—following the road, sixty feet wide, to a region inhabited by the Basonge, on the Sankuru and Lomami Rivers. The huts were about twenty feet square, divided into two compartments, the furniture consisting of caned wooden stools; floor, ceiling, and walls covered with grass mats. Between the huts were gardens, where tobacco, tomatoes, pine-apples, and bananas were grown. The fields in the rear down to the river were cultivated with sweet-potatoes, ground-nuts, sugar-cane, manioc, and millet. Goats and sheep and fowls in abundance, homestead follows homestead in never-ending succession. From half-past six in the morning, we passed without a break through the street of the town until eleven. When we left it, it then still extended far away to the south-east. The finest specimens in my collection, such as open-work battle-axes inlaid with copper, spears, and neat utensils, I found in this village.

“Four years had gone by, when I once more found myself near this same village. With joy we beheld the broad savannas, where we expected to recruit our strength and provisions. We encamped near the town, and in the morning approached its palm-groves. The paths were no longer clean, no laughter was heard, no sign of welcome greeted us. The silence of death breathes from the palm-trees, tall grass covers every thing, and a few charred poles the only evidence that man once dwelt there. Bleached skulls by the roadside, and the skeletons of human hands attached to the poles, tell the story. Many women had been carried off. All who resisted were killed. The whole tribe had ceased to exist. The slave-dealer was Sayol, lieutenant of Tippto-Tip.”

Sir Samuel Baker was largely instrumental in the suppression of the slave-trade, and, while the rule of the English and French in Egypt was maintained, slavery was greatly diminished; but, since the defeat and death of Gen. Gordon, the slave-trade has rapidly increased, and is now carried on more actively than at any other time. The only obstacles to this traffic are the presence of Emin Pacha at Wadelai, the English and American missionaries, and English trading-stations on Lakes Victoria Nyanza and Tanganyika.

The slave-traders unite in efforts to destroy Emin Pacha, and to expel the missionaries and all European traders, except the Portuguese, and for this purpose excite the hostility of the Negro against the foreigner. In this they are aided by the Mahdi. The work of the Mahdi is largely a missionary enterprise. The derishes who accompany his army are religious fanatics, and desire the overthrow of the Christians and Emin Pacha as earnestly as the slave-trader. Religious fanaticism is therefore united with the greed of the slave-trader to drive out the Christians from the lake region.

Aroused by these reports, and influenced by these views, Cardinal Lavigerie, last summer, started a new crusade in Belgium and Germany against slavery and the slave-trade. The cardinal has organized societies, and is raising a large fund to equip two armed steamships for Lake Tanganyika and Lake Nyassa, the headquarters of the slave-trade, and offers, if necessary, to head the band himself. The Pope has engaged in the work, and has sent Catholic missionaries to Central Africa. The slave-trade is carried on with arms and ammunition furnished by all the European traders. Without these arms, the slave-trade could not be successfully carried on, for the Negroes could defend themselves against slave-traders armed like themselves. While the demand for slaves continues, the slave-trade will exist, and will not cease until the factories of European nations are planted in the interior of Africa.

Mineral Wealth of Africa.

We are told in Phillips's "Ore Deposits" that the precious

metals do not appear to be very generally distributed in Africa. I believe that more thorough research will show that this view is incorrect, and that there are large deposits of iron, copper, gold, and other metals in many parts of the continent. Gold is found on the Gold Coast, in the Transvaal, in the Sudan, and in Central Africa, but only worked in surface diggings, excepting in the Transvaal; but near all these washings, gold nuggets of large size, and the quartz rock, have been discovered. In Transvaal the mines were worked a long time ago, probably by the Portuguese, then abandoned and forgotten. Recently they have been rediscovered, and worked by the English. In the Kaap gold-field in the Transvaal, three years ago, the lion and zebra, elephant and tiger, roamed undisturbed in the mountain solitudes, where there is now a population of 8,000, with 80 gold-mining companies, having a capital of \$18,500,000, one-third of which is paid up. Barberstown, the chief mining-town, has two exchanges, a theatre, two music-halls, canteens innumerable, several churches and hotels, four banks, and a hospital. A railroad was opened in December, 1887, from the Indian Ocean towards these mines, 52 miles, and is being rapidly constructed 100 miles farther to Barberstown.

There is reason to believe that gold deposits equal to those of Mexico or California will yet be found in several parts of Africa. Copper is known to exist in the Orange Free State, in parts of Central and South Africa, and in the district of Katong, southwest of Lake Tanganyika, which Dr. Livingstone was about to explore in his last journey. Rich copper ores are also found in the Cape of Good Hope, Abyssinia, and equatorial Africa. Large and excellent deposits of iron ore have been found in the Transvaal and in Algiers, and a railroad 20 miles long has been built to carry it from the Algerian mines to the sea. Very many tribes in equatorial and Central Africa work both iron and copper ores into different shapes and uses, showing that the ore-beds must be widely distributed.

One of the few large diamond-fields of the world is found in Griqua and Cape Colony, at the plateau of Kimberly, 3,000 feet above the sea. The dry diggings have been very productive; this tract, when first discovered, being almost literally sown with diamonds.

Coal has been found in Zulu-Land, on Lake Nyassa, and in Abyssinia. The latter coal-field is believed to be secondary. Iron, lead, and zinc, and other minerals, have been found in the Orange Free State. Salt-beds, salt-fishes, salt-lakes, and salt-mines are found in different parts of Africa.

Railroads.

The peculiar formation of Africa, its long inland navigation, interrupted by the falls near the mouths of its large rivers from connection with the ocean, renders it necessary to connect the ocean with the navigable parts of the rivers by railroads.

The Belgians will soon construct a railroad on the southerly side of the Kongo, to the inland navigable waters of the Kongo at Leopoldville, following the preliminary surveys lately completed; the French may also construct a road from the coast to Stanley Pool; and by one or the other of these routes the interior of Africa will be opened.

South of the Kongo, the Portuguese are constructing a railroad from Benguela into the interior. In Cape Colony railroads have been constructed in different directions, connecting the greater part of the British possessions with the Cape of Good Hope. They are also constructing a railroad from Delagoa Bay to the mines in Transvaal.

Sudan and the upper waters of the Nile can only be opened to a large commerce by a railroad from Suakin to Berber, about 280 miles. Surveys were made for this road, and some work was done upon it, just before Gen. Gordon's death. The navigation of the Nile above Berber is uninterrupted for many hundred miles. Below Berber the falls interrupt the navigation. The route from Gondokoro down the Nile is by boat to Berber, camel to Assuan, boat to Siut, and railroad to Cairo and Alexandria, making a route so circuitous that it prevents the opening of the Sudan to any extensive commerce.

In Algiers there are 1,200 miles of railroad, and more are being constructed. The French are also constructing a railroad from

the upper part of the Senegal River to the head waters of the Niger. The English have organized a company to construct a road from the Gold Coast to the mines in the interior.

It will thus be seen that the railroad has already opened a way into Africa that is sure to be carried on more extensively.

Stanley Expedition.

There are two methods of exploring Africa. One is where an individual, like a Livingstone or a Schweinfurth, or Dr. Junker, departs on his journey alone. He joins some tribe as far in the interior, on the line of exploration, as possible; lives with the tribe, adopting its habits and manner of life, learning its language, making whatever explorations he can; and, when the region occupied by such tribe has been fully explored, leaves it for the next farther on. This plan requires time and never-failing patience; but in this way large portions of Africa have been explored. The other way, adopted by Cameron, Stanley, Wissmann, and the Portuguese explorers, has been to collect a party of natives, and at their head march across the continent.

"An immense outfit is required to penetrate this shopless land, and the traveller can only make up his caravan from the bazaar at Zanzibar. The ivory and slave traders have made caravanning a profession, and every thing the explorer wants is to be found in these bazaars, from a tin of sardines to a repeating-rifle. Here these black villains the porters—the necessity and despair of travellers, the scum of slave-gangs, and the fugitives from justice from every tribe—congregate for hire. And if there is any thing in which African travellers are for once agreed, it is, that for laziness, ugliness, stupidity, and wickedness, these men are not to be matched on any continent in the world." Upon such men as these Stanley was obliged to depend.

Though travelling in this way is more rapid than the other, it is very expensive, and has many difficulties not encountered by the solitary traveller. The explorer always goes on foot, following as far as possible the beaten paths. A late traveller says: "The roads over which the land-trade of equatorial Africa now passes from the coast to the interior are mere footpaths, never over a foot in breadth, beaten as hard as adamant, and rutted beneath the level of the forest-bed by centuries of native traffic. As a rule, these foot-paths are marvellously direct. Like the roads of the old Roman, they move straight on through every thing,—ridge and mountain and valley,—never shying at obstacles, nor anywhere turning aside to breathe. No country in the world is better supplied with paths. Every village is connected with some other village, every tribe with the next tribe, and it is possible for a traveller to cross Africa without being once out of a beaten track."

But if the tribes using these roads are destroyed, the roads are discontinued, and soon become obstructed by the rapid growth of the underbrush; or, if the route lies through unknown regions outside the great caravan-tracks, the paths are very different from those described by Mr. Drummond, for the way often lies through swamps and morass, or thick woods, or over high mountain-passes, or is lost in a wilderness of waters.

The great difficulty in these expeditions is to obtain food. As supplies cannot be carried, they must be procured from the natives. Very few tribes can furnish food for a force of six hundred men (the number with Stanley); and when they have the food, they demand exorbitant prices. Often the natives not only refuse food to the famished travellers, but oppose them with such arms as they have; and then it is necessary, in self-defence, to fire upon them.

The greatest difficulty the explorer meets comes either directly or indirectly from the opposition of the slave-trader. Formerly the slave-trader was not found in equatorial Africa; but, since the explorer has opened the way, the slave-trader has penetrated far into the interior, and he is continually throwing obstacles in the way of the entry of Europeans into Africa. When it was decided that Stanley should relieve Emin Pacha, he was left to choose his route. He met Schweinfurth, Junker, and other African travellers, in Cairo. They advised him to go by his former route directly from Zanzibar to the Victoria Nyanza. The dangers and difficulties of this route, and the warlike character of the natives, he well knew. The route by the Kongo to Wadelai had never been travelled, and he thought the difficulties could not be greater than by the old route; and, beside,

he proceeded much farther into the interior by steamer on the Kongo, which left a much shorter distance through the wilderness than by the Zanzibar route. On arriving at Zanzibar, he made an arrangement with Tippoo-Tip, the great Arab trader and slave-dealer, for a large number of porters. They sailed from Zanzibar to the Kongo, where Stanley arrived in February, 1887. He then sailed up the Kongo, and arrived in June at the junction of the Aruvimi with the Kongo, a short distance below Stanley Falls. Stanley believed that the Aruvimi and the Welle were the same stream, and that by following up this river he would be on the direct route to Wadelai. Subsequent investigations have shown that he was mistaken. About the 1st of July he left the Kongo, expecting to reach Emin Pacha in October, 1887. No definite information has been received from him from that time to the present. He left Tippoo-Tip in command at Stanley Falls, expecting that a relief expedition would follow. There were great delays in organizing this expedition, from the difficulty of obtaining men, and it was thought that Tippoo-Tip was unfaithful. The men were finally procured, and the expedition left Aruvimi in June, 1888, under command of Major Barttelot. A day or two after they started, Major Barttelot was murdered by one of his private servants. The expedition returned to the Kongo, and was re-organized under Lieut. Jamieson. He was taken ill, and died just as he was ready to start, and no one has been found to take his place; and that relief expedition was abandoned. Reports say that Stanley found the route more difficult than he anticipated; heavy rainfalls, rivers, swamps, and marshes obstructed the way; and that the season was sickly, and a large part of his followers died long before he could have reached Tanganyika.

The reports of his capture, and of his safe return to the Aruvimi River, are known to all. These may or may not be true. Although we have not heard from Stanley for a year and a half, yet it by no means follows that he is dead; for Livingstone, Stanley, and other explorers have been lost for a longer time, and have afterward found their way back to the coast. No man has greater knowledge of the country through which his route lay, or of the character of the natives, or the best manner of dealing with them. Emin Pacha was encamped quietly for nearly two years at Wadelai; and Stanley, in like manner, may have been compelled to remain at some inland point and raise his own provisions.

The Future of Africa.

It is impossible to prophesy the future of any country, much less that of Africa, where the physical features have left so marked an impression upon its inhabitants, and where the animal life is so different from that of the other continents. It is rather by differentiating Africa from other countries that we obtain any data from which to form an opinion of its future.

Africa, as we have seen, is surrounded by a fringe of European settlements. What effect will these settlements have upon Africa? 1st, Will the European population penetrate the interior, and colonize Africa? 2d, Will it subjugate or expel the Africans, or will they fade away like the Indians of our country? 3d, If colonization by Europeans fail, will the African remain the sole inhabitant of the country as barbarian or civilized?

Egypt is now controlled by the English, but its climate is too unhealthy, and its surrounding too unfavorable, for Englishmen; and we may safely assume that their occupation will be temporary, or, if permanent, not as colonists. They will remain, as in India, foreigners and rulers, until the subjugated people rise in their power and expel them, and return to their old life. The English rule, though possibly beneficial to Egypt, is hated by the natives, who demand Egypt for the Egyptians.

Leaving Egypt, we pass an uninhabitable coast, until we come to the French colonies of Algiers. It is nearly sixty years since the French took possession of Algiers. There has been a large emigration from France; but the climate, while excellent as a winter climate for invalids and others, is unfavorable for a permanent habitation, especially for infants. The births in one year have never equalled the deaths. When Algeria was first conquered by the French, it was a wilderness, but is now a garden. The cultivation of the grape has been most successful, and extensive iron-mines have been opened. The French are gradually pushing their way from Algiers across the desert to Timbuctu, and also from Sen-

gambia to Timbuctu. The expense of maintaining the colony has greatly exceeded any revenue derived from it. Though many doubt the political wisdom of retaining it, yet the French have too much pride to acknowledge that the enterprise has been in any way a failure; and they will undoubtedly hold it, and perhaps found an empire. Senegambia and the coast of Guinea, claimed by the French and English, are low and moist, filled with swamps and lagoons, and will prevent any European colonization.

South of the Kongo, the Portuguese claim a wide section of country running across Africa. They have occupied this country over two hundred years. They have done little towards colonizing, and only hold a few trading-posts on the coast and in the interior, dealing principally in slaves, ivory, and gold; and it may well be doubted whether, without holding slaves, they have the stamina or ability to colonize this country, or to produce any permanent impression upon it.

The south portion of Africa, from the 18th parallel on the Atlantic to the 26th parallel on the Indian Ocean, is generally fertile; and the climate is favorable to Europeans, and is capable of sustaining a large population. The growth of Cape Colony has been very slow, but a more rapid growth is anticipated. We believe it will be permanently occupied by the English, who will dispossess the aborigines, and form a great and permanent English state. The coast of Zanzibar, occupied by the Germans and English, is rich and fertile, the climate unhealthy; but when the mountain-ranges are crossed, and the elevated plateaus and lake regions are reached, the interior resembles the Kongo region. Massaua and Suakin, on the Red Sea, are unhealthy and worthless, unless connected by railroad with the upper Nile.

There remains equatorial Africa, including the French settlements on the Ogowe, the region about Lake Chad, the Kongo and its tributaries, and the lake region. The more we learn of equatorial Africa, the greater its natural advantages appear to be. The rivers open up the country in a favorable manner for trade and settlement. Its elevation from 2,000 to 3,000 feet will, I believe, render it healthy, though this elevation is only equal to from ten degrees to fourteen degrees of north latitude. Here all the fruits of the torrid zone, the fruits and most of the grains of the temperate zone, cotton, India-rubber, and sugar-cane, are found.

The country has been unhealthy, a great many Europeans have died, and few have been able to remain more than two or three years without returning to Europe to recuperate. These facts seem to show that the climate is not healthy for Europeans. But, by reason of the exposure incidental to all new settlements, the mortality has been much greater than it will be when the country is settled and the unhealthy stations have been exchanged for healthier localities. Every new country has its peculiar dangers, which must be discovered and understood, then overcome. I believe that these obstacles will be overcome, and that Europeans will occupy all this region, and that it will become a European colony.

If European colonization is successful, European civilization will come into contact with African barbarism. Where such a contest is carried on in a country where the climate is equally favorable to the two races, it can only result in the subjugation or destruction of the inferior race. If the climate is unfavorable to the white population, then, unless the inferior is subjected to the superior, the white population will fail in colonizing the country, and the Negro will either slowly emerge from barbarism, or return to his original degraded condition.

The Negroes have never developed any high degree of civilization; and when they have lived in contact with civilization, and made considerable progress when that contact ceased, they have deteriorated into Barbarism. But, on the other hand, they have never faded away and disappeared, like the Indian of America and the natives of the Southern Archipelago.

Nature has spread a bountiful and never-ending harvest before the Negro, and given to him a climate where neither labor of body or mind, nor clothing, nor a house, is essential to his comfort. All nature invites to an idle life; and it is only through compulsion, and contact with a life from without, that his condition can be improved.

In Africa there is going on a contest between civilization and

barbarism, Christianity and Mohammedanism, freedom and slavery, such as the world has never seen. Who can fail to be interested in the results of this conflict? We know that Africa is capable of the very highest civilization; that it was the birthplace of all civilization. To it we are indebted for the origin of all our arts and sciences, and it possesses to-day the most wonderful works of man. I believe that Africa, whose morning was so bright, and whose night has been so dark, will yet live to see the light of another and higher civilization.

BOOK-REVIEWS.

Hypnotism or Mesmerism. By CHARLES B. CORY. Boston, Mudge. 12°.

COMPARATIVELY little has been done in this country in the study of hypnotism, now occupying so prominent a place in the literatures of France, Germany, and other countries. It is the object of Mr. Cory, who is chairman of the committee on hypnotism, of the American Society for Psychical Research, to inform the American public with reference to those phenomena. Most of the papers here gathered together have been published separately, and the collection forms a very readable introduction into some aspects of the subject. A general paper on hypnotism, partly historical and partly expository, is followed by the most valuable of the papers, in which the factor played by the consent of the subject in the act of hypnotization is ingeniously analyzed. He shows, in one case, that the most intense efforts to will a patient to sleep, when the latter is unaware of the attempt, prove unavailing; while entire passivity is sufficient to cause sleep, when the subject has been led to believe that an attempt to hypnotize her is being made. Mr. Cory sums up his conclusions thus: (1) hypnotism is related to an abnormal constitution of the nervous system; (2) only a small percentage of persons are hypnotizable; (3) the condition is entirely due to suggestion, no one being hypnotizable without being informed, or led to suspect, that he is to be the object of experiment; (4) the condition may be self-induced; (5) in certain cases the hypnotic is insensitive. Mr. Cory's experiments on negative hallucinations are extremely ingenious. He shows, that, when an object is removed by suggestion from the field of vision, the subject takes note of some peculiarity by which to recognize that she is to ignore it. What the eye sees, the mind refuses to recognize. If a number of precisely similar objects are presented, the subject has no longer a clew as to which impression is to be ignored, and the suggestion fails. Mr. Cory has also a talk upon the therapeutic value of hypnotism.

AMONG THE PUBLISHERS.

THE new "Century Dictionary," which has been in course of preparation by The Century Company during the past seven years, is approaching completion, and it is expected that the issue of the work will begin during the coming spring. It will be published by subscription, and in parts, or "sections;" the whole, consisting of about 6,500 pages, to be finally bound into six quarto volumes. Although the printers have been engaged upon the type-setting for more than two years, the publishers have waited until the labor of making the plates is so well advanced that the work can be regularly issued at intervals of about a month, and completed within two years. Probably no work of greater magnitude or importance has been put forth by an American house. The editor-in-chief, Professor William Dwight Whitney of Yale University, who is perhaps the highest authority in philology in both America and England, has been assisted by nearly fifty experts, college professors, and others, each a recognized authority in his own specialty; the design of the dictionary being to make it complete and authoritative in every branch of literature, science, and the arts. It is intended that the botanist shall find in the "Century Dictionary" full definitions of terms in his special line of study; that the civil engineer and the architect can turn to it for the definitions (usually with plans and pictures) of the terms in their own specialties; and so with every other pursuit or profession, — law, music, medicine, chemistry, anatomy, archæology, zoölogy, mineralogy, theology, etc. Each expert is reading the proofs of the entire work; indeed, the

proofs are read by more than sixty people. For seven years not fewer than a hundred persons, and sometimes more, have been working upon this dictionary. Trained readers have been searching the fields of English literature for words, and uses of words, and quotations. Over two thousand authors will be quoted; and it is understood that American books, and even the current literature of the magazines, have been liberally drawn upon. The growth of the English language at the present day is astonishing. It is said that the new "Encyclopædia Britannica" alone furnished ten thousand new words to be defined in the "Century Dictionary." These were generally technical words, which had been coined by the writers of articles in the "Encyclopædia;" but nevertheless they are now born into the language, and are liable to be met with in any one's reading. The new dictionary will contain definitions of probably two hundred thousand words, and these without including any useless compounds. Thousands of quotations, from the vast store which the readers have gathered, will help to illustrate the uses of these words. The work is encyclopedic; that is, encyclopedic in the sense that it gives, in addition to definitions and the etymological history of words, a very great amount of detailed information which has hitherto been found only in the encyclopædias, and often not even in them. There will be about six thousand cuts in the text, the subjects of which have usually been chosen by the experts in charge of the special departments. They have been drawn, whenever possible, from the object itself, and engraved under the supervision of the Art Department of The Century Company. The engravings are said to be of a higher class than have yet found place in any work of this character. It is understood that all rights have been obtained for the issue of this dictionary throughout the English-speaking world, and that it will be published in England simultaneously with its issue in this country.

— Messrs. Longmans, Green, & Co. are about to follow Mr. Besant's "Eulogy of Richard Jefferies" with a volume of Jefferies's uncollected papers, under the apt title of "Field and Hedgerow," in which will appear the latest essays of the Englishman who best continued the tradition of White of Selborne. Among the subjects are "Hours of Spring," "The Makers of Summer," and "Time of Year," which are treated with the sympathy and the knowledge that lead a critic to call Jefferies "the English Thoreau."

— The article on "Walter Scott at Work," by E. H. Woodruff, in the February *Scrivener's*, will contain facsimiles of many interesting pages from the proof-sheets of "Feveril of the Peak," with the pithy criticisms of Ballantyne and replies of Scott on the margin. This literary treasure was purchased in London twenty years ago by Ex-President Andrew D. White of Cornell, who furnishes an introduction to the article. Bishop Potter of New York, in an essay which will appear in the same number, on "Competition in Modern Life," says, "Let us understand, then, that competition—a strife to excel, nay, if you choose, downright rivalry—has a just and rightful place in the plan of any human life. A prize-fight is probably the most disgusting spectacle on earth, but it has in it just one moment which very nearly approaches the sublime; and that is when the combatants shake hands with each other and exchange that salutation as old as the classic arena, 'May the best man win.' It is the equitable thing that the best man should win." George H. Jessop, the playwright, will contribute the story of an Irish outrage, called "The Emergency Men," told from the landlord's point of view. C. D. Gibson, of *Life*, will illustrate it. In an article on "The Physical Development of Women," which Dr. D. A. Sargent of Harvard College will contribute, he says, "At the present time women as a class have more leisure than men for self-improvement, and we must look to them to help on the higher evolution of mind and body, not only in perfecting themselves, but in helping to perfect others. Already three-fourths of the school-teaching force in the United States is composed of women, and they will soon be in the majority as instructors in physical training. The gospel of fresh air and physical improvement is being slowly imbibed by our best families, and the stock of fine specimens of physical womanhood is slowly and steadily improving." W. C. Brownell, whose articles on "French Traits" have received a great deal of discriminating praise, will contribute the last of the group, which discusses

"The Art Instinct." The essays, with several not heretofore printed, will soon be published in book-form. Thomas Sergeant Perry will describe an interesting collection of Græco-Egyptian portraits discovered in 1887 near Fayoum. Professor Ebers believes that some of them were painted three or four centuries before the Christian era. The article is to be fully illustrated from photographs of the originals.

— Messrs. Dodd, Mead, & Co. have issued a catalogue of books, including some of exceeding rarity, such as perfect specimens from the presses of William Caxton, Wynkyn de Worde, and Richard Pynson; a unique copy of the original folio edition of Ben Jonson's works, printed on large paper, with autograph inscription; the original quarto edition of Sidney's "Arcadia;" also the original manuscript of W. H. Ireland's "Shakesperian Forgeries" (numbering 174 lots), together with other desirable rare and choice books. This firm is at all times ready to price, and desirous of purchasing, good books. They are paying special attention to rare books, especially those relating to the early history of America, and would be glad to hear from any one who has books of real value, of which the owner may for any reason wish to dispose.

— Messrs. Cupples & Hurd, Boston, announce for immediate publication "The Eggs of North American Birds," by C. J. Maynard. Such a book has long been needed by students on oölogy, for there is no work upon the subject by any American author which can be called complete. The book begins with the descriptions of the eggs of the water-birds, and the species are numbered as in the "List of the American Ornithologists' Union," the nomenclature being the same so far as it is there given; but every species and subspecies that have been described up to date are included, considerably augmenting that list. All known eggs are described, and the description of each is given so clearly as to render it readily distinguishable. In case of rarities, this is often accomplished by comparison with some well-known species, or with the figured type, of which there are eighty, contained in ten plates, carefully drawn on stone by the author, and accurately colored by hand by Mrs. Maynard. The dimensions of the largest and smallest of a large series of the eggs of each species, number of eggs deposited, nesting-time, breeding-range, and description of nests, are given. At this late day, it is perhaps needless to state that the author has pursued his usual course in preparing the text of the work, and has never used a technical term when a simple one would answer. As a consequence, the descriptions are at once available to all classes of students. The work will be complete in eight parts, each part containing a description of seventy species, more or less, and at least one or two hand-colored plates. The entire work, it is expected, will be completed by the 1st of May, 1889. Sold only by subscription.

— Edward Allen Fay's "Concordance of the Divina Commedia" (Boston, Little, Brown, & Co.) is published under the auspices of the Dante Society, of which James Russell Lowell is president, and Charles Elliott Norton is vice-president. It was reviewed at length in the *Nation* for Oct. 25, 1888. The reviewer closed by saying, "Dr. Fay has put on the titlepage of his book the motto 'In che i gravi labor gli sono agratti.' It well denotes the loving and accurate care with which he has performed his heavy task. His book—the first of its kind in centuries—is not for a day: full generations of lovers and students of Dante will place it on their shelves beside the 'Divina Commedia.'"

— Max O'Rell's book on the United States, which has been awaited with so much eagerness, will be published toward the end of this month by Messrs. Cassell & Co. It will be issued in Paris and London at about the same time. M. Calmann Levy, who publishes the book in France, has already taken advance orders for forty thousand copies; the English outlook is quite as good; and in this country there is every reason to anticipate a sale far exceeding that of England or France. Messrs. Cassell & Co. have paid M. Blouet (Max O'Rell) the largest lump sum that has ever been paid a foreign author for the right of publication in this country. The title of this book is "Jonathan and His Continent; Rambles through American Society," by Max O'Rell and Jack Allyn. The work of translating has been admirably done by Madam Blouet,

who is an English woman and a thorough French scholar. One who has had the privilege of glancing over the proof-sheets of Max O'Rell's book pronounces it the brightest thing he has done, and predicts that it will make a much greater sensation than "John Bull and His Isle," great as was the commotion caused by that clever skit. In giving his impressions of society in the United States, Max O'Rell is often severe, but always kind. He makes a number of statements, however, that are going to call forth contradictions in various quarters, and are likely to stir up some strong criticisms. Each of the great cities that he visited—Philadelphia, Boston, Chicago, etc.—is honored by a special chapter. American women are also so honored, and their beauty is highly complimented; but this will hardly atone in their eyes for the charge brought against them of being badly dressed. Altogether the book is very lively reading, and will unquestionably excite the interest of every American citizen who wants to know what a keen-eyed, intelligent, and witty Frenchman has to say of him and of his country.

—Although the privilege of reprinting in book form the series of papers on "Authors at Home," which appeared in *The Critic*, was requested by a number of publishing-houses, it was the good fortune of Cassell & Co. to secure it. These articles are not mere gossiping sketches. While they are bright and interesting, they have the advantage of authorization as to facts of biography, as each author selected the person to write of him, or gave his approval where the selection was made by the editors. Messrs. Cassell & Co. wish to call attention to the fact that they intend to issue three editions of this book,—a thing unusual in the book-trade. The first will be a regular library edition at \$1.50, while the other two will be "limited" to one hundred copies each. One of these will be an *édition de luxe*, on heavy paper with generous margin, and handsomely bound, while the other will be on large paper especially prepared for "extra illustrating."

—Lee & Shepard will publish at once "Aryas, Semites, and Jews, Jehovah and the Christ," by Lorenzo Burge, author of "Pre-Glacial Man."

—George Routledge & Sons will publish shortly translations of Daudet's "Recollections of a Man of Letters," and Guy de Maupassant's "Sur L'Eau" ("Afloat"). Both volumes will be illustrated.

—Cupples & Hurd have in preparation a new edition of "The Naturalist's Guide," by C. J. Maynard; and also a new work by the same author entitled "Eggs of the Birds of the United States," illustrated by the author, to be issued in monthly parts.

—Charles Scribner's Sons have in press Dr. James McCosh's "First and Fundamental Truths: a Treatise on Metaphysics," which is regarded as the crowning philosophic work of this venerable author's long and fruitful life. They have also in hand a volume of musical essays by Henry T. Fink, the musical critic of the New York *Evening Post*, and author of "Romantic Love and Personal Beauty;" a limited edition of 500 copies of Lester Wallack's "Memories of Fifty Years;" and the Duddleian lecture on "The Validity of Non-Episcopal Ordination," delivered at Harvard University, on Oct. 28 last, by Professor George Park Fisher.

—Macmillan & Co. have in press a new work on Darwinism, by Dr. Alfred Russell Wallace, which promises to have much scientific significance. The first volume in their new English Men of Action Series will be "Gen. Gordon," by Sir William Butler. A volume will be issued each month.

—Harper & Brothers have just ready "A Latin Dictionary for Schools," by Charlton T. Lewis, the editor of "Harper's Latin Dictionary." It is not an abridgment, but an entirely new and independent work, designed to explain every word or phrase in the Latin literature commonly read in schools; viz., the complete works of Cæsar, Terence, Cicero, Livy, Nepos, Vergil, Horace, Ovid, Juvenal, Phædrus, and Curtius, the Catiline and Jugurtha of Sallust, the Germania and Agricola of Tacitus, and a few words found in some extracts of Florus, Eutropius, and Justinus. The original meaning of every word is first given, and then the modifications which it underwent in usage. The editor has preferred illustrations drawn from the earliest authors read by the students,—Cæsar's Gallic War, Cicero's Orations against Catiline, and the first books

of Vergil's *Æneid*. The general plan of the work was not finally adopted until after consultation with thirty of the leading Latin scholars and teachers in the country.

—W. H. Morrison, Washington, D.C., has just published the fourth volume of Mr. James Schouler's "History of the United States under the Constitution." The period covered is 1831-47, and the fifth (and perhaps concluding) volume, which will break off at 1861, is now in active preparation.

—Rénan has completed the second volume of his "History of the Jews." There is one more volume to come.

—Noah Brooks has written an article on the explorer Henry M. Stanley, whose real name he claims is John Rowlands. The article will appear in the February issue of the *St. Nicholas*, and will be illustrated with a new portrait of the explorer, maps, etc.

—The February instalment of the "Lincoln History," in *The Century Magazine*, will contain chapters of peculiar interest, describing (1) the events leading up to the final removal of Gen. McClellan; (2) the financial measures undertaken by Mr. Chase and advocated by Mr. Lincoln for carrying on the war; (3) the relations between President Lincoln and Secretaries Seward and Chase, including the incident of the simultaneous resignation of the two secretaries, and the manner in which Mr. Lincoln averted a political catastrophe.

—The Yankee dialect made famous in Lowell's "Biglow Papers" is now scarcely to be heard in New England, save in odd corners like the home of "Cape Cod Folks," or in the mountain fastnesses in New Hampshire, or among the Berkshire hills. A new writer, Ella Loomis Pratt, who has done some clever sketches from the last-named region in the columns of the *Springfield Republican* and other journals, has treated that life and dialect in a full-fledged novel, "A Gentleman of Fairden," which is announced as a feature of *The Literary News*, New York, for 1889. It is said to abound in pleasant and humorous pictures of places and people in the Berkshires.

—The Open Court Publishing Company, Chicago, have just issued a little pamphlet entitled "Artificial Persons: A Philosophical View of the Law of Corporations," by Charles T. Palmer. The author of this pamphlet is one of the few persons who think that corporations do not have privileges enough. His central thesis is, that a corporation ought to have and exercise all the rights and privileges that belong to a private partnership. He is specially displeased with the rule of law established by the United States Supreme Court, that a corporation chartered by one State cannot exercise corporate privileges in another State unless chartered by that other State also. But his arguments seem to us decidedly weak and inconclusive. A corporation owes its existence to its charter; and its members, in accepting the charter, accept all the conditions and restrictions which that instrument imposes, the chief of which is that they can do nothing but what their charter gives them permission to do. Having accepted these conditions, they have no right afterwards to complain of them. Instead of being a "philosophical view," Mr. Palmer's theory strikes us as both unphilosophical and impolitic.

—The *Family Mail-Bag* is the title of a monthly periodical published at 140 Nassau Street, New York. It is intended for the amusement and instruction of the whole family, and contains an interesting collection of good reading. The January number is the second that has been issued.

—Charles Waldstein's paper on "Ruskin's Work—its Influence upon Modern Life and Thought," will appear in *Harper's Magazine* for February, with a portrait of Ruskin as the frontispiece. In the same number will be printed "A Russian Village—An Artist's Sketch," by Verestchagin.

—Miss Mary F. Seymour's new paper, the *Business Woman's Journal*, which made its first appearance week before last, is devoted to the interests of all women, especially those who work either with brains or hands. It advocates higher education and the adoption of some avocation by every woman whose time is not taken up in household duties, and generally seeks to present the woman's side of every question.

Subscription Agents Wanted.

A favorable arrangement will be made with a responsible person in every community to solicit and to receive subscriptions for the following first-class publications: THE ART INTER CHANGE; THE CHRISTIAN UNION; THE CRITIC; THE FORUM; GOOD HOUSEKEEPING; PUBLIC OPINION; and SCIENCE. This list includes a standard periodical of every class, and they appeal to every taste of educated readers. An agency for these will afford light and profitable employment for responsible persons.

READING CLUBS.—Those who belong to READING CLUBS or contemplate forming them would do well to address us.

For terms address, with references:

THE FORUM PUBLISHING CO.,
253 Fifth Ave., New York.

We cordially endorse this scheme, and will add very liberal commissions for all willing to canvass for *Swiss Cross* subscriptions. N. D. C. Hodges, 47 Lafayette Place, New York.

MAP-MAKING.

All publishers or others desiring to have maps made, either from relief plates or by lithograph, should write to us for estimates before placing their orders elsewhere. Any work entrusted to us will be carefully made under the supervision of our geographical editor, Dr. Franz Boas.

N. D. C. HODGES,

Publisher of *Science*,

47 Lafayette Place,

New York

A TEMPERANCE BINDER for *Science* is postpaid on re-



NEW HANDED. RK. JANU- - 50 cents.
rocco - 75 cents.
It is strong, durable and gilt-side-titled, and allows of the pages perfectly numbered can be taken out without disturbing the contents. The papers are not mutilated by subsequent removal from this binder. *Science* is convenient for reference.

REGY.
N. D. C. 870. 25ES,
47 1 - - - - - te Place, New York.

"The Week, one of the most valuable papers on the continent."—*Descriptive Review*.

ENLARGED AND IMPROVED.

THE WEEK:

A Canadian Journal of Politics, Literature, Science and Arts.

PUBLISHED EVERY FRIDAY.

\$3.00 per Year. \$1.00 for Four Months.

THE WEEK has entered on its SIXTH year of publication, greatly enlarged and improved in every respect, rendering it still more worthy the cordial support of every one interested in the maintenance of a first-class literary journal.

The independence in politics and criticism which has characterized THE WEEK ever since its first issue will be rigidly maintained; and unceasing efforts will be made to improve its literary character and increase its value and attractiveness as a journal for the cultured home. Many new and able writers are now, or have promised to become, contributors to its columns, and the constant aid of the Publisher will be made to make THE WEEK fully equal to the best literary journals in Britain and the United States.

As heretofore, PROF. GOLDWIN SMITH will, from time to time, contribute articles. London, Paris, Washington and Montreal letters from accomplished correspondents will appear at regular intervals. Special Ottawa Letters will appear during the sessions of Parliament.

THE WEEK in its enlarged form will be the same size as "Harper's Weekly," and the largest paper of its class on the continent.

SEND FOR FREE SAMPLE COPY.

C. BLACKETT ROBINSON, Publisher,
5 Jordan St., Toronto.



PETER COOPER'S GLUE.

Prepared in liquid form by the N.Y. Liquid Glue & Adhesive Co. The long and well-known reputation of this glue for its strong adhesive properties requires no recommendation. It is the glue your furniture is glued with, and never fails to join the hardest wood if properly applied. Always ready for use. For sale everywhere.

CONTAINS NO ACID.

JOHN HASTINGS = -A-R-HART = -JOS=TRIPP =
Pres't. Gen'l Manager. V Pres't.

ENGRAVING FOR
ILLUSTRATIVE
AND ADVERTISING
PURPOSES

67-71 PARK PLACE,
NEW YORK.

SCIENCE CLUBBING RATES.

10% DISCOUNT.

We will allow the above discount to any subscriber to *Science* or *The Swiss Cross* who will send us an order for periodicals exceeding \$10, counting each at its full price.

	Year's Subscription.	With Science.	With Swiss Cross.
American Agriculturist.....	\$ 1.50	\$ 4.30	\$ 2.50
American Analyst.....	1.00	4.25	2.25
American Architect and Building News.....	10.00	12.80	11.00
Imperial edition.....	7.00	9.80	8.00
Gelatine.....	6.00	8.80	7.00
American Garden.....	1.00	4.25	2.25
American Journal of Philology.....	3.00	4.25	4.25
American Machinist.....	2.50	5.30	4.50
American Magazine.....	3.00	5.80	4.00
American Naturalist.....	4.00	7.50	5.50
Andover Review.....	4.00	6.80	5.00
Atlantic.....	4.00	6.80	5.00
Regular.....	6.00	8.80	7.00
Babylad.....	50	3.75	2.25
Bradstreet's.....	5.00	7.00	6.00
Brain.....	3.50	6.00	4.50
Electric (weekly).....	1.00	4.25	3.00
Carpentry and Building.....	1.00	4.25	2.50
Century Magazine.....	4.00	6.80	5.00
Chautauquan, The.....	1.50	4.20	2.50
Christian Union.....	3.00	5.80	4.00
Christian Weekly, Illustrated.....	4.50	7.80	6.00
Cosmopolitan.....	2.00	4.80	3.00
Critic.....	3.00	5.80	4.00
Doctor.....	2.00	4.80	3.00
Electric Magazine.....	4.00	7.80	6.00
Edinburgh Review.....	4.00	6.80	5.00
Electrical World.....	3.00	5.80	4.00
Electrician and Electrical Engineer.....	3.00	5.80	4.00
Electrical Review.....	4.00	7.80	6.00
Engineering and Mining Journal.....	4.00	6.80	5.00
English Illustrated Magazine.....	1.75	4.55	2.75
Family Story Paper (N.Y.).....	3.00	5.80	4.00
Forest and Health.....	4.00	7.80	6.00
Forum, The.....	5.00	7.80	6.00
Godey's Lady's Book.....	2.00	4.80	3.00
Harper's Bazar.....	4.00	6.80	5.00
Harper's Magazine.....	4.00	6.80	5.00
Harper's Weekly.....	4.00	6.80	5.00
Harper's Young People.....	2.00	4.80	3.00
Health and Home.....	1.00	4.25	2.25
Home and Health.....	1.00	4.25	2.25
Illustrated London News (Amer. reprint).....	4.00	6.80	5.00
Independent, The.....	3.00	5.80	4.00
Inter Ocean, The.....	1.00	4.25	2.25
Iron Age (weekly).....	4.00	7.80	6.00
Journal of Philology (Eng.).....	2.50	5.30	3.50
Journal of Speculative Philosophy (begins with Jan. No.).....	3.00	5.80	4.00
Judeo.....	1.00	4.25	2.25
L'Art.....	15.00	14.80	13.00
Life.....	5.00	7.80	6.00
Lippincott's Magazine.....	3.00	5.80	4.00
Little's Living Age.....	3.00	5.80	4.00
Little Men and Women.....	1.00	4.25	2.25
London Quarterly.....	4.00	6.80	5.00
Macmillan's Magazine.....	3.00	5.80	4.00
Magazine of American History.....	5.00	7.80	6.00
Medical and Surgical Journal.....	5.00	7.80	6.00
Mechanical Engineer.....	2.00	4.80	3.00
Metal Worker.....	1.00	4.25	2.25
Microscope, The.....	4.00	4.25	2.25
Nature.....	6.00	8.80	7.00
New Princeton Review.....	3.00	5.80	4.00
North American Review.....	5.00	7.80	6.00
Outing.....	3.00	5.80	4.00
Overland Monthly.....	4.00	8.00	5.00
Pansy.....	1.00	4.25	2.25
Political Science Quarterly.....	3.00	5.80	4.00
Popular Science Monthly.....	5.00	7.80	6.00
Popular Science News.....	3.00	4.25	2.25
Portfolio, The.....	7.50	10.30	8.50
Practitioner.....	3.50	6.30	4.50
Public Opinion.....	3.00	5.80	4.00
Puck.....	5.00	7.80	6.00
Puck (German).....	5.00	7.80	6.00
Quarterly Review (London).....	4.00	6.80	5.00
Queries.....	1.00	4.25	2.25
Rural New-Yorker.....	4.00	6.80	5.00
St. Nicholas.....	3.00	5.80	4.00
School Journal.....	2.50	5.30	3.50
Scientific American.....	3.00	5.80	4.00
Scientific American (U.S.).....	5.00	7.80	6.00
Scientific American and Builders' edition.....	2.50	5.30	3.50
Scribner's Magazine.....	3.00	5.80	4.00
Southern Cultivator.....	1.50	4.20	2.50
Springfield Republican (weekly).....	2.00	4.25	2.25
Sunday School Times.....	2.00	4.80	3.00
Teachers' Institute.....	1.25	4.05	2.25
Texas Siftings.....	1.00	6.80	5.00
Treasure-Trove.....	1.00	4.25	2.25
Truth Seeker, The.....	3.00	5.80	4.00
Wide Awake.....	2.40	5.20	3.40
Young Folks' Journal.....	1.00	4.25	2.25

N. D. C. HODGES,
47 Lafayette Place,
New York.



BRANCH AT 728 CHESTNUT ST.
PHILADELPHIA, PA.

DR. WARNER'S
CAMEL HAIR
HEALTH UNDERWEAR
 FOR MEN WOMEN AND CHILDREN.

Superior to Silk or Wool.
 A Protection against Colds, Neuralgia and Rheumatism.
 SOLD BY LEADING MERCHANTS.
WARNER BROS., 359 Broadway, New York.

**IMPROVED OIL LIGHT
 MAGIC LANTERNS.**

Also Lime and Electric Light Apparatus, and mechanical, plain, and fine colored views.
J. B. COLT & CO., Manufacturers,
 No. 16 BEEKMAN STREET, NEW YORK.

Insurance.

DELAY IS DANGEROUS.

We call attention to the new form of Accident (indemnity) Insurance policies, which are written by the Merchant's Casualty Insurance Association, 21 Park Row, New York City. John S. Purdy, Secretary. These policies cover weekly allowances of from \$10 to \$25, according to occupation, at a cost of only \$6 a year exclusive of the cost to join, which is \$5 payable once only. The public, as a rule, carry life insurance, and the ordinary accident policies issued by companies, paying a sum in case of death, is not so desirable as one of these indemnity policies in case of accidents, which are so plentiful in this fast age with its railroad horrors, fast driving, electric wires and other countless forms of danger to which the public is constantly exposed. The fact of the Association having no unpaid claims, and its having just passed an examination by the Insurance Department of New York State, shows that the management is liberal with its policy-holders and conservative in its action. The Association also desires to secure energetic Agents in every village and town, to whom territory and favorable terms will be given.



**GET THE NEW
 ACME No. 5
 MICROSCOPE**

Complete, with high-class lenses, 1 in. and 1-1/2 in.
\$28.00.
 Send for complete catalogue B, and sample of The Microscopical Bulletin.
JAMES W. QUEEN & CO.,
 924 Chestnut St., Phila.

of Vergil' adopted scholars
 — W. fourth States and the off at
 — R. the Jew
 — Stank will illust
Constable & Co.
INDIA PAPERES
CORRIGES.
 Unrivalled for Durability & Wear.
 Very new and handsome designs will be offered this week in **SPRING STYLES.**

Broadway & 19th st.
 New York.

W. H. WALMSLEY & CO.
 SUCCESSORS TO
R. & J. BECK.

1016 Chestnut Street Phila
 Microscopes and all Accessories and Apparatus. Photographic and Photo-Micrographic Apparatus and Outfits.
 Spectacles, Eye Glasses, Opera and Marine Goggles, etc.
 Illustrated Price List mailed free to any address. Mention Science in corresponding with us.

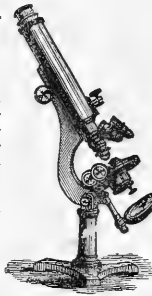

AMATEUR PHOTO-OUTFITS
BENT ANTHONY & CO.
 591 BROADWAY N.Y.
 PATENT NOVEL PARRY & DETECTIVE CAMERAS

"THE ECLIPSE."

COPYING APPARATUS.
 One thousand copies in black. No special pen, no special paper, no stencil required. The "Eclipse" reproduces the natural handwriting so exceedingly faithful that in most cases "Eclipse" circulars have been taken for ordinary written letters. Specimens and circulars on application.
FELIX F. DAUS & CO.,
 693 Broadway, New York.

THE ECLIPSE



GOOD NEWS TO LADIES.

Greatest inducements ever offered. Now's your time to get up orders for our celebrated **Teas and Coffees**, and secure a beautiful Gold Band or Moss Rose China Tea Set, Dinner Set, or Webster's Dictionary. For full particulars address **THE GREAT AMERICAN TEA CO.,** P. O. Box 229, 31 and 33 Vesey St., New York.

EVENING SILKS.

We have just received several cases of Novelty Silks for evening wear, specially intended for the approaching season. The ground colors are white and various delicate gaslight shades, and are brocaded in Silver and Gold in very unique designs.
 Orders by mail will receive careful and prompt attention.

JAMES McCREERY & CO.

BROADWAY AND ELEVENTH ST.,
 NEW YORK CITY.

J. GRUNOW,

621 Sixth Avenue, New York.
 Established 1852.

MAKER OF

Microscope Stands, Oil Immersion Objectives and Abbe Condensers for Bacterial and Histological work, of Objectives, Camera Lucida and other accessory apparatus.

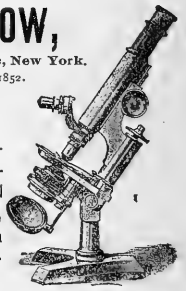

TILESTON & HOLLINGSWORTH,
 64 Federal Street, Boston.

Manufacturers of Fine Book Papers for letter press and cut printing. The attention of publishers and printers is called to our Ivory Finish (no gloss) paper. A boon to students men, reflecting no dazzling glare injurious to the eyes. Approved and used by the best educational publishers in the country.

ENGRAVINGS.

For the largest list ever published of engraved portraits on steel, suitable for illustrators and print collectors, please send for catalogue to
J. C. BUTTRE,
 32 Cortlandt St., New York.

H. WILLIAMS,

Dealer in Old Magazines, Reviews, &c. Scientific periodicals a specialty. 39 Macdougall St., N.Y.

JAHRESBERICHT DER CHEMIE [Fittica] 1877-1885 inclusive; 12 volumes in cloth, half goat. For sale at cost. Also Register zu den Berichten für 1885 bis 1876. Address Scientific Library, Smith College, Northampton, Massachusetts.

BACK NUMBERS and complete sets of leading Magazines. Rates low. AM. MAG. EXCHANGE, Schoharie, N.Y.

FOR SALE.—Journal of the Franklin Institute, Vols. 1 to 40. H. WILLIAMS, 39 Macdougall St., N.Y.

SCIENCE

SEVENTH YEAR.
VOL. XIII. No. 312.

NEW YORK, JANUARY 25, 1889.

SINGLE COPIES, TEN CENTS.
\$3.50 PER YEAR, IN ADVANCE.

LONGMANS, GREEN & CO.'S LIST.

NEW BOOKS.

FIELD AND HEDGEROW. Being the Last Essays of Richard Jefferies. Crown 8vo. \$1.75. [Just ready.]

"Jefferies' power lay in describing natural scenery and rural life with a faithfulness and a brilliancy almost unrivalled."—Nation.

THE EULOGY OF RICHARD JEFFERIES. Author of "The Gamekeeper at Home." A Memorial by Walter Besant. With Photographic Frontispiece. Crane 8vo. \$2.00. [Just published.]

"The oddest and most eloquent bit of biography we have ever read."—Philadelphia Press.

"As interesting as Mr. Besant's most interesting novels."—Daily News.

HISTORY OF THE MONGOLS. From the 9th to the 19th Century. Part III. The Mongols in Persia. By Henry H. Howorth, M.P. Royal 8vo. \$9.50.

THE SON OF A STAR. A Romance of the Second Century. By Dr. E. W. Richardson. 12mo, cloth. \$1.50.

"Dr. Richardson has written a most entertaining and at the same time instructive historical romance."—Hartford Courant.

B. C. 187. A Ramble in British Columbia. By J. A. Lees and W. J. Clutterbuck, authors of "Three in Norway." With map and 75 illustrations from sketches and photographs by the authors. Crown 8vo, ornamental cloth. \$2.25.

"The book is beautifully printed, and illustrated by excellent photo-engravings reproduced from sketches and photographs of the authors. . . . Many marvelous adventures make the book very interesting reading, and welcome to lovers of books of travel."—Science.

SCIENTIFIC BOOKS.

ELEMENTARY BIOLOGY. By R. J. Harvey Gibson, M.A., illustrated with 192 Engravings. Cloth, 12mo. \$1.75.

PHYSICAL REALISM. Being an Analytical Philosophy from the Physical Objects of Science to

the Physical Data of Sense. By Thomas Case, M.A., Fellow and Senior Tutor, C.C.C., Oxford. Cloth, 8vo. \$3.00.

FORCE AND ENERGY. A Theory of Dynamics. By Grant Allen. 8vo. \$2.25.

Longmans' Elementary Science Manuals

(NEW VOLUMES).

ELEMENTARY BUILDING CONSTRUCTION AND DRAWING. By Edward J. Burrell. Illustrated by 303 Working Drawings and Diagrams. Crown 8vo. 80 cents.

THEORETICAL MECHANICS. Including Hydrostatics and Pneumatics. By J. E. Taylor, M.A., With 175 Diagrams and Woodcuts. Crown 8vo. 80 cents.

ANIMAL PHYSIOLOGY. By William S. Fumess, Science Demonstrator London School Board. With 218 Illustrations. Crown 8vo. 80 cents.

ELEMENTARY MATHEMATICS. Specially adapted to meet the requirements of the Science and Art Department. Crown 8vo. 80 cents.

EPOCHS OF MODERN HISTORY

(NEW VOLUME.)

THE ENGLISH RESTORATION AND LOUIS XIV., 1642-1678. By Osmund Airy, one of H.M. Inspectors of Schools. Fcp. 8vo, cloth \$1.00.

EPOCHS OF MODERN HISTORY. A series of books narrating the History of England and Europe at successive epochs subsequent to the Christ's Era. Edited by Edward E. Morris, M.A., of Lincoln College, Oxford, and C. M.A. Each volume complete in itself. \$1.00.

THE NORMANS IN EUROPE. By Rev. A. H. Johnson, M.A.

THE CRUSADES. By the Rev. Sir G. W. Cox Bart, M.A.

THE BEGINNING OF THE MIDDLE AGES. By the Very Rev. R. W. Church, M.A., etc., Dean of St. Paul's.

THE EARLY PLANTAGENETS. By the Right Rev. W. Stubbs, D.D.

EDWARD THE THIRD. By the Rev. W. Warburton, M.A.

THE HOUSES OF LANCASTER AND YORK. By James Gairdner.

THE EARLY TUDORS. By the Rev. C. E. Moberly, M.A.

THE ERA OF THE PROTESTANT REVOLUTION. By F. Seebohm.

THE AGE OF ELIZABETH. By the Rev. M. Creighton, M.A., LL.D.

THE FIRST TWO STUARTS AND THE PURITAN REVOLUTION, 1602-1660. By Samuel Rawson Gardiner.

THE FALL OF THE STUARTS; AND WESTERN EUROPE FROM 1673 to 1697. By Rev. Ed. Hale, M.A.

THE AGE OF ANNE. By E. E. Morris, M.A.

THE THIRTY YEARS' WAR, 1618-1648. By Samuel R. Gardiner.

THE EARLY HANOVERIANS. By E. E. Morris, M.A.

FREDERICK THE GREAT AND THE SEVEN YEARS' WAR. By F. W. Longman.

THE WAR OF AMERICAN INDEPENDENCE, 1775-1783. By J. M. Ludlow.

THE FRENCH REVOLUTION, 1789-1795. By Mrs. S. R. Gardiner.

THE EPOCH OF REFORM, 1830-1850. By Justin McCarthy, M.P.

* * For Sale by all booksellers. Sent on receipt of price by the publishers.

LONGMANS, GREEN & CO.,

15 EAST 16th STREET,

NEW YORK.

THE SECRET DOCTRINE.

The Synthesis of Science, Religion and Philosophy.

BY H. P. BLAVATSKY,

Author of "ISIS UNVEILED," and founder of the Theosophical Society.

2 Vols. Royal Octavo. Cloth \$10.00.

AN UNPRECEDENTED LITERARY EVENT.

This book is written with the especial aim: "to show that Nature is not a 'fortuitous concourse of atoms,' and to assign to man his rightful place in the scheme of the Universe . . . to show that the occult side of nature has never been approached by the science of civilization." It is based upon stanzas from the **BOOK OF DZYAN**, an archaic MSS. unknown to the Western world, with erudite commentaries, explanations and elaborations. In the Addenda Modern Science is contrasted with Esoteric Science.

The **Darwinian theory of Evolution** is shown to be wrong, and it is asserted by the author that the Apes are not our ancestors but are degenerate descendants of prehistoric man.

The book also attempts to show that all the forms upon the earth have been produced by man who has passed through each one in his evolution.

The **Moon** is held to be the progenitor of the Earth and not a mass that was thrown off by the latter in cooling.

The author shows enormous erudition, and if readers call the book an invention they must place the writer at the head of the geniuses of the age.

CHARLES T. DILLINGHAM, 718-720 Broadway, New York.

GUARANTY INVESTMENT COMPANY

CAPITAL \$250,000.

Hon. ALBERT H. HORTON (Chief Justice, Kansas Supreme Court), Topeka, Kan., Pres't.

7% Guaranteed Farm Mortgages 7%

The Company calls the special attention of Investors to the following points :

- I. All loans guaranteed and interest payable semi-annually at the Importers' & Traders' National Bank, New York.
- II. Unusual fulness of information, not only about the security itself, but about the general development of the section where the farm is located.
- III. An examination each year of the general business of the Company and the Mortgages themselves by a COMMITTEE OF INVESTORS sent for the purpose.
- IV. Many hundred Mortgages taken and NOT A SINGLE FORECLOSURE.
- V. Exhibitions in New York at frequent intervals, of Kansas and Nebraska Farm Products. The Exhibition at the American Institute in the fall of 1888, received the *HIGHEST AWARD* of superiority.
- VI. Monthly Bulletins giving full information about all Mortgages offered for sale.

Address for Monthly Bulletin and Investors' Committee Report for 1888,

HENRY A. RILEY, General Eastern Manager, 191 Broadway, N.Y.

TILESTON & HOLLINGSWORTH,
64 Federal Street, Boston.

Manufacturers of Fine Book Papers for letter press and cut printing. The attention of publishers and printers is called to our **Ivory Finish** (no gloss) paper. A boon to studious men, reflecting no dazzling glare injurious to the eyes. Approved and used by the best educational publishers in the country.

TO EMPLOYERS.

Having purchased the fixtures, good will, &c., of the **NEW YORK EMPLOYMENT BUREAU**, at No. 681 BROADWAY, in this city, we request the patronage of the public in the future. We desire to fill a long-felt want for an employment bureau, where only the best grade of male help is dealt in, and it is our aim to send **ONLY** such help as is ordered in every instance, and our patrons can rely on us to send strictly first-class help, the references of whom we personally investigate before sending to any one. We simply request a trial, and are convinced that we will give satisfaction in every case. We have on hand help in every branch, which we can send upon receipt of telegram or letter, **AND FOR WHICH WE MAKE NO CHARGE TO AN EMPLOYER.**

NEW YORK EMPLOYMENT BUREAU,
(AS REORGANIZED).



**KIMBALL'S
STRAIGHT CUT
CIGARETTES.**

Unsurpassed in quality.
Used by people of refined taste.
Highest award at Brussels, 1888.
The finest smoking mixtures are of our manufacture.
Fifteen First Prize Medals.
WM. S. KIMBALL & CO.,
Rochester, N.Y.

KNABE

PIANOFORTES.

UNEQUALLED IN

Tone, Touch, Workmanship and Durability.

WILLIAM KNABE & CO.

NEW YORK: No. 112 Fifth Av., above 16th St.
BALTIMORE: Nos. 22 and 24 E. Baltimore St.
WASHINGTON: No. 317 Market Space, Penn. Av., near 9th St.

Old and Rare Books.

JAHRESBERICHT DER CHEMIE [Fittica] 1877-1885 inclusive; 12 volumes in cloth, half goat. For sale at cost. Also Register zu den Berichten für 1867 bis 1876. Address Scientific Library, Smith College, Northampton, Massachusetts.

A. S. CLARKE, Bookseller,

34 PARK ROW, NEW YORK CITY.

A Gleaner in the By-ways of Literature. Results of Gleaning found in Catalogues issued from time to time.

CATALOGUE NO. 27 NOW READY.

BACK NUMBERS and complete sets of leading Magazines. *Reclm. low.* AM. MAG. EXCHANGE, Scholastic, N.Y.

FOR SALE.—Journal of the Franklin Institute, Vols. 1 to 40. H. WILLIAMS, 39 Macdougal St., N.Y.

H. WILLIAMS,

Dealer in Old Magazines, Reviews, &c. Scientific periodicals a specialty. 39 Macdougal St., N.Y.

Readers of Science

Corresponding or visiting with Advertisers, will confer a great favor by mentioning the paper.

FOOD ADULTERATION

And its Detection. With photomicrographic plates and a bibliographical appendix. By J. P. Battershall. 328 pages, 8vo, cloth. Price, \$3.50. Circulars and Catalogues on application. E. & F. N. SPON, 12 Cortlandt St., New York.

WHY YOU SHOULD USE

Scott's Emulsion

OF **Cod Liver Oil** WITH
HYPOPHOSPHITES.

It is used and endorsed by Physicians because it is the best.

It is Palatable as Milk.

It is three times as efficacious as plain Cod Liver Oil.

It is far superior to all other so-called Emulsions.

It is a perfect Emulsion, does not separate or change.

It is wonderful as a flesh producer.

It is the best remedy for Consumption, Scrofula, Bronchitis, Wasting Diseases, Chronic Coughs and Colds.

Sold by all Druggists.

SCOTT & BOWNE, Chemists, N.Y.

SCIENCE

FRIDAY, JANUARY 25, 1889.

THE STORAGE OF ELECTRICITY.

ONE of the greatest drawbacks to the introduction of electricity as a servant of man has heretofore been a method of providing a suitable means of accumulating it, so as to have it at hand when and where wanted. The development of storage-batteries is doing as much to-day to advance the universal adoption of electricity as the dynamo when invented did to introduce it.

To Gaston Planté, more than to any other investigator, are we indebted for our knowledge of storage-batteries. He it was who

above, the plates of metallic lead become gradually converted into spongy lead on the negative pole, and peroxide of lead on the positive pole, and that such a cell would hold current and deliver it again with but small loss. The chief reason that a storage-battery of this character could not be made of use practically, was the fact that to form the lead plates it was necessary to pass the charging current daily back and forth by a series of reversals for many months before they became converted to their new forms.

On the discovery and perfecting of the mechanical production of electricity by means of the dynamo, the production of a suitable form of storage immediately became one of the leading questions of the day; but how this formation of Planté's plates might be has-

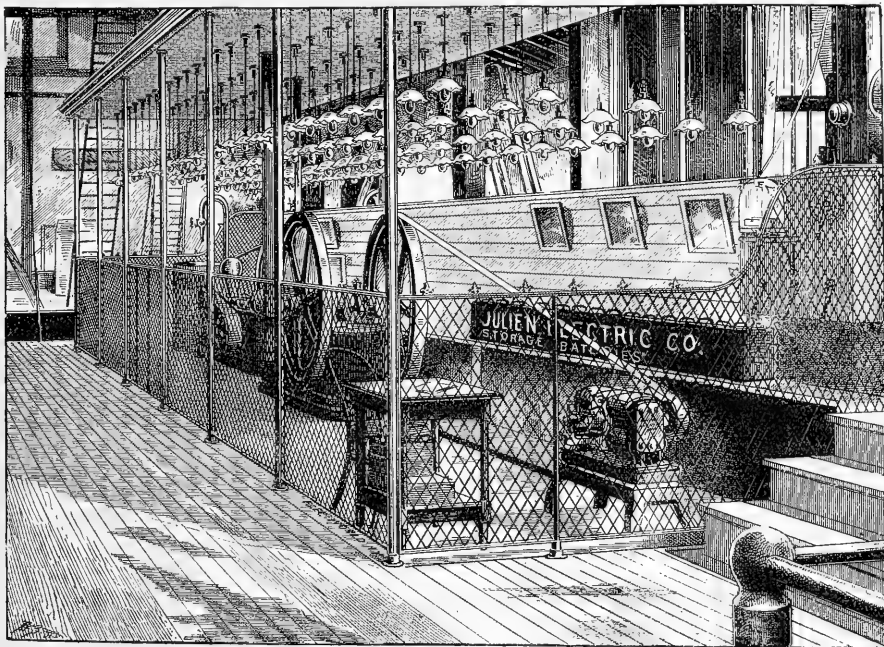

JULIEN STORAGE-BATTERY EXHIBIT AT THE AMERICAN INSTITUTE FAIR.

first took advantage of secondary currents in voltaic batteries. He examined the entire problem of the polarization of electrodes, using all kinds of metals as electrodes or plates, and many different liquids as electrolytes; but he found that the greatest efficiency was produced by electrodes of lead in diluted sulphuric acid.

The first set of Planté cells was exhibited in 1860, before the Paris Academy of Sciences. It was immediately recognized that the storage-battery had a field peculiarly its own, and that its application was only limited by the application of electricity. This was all before the introduction of the dynamo; and at that time little real commercial value was attached to the discovery, as the accumulators had to be charged by means of primary batteries, and it was then well known that electricity, when produced by chemical means, was far too expensive for any purpose outside of the laboratory.

Mr. Planté's discovery consisted of the fact, that, if a current of electricity be passed back and forth through a pile composed as

tened, so as to reduce the cost of manufacture within practical limits, was what was first to be solved. The first step forward was the artificial application of the oxides found on Planté's plates to sheets of lead which were bound on by strips of felt. After a short time, however, under the action of the sulphuric acid, these strips of felt became eaten, and the surface of the plates fell away.

It remained for Mr. Edmond Julien, a Belgian engineer, to make a battery of such a form as to be electrically and mechanically suited to the requirements. His battery consists of perforated plates or grids, into which are pressed the active materials or oxides, which, after a short charge, become almost one homogeneous mass, being what Planté in a crude way produced by the continuous action of a series of reversals of a current. This, however important, did not turn out to be his most valuable invention. When put to practical use, it was found that after a short time the positive plates showed signs of corrosion, which limited their life to about one year. He therefore entered upon the work of construct-

ing a battery free from its defects, and, after a period of six years of continuous experimenting, he produced the Julien battery in its present form (represented in the accompanying cut), founded upon the principle of an inoxidizable support plate, which is materially opposed to that employed by his predecessors. All support plates made before Mr. Julien's discovery were founded on the principle of the oxidization of the positive plates or their conversion into peroxide, so that they soon fell to pieces.

The difference between a lead plate and one composed of this inoxidizable alloy—lead, antimony, and mercury—is perfectly evident: one is practically useless, while the other can be successfully used for years. The importance of this point is made plain by a recent decision of the commissioner of patents.

The following is an extract from the report of Benton J. Hall, commissioner, Dec. 8, 1888, in the case of an interference between John S. Sellon, assignor to the Electrical Accumulator Company, and Edmond Julien:—

"The addition of mercury as a battery constituent is of great value in the formation of support plates of secondary batteries, on account of its tendency to unite with the other metal or metals of the plate, forming a more active union or contact between the plate which contains an admixture of mercury, and thus diminishing the resistance of the electrode, and therefore the resistance of the whole battery, thereby increasing the current, which is a result of the greatest importance in the use and application of secondary batteries.

"This property (that of diminishing the resistance of the electrodes) is so valuable, that, in the manufacture of plates for contact batteries, the addition of mercury to alloys of lead and antimony gives marked advantages over batteries formed of lead and antimony alone, and renders them preferred for secondary-battery purposes. This is the characteristic value of the Julien battery, or the triple alloy battery of Julien, which is so much preferred in modern use on account of its durability and efficiency.

"The action of mercury in the three-element battery—that of Julien—should at once remove it from comparison with two-metal batteries of any kind as yet known, and which appears to be due to the admixture of mercury in the alloy, which renders it unlike the other batteries with which it is classified wrongly in this interference, and with which it should not have been placed in interference; for the presence of mercury in the plate gives it a distinct and separate place, and forms a different alloy."

These plates, in addition to being inoxidizable, and thus having practically an unlimited life, are of great rigidity and mechanical durability, which enables them to be made very much lighter, and also prevents any tendency of bending, or, as it is called, "buckling," under the severe strain of heavy rates of charge and discharge.

To illustrate the difference in weight between a battery whose plates are made of pure lead and of Mr. Julien's compound, I quote from pamphlets issued by companies engaged in the manufacture of these batteries:—

	Weight of Cell in Pounds.	Capacity in Ampère Hours.	Capacity per Pound.
Gibson (lead).....	120	200	1.6
Faure (lead).....	121	300	2.5
Julien (alloy).....	32	150	4.7

The value of Mr. Julien's inventions was immediately recognized by capitalists in America, which resulted in the organization of the Julien Electric Company, to exploit his systems of traction and lighting by means of these batteries. To that company is due the great progress which has been made within the last two years in the storage-battery industry. American ingenuity and proclivity for labor-saving machinery has grappled with and overcome almost all the difficulties in the manufacture of these batteries, which, up to a short time ago, had been considered insurmountable.

The plates were at first cast, pasted, and pressed entirely by hand, and, in fact, these crude methods are still in use in Europe

and by all other makers in this country; but the Julien Company have a machine capable of producing in one day one thousand completely finished plates. It is almost automatic in its action, and requires but one attendant. All the plates are uniform, and the action of the battery is therefore free from the irregularities inseparable from hand-made batteries.

A word as to the application of storage-batteries. They have been extensively and successfully used for the following purposes: electric lighting of buildings of every description; lighting of railway-trains, street-cars, and omnibuses; the traction of all vehicles, more especially street-cars; the propulsion of yachts, launches, and pleasure-boats; the lighting of steam-vessels, etc.; running motors of all kinds; telegraphy, signalling, etc.; medical uses; electroplating; general laboratory-work, etc.

Electric lighting, however, is one of its most interesting and useful applications. It is here that its functions as a reservoir of energy become utilized to the greatest advantage.

Where lights are supplied direct from a dynamo, the machinery must have a power-capacity equal to the maximum number of lamps in a given installation; and, since the lights are usually only needed a few hours out of each twenty-four, the plant will remain idle the rest of the time. Moreover, to secure first-class results, the engine and dynamo must be of the best construction and design, steady and quick regulating, to prevent flickering. But with storage-batteries the generator is not limited as to the time or manner of working, but can prepare its supply slowly, ahead of time, during the day, in the many hours at its disposal; and, in addition to its requiring a dynamo of very much smaller size, the machinery may be of much simpler and cheaper construction, as with the battery irregularities in movement can exist without in any way affecting the quality of the light, since the current given off from the accumulators is always uniform and regular, even while the charging current is subject to marked fluctuations. The storage-battery is, in fact, an equalizer and regulator to the dynamo, besides acting as a reservoir in case of accident, which is liable to happen with the best machinery.

In all cases a direct lighting-plant can be made complete and perfectly reliable by the addition of storage-batteries, as the surplus energy, which can be stored while the dynamo is running under light load, can be utilized during the remaining hours of the day or night.

With water we cannot expect a reliable supply without providing suitable facilities for accumulating and storing certain quantities of it; and in every case we have such means of storage, whether it be a reservoir, tank, cistern, or well. With gas the supply must be yet more uncertain and unreliable without the gasometer, in which the product of the retorts can be stored ahead of the time of consumption. In the profitable and practical application of electricity we must also have a means of storing to insure an absolutely steady and uniform current, so necessary with incandescent lighting, and also to provide against any possibility of the extinguishing of the lights by failure of the generating-plant.

Another great advantage to be obtained from the use of storage-batteries is the great increase in the life of the lamps, due to the fact that the current flows with absolute steadiness at all times, thus adding from twenty-five to fifty per cent to their life, and effecting a great saving, for the renewal of lamps is one of the chief items of expense in the maintenance of an installation.

They can, for example, be charged without trouble and danger from an arc as well as incandescent circuit. Thus the electric light may be introduced in many places where a special generating-plant for charging batteries could not be employed, or where its expense would be objectionable. This permits of the introduction of incandescent lighting without too great initial cost of installation, or in the subsequent running expense.

In places where an arc circuit is already installed, the introduction of the incandescent light becomes a comparatively simple and inexpensive matter. The arc dynamo can be used in the day-time to charge the batteries, and at night to supply the arc lamps, while the stored electrical energy is used to supply incandescent lamps.

What one generation looks upon as a luxury the next regards as a necessity. Of the numerous applications of the inventions utilized during the present century for the promotion and extension of

the comforts and luxuries of life, there has been, perhaps, nothing more wonderful than the improvements in the methods of obtaining and utilizing light.

As lately as fifty years ago the candle was the chief illuminant in use. This was replaced by the oil-lamp, which was undoubtedly a great step in the way of progress. A little later this luxury made way for gaslight. But progress could not stop here. Having been educated to a proper appreciation of good light, the public, not satisfied with this improvement, demands that gas, in turn, shall make room for some other agent. The electric light has proved itself the only agency for the accomplishment of the difficulty of still further improvement.

Among its manifold advantages are,—

The great superiority and steadiness of the light.

It does not over-heat the atmosphere, nor charge it with poisonous gases, while depriving the air of its life-sustaining element, oxygen.

It also removes all danger to life and health caused by the escape of gas.

Ventilation, a matter of such vital importance to health and life, thus becomes a comparatively simple matter, the difficulties in this direction no longer increasing in inverse ratio to the amount of light used, as with gas.

The safety it offers over every other form of light, removing the ever-present danger of fire, by doing away entirely with the use of the match. By simply touching a button or turning a switch, any designated light or all the lights in a house can be lit from any part of the building. They also admit of a much more advantageous distribution of light.

The cost of insurance where electric light is used is in all cases reduced.

Its freedom from smoke and deleterious gases, which work such incalculable destruction to ceilings, walls, decorations, books, paintings, etc., makes its adoption the greatest possible saving. But, great as has been its success, its introduction into general use has been limited, as it has not been placed within the reach of all. It has been shut out from the very place where good light is most needed and appreciated, "at home," owing entirely to the method of producing it,—that of lighting direct from a dynamo.

The electric lighting of houses distant from a central lighting-station has heretofore, to a certain extent, been an impossibility, owing chiefly to the fact that a steam-plant has been necessary, and that in the production of electric light direct from a dynamo it has been impossible to obtain light except when the dynamo is running.

The operation of a steam-engine necessitates the presence of an experienced engineer, which immediately makes its production so expensive as to be beyond the reach of any but the more wealthy.

The time when light is most required in a private house is between the hours of six and ten or twelve o'clock at night, when it is almost impossible to obtain the services of a competent engineer.

The noises and vibrations attending the operation of a steam-engine have been another drawback to its introduction, for few are willing to have machinery in operation in a private house until after the hour of midnight or during the time when light is required.

There has been no means of producing electric light with the direct lighting method so that light may be available at all times except by the running of a dynamo continuously, and, unless light can be available at all times, it fails to compete with gas.

The storage-battery, however, seems to overcome all these difficulties, and to solve the problem of incandescent lighting in isolated cases.

In the course of some remarks recently made before an electric-light association by a prominent New York electrical engineer, the importance of storage-batteries in electric lighting was very clearly shown in the following: "I would call the attention of the members, for instance, to the lighting of private residences which are detached, country residences, summer residences, and large mansions. I believe that here the storage-battery has a sphere which it will hold as its own, for the reason that the direct system of lighting of to-day does not afford all the requisites of a perfect application of electricity for lighting. It has not supplanted gas, and you will find

that wherever isolated plants are in use to-day they still have gas. Now, I do not consider that we can look upon isolated lighting as a success until we see it drive gas out altogether. To do that, we must have electricity 'on tap' for twenty-four hours a day, the same as gas, and I can conceive of no system by which this can be done successfully except one involving the use of storage-batteries as an accessory, if nothing more."

A storage-battery can be charged with the use of almost any form of power during the hours of the day, and in many instances energy now running to waste may be utilized in laying up a supply for night use.

One of the interesting developments in this connection is the prominence of the gas-engine as a producer of electric light. This power seems to be particularly fitted for work in connection with storage-batteries. The operation of these engines is so simple that they can be cared for and run by the employees of almost any house. The power is always available. The gas in the engine is ignited by a spark from the battery, and, in fact, can be started by simply turning a battery switch, using the dynamo for a moment

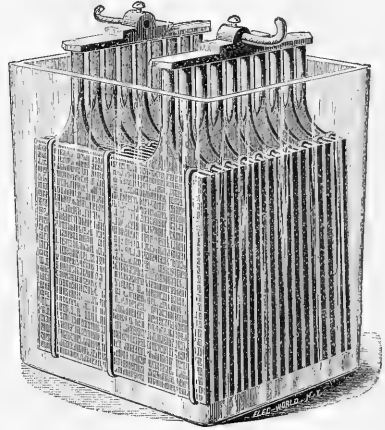

THE JULIEN STORAGE-BATTERY.

as a motor to bring the engine up to speed. Thus by the simple operating of a switch the entire plant is set in motion. The battery is charged during the day, and at night, when the engine is shut down, enough energy will have been stored to supply the house with light for the entire night.

The accompanying illustration represents one of the most interesting displays at the American Institute Fair this season, the installation of the Julien Electric Company, showing the application of storage-batteries to the lighting of private residences in connection with a Baldwin gas-engine and a United States dynamo. The plant consisted of a 4-horse-power gas-engine coupled to a 30-light dynamo and 36 cells of Julien battery. There were in the exhibit some 95 16-candle-power lamps, in addition to two $\frac{1}{2}$ -horse-power electric motors used for operating a fan and sewing-machine,—another application to family needs. The current from the battery can also be used for pumping water, the running of electric bells, burglar alarms, and other light work. The dynamo charges the battery during the day; and at night, when the full number of lights is turned on, the dynamo takes care of 30 lights, and the remaining 65 are taken from the accumulators. It will thus be seen, that, in addition to serving as a reservoir to be called on when the plant is not in operation, by the running of the dynamo, and at the same time discharging from the battery, a largely increased number of lamps is available, thus reducing very considerably the amount of power necessary to be introduced. It is generally acknowledged that light derived from storage-batteries is of greater steadiness than that produced direct, thus increasing considerably the life of the lamps.

The cell employed was the type 19 C of the Julien Company, weighing complete about 44 pounds, which is rated by that company as having a capacity of 200 ampère-hours, and the rate of discharge given is 30 ampères. It will be seen, however, that, as these lamps take about $\frac{1}{3}$ of an ampère each, the batteries were being discharged at about twice their normal rate, and, where occasion required, the engine was stopped and the batteries supplied current for the entire plant, thus discharging at almost three times their nominal rate.

This is a particularly creditable showing for these batteries. The principal difficulty heretofore in the use of accumulators has been that they have not been permitted to be discharged at a greater rate than from about one-tenth to one-eighth of their capacity, whereas in this exhibit they were regularly required to deliver their full capacity in about four hours.

The cells were in use from the commencement of the exhibition, the 1st of October, until Dec. 15, and did not in that time require the least attention on the part of the company, the plant being run entirely by a man in charge of the gas-engines, who, until the opening of the fair, had never been in charge of an accumulator plant.

The lights were burned four hours each night, which, discharging at the rate of about 60 ampères, and occasionally at 80 to 85, made a total of 250 ampère hours taken out, while the rated capacity (discharging at the nominal rate) is but 200 ampère hours. This is an indication of the large amount of reserve energy there is always on hand in case of an accident or stoppage of the generating-plant, or in case of an emergency.

A BLIZZARD MEETS AN ELECTRIC ROAD.

RECENTLY one of the severest tests to which an electric railroad can be subjected was experienced by the Davenport Electric Line, installed by the Sprague Electric Railway and Motor Company of New York, at Davenport, Io., and one which proves most conclusively that an electric railway can be operated even under the most adverse conditions of weather. The blizzard, which had been howling about the Dakota prairies during the first part of the week, and getting up its strength by snowing in the territory farmers, decided to come south, and on Jan. 9 struck the city of Davenport.

The snow, which was of the heavy damp variety, fell all day, and covered the streets to the depth of from four or five inches to one foot on a level, and in several places caused deep drifts over the line of the electric railway. In spite of this, the cars on the electric line kept running uninterruptedly, carrying a large number of passengers, and proving conclusively that no amount of snow could prevent the cars from running on schedule time. The president of the road, Mr. W. L. Allen, was greatly pleased with the signal triumph of the Sprague people, who had told him in the autumn that snow could not interfere with the operation of the road, and is enthusiastic over electric railways.

This road has been in operation about four months, and has been giving very great satisfaction to the management and citizens of Davenport, who have had a much better service since its installation than they ever had while the road was being operated by horses. The cars move faster, are under quicker and more perfect control, and are much more easily managed than the cars drawn by animal power. The regular Sprague overhead system, with small No. 6 silicon-bronze wire as a working conductor, is in use upon this road. All the latest devices and improvements adopted by the Sprague Company for facilitating the operation and increasing the convenience of their electric roads are in use here.

Among the principal points of excellence of the Sprague system of electric railway, may be mentioned the system of conducting current to the cars by means of a working conductor, separate from the main conductor, but connected to it at intervals by automatic cut-outs, by which an accident on any portion of the line does not interfere with the remainder of the road; the use of flexible suspension for the motors, preventing accident from sudden strain; and the method of controlling the motors from either platform without the use of idle resistance.

TESTING A PNEUMATIC DYNAMITE GUN.

ON Saturday last a test was made of the capabilities of a pneumatic gun of fifteen inches bore, forty feet in length, intended to throw a shell containing 700 pounds of dynamite and nitro-gelatin. Two shots were fired, when, owing to the leakage of an air-valve, the experiments were postponed to some future time. As far as the trial went, the results were satisfactory. A mile from the gun, which was located at Fort Lafayette, in the Narrows, New York Bay, a rectangular space 50 by 100 feet was marked off in the waters of Gravesend Bay by four buoys. The first projectile from the gun passed about 250 yards beyond the target, though it was an excellent line shot. Its course was easily followed by the unaided eye from the moment it left the gun until it entered the water. It passed through the air as though shot from a rifled gun, without an oscillation or a "wobble." It exploded a moment after striking the surface, throwing up the water, like an immense fountain, from 100 to 200 feet into the air. This first projectile contained 170 pounds of dynamite.

The second projectile, containing 200 pounds of dynamite and 300 pounds of nitro-gelatin, a larger charge than had ever been used before, fell short of the mark, but the effects of its explosion were tremendous. A reversed Niagara, of water, mud, and stones, shot perhaps 200 feet into the air. It seemed as though a water-volcano had broken forth in Gravesend Bay.

The reason for this shell not reaching the target appeared to be that there was some defect in the tail-piece, which is depended upon to keep it from oscillating or wobbling in its flight. Some part of this tail-piece was evidently injured in leaving the gun, and the consequence was that the longitudinal axis of the projectile (which was six or seven feet in length) deviated from the line of flight. It swung through an angle of about forty degrees, back and forth, while describing the arc of flight, the oscillation decreasing as the projectile approached the water.

Further tests of the gun are promised in the near future, and they will be watched with interest, as the dynamite gun is destined to take an important place in the warfare of the future.

THE RISLEY AND LAKE COMPOSING-MACHINE.

THERE is now on exhibition at No. 22 Spruce Street, this city, a machine intended to dispense with the use of type in certain kinds of printing. It is the invention of Messrs. Risley and Lake; and though only an experimental machine, and therefore somewhat imperfect in many of its details, it does its work speedily and well. The printing done by it is not as perfect or as pleasing to the eye as ordinary letterpress work, but is good enough to satisfy the requirements of that important branch of the printer's art known as law printing, in which small editions of lawyers' briefs, legal arguments, evidence, etc., are desired in a few hours' time.

This machine, in its present crude but very promising stage of development, is shown in the accompanying illustration. As a satisfactory description of it cannot be given unless the machine be seen in operation, only a few of its features will be touched upon here. Though not so complicated as the engraving makes it appear, still many of the mechanical movements involved are so novel that they must be seen before they can be readily understood.

It will be perceived that there is a key-board like that of an ordinary type-writer, the use of which is obvious. There is a key for each character used. These characters are all cast or cut on one cylindrical shell or sleeve, in which feature the machine resembles the well-known Crandall type-writer. This type-shell may be seen, in the illustration, at the centre of the machine, immediately to the rear of the key-board, and in front of the sheet of paper upon which the printing is to be done. One peculiar feature of this machine is, that the printing does not begin until the keys for about fifty characters have been struck, so that the operator is always at least a line ahead of the impressions as they appear on the paper. The keys, instead of acting directly upon the printing apparatus, act upon a set of pins, which are carried in a revolving disk; each key, when depressed, setting its appropriate pin in position for actuating the printing mechanism when the disk shall have carried it around to the proper point. In this way there are always stored

up, as it were, ready for use, fifty or more characters, and these are made to appear upon the paper, in proper place and order, by the automatic action of the machine, even after the operator ceases work at the key-board.

A unique feature of the invention is that by which the lines are "justified;" that is, lengthened or shortened to conform to the width of the column or page. To do this, when movable types are used, as in ordinary type-setting, the compositor, when the line is nearly completed, puts thicker or thinner spaces between the words. Otherwise the lines would be unequal in length, presenting a ragged appearance, similar to that of type-written work. By an ingenious device upon this machine, when a sufficient number of words to approximately fill a line have been registered or "pinned" upon the revolving disk, the justifying or spacing between the words is done automatically; and when the words subsequently appear upon the paper, they fill the line as accurately as do the words in

city, who are now erecting extensive workshops for its manufacture. The chief moving spirit in the enterprise of bringing it to the front and putting it upon a commercial basis is Mr. Edward F. Underhill, official stenographer of the New York Surrogate's Court, who has had it in use in his office for several months, with highly satisfactory results.

METHYLATED ALCOHOL.¹

THE employment of alcohol so adulterated as to render it unfit for use as a beverage, free of tax, in the arts and manufactures, has lately been receiving attention by Congress. To prevent fraud on the revenue, the degree of adulteration that would be permitted should be governed by two considerations,—first, the minimum amount of adulterant that should be added to make the subsequent purification of the alcohol unprofitable; and, second, the maximum

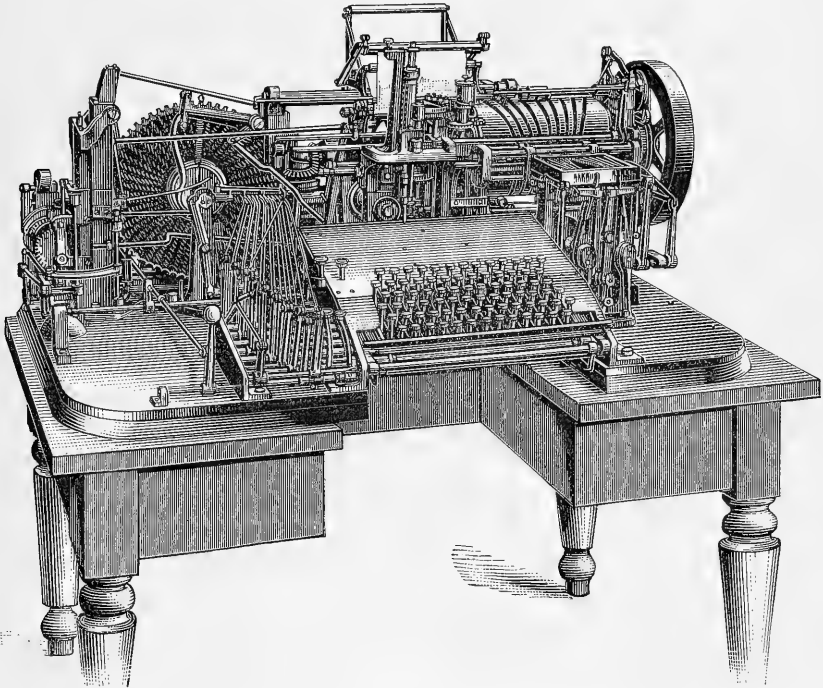

RISLEY AND LAKE COMPOSING-MACHINE.

this line, and the spacing between the words is as even as it could be made by the most expert compositor. In fact, the spacing is, and must of necessity be, mathematically correct.

The reproduction of the work done on the machine now on exhibition is accomplished by lithography. The printing by the machine is done with lithographic ink on paper specially prepared. The impression is then transferred to stone in the usual manner, and the desired number of copies struck off. The first printing or composing on the machine is done in less than a fourth of the time required when movable types are used, the ordinary speed being from twenty to twenty-five words a minute. The cost of transferring to stone is said to be less than the "making up" of forms for the press in ordinary printing, and there is no "distribution" of type.

This machine has also been tested with a view to making matrices for the casting of stereotype plates, but the experiments have not been carried sufficiently far, as yet, to determine what may be accomplished by it in that direction. The patents covering the machine are controlled by the Graphic Process Company of this

amount of adulterant that can be added without rendering the use of such adulterated alcohol unsuitable in the arts and manufactures.

Compounds known as methylated spirits, made by adulterating pure grain spirits, free of tax, with wood naphtha (methyl alcohol), are more expensive than such pure spirits, because the adulterant is, contrary to what is usual in such cases, more costly than the article adulterated.

For most manufacturing purposes, the addition of any amount of adulterant to grain alcohol must be regarded as just so much added useless matter. Besides, there is no purpose for which methylated spirits is used where the employment of grain alcohol would not yield both a cleaner and better product; in addition, there are many cases in which methylated spirits cannot be used at all.

Let us see what has been done in this matter in England and Germany, where laws and regulations on the subject have been enacted.

¹ Paper read before the Chemical Society of Washington, Jan. 10, 1889, by Edgar Richards.

Great Britain.

In England, according to the definition of their regulations and law, "the spirits must be plain spirits or unsweetened foreign spirits, of not less strength than 50 per cent over proof, or rum of not less strength than 20 per cent over proof, and must be mixed with at least one-ninth of their bulk of wood naphtha. This mixture is termed 'methylated spirits.'" Accordingly, 10 per cent is the amount of added impurity.

The Board of Inland Revenue only permits the use of a decidedly impure and crude wood naphtha for this purpose, of a not "less strength than 60 over proof," and which must not be used until a sample has been submitted and approved by the chemical department of Somerset House. Until the necessary approval has been obtained, the naphtha is kept under official lock and key, and only allowed to be used for mixing under certain regulations; and the whole quantity, 100 gallons, "must be drawn off and used before any other naphtha is conveyed into the vat." "Naphtha disapproved by the board must be immediately removed from the naphtha warehouse."

The mixing must be done in the presence of officers of inland revenue, and "500 gallons of methylated spirits is the least quantity which may be prepared at one time in a mixing-room, whether the spirits used be British or foreign spirits." "The mixing must take place in a vat of sufficient capacity to admit of the spirits and naphtha being thoroughly mixed."

Methylated spirits is "supplied to such persons only as undertake to use it in the arts and manufactures, subject to the board's approval," and on entering into bond in the sum of from £200 to £1,000 penalty, depending on the annual consumption which they propose to employ. Scientific societies and hospitals who obtain the methylated spirits for scientific purposes are not required to give a bond.

All persons authorized to use methylated spirits are warned that they are not at liberty to purify the spirits in any manner whatever. "No person can legally use methylated spirits, or any derivative thereof, in the manufacture, composition, or preparation of any article whatever capable of being used either wholly or partially as a beverage, or internally as a medicine." It may be used, however, "in the preparation of sulphuric ether, chloroform, hydrate of chloral, soap, compound camphor, aconite, and belladonna liniments," without coming under the foregoing prohibition.

The premises of all users of methylated spirits are liable to inspection of the inland revenue officers at all times.

The following table gives the total quantity of methylated spirits produced in Great Britain since 1881, taken from the annual reports of the commissioners of her Majesty's inland revenue:—

Methylated Spirits.

1881.....	1,762,559	gallons.
1882.....	1,991,765	"
1883.....	2,100,765	"
1884.....	2,236,962	"
1885.....	2,334,935	"
1886.....	2,477,798	"
1887.....	2,673,375	"
1888.....	2,757,402	"

This table shows a steadily increasing consumption.

Canada.

In Canada, where a similar law to England was for many years in force, the government permitted methylated alcohol to be manufactured in bond for use in the arts, and to be withdrawn upon the payment of an excise-tax of fifteen cents per gallon. Twelve gallons of wood naphtha of not less than 60 per cent over proof were added to 100 gallons of grain alcohol. Subsequently the Inland Revenue Department ascertained that such spirits were being demethylated and rendered potable, thus causing a serious loss of revenue. The law was therefore repealed, and the Department of Inland Revenue undertook to supply the trade with a substitute, composed of 25 per cent of wood naphtha and 75 per cent grain alcohol, which is supplied only to varnish-makers and other persons engaged in the mechanical arts. The persons using this grade of methylated spirits give bonds, in the sum of \$2,000, that such spirits

shall be used solely for the purposes mentioned, and in the premises described in their application. An inferior grade, consisting of equal parts of wood naphtha and grain alcohol, is supplied the trade without any restrictions as to its use (see letter from Assistant Commissioner W. J. Gerald, of Oct. 25, 1888, published in the "Annual Report of the Commissioners of Internal Revenue, 1888," p. cxx.).

Germany.

The German spirit law, and the regulations issued to carry it into effect, permit of a sliding scale of adulteration, depending on the designated use of the "denaturised spirits."

For most purposes, a mixture of two parts of wood naphtha and one part pyridine bases to one hundred parts of alcohol is permitted. The wood naphtha is submitted to certain prescribed tests in regard to color, specific gravity, boiling-point, miscibility with water, contents of acetone, and capacity for absorbing bromine. The pyridine bases are likewise examined for color, behavior towards cadmium chloride, boiling-point, miscibility with water, contents of water, and volatility.

The regulations that have been issued from time to time have variously amended those preceding them. Those of June 21, 1888, are the latest, and several of the provisions contained therein did not come into force till the first of this year.

Makers of the general denaturising agent are permitted to add "40 grams of oil of lavender or 60 grams of oil of rosemary to every litre." Such addition has likewise to reach a prescribed standard.

"It is illegal to remove, or partially remove, the denaturation agent, or to add substances whereby the taste or smell of the denaturised spirits is altered." The selling or placing on sale of such purified spirits is likewise declared illegal.

Manufacturers may also use "five parts of wood naphtha instead of the general denaturation agent or pyridine bases" under certain regulations, and may sell the same "to persons engaged in industrial pursuits."

Varnish and polish makers may use "0.5 per cent of oil of turpentine" for this purpose, and may likewise sell varnishes and polishes so prepared to the trade. In "the manufacture of glazes for brewers' use the denaturation may be made with 20 per cent of a solution of one part of shellac in two parts of 95-per-cent alcohol. The alcohol used for such solution is to be free of tax."

In "the preparation of the alkaloids, medicinal extracts, chloroform, iodoform, chloral hydrate, sulphuric ether, acetic ether for technical purposes, collodion, tannin, salicylic acid and its salts, white lead and acetates, the alcohol may be denaturised by 0.5 per cent of oil of turpentine, or by 0.025 per cent of animal oil, or 10 per cent sulphuric ether."

"For making colored varnishes, 0.5 per cent of oil of turpentine, or 0.025 per cent of animal oil," is permitted; and for alcohol used in the "analysis of sugar-beets in sugar-factories, 0.025 per cent of animal oil" is the quantity prescribed for denaturation.

"For the preparation of acetic ether intended for technical purposes, freedom from tax can only be granted for the alcohol to be used under condition that besides the prescribed denaturation of the alcohol," as already mentioned, the ultimate destination of the acetic ether must be indicated, and will be controlled by suitable regulations.

The "animal oil, oil of turpentine, sulphuric ether, and shellac solutions intended to be used as denaturation agents, must satisfy the prescribed tests," and be submitted to an officially appointed chemist, and be approved by him before they are permitted to be used for the purpose. The expense of such test is borne by the manufacturer.

"For the preparation of vinegar, alcohol may be denaturised by 200 per cent of acetic acid of 3 per cent, or by 30 per cent of acetic acid (vinegar) of 6 per cent, or by 70 per cent water and 100 per cent beer." It is also allowable to use, "besides the prescribed quantity of acetic acid (vinegar), 100 per cent of pure genuine wine instead of the beer and water."

Alcohol of "less than 80 per cent" is not permitted to be treated, and "not less than 50 litres" must be treated at a time. The mixing must take place under the supervision of two revenue officers.

United States.

The bill now before Congress contemplates: 1. The use of large, bonded warehouses for the storing exclusively of spirits "of not less than 180 per cent proof." 2. The removal of such spirits free of tax from the bonded alcohol warehouses to bonded storerooms, to be "used in manufacturing establishments, in the industrial arts, and in the manufacture of articles, preparations, compounds, acetic and other acids, and medicinal drugs or chemicals." "The manufacture of tinctures, proprietary articles, wines, liquors, cordials, bitters, or other alcoholic compounds which are used or sold as beverages," is excluded from the provisions of the act. "The commissioner of internal revenue, with the approval of the secretary of the treasury," is to make and enforce all needful regulations. The bonds for the alcohol warehouses are not to be in a less sum "than \$100,000;" and those for storerooms to be not "less than \$5,000;" all operations conducted in such bonded establishments to be under the supervision of revenue officers, as is now customary in all distillery warehouses. 3. The proprietor of any bonded alcohol warehouse may methylate such spirits free of tax, so as to cause them "to be unfit for use as a beverage," under prescribed proportions and regulations; and such methylated spirits may be withdrawn from the warehouse upon a permit issued in due form by any person who has complied with the provisions of the law, and filed the necessary application and bond with the collector of internal revenue in whose district the methylated spirits are to be used; the sale, removal, transportation, and use of such methylated spirits to be under prescribed regulations and bonds. Heavy penalties are prescribed for the purification, by any means, or the use, of such purified methylated spirits.

It will be seen from this review of the legislation on the subject, that the purification of methylated spirits is made unlawful, from which one might conclude that this process does not render the spirits altogether unfit for drinking-purposes when properly purified.

Having been requested by the commissioner of internal revenue to make experiments for the purpose of ascertaining whether such spirits could be demethylated, the experiments were made, and my report on the subject was published in the "Annual Report of the Commissioner of Internal Revenue," lately issued.

I now beg leave to submit to the members of the society some of the samples of distillates and artificial liquors produced, and let them judge for themselves how far I have succeeded in making a drinkable compound.

Ten per cent of the methyl alcohol was used for adulteration as being the largest amount known to me, when the experiments were carried out, as being legally permitted. The provisions of the Canadian law I did not learn of till after my report was written. As soon as I have some leisure, I intend trying to purify 25 and 50 per cent of adulteration.

The loss was, for the reasons stated in my report, much greater than would happen on a commercial scale; and, as long as there is a high tax on distilled spirits, a large loss might take place in purifying methylated alcohol, and yet render the illegal process profitable enough for unscrupulous persons to take the risk of detection.

Since the bill has been introduced a strong opposition to its provisions has been developed in the large wholesale and retail drug trade, and the *Oil, Paint, and Drug Reporter* has lately been devoting a great deal of space to the views of the most prominent dealers. They are of the general opinion that alcohol should be free to all, or not at all; that the small druggist who now prepares a great many, if not most, of his medicines, etc., would be driven out of the business, as he could not afford the bonded storeroom, etc., and be compelled to purchase from a few large firms who could readily afford to comply with all the necessary regulations; and, lastly, that the supervision at all times of revenue officers over their business is distasteful to them. A great many of them state, that, even if the alcohol was methylated, it would most certainly have to be purified before they could make use of it.

The great supporters of the measure are of course the alcohol-producers, who see in its provisions an increased market for their product.

ELECTRICAL NEWS.

Dissipation of Fog by Electricity.

SOME remarks in the editorial columns of the *London Electrician* have called forth a letter from Professor Lodge on the subject of the dissipation of the London fogs by means of electric discharges. At the Montreal meeting of the British Association, in 1884, Professor Lodge described some experiments in which he condensed smoke by means of a brush discharge from points connected with a static electric machine. The subject was an interesting one, and attracted considerable attention at the time; but it seems that no experiments on a large scale have since been attempted. A number of possible applications have been suggested, — for example, it has been proposed to use an electric discharge to dissipate the dust-particles in flour and other mills, which have been the cause of several disastrous explosions, — but the efficacy of the plan has not been tried. In the letter referred to, Professor Lodge states that he has been deterred from experimenting chiefly on account of the great initial expense necessary for a trial on a large scale, — an expense which he estimates to be in the neighborhood of five thousand dollars. As to the form of experiment, he is not sure that a battery of an enormous number of cells would not be the most likely plan. So far, the largest experiment that Professor Lodge has made has been the clearing of a smoke-filled room; but the results were so encouraging, that he does not despair of condensing the fog in a stagnant atmosphere. He has applied to the trustees of the Elizabeth Thompson fund in this country for a grant of five hundred dollars with which to continue his work, but has not yet heard the result of his application. The matter is a most interesting one. We have an entirely new field for electrical application, with a very substantial promise of reward for success. There are a number of possible applications of the process, — the clearing of smoke from tunnels, the dissipation of dust-particles in mills, and the general abatement of the smoke nuisance that is so unpleasant in manufacturing towns.

TRIALS OF THE SUBMARINE BOATS "GYMNOTE" AND "PERAL." — At a recent meeting of the French Academy of Sciences, Admiral Paris read a short paper on "The Submarine Boat 'Gymnote,'" which we lately described. He was most enthusiastic as to its success, and in the course of his remarks said, "In short, we are able to say that the 'Gymnote' moves and steers equally well above or below the surface, that it can be kept accurately at the desired depth, that its speed is all one could expect, that respiration is unimpeded, and that down to a certain depth it is easy to see. M. Tédé says that Captain Krebs's electric motors are marvels of lightness and precision, and that this important part of the boat has been carried out in a most masterly manner. The energy available amounts to 240 horse-power hours. So complete a success would have been impossible without the scientific ingenuity and minute care which M. Romázoff, naval engineer of Toulon, brought to bear upon every detail. Here, then, we have a solution of the submarine-boat problem. The first step has been taken. Better work will be done in the future. But, even as it is, the 'Gymnote' is capable of rendering good service." From *Engineering* we take the following: "The new Spanish submarine torpedo-boat 'Peral,' which has lately been tested with much success, is 72 feet long by 9.5 feet in diameter. It is fitted with a secondary battery of 600 cells, which supply the current to five electro-motors, two of which are of 30 horse-power each, and drive the propellers: the other three are only of 5 horse-power each. The boat has a speed of 11 knots on the surface, and 10.5 knots below. It can remain submerged for two days before the air requires to be renewed. It will be armed with Whitehead torpedoes." With the recent partially successful experiments with directable balloons, and these latest experiments with submarine boats, we may expect novel developments in warfare.

NEW RECKENZAUN TRAM-CAR. — The principal novelties in this car consist in the method of gearing the motors to the car-axles, and in the employment of a form of secondary battery on which Mr. Reckenzaun has been working for some years past. The ordinary practice of connecting the motor-shafts and car-axles is through two pairs of spur-gears, the ratios of the diameters giv-

ing the necessary reduction in speed, — about one turn of the car-wheels to ten or twelve of the motor. A single pair of gears would be sufficient for light work, but for climbing hills a single reduction would make the strain on the teeth too great. The efficiency of spur-gears is very great, and, when properly constructed, there is very little noise or jar. A much more compact arrangement, though a less efficient one, has been adopted by Mr. Reckenzaun. He uses a simple worm gearing, where the motor-shaft and car-axle are at right angles to each other. Such an arrangement has been generally avoided because of the supposed great loss through friction. From his own experiments, however, Mr. Reckenzaun concludes that the losses are greatly overestimated, and by taking especial care in the lubrication he has obtained efficiencies that compare favorably with the efficiency of spur-gears. But it is in the storage-battery that the greatest interest of the system lies. It does not seem to be any great improvement over the present battery in weight — the cells on a car weigh about two tons — or in efficiency, but it is claimed that the durability will be greater than that of the ordinary type. The plates are made by forming by pressure cylinders of active material, a sixth of an inch in diameter, and about an inch and a quarter long, putting them in a mould and casting lead around them. The cylinders are only about a tenth of an inch apart, while the thickness of the lead in which they are embedded is one-eighth of an inch. The advantages of this form of plate lie in the fact that the active material is held firmly in its place, and that the greater part of the expansion is in the direction of the length of the cylinders: so the chance of buckling is less, while a large active surface is offered to the action of the acid. The total weight of the car, with thirty passengers, is about seven tons and a half, and about five electrical horse-power is required to draw it on a level at a velocity of seven to eight miles an hour. On a hill with a grade of five per cent, the motors absorb twenty electrical horse-power. The car described has been built by Messrs. Stephens, Smith, & Co., and is for use in Melbourne, Australia.

SNOW-STORMS ON ELECTRIC ROADS. — The winter has thus far been so mild that electric railroads have hardly had a fair test as to their capability of working under adverse circumstances. One snow-storm in St. Joseph failed to stop the electric line there; and now we have news of a blizzard at Davenport, Io., through which the Sprague cars ran without interruption. In this last case the snow — of the heavy, damp variety — covered the streets to a depth of four or five inches, with drifts in places across the tracks. While this is satisfactory enough, it must be remembered that it is not the wet, slushy snow that is most to be feared, but the dry variety, that cakes on the track and prevents contact being made between the wheel and rail. The only safeguard against trouble from this last cause is to keep cleaning-cars going as long as the snow-storm continues. There is another difficulty, especially when a heavy overhead wire is used, and this is from the formation of a coating of ice or sleet, preventing the trolley from touching the wire. While in the two cases cited there has been nothing but encouragement, yet there have been rumors of troubles that occurred at Washington, at Lynn, and perhaps at Brockton, on account of snow and ice. These were no doubt caused by insufficient experience, and from neglecting common precautions, and were only small matters at the most, but they at least show that precautions must be taken.

APPLICATION OF ELECTRIC MOTORS TO MINING. — At the Drane Colliery, near Osceola, Clearfield County, Penn., Mr. F. M. Lechner has devised a most interesting application of motors to mining-work. A ten-horse-power Sprague motor is mounted on a truck running on rails, so it can be easily moved from one place to another. The weight of the machine is something less than a thousand pounds. The cutter to be operated is set in position in the space to be cleared, and is connected to the motor by a $\frac{5}{8}$ -inch rope belt, movable pulleys on jack-screws being so adjusted that the cutter can be operated at any angle from the motor. The latter is about thirty feet from the cutter, the tension of the belt being adjusted by moving the truck one way or the other. The machine runs easily and cuts well. By this plan three cutters can be worked from one motor, two being adjusted while the third is at work, the motor being moved from one to the other as it is needed. It was

found, on a preliminary trial of this apparatus, that by its use two men could excavate one hundred tons in ten hours, and that they can move the cutter as often as desired without any auxiliary aid. The efficiency of the dynamo and motor are each over ninety per cent, and, allowing ten per cent loss on the line, between seventy and seventy-five per cent of the power delivered to the dynamo can be called on at the motor for work. It has been estimated that the cost of equipping a mine with electric power is only half of that of compressed air, while the working expenses are about in the same proportion.

SCIENTIFIC NEWS IN WASHINGTON.

Some Habits of the Omahas. — Electrical Conductivity of Glass. — Fish Commission Experiments. — The Woman's Anthropological Society. — The Survey for Irrigation. — Indian Relics from Florida.

Some Habits of the Omahas.

The following statements have just been made by an Omaha Indian (Samuel Fremont) to Rev. J. Owen Dorsey: —

The Omahas used to blow the smoke of the pipe in six directions, up, down, and to the four winds, using a prayer in each case. The exact order in which the winds were addressed has been forgotten; but the smoker could pray to the being above first, if he wished, and then to the being below, or *vice versa*. The earth itself was spoken to as if it was a person. The formula was as follows: "One of you lies on his back [i.e., the earth], the other one sits above: both of you help me!" Then followed the petition, "Oh, ye who cause the four winds to reach a place, help ye me!"

White people think that the Omahas knew nothing about Wakanda (a higher power, the Mysterious Power) before the meeting of the two races; but that is not so. They had many old sayings, used before they met the white people, such as, "Wakanda has decided for him his own (child, descendant, etc.)." "Wakanda knew," and "Wakanda seems to have aided him." These were employed when an Indian met with unexpected good luck. But the Pawnees had many more sayings about Wakanda than the Omahas had.

Before the advent of the white people, the Omahas used to get the wild honey, which they called "bee-dung." Its present name is "bee-gum." They put the comb in a kettle, in which they let it melt and boil, skimming off the impurities. They used the sirup as the white people do molasses. Unless the bees were troublesome, they did not smoke them when they took the comb.

Electrical Conductivity of Glass.

Dr. C. Barus has just completed a protracted investigation on the effect of stress (traction torsion) on the electrical conductivity of glass at different temperatures between 100° and 360°. The question is of unique importance, because the conductivity of glass is wholly electrolytic. He finds that stress of the kind given materially increases conductivity; whence it follows that the time-rate at which molecular reconstruction takes place in glass is definitely greater when this substance is longitudinally extended or twisted than when it is free from such strain. The result has a direct bearing on the viscosity of the solid.

Fish Commission Experiments.

Marshall McDonald, United States fish commissioner, is making a comprehensive experiment in salt and fresh water aquariums. He has already constructed several aquariums on the lower floor of the building, and stocked them; and he is now building a large one, 120 feet long, under a separate roof. The commissioner said to the correspondent of *Science*, "I am going to bring the seashore to Washington, and assemble here a full representation of our marine life." He has sixty or seventy species already sporting in salt and fresh water tanks, one of the latter containing specimens of the earliest type of fresh-water fish, — the ganoids. •

The Woman's Anthropological Society.

One of the active scientific societies of Washington, and one whose work is of peculiar interest in that it is carried on solely by the sex sometimes supposed "incapable of generalizing," is the Woman's Anthropological Society. Despite the temporary retire-

ment of the president, Mrs. T. E. Stevenson, who is well known for her personal work among the Zuni, the society enters upon the fifth year of its existence with undiminished enthusiasm and vigor; Mrs. Sybil A. Carter (wife of the Hawaiian minister) and Miss Florence Spofford acting respectively as president and secretary. Two meetings were held during January. On the 5th the subject of discussion was "The Evolution of a Community (Amana)," as presented by Mrs. Anita Newcomb McGee. The author of the communication has been for several months engaged in investigating the communistic societies of the United States, nearly all of which she has visited. The more general results of her studies were laid before the American Association at Cleveland in August last. Some of the elements of success or failure in communistic organizations are obscure, and have seldom been perceived by writers on the subject; and these Mrs. McGee sought to develop and set forth by a study of the origin, growth, and relations to environment at every stage, of the most successful American community. The conclusions were in line with those stated at Cleveland, and summarized in the *American Naturalist* for September last. The meeting on the 19th was occupied in the presentation of a communication on "Russia and the Russians" by Mrs. Hunt, widow of the late minister to the Muscovite dominion. The habits, customs, and beliefs of the various classes of Russia were vividly portrayed; and the skill of artificers in certain Russian villages in the production of enamelled silver and other wares, etc.—arts handed down from generation to generation in Oriental fashion, and unknown elsewhere,—was illustrated by the exhibition of a collection of silver and fictile ware and unique textile fabrics.

The Survey for Irrigation.

Professor Thompson announces to the correspondent of *Science* that topographic parties of the United States Geological Survey engaged on the irrigation survey in New Mexico have completed their field-work for this season, and disbanded at Santa Fe.

An area of 3,500 square miles in the drainage basins of the Jemez and Rio Grande has been surveyed with sufficient detail to construct a map on the scale of two miles to an inch and contour interval of fifty feet.

This work has been under the immediate charge of Mr. Arthur P. Davis, who returns with most of his force to Washington to prepare final maps. One party, however, under charge of Mr. R. H. Phillips, will continue work in the lower Rio Grande valley, near El Paso, Tex., during the entire winter. A number of eligible sites for reservoirs and diverting dams have been located. It is estimated that sufficient water can be stored in the mountains about the head waters of the Jemez River to irrigate 150,000 acres of land where now the waters only serve about 4,000 acres.

Indian Relics from Florida.

Dr. Thomas Featherstonhaugh, a grandson of the famous pioneer geologist, has just returned from a visit to Florida, and has brought back an interesting collection of aboriginal remains. He thoroughly examined a mound of damp sand on the shore of Lake Apopka, about the geographical centre of the State, and farther south than any previous researches of the kind. The mound was fifty feet in diameter and fourteen feet high, and was covered with a dense growth of palmetto and other trees. It was found to be full of fragrant bones and pottery, so numerous that Dr. Featherstonhaugh estimates that there could have been no less than four hundred bodies deposited there. A few Venetian beads near the top indicated intrusive burials, but below four feet there were no evidences of any intercourse with whites. Four shapely hatchets were recovered, also a charm-stone, and numerous specimens of decorated pottery. The whole find was presented to Major Powell, and by him turned over to the Museum.

NOTES AND NEWS.

STANLEY'S letter to Tippto-Tip, which was recently published in the daily papers, contains no new information besides that which was conveyed in the recent telegrams. Stanley had succeeded in reaching Emin, and had returned to the Kongo in order to look after his rear guard. He was anxious to see Tippto-Tip, and invited

him to meet him at some distance from the Kongo, where he encamped. He intended to return to Emin. It was stated before, that Stanley's letters were detained for some unexplained reason at Stanley Falls Station, while the latest telegram said that there were no other letters besides the one mentioned, addressed to Tippto-Tip. The full information sent from Zanzibar has again proved incorrect, as was expected. The report of the arrival of a letter from Stanley had evidently been telegraphed to Zanzibar by way of London, where it was amplified and falsified, and came back through Reuter's agency. No reports on events in the Equatorial Province or on the upper Kongo coming from this source can claim any serious attention.

— The original portrait of Washington (right side of the face) by Gilbert Stuart, long thought to have been destroyed by the artist, seems to have been recognized in the hands of Dr. W. F. Channing of California, who inherited it from his distinguished father, Rev. William Ellery Channing, who obtained it from his uncle, Col. Gibbs. It is understood that both New York City and Chicago have made offers for it, to hang in their art galleries, and its ultimate destination is doubtful.

— Surgeon-Gen. Hamilton has had one of his expert assistants, Surgeon Kinyoun, carry on a series of experiments as to the effectiveness of new disinfectants. Phosphorus was the one taken for the chemical tests, with litmus-paper and micro organisms; and the conclusions arrived at were, "1st, that phosphoric pentoxide is a disinfectant to surfaces only; 2d, it has no penetrating power, and is altogether unfit for fumigation of any thing where penetration of the agent is desirable." So perishes the hope that the fumes of phosphoric pentoxide would be useful in extirpating the bacteria of disease.

— On the evening of Jan. 23 the Mathematical Section of the Philosophical Society held its forty-ninth meeting, elected officers, and heard and considered these papers: "A Brief Control for General Solutions of Normal Equations," by A. S. Flint; "On Napier's Logarithms," by Artemas Martin; "General Perturbations of the Minor Planets," by W. F. McK. Ritter.

— A bill has been introduced in the Legislature of Nebraska to provide for a geological survey of the State with special reference to economic purposes. It proposes co-operation with the United States Geological Survey. The professor of geology in the State University at Lincoln is made *ex-officio* State geologist, and the sum of five thousand dollars for each of two years is to be appropriated for the work.

— The War Department has granted to the Smithsonian Institution the privilege of erecting an astro-physical observatory on the heights of Arlington; its purpose being, as its name implies, the investigation of the physical constituents of the heavenly bodies.

— The bill for the establishment of a zoological park and museum stands much better in Congress than it did at the last session, and it looks at this moment as if the appropriation for the purchase of the land on Rock Creek would be granted. Professor Hornaday has made a strong impression on the committees which he has addressed, and has excited national emulation by contrasting this country with other lands in its neglect of opportunities to study its own natural history.

— The scientific bureaus of Washington are seeking more elbow-room. The ambition of the Geological Survey to have a new building (\$600,000) is matched by that of the Smithsonian, which seeks an appropriation of \$500,000 for the erection of a building in the other corner of the grounds. The plan contemplates a structure somewhat like the present, but without an interior court, and with two stories and a basement instead of one story.

— The National Museum has secured Col. James Stevenson's private collection of Indian relics, entirely Pueblo. It contains several hundred pieces, among them an example of pottery for which Tiffany recently offered \$250.

— Experiments are being made at Wheeling, W. Va., with a view to the utilization of natural gas as a fuel in the smelting of iron ore.

SCIENCE:

A WEEKLY NEWSPAPER OF ALL THE ARTS AND SCIENCES.

PUBLISHED BY

N. D. C. HODGES,

47 LAFAYETTE PLACE, NEW YORK.

[Entered at New York Post-Office as second-class mail-matter.]

SUBSCRIPTIONS.—United States and Canada..... \$3.50 a year.
Great Britain and Europe..... 4.50 a year.

Science Club-rates for the United States and Canada (in one remittance):

1 subscription 1 year \$ 3.50
" " " 1 year 6.00
2 " " 1 year 8.00
4 " " 1 year 16.00

Communications will be welcomed from any quarter. Rejected manuscripts will be returned to the authors only when the requisite amount of postage accompanies the manuscript. Whatever is intended for insertion must be authenticated by the name and address of the writer; not necessarily for publication, but as a guaranty of good faith. We do not hold ourselves responsible for any view or opinions expressed in the communications of our correspondents.

VOL. XIII. NEW YORK, JAN. 25, 1889. No. 312.

CONTENTS:

THE STORAGE OF ELECTRICITY.....	53	NOTES AND NEWS.....	61
A BLIZZARD MEETS AN ELECTRIC ROAD.....	56	EDITORIAL.....	62
TESTING A PNEUMATIC DYNAMITE GUN.....	56	Political Influence in New York Schools.....	
THE RISLEY AND LAKE COMPOSING-MACHINE.....	56	THE VALUE OF MERCURIC CHLORIDE AS A DISINFECTANT.....	62
METHYLATED ALCOHOL <i>Edgar Richards</i>	57	FIFTH ANNUAL REPORT OF THE BUREAU OF ETHNOLOGY.....	64
ELECTRICAL NEWS.		BOOK-REVIEWS.	
Dissipation of Fog by Electricity..	59	The Birds of the West Indies....	65
Trials of the Submarine Boats "Gymnote" and "Peral".....	59	Louis Lambert.....	65
New Reckenzaun Tram-Car.....	59	AMONG THE PUBLISHERS.....	65
Snow-Storms on Electric Roads....	60	LETTERS TO THE EDITOR.	
Application of Electric Motors to Mining.....	60	Dew-Point and Predictions of Weather <i>H. A. Hazen</i>	70
SCIENTIFIC NEWS IN WASHINGTON.		Horns of the Prong-Buck (Antilocapra) <i>Henry L. Ward</i>	70
Some Habits of the Omahas.....	60	Felspar, or Feldspar? <i>A. R. C. Selwyn</i>	71
Electrical Conductivity of Glass..	60	The Soaring of Birds <i>Wm. Kent</i>	71
Fish Commission Experiments....	60	The Color of Katydid <i>Jos. Story Fay</i>	71
The Woman's Anthropological Society.....	60		
The Survey for Irrigation.....	61		
Indian Relics from Florida.....	61		

WE CALLED ATTENTION last week to the condition of affairs in the New York City Board of Education, and chronicled the triumph of political chicanery over public interest in the organization of the board for the coming year. Inasmuch as this situation in New York is of the greatest importance to educational interests all over the land, we shall revert to it from time to time, and endeavor to aid in forming an intelligent and conscientious public opinion which shall eventually displace the politicians and the politics that are now controlling the schools of the metropolitan city. The next contest will be over the report of the special committee on reform in the schools, the first instalment of which is now before the board, for action at its next meeting. The report is signed by Commissioners Webb, Cole, Sprague, O'Brien, Agnew, Dodge, Galloway, and Schmitt. It limits its consideration to a single point, and that perhaps the fundamental abuse of the New York City system; namely, the examinations of the children, as made by the city superintendent and his assistants, for the purpose of marking and grading the teachers and principals in the respective classes and schools. The committee believe—and we cordially indorse that belief—that many of the existing evils in the schools are the outgrowth and natural sequence of the methods now employed in a vain attempt to ascertain the true character of classroom work. The vicious system which is now in vogue has not (happily) the

sanction of any statute; but it has been built up by the present city superintendent and his predecessors, on the meagre provisions of a single by-law of the Board of Education itself.

This is the committee's account of the system: "The city superintendent or his assistants examine, orally and in writing, the children of every class in every school at least once a year. When the examination is to be made, a notice, varying in time from one to six days, is sent to the principal and teachers. The average time that the examiners spend with each class does not exceed half an hour. The main object of the examination of the pupils is to grade and mark the teachers, and to determine with what degree of success the classroom work is carried on. Marks are given by the examiners to the teachers on each subject; but the teachers are not informed what marks are awarded, nor is any provision made by which such information may be conveyed to them. The general results are reported to the trustees of the respective wards in which the teachers are employed; but as to how such results are reached, or in what particular subject a class may have failed, the record is silent. The teachers know that these marks (if they receive any attention) will form the basis upon which promotion, or worthiness for promotion, is to be determined. They know that in case of illness, when it may be necessary to come before the board, if the marks are below a certain standard, the salary expected may be seriously diminished; and that, in case two marks of 'fair' are awarded in succession, a summons will be received to appear before a committee of the board and answer to a charge of inefficiency as a teacher. At times, to the young, nervous, or inefficient teacher, the examination is a positive bugbear, and the examiner a natural enemy; and this estimate is speedily detected and shared in by the pupils. In such a class the examiner is not looked to for help, suggestion, or instruction; but he is regarded as one from whom all faults and weaknesses must be diligently concealed, and before whom the children are to make as brilliant a show as possible. His sole purpose is to assign a mark for each study, and that mark is to go down on the official record, to aid or mar the teacher's future advancement in the system."

This is the barbarous practice by which the executive officers control the schools and intimidate the teachers. Its mere statement is sufficient indictment. What are you going to do about it? say its beneficiaries. The committee is ready with an answer. After adequate examination, divide the teachers once and for all into two grades,—maximum and standard. All teachers who have been at least five years in the system, and who satisfy the principals with whom they have served, and the city superintendent (or, if they fail to agree, the committee of the Board of Education on teachers), are to be classed as maximum grade, and relieved of future examinations by the superintendent or his assistants, unless the principal reports that such a teacher is falling off and should be subjected to inspection. All other teachers shall be classed as standard grade, and shall receive not only visits of inspection, but help, from the assistant superintendents, in order to aid them in improving their work and in passing to the higher classification. The committee elaborates this principle, and reports the necessary amendments to the by-laws of the board, to place it in operation. The recommendations should be adopted, although it is reported that the "ring" will oppose them bitterly. We shall await the vote with interest.

THE VALUE OF MERCURIC CHLORIDE AS A DISINFECTANT.

IN *Science*, xii. p. 185, we quoted at considerable length from an article by Dr. W. B. Hills of Cambridge, Mass., which first appeared in the *Boston Medical and Surgical Journal*, in which the author of the article criticised in severe terms the recommendations of the committee on disinfectants, of the American Public Health Association, with reference to the use of mercuric chloride as a

disinfectant. In commenting on this article of Dr. Hills's, we said that Dr. Hills's criticisms dealt, not with generalities, but with particular errors which he claimed the committee had made, and that his criticisms put the committee on its defence.

In an exceedingly able article published in the *Boston Medical and Surgical Journal* of Jan. 3, 1889, Professor V. C. Vaughan, of the University of Michigan, and a member of the committee on disinfectants, meets the criticisms of Dr. Hills completely, and places the report of the committee on more substantial ground than ever. This reply of Professor Vaughan's we have deemed of sufficient value to give in full.

The report of the committee of the American Public Health Association on disinfectants, together with the experimental investigation of others, has given great prominence to the employment of mercuric chloride as a germicide. Recently (*Boston Medical and Surgical Journal*, Aug. 25, 1888) Dr. William B. Hills of Cambridge, Mass., has criticised the above-mentioned report so far as it recommends mercuric chloride. As this is a matter of great practical importance, I propose in this paper to notice the points raised in this criticism. Dr. Hills does not seem to have made any biological or chemical tests himself, but founds his opinion upon what he deems to be well-established facts. The critic uses severe language with reference to the committee, and asserts that "it is not creditable" that the committee should have made the recommendations referred to upon the experimental evidence presented.

In the first place, Dr. Hills states that corrosive sublimate is rendered insoluble when brought in contact with organic matter. He says: "It is, however, a well-known chemical fact that the corrosive sublimate is destroyed, or at least undergoes chemical changes, when brought into contact with organic matter. It is immediately converted by albumen to the insoluble albuminate of mercury. For this reason, albumen is recognized as the most efficient antidote in cases of poisoning by corrosive sublimate."

Now, let us inquire into the well-known chemical fact referred to by Dr. Hills. I endeavored to show in the report, which Dr. Hills criticises, that the albuminate of mercury is soluble in solutions containing organic matter, and that it does diffuse through such solutions; but, as Dr. Hills places his opinion against my experience, we will see what others say upon this point. Merck (*Merck's Bulletin*, August, 1888) of Darmstadt says that the albuminate of mercury, which he manufactures according to the formula of Schneider (*Pharm. Centralblatt*, 1888), is readily soluble in blood-serum, meat-broth, sodium chloride, etc. Every physician knows that the albuminate of mercury is used hypodermically on account of its ready solubility and non-irritating properties. For the preparation of this compound either egg-albumen, blood-serum, or peptone is used. Merck uses egg-albumen, while Filehne (*CLOETTA'S Lehrbuch der Arzneimittellehre*, 1887, S. 134) recommends the following formula: "15 grams of dry peptones, 10 grams of bichloride of mercury, 15 grams of ammonia chloride, and enough water and glycerine so that each cubic centimetre of the solution shall contain from two to four milligrams of mercuric chloride." Other formulæ are given by other authors. In one place Dr. Hills admits that the albuminate of mercury is "slightly soluble," but he says "the amount redissolved is very small." Filehne's solution contains more than two and a half drams of the bichloride. This amount would hardly be called "very small." When Dr. Hills says that albumen is recognized as the most efficient antidote in cases of poisoning by corrosive sublimate on account of the insolubility of the albuminate of mercury, he teaches a doctrine which, I must admit, is wholly new to me. Mercuric bichloride owes its corrosive properties to the avidity with which it combines with proteids. In cases of poisoning by this salt, we give the albumen in order to supply a proteid with which the poison can combine without injury to the walls of the stomach, and then we hasten to give an emetic. What would be the result if we should leave the albuminate of mercury in the stomach? If this compound is so insoluble, why do we give the emetic? The idea that the albuminate of mercury would not be readily absorbed by the stomach, is, to use some of Dr. Hills's vigorous English, "so absurd that it would not deserve serious notice were it not for the fact" that it has been suggested by one so eminent in the profession. If mercury forms an inert compound with albumen and other proteids, how is it that

we get constitutional effects by the administration of the compounds of this base in the treatment of disease? Are the contents of the stomach and intestines always free from proteids when the medicine is administered? The truth is, that the albuminate of mercury is insoluble in water, but is freely soluble in excess of albumen, in blood-serum, in meat-broth, in solution containing sodium chloride, etc. Indeed, all the mercury given medicinally is said by leading therapeutists and physiological chemists to be converted into the albuminate before it is absorbed. Filehne says concerning the absorption of mercury: "The salts of mercury soluble in water form first with albumen compounds, which, partly in excess of albumen, partly from the action of other substances, as sodium chloride, hydrochloric acid, etc., are soluble, so that the passage of these compounds into the blood as soluble albuminates is undoubted. The compounds insoluble in water are, by the action of sodium chloride and hydrochloric acid, converted into the sublimate, and this in turn into the albuminate." Nothnagel and Rossbach (*Handbuch der Arzneimittellehre*, sechste Auflage, S. 194) say that while the albuminate of mercury is insoluble in water, it is freely soluble in excess of albumen and in sodium chloride.

Dr. Hills again says: "Sternberg, in the *Medical Record* for Aug. 1, 1885, affirms positively that the albuminate (of mercury) is a potent germicide, but gives no facts in support of this statement. Klein's experiments, however, suggest that its germicide power is very slight at the most. Admitting, however, that it has such power, the amount redissolved is very small, and this is likely to be converted at once to the inert sulphide by the sulphuretted hydrogen present."

I have italicized the assertion to which I desire to give immediate attention. Here Dr. Hills is again wrong. Sulphuretted hydrogen does not decompose the albuminate of mercury. Every toxicologist knows this, and destroys the organic matter before he attempts to precipitate mercury from solutions containing proteids. In the report of the committee, where I show that the albuminate of mercury is soluble, I state that the organic matter was destroyed by potassium chlorate and hydrochloric acid, after which the mercury was precipitated with sulphuretted hydrogen. Nothnagel and Rossbach (*loco citato*) say that "from the albuminate of mercury one cannot precipitate the metal with sulphuretted hydrogen until the organic matter has been destroyed." If sulphuretted hydrogen precipitates mercury from proteid solutions, the mercury so precipitated is not combined with albumen, and the occurrence of such a precipitation shows that the mercury exists in excess above that taken up in the formation of the albuminate. The albuminate of mercury is not easily decomposed.

Again: Dr. Hills thinks that the alkalis formed in decomposing matter would precipitate the mercury. Nothnagel and Rossbach (*loco citato*) say that "if common salt be added to an alkaline solution of albumen, mercuric chloride will then fail to produce any precipitate." No one will question the existence of common salt in privy-vaults.

It is true that Klein's experiments suggest that the germicide power of mercuric albuminate is very slight at most. Indeed, Klein asserts (or rather did assert) that a one-per-cent solution of mercuric chloride is no more a germicide than is vinegar. Certainly no one will now champion this statement, although vinegar is not worthless as a germicide. Koch found that the spores of the anthrax bacillus will not germinate in a proteid solution if there be present one part of corrosive sublimate in three hundred thousand. And yet Dr. Hills, without having made an experiment, condemns the committee for recommending a solution of corrosive sublimate, one to five hundred, for the disinfection of the liquid discharges of cholera, typhoid-fever, etc.

Dr. Hills finds very strong language of condemnation for the report of the committee in recommending that the amount of bichloride found necessary to sterilize broken-down beef-tea be multiplied by two, and used for the disinfection of the liquid discharges from the bowels of patients with cholera, typhoid-fever, advanced tuberculosis, septic diarrhoea, etc. As he bases his condemnation upon the incompatibility (?) of mercuric chloride with albumen, he must suppose that these stools contain a large amount of soluble proteids. In this he is again wrong: such discharges do not contain large amounts of albumen or other soluble proteids.

Simon (BECQUEREL and RODIER'S *Pathological Chemistry*, p. 459) obtained the following results from the analysis of the fecal matters in cholera:—

Water	980.00
Solid matters.....	20.00
Fat.....	0.08
Extractive matter.....	4-80
Albumen and mucus.....	0.52
Chloride of sodium, lactate and acetate of sodium, and alkaline phosphates.....	13.40
Phosphate of lime and magnesia	0.60

The blood contains, according to Hammerston, from 2,677 per cent (horse) to 4,436 per cent (rabbit) of serum albumen; and yet, according to Von Ermengen, mercuric chloride in solution of 1 : 800 and 1 : 1,000 sterilizes blood. With these figures before us, can we say that "it is not creditable to a committee of the leading sanitary association of this country" to recommend a solution of mercuric chloride 1 : 500 for the disinfection of cholera stools?

Practically we know that mercuric chloride does efficiently disinfect substances containing a hundred times as much proteid as cholera stools contain. This is done many times every day in bacteriological laboratories. Gelatine plates and tubes, agar tubes, and blood-serum tubes, laden with all the known germs, are disinfected with a solution of mercuric chloride 1 : 1,000. In Koch's laboratory this is the only disinfectant used, and there has been no evidence of its failure. Plates-covered with colonies of the anthrax bacillus, the comma bacillus, etc., are immersed in the solution with the certainty that the sterilization will be complete. Old tube cultures are treated in the same way, and with the same result, whether they contain gelatine, agar, or blood-serum. Now, in the gelatine, one litre of beef-tongue contains 100 grams of gelatine, 10 grams of peptone, and 5 grams of sodium chloride. We have seen that the albuminate of mercury is made with peptone as well as with albumen, and there is nearly twenty times as much peptone in this mixture as there is albumen in cholera stools, and nearly two hundred times as much gelatine besides. Certainly no one will question the large amount of albumen in blood-serum. Is it not strange, if the albuminate of mercury is so "inert," that the disinfection of these cultures should be so successful? Even the evacuations of infants with green diarrhoea, containing a large amount of undigested food, do not contain as much proteids as do gelatine cultures, as is shown by the following analysis of Golding Bird:—

Water.....	900.00
Biliverdin, alcoholic extracts, fat, cholesterine.....	24.50
Ptyalin, watery extract, colored with biliverdin.....	11.25
Mucus, coagulated albumen, and hematin.....	56.00
Chloride of sodium, with traces of tribasic phosphate of soda.....	5.50
Tribasic phosphate of soda.....	1.75
Peroxide of iron.....	1.00

In the first report of the committee (1885) a solution of chloride of lime was given the first place for the disinfection of excreta in the sick-room, and a solution of mercuric chloride of the strength of 1 : 500 the second place. In the latest report (1888) carbolic acid has been given the second place, and mercuric chloride has not been recommended for this purpose. This change was made because the carbolic acid was believed to be sufficient, and not because the mercuric chloride was believed to be inefficient. In the light of the most recent experiments in this country and abroad, we believe that mercuric chloride, in the proportion named, would be effective in the disinfection of the liquid discharges of patients suffering from typhoid-fever or cholera, and that the recommendation made in our first report was justified by the experimental data then given, and not yet contradicted by any new evidence.

The committee called attention to the action of mercuric chloride on lead pipes in its first report, and this influenced it in substituting carbolic acid for mercuric chloride for disinfecting the excreta in the sick-room.

To return to our critic, the broad statement is made, that "an examination of the report of this committee fails, however, to bring to light the slightest particle of evidence upon which such a recommendation could have been based;" viz., the disinfection of excreta with mercuric chloride. Dr. Sternberg, chairman of the committee, made extended researches upon the germicide power of this agent several years before (1883) the committee was appointed, and to those experiments reference is made in the first report. It is for

this reason that extended experimental researches were not made with this agent in 1885. However, a number of experiments were made, and recorded in our report. These show that even the solid or semi-fluid feces of a healthy person may be sterilized by the use of the solution recommended by the committee, provided that they are broken up so as to be fairly exposed to the action of the disinfecting agent. Moreover, the fact is recorded that a certain amount of the mercurial salt remained in solution at the end of twenty-four hours, as shown by a deposit of mercury on a copper wire (experiment of Sept. 8). Yet our critic, without recording a single experimental observation of his own, states that there is not the slightest particle of evidence upon which our recommendation could have been based.

One who has given no special attention to chemistry may be pardoned for not being acquainted with the chemical nature of the albuminate of mercury, but certainly any one who had read our report could not have made the sweeping assertion which we find in Dr. Hill's criticism.

FIFTH ANNUAL REPORT OF THE BUREAU OF ETHNOLOGY.

THE "Report of the Director of the Bureau of Ethnology for the Year 1883-84" has just been issued, bearing the date 1887. The long delay of this report, which is caused by the pressure of work in the Government Printing-Office, must be greatly regretted, as the interest of science demands that scientific publications of the character of those accompanying the report be known as early as possible. The knowledge that certain statements and opinions are about to be published always acts as a drawback upon the progress of the special field of science, as most workers will delay further investigations until these publications are issued. While a few branches of science may not be very adversely affected by these delays, such is not the case in the science of anthropology, in which the most energetic and unceasing field-work is absolutely necessary, as the relics of ancient times, as the natives and their customs, are vanishing with steadily increasing rapidity. Publications of such importance as the one under discussion always prove an incentive to increased activity. The opinions and suggestions expressed in the papers accompanying the report do not fail to influence the progress of investigations. For all these reasons a more rapid publication of the annual reports is very desirable.

Major Powell, in the first part of the report, gives a brief review of the work carried on by the bureau. The scope of the researches is constantly increasing. In the year 1883-84 the mound-explorations were continued. Messrs. Stevenson and Mindeleff carried on archaeological researches in the South-west, while Mr. Frank Cushing devoted himself to further studies on the Zuñi. Linguistic work was done among the Iroquois, in California, and among the Navajo. While the final results of the works of the bureau will be published as "Contributions to the Ethnology of the North American Indians," the papers accompanying the reports generally treat certain phenomena of Indian life or art in the form of monographs or reports on peoples on which no material for exhaustive reports is obtainable.

Of the latter class, we notice in the present volume Rev. Clay MacCauley's description of the Seminole Indians of Florida,—an interesting sketch of the life and state of this small tribe living in the most inaccessible portion of the southern half of the peninsula.

The elaborate paper on "The Cherokee Nation of Indians: A Narrative of their Official Relations with the Colonial and Federal Governments," by Charles C. Royce, is an historical document of the greatest importance, the history of this great confederacy in its conflicts with the white settlers encroaching upon their territory being traced fully and exhaustively. The paper is an illustration of a work of wide scope undertaken by the bureau,—an historical atlas of Indian affairs, showing, upon a series of State and territorial maps, the boundaries of the various tracts of country which have from time to time been acquired through the medium of treaty stipulations or act of Congress from the several Indian tribes resident within the present territory of the United States. Accompanying the atlas will be one or more volumes of historical text, wherein will be given with some detail a history of the official

relations between the United States and these tribes. This will treat of the various negotiations for peace and for the acquisition of territory, the causes rendering such negotiations necessary, and the methods observed by the government through its authorized agents in this diplomacy, as well as other matters of public concern growing out of the same. The eminent value of this work to the historian is self-evident, and the laborious care bestowed by Mr. Royce upon the carrying-out of this plan promises that it will be at once an exhaustive and clear treatment of this important part of the history of our Republic.

The first paper of the volume is Professor Cyrus Thomas's treatise on "Burial-Mounds of the Northern Section of the United States." Since this paper was written, much evidence has accumulated which has been outlined in a bulletin of the Bureau of Ethnology. It corroborates the views expressed by Professor Thomas in the present report.

His conclusions, as set forth in this paper, are that different sections of the country were occupied by different mound-building tribes, which, though belonging to much the same stage in the scale of culture, differed in most instances in habits and customs to a sufficient extent to mark, by their modes of burial, construction of their mounds, and their works of art, the boundaries of the respective areas occupied. He furthermore concludes that each tribe adopted several different modes of burial, depending, in all probability, to some extent upon the social condition, position, and occupation of the deceased. The custom of removing the flesh before the final burial apparently prevailed very extensively among the mound-builders of the northern sections; the bones of the common people being often gathered together, and cast in promiscuous heaps, over which mounds were built. Usually some kind of religious ceremony was performed at the burial, in which fire played a prominent part; but, notwithstanding the very common belief, there is no evidence whatever that human sacrifice was practised. The builders of the mounds had not reached a higher culture than that attained by some of the Indian tribes found occupying the country at the time of the first arrival of Europeans. Professor Thomas concludes his treatise by expressing his opinion that the mound-building age cannot have lasted longer than about a thousand years, and that it continued to be practised in several localities in post-Columbian times.

There remain two papers to be noted, both of peculiar interest, — the one by Dr. Washington Matthews, who gives a very detailed description of one of the remarkable religious ceremonies of the Navajo; the other by Mrs. T. E. Stevenson on the religious child-life of the Zuñi.

Dr. Matthews describes the long ceremonies of the Mountain-Chant, and gives the long myth which is the foundation of these ceremonies. His paper concludes with the original texts of the songs, and translations of the same. It is impossible to give an account of the interesting contents of this essay, which is full of new facts of the greatest importance to the student of anthropology.

Mrs. Stevenson's paper is of a somewhat similar character, treating of the connection between certain customs and myths. This field of study, so ably taken up by Dr. Matthews and Mrs. Stevenson, has so far received comparatively little attention; and yet it is one of the most important for the study of the human mind and of the growth of institutions.

The publications of the Bureau of Ethnology mark every one a long step forward in our knowledge of man in America, and are therefore anxiously awaited by all students. We hope that the following volumes may be issued at shorter intervals, that the important material contained in them may soon become public property.

BOOK-REVIEWS.

The Birds of the West Indies. By CHARLES B. CORY. Boston, Estes & Lauriat. 8°.

IN preparing the present work, Mr. Cory examined a large series of birds from nearly all the islands of the West Indies, the combined collections representing many thousands of specimens. He made five trips to different parts of these islands, besides which a

number of collectors were sent out, for the purpose of obtaining as complete a series as possible. Several of these collectors were engaged upon their task from six to eighteen months, and it is fair to assume that their collections contained nearly all of the resident species of the islands which they visited. Some of these collections proved especially interesting, being very rich in novelties, the collections of one person containing no less than seventeen species new to science.

Most of the matter contained in the present work appeared originally in the *Auk* during the years 1886, 1887, and 1888; but since that time a large number of species have been added to the West Indian avifauna which were either new to science or had not been previously recorded from that locality. Descriptions of these are given in an appendix, unless included in their proper order in the body of the work. A number of alterations and corrections have been made in the original plates, and several new illustrations have been added. No descriptions are given of well-known North American birds, and the references to such are mainly restricted to the citation of works and papers on West Indian ornithology.

The excellent mechanical make-up of the book admirably supplements the painstaking and thorough work done by Mr. Cory in its preparation.

Louis Lambert. By HONORÉ DE BALZAC. Tr. by Katherine P. Wormeley, with introduction by George F. Parsons. Boston, Roberts Bros. 12°. \$1.50.

BALZAC seems to have written this story for the express purpose of making known what he would call his philosophy, which is a curious compound of mysticism and nonsense. The hero of the tale, Lambert, is introduced when a boy, and considerable space is given to his experience and reflections while at school. At a later time, after a season in Paris, he falls in love with a titled lady, and marries her. Unfortunately, however, he becomes insane just before his marriage, and remains so ever after, and dies while still a young man. The "philosophy" of the book is contained partly in his conversations and letters, but chiefly in some papers composed after he became insane; and these latter seem to be the dearest to the soul of Balzac. The doctrine expressed in them is of the occult kind, as will be seen from the following specimens: "Here below all is the product of an ethereal substance, the common base of several phenomena. . . . Will is a fluid, the attribute of every being endowed with motion. . . . Facts are nought; they do not exist; ideas alone exist. . . . All things here below exist only by motion and by number. . . . There is a number which impurity cannot transcend — the number wherein creation is finished. . . . Three and seven are the two great spiritual numbers" (pp. 138-148). Besides the story that gives name to the book, there are two others in the volume; but there is little connection between them and Louis Lambert; and the second of them, Gambara, we have found intensely disagreeable. The introduction to the book, which is as long as the leading story, is partly a summary of Balzac's ideas, and partly an attempt to reconcile them with the teachings of physical science, — an attempt which, as may be supposed, is not very successful.

AMONG THE PUBLISHERS.

GINN & Co. announce "An Introduction to the Poetry of Robert Browning," by William John Alexander, Munro professor of English language and literature, Dalhousie College and University, Halifax, N. S., and formerly fellow of Johns Hopkins University, to be published in February. The book opens with an account of Browning's most striking peculiarities in method and style, and attempts to find an explanation of these in the conditions amidst which the poet has worked, and in the nature of the themes which he treats. In the next place, an exposition is given of those general ideas pervading his work, which can only be gathered from the study of many of his poems, and yet are needful for the full understanding of almost any one of them. This exposition is contained in a series of chapters on "Browning's Philosophy," "Christianity as presented in Browning's Works," and "Browning's Theory of Art." These chapters are followed by a brief chronological review of his writings, and characterization of his development. The various points treated throughout the introduction are illustrated

by a series of selected poems furnished with careful analyses and copious critical comments. It is hoped that by thus unfolding, in a few typical examples, the characteristics and merits of Browning, the reader may at once be enabled to acquire a real knowledge of his poetry, and be prepared for further unassisted study of his work. The attention of those already familiar with Browning is especially directed to the analysis of "Sordello," much fuller and more exact, it is believed, than any heretofore published.

—The *Revue Philosophique de la France et de l'étranger*, edited by Th. Ribot, professor at the Collège de France, has just commenced its fourteenth year. This periodical is published monthly, each number containing about one hundred pages. Special attention is paid to psychology and its indispensable auxiliaries, anatomy and physiology of the nervous system, pathology of the mind, anthropology, and inductive and deductive logic. Reports on the current philosophic literature enhance the value of the journal.

—The *Revue Historique* for 1889 continues to be of great interest. It is published bi-monthly, and, besides original contributions, each number contains notes of general interest, unpublished documents, and a useful bibliography. It is published by F. Alcan, Paris.

—Neumayr, the distinguished paleontologist of Vienna, has just published through Tempky a first stout imperial octavo volume of a work upon which he has been engaged for many years, in which he is to review the entire series of extinct animals in the light of the derivative theory of organic life. Under the title "Die Stämme des Thierreiches" he discusses the lower forms of life, leaving the mollusks, arthropods, and vertebrates for future volumes. The purely theoretical side of the subject and the purpose, with which he began his studies, to search in every quarter for proofs of the alteration of forms, have gradually, in working out his scheme, given place to a critical and scholarly investigation into the general morphology of fossil animals; and his work will thus prove of the utmost value not to the paleontologist only, but equally to the zoologist. No living naturalist is more competent than he to perform the task. In an introduction of over 150 pages he discusses the general questions of the relations of the derivative theory to paleontology in a masterly manner; subsequent chapters take up successively the protozoa, coelenterates, echinoderms, worms, and molluscs. The second volume, treating presumably of the remaining invertebrates, is, he tells us, nearly completed. The work forms an excellent complement to Zittel's nearly completed "Handbook of Paleontology."

—The *American Naturalist* for January (New York, Leonard Scott Publishing Company) will contain an article on "Primitive Architecture," by Mr. Barr Ferree, in which is traced the various sociological causes that have influenced the form and construction of the dwellings of primitive peoples. The same number will contain an article on "The Food of the Owls," by Dr. W. S. Stodge; on "The Ancient Glaciers of North Wales," by Professor Evans; and on "Lichens," by Professor Williams. The departments of the magazine will present their usual summary of the progress of all branches of natural science within the past month.

—A remarkably successful attempt at photographing the very shy Big-horn, or Rocky Mountain sheep, will be described in the February *Scribner* by Frederick H. Chapin, who succeeded in taking a group on Table Mountain, Colorado, in 1887. The photograph has been engraved to accompany the article. In the same number Austin Dobson will recall some memories of "Old Vauxhall Gardens" in its prime,—the days of Walpole, Fanny Burney's "Evelina," and Fielding's "Amelia." The article will be fully illustrated from old prints. In his article on Sir Walter Scott, Ex-President Andrew D. White of Cornell will say of him, "Never was there a more healthful and health-ministering literature than that which he gave to the world. To go back to it from Flaubert and Daudet and Tolstoi is like listening to the song of the lark after the shrieking passion of the midnight pianoforte; nay, it is like coming out of the glare and heat and reeking vapor of a palace ball into a grove in the first light and music and breezes of the morning." George Hitchcock, the artist whose contribution to

Scribner's Christmas number on "Botticelli" will be recalled, will appear in the February number, with a second article on "The Picturesque Quality of Holland," this time describing "Interiors and Bric-a-brac." Mr. Hitchcock has for many years lived in Holland. The February instalment of Robert Louis Stevenson's romantic novel, "The Master of Ballantrae," will describe the pathetic persecutions of, "Mr. Henry," and the unexpected return of the "Master." Brander Matthews will have in the number an ingenious and fanciful story, entitled "A Family Tree."

—Charles A. Wenborne, Buffalo, N.Y., announces for immediate publication an "authorized" American edition of Laurence Oliphant's "Scientific Religion; or, Higher Possibilities of Life and Practice." This book, when first published in London eight months ago, immediately became a subject of such wide-spread interest that the author felt impelled to arrange, also, so says Mr. Wenborne, "for its publication in the United States. He visited this country last summer, and upon his return to England was taken down with the fatal illness that terminated his eventful life on Dec. 23. The author's intention to give a distinct introduction to the American edition was carried out by his newly wedded wife, an American lady, born Dale Owen, who had for some time been a distinguished co-worker in that field of religio-philosophical science of which Laurence Oliphant may be regarded as the most brilliant, most profound, and most advanced explorer of modern times."

—*The Green Bag*, "a useless but mildly entertaining magazine for lawyers," to be edited by Horace W. Fuller, is announced by Charles C. Soule, Boston. It is to be a monthly, intended to interest and entertain lawyers. It will cover legal history, antiquities, biography, news, gossip, and facetia, together with correspondence and book notices. The first number, to be published this month, will contain an excellent portrait of Chief Justice Fuller in his robes of office. Each subsequent number will contain the portrait of some distinguished judge or lawyer. There will also be illustrated articles, among them a series of papers upon the leading American law schools.

—We have received two pamphlets by Charles H. Fitch of Denver, Col., on "Womanhood Suffrage" and on "The Fallacy of Free Land" (published by the author), but we find nothing new or valuable in either of them. The first presents the usual arguments in favor of woman suffrage, but in an obscure and rather grandiloquent style. The second is an argument for the Henry George theory of rent, and the injustice of private property in land, but contains nothing that has not been repeatedly said by others. The subjects treated, like some other political and economic questions of the present time, have been discussed so much, that unless one can say something new on them, or can present the old arguments in a superior form, there seems to be no good reason for his treating them at all.

—One of the best known of the English journalists in America to-day is Mr. W. T. Stead, the managing editor of the *Pall Mall Gazette*. As a journalistic worker, Mr. Stead has seldom had an equal; and recently, when offered a vacation, he took it on the condition that he might work. The vacation became a trip to Russia, the result of which is to be published in a stout volume by Cassell & Co. While the political situation is the burning question of the book, he has time to visit Count Tolstoi, and to give the reader pictures of Russian life painted with a realism that M. Verestchagin might envy.

—The *American Anthropologist* for the first quarter of 1889 comes to us in a handsome brown cover and a generally improved typography and appearance. It contains Washington Matthews's article on the curious "Navajo Gambling Songs," and especially the melodies which accompany the winter game of Kesticé; Otis T. Mason's examination of the beginnings of the carrying industry, an illustrated article; "On Alternating Sounds," by Franz Boas; "Folk-Lore of the Siletz Indians," by J. Owen Dorsey; a summary of current methods of voting, by James H. Blodgett; and a variety of original notes and news. The feature of this quarterly which will excite most attention is the first instalment of a bibliography of anthropological literature, by Robert Fletcher, who has undertaken the

valuable service of preparing a similar compilation for each number.

— So strong a feeling has been manifested in this country against the publication of a cheap pirated edition of Professor Bryce's noble work on "The American Commonwealth," says the *New York Tribune*, that it is hardly possible that any publisher will undertake it. The *Boston Advertiser* says, "Professor Bryce's materials were gathered by the most patient, candid, and acute inquiry in this country, and represent many years of labor on his part and that of his American assistants. He has made admirable use of them in the preparation of a work universally recognized as a monument to our Commonwealth, and of the foremost importance to all students of our institutions and people. For such a monograph the nation cannot afford to show itself ungrateful. If a publisher attempts to put an edition of this work on the market to defraud the author and discredit the nation, his attempt should be pilloried as peculiarly disgraceful, and the edition should be boycotted by honest book-buyers."

— E. Hollenshade, 136 Lake Street, Chicago, has published what he calls a "gored map" of the northern and southern hemispheres, which is a novelty well worthy the attention of educators and students. It is designed to obviate the necessity of a globe in the study of geography, and conveys an adequate conception of the exact relations borne by one portion of the earth's surface to every other.

— Messrs. Longmans & Co. are about to publish in New York two new books of fiction. One is "A Nine Men's Morrice, Stories Collected and Recollected," by Mr. Walter Herries Pollock, the editor of the *Saturday Review*. Most of these striking stories have a tinge of the supernatural. The other book is "A Dangerous Cat's-paw," by D. Christie Murray, and his brother Mr. Henry Murray. This is at once a story of ingenuity and mystery, with the robust humanity common to Mr. Murray's other novels.

— "Chancellor Chess, or The New Game of Chess," by Ben. R. Foster, A.M., chess editor of the *St. Louis Globe Democrat* for more than ten years, is announced as in press. Seventy pages are devoted to the new piece called "The Chancellor," containing a history of its origin, "with forty problems, and a number of games illustrative of its beauties, powers, and possibilities." It is published by the author, in St. Louis, Mo.

— Charles Scribner's Sons published last week "The History of the Roman Republic," abridged from the history of Professor Mommsen, by C. Bryans and F. J. R. Henty, which presents the salient points of the original in a form suitable for use in schools and colleges and for the convenience of the general reader; "The English Restoration and Louis XIV., from the Peace of Westphalia to the Peace of Nimwegen," by Osmund Airy, in the Epochs of Modern History Series; and "The Validity of Non-Episcopal Ordination," the Dudleian lecture, by Professor G. P. Fisher.

— Scribner & Welford have just issued a new edition of Barry E. O'Meara's "Napoleon at St. Helena," in two volumes, with numerous illustrations in colors and black and white. A refutation of Croker's diatribe which appeared in 1822, and a Napoleon calendar, have been added by the editors. They have also just ready a new edition of D'Anvers' "History of Art;" a new edition, in the Ideal Series, of "Sartor Resartus," with an etched portrait of Carlyle; an *édition de luxe* of "Kensington, Picturesque and Historical," by W. J. Loftie, with upwards of 300 picturesque and delicate illustrations by W. Luker, jun.; and the first volume of Professor Franz Delitzsch's "Commentary on the Book of Genesis," of which this house (by special arrangement of the author) is publishing a translation of the fifth edition, thoroughly revised, and in large part rewritten.

— According to *The Publishers' Weekly*, the new departure of the *New York Ledger* attracts much notice. Mrs. Burnett and Mr. Stevenson are engaged to write for the *Ledger*, and in the current number a learned paper by Dr. McCosh is found beside some very lurid fiction.

— *The American* states that Collier's *Once a Week* is a sort of eagle among the doves. It is said to offer "rates" to the most

popular writers, such as the magazines, with all the pressure of competition, decline to pay, and to threaten a consequent monopoly of much of the high-priced talent. Its liberality confounds the older journals.

— Mr. Thomas Stevens, whose ride around the world on a bicycle is known to all, is now on his way to find Stanley, sent through the enterprise of the *New York World*. We reproduce this week his portrait. Mr. Stevens's famous ride stands unequalled in the history of travel, and his own story of it, in "Around the

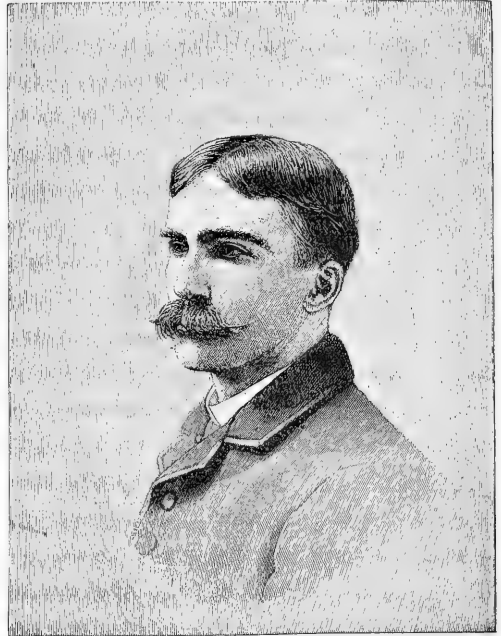

Yours sincerely
 Thos Stevens

World on a Bicycle" (published by Charles Scribner's Sons) is told in a manner which charms the reader from the beginning. His escapes from death were marvellous, and thrilling incidents were daily occurrences; and his narrative of them shows him to be as good a writer as wheelman. The work contains over 200 illustrations. The work is divided into two volumes,—"From San Francisco to Teheran," and "From Teheran to Yokohama." The volumes are, however, sold singly.

— From among the several hundred books published during 1888 by J. B. Lippincott Company, we note the following as likely to be of special interest to our readers, aside from works of fiction: "The Animal Life of Our Sea-Shore," by Angelo Heilprin (fully illustrated); "Beethoven," a memoir, by Elliott Graeme, with an introductory essay by Dr. Ferdinand Hiller; "Béranger's Songs and Poems," selected by W. S. Walsh (with steel plate illustrations); "Botany," for academies and colleges, by Annie Chambers-Ketchum (250 illustrations); "Boys' Own Book of In-door Games and Recreations," edited by G. A. Hutchison (over 700 illustrations); "Chambers's Encyclopædia," Vols. I. and II., edited and published under

the auspices of W. and R. Chambers, Edinburgh, and J. B. Lippincott Company, Philadelphia, entirely revised and rewritten, complete in ten volumes, to be issued at intervals; "The Chemical Analysis of Iron," by Andrew Alexander Blair (illustrated); "The Complete Works in Verse and Prose of Percy Bysshe Shelley," edited, prefaced, and annotated by Richard Herne Shepperd, each volume complete in itself, in sets of five volumes; "Diseases of the Skin," a manual for practitioners and students, by W. Allan Jamieson, M.D. (illustrated with woodcuts and colored plates); "Embroidery and Lace," by Ernest Lefévre, translated from the French (with about 150 illustrations); "Francis Bacon, his Life and Philosophy," by John Nichol; "Girls' Own In-door Book," edited by Charles Peters (over 150 illustrations); "Half-Hours with the Best Foreign Authors," translations selected and arranged by Charles Morris, four volumes; "Hand-Book of Games," new edition, comprising whist, draughts, billiards, etc., edited by Henry G. Bohn; "Highways and Horses," by Athol Maudslay (with numerous illustrations); "Inebriety: its Causes, its Results, its Remedy," by Franklin D. Clum, M.D.; "Insects Injurious to Fruits," by William Saunders; in the International Statesmen Series, edited by Lloyd C. Sanders, "Lord Beaconsfield" (by T. E. Kebbel), "Viscount Palmerston" (by Lloyd C. Sanders), "Prince Metternich" (by Col. G. B. Malleson, C.S.I.), "O'Connell" (by J. A. Hamilton, fellow of Magdalen College, Oxford), "Lord Bolingbroke" (by Arthur Hassall), and "Peel" (by F. C. Montague); "Intracranial Tumors," by Byron Bramwell, M.D. (116 illustrations); "Jesus in Modern Life," by Algernon Sydney Logan; "Laconisms, the Wisdom of Many in the Words of One," by J. M. P. Otts, D.D.; "Large Fortunes; or, Christianity and the Labor Problem," by Charles Richardson; "Life of Lamartine," by Lady Margaret Domville (with portrait); "The Life of the Right Hon. W. E. Forster," by T. Wemyss Reid, two volumes (with portraits and other illustrations); "Memoirs of Count Grammont," by Anthony Hamilton, edited with notes by Sir Walter Scott (with portrait of author, and 33 etchings by L. Boisson, on India paper); "Modern Science and Modern Thought," by S. Laing (fifth edition); "Paradoxes of a Philistine," by William S. Walsh; "Patriotic Reader," by Henry B. Carrington; "A Popular History of Music, Musical Instruments, Ballet, and Opera, from St. Ambrose to Mozart," by James E. Matthew (150 illustrations); "Spinoza," by John Caird, principal of Glasgow University (with portrait); "Tenure and Toil; or, Rights and Wrongs of Property and Labor," by John Gibbons; "Therapeutics: its Principles and Practice," by H. C. Wood, M.D. (new seventh edition); "A Treatise on Mine-Surveying, for the Use of Managers of Mines and Collieries," by Bennett H. Brough (with numerous illustrations); "Two Centuries of Irish History, 1691-1870," with introduction by James Bryce, M.P.; "United States Dispensary," new sixteenth edition, by H. C. Wood, M.D., Joseph P. Remington, and Samuel P. Sadtler; "Untrodden Paths in Roumania," by Mrs. Walker (with 78 illustrations); "Walks in Palestine," the letterpress by H. A. Harper (illustrated by 24 photogravures from photographs taken by C. V. Shadbolt, Esq.); "With the Camel Corps up the Nile," by Count Gleichen, nephew of Queen Victoria (with numerous illustrations); " Worcester's New Academic Dictionary," entirely new edition, the etymology of words a distinctive new feature, reset from new type, and printed from new plates; " Worcester's New Comprehensive Dictionary," entirely new edition, containing over 48,000 words in common use, with an appendix of 15,000 proper names, new illustrations, reset from new type, and printed from entirely new plates; and "The Writer's Hand-book, a Guide to the Art of Composition," forming a new volume of the Reader's Reference Library.

— Houghton, Mifflin, & Co. will shortly publish a volume of the late Asa Gray's reviews of botanical literature during the past fifty years, selected and edited by Professor C. S. Sargent.

— F. W. Christern, New York, will be the American agent of Santa-Anna Néry's elaborate work on Brazilian folk-lore, recently published in Paris. The book has a preface written by Prince Roland Bonaparte.

— *The Chautauquan* for February contains, among other things, "Gossip about Greece," by J. P. Mahaffy of Dublin University; "Socrates," by Thomas D. Seymour of Yale University; "Greek

Art," by Clarence Cook; "Music among Animals," by the Rev. J. G. Wood; "Taxation," by Professor Richard T. Ely of Johns Hopkins University; "Hospitals," by Susan Hayes Ward; "The Power-Loom," by Charles Carleton Coffin; "A Summer Meeting in Oxford," by Herbert B. Adams; "The City of the Sultan," by Eugene L. Didier; "The Modern Migration of Nations," by Hjalmar Hjorth Boyesen; "Petroleum in Russia," by P. de Tschihatchef; "The Carlisle Indian School," by Frances E. Willard; "Robert Elsmere: An Open Letter from the Rev. Lyman Abbott;" "The Sons of Eminent Men in Office," by Mrs. Carl Barus.

— A prospectus of a monthly magazine to be called *Poet-Lore*, and to be devoted solely to the illustration of Shakspeare and Browning, and to the comparative study of poetic literature, has just been issued. It is signed by Charlotte Porter, late editor of *Shakspeariana* (from August, 1886, to December, 1888), and Helen A. Clarke, whose address is 223 S. 38th Street, Philadelphia. Dr. W. J. Rolfe will contribute to its study department a series of questions and helps for the study of Shakspeare's plays, beginning in the February number with "Love's Labor's Lost," and continuing with later plays. The "Explanatory Index to Allusions in Browning's Pauline," given in the January number, will be continued through the later poems. Dr. Horace Howard Furness' lectures on Shakspeare, delivered at the University of Pennsylvania, will appear in extracts made by Dr. Furness for this publication. W. H. Wyman's "Bacon-Shakspeare Bibliography" will be continued from the December number of *Shakspeariana*. "Browning's Poetic Form," a seminar (Johns Hopkins) lecture, by Professor A. H. Smyth; "Shakspeare's Verses in Chester's Love's Martyr," by Professor William T. Harris of the Concord School of Philosophy; "French and English Literature of Elizabeth's Day," by Professor M. W. Easton; and other contributions by Professor Hiram Corson of the Cornell University, Dr. H. L. Wayland, Michel N. Damiralis of Athens, Talcott Williams, and others, — are promised.

— D. C. Heath & Co. will put on the market shortly a series of games and charts for home and school use, based on the most approved principles of kindergarten training, prepared by Mme. Warwedel, the distinguished kindergartner of San Francisco, formerly of Washington. They have also nearly ready Scott's "Lay of the Last Minstrel," edited and annotated by T. E. Wetherell.

— G. P. Putnam's Sons will publish at once "The Pocket Gazetteer of the World," a dictionary of general geography, edited by J. G. Bartholomew, uniform with the "Pocket Atlas;" "The Nursery Lesson-Book," a guide for mothers in teaching young children, with illustrations in outline and a selection of songs set to music, by Philip G. Hubert, jun.; "Principles of Procedure in Deliberative Bodies," by George Glover Crocker; and three volumes of poetry, — "The Rose of Flame, and other Poems," by A. R. Aldrich; "Idyls of the Golden Shore," by H. Maxwell; "Mastor, a Drama," by John Ruse Larus.

— Charles C. Soule has just published a volume entitled "The Australian Ballot System, as embodied in the Legislation of Australia, Europe, and the United States," — a compilation of the ballot acts of South Australia, Queensland, Great Britain, Belgium, Kentucky, New York, and Massachusetts, with portions of the same of Tasmania, New Zealand, West Australia, Victoria, New South Wales, Dominion of Canada, Ontario, Quebec, Luxemborg, Italy, and other countries, with an historical introduction and cuts and diagrams.

— A prize of fifty dollars is offered by *The Academy* for the best essay on "English in Secondary Schools." The increased prominence of English in school programmes, and the lack of any generally accepted plan or system of work, have prompted the editor of *The Academy* to offer this special inducement to those who have devoted thought to the teaching of English, and who have definite ideas of the method of such teaching. The essays may be upon the teaching of English literature, methods of grammatical study, composition work or rhetoric, etc., but no weight will be attached to arguments in favor of teaching English. Contestants must confine themselves simply to practical exposition of results sought, and of the means of attaining these results in the schoolroom. While

literary merit will not be disregarded, the decision of the judges will rest mainly on the practical help afforded to teachers by the article. The competition is open to all persons, without regard to age, sex, color, or previous condition of servitude. The following are the conditions: No paper is to exceed in length 5,000 words; the paper awarded first prize by the committee shall become the property of *The Academy*; any papers of special merit, which may receive honorable mention, shall also become the property of *The Academy*; papers must be legibly written, so as to be published without copying, must be signed with a fictitious name (the real one being enclosed in a sealed envelope), and must be received at the office of *The Academy* on or before April 15, 1889. Manuscripts not receiving prize or honorable mention will be returned if stamps are enclosed. The names of the committee of award will be published. If further information is desired, address *The Academy*, Syracuse, N. Y.

— Dr. J. M. Toner of Washington has just brought out, in a handsome brochure, "Washington's Rules of Civility and Decent Behavior," found among the early writings of the first President, and now published in full, from the original text. They make thirty-four pages, and are believed by Dr. Toner to be an original compilation made when the compiler was only thirteen years old.

— Messrs. Belford, Clarke, & Co. will remove to new quarters Nos. 18-22 E. 18th Street, New York, about the 1st of February.

— We have received the third volume of the "Transactions and Proceedings of the Modern Language Association of America," being an account of the meeting held in Philadelphia in December, 1887, with the papers there read. The different essays, fifteen in number, are on a great variety of topics, but we can only notice a few of them. Some, indeed, are so technical that but few persons can enjoy or even understand them; while one or two were read only in part, and some that were read are not yet published. Of those before us, one of the most generally interesting is the opening one, by Mr. James MacAlister, on "The Study of Modern Literature in the Education of our Time." The author takes extreme ground in favor of modern literature as against the ancient, holding that "the literatures of the modern world are entitled to the first place in the intellectual culture of our time, and should therefore be made the chief instruments of literary training in the schools." Of course, the general sentiment of the meeting was with him in this opinion; but lovers of the classics will perhaps think that the question cannot be so summarily disposed of. Another paper of general interest is that of Professor Kroeh, on "Methods of Teaching Foreign Languages." The author reviews the various methods that have been employed, and pronounces in favor of the "natural" or conversational method; but, in the course of the discussion that followed, Professor Leidensticker suggested, that, though the "natural" method was best for giving a speaking knowledge of a foreign tongue, the grammar and reading were better for imparting a reading knowledge of it. Other papers read were on "The Style of Anglo-Saxon Poetry," on "Lord Macaulay's English," and other literary themes; and others still, on strictly philological subjects, such as "The Origin of the Teutonic Weak Preterite;" but these we can only allude to. There were also some essays with a distinctly local flavor; in particular, one by Professor Fortier on "Louisiana Folk-Lore," and another by Professor Primer on "Charleston Provincialisms;" both of which will be interesting not only to philologists, but to many others. It seemed to be the sentiment of the members present that the study of such local themes is specially incumbent on American philologists, the more so because local and dialectal peculiarities are fast disappearing under the influence of the common schools. The essays as a whole betray two distinct tenden-

cies, — the philological and the literary; or, in other words, the scientific and the æsthetic; and in some of the discussions that followed the reading of each paper these two tendencies came into collision. There seems, however, to have been great harmony of feeling at the meeting, notwithstanding many divergences in views. We are glad to add that the association passed a resolution in favor of repealing the tariff on foreign books; and we should be happy to record a similar act on the part of Congress.

— Miss Dora Wheeler, the well-known decorative artist, has given much of her spare time during the past two or three years to painting, either in pastel or oils, a series of portraits of authors here and abroad, many of whom are numbered among her personal friends. Unfortunately several of those of English authors who had given her sittings during her stay in London, in 1886, including Mrs. Thackeray Ritchie, Mr. Walter Besant, Mr. Thomas Hardy, and Mr. Austin Dobson, whose further acquaintance the American public is always glad to make, were lost in transit. Since that time her sitters have been exclusively American authors; and she has finished, or nearly finished, portraits of Mrs. Stowe, Mrs. Burnett, Mr. Lowell, "Mark Twain," Mr. Warner, Mr. Howells, Mr. Aldrich, Mr. Stockton, Mr. Burroughs, Walt Whitman, and others. The interesting announcement is made that these portraits will be given as frontispieces through the year for *The Literary News*, New York. Mrs. Stowe is portrayed in the January number, and Mrs. Burnett will be given in that for February.

— Ensign Hayden's nautical monograph No. 5, just published by the Hydrographic Office, is a graphic and picturesque report of the famous March blizzard. It is illustrated with four maps showing the advance and culmination of that extraordinary atmospheric convulsion.

— Mr. von Lindheim, an Austrian engineer, has compiled the statistics of street railroads in Europe. The development of such roads dates back not more than fifteen or twenty years. In England, France, Germany, Belgium, Holland, Austria, and Switzerland there are 221 cities having street-railroads. Among these, 118 are in England, 43 in Germany, and 23 in France, there being no city of less than twenty thousand inhabitants having such roads, while in the United States they are found in cities of not more than one thousand inhabitants. In Europe there existed in 1886-87 4,330 miles of street-railroads, while the United States had 5,932 miles. England had 883 miles on which 416,518,423 passengers were carried. In Germany 245,657,503 passengers were carried on 523 miles of road. In England 472,356 passengers were carried over each mile; in Germany, 468,874; in France, 545,815. There were 3,345 street-cars in Germany, 3,494 in England, and 2,780 in France, against 22,940 in the United States. In the latter, 92,203 horses, 12,217 mules, and 248 locomotives were in use on street-roads. Of considerable interest is the comparison of distance travelled each day by the horses. In Berlin a horse gives an average of 16.1 miles; in Posen, even as much as 16.7 miles; in Vienna, 14.5 miles; in Paris, 9.9 miles; and in Hamburg, 13.7 miles. The use of mechanical motors in place of horses is steadily increasing. It is particularly desirable in those places where the daily variations of traffic are considerable. In Berlin, for instance, the Sunday and holiday traffic is 27 per cent of the whole, and in Vienna even amounts to 34 per cent, while on Wednesday the street-cars are very little used. Mr. von Lindheim is a strong advocate of the use of electric traction in street-railroads, and states that in Europe the cost of horse-traction is 1.47 if that of electric traction is assumed as 1.

— Ticknor & Co. announce among their January books, "Steadfast," by Rose Terry Cooke; "Great Captains," by Col. Theodore Ayrault Dodge, U.S.A., — a series of six lectures delivered before

THE MOST PRACTICAL AND POPULAR OF THE MANY EXCELLENT TEXT-BOOKS RECENTLY PUBLISHED ON THIS SUBJECT.

Published less than one year ago, and already adopted for use in a large number of the leading High Schools, Normal Schools, Seminaries, Academies, etc., of the country.

MOWRY'S STUDIES IN CIVIL GOVERNMENT.

INTRODUCTORY PRICE, 94 CENTS.

SILVER, BURDETT & CO. Publishers, 50 Bromfield St., Boston.

NEW YORK: 740 & 742 Broadway.

CHICAGO: 122 & 124 Wabash Ave.

"Mowry's 'Studies in Civil Government' is the best book yet on the subject," A. S. Roe, *Principal of High School, Worcester, Mass.*

"A sample copy will be mailed to any teacher for examination on receipt of Introductory Price (94 cents). Examine Mowry's 'Studies in Civil Government,' before beginning with another class.

the Lowell Institute, Boston, in 1889, devoted to Alexander, Hannibal, Cæsar, Gustavus Adolphus, Frederick, Napoleon, and the record of their achievements and the analysis of what each of them contributed to military science; "Ancient and Modern Light-Houses," by Major D. P. Heap, Corps of Engineers, U.S.A.; a new edition of "Discourses on Architecture," by E.-E. Viollet-Le-Duc, richly and copiously illustrated with hundreds of steel engravings and woodcuts, translated from the French by Benjamin Bucknall; a new and cheaper edition of "A Hand-Book of Christian Symbols and Stories of the Saints, as illustrated in Art," by Clara Erskine Clement and Katherine E. Conway; and "His Two Wives," a novel, by Mary Clemmer, being No. 50 of Ticknor's Paper Series.

LETTERS TO THE EDITOR.

*Correspondents are requested to be as brief as possible. The writer's name is in all cases required as proof of good faith.

Twenty copies of the number containing his communication will be furnished free to any correspondent on request.

The editor will be glad to publish any queries consonant with the character of the journal.

Dew-Point and Predictions of Weather.

ONE of the most serious drawbacks to a discussion and utilization of humidity records has been the lack of proper observational methods, and also of tables of reduction. As late as 1884 we find in Guyot two distinct tables for reducing observations with the psychrometer (the usual instrument for determining humidity) which give results differing by more than sixty degrees at extreme dryness. Perhaps nothing can indicate better the hopelessness, as late as 1887, of nearly all attempts at solving the problem of the relation between the dry and wet thermometers and the dew-point, than the announced determination of the meteorological committee to omit a table for the psychrometer from their compendium of tables for international use. It will be generally admitted that such a table is the most important and most needed of any in meteorology. The most serious difficulty in nearly all investigations has been a lack of ventilation of the psychrometer.

In September, 1883, the sling psychrometer, which combines all the admirable qualities of perfect ventilation and accuracy, great speed of action, and extreme portability, was adopted in this country.¹

With this the true relation between the quantities mentioned above was determined in 1884, and published in February, 1885; and this has been used in the latest tables, leaving nothing now to be desired except observations to check the formula at extreme dryness, such as does not occur east of the Rockies.

I propose to discuss a few recent observations with the sling psychrometer. It might be a question as to the best form in which to study the moisture of the air. The relative humidity, the difference between the dew-point and air temperature, the dew-point itself, the absolute humidity, and the vapor pressure, have all had advocates. It may be remarked that the second of these, being a deduction from two quantities which are often rapidly varying in opposite directions, seems a little uncertain. The fourth and fifth are similar to the third.

The following propositions regarding the dew-point are set forth: 1. The diurnal change in air temperature does not affect the dew-point; 2. The temperature change from day to day does not change the dew-point; 3. The air temperature is generally very near the dew-point at sunrise, and farthest from it at 2 or 3 P.M.; 4. The air temperature in its fluctuations from day to day follows the dew-point; 5. Direction and velocity of the wind do not in general affect the dew-point; 6. The same may be said of fluctuations in air-pressure; 7. The most marked rise in the dew-point occurs on the approach of a storm having an abundance of rain and during rain itself (the time of beginning and ending of rain cannot be foretold from the dew-point); 8. The most marked fall in the dew-point is caused by the advance of a high area, as was to be expected; 9. The most marked feature of the dew-point is its constancy, though at times it has a range in several days far greater than the air temperature, yet it quickly recovers from a fall

¹ My attention has just been called to the use of a sling psychrometer by Espy in Philadelphia in 1834. His results, which were not entirely satisfactory, were far ahead of his time, and till quite recently exceeded in accuracy all others since. As is so often the case, they seem to have attracted little or no attention.

or rise to a normal position, depending on the season and other general causes; 10. The dew-point is the same in all parts of a quite extended region.

The fourth of these is one of the more important, and seems to follow from the third. We have usually been taught that the air temperature on a clear night will continue to fall till the dew-point is reached, when there will be condensation of moisture, and liberation of latent heat, which will prevent the further fall in temperature; but it will be found, that, except after a long rain and in a fog, the air temperature never reaches the dew-point. Very often on clear nights the latter falls, and draws the former after it. If this proposition can be established, there may be a chance to predict changes in air temperature from the dew-point, though they are very close together.

On many accounts the seventh proposition is the most interesting of all. Does the atmosphere in this case gradually sink down? This usually would increase the dryness. The wind does not appear to carry the moisture, for this steady rise occurs in a calm. Moreover, the direction of the wind, as coming from the earth's surface, makes little or no difference. It is very evident that the dew-point cannot be used in predicting rain. Under the eighth proposition it should be noted that the fall in the dew-point ceases in a few hours, and long before the pressure has reached a maximum. The figures from which these propositions arise will shortly be published elsewhere. It would be gratifying if others are stimulated to make similar research.

H. A. HAZEN.

Washington, Jan. 16.

Horns of the Prong-Buck (*Antilocapra*).

THE other evening, while reading an article on the *Artiodactyla*, by Professor Cope, in the *American Naturalist* for December, 1888, I was much surprised at finding the following note: "Antilocapra is sometimes separated from the Bovidæ as the type of a family, because it is said to sometimes shed its horn-sheath. This character, *were it really normal*, has no significance sufficient for the establishment of a family division" (*Italics mine*).

This doubt as to the shedding of the horn-sheath was so entirely foreign to what I had been led to believe, both by observation and reading, that I took the pains to look over what little literature I possess touching the subject; and, finding it so uniformly in favor of the shedding theory, I write, asking if your readers can give any additional facts in the case.

Owen (*Anatomy of Vertebrates*, London, 1868, vol. iii. pp. 626, 627) gives a description of the shedding of the horns, and growth of new ones, noticed by Mr. Bartlett in the Zoological Gardens of London in 1865; also notes of Dr. Canfield at Monterey, Cal., from 1855 to 1857, on a young male in captivity. Dr. Canfield is also quoted: "In the months of December and January I have never killed a buck with large horns; and at that time of the year all the bucks appear to be young ones, because their horns are so small; whereas in the spring and summer months almost all the bucks appear to be old ones, for their horns are then large and noticeable." Dr. Canfield also states that "in the summer months the line of demarcation between the horn and skin from which it grows is very apparent and abrupt; whereas in winter there is no demarcation, the horn being very soft at its base, and passing insensibly into cuticular tissues, and the horny substance being covered thinly with hair."

Gill (*Arrangement of the Families of Mammals*, Washington, 1872, p. 72) says of *Antilocapridæ*: "Horns deciduous, peculiar to the rutting-season (in both sexes), developed as pseudocorneous sheaths, with agglutinated hairs on osseous cores originating from the frontal bones." Gray (*Hand-List of the Edentata, Thick-skinned, and Ruminant Mammals in the British Museum*, London, 1873, p. 135) evidently believes in this shedding, because he places *Antilocapra* under a separate sub-order, *Dicranocera*, instead of merely a separate family. Mivart (*Lessons in Elementary Anatomy*, London, 1883, pp. 245, 246), on ederonic appendages, says, "and only in an anomalous form, the prong-buck (*Antilocapra*), are these horny structures shed at intervals;" Huxley (*A Manual of the Anatomy of Vertebrate Animals*, New York, 1883, p. 327), "But in the remarkable prong-horned antelope of North America (*Antilocapra*) the horny sheath is annually shed,

and replaced by a newly formed one." Caton (*The Antelope and Deer of America*, 2d ed., New York, 1881 [?]) gives a lengthy description of the shedding process as observed by him upon antelope in captivity; also quotes Audubon and Bachman (*Quadrupeds of America*) as saying, "It was supposed by the hunters of Fort Union that the prong-horned antelope dropped its horns,"—a supposition that these naturalists thought they had disproved by merely showing that it had an osseous horn-core. E. R. Alston (*Biologia Centrali-Americana*, 1879-82, p. 112, article "Mammalia") says, "Although the fact that the prong-buck sheds its horns annually was long well known to hunters and backwoodsman, and had been noted by one or two writers, yet it was generally disbelieved or ignored by zoölogists; and Mr. Bartlett, the observant superintendent of the Zoological Society's Gardens, was the first to demonstrate its truth and insist on its importance." Flower (*Encyclopædia Britannica*, 9th ed., p. 431, article "Mammalia") says, "The only existing species [of the *Bovidae*] in which such a process [shedding] occurs regularly and periodically is the American prong-buck (*Antilocapra*), in which the horns also differ from all others in being bifurcated."

This evidence resolves itself into three separate cases of direct observation on animals in captivity,—the statement by Audubon and Bachman of the belief of the hunters of Fort Union; and the indefinite statement of Mr. Alston, that "the fact that the prong-buck sheds its horns annually was long well known to hunters and backwoodsman."

My own observations are as follows. I have several times handled skins of this animal from the Western plains, from which the horn-sheath could easily be drawn, exposing to view a partially formed horn beneath. These, I have every reason to believe, were wild animals. I think, at the least, I have examined six or eight such cases; also I have noticed many cases in which the horn-sheath insensibly graded into skin, and was covered with hair for a considerable distance from its base, and many other cases where the demarcation was sharply drawn. Unfortunately I cannot recall at what seasons of the year these animals were killed. Again: in two or three cases have I known of taxidermists, uninformed that the phenomenon was known, coming to an independent conclusion that the antelope sheds its horns.

Now, let us see what the evidence amounts to. The generally accepted belief that confinement effects moultings must be taken into account; but, as far as I am aware, there is nothing in this evidence that would lend any support whatever to the idea that it could produce such a remarkable change as that of a permanently horned *Cavicornia* changing to a deciduous one. However, those antelope kept by Dr. Canfield and Judge Caton can hardly be strictly classed as animals in confinement. That of Dr. Canfield used to go hunting with him as far as twelve miles from home, we are told, and "hunted coyotes with the dogs at night;" while those of Judge Caton had the run of a large park. Neither can a change of climate or natural food be called in to account for this moult as described by Dr. Canfield, for his buck was living in its native habitat.

The opinion of the hunters of Fort Union is of considerable value. While hunters, Indians, etc., are not good at distinguishing species, yet habits, when well marked, are usually much more familiar to them as a class than to naturalists.

My own observations on prepared skins also point very strongly toward the same conclusion. In no manner did these indicate an abnormal physical state. Those observed in the United States in captivity evidently were healthy; and so good an observer as Mr. Bartlett would hardly have failed to have stated the fact if the specimen under his care was in poor health. That bucks killed in December and January all have short horns, grading insensibly into skin, and with base covered with hair, while those killed in the spring and summer months almost all have large horns, definitely marked off from the skin, can, I think, be explained in no other way than by an annual moult. That such is the almost universal belief of naturalists, my citations tend to show.

As the point is one of considerable interest, I have ventured to take up so much of your space, hoping thereby to call out some original observations from your readers. HENRY L. WARD.

Tacubaya, D.F., Mex., Jan. 10.

Felspar, or Feldspar?

I HAVE read with interest the recent notes in *Science*, Nos. 305, 306, and 309, on the orthography of "felspar" or "feldspar."

Whether the error consists in the omission or in the insertion of the *d*, seems doubtful. But apart from "national prejudice" in the matter,—which, if it exists elsewhere than in the imagination of your correspondent, "J. D. D.," is certainly to be deprecated,—there are, it seems to me, good reasons for defending and adopting the British custom of spelling the word. These are based on probability, common sense, and, last, though not least, appropriateness.

It may, I think, if there is no proof to the contrary, be admitted that the name was originally given by a miner, or a mineralogist, and not by an agriculturist; and, if so, then it is in the highest degree improbable that either the miner or the mineralogist would associate this particular substance with the fields, with which it has no obvious connection, and it is in an equal degree probable that he would associate it with the rocks of which it is one of the chief constituents. In any case, the British custom of referring it to *fels*, or *felsen* ("a rock," "rockspär") is both sensible and appropriate, neither of which can be said of its reference to *feld* or *felt* ("a field," "feldspär").

On these considerations alone, and not because of "national prejudice," or even custom, I consider it advisable to adhere to the spelling adopted by nearly all English geologists until some better reason than mere assertion, or the custom elsewhere, is advanced for not doing so.

ALFRED R. C. SELWYN.

Ottawa, Can., Jan. 14.

The Soaring of Birds.

PROFESSOR PICKERING may possibly have the correct explanation of the soaring of birds; and, if so, will he be kind enough to explain it more strongly, so that the explanation may have the force of a demonstration in geometry? As it now stands, there appears to be a fallacy somewhere.

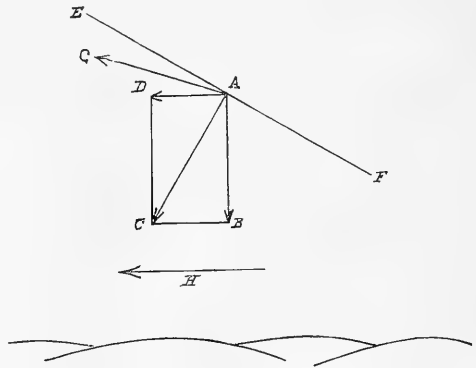

If the bird is acted on by two forces, *AB* and *AD*, the resultant force would carry him to *C*; and he could by no means get to *G* except by the action of a third force, which might be represented by a line drawn from *C* to *G*. Professor Pickering makes no mention of any such third force, but without it how could the bird get to *G*?

WM. KENT.

Passaic, N.J., Jan. 12.

The Color of Katydid.

I OBSERVE in *Science* of Jan. 11 mention of a pink katydid found by L. N. Johnson, Evanston, Ill. A large female specimen was found on my place at Wood's Holl, Mass., as early as 1874, and sent to Professor Packard. Two others have been found at the same place, so that it would seem to be a defined species.

JOS. STORY FAY.

Boston, Mass., Jan. 21.

Publications received at Editor's Office, Jan. 7-19.

- BALZAC, H. de. Louis Lambert. Tr. by Katherine P. Worneley. Boston, Roberts Bros. 258 p. 12". \$1.50.
- CORY, C. B. The Birds of the West Indies. Boston, Estes & Lauriat. 324 p. 8".
- LANGLEY, S. P., Address of, at the American Association for the Advancement of Science, at the Cleveland meeting, August, 1888. Salem, Salem, Pr. 23 p. 8".
- NATIONAL Geographic Magazine, The. Vol. I. No. 1. Washington, Nat. Geog. Soc. 68 p. 8". 50 cents.
- NEW YORK State Museum of Natural History. Forty-first Annual Report of the Trustees of the, for the Year 1887. Albany, State. 300 p. 8".
- PALMER, C. T., Artificial Persons. A Philosophical View of the Law of Corporations. Chicago, Open Court Publ. Co. 16 p. 12".
- PETER, R. Chemical Report of the Coals, Soils, Clays, Petroleum, Mineral Waters, etc., of Kentucky. (Geol. Surv. Ky., Vol. A, Part III.) Frankfort, Ky. State. 171 p. 8".
- U. S. GEOLOGICAL SURVEY. Topographical Maps of Portions of Alabama, Georgia, Kansas, Missouri, Massachusetts, South Carolina, Tennessee, Texas, Virginia, and West Virginia. 16 maps, 42 by 50.5 cm. Washington, Government, 1889.
- WICKSTEED, P. H. The Alphabet of Economic Science. Part I. Elements of the Theory of Value or Worth. London and New York, Macmillan. 142 p. 16". 60 cents.
- WILLIAMS, A., Jr. Useful Minerals of the United States. Washington, Government, 82 p. 16".
- YOUNG, C. A. A Text-Book of General Astronomy for Colleges and Scientific Schools. Boston and London, Ginn & Co. 557 p. 8". \$2.40.

16 PAGES. THREE 16 PAGES.

Hundred Thousand new subscribers for *The Family Journal* and *Ladies' Companion* wanted. It is the most interesting and instructive paper ever issued. Subscribers will receive during the coming twelve

MONTHS

novels written by American Authors, complete in each three numbers. The story of popular works of fiction will be retold by a novel reader, the most interesting and instructive paper ever issued. In any publication, giving the substance of popular and standard books by famous writers in a space easily read by the busiest people. We have engaged

FOR

this work a widely known and popular writer. Comments on Current Events, Fashions, New and Original Ideas and Designs for Ladies' Fancy Work and Household Decorations, Letters from Correspondents and their Answers. The colleges and seminaries of the United States will be treated one each month in an illustrated article, showing the particular advantages of each, cost of attendance, etc. Invaluable to parents having sons or daughters whom they desire should receive the advantages of a higher education than the ordinary school affords. Articles on Painting and Drawing, giving home instruction by a well-known artist. A trial subscription of this elegant paper will be sent to any address, three months, for

TEN CENTS.

Liberal pay for literary work adapted to our columns, and for new and original drawings, designs and ideas on any subject which we can use.

Premium List the most complete in the world. We offer inducements to club raisers and agents approached by no other publishing house. The celebrated Gilbert Chestnut Liners, which we send post paid to any one sending us two yearly subscribers at 40 cents, a trial subscription of this elegant paper will be sent to any address, post paid one year, 50 cents; six months, 25 cents, and a three months' trial subscription for only 10 cents.

TRY IT! TRY IT! TRY IT!
and you will become a permanent reader. Address:
John L. Douglass, Publisher,
322 Broadway, N. Y.

A TEMPORARY BINDER

for *Science* is now ready, and will be mailed postpaid on receipt of price.



- Cloth - - - 50 cents.
- Half Morocco - - 75 cents.

This binder is strong, durable and elegant, has gilt side-title, and allows the opening of the pages perfectly flat. Any number can be taken out and replaced without disturbing the others, and the papers are not mutilated for subsequent permanent binding. Filed in this binder, *Science* is always convenient for reference.

N. D. C. HODGES,
47 Lafayette Place, New York.

THE American Bell Telephone COMPANY.
95 MILK ST., BOSTON, MASS.

This Company owns the Letters Patent granted to Alexander Graham Bell, March 7th, 1876, No. 174,465, and January 30, 1877, No. 186,787.

The Transmission of Speech by all known forms of ELECTRIC SPEAKING TELEPHONES infringes the right secured to this Company by the above patents, and renders each individual user of telephones, not furnished by it or its licensees, responsible for such unlawful use, and all the consequences thereof and liable to suit therefor.

ELECTRICAL TESTING BUREAU,

- Johns Hopkins University, Baltimore, Md.
- Resistance Coils and Boxes Compared.
- Am meters and Volt meters calibrated.
- Condensers standardized.
- Primary and Secondary Batteries Tested.
- Efficiency of Dynamos and Motors Determined.
- Insulation of Cables and Wires Tested.
- Etc., Etc.
- Circulars describing Methods Used, Prices, Etc., sent on Application.
- Address as above.

R. ELLIS & CO.

BUSINESS, HOTEL AND PATENT BROKERS,
AUCTIONEERS, ETC.

No. 176 BROADWAY,

Room 46. **New York.**

CLIENTS Advised free of charge.

ESTABLISHED 1859.

H. A. DREW,
Commercial Printer,
5 Clinton Place, near Broadway,
New York.

Wedding Orders, Souvenirs, Invitations, Orders of Dance, etc., etc., done in the latest and most elaborate styles, at reasonable prices. All Favors promptly attended to.

SCIENCE CLUBBING RATES.

10% DISCOUNT.

We will allow the above discount to any subscriber to *Science of the Swiss Cross* who will send us an order for periodicals exceeding \$10, counting each at its full price.

	Subscription.	With Science.	With The Swiss Cross.
American Agriculturist.....	\$ 1.50	\$ 4.30	\$ 2.25
American Analyst.....	1.00	4.25	2.20
American Architect and Building News.			
Imperial edition.....	10.00	12.80	11.00
Gelatine.....	7.00	9.80	8.00
Regular.....	3.00	5.80	7.00
American Garden.....	1.00	4.25	2.25
American Journal of Physiology.....	3.00	6.25	4.25
American Machinist.....	2.50	5.30	4.50
American Magazine.....	1.00	4.30	5.00
American Naturalist.....	4.00	7.50	5.50
Andover Review.....	4.00	6.80	5.00
Atlantic.....	4.00	6.80	5.00
Babyhood.....	1.00	4.30	2.50
Babland.....	5.00	3.75	1.75
Bradstreet's.....	5.00	6.80	6.00
Brain.....	3.50	3.60	4.50
Building (weekly).....	3.00	5.80	4.00
Carpentry and Building.....	1.00	4.25	2.25
Century Magazine.....	4.00	6.80	5.00
Chautauquan, The.....	1.50	4.30	2.50
Christian Union.....	1.00	4.30	2.50
Christian Weekly, Illustrated.....	2.50	3.30	3.50
Cosmopolitan, The.....	2.00	4.80	3.00
Critic.....	3.00	5.80	4.00
Electrician.....	3.00	5.80	4.00
Electric Magazine.....	5.00	8.80	6.00
Edinburgh Review.....	4.00	6.80	5.00
Electrical World.....	3.00	5.80	4.00
Electrical Engineer.....	3.00	5.80	4.00
Electrical Review.....	1.00	4.80	4.00
Engineering and Mining Journal.....	4.00	6.80	5.00
English Illustrated Magazine.....	1.75	4.55	2.75
Family Story Paper (N.Y.).....	3.00	5.80	4.00
Forest and Stream.....	1.00	4.80	3.00
Forum, The.....	5.00	7.80	6.00
Godey's Lady's Book.....	2.00	4.80	3.00
Harper's Bazar.....	4.00	6.80	5.00
Harper's Magazine.....	4.00	6.80	5.00
Harper's Weekly.....	4.00	6.80	5.00
Harper's Young People.....	2.00	4.80	3.00
Health and Home.....	1.00	4.25	2.25
Herald of Science.....	1.00	4.25	2.25
Illustrated London News (Amer. reprint).....	4.00	6.80	5.00
Independent, The.....	3.00	5.80	4.00
Inten Ocean, The.....	3.00	5.80	4.00
Iron Age (weekly).....	4.50	7.30	5.50
Journal of Physiology (Eng.).....	2.50	3.30	3.50
Journal of Speculative Philosophy (begins with Jan. No.).....	3.00	5.80	4.00
Judge.....	4.00	6.80	5.00
L'Art.....	12.00	14.80	13.00
Life.....	5.00	7.80	6.00
Literary Digest.....	3.00	5.80	4.00
Littell's Living Age.....	8.00	10.80	9.00
Little Men and Women.....	1.00	4.25	2.25
London Quarterly.....	4.00	6.80	5.00
Macmillan's Magazine.....	3.00	5.80	4.00
Magazine of American History.....	5.00	7.80	6.00
Medical and Surgical Journal.....	5.00	7.80	6.00
Mechanical Engineer.....	2.00	4.80	3.00
Metal Worker.....	1.00	4.25	2.25
Microscope, The.....	1.00	4.25	2.25
Nature.....	6.00	8.80	7.00
New Princeton Review.....	3.00	5.80	4.00
North American Review.....	5.00	7.80	6.00
Outing.....	3.00	5.80	4.00
Overland Monthly.....	4.00	6.80	5.00
Pansy.....	1.00	4.25	2.25
Political Science Quarterly.....	3.00	5.80	4.00
Popular Science Monthly.....	1.00	4.25	2.25
Popular Science News.....	1.00	4.25	2.25
Portfolio, The.....	7.50	10.30	8.50
Practitioner.....	3.50	6.30	4.50
Public Opinion.....	1.00	4.25	2.25
Puck.....	5.00	7.80	6.00
Puck (German).....	5.00	7.80	6.00
Quarterly Review (London).....	4.00	6.80	5.00
Queries.....	1.00	4.25	2.25
Rural New-Yorker.....	2.00	4.80	3.00
St. Nicholas.....	3.00	5.80	4.00
School Journal.....	2.50	5.30	3.50
Scientific American.....	5.00	7.80	6.00
Supplement.....	5.00	7.80	6.00
Architect and Builders' edition.....	2.50	5.30	3.50
Scribner's Magazine.....	3.00	5.80	4.00
Southern Cultivator.....	1.50	4.25	2.25
Springfield Republican (weekly).....	1.00	4.25	2.25
Sunday School Times.....	2.00	4.80	3.00
Teachers' Institute.....	1.25	4.05	2.25
Texas Siftings.....	1.00	4.80	3.00
Treasure-Trove.....	1.00	4.25	2.25
Truth Seeker, The.....	3.00	5.80	4.00
Wide Awake.....	2.40	5.20	3.40
Young Folks' Journal.....	1.00	4.25	2.25

N. D. C. HODGES,
47 Lafayette Place,
New York.

Insurance.

DELAY IS DANGEROUS.

We call attention to the new form of Accident (indemnity) Insurance policies, which are written by the Merchant's Casualty Insurance Association, at Park Row, New York City, John S. Purdy, Secretary. These policies cover weekly allowances of from \$10 to \$25, according to occupation, at a cost of only \$6 a year exclusive of the cost to join, which is \$5 payable once only. The public, as a rule, carry life insurance, and the ordinary accident policies issued by companies, paying a sum in case of death, is not so desirable as one of these indemnity policies in case of accidents, which are so plentiful in this fast age with its railroad horrors, fast driving, electric wires and other countless forms of dangero to which the public is constantly exposed. The fact of the Association having no unpaid claims, and its having just passed an examination by the Insurance Department of New York State, shows that the management is liberal with its policy-holders and conservative in its action. The Association also desires to secure energetic Agents in every village and town, to whom territory and favorable terms will be given.

Theatres.

BROADWAY THEATRE. Corner 41st St.
MANAGER.....MR. FRANK W. SANGER.
LITTLE LORD FAUNTLEROY.
Evenings at 8. Mat. Sat. at 2.

LYCEUM THEATRE. 4th Av. and 23d St.
Daniel Frohman.....Manager.
SWEET LAVENDER.

MADISON SQUARE THEATRE.
Mr. A. M. Palmer.....Sole Manager.
CAPTAIN SWIFT.

PALMER'S THEATRE. B'way and 30th St.
MRS. POTTER.
Scale of prices, \$2, \$1.50, \$1, and 50 cents.

A Useful and Handsome Present.

Prices Reduced for the Holidays.



Warranted 14 karat gold and to give perfect satisfaction—is pronounced by hundreds of pleased customers to be the best fountain pen in the market because it is always ready. Writes freely and never gets out of order.
Sent by mail prepaid for \$1.50, \$2.00 and \$2.50 each, according to size selected.

These are special prices for the holidays, and this offer should be availed of by all who write.

JOHN S. HULIN,
Mfg Stationer and Steam Printer.
Wedding Invitations and Visiting
Cards Engraved to Order,
369 BROADWAY, N. Y.
Near Franklin Street.

The Largest, Handsomest, and Most Complete
Account-Book Manufactory and Printing Estab-
lishment for Fine Commercial Work in New
York City.

Readers of Science

Corresponding or visiting with Advertisers, will confer a great favor by mentioning this paper.

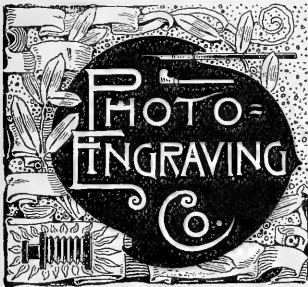

BRANCH AT 728 CHESTNUT ST.
PHILADELPHIA. PA.

JOHN HASTINGS = Frest.
A=R=HART = Genl Manager.
JOS=TRIPP = V Prest.

ENGRAVING FOR
ALL ILLUSTRATIVE
AND ADVERTISING
PURPOSES

67-71 PARK PLACE,
NEW YORK.

ONE LANGUAGE FOR THE WHOLE WORLD.

WORLD-ENGLISH :

THE UNIVERSAL LANGUAGE. 25 CENTS.

EVERY one has heard of the butcher who, after a long search for his knife, at last found it in his mouth : so speakers of English have been seeking for a universal language, when, lo ! it is in their mouths. The intelligibility of English words has been obscured by a dense mist of letters. This is now dispersed by A. Melville Bell, who has already won a world-wide reputation through his invention of "Visible Speech," the great boon to deaf-mutes. Professor Bell calls this new discovery of his "World-English," and the result is a language which cannot fail to meet with acceptance, and at once supersede the supposed necessity for "Volapük," or any other artificial language. No language could be invented for international use that would surpass English in grammatical simplicity, and in general fitness to become the tongue of the world. It is already the mother-tongue of increasing millions in both hemispheres, and some knowledge of the language is demanded by all educated populations on the globe. Social and commercial necessities require that the acquisition of this knowledge shall be facilitated, and it is believed that Professor Bell's invention has removed the last impediment to English becoming the universal language, for which vague desires have long been entertained, although hitherto only futile efforts have been made.

Ex-President Andrew D. White, of Cornell University, says: "I believe that the highest interests of Christian civilization and of humanity would be served by its adoption. China and Japan would be made English-speaking peoples within fifty years, and so brought within the range of Christianizing and civilizing ideas, in the largest sense. All existing missionary work is trivial as compared with this. For your system would throw wide open those vast countries, as, indeed, all the countries of the world, to the whole current of English and American thought."

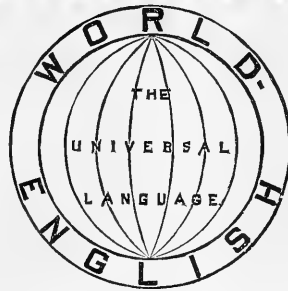

For Diffusion of English throughout the World

AS
THE UNIVERSAL LANGUAGE

This "Hand-Book of World-English" is the Complete, Simple, and Efficient Medium.

FOREIGNERS

Will Acquire, by Means of this Hand-Book, a
PERFECT PRONUNCIATION OF ENGLISH.
For Primary School Pupils and Illiterate Adults

World-English is a Royal Road to Reading.

To Teachers of English and Modern Languages

This Hand-Book will be of Primary Importance as a Phonetic Directory.

DEFECTS OF SPEECH

Will be Readily Corrected by Means of the Articulate Directions in this Hand-Book.

HAND-BOOK OF WORLD-ENGLISH,

25 CENTS.

The plan of this little book is altogether new. Letters and sounds are so associated, in all the exercises, that from the mere knowledge of letters a learner cannot fail to pronounce words with certainty. English reading will thus be easily acquired, whether by natives or foreigners, children or adults.

The general resemblance of World-English to Literary English is such that any reader of the latter deciphers the former at sight, or, at most, after a few minutes' study of the new letters. A like result may be anticipated for those who shall learn to read from World-English. They will transfer their power of reading to the literary form of the language, almost without effort. The orthographic aspect of words will, besides, be so fixed in the eye, by contrast, that spelling will be remembered as — what it really is — a pictorial association with words.

No special training is required to qualify teachers for using this book. The subject can even be successfully introduced in the kindergarten and the nursery. This phonetic mode of initiation in reading cannot be too strongly urged on the attention of School Boards on both sides of the Atlantic.

The ordinary orthography of each word is interlined with the World-English version throughout the Exercises and Readings.

So set down, our tongue is the best for the world to unite upon.—*Brooklyn Eagle.*

The idea of Mr. Bell has much to recommend it, and the presentation is charmingly clear.—*American, Phila.*

The result is a language which cannot fail to meet with acceptance.—*Boston Transcript.*

Has the merit of great ingenuity.—*Railway Age.*

His treatise, as a study of English orthoepy, condenses the result of much thought and experience in small compass.—*The Critic.*

World-English deserves the careful consideration of all serious scholars.—*Modern Language Notes.*

World-English is the English language unburdened of its chaotic spelling.—*Popular Science Monthly.*

We commend it to the attention of teachers.—*Ottawa Globe.*

"World-English" and "Hand-Book of World-English" can be had of all booksellers, or will be sent for 50 cents, post free, by the publisher,

N. D. C. HODGES, 47 Lafayette Place, New York.

DR. WARNER'S



CAMELS HAIR

HEALTH UNDERWEAR

FOR MEN WOMEN AND CHILDREN.

Superior to Silk or Wool.
A Protection against Colds, Neuralgia and Rheumatism.

SOLD BY LEADING MERCHANTS.
WARNER BROS., 359 Broadway, New York.

EVENING SILKS.

We have just received several cases of Novelty Silks for evening wear, specially intended for the approaching season. The ground colors are white and various delicate gaslight shades, and are brocaded in Silver and Gold in very unique designs.

Orders by mail will receive careful and prompt attention.

JAMES McCREERY & CO.

BROADWAY AND ELEVENTH ST.,
NEW YORK CITY.

THE GREAT AMERICAN TEA COMPANY

GOOD NEWS TO LADIES.

Greatest inducements ever offered. Now's your time to get up orders for our celebrated Teas and Coffees, and secure a beautiful Gold Band or Moss Rose China Tea Set, Dinner Set, Gold Band Moss Rose Toilet Set, Watch, Brass Lamp, or Webster's Dictionary. For full particulars address **THE GREAT AMERICAN TEA CO.,** P. O. Box 289, 81 and 83 Vesey St., New York.

ESTERBROOK'S STEEL PENS.

OF SUPERIOR AND STANDARD QUALITY.
Leading Nos.: 048, 14, 130, 135, 239, 333

For Sale by all Stationers.

THE ESTERBROOK STEEL PEN CO.,
Works: Camden, N. J. 26 John St., New York.

Arnold, Constable & Co.

LINENS

AND
HOUSEKEEPING GOODS.
DAMASK TABLE CLOTHS,
Damask Napkins, Linen Sheetings,
PILLOW LINENS.
DAMASK AND HUCK TOWELLINGS,
At prices very advantageous to the purchaser.

Broadway & 19th St.
New York.

J. GRUNOW,

621 Sixth Avenue, New York.
Established 1852.

MAKER OF

Microscope Stands,
Oil Immersion Objectives and Abbe Condensers for Bacterial and Histological work, of Objectives, Camera Lucida and other accessories apparatus.

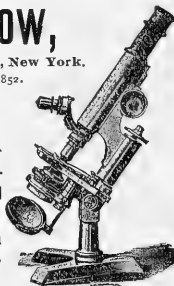

IMPROVED OIL LIGHT MAGIC LANTERNS.

Also Lime and Electric Light Apparatus, and mechanical, plain, and fine colored views.

J. B. COLT & CO., Manufacturers,
No. 16 BEEKMAN STREET, NEW YORK.

WHITALL'S PLANISPHERES OF THE STARRY HEAVENS name and locate all Planets, Stars, and Constellations visible at any given minute of time. Every one should possess set, \$5.00; Miniature, 30 cents postage paid. Ask stationer, or address Wm. T. Cooper, Manager, 307 Race St., Philadelphia, Pa.

MAGIC Stereopticons and the Best Views for Public, Church, Home, and Scientific Exhibitions. Best apparatus, new views. Largest stock. Reduced prices. 24 Years' Practical Experience. Illus. Catalogue Free.

GEO. H. PIERCE,
136 S. Eleventh St., Philadelphia, Pa

Schools.

CONNECTICUT, NEW HAVEN,
MRS. CADY'S SCHOOL FOR YOUNG LADIES.
Prepares for Smith and Wellesley, and admits to Vassar by Certificate. Circulars. Early application necessary.

VERMONT, BURLINGTON.
VERMONT EPISCOPAL INSTITUTE. Boarding School for Boys. Prepares for College or Business-Military drill. Terms moderate. Fifty-seventh half-year opens September 3, 1888. Send for catalogue.
H. H. ROSS, A.M., Principal.

Wants.

WANTED.—A teacher for the Natural Sciences and History, who is also competent for the position of Associate Principal, in a flourishing private school. Address P. O. Box 385, Plainfield, N.J.

A Harvard graduate desires engagement as teacher of higher English branches, such as composition, rhetoric, literature, history, political economy, mathematics.

Address J. B. H.,
SCIENCE OFFICE.

SCHOOLS AND COLLEGES
will have a positive advantage by ordering their furniture apparatus and supplies from
C. PARDO & CO.,
37 East 17th St., New York.

Scientific Apparatus.

W. H. WALMSLEY & CO.
SUCCESSORS TO
R. & J. BECK,

1016 Chestnut Street Phila
Microscopes and all Accessories and Apparatus, Photographic and Photo-Micrographic Apparatus and Outfits.

Spectacles, Eye Glasses, Opera, and Marine Glasses, etc.
Illustrated Price List mailed free to any address. Mention SCIENCE in corresponding with us.



QUEEN & CO. MANUFACTURERS AND IMPORTERS
824 CHESTNUT ST. PHILADELPHIA PENNA.

MAGIC LANTERNS
SCIOPTICONS
STEREOPTICONS
FIRST CLASS
PROJECTING APPARATUS
FOR SCHOOLS COLLEGES
AND PUBLIC ENTERTAINMENTS

COPYRIGHT 1888 SEND FOR CATALOGUE



ZOOLOGY, ANATOMY, PALEONTOLOGY.—Large stock of Vertebrates and Invertebrates.—We arrange and furnish complete collections for educational purposes and exhibitions in any or all departments of Zoology. We have an immense stock of recent shells and fossils, especially from the tertiary period; anatomical preparations; models (made of papier maché) of the human body, divisible, complete, and in separate parts, also separate parts of mammals, very important for the study of anatomy; also microscopical preparations. Linnæan Institution for Natural History, Berlin, Germany. Our Agent in the U. S., Mr. HERMAN ROLLÉ, 33 Ave. A, New York City, will send specimen catalogues free on application.

SCIENCE

SEVENTH YEAR.
VOL. XIII. No. 313.

NEW YORK, FEBRUARY 1, 1889.

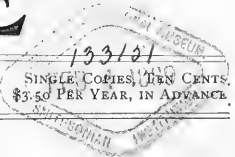

STATEMENT OF

The Mutual Life Insurance Co. of New York,

RICHARD A. McCURDY, PRESIDENT.

FOR THE YEAR ENDING DECEMBER 31st, 1888.

Total Assets - - - \$126,082,153.56.

Increase in Assets	\$7,275,301 68
Surplus at four per cent	7,940,063 63
Increase in Surplus	1,645,622 11
Policies in force	158,369
Increase during year	17,426
Policies written	32,606
Increase during year	10,301
Risks assumed	103,214,261 32
Increase during year	33,756,792 95
Risks in force	482,125,184 36
Increase during year	54,490,251 85
Receipts from all sources	26,215,932 52
Increase during year	3,096,010 06
Paid Policy-Holders	14,727,550 22

THE ASSETS ARE INVESTED AS FOLLOWS :

Bonds and Mortgages	\$49,617,874 02
United States and other securities	48,616,704 14
Real Estate and Loans on collateral	21,786,125 34
Cash in Banks and Trust Companies at interest	2,813,277 60
Interest accrued, Premiums deferred and in transit, Etc.	3,248,172 46
	\$126,082,153 56

I have carefully examined the foregoing statement and find the same to be correct.

A. N. WATERHOUSE, Auditor.

FROM THE SURPLUS ABOVE STATED A DIVIDEND WILL BE APPORTIONED AS USUAL.

Year.	Risks Assumed.	Risks Outstanding.	Surplus.
1884.....	\$34,681,420.....	\$351,789,285.....	\$4,743,771
1885.....	46,507,139.....	368,981,441.....	5,012,634
1886.....	56,832,719.....	393,809,203.....	5,043,568
1887.....	69,457,468.....	427,628,933.....	6,294,412
1888.....	103,214,261.....	482,125,184.....	7,940,063

NEW YORK, January 23, 1889.

BOARD OF TRUSTEES.

Samuel E. Sproulls,
Lucius Robinson,
Samuel D. Babcock,
George S. Coe,
Richard A. McCurdy,
James C. Holden,
Herman C. von Post,
Alexander H. Rice,
F. Ratchford Starr.

Lewis May,
Oliver Harriman,
Henry W. Smith,
Robert Olyphant,
George F. Baker,
Jos. Thompson,
Dudley Olcott,
Frederic Cromwell,
Julien T. Davies.

Robert Sewell,
S. Van Rensselaer Cruger,
Charles R. Henderson,
George Bliss,
Rufus W. Peckham,
J. Hobart Herrick,
Wm. P. Dixon,
Robert A. Grannis,
Nicholas C. Miller,

Henry H. Rogers,
Jno. W. Auchincloss,
Theodore Morford,
William Babcock,
Preston B. Plumb,
William D. Washburn,
Stuyvesant Fish,
Augustus D. Julliard,
Charles E. Miller.

ROBERT A. GRANNIS, - - - Vice-President.
WILLIAM J. EASTON, - - - Secretary.

ISAAC F. LLOYD, - - - 2d Vice-President.
FREDERIC SCHROEDER, - - - Assistant Secretary.

WILLIAM H. D. BARTLETT, LL.D., Actuary. ERASTUS C. BENEDICT, Assistant Actuary.
FREDERIC CROMWELL, Treasurer. JOHN A. FONDA, Assistant Treasurer.
WM. W. RICHARDS, Comptroller. WM. P. SANDS, Cashier.
GUSTAVUS S. WINSTON, M.D., WALTER R. GILLETTE, M.D., E. J. MARSH, M.D., Medical Directors.
WM. G. DAVIES, Solicitor.

GUARANTY INVESTMENT COMPANY

CAPITAL \$250,000.

Offices: Atchison, Kan. 191 Broadway, New York, 222 Walnut St., Phila.

Hon. ALBERT H. HORTON (Chief Justice, Kansas Supreme Court), Topeka, Kan., Pres't.

7% Guaranteed Farm Mortgages 7%

The Guaranty Investment Company makes loans upon fertile farms in the choicest portions of Kansas and Nebraska and has adopted the policy of sending a Committee of its Investors each year to examine its loans and methods of business.

The Committee this year consisted of PROF. A. H. BERLIN, Principal of the High School Montrose, Pa., and MAJ. THEODORE L. POOLE, Ex-U. S. Pension Agent, Syracuse, N. Y. Both of these gentlemen are persons of the highest character and have the confidence of the Communities in which they reside.

The Committee has recently returned and has made a very interesting Report upon the general development of Kansas and Nebraska as well as the business of the Company. The Company will be glad to send this Report to any address.

The following names are taken from the long list of Investors in our Mortgages:

(See if Some Friend of Yours is not in the List.)

William A. Cauldwell, 59 Liberty St., N.Y.
Palmer Cox, 638 Broadway, N.Y.
Rev. Jos. H. Elyance, D.D., 11 Livingston Place, N.Y.
Rev. Brady E. Backus, D.D., 560 West 28th St., N.Y.
Rev. R. M. Somerville, 126 West 45th St., N.Y.
Dr. Robert A. Murray, 235 West 23d St., N.Y.
Dr. James P. Tuttle, 120 West 41st St., N.Y.
H. Edwards Rowland, 248 Fulton St., N.Y.
Irving H. Tift, Esq., 271 Broadway, N.Y.
Prof. D. G. Eaton, 55 Pineapple St., Brooklyn, N.Y.
Dr. F. P. Thwing, 150 St. Marks Ave., Brooklyn, N.Y.
Dr. C. C. Miles, Greenport, N.Y.
John V. N. Bergen, Port Jefferson, N.Y.
Benj. W. Sulwell, Yonkers, N.Y.

R. C. Coleman, Goshen, N.Y.
Mrs. Samuel Carlisle, Newburg, N.Y.
Dr. C. C. Bartholomew, Ogdensburg, N.Y.
Rev. Nelson Millard, D.D., Rochester, N.Y.
Rev. Horace G. Hinsdale, D.D., Princeton, N.J.
Dr. Charles M. Howe, Passaic, N.J.
George A. Skinner, 5 Railroad Place, Newark, N.J.
Dr. Edwin M. Howe, 85 Halsey St., Newark, N.J.
Dr. H. C. Buckingham, Clayton, N.J.
Dr. Martin Cole, Jr., Hainesville, N.J.
Mortgage Trust Co. of Pa., Philadelphia, Pa.
Miss Mary Miller, 1230 Spruce St., Philadelphia, Pa.
Henry D. Biddle, 312½ Walnut St., Philadelphia, Pa.

Dr. Calvin C. Halsey, Montrose, Pa.
Rev. William Baldwin, Great Bend, Pa.
Gen. William Lilly, Mauch Chunk, Pa.
Second Nat. Bank, Mauch Chunk, Pa.
Enos E. Thatcher, West Chester, Pa.
Mrs. Townsend Poore, Scranton, Pa.
Rev. Burdett Hart, D.D., New Haven, Conn.
Dr. Frank H. Wheeler, New Haven, Conn.
Charles R. Christy, Stamford, Conn.
Mrs. Catharine F. Butler, Woodmont, Conn.
Miss Jessie Henderson, Lenox, Mass.
Dr. M. J. Halloran, Worcester, Mass.
Albert Walker, Bennington, Vt.

Address for Report and Monthly Bulletin

HENRY A. RILEY, General Eastern Manager, 191 Broadway, N.Y.

A Useful and Handsome Present.

Prices Reduced for the Holidays.

The *Hulin* Fountain Pen

Warranted 14 karat gold and to give perfect satisfaction—is pronounced by hundreds of pleased customers to be the best fountain pen in the market because it is always ready. Writes freely and never gets out of order.

Sent by mail prepaid for \$1.50, \$2.00 and \$2.50 each, according to size selected.

These are special prices for the holidays, and this offer should be availed of by all who write.

JOHN S. HULIN,
Mfg Stationer and Steam Printer.

Wedding Invitations and Visiting
Cards Engraved to Order.
369 BROADWAY, N. Y.
Near Franklin Street.

The Largest, Handsomest, and Most Complete
Account-Book Manufactory and Printing Establish-
ment for Fine Commercial Work in New
York City.

A NEW MAGAZINE—THE SWISS

Devoted to spreading a love of
nature among the people. Edited
by HIRSHAN H. BALLARD, President of the American Assoc-
iation, and succeeding St. Nicholas as the official maga-
zine of that body. \$1.50 a year. Sample copy 10 cents, or 25
cents for trial subscription for 3 months.
N. D. C. HODGES, PUBLISHER,
Mention this paper. 47 Lafayette Place, New York.

KNABE

PIANOFORTES.

UNEQUALLED IN

Tone, Touch, Workmanship and Durability.

WILLIAM KNABE & CO.

NEW YORK: No. 112 Fifth Av., above 16th St.
BALTIMORE: Nos. 22 and 24 E. Baltimore St.
WASHINGTON: No. 817 Market Space, Penn. Av., near 9th St.

Old and Rare Books.

JAHRESBERICHT DER CHEMIE [Fittica] 1877-
1885 inclusive; 12 volumes in cloth, half goat. For sale
at cost. Also Register zu den Berichten für 1867 bis 1876.
Address Scientific Library, Smith College, Northampton,
Massachusetts.

A. S. CLARK, Bookseller,

34 PARK ROW, NEW YORK CITY.

A Gleaner in the By-ways of Literature. Results of Gleaning
found in Catalogues issued from time to time.

CATALOGUE NO. 27 NOW READY.

BACK NUMBERS and complete sets of leading Maga-
zines. Rates low. AM. MAG. EXCHANGE,
Schoharie, N.Y.

FOR SALE.—Set Popular Science Monthly
with Supplements. H. Williams,
39 Macdougall St., N.Y.

H. WILLIAMS,

Dealer in Old Magazines, Reviews, &c. Scientific
periodicals a specialty. 39 Macdougall St., N.Y.

Readers of Science

Corresponding with or visiting Adver-
tisers will confer a great favor by mention-
ing the paper.

FOOD ADULTERATION

And its Detection. With photomicrographic plates and
a bibliographical appendix. By J. P. Battershall. 328
pages, 8vo, cloth. Price, \$3.50. Circulars and Catalogues
on application. E. & F. N. SPON,

12 Corlandt St., New York.

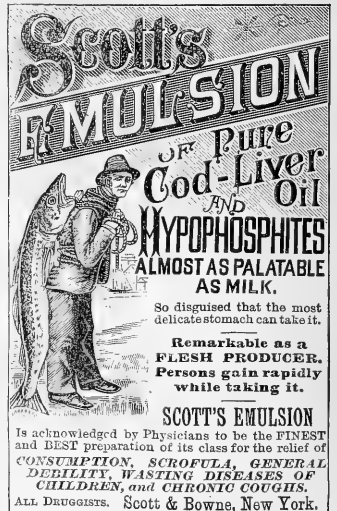

Scott's
EMULSION
OF Pure
Cod-Liver Oil
AND
HYPOPHOSPHITES
ALMOST AS PALATABLE
AS MILK.
So disguised that the most
delicate stomach can take it.
Remarkable as a
FLESH PRODUCER.
Persons gain rapidly
while taking it.
SCOTT'S EMULSION.
Is acknowledged by Physicians to be the FINEST
and BEST preparation of its class for the relief of
**CONSUMPTION, SCROFUL, GENERAL
DEBILITY, WASTING DISEASES OF
CHILDREN, and CHRONIC COUGHS.**
ALL DRUGGISTS. Scott & Bowne, New York.

SCIENCE

FRIDAY, FEBRUARY 1, 1889.

OIL-BURNING STEAM-ENGINES.

THE engine known as "The Shipman," an illustration of which accompanies this article, is an automatic steam-engine and boiler complete, using kerosene-oil of a low test for fuel, and is designed for all users of a moderate amount of power. Its essential points are, that it is so thoroughly automatic in fuel, water-supply, and speed, that, when steam has been raised, little if any further atten-

tion is required beyond that of opening or closing the throttle-valve when the engine is started or stopped. The fire is formed by a mixture in proper proportions of steam and oil. This is fed through one or more atomizers, according to the size of the boiler. A supply of steam from the boiler passing through these atomizers carries with it into the fire-box, in a fine spray, just the amount of oil necessary to generate steam for the work being done by the engine. As the oil enters the fire-box, it is ignited by a torch, and the combustion is so perfect that there is little or no smoke; so the full value of the heating qualities of the oil is obtained.

If the engine is stopped, the fire is entirely put out by the diaphragm; but upon starting again, the fire at once relights itself, the

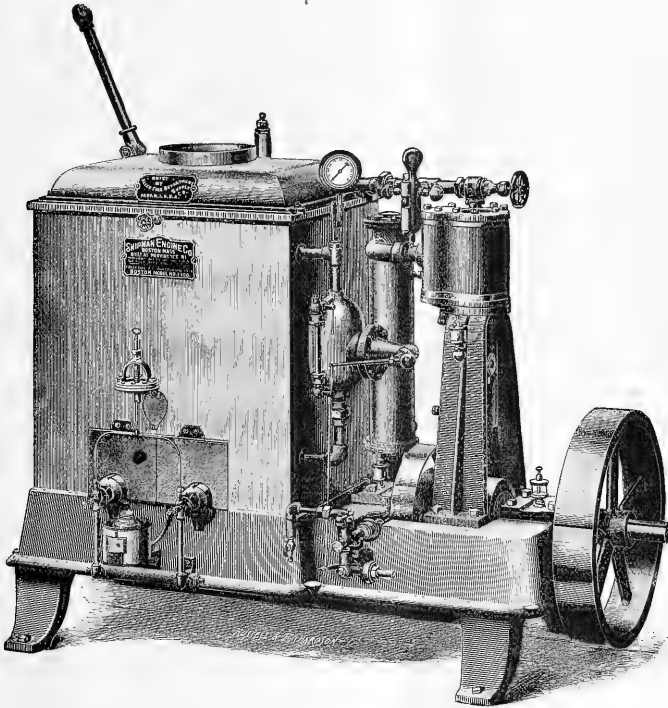

FOUR-HORSE-POWER SHIPMAN ENGINE

tion is required beyond that of opening or closing the throttle-valve when the engine is started or stopped.

In burning the oil, no wicks are used, and there is nothing to gum up or clog. The fire is formed by a mixture in proper proportions of steam and oil. This is fed through one or more atomizers, according to the size of the boiler. A supply of steam from the boiler passing through these atomizers carries with it into the fire-box, in a fine spray, just the amount of oil necessary to generate steam for the work being done by the engine. As the oil enters the fire-box, it is ignited by a torch, and the combustion is so perfect that there is little or no smoke; so the full value of the heating qualities of the oil is obtained.

The amount of steam and oil used by the atomizers is controlled by a perfectly automatic diaphragm-valve, located in the steam-pipe between them and the boiler. Through this diaphragm, the mechanism of which is simple, and to which easy access can

be had, passes the steam on its way to the atomizers; and, as the pressure of the steam in it becomes greater or less than the tension of the spring which governs it, a valve attached to the diaphragm-plate is made to close or open, and thus regulates not only the amount of steam and oil being consumed, but also the pressure in the boiler. In this manner the fire is increased or decreased, according to the load on the engine, and the steam-pressure is kept constant. The height of the pressure to be carried is at the option of the user, and can be varied by him almost instantly.

If the engine is stopped, the fire is entirely put out by the diaphragm; but upon starting again, the fire at once relights itself, the

steam-pressure having been held, in the mean time, by the automatic action of the diaphragm, which will have allowed just enough oil to be burned to make up for the loss of steam by condensation. The supply of oil is stored in a tank placed at any convenient distance from the boiler, and is led to it by ordinary piping. The boiler consists of a hollow oblong back constructed of steel and thoroughly stay-bolted. Into one side of this back are screwed lap-welded wrought-iron tubes one and three-quarters inches in diameter, and thirteen inches in length. These tubes are closed at the outer end by a welded plug. This makes a very compact and quick-steaming boiler, gives large heating surface, and insures safety, it being almost impossible to explode one so that it will do harm. The boilers are tested by a hydraulic pressure of four hundred pounds. As a matter of record, steam can be raised on a four-horse-power boiler, from cold water to one hundred pounds pressure, in ten or twelve minutes.

The water-supply is by a plunger feed-pump, run direct from the engine-shaft, and is kept at a uniform level in the boiler by means of a float connected to a valve in the suction of pump. This float is in a chamber which is connected by piping to the top and bottom of the boiler, and rises or falls with the water. The movement is conveyed by levers to the valve in the pump, which it opens or closes as the water-level changes.

The engine is well built, and of the best material. The piston is solid, and has sectional packing-rings, each section overlapping the other, and being set out by independent springs. This, of course, makes a very tight and true-wearing ring.

The valve is of the piston type, and perfectly balanced.

The governor is an automatic cut-off, working direct from the shaft to the valve; and the speed is very finely regulated, no matter

The engines and boilers are now built on one or separate bases, of one, two, four, six, and eight horse-power, and the company have in process of construction compound and triple expansion engines of various sizes. For further information, address the Shipman Engine Company, 92 Pearl Street, Boston, Mass.

WATER FILTRATION AND AERATION.

THE rapid growth of the mill industries, and of the arts and manufactures in general throughout the country, bring more than ever prominently to the front the important questions of the purity of the water-supply, and the necessity of taking immediate and active measures to secure this greatly to be desired quality. Particularly is this the case in the southern section of the country, toward

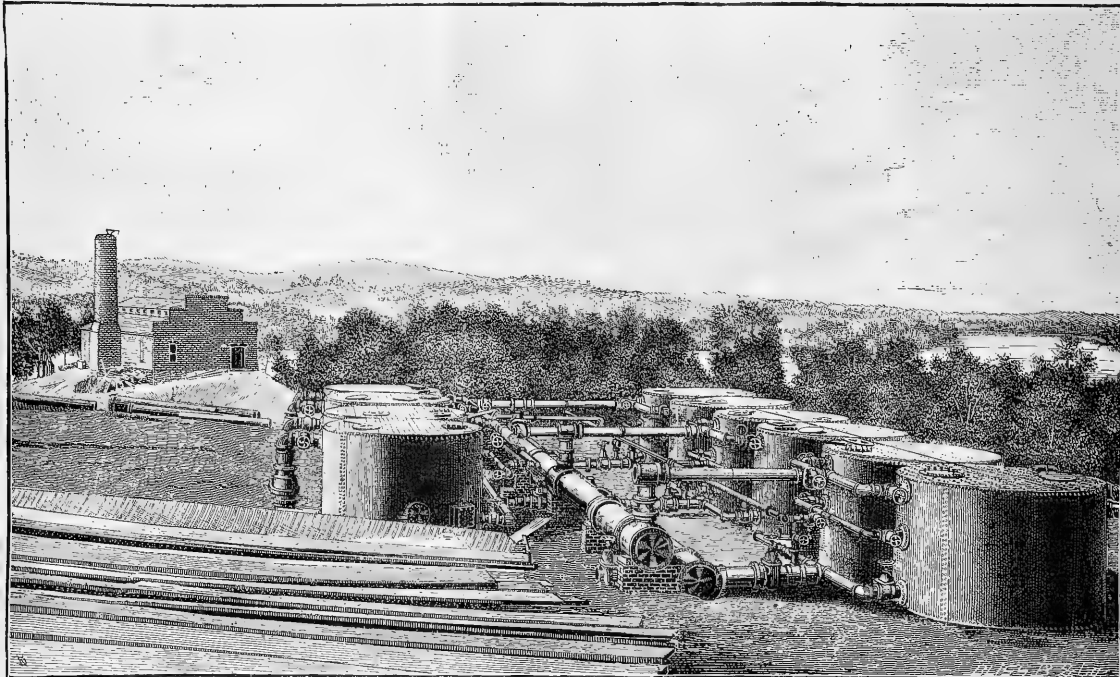

NATIONAL FILTER PLANT AT CHATTANOOGA, TENN.

what the load. The shaft is of cast steel, very large, and having extra long bearings in babbitted boxes.

All wearing parts are of extra size, and adjusted for the taking-up of lost motion. Lubrication of the cylinder is by a sight-feed; and the slides and shaft-boxes, by the ordinary oil-cup. Oiling of the crank-pin is effected by a centrifugal oiler attached to the crank-disk.

From the above it can be seen that when steam has been raised, and a sufficient quantity of oil and water supplied, the engine requires no further attention.

The question is asked, How are the fires operated when there is only cold water in the boiler? For this purpose a hand air-pump, attached to the boiler, is provided. A few strokes of this pump will start the fires, and it is only necessary to pump slowly for seven or eight minutes to raise enough steam to keep them going. As soon as steam is made, all work with the air-pump ceases, and, as before stated, one hundred pounds can be raised in from ten to twelve minutes. As regards the other advantages of "The Shipman," it can be said that it is compact, light, and durable, and entirely dispenses with the services of a skilled engineer.

which the attention of capitalists throughout the world is being more and more attracted. The more important features of health and cleanliness render it an imperative duty to prepare for the rapidly increasing population of our cities by taking judicious measures to secure to every community that system which, having simplicity and durability to recommend it, will, while being economical, insure a sufficient supply of pure water for individual use as well as for the factories and mills. Our country is blessed with a plentiful water-supply in almost every section, and the very fact of the abundance of this supply necessitates the precautions above referred to; as so large an amount of matter is carried in suspension in most of our large rivers, that some system of filtration must be resorted to. Some of the features that tend toward the perfecting of apparatus for this purpose are the ability to maintain the necessary "head or pressure," simplicity of construction, durability, quickness and thoroughness in cleansing, economy in water to accomplish this cleansing, cheapness, strength to withstand any desired pressure, and capacity to supply the maximum amount of clear water required for the purpose in view. The National Water

Purifying Company of New York have in their apparatus combined many, if not all, of these requirements; and an extensive plant installed by them at Chattanooga, Tenn., gives conclusive proof that scientific principles have entered into the construction of the plant, which seems to have well stood the crucial test of actual practice. The rapidity and thoroughness with which these filters can be cleaned, and the small expenditure of water required, are qualities in which this company excels, as they seem to have effectually solved the vexed question of surface washing. It has been found, from long experience, that most of the impurities taken from water, in the course of twenty-four hours lodge in the upper

in the boiler, necessitates a periodical stopping for its removal, ceases to be troublesome. It has been demonstrated beyond question that the thorough purification of drinking-water can be accomplished by combining aeration, precipitation, and filtration; and it is also reasonably claimed that the thorough aeration of water under pressure has the effect of destroying bacteria and plant-life that would be injurious to health. The aeration is accomplished by means of an air-compressor, whereby air is forced into the water under high pressure, thus producing a chemical action, which destroys the disease germs in the water, making it clear and sparkling. The process employed to attain this end by

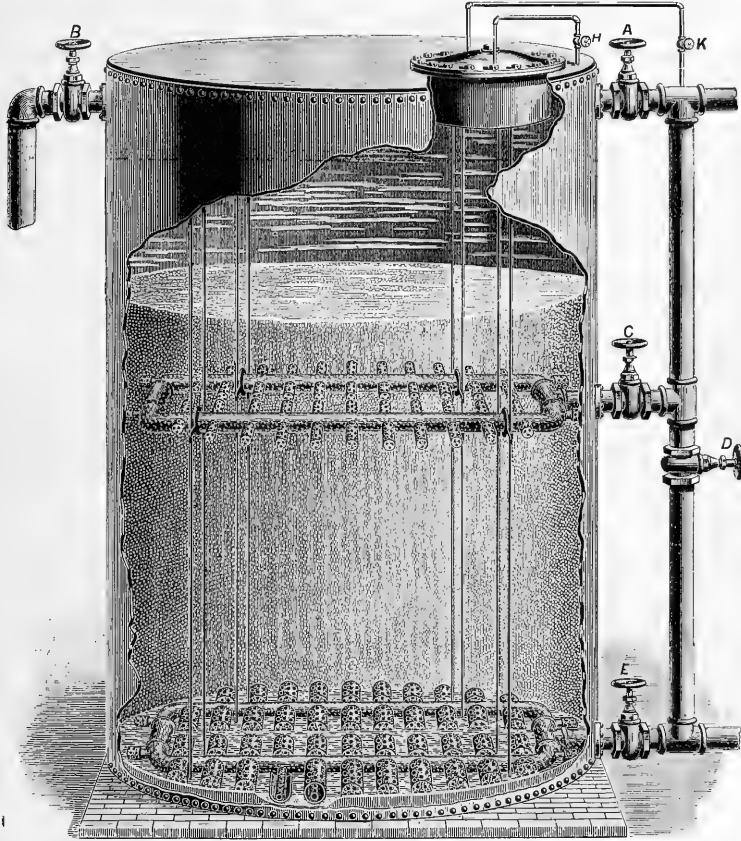

SECTIONAL VIEW OF NATIONAL FILTER (250 GALLONS PER MINUTE).

six to ten inches of the sand-bed through which the water must pass before it leaves the filters, and that in their large machines, having a capacity of 250 gallons per minute of pure filtered water, this surface washing can be accomplished in four minutes, after which a reverse current up through the sand-bed breaks it up completely, and throws out all the finer particles of dirt. As the only labor required to accomplish this cleansing is the mere opening and closing of valves, the reverse current doing all the work, some idea of the extreme simplicity of the filter can be formed. By creating a feed of water free from those impurities which induce the formation of "scale" in boilers, a great economy of "fuel" is effected; the salts and other deleterious substances being deposited in the sand-bed of the filter, instead of passing into the boiler and shortening its period of usefulness by hastening corrosion, while the sediment that induces foaming, and which, gradually settling

the National Water Purifying Company is simple and inexpensive, and by it the amount of air forced into the water can be regulated to the exact requirements of the case. As a result, all odor in the mains, and vegetable growth, such as algæ, in the reservoirs, are prevented.

THE CULTIVATION AND UTILIZATION OF RAMIE IN THE UNITED STATES OF AMERICA.

IN his recent report on the Brussels Exhibition, Mr. Joseph Zervas draws attention to the importance of the cultivation of ramie. During the last thirty years, he says, numerous experiments have been made with a view to finding new plants yielding textile fibres. One of the most promising among these is the ramie, which is obtained from two plants, — *Bohmeria nivea*, yield-

ng white ramie; and *Bohmeria utilis s. tenacissima*, yielding green ramie. The fibre, which is also called "rhea" and "China grass," has been imported in considerable quantities into Europe, and extensive experiments have been carried on in regard to its utility.

Ramie is a perennial plant, the bark of which gives a textile fibre superior in tenacity and resistance to that of flax and hemp, while at the same time its length, fineness, clear white tint, and lustrous brilliancy, give it a great resemblance to silk. The amount of textile material obtained from a certain quantity of this plant is considerably larger than that obtained from an equal quantity of either flax or hemp.

Although in some respects inferior to silk, it can be used as an imitation of it; while it will undoubtedly supersede hemp, flax, and harl. Like cotton, it will have its centres of manufacture, and the peoples of the earth will be interested in the progress made in its use. The beauty of its products, the fineness and durability of tissue, more especially its clear tint, make it suitable to take the place of linen goods; and its easy manufacture will insure its rapidly gaining supremacy over other textile products.

The cultivation of ramie was introduced into Mexico by Mr. Benito Roelz de Santo Comspan; into the United States, by Mr. J. Bruckner of New Orleans; and into Belgium, by the Josephites of Melle, near Ghent. In Germany and Bohemia the first experiments were made with white ramie, as it was thought to be more advantageous, owing to its readier acclimatization to countries less warm than China or Japan, from which it had before been imported; but so far its cultivation, for reasons which will be shown later, has made but little progress. Recently machinery has been invented which makes its manufacture more successful; and since that time this industry has made rapid progress. Governments of several European nations are taking an active interest in the cultivation of this plant.

The utilization of ramie fibres is of great antiquity. Their virtues are recorded in the poems of Ramagana and of Kalidasa, who sing the praises of the stuffs made from ramie, which seems to have been grown at that time in the Himalaya Mountains. Pallas contends that the Chinese frequently deceived the Russians by selling them stuffs manufactured from ramie-thread (the wool alone being of real silk) as real Damask silk. We find in the annals of Nestor, of the year 904, that the sails of the Volga vessels were nearly all manufactured from ramie fibre.

Various kinds of nettles, or ramie, were cultivated in Russia, Siberia, Kamtchatka, and Japan. Dr. Boyle says that in 1810 the first tests of Sumatra ramie were made in India. In 1851 experiments were made in the spinneries of Leeds, which proved very encouraging. In 1868 the price of the raw fibre was £20 per ton at Calcutta, and £40 at London.

Although the cultivation and industry of ramie are still principally limited to the countries to which its growth is indigenous, the attention of every agricultural country, and of every textile manufacturer, should be drawn to its value with a view of determining as to the benefits to be derived from its introduction.

No country is better adapted for the introduction and cultivation of ramie than the United States, which, owing to its extensive territory, affords all possible conditions for cultivation as regards either soil or climate, and where the power of capital conduces so favorably to the development of enterprises.

It is not difficult to imagine the importance which this new industry may gain in the United States, when we consider that in 1887 the total importation of textile material (flax, hemp, jute, and other vegetable substances) from foreign countries into the United States amounted to about one hundred and twenty-three thousand tons, representing a money value of fourteen million dollars.

The exportation of vegetable fibres of every kind to the United States from the consular district of Brussels (Belgium) amounted, in 1880, to \$54,411.88; in 1881, \$58,307.68; in 1882, \$34,065.78; in 1883, \$41,989.20; in 1884, \$37,041.14; in 1885, \$51,004.56; in 1886, \$62,587.30; in 1887, \$39,245.92. The falling-off in the exportation of last year is due to the probable change in the tariff.

It has been inferred above, that, as a result of experiments made towards acclimatizing ramie in foreign countries, there has not been any extraordinary industrial success, although remarkable progress regarding our knowledge of the plant, and the best methods of

treating it, has been made. Even in the utilization of the fibre for spinning purposes, many difficulties were encountered until lately. The obstacles in the way of the cultivation of ramie arose principally from the fact that the plant itself, and the practical utility of it, were unknown; that statements regarding its use had been found erroneous, exaggerated, and untrustworthy.

No knowledge whatever of the soil suitable for its growth and cultivation, nor of the proper climate, was possessed. The culture of an inferior kind of ramie was introduced into northern countries, and its merits were so highly exaggerated that its partial failure prejudiced many of its warmest adherents. This species, the white ramie, is not nearly as good as the green.

Among the different kinds of ramie experimented upon with a view to their introduction into Europe and America, only these two species are accepted as being useful and suitable for acclimatization. The *Bohmeria nivea* (the white ramie), of Chinese origin, belongs to the temperate zone. The under part of its leaves is of a nacreous white color, with green veins, the leaves and stalks being very vigorous. The ripe stalk is of a red-brown blood color. Its fibre is greatly inferior to that of the green ramie, it is rougher to the touch, is not so full, and bears less resistance to tension. The stalks do not grow so high, and they have less tendency to run to seed. The plant also resists the cold better; for, while one has to be protected in severe weather, the other has not, and can be left in winter in a meagre soil. The *Bohmeria tenacissima* (green ramie) comes originally from an equatorial district, Java. Its fibres are very strong, and the plant is more hardy, and more prolific in fibrous textile, than the other.

The average height of the stalk of the green ramie is about five feet and a half to six feet, while that of the white ramie is of considerably less height, being about four feet and a half. In addition to this, the latter plant grows numerous side branches, which renders pruning more difficult. Accordingly, the product of the green ramie is shown to be superior to that of the white ramie.

It would seem, therefore, that it is a mere question of climate, which favors white ramie, though a recent cultivation of green ramie in Italy, in the province of Padua, shows it to have withstood a temperature of -9° C. or 16° F. In Algeria green ramie has been cultivated exclusively for some time.

Ramie can be raised from seed, from suckers, or from layers or pieces of roots. That reproduced by seed-plants requires too much care, and has a greater tendency to run wild. Suckers have various disadvantages: ten per cent die, and the others cannot withstand the cold. The simplest, surest, and most productive mode of reproduction is by pieces of roots, or cuttings of stalks stuck into the ground. This kind is more productive, fuller, is neater and more easily grown, and reaches maturity at an earlier period.

A comparison of the cultivation of the two species in Italy gives the following result as a fair sample of its produce. Ten thousand mother plants on one hectare gave for two cuttings, —

	Dry Stalks, Kilograms.	Pruned Fi- brous Textile, Kilograms.	Harl per 1,000 Kilograms Stalks.	Harl. Per Cent.
White ramie.....	6,000	1,930	172	17
Green ramie.....	8,000	1,600	199	20

The soil in which ramie should be planted should be light, sandy, well manured and cultured, naturally cool and moist. A good underground is indispensable, as the plant throws out its roots to a depth of from twelve to fourteen inches. It may be said, however, that it accommodates itself readily to almost any kind of soil, but the one indicated gives far superior results. If the soil be too rich, the plant thereby acquires a deleterious amount of ligneous material, which lessens the strength of the plant's fibres. The stalk becomes sappy, more difficult to prune, and hence inferior in quality. A too damp or marshy soil is injurious; although it has been experienced in different districts where it is grown, that a thick coat of mud of a sandy nature, the result of an inundation, has proved rather favorable instead of prejudicial in its effect. A

persistent drought gives a thin and sickly crop: therefore it will be found necessary, where the plant is grown under the influence of great heat, to facilitate the vegetation by frequent irrigations, according as the soil is more or less of an absorbing nature. At least two weeks previous to the cutting of the plant, the irrigations ought to be discontinued, to allow the stalks to gather sufficient strength, ripen, and dry sufficiently for use. In order to secure a good crop, and avoid fermentation of the stalk, it is preferable to cut in dry weather. The manner of planting is quite simple. In the soil already prepared, furrows at least three feet apart should be ploughed (similar to those made in planting potatoes). The plants are then placed in the furrows at three inches depth, so that they alternate with those of the next line. Each plant requires a square yard for its development. This space will be occupied by direct shoots or rhizomas from the end of the second year.

In the third year it will be necessary to thin the plants. In order to secure a free circulation of air, the soil should be carefully weeded during the first year of the plant's growth. In the second year it will be found unnecessary, the ramie overgrowing the weed. It is advisable in spring, or after the first cutting, to dig up a little of the soil about the roots. As the plant is perennial, the better the soil is prepared, the better will be the results. Quoting from the analysis of Dr. J. E. Tornidge, the composition of the fibre is as follows:—

Potash	32.37
Soda	16.33
Lime	8.50
Magnesia	5.39
Oxide of iron17
Chloride of iodium	9.13
Phosphorus	9.60
Sulphur	3.11
Carbon	8.90
Alumina and silica	6.60
	100.00

Ramie, like flax and hemp, exhausts the resources of the soil rapidly: therefore careful manuring is necessary. The above analysis may be a guide in selecting the fertilizer. In Europe only two cuttings a year can be depended upon; for, even by the use of liquid manure with irrigation, it has been ascertained that a third crop is extremely sickly and weak, even under the most favorable circumstances. In countries where the climate resembles that of regions to which the plant is indigenous, as many as five crops can be obtained if great care be given to its cultivation. The best time for gathering it is when a red-brown color is visible in the lower part of the stalk.

The stalks should be cut at about four inches from the ground, by a clean incision, to avoid damage. It is then necessary to dry them quickly in the sun; and they should be peeled within at least forty-eight hours, after which time peeling would be difficult.

If stored for winter use, it should be kept in a dry place. In the process of drying, the leaves should be stripped. If used for cattle-feeding, as is often the case, they should be given while still green. This, however, is an expensive proceeding. When the stalks are dried with the leaves remaining on them, they can be easily shaken off at the end of two days. They can be usefully employed in the manufacture of paper, or left on the ground, for which they form a good manure. The produce of the stalk is, as shown, dependent upon the climate and proper treatment. As no statistics have yet been made in countries where its growth is indigenous, it is necessary to make an estimate from the results obtained in countries less favorable to its growth: therefore the estimates are probably too low. In Italy, in the third year, when the plantation reached its definitive state, the produce of one hectare (2,471 acres) of ramie amounted to about 80,000 kilograms (1 kilogram = 2.2 pounds) green stalks, of which one-half is attributable to leaves. The first cutting gave 41,200 kilograms, the second 39,700 kilograms, green stalks, which together makes 80,900 kilograms. Deducting fifty per cent leaves, there remain 40,450 kilograms of green stalks, or 1,600 kilograms harl. Two thousand kilograms of harl have even been obtained, and 1,800 is not an exaggerated average, per hectare.

Labor, manure, rent, pruning-machines, and general expenses are of course to be counted; and, as such expenses would in

America be highly in excess of those in Italy, it could only be by practical trial and experiment that the cost of its cultivation in the United States could be ascertained. The results show, however, that the cultivation is extremely remunerative, and in the United States it would prove still more profitable.

The greatest difficulty yet experienced in the industry is that of properly peeling or decorticating the stalks. With a view of promoting this industry, the Indian Government, in 1870, offered a prize of £4,000 for the best machine manufactured to peel the raw fibre; subsequently a prize of £5,000 was offered in England for the same purpose; and quite recently an exhibition has been decided upon, to be opened on the 25th of September, by the minister of agriculture in Paris, for machines for the purpose of peeling ramie stalks. As in the case of all textile plants, the object is to separate the ligneous part from the herbaceous part; that is to say, the stalks from the bark. The ligneous part is used for manure only. The bark, on the contrary, contains the fibrous matter for the manufacture of harl. Its manufacture is possible in several ways. First, during the first two days after the cutting of the stalk, the viscous liquor which is found between the ligneous part of the stalk and the bark allows it to be peeled with facility. The Chinese and Indians simply employ their forefinger and thumb to peel the bark while in that state. This is of course primitive, and machines based on that principle have always been found unsatisfactory. Second, many inventors proceeded, as in the case of flax and hemp, by a kind of previous maceration called "retting;" but this also has proved unsatisfactory, on account of its speedy putrefaction, hemp being capable of greater saturation than ramie. Third, chemical operation has at all times proved prejudicial to ramie fibre, causing loss of weight and brilliancy of appearance. Fourth, other manufacturers constructed machines with a view to abandoning retting. These are constructed so as to peel the harl, and do the least possible injury to the textile qualities of the plant, and, by working the plant when dried, to completely disaggregate the fibre so as to render it of greater value. When working green, there is apt to be a great loss of fibre, as it is impossible to perfectly peel the stalk. The disaggregation is poor, the fibre leaving the machine in strips, which necessitates its being worked by chemical substances, to obtain the division of the thread: hence a machine working dry, with little loss, is of greater advantage.

Among the machines working green, that of the American, Mr. Berthel, gives a waste of more than one-half of the textile fibres. Requiring a force of two horse-power, it is able to work 150 kilograms (330 pounds) of dry harl per day, the price being \$500 for this machine. The machine built by Felix Roland, a French engineer, is somewhat better; but the waste still amounts to two-fifths of the whole. The machine of three-quarter horse-power works 150 kilograms of dry harl, and costs \$250; that of one horse-power works 200 kilograms (440 pounds) dry harl, and costs \$360. The machine of Messrs. Moermann-Laubuhr, Belgian engineers, which is really an old flax machine, requires a previous maceration of the plant, necessitating thereby inconveniences. It requires four horse-power to work 200 kilograms of harl per day, and its price is \$1,200. Among dry-stalk working machines is one manufactured originally for flax by Arthog, which works 100 kilograms (220 pounds) at two horse-power, and its price is \$800. Until recently (1875), the best machine originally built for flax was manufactured by Cardow & Son, and improved upon by Huet Lagache, for the treating of ramie; but the harl often rolled up around the cylinder, the brown epidermis was often left, and considerable loss ensued. The produce is 200 kilograms for four horse-power, the price being \$2,000. Felix Roland, who was mentioned above, also built a machine for working dry stalk. Little injury, as well as little loss, was experienced by the use of this machine. Of these machines he has three different sizes. No. 1 produces 60 to 70 kilograms (130 to 154 pounds) a day, worked by a man, the price being \$300; No. 2 produces 150 to 160 kilograms (330 to 352 pounds) a day, three-quarter horse-power, the price being \$440; No. 3 produces 200 to 250 kilograms (440 to 560 pounds) a day, one horse-power, price \$600.

Peeling expenses do not exceed three per cent by this system, wages being reckoned at \$1.25 per day. This machine was considered the best, as is shown by the fact of the minister of the

French Navy buying one for the colonies of Guinea, etc. Lately, however, in the Brussels Exhibition, the new stripping and peeling machine of Norbert de Landtsheer from Paris was exhibited, and it is the most simple, complete, and inexpensive machine yet used for the peeling of either dry or green stalks. Peeling is accomplished without crushing, and the threads are free from cuts. The dis-aggregation is perfect, and the machine is free from waste in either dry or green peelings. The daily product is: dry, 100 to 158 kilograms (220 to 330 pounds), a quarter to one horse-power; green, 100 to 200 kilograms (220 to 440 pounds), a quarter to one horse-power, price \$240. A machine run by hand-power produces 75 kilograms (165 pounds), price \$200.¹

On a large scale of cultivation, a corresponding series of machines built by Norbert de Landtsheer will be necessary. With this in view, and the value of these machines being established, there is no longer any doubt as to the success of its introduction into the United States, where the conditions of soil and climate are so favorable.

they birds or fish, have such a form, the larger end being the forward end in their movements. To maintain the shape under varying pressure, there are two air-tight conically shaped compartments, — one at each end of the balloon proper, — into which air or other gas may be forced, as occasion may require, to keep them distended.

The buoyant power it is proposed to make just sufficient to raise the ship; and if, on rising higher, the warmth of the sunlight or other cause should expand the balloon, some of the gas would be removed, and condensed, thus doing away with the clumsy make-shift now in vogue of throwing out ballast.

To start with, the balloon is supposed to be filled with just enough coal-gas to cause it to rise. As the balloon rises, a portion of this gas may be withdrawn and compressed, and another portion may be employed to drive the motor, and some part will escape. To replace this loss of buoyancy, there is a reservoir in the car containing a solidified gas, the composition of which Mr. Boisset still keeps a secret, but the basis of which is ammonia, from which

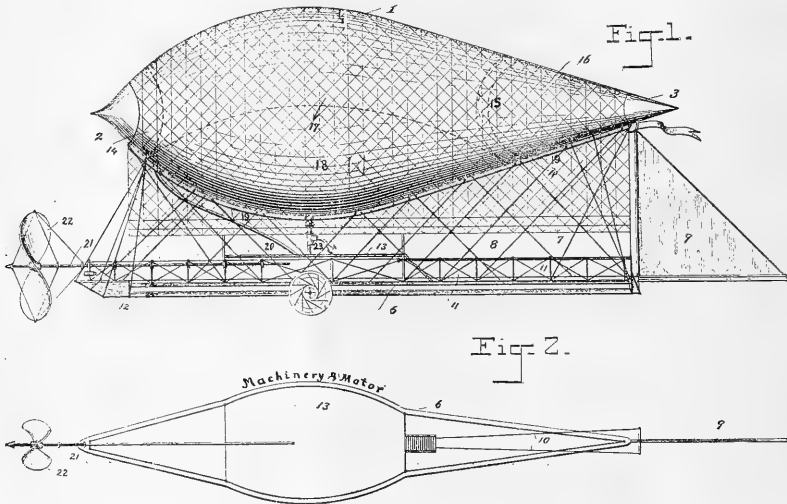

THE AIR-SHIP OF LOUIS BOISSET.

1. Extremity of the inflated part; 2. Front cone; 3. Back cone; 4. Nets; 5. Riggings; 6. Lower parts of the car; 7, 8. Fringe of the net; 9. Rudder or guiding sail; 10. Passengers' cabin; 11. Safety-rail; 12. Front extremities of the car; 13. Machinery and motor-room; 14. Front air-tight compartment; 15. Back air-tight compartment; 16. Large back air-tight compartment; 17. Centre of gravity; 18. Large central compartments for ammoniacal gas; 19. Metallic bar (very light); 20. Gas-pipes for the motor; 21. Shaft of tractive screw; 22. Tractive screw; 23. Throttle-valve for ammoniacal gas; 24. Wheel with air-sails.

It is not within the scope, nor is it the intention, of this article, to advise agriculturists to proceed to develop this industry on the strength of the information and statements contained in this report, but rather to draw the attention of the United States to the feasibility of its introduction into the country.

AN AIR-SHIP.

MR. LOUIS BOISSET, a retired officer of the French army, is now in this country, perfecting an air-ship, an invention of his, and seeking the protection of the United States patent laws.

Mr. Boisset has had some experience in recent years with the air-ships experimented upon by the French war department, the more or less successful voyages of which over the suburbs of Paris were recorded in *Science* in 1884. One trouble with these older forms Mr. Boisset believes to have been due to their symmetrical form, and he seeks to make the equilibrium of his balloon when in motion more stable by giving it, as shown in the figure, an ovoid form, following in this the dictum of Mr. Dupuis de Lome, — that in general, organisms destined for motion in water or air, be

¹ At aforesaid September Exhibition at Paris the decorticating machine of De Landtsheer was recognized to be the best.

a fresh supply of gas can at will be obtained, and introduced into the lower compartment (18) of the balloon.

Mr. Boisset believes that he has made improvements over any thing that has gone before, in the shape and rigging of the ship, in the gas-motor, and in the method of compensation by which the equilibrium of the ship may be maintained. Further, the dividing of the balloon into air-tight compartments is a novel feature, and allows of replacing the consumed coal-gas by the ammoniacal gas, whatever its composition may be, without mixing the two.

Mr. Boisset estimates that a vessel of his construction, capable of crossing the Atlantic, should have a gas-chamber (the balloon proper) 62 metres in length, and with a maximum diameter of 20.33 metres. The height from the top of the balloon to the flooring of the basket would measure 31 metres; and the length from the end of the propeller to the end of the rudder-sail, 82 metres. The weight of the ship, its provisions, crew of ten men, and passengers, the inventor would place at 6,000 kilograms.

AMONG the features of the issue of *Light, Heat, and Power* for Jan. 19, are four photographic plates, illustrating the recent gas-holder explosions at the works of the Citizens' Gaslight Company, Brooklyn, N.Y.

ELECTRICAL NEWS.

Hertz's Researches on Electrical Oscillations.

In reading Faraday's "Experimental Researches on Electricity," one finds many experiments described in which that philosopher attempted to show that some relation must exist between natural phenomena which had been considered as having no connection with one another. He tried to prove that gravitation could produce magnetic or electrical effects; and although he failed, yet at

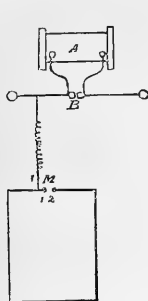

FIG. 1.

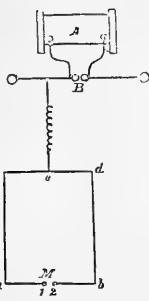

FIG. 2.

the end of the research he expressed his belief that some connection existed, and would some day be discovered. But he did find that a magnetic field had an effect upon polarized light passing through it, and this discovery has been developed until Maxwell advanced the hypothesis that electrical vibrations may be propagated through space according to the same laws that govern the propagation of light, and with the same velocity; and now the theory of Maxwell has been experimentally verified by Hertz. The evidence in favor of Maxwell's theory, before Hertz published his work, lay principally in the facts that the equations of propagation of an electro-magnetic disturbance were practically those which have been deduced for light, and which have explained a number of the phenomena that take place. The velocity of such a disturbance is equal to a constant which can be determined electrically, and which agrees very well with the observed velocity of light; while a relation between the specific inductive capacity, determined electrically, and the index of refraction of a substance, agrees fairly well with that deduced from Maxwell's theory. Hertz has added to this evidence a proof—indirect, but fairly conclusive—that the "electrical displacements" in a dielectric, on which rests much of Maxwell's theory, really exist; that actual electro-magnetic waves are reflected and interfere with one another; and that the velocity of such waves is about what is calculated. We will describe Hertz's experiments as clearly and briefly as possible, referring those who desire a detailed description to Hertz's and De Funzelmann's papers.

In the first place, it was necessary to produce electrical oscillations of a very small period. Roughly, the period of a light-wave is 10^{-16} of a second, and we know of no way of producing electrical oscillations, on a conductor of finite size, of any thing near so rapid a period. When Hertz took the matter up, the most rapid oscillations that had been experimented upon were those caused by the discharge of a Leyden jar through a resistance, the period being about 10^{-6} of a second. Theoretically a much shorter period would be obtained with conducting-wires forming an open circuit, the ends having small knobs on them; and this is the form Hertz first experimented on, his object being to discover whether measurable oscillations were really produced. The period in this case should be some hundred millionths of a second, — 10^{-8} as compared with 10^{-16} for light. The general arrangement of the apparatus is shown in Fig. 1. Here *A* is a large induction-coil, with the wires *B* fastened to the terminals of the secondary circuit. The

coil Hertz used was a large one, 52 centimetres long by 20 centimetres in diameter, and it was run by six large Bunsen cells.

When the coil is working, there are sparks between the knobs *B*; and, when one of these sparks passes, we have the case of the discharge of conducting-wires forming an open circuit; and this will cause rapid oscillations along the wires, which will diminish in amplitude until they are re-enforced by another discharge. To observe these disturbances, Hertz arranged a circuit, shown in Fig. 1 at *M*. This was simply an open circuit of wire, with two adjustable knobs, 1 and 2. On connecting this "micrometer" circuit to one of the wires *B*, the connection being as shown in Fig. 1, sparks, sometimes several millimetres long, passed between 1 and 2.

The reason of this is, that the rapid and violent oscillations on *B* are transmitted to the knob 1, sometimes causing a high and sometimes a low potential at that point. Now, if it takes a finite time for this disturbance to travel around the circuit *M*, then there will be for a short time a considerable difference of potential between 1 and 2, and this causes the spark. With the connection to *M* made as in Fig. 2, the distances of *e* from 1 and 2 being equal, then the disturbance reaches these points at the same moment, and there is no difference of potential between them, and therefore no spark. This is what Hertz actually finds.

Some of the facts that Hertz obtained were these: In the first place, the effect in the micrometer circuit depends on the shape of the terminals *B* and on the nature of the spark: the material and size of the wire of the micrometer circuit has very little influence on the spark. If, when the contact is at *e* (Fig. 2), a conductor be joined to one of the knobs 1 or 2, then the spark re-appears.

This last, Hertz thinks, shows that the phenomenon cannot be due to single waves in the directions *ca* and *db* respectively, but must be due to a series of oscillations set up in the micrometer circuit; and the addition of a conductor to one of the knobs changes the period of vibration of that branch, the periods being determined by the product of the coefficients of self-induction into the capacities of the branches. The fact that the material of which the circuit is made has no effect on the spark, tends to show the same thing; namely, that the phenomena in the micrometer circuit are dependent upon self-inductions and capacities, that is, upon time-constants.

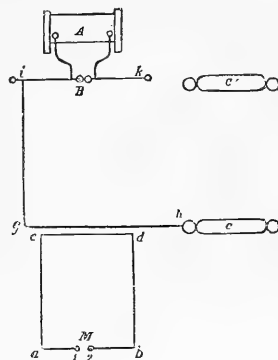

FIG. 3.

To further prove the oscillatory character of the discharge, Hertz used the arrangement of Fig. 3. Here the micrometer circuit was placed with one of its sides parallel to the wire *gh*, which was connected to one of the discharge wires *B*. The sparks at *M* were very feeble until a conductor, *C*, was attached to the free end, *h*, of the wire, when they increased to two millimetres. No effect was produced when *C* was attached at *g*. When the knobs at *B* were so far apart that no sparking took place, the sparks at *M* also disappeared, which showed that they were due to the sudden discharges, not to the charging current. While *C* was attached to *h*,

¹ Hertz's original papers are in Wiedemann's *Annalen*, 1888. Mr. G. W. de Funzelmann has given an excellent *résumé* of Hertz's work in the *London Electrician*, Nos. 539, 545, 547, 548.

and the knobs at M drawn so far apart that the sparks only passed singly, then if a similar conductor, C' , be brought up to b , a stream of sparks was immediately observed. This action of C' could only be explained by supposing the current in gh was oscillatory.

The reason that a powerful induction-coil gives rise to oscillatory motion is, that, first, it charges the terminals C and C' to a high potential; second, it produces a-spark in the intervening circuit; and, third, as soon as the discharge begins, the resistance of the air-space is so much reduced as to allow of oscillatory motion being set up. If the terminal conductors are of very large capacity (for example, if the terminals are in connection with a battery), the current of discharge may indefinitely reduce the resistance of the air-space; but, when the terminal conductors are of small capacity, this must be done by a separate discharge, and therefore, under the conditions of Hertz's experiments, an induction-coil was absolutely essential for the production of oscillations.

Hertz slightly modified the form of apparatus used to that shown in Fig. 4, where the conductors C and C' were in the same straight line, three metres apart, with the discharger B at the centre. With this arrangement, sparks were obtained in the micrometer circuit when its distance from BC' was one and a half metres. Hertz replaced the micrometer circuit shown in Fig. 4 by another, which

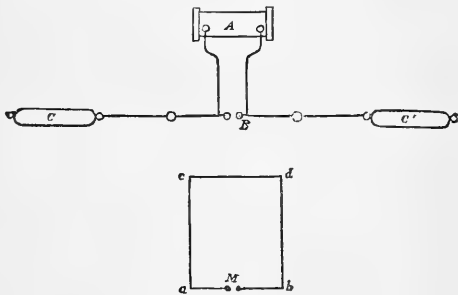

FIG. 4.

consisted of two wires parallel with BC' , with knobs at their ends, there being a micrometer, M , at the middle. Sparks were obtained at the micrometer, as with the other form of circuit. When the knobs at B were drawn so far apart that there was no spark between them, there was still a spark at M due to the electrostatic effect of charging C and C' . By bridging across M with a damp thread, this effect was got rid of; but, when there were sparks at B , there were sparks at M , even with the thread. So the thread was sufficient to afford a passage to the comparatively slow alternations of the coil-discharge, but was not sufficient to provide a passage for the immeasurably more rapid alternations of the oscillatory current.

If there really are oscillations of the nature of a regular vibration, then an oscillatory current of a definite period would exert a much greater inductive effect upon one of equal period than upon one differing from it; that is, we ought to get resonance phenomena from currents, as from sound-vibrations. If two circuits are taken having as nearly as possible equal periods of vibration, the effect of one on the other will be diminished by altering either the capacity or coefficient of self-induction of one of them, as a change in either of these would alter the period of vibration of the circuit.

(To be continued.)

ANOTHER ELECTRIC ROAD AT ATLANTIC CITY, N.J.—We take great pleasure in announcing in this issue of our paper a most important indorsement of the electric system of street-railway propulsion. This indorsement comes from the Pennsylvania Railway Company, who have during this last week, through the general managers of that company, closed a most important contract with the Sprague Electric Railway and Motor Company for the complete equipment of their system of electric street-railways at Atlantic

City, N.J. Before awarding this contract for the equipment of this road, the Pennsylvania Railroad appointed a committee who should have charge of making a most minute and careful investigation of the merits of all the different systems of street-railway propulsion, both electric and cable, now in use. The committee in charge of the investigation were composed of mechanical and electrical experts of the highest class, and of wide reputation. The period of investigation extended over five months, and during this time the committee visited all the principal electric railways and cable roads which are in operation in this country, and carefully examined the operation of each. The Sprague Company are certainly to be congratulated upon securing this contract.

WEST END ELECTRIC ROAD AT BOSTON.—The West End Electric Railway at Boston is running very successfully, and carrying a large number of passengers each day between Park Square (one terminus of the road) and Brighton (the other terminus of the road). The cars run fast, and are under quick and perfect control. The residents in Brookline who use the cars regularly in coming into Boston and returning are enthusiastic over the time saved over the ordinary horse-car. The change of the overhead to the underground system is made very quickly, and without stop, so that no delay is experienced at this point. The car-drivers, or "motoneers," as some Bostonians persist in calling them, are not expert electricians, but simply street-car drivers, who have been detailed to operate the electric cars, and who have learned their necessary duties very quickly. All of these old drivers are enthusiastic over the ease with which an electric car can be driven, and are well pleased with their new position. On the 20th of January a very heavy snow-storm reached the city, and covered the tracks of the railway to the depth of from two inches to a foot. The electric snow-ploughs, which are being equipped by the Sprague Company for use by the West End Road, had not been finished, and the cars were obliged to run without this aid for clearing the tracks. In spite of this, the cars ran very successfully over the entire distance of the roads, clearing their own way, and carrying large numbers of passengers. The president of the road and the directors expressed themselves as well pleased with the demonstrated efficiency and strength of the electric road, as exhibited during the snow-storm, even without the aid of the regular Sprague electric snow-ploughs. The *Boston Herald*, in an editorial of Jan. 17, in commenting on the road, said, "Those who have made the experiment of taking a ride on the new electric railway on Beacon Street must have come to the conclusion that this method of securing rapid transit in the suburban wards is one of the most promising that has yet been brought forward in this city. The speed attained, where the conditions are favorable, is quite equal to that of the elevated railroads in New York City, while the structures supporting the electric wires are by no means as much of a disfigurement as it was at one time supposed that they might be." So long as a mixed service is maintained,—that is, so long as some of the cars are drawn by horses,—the full advantage of the electric system cannot be realized. The speed of the electric car has to conform to the speed of the horse-car which may be in front of it; but, if the experiment proves as successful as there is now every reason to think that it may, the West End Company will before long feel compelled to substitute electric for animal power in the service of all of its lines. When that change is brought about, the speed that can be made, even in the centre of the city, will be very much accelerated over the average speed of to-day.

A SOUTHERN ELECTRIC RAILWAY STARTED.—During the past week the Asheville Electric Street Railway, which has been in course of construction for the last month under the Sprague Electric Railway and Motor Company of New York, was successfully put in operation. The first trial trip of the motor-cars was made on Jan. 21, in presence of the president, Mr. W. P. Penniman, jun.; superintendent, Mr. J. H. Barnard; and a number of prominent citizens,—Capt. T. W. Patton, Gen. Jonstone Jones, Dr. S. D. Pelham, and about sixty others; some being stockholders in the road, and others interested, directly or indirectly, in the success of the enterprise. The test proved a great success. The run was made over the entire distance of the line, about two miles, in less than eight minutes, carrying a large number of passengers. The citizens of Asheville are enthusiastic over the new electric line, and the direc-

tors of the road express themselves as very well pleased with the successful performance of the motor-cars.

A NEW SYSTEM OF ELECTRICAL DISTRIBUTION.—One of the problems which has claimed the attention of inventors in the past few years has been the conversion of high-tension to low-tension electric currents. The object is to distribute electric energy at a high potential, using comparatively small wires, and at the points of consumption to reduce the potential to that demanded by safety and the requirements of incandescent lighting. A large part of the cost of an incandescent electric plant is in the wires used for distribution; and the size of the wire required to distribute a given amount of energy varies inversely as the potential used. One of the most successful converter systems is that

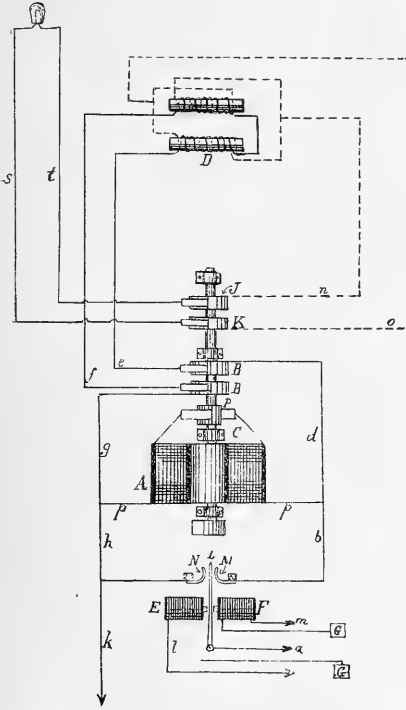

THE DICKERSON SYSTEM OF ELECTRICAL DISTRIBUTION.

used by the Westinghouse Company, where alternating currents are employed, and the reduction is effected by transformers,—induction-coils working backward. But there are some disadvantages in the use of alternating currents, and many attempts have been made to invent a continuous-current converter, that will do for continuous what the transformer does for alternating currents. Storage-batteries would offer an ideal method of effecting this, but for their cost and depreciation. Several mechanical methods have been tried, among others a motor-generator arrangement,—a combined motor and dynamo, the former supplied from the high-potential circuit, the latter supplying current at a low potential to the local circuit. Other plans have been proposed in which the main circuit is interrupted and advantage is taken of its inductive effect on the secondary circuit. None of these systems, however, are in successful operation on a large scale. Mr. Edward N. Dickerson, jun., of this city, received last week (Jan. 22) a patent on an improvement in his method of converting high-tension into low-tension currents. Feb. 14, 1888, a patent was granted Mr. Dickerson for a method of converting a direct high-tension cur-

rent into an alternating low-tension current; and by his recent improvement he is able to obtain a continuous low-tension current, which is a considerable advantage if the resulting current is to be used for a motor or for electric plating. The accompanying figures will make it clear how this result is obtained. A high-tension current flows out upon the circuit *a*, and returns to the generator by the circuit *b*. By the switch *L* it passes through the motor *C*. On the shaft of this motor is arranged the double reversing-commutator *BB*, the sections of which are alternately connected with the circuit *d* and with the circuit *g*. The current upon the circuits *g* is a high-tension reversing current, and operates the converter *F*, which converts the reversing high-tension current into a reversing low-tension current. This induced alternating current passes to the reversing-commutator *JK*, by which the reversing currents are rectified. It is of course essential that the two commutators shall move synchronously, and the commutator *JK* should be so adjusted on the shaft as to allow for the time required by the converter. The switch *EF* may be omitted; but by it it is possible to throw any house into circuit from the central office.

THE WESTINGHOUSE AND UNITED STATES COMPANIES.—An agreement is reported between these companies whereby their interests are united. The United States Company is one of the oldest electrical manufacturing companies, and has a large factory in Newark, N.J. The Westinghouse Company was already the lessee of the Consolidated and Sawyer-Man Electric Companies of New York, and the owner of the Waterhouse Electric Company of Hartford, Conn., and the Tesla Electric Light and Manufacturing Company of Rahway, N.J. The new combination has a manufacturing capacity of over 15,000 lamps a day, and the two companies own and control about 700 patents in every branch of electrical invention.

NOTES AND NEWS.

It is announced that a post-graduate department in electrical engineering will soon be established by the trustees of Columbia College, this city. A beginning will be made upon an economical scale, and the facilities will be increased in proportion to the patronage, which it is believed will increase rapidly, as New York is a city in or near which all or nearly all of the many applications of electrical science may be studied in practical operation. The course will be open to graduates of all scientific schools.

— An electrical exhibition will be held in the Chicago Exposition Building, in connection with the National Electric Light Association Convention on Feb. 19, 20, and 21. Many exhibitors have already secured space, the electric railway companies being especially forehanded in that respect. The exhibition, though not intended to be of long duration, promises to be interesting and important.

— The *Journal of the Society of Arts* reports the discovery of a new textile on the shores of the Caspian. This plant, called "kanaff" by the natives, grows in the summer, and attains a height of ten feet, with a diameter varying from two to three centimetres. By careful cultivation and technical manipulation, M. O. Blakenbourg, a chemist and engineer, who has made a special study of kanaff, has obtained an admirable textile matter. It is soft, elastic, and silky, gives a thread which is very tough, and can be chemically bleached without losing its value. The stuffs manufactured out of kanaff, and then bleached, can be successfully dyed in every shade of color, and would compete with any of the ordinary furnishing materials now in use. But it is particularly for making sacks, tarpaulin, ropes, etc., that this new textile, from its cheapness and its extraordinary resisting power, might defy all competition. Its specific weight is much less, but its resistance much greater, than those of hemp. Thus, a cord of 8.25 millimetres diameter, woven with the hand out of three threads of kanaff, requires a weight of 180 kilograms to break it. A cord half an inch thick, manufactured at Moscow, did not break till the weight of 625 kilograms was reached. When it is considered that Russia annually consumes more than one hundred and fifty millions of sacks, a third of which are imported, it may be easily seen that the appearance of this new textile on the Russian market is an event of no slight importance.

SCIENCE:

A WEEKLY NEWSPAPER OF ALL THE ARTS AND SCIENCES.

PUBLISHED BY

N. D. C. HODGES,

47 LAFAYETTE PLACE, NEW YORK.

[Entered at New York Post-Office as second-class mail-matter.]

SUBSCRIPTIONS.—United States and Canada.....	\$3.50 a year.
Great Britain and Europe.....	4.50 a year.
Science Club-rates for the United States and Canada (in one remittance):	
1 subscription 1 year.....	8 3.50
2 " " 1 year.....	6 00
3 " " 1 year.....	8.00
4 " " 1 year.....	10.00

Communications will be welcomed from any quarter. Rejected manuscripts will be returned to the authors only when the requisite amount of postage accompanies the manuscript. Whatever is intended for insertion must be authenticated by the name and address of the writer; not necessarily for publication, but as a guaranty of good faith. We do not hold ourselves responsible for any view or opinions expressed in the communications of our correspondents.

VOL. XIII. NEW YORK, FEB. 1, 1889. No. 313.

CONTENTS:

OIL-BURNING STRAM-ENGINES.....	73	Is the Race Degenerating?.....	87
WATER FILTRATION AND AERATION..	74	To Investigate Diseases of Swine...	87
THE CULTIVATION AND UTILIZATION OF RAMIE IN THE UNITED STATES OF AMERICA.....	75	MENTAL SCIENCE.	
AN AIR-SHIP.....	78	A Scientific Study of Sleep and Dreams.....	87
ELECTRICAL NEWS.		ETHNOLOGY.	
Hertz's Researches on Electrical Oscillations.....	79	Jade in Alaska.....	88
Another Electric Road at Atlantic City, N. J.....	80	Navajo Industries.....	89
West End Electric Road at Boston.	80	BOOK-REVIEWS.	
A Southern Electric Railway started	80	Elements of Machine Design....	89
A New System of Electrical Distribution.....	81	Gear Tables for laying out Accurate Tooth Profiles.....	89
The Westinghouse and United States Companies.....	81	The Secret Doctrine.....	89
NOTES AND NEWS.....	81	Healing Question.....	90
EDITORIAL.....	82	The Fundamental Orders of Connecticut.....	90
Politics in the Schools of New Jersey. — Capt. Zalinski's Pneumatic Gun. — The Government Printer		The Seventh Annual Report of the State Board of Health of New Hampshire.....	90
SOMETHING ABOUT TORNADOES		AMONG THE PUBLISHERS.....	90
<i>T. P. Finley</i>	83	LETTERS TO THE EDITOR.	
THE SITUATION IN SAMOA.....	85	Indian Relics from North Carolina	
HEALTH MATTERS.		<i>L. N. Johnson</i>	92
Poisonous Milk.....	86	The Characteristic Curves of Composition.....	92
The Pasteur Institute.....	87	<i>Appleton Morgan</i>	92
		The Permian Rocks of Texas	
		<i>Robt. T. Hill</i>	92

IT APPEARS that *Science* will have to widen the field of its activity in combating politics in the schools. New Jersey is suffering, apparently, as New York City is, but with this important difference: in New York the politicians are entrenched; in New Jersey they are seeking to gain possession. The situation is this. A year ago an inefficient State superintendent of public instruction was superseded, on the expiration of his term of office, by Col. Charles W. Fuller, a lawyer of high standing, and a man of force and character. In one year he has revolutionized the administration of the office. On every side evidences of new life and activity are to be seen. The best and most useful teachers' institutes in the history of the State were held last autumn, with excellent results. Manual training, compulsory education, increased salaries, and other important measures, have been aided by Col. Fuller's administration. It so happens, however, that Col. Fuller is a member of a certain political party, which is not the one in control of the legislature this winter. In this the politicians have found their opportunity, and, by arousing partisan passions, are straining every nerve to legislate Col. Fuller out of office. It is not believed that this disputable scheme will succeed, for every manly and fair-minded legislator, of whatever party, will oppose carrying politics into the schools. If the press of New Jersey expose the character of the contemplated legislation, it will surely fail.

ON THE 26th instant the board of naval officers continued its experiments with Capt. Zalinski's gun, the firing of which was to determine the accuracy of the range of the projectiles, which must, according to the requirements, fall within a rectangle 50 by 150 feet. The ranges were at 200 yards, 1,000 yards, and one mile; and although nothing positive can be stated, as the official report has not yet been made public by the Navy Department, it is confidently believed that the trial, which showed effective action of over 50 per cent of the shots fired, will be a triumph for the company that has so boldly attempted to solve the problem of projecting large masses of high explosive at a sufficient rate of speed to insure accuracy in the flight of the shell containing the explosive. Should the trial be considered as not satisfactorily answering every requirement of the specifications, it would be some two weeks before another trial could take place, owing to there not being a sufficient number of projectiles on hand. The official table of data of the trial, including the range of each projectile, is given below. It will be seen from the column of ranges that five projectiles fell within a rectangle of 50 feet by 100 feet, or the limits specified by the contract. These shots were Nos. 1, 4, 5, 6, and 9 in the order of firing. There being nine shots fired in all, it is seen that 50 per cent came within the rectangular limits. But the question is, Will the board consider the spirit of the contract fulfilled by the above, or, if the members do report favorably on the gun's accuracy, will the secretary of the navy demand a second trial and a rigid adherence to the contract provisions, as shown in the report of the trial? The following is the official table of Saturday's trial:—

No. of Fire.	Ranges.	Weight of Projectile.	Loss of Pressure.	Time of Flight.
1	2,177	450	125	Lost.
2	2,017	452	122	11 3/4
3	2,009	453 1/2	105	12 1/4
4	2,159	451 3/4	123	12
5	2,156	445	125	11 3/4
6	2,127	448 1/2	123	12*
7	2,055	454	110	11 2-5
8	2,090	483	220	13
9	2,154	440	125	12 4-5

* Approximate.

The elasticity of the requirements under which the trial was conducted may permit of the above being taken as satisfactory to the government, inasmuch as the firing at the 1,000 and 200 yards' ranges in itself proved the accuracy of the new guns.

ALL SCIENTIFIC MEN in government employ whose works will pass through the Government Printing-Office will be gratified, that, by the common consent of those who know him best, Alexander R. Hart of this city has been put forward as the best qualified and most available candidate for public printer under the new administration. For several years he has prepared engravings and illustrations of a scientific nature for the Smithsonian Institution, the United States Fish Commission, and other departments of the government. He has long been at the head of one of the best-organized and most thoroughly equipped printing and engraving establishments in this city, if not in the world. He is acknowledged to be a man of splendid executive ability, and he possesses a thorough knowledge of the printing and engraving business, down to the most minute details. He has worked his way from the foot of the industrial ladder by just such qualities as fit him for the position now suggested for him, where he would command the respect not only of those under his supervision, but also of all others who, socially or officially, should be thrown into contact with him.

SOMETHING ABOUT TORNADES.¹

WHERE atmospheric equilibrium is violently decomposed and the agitation covers but a very limited area, the centripetal force becomes much greater than in the case of cyclones. The gyrations are exceedingly rapid and very near the centre; in fact, the violence is greatest at the centre, and diminishes rapidly to the external parts of the disturbance, where the gyrations cease altogether. This form of disturbance is called a tornado. In order that conditions may become favorable for tornadic development, the atmosphere must assume the unstable state. This state will be engendered whenever the rate of decrease of temperature is greater in the surrounding quiet air than it is in the mass of ascending air. The adverse or counter movement of northerly and southerly winds induces the unstable state, because it makes the rate of decrease of temperature greater in the quiet air than in the column of ascending air; that is, the upper strata of the air will be made colder, and the lower strata warmer.

What are known as local storms, under this class of motions of the atmosphere, are not affected by the rotation of the earth upon its axis, because the area of disturbance is too small. The progressive motion of tornadoes to the north-east arises from the fact, that, as they always form in the south-east quadrant of an area of low barometer, they must come within and under the influence of the general drift of the atmosphere on that side of the "low," which, according to the law of atmospheric circulation about the centre of an area of low pressure, is always to the north-east.

The condition of tornado-formation in regard to heat is simply that of unstable equilibrium for saturated air at the existing temperature, the other condition being that the air shall have a gyratory motion relative to some central point, arising from any cause whatever. In the unstable state, the lower strata of the atmosphere are liable to burst up through the upper layers at any point where there may chance to exist some slight predetermining cause, which is never wanting, arising from local conditions of temperature and moisture.

When an upper motion of the atmosphere is started at any point, the air thus engaged is kept warmer, and therefore rarer, than the region immediately surrounding it. This continues as long as the ascending current is supplied with air nearly or quite saturated, or until, from an inversion of the air in the lower strata, the state of unstable equilibrium is changed. The violent whirling motion of the air which characterizes the tornado is dependent upon a pre-existing disturbed and gyrating state of the atmosphere. The case is somewhat similar to that of water in a shallow basin running out through a hole in the centre. If the initial state of the water is that of perfect rest, it flows directly toward the centre with a very slow velocity; but, if there is the least initial disturbance of a gyratory character when the water first begins to flow, it soon runs into rapid gyrations around that centre.

As we have shown, therefore, there are two principal conditions upon which the occurrence of tornadoes depends, and in the absence of either of which they cannot take place. The one is the state of unstable equilibrium of the air, and the other a circulation motion with reference to any centre of disturbance. It is not imperative that the central area shall be stationary, but simply that the motion of the air around it shall be such that when the latter is drawn in toward the centre it will take a gyration around it. When these two principal conditions are present, there is scarcely ever wanting the secondary condition, which, through the effect of some slight initial disturbance, gives rise to an upward burst of the air through the overlying strata. The places and time most favorable to the development of unstable equilibrium and a gyratory motion of the atmosphere are those in which tornadoes are most likely to occur. Of these two conditions, the unstable equilibrium is the most important, since it more rarely occurs than the other, which is scarcely ever so entirely absent as not to give some slight gyratory motion, which becomes violent very near the centre. The question naturally occurs, Where are the places on the earth's surface, and what is the time, when conditions are most favorable for the development of tornadoes?

First, as to places. These are found where, in the general motions of the atmosphere as affected by continents and mountain-ranges, currents of the air at the earth's surface, which come from a warmer latitude, or at sea from a much warmer continent, are caused to flow under the colder upper strata, where the normal motion is nearly eastward, and where consequently the temperature is the normal one, not affected by such motions as take place in the lower strata: in other words, tornadoes are most likely to occur in regions where warm, moist air flows underneath a colder and dryer upper strata, coming from another direction. Such regions are found particularly in the Mississippi, Missouri, and Ohio valleys, and in Alabama, Georgia, and the Carolinas. The other condition — viz., a relative gyratory motion with regard to any point — is found to an unusual extent in the regions above named, especially in the winter season, which fact accounts for the frequent occurrence of tornadoes in the Southern States during the winter and spring, and occasionally in the Mississippi and the Ohio valleys.

Second, as to time. The summer season is the most favorable for tornadoes, when the interior of the continent is warmed up, and the air of the lower strata is drawn from lower latitudes far up into the northern portions of the country on the eastern side of the Rocky Mountains, and the isothermal curve is deflected very decidedly toward the north. From this cause the temperature of the lower strata of this region becomes much higher than that of the superdominant strata; and, if this condition does not of itself induce the unstable state, it is readily accomplished by the addition of any small effect from some other cause, as from extremely warm weather, in which the earth's surface and the lower air strata become abnormally heated.

The great moisture of the air in the southerly winds is also favorable to the induction of the unstable state, since such a change is more readily brought about in air nearly or quite saturated. The southerly currents curving eastward from the Rocky Mountain and Appalachian ranges give rise to a general air movement of considerable force toward the Atlantic Ocean, as the result of which, cold counter currents pass southward to Texas, east of the Rocky Mountains, and to Florida over the Appalachian range, somewhat after the manner of the Arctic currents which flow southward to Florida, between the Gulf Stream and the coast of the United States.

In the summer season this flow of cold air southward is confined to a comparatively narrow belt east of the Rocky Mountains, for at that time the warm, moist currents of the Gulf are drawn very far to the north and west. At this season the northern part of Texas has the same mean temperature as Minnesota, the isotherms being nearly north and south in direction; and the temperature gradient between the warm southerly winds on one side, and the cold northerly currents on the other, is similar to that of the cold wall between the Gulf and Arctic currents.

In the winter and spring the flow of cold air southward from the higher latitudes extends to the Appalachian range, where it overflows the warm, moist southerly currents from the East Gulf and South Atlantic coast. It is this tendency of the air to flow in contrary directions, where the conditions are most favorable to produce the unstable state of the atmosphere, that pronounces the regions here indicated as the "battle-ground of tornadoes." The word "low," as is quite well known, marks upon the weather-map the centre of lowest pressure as indicated by the barometer and direction of the wind. This is practically the centre of the general storm or atmospheric disturbance.

1. The conditions for the development of tornadoes are most favorable in the south-east quadrant of a "low:" in fact, they are not to be looked for in any other portion of the general disturbance. 2. Tornadoes very generally accompany a "low," for the reason that the condition of unstable equilibrium necessary in the formation of a tornado is also required in the "low," at least in the upper cloud-region. 3. The unstable state in a "low" very rarely extends down to the earth's surface, so that tornadoes are not necessarily visible in every general storm. 4. There are frequently secondary whirls, incipient tornadoes, in the cloud-region of a "low," the effects of which do not reach down to the earth's surface, and the only visible effect above is the formation of a local

¹ Portion of a paper read before the National Geographic Society of Washington, Nov. 16, 1888, by J. P. Finley.

cloud a little denser and darker than the clouds are generally. 5. A hail-storm is an incipient tornado in the cloud-region of a "low." 6. Tornadoes always occur in the south-east quadrant of a "low," and at distances generally of from 200 to 500 miles from the centre. They are not likely, however, to occur in the south-west and north-west quadrants of a "low," because the currents and counter currents there are nearly east and west; and hence the effect is neutralized, tending neither to produce nor destroy the unstable state. As the "low" progresses eastward, the region of country lying, on the average, about 350 miles to the south and east of the centre of the general storm at any time, is the region within which tornadoes may be expected.

The destructive violence of a tornado is sometimes confined to a path a few yards in width, or it may widen to the extreme limit of eighty rods. The tornado, with hardly an exception, occurs in the afternoon, just after the hottest part of the day. The hours of greatest frequency are 3.30 to 4 P.M., and 4.30 to 5 P.M. The destructive power of the wind increases rapidly from the circumference of the storm to its centre. Observations with a single barometer will not indicate the approach of a tornado, however near the position of the instrument to the path of the storm; and such observations are of value in this connection, only when a number of them are displayed upon the weather-map. The tornado season includes the months of March, April, May, June, July, August, and September. There are, however, cases in a long series of years where tornadoes have been reported every month of the year. The months of greatest frequency, as determined from a record of 206 years, are April, May, June, and July. The month of greatest frequency is May, April coming next on the list. The State in which the greatest number of tornadoes have occurred is Missouri, followed next in order by Kansas and Georgia. The 425 tornadoes and "windfalls" recorded in Wisconsin far exceed the number from any other State; but little weight can be given this fact, owing to the want of a similar investigation of the subject of "windfalls" in other States. The violence of tornadoes expressed relatively by States places Missouri first, succeeded by Iowa and Alabama. By "violence" in this sense is meant the most completely developed storms with perfect conditions longest sustained.

Considering the entire record of eighty-eight years (years of record from 1682 to 1888), nearly 4,000 persons have been reported killed, and 6,000 injured. This record is very imperfect, owing to the large number of cases in which the killed and wounded were not definitely reported. The States in which tornadoes have proved the most destructive to life are in relative order as follows: Missouri, Mississippi, Iowa, Illinois, Minnesota, Wisconsin, and Ohio.

Considering the reported valuation of property destroyed, the following States have experienced the most destructive storms, and in the order named: Missouri, \$94,325,000 in forty-seven years; Ohio, \$87,737,500 in eighty-four years; New York, \$67,000,000 in one hundred years; Kansas, \$64,000,000 in twenty-nine years; Georgia, \$56,500,000, in ninety-three years; Minnesota, \$50,750,000 in thirty-three years; Iowa, \$49,575,000 in forty-five years; South Carolina, \$46,875,000 in one hundred and twenty-seven years. These values are necessarily approximate, owing to the imperfect reports, and it is believed that they fall considerably short of the actual amount of loss.

It is a difficult matter to obtain reliable estimates of the actual value of property destroyed by tornadoes in the United States, since the date of the earliest records; viz., June, 1682. Although the average yearly occurrence of these storms has probably remained unchanged, and will continue so, yet the value of the property subject to destruction by them has increased enormously, and the amount is constantly enlarging as the country advances in wealth and population. Where fifty years ago the tornado swept a barren plain or trackless forest, it now crushes and overwhelms prosperous cities, and devastates rich and populous agricultural districts.

The approximate aggregate loss to property by tornadoes, considering the number of storms reported, is nearly one billion of dollars. Considering the number of years embraced in the period of observations and the average yearly number of tornadoes, the amount is nearly ten billions of dollars. This estimate is probably

in excess of the actual loss, because no allowance is made for the many storms which have occurred since 1682 without appreciable waste. Taking the past thirty years as affording more satisfactory information, and considering the average yearly occurrence of tornadoes as 146, the approximate aggregate property loss foots up about two billions of dollars.

A comparison of yearly values, as obtained from carefully prepared tables showing the number and geographical distribution of tornadoes, might lead one to the conclusion that these storms were on the increase. Such a deduction would certainly be erroneous, and for the following reasons. First, From a careful investigation of the origin of tornadoes and their geographical distribution, there is every reason to believe that these storms were as frequent and violent two hundred years ago as now. Moreover, there appears to be no cause for any unusual change in the annual frequency of tornadoes for a like period to come. Second, It must be considered that during the past ten years the Signal Service has had great facilities for collecting reports; and the rapid growth of the country, with a greater zeal of the press, has brought to light the occurrence of many storms which otherwise would not have been reported. Third, The statistical tables are not sufficiently complete, especially prior to 1875 (without which period it would not be safe to make deductions), to permit of reliable conclusions as to periods of maximum and minimum occurrence. It is not unlikely that such variations exist, and that they depend upon the relation of heat and moisture to the general condition of the atmosphere. The more frequently the unstable state of the atmosphere is produced, together with a relative gyratory motion, the more favorable are the conditions for the occurrence of tornadoes, and *vice versa*. Fourth, In the region between the 95th and 107th meridians, tornadoes still occur without causing much damage, because of their passage over thinly settled portions of the country. Owing to this fact, little attention is given to these storms; but this indifference will soon disappear, as the country rapidly settles up and every appearance of the cloud-monster is marked by death and destruction. Fifth, The years (118) that are missing in the period of 206 years from 1682 to 1887 inclusive are not to be considered as years in which no tornadoes occurred, but as years in which records are wanting owing to failure of observations.

Considering the past ten years (1878 to 1887 inclusive) as furnishing reliable and exhaustive records of tornadoes, and that the period prior to 1878 (196 years, 1682 to 1877 inclusive) is deficient owing to want of facilities in collecting reports, we may give an interpolated value for each of these latter years, as determined from the complete ten-year record. This value is found to be 146, which means, that, on the average, 146 tornadoes will occur in the United States.

Applying this constant to existing records, we have a grand total of storms from 1682 to 1887 inclusive (206 years) of 30,076 tornadoes, instead of 2,435 actually observed and reported. This would indicate a failure to report the occurrence of about 27,641 tornadoes which have probably passed over portions of this country since 1682. In that year a very destructive tornado, with distinct funnel-shaped cloud, visited New Haven, Conn., at 2.30 P.M. on the 10th of June. It is the very long interval of 118 years, during which records are entirely missing, that makes the discrepancy so great in the grand totals.

No well-authenticated case of a tornado has been reported from the region of country lying west of the 105th meridian, and it may be generally stated that these storms do not occur in the United States west of the 100th meridian. The cause for this is found in the lack of favorable conditions, on account of the dryness and the lower temperature of the air, and the want of uniformity in the direction and force of surface currents. Violent straight winds, attended with considerable destruction to property, have been reported several times in the past fifteen years, from southern and central California, Arizona, New Mexico, and Montana.

Much has been said and published concerning the influence of forests upon the occurrence and destructiveness of tornadoes, and many people believe that where timber grows in great abundance, tornadoes cannot occur. By comparing the number of tornadoes in each State with the acreage of forests, as estimated in the last census report, it is found that the latter appear to have no percep-

tible influence in preventing the occurrence of tornadoes, or in assuaging their violence.

In this connection, it should not be forgotten that the conditions which give rise to the development of tornadoes exist in the cloud-regions of the atmosphere, and not at the surface of the earth. Forests would prevent the occurrence of whirlwinds, because these phenomena depend upon the unstable state of the atmosphere at the earth's surface, where the conditions are favorable for the sun's heat to accumulate in the surface strata of the soil, and thus superheat the air resting upon it. A heavy growth of timber or rank vegetation will prevent this action of the sun's rays.

Whenever a tornado-cloud encounters a forest, the destruction is complete and terrible. The forces of the tornado-cloud are quickly brought into operation, and maintained continuously while the phenomenon exists. They are not affected by having to meet in rapid succession totally different objects, different in size, strength, shape, materials, composition, structure, relative position, etc.

The width of the path of destruction, as determined from the records of 88 years, varies from 10 to 10,560 feet, the average being 1,369 feet. The length of the tornado-track varies from 300 yards to about 200 miles, the average being 24.79 miles. The velocity of progression of the tornado-cloud varies from 7 to 100 miles per hour, the average being 44.11 miles. These extremes may often occur in different portions of the track of a single tornado. The shortest time occupied by the tornado-cloud in passing a given point varies from "an instant" to about 20 minutes, the average being about 74 seconds.

The month of greatest frequency, that is, the month embracing the largest number of days in which tornadoes occurred, is May. The prevailing direction of the progressive movement of the tornado-cloud is north-east. The vortex wind velocities of the tornado-cloud vary from 100 to 500 miles per hour, as deduced from actual measurements. Velocities of from 800 to 1,000 miles per hour are extremes that have been reported, but may not be altogether reliable. Theoretical velocities of 2,000 miles and over per hour, based upon certain assumed atmospheric conditions, have been deduced. Such velocities are mathematically possible, but not meteorologically probable.

The concomitants of the tornado are, an oppressive condition of the air; the gradual setting-in and prolonged opposition of northerly currents and southerly currents over a considerable area; a high temperature, and the presence of considerable moisture; a gradual but continual fall of the thermometer with the prevalence of northerly currents, and a rise with the predominance of southerly; a rapid decrease of temperature with increase of altitude; a decided gradient of temperature across the line of progressive movement; huge masses of dark and portentous clouds in the north-west and south-west, possessing a remarkable intensity of color, usually a deep green; a remarkable rolling and tumbling of the clouds, scuds darting from all points of the compass towards a common centre; hail and rain accompanying the tornado, the former either in unusual size, form, or quantity, and the latter either remarkable in quantity or size of drops; the presence of ozone in the wake of the tornado; a remarkable roaring noise, like the passage of many railroad-trains through a tunnel.

The cloud generated by the vortex assumes the form of a funnel, with the smallest end towards the earth. This explains the remarkable contraction of the storm's path. Upon reaching the earth's surface, the vortex has four motions: viz., first, the whirling or gyratory motion, always from right to left; second, the progressive motion, generally from some point in the south-west quadrant to some point in the north-east quadrant; third, the curvilinear motion; fourth, oscillatory motion.

The characteristic effects of a tornado are, objects are drawn towards the vortex from every point of the compass; objects passing into the vortex are thrown upwards and outwards by the vortical action of the engaged air; structures are literally torn to pieces by the vortical action of the air, evidence of which is afforded by the fineness of the *débris*, and also its disposition in the storm's path; the *débris* is thrown inward from each side of the storm's path; light objects are carried to great heights and also to great distances; objects are carried inward and upward by the centripetal, and outward by the centrifugal, forces of the vortex; weight

and size are conditions which generally present immaterial values to the power of the tornado; persons are stripped of clothing; fowls and birds are denuded of feathers and killed; trees are whipped to bare poles; heavy objects are carried for miles in the air; long and heavy timbers are driven to considerable depths in the solid earth; the vortex is completely filled with flying *débris*; timbers are driven through the sides of buildings; sand and gravel are driven into wood; the strongest trees are uprooted, or twisted off near the roots; men and animals are terribly mangled by contact with flying *débris* and by being rolled over the ground for a considerable distance; in the path of the storm all vegetation is destroyed; railroad-trains are thrown from the track; iron bridges are completely dismantled and carried from their foundations; heavy bowlders, weighing tons, are rolled along the earth; the largest railroad-engines are lifted from the tracks on which they rest; all objects, whether metal or non-metallic, magnetic or non-magnetic, simple or compound, animate or inanimate, are acted upon in a similar manner.

THE SITUATION IN SAMOA.

THE continuous disturbances on the Samoa Islands, and their bearing upon questions of great political importance, give to these islands a special interest. The group consists of thirteen islands, only three of which are of commercial interest,—Savaïi, Upolu, and Tutuila. Savaïi is the largest island of the three, measuring some 40 miles from east to west by 20 miles from north to south, and having an area of 700 square miles. It has no harbor of any importance, and in this respect it contrasts strongly with Upolu and Tutuila. The little bay of Mataatu, in the extreme north of the island, is the only place where large vessels can anchor; but even it is not safe from November to February. The interior of the island is occupied by two mountain-ranges of volcanic origin. It has no rivers or streams, the water filtering away through the porous soil. Where the mountains approach the coast, the latter is very steep and inaccessible, while in other places a well-wooded strip of alluvial land is found, on which numerous villages are situated. The sterility of the interior of this island has always been a barrier to all settlement or cultivation, and even to the visits of travellers and explorers.

Upolu, which covers an area of 550 square miles, is also mountainous, but it is well wooded and fertile, and possesses several considerable streams, although they are, of course, not navigable. On the northern coast of this island lies Apia, the chief town of the whole Samoan group. It is prettily situated, having a background of mountains thickly wooded, and a foreground of harbor and coral reefs. The harbor consists of two portions, the most westerly being the best for vessels that intend to remain for any length of time, especially during the rainy season. For sailing-craft, a steady breeze is absolutely necessary on entering or leaving the harbor, as a strong current sets along its entrance.

Passing down the coast east of Apia, a succession of beautiful bays are met with. At the distance of from half a mile to two miles from the shore a coral reef protects this portion of the island for nearly twenty miles. At high tide canoes and boats can pass between this and the mainland, and thus a great deal of the insular traffic is carried on.

As seen from the sea, there are not many islands in the Pacific that present a more beautiful or picturesque appearance than Upolu. It shows a bold and majestic front, the central range being not less than 3,000 feet high, and wooded almost to its summit. It is throughout a very fertile island, and fully equal to the best portions of the Fiji group.

Tutuila is about 17 miles long and 5 broad. On its southern side is the deep bay of Pagopago, which almost cuts the island in two. This harbor, which is one of the best in the whole South Pacific, is surrounded by hills from 2,000 to 3,000 feet high. Surrounding the harbor at their base is a small strip of level land. The harbor is half a mile wide at its entrance, and runs north and south for a distance of a mile, when it turns in a westerly direction, and opens out into a fine sheet of water. It is somewhat difficult for sailing-vessels to leave, in consequence of the trade-winds blowing directly into it; but for steamboats it is unsurpassed by

any harbor among all islands of the South Pacific. Here vessels of any size can lie at anchor, secure from every wind, all the year round. It is well adapted as a coaling station or for refitting and repairing ships, and affords, moreover, plentiful supplies of timber, food, and water.

Upolu, and to some extent Tutuila, have attracted a considerable number of American and European capitalists, the latter mostly Germans; and a large portion of the land has passed into the hands of foreign residents, who number about three hundred. The bulk of the foreign trade belongs to the successors of the famous Hamburg firm of J. C. Godefroy & Son. Cotton, coconuts, and bread-fruit are cultivated for export; and maize, sugar, coffee, etc., for local consumption. Copra (dried coconuts) is the most important article of trade. In 1881 the planters had about 1,800 laborers from the Line Islands, New Britain, New Hebrides, etc., the Samoans being too independent to hire themselves out.

under the protection of German guns. Tamasese is, of course, as much of a puppet in the hands of the Europeans as Malietoa has always been. The conflict between the native parties has reference not so much to whether the one or the other person be king, as to the question of whether Germany or England-America shall retain the upper hand.

HEALTH MATTERS.

Poisonous Milk.

PROFESSOR L. P. KINNICUTT of the Worcester (Mass.) Polytechnic Institute reports to the *Boston Medical and Surgical Journal* five cases of poisoning by milk in which, upon chemical analysis, he found tyrototoxic.

The milk was in a pint beer-bottle with patent rubber stopper, and appeared and tasted perfectly fresh and good. After carrying it to the laboratory, it was allowed to remain in the tightly stop-

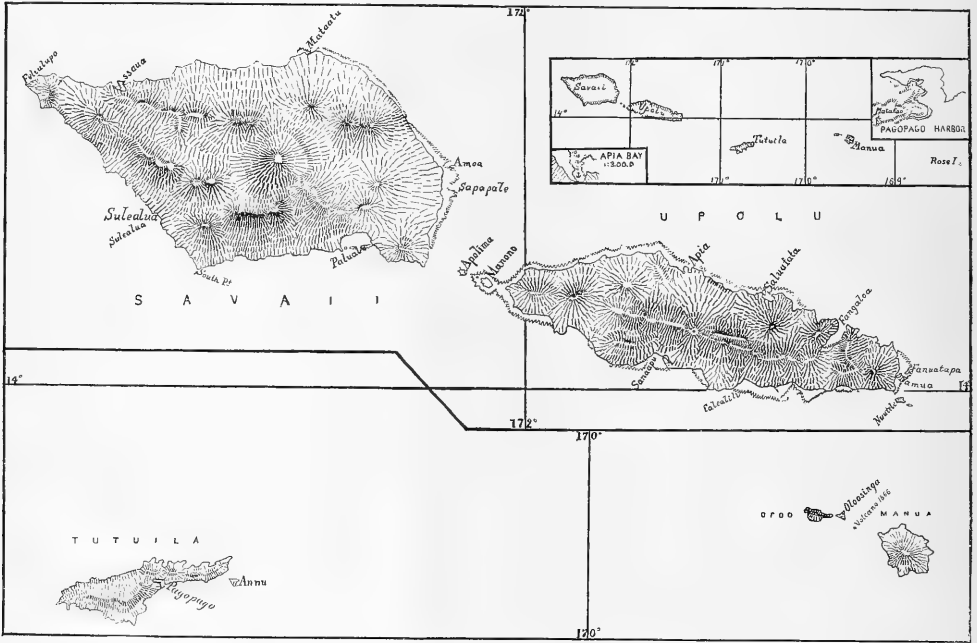

MAP OF THE SAMOA ISLANDS.

Among the natives of these islands dissensions have always been raging, and the European traders did not fail to take advantage of their internal wars. In 1860 the firm of Godefroy, which at that time encountered no considerable competition in the Pacific, stood on the side of Malietoa, a chief belonging to one of the most distinguished families of Samoa. Although Malietoa was never in reality ruler over the whole group of islands, he assuredly had the expectation of the first place in the country, and the royal title was formerly willingly given him.

Throughout the next twenty years, which passed with continuous dissensions among the natives, the Europeans who had gradually settled in Samoa, Germans, Englishmen, and Americans, found abundant opportunity to meddle in the quarrels of the inhabitants, which they did accordingly in the fullest measure. They sought, by taking sides with or against Malietoa, to strengthen respect for their nations, and thereby increase their commerce. Since Malietoa was influenced principally by Americans, the German Commercial and Plantation Society, who had originally supported him, took the opposing side, and in 1887 helped Tamasese to dethrone his old adversary. Before the recent uprising, a German, Tamasese's prime minister, was in reality possessor of all power,

pered bottle for one week before it was examined. The milk had by that time decomposed, separating into two layers. It was filtered through thick Swedish filter-paper, the filtrate neutralized with a dilute solution of sodium hydrate, placed in a separating-funnel, and shaken thoroughly with ether. A thick emulsion formed, and it was only after four days, and by the use of various mechanical means, that a separation could be effected. The ether solution was allowed to evaporate at the ordinary temperature, and the residue carefully tested. Re-actions were obtained which agreed perfectly with those given by Vaughan (*Journal of Analytical Chemistry*, vol. i. pp. 25 and 281) for tyrototoxic. There is therefore no doubt that the poisonous action of the milk was caused by the same poison that Vaughan found in the various cases cited by him.

A visit to the dairy from which the milk was obtained was made, and it was found that the herd consisted of fifteen Jersey cows, all in the best condition, well fed and cared for. The dairy supplies about forty families with milk, and the milk of all the cows is mixed together before subdividing it into the various portions; and as only one family out of the forty supplied with the milk, as far as can be found out, suffered from any poisonous effect, it proves that

the poison was developed after the milk had been delivered. This was also found to be the fact on questioning the servants of the family poisoned. The milk had been received in a tin can, which it was their business to keep clean, and it had been immediately subdivided into two portions. One portion was placed in an earthen dish to raise cream, and the other was used during the same morning as fresh milk, without causing the slightest trouble. The symptoms of poisoning were caused by the first portion, after standing over night. The above facts seem to show that the tyrotoxin was developed during the twenty-four hours after the milk was received.

The only explanation of its development that can at present be given is, that the cans used for obtaining the milk had not been thoroughly scoured with boiling water, and that a little old milk remaining on the inside edges of the can had undergone a peculiar fermentation, and had caused the development of a sufficient amount of tyrotoxin, during the twenty-four hours it had remained in a cool place, to produce the poisonous action.

Professor Kinnicutt describes thus fully the above case, as up to this time almost nothing is known as to the cause of the formation of tyrotoxin in milk. He has, he thinks, pointed out one way in which it may be developed, namely, the use of cans which have not been kept perfectly clean; but it is only by the careful examination of a number of cases that it will be possible to decide whether the formation of the poison is due solely to such causes.

THE PASTEUR INSTITUTE.—The Paris correspondent of the *New York Medical Record* contributes to that journal an interesting letter describing the opening of the Pasteur Institute, which occurred Nov. 14, in the presence of a large assembly presided over by the President of the Republic. The proceedings were opened by M. Bertrand, permanent secretary of the Academy of Sciences, who made a eulogistic speech on M. Pasteur and his numerous scientific researches. Dr. Grancher, M. Pasteur's principal assistant, then read a report of the work done in antirabic inoculations since the middle of 1885, when the first two human beings were inoculated. He stated that the number of persons treated at Paris in the Rue d'Ulm and the Rue Vauquelin during the years 1886-87 to July 31, 1888, was 5,384. The rate of mortality had been 1.34 per cent for 1886, for 1887 it was 1.12, and for 1888 it was 0.77 per cent. This rate of mortality comprises the deaths of persons who were affected with rabies the day after inoculation; but, remarked Dr. Grancher, even these figures are very striking, as the estimated mortality previous to the discovery of this method of treatment was 15.90 per cent as given by the reporter of the Council of Hygiene of Paris. Dr. Grancher informed his hearers that twenty laboratories for antirabic inoculations have been established in different parts of the world,—seven in Russia, five in Italy, and one each in Roumania, Austria, Brazil, Cuba, and the Argentine Republic,—while two more will shortly be opened at Chicago and Malta. The staff of the new institute are disposed of as follows: Dr. Grancher, with the assistance of Drs. Chantemesse, Charrin, and Terrillon, will attend to the department of the treatment of rabies; M. Duclaux, one of M. Pasteur's most ancient pupils, and now professor of biological chemistry at the Faculty of Sciences, will direct the laboratory of general microbiology; M. Chamberland is charged with microbiology in its relations with hygiene; Dr. Roux will teach the microbial methods in their applications to medicine; Drs. Metchnikoff and Gamaleia of Russia will study the morphology of inferior organisms and comparative microbia. The new institute will thus, as expressed by M. Pasteur, serve as a dispensary for the treatment of rabies, and will at the same time constitute a centre of researches for infectious maladies, as well as a centre of instruction for the study of microbiology, and will be open to medical men of all nationalities.

IS THE RACE DEGENERATING?—An English newspaper has been making a collective investigation regarding the questions given below: "1. Does your experience suggest to you that the race of Englishmen is degenerating physically? 2. Do you think that the great advance in the healing art is responsible for keeping alive much weak life that will in time affect the whole race injuriously? 3. Do you think that the increased indulgence in physical sports has, on the whole, a good influence on health? 4. Has it ever

struck you that probably the great attention paid to health in these days may be producing an anxiety about bodily ailments which is a disease in itself?" Answers have been received from a long array of practitioners, among whom are the names of eminent London physicians. The general view taken, according to the *Medical Record*, is that Englishmen are not degenerating, but that, on the whole, the race is improving in vigor.

TO INVESTIGATE DISEASES OF SWINE.—The commissioner of agriculture has appointed a commission, consisting of Professor William H. Welch of Johns Hopkins University, Dr. E. O. Shakespeare of Philadelphia, and Professor T. J. Burrill of the University of Illinois, to investigate the subject of swine-diseases in the United States, and the methods of their treatment and prevention.

MENTAL SCIENCE.

A Statistical Study of Sleep and Dreams.

THE application of general scientific methods to the problems of mental action has everywhere brought results of interest and value, and especially pleasing has been the success attending the study of the statistics of mental phenomena. Observations in themselves trivial, apparently accidental even, when intelligently grouped together, bring to light truths only dimly suspected and poorly understood. The errors of individuals in part disappear in the average, and results obtained by one method are controllable by others. A very striking innovation, with the help of the statistical method, into an obscure region of mental action, is attempted in a recent study coming from the University of Dorpat, Russia.¹ A series of questions were drawn up, and five hundred copies distributed. Of these, over four hundred were returned filled out; and it is upon these answers, which the author declares unexpectedly clear and accurate, that the conclusions of this paper are based.

Each observer, after stating his name, age, sex, and occupation, set himself to answering the following questions regarding his sleep and dreams. The persons were divided into three classes: 1. Students (151 in number); 2. Other males (113); 3. Females (142).

I.—Dreams.

1. Do you dream every night, frequently, seldom, never? "Nearly every night" was grouped with "every night," making 99 such answers; "frequently," "very frequently," etc., were reported 133 times; "seldom," etc., 153 times; and "hardly ever," or "never," 15 times; 6 were undecided.
2. Are your dreams vivid? This was answered affirmatively 216 times; negatively, 175; undecided, 15.
3. Can you well remember your dreams upon awakening? "Yes," 194; "no," 203; "undecided," 9.

II.—Sleep.

1. When do you go to bed?
2. When do you rise?
3. Are you tired in the morning upon awakening? Do you become tired early in the evening? 38 were tired both morning and evening, 104 in the morning only, 95 in the evening only, 169 at neither time.
4. How long does it take you to fall asleep? This question is difficult to answer, and the general tendency will be to overestimate the time; and this was partly taken into account.
5. Do you sleep through the night without awakening? "Yes," 261; "no," 143; "undecided," 2.
6. Is your sleep deep, or light? Is it easy, or difficult, to wake you? "Light," 202; "deep," 166; and 26 reported "deep sleep, but easy to wake."
7. Can you go to sleep at day-time when desired? "Yes," 103; "no," 294; "undecided," 9.
8. Are you accustomed to sleep at day? When and how long? This question was used with Nos. 1 and 2 to obtain the duration of sleep per twenty-four hours.

¹ Statistische Untersuchungen über Träume und Schlaf, von Friederich Heerwagen, in Philosophische Studien, v. 2, 1883.

III.—*Work, Disposition.*

1. When is mental labor easiest to you? "In the forenoon," 182; "late in the afternoon," 6; "at evening and night," 133; "forenoon and evening," 43; "no difference," 28.

2. What is the nature of the work? The object was to ascertain whether the kind of work limited the time of doing it, but the question was not successfully formulated.

3. Do you suffer with nervous disorders (headache, uneasiness, moodiness)? A decided "no" was given only 18 times; "seldom," 196; and "yes," 210.

4. Is your temperament sanguine, choleric, phlegmatic, or melancholic? "Sanguine," 132; "choleric," 70; "phlegmatic," 74; "melancholic," 20; various combinations, 102.

The results for the two sexes were so different that they demanded separation, while the students formed a homogeneous class interesting as a special study. The first problem that was proposed was the relation between the frequency and the vividness of dreams. It appears that 62.5 per cent of those who dream every night dream vividly, 60.5 per cent of those who dream frequently, and only 26.8 per cent of those who dream seldom, showing that the vividness of dreams increases very markedly with their frequency.

Next, how is the intensity of sleep related to the frequency of dreams? Of the students who dream nightly, 68 per cent have a light sleep (and only 28 per cent a deep sleep); of those dreaming frequently, 40 per cent; of those dreaming seldom, 32.8 per cent. Similar percentages for the other males are 68.8, 42.1, and 39.3; and for women, 72.4, 60, and 50 per cent. We conclude, then, that frequent dreams are a concomitant of light sleep, though the relation is far from universal.

These are the questions that formed the starting-point of the investigation. The rest of the information is grouped together in one large table and an admirably arranged diagram, from which more conclusions can be drawn than can find mention in this *résumé*. Those that the author singles out may be noted.

As regards sex, women have 73 per cent of their number dreaming nightly or frequently, while students have only 50 per cent, and the other males 48 per cent. Again: 63 per cent of the women sleep lightly, and only 42 per cent of students, and 44 per cent of other males. We conclude, then, that women have a very much lighter sleep than men, and that their dreams are proportionately more frequent.

Another conclusion, the evidence of which is too detailed to present, is, that as we grow older, our dreams become less frequent, but our sleep becomes lighter; age affecting the intensity of sleep more than the frequency of dreams. The author regards the students as in the period of maximum dreaming (twenty to twenty-five years of age). The deep sleep of childhood (hostile to frequency of dreams) is then least counterbalanced by the lessening of dreams due to age. The vividness of dreams shows a similar relation to age and sex: the women dream most vividly; the students, being younger than the other men, have more vivid dreams. The power of remembering dreams is also dependent upon vividness and frequency of dreaming: it is accordingly greatest in women, and greater in students than in more mature men. The liveliness of the emotional nature, a prominent feature of women and youth, seems thus to be marked out as the causative agent in the production of dreams.

The duration of sleep should naturally be related to the habit of dreaming, but in the men no such relation can be discovered. In the women, however, it appears that those who dream frequently sleep nearly an hour longer than those who seldom dream. This difference is regarded as due to the fact that men are more under duty to break short their sleep, and thus vitiate the statistics. This is corroborated by the frequency with which the men who dream frequently declare themselves tired in the morning, indicating incomplete sleep. The need of sleep is greater in women than in men: the duration of sleep being longer, and the percentage of "tired morning and evening" and of "not tired" being 3 to 2 and 2 to 3 respectively as compared with the men. Students sleep longer, and are less tired, than other men.

The time needed to fall asleep is about the same in all three classes,

—20.8 minutes for the men, 17.1 minutes for students, and 21.2 minutes for women. In each case, however, it takes longer for those who are frequent dreamers and light sleepers to fall asleep than persons of opposite characteristics. Eighty per cent of students sleep uninterruptedly through the night, 70 per cent of other men, and only 43 per cent of women. Light sleep and frequent dreams increase the interruptedness of sleep.

The power of falling asleep at will is possessed by few. It is greater in youth than in age. Twenty-eight per cent of men, 19 per cent of students, and 20 per cent of women sleep in the afternoon, indicating a making-up of insufficient sleep on the part of the men.

The effect of dream-habits upon mental work is also evident. Those who dream seldom, or sleep deeply, are better disposed for work in the forenoon than light sleepers and frequent dreamers. The forenoon seems in general to be the preferred time of work.

The statistics regarding nervousness confirm the accepted fact that this is greater among women than men. It is greater among students than among men at large. It is, too, a concomitant of light sleep and frequent dreams. As to temperament, the phlegmatic people are quite constantly deep sleepers and infrequent dreamers.

Finally, a contrast between teachers and professors of the same average age shows the effect of occupation. The teacher, with his daily toil, has a lighter sleep and more frequent dreams; while the professor, leading a comparatively congenial and worryless life, is a deeper sleeper and a less frequent dreamer. This, perhaps, is related to the lack of visualizing power that Mr. Galton found to be current among men of science.

The relation between depth of sleep and frequency of dreams seems explicable on the supposition that the insensitiveness to outside excitations present in deep sleep, also induces insensitiveness to internal impressions. The threshold of mental life is raised. If the normal psychical activity is great, then, even in a deep sleeper, will the dreams be frequent, thus accounting for the exceptions.

In addition to the interesting results that this study has brought out, it increases one's sense of the utility of such inquiries, and shows the truth of Galton's experience, indorsed by the author, that "it is a much easier matter than I had anticipated to obtain trustworthy replies to psychological questions."

ETHNOLOGY.

Jade in Alaska.

LIEUT. G. T. Emmons, who is continuing his interesting researches in Alaska, recently made an interesting find at Sitka. He writes: "A boulder of jade was dug up on the site of the present Indian village, at a depth of some three feet in loose black soil. Two pieces have been cut from it for knives or adzes, each about

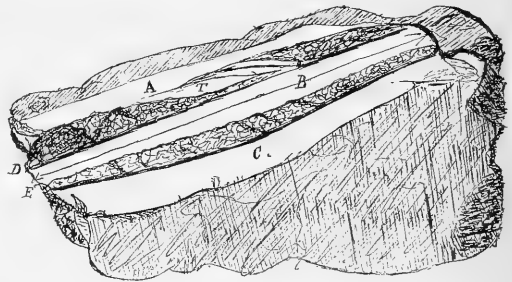

20 centimetres long, from 3 to 4 centimetres wide, and from 1 to 1.5 centimetres in thickness. The three faces on which the boulder has been cut are highly polished, and show a mottled green surface, ranging in color from a yellow green to a rich dark green. After the pieces were cut down on either side, they were broken from the body of the boulder by a shock, probably by means of a wedge. On another side, where a wedge-shaped adze could be re-

moved with the least work, a cut has been commenced, forming a somewhat irregular groove, following to some extent the irregular surface of the boulder. It is 12 centimetres long, and 0.2 of a centimetre deep. From inspection, I should say it had been worked by means of a stone knife or the edge of some silicious rock not having a cutting edge of more than 2 or 3 centimetres at the greatest. The whole boulder is wedge-shaped, and 29 centimetres in length. Its weight is a few ounces less than 20 pounds. The four faces are of olive green, the more prominent rounded surfaces being veined with a rich dark green. In my collection in the American Museum of Natural History there is a small nugget about the size of a hen's egg, with a groove in it; a dark green jade; and I have also in my possession a piece of unworked jade of a rich sea-green, which I found an Indian wearing as a scratcher. It has well-rounded edges and well-polished surfaces, proving long wear. Among forty-three pieces I have collected among the Tlingit, these are the only ones that show that jade has been worked on the spot. Jade has been used for implements, generally for adzes, axes, or fighting-picks, the last mounted in wooden handles."

The finding of this boulder of jade showing 'worked' surfaces is important, as it proves that the material was found and worked in southern Alaska. It will be remembered that Dr. G. M. Dawson found a boulder of the same description on the lower Fraser River, and that Jacobsen and Dawson found boulders of this material, although the rock has not been found *in situ*. Lieut. Emmons adds that he is very hopeful of finding the exact locality from which the Alaskan jade is obtained, as he received trustworthy information referring to this interesting question from the natives.

NAVAJO INDUSTRIES. — While in former years the "Proceedings of the United States National Museum" contained almost exclusively essays on zoological, botanical, and geological subjects, in the new volume, which is being issued in signatures, much attention is paid to ethnological points. To Professor Otis T. Mason's energetic endeavors we owe some interesting notes on the methods of manufacture among the Navajo, for Dr. Shufeldt's remarks on the method of preparing deer-skins by this people was written at his instance. The most interesting portion of this essay is the description of the process of tanning, which is done by means of a decoction of brains applied to the outer side of the skin after the hair has been removed. It is said that by this process the skin attains its softness and pliability. Mr. A. M. Stephen contributes some notes on the art of shoemaking and a myth explaining certain customs connected with this art. He tells that in olden times the Navajo used to wear grass shoes, until a deity came and taught them the art of making leather shoes. As this deity's face is gray, the Navajo must avoid looking at any thing gray, — for instance, the fresh-cut edges of a skin, — and therefore the latter must always be painted red, yellow, blue, or black.

BOOK-REVIEWS.

Elements of Machine Design. By J. F. KLEIN. Bethlehem, Penn., The Comenius Press. 8°. \$6.

Gear Tables for laying out Accurate Tooth Profiles. By J. F. KLEIN. Bethlehem, Penn., The Comenius Press.

IN this work, Professor Klein, who is professor of mechanical engineering at Lehigh University, treats of the most important of the machine parts that appear in practice, giving their proportions and the main considerations governing their use and construction. The work is not, nor does it claim to be, a complete treatise upon the subject of machine design, but it is a series of notes and plates specially arranged for students of machinery desiring practice in designing the commonly occurring machine forms, and is well adapted, in extent and character, to the requirements of technical schools. It contains much that is new, including a diagram and tables for determining the diameter of stepped-cone pulleys, extensive tables of co-ordinates for laying out toothed profiles, a determination of the cross-sections of connecting-rods, and a method of finding belt-widths from their specific duty.

Pains have evidently been taken to make the work convenient for

reference. The symbols used in the formulas are placed in alphabetical order at the beginning of each chapter, which consists of a plate with its accompanying notes; the formulas are numbered; and the index is very full, being divided into four columns, referring respectively to pages, formulas, figures, and tables. To insure durability, the plates and gear tables are printed on strong bond-paper.

The first five chapters of the book are devoted to fastenings, including bolts and nuts, rivets and riveted joints, keys, and gibs and cotters. Seven chapters treat of gearing, toothed and belt. Of the remaining chapters, one each is devoted to rotating pieces, bearings, connecting-rods, and gear tables.

That portion of the book devoted to gear tables has been issued in separate form, for the use of pattern-makers, machinists, draughtsmen, and students of engineering. The tables are printed on both sides of one large card, 17 by 20 inches, so as to get them into compact form for use in the shop, draughting-room, or college. The use of the tables is made clear by examples worked out in detail, and illustrated by suitably drawn figures.

The Secret Doctrine: The Synthesis of Science, Religion, and Philosophy. 2 vols. By H. P. BLAVATSKY. New York, William Q. Judge. 8°.

THE connection between this work and science can only be shown on the Hegelian principle of the identity of contradictories; for it has not a single characteristic of a scientific treatise. It is a pure fiction from beginning to end, — a work of imagination, pretending to give an account of the creation and evolution of the world, but without even an attempt at proof. The nucleus of the book consists of some passages alleged to be taken from the "Secret Book of Dzyan," which, the authoress tells us, "is utterly unknown to our philologists, or, at any rate, was never heard of by them under its present name." And in her preface she says, "The writer, therefore, is fully prepared to take all the responsibility for what is contained in this work, and even to face the charge of having invented the whole of it." The passages from the "Book of Dzyan" are followed by an elaborate commentary; and that they need it will be evident from the following extracts, which relate to the beginning of creation: "The eternal parent wrapped in her ever invisible robes had slumbered once again for seven eternities. . . . But where was the Dangma when the Alaya of the universe was in Paramartha, and the great wheel was Anupadaka? . . . The root remains, the light remains, the curds remain; but still Oeahoo is one;" and so on for many pages.

When we inquire more closely into Mrs. Blavatsky's doctrine, we find it at bottom pantheistic. She holds to the existence of "an omnipresent, eternal, boundless, and immutable Principle, on which all speculation is impossible, since it transcends the power of human conception." Sometimes, however, she speaks as if this first Principle was the same as Space, which she calls "the seven-skinned eternal Mother-Father." To trace the evolution of the universe and of man from this first Principle is the object of this work, and is pursued through over fourteen hundred octavo pages, with more to come. We cannot undertake to give even the shortest abstract of the work, which reads like the Hindu and Babylonian cosmologies; but those who wish to see what antics the human imagination is capable of may profitably consult these volumes. There is one item, however, to which we must call attention. It seems that this occult and incomprehensible doctrine is connected with the Keely motor. We are told that there is in the universe a mysterious force capable of reducing a whole army to atoms in a few seconds; and "this great *archæus* is now discovered by, and only for, one man, — Mr. J. W. Keely of Philadelphia." It appears, however, that Keely is not destined to succeed with his discovery, because it "would lead to a knowledge of one of the most occult secrets, — a secret which can never be allowed to fall into the hands of the masses." We are also informed that "the secret teachings with regard to the evolution of the universal Kosmos cannot be given, since they could not be understood by the highest minds in this age;" so that we shall have to content ourselves with what Mrs. Blavatsky may reveal to us. The extracts we have here given, which might have been multiplied indefinitely, will give our readers a general idea of her work, and will show that whatever may be the value of her "science, religion, and

philosophy," she has at least made a considerable contribution to humorous literature.

Healing Question. By SIR HENRY VANE. (Old South Leaflets. No. 6.) Boston, D. C. Heath & Co.

The Fundamental Orders of Connecticut. (Old South Leaflets, No. 8.) Boston, D. C. Heath & Co.

THESE little pamphlets relate to the beginnings of written constitutions. Vane's paper appeared at that time in the history of the English commonwealth when serious dissensions had arisen in what he calls "the honest party," and was written with the hope of settling the difficulty. It proposed the expedient, now so familiar but then first suggested, of a national convention to prepare a constitution of government by which both people and rulers should be bound. The proposal was not acted on by the people of England, but its appearance is an event of some importance in political history. The rest of the ideas in Vane's pamphlet are those commonly held by the leading patriots of his time; and the clumsy and intricate style in which they are expressed makes the work any thing but agreeable reading. The earliest written constitution, according to Mr. Mead, the editor of these "leaflets," is that adopted by the people of Connecticut in 1638; and this constitution, with the one adopted the next year by the colony of New Haven, is here reprinted. The New Haven document is largely ecclesiastical; the Church is dealt with as well as the State, all public officers are to be church members, and in the popular convention itself all questions are settled "by sundry arguments from scripture." The Connecticut constitution is more strictly political, and its historical distinction renders it well worthy of a place in this series of popular studies.

The Seventh Annual Report of the State Board of Health of New Hampshire. Manchester, State. 8°.

THIS report of the State Board of Health to the governor and council is evidence that the year ending April 30, 1888, was an unusually active one in the State of New Hampshire so far as concerns the details of sanitary administration. A greater demand was made for the services of the board by town authorities, local boards of health, and those in charge of public institutions. In addition to this, the advice of the board was sought in hundreds of individual cases and in all sections of the State. These facts are certainly very encouraging, and demonstrate that there is a growing interest, in this State at least, in the subject of sanitation. During the year the legislature enacted a number of important sanitary measures. One of the most important of these placed scarlet-fever and diphtheria among the dangerous pestilential diseases, and gave the board authority for their suppression. Greater powers were extended to health authorities throughout the State in respect to unsanitary dwellings and polluted water-supplies.

One of the most valuable results of the board's labors is that which has come from a sanitary supervision of the summer resorts of the State. The money left by summer visitors at the various resorts aggregates several hundred thousand dollars annually; it builds homes, schoolhouses, churches, and hotels; it increases the valuation of real estate, and in many ways adds to the material prosperity of the towns, villages, and cities. The board recognizes that this great interest should be carefully guarded against the only thing that can ruin it, — disease from neglected sanitation. In the furtherance of this policy, a sewer was constructed at Rye Beach. It conveys the sewage of ten or more of the largest hotels and boarding-houses to the ocean; it is two thousand feet in length, and ten inches in diameter. Its cost was three thousand dollars.

The public water-supply throughout the State has received careful attention. Several towns have constructed water-works, and in every such instance the health of the community has been notably improved. The improvement has been especially marked in the reduction of typhoid-fever.

In the report of 1887 the board gave, in a general way, a statement of the sanitary condition of nearly thirteen hundred school-houses in the State. The surveys of these schools revealed the fact that there was no system used in their construction, and that in a great majority the plans on which they were built were such as might be devised by a carpenter ignorant of architecture and

the requirements of scholars and teachers. These buildings are not ventilated, they are inadequately heated, badly lighted, furnished with a questionable water-supply, and surrounded by foul privies. The present report deals more in detail with these defects, particular attention being given to the schools of Portsmouth and Concord.

The health laws of the State being scattered through the session laws and passed by the various legislatures, great difficulty is experienced by local sanitary officials in determining just what the law is, in reference to any given subject. To obviate this, the board has made a compilation of all such laws, and has published them as an appendix to the present report. The index to the report is very complete. Taken as a whole, this report is a valuable contribution to sanitary literature, and furnishes additional argument for those who maintain that State boards of health should exist throughout the Union, so constituted as to be as permanent as possible, and independent of politics.

AMONG THE PUBLISHERS.

THE Open Court Publishing Company of Chicago announces the appearance within the present month of an important contribution to experimental psychology by the eminent French scientist, Alfred Binet. The work is entitled "The Psychic Life of Micro-Organisms," and is published with the sanction of the author, who has written a preface especially for the American edition. The essays forming the work appeared originally in the *Revue Philosophique* of Paris, and were afterwards published in part in *The Open Court*. The original cuts have been procured, and new plates and subsequent additions to the text have been incorporated in the work. The monograph of M. Binet is a presentation of the most important results of recent investigations into the world of proto-organisms. M. Binet has added much to the psychology of the microscopic world by these researches. He has opposed many theories, confirmed others, and advanced many conclusions founded upon his personal investigation. The subject is a branch of comparative psychology little known, and, as a rule, imperfectly understood. Psychologists, and all who are interested in questions of biology, will accordingly look forward to the work of M. Binet as a welcome light on the problem of life.

—Houghton, Mifflin, & Co. will publish, about March 1, an important economic work, "Profit-Sharing between Employer and Employee: A Study in the Evolution of the Wages System," by Nicholas P. Gilman (editor of the *Literary World*). It is the first comprehensive work on industrial partnerships in our language. Written in a popular style, Mr. Gilman's work is commended as "valuable from both the scientific and the practical points of view" by President F. A. Walker, Carroll D. Wright, R. T. Ely, and other high authorities. It will undoubtedly awaken wide interest as an instructive and candid discussion of one promising method for the solution of "labor difficulties."

—The February *Magazine of American History* again anticipates the popular desire, and comes, in honor of Washington's birthday, as a "Washington number." Those who are searching for data concerning Washington's presidential career in New York City will welcome Mrs. Lamb's leading article, "Washington as President, 1789-90," a companion piece to her "Inauguration of Washington in 1789," published in December. The frontispiece represents in a group, Washington, his wife and her two grandchildren, at the age and as they appeared in 1789. The copy of Huntington's great painting of "Lady Washington's Reception" fills two full pages, and the key another page. The house New York was building for President Washington also occupies a full page. The sensational feature of the issue, however, is the De Vries portrait of Washington, discovered in Holland the past summer by the Holland Society of New York, while on its pilgrimage there. Rev. Dr. J. Howard Suydam describes the find, and gives also a picture of De Vries, the owner of the portrait. The third article, by Gen. John Cochrane, presents an unpublished letter of Washington in facsimile, written to Hon. James Duane in 1780. The four articles that follow relate to other themes, — "A Canadian-American Liaison," by Watson Griffin of Montreal; "An Oriental Account of the

Discovery of America," by Alfred J. Hill of St. Paul; "The Mound-Builders and North American Indians, whence came They?" by Jacob Harris Patton, Ph.D.; and "Slavery in New York and Massachusetts," by John Carrick of Chatham, Ont. These are followed by several shorter papers on Washington, and curious and interesting Washingtonia in the various departments.

— Mr. Andrew Lang has followed his "Letters to Dead Authors" by letters about living authors, most of them contributed to the *Independent* during the past year or two. In one of these Mr. Lang pays higher praise to Longfellow than the American Poet has yet received from any English critic. These "Letters on Literature" will be issued here shortly by Longmans, Green, & Co. Under the title of "Colloquies on Preaching," the same firm are about to publish a little book by the Rev. H. Twells on the deficiencies of the modern pulpit. The form of this discussion is quite as unconventional as its suggestions. There are about a score of pertinent dialogues in the little volume.

— *The Voice*—not the *Prohibition* organ—has changed its name to *Werner's Voice Magazine*. It is a monthly devoted to the human voice in all of its phases for speech and for song. Edgar S. Werner, 28 West 23d Street, New York, is the owner and editor.

— Messrs. Frederick Warne & Co. announce that the next volume in their Cavendish Library will be "Leigh Hunt as Poet and Essayist," being the choicest passages from his works, selected and edited with a biographical introduction, by Charles Kent.

— John Wiley & Sons, New York, announce as in preparation "A Manual of the Steam-Engine," a companion volume to the "Manual of Steam-Boilers," by Professor Robert H. Thurston; "Steam-Engine Design," for the use of mechanical engineers, students, and draughtsmen, by Professor J. M. Witham; "A Laboratory Guide in Chemical Analysis," second edition, entirely rewritten and revised by Professor David O'Brine of Colorado State Agricultural College; "A Technical Dictionary," defining as an authority all the terms of art and industry, by Park Benjamin; "The Guide to Piece Dyeing," containing 100 samples of the author's own coloring, each sample accompanied with a recipe, by F. W. Reising, practical dyer and chemist; "A Treatise on Linear Differential Equations," by Professor Craig of Johns Hopkins University; "A Treatise on Masonry Construction,"—containing materials and method of testing strength, etc.; combinations of materials, composition, etc.; foundations, testing the bearing power of soils, etc.; masonry structure, stability against sliding, overturning, crushing, etc.,—complete in one volume of about 500 pages, with 125 illustrations and eight or ten folding plates, by Ira O. Baker, C.E.; "An Elementary Text-Book of Chemistry," by William G. Mixer, professor of chemistry, Sheffield Scientific School, Yale College, New Haven; "Notes in Thermo-Dynamics and Steam-Engine Experiments," by Professor C. H. Peabody, Massachusetts Institute of Technology; "A Treatise on Hydraulics," designed as a text-book for technical schools, and for the use of engineers, by Professor Mansfield Merriman; "Brackett's Elementary Treatise on Physics," abridged from Anthony and Brackett's "Text-Book of Physics;" "Differential Equations," a mathematical treatise, specially prepared with reference to a post-graduate course, by Professor W. W. Johnson; "Kinematics; or, Practical Mechanism," Part II.,—a treatise on the transmission and modification of motion and the construction of mechanical movements, for the use of draughtsmen, machinists, and students of mechanical engineering, in which the laws governing the motions and various parts of mechanics, as affected by their forms and modes of connection, are reduced by simple geometrical reasoning and their application is illustrated by accurately constructed diagrams of the different mechanical combinations discussed,—by Professor Charles W. MacCord, Stevens Institute of Technology; "Preparation of Organic Compounds," introduction to the preparation of organic compounds, by Dr. S. Levy of the University of Geneva, translated and revised by Professor P. T. Austen, Rutgers College, and New Jersey State Scientific School; "Flow of Water in Rivers and other Channels," by Ganguillet and Kutter, translated, revised, and extended by Rudolph Hering and J. C. Trautwine, jun.; and "A Grammar of the

Hebrew Language," greatly enlarged, and for the most part rewritten, by Professor W. H. Green, D.D., Princeton Theological Seminary.

— In the *St. Nicholas* for February, Noah Brooks's account of "The White Pacha" tells the narrative of Stanley's past achievements and probable whereabouts. The paper is illustrated by a striking portrait of the great explorer, and will give many of the older readers of the magazine their first clear idea of the state of affairs in Central Africa. A well-illustrated article upon Japan follows, and is contributed by Arthur L. Shumway; and this, with Mr. Alton's explanation of "The Routine of the Republic," makes up the list of the more instructive articles of the number.

— In *Outing* for February we note the following principal articles: "Sleighting," by Will. H. Whyte; and the second of the series of papers on "American College Athletics—Yale University," by Richard M. Hurd. This article is richly illustrated, as is the description of "A Russian Wolf-Hunt," by Tom Bolton. In addition, we note Charles Lee Meyers's account of the Jersey City Athletic Club; an entertaining description of "A Trip across Wyoming on Horseback," by L. P. Robie, illustrated by E. W. Deming; and "Herne, the Hunter," a tale of mountain life, by W. Perry Brown. The "Editorial Departments" are attractive, while the "Records" present the latest achievements of athletes in the different sports and pastimes.

— Assistant Superintendent N. A. Calkins of New York City, so well known by his books on "Object-Teaching," has in press a little volume for teachers on "Ear and Voice Culture," to be published by E. L. Kellogg & Co. of New York and Chicago.

— "Easy Experiments in Science," is the title of a little handbook by Professor J. F. Woodhull, formerly of the normal school at New Paltz, N.Y., to be published in February by E. L. Kellogg & Co., New York and Chicago.

— There is a timeliness in several of the articles in the February *Atlantic*. "The New Talking-Machines" is the subject of an article on the phonograph by Philip G. Hubert, jun. Charles Worcester Clark discusses "The Spirit of American Politics as shown in the Late Elections." A feature of this number is the address to the assembly at the opening of the new Players' Club in New York, by T. W. Parsons, which became the special property of *The Atlantic*, and which is now for the first time published. In sharp contrast with this witty and cheerful poem, Henry C. Lea writes on "Brianda de Bardaxi," describing one of the fiendish devices of torture devised during the time of the Inquisition; Agnes Repplier, one of the brightest essay-writers in America, contributes "A Plea for Humor;" Harriet Waters Preston, in an article entitled, "Under which King," paints in glowing colors certain passages in the life of Cicero; and Samuel H. Scudder finds a congenial topic in "Butterflies in Disguise." The prominent reviews are on the "Letters of Felix Mendelssohn," "Ancient Rome in the Light of Recent Discoveries" (the Lanciani book), and "Illinois Life in Fiction." Some rather quaint points are raised in "The Contributors' Club;" and "Books of the Month" is, as usual, readable and entertaining.

— It is worthy of note that editions of every important book published here by Charles Scribner's Sons in the past season have been printed in England.

— The Travellers' Insurance Company will publish at once, in five octavo volumes, a uniform edition of the works of Walter Bagehot, the economist.

— Macmillan & Co. will shortly publish an American novel on the subject of divorce, entitled "Faithful and Unfaithful," by Miss Margaret Lee.

— The Forest and Stream Publishing Company announces "Sam Lovel's Camps," a sequel to "Uncle Lisha's Shop," by Rolwand E. Robinson. It is descriptive of Vermont life and character forty years ago.

— C. Wellman Parks, of the Rensselaer Polytechnic Institute, Troy, N.Y., has undertaken the preparation of an exhibit of American periodicals for the Paris Exposition of 1889, and requests all interested to help him make it complete and worthy.

LETTERS TO THE EDITOR.

Indian Relics from North Carolina.

DURING the past summer the writer was one of a party who tramped through the mountains of western North Carolina for a month. The country was extremely rough, and we were somewhat surprised at the exceeding abundance of Indian relics. Arrow-heads were found almost everywhere, and we often picked them up even in the roads. There was hardly a mountaineer to be found who had not at least a hatchet or a scraper, and often a native would come in smoking a pipe he had found in his cornfield. The favorite material for the pipes and scrapers was soapstone. Some of the former resembled in shape the common clay-pipe bowl;

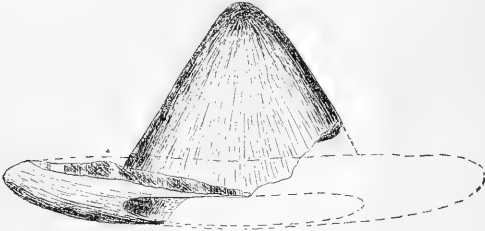

FIG. 1.

and it is possible that such are recent, for it is not more than forty or fifty years since the Cherokees roamed over all that region. Still we saw none such among the Indians on the Reservation, and of many of the relics they know as little as we. The hatchets were of a variety of materials, and none of them highly polished.

In almost every cornfield the soil was filled with fragments of pottery, some solid and showing marks of fire, others crumbling to dust. One could pick up pieces by the thousand, and not one could be found which did not show some form of ornamentation. All the designs were geometrical figures formed by combinations of straight lines and curves, both circular and spiral. The edges of the vessels seemed in some to be plain, and in others raised and scalloped or notched. None were found showing any traces of

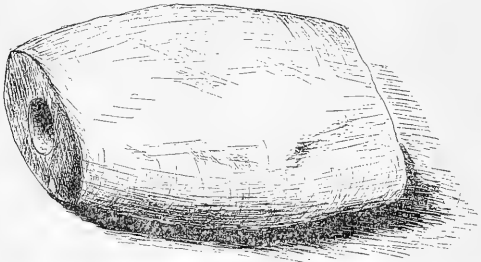

FIG. 2.

handles, or any lines of chafing from cords. The designs were evidently made with a sharp point while the clay was soft. The Cherokees still make much of their own pottery, but it is rude, and as a rule unornamented.

We ran across several specimens which puzzled us. One, which is represented in Fig. 1, was shown to us by the owner of a gold-mine near Cashiers Valley, Jackson County. It was washed out in the gravel. We were permitted to make a drawing of it. It is neatly cut from a greenish soapstone, and is quite smooth. It is badly broken, but the apparent form is indicated by the dotted line. It resembles somewhat one of the old-fashioned sugar-loaf hats, and is neatly hollowed out on the inside. Nearly in the middle of the side, as will be seen from the drawing, is a small hole drilled through the stone. We could think of no possible use for such an implement.

Another interesting one, found in a field near the Nautehala Mountains, in Macon County, is shown in Fig. 2. It is an oval block of soapstone, with perfectly flat ends, and has in one end a

neatly cut circular hole 1.5 centimetres in diameter, and 2.3 centimetres deep. The length of the specimen is 9.7 centimetres, and its greatest breadth 8.5 centimetres. The surface is comparatively smooth, but no attempt seems to have been made to polish it. It is now in the possession of the writer, who would be glad to receive any information as to its use.

The only mound we saw is close to the town of Franklin, the county seat of Macon County. This stands on the bottom-lands, not far from the Tennessee, and is well preserved. It is an oval truncated cone; and we estimated the greatest diameter of the base at seventy-five feet, and its height at twenty feet. We heard of another on the road from Charleston to the Indian Reservation at Yellow Hill, but failed to find it. Beads, arrow-points, pottery, and other relics, are often ploughed up near these mounds, but the limited time at our disposal prevented any very thorough exploration.

L. N. JOHNSON.

Evanston, Ill., Jan. 19.

The Characteristic Curves of Composition.

I WAS intensely interested in the article *Science* published more than a year ago, by Professor Mendenhall, on style curves, and made up my mind to submit the Bacon-Shakespeare question to a style-curve test at once. But somehow it was only last week that I

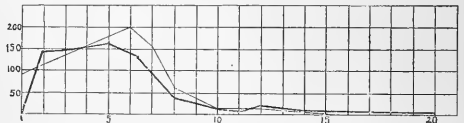

got at it. I enclose you the result. The light line is Bacon; the heavy, Shakespeare.

In order to understate it, if possible, I selected the Shakespeare from Oliver's speech (*Twelfth Night*, II. i. 110), — a passage almost as sententious as Bacon's acknowledged work; and the Bacon from his "Essay on Youth and Age." APPLETON MORGAN.

New York, Jan. 10.

The Permian Rocks of Texas.

As it is evident that the question of the occurrence of Permian strata in America will again be raised at an early day, and that generalizations will be based upon the as yet little studied Texas region, it may be in order to state that we have here a great series of beds, beginning west of the 97th meridian, and succeeding the carboniferous; and beneath the undoubted Wealdan beds of the cretaceous, a great development of strata, the lower half of which cannot possibly be referred to any other age than the Permian, although the upper portion is probably triassic. Professor Cope has long since described the vertebrates of these Permian beds; and the *Mollusca*, I am informed, are now being examined. The stratigraphy, however, has as yet only been reconnoitred, and no section whatever determined. The writer, however, made two journeys across the region into New Mexico last summer, to observe the problem, and was impressed with a fact which should be borne in mind in future discussions of the region. The stratigraphic features agree, as far as could be seen, in nearly every generality with those of the Kanab Valley of Utah as described by Mr. C. D. Walcott, a few years ago, in the *American Journal of Science*, and were the direct eastward continuation of the same. Not only does this similarity agree with the Permian beds, but with the upper beds, which he calls triassic. This connects the Grand Cañon and Texas Permian-triassic basin beyond all doubt; and to Mr. Walcott belongs the credit of the first and only intelligible section of the American Permian, a most marked and unmistakable terrain, the discovery of which was made, as agreed, by Professor Jules Marcou. This fact, together with the distinct basin type of structure of the trans-Pecos region, to which I have recently called attention, and the determination of many distinctly western geographic features extending two-thirds the way across Texas, makes this State pre-dominantly western, although its eastern third is within the limit of the timber-covered southern coastal plain.

ROBT. T. HILL.

Austin, Tex., Jan. 21.

MAX O'RELL'S
IMPRESSIONS OF AMERICA.
**JONATHAN
AND
HIS CONTINENT**

RAMBLES THROUGH AMERICAN SOCIETY
BY
MAX O'RELL,

Author of
"John Bull and His Island," "John Bull, Jr.,"
etc., etc., and
JACK ALLYN,

Translated by Madame PAUL BLOUET.
In one elegant 12mo volume. Price, \$1.50.
Max O'Rell, in this volume of impressions of
America and the Americans, gives us the brightest
and best work he has yet done. While often severe,
he is always kind. Altogether the book is very
lively reading and will unquestionably excite the
interest of every American citizen who wants to
know what a keen-eyed, intelligent, and witty
Frenchman has to say of him and of his country.

Complete Catalogue of publications sent free to
any address on application.

CASSELL & COMPANY, Limited,
104 & 106 FOURTH AVENUE, NEW YORK.

STEADFAST.
By ROSE TERRY COOKE, author of "Some-
body's Neighbors," "The Deacon's
Week," etc. \$1.50
"This story is one of Mrs. Cooke's masterpieces.
Just at this time, in the excitement of discussion
brought about by Robert Elsmere" and John Ward,
Preacher, "I think 'Steadfast,' with its treatment of
the old Orthodox question in the old days, backed
as it is by history, will come in on the side of inter-
est, with a new flavor, which must lead on to popu-
larity."—NORA FERRY.

GREAT CAPTAINS.
By Col. THEODORE AYRAULT DODGE, U.S.A.
Six Lectures before the Lowell In-
stitute, Boston, in 1889. 8vo. With
21 maps. \$2.00

"ALEXANDER, HANNIBAL, CESAR, GUS-
TAVUS ADOLPHUS, FREDERICK, NAPOLEON,
and the record of their achievements, and the analy-
sis of what each of them contributed to military
science. Colonel Dodge has been a comprehensive
and profound student of the art of war as illustrated
in the careers of the great captains of history, but I
apprehend that no man in this country has laid a
broader or deeper foundation for his treatment of
this interesting theme."—TAYLOR, in Boston Post.

**ANCIENT AND MODERN LIGHT-
HOUSES.**

By MAJOR D. P. HEAP, U. S. A. Square
8vo. With 100 illustrations. \$5 00
Indispensable to all Architects and Engineers.

**HAND - BOOK OF CHRISTIAN
SYMBOLS.**

By CLARA ERSKINE CLEMENT and KATH-
ERINE E. CONWAY. 12mo. Cheap
edition \$1 50

Sold everywhere. Sent, postpaid, on receipt of price
from the Publishers,
TICKNOR & CO., Boston.

A TEMPORARY BINDER
for Science is now ready, and will be mailed
postpaid on receipt of price.



Cloth - - 50 cents.
Half Morocco - 75 cents.

This binder is strong, durable and
elegant, has gal side-file, and allows
the opening of the pages perfectly
flat. Any number can be taken out
or replaced without disturbing the
others, and the papers are not mutilated
for subsequent permanent bind-
ing. Filled in this binder, Science is
always convenient for reference.

N. D. C. HODGES,
47 Lafayette Place, New York.

Theatres.
BROADWAY THEATRE. Corner 41st St.
MANAGER..... MR. FRANK W. SANGER.
LITTLE LORD FAUNTLEROY.
Evenings at 8. Mat. Sat. at 2.
LYCEUM THEATRE. 4th Av. and 23d St.
Daniel Frohman..... Manager.
SWEET LAVENDER.
MADISON SQUARE THEATRE.
Mr. A. M. Palmer..... Sole Manager.
CAPTAIN SWIFT.
PALMER'S THEATRE. B'way and 30th St.
MRS. POTTER.
Scale of prices, \$2, \$1.50, \$1, and 50 cents.

WEBSTER

THE BEST INVESTMENT
for the Family, School or Professional Library.

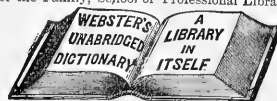

Besides many other valuable features, it contains

A Dictionary
of 118,000 Words, 5000 Engravings,
A Gazetteer of the World
locating and describing 25,000 Places,
A Biographical Dictionary
of nearly 10,000 Noted Persons,
A Dictionary of Fiction
found only in Webster,
All in One Book.

3000 more Words and nearly 2000 more illustra-
tions than any other American Dictionary.
Sold by all Booksellers. Pamphlet free.
G. & C. MERRIAM & CO., Pub'rs, Springfield, Mass.

SCHOOLS AND COLLEGES
will have a positive advantage by ordering their furniture
apparatus and supplies from
C. PARDO & CO.,
31 East 17th St., New York.

Scientific Apparatus.

J. GRUNOW,

621 Sixth Avenue, New York.
Established 1852.

MAKER OF

Microscope Stands,
Oil Immersion Object-
ives and Abbe Con-
densers for Bacterial
and Histological work,
of Objectives, Camera
Lucida and other ac-
cessory apparatus.

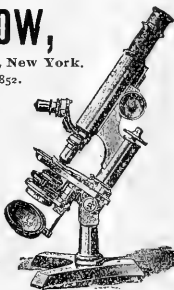

**IMPROVED OIL LIGHT
MAGIC LANTERNS.**

Also Lime and Electric Light Apparatus, and
mechanical, plain, and fine colored views.

J. B. COLT & CO., Manufacturers,
No. 16 BEEKMAN STREET, NEW YORK.

**WHITALL'S PLANISPHERES OF THE
STARRY HEAVENS** name and locate all
Planets, Stars, and Constellations visible at
any given minute of time. Every one should
possess set, \$5.00; Miniature, 50 cents postage paid.
Ask stationer, or address Wm. T. Cooper,
Manager, 307 Race St., Philadelphia, Pa.

MAGIC Stereoscopes and the Best Views
for Public, Church, Home, and
LANTERNS Scientific Exhibitions. Best ap-
paratus, new views. Largest stock. Reduced prices. 34
Years' Practical Experience. Illus. Catalogue Free.
GEO. H. PIERCE,
136 S. Eleventh St., Philadelphia, Pa

Micro sections of bone and teeth for the use
of colleges and students. Price list on applica-
tion. **F. O. Jacobs,** Newark, Ohio.

W. H. WALMSLEY & CO.
SUCCESSORS TO
R. & J. BECK,

1016 Chestnut Street Phila
**Microscopes and all
Accessories and Ap-
paratus. Photograph-
ic and Photo-Micro-
graphic Apparatus and
Outfits.**

**Spectacles, Eye
Glasses, Opera and
Marine Glasses, etc.**
Illustrated Price List
mailed free to any ad-
dress. Mention SCIENCE
in corresponding with us.



**GET THE NEW
ACME No 5
MICROSCOPE**

Complete, with high-class
lenses, 1 in. and 1-5 in.
\$28.00.

Send for complete catalogue
with a sample of The Micro-
scopical Bulletin.

JAMES W. QUEEN & CO.
Makers of the Acme Microscopes,
924 Chestnut St., Phila.



ZOOLOGY, ANATOMY, PALEONTOLOGY.—Large stock
of Vertebrates and Invertebrates.—We arrange and fur-
nish complete collections for educational purposes and
exhibitions in any of all departments of Zoology. We
have an immense stock of recent shells and fossils, es-
pecially from the tertiary period; anatomical preparations;
models (made of paper mache) of the human body, divisible,
complete, and in separate parts, also separate parts
of mammals, very important for the study of anatomy;
also microscopical preparations. **Linnæan Institution for
Natural History, Berlin, Germany.** Our Agent in the
U. S., **MR. HERMAN ROLLE, 33 Ave. A, New York City,**
will send specimen catalogues free on application.

Arnold,
Constable & Co.
SILKS.
INDIA PONGEES
AND
CORAHs.
Unrivalled for Durability & Wear.
Spring Styles show great novelty of
color and design.
Broadway & 19th St.
New York.

BLACK SILKS.
We are receiving large importations of Black Peau de Soie Silks, from \$1 to \$2.50.

Genuine Peau de Soie possesses Softness and Richness of appearance, in a greater degree than any other make of Dress Silk. It is also very durable. The prices marked by us are considerably less than manufacturers ask.

This is especially worthy of your attention. Write for samples.

JAMES McCREERY & CO.
BROADWAY AND ELEVENTH STREET,
NEW YORK.

Insurance.

DELAY IS DANGEROUS.

We call attention to the new form of Accident (indemnity) Insurance policies, which are written by the Merchant's Casualty Insurance Association, 21 Park Row, New York City. John S. Purdy, Secretary. These policies cover weekly allowances of from \$10 to \$25, according to occupation, at a cost of only \$6 a year exclusive of the cost to join, which is \$5 payable once only. The public, as a rule, carry life insurance, and the ordinary accident policies issued by companies, paying a sum in case of death, is not so desirable as one of these indemnity policies in case of accidents, which are so plentiful in this fast age with its railroad horrors, fast driving, electric wires and other countless forms of danger which the public is constantly exposed. The fact of the Association having no unpaid claims, and its having just passed an examination by the Insurance Department of New York State, shows that the management is liberal with its policy-holders and conservative in its action. The Association also desires to secure energetic Agents in every village and town, to whom territory and favorable terms will be given.

THE GREAT AMERICAN TEA COMPANY
GOOD NEWS TO LADIES.
Greatest inducements ever offered. Now's your time to get up orders for our celebrated Teas and Coffees, and secure a beautiful Gold Band or Moss Rose China Tea Set, Dinner Set, Gold Band Moss Rose Toilet Set, Watch, Brass Lamp, or Webster's Dictionary. For address **THE GREAT AMERICAN TEA CO.** P. O. Box 289. 31 and 33 Vesey St., New York.

Sprague Electric Railway and Motor Company.

For Stationary or Railway Work,
for Mining or Engineering
operations the SPRAGUE MOTORS
are unexcelled.

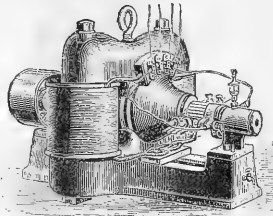

Estimates given for complete
Power Installations.

Send for Circulars and full
Information.

16 and 18 BROAD STREET, NEW YORK.

ELECTRICAL TESTING BUREAU,

Johns Hopkins University, Baltimore, Md.

Resistance Coils, and Boxes Compared.
Am meters and Volt meters calibrated.
Condensers standardized.
Primary and Secondary Batteries Tested.
Efficiency of Dynamos and Motors Determined.
Insulation of Cables and Wires Tested.
Etc., Etc.
Circulars describing Methods Used, Prices, Etc., sent on Application.
Address as above.

Schools.

CONNECTICUT, NEW HAVEN.

MRS. CADY'S SCHOOL FOR YOUNG LADIES. Prepares for Smith and Wellesley, and admits to Vassar by Certificate. Circulars. Early application necessary.

VERMONT, BURLINGTON.

VERMONT EPISCOPAL INSTITUTE. Boarding School for Boys. Prepares for College or Business. Military drill. Terms moderate. Fifty-seventh half-year opens September 3, 1888. Send for catalogue.
H. H. ROSS, A.M., Principal.

R. ELLIS & CO.

BUSINESS, HOTEL AND PATENT BROKERS,
AUCTIONEERS, ETC.

No. 176 BROADWAY,

Room 46.

New York.

CLIENTS Advised free of charge.

Wants.

WANTED.—A teacher for the Natural Sciences and History, who is also competent for the position of Associate Principal, in a flouri-ning private school. Address P. O. Box 385, Plainfield, N.J.

A Harvard graduate desires engagement as teacher of higher English branches, such as composition, rhetoric, literature, history, political economy, mathematics.

Address J. B. H.,

SCIENCE office.

TO EMPLOYERS.

Having purchased the fixtures, good will, &c., of the **NEW YORK EMPLOYMENT BUREAU**, at No. 681 BROADWAY, in this city, we request the patronage of the public in the future. We desire to fill a long-felt want for an employment bureau, where only the best grade of male help is dealt in, and it is our aim to send ONLY such help as is ordered in every instance, and our patrons can rely on us to send strictly first-class help, the references of whom we personally investigate before sending to any one. We simply request a trial, and are convinced that we will give satisfaction in every case. We have on hand help in every branch, which we can send upon receipt of telegram or letter, AND FOR WHICH WE MAKE NO CHARGE TO AN EMPLOYER.

NEW YORK EMPLOYMENT BUREAU,

(AS REORGANIZED).



**KIMBALL'S
STRAIGHT CUT
CIGARETTES.**

Unsurpassed in quality.
Used by people of refined taste.
Highest award at Brussels, 1888.
The finest smoking mixtures are of our manufacture.
Fifteen First Prize Medals.
WM. S. KIMBALL & CO
Rochester, N.Y.

Readers of Science

Corresponding with or visiting Advertisers will confer a great favor by mentioning the paper.



SCIENCE

SEVENTH YEAR.
VOL. XIII. No. 314.

NEW YORK, FEBRUARY 8, 1889.

SINGLE COPIES, TEN CENTS.
\$3.50 PER YEAR, IN ADVANCE.

D. APPLETON & CO.

HAVE JUST PUBLISHED

I.

The Development of the Intellect.

OBSERVATIONS CONCERNING THE MENTAL DEVELOPMENT OF THE HUMAN BEING IN THE FIRST YEARS OF LIFE. By W. PREYER, Professor of Physiology in Jena. Being Part II of "The Mind of the Child." Volume IX of "The International Educational Series," edited by W. T. Harris, LL.D. 12mo, cloth. Price, \$1.50.

"The Senses and the Will," Volume VII of "The International Education Series," constitutes Part I of "The Mind of the Child." Uniform with above and at same price.

II.

Nature and Man.

ESSAYS, SCIENTIFIC AND PHILOSOPHICAL. By the late WILLIAM BENJAMIN CARPENTER, M.D., F.R.S. With an Introductory Memoir by J. ESTLIN CARPENTER, M.A., and a Portrait. Large 12mo, cloth. Price, \$2.25.

In this volume a number of Dr. Carpenter's later essays have been collected, bearing on man's interpretation of Nature, and of his own consciousness. A few passages from earlier writings have been prefixed to illustrate some of the prior stages of his labors on physiological psychology.

I, 3, & 5 BOND STREET, NEW YORK.

THE

American Bell Telephone COMPANY.

95 MILK ST., BOSTON, MASS.

This Company owns the Letters Patent granted to Alexander Graham Bell, March 7th, 1876, No. 174,465, and January 30, 1877, No. 186,787.

The Transmission of Speech by all known forms of ELECTRIC SPEAKING TELEPHONES infringes the right secured to this Company by the above patents, and renders each individual user of telephones, not furnished by it or its licensees, responsible for such unlawful use, and all the consequences thereof and liable to suit therefor.

Wants.

WANTED.—A teacher for the Natural Sciences and History, who is also competent for the position of Associate Principal, in a flourishing private school. Address P. O. Box 385, Plainfield, N.J.

ON SALARY AND COMMISSION A CANVASSER for Subscriptions to *Science*.

39TH ANNUAL STATEMENT

OF THE

ÆTNA

Life Insurance Co.,

OF HARTFORD, CONN.,

JANUARY 1, 1889.

Premium Receipts in 1888.....	\$3,404,964 16
Interest Receipts in 1888.....	1,730,120 97
Total Receipts during the year.....	5,135,085 13
Disbursements to Policy holders, and for expenses, taxes, &c.....	4,045,408 26
Assets January 1, 1889.....	33,819,034 97
Total Liabilities.....	28,252,979 73
Surplus by Ct., Mass., and N. Y. standard.....	5,566,055 24
Surplus by many States.....	7,325,000 00
Policies in force January 1, 1889, 67,749, insuring.....	102,904,303 44
Policies issued in 1888, 8,083, insuring.....	16,094,587 00

MORGAN G. PULKELEY, President.

J. C. WEBSTER, Vice-President.

J. L. ENGLISH, Secretary.

H. W. Str. JOHN, Actuary.

GURDON W. RUSSELL, M.D., Consulting Physician.

Mumford & Bushnell Managers,

165 BROADWAY,

NEW YORK.

JUST PUBLISHED.

498 Pages, 12mo, Cloth. Illustrations and Plates. Price \$4.00.

THE TELEPHONE.

BY WM. HENRY PREECE, F.R.S., AND JULIUS MAIER, PH.D.

CONTENTS.

INTRODUCTION—CHAPTER I. SOUND AND SPEECH.
CHAPTER III. INDUCTION.
CHAPTER III. THE BELL TELEPHONE.
CHAPTER IV. CARBON TRANSMITTERS.
CHAPTER V. THEORY.
CHAPTER VI. TELEPHONE RECEIVERS.
CHAPTER VII. CARBON TRANSMITTERS.
CHAPTER VIII. SPECIAL TELEPHONES.
CHAPTER IX. ON THE COMPARATIVE EFFICIENCY OF SOME TRANSMITTERS.
CHAPTER X. TELEPHONE WIRE.—A—AIR LINES.
CHAPTER XI. AUXILIARY APPARATUS USED IN THE INSTALLATION OF TELEPHONE STATIONS.
CHAPTER XII. ORDINARY TERMINAL STATIONS.
CHAPTER XIII. INTERMEDIATE STATIONS.
CHAPTER XIV. TELEPHONE EXCHANGES. THE BRITISH POST-OFFICE SYSTEM.
CHAPTER XV. TELEPHONE EXCHANGES. THE GERMAN SYSTEM.
CHAPTER XVI. TELEPHONE EXCHANGES. THE FRENCH SYSTEM.
CHAPTER XVII. TELEPHONE EXCHANGES. THE SWISS SYSTEM.
CHAPTER XVIII. TELEPHONE EXCHANGES. MISCELLANEOUS.

CHAPTER XIX. TELEPHONE EXCHANGE MULTIPLE SWITCHES. THE WESTERN ELECTRIC MULTIPLE SWITCHBOARD.
CHAPTER XX. TELEPHONE EXCHANGE MULTIPLE SWITCHES. MANCHESTER EXCHANGE SYSTEM.
CHAPTER XXI. INTERCOMMUNICATION BETWEEN TWO DISTANT TELEPHONE NETWORKS. SYSTEM OF TRANSLATION.
CHAPTER XXII. PUBLIC TELEPHONE STATIONS.
CHAPTER XXIII. AUTOMATIC CONNECTION REGISTER FOR TELEPHONE EXCHANGES, ETC.
CHAPTER XXIV. MULTIPLE AND LONG-DISTANCE TELEPHONY.
CHAPTER XXV. SEVERAL SUBSCRIBERS PLACED ON ONE CIRCUIT (i).
CHAPTER XXVI. SEVERAL SUBSCRIBERS PLACED ON ONE CIRCUIT (ii).
CHAPTER XXVII. SEVERAL SUBSCRIBERS PLACED ON ONE CIRCUIT (iii).
CHAPTER XXVIII. APPLICATION OF THE TELEPHONE TO THE TELEGRAPH SERVICE.
CHAPTER XXIX. THE TELEPHONE AS A MILITARY INSTRUMENT.
CHAPTER XXX. MISCELLANEOUS APPLICATIONS.
APPENDIX THE TELEPHONE IN LONDON. CABLES. BRITISH WIRE GAUGE. INDEX.

** Copies sent postpaid on receipt of price.

D. Van Nostrand Company, 23 Murray & 27 Warren Sts., N.Y.

GUARANTY INVESTMENT COMPANY

CAPITAL \$250,000.

Hon. ALBERT H. HORTON (Chief Justice, Kansas Supreme Court), Topeka, Kan., Pres't.

7% Guaranteed Farm Mortgages 7%

The Company calls the special attention of Investors to the following points :

- I. All loans guaranteed and interest payable semi-annually at the Importers' & Traders' National Bank, New York.
- II. Unusual fulness of information, not only about the security itself, but about the general development of the section where the farm is located.
- III. An examination each year of the general business of the Company and the Mortgages themselves by a COMMITTEE OF INVESTORS sent for the purpose.
- IV. Many hundred Mortgages taken and NOT A SINGLE FORECLOSURE.
- V. Exhibitions in New York at frequent intervals, of Kansas and Nebraska Farm Products. The Exhibition at the American Institute in the fall of 1888, received the *HIGHEST AWARD* of superiority.
- VI. Monthly Bulletins giving full information about all Mortgages offered for sale.

Address for Monthly Bulletin and Investors' Committee Report for 1888,

HENRY A. RILEY, General Eastern Manager, 191 Broadway, N.Y.

Inducements in Dress Goods

Previous to the opening of our Spring Novelties we have marked several lines of desirable all-wool fabrics as follows :

- 3,250 yards plain and striped Beiges, 50cts.; reduced from \$1 per yard.
- 1,200 yards plain suiting, 65cts.
- 2,500 yards Herring Bone Stripes at 75 cts., regular price, \$1.25.
- 1,600 yards invisible Plaids, 85cts. per yard, 54 inches wide; well worth \$1.25.
- 1,450 yards illuminated Checks, 54 inches wide, at \$1; good value for \$1.50.

Samples of these or any other Dress Goods sent promptly on application.

JAMES McCREERY & CO.
BROADWAY AND ELEVENTH STREET,
NEW YORK.

ESTABLISHED 1859.

H. A. DREW,
Commercial Printer,
5 Clinton Place, near Broadway,
New York.

Wedding Orders, Souvenirs, Invitations, Orders of Dance, etc., etc., done in the latest and most elaborate styles, at reasonable prices.
All Favors promptly attended to.

KNABE

PIANOFORTES.

UNEQUALLED IN

Tone, Touch, Workmanship and Durability.

WILLIAM KNABE & CO.

NEW YORK: No. 112 Fifth Av., above 16th St.
BALTIMORE: Nos. 22 and 24 E. Baltimore St.
WASHINGTON: No. 817 Market Space, Penn. Av., near 9th St.

ESTERBROOK'S STEEL PENS.

OF SUPERIOR AND STANDARD QUALITY.

Leading Nos.: 048, 14, 130, 135, 239, 333

For Sale by all Stationers.

THE ESTERBROOK STEEL PEN CO.,

Works: Camden, N.J. 26 John St., New York.

Old and Rare Books.

A. S. CLARK, Bookseller,

34 PARK ROW, NEW YORK CITY.

A Gleaner in the By-ways of Literature. Results of Gleaning found in Catalogues issued from time to time.

CATALOGUE NO. 27 NOW READY.

BACK NUMBERS and complete sets of leading Magazines. *Revue, law.* AM. MAG. EXCHANGE, Schoharie, N.Y.

H. WILLIAMS,

Dealer in Old Magazines, Reviews, &c. Scientific periodicals a specialty. 39 Macdougall St., N.Y.

Readers of Science

Corresponding with or visiting Advertisers will confer a great favor by mentioning the paper.

FOOD ADULTERATION

And its Detection. With photomicrographic plates and a bibliographical appendix. By J. P. Battershall. 328 pages, 8vo, cloth. Price, \$3.50. Circulars and Catalogues on application. E. & F. N. SPON,
12 Cortlandt St., New York.

What Scott's Emulsion Has Done!

Over 25 Pounds Gain in Ten Weeks.
Experience of a Prominent Citizen.

THE CALIFORNIA SOCIETY FOR THE
SUPPRESSION OF VICE.
SAN FRANCISCO, July 7th, 1886.

I took a severe cold upon my chest and lungs and did not give it proper attention; it developed into bronchitis, and in the fall of the same year I was threatened with consumption. Physicians ordered me to a more congenial climate, and I came to San Francisco. Soon after my arrival I commenced taking Scott's Emulsion of Cod Liver Oil with Hypophosphites regularly three times a day. In ten weeks my avoirdupois went from 155 to 180 pounds and over; the cough meantime ceased. C. R. BENNETT.

SOLD BY ALL DRUGGISTS.

SCIENCE

FRIDAY, FEBRUARY 8, 1889.

THE THORNE TYPE-SETTING MACHINE.

It is nearly ten years since Mr. Joseph Thorne invented the type-setting machine bearing his name. This machine, as now manufactured by the Thorne Machine Company of Hartford, Conn., modified by the improvements suggested during several years' act-

der. The types, before distribution, are arranged in vertical channels in the upper cylinder, where they rest upon their sides. The distributing-cylinder revolves with an intermittent motion, thereby causing its channels at each step to coincide with and rest directly over similar channels in the setting-cylinder, which remains stationary.

Ordinary fonts of type are used, but each character has distinctively arranged notches, with which correspond wards at the upper

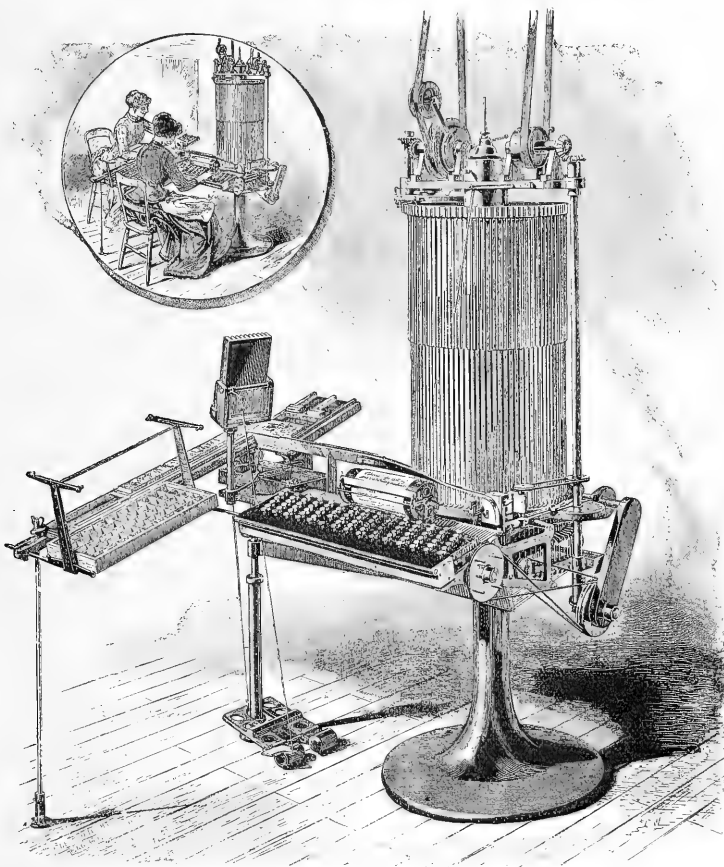

THE THORNE TYPE SETTING AND DISTRIBUTING MACHINE.

ual use in type setting and distributing, is shown in the accompanying engraving. This machine is now doing good service in book and newspaper offices in this country and Europe. Its working, as seen by a representative of *Science* a few days ago in an office in this city, where several of them have been in use some years, leaves little to be desired in the way of rapid and accurate distribution and composition.

The machine consists of two iron cylinders, mounted vertically one above the other upon the same axis. The upper one of these two is the distributing-cylinder, and the lower one the setting-cylinder

of each channel in the setting-cylinder; so that a type of a given character can only fall into its own proper groove in the latter. In these grooves the types rest on a bottom plate. The types in the distributing-cylinder are in the order they come from the forms; but by the step-like motion of the cylinder, and the action of the wards in the channels of the setting-cylinder, the types are automatically sorted, so that each channel of the stationary cylinder contains only types of the same kind.

Composing is effected from a keyboard like that of a type-writer, on a somewhat larger scale. By the depression of any key, through

an arrangement of levers and rods, the lowest type in the corresponding groove of the composing-cylinder is pushed radially outwards on to a very rapidly revolving disk, which carries it to an opening in the stationary guard surrounding the disk, and delivers it upon a moving belt, on which the types are carried in their proper order to a revolving lifter, which raises them in succession into a long setting-stick in front of the operator, terminating in a justifying-stick at the upper end of an inclined channel or galley.

In justifying, a section of the composed line of type is drawn to the mouth of the justifying-stick, and is justified with spaces taken from a case containing channels for the different spaces and the hyphen, the lowest of which are pushed partially out by ejectors worked with a treadle.

The lines of type, when ready for distribution, are inserted in the grooves of the distributing-cylinder from a special galley by means of a slide, with which a whole line at a time is pushed bodily into a groove.

It is claimed that this machine will distribute and set at the rate of six thousand ems per hour, doing, with three persons, the work of six men working in the ordinary way. Considering the purpose for which the machine is intended, the construction is simple, and there appears to be no difficulty or hitch in the working.

It should be remarked, that, by manipulating the keys in one direction only, several keys may be touched simultaneously without risk of the characters becoming transposed. In working the opposite way, each key must be touched separately. The machine is driven from a shaft by two small belts. One belt transmits motion to the revolving disk below the type-setting cylinder and to the type-lifter; while the other belt, by means of a tightening-pulley and ratchet-gear, produces the step-by-step motion of the distributing-cylinder.

THE STEAM-ENGINE, ITS PRINCIPLES, ITS DEVELOPMENT, ITS PRESENT CONDITION, AND ITS FUTURE PERFECTION.¹

In this lecture will be found, stated in a very compact form, the fundamental principles of the steam-engine, and a history of its development. Some of the statements at first glance seem very startling, but they are so supported by the records that surprise is overcome by conviction. One of these statements is, that "for a generation after James Watt's death the art of producing power from fuel by the intervention of a steam-engine retrograded; so that less power was usually obtained from a pound of coal consumed than had been obtained by the use of methods invented and fully explained by James Watt."

This is illustrated by the following: "Founded upon these principles, the steam-engines which were made by Mr. Watt and his associates and pupils before 1830, produced a horse-power with less than two pounds of coal an hour. These engines are known as the Cornish pumping-engines; and, if you will look into the history of these machines, you will find them reported as doing more than a 'hundred millions of duty,' which is a technical phrase, intended to express the fact that a hundred million pounds of water were lifted a foot high for a hundredweight of coal consumed. Turning that into horse-power, it means about two pounds of coal an hour a horse-power. This result was produced by cutting off steam in the cylinders at one-sixth or one-eighth of the stroke, and allowing it to expand six or eight times. The engines of that day, of course, were very imperfectly constructed, and great losses occurred from leaking pistons and from defective boilers; but, notwithstanding that loss, the result was equal to two pounds of coal an hour a horse-power."

In a note on the subject, reference is made to the authorities showing the "duty" of Cornish engines before 1830 to be more than a "hundred millions," or, what is the same thing, a horse-power with less than two pounds of coal an hour. Perhaps the contrast between the engines did not attract much attention, because the Cornish engine's economy was always stated in terms of weight lifted, whereas economy in other engines was stated in terms of coal an hour a horse-power.

¹ Abstract of a lecture delivered by Edward N. Dickerson, LL.D., before the Electric Club of New York, Jan. 17, 1889.

The lecturer, on this subject, makes this statement: "When steamships came to be built in England in 1840, and afterwards, notwithstanding the fact that high expansion with great economy was in constant operation on James Watt's Cornish engines and on Wolff's compound engines, no attempt was made to work the marine engines under high expansion; and as a consequence all the earlier steamships, for more than thirty years, were running at a cost of at least four pounds of coal an hour a horse-power; while, at the same time, compound engines had been well known for a generation, and were in actual use, making a horse-power for about two pounds of coal an hour. The Cunard Company, however, were making money in their business; and they considered that a sufficient answer to any suggestion that their fuel account was enormously expensive."

It is certainly a very remarkable fact that for a generation steamship-owners did not use high expansion on their ship-engines, when it had been in use on shore for thirty years, both in single and in compound engines.

The fact, perhaps, is not generally known, as stated by the lecturer, that "in 1825 several steamboats on the North River worked by double expansion engines, were built by Mr. Allaire, in this city, — the 'Henry Eckford' for one; and the 'Sun,' which made the trip to Albany in about twelve hours, for another. At that time the subject was not well enough understood, and economy in fuel was not considered of so much consequence as the first cost of construction, and these engines were not largely reproduced. One of these double expansion engines made in England was brought to this country in 1830, and for many years was used in the oil-factory of Judd's Sons, giving very economical results. When they needed more power, a half-stroke cut-off engine was made for that factory and added to the other, but its results were vastly inferior to that of the compound engine."

The explanation is probably the true one, that the greater original cost of compound engines was of more consequence in those days than subsequent economy; and so the compound engines were neglected and lost sight of, till attention was again called to them by Mr. Jameson in 1860, when it was necessary to save a steamship company on the Pacific Ocean from ruin, because of the high cost of fuel there; and he adopted the very obvious remedy of reducing coal-consumption one-half by the use of the old compound engines, which had been disregarded for years.

One very interesting fact brought prominently forward is thus stated: "The astonishing fact exists to-day, that, on an average, every steamboat running on the waters of New York is wasting certainly not less than fifteen per cent of all the fuel consumed, by leaking through the valves; and almost any one of them will run at the rate of four or five miles an hour without ever opening the steam-valves at all, and simply by the leakage through those valves; and yet that leakage is only the difference between what leaks in through the steam-valves and what leaks out through the exhaust-valves. Some of these steamboat-engines are so constructed that the engineer can 'unhook' the steam-valves without unhooking the exhaust-valves; so that, as the engine moves, the exhaust-valves are working, and the steam-valves are shut. That is particularly true of some of the steamboat-engines on the New Haven line; and when the pilot rings the slow-bell, as he frequently must do in going through the crowded thoroughfares, the engineer simply unhooks the steam-valves and lets them drop shut, and the steamboat moves on at a fair rate of speed from the leakage alone; whereas, if those steam-valves were tight, the engine would be stopped in half a revolution. This tremendous loss is not appreciated, because it is a case of internal hemorrhage, and no visible sign appears. The steam leaks into the condenser, and is pumped overboard with the condensing water; but, as far as I have observed, it has not raised the temperature of Long Island Sound at all, and therefore has not produced any effect on climate; and there is no advantage gained by that tremendous expenditure. The remedy, of course, is very simple, and that is to go back to James Watt, which would mean at least fifteen per cent of saving in the coal-bins."

A note very fully explains how this loss occurs, and why it escapes observation. All the earlier steamboats used the single puppet-valves of James Watt, which are necessarily perfectly tight

when once ground into their seats; and, as they are forced into their seats by the pressure of steam, it is impossible for them to leak. But, being heavy to lift by hand, some one invented the double-balanced valve, in which the steam is pressing upward and trying to open the lower of two valves, while it is pressing downward on the upper one; so that there is no trouble in opening them by hand. Of course, such an arrangement must leak; and, when steam once begins to leak, it cuts its way through the crack, and very soon has an open passage.

It has not, however, been supposed that the leak was so enormous as stated; but the lecturer appeals to what he says are facts within his knowledge, and which are easily verified any day. If it is true that steamboat-engines will run the boat without opening the steam-valves, as he says, and that it is done as a practice on some East River steamers when the engine is required to go slow, it is certainly most astonishing that owners should permit such a state of things to continue for a day. As the lecturer says, it is a case of internal hemorrhage, where the patient may bleed to death without knowing the cause.

The lecture contains two cuts, exhibiting the single puppet-valve of Watt, and the double or balanced American valve, as below.

It is very apparent from the sketch that the double valve must be leaky. The pressure upwards on the lower valve

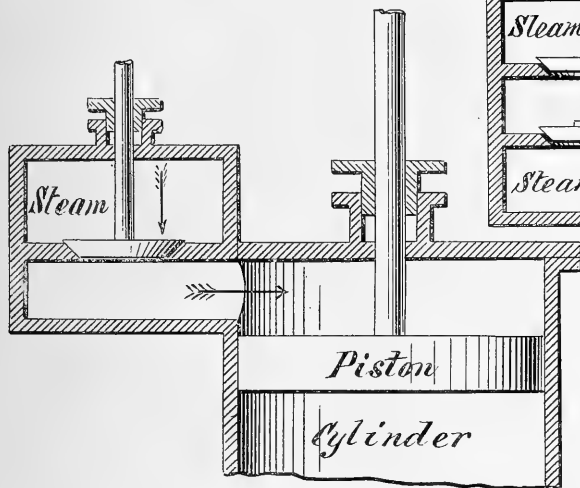

JAMES WATT'S SINGLE PUPPET-VALVE.

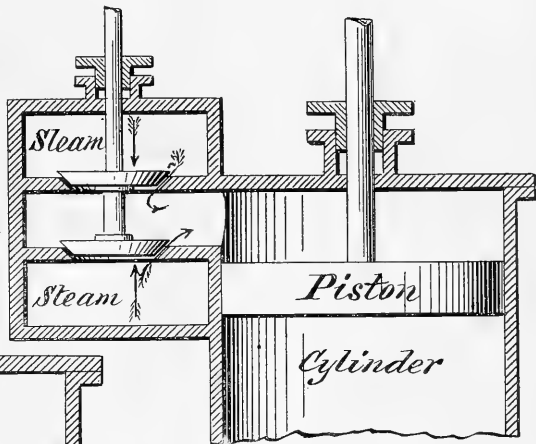

AMERICAN BALANCED PUPPET-VALVE, WHICH MUST LEAK 15 PER CENT OF STEAM USED BY ENGINE.

balances the pressure downward on the upper one, and of course the valve opens easily; but unless the upper and lower valves, which are rigidly separated by a column, can be fitted at exactly the same distance apart that the seats are, of course they must leak, since no pressure can take effect on either to force it into its seat. If they could be so perfectly constructed as to be steam-tight when cold, the moment they are heated by steam, the expansion of the column must differ from that of the enclosing chest, and at once a leak begins; and when it does begin, it soon cuts away the metal.

The lecturer takes up the present theory that great losses are incurred in working steam expansively, according to the laws of Watt, by what is called "cylinder condensation," which is said to destroy as much as one-quarter of the steam introduced into the cylinder, and to that extent neutralizing the theoretical gain by expansion. This hypothesis was put forward by the engineers of the navy in 1860, as the true explanation of a very common fact, that a steam-engine does not give out power in proportion to the expansion used. This explanation was supported by an experiment tried by the United States on an engine on Lake Erie, to which the lecturer refers as follows:—

"In the history of the development of the steam-engine, one cu-

rious phenomenon deserves to be mentioned, and that is the attack upon James Watt and his laws of steam by the Government of the United States during the Rebellion, when vast sums of money were expended in building steam-engines. At that time the Government officially pronounced its judgment of condemnation upon the laws of Watt, and published that judgment in a book, which was distributed to the engine-builders and engineers of the country as the authoritative decision by the United States. This absurd conclusion was reached in consequence of some experiments ignorantly tried by some Government engineers, on a leaky engine on Lake Erie, which, as the report showed, was using more than twice the fuel to the horse-power that James Watt's engines were using. What was proved by the experiment was, that such a machine as that was not a good one to make forty-seven horse-power by expansion; but it was assumed that it proved there was no use in expansion. I quote from that book the following:—

"The results obtained from this engine (that is, the Lake Erie engine) are rigorously applicable to all others in which saturated

steam is employed in a cylinder not jacketed, and, show conclusively the utter futility of attempting to realize an economical gain in fuel, under such conditions, by expanding the steam beyond the very moderate limit of one and a half times; and that, if the expansion be carried to three times, a positive loss is incurred; also that if measure of expansion, as high as those due to cutting off the steam at $\frac{1}{4}$ or $\frac{1}{8}$ of the stroke of the piston, are employed, the economy is considerably less than with steam used absolutely without expansion."

"Upon that principle, the whole steam navy of the United States that was built during the war was constructed. This was a tremendous blow to progress, from which we have not yet entirely recovered; and but for the fact that the engineers of Europe have since built their magnificent steamers, and carried expansion to a high degree, we should have been building a navy to this day in accordance with this ignorance. But James Watt, for a dead man, made a magnificent fight in defence of his principles; and the money and resources of the United States have utterly failed to defeat him."

In an elaborate note, an explanation is made of the way in which this remarkable conclusion was reached, supported by the tabulated report on which it was supposed to rest. As the table shows, the "Michigan's" engine was run at various rates of expansion, beginning at nearly full stroke, and running down to a cut-off at one-eleventh of the stroke, — the pressure of the steam being kept constant, and the revolutions of the engine kept the same, by taking off resistance, — so that at full stroke the engine developed 280

net horse-power, and at one-eleventh of the stroke only 47 horse-power, and in that proportion. Each experiment lasted seventy-two hours. The water was carefully measured as it was taken into the boiler; and the steam which resulted from that water was estimated from the indicator diagrams as it went into the condenser. The result of these trials is thus stated in a note, quoting the figures from the report:—

"In round numbers twelve hundred pounds of water an hour disappeared from the engine, whether the steam followed the piston full stroke, or was cut off at one-eleventh of the stroke; and, of course, the expansion rate had nothing to do with its loss. Indeed, at the high expansion there appeared less loss of water than at lower rates. The fact, of course, was that the double-balanced puppet-valves of that engine leaked about the same amount of steam into the condenser an hour when the engine was running, and it made no particular difference whether the cut-off was long or short.

"If the estimated water in steam, as shown by the indicator, could have been ascertained as accurately as the water pumped in was, it would have appeared that at the high rates a still smaller loss occurred than the tables show, as compared with full stroke; because, after the cut-off valve shuts, the steam-pressure falls off in the cylinder, and less steam ought to leak into the condenser than if the boiler-pressure were kept up in the cylinder during its entire stroke; but these indicator measurements cannot be exactly accurate. They, however, established the fact that in this case high expansion destroyed less steam than full stroke, and so completely demolished the theory which the experiment was tried to establish. That, however, did not prevent the forcing of balances, and other similar manipulation of the honest figures, in order to prove the hypothesis under which the experiment was tried; and the result was announced that the Lake Erie experiment had proved what it was intended to prove, and the official United States Government report was issued to the world, announcing the new discovery.

"If book-keeping could have beaten James Watt, he and his laws would have perished from the earth; but, as it was, they were only driven for a season out of the American Navy."

It is not important for science to know whether the conclusion drawn from the facts was fraudulent, as the lecturer asserts, or simply a stupid blunder. The fact is, that an almost constant quantity of steam disappeared from the engine in an hour, under all circumstances, and of course its loss had nothing to do with expansion. The quantity—twelve hundred pounds an hour—was a very large percentage of 47 horse-power, and a small percentage of 280 horse-power; and this fact was put forward as proving that expansion destroyed a much larger amount of steam used than full stroke did, whereas in fact a trifle less steam was destroyed when high expansion was used than at any other time.

The explanation, open to any one's verification by the tables themselves, disposes of this extraordinary trial, and destroys the theory based upon it. It is great service to truth to make this exposure.

The lecture ends with this expression of opinion:—

"It is my opinion, that, with our present knowledge of machinery, a steam-engine can be built to day that will produce a horse-power with three-quarters of a pound of coal an hour, if of sufficient size to reduce the percentages of loss by radiation, friction, and leakage, to a minimum. Under those circumstances, your fuel expense would be less than one-third of what it now is."

It would seem that there should be some means of bringing this to a test. No one claims at present less than a pound and a half an hour in the most elaborate and extensive steamers; and, if this opinion is correct, half the coal now used, or a power double that now got from the same fuel in the most perfect machine, would be the result of such an engine.

In a review we cannot go over the whole ground on which the lecturer places the case; but to those specially interested in the subject there is matter enough for very serious consideration, and we commend the paper to their notice.

SETH K. WARREN of Geneva Lake, Wis., publishes a little volume devoted to the "Evolution Theory of the Origin of Worlds."

IMPROVED GASLIGHT.

NOTWITHSTANDING the rapid development of the electric-light industry, gas still remains the most widely used and convenient illuminant; and any means of improving the quality or decreasing the cost of gaslight is of interest to the public. One improvement in both these features, now attracting much attention, is known as the "albo-carbon light."

In this light the ordinary illuminating-gas is passed through a simple apparatus, in which it is enriched by taking up a hydrocarbon vaporized by a current of heated gas. It is claimed by the company who have introduced it to the public that one thousand feet of common coal-gas, after being passed through their appliance, will give fully as much illumination as three thousand feet where ordinary burners are used; in other words, the cost of illumination is reduced to at least one-half, while the light is far more satisfactory. The apparatus can be attached to any ordinary gas-pipe or gas-fixture in a few minutes, and no change in the meter or

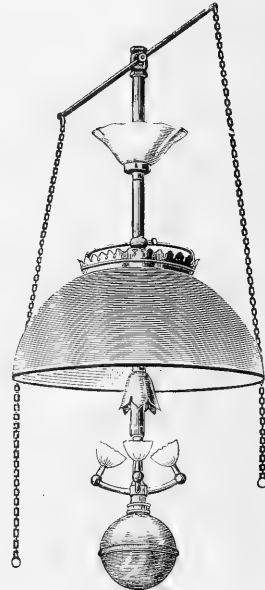

THE ALBO-CARBON GAS-FIXTURE.

gas service is required. The carburetting vessel is detachable, and may be readily removed from the fixture for refilling with "carbon." This operation is quickly performed, and the whole appliance is so simple that it requires practically no attention. There is no complicated mechanism, and consequently nothing to get out of order.

The adaptability of this light for illuminating purposes under all circumstances is proved by the fact that it is now in use in many of the largest business-houses in this city and Brooklyn. Professor Stevens of Girard College, Philadelphia, says of it, "I have tested the albo-carbon light. . . . The burner consumed 2 cubic feet of gas per hour. One foot of common gas per hour equalled 2.5 candles, while one foot of the gas when carbonized equalled 8.125 candles. Regarding candle-power, the carbonized gas is equal to 3.25 times the common gas. Comparing the common gas with the standard 5-foot Argand burner, 5 feet per hour with the Argand burner equalled 17.20 candles; 5 feet of carbonized gas equalled 40.625 candles, which is 2.36 times the candle-power of the standard Argand. . . . The perfectly steady, soft light furnished by the albo-carbon burner adapts the light admirably for reading, for manufacturing establishments especially, and for general household uses."

The tests referred to above refer only to single lights: when the

alco-carbon light is burned in clusters of burners, a much more striking effect, with a far higher result in lighting-power, is produced. An eight-light cluster tested on London 16-candle gas gave 8.84 candles per cubic foot, while with the larger clusters the increase in candle-power is still greater. This light may be seen in use every evening at 728 Broadway, this city, the office of the Alco-Carbon Light Company.

THE NEW WESTON VOLTMETER.

It is a law of human progress, nowhere better exemplified than in the industrial and mechanic arts, that all systematic and permanent advance depends upon our ability to determine quantitatively, in terms of some standard, the value of the various factors involved in any given operation or transformation. An idea of the crudeness of men's notions of measurement in former times as compared with the present, may be gained from the names of units or stand-

ard the elimination of guesswork and the substitution of knowledge. Engines, dynamos, batteries, electric motors and lamps, are sold with a guaranteed efficiency and life, subject, however, to definite conditions as to use. It is generally because of the absence of definite knowledge as to when the imposed conditions are actually observed, that losses so frequently exceed profits. When measurements of the value of electrical appliances are actually made, the results are often discredited because of doubt as to the accuracy of the instruments used, and probably the general indifference to accurate work manifested by many electricians may be justly ascribed to the absence of reliable measuring instruments.

Most of the commercial electrical measuring instruments in use in this country to-day are of foreign manufacture. They may be briefly described as either of the permanent or electro magnet type. The former are in general disfavor, and unjustly so, because their defects are not inherent in the types, but are, rather, the natural result of poor design and construction. Those who have had much



FIG. 1.

ards which have been handed down to us. Thus three barley-corns made one inch, the foot was the length of the king's pedal extremity, the hand is a measure still in use in estimating the height of horses, etc. Compare such notions with the accuracy required in modern machine-shop practice. It is, in fact, only when the value of work already done becomes known, that one is prepared to make further progress, as every step in advance demands increased refinement in the means and methods of measurement. As an instance in point, witness the mutual development of the steam-engine and the steam-engine indicator. Just as the indicator has advanced to a state of perfection such that its records are universally relied upon to detect faults in present apparatus, and intelligently outline the direction of improvement, so has there been a gradual advance in the construction of commercial electrical measuring instruments, serving a similar purpose, and tending to effect a similar result, in electrical engineering.

While it is true that thousands of engines are never indicated, and thousands of electrical appliances are never carefully tested, it is equally true, as a consequence, that useful energy is wasted, property destroyed, and money lost.

In electrical as well as in mechanical engineering, success neces-

sary experience with these instruments, of which the Deprez and Ayrton & Perry are examples, will recognize the fact that while these instruments are new, they are subject to rapid and serious changes in their constant. The rate of change, however, diminishes with age and use, up to a certain period, when they assume a condition of stability, and are thenceforth, in so far as the controlling force is concerned, reasonably reliable. Uncertainty as to when this condition of stability is attained necessitates frequent calibration, and is thus a serious obstacle to accurate work. A second defect is the heating error introduced when the instruments were kept in circuit even for the short time necessary to make readings.

Instruments of the electro-magnet type are, on the other hand, more generally in demand, because of the prevalent idea that they are not subject to errors arising from a variable controlling force. Errors, however, fully as serious as have been ascribed to permanent magnets, are not only common, but seemingly inherent, in this type, because of the magnetic persistency of the softest iron, even when subdivided. This error is most noticeable when readings are made with a rising, succeeded by a falling current, and often amounts to as much as twenty-five or thirty per cent. The best forms of this type of instrument are, perhaps, the ingenious

spring voltmeters and ammeters of Ayrton & Perry. These are, however, subject to serious heating and frictional errors.

Thus far we have mentioned only the most glaring defects common to commercial instruments. Another and almost universal defect is due to inaccuracies in the reading-scale. A great advance was certainly made when direct-reading instruments were substituted for those requiring a multiplying constant. It is a notable fact, however, that most of the direct-reading instruments, judged by the uniformity of their scale-divisions, follow the proportional law. This is extremely doubtful, however, and calibration generally reveals the fact that seldom are there more than two or three of the scale-marks correct. Printed or engraved scales may justly excite suspicion as to their accuracy.

The advent of an improved type of commercial electrical measuring instruments for direct-current circuits, in which the sources of error enumerated above are practically eliminated, and which are equally well adapted for both laboratory standards and commercial service, is justly to be regarded as an important step in the develop-

nary use, is now generally acknowledged. In these instruments special care has been taken not only in the selection of steel and its proper magnetization and artificial aging, but the magnetic resistance of the acting field has been reduced to its lowest practical limit by the insertion of a central core of soft iron within the movable coil. This core is supported upon the magnet frame by a strap of diamagnetic material. The form of the pole-pieces is such that the deflecting coil constantly moves in a uniform field, and hence the deflections practically follow the proportional law; and a direct-reading scale, of nearly equal subdivisions, is obtained. The movable coil is wound upon a light frame of copper, which serves the double purpose of a support, and also, since it moves in an intense field of force, as a damper, thus making the instrument exceedingly dead-beat.

All of the more important parts of the instrument are made to gauge, and the bearings of the deflecting coil are jewelled. Interchangeability of parts, and the elimination of friction, are thus obtained. A difference of potential of about one and one-quarter

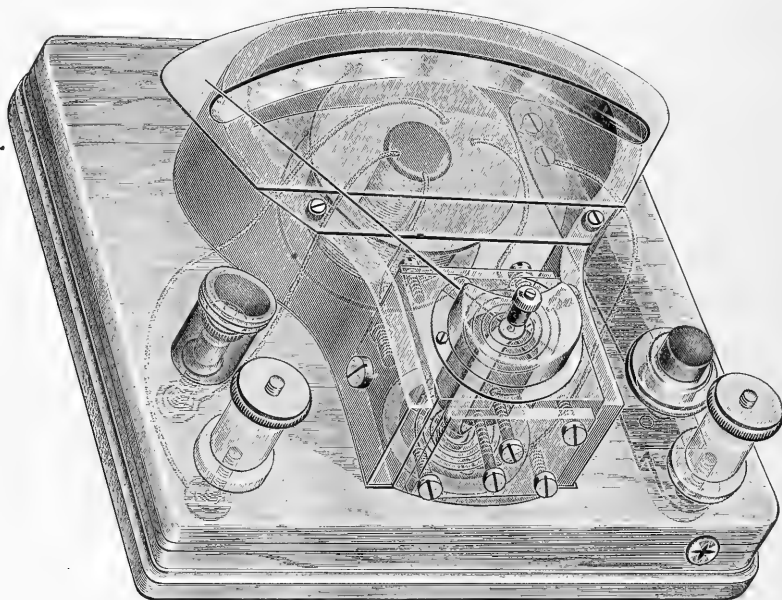

FIG. 2.

ment of electrical engineering. The Weston Electrical Instrument Company of Newark, N.J., have recently placed upon the market a new form of commercial voltmeters and ammeters, designed by Edward Weston, the well-known electrician. The especial aim in designing these instruments has been not only to entirely eliminate such variable factors as have been enumerated above, but to add to the instrument certain valuable features mentioned below. To this end, the electrical, magnetic, and mechanical features have been so worked out as to insure permanence and reliability, coupled with simplicity, extreme accuracy, a wide range of scale-reading, and portability. The accompanying engravings (Figs. 1, 2, and 3) give general and detailed views of the voltmeter. It will be seen that the field of force is produced by a permanent magnet of peculiar form, while the deflecting body, carrying the index, is a light coil of insulated wire, whose motion, resulting from the dual fields established by the magnet and current circulating in the coil, is restrained by two coiled springs. The springs serve also to convey the current into and out of the moving coil.

That permanent magnets can be, and in fact are, daily made, which, after undergoing a process of artificial aging, remain thenceforth practically constant in strength when subject to ordi-

navolts, at the terminals of the movable coil, serves to deflect the index over the entire scale, the length of the scale being about six inches. This degree of sensitiveness permits, therefore, the construction of instruments having a wide range of maximum scale-reading by the simple insertion of differentially wound resistance-coils, in series with the movable coil.

Figs. 1 and 2 exhibit the external and internal parts respectively of the new voltmeter, having a scale of double values, with a ratio of 20. The scale divisions for the upper values (Fig. 1) are single volts, while for the lower values they read one-twentieth of a volt. The single divisions are of such a size that one can easily read to one-tenth of a division; namely, to one-tenth of a volt on the upper values, and one two-hundredth of a volt on the lower. This form and ratio of scale values is useful for battery-work, and especially for storage-batteries. The lower scale values are used when examining single cells, or sets of two; and the upper scale values, when measuring the aggregate potential difference of a series of cells. In the former case, connection is made with the small binding-post (under the rubber cap) on the left, and with the larger binding-post on the right. In the latter case, connection is made with the two large binding-posts.

Another very important feature is the means afforded those not in possession of laboratory appliances of verifying the scale value by applying a single cell of some constant form, such as is to be found in any telegraph-office, to the terminals of the coil giving the lower scale-reading. The deflection noted serves as a standard for future comparison with the same or a similar cell, should doubt arise as to the effect of accidental rough usage.

All scale-readings begin at zero, and extend by practically uniform increments to the maximum reading. The range of scale-readings for instruments of a given maximum scale is thus greater than is common; and, as the divisions of each scale are the result of individual calibration and checking, the scale-readings are uniformly accurate. The temperature correction is negligible, and the instruments can be kept constantly in circuit, as their resistance is so high (averaging twenty thousand ohms) as to prevent any appreciable heating error. The ammeters have the same general appearance as the voltmeters, and possess the same merits of permanency and reliability.

In the hands of electricians and electrical engineers, these instruments are claimed to afford the means of obtaining measurements

We may fairly conclude, then, from all of these experiments, that the effects observed in the micrometer circuit were produced by oscillations in the discharge circuit of a period approximately equal to that calculated from the dimensions of the apparatus, in the neighborhood of a hundred-millionth of a second.

Hertz concluded, that, if vibrations were caused in the micrometer wire, there must be nodes (points of zero disturbance) somewhere

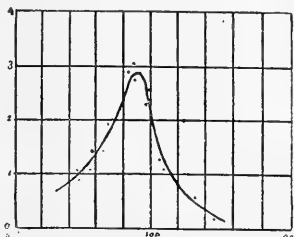

FIG. 5.

Curve showing relation between length of side of rectangle (taken as abscissa) and maximum sparking distance (taken as ordinate), the sides consisting of straight wires of varying lengths.

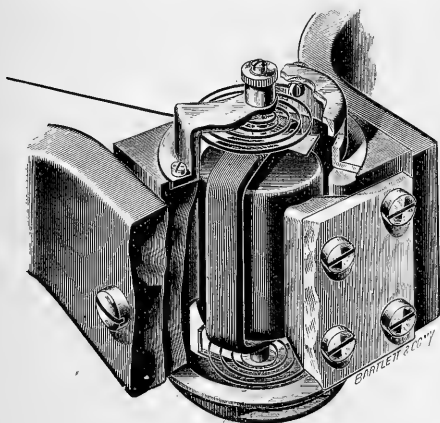

FIG. 3.

along its length. To prove this, he adjusted his micrometer circuit to resonance with the discharge circuit, making the gap in the former so wide that sparks were just able to pass. Then a sphere was made to touch different points along the wire, the result being a cessation of the sparks except when the point of contact was at the middle, showing that there was a node at that point. Again, by using a second micrometer circuit similar to the first, as in Fig. 5 (Fig. 7 in the paper), nodes were found to occur on *cd* and *gh*. When the wire connecting 2 and 4 was removed, the vibrations were not disturbed; but when the knobs at these points were brought close together, a slight spark was observed between them, the spark corresponding to a vibration with a single node at *ae*. We can, then, in the same conductor have vibrations with one or two nodes, according as we wish; that is, we can excite in it its fundamental

correct to within one-fifth of one per cent, and special instruments are made correct to within one-tenth of one per cent. If the limits of error were even ten times as great as claimed, these instruments would, it is said, possess greater accuracy than has been heretofore attainable in commercial voltmeters and ammeters. It is most certainly to be hoped that actual practice will substantiate the accuracy of these claims.

ELECTRICAL NEWS.

Hertz's Researches on Electric Oscillations.¹

IN order to get resonance phenomena between two circuits, Hertz used an arrangement consisting of a straight copper wire divided into two parts by a discharger, the two halves being connected with the secondary of an induction-coil, while two hollow zinc spheres were arranged to slide on the halves. The micrometer circuit was made of such dimensions as to have a slightly shorter period than that of the discharge circuit, supposing the oscillations were really as rapid as was calculated. The experiments were made in two ways. First, the period of the micrometer circuit was increased: the result was an increase in the length of the spark that could be obtained in it, followed by a decrease, as the capacity, and therefore the period, became too great. Afterwards, the micrometer circuit remaining constant, the period of the discharge circuit was decreased, the result being, as before, an increase in spark-length in the micrometer circuit, followed by a decrease.

¹ Continued from No. 313.

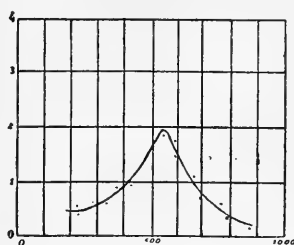

FIG. 6.

Curve showing relation between length of side of rectangle (taken as abscissa) and maximum sparking distance (taken as ordinate), the sides consisting of spirals gradually drawn out.

note or its first overtone. As to the higher overtones, Hertz considers it doubtful whether it is possible to produce them, for the results show that the damping effects must be considerable; and there are many secondary phenomena which show that irregular vibrations are superposed on the regular ones. To obtain the best results, Hertz observes that there is a longer spark in the secondary when it is exposed to the light of the discharge circuit.

Let us now call the discharge circuit the primary, and the micrometer circuit the secondary. The next experiment Hertz tried was with a primary circuit of straight copper wire, carrying at its ends zinc

spheres, and having a break in the middle for the discharge spark; the secondary being a circle of copper wire, broken by an air-space which was capable of adjustment by means of a micrometer screw. The two were adjusted until they were in unison, and the effect of the primary on the secondary was observed for different positions of the latter. There are in reality two electro-motive forces acting upon the secondary, — one an electro-static force, due to the rapid variation of the distribution of charge on the primary; the other an electro-magnetic effect, due to the current oscillating back and forth on the primary wire. Now, it is a matter of very great im-

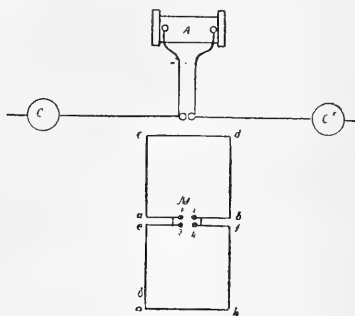

FIG. 7.

portance to find the effects of these two. In the lower part of Fig. 6 (Fig. 8 in the paper) the lines *mm* represent different positions of the secondary, which was vertical. The sparks in the secondary disappeared when the air-space was in the horizontal plane passing through the primary, and were a maximum for points at right angles to these. The arrows give the resultant force, which does not differ greatly from the electro-static distribution due to charges on *A* and *A'*.

When the secondary was horizontal, as in the upper part of Fig. 6, in position *I* there were two maxima of spark distance, when the air-space was at a_1 and a'_1 ; in position *II* the maxima were at a_2 and a'_2 , the distance at a_2 being the greater; in position *III* there was but one maximum, at a_3 , with a point of disappearance at a_3 ; at *IV* there was a maximum at a_4 , a minimum at a'_4 ; at *V* there was a maximum at a_5 , a minimum at a'_5 . From the position *III*

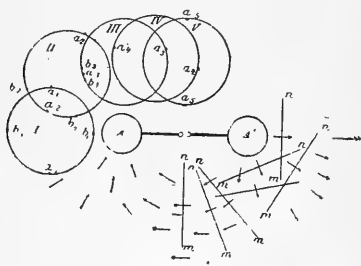

FIG. 8.

to the position *V* the line *aa'* swung rapidly from a direction parallel to *AA'* to one perpendicular to it.

Now, what all these experiments mean is this: the electro-static force is more important than the electro-magnetic within the distances at which observations were made, excepting in the last cases, *IV* and *V*, where the electro-magnetic force comes in. But, as it is of the greatest importance to find out what takes place at a distance from the primary, Hertz extended his observations until the secondary was as much as 14 metres from the primary. At a distance of about 1.5 metres the maxima and minima became indistinct, but beyond this they were clearly defined again. From his observations, Hertz plotted out the distribution of force in the

room, the result being like Fig. 7 (Fig. 9 in the paper), where the lines indicate the direction of the force, the stars representing the points where the direction is indeterminate. We see that at distances beyond three metres the electro-motive force is everywhere parallel to the primary, — that is, the electro-static effect is negligible, — and we find that the effect diminishes very much more rapidly in the direction of the vibration than at right angles to it. For less distances than one metre, the distribution of electro-motive force is practically that of the electro-static force.

There are two lines at all points of which the direction of the electro-motive force is determinate, — the line in which the primary oscillation takes place, and a line at right angles to it. But there are regions in which the electro-motive force becomes indeterminate: these form two rings around the primary, the projections being the stars in the figure. Since the electro-motive force within them acts very nearly equally in every direction, it must assume different directions in succession, for of course it cannot act in different directions simultaneously. The observations, then, lead to the conclusion that within these regions the magnitude of the electro-motive force remains nearly constant, while its direction varies through all the points of the compass during each oscillation. Dr. Hertz thinks the results very difficult of explanation, unless we suppose the electro-static and electro-magnetic electro-motive forces are propagated with unequal velocities, in which case we have within the annular regions two electro-motive forces at right angles, and differing in phase; and as a consequence the resultant will turn through all the points of the compass at each oscillation.

One great value of the above series of experiments lies in the fact that they enable us to put aside such theories as do not agree with the observed results; and, as there are a considerable number of theories, we are thus saved much confusion.

The next subject which Hertz took up was the idea of displacement currents in a dielectric, — an idea which underlies so much of Maxwell's work. Briefly, the assumption made by Maxwell is, that, if two conductors are charged positively and negatively respectively, then in the dielectric between them there is a corresponding displacement of electricity across any surface surrounding either. The displacement current lasts as long as the conductors are being charged, and has magnetic effects, just as a current in a conductor has. To show the existence of these displacement currents, Hertz arranged the experiment shown in Fig. 8 (Fig. 10 in the paper). Here the primary circuit consisted of the two conductors *A A'*, joined by a wire with the air-space for the discharge in the middle. The secondary circuit was adjusted in unison with the primary, and was placed in such a position that there was no sparking. If, now, a conductor *C* be held near *AA'*, equilibrium was disturbed, and sparks passed at *f*. On removing *C*, and approaching a dielectric, if no effect was observed, then the dielectric would be shown to have no magnetic action, and Maxwell's theory would fall to the ground. But on trying the experiment, a decided effect was produced, thus proving that the dielectric exerted magnetic actions, and that Maxwell's notion of displacement currents is in all probability correct.

ELECTRIC PLANTS IN THE NAVY. — The report of the naval inspector of electric lighting, Lieut. R. B. Bradford, contains a summary of the work performed under the supervision of this office. After describing the installations on the "Trenton," the "Omaha," the "New Hampshire," the "Atlanta," the "Boston," the "Chicago," the "Yorktown," the "Baltimore," the "Charleston," and the "Pensacola," the report goes on to say that search-lights are at times very useful, but discretion must be exercised as to when and how to use them. During the recent English evolutionary squadron exercises, the search-lights of the blockading squadron failed to detect the escaping ships of the enemy, which had, of course, all lights out and every thing visible carefully colored a dead black. On the other hand, the enemy's ships which were not trying to escape used their search-lights to blind the eyes of the blockaders and interfere with the rays of their searchers. Recent experiments in Russia indicate that it is not an easy matter to disable a search-light with machine-guns and shoulder-rifles, on account of the light blinding the eyes and interfering with the aim. It is found in Germany, however, that if search-lights are placed

behind men with the beam of light on a target, very good practice can be made, so long as the men are in the beam, the sights of the guns then being illuminated; if, however, the men are out of the beam, and consequently invisible, the accuracy of the practice is much reduced.

THE AXO BATTERY.—The most widely used galvanic cell for "open-circuit" work—that is, for bells, burglar-alarms, telephones, etc., where the current is only taken out for short times—is the Leclanché, or some of its modifications. The cell has many advantages: it needs very little attention, its electro-motive force is comparatively high, there is no eating-away of the zinc when the cell is not working. The only troubles have been in the evaporation of the liquid, the creeping of the solution over the edges of the jar, and the corrosion of the



binding-post contact at the carbon pole. These defects are remedied in the new Axo type of Leclanché cell shown by the illustrations. Here the porous cup forms of itself the cover of the cell, which is hermetically sealed by pouring wax or paraffine in the space between the top of the cup and the edge of the jar. As the depolarization of the battery requires that there be a certain amount of ventilation, this is secured by deep grooves in the sides of the carbon, coming above the cover of the jar. It will be seen that the zinc passes through a separate hole in the side of the jar, which is closed by a rubber stopper. The connection with the carbon is made by a patented metallic clamp and thumb-screw, shown in the figure. Taken altogether, the Axo is an advance in galvanic cells. It can be sealed and left to itself, until, as must finally happen in every battery, the zinc and solution have to be replaced, when with very little trouble it can be practically renewed. For ordinary bell-work it would probably last a year or more without attention.

NOTES AND NEWS.

PROFESSOR SHALER of Harvard has returned from his tour of geological exploration through the Dismal Swamp.

—The Rev. Dr. George E. Reed, pastor of the Trinity Methodist Church of New Haven, is now at work upon his letter of acceptance as president of Dickinson College of Carlisle, Penn.

—Mr. F. Küstner has made a very interesting series of observations on the aberration of fixed stars, and, from certain discrepancies between early observations made by Struve and recent ones made by himself, arrives at the conclusion that the altitude of the pole, which is assumed to be a constant in the formula applied, is in fact variable. He found that in the fall of 1884, at Berlin, the polar altitude must have been 0.2" greater than before and after that season. As this result appeared somewhat startling, he subjected other observations made at Pulkowa and Gotha to a thorough investigation, which proved the correctness of his view. Mr. Küstner

attributes these variations to meteorological and hydrological phenomena which are caused by the action of the sun. Helmer's investigations tended to show that these irregular movements of matter might result in changes of latitude not exceeding a few hundredths of a second, while William Thomson concluded that these changes might be as great as half a second. From Küstner's observations, it appears that the real changes are intermediate between these two values.

—Professor Hill of the School of Geology of the University of Texas plans the establishment at the university of an educational museum which will represent in the broadest sense the geologic conditions—structural, economic, organic, and general—of the earth, and to illustrate these features as far as possible by Texas material accompanied by maps, models, and labels. This museum will exhibit not merely the extraordinary, but also the far more important and too little valued ordinary features of that State; so that any person, citizen or stranger, will find compactly arranged in the halls of the university a complete and instructive synoptical exhibit of all the diverse natural features of Texas. The museum will also be a medium of exchange with similar institutions outside the State. The attention which will be attracted abroad by properly prepared and representative specimens from Texas, conveying clear and accurate scientific information that can be disseminated in no other manner, will attract the earnest interest of a class of intelligent people who cannot be otherwise reached. The functions of the museum will also be distributive as well as collective, and its utility not confined to the university building, but disseminated throughout the State, it being the intention to select from its duplicates typical educational series for distribution to high schools connected with the university wherein the natural sciences are taught.

—A movement has been started in Norway, says *Nature*, for the despatch in the summer of 1890 of an expedition which will try to reach the north pole, and it is proposed that the leadership shall be offered to Dr. Nansen. Those who are arranging the plans maintain that no other country could furnish such a crew of experienced and hardy ice-men and arctic travellers as Norway, and that a winter or two in the arctic regions would affect these men very little. The intention is that an attempt shall be made to reach the pole by way of Franz Josef's Land, a route advocated by the most experienced Norwegian arctic travellers as well as by several well-known men of science who have studied the problem. *Szö*, which have played such a prominent part in the Norden-skiöld and Nansen Greenland expeditions, would no doubt again be of great service.

—The board of overseers of Harvard College, at a meeting held Jan 30, adopted, after prolonged discussion, the following vote: "Voted, that, in the opinion of this board, it is expedient that every undergraduate be requested to report in person early every morning, with a moderate and fixed allowance for occasional absences; that attendance at the exercises of each course be more rigidly enforced; that the system of advisers, somewhat as applied to special students, be extended to the freshman class; that the reports of the presence and absence of students be collected daily by monitors, and daily entered on the books; that no choice of studies made by a student be valid if it calls for more than three lectures or recitations on any day of the week, unless the choice has been specially allowed by the dean; that, in order to make it more difficult for students to prepare by a brief period of cramming to meet the tests applied, the faculty require all the instructors to provide tests of the progress of their students with sufficient frequency to enable them to enforce effectively Section 7 of the Regulations; that admonition be administered by the dean on his sole authority, and that the powers of that officer be so enlarged, at whatever increased expense it may be necessary to incur, that the records of attendance may always be ready for inspection by the proper officers; that the faculty be asked to prepare and report a series of rules, which, in their judgment, will give practical effect to these recommendations." This was adopted by a vote of 16 yeas to 4 nays, those voting in the negative being President Eliot, Dr. Phillips Brooks, Dr. Walcot, and Charles R. Codman. The carrying-out of these recommendations will depend on the faculty, which, it is understood, are opposed to their spirit.

SCIENCE:

A WEEKLY NEWSPAPER OF ALL THE ARTS AND SCIENCES.

PUBLISHED BY

N. D. C. HODGES,

47 LAFAYETTE PLACE, NEW YORK.

[Entered at New York Post-Office as second-class mail-matter.]

Subscriptions.—United States and Canada.....	\$3.50 a year.
Great Britain and Europe.....	4.50 a year.
Science Club—rates for the United States and Canada (in one remittance):	
1 subscription 1 year.....	\$ 3.50
2 " " 1 year.....	6.00
3 " " 1 year.....	8.00
4 " " 1 year.....	10.00

Communications will be welcomed from any quarter. Rejected manuscripts will be returned to the authors only when the requisite amount of postage accompanies the manuscript. Whatever is intended for insertion must be authenticated by the name and address of the writer; not necessarily for publication, but as a guaranty of good faith. We do not hold ourselves responsible for any view or opinions expressed in the communications of our correspondents.

VOL. XIII. NEW YORK, FEB. 8, 1889. No. 314.

CONTENTS:

THE THORNE TYPE-SETTING MACHINE.....	93	SOMETHING ABOUT TORNADOES <i>J. P. Finley</i> 105
THE STEAM-ENGINE, ITS PRINCIPLES, ETC. <i>E. N. Dickerson</i> 94		A RIVER-PIRATE <i>W. M. D.</i> 108
IMPROVED GASLIGHT.....	95	A POPULAR OBSERVATORY..... 109
THE NEW WESTON VOLTMETER.....	97	SCIENTIFIC NEWS IN WASHINGTON.
ELECTRICAL NEWS.		Irrigation in California..... 110
Hertz's Researches on Electric Oscillations.....	99	The Nucleus of a "Zoo"..... 110
Electric Plants in the Navy.....	100	Mounds of Ohio..... 110
The Axo Battery.....	101	Triple Births in the Human Race..... 110
NOTES AND NEWS.....	101	The Talking-Machine in Use..... 110
EDITORIAL.....	102	Where Will It Go Next?..... 110
The New York Schools again.—International Copyright.—President Eliot's Annual Report.		BOOK-REVIEWS.
SCIENCE AND THE DICTIONARY.....	103	The Teachers' Psychology..... 110
SPEECH AND ALPHABETICS <i>A. Melville Bell</i> 104		AMONG THE PUBLISHERS..... 111
		LETTERS TO THE EDITOR.
		The Baconian Method in Science <i>Logicus</i> 112

THE MANY KIND and appreciative words that our recent editorial comments on school matters have called forth are sufficient proof that we have succeeded in arousing an interest in this most important matter. Our Wednesday of last week the New York City Board of Education discussed the report of the committee on reform, but adjourned without taking any action. As we go to press, the matter is again under discussion. The character of the meeting of last week is now re-assuring. The "wrigsters" in the board received Mr. Webb's opening remarks in sullen silence, and, when finally one commissioner did find his tongue, it was to say that no marking system prevailed in New York city schools! This astounding statement is so transparently false, that we are quite at a loss to know why it was made. We can only interpret it as a sign that the opposition propose to treat the whole matter with an ignorant bravado. This attitude, however, will not be tolerated by the public nor by the independent section of the press. The question must be squarely met, and a vote must be taken. Another commissioner, one who knows nothing whatever about the schools as they now exist, proclaimed that they were perfect, and cited himself, a graduate of them, in evidence. This line of argument

will hardly be accepted as conclusive. The well-known fact is, that abuses of the most outrageous kind exist,—favoritism, political methods, bad teaching, and the rest,—and they are wasting the lives of hundreds of thousands of children. The Board of Education *must* cope with them.

THE AMERICAN [AUTHORS'] COPYRIGHT LEAGUE has issued an appeal, asking the support, by all interested, of the Chace-Breckinridge Copyright Bill, which passed the Senate May 10 by 34 to 10, and is now before the House of Representatives. This is a compromise measure, the outcome of years of labor. Whatever its defects, this bill, the league believes, "will put a stop to the habit of piracy; will free American authors from the competition with stolen goods; will enable American writers to support themselves by their pens; will make American books cheaper by opening to them the broad home market now supplied with inferior foreign work; will give American books a chance to reach the American people, who now read many worthless books by foreign authors, reprinted in rival editions solely because they can be had for nothing; will result in securing to American authors important and growing foreign markets; and will take from our country the stigma of being the only great nation in the world which despoils the foreign author."

In this connection it is interesting to note, that, according to the Washington correspondent of the *New York Evening Post*, "the friends of the Copyright Bill have a plan for bringing up the bill in the House which they hope will be successful. The plan is to have a rule reported that will cover this bill. The great difficulty has been to induce the Republicans to agree not to insist that any such rule shall be amended so as to make it in order to call up pension-bills for passage. The Democratic Representatives are determined to resist any further pension legislation in this Congress. Some of the Republicans think that they have made all the 'record' as to pensions that is necessary, and that it is expedient to pass the Copyright Bill. There was a dinner on Saturday night, Jan. 19, which was attended by Mr. Houghton of Boston, Edward Eggleston, and others interested in the copyright matter, and by some of the leading members of the House, including Messrs. Cannon of Illinois, Long of Massachusetts, Adams of Illinois. Some of the Western members have been influenced by the concentrated attack upon the bill that has been made by the American Press Association, which furnishes the country newspapers with patent insides. The friends of the bill are endeavoring to counteract this influence, and to answer the stereotyped petitions which have been sent to the country newspapers for signature. Dr. Eggleston reports that a large majority of members of Congress, who at the opening of the session found their mails crowded with bogus petitions purporting to come from typographers, have had their eyes opened to the fictitious nature of these petitions by the representatives of the typographical unions who have visited Washington to assure members that the unions are heartily in favor of the bill, and that the opposition is, so far as they can find out, supported and paid for by certain British publishers who are afraid to lose business if the bill becomes a law. The fact that the *Union Printer* of New York, edited by W. M. Rood, and which is the official organ of the typographical unions in that part of the country, is giving hearty support to the bill by editorial articles, and joining hands with the organ of Union No. 2 of Philadelphia, shows the spirit in which the members of the craft are taking hold of the matter."

THE ANNUAL REPORT of the president of Harvard College is always looked for with interest, and for some years past *Science* has made it a custom to call attention to this report as soon as it is issued. The report of 1887-88 is before us; and, while it contains no features of striking interest, yet it chronicles a steady progress

along the line which the authorities of Harvard have marked out for themselves. Appreciative reference is made to the work of Professors Asa Gray and Ernest Young, who died during the year, and also to Robert D. Smith and James Freeman Clarke, whom death removed from the board of overseers. Mr. Eliot notes the fact that in 1888 the examinations for admission to the college were for the first time conducted exclusively on the new plan announced in 1886. It seems that the secondary schools and the private tutors have already responded in considerable measure to the new suggestions and requirements of the faculty. Of the 315 candidates who completed their entrance examination in 1888, 31 presented the history of the United States and of England instead of the history of Greece and Rome; and 93 presented elementary experimental physics, as recommended by the faculty, instead of descriptive physics and astronomy. Both French and German were presented by 110 candidates. The figures prove that the new requirements have already stimulated the teaching of modern languages in secondary schools, and have promoted the introduction of laboratory methods of studying physics and chemistry. It is pointed out that in the progress of converting Harvard College into a university of liberal arts and sciences, about the same gain was made in 1887-88 as in each of the years immediately preceding. "Progress," says President Eliot, "may be made in one or more of four principal directions: (1) in amplitude of instruction; (2) in freedom in choice of studies; (3) in better arrangement and co-ordination of studies within single departments; and (4) in *morale*." The gain in the volume of instruction during the year 1887-88 was about five per cent; that is, from 485 hours a week to 510 hours. In respect to freedom in choice of studies, the freshmen gained access to several departments from which they had previously been excluded; namely, Spanish, Italian, and music. President Eliot holds that it is to the advantage of every department that its elementary studies be open to freshmen, because otherwise the advanced courses of the department might not be reached in due season. In respect to co-ordination of courses, there was an entire recasting of the whole set of courses in physics, with the result of securing a better sequence of subjects and a more complete covering of the ground. Additional facilities were afforded for taking up advanced study and research in German and in Romance philology.

The *morale* of the college has been favorably affected by several causes. The voluntary method in the religious services gives satisfaction to teachers and students. "It meant the permanent removal of the question of conscience, and the drying-up of a constant source of irritation and ill feeling, and the reparation of what many believed to be a grave injury to religion, and the establishment at the heart of the university of a fresh, strong influence for good." Under a new regulation, also, the instructors have the power to exclude from their courses any students who neglect the work required of them. This power has been extensively used, and as a result the discipline and the progress of the students have improved. The question of athletics has been settled to the satisfaction of every member of the university; and Mr. Eliot adds of the faculty, "that they hold that dyspepsia is less tolerable than a stiffened knee or thumb, and that effeminacy and luxury are even worse evils than brutality." We notice, also, an interesting remark in this report regarding the physical condition of students holding scholarships. It seems that the college is now paying out more than fifty thousand dollars a year to students who need aid to complete their education. Heretofore it has been usual to pay no attention to the bodily condition of the recipients of this beneficiary aid, and it is believed that these recipients fall below the average of the whole body of students in health and vitality. It is now provided that holders of scholarships shall present themselves twice in the year to the director of the gymnasium to be examined as to their physical condition, and to receive suggestions as to the care of their health. The summer courses, the library, and the professional schools are all touched upon, and valuable information is contained in the appendices.

SCIENCE AND THE DICTIONARY.

ONE of the most important accompaniments of the progress of science, indeed an essential factor in it, is the increase of its vocabulary. Every advance in accurate observation, discovery, analysis, or constructive theory, brings with it a new term, or, more often, a group of terms. This multiplication of words is largely inevitable. The new things must, of course, generally receive new names, and the new ideas will not always fit into the frames of association in which the old words are set. The scientific demand for precision and brevity must be satisfied even if linguistic purity suffers. It thus happens that every year the language of science receives a large addition which students of science must understand and use. How very large this increment is, it is difficult, even for those who are familiar with several departments of science, to appreciate. Moreover, the process of growth does not stop with what is necessary. Unfortunately, the liberty which in many cases must be taken with the language has led many reputable scientific men to feel that they are free to do what they please with it, in any case. The result is a vast number of coinages which might have been dispensed with, but which must be learned and remembered, since they often become current through the reputation of their inventors. The number of such words increases at the rate of probably several thousand a year.

To this increment through direct coinage must also be added the numerous, and not less significant, specializations and enlargements of the meaning of established and even common words, such as "energy" and "potential." Every movement in science unsettles much that has been done before, and of this continuous re-adjustment its language is a true reflection.

It is obvious that at this point science can receive a great deal of help from competent lexicographic aid. While the dictionary is not, in many respects, an adequate exponent of scientific knowledge, it may be an invaluable record of the greater number of the elements or details of that knowledge. Its aim is, of course, necessarily to state merely what is or has been in the language it describes, not what scientifically ought to have been; but, if it is accurately and intelligently performed, this historical labor approaches in its value to science very near to original work. It is true, also, that the utility of the ordinary dictionary is limited by the narrowness of its definitions and the formalism which marks its treatment of its material; but these defects are largely conventional, and it is quite possible for an editor who understands the wants to be met, and who has the necessary disregard of traditions, to model a dictionary which will satisfy every reasonable scientific demand. In a word, the impossibility now felt of keeping track of the linguistic development not only of science as a whole, but even of one specialty, and the difficulty of guarding even established words from misuse or abuse, make the construction of a dictionary which will not only record the entire vocabulary of the sciences, but will record it and define it so fully and accurately as to conform to the needs of scientific men, one of the most urgent requirements of the time. It is therefore worthy of note that the attempt has been made in this country, and by American scientists, to produce a book of this kind. It is announced that the "Century Dictionary," which has been for some years preparing, under the editorship of Professor W. D. Whitney, is to be not merely a complete general and historical dictionary of common English, but also an equally complete dictionary of technical terms; and that this technical material, which has been obtained by searching all branches of scientific literature, has been put into shape by competent specialists, who have had in mind the necessities of their fellow-craftsmen, as well as the wants of laymen. It appears, thus, that an effort is seriously making to embody for the first time comprehensively, in lexicographic form, the scientific spirit and work of the nineteenth century; and while it is to be expected that the most direct result of the attempt will be the promoting of popular intelligence, it is also to be expected — from the reputation of the distinguished editor-in-chief and of his co-laborers, among whom are Professor J. D. Whitney, Professor E. S. Dana, Dr. Sereno Watson, Dr. Lester F. Ward, Professor C. S. Peirce, Professor T. C. Mendenhall, Professor R. H. Thurston, Dr. Elliott Coues, Professor Theodore Gill, and many others — that the interests of pure science will not be neglected.

SPEECH AND ALPHABETICS.¹

I HAVE never practised offhand utterance on any subject. I have always had to write what I had to say; so that I have enslaved myself to a method which I cannot now hope to change. The method, however, has this advantage; namely, that it keeps one to the point, prevents rambling of thought and vagueness of expression, and so enables one to be exact to his intention, both in outline and detail. I do not mean that an address on such an occasion as the present should be read, but that, however little used, the presence of paper secures presence of mind. On the whole, therefore, I do not know that I should greatly care to change my method, even if I could.

We are called on to say something on the subject that most interests our thoughts. This requirement will, of course, furnish excuse for whatever of egotism there may seem to be in our response to the call. For my part, I can say, that, while I have from time to time ridden an occasional hobby, there has always been one subject of abiding interest which has persisted in maintaining prominence in my thoughts from my earliest days until now. That subject has been "Speech and Alphabetics."

I had hereditary leanings to the profession of teacher of vocal physiology, which no doubt influenced the current even of my boyish thoughts; and when, in 1841, I began to prepare myself for independent work, I sought to supplement what I may call the family knowledge which I possessed, by the study of all available books on the subject. I found, however, that but little assistance was to be obtained from this source; for the art of treating defects of speech had been shrouded in secrecy by nearly all its practitioners. My father was, in fact, the first to repudiate occult methods in the cure of stammering; and to practise his system openly. At the time I speak of, there did not exist in print, so far as I could discover, any precise directory for the processes of articulation. I aimed at teaching these processes, but could not find a single work that gave specific guidance as to what to do, or how to do it, in any given case. Under these circumstances, I had to investigate from my own organs and the organs of my pupils. I had many pupils, exhibiting wide varieties of defects and peculiarities, and the observations on these by day became the study of the night. I may add, however, that my night-work never interfered with day-work; that it invariably terminated not later than two in the morning, while the day-work invariably began not later than ten. This was very nearly the philosopher's division of the twenty-four hours, — one third for work, one third for recreation, and one third for rest. But my work and recreation were inseparable. Work was one half recreation, and recreation one half work, on the principle that "the labor we delight in physics pain," or, in other words, is recreative.

Years of this pleasurable devotion to one subject ultimately developed what I had sought in vain to find as a legacy from professional predecessors. In 1849 the first results of my labors were published under the title of "A New Elucidation of the Principles of Speech and Elocution," forming the kind of directory which I had desiderated before I began to teach. But this work was far from exhausting my phonetic material, which was still, moreover, increasing. I had become experimentally acquainted with a category of sounds far exceeding those in any language. The peculiar elements in Gaelic, Welsh, Scotch and Irish dialects, provincial and metropolitan English, American English, French, German, etc., — as well as those accidental sounds produced by stammerers, lispers, persons with cleft palate, deaf-mutes, etc., — were familiar to my ear and my vocal organs; and I sought long to incorporate them into one phonetic scheme, where each sound should find its place in due relation to every other sound. The process was the converse of that which had been tried for the collation of a universal alphabet. Eminent linguists had endeavored to collect from all known languages the sounds of each, and from these to frame an alphabet by which all tongues might be uniformly written. But no success had attended the efforts, because the identities and differences among the elements could not be satisfactorily determined. At a conference held in 1854, the object thus aimed at was finally abandoned, and declared to be impossible.

¹ Address by Professor A. Melville Bell, delivered in Washington, D.C., Jan. 28, 1889.

A different basis, however, seemed to me to promise a different result. My aim was to find a physiological instead of a linguistic basis for the desired universal alphabet. I therefore sketched out mouth-regions, divided as it were by lines of latitude and longitude, and endeavored to locate in my chart every sound which I could form or which I could distinguish, whether linguistic or not, so as to bring under review all the varieties that could be produced by the organs of speech. From such a category, I reasoned, the phonetic elements of any and every language might undoubtedly be selected and identified. The undertaking was an arduous one, filling up the night-work hours of many years; but it was at last accomplished, in the system of "Visible Speech" published in 1867.

Naturally, you will perceive, some aspect of my life-topic must still be one of the principal subjects of my thoughts. "Visible Speech" furnishes, in a universal alphabet, the necessary vehicle of a universal language, whenever, if ever, such a bond of human brotherhood shall become an accomplished fact. In the mean time, the system, as an educational implement, performs services both novel and valuable: so I might leave it now out of my thoughts. But I have recently been invited, from an influential quarter, to prepare a popular manual on the subject; and, in working at this, I have developed some new points, which will, I think, add greatly to the scientific value of the system.

The phonetics of our own language have lately claimed my chief attention. Our words have settled into forms irregular, incongruous, and bristling with difficulties to the learner. Every lover of the English tongue must wish that some means should be adopted to render it more easy of acquirement. To us who have mastered the difficulties, each word has, by association, become a thought-picture, of which every letter is a necessary part; and we look upon any disturbance of the orthography to which we are accustomed as we would upon distortion in a drawing. What is called "spelling-reform" is therefore, to perhaps nine persons out of ten, an abomination. If no other means were possible to lessen the labor of learning to read, the objectors to spelling-reform would no doubt yield to the inevitable, and lay aside prejudices and predilections from philanthropic motives; but they cannot be asked to do so while any method remains for obviating the tyro's difficulties without offending the educated, by changing the aspect of our literature.

Thinking on this subject, the idea occurred to let spelling alone, and make a perfectly phonetic version of our common alphabet by limiting each letter to its one most usual sound, discarding unnecessary letters, and designing new letters for unrepresented sounds, so as to form a separate initiatory system for children and foreigners. One primary object was to preserve such a resemblance to ordinary letters as might enable any person to read the new as readily as he does the old. By means of the amended alphabet, the time of learning to read may be reduced to a fraction of that required with common letters, while the exact sound of every word is deduced from the writing of the word itself.

There can be no doubt that a child, or a foreigner, who has learned to read from phonetic letters, will, with little or no further instruction, read also from common letters; and he will learn spelling by the mere contrast with phonetic writing. Spelling is thus always learned pictorially, by the eye, and not mentally, by rule.

One other point. English grammar, as compared with other grammars, is so simple that any alteration in it can scarcely be considered necessary; nevertheless the few existing irregularities may be removed from initiatory books without affecting standard English. I have pointed out elsewhere how this may be done.

English is already the most widely used of all tongues; and the adoption of the amended alphabet will facilitate its diffusion, so that it may speedily become the general medium of international communication throughout the world, — in briefer phrase, world-English.

Interest is hard to be aroused, except when some selfish object is to be attained. We have no personal benefits to be derived from the system which I advocate; but coming generations have, and so has all the outer world. Indifference is not a proper mental attitude in reference to such a subject. National pride, if no higher motive, should urge to effort, and liberality in furtherance of effort,

to render more perfect and more easily accessible, at home and abroad, our noble language and our glorious literature.

Now, I have not only told you the subject that most interests me, but explained the origin of my interest in it, and endeavored to excite your interest in it also. Pardon so much use of the first person. The narrative could not be cast in another mould.

SOMETHING ABOUT TORNADES.¹

WHAT are the local signs of conditions favorable to the formation of tornadoes? 1. The prevalence of southerly winds, with a gradual but continued increase of heat and moisture; 2. A sultry and extremely oppressive condition of the atmosphere, which is sometimes characterized as "sticky," or so quiet as to call forth the remark that "there is not a breath of air stirring;" 3. The form, motion, character of development, and place of formation, of clouds. The sudden appearance of ominous clouds, first in the south-west, and then almost immediately in the north-west and north, is sufficient to attract the attention of the most casual observer. In nearly all instances, these premonitory clouds are unlike the ordinary formation which signifies rain, and perhaps a thunder-storm. If the clouds are light, they resemble smoke rising from a burning building; if dark, they present a deep greenish hue, which appears to increase in intensity as the storm advances. Sometimes these dark clouds appear as densely black masses of smoke, rolling upward from the chimney of an engine. The motions of the clouds are peculiar, in that they appear to be rushing from every quarter towards a common centre, making the incipient stages of a gyrotory motion in the cloud region. The next step in the progress of development is the appearance of a small darting tongue of cloud, which suddenly proceeds downward from the centre of commotion, and ultimately reaches the earth as the full-fledged funnel-shaped tornado-cloud.

This brings us to consider what are the signs of its approach. The tornado-cloud is, of course, not visible from all directions while sweeping the earth. The limit of vision is necessarily greater in some cases than in others, depending upon the topography of the intervening country. Where the funnel-cloud cannot be seen, its existence can readily be distinguished by the peculiar roaring noise which is likened to the rumbling of distant thunder, or the approach of a heavy train of cars. The noise is said to resemble the "sighing of the wind through the forest." As the storm approaches nearer, the sound increases in intensity until the final crash of the elements, which comes with the suddenness of an explosion. The noise is sufficiently peculiar and distinct to create an alarm, and, as a means of warning, must not be ignored. A few moments before the assault there is a death-like stillness in the air. The observer's eye catches the absence of any movement in the leaves upon the trees, which a moment before danced in a gentle wind. The ominous silence portends grave results, and requires that no time be lost in seeking the most perfect means of safety.

The form of the tornado-cloud in individual cases is somewhat variable; but it always tapers from the top downward, the smaller end being nearest the earth. It is described by eye-witnesses as resembling an "elephant's trunk," "balloon-shaped," "egg-shaped," "basket-shaped," etc. While passing along its path, the cloud is characterized by four distinct motions, which may be designated as (1) the "progressive motion," generally from some point in the south-west quadrant to some point in the north-east quadrant; (2) the "whirling or gyrotory motion," always from right to left, or contrary to the movements of the hands of a watch with the face upward; (3) the "curvilinear motion," where frequently the cloud rises from the earth, breaking the continuity of its path for a distance of several rods to as many miles, then returns suddenly to the earth with renewed energy, continuing its violence as before; and (4) the "oscillatory motion," a swaying from side to side of the central line of cloud movement. (This motion is sometimes quite sudden, but generally it is a moderately slow motion, and easily identified: the regularity of it depends upon the frequency and severity of the indraughts of air from the south side of the storm's path into the vortex of the cloud).

¹ Portion of a paper read before the National Geographic Society of Washington, Nov. 16, 1888, by J. P. Finley, continued from *Science*, No. 313.

It is important here to state that the south or right-hand side of the tornado is the most dangerous part of the storm, as it is also in the case of the cyclone. On this side the inflow of air toward the vortex coincides both with the progressive motion of the tornado and with the general easterly movement of the "low," thereby increasing the velocity of the southerly currents. On the north or left-hand side of the tornado the incurving winds oppose the direction of the currents advancing to the vortex, and therefore the force of the wind is very much less on this side: it is therefore the safest side of the storm. The tornado-cloud is swept along by the general currents prevailing in the south-east quadrant of the "low," and whatever may suddenly affect these movements will also extend its influence to the tornado-cloud, and thus increase or diminish its gyrations, sometimes to the extent of withdrawing the cloud entirely from the earth. The tornado continues in the full manifestation of its power until the force arising from the gyrations is no longer adequate to keep the pressure and temperature in the vortex low enough to cause condensation; and therefore the lower part of the cloud vanishes first, the decrease of power continuing until nothing appears on the funnel, and a dark, irregular mass of cloud marks the spot from which the spout had previously depended.

"Windfalls" are the tracks of tornadoes through forests, as shown by the prostrated and confused masses of timber. In many cases there remain but the skeletons of these ruins, and their location is known only to Indians, trappers, hunters, and surveyors. There is not a State east of the Rocky Mountains that has escaped these serrated tracks through its forests, and the record of their occurrence will in many cases be found upon the plats of the early State surveys. Windfalls both of recent and of very early date are still to be found in the forests east of the Mississippi. The late Professor I. A. Lapham of Milwaukee, Wis., attached to the signal corps in 1870-72, made, in the latter year, a very exhaustive and interesting report on the windfalls of Wisconsin. As the result of a very careful examination of the plats of public surveys made within the State, he discovered and marked upon a chart the location and approximate length of path of three hundred and sixty windfalls or tornadoes.

The successful protection of life depends upon the position and surroundings of the observer on the approach of the tornado, the character of motion possessed by the tornado-cloud at the time, the width of the path of the storm, and the velocity with which it is moving.

The following precautions have been determined upon as the result of careful investigation, observation, and experience: 1. The south side is the dangerous portion of the tornado, the north side is the safe portion. 2. In the open country, never undertake to escape from a tornado-cloud without first making sure of the points of the compass, and that the direction which you propose to take is in a line at right angles to the path of the advancing cloud. 3. If the cloud is moving to the north-east, then the line of escape is to the north-west; if to the east, then to the north. Stand facing the advancing cloud in the direct line of its approach, and the safe side is always to the right. 4. To make escape certain, the tornado-cloud should be about three-fourths of a mile distant. This gives the observer a momentary chance to ascertain the character of motion it possesses, the velocity of progression, the width of the path, and the points of the compass. These estimates must of necessity be approximate, but can be made sufficiently accurate to be depended upon. At a greater distance than three-fourths of a mile, it would be difficult, in most cases, for the observer to obtain this information with any degree of satisfaction, unless the atmosphere was clear, and the cloud advancing over the open prairie.

A frame building is safer than one built of brick or stone. The former is more elastic, and holds together longer. The latter goes down in the first crash, and the *débris* is whirled into a heap in the centre of the foundation. This is especially the case where a brick or stone building stands alone. In a block of such buildings, one structure supports another, and there is not quite so much danger of entire destruction. In any event, however, the brick or stone building is the most dangerous, because it so readily crumbles and separates into falling masses, that the inmates are never safe from injury.

In a frame structure the safest place is in the cellar, but in a brick or stone structure it is the most dangerous. In the former case, if the building is destroyed, it is invariably carried away from the foundation. In the latter case the cellar is filled with *débris*.

The safest building to construct is one made entirely of wood, with a "barn frame," and not exceeding one story and a half in height. Where several buildings are connected together in a row, the height may be increased one or more stories with safety. No structure that rises above the earth, however made, can resist the violence of the tornado, and therefore no building is safe as property, or as a resort to protect life. Under all circumstances, whether in a building or in a cellar, refrain from taking a position in a north-east room, in a north-east corner, in an east room, or against an east wall.

The tornado-cave offers absolute security to life and limb, and nothing can replace it for that purpose. This retreat may be constructed as a cellar-cave or as a "dug-out." In the former case an excavation is made in the west wall of the cellar, on a level with the floor of it, and carried under ground until a sufficient distance is reached to provide comfortable quarters for those who propose to occupy the cave. The overhanging roof must be supported by heavy timbers, and then arched over with masonry of brick or stone. This extra precaution concerning the roof is necessary to provide against any serious damage to it by falling timbers or heavy masses of *débris*. The excavation is made into the west wall, because the storm, always approaching from the west, will carry the *débris* away from that side. But even this favorable position does not preclude the probability of *débris* being thrown upon the cave by the whirling currents of the vortex. The extra care bestowed upon the roof is money and time well spent. Careful attention should be given to ventilation and drainage, and to making the retreat in every way as convenient and comfortable as possible. The extent to which this suggestion can be complied with will depend upon the pecuniary ability of the person concerned.

The "dug-out" is a tornado-cave, not necessarily connected with any building. The results to be secured are the same as those derived from the use of the "cellar-cave." The cost of a properly constructed tornado-cave, including material and labor, will range according to the quality, character, and strength of the material with which it is built, together with the price of labor, from a hundred and fifty to three hundred and fifty dollars. Such a cave will comfortably accommodate ten persons.

The rush of air into the tornado's vortex, and therefore the violence of the wind, depends upon the difference of barometric pressure between the inside and the outside of the storm. This difference has been observed to be nearly three inches, and may be very much more, for observations have never been made in the centre of the vortex. A gradient of three inches, however, will give a velocity of 323 miles per hour, which will exert a pressure of about 260 pounds per square foot against a surface exposed at right angles to the direction of the wind.

The explosive force of confined air in a tornado is enormously great; and frequently it is to this energy, rather than to the direct force of the wind, that the destruction of buildings is due. As a tornado-cloud passes over a building, if the air within is confined by closed doors and windows, and cannot readily escape, the explosive force, due to a very great difference in tension between the air inside and outside of the building, bursts asunder the walls, and throws the roof upward to a considerable distance. Eye-witnesses state that under such circumstances roofs have been uplifted a distance of five hundred feet. Cellar-doors have been blown away from their fastenings in the face of a strong wind coming directly against them, and corks have been blown out of empty bottles by the sudden expansion of the air within them. Many almost incredible instances of extraordinary violence by the explosive force of tornadoes could be given, but want of space forbids more than this general reference to such manifestations of the tornado's power.

There is no fact or record to show that an electrical discharge, or any manifestation of atmospheric electricity, ever directly and entirely destroyed a large stone or frame building; ever lifted a locomotive from its track; ever carried an iron bridge from its foundation, and twisted the framework into a shapeless mass; ever

rolled a boulder from its bed in the ground; ever embedded one piece of timber into another, after having carried the former several hundred yards in the air; ever carried bedding and clothing in the air for miles; ever elevated to considerable heights in the air, columns of water from ponds, lakes, and rivers; ever lifted animals from the earth and carried them over buildings; ever drew the water from a cistern; ever twisted a tree from its stump; ever turned a building upside down, or end for end, without otherwise injuring it.

Any method of reasoning which assigns tornado-development to planetary influence is, equally with the electrical theory of their origin, without foundation. We have but to realize that in the formation of the tornado, and other local storms of a similar character, the entire action of all the forces involved, even in the energy of the sun's heat, is embraced in that portion of the atmosphere within from two to three miles of the earth's surface.

Any influence emanating from the movements, conjunctions, or other periodical mutations of the heavenly bodies, distant hundreds of thousands and millions of miles, can only reach an infinitesimal amount, and is entirely inappreciable in its effects upon the atmosphere to produce local or general disturbances, especially near the earth.

It has been asserted that the conditions which give rise to the formation of the tornado-cloud result from the effect upon the atmosphere of the mere revolution of the planets in their orbits; that the circular movements in the atmosphere are propagated and continued by such influences. The effect is likened to that which would result from the whirling in different directions, in a large vessel of water, of several globes attached to the same spindle. Upon withdrawing the globes, after a number of revolutions, the surface of the water will be found covered with a network of eddies. The inherent fault of this simile is the fact, that, while the illustration provides for the circular movement of the bodies within the medium which is set in motion to give the characteristic whirls or eddies, the subject of illustration, the planets, perform their revolutions, not in the atmosphere (the medium to be set in motion), but millions of miles away from it, in another medium, concerning which little is known. The failure properly to apply the method of reasoning by analogy often leads the novice into making the most ridiculous assumptions. It would be more reasonable to assume that the revolution of the planets gave rise to the great disturbances of the atmosphere, embracing extended regions of country, which are known on the weather-map as "highs" and "lows;" but even here the same difficulties operate, although not so extravagantly as in the case of the tornado, with the narrow path of a hundred yards or more.

To forecast successfully the time and place of any atmospheric phenomenon is a difficult matter, largely in proportion to the area of country brought under the influence of the particular disturbance. There are, of course, other elements which enter into the calculation to render the problem, except under the most favorable circumstances, an extremely complicated one, where the accuracy of results is demanded. It is well known that the tornado has the most circumscribed area of all storms, while its violence has no equal in the entire range of meteorological phenomena.

A large amount of field-work, and instrumental and general observations extending over many years, relating to the conditions of formation of this peculiar class of storms in every part of the country where they were found to occur, was necessary as a foundation upon which to base investigations as to the origin, mode of development, and means of prognostication. I began this work, in addition to other duties, in 1879, under directions of the chief signal officer. The first field-work was done in that year, the second in 1882, and the third in 1885. Various reports were prepared and published concerning the development of particular storms, the origin and general characteristics of tornadoes, and the relation of tornado regions to areas of low pressure.

It was found that tornadoes generally occurred at a certain time of day; generally moved in a certain direction; were generally preceded by certain conditions of wind direction and velocity, and by a certain gradient of temperature; generally occurred in connection with a well-defined area of low pressure, and with a "low" of certain form and trend; and generally occurred in a certain

quadrant (south-east) of the low-pressure area, at a certain distance from the centre of the "low" as marked on the weather-map, in certain regions of the country and in certain months of the year, and in groups having parallel paths of progression and at distances between of but a few miles.

Official tornado-predictions began at the Signal Office, experimentally, on the 10th of March, 1884, and were made twice daily at 7 A.M. and 3 P.M., Washington time. The predictions were for certain districts, that portion of the United States embraced between the 77th and 102d meridians being divided into eighteen sections, with arbitrary boundaries. These prognostications terminated on Sept. 20, 1885; and during the season embraced by the work, all of the well-defined and most destructive tornadoes were predicted for the districts within which they occurred, from five to eight hours in advance of the reported time of their appearance.

After May 10, 1886 (the following year), the official predictions were announced to the public in accordance with the following order of the chief signal officer: "The indications officer will give special attention to conditions favorable to the development of severe local storms and tornadoes. When the reports justify the prediction of these storms, they will form a part of the general indications, the prediction to be that conditions are favorable for the occurrence of severe local storms or tornadoes, giving the names of the States where such storms are expected to occur."

It will be observed, that, upon deciding to make tornado-predictions part of the general indications issued daily to the public, the character of the districts was changed from those determined by arbitrary divisions, to those designated by State lines; in other words, the States themselves. Commencing July 1, 1886, a special chart (No. 5, Dew-Point and Local Storm Chart) was made up daily in the indications room of the Signal Office to furnish information from which tornado-predictions could be made. This chart was discontinued on July 1, 1888, and replaced by the general weather-chart from which the regular indications are made. Since Sept. 20, 1885, no official verifications of local storm-predictions have been made, but the results observed from the combined indications are in a measure satisfactory.

Personally, I am of the opinion that the forecasting of conditions favorable to the development of tornadoes, and designating the quadrant of a State in which such conditions shall give rise to local signs that the inhabitants of that section can rely upon, are entirely practicable. By this admission I do not mean to convey the idea that the exact path of the funnel-shaped cloud can be indicated in the despatch, for that would be impossible except by chance. The average width of the tornado-track is only a few hundred yards; and several of these storms may occur in the same county, with entirely independent paths of destruction, and distinct cloud-formations.

It doubtless appears that the quadrant of a State, especially the larger ones, is a very extensive area to cover with a single tornado-prediction; but the fact must not be overlooked, that, where the conditions are favorable for tornadoes, storms having various degrees of tornado violence occur here and there over a very large section of country. Therefore the scheme of local storm-predictions for State quadrants would seem to possess the elements of success; for, while the peculiar funnel-shaped cloud might not appear, the conditions would be such that local storms of great violence would occur, and destruction to life and property ensue.

Although, of course, the area here indicated is quite variable in extent, yet it possesses the decided advantages of definiteness, familiarity to the people who are interested, and brevity of expression in rendering a concise despatch. The local signs of tornado-development are certain, easily observed, and well defined. With the people well informed on these points, and there is no reason why they should not be, the prediction of conditions favorable to local storms, issued from some central meteorological office, would, if successful, supplement the local signs with beneficial results. Failures in the official predictions would not only bring out more distinctly the importance and reliability of local signs, thus creating an interest in their careful observance, but would obviate the occurrence of serious results when wrong predictions were made, as the people would test their trustworthiness by appeal to the "local signs."

With the appearance of every new problem in science, especially if its solution involves the welfare of mankind or any great number of people, there is made the most strenuous effort to obtain deductive results, without due regard to proper methods of investigation. This is all quite in accordance with the inclination of human nature frequently to want without reason, but the true scientist knows that such demands cannot be complied with in safety.

People clamor for adequate means to destroy the tornado-cloud by a single blow, sometimes that can act with the rapidity of the electric shock; and because the article cannot be supplied in order, in quantity, and in style, to suit customers, we are informed by some critics that investigation thus far has been fruitless, and that our efforts to expose the nature and origin of tornadoes are the mere vapourings of a vivid imagination.

In this age of inventions and glittering geniuses, it is not surprising that the sufferings and the necessities of the tornado-stricken people have received attention; but, as usual, such attention has been more to the profit of the scheme and schemers than to the advantage of those whose credulity made them the victims of an overweening confidence. The festive and irrepressible lightning-rod pedlar has appeared upon the scene, and offers with great gusto a beautifully wrought metallic rod, to be attached to buildings with gilt fastenings, terminating near the chimney or cupola with a resplendent brass rooster or other decoration, which, while serving the purpose of a wind-indicator, is, together with the mysterious rod connecting it with the earth, a perfect protection against the tornado-cloud. How the result is obtained is a secret of the inventor. The purchaser must not inquire into the nature of this mystery, as his success with the venture depends solely upon an abiding faith and the requisite shenels.

There are other plans and devices deserving of a little more recognition, but they are wholly wanting in the essentials that shall make them reliable and capable of practical application at the moment of supreme danger. Among these may be mentioned (1) an arrangement to explode an underground magazine by electricity when the tornado-cloud approaches a town, a mill, or any group of buildings to be protected, the explosion to take place while the cloud is passing over the magazine; (2) an arrangement of high poles, electrically connected with each other and the earth, and covering about an acre of ground, the top of the poles to be furnished with long, sharp metallic points, so as to draw off the electricity of the tornado-cloud, and thus dissipate its energy at once, upon reaching the field of poles; (3) a cable to anchor a building safely against the fiercest tornado, and an insurance policy to cover all damages that may occur from the cable giving way; (4) an arrangement to keep kegs of gunpowder in a properly protected place to the south-west of the building, and, upon the approach of the tornado-cloud, courageous men to take out the kegs and place them in the path of the approaching cloud, the powder to be fired at the right time to destroy the cloud; (5) an arrangement to construct immense stand-pipes of heavy wrought iron, about five hundred feet high and one hundred feet in diameter, these pipes to be placed upon heavy masonry piers about ten feet high, and so constructed as to permit a free circulation of the air underneath, and upward through the centre of the pipe. The plan involves the erection of a considerable number of these pipes in the tornado regions, the requisite number to be determined by experience. It is expected that these great pipes will serve as vent-holes for the harmless escape of whirling eddies in the atmosphere, which otherwise might develop into destructive tornadoes. It is further claimed that these pipes may serve to increase the rainfall at any place by causing, artificially, the upward rush of a large volume of air, the moisture contained therein being condensed by the cold of elevation. The initiatory upward movement at the base of the pipe is induced by an open fire built on the ground, within the pipe and near the centre of the base. Of course, the physical principle involved is the upward movement of heated air, and the inrush, at the point of inception, of the surrounding cooler air, thus giving rise to an upward flow of more or less power, according to the amount of heat applied and the volume of air affected.

The limits of this paper will not permit of a critical discussion of the merits of the various mechanical devices for the destruction of the tornado-cloud, or even to mention them all. Suffice it to say,

that the writer is of the belief that all efforts directed toward the accomplishment of the destruction or dissipation of the tornado-cloud by any known and practicable means, will fail of realization.

Mechanical appliances are wholly incapable of successfully coping with the forces of the tornado, which, unlike the whirlwind and waterspout, arises from the unstable state of the atmosphere in the cloud region, where the tornadic gyrations commence, and are afterwards propagated downward to the earth's surface. The tornado is controlled by the operation of forces far above the ground.

A RIVER-PIRATE.

THERE is a little river-pirate in eastern Pennsylvania unsuspected by its rural neighbors. It is in a quiet, well-watered farming district, where the streams, as a rule, are bent only on minding their own business, and not interfering with their fellows; and yet one of them is a confirmed pirate, and goes on unhindered in its robbery.

The pirate is Déer Run, and its victim is the north-east branch of Perkiomen Creek. The head waters of the latter have been captured, and led away from the basin where they were born and passed their youth, and thus diverted to swell the surreptitious vol-

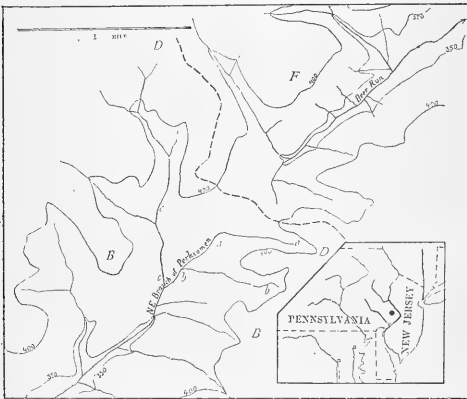

ume of the intruder. The affair has happened in this way. The country hereabout was in ancient times a surface of faint relief, at a lower stand than now, traversed by idle streams; but, in consequence of elevation to a greater altitude, the streams have revived their lost activities, and set to work to sink their channels and open out their valleys in the process of reducing the land to its proper level again, even with the sea; for land finds its level, like water, but more time is required before the level is assumed. The streams that drained the country when it was elevated adopted such faint inequalities as they then found for their first settlement, and have since been engaged in perfecting their courses as best they could, cleaning them out, deepening them, and adapting them most exactly to the best transportation of land-waste. In the processes of adjustment thus called forth, every stream struggling for its own existence, it sometimes has happened that a stream with steep head waters has seized drainage area from the flat-lying head waters of an adjacent basin; because, other things being equal, the waste of the surface is fastest on the steepest slopes, and hence the steeper streams have gnawed more quickly into the land-mass than the flatter ones, and the divide between a pair of contesting streams has consequently been pushed in the direction of the fainter descent.

The abstract possibility of this process cannot be questioned; but one might well hesitate before accusing so innocent-looking a stream as Déer Run of such underhand designs. Yet the evidence of its piracy is too direct to be doubted.

In the first place, the region that the two streams drain has been

accurately surveyed by the Philadelphia Water Department, and the maps thus secured have been published by the Geological Survey of Pennsylvania. The facts of the case are thus brought clearly before the world, after long remaining in unsurveyed obscurity. It is from one sheet of these maps that the accompanying figure has been traced, omitting the wooded areas and dwellings. The smaller map in the corner indicates the location of the district under discussion in the south-eastern corner of Pennsylvania, north of Philadelphia and west of Trenton. In the next place, it is to be noted that the slope of Déer Run from the divide *DD* is twice as steep to the north-east as is that of its victim to the south-west. Déer Run descends sixty feet in a mile at its head; the Perkiomen branch descends only thirty feet in the same distance. Again: it appears that the two streams, flowing on the same line but in opposite directions, both follow the same bed of shaly sandstone in the rock formation (triassic) that underlies the district; there is, therefore, no inequality of structure on the two sides of the divide to determine a difference in the rate of head-water weathering. In so short a distance as a mile or two, it cannot be thought that there is any difference in rainfall or other climatic element of significance; and, if exposure to sunshine be a factor of value in aiding the denudation of a surface by strengthening the diurnal variations of temperature in the soil and increasing the number of winter thaws, this advantage would be with the Perkiomen. Leaving this aside, it appears, that, except for difference of slope, the streams are in similar conditions, and any inequality in their action must be referred to the control that the slopes exert. As the control exerted by the slopes is distinctly in favor of Déer Run, we must conclude, that, if a patient observer should take his stand on the higher ground near by, he would certainly see the divide *DD*, migrating, rather slowly to be sure, to the south-west. After a time the uppermost side-stream of the Perkiomen branch, *aa*, would be tapped by the insidious operations of the pirate; and, powerless to withstand the temptations of a more facile descent, it would turn from its parent to join the volume of its captor. In time another side-stream, *bb*, would be led astray; and thus Déer Run would extend its territory at the expense of its more inert neighbor, and the divide would in time be shifted to *BB*.

Now, it is noticeable that all tributaries thus acquired by the pirate would enter the head of its main channel in a back-handed manner, like the barbs at the point of an arrow, indicating by this abnormal arrangement their early training in accordance with the habits of the Perkiomen family, where they were brought up. But if this process is going on now, we must be persuaded that it has been in operation in earlier times also, and that results of the kind now predicted for the coming ages should already be visible as the product of those gone by. Such is undoubtedly the case. Déer Run bears at its head at least three small side-streams, which still manifest in their directions the clearest indications of Perkiomen habit; and thus it must stand convicted not only of piratical intentions for the future, but of piratical practice in the past.

If the reader should, perchance, be seriously inclined to geographic study, he may find many accounts of this kind of interaction among rivers in the writings of recent authors. Gilbert has considered examples of the process in our Western Territories; Löwl and Philippson have pointed out a number of instances among the rivers of Europe; and Heim has shown how the picturesque little lakes at the head of the Engadine result from the capture of head-water streams by the steep-sloping Maira from the more steady-going Inn. As our intimate acquaintance with the geographic development of our country is furthered by the publication of good topographic maps, we shall undoubtedly find many cases of head-water adjustments. The Atlantic-Mississippi divide, from Pennsylvania to Alabama, should be especially rich in them.

Yet, if what is one man's food is another man's poison, it may be that what is one man's crime is another's virtue. It is only in false allegory that we can blame Déer Run for having taken what once belonged to the Perkiomen; and instead of calling the capture of head waters a piratical act, which at best is but an *ad captandum* term, it should better be regarded as a sharing of another's burden of labor, and a willing assumption by the more active stream of its fair proportion of the work to be done by the whole river system to which it belongs. Instead of gauging the disposition of streams by

likening them to human pirates, and berating Deer Run for what it has done, let us look at the affair from the point of view that a well-disposed river would take.

When this district was lifted from its former lowly estate, the streams found a new task set before them. They at once set to work at it with the best disposition in the world. But, in their immaturity, they accepted without question such guidance as the faint relief of the surface afforded, only to discover later on that the primitive division of territory was unadvisable as a permanency, because it was not adapted to the best accomplishment of the work assigned to them. It is found that a re-adjustment of boundaries, in certain cases, will allow a more economical transportation of land-waste to the sea by better-arranged channels; and, when this becomes apparent to a stream, it at once obeys its new opportunity, whatever force of habit it may theretofore have had. If the ideal of a stream's life were always to persevere in the channel that it at first selects, this readiness to change its course would be called fickleness; but when we perceive that the true ideal of a stream's life is to carry towards the sea its full share of the waste of the land that its river system drains, then we may recognize a virtuous willingness to the performance of duty in this immediate forsaking of an old course, and adoption of a new one, where its work can be done better and quicker. It is the unwisdom of youth that is thus corrected by the better choice of maturity, and many a river has thus improved its early ways. It is undoubtedly true that Deer Run has taken something of what once belonged to the Perkiomen, but it was not seriously that the name of a river-pirate was given to it.

W. M. D.

A POPULAR OBSERVATORY.

A FEW months ago a company was formed in Berlin, the aims and purposes of which are well worth being widely known. The company is named "Urania," and it was established for the purpose of diffusing the interest in the phenomena of nature. Some of the most prominent German scientists are the promoters of this enterprise, the plan of which originated with the distinguished astronomer Professor W. Foerster, who explains the objects of the company as follows: The object of the society is to promote knowledge. In order to inculcate knowledge, it is necessary to educate man to use his mental powers. Therefore institutions for the diffusion of knowledge can only be successful when they try to teach how to use one's mental powers. The society has limited its work principally to astronomical, geographical, and physical phenomena, and for reaching its object has established a great popular observatory, which will be a model for all similar institutions, and publishes a journal, *Himmel und Erde* (Berlin, H. Paetel), which is beautifully printed and illustrated, and gives, in a popular form, reports on astronomical and geographical phenomena and questions.

The popular observatory, of which we reproduce the plan, is divided into three sections, — the rotunda, which forms the foundation of the observatory proper; the large hall, in which instruments and microscopes are exhibited; and the scientific theatre. It is the plan of the founders of this institute to benefit the general public, which embraces uneducated as well as educated persons. Therefore the methods of instruction are varied according to the intelligence and education of the various classes. The scientific theatre forms the lowest stage, on which the results of exact investigations are presented in as attractive a form as possible, in order to give a stimulus to intelligent observation. Solar and lunar eclipses, comets, and meteors are shown to the spectator; the scenery representing beautiful and characteristic landscapes of the parts of the globe in which these phenomena were seen. Thus the desire is aroused to understand the origin of these phenomena, which, only a few centuries ago, were considered as forebodings of evil. These views are accompanied by lectures calling attention to the peculiarities of the phenomena observed on the scene. Among others, a series of astronomical panoramas has been prepared for the purpose of explaining the phenomena of solar eclipses.

At the commencement of the lecture stage represents a landscape near Berlin, at the beginning of the total eclipse of Aug. 19, 1887. At that time unfavorable weather prevented the remarkable

phenomena from being seen, to which attention had been called in newspapers and journals. In the theatre all phenomena of the eclipse will be shown as they would have happened in clear weather. First the landscape will be seen in the light of the early dawn; then the sun will slowly rise on the horizon in the shape of a crescent between purple clouds. The crescent grows narrower rapidly until the dark shadows of the eclipse appear. After two minutes the character of the illumination changes again, and soon the landscape is seen lighted by the clear sun.

While the lecturer explains this phenomenon, the scene changes, and the spectator is transported to a place at some distance from the earth. The huge globe rotates in front of the zodiac, whose signs form the background. The moon, moving through the sunlight, throws its shadow upon the planet, and it is seen crossing the continent of Europe. It is at once understood how the eclipse originated. We continue our journey and reach the moon. We see its desolate mountain ranges. There is deep night in the valleys, while the summits of the mountains are lighted by the rising sun. On the starry sky the earth is seen, giving some light to the parts of the moon over which the sun has not yet risen. On the earth a small dark dot is seen, the point of the shadow of the moon, and its track shows the region where the eclipse is visible. Our journey is continued toward the sun and the planets, the surfaces of which are shown according to the result of the most recent investigations.

A higher stage of instruction is given in the exhibition hall, in which instruments, apparatus, and arrangements of various kinds,

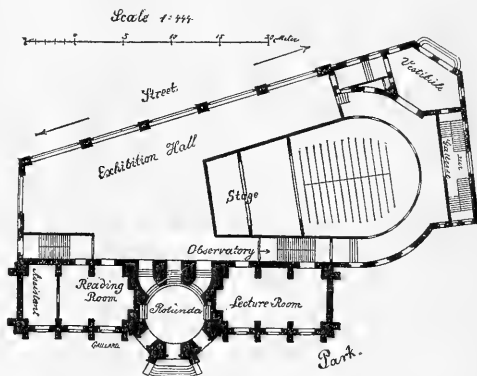

PLAN OF THE POPULAR OBSERVATORY IN BERLIN.

are exhibited, for the purpose of explaining physical phenomena. The composition of sounds, particularly those of speech, are exhibited. The wonderful phenomena of light; its enormous velocity; its composition of numerous colors, which makes nature appear so beautiful; the wonders of the spectroscope, which betrayed the chemical composition of the celestial bodies, and is at present used in many industries, for instance, in the Bessemer process, and in the examination of wines and other liquids regarding their adulteration; the phenomena of polarization and their application in the manufacture of sugar, — all these will be shown and explained to the visitor. In another section of the hall the phenomena of heat will be explained. Models of machines will be exhibited here in great numbers. In still another part of the hall electricity and magnetism, and their extensive applications in manufactures and as a means of rapid communication between distant places, will be shown. Furthermore, fifty microscopes will be placed in this hall, in which the use of this powerful help to scientific investigation will be explained.

Instruments of precision will be exhibited in the same hall. From the latter a staircase leads to the observatory, passing the lecture-room. Here astronomical and microscopical objects will be shown by means of the lantern, and a lecturer will call attention to the characteristic features of each object before it is seen through the telescopes and microscopes.

The observatory of the Urania will be furnished with a number of small instruments; but, in addition to these, it will have the most powerful telescope of Berlin. The lens of the great refractor will be twelve inches in diameter, while the length of the telescope is to be five metres. The dome is eight metres in diameter.

The establishment of this grand institute marks a new departure in the methods of popularizing the natural sciences, and its influence cannot fail to be wholesome. It will educate the masses to an intelligent observation of natural phenomena.

SCIENTIFIC NEWS IN WASHINGTON.

Irrigation in California. — The Nucleus of a "Zoo." — Mounds of Ohio. — Triple Births in the Human Race. — The Talking-Machine in Use. — Where Will It Go Next?

Irrigation in California.

MR. WILLIAM HAMMOND HALL, State engineer of California, addressed the National Geographic Society on Friday evening last, on irrigation, particularly irrigation operations in California. It appears that the first work of this kind within the State, subsequent to that of the early mission fathers, was undertaken by a band of Mormons in the San Bernardino valley, in 1852.

Of the total area of California perhaps one-third is susceptible of sufficient cultivation to sustain a moderately dense population without the aid of irrigation, while one-third will not sustain a sparse population without the aid of irrigation. The principal regions of irrigation in the State are the great interior valley, the southern valley, and the coast plain of the south. By a comparison of the relative amount of rainfall in the older countries of Europe with that of California, and from the peculiar character of the soil, Mr. Hall showed that the relative necessity for the artificial application of water is far greater in California than in these countries, the annual rainfall being much less, and the character of the soil and rate of evaporation quite as unfavorable.

There are in California about 750,000 to 800,000 acres actually irrigated each year, representing what would ordinarily be called an irrigation area of 1,200,000 acres, and there are reasonably within reach of existing canals 2,500,000 acres. The methods of applying water differ very widely with the differing conditions in the various irrigable areas. Much has been done by individual effort in regions where the problem of diverting water from the streams is comparatively easy; but there remain a large number of streams presenting difficult problems, the waters of which can only be utilized by the expenditure of immense capital and the operation of extensive works. Land values in the valley have increased from \$1.25 per acre, prior to the introduction of irrigation, up to \$250 and even higher values, merely by having water rights attached. Much is expected from the investigations on this subject which Congress has recently authorized to be prosecuted.

The Nucleus of a "Zoo."

The Department of Living Animals at the National Museum attracts greater crowds of visitors than can find comfortable standing-room in the animal building, and furnishes one of the strongest arguments that could be made on the necessity of a great national zoological garden. Gifts and deposits have been coming in in such number, that the museum authorities have found it necessary to decline a number of valuable objects, such as a lioness, aoudad, black leopard, camel, and ostrich, because the institution is positively unable to provide for their accommodation. The total number of live animals, birds, and reptiles received up to date is 281. One of the latest arrivals is a great rarity, a Rocky Mountain sheep from north-western Montana, the gift of Mr. George Bird Grinnell, editor of *Forest and Stream*. It has attracted thousands of visitors, and is at present in fine condition. So far as known, it is the only specimen of the species now alive in captivity.

Mounds of Ohio.

At the instance of Dr. Cyrus Thomas, Mr. Reynolds of the Bureau of Ethnology has recently conducted an exploration of one of the most interesting mounds in Ohio; namely, the truncated pyramid associated with the system of enclosures opposite Bourne-

ville, in the Point Creek valley. These enclosures belong to the type comprising true circles and equilateral squares. It proved to be a burial-mound in which two series of circular upright palings, thirty-six feet in diameter, constituted a pre-eminent feature. These indicated successive erection and use, as the mound was from time to time enlarged. The skeletons found were all interred systematically within these wooden palings upon the different sand-seams at different depths. The burials were evidently successive or periodical. None of them could have been intrusive, since the stratification above them was not disturbed. Many interesting specimens, comprising pottery, stone pipes, shell beads, and grooved bone implements, were found deposited with the various skeletons. These and other features that were observed, will, it is said, prove eminently helpful in the solution of the questions relative to the age and builders of these interesting works.

Triple Births in the Human Race.

Some interesting data respecting the frequency of triplets in the human race are being collected and elaborated by Dr. B. Ornstein, late surgeon-general of the Greek army. While on an inspection tour through western Greece, he discovered the fact that triplets are more frequently found there than in any other portion of that kingdom. Great difficulty is experienced, however, respecting information as to the age reached by either or all of the children.

It is desirable therefore, for the purpose of careful study of this subject, to gather information based upon the following: viz., (1) all well-authenticated instances of triple births, and in how many of them the three children reached the age of two (or more) years; (2) the number of cases in which two of the triplets survive one year, or longer, or in which one of them reached the age of one year or more.

Any information pertaining to this subject will be gratefully received by Dr. Ornstein, Athens, Greece; or communications will be forwarded if sent to Dr. W. J. Hoffman, Bureau of Ethnology, Washington, D.C.

The Talking-Machine in Use.

The Geological Survey is the first of the government offices to adopt the graphophone for service. Major Powell is supplied with one of these wonderful little listening and talking machines, and he takes it home with him, and talks to it as the necessity arises or an idea strikes him. In his absence an intelligent boy or girl can evoke a repetition of his monologue, and commit it to paper.

Where Will It Go Next?

The apparatus of the Life-Saving Service which has attracted such deep interest in the Cincinnati Exposition is home again, and safely under shelter. Mr. S. I. Kimball, in charge of the bureau, does not wish to return it to the bare and distant loft of the Treasury Department, where for many years it has been an object of curiosity to visitors, but will await the assignment to it of convenient quarters, where the property can be properly protected.

BOOK-REVIEWS.

The Teachers' Psychology. By A. S. WELCH. New York, E. L. Kellogg & Co. 12°. \$1.25.

THIS work consists of two distinct parts, the first being a treatise on the intellectual faculties, and the second an essay on the proper method of educating them. The author begins with a general view of the mind as a whole, with its three functions of thought, feeling, and action, but afterwards confines himself to the operations of the intellect. This psychological part of the book cannot be pronounced very successful. Mr. Welch's philosophical standpoint seems to be that of the Scottish school; but he cannot be compared with the standard authors of that school in his method of treatment. He takes a surface view of his subject, and, besides, is often lacking in accuracy. Thus, the term "concept," which has always been used to denote a general idea, is employed in this work for both general and particular ideas. Mr. Welch's view of memory is also peculiar, for he includes in it the act of acquiring knowledge as well as the acts of retaining and recalling it. The second part of the work is of a better character, and lays down

certain principles of education to which little exception can be taken. The author holds that education ought to conform to the course of mental development, each study being introduced at the time when the mind is best fitted to pursue it, and hence that studies requiring a high degree of abstraction and close reasoning should not be taken up until after the simpler and more concrete subjects have been mastered. He gives some examples of wrong arrangement of studies, and some suggestions as to the proper mode of teaching certain branches; and, though there is nothing new in his theories, teachers may find his presentation of them worth examining.

AMONG THE PUBLISHERS.

In the February *Wide Awake*, "Forty-eight Hours a Day" will interest all astronomically minded young folk, and their elders as well; "An Old-fashioned Boat" is an interesting chapter in the progress of invention, by Ernest Ingersoll; Mrs. Sallie Joy White, in her chapter on "The Use of the Oven," tells how potatoes are baked in the Boston public schools; Mrs. Goddard Orpen gives the history of the famous Spanish crown pearl, the *Pelegrina*; and Professor Starr, in his geological series, describes some of the gnawings of "The Tooth of Time."

— P. Blakiston, Son, & Co., of Philadelphia, have just ready "A Text-book of Operative Dentistry," by Professor Thomas Fillebrown of the Harvard Dental School, and a second edition of "A Handbook of Diagnosis and Treatment of Skin Diseases," by Dr. Arthur Van Harlingen. They have nearly ready "A Surgical Handbook," by Professor F. Mitchell Caird and Dr. C. Walker Cathcart, of the University of Edinburgh, thoroughly illustrated, and printed in a convenient shape for carrying about.

— W. H. Lowdermilk & Co. will publish in the course of a week "Matthew's Guide for Settlers upon Public Lands of the United States," intended for all having business before the district land office and the Department of the Interior. It is prefaced by a map of the United States, showing the thirteen original States, with the territory subsequently acquired, giving dates and sources of acquisition and the various State and territorial laws regarding real property, and how under United States laws it may be acquired. The author was late assistant chief of the preemption division, General Land Office.

— G. P. Putnam's Sons announce among their earlier publications for 1889 the following: the first volume of the letter-press edition of "The Writings of Washington," edited by Worthington C. Ford, which will be uniform with the previously published sets of "Hamilton" and "Franklin," and be completed in fourteen volumes, limited to 750 sets; a second edition, revised and enlarged, of "The Best Books: a Reader's Guide to the Choice of the Best Available Books in All Departments of Literature, down to 1888," compiled by William Swan Sonnenschein; and "English Wayfarer's Life in the Middle Ages" (fourteenth century), by J. J. Jusserand, translated from the French by Lucy Toulmin Smith. The author has supervised the translation, and has added about a third of new matter, so that the volume differs materially from "La Vie Nomade." The original work was published without illustrations, while this English edition, which is issued in London by T. Fisher Unwin, will be elaborately illustrated from a number of rare designs that have not previously come into publication. Besides these, they announce "A Manual of Oriental Antiquities," including the architecture, sculpture, and industrial arts of Chaldaea, Assyria, Persia, Judea, Phoenicia, and Carthage, by Ernest Babelon, librarian of the Department of Medals and Antiquities in the Bibliothèque Nationale of Paris, translated and enlarged by B. T. A. Evetts of the Department of Egyptian and Assyrian Antiquities of the British Museum, with 250 illustrations; "From Japan to Granada: Sketches of Observation and Inquiry in a Tour round the World in 1887-88," by James Henry Chapin, D.D.; "Business," a practical treatise, by James Platt, reprinted, under arrangement with the author, from the 75th English edition; in the Knickerbocker Nuggets, "Ancient Spanish Ballads," historic and romantic, translated, with notes, by J. G. Lockhart, with sixty illustrations by Allan, Roberts, Harvey, and others, and "The Wit and Wisdom of Sydney Smith;" and in the Questions of the Day

Series, "Outlines of a New Science, a Study of Industrial Conditions," by E. J. Donnell; "Politics as a Duty and as a Career," by Moorfield Storey; "The Plantation Negro as a Freeman," observations upon his character, conditions, and prospects in Virginia, by Philip A. Bruce.

— D. Lothrop Company will publish shortly a story by a New York lady which is said to be a refutation of much of "Robert Elsmere;" and a volume of stories by H. H. Boyesen, called "Vagabond Tales."

— T. Y. Crowell & Co. have in preparation, for the use of schools, an abridged translation of Duruy's admirable "Histoire de France," under the charge of Professor J. F. Jameson of Brown University. They announce for early publication Bourrienne's "Memoirs of Napoleon Bonaparte" in four volumes. They will be handsomely illustrated, and will contain all the critical and biographical and historical notes which add so much to the value of the latest English edition.

— D. Appleton & Co. announce for this week, "Nature and Man," a series of essays, scientific and philosophical, by the late William Benjamin Carpenter, with an introductory memoir by J. Estlin Carpenter, and a portrait of the writer of the essays. The volume also includes a few passages from Dr. Carpenter's earlier writings, prefixed to illustrate the prior stages of his great labors for physiological psychology.

— Henry Holt & Co. will publish shortly a book on the American Revolution, which will furnish not only novel but highly curious matter. In his researches among the French archives, Mr. John Durand, the translator of M. Taine's "French Revolution," found many documents relating to the United States which were of the greatest interest. These papers have been translated by Mr. Durand for the first time, and are edited by him. The work will throw light on various episodes of the American Revolution as well as on the characters of the men who took part in it. The peculiar rôle played by Beaumarchais, the cabal against Washington and Franklin, the secret sessions of the Continental Congress, of which no detailed account has come down to us, together with the social aspects of the country while the Revolution was in progress, will all be presented.

— Harper & Brothers have just published a volume on "The Government of the United States," by W. J. Cocker, A.M., primarily intended as a text-book for public schools, but also calculated to serve as a clear and concise reference manual upon the Constitution. The author presents the influences and conditions which rendered the Constitution a necessity, and describes the powers and limitations of our form of government. The numerous references to more extensive works on the subject make the book a valuable guide in prosecuting further a study of our institutions. Three other books also just ready are: "Modern Science in Bible Lands," by Sir J. W. Dawson, which presents a study of such points of the geology and physical features of Italy, Egypt, and Syria as might throw light on their ancient history, and especially upon the history of the sacred scriptures; "Our English," by Professor Adam S. Hill, which contains novel and sensible suggestions for the proper teaching of the language in schools and colleges, and reviews "Newspaper English," "English in the Novel," "Pulpit English," and "Colloquial English;" also an edition in book form of Charles Reade's "Bible Characters."

— The two latest issues of the *Forum* contain articles by ex-President Andrew D. White of Cornell, on the need of new universities in this country, and particularly on the project for a great central university at Washington. In the January number the writer speaks of the present position of the higher education in America, and of the rapidly increasing demands on the existing universities. He notes the fact that a process of separation is in progress among our institutions of learning, and that a few of them are developing into real universities, while the remainder are tending to become intermediate colleges, holding a position between the universities and the public schools. Real university instruction, he maintains, can only be given in large and liberally endowed institutions, and he believes that we need one or two such institutions of a higher order than any we now have. The most suitable

places for such an institution are New York and Washington. With regard to the former, Columbia College has excellent facilities for supplying the need; but in Mr. White's opinion "the majority of its trustees have long since proved themselves blind to their opportunities." Hence, in a second paper in the February number, he favors the founding of a new university at the national capital, which he thinks the best place in the country for the purpose. The advantages offered by Washington consist partly in the number of able and learned men resident there, whom the university could employ as lecturers or teachers, but still more in the libraries already established in the city, containing over a million volumes, and in the extensive laboratories and other means of investigation maintained by the government. Mr. White believes, that, if the necessary funds could be obtained, a university could be established at Washington which would not only have a powerful influence on the higher education of the country, but would help to raise the tone of political life at the national capital. As to this latter point however, the question arises whether the politicians would not be more likely to exercise a deleterious influence on the students. Besides this article by Mr. White, the February *Forum* contains ten other papers on a great variety of subjects. Mr. W. F. Lilly has one on "The Foundation of Ethics," in which he takes strong ground against the evolutionary theory of ethics as taught by Herbert Spencer, maintaining that it is not only false, but practically pernicious, and that it is already exercising a baneful influence on moral conduct in art, journalism, politics, and other departments of action. What its effects and tendencies are, he promises to state more fully in succeeding articles. Judge Alfred C. Coxe has an important paper on "Relief for the Supreme Court." He alludes to the fact that the Supreme Court of the United States is three or four years behind its docket, and then suggests that the court might catch up with its work if the judges were relieved from circuit duty, which would enable them to sit at Washington two months longer than they do now, and if the practice of reading opinions, which now occupies one day in each week, was abandoned. The other articles we have not space to notice. The *Forum* has taken its place as the foremost magazine for general discussion in the country; but it seems to us, that, if some of the papers it prints were longer and more elaborate, its usefulness would be enhanced.

LETTERS TO THE EDITOR.

*. *Correspondents are requested to be as brief as possible. The writer's name is in all cases required as proof of good faith.
Twenty copies of the number containing his communication will be furnished free to any correspondent on request.

The Baconian Method in Science.

In the nineteenth aphorism of his "Novum Organum," which forms the second part of his "Instauratio Magna," Lord Bacon observes that there are two possible methods for investigating and discovering truth. The one, he says, flies at once from particular observations to axioms of the broadest generality, and from these principles and their immutable verity it scrutinizes and discovers its mediatory axioms or propositions leading to subordinate truths. The other method from particular observations calls forth axioms in a continuous and gradual ascent, so as at last to attain truths of the broadest generality. The former of these methods, he says, is the one in use; the other is new and untried.

The former method is familiarly known as the deductive method. This movement of thought was thoroughly studied and expounded by Aristotle, and is well understood. Lord Bacon opposed his "new and untried" method to the old in this specific feature, that the old or deductive method moved characteristically from the general to the more specific, whereas his new method proceeded from the particular, and advanced, step by step, to the general. Obviously this new movement of his is simply what is known in recent logical science as generalization, — the amplification of a subject-notion or concept. It does not appear from Lord Bacon's writings that he concerned himself at all about the special differences between logical generalization and logical induction. He only insisted that scientific study should in the future unite the two methods, — the old, which moved from the general to the particular, with the new, which moves from the particular to the general.

Nor does he appear ever to distinguish the movement of thought in proper generalization, which confines itself to the subject-notion, from that known in logic as determination, which is the amplification of the attribute-notion; just as the old method did not distinguish between the two movements in the reduction of a concept or notion, — between division, which was applied to subject-notions, and partition, which was applied to attribute-notions.

These movements of thought are fundamental movements, and differ widely from one another in their respective natures and their governing laws. It is as important for the facile and successful prosecution of scientific study in any field of knowledge that they be familiarly known, and be reduced to ready use, as it is for the successful prosecution of mathematical studies that the fundamental or ground rules of arithmetic be mastered for accurate, and, as it were, instinctive application whenever needful. Popular discourse may, perhaps, be pardoned for some looseness in the use of the technical terms and phrases of science; but discussion professedly scientific, and claiming for itself something of the certitude of genuine knowledge, should not ignore these ground rules of scientific knowledge, nor confound them one with another. Widely as they differ, they are alike serviceable for scientific uses; they are of equal validity; they are equally intelligible in their essential nature and in their applications. This is evident from the most cursory exposition.

All complete thought is quantitative. This attribute is revealed among the most fundamental properties of thought. But in quantity, which is but the attribute otherwise known as that of "whole and parts," as we conceive of an object quantitatively when we conceive of it as a whole having parts, extensive or intensive — in quantity there are three, and only three, conceivable relationships of the highest or most generic order; viz., (1) that of whole to part, (2) that of part to whole, and (3) that of part to part. There are, accordingly, only three corresponding movements of thought possible in this relationship: (1) deduction, (2) generalization, and (3) induction. We pass over here the distinctions already indicated as required in accurate science to be made on account of the diverse character of notions as subject-notions or as attribute-notions, and use the familiar designations of the different movements. Deduction moves from whole to part; generalization, from part to whole; induction, from part to part.

Notwithstanding this manifest, and to a large extent familiarly recognized, distinction between these fundamental movements of thought, there is a common loose or faulty use of the terms which properly designate them that is greatly to be deprecated. Particularly is this observable in the case of the term "induction" and its paronyms. For example: "an inductive study of the mind" or "of the Scriptures" is every now and then proposed, when a true inductive study obviously could never have been intended. And even among professedly scientific thinkers are to be detected not infrequently the most shadowy and illusive or even positively false notions of induction and inductive science. Modern science boasts of itself as being characteristically and distinctively inductive, while it would be difficult to find in its work any conscious recognition of the essential character of this fundamental movement of thought. In truth, even logical science has but very imperfectly apprehended it, although the most familiar movement in every-day life. The child induces from one experience from touching the flame what a repetition will cause, and confidently expects to find in the next flower he plucks something of the figure or color or fragrance that he has found in the one he has already gathered. Moreover, the exact character of the movement was scientifically grasped and indicated many centuries ago by the father of logical science. He did not elaborate the exposition of the inductive movement as he did that of the deductive movement; but he exemplified it perfectly in the first book of his "Prior Analytics," c. xxv. (Tauchnitz edition), where from "bileless" and "long-lived" being both attributes of "man," "horse," etc., he infers that the presence of "bileless" involves that of "long-lived." The principle, he says, is this: if any two attributes as parts belong to the same whole, the existence of either one in any case determines the existence of the other. We might state it thus: from any part of a given whole we may infer or induce any complementary part.

LOGICUS.

C. & C. ELECTRIC MOTOR COMPANY.

Electric Motors
FOR
Arc and Incandescent Circuits,
Most Economical Motor
on the Market.
Regulation Perfect.
Motors Designed for all Power
Purposes.

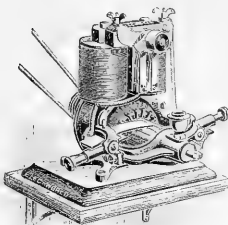

OFFICE and MANUFACTORY:
402 and 404 Greenwich St., New York City.
New England Office, 19 Pearl St., Boston.
Philadelphia Office, 301 Arch St.
Western Office, 139-141 Adams St., Chicago.
Southern Office, 25 Carondelet Street,
NEW ORLEANS.

16 PAGES. **THREE** 16 PAGES.

Hundred Thousand new subscribers for *The Family Journal and Ladies' Companion* wanted. It is the most interesting and instructive paper ever issued. Subscribers will receive during the coming twelve

MONTHS

novels written by American Authors, complete in each three numbers. The story of popular works of fiction will be retold by a novel reader, the most interesting and unique feature ever introduced in any publication, giving the substance of popular and standard books by famous writers in a space easily read by the busiest people. We have engaged

FOR

this work a widely known and popular writer. Comments on Current Events, Fashions, New and Original Ideas and Designs for Ladies' Fancy Work and Household Decoration, Letters from Correspondents and their Answers. The colleges and seminaries of the United States will be treated one each month in an illustrated article, showing the particular advantage of each, cost of attendance, etc. Invaluable to parents having sons or daughters whom they desire should receive the advantages of a higher education than the ordinary school affords. Articles on Painting and Drawing, giving home instruction by a well-known artist. A trial subscription of this elegant paper will be sent to any address, three months,

TEN CENTS.

Liberal pay for literary work adapted to our columns, and for new and original drawings, designs and ideas on any subject which we can use. Premiums List the most complete in the world. We offer inducements to club raisers and agents approached by no other publishing house. The celebrated Gilbert Cut Waist Linings, which we send post paid to any one sending us two yearly subscribers at 60 cents each is alone worth 76 cents.

TRY IT! TRY IT! TRY IT!
and you will become a permanent reader. Address:

John L. Douglass, Publisher,
322 Broadway, N. Y.

WEBSTER

THE BEST INVESTMENT
for the Family, School or Professional Library.



Besides many other valuable features, it contains

A Dictionary

of 118,000 Words, 3000 Engravings,

A Gazetteer of the World

locating and describing 25,000 Places,

A Biographical Dictionary

of nearly 10,000 Noted Persons,

A Dictionary of Fiction

found only in Webster,

All in One Book.

3000 more Words and nearly 2000 more Illustrations than any other American Dictionary.

Sold by all Booksellers. Pamphlet free.
G. & C. MERRIAM & CO., Pub'rs, Springfield, Mass.

Schools.

CONNECTICUT, NEW HAVEN.
MRS. CADY'S SCHOOL FOR YOUNG LADIES.
Prepares for Smith and Wellesley, and admits to Vassar by Certificate. Circulars. Early application necessary.

VERMONT, BURLINGTON.
VERMONT EPISCOPAL INSTITUTE. Boarding School for Boys. Prepares for College or Business. Military drill. Terms moderate. Fifty-seventh half-year opens September 3, 1888. Send for catalogue.
H. H. ROSS, A.M., Principal.

TERRE HAUTE, IND.
ROSE POLYTECHNIC INSTITUTE.—A School of Engineering. Well endowed, well equipped departments of Mechanical and Civil Engineering. Electricity, Chemistry, Drawing. Extensive Shops & Laboratories. Expenses low. For catalogue address T. C. Mendenhall, Pres.

Insurance.

DELAY IS DANGEROUS.

We call attention to the new form of Accident (indemnity) Insurance policies, which are written by the Merchants' Casualty Insurance Association, 21 Park Row, New York City, John S. Purdy, Secretary. These policies cover weekly allowances of from \$10 to \$25, according to occupation, at a cost of only \$6 a year exclusive of the cost to join, which is \$2 payable once only. The public, as a rule, carry life insurance, and the ordinary accident policies issued by companies, paying a sum in case of death, is not so desirable as one of these indemnity policies in case of accidents, which are so plentiful in this fast age with its railroad horrors, fast driving, electric wires and other countless forms of dangero to which the public is constantly exposed. The fact of the Association having no unpaid claims, and its having just passed an examination by the Insurance Department of New York State, shows that the management is liberal with its policy-holders and conservative in its action. The Association also desires to secure energetic Agents in every village and town, to whom territory and favorable terms will be given.

Scientific Apparatus.

J. GRUNOW,

621 Sixth Avenue, New York.

Established 1852.

MAKER OF

Microscope Stands,
Oil Immersion Objectives and Abbe Condensers for Bacterial and Histological work, of Objectives, Camera Lucida and other accessory apparatus.



W. H. WALMSLEY & CO.
SUCCESSORS TO
R. & J. BECK,

1016 Chestnut Street Phila

Microscopes and all Accessories and Apparatus. Photographic and Photo-Micrographic Apparatus and Outfits.

Spectacles, Eye Glasses, Opera and Marine Glasses, etc.

Illustrated Price List mailed free to any address. Mention SCIENCE in corresponding with us.



ZOOLOGY, ANATOMY, PALEONTOLOGY.—We arrange and furnish collections for educational purposes. We have an immense stock of recent shells and fossils; anatomical preparations; models (papier maché) of the human body, divisible, complete, and in separate parts, also parts of mammals, very important for the study of anatomy; also microscopical preparations. Linnaean Institution for Natural History, Berlin, Germany. Our Agent in the U. S., MR. HERMAN ROLLE, 33 Ave. A, New York City, will send specimen catalogues free on application.

E. & H. T. ANTHONY & CO.
591 Broadway, N. Y.

Manufacturers and Importers of

PHOTOGRAPHIC INSTRUMENTS,

Apparatus and Supplies of every

description. Sole proprietors of

the Patent Detective, Fairy, Novel, and Bicycle Cameras, and the

Celebrated Stanley Dry Plates.

Amateur Outfits in great variety, from \$5.00 upward.

Send for Catalogue or call and examine. 22nd More

than 40 years established in this line of business.

MAGIC Stereopticons and the Best Views for Public, Church, Home, and Scientific Exhibitions. Best apparatus, new views. Largest stock. Reduced prices. 24 Years' Practical Experience. Illus. Catalogue Free.

GEO. H. PIERCE,

136 S. Eleventh St., Philadelphia, Pa

IMPROVED OIL LIGHT MAGIC LANTERNS.

Also Lime and Electric Light Apparatus, and mechanical, plain, and fine colored views.

J. B. COLT & CO., Manufacturers,

No. 16 BEEKMAN STREET, NEW YORK.

WHITALL'S PLANISPHERES OF THE STARRY HEAVENS name and locate all Planets, Stars, and Constellations visible at any given minute of time. Every one should possess set, \$5.00; Miniature, 30 cents postage paid. Ask stationer, or address Wm. T. Cooper, Manager, 307 Race St., Philadelphia, Pa.

Arnold,
Constable & Co.
EVENING DRESS FABRICS,
CREPE AND GAZE GRENADINES,
METAL AND BROCADED EFFECTS.
Broadway & 19th St.
New York.



GOOD NEWS TO LADIES.

Greatest inducements ever offered. Now's your time to get up orders for our celebrated Teas and Coffees, and secure a beautiful Gold Band or Moss Rose China Tea Set, Dinner Set, Gilt Band Moss Rose Toilet Set, Watch, Brass Lamp, or Webster's Dictionary. For full particulars address **THE GREAT AMERICAN TEA CO.,** P. O. Box 359, 31 and 33 Vesey St., New York.

Readers of Science

Corresponding with or visiting Advertisers will confer a great favor by mentioning the paper.

REMINGTON



MISS M. E. ORR.

Standard Typewriter



REMINGTON.

WON
GOLD MEDAL.
AND
SILVER MEDAL
FOR
CHAMPIONSHIP OF THE WORLD,

At Toronto, August 13, 1888.

OFFICIAL REPORT.

"On General Writing—law, evidence, and commercial matter—*Miss M. E. Orr won the Gold Medal for the Championship of the World. *Mr. McGurkin won the Silver Medal in the same class."

**Both Miss Orr and Mr. McGurkin used Remington Typewriters.*

WYCKOFF, SEAMANS & BENEDICT,
327 Broadway, N. Y.

A NEW MAGAZINE—THE SWISS CROSS

Devoted to spreading a love of pictures among the people. Edited by **HARLAN H. BALLARD,** President of the Apressiz Association, and succeeding *St. Nicholas* as the official magazine of that body. \$1.00 a year. Sample copy free, or 25 cents for trial subscription for 3 months. **N. D. C. HODGES, PUBLISHER,** 47 Lafayette Place, New York. Mention this paper.

CALIGRAPH

MEDAL AWARDED!

GREATEST SPEED ON RECORD!!

126 words per minute, errors excluded.

T. W. Osborne, winner of international contest at Toronto, wrote on the Caligraph Writing Machine 630 words in five minutes, thus gaining for the Caligraph the championship of the world.

30,000
in
Daily Use.

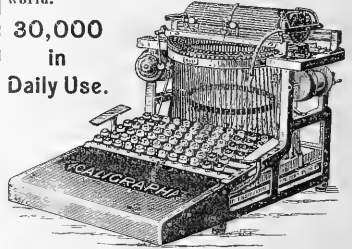

For full and correct account of above test, address **THE AMERICAN WRITING MACHINE CO.,** HARTFORD, CONN.
New York Branch, 237 Broadway.



KIMBALL'S STRAIGHT CUT CIGARETTES.

Unsurpassed in quality. Used by people of refined taste. Highest award at Brussels, 1888. The finest smoking mixtures are of our manufacture. **Fifteen First Prize Medals.** **WM. S. KIMBALL & CO.,** Rochester, N. Y.

Sprague Electric Railway and Motor Company.

For Stationary or Railway Work,
for Mining or Engineering
operations the **SPRAGUE MOTORS**
are unexcelled.

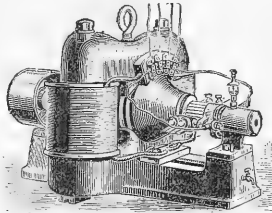

Estimates given for complete
Power Installations.

Send for Circulars and full
Information.

16 and 18 BROAD STREET, NEW YORK.

ELECTRICAL TESTING BUREAU,

Johns Hopkins University, Baltimore, Md.
Resistance Coils and Boxes Compared.
Am meters and Volt meters calibrated.
Condensers standardized.
Primary and Secondary Batteries Tested.
Efficiency of Dynamos and Motors Determined.
Insulation of Cables and Wires Tested.
Etc., Etc.
Circulars describing Methods Used, Prices, Etc., sent on Application.
Address as above.

R. ELLIS & CO.

BUSINESS, HOTEL AND PATENT BROKERS,
AUCTIONEERS, ETC.

No. 176 BROADWAY,

Room 46.

New York.

CLIENTS Advised free of charge.

TO EMPLOYERS.

Having purchased the fixtures, good will, &c. of the **NEW YORK EMPLOYMENT BUREAU** at No. 681 BROADWAY, in this city, we request the patronage of the public in the future. We desire to fill a long-felt want for an employment bureau, where only the best grade of male help is dealt in, and it is our aim to send ONLY such help as is ordered in every instance, and our patrons can rely on us to send strictly first-class help, the references of whom we personally investigate before sending to any one. We simply request a trial, and are convinced that we will give satisfaction in every case. We have on hand help in every branch, which we can send upon receipt of telegram or letter, AND FOR WHICH WE MAKE NO CHARGE TO AN EMPLOYER.

NEW YORK EMPLOYMENT BUREAU,
(AS REORGANIZED).

SCIENCE

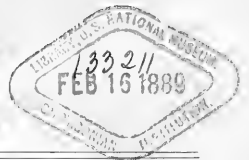

SEVENTH YEAR.
VOL. XIII. No. 315.

NEW YORK, FEBRUARY 15, 1889.

SINGLE COPIES, TEN CENTS.
\$3.50 PER YEAR, IN ADVANCE.

Forty-first Annual Report OF THE PENN MUTUAL LIFE INSURANCE CO. OF PHILADELPHIA.

NET ASSETS,

Jan. 1, 1888.....\$11,827,556 83

RECEIPTS DURING THE YEAR:

For Premiums\$2,640,561 08
For Interest, etc..... 717,464 34 \$3,358,025 42
\$15,185,582 25

DISBURSEMENTS:

Claims by Death.....\$823,324 00
Matured Endowments..... 75,237 00
Surrendered Policies..... 202,002 40
†Premium Abatements..... 519,532 54
Re-Insurance 4,269 99

Total Paid Policy-holders.....\$1,624,365 93
Added to Reserve 1,095,006 00
Taxes and Legal Expenses... \$66,443 00
Salaries, Medical Fees and Office Expenses..... 118,403 98
Commissions to Agents and Rents..... 296,253 08
Agency and other Expenses.. 98,017 21
Advertising, Printing and Supplies..... 25,510 93
Fire Insurance and Office Furniture 4,664 08 \$2,233,658 21

NET ASSETS,

Jan. 1, 1889..... \$12,951,924 04

† Being sums allowed in reduction of collectible premiums.

ASSETS:

City Loans, Railroad and Water Bonds, Bank and other Stocks..... \$5,871,695 16
Real Estate and Ground Rents..... 4,044,729 74
Premiums secured by Policies, etc.... 613,720 04
Loans on Collaterals, etc..... 1,263,745 07
Home Office and Real Estate bought to secure Loans..... 690,494 07
Cash in Trust Companies and on hand.... 467,539 96
Net Ledger Assets, as above, \$12,951,924 04
Net Deferred and Unreported Premiums... 330,277 95
Interest, Due and Accrued, etc..... 89,049 46
Market Value of Stocks, Bonds, etc., and Real Estate over cost..... 416,176 84
Gross Assets, January 1, 1889, \$13,787,428 29

LIABILITIES:

Losses reported, but awaiting Proof \$69,560 00
Reserve at 4 per cent to Re-insure Risks..... 11,507,717 00
Surplus on Life Rate Endowments, and unreported Policies, etc..... 360,943 80
Surplus, 4 per cent basis.... 1,849,207 49 \$13,787,428 29
Surplus at 4 1-2 per cent Pennsylvania Standard (Estimated)..... \$2,521,549 00
New Business for the Year, 5,666 Policies for..... 14,630,744 00
Insurance Outstanding, December 31, 1888, 27,714 Policies for..... 68,372,882 00

TRUSTEES.

William H. Kern,
James O. Pease,
Thomas W. Davis,
Joseph M. P. Price,
Charles Watson,
Ellwood Johnson,
William C. Houston,

Joseph B. Hodgson,
Howard Hinchman,
William H. Rhawn,
Atwood Smith,
John H. Watt,
N. Parker Shortridge,
Richard S. Brock,

Benjamin Allen,
John Scott,
Charles J. Field,
Robert Dornan,
William M. Runk,
R. Allison Muller,
Henry S. Eckert,

Noah A. Plympton,
Benjamin S. Bentley,
Frank Markoe,
Harry F. West,
Lincoln K. Passmore,
George K. Johnson, Jr.

EDWARD M. NEEDLES, President.
HORATIO S. STEPHENS, Vice-President.

HENRY C. BROWN, Sec'y and Treas'r.
JESSE J. BARKER, Actuary.

GUARANTY INVESTMENT COMPANY

CAPITAL \$250,000.

Offices: Atchison, Kan. 191 Broadway, New York. 222 Walnut St., Phila.

Hon. ALBERT H. HORTON (Chief Justice, Kansas Supreme Court), Topeka, Kan., Pres't.

7% Guaranteed Farm Mortgages 7%

The Guaranty Investment Company makes loans upon fertile farms in the choicest portions of Kansas and Nebraska and has adopted the policy of sending a Committee of its Investors each year to examine its loans and methods of business.

The Committee this year consisted of PROF. A. H. BERLIN, Principal of the High School Montrose, Pa., and MAJ. THEODORE L. POOLE, Ex-U. S. Pension Agent, Syracuse, N. Y. Both of these gentlemen are persons of the highest character and have the confidence of the Communities in which they reside.

The Committee has recently returned and has made a very interesting Report upon the general development of Kansas and Nebraska as well as the business of the Company. The Company will be glad to send this Report to any address.

The following names are taken from the long list of Investors in our Mortgages:

(See if Some Friend of Yours is not in the List.)

William A. Cauldwell, 59 Liberty St., N.Y.
 Palmer Cox, 648 Broadway, N.Y.
 Rev. Jos. H. Rylance, D.D., 11 Livingston Place, N.Y.
 Rev. Brady E. Backus, D.D., 360 West 28th St., N.Y.
 Rev. R. M. Somerville, 126 West 45th St., N.Y.
 Dr. Robert A. Murray, 225 West 23d St., N.Y.
 Dr. James P. Tuttle, 136 West 41st St., N.Y.
 H. Edwards Rowland, 218 Fulton St., N.Y.
 Irving H. Tift, Esq., 271 Broadway, N.Y.
 Prof. D. G. Eaton, 55 Pineapple St., Brooklyn, N.Y.
 Dr. E. P. Thwing, 148 St. Marks Ave., Brooklyn, N.Y.
 Dr. C. C. Miles, Greenport, N.Y.
 John V. N. Bergen, Port Jefferson, N.Y.
 Benj. W. Stilwell, Yonkers, N.Y.

R. C. Coleman, Goshen, N.Y.
 Mrs. Samuel Carlisle, Newburg, N.Y.
 Dr. C. C. Bartholomew, Odensburg, N.Y.
 Rev. Nelson Millard, D.D., Rochester, N.Y.
 Rev. Horace G. Hinsdale, D.D., Princeton, N.J.
 Dr. Charles M. Howe, Passaic, N.J.
 George A. Skinner, 5 Railroad Place, Newark, N.J.
 Dr. Edwin M. Howe, 82 Halsey St., Newark, N.J.
 Dr. H. G. Buckingham, Clayton, N.J.
 Dr. Martin Cole, Jr., Hainesville, N.J.
 Mortgage Trust Co. of Pa., Philadelphia, Pa.
 Miss Mary Miller, 1230 Spruce St., Philadelphia, Pa.
 Henry D. Biddle, 311½ Walnut St., Philadelphia, Pa.

Dr. Calvin C. Halsey, Montrose, Pa.
 Rev. William Baldwin, Great Bend, Pa.
 Gen. William Lilly, Mauch Chunk, Pa.
 Second Nat. Bank, Mauch Chunk, Pa.
 Enos E. Thatcher, West Chester, Pa.
 Mrs. Townsend Poore, Scranton, Pa.
 Rev. Burdett Hart, D.D., New Haven, Conn.
 Dr. Frank H. Wheeler, New Haven, Conn.
 Charles R. Christy, Stamford, Conn.
 Mrs. Catharine P. Fuller, Woodmont, Conn.
 Miss Jessie Henderson, Lenox, Mass.
 Dr. M. J. Halloran, Worcester, Mass.
 Albert Walker, Bennington, Vt.

Address for Report and Monthly Bulletin

HENRY A. RILEY, General Eastern Manager, 191 Broadway, N.Y.

"The New Uncle Tom's Cabin."
 EDWARD BELLAMY'S
LOOKING BACKWARD.
 In Cloth, \$1.50. Paper, 50 Cents.

"Bellamy's wonderful book."—EDWARD EVERETT HALE.
 "It has made a deeper and more lasting impression than any other book of the year, not even excepting the two great theological novels."—Boston Herald.
 "The vital, inspiring, hopeful, convincing power of this book."—*Literary World*.
 "The extraordinary effect which Mr. Bellamy's romance has had with the public; * * * one cannot deny the charms of the author's art; * * * this alluring allegory."—W. D. HOWELLS.
 "Immensely attractive."—*Commercial Bulletin*.
 "That astonishing book, 'Looking Backward' ; how it haunts one like a grow-up; 'Alice in Wonderland.' The mind follows entranced."—*Boston Gazette*.
 "That remarkable and fascinating novel which so many are now reading."—E. C. STEEDMAN, in *The Critic*.
 "A very extraordinary work."—*Historical American*.
 "A romance of surpassing merit and noble purpose."—EDGAR FAWCETT.
 "It is a revelation and an evangel."—FRANCES E. WILLARD.
 "The book which thoughtful and serious-minded people are chiefly reading and discussing."—*Boston Herald*.
 "It is the 'Uncle Tom's Cabin' of the new era."—*The People*.
 "Bellamy's exceedingly clever book."—*New York Tribune*.

TICKNOR & CO., Boston.

KNABE

PIANOFORTES.

UNEQUALLED IN
 Tone, Touch, Workmanship and Durability.

WILLIAM KNABE & CO.
 NEW YORK: No. 112 Fifth Av., above 16th St.
 BALTIMORE: Nos. 22 and 24 E. Baltimore St.
 WASHINGTON: No. 817 Market Space, Penn. Av., near 9th St.

SCHOOLS AND COLLEGES
 will have a positive advantage by ordering their furniture apparatus and supplies from
 C. PARDO & CO.,
 31 East 17th St., New York.

Wants.

WANTED.—A teacher for the Natural Sciences and History, who is also competent for the position of Associate Principal, in a flourishing private school. Address P. O. Box 305, Plainfield, N.J.

ON SALARY AND COMMISSION A CANVASSER for Subscriptions to *Science*.

Old and Rare Books.

A. S. CLARK, Bookseller,
 34 PARK ROW, NEW YORK CITY.

A Gleaner in the By-ways of Literature. Results of Gleaning found in Catalogues issued from time to time.

CATALOGUE NO. 27 NOW READY.

BACK NUMBERS and complete sets of leading Magazines. *Rates low.* AM. MAG. EXCHANGE, Schoharie, N.Y.

H. WILLIAMS,
 Dealer in Old Magazines, Reviews, &c. Scientific periodicals a specialty. 39 Macdougal St., N.Y.

FOOD ADULTERATION

And its Detection. With photomicrographic plates and a bibliographic appendix. By J. P. Battershall, 248 pages, 8vo, cloth. Price, \$3.50. Circulars and Catalogues on application. E. & F. N. SPON,
 12 Cortlandt St., New York.

SCOTT'S EMULSION

OF PURE COD LIVER OIL AND HYPOPHOSPHITES

Almost as Palatable as Milk.

Containing the stimulating properties of the Hypophosphites combined with the Fattening and Strengthening qualities of Cod Liver Oil, the potency of both being largely increased,

**A Remedy for Consumption.
 For Wasting in Children.
 For Scrofulous Affections.
 For Anæmia and Debility.
 For Coughs, Colds & Throat Affections.**

In fact, ALL diseases where there is an inflammation of the Throat and Lungs, a WASTING OF THE FLESH, and a WANT OF NERVE POWER, nothing in the world equals this palatable Emulsion.

SOLD BY ALL DRUGGISTS.

SCIENCE

FRIDAY, FEBRUARY 15, 1889.

SOME EXAMPLES OF MEXICAN PRE-COLUMBIAN ART.

DURING the winter of 1881 I collected on the site of the ancient city of Teotihuacan ("the place of those who adore the gods"), about forty kilometres north-eastward from the City of Mexico, and within the great valley enclosing the capital, several hundred objects of moulded and modelled terra-cotta. Some of these I gathered from the heaps of *débris* that mark the locality of this "former religious centre of the Nahuan nations;" but the greater number were secured, generally six or eight in a place, by visits to the houses of the simple agricultural people, who had found them while cultivating the neighboring gardens and fields. The soil in which these objects had reposed for a period of unknown duration, is spread around the two great *teocalli* of earth and broken stone that rise conspicuously above a broad fertile plain. The Pyramid of the Sun, the principal of these prehistoric structures, is prob-

displayed in the great museums in Europe and on this continent to modern apprehension are generally meaningless or grotesque. Often two round cavities stand for eyes; a crooked ridge laboriously furrowed out with stone tools is offered for an arm; or the action of the figure is so violent and crudely expressed, or the surface so overloaded with symbolic designs, that the original thought is lost to the observer of to-day, or seems the work of some unskilled and ignorant devotee. It is, however, not in the hard stone carvings that we can hope to find any adequate evidence of the mental capacity of the aboriginal sculptor. The plastic clay that abounds was all that he could desire for fixing and transmitting his conceptions. Indeed, it seems to me that no form of pristine thought should advance more rapidly and steadily toward excellence than that which may be expressed in clay. The artistic conceptions of the best minds, once formulated in this material, would be transmitted to following generations in the shape most readily comprehended, imitated, and improved, — a model and a stimulus for every succeeding artist.



2



1



3

ably the highest work of American aboriginal peoples. It overtops the celebrated mound of Cholula nearly fifty feet, and, with a base somewhat larger than that of the chief pyramid of Gizah, it rises 214 feet, nearly half the height of the Egyptian world-wonder.

The rains of many summers have furrowed the sides of this ancient temple into irregular ravines, through the aid of which, and by exercising a little care in selecting a zigzag path, I was able to ride my tough pony to the platform upon the summit.

Among the numerous fragments of terra-cotta obtained as above described, a large proportion are one to two inches in either dimension, and represent the human head or face. Many are reliefs broken, by the action of time or otherwise, from vessels of clay, or from figures more or less complete. These faces or parts of figures are often accompanied by elaborate ornaments, such as necklaces of beads, high head-dresses of feathers, and large ear-rings, all carefully moulded or stamped in the clay. Many pieces consist simply of heads attached to a short neck, without any evidence of having formed part of a more complete figure. From all the evidence in my possession, I conclude these objects belong to a date anterior to the Spanish Conquest. By some students a portion of the types are referred to the Aztec period; another portion, to the Toltec, or even to the pre-Toltec Totonacs; but into this discussion I shall not here enter.¹

The massive Mexican statues of basalt and trachytic lava that are

Out from the dull uniformity of primitive thought from time to time glows the light of a genius whose inventions, transmitted by poetry or tradition or the plastic arts to succeeding enlightened peoples, command from them the warmest sympathy and recognition, — a genius who, like him of "the wooden statue of Sakâra," is hailed as a worthy compeer by cultivated men of the ripest civilization. The student wandering among the conventionalized art-products of the oldest dynasties at Boulaq, stands amazed before this wonderful production of a mind that wrought in the dim twilight of the history of the human race. Thereafter he feels that the possibility always exists of detecting among the works of any unenlightened people isolated examples of a high art insight. The tools of the Sakâra sculptor were of a primitive character, and he sought the soft native wood as a medium for his productions: with still ruder tools at his command, the Mexican artist found the proper medium in the potter's clay that lends itself, with all its perfections, alike to the hand of the mound-builder and to the modelling tools of Canova.

The accompanying engravings represent faces that were selected from those found at Teotihuacan to illustrate the capacity of pre-Columbian Mexican artists. They have been reproduced, without retouching, by the direct process, from my photographs of the originals in the Metropolitan Museum.

No. 1 represents a fragment of terra-cotta engraved about one-third greater than the actual size. It is a portion of a larger clay object, upon which the remarkable face has been impressed by means of a carefully prepared matrix or stamp. This matrix was

¹ For a learned and valuable contribution to our knowledge of the "terra-cotta heads of Teotihuacan," see Mrs. Zelia Nuttall's illustrated essays in the *American Journal of Archaeology*, 1886.

in all likelihood formed of burned clay, like hundreds that have come down from the primeval potters of Europe and America, and was itself made by an impression from an original carving of clay or other substance. The face shows slight evidences of retouching: perhaps the expressive wrinkles over the right eye were added after the figure was impressed by the matrix.

The surface of many ancient Mexican vases is loaded with ornament, such as stamped or modelled faces and heads of men and animals. This fragment may have formed such an ornament; and if the vase was designed to contain the ordinary intoxicating beverage of the Aztec peoples, — the fermented sap of the century-plant (the *Agave Americana*), — the expression of this face would be singularly appropriate, and the association recall the bacchanalian figures moulded by ancient Roman artisans upon their drinking-cups of Samian ware. Enormous quantities of this national drink — the modern pulque, the ancient *octli* — are still consumed, and special trains upon the railway convey it in hogsheds and goat-skins to the capital city from the district where this clay object was discovered.

The story the ancient artist has sought to tell by every lineament of the face is evidently one of habitual and excessive drunkenness. The swollen eyeballs, covered by thick lids; the inane unsymmetric forehead, with a curious forked wrinkle on its weak side; the hanging full and flabby cheeks; the lips, tumid and uncontrolled, enclosing a meaningless mouth, — in all these we have a consistent story of continued vinous excess. This consistency is worthy of especial attention: not a feature or line in all the face fails to give forth the same mute evidence of complete abandonment to the poison. Finally, the artist, with a stroke of genius worthy of Hogarth, has caught the very spirit of besotted helplessness by sinking the entire right side of the face out of symmetry, thus proving, that, while possessing no knowledge of our modern notions of nervous centres and facial paralysis, the pre-Columbian sculptor had developed the capacity to place upon the human face the physiological evidences of a mind and body lost in the last stages of alcoholism.

No. 2 is also a fragment of some larger object, perhaps a vase. It was moulded, as was the case in the former instance, upon a soft prepared surface of clay, by means of a matrix, but it shows no evidence of retouching. It is the face, in relief, of an individual less deeply sunk in bacchanalian indulgence; but the expression is that of a drunkard, and not that of a person in the repose of sleep or nerveless in the relaxation of death. The lips are slightly apart, and there is breath between them. The eyes are closed, but the face is under control, and its texture is firmer than in the preceding figure. It is a work of less merit than No. 1, but the artist has succeeded in delineating drunkenness in every feature, and has maintained throughout the typical stolid expression of the aboriginal American races.

No. 3 represents a face moulded upon the leg of a terra-cotta vase. This portion of the clay vessels of Southern and Central America has often been seized upon by the ancient potter as a basis for elaboration. Sometimes it is wrought to represent the head of an animal, as the crocodile or fish; while among prehistoric pottery from the Chiriqui cemeteries, northward from Panama, nearly every carefully made vase has hollow legs. A ball of clay rattles loosely in this open space, and, through a narrow aperture, may be seen moving when the vessel is shaken. The Mexican vase-legs are in some localities quite abundant, because, like the "crescent ears" of the pots of the prehistoric Italian *terramare*, their solidity preserves them where the less firm portions of the vessels have crumbled. The exigencies of the case have confined the artist of this *basso-relievo* to a triangular surface, narrowing downward nearly to a point, and he has admirably adapted his work to the predetermined shape. On the foot of what may have been an ancient pulque jar we see here represented still another and a far more cheerful phase of intoxication. The individual has reached a state of mental excitement where he is "o'er all the ills of life victorious." He "accepts the good the gods provide" with child-like joy and abandon. In the elation of the moment he half closes his eyes, but at the same time, unlike the preceding inebriates, he finds companionship in the outer world by shrewdly keeping it in view. There is no flabbiness in his cheeks and lips: the former are bunched in a jolly grimace; the latter, drawn thinly over

his big teeth, broaden into a grin as successful as the narrowing margin of the vase-leg will permit. In short, we have before us the work of an aboriginal artist, who tells us successfully the story of a jolly reveller, who might be about to sing to his companions the chorus of "Willie brew'd a peck o' maut."

By turning this clay visage at various angles, it is found that the most advantageous view of the features is that from above. A large vase containing a liquid would in simple aboriginal habitations naturally be placed where it would rest below the level of the eye. Can it be possible the ancient artist wrought the model from which this vase-leg was moulded, conscious he was addressing eyes that would look from above upon his completed work?

With evidence before us such as that here detailed of the comparatively advanced culture in one direction of the old Mexican peoples, and of the capacity of some of their artists to deal successfully with complex questions in designing and modelling figures expressing conditions of the human mind, does it not seem probable that upon our southern border a rich field and many surprises await the patient scientific investigator? — a field that is all the more important to the anthropologist, because embedded in it is the history of a culture that may be autochthonous; and that is of all the more moment to us, because this culture grew through many centuries, subject to the developing forces of an environment in some important elements similar to that which is to-day modifying us and converting us into "Americans."

ROBERT H. LAMBORN.

STREET-RAILWAY MEN VISIT AN ELECTRIC RAILWAY.

ON Tuesday, Feb. 5, there was a gathering at Boston, Mass., of street-railway men of New England, who had come from all quarters of the six New England States. The object of the gathering was to inspect the electric branch of the West End Road at Boston, installed by the Sprague Electric Railway and Motor Company of New York. The party was met by Messrs. Blake & Sawyer, and the start was soon made from the Park Square end of the line in a number of electric cars which President Whitney of the West End Road had provided for the purpose. The cars were quickly filled by the street-railway men, and the departure made from Park Square in short order out to Boylston Street. The first stop was made at the power-station of the road, situated at Allston, where the visitors disembarked, and were shown the generating-station for the electricity used in operating the cars. On entering the main room, and passing by the two high-speed Arming-ton & Sims engines of 200 horse-power each, — one, though running, being so noiseless in its action that its motion passed almost unnoticed, — the four dynamos, of 80,000 watts capacity each, engaged the attention of the party. From each dynamo there are three leads passing under the floor to the switch-board, where connection is made by separate conductors to the underground conduit and overhead system. This switch-board and each regulator have for their bases an insulating compound to which they are fastened, and each regulator-shaft carries a gear; so that, by means of a rack which meshes into all four gears, the four dynamos may be regulated by one operation. Still higher on the wall are the safety fusible strips mounted on slate. At the top of the switch-board are placed four improved lightning-arresters resting on insulated brackets. These arresters consist of a large electro-magnet, which may be short-circuited in fine weather by a switch. From the terminal connected with the outside line there is a circuit with an alternative path to the ground, with the use of the usual break, an electro-magnet. To a lightning-current passing over the line, the large electro-magnet acts like a choking coil, and offers a large resistance; and the current, taking the alternative path, jumps over the air-space, when the electro-magnet, operating, breaks the circuit, thus extinguishing the arc. The power-station is lighted by a large number of electrolights, under control in groups of five, at a switch-board at one end of the building. The boiler-house has three 150-horse-power steel tubular boilers, with Jarvis setting, feed-water heater, injector, steam-pump, etc. The back wall of the power-house is built with a view to its extension in the rear, so that the capacity at the station can be

doubled, the position of the chimney being in the centre of the future station. Adjoining the power-station a new car-house has been erected, with capacity for twenty-six cars. The cars, when in this house, rest on skeleton tracks, under which the inspectors can walk, and, by aid of incandescent lamps with flexible connections, can examine and inspect the machinery of each car. After the party had fully examined the workings of the power-station, and listened to the explanations of its operation from the engineer in charge, they reboarded the electric cars, and were carried quickly out Beacon Street and Harvard Avenue to the terminus of the road at Oak Square, Brighton. To a great many in the party this trip was the first ever made on an electric railway, and the exclamations of surprise and delight were universal. On the return trip the cars were speeded to ten or twelve miles an hour in places, and much praise was bestowed upon the easy starting, which was prompt though without jar, the complete control over the car, and the ease of the car in rounding curves and in speeding. Each of the cars was brilliantly lighted by five incandescent lights of 16 candle-power each,—three inside the car, and one on each platform. These lamps had the municipal cut-out; and, when one

about 3,500 pounds, is 6 feet in height, and occupies a space 8 feet long by 2½ feet wide.

For tensile strength, the machine will test specimens up to 18 inches in length, 1¼ inches square, 1⅜ inches in diameter if round, and 2⅝ by 1 inch if flat, allowing for a 25-per-cent elongation in the longest specimens, and more for those of shorter length. For transverse strains, it will test specimens from 6 to 20 inches in length; and for compression, specimens up to 8 inches long and surfaces up to 6 inches in diameter. The pulling head has a movement of 23 inches. The machine has four different speeds for tensile and transverse tests, and two for compression, as follows: transverse and tensile, 4 inches per minute, 1 inch per minute, 1 inch in 3½ minutes, and 1 inch in 10 minutes; compression or reversing, 4 inches per minute, and 1 inch in 3½ minutes.

Power is applied by levers and friction-pulleys for starting, stopping, and reversing; and for changing the speeds, a hand-wheel and tumbling ball are used. In compression tests, and in tests of material not ductile, when the pressure is run up rapidly, there is an arrangement of friction-gears, similar to those of a hoisting-engine, which gives an extremely slow and steady motion to the

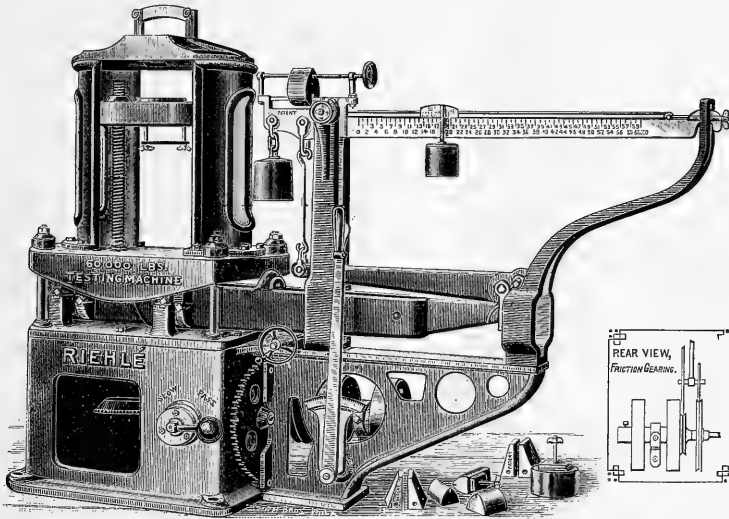

RIEHLÉ SCREW-POWER TESTING-MACHINE.

breaks, the increase of candle-power in the remainder calls the attention of the conductor, who inserts a new lamp. The visitors left Boston for their respective homes full of enthusiasm over the application of electricity to street-railways, and with a better knowledge of the advantages which electric power has for this purpose over any other power.

THE RIEHLÉ TESTING-MACHINE.

TESTING-MACHINES have become a necessary part of the equipment of all manufacturing establishments and constructive works, government and private, where the strength of materials must be accurately determined. Among the testing-machines now in use, those made by the firm of Riehle Brothers of Philadelphia stand prominent as examples of good workmanship, strength, accuracy, and convenience in use. The accompanying illustration shows one of these machines. It is a vertical screw-power machine for testing materials by tensile, transverse, and compression strains, and has a capacity of 60,000 pounds. Other machines made by the same firm range in capacity from 10,000 to 200,000 pounds. The levers on the machines of all capacities are adjusted to the United States Government standard.

The machine shown in the engraving is adapted for those whose requirements do not call for one of greater capacity. It weighs

screw, thus enabling the operator to make the test with ease and accuracy. The bearings are of hardened steel balls, which do away with much of the friction incident to this class of testing-machines.

THE FLEISCHMANN SYSTEM OF GARBAGE-DISPOSAL.

ONE of the systems of garbage-disposal which seems to be one of the best is that known as the Fleischmann, and is now in practical operation in Buffalo. In speaking of this system, the *Sanitary Inspector* says:—

“The Fleischmann system of garbage-extraction consists principally of two processes. The garbage, as it is hauled in, is shovelled through man-holes into driers below. There are two of these driers, each receiving at one charge 5,000 pounds of garbage. Each drier consists of a double-walled metallic cylinder, between the walls of which steam at a pressure of about eighty pounds is admitted. In the interior of each drier, a rake revolves, constantly stirring up the garbage. These rakes are composed of steam-pipes into which steam of the same pressure is admitted, but the steam is not admitted into the chamber which contains the garbage. The steam which arises by the drying of the garbage is drawn out of

the drier by means of a fan, so that a partial vacuum is constantly maintained in the drier; and this steam is carried into the lower part of a chamber, where, as it rises, it meets with a series of sprays or sheets of water which fall from overlapping shelves. In this way the steam which comes from the drier is condensed, and flows away as an inoffensive mill, having no more odor than the condensed water of an ordinary steam-radiator. In this process of drying, sixty per cent of the weight of the garbage is removed.

"The second stage of the operation consists in putting the dried garbage into an apparatus called an extractor, where the grease and oil which it contains is thoroughly removed by benzine used in an automatic way, so that it is used over and over again without loss. The present plant in Buffalo disposes of about 30,000 pounds of garbage daily. From this, about 1,800 pounds of grease is recovered; and the remainder of the dried and pulverized garbage, amounting to a daily average of about 12,000 pounds, is quite rich

SPRAGUE ELECTRIC ROADS AT READING AND WILMINGTON.

In this issue of our paper we present views of two recent electric roads, taken from photographs, — one in Pennsylvania, and the other in Delaware.

One of these represents one of the cars upon the Wilmington, Del., City Railway. This railway, which was installed by the Sprague Electric Railway and Motor Company of New York, has been in operation for about eight or nine months; and the president and the directors of this road have felt so very well pleased with its operation, that they have ordered an additional number of cars. The railroad is two miles long, using the regular Sprague overhead system of wiring, with small working conductor three-sixteenths of an inch in diameter, which, according to the Sprague system of electric railways, is the only wire suspended over the street.



SPRAGUE ELECTRIC ROAD AT WILMINGTON, DEL.

in ammonia, phosphates, and the other constituents which are valuable in fertilizers, and it is readily sold to the manufacturers of fertilizers. This dried product is screened, and what is removed is sorted out, and nearly all of it finds a market. The old rubber brings a good price; the rags are sold; the bones are valuable as a source of bone-meal; the waste tin, brass, and other fragments of metal, all readily sell; and only a small residuum, such as corn-cobs, pieces of crockery ware, etc., are used as filling. According to the showing of those who are peculiarly interested, and of the health authorities at Buffalo, a business of this kind pays a good percentage on investment, and an examination of the works must convince any person that a sanitary triumph has been achieved. Upon the first introduction of the garbage to this treatment, it is subjected to a temperature which of course immediately disinfects it, if any of it should be infectious; and from none of the processes through which the garbage is put is there the least odor which is suggestive of danger; and, though much benzine is used in the second stage of the treatment, no smell of it whatever is detected anywhere in the establishment during its use."

Our other view gives a representation of two electric cars on the East Reading and Black Bear Railway, passing each other upon a turnout. This road has recently been installed by the Sprague Electric Railway and Motor Company, and has been in operation only about two months. The road has been operating very successfully ever since its installation, and has been carrying a large number of passengers.

FOGS.

AT the anniversary meeting of the Royal Meteorological Society, held on the 16th of January, Dr. W. Marcet, president of the society, delivered an address on "Fogs," which he illustrated by a number of interesting lantern-slides. Fogs and clouds are one and the same thing. A cloud is a fog when entered into; and a fog seen from a distance, suspended in the air, becomes a cloud. After describing the various kinds of fog, — e.g., river, sea, Newfoundland, radiation, town, etc., fogs, — Dr. Marcet referred to London fogs. Dr. Tyndall has accounted for them by assuming each particle of

condensed vapor to be covered by coal-smoke. These fogs usually accompany a high barometer, and are frequently dry in their character.

It is a well-known fact that cold air on the tops of hills, being heavier than the air below, slides down the slopes; so that the lower parts of hillsides are actually colder than the plains at some distance from the hills. Now, London, in the Thames valley, is surrounded by hills, — to the north, Highgate, Hampstead, and Harrow; in a westerly direction, Putney and Wimbledon; and in a more southerly direction, Clapham and Sydenham. The air is colder on these hills than in London, with its millions of inhabitants, its coal-fires and factories: hence it is heavier, and will have a great tendency to slide down the hills towards the town and the river. Should the air in town be on the point of saturation, and the cold air from above saturated with vapor, it is obvious that the increased cold from above will produce a precipitation of moist-

working drawings made, but actual construction is required, and is made possible in extensive workshops, the equipment of which has cost over forty thousand dollars. In electricity, in addition to the instruments and appliances usually found in electrical laboratories, it possesses the most complete and accurately adjusted series of Sir William Thomson's electrical balances in this country; and there is a completely equipped testing-room for the purpose of calibrating and standardizing commercial instruments. Another important feature is the restriction placed upon the number of students admitted. The plan of the institute is to limit the attendance to such an extent as to realize the great benefits arising from small classes. Ample facilities will therefore be afforded to all who undertake its courses of study. Those who are contemplating preparation for either mechanical, civil, or electrical engineering, will do well to consult the catalogue of the Rose Polytechnic Institute.



TURNOUT ON THE SPRAGUE ELECTRIC ROAD AT READING, PENN.

ure, and it will come to pass that a fog is produced. If the hill-tops be not only colder than the air below, but enveloped in a fog, it stands to reason that the fog below will be all the denser, and especially in the neighborhood of water, such as the river Thames, and the ornamental waters in the parks.

THE ROSE POLYTECHNIC INSTITUTE.

THE Rose Polytechnic Institute is one of three or four schools in the United States which are especially devoted to the education of civil, mechanical, and electrical engineers. It owes its existence to the generosity of the late Chauncey Rose of Terre Haute, Ind., who bequeathed something more than half a million of dollars for its establishment and support. It is one of the youngest of the technological schools of the country, having been opened in the year 1883. One of the peculiar features of the institute is the thorough and extensive "shop-practice" of the students in mechanical engineering. Not only are machines designed, and

THE DERELICT AMERICAN SCHOONER "W. L. WHITE."

MR. EVERETT HAYDEN, meteorologist to the Hydrographic Office, has compiled the reports on the history of the derelict schooner "W. L. White," and the results of his investigation have been published on a supplement to the monthly "Pilot Chart," a portion of which is reproduced here. Besides showing the track of the "W. L. White," those of the derelict barks "Telemach" and "Vinuczo Perrotta" have been plotted on the map.

Mr. Hayden reports that a telegram dated Stornoway, Hebrides Islands, Scotland, Jan. 23, 1889, marks the termination of the remarkable cruise of this derelict vessel. Abandoned off Delaware Bay during the great blizzard, March 13, 1888, she has now completed her long and erratic transatlantic voyage, and lies stranded upon Hasker Island, one of the many little rocky islands of the Hebrides, in latitude 57° 42' north, longitude 7° 42' west. The track of this vessel, as plotted on the "Pilot Chart" from month to month during this long interval, has been of constantly increasing

interest, and a study of her track and the tracks of other derelicts plotted on the accompanying chart cannot fail to be valuable to every navigator of the North Atlantic, as illustrating the general course followed by these dangerous obstructions to navigation, and the irregularities to which this general course is subject. The fact may well be noted here that the tracks and latest reported positions of derelicts and wreckage on the high seas are shown on no other chart but the "Pilot Chart," and the danger to navigation caused by them is sufficiently indicated by the mere statement that the number recorded each month in the North Atlantic alone varies from twenty-five to as many as forty-five, every great ocean storm largely increasing the number. Therefore it is very desirable that masters of vessels should supply the Hydrographic Office with ex-

about by the varying winds, a constant menace to navigation along the greatest highway of ocean commerce in the world. During these six months alone she was reported by 36 vessels, three of which sighted her in a single day. In her cruise of ten months and ten days she traversed a distance of more than 5,000 miles, was reported 45 times, and how many more vessels passed dangerously near her at night and in thick weather it is impossible to even estimate.

The direction and force of the winds that helped to determine her track during this long voyage, as indicated by reports from hundreds of vessels in her vicinity at various times, were as follows: For a week after being abandoned, and in fact throughout March, with the exception of four days, she experienced north-westerly

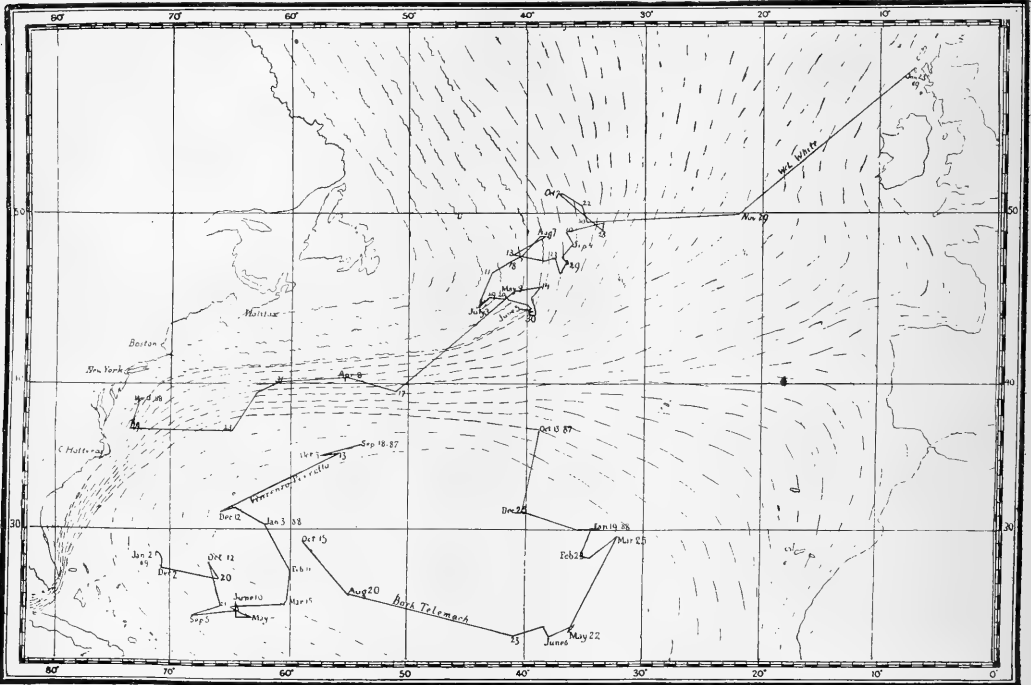

TRACK OF THE DERELICT SCHOONER "W. L. WHITE."

act detailed descriptions of all such derelicts sighted, in order to make it possible to identify them with others previously reported.

The following brief summary of the leading features in the cruise of the "White" will be found of interest: She was a three-masted schooner, belonging to Mr. A. F. Ames of Rockland, Me., lumber-laden, and after being abandoned started off to the southward under the influence of the inshore current and the north-west gale, with masts and portions of her sails standing, and ensign set with union down. Upon reaching the Gulf Stream, she turned away to the eastward, and commenced her long cruise toward Europe, directly in the track of the thousands of vessels engaged in transatlantic commerce, drifting blindly about at the mercy of wind and current. The most remarkable feature is the zigzag track she followed in mid-ocean, between latitude 44° and 51° north, longitude 33° and 44° west, from the beginning of May till the end of October. Previous to this time she followed a course about east-north-east at an average rate of about 32 miles a day, and subsequently she moved east and north-east 1,260 in 84 days, an average of 15 miles a day; but during this long interval of six months she remained within this comparatively small area, drifted back and forth by the Gulf Stream and the Labrador current, and tossed

winds of varying force. Westerly winds continued during the first nine days of April, followed by five days of variable. From April 15 to 18 she encountered a strong westerly gale, followed by southerly winds, which prevailed the remainder of the month. Throughout May the winds were very variable, never more than two days in succession from the same direction. Moderate northerly gales were experienced on the 6th and 20th, and a fresh gale from the south-east on the 23d. Variable breezes continued throughout June, with westerly gales on the 24th and 30th. July opened with a moderate gale from the west, followed by south-westerly winds for a fortnight, hauling to west and north-west. Similar weather prevailed during August, with the exception of moderate gales from the eastward on the 6th, and from the westward on the 16th, 17th, and 22d. Generally westerly winds prevailed from Sept. 1 to 19, and easterly during the remainder of the month. During November the winds were westerly throughout, including several strong gales. Variable breezes were encountered during the first half of December, but during the remainder of the month the prevalent directions from south to west, with strong westerly gales from the 19th to the 25th. South-westerly winds prevailed from Jan. 1 up to the time she went ashore on Hasker Island.

The history of this derelict furnishes the strongest possible proof of the importance of this subject to masters of vessels, as well as of the cordial support which they have given to the Hydrographic Office in its efforts to collect and publish early and accurate information by means of which this danger to navigation may be diminished. The various commercial nations should unite in the effort to keep the seas clear of such obstructions, and it is a subject that may well be discussed by the forthcoming International Maritime Conference.

HEALTH MATTERS.

TYPHOID STATISTICS.—Professor Ruata of Perugia is authority for the statement that there are annually in Italy nearly 300,000 cases of typhoid-fever, of which number 27,000 prove fatal. One-third of the persons in Italy who reach the age of forty-five have the fever, and in some districts more than three per cent of the population die from this one cause.

ARSENIC IN FABRICS.—The *London Chemical News* states that Mr. A. W. Stokes has examined a hundred samples of imitation Indian muslins and cretonnes, and found that twenty-three per cent contained arsenic in appreciable quantities, the highest proportion 2.1 grains of white arsenic per square yard. The colors in which arsenic was principally present were the terra-cotta reds and the greenish-browns. Of the wall-papers submitted to Mr. Stokes by various manufacturers, ten per cent were found to contain arsenic. Thirty other articles of household use, such as plushes, velvets, carpets, mats, silks, etc., were examined, and in only one sample — a little flax mat of green color — was arsenic found.

BACTERIA IN THE GLACIERS.—Dr. Schmelt of Christiania (*Centralblatt für Bacteriologie*) has found vast colonies of bacteria in the ice of the Jerstedalsbrå glacier and in the streams fed by it. They appear under the form of rods, and resemble the *Bacillus fluorescens liquefaciens*. During their period of growth these bacteria emit a fluorescent material. They multiply with great rapidity during periods of thaw.

A NEW DEODORANT.—Bromine has for a long time been recognized as being valuable in the treatment of gangrene and foul-smelling ulcers; but until recently its merits as an effectual and cheap deodorant have not been appreciated, according to the *New York Medical Journal*. It was brought into prominence a few months ago by Mr. Martin, the chemist of the health department of this city, who suggested its use upon the earth thrown up in laying the electric subways. As it is a by-product obtained in the manufacture of salt, and is not used extensively in the arts, it is sold at a very reasonable price, — about seventy cents per pound. It has the property of precipitating the hydrocarbons of illuminating-gas, and thus can be used to deodorize the earth exposed in excavations in the vicinity of gas-mains. More valuable than this is its effect upon decomposing organic bodies, which it renders completely inoffensive. This property renders it particularly valuable for use in stables, privy-vaults, urinals, cesspools, or in any place which may contain foul-smelling organic matters. It is soluble in about thirty-three parts of water; but a solution of this strength is not advisable, as there is a constant escape from it of the vapor of bromine, which is very irritating to the eyes and air-passages, and which may even attack wood and metals. For ordinary purposes it is used in solutions containing one part by weight to about eight hundred of water. In this strength it may be used freely without its affecting any thing which it may touch. A few gallons used daily will remove all ammoniacal odors from stables, or a few quarts will thoroughly deodorize the entire plumbing system of an ordinary house. It also might be used with advantage upon ordinary house-garbage, which usually becomes offensive so speedily in warm weather. There would appear to be scarcely any limit to its usefulness in this branch of sanitary science; and it will, as soon as its merits are better known, undoubtedly be adopted universally as a substitute for the deodorants now in use, which usually act by substituting one unpleasant odor for another. The only drawback in its use lies in the fact that the undiluted bromine is strongly corrosive; and, if it touches the skin, causes a painful

burn. Where it is used in large quantities, this can be obviated by opening the bottle, or, what is simpler, breaking it, under water. As its use becomes more extended, it will undoubtedly be put up in pearls or tubes containing only as much as would be needed at one time in the average household.

TRANSMISSION OF DIPHThERIA.—Dr. De la Roche believes that diphtheria can be transmitted from animals to man. He has had under his care two women suffering from diphtheria, which he thinks he has traced to the contamination of drinking-water from a cistern by the excrement of pigeons, which had been washed down by the rain from the roof on which these birds had perched. Admitting the possibility of the transmission of diphtheria in this manner, the means of combating it are simple. In places where spring-water and well-water are not available, or where the supply consists of rain-water collected in cisterns, it is well to limit pigeon-breeding, and to construct dove-cotes as far away as possible from dwelling-houses. As to the construction of cisterns, they should be built according to the rules of public hygiene laid down by Gania in his work entitled "Utilité des Cisternes."

MALARIA.—Dr. Henry B. Baker, the well-known sanitarian, contributed a paper, at the last meeting of the American Medical Association, on "Malaria, and the Causation of Periodic Fever." After an able discussion of the subject, he sums up as follows: "So far as evidence is yet presented, it seems to be proved, then, that (1) intermittent fever is proportional, directly or inversely, to the average daily range of atmospheric temperature; (2) the controlling cause of intermittent fever is exposure to insidious changes, or changes to which one is unaccustomed, in the atmospheric temperature; (3) in the mechanism of the causation of intermittent fever, the chief factor is the delay in the re-action from exposure to cool air (this delay, extending to a time when greater heat-loss should occur, results in the abnormal accumulation of heat in the interior of the body, and in disturbed nervous action, — the chill), and the final re-action is excessive because of the accumulation of heat, and sometimes because it occurs at the warmest part of the day; (4) the fever is the excessive re-action from the insidious influence of the exposure to cool air, and it is periodical because of the periodicity of nervous action, and because the exposure and the consequent chill are periodical, owing to the nightly absence of the warmth from the sun; (5) residence in valleys, or on low lands through which or upon which cold air flows at night, and thus causes insidious changes in the atmospheric temperature, favors intermittent fever; (6) in our climate, those measures, such as drainage, which enable the soil to retain warmth during the night, and thus reduce the daily range of temperature immediately over such soil, tend to decrease intermittent fever among residents thereon; (7) in the cure and prophylaxis of intermittent fever, those remedies are useful which lessen torpidity, and tend to increase the power of the body to re-act promptly to insidious changes in atmospheric temperature; (8) the slowness of the pulse, and other indications of torpidity, associated with retention of bile or with certain disturbances of the functions of the liver, are well known; but, so far as known to the writer, these conditions have not heretofore been considered as causative of the fever in the manner herein suggested.

SCIENTIFIC NEWS IN WASHINGTON.

Rock-Gas and Related Bitumens. — A Diagram of the World's War-Vessels. — The Eastern Cherokees. — Some Habits of Koreans.

Rock-Gas and Related Bitumens.

IN a communication (the second on the list) presented before the Philosophical Society on Feb. 2, Mr. W. J. McGee pointed out, that, *pari passu* with the industrial development accompanying the utilization of rock-gas, geologic science has made an unparalleled stride within a few months. When exploitation for gas began in Ohio in 1886, the geologist found himself utterly unable either to guide the efforts of the prospector or to predict the results of his work; yet within the ensuing two years the laws governing the accumulation and distribution of gas and oil have been so fully developed that the rock-gas problem to day claims a solution as satisfactory as

that of the well-known artesian-water problem, and the geologist predicts the success or failure of a prospect bore for gas or oil about as readily and reliably as he predicts artesian water or coal. The solution of the problem of rock-gas and petroleum marks an era in science no less than in industry. Mr. McGee discussed also the origin and distribution of gas, petroleum, and allied bitumens, showing that they are distributed throughout the various countries and geologic formations of the globe; that, other things equal, they are most abundant in the newer formations; that, other things equal, they are lighter in newer than in older formations; that the commercially available supplies of oil and gas are accumulated in natural reservoirs formed by flexures of the rocky strata into domes and anticlinals; and that in the American fields, at least, rock-gas, petroleum, and the heavier bitumens are simple products of natural processes of decomposition of the organic matter contained in sediments, their weight and other attributes depending upon the conditions under which decomposition took place. In conclusion, he pointed out that at the present rate of consumption the coal-fields of the earth will be exhausted within a few centuries, when it will become necessary to utilize, more completely than has yet been done, the much more abundant supplies of carbon compounds disseminated throughout the rocks of the earth in the form of bitumen. Rock-gas and related bitumens are indeed destined to form the fuels and illuminants of the future.

A Diagram of the World's War-Vessels.

Lieut. R. P. Rodgers, chief of the intelligence bureau of the Navy Department, has arranged in his room a curious and important map. It is a large map of the world on Mercator's projection, and on its surface are pinned colored tags showing the present position of all the war-vessels of the world. British vessels are represented by red tags, French by light blue, German by purple, American by dark blue, etc., and the positions of them are daily re-adjusted so as to conform to the latest advices. By this pictorial arrangement the secretary can in a moment sweep the seas, and ascertain exactly the whereabouts and strength of the naval power of the world.

Of the ships indicated in commission on the map, about one hundred and fifty belong to Great Britain and one hundred to France, while Germany and the United States have not more than forty each. Italian ships are mostly in the Mediterranean; Spanish ships, chiefly in the West Indies and at home. Germany has three warships at Samoa; the United States has one, and two more on the way, in the aggregate superior to the German contingent. China has a dozen or twenty ships, all on her own coast. She is not aggressive. In Central America we are outnumbered in a way to suggest that the Monroe doctrine is not to be enforced at once. We have at the Isthmus of Darien one pretty poor ship on the east side, none on the west side. France has one on each side, and Great Britain has three on each side. We have four vessels on the West African coast, and half a dozen in the seas of the Orient.

The Eastern Cherokees.

Mr. James Mooney of the Bureau of Ethnology, who has been for several years studying the Cherokees, is making some interesting reports of their condition and customs. It may not be generally known, he says, that the Cherokees, whose expulsion from Georgia and the contiguous States in 1838 was one of the most flagrant violations of treaty rights ever perpetrated by the United States Government, have not entirely abandoned their ancient country. On the contrary, a portion of the tribe, officially known as the "Eastern Band of Cherokees," still keeps up an organization in North Carolina, with its council, chiefs, and medicine-men, and numbers in all about two thousand souls, of whom about fifteen hundred are mainly full-bloods, speaking only their native language, while the remainder are more white than Indian. In addition to these, the official roster includes several hundred others who claim Cherokee rights, — to wit, a share in the tribal lands and educational privileges, — but the keenest observer could not distinguish them from any other white men; and their Indian blood, which in many cases is an extremely doubtful quantity, and denied by the Cherokees themselves, is about as dilute as that of the modern descendants of Pocahontas. Excluding these pseudo claimants, it will thus be seen, by reference to the report of the Indian commissioner, that

we still have in North Carolina a body of Indians about as numerous as the Arapahoes or Winnebagoes in the West, and far outnumbering such noted tribes as the Pawnees, Omahas, Osages, Comanches, and Nez Percés.

These Cherokees are chiefly in Swain, Jackson, and Graham Counties, and own altogether eighty-eight thousand acres. The reservation proper lies principally in Swain County, and contains one hundred and fourteen square miles, occupied by about twelve hundred souls, very few of whom can speak English. Their principal settlement is Elawāti ("paint clay"), known to the whites as Yellow Hill or Cherokee. Here are the council-house, the chief's residence, and the government training-school, containing nearly a hundred children under the efficient instruction of teachers appointed by the Quakers, under a contract with the government. There are five other day-schools supported by the interest on their *pro rata* share of the fund appropriated for the removal of the Cherokees in 1836. Aside from this, the band receives no aid from the government, the Supreme Court having decided that they are not entitled to participate in the benefits arising from any former treaties with the Cherokees, so long as they refuse to join the body of the tribe in the Indian Territory, — a proposition to which they are bitterly opposed. Their legal status is a peculiar one. Although living on a reservation, under care of an agent, and holding their lands in common, they are treated rather as intractable children, and deprived of the privileges accorded the rest of the tribe; while, on the other hand, they have the rights of citizenship, and vote at all local and general elections. In politics they are Republicans almost to a man, as they consider the success of their schools due to that party.

These Cherokees are the descendants of the few individuals who were allowed to remain under the treaty of removal in 1835, and of the larger number who fled to the mountains, and thus eluded the soldiers who were sent out under Gen. Scott to collect the Indians for removal to the West. Many of the older ones still remember with bitterness the events of this period. These Indians may fairly be called warriors, as three hundred of them served in the Confederate army during the late war, while quite a number also fought on the Union side. The former were a part of the Thomas Legion, occupied chiefly in East Tennessee. They are now quiet, law-abiding citizens, cultivating their small farms, and gathering chestnuts and ginseng in the mountains, to trade for cloth and coffee at the neighboring villages. A few are fairly prosperous, but the majority are in a condition of abject poverty. Isolated in the heart of the mountains, neglected by the general government, and deprived even of schools until within a few years ago, they are fully two-generations behind their more fortunate brethren in the West, and still keep up their old dances, ball plays, and conjuring practices, although many of them are professing Christians. Their present chief, N. J. Smith, known to his tribe as Tsalatibi, is an honorable and intelligent gentleman, of three-fourths Cherokee blood, speaking both languages fluently, and thoroughly devoted to the interests of his people. Through his efforts and the influence of the schools, the old Indian life is gradually giving place to the newer civilization.

Some Habits of Koreans.

On Saturday afternoon, Feb. 2, Mrs. E. R. Scidmore read a paper on the home-life of the Koreans, among whom she visited in 1887 as a guest of Judge Denny, the foreign adviser to the king. She said the Koreans are in most things poor copies of the Chinese. Their dress is the same as that worn by the Chinese before the Manchu conquest, which made the pigtail obligatory as a sign of submission. Wisps of straw and bits of cloth, says Mrs. Scidmore, hang at the doorways to delude the Devil and keep off evil spirits; and these are the only signs of worship seen about Seoul. They have the worship of ancestors, as the Chinese; and a trace of the old dragon-worship must order their toleration of snakes, as it is impossible to get a Korean servant to kill the snakes that drop from the mud roof and slip out of the flues of the kaugs that warm the floors of the houses.

Until the arrival of the American physicians, the king and queen had an army of necromancers and wizards in attendance upon them, and a form of shamanism was practised upon the sick. They were consulted as well in matters of state policy.

The strict seclusion of the women is relaxed on one day in June, when women may go anywhere with uncovered faces. The homes of the foreign residents in Seoul are visited then by thousands of curious women.

If a man walks over all the foot-bridges of the city on the middle day of January, he is supposed to secure good health for the year.

The city gates are closed and locked from dark until dawn, and it is death to the guardsman who opens them to admit any one. Generations of belated and wall-scaling Koreans have worn a staircase of crevices in the wall by which they mount to the gate tower; or the guardsmen will haul them up by a rope, there being a regular tariff of charges for the use of ropes, and the mandarins getting their regular percentage of the fees.

The manufactures of to-day are very crude and wholly inartistic. Peddlers of tin bring pieces of iron damascened with silver, that at once prove the Persian influence of the old arts by the decorative forms. Korean ambassadors are supposed to have met the Persians at the Peking Court in the time of Gingshis and Khublai Khan.

ETHNOLOGY.

Mound-Builders and Indians.

IN a recent number of the *Ohio Archeological and Historical Quarterly*, Mr. Gerard Fowke attempts to disprove "popular errors in regard to mound-builders." The author shares the view of Professor Cyrus Thomas, that the mound-builders were Indians, and that no great antiquity must be claimed for their works. The principal points adduced by the supporters of the theory of the existence of an ancient high state of culture and of a dense population are taken up one by one and discussed. Thus he reduces the opinion regarding the high character of the works of the mound-builders to its proper level. One of the important points to be decided, in an estimate of this ancient race, is the question regarding the density of population. The same reasons which were claimed for an ancient dense habitation of Arctic America have been considered as proof in the case of the mound-builders. It is said that numerous ruins on a limited area indicate a great number of inhabitants; but, as no proof can be given that they have been inhabited simultaneously, it is quite possible, that, notwithstanding their great number, the population was very sparse. It seems to us that the author's doubts as to a considerable antiquity of some of these ancient monuments are not well founded; but his criticism of the exaggerated views regarding the works and civilization of this ancient race is timely, and will help to the formation of a juster appreciation of the real significance of these works.

THE JADE QUESTION.—F. W. Clarke and G. P. Merrill have made an examination of a series of jade implements from the collections of the United States National Museum. The results of this investigation, which were published in the "Proceedings of the United States National Museum," are in favor of the theory that the occurrence of implements made of similar varieties of jadeites and nephrites in widely separated countries must not be considered proof of a common source of the material. The authors, whose arguments are based on very exhaustive microscopical and chemical investigations, believe that it is hardly practicable to distinguish, by means of thin sections and the microscope, between nephrites from various sources. "The presence or absence of enclosures of diopside, magnetite, or ferruginous oxides; the condition of these oxides, whether as ferric or ferrous; the varying tufted, bent, confused fibrous and even granular condition of the constituent parts,—are all, together with the color-variations and other structural peculiarities, matters of too slight import to be of weight from a petrographic standpoint. If, as seems possible, the majority of the nephrites are of secondary origin, why may we not expect to find all, or at least a great variety, of the structures described in the same or closely adjacent rock-masses? Chemical analyses on samples from near-lying, or even the same, localities are found often to vary as greatly as those from localities widely separated. Why may we not expect the same structural variations, when once they are carefully looked for? To our own minds, sufficient assurances that the widely scattered jadeite and nephrite objects were derived from many independent sources, and possess no value whatever in the work of tracing the migration and inter-communi-

cation of races, lie in the fact that these substances are comparatively common constituents of metamorphic rocks, and hence liable to be found anywhere where these rocks occur. Their presence is as meaningless as would be the finding of a piece of graphite. The natives required a hard, tough substance capable of receiving and retaining a sharp edge and polish, and took it wherever it was to be found."

SIGNALLING AMONG PRIMITIVE PEOPLES.—As is well known, the Indians of our continent use rising smoke to give signals to distant friends. A small fire is started, and, as soon as it burns fairly well, grass and leaves are heaped on top of it. Thus a large column of steam and smoke rises. By covering the fire with a blanket, the rising of the smoke is interrupted at regular intervals, and the successive clouds are used for conveying messages. Recently R. Andree has compiled notes on the use of signals by primitive people, and finds that they are well-nigh in universal use. Recently attention has been called to the elaborate system of drum signals used by the Kamerun negroes, by means of which long messages are sent from village to village. While it was supposed that this remarkable system of communication was confined to a limited region, explorations in the Kongo basin have shown that it prevails throughout Central Africa. The Bakuba use large wooden drums, on which different tones are produced by two drum-sticks. Sometimes the natives "converse" in this way for hours; and from the energy displayed by the drummers, and the rapidity of the successive blows, it seemed that the conversation was very animated. The Galla south of Abyssinia have drums stationed at certain points of the roads leading to neighboring states. Special watchmen are appointed who have to beat the drum on the approach of enemies. Cecchi, who observed this custom, designates it as a "system of telegraphs." The same use of drums is found in New Guinea. From the rhythm and rapidity of the blows, the natives know at once whether an attack, a death, or a festival is announced. The same tribes use columns of smoke or (at night) fires to convey messages to distant friends. The latter are also used in Australia. Columns of smoke of different forms are used for signals by the inhabitants of Cape York and the neighboring island. In Victoria hollow trees are filled with fresh leaves, which are lighted. The signals thus made are understood by their friends. In eastern Australia the movements of a traveller were made known by columns of smoke, and so was the discovery of a whale in Portland Bay. These notes, which might be increased considerably, show the general existence of methods of communication over long distances,—the art of telegraphing in its first stages of development.

NOTES AND NEWS.

RECENTLY much light has been thrown upon the phenomena of glaciation in Greenland. Dr. F. Nansen's daring trip across the inland ice will clear up important questions regarding the meteorological conditions of the interior and the maximum height of land. In the past year Mr. Ch. Rabot has examined the ice phenomena of the west coast, and arrived at the conclusion that the glaciers of Lapland must be considered inland ice in miniature. He is of the opinion that the latter must be considered vestiges of the glacial period in Scandinavia, which have remained to the present day in consequence of particular circumstances. He also observed that the great glacier of Jacobstown has advanced almost two miles since the year 1878.

—Mrs. Amélie Rives-Chanler has offered a prize of \$100 for the best American essay on child-labor. The money has been placed in the hands of Professor Richard T. Ely of Baltimore, secretary of the American Economic Association. The essay must not exceed 55,000 words, and must be in Professor Ely's hands not later than Dec. 2, 1889.

—The Royal Society of Palermo has decorated Professor P. T. Austen of Rutgers College with a gold order, in recognition of his scientific work.

—The following meetings will be held in Paris in August, 1889: viz., Congress of Geography and Ethnology, from Aug. 5 to Aug. 12; Association Française, Aug. 8 to Aug. 15; Congrès d'Anthropologie, Aug. 19 to Aug. 26.

SCIENCE:

A WEEKLY NEWSPAPER OF ALL THE ARTS AND SCIENCES.

PUBLISHED BY

N. D. C. HODGES,

47 LAFAYETTE PLACE, NEW YORK.

[Entered at New York Post-Office as second-class mail-matter.]

SUBSCRIPTIONS.—United States and Canada.....	\$3.50 a year.
Great Britain and Europe.....	4.50 a year.
Science Club-rates for the United States and Canada (in one remittance):	
1 subscription 1 year.....	\$ 3.50
2 " " 1 year.....	6 00
3 " " 1 year.....	8.00
4 " " 1 year.....	10.00

Communications will be welcomed from any quarter. Rejected manuscripts will be returned to the authors only when the requisite amount of postage accompanies the manuscript. Whatever is intended for insertion must be authenticated by the name and address of the writer; not necessarily for publication, but as a guaranty of good faith. We do not hold ourselves responsible for any view or opinions expressed in the communications of our correspondents.

VOL. XIII. NEW YORK, FEB. 15, 1889. No. 315.

CONTENTS:

SOME EXAMPLES OF MEXICAN PRE-COLUMBIAN ART.....	121
<i>Robert H. Lamborn</i> 113	
STREET-RAILWAY MEN VISIT AN ELECTRIC RAILWAY.....	114
THE RIEDEL TESTING-MACHINE.....	115
THE FLEISCHMANN SYSTEM OF GARBAGE-DISPOSAL.....	115
SPRAGUE ELECTRIC ROADS AT READING AND WILMINGTON.....	116
FOGS.....	116
THE ROSE POLYTECHNIC INSTITUTE.....	117
THE DERELICT AMERICAN SCHOONER "W. L. WHITE".....	117
HEALTH MATTERS.....	
Typhoid Statistics.....	119
Arsenic in Fabrics.....	119
Bacteria in the Glaciers.....	119
A New Deodorant.....	119
Transmission of Diphtheria.....	119
Malaria.....	119
SCIENTIFIC NEWS IN WASHINGTON.....	
Rock-Gas and Related Bitumens.....	119
A Diagram of the World's War-Vessels.....	120
The Eastern Cherokees.....	120
Some Habits of Koreans.....	120
ETHNOLOGY.....	
Mound-Builders and Indians.....	121
The Jade Question.....	121
Signalling among Primitive Peoples.....	121
NOTES AND NEWS.....	121
EDITORIAL.....	122
The Charter for the Nicaragua Canal.—Progress of Reform in New York Schools.....	
THE STANLEY EXPEDITION.....	123
THE TOPOGRAPHICAL SURVEY OF RHODE ISLAND.....	123
THE GREAT STORM OF MARCH, 1888.....	124
BOOK-REVIEWS.....	
Allen and Greenough's Latin Grammar.....	124
A Text-Book of General Astronomy.....	125
The Australian Ballot System.....	125
Recent German Studies in Hypnotism.....	125
The English Restoration and Louis XIV.....	127
Master Virgil.....	127
AMONG THE PUBLISHERS.....	127
LETTERS TO THE EDITOR.....	
Tornadoes: Fact vs Fiction.....	
<i>H. A. Hazen</i> 130	
A Deadly Gas-Spring in the Yellowstone Park.....	<i>Walter H. Weed</i> 132
A New Method for the Microscopical Examination of Water.....	<i>A. L. Kean</i> 132
Triple Births in the Human Race.....	<i>A. Graham Bell</i> 132

THE CHARTER of the Maritime Canal Company of Nicaragua has at last been granted by Congress. The plans for this great enterprise have been laid out so carefully, and the difficulties and advantages of the various routes have been considered so conscientiously, that the attempts at obstructing the passage of the bill were in no way justified. The feeling of the House on this subject was well expressed by the applause with which the passage of this important bill was greeted. The resistance offered on the alleged ground that the United States might be obliged to take up the work of the company was the more absurd, as the concession by the State of Nicaragua expressly states that no government except those of Central American States is allowed to hold shares in the company, and that the concession cannot be ceded to the government of any nation. The work will certainly be pushed with as much vigor as the surveys have been carried on, and we do not doubt that the canal will be completed in a very few years. The company has fulfilled the requirements of its concession by the State of Nicaragua, referring to the commencement and completion of the final surveys, and for the organization of an executive company; and the work of construction will also be begun in due time. While the prospects of the construction of the Nicaragua Canal are hopeful in every respect, the formation of the new Panama Canal Company has proved a failure. It will largely depend upon political

events in France, whether the work can be carried on or not; but recent events have proved that the confidence of private capital in M. de Lesseps' enterprise is not sufficient to enable him to carry on the enormous work that has to be accomplished towards the completion of his lock canal. It remains to be seen whether the government of France will be able to withstand the pressure exerted upon it in taking up the work. The long delays and evident difficulty of the route cannot but be of advantage to the Nicaragua Company, which will be able to absorb a large proportion of the working force kept idle at Panama.

THE CAUSE OF PROGRESS AND REFORM in New York City schools received a great impetus last Wednesday, when the Public Education Society submitted, through its committee, a memorial to the Board of Education on the state of the schools. This memorial was received and referred without comment to the committee on reform, to whose own report we have recently made reference in these columns. The memorial opens with the statement that the Public Education Society believes the New York City schools, as at present organized and conducted, to be deficient in respect to accommodations provided, in respect to courses and methods of instruction, and in respect to administration. In support of its belief, the society submits a number of facts. From the perusal of these, we learn that during the past year there were 150,312 pupils registered in all the schools. Of this number, 55,018 were registered in the grammar schools, and 95,294 in the primary schools. For the grammar schools there were provided 1,575 teachers, and for the primary schools 1,741 teachers. From this the society goes on to show, that, although the conditions in the grammar departments are bad enough, those in the primary schools and departments are infinitely worse. The primary schools or departments are invariably placed on the lowest floor of the school-building, where there is the least light, the greatest amount of dampness, and the greatest amount of exposure to foul and unpleasant or unhealthy surroundings. It seems that in the lowest primary grade the classes average in size 87 pupils to every teacher. This fact is in itself astounding, and a sufficient indictment of the entire system. It must be borne in mind that these children are the youngest and most impressionable in the schools, and that many of them are not six years of age. In the next lowest primary grade the classes average 58 pupils to the teacher; and in the grade above that, 56 pupils to the teacher.

It is then shown, that although the regulations of the Board of Education call for very meagre allowances of floor space and cubic air space per pupil, yet the law is violated in hundreds of instances. A list of 185 school-rooms is given in which members of the society, by actual inspection, have found the law to be violated to an alarming extent. For instance: school-rooms meant to hold 52 pupils are found to have 75 in average attendance, and one room which was meant to hold only 44 had 73 little children crowded into it daily. In spite of this overcrowding, 3,873 pupils were denied admission to the schools during the first week in September, 1888. The lack of play-grounds is adverted to, and an admirable suggestion made that the authorities should follow the example of London, and place the play-grounds on the roofs of the school-buildings in cases where the value of real estate does not permit the purchase of ground adjoining the school-houses. In illustrating the deficiency of the courses and methods of instruction, the memorial is very forcible. It shows, that, while the school-children in New York City are hard-worked and the curriculum overcrowded, the progress is not nearly so great as it is in the elementary schools of a number of European countries. It is chargeable, too, against the New York City system, that the course of study is arranged for the sole benefit of those who pursue it throughout, whereas not less than 60,000 children annually leave the public schools before they reach the age of twelve years. These children have had no

thorough or complete training in any one subject, they have merely made a certain amount of progress in a variety of branches; and in a large majority of cases this incomplete and disjointed instruction is all the education that these children will ever receive. The memorial protests against thus subordinating the primary-school course to the grammar-school course and that which succeeds it. The methods of examination and marking are unhesitatingly condemned, and ample evidence is quoted to sustain the charges.

The awkward and incongruous nature of school-administration seems to be very apparent. The Board of Education, the school inspectors, the school trustees, and the assistant superintendents have various and conflicting duties. It seems impossible to reach any sound basis for progress until these methods of administration are simplified and their efficiency increased. Then the improvements necessary in the course of study may naturally follow. The Public Education Society recognizes this fact, and therefore closes the memorial with the suggestion that a special commission, which shall include some members of recognized reputation and authority in matters of education, be appointed to investigate the conditions as they now exist in New York City, and to codify and simplify the school law. We earnestly hope that this proposition of the society will meet the approval of the Board of Education, and that the necessary steps will be taken to carry it into effect. The committee on reform, to which the memorial was referred, is certainly in sympathy with the Public Education Society. It now remains to so press this subject upon the attention of the majority of the Board of Education that the recommendations of the memorial will be adopted.

THE STANLEY EXPEDITION.

THE *Mouvement géographique* prints the various letters which have reached Brussels from Stanley Falls, and it is only now possible to understand somewhat clearly the course of Stanley's expedition. It will be remembered that Stanley sent a letter to Tippo-Tip. About the end of last year Lieut. Alfred Baert, secretary of Tippo-Tip at Stanley Falls Station, was obliged, on account of severe illness, to leave his post. His reports supplement Stanley's letter.

Stanley says that the route from Yambuya on the Aruvimi to Emin's province is excellent, and that provisions can be readily obtained. He does not say how long it took to accomplish the distance from Yambuya to Lake Albert Nyanza, but he states that the way back was accomplished in less than three months.

On the Albert Nyanza he met Emin, who, according to his last letters, was expecting to meet him there. The telegram of Dec. 23 stated that Stanley had left Emin near the Victoria. This fact appeared surprising, as it implied that Emin had left his province. This report appears to be due to a misunderstanding, Stanley saying in his letter that he had left Emin on the Nyanza, referring evidently to the Albert Nyanza, not to the Victoria Nyanza. After having organized a caravan of one hundred and thirty Wangnana, sixty-six men lent by Emin, and three soldiers, Stanley and his four white companions—Nelson, Stairs, Parke, and Monterey Jephson—left Emin on May 27, and returned to Yambuya by the way they had come, in order to look after the rear guard left there in charge of Major Barttelot, who was accompanied by Jamieson, Bonny, Rose Troup, and Ward. On Aug. 17, Stanley, who commanded the vanguard, arrived at Banalya. This place, which has so much puzzled geographers, is situated in Urenia, and is the same place at which Bonny, the commander of the vanguard of Barttelot, encamped on the bank of the Aruvimi. It is situated about fourteen days above Yambuya, and seven or eight days north-east of Stanley Falls. At Banalya, Barttelot was murdered by one of his men about a month before Stanley's arrival. When Stanley arrived, Bonny was still encamped there with part of the men furnished to Barttelot by Tippo-Tip.

On the following day Stanley wrote to the commissioner at Stanley Falls that he intended to stay there for ten days, and asked him to accompany him to Wadelai. Tippo-Tip declined this offer;

and Stanley, after having sent another letter to Stanley Falls, started on his way back to the Albert Nyanza.

Mr. A. J. Wauters, the editor of the *Mouvement géographique*, adds, "It will undoubtedly be found remarkable that Stanley, after an absence of more than a year in the fastnesses of Central Africa, without any news from Europe since May, 1887, did not push on to the Falls Station, where he was sure to meet Europeans and to find news. But he undoubtedly wished to avoid being asked questions regarding his discoveries, and regarding Emin and his projects, and therefore he left Banalya as rapidly as possible."

He re-enforced his caravan by one hundred carriers of Barttelot, his caravan now numbering two hundred and ninety-six men: Mr. Bonny, the only white man of Barttelot's rear guard, still on the Aruvimi, joined the expedition, which started eastward in the beginning of September. If he returned as rapidly as he came from the Albert Nyanza, he must have arrived there about the end of November.

These reports show that Osman Digma's letter, pretending that the Mahdi had captured a European at Lado on Oct. 10, cannot refer to Stanley or to Dr. Parke. They also dispose of the theory that the "white pacha" who was reported from the Bahr-el-Gazal region was Stanley; and Lieut. van Gele's hypothesis that these rumors referred to his expedition up the Obangi gains some probability.

Stanley's correspondence addressed to Europe reached Stanley Falls on Sept. 14. As Lieut. Baert left the station by canoe, he did not take these important documents along, which were kept back by Lieut. Haneuse. Lieut. Baert arrived at Bangala early in November, where he met the steamer "Stanley," which conveyed a number of men to the Aruvimi, where a station of the Belgian Company was founded at that time. He reached Leopoldville on board this steamer on Nov. 30. Stanley's letters are expected in Europe about a month or two hence.

THE TOPOGRAPHICAL SURVEY OF RHODE ISLAND.

THE endeavors of the Providence Franklin Society to arouse interest in a topographical survey of the State of Rhode Island have found a ready response in the Legislature of that State, and we learn with great satisfaction that the field-work for a map of Rhode Island has been completed. The work has been carried out by the United States Geological Survey on a plan similar to that of Massachusetts, the State and the United States Geological Survey sharing the expense equally. The State of Rhode Island falls upon fifteen different sheets of the great "Atlas of the United States," only five of which are wholly within the State. The total cost of the work to the State of Rhode Island will be five thousand dollars. The commissioners, David W. Hoyt, John W. Ellis, and Winslow Upton, to whose endeavors we owe the taking-up of this important work, conclude their report with some important considerations and suggestions. "The State," so they say, "will obtain a map similar to that which was contemplated in the plan of 1876, on a somewhat smaller scale, at one-quarter the estimated expense to the State. While this topographical survey is complete in itself, for all that it professes to do, it does not undertake to determine the boundary-lines of towns. This has been done in Massachusetts, as supplemental to the topographical survey, under an additional appropriation. Neither does this survey undertake to erect exact and permanent bench-marks from which levels may be reckoned.

"The commissioners desire to call the attention of the General Assembly to the fact that no provision has been made, either by the United States or by this State, for the publication and distribution of this map. To be of service, some arrangement should be made whereby it can be supplied, at a moderate expense, to the citizens of the State, as soon as practicable after all the plates have been received.

"In the atlas published by New Jersey, whose survey has been completed in co-operation with the United States Geological Survey, seventeen sheets are made to cover the entire State. The sheets overlap each other to some extent, and are so arranged as to be of the greatest value for local purposes. Each sheet includes more than three times the surface of a sheet of the United States Ge-

ological Survey, but is constructed on the same scale. These maps are sold at the cost of paper and printing. A somewhat similar plan, requiring five to eight sheets, might perhaps be adopted with advantage in this State. Each city, town, and village should, so far as possible, be found entire upon some one sheet; but to secure this, the original plates must be combined and re-arranged, and adjoining sheets must be made to include the same territory to some extent.

"It is desirable that a wall-map of the whole State should be published, in addition to the atlas form just mentioned. A map about $3\frac{1}{2}$ feet by 5 feet in size would include the whole State, with Block Island in its true position. This could be easily arranged, provided the State authorize some arrangement for such publication."

The three States of Massachusetts, Rhode Island, and New Jersey have thus been the first to secure, by a wise co-operation with the United States Geological Survey, good topographical maps of their whole territories. It is one of the most important objects of this institution to make a good map of the United States, without the aid of which no geological work can be carried on satisfactorily. On account of the wide extent of our country, this enterprise is enormous, and requires a long time for its accomplishment. By the co-operation of States the work which is of the greatest importance can be accelerated, and it is to be hoped that other States will follow the example set by three of their number, the good results of which may be seen from the map of New Jersey, so far the only one published.

THE GREAT STORM OF MARCH, 1888.

It is only after a long period has elapsed that it is possible to describe accurately the meteorological conditions that prevailed at a certain time over a large area, particularly over extensive parts of the ocean; therefore it has not been possible until recently to write the history of the great blizzard that visited the Atlantic States from March 11 to 14, 1888. Lieut. Everett Hayden, who is in charge of the Division of Marine Meteorology of the Bureau of Navigation, has undertaken this work, and presented the results of his interesting study in the fifth of the "Nautical Monographs." The book, which contains the original observations made by masters of vessels in full, is bound in leather to enable it to stand the rough handling incident to use aboard ship, where books in ordinary cloth bindings are quickly ruined. The list of observations shows how valuable is the aid that voluntary observers aboard ships give to the work of the Hydrographic Office. The history of this memorable storm is based almost exclusively on their reports: therefore the endeavors of the Hydrographic Office to enlist as great a number of masters as possible as voluntary observers, and to increase the general interest in marine meteorology among mariners, deserve the greatest possible success. It is well known how much more readily a man will undertake such observations if he knows that they are actually used, than if he believes that they are buried among a vast amount of material: therefore the plan of publishing a monograph of a remarkable gale, with a complete list of observations appended, will, aside from its scientific value, instigate many a mariner to continue or to take up meteorological observations at sea.

Lieut. Hayden represents the meteorological conditions over the Atlantic coast and the adjoining parts of the ocean in four charts, showing lines of equal pressure and of equal temperature. In order to make the maps clearer, temperatures above freezing are represented in pink; those below freezing, in blue; the depth of shade increasing with the departure from this point. In this way the advance of the cold wave from the interior towards the seacoast is shown with admirable clearness, and the meteorological events are easily understood. In the text, the history of the storm is traced from March 11, 7 A.M., when a long trough of low barometer, extending from the west coast of Florida up past the eastern shore of Lake Huron, and far northward, was advancing eastward, causing strong north-westerly winds on its western side. At 10 P.M. this line had advanced eastward as far as the 74th meridian. The cold north-westerly gale, as it is now sweeping over the great warm ocean-current, carrying air at a temperature below the freezing-point over water above 75°F. , is rapidly gaining strength, and be-

comes a fierce hurricane. An area of high barometer, which was at Newfoundland the previous day, is slowing down, blocking the advance of the rapidly increasing storm, and about to hold the centre of the line in check to the westward of Nantucket for days, while a terrific north-west gale plays havoc along the coast from Montauk Point to Hatteras, and until the right flank of the line has swung around to the eastward far enough to cut off the supply of warm, moist air pouring in from the north-east. The special value of Lieut. Hayden's description lies in his clear treatment of the influence of the warm, moist Atlantic air upon the development of the storm. He sums up the observations on this argument as follows: "The storm has called attention anew to the sudden deepening of depressions upon reaching the coast, and the corresponding increase of energy to be expected, — a lesson that should be borne in mind by every navigator leaving port with a falling barometer, and other signs of a storm. It has reminded us of the vitally important influence of the Gulf Stream in causing such increase of energy, and to the necessity of closely watching this great warm ocean-current, and noting any abnormal conditions of volume, velocity, temperature, and position; especially so during the spring and autumn months, — the periods of most rapid change in the conditions of oceanic and atmospheric circulation. The storm has established in most unmistakable terms the importance, not only to our extensive shipping interests, but to the people of all our great seaboard cities, of the establishment of telegraphic signal stations at outlying points off the coast, — at St. Johns and Sable Island, to watch the movement of areas of high barometer, upon which that of the succeeding 'low' so largely depends; and at Bermuda, Nassau, and various points in the West Indies and Windward Islands, that we may be forewarned of the approach and progress of the terrific hurricanes which, summer after summer, bring devastation and destruction along our Gulf and Atlantic coasts." Discussions like the present will contribute largely to arousing and keeping alive an interest in these researches, the practical and scientific value of which cannot be overestimated.

BOOK-REVIEWS.

Allen and Greenough's Latin Grammar. Revised by J. B. GREENOUGH and G. L. KITTREDGE. Boston, Ginn & Co. 12^o. \$1.35.

ADVANTAGE has been taken of the opportunity offered by the necessary recasting of the plates of this book to have such improvements made in it as the advance of grammatical knowledge and the experience of the schoolroom have shown to be advisable. The revisers have simplified the statement of principles, so far as a preservation of strict correctness would admit, but without any approach to a mechanical method of treating the science of language. Many explanations and suggestions, in text and footnotes, have been added to those given in previous editions, for the benefit of teachers and advanced scholars.

In the revision of this work, the needs of the classroom have evidently been kept constantly in view, resulting in great accuracy, combined with clearness and simplicity of statement. Although the matter of the book has been simplified, the size of the book has been increased, for simplification sometimes necessitates expansion. Many things taken for granted or merely suggested in the old edition have been expressly stated in this revision. Much new matter will be found, marking, in many particulars, a substantial advance. Thus, the chapter on word-formation has been entirely rewritten, many new points being presented; the treatment of the temporal particles has been recast; the section on reflexive pronouns has been rewritten; and the chapter on words consists in great part of new matter.

Some other subjects, in the treatment of which the new edition will be found more satisfactory than the old, and to which the especial attention of both student and teacher may be called, are included in that part of the book between Sections 248 and 332. There is also much new philological matter, which is nearly all printed in small-type notes, being intended more for the advanced student than the beginner.

Very numerous cross-references have been furnished in this edition, by means of which the ramifications of a construction,

etc., can readily be traced. In the same way references have been inserted in the grammatical analyses at the head of each chapter.

Typographically the present edition is a great improvement on the old. The pages are much more open and pleasing to the eye; section-headings have been used, and the paradigms have been printed in large full-faced type; important words in the examples are distinguished by the use of black type, and the size of the note type has been reduced, so that there is more difference to the eye than formerly between the text and the notes. The index of words and subjects is enlarged and revised, a separate index of verbs has been added, the glossary of terms has received additions, and the list of authors has been divided into periods. The list of important rules of syntax has been made more complete, and furnished with references to the body of the book, and in its present form will furnish pupils with a convenient and accurate summary. With a few exceptions at the beginning of the book, the section-numbers of the new edition correspond with those of the old, so that references to either are good for the other.

A Text-Book of General Astronomy. By CHARLES A. YOUNG. Boston and London, Ginn & Co. 8°. \$2.40.

THE present work is designed as a text-book of astronomy suited to the general course in our colleges and schools of science, and is meant to supply that amount of information upon the subject which may fairly be expected of every liberally educated person. Therefore it contains no proofs of astronomical theorems, except such deductions as can be explained by the use of elementary algebra, geometry, and trigonometry; its aim being to give a clear, accurate, and justly proportioned presentation of astronomical facts, principles, and methods in such a form that they can be easily apprehended by the average college student.

The author has fully accomplished his object, and his work is excellently adapted to the purposes of teacher and student, the matter being arranged systematically, and presented clearly. A great number of carefully selected illustrations enhance the value of the book and add to its clearness. After a brief introduction, in which the more important definitions are given, the author describes the principal astronomical instruments, the methods of observation, and the corrections of astronomical observations. After the discussion of a few problems of practical astronomy, such as determination of latitude and longitude, the dimensions and shape of the earth and the methods of its determination are described. After explaining the phenomena of the earth's orbital motion, the author proceeds to a description of the movements and physical character of the moon and sun. A special chapter is devoted to eclipses. It is only after the description of these movements that the author takes up the forces causing these motions. He discusses the law of gravitation and the important "Problem of Three Bodies," giving a very clear definition of perturbations. Then the planets are described. Before considering the fixed stars, comets and meteors, and the numerous unexplained phenomena and processes observed in these bodies, are treated in a comprehensive chapter. The book concludes with a discussion of the nebular hypothesis. This brief synopsis shows that the book is thoroughly methodical in its arrangement, and will therefore prove very useful for teachers and students.

The Australian Ballot System. By JOHN H. WIGMORE. Boston, Charles C. Soule. 8°. \$1.

THE object of this work is to describe the method of voting devised by Francis S. Dutton of South Australia, which seems likely to be adopted wherever representative institutions prevail. It has been practised in Australia for thirty years, and was adopted in England in 1872, and soon afterwards in Canada and Belgium. Last year it became the law in Massachusetts; and bills embodying its provisions have been introduced into the legislatures of New York and many other American States. Its essential characteristics are now pretty generally known. The names of all the candidates for a particular office are printed on the same slip of paper, and the voter marks a cross (x) against the name of the person he wishes to vote for. The ballots are printed at public expense, and distributed by public officers. The voter is required to mark his

ballot privately, so that absolute secrecy is secured. The object, and the effect wherever the system has been tried, is to put an end to bribery and intimidation. It being impossible to ascertain how a man votes, you cannot bribe or coerce him to vote as you wish. Mr. Wigmore here gives us a brief history of the system since its origination in Australia, with the arguments in its favor, and then presents in full the statute of Massachusetts, with the essential portions of the South Australian, the English, and several others. He gives also a specimen ballot according to the Massachusetts law, and also a full description, with illustrative cuts, of the mode of voting. Altogether his book contains the most complete and accurate account of the system we have anywhere met with, and may be cordially commended to all interested in political reform.

- (1) *Die Rolle der Suggestion bei gewissen Erscheinungen der Hysterie und des Hypnotismus: Kritisches und experimentelles.* Von Dr. ARMAND HUECKEL. Jena, 1888.
- (2) *Ueber hypnotische Suggestionen, deren Wesen, deren Klinische und Strafrechtliche Bedeutung.* Von JOH. G. SALLIS. Berlin, 1888.
- (3) *Der Hypnotismus und seine Strafrechtliche Bedeutung.* Von Dr. AUGUST FOREL. Berlin and Leipzig, 1888.
- (4) *Eine experimentelle Studie auf dem Gebiete des Hypnotismus.* Von Dr. R. v. KRAFFT-EBBING. Stuttgart, 1888.
- (5) *Ein Beitrag zur Therapeutischen Verwerthung des Hypnotismus.* Von ALBERT, FREIHERRN V. SCHRENCK-NOTZING. Leipzig, 1888.
- (6) *Ueber Hypnotismus.* Von Dr. HERING. Berlin, 1888.
- (7) *Hypnotismus und Willensfreiheit.* Von F. MIESCHER. 1888.
- (8) *Der Hypnotismus in der Paedagogik von einem Schulmanne, und mit einem Vorwort.* Von JOH. G. SALLIS. Berlin, 1888.
- (9) *Hypnotismus und Wunder; ein Vortrag mit Weiterungen.* Von MAX STEIGENBERGER, DOMPREDIGER. Augsburg, 1888.

THE science of modern hypnotism is distinctly of French origin. The greatest of charlatans in this field, who disturbed the peace of so many credulous souls, won his fame and fortune in Paris; and it was in Paris that the successful steps were taken to atone for this injury by bringing these curious and startling phenomena into scientific repute. The movement, once started, grew rapidly, — indeed, with an almost morbid rapidity, — and within the last year or two the phenomena announced as demonstrated among the highly sensitive and very plentiful subjects of Paris seem marvellous, and threaten to overturn or vastly extend the tenets of science. Among much that is strange, much that is new, much that is false, and much that is true, it is difficult to know what to credit, and what to reject.

As has happened often before, the lookers-on are better judges than the players, and the Germans have assumed the attitude of critics. Not as liable as their enthusiastic neighbors to lose self-control in the whirl of interest, they have been calmly sifting the evidence, and assimilating the new to the old, rather than magnifying the novel into the mysterious. For this reason a review of recent German works upon hypnotism — of which those mentioned above form a typical selection, though only a selection in this rapidly increasing literature — may be of service in acquainting an American public with the true aspect of hypnotic research.

Dr. Hückel's pamphlet (1) is doubtless the most important on this list, and deals with the central point of discussion, — the issue between the school of Paris, headed by Charcot, and the school of Nancy, of which Dr. Bernheim may be declared the leader. The former hold that the hypnotic condition is induced by physical causes, such as passes, pressures, etc.; that there are three stages of hypnosis well differentiated, the passage from one to the other being accomplished by physical manipulations (closure or opening of the eyelids, pressure upon the vertex); that the phenomena assume their most typical form, and should be studied in hysterical patients; that the magnet has a distinct physical effect upon sensi-

tive subjects; that such also re-act to the physical effect of drugs when applied at a distance; and that even a certain degree of transfer of mental states is possible in a few subjects.¹ The school of Nancy recognize in all hypnotic states various forms of suggestibility: they regard the phenomena as purely psychical in origin; refuse to admit any supernatural powers or super-physical effects, such as those of the magnet; and explain all such points as due to more or less unconscious suggestion. Dr. Hückel proposes to show that the latter position is capable of accounting for all the observed facts, as well as the flaws in the conclusions and methods of the Paris experimenters. In the first place, all the effects claimed as of physical origin have been obtained by direct suggestion. This shows, at least, that the latter is as powerful an agent as the former. Moreover, the same manipulations have not produced the same results at Paris and elsewhere. Some comprehension by the subject of what is to result seems indispensable. But the important point remains of explaining the Paris results on the suggestion hypothesis. The keynote here is "unconscious suggestion" on the part of the operators, and shrewd anticipation on the part of the subjects. Take the alleged action of metals as an instance. In several cases gold alone brought about the desired effect. The most precious of the metals is, by a very natural analogy, regarded as the most efficacious, and this same preference will be quite general. How little specific influence the gold has, is shown by the fact that gold believed to be copper had no effect, while copper believed to be gold worked quite as well as the genuine metal.

When attention is directed to the patient's arm, it is not surprising that she should expect something to occur with the arm, and, if previously it has been rendered insensitive, it becomes so now. When attention is directed to the other arm, the phenomenon is "transferred." Another very vital influence is contagion. One subject sees the other, or hears of her actions, and exhibits the same results. An *esprit de corps* is thus formed, and this applies especially to the dozen subjects with whom Charcot has done almost all his work. It is almost impossible to realize how stringent the conditions must be to rule out unconscious suggestion. One's expression; tone of voice; manner; choice of words; evidence of interest, of surprise, of satisfaction, — any of these, entirely unconsciously given, may vitiate an entire experiment. A good case is that of a patient seated for three-quarters of an hour in close proximity to a magnet (unknown to herself) without exhibiting any signs of being affected by it, but re-acting promptly when informed of its presence. This must suffice to indicate the line of criticism of this most valuable pamphlet. It gives a surprising glimpse into the subtleness of psychic impressions, and gives an importance to the term "suggestion" not previously realized. One may take as the motto of the Nancy school the saying that another writer prefixes to his work on hypnotism, — "Possunt quia posse videntur."

In a subject that is comparatively new and unusually open to misunderstanding, general expositions and addresses will naturally find a public. To this class belongs the pamphlet by Dr. Sallis (2), with a convenient scheme of classifying the phenomena as motor (those that affect the muscles, such as rigidity, paralyses, contractions, and the like), as sensory (affecting the senses, such as anesthesia, special and general, suggested blindness, deafness, etc.), and vegetative (affecting organs normally removed from voluntary control, such as the formation of scars and blisters by imaginary burns, the slowing of the heart-beat, the oozing of blood through the skin). In addition to this exposition, the legal and curative effects are well described, and the pamphlet adds another to the many convenient summaries already extant. The point of view is that of the Nancy school throughout.

The essay of Dr. Forel (3), the eminent alienist and naturalist, is more general than its title would suggest. In order to acquaint the legal profession with the aspects of hypnotism of especial import to them, a general exposition is necessary. This is lucidly sketched with many forcible distinctions. Dr. Forel is a staunch adherent of the Nancy school, having derived his experience from Dr. Bernheim himself. He insists upon the close relation between hypnotic and mere normal states. When we ordinarily go to sleep,

we assume an accustomed attitude, in an accustomed place: all this is auto-suggestion. We suggest sleep to ourselves, and, unless distractions refuse to allow us the necessary concentration of mind, we follow the suggestion. Education, too, is largely a matter of suggestion skillfully applied. The educator's tact is the impressiveness of his suggestions. Some persons more readily subject themselves to the direction of others; they are the weak of will, that follow: while others seem Napoleon-like, born to command; their very manner enforces obedience.

The dangers of suggested crime in hypnotic conditions are just so much greater as the suggestions are more readily carried out. This is a serious problem, with which the law courts will soon be found to busy themselves. Especially in post-hypnotic suggestions, when the patient fully believes himself acting from his own motives, and sternly denies any possibility of suggestion, is the danger difficult to meet. The condition seems to demonstrate the truth of Spinoza's dictum, that the illusion of free will is merely the ignorance of the motives of our actions. Dr. Forel partly removes the danger by suggesting that none other but himself can hypnotize the subject; but even this is not a full guaranty. The topic is not yet in a satisfactory condition.

The pamphlet by Dr. Kraft-Ebbing (4) illustrates another mode of studying hypnotism: it is by a close observation of the phenomena in a single case. The patient has a remarkable history of hysteria, and has led an adventurous and irregular life. The right side of her body is insensitive, and she readily falls into the hypnotic condition by suggestion, or even of her own accord. Her control over involuntary functions is especially remarkable. If a characteristic shape, such as a letter of the alphabet, a pair of scissors, a glass cylinder, be held against the skin with the suggestion that it is red-hot, a burn and scar are formed in the shape of the object applied. The healing of this scar can be decidedly hastened by suggestion, and it can even be made to transfer itself to the symmetrically situated spot on the other side of her person. This is, of course, an extreme case. She responds to the action of a magnet (by violent contractions); but as this power is shared by any object in contact with a magnet, and only when the magnet is in the hands of Dr. Kraft-Ebbing, suggestion (perhaps by temperature changes) is the obvious explanation. The action of drugs at a distance failed entirely in her case. She easily accepts fantastic negative hallucinations, — such as that only the head and arms of a spectator are visible, the appearance causing great consternation, — as well as foreign personalities, changing her attitude and even her handwriting to suit the suggested character. Her time-estimates are strikingly exact. She will sleep an exact number of hours suggested, and so on. In brief, we have here a morbidly sensitive subject, and a typical case of the kind of hypnosis liable to accompany pronounced hysterical epilepsy.

The special study of the therapeutic aspects of hypnotism by the Freiherr von Schrenck-Notzing (5) gives one an admirable idea of the extensive activity in these studies. It is mainly devoted to a *résumé* of recent contributions. France and Germany are naturally most extensively noticed; but Belgium, Holland, Austria, Italy, Spain, England and America, Greece, Hungary, Poland, Russia, Norway, Sweden, Denmark, Switzerland, are all represented. There is a special review of hypnotism in France, and one in Spain, and a hospital for the cure of disease by hypnotism has been opened at Amsterdam. Much space is devoted to statistics of cures by hypnotism, the large percentage of successful treatments leaving little doubt of its therapeutic value. Its influence is most marked upon nervous diseases, though by no means restricted to such. The author is careful to caution against a too free use of hypnotism, and insists upon its restriction to professional specialists.

The part that the travelling mesmerist plays in the progress of hypnotism is altogether a dangerous one, and such public exhibitions have been prohibited in the chief countries of Europe. One point in their favor, however, is that they have so often served to arouse interest in the phenomena, and thus promote their scientific consideration. Dr. Hering's lecture (6) is a case in point. Its object is simply to satisfy local curiosity in the matter, — a laudable object, but very imperfectly carried out. His facts lack order, and the uncertain is jumbled together with the well-ascertained: — No

¹ These last three points would not be indorsed by all the adherents of the Paris school.

particular point of view is represented, the whole treatment being rather amateurish.

Very different in character is the address of Professor Miescher (7). After a clear history of hypnotism, showing its analogies with previous psychic doctrines, and with especial consideration of the work of Dr. Braid and Dr. Liebault, the author describes the chief well-established phenomena from the standpoint of the Nancy school. To this he adds a consideration of the will in hypnotized subjects. We have a state of automatism, in which every impulse must realize itself, but it is an automatism varying in degrees. Not all self-control is lost, any more than in sleep; the loss, too, is quite similar to what occurs in normal conditions. None the less it illustrates how closely a practical freedom of the will is connected with physical conditions, and how readily a state of irresponsibility may be induced.

The anonymous philologist introduced by Dr. Sallis (8) treats a question upon which the French have written much. They have advocated the introduction of hypnotism into the schoolroom to cure wayward children of bad habits. Laziness, pilfering, physical weaknesses, moral foibles, — all have yielded to this all-powerful agent; and an hypnotic moralization seems to be regarded as the automatic educator of the future. It is against this growing opinion that the author writes. He points out the obvious dangers of such a process, hints at cases in which children have learned to hypnotize one another, and urges that its use should be confined to distinctly abnormal children, requiring an abnormal treatment. Education has developed more natural methods of curing such defects, and so peculiar a cure as hypnotism should not be allowed to usurp their place.

As a final illustration of the ramifications of hypnotism, the last pamphlet on our list (9) will do service. The church enters the arena of hypnotism. A passing analogy between the trance states found among hypnotics and the religious ecstasies of saints is sufficient to arouse in Domprediger Steigenberger a fear lest the accredited church miracles will lose their hold upon the people. He thereupon denounces hypnotism as the work of demons, and proceeds to show how different is the basis of the miracles, and ends by claiming, that, inasmuch as hypnotism is avowedly incapable of explaining *all* the wonders of history, it is idle to consider it at all. With such different methods of reasoning, a sympathy between church and science in this topic could hardly be expected; but the shape this mutual misunderstanding takes is interesting.

From this review, however cursory, it is easy to gather some notion of the vastness of the researches still to be elaborated in this field, of the many-sided interests the problems present, and no less of the complicated pitfalls that beset their solution on all sides. Moreover, it may not be too hazardous to claim that one of the great controversies of hypnotism is about settled, — the issue between the Paris and the Nancy schools, the balance of evidence and opinion being decidedly in favor of the "suggestionists."

The English Restoration and Louis XIV. By OSMUND AIRY. (Epochs of Modern History.) New York, Longmans, Green, & Co. 16°.

THIS work labors under a disadvantage, in that its subject is not really an epoch. In English history, indeed, the age of Charles II. may be considered an epoch, though not a very important one; but in the general history of Europe it was rather the close of one epoch and the beginning of another. The earlier chapters of Mr. Airy's book deal with the wars of the Fronde in France, which resulted in the definite establishment of absolutism; while the rest of the work treats of the early years of Louis' reign, but breaks-off in the midst of his career. The author, however, has perhaps done as well as could be expected with such a theme, and he shows a clear grasp both of English and of European politics in the period of which he treats. The principal fault of the work is one common to most short histories, — an excessive amount of detail. This is specially conspicuous in the treatment of military affairs and court intrigues, the details of which are of little interest to the reader, though it must be admitted that court intrigues were more important in those days than they are now. Mr. Airy's style is good, and his judgment of men and events marked by good sense and impartiality. His chapters on the Fronde show how different that

movement was from the English revolution; and how inferior in interest; while, on the other hand, he does not fail to point out the ecclesiastical bitterness of the English Parliament after the restoration of the monarchy. In the general politics of Europe the chief interest centres, of course, in the ambitious schemes of Louis XIV., — in his contest with Spain and the Dutch Republic, on the one hand; and his intrigues with the king of England, on the other. The breaking-off of the narrative, however, in the flush of Louis' career, makes it impossible to give a complete picture; and the reader will have to turn to other volumes of the series for the conclusion of the story.

Master Virgil. By J. S. TUNISON. Cincinnati, Robert Clarke & Co. 8°. \$2.

IT is well known that during the middle ages a number of legends connected themselves with the name of Vergil. As a companion of the Devil, as a magician, and as a learned and competent physician, Vergil was presented at various times and by various writers. These legends and their history are curious in themselves, and interesting as indices of certain obscure phases of mediæval thought. Mr. Tunison has, at great labor, collected a vast amount of information on this subject, and now presents it in these interesting essays. The book is too learned to be popular, but it will have a cordial reception from men of letters.

AMONG THE PUBLISHERS.

THE February number (No. 40) of the Riverside Literature Series (published monthly at 15 cents a number by Houghton, Mifflin, & Co., Boston) contains "Tales of the White Hills" and "Sketches by Nathaniel Hawthorne." The "Tales of the White Hills" are "The Great Stone Face," a story about the Profile or Old Man of the Mountain, which is one of the most powerful and famous imaginative writings in all literature; "The Great Caruncle," founded on a wild and beautiful Indian tradition about the existence of a wonderful gem called by that name; and "The Ambitious Guest," an imaginative story of the memorable mountain-slide in Crawford Notch in 1826, which destroyed the whole Willey family, but left intact their house, from which they had fled in fright. The sketches comprise, "Sketches from Memory," "My Visit to Niagara," "Old Ticonderoga," and "The Sister Years."

— D. Lothrop Company will publish shortly, in their Story of the States Series, "The Story of Vermont," which will be of interest, as there has been no history of the Green Mountain State published for forty years. John L. Heaton, the author, is a well-known Brooklyn newspaper man, and is one of the many editors born and brought up in Vermont.

— Thomas Whittaker announces that the next volume in the Camelot Series will be "Essays of William Hazlitt;" in the Canterbury Poets, "Poems of Dora Greenwell;" and in the Great Writers, "Life of Schiller."

— William R. Jenkins has just published "A Chinese and English Phrase-Book for the Chinese to learn English," which is perhaps the first book with Chinese characters published in America. Its compilers are Dr. T. L. Stedman and K. P. Lee; and, while it is unpretentious in its character, it is excellently adapted to furnish Chinamen with a large vocabulary of colloquial phrases. The first edition of five hundred copies, though only just published, has been taken up so quickly that a second edition is already in the press.

— Alphonse Picard, of 82 Rue Bonaparte; Paris, is publishing an important historical work that will be of value to collectors of Americana. It is entitled "Histoire de la participation de la France à l'établissement des Etats-Unis de l'Amérique." The author is Henri Doniol, directeur of l'Imprimerie Nationale. Three volumes are now ready, covering the years 1775-79. These explain the efforts of the ministers of Louis XVI. to influence Spain to enter into the alliance against England, which went into effect after the first victories by the Americans over the English, — an alliance which later indirectly was the cause of the famous League of Nantes. The book is published by the French Government in connection with the Universal Exhibition which is to take place in Paris next

summer. It is intended to make the book a specimen of the work of the National Printing-Office.

— "The Last Journal" of the late Lady Brassey will be published here at once by Longmans, Green, & Co. It contains an account of the trip of the "Sunbeam" to India, Borneo, and Australasia. The publishers, at Lord Brassey's request, have sought to make this one of the most sumptuous volumes of late years. It is elaborately illustrated from drawings by Mr. R. T. Pritchett and from photographs. The woodcuts have been done by the best English engravers; and variety and novelty have been gained by the insertion of some forty monotypes executed in lithography.

— Sir Charles Dilke has been travelling in India, and will present the results of his observations in the March and April numbers of the *Fortnightly Review*. The articles will be of a military character, dealing with the strategical defences of the empire. This review is now issued from New York by the Leonard Scott Publication Company.

— "The Harvard Index for 1888-89" (Vol. XV.) is now ready. This is a complete university directory of officers and students, with complete athletic, base-ball, foot-ball, and boating records, and lists of officers and members of the college societies, the class secretaries, the officers of the Harvard clubs, the holders of academic honors, etc., and is published by the Harvard Index Company, Cambridge, Mass.

— The *Edinburgh Review* for January contains an article on Krakatoa, in which the German and English reports on the great eruption are reviewed.

— We learn from the *Publishers' Weekly* that a meeting of the executive committee of the Jewish Publication Society of America was held on the 21st of January, in the vestry-room of the Temple Emanuel, Fifth Avenue and Forty-fourth Street, New York. The following members were present: the Rev. Drs. Gottheil and Kohut of New York; the Rev. Drs. Jastrow and Krauskopf of Philadelphia; Judge Rosendale of Albany; Jacob H. Schiff, Professor Henry M. Leipziger, Benjamin F. Peixotto, of New York; Professor Charles Gross, Harvard College; Professor Cyrus Adler of Baltimore; Myer Sulzberger, Morris Newburger, S. A. Stern, S. Friedman, Ephraim Lederer, and Miss Mary M. Cohen, of Philadelphia. President Newburger presided, and submitted a roll of nearly one thousand members already subscribed in the States of New York and Pennsylvania. Committees were appointed on membership in the principal cities of the Union. Popular works on Jewish history and literature will soon be published. Membership costs \$3 a year; patrons, \$20; life membership, \$100. Messrs. Schiff of New York, and Guggenheim of Philadelphia, contributed \$5,000 each toward a "Michael Heilprin" fund, the interest only to be used. This fund, started by Jacob H. Schiff, is to be augmented to \$50,000.

— Under the heading "Another Learned Shoemaker," the *Publishers' Weekly* tells of Mr. John Mackintosh, author of "The History of Civilization in Scotland," who will write the volume "Scotland" in the Story of the Nations Series, who is in many respects a remarkable man. He was sent to work on a farm in his native county of Banff at ten years of age, and was subsequently apprenticed to shoemaking, at which trade he worked in various parts of Scotland for fourteen years. In 1869 he opened a small stationary shop in Aberdeen, "and there, on the shop counter," he once wrote, "amid all the noise and bustle of a stirring thoroughfare, the three volumes of my history were written and the proof-sheets corrected and revised, all being done while customers were coming in and out and constantly interrupting me."

— Albert S. Gatschet has published the second volume of his valuable book, "A Migration Legend of the Creek Indians," the first volume of which appeared three years ago in Brinton's Library of Aboriginal American Literature. The present volume is a reprint from the "Transactions of the Academy of St. Louis." It contains the carefully revised text of the speech of Chekilih, chief of the upper and lower Creek, delivered in 1737 at Savannah, before Governor James Oglethorpe, in the presence of several other chiefs. This speech was originally written on buffalo-skin, and sent, together with an

English translation, to England, where it was deposited in the Georgia office at Westminster. All attempts to find the original or the translation have been in vain. Fortunately, however, a German translation of this valuable document is extant. It was made by P. G. F. Von Beck, the commissioner of the Salzburg protestants, who, after having been expelled from their home, had immigrated to America. It has been reprinted in the well-known work of Samuel Ursperger, "Ausführliche Nachricht von den Salzburgernt Emigranten, die sich in Amerika niedergelassen haben." Dr. D. G. Brinton translated this speech back into English, and this translation served for the reconstruction of the original speech. Judge G. W. Stidham of Eufaula, Indian Territory, a Hitchiti Indian, undertook this arduous task in both the Creek and Hitchiti dialects. These two translations are contained in the present volume. The texts are followed by a short commentary and a very full dictionary of both dialects. A sketch of the Creek grammar was published in the first volume of this work. While these two chapters make the work indispensable for the linguist, the student of folk-lore will be greatly interested in the discussion of the track of the Kashihta migration. The present volume is accompanied by two valuable ethnological maps showing the location of Indian tribes at the time of the discovery. The work may be obtained from the author, P.O. box 591, Washington, D.C.

— *Shakespeareana* will begin in an early number a teachers' supplement, designed as an exchange among teachers for suggestions, opinions, and experiences in imparting instruction in English literature by means of the works of Shakespeare as a text-book.

— The *Fortnightly Review* for February contains a paper by Mrs. Lynn Linton on "Characteristics of English Women." It is the first of a series which begins historically. Mrs. Linton's papers on "Women in Greece and Rome" were a marked feature of the *Fortnightly* last year.

— *Blackwood's Magazine* for February opens with an article, accompanied with two maps, on "Major Barttelot's Camp on the Aruvimi," which will be found of interest in connection with recent events in Africa. Other notable papers are a review of the life of Titus Oates and the famous "Popish plot," a sketch of Minacoy, a sympathetic notice of Laurence Oliphant by Mrs. Oliphant, and a remarkable story of the Vigilance Committee at San Francisco, entitled "A Philanthropist." Additional chapters of the new novel "Lady Baby" are given, and the miscellaneous articles are of more than usual interest.

— S. A. Moran, principal of the Stenographic Institute, University of Michigan, Ann Arbor, has in preparation a "Type-Writer Dictionary," the object of which is to show the proper spelling and division into syllables of the more commonly misspelled and misdivided words.

— The Moses King Corporation, Boston, has in active preparation "King's Handbook of the United States." It is to contain 520 pages of text, maps, and more than 1,200 small original illustrations. There will be 50 full-page maps, one of each State and Territory, and a double page of the United States, printed in three colors. This book attempts to answer clearly and fully the demands for a general description and a popular history of the United States. The text is being prepared by M. F. Sweetzer, the Boston *litterateur*, and author of many guide-books, etc.

— The "Teachers' Manuals Series," published by E. L. Kellogg & Co. of New York and Chicago, has three new numbers: No. 11, "Argument for Manual Training," by Dr. Nicholas Murray Butler; No. 12, "Temperament in Education," by Dr. Jerome Allen; and No. 13, "School Hygiene," by President G. G. Groff of Bucknell University, Lewisburg, Penn.

— The *School Journal* of New York is publishing a number of valuable monthly four-page supplements, by Hughes, Quick, Allen, Butler, Groff, etc.

— In *The Phrenological Journal and Science of Health* for February, three women are sketched, and portraits of them given: viz., Mary A. Ward, author of "Robert Elsmere;" Margaret Deland, author of "John Ward, Preacher;" and the almost as well known Henrietta H. Skelton, author, and prominent advocate of temper-

ance reform. An analysis of the octogenarians of Massachusetts, and a story of heredity, are full of hints.

— "Sleeplessness in Infancy" is the subject of an article by Dr. M. Allen Starr, professor at the College of Physicians and Surgeons, New York, in the February number of *Babyhood*. "The Causes of Common Colds," by Dr. William H. Flint; "A Mother's Frights," by Mrs. E. W. Babcock; and "A Reformed Primer," by Mr. Louis Heilprin, — are the other leading articles.

— Ticknor & Co.'s February books include a novel by the author of "The Story of Margaret Kent," "A Daughter of Eve;" "Safe Building," by Louis De Coppet Berg, Series I.; and in their paper series, "The Desmond Hundred" (No. 51), by Jane G. Austin (ready Feb. 2), and "A Woman of Honor" (No. 52), by H. C. Bunner (ready Feb. 16).

— *The Contemporary Review* for February (New York, Leonard Scott Publication Company) contains an article entitled "The Bismarck Dynasty," which is unsigned, but is attributed to Sir Morell Mackenzie, and is supposed to have been inspired by the Empress Frederick. It reviews many of the incidents preceding the death of the late emperor, as well as those that followed that event. It is not sparing in its criticism of the present emperor, and calls him an apt pupil of a cynical master, who found no difficulty, moral or sentimental, in treating his mother in a fashion after Count Herbert's own heart, and in treating the Prince of Wales with such discourtesy as to prevent any intercourse between them. The article goes freely into the Geffcken and Morrier affairs.

— The new and forthcoming books of D. Appleton & Co. include "Capital: A Critical Analysis of Capitalist Production," by Karl Marx, translated from the third German edition; "Nature and Man: Essays, Scientific and Philosophical," by the late William Benjamin Carpenter, with an introductory memoir by J. Estlin Carpenter, M.A., and a portrait; "The Florida of To-day: A Guide for Tourists and Settlers," by James Wood Davidson, with railway and county map printed in colors, and illustrations; "Appletons' Cyclopædia of American Biography," edited by James Grant Wilson and John Fiske, Volume VI. (completing the work); "Mental Evolution in Man: The Origin of Human Faculty," by George John Romanes; "The Folk-Lore of Plants," by T. F. Thielton Dyer; "A Dictionary of Terms in Art," fully illustrated; "The Development of the Intellect," Part II. of "The Mind of the Child," from the German of W. Freyer (International Education Series); and "Co-operative Building and Loan Associations," by Seymour Dexter.

— A recent number of the *Geographisches Jahrbuch* contains a list of the geographical chairs in the universities of different countries. Germany, as before, takes the lead with nineteen chairs. In Austria-Hungary there are fourteen. Denmark has an extraordinary professorship. In France there are nineteen professorships and lectureships connected with the various universities, besides seven lectureships in special institutions. Great Britain figures in the list with two chairs. In Italy there are thirteen professorships; in Holland, one; in Russia, three; and in Switzerland, two.

— The Brooklyn Ethical Association have begun the publication of a series of lectures on the subject of evolution, under the general title of "The Modern Science Essayist;" and the first number of the series, by Daniel Greenleaf Thompson, on "Herbert Spencer," has just been issued by The New Ideal Publishing Company of Boston. It is popular rather than scientific, the object of the lectures being to propagate the evolution doctrine among the masses. Mr. Thompson is evidently a thoroughgoing evolutionist, not only in biology and history, but also in ethics and religion, and he puts Mr. Spencer on the highest pinnacle of fame, declaring him to be "much greater than either" Plato or Aristotle, though he condescendingly admits that these men were "really worthy Greeks, who would be considered good philosophers, as philosophers go in our time." A part of this lecture, or essay, is occupied with biographical and personal anecdotes of Mr. Spencer, which every reader will find interesting; and the rest gives a brief summary of his leading doctrines, with special stress on their religious and ethical bearings. The second paper of the series will relate to Darwin, while the

succeeding ones will deal with various aspects of the evolution philosophy.

— Professor Nicholas Murray Butler has given to the public his "Argument for Manual Training," originally read before the American Institute of Instruction, and the pamphlet is published by E. L. Kellogg & Co. of New York. Professor Butler is an enthusiast on the subject of which he treats, and declares that "a movement at once so philosophic and so far-reaching as that in favor of manual training has not come into educational thought since Comenius burst the bonds of mediævalism two and a half centuries ago." He holds that under our present system of education there is no adequate training of the executive and constructive faculties, and that the defect can only be supplied by regular manual exercises in the common schools. His arguments in favor of the system are not specially new, but they are clearly and forcibly presented, and will be interesting to educators everywhere. An appendix to the pamphlet gives a brief summary of the course of manual training that has been followed for some time in the schools of Jamestown, N.Y., so that those not already familiar with the system can see what it is.

— Mrs. Oscar Wilde appears as a contributor to the *Woman's World* for March (Cassell & Company), as does the famous novelist "Ouida" and the equally famous author of "How to be Happy though Married."

— In *The Truth Seeker* of Feb. 16 will be published "The Limitations of Toleration," a discussion between Col. Robert G. Ingersoll, Hon. Frederick R. Coudert, and Gov. Stewart L. Woodford, before the Nineteenth Century Club of New York, stenographically reported for *The Truth Seeker* by I. N. Baker. The publication of this discussion has been delayed from various causes. F. R. Coudert is a Roman Catholic, and one of the best orators of New York. Gov. Stewart L. Woodford is a Protestant, and a splendid speaker. The discussion is the only oral public debate ever engaged in by Col. Ingersoll. He had the opening and the closing of the argument, and made two of his most forcible and eloquent speeches. President Palmer's introductions of the orators will also be given.

— The three methods employed for making window-glass will be described and pictured in *The Popular Science Monthly* for March by Professor C. Hanford Henderson of Philadelphia. Dr. Andrew D. White will conclude the subject of "Demoniacal Possession and Insanity," which forms one of his "New Chapters in the Warfare of Science," now publishing in that magazine. The forthcoming article will tell how the Roman Catholic, Lutheran, and Calvinistic clergy vied with each other, in exorcising and persecuting the unhappy victims of insanity, and how medical science slowly introduced more humane treatment, and finally drove back superstition from this part of the great battle-field. The relations of "Competition and the Trusts" will be discussed by Mr. George Iles, who first points out the great waste of effort and other losses, due to competition, and takes the ground that the trusts have, on the contrary, reduced the costs of business, and hence, if duly regulated, can serve the public better than competition. Many educators, who would be glad to use science in the training of young pupils if they knew just how to go about it, will be interested in the practical directions given in an article on "Natural Science in Elementary Schools," by J. M. Arms. Mr. Arms writes with a full appreciation of the true aims of science-teaching, and from an experience of ten years in the work.

— The *Nineteenth Century* for February (New York, Leonard Scott Publication Company) contains Professor Huxley's famous article on agnosticism. An interesting symposium is given on noticeable books, with contributions by Mr. Gladstone, Frederic Harrison, Rowland E. Prothero, W. S. Lilly, Augustine Birrell, Hamilton Aidé, the Rev. Dr. Jessopp, and Mr. Morley. Further comments are given on the relation of examination to education, by W. Baptiste Scoones, Hon. Auberon Herbert, Sir Frederick Pollock, Sir Joseph Fayer, Francis Galton, Dr. Priestley, and the Bishop of Carlisle. Among other contributions is one from his Majesty the King of Sweden and Norway.

LETTERS TO THE EDITOR.

*. *Correspondents are requested to be as brief as possible. The writer's name is in all cases required as proof of good faith.

Twenty copies of the number containing his communication will be furnished free to any correspondent on request.

The editor will be glad to publish any queries consonant with the character of the journal.

Tornadoes: Fact vs. Fiction.

THERE is no subject in meteorology of more absorbing interest than this. As our knowledge of the environment of tornadoes increases, there must necessarily be modifications in our views of their origin. One of the more recent and most significant of these changes has been the transference of the cool northerly wind, meeting the warm south wind, from the earth's surface to the upper regions, where it is said to overflow the lower current, and produce an unstable equilibrium in the atmosphere. It would seem as though no subject can demand, more strongly than this, a solid substratum of fact; and yet, strange to say, the theories and speculations about these terrible visitors have been far more extensive than the facts. This seems a favorable time to state a few of the more prominent facts and seeming fictions. The facts are these:—

1. It has been well said that the most important recent development has been the fact that tornadoes occur, not at the centre of a general storm, but about four hundred miles to the south-east. This fact was known fifteen years ago, but was first strongly emphasized in March, 1884.

2. All currents in this region, even up to a great height, are from the south before the tornado, as is well known from observations of the upper clouds.

3. The tornado invariably moves to the north-east; and if, as some believe, it takes its motion in the upper current, that must be from the south-west, and cannot be from the north even after the tornado.

4. The pressure rises in a tornado, as has been observed a few times in it, and it invariably rises at the centre of a thunder-storm, which frequently develops into a tornado.

5. That some other force than a violent gale blowing into a partial vacuum is concerned in the destruction, is well shown by the fact, that of two free barrels side by side, one of which was empty and the other full, the former was left undisturbed, while the other was completely obliterated. Fowls have been stripped of their feathers, and people deprived of their clothing, which could not be brought to pass by the most violent gale.

6. The tornado is extremely sudden, and, advancing without any warning, it interjects itself into a region of gentle southerly winds. After it has passed, the southerly wind almost at once again predominates. The whole appearance is as though a disturbance, largely having its own source of energy, had suddenly projected itself into a quiet air, and passed on without bringing about any but a momentary change.

7. Its velocity is nearly double that of the accompanying general storm.

8. Numerous thunder and hail storms are an invariable accompaniment.

A few fictions are the following:—

1. Professor Ferrel states on p. 327, "Recent Advances in Meteorology," that in the tornado there is an unstable equilibrium due to "the large vertical gradient of temperature decreasing with increase of altitude."

2. Mr. Finley, in *Science* of Feb. 1, thinks that this same condition must be found, not in the tornado, but in the region just around it.

3. This abnormal decrease of temperature is due to cold air overrunning warm. This is really an impossible condition, since the denser cool air must always under-run that which is lighter and warmer. That a most extraordinary decrease of temperature and most extreme unstable equilibrium, possibly five hundred times as great as can ever occur under natural conditions, does not produce a destructive whirl, advancing scores of miles from its origin, is well shown by the seas of fire extending many square miles in forest clearings. Here there is a temperature at least 1000° higher than that of the air two or three hundred feet above it. There are

occasional whirls set up over such a fire, but they are short-lived, and extend only to its edge.

4. There is a violent uprush of air at the tornado centre. As we have just seen, the tornado is not at the storm-centre, but four hundred miles to the south-east, where there is no rising tendency in the air.

5. There is a uniform flow of northerly upper currents over an extended region, and tornadoes are produced at spots one hundred miles apart by the breaking-through of the warm lower air.

6. The tornado, in its onward motion dipping here and there for one hundred miles and more, has its energy kept up by a continual upsetting of the equilibrium, conveniently occurring just in front of it exactly at the moment of its advance, and nowhere else. These latter certainly have no facts to sustain them, and must be regarded as impossible or highly visionary till observations in the cloud region give still further facts. Until these facts are had, it is unsafe to theorize.

H. A. HAZEN.

Washington, Feb. 4.

A Deadly Gas-Spring in the Yellowstone Park.

THE familiar fable of the upas-tree, living in a valley of death wherein all life was killed by its deadly exhalations and the ground was strewn with the bones of its victims, has been proven, like many a traveller's tale, to be a highly colored and exaggerated account of a natural phenomenon. The upas-tree is now well known to have poisonous sap, but not poisonous vapors. But the story survives in the accounts given of the Death Valley of Java, which it was long believed no traveller could cross, "wherein every living being which penetrated the valley falls down dead, and the soil is covered with the carcasses of tigers, deer, birds, and even the bones of men, all killed by the abundant exhalations of carbonic-acid gas, with which the bottom of the valley is filled." Such is the description given by Lyell¹ of this famous valley; while another locality is described as a place where "the sulphurous exhalations have killed tigers, birds, and innumerable insects, and the soft parts of these animals are perfectly preserved, while the bones are eroded and entirely destroyed. The researches of Junguhn² have shown that these accounts are much exaggerated, the "valley of death" being a funnel-shaped depression but one hundred feet in diameter, instead of a valley half a mile across. In the bottom of this depression there is a hole about fifteen feet in diameter, from which gaseous emanations are given out, which at times accumulate to a depth sufficient to envelop and suffocate animals on the bottom of the hollow. Repeated visits by Junguhn, extending over a period of twelve years, showed that the amount of gas varied greatly from time to time, but rarely ever rose over two feet and a half above the bottom. At the time of his earlier visit, he found the body of a Javanese native in the depression, but experienced no difficulty or oppression while there himself. This same body was still undecomposed, owing to the preservative effect of the layer of gas, when he repeated his visit eighteen months later. The only other remains seen during his subsequent visits were the carcasses of six swine which were decomposed and putrid. At this time the absence of the gas was shown by the presence of a crow feeding upon the dead bodies.

Though thus shorn of much of its former glory, this Pakaraman, or poison-hole, is the largest and most dangerous of the gas-springs or mofettes of Java, and indeed of the world, and really deserves the title of a natural death-trap. Though such emanations are common in all volcanic regions, this has been the only place known where the gases have accumulated, and caused the death of the larger animals.

In the Yellowstone National Park, now so well known as the wonderland of America, there is a place equalling this famous death valley, and where the gaseous exhalations have proved fatal to numerous bear, elk, and many smaller animals.

This place, to which the appropriate name of "Death Gulch" is given, was discovered by the writer during the past summer (1888), while making a geological examination of the region for Mr. Arnold Hague, the geologist in charge of the survey of the park. It is situated in the extreme north-eastern portion of this reservation, a

¹ Principles of Geology, 1878, i. p. 590.

² Java Seine Gestalt, etc., German translation by Hass Karl, ii. p. 202.

short distance south of the mail-route, which, leaving Lamar River, follows up Soda Butte Creek to the mining-camp of Cooke City. In this region the lavas which fill the ancient basin of the park rest upon the flanks of mountains formed of fragmentary volcanic ejecta, the tertiary andesitic breccias, which rest in turn upon nearly horizontal paleozoic strata; while the hydrothermal forces, which are represented by the geysers and hot springs of the central portion of the park, where the lava-sheet is thicker, show but feeble manifestations of their energy in the almost extinct hot-spring areas of Soda Butte, Lamar River, Cache Creek, and Miller Creek. Although hot water no longer flows from the vents of these areas, the deposits of travertine, sinter, and decomposed rock, attest the former presence of thermal springs. Gaseous emanations are now given off, however, in considerable volume, producing extensive alteration in the adjacent rocks, and giving rise to sulphurous deposits.

It is at one of these places that the fatal ravine is found. Situated on Cache Creek, but two miles above its confluence with Lamar River, it is easily reached by a horseback ride of some five miles from the mail station of Soda Butte. The region is, however, rarely visited; for hunting is forbidden in the park, while the place has not been known to present any attraction for the few visitors who pass near it on their way to the well-known Fossil Forests and the weird scenery of the Hoodoo basin.

An old elk-trail, which runs along the north bank of Cache Creek, affords easy travelling, and leads to a little opening in the pine-forest bordering on the stream. In the centre of the meadow is a shallow depression, once the bed of a hot-spring pool, now dry, and covered with an efflorescence of salt, making it attractive to the elk and other game of the region as a "lick." The banks of the creek opposite this meadow and below it are covered with the ancient hot-spring deposits, which are very dense and hard, and at the borders of the stream have been polished by the action of the water until the surface shines like glass. A hot-spring cone half washed away by the creek, and a mound of altered travertine on the opposite bank, show the character of the ancient hot-spring water, the rippled surface of the deposit being exactly like that of the beautiful terraces and slopes of the Mammoth Hot Springs. At present, however, the only thermal action is the emission of a little tepid sulphurous water at the edge of the stream. On the other hand, the gaseous emanations are very striking and abundant.

In the middle of the creek, which here forms a deep pool about thirty feet across, bordered by the polished calcite already mentioned, the water boils up furiously at several places. This water is, however, quite cold; and the "boiling" is caused by the very copious emission of gas, mainly, no doubt, carbonic acid, though containing some sulphuretted hydrogen, since its smell is quite noticeable, and the water is slightly turbid with particles of sulphur, which also coat the sides and bottom of the pool. Rising through the water of the creek, the great amount of gas given off at this place is easily appreciated, but equally copious emanations may occur from the deposits and old vents near by, which, being invisible, remain unnoticed.

Above these deposits of altered and crystalline travertine, the creek cuts into a bank of sulphur and gravel cemented by this material, and a few yards beyond is the debouchure of a small lateral gully coming down from the mountain-side. In its bottom is a small stream of clear and cold water, sour with sulphuric acid, and flowing down a narrow and steep channel cut in beds of dark gray volcanic tuff. Ascending this gulch, the sides, closing together, become very steep slopes of white decomposed rock, the silicious residue formed by the decomposition of the rocks by acid vapors or waters. The only springs now flowing are small oozes of water issuing from the base of these slopes, or from the channel-bed, and forming a thick, creamy, white deposit about the vents, and covering the stream-bed. This deposit consists largely of sulphate of alumina. The slopes show lowland areas where sulphur has been deposited by the oxidation of sulphurous vapors, but no extinct hot-spring vents were found. About one hundred and fifty feet above the main stream, these oozing springs of acid water cease; but the character of the gulch remains the same. The odor of sulphur now becomes stronger, though producing no other effect than a

slight irritation of the lungs. The gulch ends, or rather begins, in a "scoop" or basin about two hundred and fifty feet above Cache Creek; and just below this we found the fresh body of a large bear, a silver-tip grisly, with the remains of a companion in an advanced state of decomposition above him. Near by were the skeletons of four more bears, with the bones of an elk a yard or two above; while in the bottom of the pocket were the fresh remains of several squirrels, rock-hares, and other small animals, besides numerous dead butterflies and insects. The body of the grisly was carefully examined for bullet-holes or other marks of injury, but showed no traces of violence, the only indication being a few drops of blood under the nose. It was evident that he had met his death but a short time before, as the carcass was still perfectly fresh, though offensive enough at the time of a later visit. The remains of a cinnamon bear just above and alongside of this were in an advanced state of decomposition, while the other skeletons were almost denuded of flesh, though the claws and much of the hair remained. It was apparent that these animals, as well as the squirrels and insects, had not met their death by violence, but had been asphyxiated by the irrespirable gas given off in the gulch. The hollows were tested for carbonic-acid gas with lighted tapers without proving its presence; but the strong smell of sulphur, and a choking sensation of the lungs, indicated the presence of noxious gases, while the strong wind prevailing at the time, together with the open nature of the ravine, must have caused a rapid diffusion of the vapors.

This place differs, therefore, very materially from the famous Death Valley of Java and similar places in being simply a V-shaped trench, not over seventy-five feet deep, cut in the mountain-slope, and not a hollow or cave. That the gas at times accumulates in the pocket at the head of the gulch, is, however, proven by the dead squirrels, etc., found on its bottom. It is not probable, however, that the gas ever accumulates here to a considerable depth, owing to the open nature of the place and the fact that the gulch draining it would carry off the gas, which would, from its density, tend to flow down the ravine. This offers an explanation of the death of the bears whose remains occur, not in this basin, but where it narrows to form the ravine; for it is here that the layer of gas would be deepest, and has proven sufficient to suffocate the first bear, who was probably attracted by the remains of the elk, or perhaps of the smaller victims of the invisible gas; and he, in turn, has doubtless served as bait for others who have in turn succumbed. Though the gulch has doubtless served as a death-trap for a very long period of time, these skeletons and bodies must be the remains of only the most recent victims; for the ravine is so narrow and the fall so great, that the channel must be cleared out every few years, if not annually. The change wrought by the water during a single rain-storm, which occurred in the interval between my first and second visits, was so considerable that it seems probable that the floods of early spring, when the snows are melting under the hot sun of this region, must be powerful enough to wash every thing down to the cone of *débris* at the mouth of the gulch.

Gaseous emanations are very frequent in volcanic countries, and may be either temporary or permanent. The former are, as is well known, particularly abundant after volcanic eruptions. The gases emitted from fissures in the flanks of Vesuvius are said to have killed thousands of hares and pheasants, and whole herds of cattle have been suffocated by volcanic gas given off near Quito. The permanent emissions of gas, such as the mofettes of Italy, the Laacher See, and the Auvergne, remain unchanged, however, for centuries. Where carbonic-acid gas is evolved from a fairly uniform surface, it is quickly diffused into the atmosphere upon the slightest movement of the air; but the case is quite different when the gas is emitted in caves or hollows in the ground. In such places it accumulates, because of its density and slow diffusion, until the hollows are filled to the brim, any excess being quickly diffused as from a level surface. Small hollows of this kind occur in the travertine deposits of the Mammoth Hot Springs of the park, and near the Hot Lakes of the Lower Geyser basin. In these places, small birds, mice, etc., attracted by the warmth of the vapors, or the dead insects, are often suffocated by the gases. Such hollows resemble the mofettes of the Laacher See in Germany, where

dead mice and birds are always found, and are common in other regions as well. The well-known Grotto del Cano, near Naples, is the most familiar example of such accumulations of carbonic-acid gas; and visitors are frequently entertained by the asphyxiation of a poor dog, while the guide, whose head rises above the gas, is not affected by it. Death Gulch is, however, without a peer as a natural bear-trap, and may well be added to the list of the wonders of the Yellowstone Park.

WALTER H. WEED.

U. S. Geol. Surv., Washington, Jan. 30.

A New Method for the Microscopical Examination of Water.

In making microscopical¹ examinations of potable waters, it is entirely impracticable, on account of their relative purity, to proceed directly. Repeated examinations of random samples might yield absolutely nothing, although filtration of a few cubic centimetres through a fine cloth might show that in the same water there were abundant microscopic forms.

The importance of being able to ascertain the presence of these microscopic organisms, and to determine their number and species in any given sample of water, is self-evident. It is important, not only from a purely scientific, but also from a sanitary, point of view, to know precisely what is contained in drinking-water. Again: large manufacturing interests are dependent upon the purity of the water supplied to them through filters or otherwise, while many large towns depend upon the efficiency of filters for the purity of their water-supply. A microscopical examination of the water before and after filtration shows very clearly the actual work which the filter accomplishes, in a way that it is impossible for chemical analyses to do. From a scientific and sanitary point of view, microscopical examinations are accordingly of great value both as a means for the study of the organisms themselves, and of the influences of changes in the water upon their growth, life, and death, as well as the counter effects produced upon the water by them. For making such examinations there have been hitherto, so far as I know, but two methods employed. One of these is that proposed by Dr. J. D. McDonald in his "Guide to Microscopical Examination of Water" (J. & A. Churchill, London, 1883). In this method the sample to be examined is put into a tall glass cylinder, at the bottom of which is a watch-glass suspended by a platinum wire. This is allowed to stand for forty-eight hours, in order that the matters held in suspension may settle into the watch-glass at the bottom. The upper water is then siphoned off, and the contents of the watch-glass examined under the microscope.

The other method, the origin of which I do not know, is used at present by the Massachusetts State Board of Health. In this method a given quantity of water is passed through a fine linen or cotton cloth tied to the lower end of a funnel. After the water has passed through it, the cloth is removed, and cautiously reversed over the end of a glass tube, the numerous objects which have been caught upon the cloth being now upon the outside. A slide is then placed under the cloth, and a puff of air blown through the tube. The moisture contained in the cloth collects in a drop, which falls upon the slide, carrying with it theoretically the materials filtered out of the water. The slide is then examined under the microscope, and the organisms obtained counted. Both these methods are open to very serious objections, and are so crude that no fair estimates of the number of organisms contained in a given sample of water can be formed. In the case of the first method, I have found that by no means all of the microscopic organisms settle to the bottom, even when the water is left standing a much longer time than forty-eight hours, as there are many which have about the same specific gravity as water, and consequently do not settle. This source of error becomes greater in proportion as the water to be examined becomes purer. In the case of ordinary drinking-water, the sediment is very inconsiderable, although there are large numbers of organisms held in suspension. Under ordinary circumstances, water left standing in this way gives an excellent opportunity for the organisms present to increase. Especially is this the case with filtered water, where the increase is surprisingly rapid. From this it is plain that the sediment in the watch-glass does not represent what was originally in the water, but only

a small part of that amount plus a part of the increase which has since taken place. In the second method, if the cloth be examined microscopically after presumably all the microscopic organisms have been removed, it will often be found that a very large number are stuck in the meshes of the cloth.

For these two methods I have substituted one which, although far from perfect, gives much better results. I have now been using it for four months in making microscopical examinations of water for the city of Boston.

The new method is as follows. A known quantity of water (I have found 100 cubic centimetres a convenient unit) is put into a funnel in the tube of which is half an inch in depth of sand (24 to 30 grains to the inch). The sand is held in place by a stop made of a roll of brass wire gauze, which gives free passage to the water, while it holds the sand in place. Through this the water is filtered, the sand holding back the microscopic forms. The experiments which I have tried, to test whether all the organisms are removed or not, have proven conclusively the efficiency of the sand in holding back all the microscopic organisms in the water. After all the water has passed through, the stop is removed, and one cubic centimetre of distilled water (the water which has just been filtered will answer as well) is thrown into the funnel by means of a pipette. This washes the sides of the funnel, and carries the sand with it down into a watch-glass which is held underneath to receive it. On falling into the watch-glass, the grains of sand separate and sink to the bottom, leaving the lighter organisms which have been caught between them mostly suspended in the water. By stirring this wash-water a more even distribution of the organisms is obtained, and, if any have been carried to the bottom by the falling sand, they are liberated; so that if the wash-water be poured off, and the sand examined under the microscope, it will be found that there are no more organisms among it than might be expected. Some of the water standing above the sand is immediately transferred to a slide, containing a chamber the capacity of which is one cubic millimetre. All the microscopic organisms contained in this chamber are then counted under the microscope, and from the result the total number of organisms in the original sample is computed. I have found this cubic millimetre surprisingly representative of the whole mass of the wash-water, as far as the numbers go, although, as would naturally be expected, the species vary largely in different samples.

This method, as the first which can fairly be called quantitative, opens up a new field, having wide and practical applications. It is to be hoped that microscopical examinations may hereafter take their proper place alongside of bacteriological and chemical analyses, to which they must form important adjuncts.

A. L. KEAN.

Mass. Inst. Technol., Boston, Feb. 1.

Triple Births in the Human Race.

I WAS much interested in the note published in *Science* of Feb. 8, upon triple births in the human race, and I beg to direct your attention to a curious case to be found among the records of Middleboro [Mass.], in which triple births occurred in two successive generations of the same family.

Elisha Vaughan married Joanna Morton, daughter of John Morton of Middleboro.

Children of Elisha and Joanna Vaughan.

Hinksman b. 1708, Jan. 11.
Mercy	}
Sarah	
Thankful b. 1714, Dec. 1.
Thomas b. 1717, Oct. 25.
Hannah b. 1717, Oct. 25.

Children of Hinksman and Desire Vaughan.

Hannah b. 1733, April 29.
Elisha	}
Abraham	
Ebenezer b. 1737, March 21.
Abigail b. 1737, March 21.

The town and church records in Middleboro comment upon the curious reversal of the sexes in the two generations.

ALEXANDER GRAHAM BELL.

Washington, Feb. 12.

¹ It is convenient to designate by "microscopic" all forms of life visible only by means of the microscope, exclusive of the bacteria.

C. & C. ELECTRIC MOTOR COMPANY.

Electric Motors
FOR
Arc and Incandescent Circuits,
Most Economical Motor
on the Market.
Regulation Perfect.
Motors Designed for all Power
Purposes.

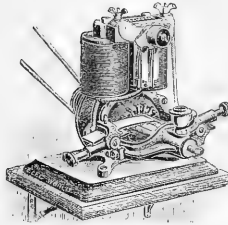

OFFICE and MANUFACTORY:
402 and 404 Greenwich St., New York City.
New England Office, 19 Pearl St., Boston.
Philadelphia Office, 301 Arch St.
Western Office, 139-141 Adams St., Chicago.
Southern Office, 25 Carondelet Street,
NEW ORLEANS.

Publications received at Editor's Office, Jan. 21-26.

- AIRY, O. The English Restoration and Louis XIV., from the Peace of Westphalia to the Peace of Nimwegen. London and New York, Longmans, Green, & Co. 282 p. 24". \$1.
- BARTLETT, J. K. Plans for an Auxiliary Supply of Pure Water under Pressure to the Cities of New York and Brooklyn. New York, McLlroy & Emmet, Pr. 117 p. 4".
- BROWNING, O. An Introduction to the History of Educational Theories. (Reading Circle Library, No. 3.) New York and Chicago, E. L. Kellogg & Co. 237 p. 16". 50 cents.
- BUTLER, N. M. The Argument for Manual Training. Also a Course of Study in Manual Training. (Teachers Manual, No. 11.) New York and Chicago, E. L. Kellogg & Co. 39 p. 24". 15 cents.
- KLEIN, J. F. Elements of Machine Design. Bethlehem, Penn. The Comenitus Pr. 208 p. 8". \$6.
- MODERN Science Essayist. The Popular Evolution Essays and Lectures. Vol. I. No. 1. Herbert Spencer, his Life, Writings, and Philosophy, by D. G. Thompson. Boston, New Ideal Publ. Co. 22 p. 7". 85 per vol., single number, 10 cents.
- PEREZ, B. The First Three Years of Childhood. Tr. by Alice M. Christie. New York and Chicago, E. L. Kellogg & Co. 292 p. 16". \$1.50.
- PERKINS Institution and Massachusetts School for the Blind, Fifty-seventh Annual Report of the Trustees of the, for the Year ending Sept. 30, 1888. Boston, State. 260 p. 8".
- SHAW, E. R., and DONNELL, W. School Devices: A Book of Waxes and Suggestions for Teachers. New York, E. L. Kellogg & Co. 289 p. 16". \$1.25.
- SPENCER, W. B. The Anatomy of Megalocidus Australis (the Giant Earth-Worm of Gippsland). (Trans. Roy. Soc. Victoria, Vol. 1. Part 1.) Melbourne, Stillwell & Co. 60 p. 8".
- TAFT, Royal C., Governor of Rhode Island, Message of, to the General Assembly at its January Session, 1889. Providence, State. 70 p. 8".
- TEMPERANCE Instruction, Scientific, in Schools and Colleges, from December, 1887, to December, 1888. Boston, W. S. Best, Pr. 60 p. 12".
- U. S. BUREAU OF EDUCATION. Report of the Commissioner of the, for the Year 1886-87. Washington, Government. 1170 p. 8".
- U. S. MARINE-HOSPITAL SERVICE, Annual Report of the Supervising Surgeon-General of the, for the Fiscal Year 1888. Washington, Government. 496 p. 8".
- WELCH, A. S. The Teachers' Psychology. New York and Chicago, E. L. Kellogg & Co. 286 p. 12". \$1.25.

A TEMPORARY BINDER

for Science is now ready, and will be mailed postpaid on receipt of price.



Cloth - - - 50 cents.
Half Morocco - 75 cents.

This binder is strong, durable and elegant, has gilt side-title, and allows the opening of the pages perfectly flat. Any number can be taken out or replaced without disturbing the others, and the papers are not mutilated for subsequent permanent binding. Filed in this binder, Science is always convenient for reference.

N. D. C. HODGES,

47 Lafayette Place, New York.

Readers of Science

Corresponding or visiting with Advertisers, will confer a great favor by mentioning this paper.

Schools.

CONNECTICUT, NEW HAVEN.
MRS. CADY'S SCHOOL FOR YOUNG LADIES. Prepares for Smith and Wellesley, and admits to Vassar by Certificate. Circulars. Early application necessary.

VERMONT, BURLINGTON.
VERMONT EPISCOPAL INSTITUTE. Boarding School for Boys. Prepares for College or Business. Military drill. Terms moderate. Fifty-seventh half-year opens September 3, 1888. Send for catalogue. H. H. ROSS, A. M., Principal.

TERRE HAUTE, IND.
ROSE POLYTECHNIC INSTITUTE.—A School of Engineering. Well endowed, well equipped departments of Mechanical and Civil Engineering. Electricity, Chemistry, Drawing. Extensive Shops & Laboratories. Expenses low. For catalogue address T. C. Mendenhall, Pres.

Insurance.

DELAY IS DANGEROUS.

We call attention to the new form of Accident (indemnity) Insurance policies, which are written by the Merchant's Casualty Insurance Association, 27 Park Row, New York City, John S. Purdy, Secretary. These policies cover weekly allowances of from \$10 to \$25, according to occupation, at a cost of only \$6 a year exclusive of the cost to join, which is \$5 payable once only. The public, as a rule, carry life insurance, and the ordinary accident policies issued by companies, paying a sum in case of death, is not so desirable as one of these indemnity policies in case of accidents, which are so plentiful in this fast age with its railroad horrors, fast driving, electric wires and other countless forms of danger to which the public is constantly exposed. The fact of the Association having no unpaid claims, and its having just passed an examination by the Insurance Department of New York State, shows that the management is liberal with its policy-holders and conservative in its action. The Association also desires to secure energetic Agents in every village and town, to whom territory and favorable terms will be given.

Scientific Apparatus.

J. GRUNOW,

621 Sixth Avenue, New York.
Established 1852.

MAKER OF

Microscope Stands,
Oil Immersion Objectives and Abbe Condensers for Bacterial and Histological work, of Objectives, Camera Lucida and other accessory apparatus.

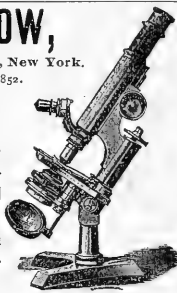

W. H. WALMSLEY & CO.

SUCCESSORS TO

R. & J. BECK,

1016 Chestnut Street Phila

Microscopes and all Accessories and Apparatus. Photographic and Photo-Micrographic Apparatus and Outfits.

Spectacles, Eye Glasses, Opera and Marine Glasses, etc.

Illustrated Price List mailed free to any address. Mention Science in corresponding with us.



ZOOLOGY, ANATOMY, PALEONTOLOGY.—We arrange and furnish collections for educational purposes. We have an immense stock of recent shells and fossils; anatomical preparations; models (papier mache) of the human body, divisible, complete, and in separate parts, also parts of mammals, very important for the study of anatomy; also microscopical preparations. Linnæan Institution for Natural History, Berlin, Germany. Our Agent in the U. S., Mr. HERMAN ROLLE, 33 Ave. A, New York City, will send specimen catalogues free on application.

E. & H. T. ANTHONY & CO.
591 Broadway, N.Y.

Manufacturers and Importers of

PHOTOGRAPHIC INSTRUMENTS,

Apparatus and Supplies of every description. Sole proprietors of the Patent Detective, Fairy, Novel, and Bicycle Cameras, and the

Amateur Outfits in great variety, from \$500 upward.

Send for Catalogue or call and examine. ²⁵ More than 40 years established in this line of business.



MAGIC Stereopticons and the Best Views for Public, Church, Home, and Amateur Scientific Exhibitions. Free of charge. Largest stock. Reduced prices. 24 Years' Practical Experience. Illus. Catalogue Free.

GEO. H. PIERCE,

136 S. Eleventh St., Philadelphia, Pa

IMPROVED OIL LIGHT

MAGIC LANTERNS.

Also Lime and Electric Light Apparatus, and mechanical, plain, and fine colored views.

J. B. COLT & CO., Manufacturers,

NO: 16 BEEKMAN STREET, NEW YORK.

WHITALL'S PLANISPHERES OF THE STARRY HEAVENS name and locate all Planets, Stars, and Constellations visible at any given minute of time. Every one should possess set, \$5.00; Miniature, 30 cents postage paid. Ask stationer, or address Wm. T. Cooper, Manager, 307 Race St., Philadelphia, Pa.

Arnold,
Constable & Co.
"Anderson's"
CELEBRATED
ZEPHYRS.
"Freres Koechlin's"
PRINTED SATEENS.

THE SPRING STYLES of these celebrated fabrics are unusually attractive both in design and coloring.

Broadway & 19th St.

New York.

THE GREAT AMERICAN
TEA COMPANY
GOOD NEWS TO LADIES.
Greatest inducements ever offered. Now's your time to get up orders for our celebrated Teas and Coffees, and secure a beautiful Gold Band or Moss Rose China Tea Set, Diner Set, Gold Band Moss Rose Toilet Set, Watch, Brass Lamp, or Webster's Dictionary. For full particulars address
THE GREAT AMERICAN TEA CO.,
P. O. Box 239, 81 and 83 Vesey St., New York.

Readers of Science

Corresponding with or visiting Advertisers will confer a great favor by mentioning the paper.

Sprague Electric Railway and Motor Company.

For Stationary or Railway Work,
for Mining or Engineering
operations the SPRAGUE MOTORS
are unexcelled.

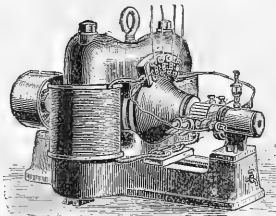

Estimates given for complete
Power Installations.

Send for Circulars and full
Information.

16 and 18 BROAD STREET, NEW YORK.

ELECTRICAL TESTING BUREAU,

Johns Hopkins University, Baltimore, Md.
Resistance Coils and Boxes Compared.
Am meters and Volt meters calibrated.
Condensers standardized.
Primary and Secondary Batteries Tested.
Efficiency of Dynamos and Motors Determined.
Insulation of Cables and Wires Tested.
Etc., Etc.
Circulars describing Methods Used, Prices, Etc., sent on Application.
Address as above.

Inducements in Dress Goods

Previous to the opening of our Spring Novelties we have marked several lines of desirable all-wool fabrics as follows:
3,250 yards plain and striped Beiges, 50cts.; reduced from \$1 per yard.
1,200 yards plain suiting, 6cts.
1,500 yards Herring Bone Stripes at 75 cts., regular price, \$1.25.
1,600 yards invisible Plaids, 85cts. per yard, 54 inches wide; well worth \$1.25.
1,450 yards illuminated Checks, 54 inches wide, at \$1; good value for \$1.50.
Samples of these or any other Dress Goods sent promptly on application.

JAMES McCREERY & CO.

BROADWAY AND ELEVENTH STREET,
NEW YORK.

ENGRAVINGS.

For the largest list ever published of engraved portraits on steel, suitable for illustrators and print collectors, please send for catalogue to
J. C. BUTTRE,
32 Cortlandt St., New York



A Useful and Handsome Present.

Prices Reduced for the Holidays.

The Hulin Pen
Fountain Pen

Warranted 14 karat gold and to give perfect satisfaction—is pronounced by hundreds of pleased customers to be the best fountain pen in the market because it is always ready. Writes freely and never gets out of order.

Sent by mail prepaid for \$1.50, \$3.00 and \$2.50 each, according to size selected.

These are special prices for the holidays, and this offer should be availed of by all who write.

JOHN S. HULIN,
Mfg Stationer and Steam Printer.

Wedding Invitations and Visiting
Cards Engraved to Order.
369 BROADWAY, N. Y.
Near Franklin Street.

The Largest, Handsomest, and Most Complete
Account-Book Manufacturing and Printing Establishment for Fine Commercial Work in New York City.



KIMBALL'S
STRAIGHT CUT
CIGARETTES.

Unsurpassed in quality.
Used by people of refined taste.
Highest awarded at Brussels, 1888.
The finest smoking mixtures are of our manufacture.
Fifteen First Prize Medals.
WM. S. KIMBALL & CO.,
Rochester, N. Y.

R. ELLIS & CO.

BUSINESS, HOTEL AND PATENT BROKERS,

AUCTIONEERS, ETC.

No. 176 BROADWAY,

Room 46.

New York.

CLIENTS Advised free of charge.

TO EMPLOYERS.

Having purchased the fixtures, good will, &c., of the NEW YORK EMPLOYMENT BUREAU, at No. 681 BROADWAY, in this city, we request the patronage of the public in the future. We desire to fill a long-felt want for an employment bureau, where only the best grade of male help is dealt in, and it is our aim to send ONLY such help as is ordered in every instance, and our patrons can rely on us to send strictly first-class help, the references of whom we personally investigate before sending to any one. We simply request a trial, and are convinced that we will give satisfaction in every case. We have on hand help in every branch, which we can send upon receipt of telegram or letter, AND FOR WHICH WE MAKE NO CHARGE TO AN EMPLOYER.

NEW YORK EMPLOYMENT BUREAU,
(AS REORGANIZED).

SCIENCE

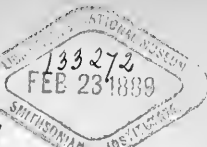

SEVENTH YEAR.
VOL. XIII. No. 316.

NEW YORK, FEBRUARY 22, 1889.

SINGLE COPIES, TEN CENTS.
\$3.50 PER YEAR, IN ADVANCE.

THE CHEQUE BANK LIMITED.

ESTABLISHED IN LONDON, 1873.

CHIEF OFFICE, 4 Waterloo Place, Pall Mall, London.

TRUSTEES:

The Right Honorable JOHN BRIGHT, M.P.

The Right Honorable EARL BEAUCAMP.

Bankers: Bank of England.

The Capital of the Bank and its Guarantee Fund of 599 is invested in Government Securities.

The Bank does not discount Notes or Bills, nor speculate, but loans its Deposits against Government Securities, thus making the Cheque Bank Cheques EQUAL TO CASH—as Bank of England Notes are.

The Cheque Bank issues Cheques singly or in books from ONE POUND upwards, for the use of Travelers, and for others remitting money to Europe, available in every town in England, Scotland, Ireland, and Wales. In every town of Europe, and all other parts of the world, Cheque Bank Cheques are accepted as Cash by all the British Government Offices.

Travelers and others holding Cheque Bank Cheques can have their mail matter addressed to them, care of the Cheque Bank, London, who will take charge of the same and forward to any address.

For Hand-Book containing List of upwards of 2000 of the principal Banking Houses throughout the world which the Cheque Bank uses, and for all information, apply to the AGENCY.

CHEQUE BANK, Limited,

UNITED BANK BUILDING,
2 Wall St., New York.
E. J. Mathews & Co., Agents.

REFERENCES BY PERMISSION:

JNO. W. MACKAY, Esq., President Commercial Cable Company, Mackay-Bennett Cables, New York.

F. O. FRENCH, Esq., President Manhattan Trust Co., New York, and others.

A novel by the Author of "The Story of Margaret Kent."

A DAUGHTER OF EVE.

1 vol., 12mo, \$1.50.

Every one will welcome with enthusiasm a new novel by this most popular and delightful author. A competent critic pronounces it "a book stronger than 'Queen Money' and as clever and charming as 'Margaret Kent.'"

STEADFAST.

By ROSE TERRY COOKE, author of "Somebody's Neighbors," "The Deacon's Week," etc. \$1.50.

"This story is one of Mrs. Cooke's masterpieces. Just at this time, in the excitement of discussion brought about by 'Robert Elsmere' and 'John Ward, Preacher,' I think 'Steadfast,' with its treatment of the old Orthodox question in the old days, backed as it is by history, will come in on the tide of interest, with a new flavor, which must lead on to popularity."—NORA PERRY.

SAFE BUILDING.

By LOUIS DE COPPET BERG. Vol. I. Square 8vo, illustrated, \$5.00.

"The author proposes to furnish to any earnest student the opportunity to acquire, so far as books will teach, the knowledge necessary to erect *safely* any building."

"These papers are the work of a practising architect and not of a mere theorist. In short, these papers are in the highest sense practical and valuable."

LIGHTHOUSES.

Ancient and Modern. By MAJOR D. P. HEAP, U.S.A. Square 8vo. With 100 illustrations. \$5.00.

Indispensable to all Architects and Engineers.

GREAT CAPTAINS.

By COL. THEODORE AYRAULT DODGE, U.S.A. 8vo. With 21 maps. \$2.00.

Sold everywhere. Sent, postpaid, on receipt of price, by the publishers.

TICKNOR & CO., Boston.

JUST OUT:

A LOVE MATCH.

By Ludovic Halévy, the author of 'L'Abbé Constantin,' translated by H. de Veer and V. Foster, and

KING APEPI.

By Victor Cherbuliez, de l'Académie Française.

In one volume, in 12mo, paper, 30 cents.

This is the first volume of a new series entitled "Gleanings from Foreign Authors," and published by

JOHN DELAY,

816 BROADWAY, NEW YORK.

Schools.

CONNECTICUT, NEW HAVEN,

MRS. CADY'S SCHOOL FOR YOUNG LADIES. Prepares for Smith and Wellesley, and admits to Vassar by Certificate. Circulars. Early application necessary.

VERMONT, BURLINGTON.

VERMONT EPISCOPAL INSTITUTE. Boarding School for Boys. Prepares for College or Business-Military drill. Terms moderate. Fifty-seventh hall opens September 3, 1888. Send for catalogue. H. H. ROSS, A.M., Principal.

TERRE HAUTE, IND.

KENTON POLYTECHNIC INSTITUTE.—A School of Mechanical Engineering. Well-endowed, well-equipped departments of Mechanical and Civil Engineering. Electricity, Chemistry, Drawing. Extensive Shops & Laboratories. Expenses low. For catalogue address T. C. Mendenhall, Pres.

LONGMANS, GREEN, & CO.'S NEW BOOKS.

LADY BRASSEY'S LAST JOURNALS. The Last Voyage to India and Australia, in the "Sunbeam." By the late Lady Brassey. With Charts and Maps, and 40 Illustrations in monochrome (20 full-page), and nearly 200 illustrations in the Text from Drawings by R. T. Pritchett. Royal octavo, cloth, \$6.00.

Field and Hedgerow. Being the last Essays of Richard Jefferies. Collected by his Widow. Crown 8vo, \$1.75.

A few copies have been printed on large paper, with an etched portrait of Richard Jefferies. Price throughout, 75 cents.

The Son of a Star: a Romance of the Second Century. By Benjamin Ward Richardson, M.D., F.R.S. Crown 8vo, \$1.50.

"Dr. Richardson has written a most entertaining and at the same time instructive historical romance."—Hartford Courant.

Masks or Faces? A Study in the Psychology of Acting. By William Archer. Crown 8vo, cloth, \$1.75.

Mr. Archer takes up afresh the question debated by M. Coquelin and Mr. Irving as to the amount of feeling an actor should have. He has collected from books and from leading living actors a mass of pertinent and interesting anecdotes. Among those who have helped him are Mary Anderson, Mrs. Kendal, Genevieve Ward, John Drew, and Dion

book, which in its mechanical outfit has a dress worthy of its sterling contents."—N. Y. Nation.

B. C. 1887. A Ramble in British Columbia. By J. A. Lees and W. J. Clutterbuck, authors of "Three in Norway." With map and 16 illustrations from sketches and photographs by the authors. Crown 8vo, ornamental cloth, \$2.25.

Social Progress: an Essay. By Daniel Greenleaf. New and cheaper edition. 8vo, \$2.00.

"An inquiry into the fundamental principles of social ethics and a discussion of the trend of social evolution. Mr. Thompson concludes by declaring the belief that social progress can be attained only through the perfection of social liberty."

Civilization and Progress. By John Beatie Crozier. New and cheaper edition. 8vo, \$2.00.

"The book of a very able man. . . . The testimony which we are compelled to give to the high ability of this ambitious work is completely impartial. . . . Full of original criticism."—Great Hierarchy faculty.

"A book far less superficial than Mr. Buckle's."—Spectator.

An Inquiry into Socialism. By Thomas Kirkup, author of the article on "Socialism" in the "Encyclopaedia Britannica." Crown 8vo, \$1.50.

Practicable Socialism. Essays on Social Reform. By the Rev. and Mrs. A. Barnett. Crown 8vo, 90 cents.

Graphics; or, the Art of Calculation by Drawing Lines, applied especially to Mechanical Engineering. By Robert H. Smith, Professor of Engineering, Mason Science College, Birmingham. Part I. Text, with separate Atlas of Plates—Arithmetic, algebra, Trigonometry, Vector and Locor Addition, Machine Kinematics, and Statics of Flat and Solid Structures. 8vo, \$5.00.

Deductive Logic. By St. George Stock. (Print-

ed at the Clarendon Press.) Fcap, 8vo, \$1.25.

Epochs of Modern History. (New Volume.) Author's edition.

The English Restoration and Louis XIV. 1648-1678. By Osmond Airy. Fcap. 8vo, maps, \$1.00.

* Full list of this series on application.

A Text-Book of Elementary Botany. By R. J. Harvey Gibson, M.A., F.R.S.E., Lecturer on Botany in University College, Liverpool. With 102 Illustrations. Crown 8vo, \$1.75.

Physical Realism: being an Analytical Philosophy from the Physical Objects of Science to the Physical Data of Sense. By Thomas Case, M.A., Fellow and Senior Tutor C. C. Oxford. 8vo, \$5.00.

"A powerful protest against the psychological idealism of Descartes, Locke, and Hume, and a contribution toward the restoration of mental, by a return to natural, philosophy. . . . The book is warmly to be commended on account of the mastery which is displayed of the most wonderful facts in physical science, of the skill with which mental philosophies, ancient and modern, are examined, and of the close and logical reasoning by which the author seeks to establish his hypotheses."—*Scottsman*.

Force and Energy: a Theory of Dynamics. By Grant Allen. 8vo, \$2.50.

"Written with extreme lucidity. . . . We can safely assure our readers that, whatever view they may take, they will find Mr. Allen's book pleasant and profitable reading."—*Engineer*.

Chance and Luck. A Discussion of the Laws of Luck, Coincidences, Wagers, Lotteries, and the Fallacies of Gambling, with Notes on Poker and Martingales. By the late Richard A. Proctor. A new and cheaper edition. Crown 8vo, boards, 75 cents; cloth, 90 cents.

For sale by all Booksellers. Sent on Receipt of price by the Publishers,

GUARANTY INVESTMENT COMPANY

CAPITAL \$250,000.

Hon. ALBERT H. HORTON (Chief Justice, Kansas Supreme Court), Topeka, Kan., Pres't.

7% Guaranteed Farm Mortgages 7%

The Company calls the special attention of Investors to the following points :

- I. All loans guaranteed and interest payable semi-annually at the Importers' & Traders' National Bank, New York.
- II. Unusual fullness of information, not only about the security itself, but about the general development of the section where the farm is located.
- III. An examination each year of the general business of the Company and the Mortgages themselves by a COMMITTEE OF INVESTORS sent for the purpose.
- IV. Many hundred Mortgages taken and NOT A SINGLE FORECLOSURE.
- V. Exhibitions in New York at frequent intervals, of Kansas and Nebraska Farm Products. The Exhibition at the American Institute in the fall of 1888, received the *HIGHEST AWARD* of superiority.
- VI. Monthly Bulletins giving full information about all Mortgages offered for sale.

Address for Monthly Bulletin and Investors' Committee Report for 1888,

HENRY A. RILEY, General Eastern Manager, 191 Broadway, N.Y.

16 PAGES. **THREE** 16 PAGES.

Hundred Thousand new subscribers for *The Family Journal and Ladies' Companion* wanted. It is the most interesting and instructive paper ever issued. Subscribers will receive during the coming twelve

MONTHS

novels written by American Authors, complete in each three numbers. The story of popular works of fiction will be retold by a novel reader, the most interesting and unique feature ever introduced in any publication, giving the substance of popular and standard books by famous writers in a space easily read by the busiest people. We have engaged

FOR

this work a widely known and popular writer. Comments on Current Events, Fashions, New and Original Ideas and Designs for Ladies' Fancy Work and Household Decoration, Letters from Correspondents and their Answers. The colleges and seminaries of the United States will be treated one each month in an illustrated article, showing the particular advantage of each, cost of attendance, etc. Invaluable to parents having sons or daughters whom they desire should receive the advantages of a higher education than the ordinary school affords. Articles on Painting and Drawing, giving home instruction by a well-known artist. A trial subscription of this elegant paper will be sent to any address, three months, for

TEN CENTS.

Liberal pay for literary work adapted to our columns and for new and original drawings, designs and ideas on any subject which we can use.

Premium List the most complete in the world. We offer inducements to club raisers and agents approached by no other publishing house. The celebrated Gilbert Out Waist Linings, which we send post paid to any one sending us two yearly subscribers at 50 cents each is alone worth 75 cents. Sent to any address, postpaid one year, 50 cents; six months, 25 cents, and a three months' trial subscription for only 10 cents.

TRY IT! TRY IT! TRY IT!

and you will become a permanent reader. Address:

John L. Douglass, Publisher,
322 Broadway, N. Y.

Readers of Science

Corresponding or visiting with Advertisers, will confer a great favor by mentioning this paper.

KNABE

PIANOFORTES.

UNEQUALLED IN

Tone, Touch, Workmanship and Durability.

WILLIAM KNABE & CO.

NEW YORK : No. 112 Fifth Av., above 16th St.
BALTIMORE : Nos. 22 and 24 E. Baltimore St.
WASHINGTON : No. 817 Market Space, Penn. Av., near 9th St.

SCHOOLS AND COLLEGES

will have a positive advantage by ordering their furniture apparatus and supplies from
C. PARDO & CO.,
31 East 17th St., New York.

Wants.

WANTED.—A teacher for the Natural Sciences and History, who is also competent for the position of Associate Principal, in a flourishing private school. Address P. O. Box 385, Plainfield, N. J.

ON SALARY AND COMMISSION A CANVASSER for Subscriptions to *Science*.

Old and Rare Books.

A. S. CLARK, Bookseller,

34 PARK ROW, NEW YORK CITY.

A Gleaner in the By-ways of Literature. Results of Gleaning found in Catalogues issued from time to time.

CATALOGUE NO. 27 NOW READY.

BACK NUMBERS and complete sets of leading Magazines, Rates low. AM. MAG. EXCHANGE, Schoharie, N. Y.

H. WILLIAMS,

Dealer in Old Magazines, Reviews, &c. Scientific periodicals a specialty. 39 Macdougall St., N. Y.

FOOD ADULTERATION

And its Detection. With photomicrographic plates and a bibliographical appendix. By J. P. Battershall. 328 pages. 8vo, cloth. Price, \$3.50. Circulars and Catalogues on application. E. & F. N. SPON,

12 Cortlandt St., New York.

WHY YOU SHOULD USE

Scott's Emulsion

of **Cod Liver Oil** WITH
HYPOPHOSPHITES.

It is used and endorsed by Physicians because it is the best.

It is Palatable as Milk.

It is three times as efficacious as plain Cod Liver Oil.

It is far superior to all other so-called Emulsions.

It is a perfect Emulsion, does not separate or change.

It is wonderful as a flesh producer.

It is the best remedy for Consumption, Scrofula, Bronchitis, Wasting Diseases, Chronic Coughs and Colds.

Sold by all Druggists.

SCOTT & BOWNE, Chemists, N. Y.

SCIENCE

FRIDAY, FEBRUARY 22, 1889.

PRACTICAL ELECTRIC-RAILWAY PROPULSION.

It is a striking indication of the overcrowded surcharged state of modern life that events of extreme significance and momentous importance take place without exciting more than a ripple on the surface of its current, so rapid, deep, and vast it is.

Such an instance is depicted in the accompanying illustration, which is of the electric locomotor "Benjamin Franklin," with its eight-car train, now running upon the Ninth Avenue Elevated Railway in New York City.

With these perfectly intelligible and merely fortuitous differences, the service of the steam and electric train is identical.

What the "Franklin" has achieved in its experimental work may be briefly stated as follows: It has drawn eight empty cars—making, with the locomotor, 122 tons in train—up a gradient of nearly two per cent at 7½ miles per hour, developing, in so doing, over 120 horse-power; it has taken four cars up the same gradient, with the average load of passengers, or 70 tons in train, at 15½ miles per hour, more than two miles faster than the schedule speed of the steam-locomotives; it has maintained speed of 30 and 25 miles per hour with trains of two and three unloaded cars.

All this has been done without the slightest accident or delay of

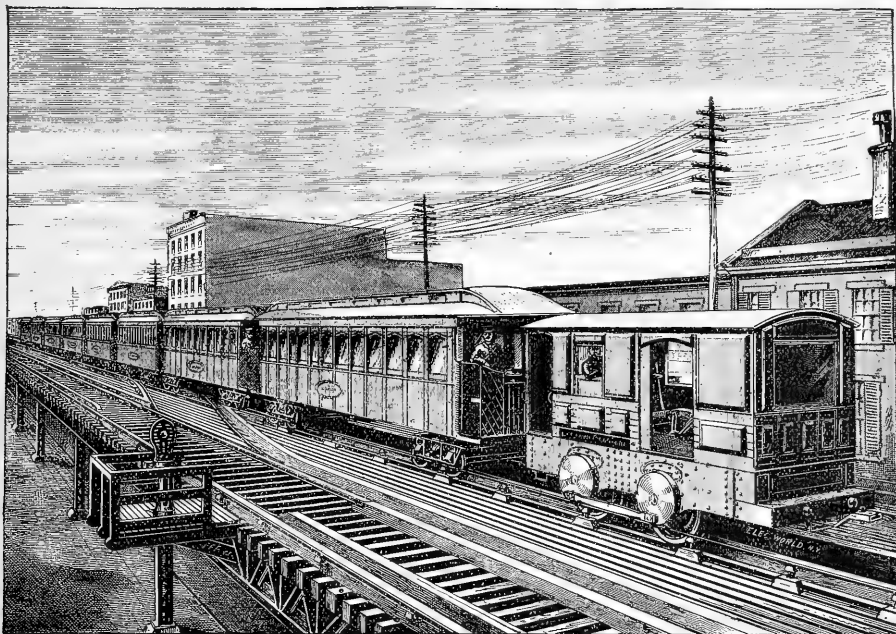

DAFT ELECTRIC MOTOR AND TRAIN OF EIGHT CARS ON THE NEW YORK ELEVATED RAILWAY.

To be literally accurate, it should be said that the service is confined to certain hours of the day, that only three or four cars are used in it, and that passengers are only taken on at the termini; viz., Fourteenth and Fiftieth Street stations.

The reasons for these limitations are as follows: Since the locomotor has to be switched from one end of the train to the other at each terminus, only that portion of the day is available in which the headway of the steam-trains, among which it runs, affords sufficient time for the operation. In the many hundred miles that the "Franklin" has made, it has never delayed a steam-train or deranged their succession. The cause of not stopping at intermediate stations is, that, as the locomotor has at present no means of utilizing the air-brakes,—though this lack is being provided for,—the necessary reduction of speed near every station, to permit of the trains being brought to rest by hand-brakes, would so trench upon the time needed for switching, at each terminus, as to endanger delaying steam-trains, or sacrificing trips to avoid so doing.

any kind, and with every indication of the locomotor still being well within its ultimate capacity. For facility, certainty, and promptness of manipulation, nothing more could be asked for.

Such a chapter of success as this, quite apart from its technical and commercial significance, ought surely to have been fittingly recognized. The first grand scale electric locomotor in the world's history, and the first ever brought into direct competition with steam-locomotives, after doing all that they do, and triumphantly complying with every imposed condition, elicits little more from the technical press than a few perfunctory allusions alike distinguished for incompleteness and inaccuracy.

The gist of one notice was dissatisfaction that the "Franklin," in spite of its complete success, was not something else than what it is, and an inane caution, that, notwithstanding its ready disposal of every suggested test, and easy rivalling of the steam-locomotives in all respects, it would be advisable to lay this practical, actual entity on the shelf, and wait for the possibility of something better turning

up, in shape of the inchoate *eidolon-fori* of some nameless dreamy inventor.

Technical journalism, in the field of electrical power at least, would seem to be at a low ebb in New York.

As for the current-generating plant and conductive system, they, as well as the "Franklin," are entirely of the Daft design. The former is on Fifteenth Street, about midway between Sixth and Seventh Avenues, and wires of suitable size convey the current to and fro between the stationary plant and the track-conductors. A steam-engine of 250 horse-power drives four dynamo-generators of 50 horse-power each.

The conductor is a copper rod, five-eighths of an inch in diameter, sustained by insulators attached to the guard-timbers alongside the track. Elastic copper "brushes" pressing against and sliding along this rod convey the current to the electro-motive mechanism, which it traverses, causing revolution by its passage, and completes its circuit through the wheels and track-rails.

Time and space will not admit of an analysis of the inherent and incidental economy of electric propulsion; but "he who runs may read," whether or no the preference lies with the light, comparatively noiseless, cleanly electro-locomotor, devoid of steam, smoke, cinder, and hot *jets d'eau*, or the ponderous, clamorous, steam-locomotive, wasteful of fuel, destructive of road-bed, and inherently hampered by nuisances from which its electric rival is absolutely free.

X.

THE WORTHINGTON INDEPENDENT CONDENSER.

THAT the practical results attained by condensing-engines should approximate to those that theory indicates, it is important that the condensing-apparatus employed should be the most efficient possible; that it should maintain the highest vacuum, with the least cost of production; that it should be regular and reliable in action, and simple in construction; and that its application to the engine should be unaccompanied by any risk of accident. These exacting requirements, it is claimed, are fully met by the condenser shown in the accompanying illustrations.

Exhaust-steam from an engine enters a vacuum with a velocity of about 1,900 feet per second; and water, under atmospheric pressure, with a velocity of 47 feet a second. Excepting the machine herein described, it may be said that in all forms of jet-condensers operated by air-pumps, the injection-water and the water from the steam fall to the bottom of the condensing-chamber, come to a standstill before entering the pump, and consequently lose the valuable momentum acquired when entering the vacuum space. In this condenser, however, the construction and arrangement are such that the momentum of the steam and water is conserved, and this force is utilized to assist the pump in its work.

By a careful adaptation of the injector principle, it is possible, in an experimental way, to produce a vacuum, of low degree however, without the use of a pump at all,—simply by the momentum given to a flow of water by the impact of the exhaust-steam at the point of condensation. A condenser dependent upon this alone is not practical, because of its small range of action, the inferior vacuum it obtains, and the low temperature of the discharge-water. A change of the amount of steam to be condensed disturbs the theoretical conditions, and renders this kind of apparatus too unreliable in practice. It is plain that the addition of a duplex pump to the discharge of such an ejector condenser perfects and governs its action. As the momentum of the water is not impaired, the highest economy of operation is reached.

In this condenser, the air set free by the condensation of the steam is intermingled with the water. The pump has the same regularity of motion that is characteristic of Worthington pumping machinery; in fact, it acts as a water-pump, although the water is aerated. There is here a great distinction between this condenser pumping aerated water, and an air-pump pumping air and water unmingled. In the latter case, the air-pump has a varying and irregular duty to perform, and the inevitable result is an irregular and slamming movement.

The lower of the accompanying illustrations is a longitudinal section of one side of the condenser-pump, and also a section of the condenser-cone, spray-pipe, exhaust-elbow, and injection-elbow,

A is the vapor-opening, to which is connected the pipe that conducts to the apparatus the steam or vapor that is to be condensed, and in which a vacuum is to be made and maintained. The injection-water used to produce the condensation of the steam or vapor is conveyed by a proper pipe attached to the injection-opening at *B*. *C* is the spray-pipe, and has at its lower extremity a number of vertical slits, through which the water of injection passes, and becomes spread out into thin sheets. The spray-cone *D*, by means of its serrated surface, breaks the water passing over it into fine spray, and thus insures a rapid and thorough intermixture with the steam. This spray-cone is adjustable by means of the handle *E*. The piston-pump *G* is of the well-known Worthington type; built, however, with especial attention to the requirements of the service which is now being considered. *HH* shows the position of the induction, and *II* of the education valves. *J* is the discharge-opening. At *K* may be seen the steam or engine end of the machine, the standard form used on all Worthington steam-pumps. The steam-valve is an ordinary slide-valve, working upon a flat surface over ports or openings. The motion of this valve is produced by a vibrating arm, *L*, which swings through the whole length of the stroke with long and easy leverage.

This valve motion is a prominent feature of the Worthington independent condenser. To it is due the complete exemption from noise or concussive action. The two pumps are placed side by side, and so combined as to act reciprocally upon the steam-valves of each other. One piston acts to give steam to the other, after which it finishes its own stroke and waits for its valve to be acted upon before it can renew its motion. This pause allows all the water-valves to seat quietly, and removes every thing like harshness of motion.

As one or the other of the steam-valves must always be open, there can be no dead point. The pump is therefore always ready to start when steam is admitted, and is managed by the simple opening and shutting of the throttle-valve.

The operation of the condensing-apparatus is as follows: Steam being admitted to the cylinders *K*, so as to set the pump in motion, a vacuum is formed in the condenser, the engine-cylinder, the connecting exhaust-pipe, and the injection-pipe. This causes the injection-water to enter through the injection-pipe attached at *B*, and spray-pipe *C*, into the condenser-cone *F*. The main engine being then started, the exhaust-steam enters through the exhaust-pipe at *A*, and, coming into contact with the cold water, is rapidly condensed. The velocity of the steam is communicated to the water, and the whole passes through the cone *F* into the pump *G* at a high velocity, carrying with it, in a thoroughly commingled condition, all the air or uncondensable vapor which enters the condenser with the steam. The mingled air and water are discharged by the pump through the valves and pipe at *J*, before sufficient time or space has been allowed for separation to occur.

It will be seen that the zone in which the condensation takes place is small, and the rapid effect is due only to the immense surface exposed by the spraying water. In case the water accumulates in the condenser-cone *F*, either by reason of an increased supply or by a sluggishness or even stoppage of the pump, as soon as the level of the water reaches the spray-pipe and the spray becomes submerged, the vast surface is reduced to a minimum, only a small annular ring being exposed to the steam from the main engine. The vacuum is immediately broken, and the exhaust-steam escapes by blowing through the injection-pipe and through the valves of the pump, and out the discharge-pipe at *J*, forcing the water ahead of it: consequently flooding does not occur.

These condensers have been constructed from those of a very small size up to those of enormous power. Two, which are probably the largest independent condensers in the world, are now applied to an engine of 8,000 horse-power, the injection-water of which amounts to 15,000 gallons a minute, or what is equivalent to about 20,000,000 gallons a day. Many of them are in use in connection with stationary steam-engines, and with marine engines on boats running in fresh water. The Worthington condenser is also used in connection with surface condensers on sea-going steamers, where it has a field of usefulness that is at once apparent to those who will but consider its functions. It performs the duty of two distinct pumps,—the air-pump and the circulating pump. It

produces a high vacuum, and causes a forced or positive movement of the cooling-water. By its use, derangement of the surface-condenser does not deprive the engine of the vacuum, as the inde-

pendent condenser, were located indiscriminately. The boilers and engines were not the most economical, but answered well for a time. Those companies that were fortunate enough to find themselves adjacent to water-supply, when they began to look around for better results, have not waited long to avail themselves of the increased output, or the corresponding saving in fuel, that is to be had by changing the engines from non-condensing to condensing.

Being perfectly adapted to high speed dynamo-engines, many electric light and power companies have found this independent condenser exceedingly valuable in connection with their steam-power. Twenty-five per cent saving in steam-consumption, and hence in the fuel burned, is frequently obtained. The increase in power often exceeds thirty per cent. In one of the above cases the

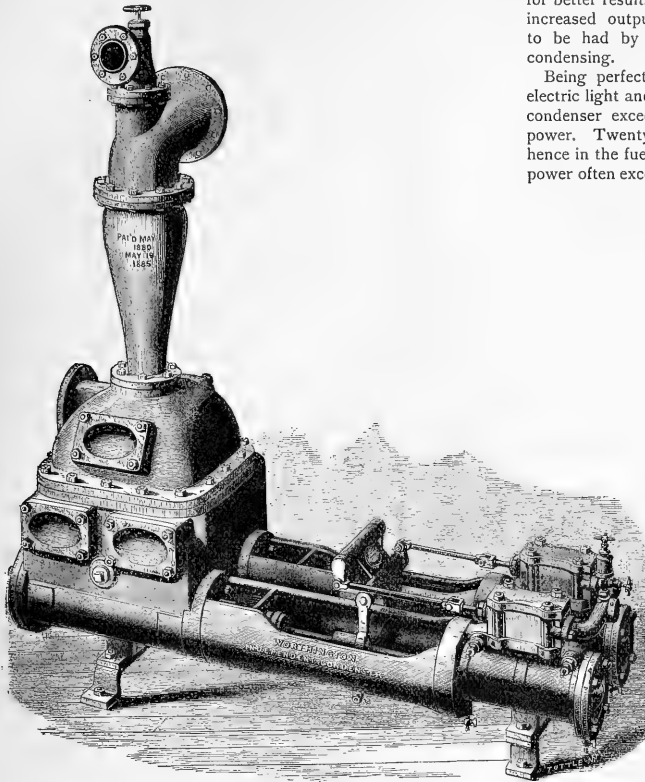

THE WORTHINGTON INDEPENDENT CONDENSER.

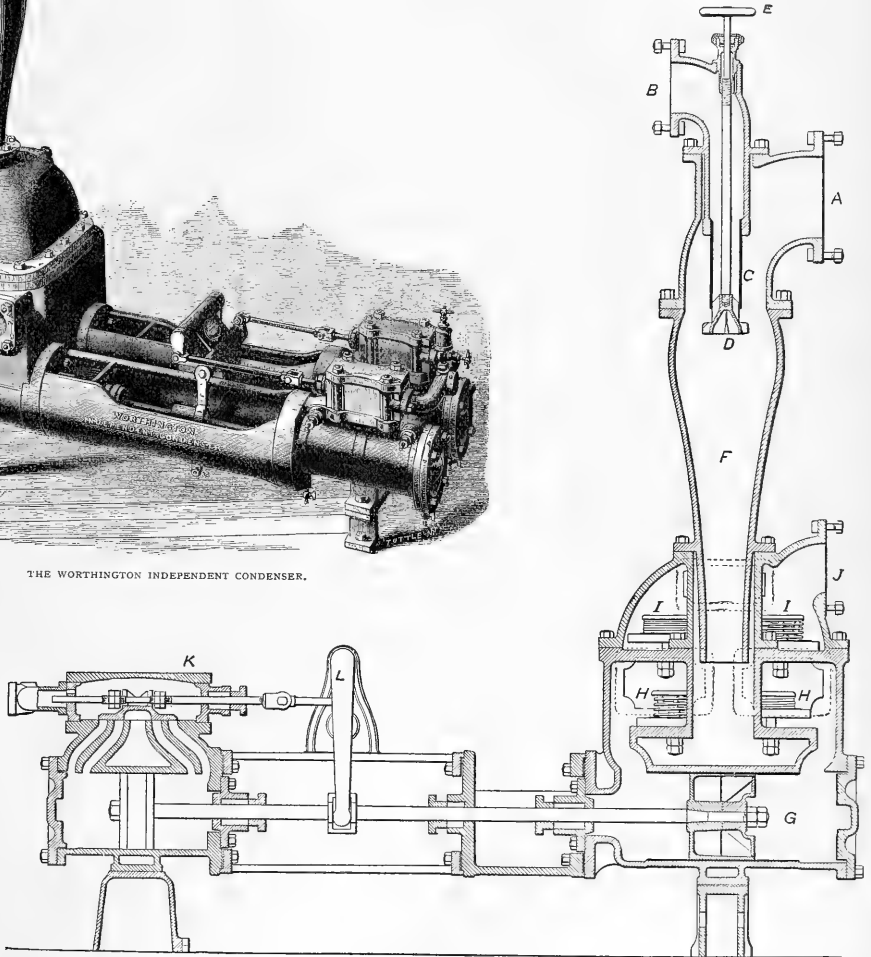

SECTIONAL VIEW OF THE WORTHINGTON INDEPENDENT CONDENSER.

pendent condenser can be used as a jet-condenser for the time being. The fact that one pump is dispensed with, should, in itself, commend the arrangement to the attention of engineers.

It is also a valuable adjunct to electric-lighting plants. Many of the plants that were erected during the early period of the history

gain is used to save steam, and in another to increase the output of power with same consumption of steam, and hence same fuel burned. There is a medium between these methods, and fuel can be saved and also power gained up to a sum total equal to the value of the twelve pounds per square inch made available by the

vacuum. The independent condenser is also used in connection with fire-pumps, mine-pumps, and water-works pumping-engines, as well as with vacuum pans and other evaporating apparatus. They are made by Henry R. Worthington of this city.

THE DEVELOPMENT OF THE POTTERY INDUSTRY OF THE UNITED STATES.

MR. WILLIAM C. DAY, in the recent issue of the "Report on the Mineral Resources of the United States," traces the history of the pottery industry, which has of late become of considerable importance.

The first pottery established in the United States was in New York City, in its earliest days, when under Dutch rule. It was situated near the North River, above the present Chambers Street, the locality being at that time well out of town, in the country. More than a century ago, perhaps, a small pottery was established in Trenton, N.J., by some Frenchmen. Here porcelain, similar to what is now known as French china, was made, and it is said that the goods were very creditable. This establishment existed for some years, but it attained no great importance. At Philadelphia there was a similar pottery venture, also making porcelain or china wares, which are well spoken of for quality. This enterprise was sustained for a number of years, but failed to reach a permanent existence.

There were other attempts to establish potteries in various parts of the country from time to time, and the only one which seems to have given the greatest concern to English manufacturers was one established in South Carolina. This was contemporary with the great Josiah Wedgwood, who has been called the father of the pottery industry in Great Britain, from the fact that he made great improvements in the quality of earthenware, which gave a very great impetus to the business in England. This South Carolina pottery proved quite alarming to Wedgwood, as he feared that it might become a dangerous competitor in supplying the earthenware markets of the colonies: he therefore petitioned Parliament that the manufacture of such goods be prohibited. He seemed to think, that, with the excellent materials found in South Carolina for making earthenware, the industry would become a successful one. His fears, however, proved groundless, as the unequal struggle was of short duration.

One or two pottery enterprises, inaugurated within the past forty years, making special articles of white crockery-ware rather than a general assortment, maintained their existence only, and cannot be termed successful.

The term "pottery industry," as understood at the present time, does not include the many little potteries scattered all over the United States, making stone-ware jugs, pie-plates, drain tile, yellow crockery, etc., and which employ from six to twenty men each. These little establishments made the cheapest and commonest class of pottery products, with which foreign competition was powerless. Owing to the very low-priced class of such wares, the expenses of their importation bore so large a proportion to their cost at the foreign potteries, that competition was out of the question. In fact, in many cases the crates in which the goods were packed, and the inland transportation charges, equalled the original cost of the goods themselves. The pottery industry, as now spoken of, had therefore practically no existence in the United States in 1861, the several hundreds of so-called potteries in this country which statistics show then existed being all of the class above referred to. The Morrill Tariff Bill, and the increase of duty from 24 to 35 per cent, and the subsequent increase to 40 per cent, did not act as inducements towards the establishment of any new enterprise. In 1863 the rapidly increasing premium on gold offered the necessary inducement, and several pottery enterprises were inaugurated. These manufactured at first the commonest class of crockery-ware for domestic uses; but as experience gave confidence, and the wares gradually found favor, better grades were made, until the standard of the china-ware used by the millions of American citizens, and manufactured in this country, is recognized as equal to that made anywhere. It is true that there are several potteries in the United States who make more or less of very fine art

pieces, which are forcing recognition on account of their superior excellence; but the stability of the pottery industry rests upon the fact that it supplies the wants of the people for fine and common crockery for domestic uses, of which we in this country manufacture about 60 per cent. The American potter does not claim to be the peer of his foreign competitor in art productions, but he does claim to equal any foreign manufacturer in the class of china which he produces for the American people. To-day the English potter is copying American shapes, designs, and styles of decorations. How different is this state of affairs from that which existed a few years ago, when the American potter depended upon foreign ideas for his shapes and designs! With the development of the manufacturing process, talent for designing shapes and patterns or styles of decoration has likewise progressed, until we have made our own American shapes and designs, which foreigners have been compelled to copy and adopt in order to find a market for their wares in the United States.

This country still takes about 40 per cent of the total crockery-ware exported by England. This is about the proportion that has been maintained for many years, thus showing that the American potter has increased his output in keeping with the increased consumption of the country.

In regard to the present prices of pottery, it may be said that the consumer can now obtain for two dollars and a half what in 1861 would have cost four dollars.

The pottery industry gives direct employment to about ten thousand people, to whom wages amounting annually to four million dollars are paid; this amount being nearly 50 per cent of the total value of the output of the potteries. In addition to these, there are many thousand more employed in the preparation of the materials for the potter's use, such as mining the clays, quartz, and felspar, and grinding and washing the materials. To these people nearly as much more in wages is paid; in fact, a careful estimate shows that 90 per cent of the cost of manufacturing pottery is paid for labor in one form or another.

The decorating branch of this industry is one of its most interesting features, and one in which great advances have been made in late years. It gives employment of a light, interesting, and elevating character to many young people, both male and female. The growth of this branch has been wonderful, and has made the demand for beautiful decoration, both simple and elaborate, very general, and far more wide-spread throughout the country than ever before. Formerly beautiful decoration was to be found only in costly French and English wares, and the consumption was consequently limited to the wealthiest classes: now beautiful decorated wares are found in almost any household, where they have been obtained at prices which would have been considered impossible a few years ago, and which have reduced very greatly the cost for French and English decorated products, and to a very great extent have enabled American decorated ware to supersede the foreign.

HEALTH MATTERS.

YELLOW-FEVER. — Dr. George M. Sternberg, U.S.A., has been relieved from duty at Baltimore, and is, by direction of the President, in pursuance of the authority contained in the provisions of the Act of Congress approved March 3, 1887, "making appropriations for sundry civil expenses of the government," etc., relating to the methods of preventing the spread of epidemic diseases, to proceed to the Island of Cuba for the purpose named in the letter of the President addressed to the secretary of war, April 17, 1888, and upon completion of this duty to return to his proper station and submit his report to the President. Dr. Sternberg is at the present time at the Hoagland Laboratory, Brooklyn, of which he is general director, engaged in making his preparations for his proposed trip to Cuba to pursue his investigation in yellow-fever. He expects to leave for Havana during the latter part of March.

LEGAL REGULATION OF MEDICAL PRACTICE. — The laws of West Virginia require that every physician in that State must have a certificate from the State Board of Health to entitle him to prac-

tise. An irregular practitioner attempted to evade this legal requirement, and was prosecuted. The case, being decided adverse to him, was finally carried to the Supreme Court of the United States on the ground that the act was invalid. This court sustained the lower courts in the following opinion: "The power of the State to provide for the general welfare of its people authorizes it to prescribe all such regulations as may be necessary to secure the people against the consequences of ignorance and incapacity as well as deception and fraud. One means to secure this end is the method adopted by the State of West Virginia. If the means adopted are appropriate to the calling or profession, and obtainable by reasonable study and application, no objection to their validity can be raised."

CONTAGIOUSNESS OF CONSUMPTION.—Mr. MacMullen, in the *Australasian Medical Gazette*, calls attention to the danger to which healthy travellers are subjected by consumptives. To illustrate this danger, he narrates a case in which a healthy man, on the voyage from London to Australia, was placed in the same stateroom with a consumptive in search of health. Now that consumption is regarded as a communicable disease, there is no longer excuse for this commingling of well and sick in such confined quarters as a ship's stateroom. Steps should be taken by the owners of steamships and other vessels to separate those who are so unfortunate as to have consumption, from those that are healthy, to the degree, at least, that the unsuspecting traveller would not be required to breathe the air impoverished and possibly infected by an invalid suffering from pulmonary consumption.

DOCTORS ADVERTISING.—The Board of Health of Illinois a few months ago revoked the license of H. G. Wildman, a physician, the chief charge being that he had overstepped the ethics of the profession by advertising his success and skill in newspapers. Dr. Wildman then appealed the case to Gov. Oglesby, and he rendered his opinion a few days since, reversing the decision of the Board of Health, and claiming that a physician should not be debarred from practice because he advertises what he can do and has done. Dr. Wildman expends over forty thousand dollars yearly in advertising in papers all over the Union, and several of the Illinois papers went on his bond in the action.

PUBLIC MEDICAL LIBRARIES.—In the proceedings at the reception given to Dr. Oliver Wendell Holmes, says the *New York Medical Record*, on the occasion of his presenting his library to the Boston Medical Library Association, Dr. R. M. Hodges, president of the association, gave some facts regarding the public medical libraries of this country. "First," he said, "in point of time, is the library of the Pennsylvania Hospital, founded in 1760; second, that of the College of Physicians in Philadelphia, founded in 1788; third, the New York Hospital Library, in 1796, etc. Of course, the library of the surgeon-general's office has surpassed in size all these, having a large annual appropriation and a magnificent librarian. Next in rank comes the library of the College of Physicians; next, that of the Academy of Physicians; and our library comes fourth in rank. After that come the Medical Department of the Public Library of Boston, and the New York Hospital Library. In other words, although the youngest of these seven libraries, ours has already passed three of them. We have nearly twenty thousand volumes."

DANGER IN THE POSTAGE-STAMP.—The *Sanitary News* calls attention to the fact that a postage-stamp may in various ways convey contagion. One of the simplest and most plausible is that in which a postage-stamp, partially attached to a letter to pay return postage, is sent by a person infected with some disease to another person. The disease is transferred, in the first place, to the adhesive stamp through the saliva, and in being attached to the letter by the receiver the poison may be transmitted to him in turn through the saliva. Another cause may be the infection of the stamp with disease germs. The stamp, having been exposed in a room where a diseased person lies, may become slightly moistened, and thus retain the germ. That this is true can be proved very simply by a microscopical examination. We often see a person holding change for a moment in the mouth, probably not knowing that investigation has shown that disease germs can be carried by

money. If one could see through what hands the money has passed, he would hesitate before using such a third hand. Silver money is as bad as paper money; but, while many would hesitate to hold a dirty bank-note in their mouth, they think that a silver piece, because bright, is apparently clean.

SANITARY PLUMBING.—In speaking of the effects of sanitary plumbing, the *Sanitary News* says, "Dr. A. R. Carter, of the health department of Baltimore, has published some interesting statistics in regard to the effects of sanitary plumbing. He says that during a period of fifty-four years, from 1830 to 1883 inclusive, there were in that city 12,197 deaths from scarlet-fever, being an average of 226. In the last of those years there were 334 deaths. But the city council then passed an ordinance regulating plumbing, and in the years since, there has been a remarkable decrease in the mortality from scarlet-fever. In 1884 there were 104 deaths; in 1885, 67; in 1886, 32; and in 1887, 36; making a yearly average of 60, but with a plain tendency to decrease. The yearly average of deaths from diphtheria has in the same way diminished from 469 to 234." This kind of reasoning is, in our judgment, very fallacious. If the diminution of diphtheria in Baltimore is to be attributed solely to the improvement in plumbing, why did not the same result take place in New York and Brooklyn, where the improvement in plumbing has been most marked since 1882? In that year in New York there were 1,009 deaths from diphtheria; in 1884, 1,090; 1885, 1,325; 1886, 1,727; 1887, 2,167. In Brooklyn in 1883, 409 deaths occurred from this disease; in 1884, 385; 1885, 519; 1886, 782; and in 1888, 984. So far as scarlet-fever is concerned, the statistics of Brooklyn show no such marked difference in the various years as could be attributed to the plumbing. Thus in 1883 there were 505 deaths from this disease; in 1884, 218; 1885, 363; 1886, 340; and in 1888, 475. In New York there was a notable decline from 2,066 deaths in 1882, to 744 in 1883, which could not be attributed to improvements in plumbing. Since that time the number of deaths has not been as high, but the diminution cannot, we think, be traced to the better plumbing. We do not wish to be understood as disbelieving in the value to life and health of good plumbing,—on the contrary, we regard it as one of the most important factors in the preservation of health,—but we do not think it the only factor, and believe it to be a mistake to attribute the reduction of contagious disease in any small series of years to a single cause.

ELECTRICAL NEWS.

Hertz's Researches on Electric Oscillations.¹

AFTER proving the existence of displacement currents in dielectrics, Hertz turned his attention to the propagation of waves in wires. To investigate this phenomenon, he used the apparatus shown in Fig. 9 (Fig. 11 in article). Here the primary circuit consisted of the two brass plates *AA'*, connected by a conducting wire in which was an air-space. The secondary used was either *B* or *C*, a rectangle and circle of wire respectively, the periods of which were equal to that of the primary circuit,—about .00000014 of a second. The conducting plate *P* was placed behind and close to *A*, and a wire was taken from it in the direction shown, passed through a window, and at a distance of 60 metres was buried in the ground. Now, when the induction-coil is working, and oscillations occur in the primary circuit, disturbances are caused in the circuit *Pnn*, because of the induction of *A* upon *P*; and the period of this disturbance is of course equal to that of the primary. If the wire *mn* were short, there would be danger of disturbances from reflected waves, but 60 metres was found to be a sufficient length to obviate this.

When electrical waves pass through the wire, we should find loops and nodes, as in any other form of oscillation. To test this, secondary circuits whose periods were approximately that of the primary were brought close to the wire, and were moved along it, the result being noticed at different distances. As the secondary passed along, points of maximum and minimum effect were observed at regular intervals. The results are interesting. In the first place, the distances of minimum effect were —0.2 metres,

¹ Continued from No. 314.

2.3 metres, 5.1 metres, and 8 metres; and in another experiment, —.1 metres, 2.8 metres, and 5.5 metres. The half wave-length, then, cannot be far from 2.8 metres, which would give, taking the period as .00000014 of a second, a velocity of propagation of 200,000 kilometres a second,—a result which lies between Fizeau and Gougnelle's values of 100,000 kilometres for iron and 180,000 kilometres for copper, and Siemens's results, which gave from 200,000 to 260,000 kilometres per second for the velocity in iron wire. Another important point is, that, if the copper wire be replaced by one of different metal, the nodal points remain fixed,—that is, the velocity does not change,—and the same is true when the diameter of the wire is changed. This result is striking,

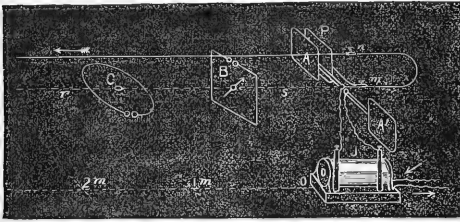

FIG. 9.

especially as showing that at such short periods the magnetic properties of iron wire have very little effect on the phenomenon.

Now, it is evident that a secondary circuit, such as *B*, Fig. 9 (Fig. 11 in paper), is subjected to two actions,—the action of the current in *mm*, and the direct action of the primary. If we obtain for any position of *B* a certain result, due to the combined action, and if, keeping the direction the same, we shift *B* along the wire a distance corresponding to one wave-length, then, provided the direct disturbance travelled with the same velocity as that along the wire, we should have a result of the same character as at first: if the actions were primarily in the same direction, they would still be so; if they at first opposed, they would still oppose one another. If, however, the actions travelled with un-

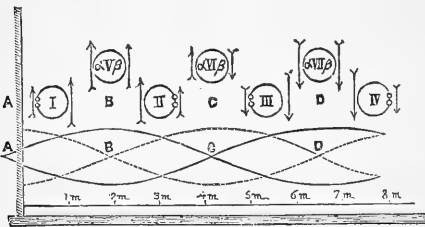

FIG. 10.

equal velocities, they would change their relative directions as the secondary was shifted along the wire,—slowly if the velocities were nearly alike, faster if they differed considerably. This is the result which Hertz obtained; the change of sign taking place, when the observations were at a considerable distance from the primary, in a distance of 7.5 metres,—a result which would give for the velocity in air a value equal to that in the wire multiplied by the ratio of 7.5 to 7.5—2.8, or 320,000 kilometres per second. Considering the very rough methods of experiment, this agrees very well with the velocity of light, which is approximately 300,000 kilometres per second.

But in this experiment a very important fact was developed. While the change of sign took place in a distance of 7.5 metres at points considerably removed from the primary, yet near the primary the change of sign was in a much shorter distance. Now, we have seen that near the primary the electro-static effects are of the

greater importance, while at a distance from it the electro-dynamic actions can alone be considered. It would seem, then, that electro-static actions are propagated with greater velocity than electro-magnetic. It is hard to say from Hertz's results whether the velocity is infinite, since at a distance of 2.8 metres—the half-length of a wave on the wire—the magnetic effects are already of considerable importance. Still it seems fairly well proved that static and magnetic actions are propagated with different velocities, the latter being approximately that of light.

After this experiment, Hertz attempted to obtain evidences of the reflection of electro-magnetic waves from conducting surfaces. To do this, he placed the apparatus in a room whose dimensions were 15 metres in length, by 14 metres in width, by 6 metres high. There was a row of iron columns in the room, which cut off part of the available space, so that the width that could be utilized was reduced to 8.5 metres. All of the gas-fixtures having been removed, one wall of the room was prepared as a reflector by hanging on it a sheet of zinc, which was carefully attached to the gas-pipes and water-pipes. The primary circuit was arranged in a vertical position; the secondary was fitted so it could be moved into any position, this being usually accomplished by hand, although the body of the observer exerted a slight influence on the results. On placing the secondary in different positions between the primary circuit and the wall, results were obtained which are shown in Fig. 10 (Fig. 12 in article). With the secondary in the positions *I*, *II*, *III*, and *IV*, at distances from the wall shown by the scale, the strongest sparks were obtained when the air-space was in the position shown. At *V*, *VI*, and *VII* the same sparks occurred with the air-space at either side. This can be accounted for by supposing the waves to be those shown in the figure, the vibrations from the primary being reflected from the wall. Determining the length of the wave in this way, and assuming that they travel with the velocity of light, we obtain a period of .000000155 for the oscillations, instead of the .00000014 calculated from the dimensions of the circuit.

Such, in brief, are the most important of the results obtained by Hertz. He has developed a new experimental method, which in his own hands, and those of a number of physicists who are without doubt working now on the subject, will greatly extend our knowledge of what takes place in the vicinity of varying electric currents, and which will modify our views on the nature of electric actions. So far Hertz has shown that oscillations of short period can be practically obtained and experimented upon, and he has developed a method of investigation by means of a secondary circuit of a period equal to that of the vibration. He has shown, that, of the electro-static and electro-magnetic phenomena that accompany an oscillation, the former is of great importance near the oscillating current, but rapidly die away as the distance increases. He has shown that dielectrics have magnetic effects when placed near a conductor carrying an oscillating current, thus making more than probable Maxwell's hypothesis of "electric displacement." The velocity of a wave along a wire was determined, and from this the velocity of the electro-magnetic and electro-static waves in air were experimented upon. The former was found to be approximately that of light; the latter was much greater, but it was not possible to determine whether it was infinite. Lastly, electro-magnetic waves were reflected from a conducting surface, and their wave-length determined by the interference of the direct and reflected waves.

Hertz's work has put Maxwell's electro-magnetic theory of light on a firm basis, and has added experimental evidence to what was, after all, only an hypothesis.

ELECTRICITY AND LIGHT.—At a meeting of the Berlin Physical Society, Dec. 14, 1888, Professor von Helmholtz, the president, gave an account of a paper by Professor Hertz, which he had communicated the day before to the Berlin Academy. It contained a description of further experiments on electro-dynamic waves, and their analogy with waves of light. Weak induction discharges between small metallic cylinders with rounded ends were employed, and a similar apparatus for the detection of the electro-dynamic waves. The action was not propagated more than 2 or 3 metres through space; when it fell on a metallic surface, it was reflected, interference phenomena were observed, and from these the length

of half a wave was found to be 30 centimetres. When a metallic parabolic mirror, 1 metre across its opening, was placed behind the apparatus used to produce the discharge, the action was propagated to a distance of 8 metres; and the action was greatly increased when a second concave mirror was placed behind the receiving apparatus. When a conductor was interposed, the action ceased, while non-conductors allowed the waves to pass. By interposing perforated metallic screens, it was found that the waves are propagated in straight lines; the waves passed through a dry wooden partition. Polarization of the waves could be determined in several ways. When the receiver was placed at right angles to the apparatus producing the waves, no action between them could be detected, the vertically produced waves not being picked up by the horizontally placed receiver. When the two pieces of apparatus were placed parallel to each other, and a wooden cube, with a number of insulated metallic wire rings wrapped round it, was placed in the path of the electro-dynamic waves, it produced the same effect as does a tourmaline plate on polarized light. When the wires were vertical,—that is to say, parallel to the exciting apparatus,—the action was not propagated through the cube; but it was, on the other hand, when the wires were horizontal. When the receiver with its mirror was placed horizontally, so that it did not record any action as reaching it, and the wire arrangement described above was placed in the path of the waves, no change took place in the receiver when the wires on the cube were either vertical or horizontal; but the receiver was affected when the wires were placed at an angle of 45° . The laws of reflection of electro-dynamic waves at metallic surfaces were found to be the same as those for the reflection of light at plane mirrors. Finally, Professor Hertz has determined the refraction which the waves undergo in a prism made of pitch, and finds that the refractive index of this substance for electric waves is 1.68. Dr. Ritter demonstrated by experiments the action of the ultra-violet rays of light on electric discharges in accordance with the experiments of Hertz, Wiedemann, and Eberts.

LIGHT MOTORS FOR AERONAUTIC EXPERIMENTS.—M. Trouvé has constructed several small and extremely light motors of the Gramme and Siemens type, in order to carry out some aeronautic experiments. One of these motors, while only weighing about three ounces, is capable of developing .026 brake horse-power. All the parts of the machine are of aluminum with the exception of the magnets. This motor, which could be contained in a box 1.2 inches each way, is able to lift itself twenty-five yards a second by means of a wire and a fixed support. A one-horse-power motor constructed on the same lines would weigh barely eight pounds. When furnished with a light screw, and attached to the arm of a balance, the motor is able to lift its whole weight, when connected with a source of electric energy equal to forty watts. In order to facilitate his experiments, M. Trouvé places his motor at one end of a long lever capable of a vertical and horizontal movement about its centre, the electrical connections being made with the motor through the lever and its supports.

IMPORTANT PATENT DECISION.—In England the court of appeals has just handed down its decision reversing the finding of the lower court in the Edison incandescent lamp patent case. The case had been decided against Edison, principally on the ground of insufficient specification. This last decision upholds the Edison patents, and puts the Edison Company in England in the same position that it enjoys in Germany, where the patents have been uniformly upheld.

NOTES AND NEWS.

THE American Association for the Advancement of Science will meet at Toronto, Aug. 27 to Sept. 3; the first general session to be held on Aug. 28; the council meeting, on the 27th.

—The thirteenth anniversary of the Johns Hopkins University will be commemorated on Friday, Feb. 22, 1889. The public exercises of the day will be held in the Mount Vernon Place Methodist Episcopal Church at eleven o'clock. The public are invited to attend, and no tickets of admission will be required. The exercises in the church will close before one o'clock. The trustees,

faculty, alumni, students, and gentlemen personally invited, will assemble at the university at half-past ten o'clock, and proceed in a body to the church, where seats will be reserved for them. The alumni of the university will have a social gathering with a luncheon after the close of the exercises in the church. The physical laboratory will be thrown open from eight to ten o'clock in the evening to members of the university and their friends, and the chief instruments and pieces of apparatus will be shown to visitors. Professor Rowland will make an address to physicists in the hall of the physical laboratory at half past four o'clock, on "Modern Views with Respect to Electric Currents." Specials cards of admission will be required. Right Rev. Henry C. Potter, Bishop of New York, preached the annual sermon before the Christian Association of the university in St. Paul's Church (corner of Charles and Saratoga Streets) on Sunday, Feb. 17, at 8 P.M.: subject, "The Mastery and Mastering of Circumstances." All members of the university were invited to attend. The University Glee Club gave a concert in the Lyceum Theatre on Tuesday, Feb. 19, at 8 P.M.: tickets, fifty cents. The Athletic Association gave a gymnastic exhibition in the gymnasium on Thursday, Feb. 21, at 8 P.M. Tickets (fifty cents each) had to be obtained at the University Post-Office.

—At a meeting of the American Oriental Society, held at Philadelphia, October, 1888, Isaac H. Hall, Richard J. H. Gottheil, George F. Moore, Edward W. Hopkins, and Cyrus Adler were appointed a committee to obtain information respecting manuscripts that exist in America, written in the Oriental languages or connected with their study, with a view to the ultimate publication of a comprehensive catalogue of the same, in a worthy manner, and calculated to serve all the useful purposes of the Oriental catalogues of the great libraries of Europe. The manuscripts which are the subject of inquiry include all the ancient and modern languages and dialects of Asia, with those of Egypt and Ethiopia, whatever be the subject-matter of the manuscript, whatever be the character of the writing for elegance or negligence, whatever be the material upon which it is written, whatever be its state of preservation, or whatever be its length or size. The points of inquiry include the language of the manuscripts, if known; the style of writing, or the alphabet employed (as, if the manuscript be Arabic, whether in Cuñic or Neski, etc.; if Turkish, whether in Greek, Arabic, or Armenian letters, etc.), and the material upon which written; the size and binding (or absence of binding); number of leaves, and other external particulars of the manuscript; or, if a roll, its dimensions, and the number and dimensions of its columns (of fragments, papyrus, etc., the mere dimensions); the history of the manuscript, as far as known, and how it came into its present hands; if the manuscript is in a public library, both its present catalogue marks, and information respecting any former labels, library marks, or notes of ownership (the latter, of course, are desired if the manuscript is in private hands); also the date of the manuscript, if known.

—The field-work of the irrigation survey of the arid region of the United States is being vigorously prosecuted in Colorado and New Mexico, notwithstanding many disadvantages arising from cold and stormy weather. From Colorado, Mr. W. D. Johnson, in charge, reports the completion of the Pueblo and Huerfano sheet in fifty-foot contours, and on a scale of two miles to the inch, and considerable work done on the Apishapa and Juniata sheets, all being in the Arkansas valley. Mr. Johnson's parties, living in tents, have experienced temperatures below zero, and encountered twenty inches of snow; but such attention has been given to the men, that, beyond a few frost-bites, no trouble has been experienced in prosecuting work on every day not actually stormy. Work in New Mexico on the Lower Rio Grande has been commenced; Mr. R. Henry Phillips, in charge, reporting the arrival of his party at El Paso, and the occupancy of points connecting this work with the base-line measured near Fort Bliss in 1878 by the United States Engineers.

—Mr. Edwin Chadwick, the pioneer of sanitary reform in England, and indeed throughout the world, will, on the anniversary of his ninetieth birthday, March 2, be presented with a congratulatory

address by the Association of Public Sanitary Inspectors of England, of which body he is president.

— The third volume of "Studies from the Laboratory of Physiological Chemistry of the Sheffield Scientific School of Yale University" has just been published, under the editorship of Professor R. H. Chittenden, Ph.D. It contains the following subjects: "Some Experiments on the Physiological Action of Uranium Salts;" "Elastin and the Elastose Bodies;" "The Influence of Urethan, Paraldehyde, Antipyrin, and Antifebrin on Proteid Metabolism;" "The Influence of Several New Therapeutic Agents on Amyolytic and Proteolytic Action;" "Casesses, Caseine Dyspeptone, and Caseine Peptone;" "Some Experiments on the Influence of Arsenic and Antimony on Glycogenic Function and Fatty Degeneration of the Liver;" "The Nature and Chemical Composition of the Myosin of Muscle Tissue;" "Myosinoses, and the Relative Absorption of Nickel and Cobalt."

— The trustees of the Johns Hopkins Hospital have decided to formally open the hospital on May 1, and they have confided its organization to President Gilman of the university. It is said that for one year, at least, President Gilman will reside in the hospital, and exercise a close personal supervision over its executive management.

— Dr. John Call Dalton, one of the foremost physiologists of the world, and a writer of one of the best text-books on physiology, died in New York City on Feb. 12, at the age of sixty-four years.

— The French Association for the Advancement of Science will meet in Paris, Aug. 8-15; and the Congress of Geography and Ethnography will meet there Aug. 5-12. As the great exposition will also be open during August, extra inducements are offered to American scientists visiting Paris this summer.

— The fifth volume of the "Transactions of the American Institute of Electrical Engineers" is now in the hands of the binder. Including the index of current electrical literature, it makes a volume of 638 pages, and is fully indexed. Hereafter the monthly numbers will be paged consecutively, and should be carefully preserved for binding by all who desire to preserve the complete files, as they will not be revised and issued as an annual, as has been done this year in the case of Vol. V. Temporary binders for filing the numbers as received will be furnished by the secretary at seventy-five cents each.

— We have received from Hon. F. G. Adams, secretary, the "Sixth Biennial Report of the Kansas State Historical Society." The number of volumes in the society's library at the present time is as follows: namely, 9,971 bound volumes, 30,353 unbound volumes, 7,981 bound newspaper files and volumes of periodicals; in all, 48,305 volumes. Of the newspaper volumes, 5,757 are of Kansas. The list and tables which the report contains show that there is being made up by this society, for the use of the people of Kansas, a library of history and reference, remarkable in its growth, and still more remarkable in the character and value of the materials which it contains. They show that the growth of the library and collections has steadily continued from year to year during the thirteen years of the society's existence, and that in that time there have been placed on the library shelves more than forty-eight thousand volumes of books, newspaper files, and pamphlets; and, in addition to these, this and former reports show a collection of manuscripts, pictures, statuary, relics, and objects of historical illustration of every kind and description almost countless in number.

— The American Institute of Electrical Engineers (5 Beekman Street, New York), in addition to the letters from the Institution of Civil Engineers and the Society of Arts, has received one from the Institution of Electrical Engineers of London, to the effect that the president and council of that institution, having been informed by Mr. W. H. Preece, one of its past presidents, that many of the members of the American Institute will be visiting the Paris Universal Exhibition this year, and will probably also visit London, will take pleasure in welcoming those gentlemen, and in doing all that is in their power to render their visit to England agreeable and instructive. Communications of the same tenor, addressed to

the American societies of civil engineers, mechanical engineers, and mining engineers, led to the organization of an excursion, by which the members of those bodies were enabled to secure two special steamers, at the reduced rate of one hundred and ten dollars for the round trip to Liverpool. On account of the uncertainty as to proper accommodation in those steamers, and the early date of their departure (about June 1), the council of the American Institute does not deem it expedient for the electrical engineers to unite in the same arrangement, as the date fixed for the electrical conference at Paris (the latter part of August), together with the probability of the exhibition being in an incomplete condition, points to the desirability of fixing the date of departure about Aug. 1. Members who propose making the trip are, however, requested to notify the secretary as to the date of departure and return which would be most convenient for them; and, should it be found that a sufficient number agree approximately upon a date, an effort will be made to secure special rates. The regular excursion fare for first-class accommodations is one hundred and eighty dollars.

— In *The Microscope* for February, 1889, A. Clifford Mercer, M.D., describes a method of using with ease objectives of shortest working distance in the clinical study of bacteria. The working distance of homogeneous immersion objectives of short focus and great numerical aperture is little. In the clinical study of bacteria, sputa and other more or less fluid material are generally prepared on the under surface of cover-glasses, commonly, when not measured and assorted, so thick as to make examination with the above most suitable objectives impossible. To avoid this difficulty, Dr. Mercer dries and stains the material on the slide, drops homogeneous immersion fluid upon the preparation, and lowers the objective into the drop. Homogeneous fluid replaces both the balsam and the cover-glass with optical propriety. A twenty-fifth, which has been nearly useless over ordinary cover-glass preparations, is now used with gratifying freedom in manipulation over uncovered, but homogeneously immersed, slide preparations.

— The following is the list of the officers of the Kent Scientific Institute of Grand Rapids, Mich., for 1889: president, E. S. Holmes; vice-president, W. A. Gruson; recording secretary, C. W. Carman; corresponding secretary, E. S. Holmes; treasurer, C. A. Whittemore; director of the museum, W. A. Gruson; curator, C. W. Carman; librarian, E. L. Mosely; board of directors, Wright L. Coffinberry, W. A. Gruson, Samuel L. Fuller, E. S. Holmes, J. W. Jones, C. A. Whittemore; officers of the board, W. A. Gruson (chairman), E. S. Holmes (secretary), C. A. Whittemore (treasurer).

— The art schools of the Metropolitan Museum of Art have been established by the trustees of the Metropolitan Museum of Art, in order to furnish superior opportunities for thorough instruction in design, modelling, color, freehand, architectural, cabinet, and perspective drawing, chasing and hammered-metal work, carving in wood, painting on china, etc., especially to those who desire to acquire an artistic education applicable to industrial and commercial uses. Large, new, well lighted and ventilated rooms have been provided in a central position, with superior art material and instruction, and a liberal basis of admission. In order to offer all genuine students every facility in their work, a series of lectures have been added, the privilege of visiting the museum free of expense, prizes, diplomas, and opportunities for the sale of meritorious work; so that all may measure their progress by the degree of their industry and application. All payments are to be made in advance. Applicants for admission to the school must bring a letter of introduction from some resident of good standing. It is desirable that intending students should bring samples of their work to determine the degree of their proficiency. Those who follow the full course in each department receive diplomas upon passing a satisfactory examination at the close of the final term. The full courses are:—Drawing and painting, three seasons: 1st, Introductory class; 2d, "Antique" class; 3d, Life class. Sculpture, three seasons: 1st, In one of the drawing classes; 2d and 3d, In the modelling-room, with attendance at the anatomy lectures. Architecture, three seasons, the course to include architectural drawing, history and mathematics. It is intended that those who follow this course should be sufficiently advanced to pass the examinations of the

Paris Ecole des Beaux Arts. Diplomas will be issued to members of the normal, decoration, metal, wood-carving, and cabinet drawing-classes who have previously passed a season in one of the drawing-classes, and have shown satisfactory progress.

— A technical laboratory for special instruction in dyeing and bleaching, says *Nature*, has just been opened in connection with University College, Dundee. This technical portion of the chemical department consists of a completely fitted dye-house, a laboratory, and a museum for technical samples, more especially connected with the textile industries of the district. Practical instruction in the dye-house was begun by Professor Percy Frankland last week.

— It is well known that the aurora has a period of eleven years corresponding to that of terrestrial magnetism and of sunspots. It has recently been proved that the magnetical phenomena have a period of twenty-six days. This fact suggested to Mr. J. Lizar the plan of attempting to find a corresponding period in the frequency of the aurora. He subjected the hourly observations of the polar stations at Bossekop, Jan Mayen, and Fort Rae, in 1882-83, to an investigation, and found a very distinct period of this length, the maxima and minima of which corresponded exactly to those of the magnetic period. From this fact Mr. Lizar concludes that the connection between aurora and terrestrial magnetism is still closer than has been heretofore supposed.

— The tenth session of the International Congress of Anthropology and Prehistoric Archaeology will meet in Paris Aug. 19-26. The programme, subject to additions, is as follows: (1) "The Erosion and Filling-up of Valleys and the Filling-up of Caves in their Relation to the Antiquity of Man;" (2) "The Periodicity of Glacial Phenomena;" (3) "Art and Industry in Caves, and the Value of Paleontological and Archaeological Classification when applied to the Quaternary Epoch;" (4) "Chronological Relation between the Stone, Bronze, and Iron Ages;" (5) "Relations between the Civilizations of Hallstadt and the Other Danubian Stations and the Civilization of Mycenæ, Tirynthus, Issarlik, and the Caucasus;" (6) "A Critical Discussion of the Skulls and Quaternary Bones described in the Last Fifteen Years, with an Examination of the Ethnological Elements Characteristic of the Stone, Bronze, and Iron Ages in Central and Western Europe;" (7) "The Light which Ethnographical Survivals can throw on the Social State of the Early Populations of Central and Western Europe;" (8) "How far can Archaeological or Ethnographical Analogies be used to support Hypotheses in regard to Race Connections or Prehistoric Migrations?"

— The council of the Royal Meteorological Society, says *Nature*, have arranged to hold at 25 Great George Street, Westminster (by permission of the council of the Institution of Civil Engineers), on March 19-22 next, an exhibition of instruments connected with atmospheric physics invented during the last ten years, especially those used for actinic and solar radiation observations. The exhibition committee invite the co-operation of all who may be able and willing to send contributions. The committee will also be glad to show any new meteorological instruments or apparatus invented or first constructed since last March, as well as photographs and drawings possessing meteorological interest.

— *Germania*, a quarto fortnightly journal for the study of the German language and literature, edited by A. W. Spanhoofd, has just been published at Manchester, N.H.

— *Leif Erikson* is the title of a new journal to be published weekly at Chicago, under the editorial management of Miss Marie A. Brown, to prove, among other things, that the Norsemen discovered America, and that Columbus was an impostor.

— It is reported from north central Norway and Sweden, so says *Nature*, that wolves are very numerous this winter. They have re-appeared in districts where they have been unknown for many years.

— A new magazine for the blind, in raised Braille type, will shortly make its appearance in London under distinguished patronage. It will contain original articles and reprints of literary matter

of a high class, by the best authors of the day, politics being excluded.

— Brentanos have opened a branch at No. 430 Strand, London, which they intend to make "the headquarters of Americans in Europe, as is already the case with their house in Paris, by offering them all possible facilities for keeping fully informed of the doings of American authors and publishers."

— The German Government has granted, according to *Nature*, the sum of £27,500 to repair the building of the University of Berlin, and to erect new lecture-rooms, staircases, and corridors, and for the heating and lighting apparatus. The government has also given £36,500 to the Natural History Museum, besides £2,500 for books. A further sum of £1,000 is to be devoted to the purchase of physical apparatus and an anatomical cabinet.

— We have received a specimen copy of the *Interpreter*, an international review for universal language, edited, with assistance of numerous linguists of different nationalities, by Karl Lentre (Leipzig, Flossplatz 310). It appears monthly, and the subscription price is 50 cents half-yearly. The movement for a world-speech has now entered a new phase of evolution. Whereas formerly only persons of very limited capacity of judgment in linguistic matters have taken up Volapük, the idea of a national artificial speech is now gaining ground more and more among linguists, who examine Volapük and other similar attempts critically and scientifically. This procedure, however, does not suit the Volapükists, who opine that the faults and failings of a system do no harm if only the invention itself can be used. This standpoint is, however, quite untenable, for a language which cannot bear the test of scientific criticism is not likely to possess qualities insuring its lasting success. The *Interpreter*, published in English, German, and French side by side, is to be a central organ for scientific criticism in the department of world-speech, and will also furnish to those who have as yet kept aloof from this movement an opportunity to form a judgment as to the characteristics of Volapük, contrasted with those of a real world-speech gradually to be evolved. The articles in the first number are conceived in this sense. The *Interpreter* is likewise well-adapted, by the way, for the pursuance of studies in German or French. Specimen copies may be had of the publisher, in America, of E. G. Hethorn, New York, P. O. Box 2571.

— The following are from the table of contents of the March number of *The Chautauquan*: "Gossip about Greece," by J. P. Mahaffy of Dublin University; "Alcibiades," by Thomas D. Seymour of Yale University; "Greek Art," by Clarence Cook; "Color in the Animal World," by the Rev. J. G. Wood; "Industrial and Social Effects of the Sewing-Machine," by Ernest Ingersoll; "The Care of Criminals," by the Hon. Z. R. Brockway, general superintendent of New York State Reformatory; "The Commercial Relations of American Countries," by Professor A. D. Morse of Amherst College; "Embezzlers and Defaulters," by John Habberton; "The Italians in the United States," by C. L. Speranza of Columbia College; "The Gladstone Fortune," by C. DeVarigny; "Water-Supply for Small Towns," by John S. Billings, M.D., surgeon United States Army.

— We learn from *Nature* that Professor Fitzgerald and Mr. Trouton have been conducting experiments confirmatory of Hertz's magnificent work. Lately, using parabolic mirrors after the manner Hertz recently described, they have observed the phenomenon of the polarization of radiations by reflection from a wall three feet thick. They observed long ago, and exhibited publicly at the opening meeting of the Experimental Science Association last November, that stone walls are quite transparent to these radiations, as they should be, and consequently should not reflect radiations polarized perpendicularly to the plane of incidence at a certain incidence. This is what has been observed, and it has been decided that the plane of polarization is the plane of the magnetic disturbance. They next tried reflection from sheets of glass, and obtained no results; but, as Mr. Joly suggested, the experimenters were practically observing the black spot in Newton's rings, for the sheet of glass was much thinner than a wave-length, which is about thirty centimetres. Some rough observations at various incidences from the wall seem to show interference at some and not at other incidences due to the same cause as Newton's rings.

SCIENCE:

A WEEKLY NEWSPAPER OF ALL THE ARTS AND SCIENCES.

PUBLISHED BY

N. D. C. HODGES,

47 LAFAYETTE PLACE, NEW YORK.

[Entered at New York Post-Office as second-class mail-matter.]

SUBSCRIPTIONS.—United States and Canada.....	\$3.50 a year.
Great Britain and Europe.....	4.50 a year.
Science Club-rates for the United States and Canada (in one remittance):	
1 subscription 1 year.....	3.50
2 " " 1 year.....	6.00
3 " " 1 year.....	8.00
4 " " 1 year.....	10.00

Communications will be welcomed from any quarter. Rejected manuscripts will be returned to the authors only when the requisite amount of postage accompanies the manuscript. Whatever is intended for insertion must be authenticated by the name and address of the writer; not necessarily for publication, but as a guaranty of good faith. We do not hold ourselves responsible for any view or opinions expressed in the communications of our correspondents.

VOL. XIII. NEW YORK, FEB. 22, 1889. No. 316.

CONTENTS:

PRACTICAL ELECTRIC-RAILWAY PRO- PULSION.....	133	PHOTOGRAPHIC MAP OF THE NOR- MAL SOLAR SPECTRUM.....	142
THE WORTHINGTON INDEPENDENT CONDENSER.....	134	THE EARTHQUAKE OF LIGURIA, FEB. 23, 1887.....	143
THE DEVELOPMENT OF THE POT- TERY INDUSTRY OF THE UNITED STATES.....	136	NATURE AND ORIGIN OF PHOSPHATE OF LIME.....	144
HEALTH MATTERS.		BOOK-REVIEWS.	
Yellow-Fever.....	136	Social Progress.....	148
Legal Regulation of Medical Prac- tice.....	137	Scientific Religion.....	148
Contagiousness of Consumption.....	136	German Commercial Correspond- ence.....	148
Doctors Advertising.....	137	French Commercial Correspondence.....	148
Public Medical Libraries.....	137	Elements of Plane Analytic Geome- try.....	149
Danger in the Postage-Stamp.....	137	The Beginner's Reading Book.....	149
Sanitary Plumbing.....	137	AMONG THE PUBLISHERS.....	149
ELECTRICAL NEWS.		LETTERS TO THE EDITOR.	
Hertz's Researches on Electric Os- cillations.....	137	O'Reilly's "Greenland" <i>John Murdoch</i> 150	
Electricity and Light.....	138	The Soaring of Birds <i>W. H. Piskering; J. G. MacGregor</i> 151	
Light Motors for Aeronautic Experi- ments.....	139	Some Habits of the Omahas <i>J. Owen Dorsey</i> 152	
Important Patent Decision.....	139	Sawdust Explosion <i>Robert Bell</i> 152	
NOTES AND NEWS.....	139		
EDITORIAL.....	142		
United States at the Paris Exhibition.			

THE UNITED STATES will make a creditable display at the Paris Exhibition. And this is as it should be; for, although nominally a universal exposition, it will be practically a display of the products of republics. The monarchies of Europe will be represented only by private exhibits, while the republics of North and South America have rallied in force. The United States Department of Agriculture will make a splendid showing. Secretary Colman has placed the undertaking in the hands of Professor C. V. Riley, the famous entomologist, an energetic organizer as well as a careful and enterprising scientific observer; and Professor Riley has already sent forward three car-loads of products, which are on the way to France in charge of Mr. F. T. Bickford, an assistant. The bulk of shipments are nearly through with, and the perishable staples will follow during the next month. Congress appropriated \$250,000 to aid exhibitors, and Secretary Colman's quota of this will insure the best illustration that the agricultura. resources of this country have ever had on the continent of Europe. Various branches will be represented as follows: fruit, Professor VanDeman and Professor George Hussman; grain, George N. Hill, St. Paul, Minn.; cotton and fibres, Col. James A. Benford, Duck Hill, Miss., and Charles R. Dodge, Boston; tobacco and peanuts, Alexander McDonald, Va.; agricultural education and

experimental stations, W. O. Atwater, Department of Agriculture; vegetables, including hops, M. G. Kern, St. Louis; entomology, including apiculture and silk-culture, C. V. Riley, N. W. McLean of Hinsdale, Ill., and Philip Walker, Department of Agriculture; sorghum and other sugar-plants, H. W. Wiley, Department of Agriculture; forestry, B. Fernow, Department of Agriculture, and M. G. Kern of St. Louis; grasses and forage-plants, George Vasey, Department of Agriculture; meat products, Dr. de Salmon, Department of Agriculture. All articles for exhibition will be forwarded free from New York, and no charge will be made for space in Paris. Professor Riley has put forth unusual exertions to get the exhibit on the road, and he looks forward with much enthusiasm to the result. He will not leave for Paris till the first week in April.

PHOTOGRAPHIC MAP OF THE NORMAL SOLAR SPECTRUM.

A NEW and greatly improved edition of this map, made by Professor H. A. Rowland, extending from the extreme ultra violet down to and including B to wave-length 6950, is now ready. The old map, published in 1886, was made by means of a grating ruled on the old dividing-engine, which was originally intended for only small gratings, and at a time when Professor Rowland's knowledge of photography was limited. Furthermore, it was not printed in a sufficiently careful manner; and the negatives, which were originally none too good, soon became broken or defaced, so that many of the prints, especially the later ones, were not satisfactory.

The whole work has now been gone over again. A new dividing-engine to rule large gratings has been constructed, and has proved to be superior in every way to the old one, although the old one is almost equal to it for small-size gratings. It has been placed in the vault of the new physical laboratory, where an almost constant temperature is maintained. Several concave gratings of 6 inches diameter and $2\frac{1}{4}$ feet radius have been ruled with 10,000 or 20,000 lines to the inch, giving definition hitherto undreamed of. These have been mounted in the best possible manner. The laboratory contains rooms for developing, making emulsions and dry plates, complete enlarging apparatus, and, indeed, every facility for photographic work on the spectrum of the sun; and a large steam-engine, a variety of dynamos, continuous and alternating current, with Ruhmkorff coils of all kinds, one of which latter will melt down iron wire larger than one-sixteenth of an inch in diameter in the secondary circuit, give means of future investigation on the spectrum of the elements. Professor Rowland has devoted years to the making of dry plates, simple and orthochromatic, and is thus better prepared than before for the work of making the map. He has also revised his list of standard wave-lengths, and extended them into the ultra violet, and has placed the scale upon the photographs with greater care than before. The printing is carried on in Baltimore, where it is under the immediate supervision of Professor Rowland.

The negatives have been made on thick French plate glass, and the prints are much more artistic than the old ones. The definition is not only much finer throughout, but the prints are much more uniform, and have fewer spots.

The process of making this map is the same as that used for the old one, and is based on the property of the concave grating as discovered by Professor Rowland: this property is, that the spectrum, as photographed in any given order, is normal, and of the same scale throughout. The focus remains automatically adjusted, so that one has only to move the instrument to the part of the spectrum required, absorb the overlying spectra, and put in the photographic plate. The negatives enlarged have been selected from many hundreds taken from different gratings, though three gratings were finally selected for the work. The negatives from any given order of spectrum are measured from one standard line to another on a dividing-engine, so that the constant of the dividing-engine is known. The scale is then made by ruling on a piece of French plate glass having a coating of blackened collodio-chloride. The negatives are then clamped to the scale firmly, after being adjusted into position by the standards. They are then put in the enlarging apparatus, and the whole enlarged from two and a half to possibly

four times, so as to make the scale of the map about three times, that of Angström's map. The positives thus made are then figured, and negatives made from them by contact.

In the negatives so far examined, the scale has been placed within less than $\frac{1}{10}$ Angström division, or $\frac{1}{100000}$ wave-length of its true position.

As to the definition, much is lost in the enlargement, not so much from want of definition in the enlarging lens, a 25 by 21 inch Dallmeyer, rapid rectilinear, as from the radical defect of photographic processes; for, when one brings out the fine doubles in which the streak of light in the centre is very faint, he loses many of the fainter lines. The original negatives show E, and even finer lines like that at wave-lengths 5276.1 and 5914.3, plainly double, but there is little hope of showing this on the map.

The atmospheric line just outside of one of the D lines also nearly merges into it, although in the original negative it is widely separated from it.

However, there are few instruments which will show more of the spectrum than can be found on the map, even below the D line, where cyanine and chlorophyl plates had to be used, for the first line in B is shown widely triple. Above, and including the D line, the definition rapidly improves, and a low-power magnifier must be used to bring out the full definition. However, from wave-lengths 5300 to 3800 the superiority over the old edition is not so marked as above and below this. In the ultra violet above H there is an immense improvement in the new, both in definition and in the quality of the photograph.

As to comparison with other maps of the spectrum made by measurement and drawing, it may be said that no comparison is possible. The photograph is the work of the sunlight itself, and the user of this map has the solar spectrum itself before him, and not a distorted drawing full of errors of wave-length and of intensity. The superiority is so great that there is no possibility for comparison.

The following is a list of the plates, each 3 by 2 feet, containing two strips of the spectrum: *a* includes from wave-length (?) to 3350; *b*, from wave-length 3270 to 3730; *c*, from wave-length 3670 to 4130; *d*, from wave-length 4050 to 4550; *e*, from wave-length 4450 to 4950; *f*, from wave-length 4850 to 5350; *g*, from wave-length 5250 to 5750; *h*, from wave-length 5650 to 6150; *i*, from wave-length 6050 to 6550; *j*, from wave-length 6450 to 6950.

Negatives *b*, *c*, *d*, *e*, *f*, *g*, *h*, *i*, *j*, are now ready, although that for *i* is too irregular to be entirely satisfactory, and it may be replaced. The plate *a* to the extremity of the solar spectrum will be attempted this summer, but may cause much trouble and delay, and will be sold as an extra plate. The prints are on heavy albumen paper mounted on cloth.

The cost of printing has been so much increased that the prices for this new series will be greater than for the old one, but scarcely more than covers the cost of the printing.

The plates will be delivered in Baltimore or New York, or will be sent by express or mail, securely packed, at the charge and risk of the purchaser, at the following net prices: set of nine plates, wave-length 3270 to 6950, \$18; single plates, \$2.50. Should any extra plates continuing the spectrum in either direction be published, subscribers can have them at \$2 each. Subscribers to the old edition will have the preference in the delivery of the new one, and a reduction of 10 per cent in the price. The three plates *h*, *i*, *j*, to complete their set, will be furnished for \$6. They are advised to take *g* also, as the old map of that region was bad. The four, *g*, *h*, *i*, *j*, will be furnished to them for \$8.

Two plates, each 3 by 2 feet, suitable for framing and hanging on the wall, have been made of the B and D lines. The latter are 3 inches apart, and the former has an extent of about 24 inches. Enlargements of some of the carbon bands from the arc electric light have also been made. They show the wonderful structure of these bands, each containing many hundred lines, each one of which is a close double, or, in some cases, a triple. These plates will be sold for \$2.25 unmounted, or \$2.50 mounted on cloth. No plate will be given away or sent in exchange. Remittances may be made by draft or money-order. All subscriptions and orders should be sent, and remittances made, to the Publication Agency of the Johns Hopkins University, Baltimore, Md.

THE EARTHQUAKE OF LIGURIA, FEB. 23, 1887.

MESSRS. T. TARAMELLI and G. Mercalli have made an exhaustive report on the earthquake of Liguria in February, 1887, to the Italian Department of the Interior. A geological and an historical chapter form the introduction, which is followed by an account of the results of the authors' studies and inquiries. They visited all localities that were severely damaged by the shocks, while information on others, which they were not able to visit, was collected by means of circulars of inquiry. Thus exhaustive reports on the character of the earthquake were obtained from over eleven hundred localities. This abundant material, arranged and discussed systematically, forms the basis and the main part of the report. The results of this discussion are summarized by the *Naturwissenschaftliche Rundschau* as follows:—

Many insignificant, preparatory shocks preceded the Ligurian earthquakes of 1752 and 1854, as well as that of Feb. 23, 1887. In the night from Feb. 22 to Feb. 23, four light shocks were felt over exactly the same territory that was visited by the severe shocks of the following day. Evidently the seismic centre was in full activity that night; but there are only four indications, as no seismic instruments and observers exist on the Riviera di Ponente. A little while before the earthquake began, the sea was observed to be exceptionally quiet. A few observers claim to have seen unusual lights in the atmosphere. In the regions which suffered most severely, animals were observed to be restless. In a very few places a change of springs was observed. Thermometer and barometer were not influenced by the shocks.

The principal shock was observed in a circular area covering about 568,000 square kilometres. Its southern limit is Rome and Mount Ferru in Sardinia. Eastward it extends to Pordenone, westward to Perpignan, and northward to Dijon and Basle. The shocks spread with greater force northward to France and western Switzerland, than southward on the Italian peninsula. According to the intensity of the phenomena, the authors distinguish four zones; the central region, in which the most formidable destruction took place, forming a zone a hundred kilometres in width along the coast from Mentone to Albissola. It embraces a narrow coast strip, because the seismic centre was situated in the sea, and because the old crystalline rocks of the Ligurian Apennines reflected the seismic waves. The next zone is called by the investigators the "almost destructive" one. It extends to the hills of Piedmont. Very strong shocks were felt in the third zone, which extends from the second principally north-westward, including Turin and the low-lying Canavese, where the shocks seem to have been increased in violence by waves reflected from the gneissic mass of the Grand Paradiso. The last zone embraces those places in which the earthquake was felt, but did not do any damage.

In the whole territory where the earthquake was strongly felt, the first shock lasted thirty seconds, and consisted of two shocks almost immediately following one another. Each of these shocks caused first a subsultory, then an undulating motion. In no place, not even in those where the shocks were most destructive, was the movement vertical. Therefore the resultant of both shocks was much influenced by local causes, and neighboring places show great differences in the direction of the shocks. The second shock was the stronger one, causing particularly a strong subsultory movement. Only in Nice and other places in France the first shock was the strongest. The second part of the shock was everywhere complicated by the resultant action of its combination with the first shock. This accounts for the fact that the second shock frequently left the impression of a rotatory movement. In many places, for instance in Mentone, objects lying on the ground have been turned round. In places lying at greater distances from the central point, the vertical component decreased rapidly, but all the other peculiarities of the shock remained. In the outlying zone the slowness and regularity of motion of the shock were remarkable, which caused pendulums three feet and more in length to swing.

At various places the horizontal velocity caused by the shock was determined by observations, and by objects thrown some distance. At Oneglia the force was large enough to give a portion of a sill, weighing about five thousand pounds, an initial velocity of thirty-one feet. This horizontal force decreased with increasing distance

from the centre. At Taggia it was twelve feet; at Nice, fifteen feet.

In many places of the region where the earthquake displayed its greatest power, some observers claim to have heard a noise preceding the motion. To some it seemed to be similar to the rattling of a train; but it is more generally compared to the howling of a hurricane, or to the rattling of a cart rolling over a stone pavement, or to distant thunder. Even in the third zone there are numerous places in which the noise was heard before or during the shock. In the fourth zone it was noted in very few places. In several places in the province of Porto Maurizio a subterranean noise was all that was observed; it was not followed by any movement.

Great care was given to the determination of the direction of the first shock. The methods applied were to inquire into movements of lamps and other hanging objects, the stopping of pendulum clocks, the removing or falling of objects, and the destruction of buildings. This part of the investigation showed, that in the whole region of the Ligurian Apennines, which was shaken most violently, all directions were equally frequent. This fact suggests the existence of an elongated epicentre parallel to the Ligurian coast. East of the meridian of Oneglia, directions between east-north-east to west-south-west and north-east to south-west prevailed. West of this meridian the greater number of waves were in the directions from east to west and from south east to north-west. In many places the direction of the movements changed once or twice during the first shock. Thus movements resulting directly from the shock, and secondary waves, could readily be distinguished. In many cases, among the various directions, two were prevalent which were vertical on one another.

A remarkable phenomenon was observed in the valley of Padua. The direction pointing towards the centre of the disturbance existed only during the latter part of the shock. In the beginning the crystalline rocks of the West Alps, which were shaken a few moments before the neighboring recent deposits, deflected the waves towards the arc of the valley of Padua, giving them an east and west direction.

If all important directions of shocks are marked on a map of western Liguria, they will be seen to converge in the sea between Oneglia and St. Remo about fifteen or twenty-five kilometres south of the coast. Therefore this is the probable place of the epicentre. The same place results from a study of the isoseismic lines which are concentric to a point twenty kilometres south of Porto Maurizio. A secondary centre seems to have been in the sea south of Nice.

A comparison of the most trustworthy reports shows that the Ligurian coast between Nice and Laona was struck by the great shock at 6.20 A.M.: therefore the shock must have reached the epicentre a little before this time, probably at 6.19 A.M. If this movement is considered the beginning of the shock, and the time of the disturbances observed at other places is compared to it, it appears that the velocity of transmission was not equal in all directions. It was greater to the west, being 4,762 feet in the direction of Marseilles and Nice, and only 1,916 feet in that of Genoa. This difference is probably not real, as the first shock of Nice seems to have originated at a secondary epicentre south of Nice, the existence of which was known through the earthquakes of 1564 and 1752.

Only in a few places was it possible to ascertain the vertical angle of the shock with any degree of exactness; but the value of 40° seems to be well assured by observations between St. Remo and Albenga. Based on these observations, and on the fact that this angle decreased with increasing distance from the epicentre, slower than it did in the great Andalusian earthquake of Dec. 25, 1884, the seat of the centre was found to be at a depth of eighteen kilometres, while that of the secondary centre south of Nice was somewhat less. It seems probable that the shocks preceding and following the most violent one also proceeded from the main centre, but that the first originated in a greater, the later in a less depth. The centre seems to have approached the surface during the seismic phenomena.

The violent shock was felt at sea between Corsica and the western Riviera by several vessels, which were shaken in all directions, the impression being that they had struck a rock. Almost everywhere on the Riviera the sea fell a little at the moment of the first

shock, and suddenly returned to its former level, without the destructive waves which have followed other earthquakes. Some observers maintain that the falling continued several days after the earthquake, while at Laona and Porto Maurizio a change of level is said to have taken place. No rise is said to have followed the first fall. At Nice, St. Remo, and Savona dead fish were collected after the earthquake. According to Bellotti, all of them were deep-sea fish: therefore it cannot be doubted that violent shocks occurred in considerable depths near the coast of Liguria. This confirms the opinion that the centre must have been under the sea.

The earthquake did not cause any important changes in the topography of the affected region, and all of them must be considered dynamical effects of the tremors upon the surface strata which were broken or slightly moved. None of the resulting changes are connected with the prime cause of the earthquake. No atmospherical phenomena proving the presence of an extraordinary amount of atmospherical electricity were observed. In this respect the Riviera earthquake differed from that of Andalusia.

About nine minutes after the first shock a second one followed, violent and long; then at 8.53 A.M. (Rome time) a third one, short, but almost as violent as the first, and very destructive in its effects. Both these shocks were felt slightly in the whole region disturbed by the first one. In the central zone about twenty-two shocks more were felt in course of the 23d and in the following night. Only one, at 2.20 P.M., was strong. After the 23d the number of shocks decreased; but they continued until March 11, when the most violent shock since the first three was felt. At Savona, between Feb. 23 and March 11, about fifty distinct shocks were felt. Only the shocks of Feb. 23 were destructive. Six hundred and forty persons were killed, and about as many wounded. The damage in the province of Porto Maurizio is estimated at \$2,600,000; in the environs of Albenga and Savona, at \$1,700,000. No detailed estimates are available from the French districts.

NATURE AND ORIGIN OF PHOSPHATE OF LIME.¹

THE circumstances which have led to the preparation of the subjoined report on mineral phosphates are as follows: viz., in 1870 the present writer was employed by the superintendent of the Coast Survey, the late Benjamin Peirce, to examine the phosphate beds of South Carolina with a view to determining the limits of that field; it was also deemed desirable to ascertain, if possible, the conditions which led to the formation of the deposits.

It was at that time the intention of Professor Peirce to have the geology of the belt of country within the limits of the Coast Survey maps carefully determined, so that they might be shaped in a way that would better serve the commercial interests of the country, and also have a greater scientific value. After a time it appeared that there were legal difficulties in the way of publishing these studies in the reports of the Coast Survey, and this work was suspended. It was the hope of Professor Peirce to secure a modification of the law; but before this was accomplished, he retired from the post of superintendent, and his successor deemed it best to abandon the project. During the two years in which I was engaged in this work on the geology of the coast line, I became very much interested in the problems connected with the origin and distribution of phosphatic deposits. From 1873 to 1880, while employed as State geologist of Kentucky, I had a chance to see a good deal of the somewhat phosphatic limestones of the Cambro-Silurian sections, — a set of beds which, by their decay, have given great fertility to the soils that lie upon them. The researches of Dr. Robert Peter, the chemist of that survey, made it plain that the phosphatic contents of the soils are among the first materials to be exhausted by the careless tillage which characterizes our American agriculture, and that they are the most costly to restore to the soil.

Extending the general inquiry to the grain-producing districts which lie to the north and west of Kentucky, it became evident that all those States which are now the granary of this country, and the chief source of supply for European markets as well, are rapidly exhausting their soils, and will soon be in grave need of

¹ Portion of an introduction, by N. S. Shaler, to a forthcoming bulletin of the United States Geological Survey, prepared by R. A. F. Penrose, jun.

phosphatic manures. The importance of such manures has so far been well recognized only by the cotton-growers of this country, yet it is evident that in a short time this class of fertilizers will be equally in demand for all forms of grain-crops.

These considerations have led me to the conclusion that the geological history of phosphatic deposits should receive more deliberate attention than has yet been given to it.

When I began my work in the United States Geological Survey, I asked permission of the director to continue my studies on phosphatic deposits. There was at the time no money available for these studies: it was therefore necessary that they should be carried on without other expense to the survey than that involved in the small share of my time which could be given to the supervision of the work. It was my good fortune, however, to find in one of my students of geology, Dr. R. A. F. Penrose, jun., a person who has been willing, at his own cost, to undertake a preliminary study of the whole field as far as our knowledge extends, and thus to prepare the problems concerning American phosphate deposits for detailed inquiry. This work he has pursued with great intelligence and energy during the two years in which he has been engaged in it. In this task he has examined all the known phosphate deposits of the United States and Canada, and has made a careful inquiry into the literature of the subject, as is shown by the extended bibliography which is appended to his report.

The object of this work being to make a necessary preparation for the further study of American phosphatic deposits, Dr. Penrose's studies were not designed to be encyclopedic in their scope, but rather to afford a synopsis of what is known of the deposits in this and other countries. So little is yet generally known of the several conditions under which these deposits may occur, that it would be very blind work to search for them in this country without a careful endeavor to bring together the experience which has been gained in other countries. It will be evident to the reader of Dr. Penrose's report that the workable deposits of phosphates are found in a greater variety of circumstances than those which contain most mineral substances that have an economic value. It is not likely that we have as yet exhausted the inquiry into the modes of occurrence of this substance; but this synopsis of the experience in this and other countries, which is much more extensive than any other which has been published, will, I believe, serve as a guide to the further search for sources of supplies of phosphatic manures. It will also be evident to the reader that the conditions of occurrence of these deposits in Europe make it plain that the search for them in this country may advantageously be directed to many districts in which they have not as yet been found.

So far, the vein deposits of apatite, such as those which are so abundant north of the St. Lawrence, have not been found in workable quantities within the limits of the United States, though the general geological conditions of the Laurentian area exist in the Adirondack district and in the southern parts of the Appalachian system, as well as in several districts of the Rocky Mountains. It would be remarkable if extensive deposits of this nature, so common in Canada and in the equivalent rocks of northern and southern Europe, should not be found at many points in our American Archæan formations. It is on this account that so much space in this report is given to the description and illustration of the Canadian apatite deposits. So, too, we may hope to find in the ancient rocks of this country deposits analogous to the great Logrosan and Caceres veins in the province of Estremadura, Spain.

The cretaceous deposits of Belgium (which at the present time are, next after the phosphate beds of South Carolina, the most productive in the world) present a type of beds the like of which have not as yet been discovered in the United States, though deposits of the same age, formed under about the same conditions, abound in this country. It is not to be expected that phosphatic deposits will exactly repeat themselves in strata of the same age in widely separated regions; yet it is clear, from the summary account of the geological distribution of these phosphates in Europe and North America, that in the case of these, as well as in that of other substances of value in the arts, there are certain guiding principles which we may base on the stratigraphy of the deposits to aid our search. The known workable deposits of a phosphatic nature are limited to certain portions of the geological section. Beginning at

the surface, the deposits now forming these zones are, in descending order, as follows:—

(1) Superficial deposits, including (*a*) those formed in the manner of guanos; (*b*) the deposits formed in the bottoms of fresh-water swamps, sometimes in connection with deposits of bog iron ore (hematite); and (*c*) deposits which are the result of the long-continued decay of rocks containing a small portion of lime phosphate intermingled with lime carbonate, as, for instance, the deposits of North Carolina. This superficial group of deposits has no other common feature save that they are on the surface, and are due to causes now or recently in action.

(2) Deposits of the tertiary and upper cretaceous. These deposits are generally the result of re-actions which took place on ancient land surfaces, the phosphatic matter being such as formed in swamp beds or in ablation deposits like those of the Carolinas or of eastern England. Below the level of the cretaceous no important deposits of phosphate have been found in the vast section of rocks which lies between that era and the Devonian horizons.

(3) In the horizons below the level of the upper Silurian, bedded rock phosphates and apatite deposits occur. These infra-Devonian bedded rock phosphates seem to have derived their phosphatic matter from the animals, brachiopods, and small crustaceans, which separated that substance from the sea insects or other food which the old oceans afforded them. These phosphate-bearing invertebrates appear to have been particularly abundant in the early paleozoic seas.

(4) Below the level of the Silurian the phosphatic deposits which have been worked probably belong altogether to the class of apatites or crystallized lime phosphates, and are probably all new deposits. They evidently occur through a large part of the Laurentian section, though, so far, the known deposits of economic importance are possibly limited to one portion of that vast series of rocks.

The apparent absence of phosphatic deposits of economic importance in the section between the Devonian and the cretaceous is remarkable. It is possible that it may be due to our lack of knowledge as to the chemical character of the deposits in those parts of the earth's crust. It is more likely, however, that such deposits do not there exist, owing to the fact that the invertebrate species of animals which secrete phosphatic matter in their skeletons became relatively less abundant in the middle portion of the geological section; while the vertebrate species, the birds which accumulate guanos, and the fishes which afford an abundance of bones and teeth to littoral deposits, as well as the mammalia whose skeletons occasionally form a considerable element in the later deposits, did not begin to contribute phosphatic matter to the rocks until comparatively modern times.

The absence of phosphatic deposits in the upper paleozoic and lower mesozoic strata is well shown by the fact, that, while in the carboniferous and the triassic beds there are abundant land surfaces which have been carefully explored, no phosphatic deposits of economic importance have been found in them; while on the relatively very limited areas of the tertiary and cretaceous formations, where old land areas have been explored, a large number of deposits of beds of nodular phosphate have been found.

From the facts set forth in Mr. Penrose's report and the unpublished results of certain studies on swamps, we may draw certain general conclusions as to the best method of prosecuting the search for unknown deposits of American phosphates. These conclusions are essentially as follows:—

First, as regards the superficial and recently formed deposits of phosphates. We are driven to the conclusion that this class of deposits may reasonably be sought for wherever soft calcareous beds containing a certain amount of lime phosphate have been subjected to long-continued leaching by waters containing the share of carbonic-acid gas which belongs to all rain-water after it has passed through the mat of decayed vegetation. As long ago as 1870 I became convinced that it was to the leaching-out of the carbonate of lime by the carbonated water of the soil bed that we owe in the main the concentration of the nodular phosphates of South Carolina.¹ Although it is still necessary to explain many of the details of this process to adapt it to the peculiar circumstances of particu-

¹ See Proceedings of the Boston Society of Natural History, xiii., 1871, p. 222.

lar deposits, it seems to me that it is the key to the most common forms of superficial accumulations of nodular phosphates. In an admirable description of the phosphate beds in the neighborhood of Mons, in Belgium, by Mr. F. L. Cornet,¹ that distinguished author has independently propounded this simple hypothesis, and several other writers on the subject have apprehended the importance of this leaching action.

It is evidently essential to this process of concentration that the surface of the deposits which are leaching away should have been preserved from the action of mechanical erosion, which would have prevented the formation of phosphatic concentrates.

Inquiry into the conditions of the swamp deposits of this country has satisfied me that beneath the surface of many of our fresh-water marshes, and probably in a lesser degree beneath the marine deposits of the same nature, there is a more or less important concentration of lime phosphates constantly going on. The effect of this action is seen in the remarkable fitness of these fresh-water swamp soils for the production of grain-crops. For instance: in the case of the Dismal Swamp district, in Virginia and North Carolina, we find that the soils on which the swamp deposit rests are extremely barren, while in the mud that has accumulated beneath the swamp we have a rich store of phosphates, potash, and soda, which causes the soil of these swamps to be extremely well suited to grain-tillage as soon as it is drained. In a similar way, in the swamps of New England and Elsewhere, we find the bog iron ores which are frequently accumulated in their bottoms very rich in phosphatic matter. The evidence is not yet complete that this phosphatic material becomes aggregated into nodules in the swamp muds, but the number of cases in which nodules have been found in this position makes it quite likely that the nodulation of the material may go on in that position. The present condition of the inquiry goes, in a word, to show that wherever we have a region long overlaid by swampy matter we may expect a certain concentration of lime phosphates in the lower part of the marsh deposit. Wherever the swamp area lies upon somewhat phosphatic marls which have been slowly washed away by the downward leaching of the waters charged with the acids arising from decayed vegetation, or where the swamp deposits, even when not resting on such marls, are in a position to receive the waste from beds containing phosphates, we may expect to find a considerable concentration of phosphatic matter in the swamp bed. By the erosion of these swamps we may have the nodules of phosphate concentrated in beds such as occupy the estuaries of the rivers near Charleston, S.C.

The area of swamp lands which fulfil these conditions is very large. They exist in numerous areas in more than half the so-called Southern States. At present it can only be said that they afford the conditions which, so far as the theory goes, should lead to the accumulation of phosphatic deposits of greater or less importance. It will be a simple matter to explain these deposits, though it is a task requiring a patient study of a large field. Although it is likely that the phosphatic materials will be found aggregated into nodules at many points in this area, it will not be safe to assume that they will be found in the same form as those which occur about Charleston, S.C. The nodules found in the beds about the last-named point, though in my opinion originating beneath swampy deposits, have apparently been, in part at least, swept from their original beds by the rivers which enter the sea at that point, and have thus been concentrated in estuarine deposits.

Although local concentrations of phosphatic nodules other than those now known may well be sought for in the Southern States, I do not think that the precise conditions or character of the deposits as found at Charleston should be expected to repeat themselves elsewhere. It is characteristic of the process of concentration of phosphatic as well as of other matter into nodules, that the material takes on a great variety of aspects, each proper to a particular site, and this although the surrounding circumstances of the several localities may apparently be identical.

Next lower on the geologic section we have, in the tertiary region of the Mauvaisis Terres, extensive deposits of vertebrate remains which may possibly yield some commercially important supplies of bone phosphates. Although none of the existing sources of supply

of these materials come from deposits of the nature of those found in Nebraska, the conditions of that remarkable region are so peculiar that it will not be well to pass it by without inquiry.

While the American cretaceous deposits are, as a whole, decidedly different from those of the Old World, the greensand beds of the section in the two countries present considerable likeness in their characters. It is probable that in this country, as in Europe, considerable parts of the cretaceous section are somewhat phosphatic, and that these beds containing disseminated phosphatic matter have been in many places exposed to the process of leaching in former geologic periods: therefore we may reasonably search in the cretaceous beds of this country for the same class of phosphatic deposits which have proved so important in the northern parts of Europe.

Although some peculiar deposits of phosphate have been found in the Devonian rocks of Nassau, it may safely be assumed that below the line of the cretaceous we have no facts to guide us in our search for phosphates until we come to the horizon of the upper Silurian limestones, at about the level of the uppermost beds of the upper Silurian, as far as that level can be determined by the perplexing assemblage of fossils. There occurs in Bath County, Ky., a thick bed of much decayed, very phosphatic siderite. This deposit covers but a small area, and consists of a patch of limestone of about fifteen feet thick, which has been converted into siderite by the leaching of iron-bearing waters from the ferruginous Ohio (Devonian) shales which formerly overlaid the bed. Since the escarpment of the Ohio shales retreated beyond this bed, it has been subjected to oxidation, and is now in the main converted into a much-decayed limonite. Beneath this limonite there is a greenish argillaceous sand, which contains frequent nodules of lime phosphate. These nodules are smooth-surfaced, and not unlike some of the nodules from the Carolina district. They contain as much as 92 per cent of lime phosphate. It seems likely that these nodules were formed by the leaching-out of the lime phosphate from the overlying ferruginous layers, which has completely removed the lime carbonate, but has not removed the whole of the less soluble lime phosphate.

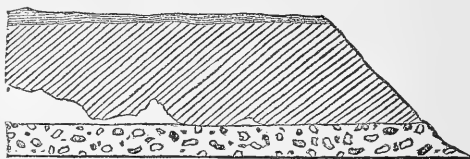

SECTION AT OLYMPIA, BATH COUNTY, KY. (PRESTON ORE BED).

Although this deposit of nodules is not of sufficient abundance to have any economic value, it is clear that we have in it an indication of a method where, by a slight variation of the conditions, important beds of nodular phosphates might be found.

In the horizons of the Cambro-Silurian section, or, as it is generally called, the lower Silurian, there is much greater reason to expect the occurrence of workable phosphates than in the beds immediately above. It is likely that the most important of the Spanish deposits belong in strata of this period, and the Welsh deposits of this general age are of noteworthy extent. We know, moreover, that the commoner marine animals of this part of the geologic section were particularly adapted for the secretion of lime phosphate.

The search of this portion of the section for phosphates should be directed to two ends: first, to finding beds of very phosphatic limestone; and, second, to discovering veins formed by a segregation of lime phosphates either in the form of the Spanish deposits referred to by Dr. Penrose or in the condition of nodular accumulations. The area of rocks of these lower Silurian and Cambrian periods in this country is very extensive, and so far there has been no search of them for phosphatic materials. The little work done in Kentucky during the above-mentioned geological survey served only to show that the proportion of lime phosphate in the rocks is extremely variable, and that in certain beds it is so considerable that the ma-

¹ See Quarterly Journal of the Geological Society, London, xlii., 1886, p. 325.

terial might advantageously be used in a local way for fertilizing purposes.¹

The search for phosphatic materials in the stratified rocks demands a method of inquiry that has not yet been applied to the study of our rocks. It seems to me that the method, or rather methods, should be as follows:—

First, there should be a careful inquiry to determine the share in which the several important groups of rock-making organic forms contribute phosphatic matter to strata. This can be accomplished by carefully comparing the chemical character of particular strata with the fossils the beds contain. When this determination is made, we shall have one means of guiding our inquiries, which will surely be of great value in the search for bedded phosphates.

Second, we should have a carefully executed chemical survey of our stratified rocks. Enough can be gathered from the scattered records of chemical analysis to make it plain that certain features of the chemical character of particular beds or divisions of strata often extend laterally for great distances. This is shown in a general way by the character of the soils formed of the waste of particular horizons; for instance, the deposits of the horizon on which lies the Cincinnati group of this country and the equivalent deposits of Europe are nearly always well suited to grasses and grains, and have a great endurance to tillage. It is now desirable to take these beds which promise to afford mineral manures, and subject each stratum to analyses which shall determine the quantity of phosphoric matter, soda, and potash which they contain, so that their fitness for use as mineral manures may be ascertained.

Below the level of the Silurian and Cambrian strata, and partly in those sections where they have been much metamorphosed, lies the field of the vein phosphates. It is more than likely that in this vast thickness of rocks, with their development in this country, there are many extensive sources of this class of phosphates which await discovery. As yet no careful search has been made for such veins in any part of the United States. The regions most likely to contain such deposits are found in the central parts of the Appalachian system of mountains, especially in the section from Virginia southward; in the Archæan district of Missouri and Arkansas, and in the vast region of highly metamorphic rocks of the Cordilleran district, extending from the Rocky Mountains to the Pacific Ocean. It is true that at present the economic value of phosphatic deposits in the western part of the continent would probably be small, on account of the great cost of transportation to the seaboard districts. But the growing use of phosphatic manures in the Mississippi valley, and the rapid exhaustion of the soils of that district, will soon give commercial importance to any sources of supply of phosphates that may be found in any parts of the Cordilleras which are convenient to transportation.

A proper study of the mineral manures of this country can best be carried on by means of a well-considered co-operation between geological explorers and the experiment stations of the several States. At present the methods of using mineral phosphates are extremely costly. Not only is the material brought into the soluble condition by saturation in sulphuric acid, but it is then mingled with ammoniacal and other matter to increase its effect as a fertilizer. The result is, that although a ton of Carolina phosphate now costs but six dollars, the average price of the manufactured product to the consumer at the phosphate factories is about thirty dollars per ton. It is probable that the essential value of the phosphatic ingredients to the plants of most soils is not enhanced by this costly treatment, though an incidental but dearly purchased gain, in the case of some crops, is obtained from the ammoniacal matter. The only effect of the superphosphatizing on the phosphatic matter is to make it more immediately absorbable by the plants. If placed on the soil without any other preparation than grinding,

lime phosphate will slowly pass into a condition in which it may be absorbed by plants, while, if treated with sulphuric acid, it is, for a time at least, in a soluble state. That this treatment is not essential is well shown by the fact that the phosphatic matter derived from the rocks is brought into a condition for absorption by the ordinary process of decay in soils. Our present costly method of applying phosphates has come about through the commercial history of artificial manures, which is as follows:—

Before guanos were brought into use, the English farmers had learned that they could profitably use the phosphatic marls of their tertiary and cretaceous deposits without any artificial preparation. If guanos had not existed, it seems likely that mineral phosphates would have always been used in this way. When the Peruvian guanos came into use, they afforded a much more stimulating material than any other purchasable manures, and in a short time they established the type of commercial fertilizers. When the sources of supply of these guanos became in part exhausted, artificial compounds, formed on a basis of rock phosphates or apatites, were devised to take their place. These were made to imitate the effect of the guanos as closely as possible. Like them, they gave a quick though temporary stimulus to the soil, enabling the farmer to obtain the greater part of the return for his investment in the season following the application of the high-priced manure. Very generally the fertilizer, guano or compounded material, was applied with the seed or dibbled in the soil alongside the young plant; so that it would be immediately available in the first stages of its growth, and, what is a more important consideration, that it might take less of the substance to give the effect than if it were sown broadcast over the surface or mingled with the soil of the whole field.

In this way a habit has been established in the art of using phosphates, as well as in the composition of the material, which, like all commercial habits, is hard to overcome. The question to be determined is as to the utility of phosphates with other modes of treatment than those which are applied in the imitation guanos. At present this treatment requires the commingling of the lime phosphate with a number of costly substances. The manufacture can only be advantageously carried on at points remote from the districts where the materials are produced, and remote from the fields where they are used, so that the costs of transportation are great. The problems to be solved by the agricultural stations are as follows:—

- (1) As to the effect, immediate as well as permanent, arising from the application of ground phosphatic rock commingled with other materials on soils used for the production of different crops.
- (2) As to the degree of comminution of the material which is most advantageous. It seems possible that fine pulverizing may take the place, in a measure, of superphosphatizing.
- (3) As to the effect of mingling the powdered rock with ordinary barnyard manure, peat, and other similar substances.
- (4) As to the effect of lime phosphate used alone on soils containing different mineral constituents; as, for instance, those having considerable proportions of lime carbonate, and those having but little of that substance.
- (5) As to the proportion of the lime phosphate which it is necessary to apply in order to produce different degrees of effect upon the fertility of soils.

It is desirable that these and other experiments should be tried at a number of stations in different parts of the country, in order that the needs of various crops may be considered, and the effect of the fertilizers on different classes of soils ascertained.

The effect of a small amount of lime phosphate on the fertility of the soil is clearly great; but, so far, we do not know with accuracy the amount necessary to produce a given effect. The range in phosphoric-acid contents in the soils of Kentucky, as determined from many hundred analyses, varies from 0.540 to 0.061.¹ In most cases the fitness of the soil for grain-tillage is measurably proportionate to the phosphatic contents. It seems almost certain, though not yet demonstrated, that the greater part of the phosphatic matter in the soil is in the state known as insoluble and that it only becomes in small part, year by year, soluble, or, in other words, fitted for assimilation by plants. Whenever the soil

¹ Among the analyses recently made by the chemists of the Kentucky geological survey is one which indicates the presence of phosphoric acid in considerable quantities in the limestones of Cretaceous age exposed at Stewart's mill, on Lulbegrund Creek, in Clark County. This partial analysis, for which I am indebted to Mr. John R. Proctor, the present director of the Kentucky survey, is as follows: viz.,—

Lime carbonate	21.380
Magnesia	3.055
Phosphoric acid	9.710
Potash	.830
Soda	.228
Silicious nodules insoluble in acids	27.580

¹ See report of Dr. Robert Peter in Reports of Geological Survey of Kentucky, new series, vol. v. 1876.

contains the quantity of lime which characterizes the better class of Kentucky soils, it is supposed, that, even if soluble phosphatic manures are applied, the superphosphate becomes again insoluble by taking up a molecule of lime. It is therefore an interesting question as to the means by which the lime phosphate enters the plants. It may be that the solution is effected through the action of the various humic acids of the soil, or it may arise from some specific change which takes place at the contact of the soil with the roots. It is evident that this point requires precise determination, for on it will depend further experiments as to the methods of applying phosphatic manures.

There is yet another point on which we need experiments. Many of our rock phosphates, especially those which are distinctly bedded, contain low percentages of phosphatic matter. Many of our lime phosphates contain crystals of apatite and calcite so intermingled that it is not possible to separate them; yet from these deposits it will be easy to produce a mixture of lime carbonate and lime phosphate containing from 10 to 20 per cent of phosphoric acid. The value of such material for manure has never been determined. If it can be used in a way which will give to the fields the full value for both the lime and the phosphorus, it will open a way for an extensive production of cheap fertilizers.

The foregoing considerations give the general results of the preliminary inquiry into phosphatic manures, of which Dr. Penrose's work forms a part. Before we go further into these studies, I much desire to have the criticism and advice of others who have considered this subject. It is with this view that I have ventured to give in the foregoing pages an account of the aim of the inquiries I have in hand. The questions are at once chemical and geological, and demand much co-operation for their solution. Much of the work of searching for the unknown phosphatic deposits of this country will necessarily have to be undertaken by local students of geology or by commercial explorers in search of such deposits. Unfortunately, the unfamiliar aspect of the various forms of phosphatic deposits will make this task under any circumstances difficult. There is no substance of equally wide diffusion among those of considerable commercial importance, which, in the present state of popular knowledge, so readily escapes detection as lime phosphate.

BOOK-REVIEWS.

Social Progress. By DANIEL GREENLEAF THOMPSON. London and New York, Longmans, Green, & Co. 8°. \$2.

THIS work is an inquiry into the foundations of social life and the means and methods of progress. The first part deals with the conditions of social progress; the second, with the means of promoting it. The work contains nothing that is specially new or striking, but is rather a restatement of the general principles of free government and social improvement as viewed from the standpoint of an evolutionist. The author's style is clear and flowing, so that the book is easy and agreeable to read; and there is much in it that thinkers of all schools will agree with. Mr. Thompson begins with a discussion of liberty and law, which he declares to be inseparable. All men, he maintains, must have equal rights and equal protection under the law; but as men and classes differ in power, the maintenance of equal rights has always been difficult. In former times the difficulty arose chiefly from military ambition and priestcraft, while in our time the danger that threatens us is that of a plutocracy. The main defect in this portion of Mr. Thompson's work is its inadequate recognition of the moral element in society. He does indeed recognize it, but he gives an altogether insufficient account of it. He bases society on self-interest alone, and reduces even benevolence itself to selfish prudence. He inquires why it is that we take pleasure in promoting the good of others, and answers the question thus: "Upon investigation we cannot fail to be led to the conclusion that the foundation for this is the selfish consideration of how delightful it would be if everybody else besides ourselves were animated by the desire and purpose of helping instead of hurting his neighbor" (pp. 63, 64); in other words, we do good to others in order that they may do good to us. The second part of Mr. Thompson's treatise treats of radicalism and conservatism, of the need of frequent change in order that society may progress,

and of the best way of effecting such changes. It offers many interesting remarks on the need of care in the formation of opinion, on the folly of attempting political changes before the public is ready for them, and on other matters incidental to the subject. On the whole, this part of the work, though dealing with less fundamental questions than the first part, is more satisfactory.

Scientific Religion. By LEIPART OLIPIHANT. Buffalo, Charles A. Wenborne. 8°. \$2.50.

WHY the doctrine taught in this book should be called scientific we do not know, for its characteristics are all of the opposite kind. Mr. Oliphant sees, as most other men do, that the old religious views will no longer suffice, and he undertakes in these pages to furnish a substitute. He believes in communication with departed spirits, who will teach us many important truths and render us invaluable aid if we will but listen to them. He holds that "the unseen world teems with intelligences, whose action upon this one is very direct, and is governed by laws." "This," he declares, "is a fact of my own personal experience." Spirit, he maintains, is only a higher form of matter, and the spirits in the unseen world communicate with us by the "interlocking of atoms." It is sad to learn, however, that the unseen spirits are not all good, and that the bad ones exert a baneful influence upon us, some of our worst impulses being due to their "infestation." Insanity, also, is due to them; and "when, therefore, we read in the Gospels of the cures by Christ of men possessed by devils, the expression is literally accurate." It depends on us, however, whether we will be influenced by the good spirits or the bad ones; and, in order to obtain the highest favors from the spirit world, we must become "bisexual." Adam, we learn, before the fall, was bisexual, and though his feminine part was separable from the masculine, the two were still one, this being possible in the case of Adam and Eve because their atomic structure was "four-dimensional." Christ, also, was bisexual, and, in fact, came into the world to restore the bisexual principle. Such is the stuff that Mr. Oliphant offers us as a new religion, and he expects men to abandon the Christianity of the churches for this! A large part of his book is devoted to a mystical interpretation of the Bible, and the rest is mainly occupied with the doctrine of spirits. We regard the appearance of this work and others of a similar character as one of the strangest signs of the times, and as indicative of a mental aberration that is truly amazing.

German Commercial Correspondence. By JOSEPH T. DANN. London and New York, Longmans, Green, & Co. 16°. 80 cents.

THIS book is of the *multum in parvo* kind, containing a great deal in a small compass. Its author was at one time assistant master in University College School in London, and it is intended not only for the use of schools and classes, but also for self-tuition. Specimens of letters are given for translation from German into English and from English into German. Copious notes, sufficient to enable the student to understand and render every idiom, are supplied, being placed at the end of the book, so that students may learn them by heart before translation is attempted. At the end of each section, subjects for writing letters similar to those contained therein are given, by way of exercises, so as to enable students to turn the study of the section itself to account. Copious vocabularies, German-English and English-German, are appended, embodying all the words which the student cannot be expected to have acquired in an elementary training. The idioms and peculiarities of the language have received special attention, so that the student may know not only what to do, but what to avoid.

French Commercial Correspondence. By ELPHEGE JANAU. London and New York, Longmans, Green, & Co. 16°. 80 cents.

THIS and its companion, the "German Commercial Correspondence," mentioned above, are constructed on such a plan that they may be used separately or together. The substance of the letters, in French or German, forming the first part of each section, is the same, and the English letters forming the second part are identical in the two volumes. In the third part are subjects for letters,

giving the student an opportunity to turn to account the study of the preceding two parts, and to acquire a greater command over the language and more self-confidence than by the process of mere translation. Like its fellow-volume in German, this contains a copious double vocabulary.

Elements of Plane Analytic Geometry. By JOHN D. RUNKLE. Boston, Ginn & Co. 8°. \$2.

THE author of this work is Walker professor of mathematics in the Massachusetts Institute of Technology at Boston, and the matter composing the first eight chapters of the book has been used by the students of that institute for some few years. The needs of the students have not been lost sight of in the preparation of the book. Though it is necessary that they should become reasonably familiar with the more elementary and fundamental parts of the subject, still the time which they can devote to it is limited. Therefore the earlier chapters are treated with somewhat more fulness than is usual in books of the kind, and particular care has been taken to illustrate and enforce all parts of the subject by a large number of numerical applications. Only the simpler problems have been selected; and an effort has been made to have the number of problems proportioned to the time which the students can profitably devote to them. The latter part of the book is based on a treatise upon conic sections by Charles Smith, M.A., of Cambridge, England, the later chapters following Mr. Smith's work quite closely. Teachers and students besides those in the Institute of Technology will find Professor Runkle's book adapted to their needs.

The Beginner's Reading Book. By EBEN H. DAVIS. Philadelphia, Lippincott. 12°. 42 cents.

THIS little book contains a series of elementary lessons for youngest readers, with appropriate pictorial illustrations, and in these respects it does not differ essentially from other works of a similar kind. But the author has a theory about the best method of teaching children to read, and he explains his method in an introduction. He begins his instructions by talking with his pupils about the various objects provided for them, thus leading them to frame brief sentences about the objects. These sentences are then placed upon a blackboard in script letters, and the children are taught to read them; and not until some twenty weeks have been spent in this way are the pupils to take up their reading-books and begin to read print. Whether this is the best way to teach children to read, experience must decide; but it seems a roundabout process. However, there is an old saying that the shortest way across is sometimes the longest way round; and so Mr. Davis's method may, after all, be the best.

AMONG THE PUBLISHERS.

WE reproduce in this number three illustrations, "The Kitchen," "Jim," and "Canadian Grouse," from "B. C. 1887," a book of travel and adventure in British Columbia, published by Longmans, Green, & Co., and reviewed lately in these columns.

— A contest has long been waged among educators as to which is of greater practical value in education, the classics or the sciences. For many years the friends of the classics had it pretty much their own way, but of late the scientists have been putting in some strong pleas in behalf of their side of the case. The latest of these, about to be issued in book form by S. C. Griggs & Co., Chicago, is by the well-known author and scientist, Dr. Alexander Winchell, University of Michigan, and is entitled, "Shall We Teach Geology?" Few, if any, American writers are better qualified for discussing this question than Dr. Winchell. While his treatise is a special plea for teaching geology in the public schools, it is intended to cover the whole ground of contest between the sciences and the classics, and hence promises to be of great interest, not only to teachers, but to all who are interested in observing the tendencies of modern education.

— Charles Scribner's Sons have just ready "French Traits," by W. C. Brownell, an analysis of French character and French society. The method of criticism is comparative throughout, the social

customs, intellectual habits, art instincts, and moral standards of the French being brought into juxtaposition with those that prevail in the United States. They have also just ready a treatise on metaphysics, by Dr. James McCosh, entitled "First and Fundamental Truths," which is regarded by the author as the copestone of what



From "B. C. 1887," Longmans, Green, & Co. THE KITCHEN WINDERMERE STORE.

he has been able to do in philosophy, and in which he formulates and explains the fundamental law governing the associated mental exercises. Finally, they have a new and revised edition for 1889 of Thomas A. Janvier's "Mexican Guide."

— A. C. Armstrong & Son have just published three important works on the Asiatic continent,— "Through the Heart of Asia over the Pamir to India," by Gabriel Bonvalot, which has been translated



From "B. C. 1887," Longmans, Green, & Co. JIM AND THE SORREL NAG.

from the French by C. B. Pitman, and is published in two volumes, with 250 illustrations by Albert Pepin; "The Industries of Japan," by Professor J. J. Rein of the University of Bonn, which gives an account of the agriculture, mining, forestry, arts, and commerce, from travels and researches in Japan, undertaken at the cost of the Prussian Government; and a second edition of the same author's work on "Japan, Travels and Researches," which, by verdict of the London *Spectator*, will be "the standard authority in such mat-

ters" for a long time to come. The new volume in the Book-Lovers' Library is "Foreign Visitors in England, and What They have thought of Us," which makes the ninth in this series.

— The new *Atlantic* index is rapidly approaching completion.

— Houghton, Mifflin, & Co. have just issued Henry S. Dana's "History of Woodstock, Vermont."

— Lee & Shepard have just published "Essays, Religious, Social, Political," by David Atwood Wasson. The book includes an autobiographic sketch, and a biography of Mr. Wasson, by his friend and contemporary, O. B. Frothingham.

— "Franklin's Works," published by subscription at five dollars a volume, are now quoted at ten dollars each, or one hundred dollars for the set. Remarking on this, the *Critic* says, "What a pity it is, by the way, that the Putnams issued so small an edition! To think that only 600 out of 60,000,000 of free-born antimonopoly Americans can own a copy of Franklin's complete works!" We trust some day Messrs. Putnam will see their way clear to publish an abridged edition.

— G. P. Putnam's Sons have in preparation a translation, by Miss Ruth Putnam and Mr. Alexander Arbuthnot, of the "Histoire de la

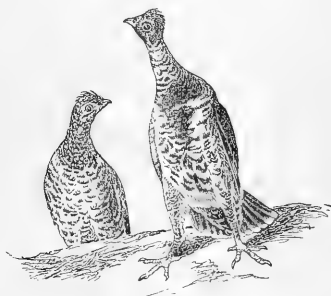

From "B.C. 1887."

Longmans, Green, & Co.

THE CANADIAN GROUSE (DENDRAGAPUS CANADENSIS).

Participation de la France à l'Établissement des États-Unis d'Amérique," by Henri Doniol. The edition will probably be a limited one. They have also in press a work by Theodore Roosevelt, on the early history of our Western territory, entitled "The Winning of the West and South-west, from the Alleghenies to the Mississippi." This is expected to be complete in two volumes, the first of which will cover the period 1769-83; that is, to the close of the Revolution.

— William Wood & Co. have recently inaugurated a new and original plan for furnishing the most recent, the most advanced, and the most authoritative writings of prominent instructors and practitioners of medical science throughout the world. They have issued the first of *Wood's Medical and Surgical Monographs*, containing three articles,—"The Pedigree of Disease," by Jonathan Hutchison; "Common Diseases of the Skin," by Robert M. Simon; and "Varieties and Treatment of Bronchitis," by Dr. Ferrand. They propose to issue one of these monographs per month, covering the details of experiments and methods which have led to the latest discoveries and newest practice. The translations from foreign languages will be intrusted to experts on the subject as well as good linguists. All that is being learned and done throughout the world will thus month by month be reported in the best manner. The first issue is one of 259 pages, and this will be the average size.

— Houghton, Mifflin, & Co. will soon publish "Home Gymnastics for the Well and the Sick," containing directions how to preserve and increase health, also how to overcome conditions of ill health by simple movements of the body, adapted to all ages and both sexes, edited by Dr. E. Angerstein, superintendent of the gymnasia of the city of Berlin, and G. Eckler, head teacher of the Royal Institution for Educating Teachers of Gymnastics, translated from the eighth German edition by Mr. Berthold Schlesinger, a well-known business-man of Boston, and amply furnished with illustrations.

— The supplement has become an important feature of *Harper's Weekly*. "American Men-of-War," by Lieut. J. D. Jerrold Kelley, U.S.N., with twenty-seven illustrations, forms the supplement to the issue of Feb. 9: that to the Feb. 16 number is devoted to an illustrated description of Omaha, Neb.

— All teachers of modern languages feel the need of varying the reading-matter used in their elementary classes. Not only do they themselves tire of going over familiar ground, but their pupils are apt to conceive a certain contempt for a language which they see represented year after year by the same two or three time-honored productions. D. C. Heath & Co. are issuing a series of texts, selected from the best writers, in inexpensive editions. To the twenty German and French texts of their list, they have just added, by purchase of C. H. Kilborn, "The Story of Ali Baba and the Forty Thieves;" "Der Zwerg Nase: Marchen von Wilhelm Hauff;" "Chamisso's Peter Schlemihl;" "Heine's Die Harzreise;" "Choix D'extraits de Daudet;" "Souvestre's Confessions d'un Ouvrier." They will add to the above this week "Jeanne D'Arc," edited by Barrère.

— Thomas L. James, postmaster-general in Garfield's cabinet, will contribute his first magazine article to the *March Scribner*, entitled "The Railway Mail Service." Thomas A. Janvier ("Ivory Black") will tell a bunch of Mexican folk-tales and superstitions collected by him during his many trips in that country. Gilberto Cano, "the best waiter at the Café Anglais," in the City of Mexico, told him many of these strange stories. The city of Treves, in Germany, founded 2004 years before Christ, and later for a century capital of the Roman Empire, will be described by Professor W. B. Scott of Princeton, who has recently made a careful study of its antiquities. Henry James will contribute the end paper, "An Animated Conversation" on international topics between Americans and Englishmen who meet in a London hotel. The paper is in dialogue form.

— In *The Home Journal* of Feb. 6 is given a selection of the poems of the late George Perry, who for many years was literary editor of that journal.

LETTERS TO THE EDITOR.

*Correspondents are requested to be as brief as possible. The writer's name is in all cases required as proof of good faith.

Twenty copies of the number containing his communication will be furnished free to any correspondent on request.

The editor will be glad to publish any queries consonant with the character of the journal.

O'Reilly's "Greenland."

MR. PILLING'S "Bibliography of the Eskimo Language" has received a bit of undeserved criticism, which I am very glad to be able to correct. An unsigned review in the *Athenæum* (Aug. 4, 1888), which is, on the whole, quite fair, and even complimentary, finds fault with Mr. Pilling for including in his bibliography O'Reilly's "Greenland," "though that work is now generally understood to have been a literary mystification." This interested me, as I had consulted the work in question, which purports to be an account of the writer's visit to Greenland in 1817, and had inserted the title in some bibliographical work of my own, not yet published.

The fact of its being a "literary mystification" did not appear to be "generally understood" in America, whatever might be the case in England. On the other hand, there appear to me to be strong internal evidence that the writer had made a visit to Greenland, and that the undoubted rubbish with which the book is filled was merely due to the ignorance and conceit of the author.

I accordingly put myself in communication with the editor of the *Athenæum*, and after a while received, in reply to my inquiries as to the history of the book, a memorandum from the reviewer, — who, however, declined to reveal his name, — as follows: —

"The person who wrote 'O'Reilly's' work on Greenland is not known. The author had probably made a voyage on board a whaler, but the greater part of the volume is simply imagination. In the *Quarterly Review* for 1818, p. 209, it is eviscerated, and the small portion which is 'not absolute nonsense' pronounced 'either fiction or downright falsehood.'"

This seemed conclusive, but I naturally turned for further corroboration to the passage in the *Quarterly Review* referred to.

Judge of my surprise when I found, on the preceding page (p. 208), the following passage, which the *Athenæum* reviewer, had evidently neglected to read when he declared that the person who wrote the book was not known:—

“Our first impression, on taking up the volume, was, that, as the subject of the Arctic regions had become one of the fashionable topics of the day . . . some hanger-on of Paternoster Row had contrived, with the help of Egede, Fabricius, and the interminable Cyclopædia of Dr. Rees, to hash up a fictitious voyage to Davis's Strait, in order to gratify the eager appetite of the public, and at the same time to 'put money in his purse.' Recollecting, however, that the log-book of the ship 'Thomas,' of Hull, in which this voyage is stated to have been made, was within our reach, we turned to it, and found that *Bernard O'Reilly, Esq., was not, as we suspected, a phantom conjured up for the occasion, but that there actually was a person of this name, in the capacity of surgeon, on board that ship*” [the Italics are mine].

The process of “evisceration” referred to by the *Athenæum* reviewer then begins with great ferocity—too great, it seems to me, even for such a ridiculous book as it is. This, however, only proves, what is easily seen from reading the book, that it is quite worthless from a scientific point of view, and evidently the work of what we should call a “crank” nowadays, not that it is not the work of the man whose name appears on the titlepage.

If the *Athenæum* reviewer has no further evidence to submit in regard to the authorship of the book, I do not see how we can doubt that the book is genuine, even though it is not authentic (which is quite another matter), and that it was perfectly proper to insert the title in a bibliography of such extended scope as Mr. Pilling's work. In fact, it would have been a mistake for Mr. Pilling to omit the book from his list, in spite of all its glaring absurdities.

JOHN MURDOCH.

Smithsonian Institution, Feb. 18.

The Soaring of Birds.

OWING to the remoteness of my present situation, I have but just seen the query of Mr. Kent. The point which he makes is a good one. I see also that I made a slight misstatement in my previous article. In the first place, as before remarked, we have the force *AB* due to the weight of the bird, and the force *AD* due to the

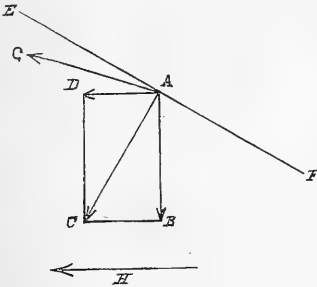

excess of velocity of the wind over the velocity of the bird. These two forces may be combined into the resultant *AC*. This resultant is resisted by the force *CA*, due to the resistance of the air acting on the wings of the bird as he wheels in circles about the point *A*. The force *CA* is therefore proportional to a function of the velocity with which the bird moves in describing these circles. The greater the velocity of the bird, the greater the force. Now, this velocity which he is capable of attaining with regard to the wind is dependent solely on the absolute velocity of the wind with regard to the earth, and can never be more than twice as great; i.e., when he is moving with the velocity of the wind and in the opposite direction.

Now let the velocity of the wind be *x*, and the excess of its velocity over the mean linear velocity of the bird (with respect to the earth) in the same direction as the wind be *a*, then the mean linear velocity of the bird with regard to the earth will be *x-a*. We will suppose that the velocity of the wind is such that *CA=AC*: the bird will therefore continue to revolve about the point *A*, which will consequently be its mean position. It must, of course, be remembered, that, while these forces are in equilibrium, the bird is slowly drifting over the earth's surface in the same direction as the wind. Its mean position would therefore describe a horizontal line with respect to the earth.

Now suppose the velocity of the wind (*x*) to increase, while its excess over that of the bird (*a*) remains the same: *AC* will therefore remain constant. But the velocity of the bird with regard to the earth (*x-a*), and also his absolute velocity with respect to the surrounding air, have increased, and therefore *CA* has increased also. Accordingly, the bird will be carried above and to the right of the point *A*. In the mean time the bird is drifting rapidly towards the left, in the direction of the wind: he will therefore describe a path lying in the same general direction as the line *AG*, *Q. E. D.*

W. H. PICKERING.

Los Angeles, Cal., Feb. 11.

A RECENT number of *Science* (xii. p. 267) gives an account of a paper by Mr. G. K. Gilbert, containing a theory of the soaring of birds, which traces this phenomenon to the advantage gained by the bird in gliding to and fro between contiguous horizontal layers of a horizontal wind, moving at different rates. The theory presented is said to have been anticipated by Lord Rayleigh (*Nature*, xxvii. p. 534); but it seems to me to rest upon what is, apparently at any rate, quite a different assumption from that which Lord Rayleigh made.

Mr. Gilbert imagines a bird gliding to windward in the lower of two contiguous layers, and traces the changes which his relative velocity will undergo if he first pass into the upper layer, then turn in it, then move to leeward, passing into the lower layer, and finally complete a cycle by turning to windward. He concludes, that, after the completion of the cycle, the bird's velocity will have increased by twice the velocity of the upper layer relative to the lower, frictional resistance being left out of account. This result he obtains by assuming, that, after turning, the bird's velocity, relative to the medium in which he turns, will be the same as before; in other words, that during the turn his velocity relative to the earth will change by an amount equal to twice the velocity, relative to the earth, of the medium in which the turn is made; the change being an increment in the turn to windward, and a decrement in the turn to leeward. Of course, in accounting for the phenomenon of soaring, some assumption must be made as to the bird's power of regulating the magnitude and direction of the force exerted upon him by the wind. But it should be a reasonable one, and, if not evidently so, should be justified. Mr. Gilbert's assumption does not seem evidently reasonable, and yet he does not even refer to its having been made.

In another recent number of *Science* (xiii. p. 31), Professor Pickering has shown that in a uniform horizontal wind the phenomenon of soaring is quite consistent with the law of the conservation of energy, provided frictional resistance is not too great, but he does not show how it may be accomplished. Lord Rayleigh, on the other hand, has stated that a uniform horizontal wind certainly cannot help us to explain this phenomenon. With so emphatic a statement from so high an authority, one is fearful of rushing in where angels fear to tread in attempting an explanation on this hypothesis. Nevertheless I venture to submit to your readers the following considerations, showing, I think, how soaring may occur in a horizontal wind which has no differential motion.

The force exerted by a horizontal wind on a bird may clearly be inclined upwards; for the wind, striking the lower surface of the wing, is deflected downwards, and must therefore have been acted upon by the wing with a downward force. The wind must therefore have exerted on the wing an upward force. What the exact direction and magnitude of this upward force will be, will depend upon the velocity of the wind relative to the bird, the wing area, and the ingenuity of the bird in adjusting its wings. With a strong wind and a wing area large relatively to the mass of the bird, it

may readily be large enough to have a vertical component equal to the bird's weight, in which case the resultant force on the bird may be horizontal.

Let us suppose, now, that a bird is at any instant moving horizontally, in the same direction as the wind, and with a small velocity relative to the earth. Since the resultant force on him may be horizontal, he may continue to move horizontally with increasing speed. As his speed increases, the velocity of the wind relative to him diminishes, and therefore also, probably, the upward force exerted on him by the wind. Although, therefore, the resultant force on the bird may have been initially horizontal, it will not remain so even for a short time. But it may remain for some time very nearly horizontal; for, as the magnitude of the relative velocity diminishes, its inclination to the normal to the plane of the wings will diminish also. During that time the bird will move slightly downwards, and his velocity will increase. When his velocity has become so great, and therefore the velocity of the wind relative to him so small, that the resultant force on him begins to have a direction differing markedly from the horizontal, let the bird wheel and steer upwards to windward. Let us suppose that in wheeling he maintains his velocity relative to the earth as well as his elevation. Then, starting upwards with a considerable velocity, he will clearly be able to rise through a certain height before his velocity has been reduced to its initial value. Let him then wheel again, and he will now be in a position to repeat the cycle with the same starting conditions as before. Whether soaring has been accomplished or not, will depend on whether or not the height gained when moving to windward is or is not greater than that lost in moving to leeward.

To determine this, consider first the downward part of the cycle. Let W_1 be the mean vertical component, and W_2 the mean horizontal component, of the force exerted by the wind on the bird's wings. Let R be the mean resistance to the relative motion of bird and air (due to friction, etc.), which in this case helps the bird. Let w be the weight of the bird, h the height through which he falls, and d the horizontal distance he traverses. Then the work done on the bird by the vertical and horizontal forces will be $(w - W_1)h$ and $(R + W_2)d$ respectively (we may treat R as a horizontal force, because the path is nearly horizontal). Let H be the energy expended immediately or ultimately in the production of heat. Then the kinetic energy gained by the bird on the downward motion will be —

$$(w - W_1)h + (R + W_2)d - H.$$

During the upward motion against the wind, the mean velocity of the wind relative to the bird will be much greater than during the downward motion with the wind; but while the direction of the relative velocity during the downward motion was upward, during the upward motion it is downward. It seems reasonable, therefore, to suppose that the upward force exerted by the wind may be made by the bird the same as before, and may have, therefore, the same components, W_1 and W_2 . Let R' be the mean resistance of the air due to friction, etc. R' , in this case, impedes the motion of the bird. Let w , as before, be the bird's weight; and let h' be the height through which he rises, and d' the distance traversed horizontally. Then the work done by the bird against the forces acting on him will be —

$$(w - W_1)h' + (R' + W_2)d'.$$

If the bird wheels when the energy expended on the upward motion is just equal to that gained on the downward motion, he will be ready to begin his second cycle under the same starting conditions as his first, and we shall have, for determining the height to which he has risen, the equation —

$$(w - W_1)h + (R + W_2)d - H = (w - W_1)h' + (R' + W_2)d',$$

from which it follows that the gain of elevation

$$h' - h = \frac{Rd - R'd' + W_2(d - d') - H}{w - W_1}.$$

Since during the upward motion against the wind the mean value of the velocity of the air relative to the bird is greater than in the

downward motion, R' will be greater than R . But the bird can so steer his course as to give his path a greater inclination to the horizon than his downward path had: hence d' may be made smaller than d ; and thus $Rd - R'd'$ may, by good steering, be made positive. Also, d' being less than d , $W_2(d - d')$ will be positive. If these two quantities together are greater than H , $h' - h$ will be positive; and if, finally, the increase of energy represented by the elevation $h' - h$ is greater than the inevitable waste during the turns, the bird will have increased his elevation during the cycle.

It seems to me possible, therefore, for a bird to soar in a uniform horizontal wind; because, by falling slowly in the motion to leeward, he allows the wind to do a large amount of work on him, and, by rising rapidly in moving to windward, he may regain his former level without having to do so much work against the wind. If it is possible, the bird's path must clearly be a spiral about a line rising in the direction of the wind, not about a vertical line; and this agrees exactly with observed fact. J. G. MACGREGOR.

Dalhousie College, Halifax, N.S., Feb. 5.

Some Habits of the Omahas.

IN the article entitled "Some Habits of the Omahas," on p. 60 of *Science* for Jan. 25, was a slip of the pen, which I wish to correct. Both Omahas and Ponkas, who speak the same dialect, call the wild honey "bee-dung." The term "bee-gum" was given me in 1872 by a Ponka, my interpreter, who stated that it was not the old name. My Omaha informant, Samuel Fremont, does not wish incorrect statements credited to him. J. OWEN DORSEY.

Takoma Park, D.C., Feb. 13.

Sawdust Explosion.

I ENCLOSE you a cutting from the *Ottawa Journal* in reference to what is called a "sawdust explosion," as it is a somewhat unique phenomenon. Last winter one occurred in the Ottawa River opposite this city, near the place referred to in this article, which broke up the thick ice over a large space. The river-channel is deep, but it is filled with a great accumulation of sawdust from the large mills just above. This sawdust generates immense quantities of marsh-gas, and once in a while something seems to start it up suddenly in large volumes. These striking the under side of the ice with great force, burst it up in the manner here described. This is why they are called "explosions." The gas is never ignited.

"Mr. J. de St. Denis Lemoine, sergeant-at-arms of the Senate, was blown up in a sawdust explosion on the Ottawa River, Saturday, Feb. 9, 1889, at midnight. He escaped with a wetting, and will not snowshoe to Gatineau Point again. It was a jolly party of gentlemen who left the city Saturday evening for a tramp on the ice-bound Ottawa. It included Messrs. Riddington, Lemoine, R. Fleming, J. Travers Lewis, J. W. Pugsley, Charles Elliott, Laurence Taylor, W. Middleton, Bogert, G. A. Henderson, and some others.

"The snowshoers headed direct to Gatineau Point, where an enjoyable time was spent. They started for home shortly before midnight. Mr. Riddington led the way, the snowshoers following in Indian file at a distance of about ten feet apart. The leader cautiously picked his way, because an ominous crackle here and there gave warning of proximity to cold waters running a few inches beneath.

"Matters went well for a time, until, some little distance below the Rideau Falls, suddenly the snowshoers were startled by a terrific explosion. An instant later they saw Mr. Lemoine hurled in the air, and as suddenly fall back into a mass of broken ice. It was only the work of a moment to grasp the sash of Mr. Lemoine and haul him on to the firm ice, not much the worse for his partial wetting. There would have been a funeral had the sergeant-at-arms been in the middle of the explosion.

"Mr. J. Travers Lewis had a narrow escape. Fortunately he stopped for a moment to fix his snowshoe-strings, and, had he continued in the footsteps of Mr. Lemoine, would also likely have experienced a sad fate.

"The snowshoers say that in their opinion the sawdust question has been solved." ROBERT BELL.

Ottawa, Can., Feb. 13.

C. & C. ELECTRIC MOTOR COMPANY.

Electric Motors
FOR
Arc and Incandescent Circuits,
Most Economical Motor
on the Market.
Regulation Perfect.
Motors Designed for all Power
Purposes.

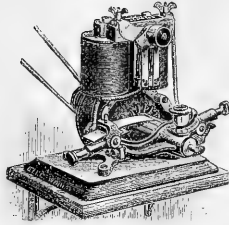

OFFICE and MANUFACTORY:
402 and 404 Greenwich St., New York City.
New England Office, 19 Pearl St., Boston.
Philadelphia Office, 301 Arch St.
Western Office, 139-141 Adams St., Chicago.
Southern Office, 25 Carondelet Street,
NEW ORLEANS.

THE

American Bell Telephone COMPANY.

95 MILK ST., BOSTON, MASS.

This Company owns the Letters Patent granted to Alexander Graham Bell, March 7th, 1876, No. 174,465, and January 30, 1877, No. 186,787.

The Transmission of Speech by all known forms of **ELECTRIC SPEAKING TELEPHONES** infringes the right secured to this Company by the above patents, and renders each individual user of telephones, not furnished by it or its licensees, responsible for such unlawful use, and all the consequences thereof and liable to suit therefor.

ESTERBROOK'S STEEL PENS.

OF SUPERIOR AND STANDARD QUALITY.

Leading Nos.: 048, 14, 130, 135, 239, 333
For Sale by all Stationers.

THE ESTERBROOK STEEL PEN CO.,

Works: Camden, N. J. 26 John St., New York.

A TEMPORARY BINDER

for Science is now ready, and will be mailed postpaid on receipt of price.

Half Morocco - 75 cents.

This binder is strong, durable and elegant, has gilt side-title, and allows the opening of the pages perfectly flat. Any number can be taken out or replaced without disturbing the others, and the papers are not mutilated for subsequent permanent binding. Filled in this binder, *Science* is always convenient for reference.



N. D. C. HODGES,

47 Lafayette Place, New York.

Scientific Apparatus.

J. GRUNOW,

631 Sixth Avenue, New York.
Established 1852.

MAKER OF

Microscope Stands,
Oil Immersion Objectives and Abbe Condensers for Bacterial and Histological work, of Objectives, Camera Lucida and other accessory apparatus.

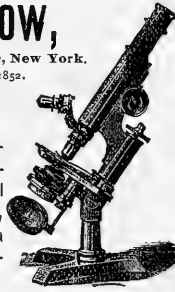

IMPROVED OIL LIGHT MAGIC LANTERNS.

Also Lime and Electric Light Apparatus, and mechanical, plain, and fine colored views.

J. B. COLT & CO., Manufacturers,
No. 16 BEERMAN STREET, NEW YORK.

MAGIC Stereopticons and the Best Views
LANTERNS for Public, Church, Home, and Scientific Exhibitions. Best apparatus, new views, Largest stock. Reduced prices. 24 Years' Practical Experience. Illus. Catalogue Free.
GEO. H. PIERCE,
136 S. Eleventh St., Philadelphia, Pa

W. H. WALMSLEY & CO.

SUCCESSORS TO

R. & J. BECK,

1016 Chestnut Street Phila

Microscopes and all Accessories and Apparatus. Photographic and Photo-Micrographic Apparatus and Outfits.

Spectacles, Eye Glasses, Opera and Marine Glasses, etc.

Illustrated Price List mailed free to any address. Mention *SCIENCE* in corresponding with us.



E. & H. T. ANTHONY & CO.
591 Broadway, N. Y.

Manufacturers and Importers of

PHOTOGRAPHIC INSTRUMENTS,

Apparatus and Supplies of every description. Sole proprietors of the Patent Detective, Fairy, Novel, and Bicycle Cameras, and the Celebrated Stanley Dry Plates.

Amateur Outfits in great variety, from \$9.00 upward. Send for Catalogue or call and examine.  More than 40 years established in this line of business.

WHITALL'S PLANISPHERES OF THE STARRY HEAVENS name and locate all Planets, Stars, and Constellations visible at any given minute of time. Every one should possess set, \$5.00; Miniature, 30 cents postage paid. Ask stationer, or address Wm. T. Cooper, Manager, 307 Race St., Philadelphia, Pa.

Readers of Science

Corresponding with or visiting Advertisers will confer a great favor by mentioning the paper.

Publications received at Editor's Office, Jan. 28-
Feb. 16.

ALLEN, G. Force and Energy: A Theory of Dynamics. London and New York, Longmans, Green, & Co. 161 p. 8°. \$2.25.
ARKANSAS GEOLOGICAL SURVEY, Annual Report of the, for 1887. Vol. I. Little Rock, State, 320 p. 8°.
CORNELL University, College of Agriculture. First Annual Report of the Agricultural Experiment Station, Ithaca, N. Y. Ithaca, The University. 61 p. 8°.
COUES, E. Signs of the Times: From the Standpoint of a Scientist. Chicago, Religio-Philosophical Publ. House. 44 p. 12°.
DARN, J. T. German Commercial Correspondence. London and New York, Longmans, Green, & Co. 238 p. 16°. 80 cents.
DAVIS, E. H. The Beginner's Reading-Book. Philadelphia: Lippincott, 123 p. 12°. 42 cents.
DINÁMICA, La. Vol. I. No. 1. New York, De Castro y Delgado. 16 p. 4°. \$1 per year; 15 cents single number.
ELECTRIC Power. Vol. I. No. 1. New York, Electr.

Power Publ. Co. 24 p. 4°. \$3 per year; single number, 25 cents.
ERDE, Die. Lief. 46-50. Leipzig, Hartleben. f°.
GIBSON, R. J. H. A Text-Book of Elementary Biology. London and New York, Longmans, Green, & Co. 369 p. 16°. \$1.75.
INTERPRETOR. Vol. I. No. 1. Leipzig, Franckenstein & Wagner. 8 p. f°.
JANAU, E. French Commercial Correspondence. London and New York, Longmans, Green, & Co. 222 p. 16°. 80 cents.
JEFFERIES, R. Field and Hederow. London and New York, Longmans, Green, & Co. 331 p. 12°. \$1.75.
KLEIN, H. J. Star Atlas. Tr. by E. McClure. London, Soc. for promoting Christ. Knowl.; New York, E. & J. B. Young & Co. 72 p. 18 maps. 4°.
OHIO Agricultural Experiment Station, Sixth Annual Report of the, for 1887. Columbus, State. 338 p. 8°.
OLIPHANT, L. Scientific Religion. Buffalo, C. A. Wendt. 473 p. 8°. \$2.50.
THOMPSON, D. G. Social Progress. London and New York, Longmans, Green, & Co. 166 p. 8°. \$2.
WIGMORE, J. H. The Australian Ballot System. Boston, C. C. Soule. 155 p. 8°. \$1.

Arnold,
Constable & Co.
"Anderson's"
CELEBRATED
ZEPHYRS.
"Freres Koechlin's"
PRINTED SATEENS.

Special and attractive patterns
and coloring in these famous fabri-
cs, unrivalled for wear.

Broadway & 19th St.
New York.

ESTABLISHED 1859.

H. A. DREW,
Commercial Printer,
5 Clinton Place, near Broadway,
New York.

Wedding Orders, Souvenirs, Invitations, Or-
ders of Dance, etc., etc., done in the latest and
most elaborate styles, at reasonable prices.
All Favors promptly attended to.

SILKS FOR TENNIS WEAR.

The Novelty this Spring for Lad-
ies' and Misses' Tennis Suits and
for Gentlemen's Tennis Shirts is a
silk fabric that can be washed
without injury to fabric or color.
This silk is made 24 and 32 inches
wide, in plain colors, in delicate
stripes and checks, \$1 and \$1.50
per yard.

For such as prefer woolen materi-
als we also have several lines of
the finest Scotch and French Flan-
nels from 35 to 60 cents per yard.

JAMES MCCREERY & CO.

BROADWAY AND ELEVENTH ST.,
NEW YORK CITY.

THE GREAT AMERICAN
TEA
COMPANY
**GOOD NEWS
TO LADIES.**
Greatest inducements ever offer-
ed. Now's your time to get
up orders for our celebrated
Teas and Coffees, and secure
a beautiful Gold Band or Moss
Rose China Tea Set, Dinner Set,
Gold Band Moss Rose Toilet Set, Watch, Brass Lamp,
or Whisker's Dictionary. For all particulars address
THE GREAT AMERICAN TEA CO.,
P. O. Box 289. St. and 83 Vesey St., New York.

THE CHEAPEST AND BEST
PHOTO ENGRAVING CO.
No. 67 PARK PLACE, NEW YORK
ENGRAVING FOR ALL ILLUSTRATIVE AND
ADVERTISING PURPOSES.

Brokers and Auctioneers.

R. ELLIS & CO.

BUSINESS, HOTEL AND PATENT BROKERS,
AUCTIONEERS, ETC.

No. 176 BROADWAY,

Room 46.

New York.

CLIENTS Advised free of charge.

J. P. TRAVER & CO.,
General Auctioneers,
Real Estate and Business Brokers,
OFFICE, 23 PARK ROW,

OPPOSITE POST OFFICE, (Rooms 14 & 15.) New York.

Mortgages Foreclosed. Cash Advanced on Consignments.

Property of Every Description Bought, Sold
and Exchanged.



KIMBALL'S
STRAIGHT CUT
CIGARETTES.

Unsurpassed in quality.
Used by people of refined taste.
Highest award at Brussels, 1888.
The finest smoking mixtures are of
our manufacture.
Fifteen First Prize Medals.
WM. S. KIMBALL & CO.
Rochester, N. Y.

Sprague Electric Railway and Motor Company.

For Stationary or Railway Work,
for Mining or Engineering
operations the SPRAGUE MOTORS
are unexcelled.

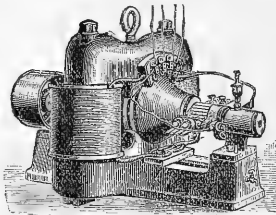

Estimates given for complete
Power Installations.
Send for Circulars and full
Information.

16 and 18 BROAD STREET, NEW YORK.

ELECTRICAL TESTING BUREAU,

Johns Hopkins University, Baltimore, Md.
Resistance Coils and Boxes Compared.
Am meters and Volt meters calibrated.
Condensers standardized.
Primary and Secondary Batteries Tested.
Efficiency of Dynamos and Motors Deter-
mined.
Insulation of Cables and Wires Tested.
Etc., Etc.
Circulars describing Methods Used, Prices,
Etc., sent on Application.
Address as above.

Insurance.

DELAY IS DANGEROUS.

We call attention to the new form of Accident (indem-
nity) Insurance policies, which are written by the Mer-
chant's Casualty Insurance Association, 21 Park Row,
New York City. John S. Purdy, Secretary. These policies
cover weekly allowances of from \$10 to \$25, according to
occupation, at a cost of only \$6 a year exclusive of the
cost to join, which is \$5 payable once only. The public,
as a rule, carry life insurance, and the ordinary accident
policies issued by companies, paying a sum in case of
death, is not so desirable as one of these indemnity policies
in case of accidents, which are so plentiful in this fast age
with its railroad horrors, fast driving, electric wires, and
other countless forms of danger to which the public is con-
stantly exposed. The fact of the Association having no
unpaid claims, and its having just passed an examination
by the Insurance Department of New York State, shows
that the management is liberal with its policy-holders
and conservative in its action. The Association also des-
ires to secure energetic Agents in every village and town,
to whom territory and favorable terms will be given.

TO EMPLOYERS.

Having purchased the fixtures, good will, &c., of
the NEW YORK EMPLOYMENT BUREAU, at No. 681
BROADWAY, in this city, we request the patron-
age of the public in the future. We desire to
fill a long-felt want for an employment bureau,
where only the best grade of male help is dealt in,
and it is our aim to send ONLY such help as is or-
dered in every instance, and our patrons can rely
on us to send strictly first-class help, the references
of whom we personally investigate before sending to
any one. We simply request a trial, and are con-
vinced that we will give satisfaction in every case.
We have on hand help in every branch, which we
can send upon receipt of telegram or letter, AND
FOR WHICH WE MAKE NO CHARGE TO AN EMPLOYER.

NEW YORK EMPLOYMENT BUREAU,
(AS REORGANIZED).



SCIENCE

SEVENTH YEAR.
VOL. XIII. No. 317.

NEW YORK, MARCH 1, 1889.

SINGLE COPIES, TEN CENTS.
\$3.50 PER YEAR, IN ADVANCE.

A Canvasser wanted, on Salary and Commission, to solicit subscriptions for "Science."

Scientific Apparatus.

J. GRUNOW,

621 Sixth Avenue, New York.
Established 1832.

MAKER OF

Microscope Stands, Oil Immersion Objectives and Abbe Condensers for Bacterial and Histological work, of Objectives, Camera Lucida and other accessory apparatus.



WHITALL'S PLANISPHERES OF THE STARRY HEAVENS name and locate all Planets, Stars, and Constellations visible at any given minute of time. Every one should possess set, \$5.00; Miniature, 30 cents postage paid. Ask stationer, or address Wm. T. Cooper, Manager, 307 Race St., Philadelphia, Pa.

W. H. WALMSLEY & CO. SUCCESSORS TO

R. & J. BECK,

1016 Chestnut Street Phila
Microscopes and all Accessories and Apparatus. Photographic and Photo-Micrographic Apparatus and Outfits.

Spectacles, Eye Glasses, Opera and Marine Glasses, etc. Illustrated Price List mailed free to any address. Mention SCIENCE in corresponding with us.



IMPROVED OIL LIGHT

MAGIC LANTERNS.

Also Lime and Electric Light Apparatus, and mechanical, plain, and fine colored views.

J. B. COLT & CO., Manufacturers,
No. 16 BEEKMAN STREET, NEW YORK.

MAGIC LANTERNS

Largest stock. Reduced prices. 24 Years' Practical Experience. Illus. Catalogue Free.

Stereopticons and the Best Views for Public, Church, Home, and Scientific Exhibitions. Best apparatus, new views. Largest stock. Reduced prices. 24 Years' Practical Experience. Illus. Catalogue Free.

GEO. H. PIERCE,

136 S. Eleventh St., Philadelphia, Pa



E. & H. T. ANTHONY & CO. 591 Broadway, N.Y.

Manufacturers and Importers of

PHOTOGRAPHIC INSTRUMENTS,

Apparatus and Supplies of every description. Sole proprietors of the Patent Detective, Fairy, Novel, and Bicycle Cameras, and the Celebrated Stanley Dry Plates.

Amateur Outfits in great variety, from \$3.00 upward. Send for Catalogue or call and examine. More than 40 years established in this line of business.

A Canvasser wanted, on Salary and Commission, to solicit subscriptions for "Science."

MACMILLAN & CO.'S NEW BOOKS.

A NEW BOOK BY THE AUTHOR OF "HEREDITARY GENIUS."

NATURAL INHERITANCE. By Francis Galton, author of "English Men of Science, their Nature and Nurture," "Inquiries into Human Faculty and its Development." 8vo, \$2.50.

A HISTORY OF EIGHTEENTH CENTURY LITERATURE 1660-1780. By Edmund Gosse, M.A., Clark Lecturer in English literature at Trinity College, Cambridge. 12mo. Library Edition \$1.75; Student's Edition \$1.

"In fact, Eighteenth Century Literature is far from being exclusively adapted to students. The criticisms are never tedious or dry, and the short biographies contain interesting personal details of writers, some of whom are little known. We shall be surprised if the work is not as popular with the general public as with those who may claim a special knowledge of its subject."—*London Athenaeum.*

NATURE SERIES. NEW VOLUME.

POPULAR LECTURES AND ADDRESSES. By Sir William Thomson LL.D., F.R.S., F.R.S.E., etc., Professor of Natural Philosophy in the University of Glasgow. In three volumes. Vol. I., Constitution of Matter, with illustrations. 12mo. \$2.

OCCESSIONAL ADDRESSES ON EDUCATIONAL SUBJECTS. By S. S. Laurie, A.M., LL.D., Professor of the Institutes and History of Education in the University of Edinburgh. 12mo. Cambridge University Press, \$1.25.

A TREATISE OF HUMAN NATURE. By David Hume. Reprinted from the original edition in three volumes, and edited, with an analytical index, by L. A. Selby-Bigge, M.A., Fellow and Lecturer of University College. 12mo. Oxford Clarendon Press. \$2.25.

MACMILLAN & CO. 112 Fourth Avenue, New York.

GUARANTY INVESTMENT COMPANY

CAPITAL \$250,000.

Offices: Atchison, Kan. 191 Broadway, New York, 222 Walnut St., Phila.

Hon. ALBERT H. HORTON (Chief Justice, Kansas Supreme Court), Topeka, Kan., Pres't.

7% Guaranteed Farm Mortgages 7%

The Guaranty Investment Company makes loans upon fertile farms in the choicest portions of Kansas and Nebraska and has adopted the policy of sending a Committee of its Investors each year to examine its loans and methods of business.

The Committee this year consisted of PROF. A. H. BERLIN, Principal of the High School Montrose, Pa., and MAJ. THEODORE L. POOLE, Ex-U. S. Pension Agent, Syracuse, N. Y. Both of these gentlemen are persons of the highest character and have the confidence of the Communities in which they reside.

The Committee has recently returned and has made a very interesting Report upon the general development of Kansas and Nebraska as well as the business of the Company. The Company will be glad to send this Report to any address.

The following names are taken from the long list of Investors in our Mortgages:

(See if Some Friend of Yours is not in the List.)

William A. Cauldwell, 59 Liberty St., N.Y.
 Palmer Cox, 688 Broadway, N.Y.
 Rev. Jos. B. Rylance, D.D., 11 Livingston Place, N.Y.
 Rev. Brady E. Backus, D.D., 750 West 38th St., N.Y.
 Rev. R. M. Sommerville, 126 West 43d St., N.Y.
 Dr. Robert A. Murray, 234 West 32d St., N.Y.
 Dr. James P. Tuttle, 136 West 41st St., N.Y.
 H. Edwards Kowland, 215 Fulton St., N.Y.
 Irving H. Tift, Esq., 271 Broadway, N.Y.
 Prof. D. G. Eaton, 55 Pineapple St., Brooklyn, N.Y.
 Dr. F. P. Thwing, 156 St. Marks Ave., Brooklyn, N.Y.
 Dr. C. C. Miles, Greenport, N.Y.
 John V. N. Bergen, Fort Jefferson, N.Y.
 Benj. W. Stilwell, Yonkers, N.Y.

R. C. Coleman, Goshen, N.Y.
 Mrs. Samuel Carlisle, Newburg, N.Y.
 Dr. C. C. Bartholomew, Ogdensburg, N.Y.
 Rev. Nelson Millard, D.D., Rochester, N.Y.
 Rev. Horace G. Hinsdale, D.D., Princeton, N.J.
 Dr. Charles M. Howe, Passaic, N.J.
 George A. Skinner, 5 Railroad Place, Newark, N.J.
 Dr. Edwin M. Howe, 85 Halsey St., Newark, N.J.
 Dr. H. G. Buckingham, Clayton, N.J.
 Dr. Martin Cole, Jr., Hainesville, N.J.
 Mortgage Trust Co., 01 Pa., Philadelphia, Pa.
 Miss Mary Miller, 1230 Spruce St., Philadelphia, Pa.
 Henry D. Biddle, 312 1/2 Walnut St., Philadelphia, Pa.

Dr. Calvin C. Halsey, Montrose, Pa.
 Rev. William Baldwin, Great Bend, Pa.
 Gen. William Lilly, Mauch Chunk, Pa.
 Second Nat. Bank, Mauch Chunk, Pa.
 Enos E. Thatcher, West Chester, Pa.
 Mrs. Townsend Poore, Scranton, Pa.
 Rev. Burdett Hart, D.D., New Haven, Conn.
 Dr. Frank H. Wheeler, New Haven, Conn.
 Charles R. Christy, Stamford, Conn.
 Mrs. Catharine P. Fuller, Woodmont, Conn.
 Miss Jessie Henderson, Lenox, Mass.
 Dr. M. J. Halloran, Worcester, Mass.
 Albert Walker, Bennington, Vt.

Address for Report and Monthly Bulletin

HENRY A. RILEY, General Eastern Manager, 191 Broadway, N.Y.

THE CHEQUE BANK LIMITED.

ESTABLISHED IN LONDON, 1873.

CHIEF OFFICE, 4 Waterloo Place, Pall Mall, London.

TRUSTEES:

The Right Honorable JOHN BRIGHT, M.P.
 The Right Honorable EARL BEAUCAMP.

Bankers: Bank of England.

The Capital of the Bank and its Guarantee Fund of 50% is invested in Government Securities.
 The Bank does not discount Notes or Bills, nor speculate, but loans its Deposits against Government Securities, thus making the Cheque Bank Cheques EQUAL TO CASH—as Bank of England Notes are.

The Cheque Bank issues Cheques singly or in books from ONE POUND upwards, for the use of Travellers, and for others remitting money to Europe, available in every town in England, Scotland, Ireland, and Wales. In every town of Europe, and in all other parts of the world.

Cheque Bank Cheques are accepted as Cash by all the British Government Offices.

VISITORS TO THE PARIS EXHIBITION this summer can get the Cheque Bank Cheques cashed at 50 Banking Houses in Paris.

Travellers and others holding Cheque Bank Cheques can have their mail matter addressed to them, care of the Cheque Bank, London, who will take charge of the same and forward to any address.

For Hand-Book containing List of upwards of 2000 of the principal Banking Houses throughout the World who Cash the Cheque Bank Cheques, and for all information, apply to the AGENCY.

CHEQUE BANK, Limited,
 UNITED BANK BUILDING,
 2 Wall St., New York.

E. J. Mathews & Co., Agents.

REFERENCES BY TELEPHONE:

JNO. W. MACKAY, Esq., President Commercial Cable Company, Mackay-Bennett Cables, New York.
 F. O. FRENCH, Esq., President Manhattan Trust Co., New York, and others.

KNABE

PIANOFORTES.

UNEQUALLED IN

Tone, Touch, Workmanship and Durability.

WILLIAM KNABE & CO.
 NEW YORK: No. 112 Fifth Av., above 16th St.
 BALTIMORE: Nos. 22 and 24 E. Baltimore St.
 WASHINGTON: No. 817 Market Space, Penn. Av., near 9th St.

SCHOOLS AND COLLEGES

will have a positive advantage by ordering their furniture apparatus and supplies from C. PARDO & CO.,
 31 East 17th St., New York.

Wants.

A YOUNG MAN can have lucrative engagements, not only a fixed salary, but according to his work accomplished in travelling for SCIENCE. A personal interview invited.
 N. D. C. HODGES,
 47 Lafayette Place, New York.

Old and Rare Books.

A. S. CLARK, Bookseller,

34 PARK ROW, NEW YORK CITY.

A Gleaner in the By-ways of Literature. Results of Gleaning found in Catalogues issued from time to time.

CATALOGUE NO. 27 NOW READY.

BACK NUMBERS and complete sets of leading Magazines. *Refers to.* AM. MAG. EXCHANGE, Schoharie, N.Y.

H. WILLIAMS,

Dealer in Old Magazines, Reviews, &c. Scientific periodicals a speciality. 39 Macdougall St., N.Y.

FOOD ADULTERATION

And its Detection. With photomicrographic plates and a bibliographical appendix. By J. P. Battershall, 328 pages, 8vo, cloth. Price, \$3.50. Circulars and Catalogues on application. E. & F. N. SPON,
 12 Cortlandt St., New York.

Scott's EMULSION OF Pure Cod-Liver Oil AND HYPOPHOSPHITES ALMOST AS PALATABLE AS MILK. So disguised that the most delicate stomach can take it. Remarkable as a FLESH PRODUCER. Persons gain rapidly while taking it.

SCOTT'S EMULSION
 Is acknowledged by Physicians to be the FINEST and BEST preparation of its class for the relief of CONSUMPTION, SCROFULA, GENERAL DEBILITY, WASTING DISEASES OF CHILDREN, and CHRONIC COUGHS. ALL DRUGGISTS. Scott & Bowne, New York.

SCIENCE

FRIDAY, MARCH 1, 1889.

THE ELECTRIC MOTOR IN FACTORIES.

ON Feb. 6 a visit was made to the factory of the C. & C. Electric Motor Company by the New York Electrical Society, accompanied by some of the members of the American Institute of Electrical

fact that each machine individually is in operation only for a short time, even in the busiest times of work, the sum total of the power consumed at any one time is but a fraction of that required to drive all the machines simultaneously.

Fig. 2, for which we are indebted to the *Electrical World*, gives the ampères delivered by the dynamo during the whole run of the factory for one day, the diagram shown being one selected from a

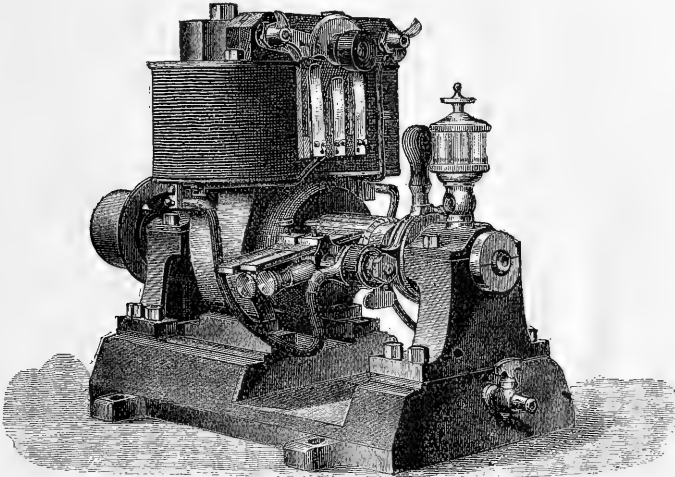

FIG. 1.—NEW TYPE OF C. & C. MOTOR.

Engineers. The arrangements for power transmission were explained by Mr. Harvey L. Lufkin, of the company.

The engine in the engine-room is belted direct to a 50,000 watt Edison compound wound dynamo, which furnishes light to the building, as well as the current for driving the motors connected with the shafting. Instead of belting from floor to floor, wires run up, connecting directly with motors suspended from the ceilings.

number which did not differ materially in outline, so that an average run is there illustrated. As will be seen, the electrical horse-power delivered by the dynamo even with the heaviest load, due in great measure to the current furnished to the incandescent lamps, never exceeded 18 horse-power; and at times of the day when little light was in demand, such as between 10 and 3 o'clock, the load averaged no more than 12 horse-power.

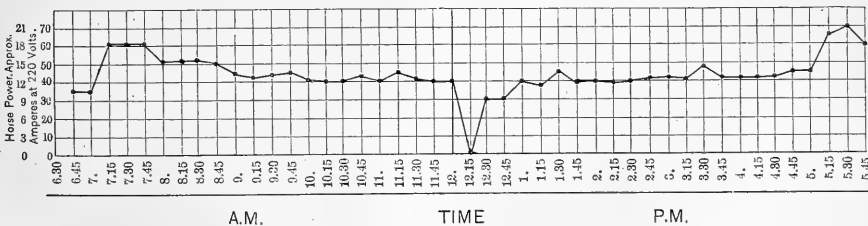

FIG. 2.—DIAGRAM OF CURRENT-DELIVERY.

On the floor working the heavy machinery, such as lathes, planers, drill-presses, milling-machines, on which are some thirty machines, four motors, connected to separate lines of shafting, do the work. Two of these are only of 3.5 horse-power, and two of 1 horse-power each. The small amount of power required is remarkable.

To one looking at the shop in operation, it seems hardly credible that machines of such small power should be capable of doing the work which is actually accomplished; but when we consider the

The average load on the dynamo is about 40 ampères, or about 12 electrical horse-power, which covers both light and power. The friction load on the engine is 6.4 horse-power, giving us a total of about 20 to 22 horse-power on the engine. The power which would be required to operate the factory in the usual way, by belting through the floors, was estimated to be between 30 and 50 horse-power, without considering the power required for lights, amounting to an additional 15 horse-power.

Every operator in the factory who has charge of a machine, be it a milling-machine or drill-press, a lathe or planer, has a certain and absolute direct and instantaneous control over the automatic valve-gear on the engine in the basement, through the medium of the belt-shifter on his machine. Suppose he is using a milling-machine. The piece being milled has finished its travel, and the machine is stopped by shifting the belt on to a loose pulley. A horse-power of duty has been taken off of the electric motor driving that machine: the tension on the motor belt relaxes to exactly that extent; the counter electro motive force in the armature of the motor instantly increases; and the horse-power of current, which is no longer called for in the motor, the dynamo in the engine-room ceases to generate; and the automatic valve-gear on the engine immediately adjusts itself to a shorter cut-off.

Another great feature in this method of factory construction is the independence of each department. A break-down in one, or a stoppage from any cause, has no effect on the other departments. Each floor is connected directly to the engine-room.

The accompanying illustration (Fig. 1) shows the improved form of motor now manufactured by the company. The motor is wound for 110 volt constant potential circuits, and is started by simply turning on the switch fastened to the front of the yoke, and stopped by turning it back again. The mechanical construction of these motors is excellent, the machine being interchangeable in every part. Every hole in each part of the machine is so drilled, even in the large bed-plate, that it is impossible for the workman to get a hole a hundredth of an inch out of the way; so that, when the machines are assembled, it is only necessary to take each piece indiscriminately out of a pile of finished parts, and bolt them together.

CONVENTION OF THE NATIONAL ELECTRIC LIGHT ASSOCIATION.

The ninth semi-annual convention of the National Electric Light Association was held at the Exposition building, Chicago, Feb. 19-21. The attendance was large, the electric light and power interests of all parts of the country being well represented. A large number of electrical exhibits, including all kinds of electric light and motor apparatus, from insulating tape to an electric street-car in operation, added much to the interest and importance of the occasion. The building was, as might naturally be expected, handsomely decorated, and brilliantly illuminated, when necessary, by numerous constellations of incandescent lamps, many of them being effectively grouped in ornamental designs.

On Tuesday, the 19th, the convention was called to order by the president of the association, S. A. Duncan, who introduced the city electrician, Professor Barrett, representing the mayor of the city, who was unavoidably absent. It may be mentioned here, incidentally, that a city electrician is an official undreamed of until recently, when electric light and power matters have assumed an importance approaching that of the water-supply or public works department.

After the usual courtesies of the city had been extended to the members of the association by Professor Barrett in the name of the mayor, President Duncan, after duly acknowledging the hospitalities tendered by the authorities, delivered the opening address, a brief abstract of which we give. Mr. Duncan said, in effect,—

“But few of the gentlemen of this country who are commercially connected with the manufacture and distribution of electric light and power are aware that five years ago this month a handful of men met in Chicago, and organized a movement which has grown into the organization which is in session at the present time. The industry of electric lighting at that time was carried on with all the enthusiasm which comes with a new undertaking, and with the mistakes which are sure to arise in the commercial introduction of any great industrial agency. The gentlemen engaged therein, strangers to one another, working independently, with no attempt at harmony, with but little knowledge of one another's methods of business, with no established custom or precedent to guide them, came together for the purpose of deriving those benefits which invariably result from the deliberate discussion of those questions which are common to the experience of all electric-light men. To

even enumerate the topics which have been discussed at the various conventions of this association would consume more time than your president feels at liberty to take. Fortunately, the association is in possession of a complete set of published proceedings, and these volumes testify to the steady and rapid growth of the industry, and the increased information on the part of the whole electrical fraternity on the general subject of electric light and power.

“In the early days of this association the chief question was the question of arc lighting. The incandescent light had scarcely come into commercial use. No sooner had the questions involved in arc lighting been solved than the complicated questions involved in the distribution of incandescent lighting absorbed the attention of the fraternity. Following closely upon the problems involved in incandescent lighting came the question of electrical distribution of power, first for stationary motor purposes, and afterward for the purpose of electrical locomotion. This question is, perhaps, the most important one before us. To say that electrical power is not a success would be to reflect upon the scores of electrical railways in successful operation in this country, and upon the thousands of electrical motors that are commercially serving the wants of man.

“We may here profitably consider some figures indicating the growth of the electric lighting and power industry, the increase in the number of central stations, arc and incandescent lamps, electric motors and electric railways, now in operation. At the meeting of this association one year ago, it was estimated that there were not less than 4,000 central-station and isolated plants in operation in the United States: the number of central-station and isolated plants at the present time is 5,747. This shows an increase during the year of 2,067 plants, or, in other words, of 45.8 per cent. A year ago there were 175,000 arc lamps in daily use in the United States: at present there are 219,924,—an increase of 62,625, or a total gain of arc lamps for the year of 34.3 per cent. A year ago there were 1,750,000 incandescent lamps in use in the United States: at the present time there are no less than 2,504,490, making a gain of 754,990 incandescent lamps,—49 per cent increase. The increase in capitalization in electric-light companies of the United States during the year has been \$69,397,734.

“It is interesting to note some comparative figures upon the electric-railway industry. Six months ago there were 34 electric railroads in operation in the United States: during the last six months there has been an increase of 19, making at the present time a total of 53. Six months ago there were 83 roads in process of construction: there are 39 less at the present time, making the number of roads now under construction, not finished, 44. Six months ago there were 39 electric roads incorporated in the United States upon which construction had not yet begun: at the present time there are 42. Six months ago there were 225 electric cars in operation: since that time, 155 have been put into commission, making, at the present time, 379 cars in operation. Six months ago there were 244 cars under contract, but not in operation: this number has increased by 185 during the last six months, making a total of 339 electric cars at present under contract, but not running. Six months ago there were 138 miles of single track in operation: during the past six months there has been an increase of 157.5 miles, making a total at the present time of 294.5 miles of single track in operation. Six months ago there were 189.5 miles of single track under contract, but not in operation: at the present time there are 273.75 miles of single track under contract, but not in operation. It would be fruitless to draw elaborate deductions from these figures: they tell for themselves the story of prosperity and rapid growth throughout every department of the electric light and power industry.

“We are gathered not only for the purpose of seeing an exhibit of the latest forms of electrical apparatus and supplies, but primarily for the purpose of listening to papers and discussions upon all important electrical questions. Some of the subjects deserve special mention. Petroleum for fuel first received attention from this body at its last meeting. At this meeting several papers will be presented upon the subject. The question of the materials of underground conduits in relation to the insulating materials of cables will also be treated. The question of static charge on un-

derground cables, and the attendant puncturing thereof, will also be the theme of a paper. Electric-light stations as fire risks will be treated by an expert in fire underwriting, who has given especial time and attention to that branch of the subject. Municipal lighting will be the subject of one or two papers, and no doubt of a profitable discussion. The committee on underground conduits and conductors has carried on a correspondence with the electric-lighting fraternity, and it seems proper that the information gathered should be presented in Chicago, where the undergrounding of electric-lighting wires has been more practically carried out than perhaps in any other city in the world. This question, which is at present one in which diverse opinions are held by men of equal professional standing, is one which this association cannot afford at the present time to ignore or overlook."

After some routine business, came the report of the committee on patent legislation, which shows that much progress has been made in the direction of securing the establishment of a court of patent appeals. This court is to consist of three justices, appointed by the President, with the advice and consent of the Senate, to have appellate jurisdiction in cases touching patents, copyrights, trademarks, and labels. - "The expediency and propriety of, if not the necessity for, the establishment of such a court as contemplated by this measure," to use the language of the committee's report, "will not be questioned if proper consideration be given to the objects that will be attained by the passage of this bill."

It is claimed that such a court would enable the public and patentees to determine the value and validity of patents without serious and vexatious delays; that it would relieve the Supreme Court of much of the burden imposed upon it by this class of litigation; that practice in the patent office would become thoroughly fixed and understood, and the issue of worthless patents would be greatly diminished, if not entirely suppressed; and that it would tend to simplify the patent laws by construction, and settle questions of doubt which are often used by litigants for the purpose of injustice and oppression. Under the present condition of the business of the courts, it requires ordinarily from two to three years to obtain a decision in the circuit courts of the United States, and, if appealed to the Supreme Court, from three to four years are required to obtain a decision. The same difficulty and delay attend the determination of all other questions involving the determination of property rights. While this is true, it should be borne in mind that this species or character of property differs from all other kinds of property. The duration of the owner's title is arbitrarily fixed by law. The period is short, for the most part seventeen years. The Constitution imposes upon Congress the duty of securing to authors and inventors, for a limited time, the exclusive right to their respective writings and inventions. This duty is very imperfectly discharged, when, by the omission of Congress to provide proper means to determine questions arising out of patents, the life of a patent may be frittered away by the delays of the law.

The committee on insulation of wires and installation of plants being called upon for a report, it was shown that the duties of that committee were of such a character that no one engaged in the electric-lighting business would care to attempt to fulfil them: consequently there was no report to make, and the committee was accordingly discharged; as was also the committee on electrical education, which reported that Columbia College of New York had so effectively taken up the work of the committee as to render its further services unnecessary.

At the opening of the session of Wednesday, after the usual preliminary business was disposed of, the report of the underground committee was read. It contained a large number of answers to a circular issued by the committee relative to the operation of underground wires. The report was discussed by Professor Barrett, who said the underground problem was solved successfully in Chicago. Mr. W. H. Johnstone discussed the paper at length, and gave the results of experience with his own conduit, which has been laid in Philadelphia and New York. Mr. T. Carpenter Smith said that overhead wires, when well constructed, were the safest method of distribution. Mr. De Camp spoke of the non-success of running arc-light wires under ground in Philadelphia, and was joined therein by Mr. Charles Cooper and others. Mr. B. E. Sunny said that technically his underground arc wires

were successful, but their cost was very high, the expense of maintenance amounting to one cent per lamp per hour during an experience of ninety days.

The discussion induced by this report was exceedingly interesting, and made prominent the fact that many difficult problems relating to the transmission under ground of high-tension electric currents yet remain to be solved.

On Thursday, the last day of the convention, a resolution was adopted to the effect that the report of the committee on underground wires be recommitted, and three new members were added to the committee. This committee, the result of whose labors during the next half-year will be awaited with great interest, now consists of Messrs. Lynch, Barney, Kerr, Davis, Crocker, Sperry, Barrett, and Sunny.

A resolution was unanimously adopted by the association to the effect that the members of that body would decline to allow any electric current under their control to be used for the purpose of inflicting the death-penalty upon condemned criminals.

In the afternoon session the committee on insurance exchange made a report, describing the work accomplished by the New England Electric Exchange in the licensing of persons installing and operating electric-light plants, and recommending the organization of similar exchanges in every State.

Niagara Falls was selected as the next meeting-place of the association, the date to be determined by the executive committee; and the following officers were elected for the ensuing year: president, E. R. Weeks of Kansas City; first vice-president, A. J. De Camp of Philadelphia; second vice-president, E. A. Maher of Albany, N.Y.; executive committee, B. Rhodes of Niagara Falls, B. E. Sunny of Chicago, C. R. Huntley of Buffalo, Dr. O. A. Moses of New York, E. T. Lynch, jun., of Brooklyn, P. H. Alexander of New York, J. F. Morrison of Baltimore, and T. Carpenter Smith of Philadelphia.

Among the papers read at the convention were one by Mr. S. E. Barton, on "Electric Light Stations as Fire Risks," which was discussed by Messrs. Morrison, Alexander, and others; one by Mr. C. H. Rudd, entitled "Disruptive Discharges in Lead Cables," discussed by Messrs. Barrett, Lockwood, and Acheson; one by Mr. S. S. Leonard, on "Petroleum Fuel;" one by M. J. Francisco, on "Liquid Fuel;" and one treating of the "Advantages of Oil for Fuel," by Col. C. M. Ransom. The discussion of these latter papers was participated in by Messrs. Leonard, Lockwood, Ransom, and Francisco. Papers were also read by Mr. F. H. Whipple, on "Municipal Lighting," and by Mr. A. R. Foote, on "Public Ownership of Commercial Monopolies."

The interesting report of the committee on underground conduits and conductors excited a somewhat lively discussion, which was ably carried on by many of the members present. The further report of this committee at the next convention will be awaited with much interest, as the subject of putting electric-light wires under ground in our large cities has assumed great importance.

A party of sixty gentlemen, mostly electricians, visited the convention by special train from this city. The train consisted of three Pullman vestibule cars, a dining-car, and a combination car with bath-room and barber-shop. It was lighted throughout by electricity furnished by an Eickemeyer dynamo driven by a Brotherhood engine.

On the afternoon of Wednesday, after adjournment, a party of delegates and visitors to the convention paid a visit, by invitation, to inspect an installation of accumulators recently placed in the residence of Potter Palmer by the Electric Accumulator Company. The current is generated by one of the United States Company's dynamos driven by an Otto gas-engine. The plant works admirably, giving great satisfaction to Mr. Palmer as well as to the company which supplied it.

HARWOOD'S NITROUS-OXIDE BLOW-PIPE.

A SIMPLE and convenient form of compound blow-pipe, invented by Dr. G. F. Harwood of Worcester, Mass., is shown in the accompanying engraving. It is intended for use in scientific laboratories, technical schools, dental offices, and other places where a powerful and concentrated flame under perfect control is required.

The apparatus is so designed and constructed that it will take the necessary supply of nitrous oxide from the ordinary gasometer at low pressure, or from a gas cylinder at high pressure, and economically combine it with ordinary illuminating-gas in any desired proportion for producing and maintaining a flame of the requisite intensity.

In construction, the apparatus is simple and easily understood. It consists of an expansion-chamber or reservoir, *D*, provided with a lever stop-cock *A*, which is to be connected with the nitrous-oxide supply at the gasometer or cylinder by strong rubber tubing,

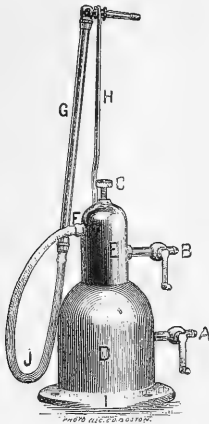

HARWOOD'S NITROUS-OXIDE BLOW-PIPE.

Above this reservoir is the mixing-chamber, *E*, with a lever stop-cock, *B*, to be connected by rubber tubing with the illuminating-gas supply. The expansion-chamber or reservoir is separated from the mixing-chamber by a diaphragm, which is provided with a regulating-valve, the stem of which projects upward through the mixing-chamber. By means of the small hand-wheel, *C*, on this stem, the admixture of the two gases may be perfectly controlled. The combined gases are conducted through the outlet *F*, and flexible tubing *J*, to the blow-pipe tube *G*. This tube is provided with interchangeable nozzles, by means of which either a large or a small flame may be secured. When not in use, the nozzle is supported by the curved wire standard *H*. The flange *I* is drilled for screws, by which the apparatus may be secured in any convenient position to the wall or to a shelf or bench.

BELLITE.

ON Tuesday, Feb. 5, a series of experiments were made at Chadwell Heath, England, with the new explosive, bellite, invented by Mr. Carl Lamb. A description of these experiments is given in *Engineering* of Feb. 8, 1889. Reference is also made to this explosive in the same journal for July 1, 1887, and in that for Nov. 9, 1888. The new series of experiments were fully as successful as those described in these articles, and the absolute safety of the new explosive has now been placed beyond cavil. The experiments were arranged in groups, each of which was intended to illustrate either a distinguishing characteristic of bellite or its adaptability to some specified end. The first experiment was intended to exemplify its use in submarine mining: 1½ pounds of the material was enclosed in a tin canister, and, on being fired by a detonator, the explosion sent the spray fully 150 feet high. The next group of experiments were made with the object of showing the perfect safety of the material, and that it could only be fired by a detonator. A bellite cartridge was broken in two, and one half thrown on a fire, where it slowly burnt away with a reddish flame: the other half, weighing about 2 ounces, was then exploded on a wrought-iron plate 12 inches by 12 inches by ¾ of an inch thick, the charge being tamped with clay. The shock bulged the plate to a

depth of about 2 inches, but did not pierce it. An even more convincing proof of its safety was afforded by the chairman of the company, who, holding part of a naked bellite cartridge in one hand, calmly applied a lighted fusee to the fragment with the other. The bellite charred and smouldered, but went out immediately on removing the match. The next experiment was a repetition, on a somewhat smaller scale, of one of the Middlesbrough experiments, described in the second of the articles quoted above. An iron weight, weighing 120 pounds, was dropped from a height of 18 feet on to a number of naked bellite cartridges supported on an iron plate. The test was repeated twice, as on the first occasion the weight fell somewhat to one side; but on the second trial, with more careful centring, the mass of bellite was crushed to a powder. This test was much less severe than the Middlesbrough one, when the weight was half a ton, and fell from a height of 20 feet; but a heavy weight of this character is not easily moved from place to place, and hence the reason for the lighter one. A small canister capable of holding 5 ounces was then filled with the fragments resulting from the last experiment, and laid on the web of an old Great Eastern Railway Company's steel-faced rail, the charge being slightly tamped with clay. On firing, the rail was snapped in two, a piece about 1 foot long being flung 6 yards, and smaller fragments much farther, while a pit 15 inches deep was sunk in the ground immediately underneath the position of the charge.

The next experiment was a repetition of one first made at one of the collieries of South Wales. In it 1 pound of ordinary blasting-powder and 1 pound of naked bellite cartridges were placed together in an open pit 1 foot 10 inches deep, and the powder ignited. Some pieces of the bellite were thrown out of the hole, and all were slightly charred, but none of it exploded.

To further illustrate the safety of the material, a fragment of bellite was fired from a large-caliber gun (No. 8) with two drams of powder, against an iron plate, without any explosion of the bellite occurring either in the bore of the gun or on striking the target. This experiment would, moreover, seem to prove that bellite is well adapted for use in shells, and the English Government is accordingly to be congratulated on not having spent large sums in acquiring the secret of melinite. It had been the intention of the experimenters to fire a bullet from the same gun at a target formed of bellite cartridges backed by an iron plate; but, owing to the jamming of a cartridge in the gun, this experiment had to be abandoned.

To compare the effects of bellite with those of dynamite, 2 ounces of each explosive were fired on wrought-iron plates measuring 12 inches by 12 inches by ¾ of an inch thick; each plate, with the object of rendering the conditions as uniform as possible, being supported above the ground by a narrow cast-iron ring about ⅝ of an inch thick, 3 inches high, and 11 inches internal diameter, the charge in each case being tamped with clay. Both plates were pierced through, but the rents in the one on which the dynamite had been fired were considerably larger, while, on the other hand, the bulge in this plate was only 2½ inches deep, as compared with 3 inches in the case of the other, thus showing the action of the dynamite to be more local.

The next series of experiments were made with a view to showing the adaptability of bellite to military purposes. To this end the ballistic properties of bellite and Curtis and Harvey's rifle-powder were first compared; a 6-inch ball, weighing 32 pounds, being fired from a mortar, first with ½ ounce of powder, and, second, with ¼ ounce of bellite, the weightings being carefully made in the presence of two representatives of the press. With the powder, the ball was thrown a distance of 40 yards 1 foot; and with the bellite, to a distance of upwards of 100 yards, the penetration into the ground being also much greater in this case.

Two mines had been prepared, one with 6 pounds of powder laid at a depth of 5 feet, and the other with 6 pounds of bellite laid at the same depth. In trying to explode these, however, it was found that in the passage of some of the spectators over the mine both fuzes had been pulled out from the bellite charge, and the attempt to fire it accordingly failed. A good idea of what the effects would have been, was, however, gained in the next experiment, in which a mine containing 8 pounds of bellite was fired underneath a length of railway laid down for the purpose. The explosion smashed both

rails clean through, and several of the sleepers were splintered, a large piece of one being flung fully 40 yards, while the crater formed was upwards of 12 feet in diameter. This, the most striking of the experiments, was also the last.

SCIENTIFIC NEWS IN WASHINGTON.

Bibliography of the Iroquoian Languages. — The Los Angeles Base-Line. — Deep-Sea Models.

Bibliography of the Iroquoian Languages.

SOME ten years ago Mr. Pilling of the Bureau of Ethnology entered upon the formidable task of preparing a systematic and exhaustive exhibit of all printed and manuscript works giving information respecting the speech of the native races of North America. The need of such exhibit had become strikingly apparent. For nearly four hundred years information had been accumulating respecting the North American aborigines, and this accumulated information had been printed in many lands in many tongues. The subject was fast becoming, or had already become, buried in the *débris* of its own literature. Special students found themselves consuming an inordinate amount of time in acquiring even an imperfect knowledge of the literature of the special subject of their study.

Recognizing this condition, the labor of preparing a bibliography of North American linguistics was, as already indicated, systematically entered upon more than ten years ago, and has been continued with only such interruptions as were necessitated by other official duties. The work before us¹ closes the third chapter in this work.

The first chapter or division of the work was a bibliography of the Eskimo languages, issued in 1887; the second, a bibliography of the Siouan languages, issued in 1888; and the third, that of the Iroquoian, now before us; to be shortly followed by the Muskogean, and later by the Algonquian and the Athabascan.

The aim to make the catalogue as exhaustive and complete as possible, and the dictionary plan of arrangement, carried to its extreme limit, remain the same as in the earlier bibliographies; and it may be added, that zeal in the pursuit of all information relating to the books catalogued, and fidelity in exhibiting this information, increase rather than diminish as time passes.

As a sample of Mr. Pilling's painstaking bibliographic research, the "Voyages of Baron Lathontan" may be cited. Seven pages of the bibliography are given to the careful and minute description of the eighteen editions of the work, which appeared in French, English, German, and Dutch. To collate these different editions, copies were borrowed from numerous sources, and photographs of titlepages made, that proof might be read from facsimiles. The careful scrutiny exercised in preparing these minute descriptions has developed the fact, that, from the original edition of 1703, two spurious editions of the same date were prepared. So far as ascertained, but one copy of the authentic edition is extant.

The catalogue contains, in round numbers 950 titles, of which 800 relate to printed and 150 to manuscript matter. Of these, Mr. Pilling has himself seen and described 850, or 89 per cent; and of the remaining 11 per cent, about two-thirds have been seen and described for this catalogue by his correspondents. Thus about 95 or 96 per cent of the entries are at first-hand; and, further, 61 per cent of the entries were compared directly with the original sources while the proof was passing through his hands.

Of the various languages included under the general term "Iroquoian," — viz., Cayuga, Cherokee, Hochelaga, Huron, Iroquois, Maqua, Minqua, Mohawk, Oneida, Onondaga, Seneca, Tuscarora, and Wyandot, — more than half of the material catalogued relates to the Cherokee and Mohawk only; most of the Bible, for instance, having been printed in each of these languages. Printed dictionaries of the Huron, Mohawk, and Onondaga, and manuscript dictionaries of the Seneca and Tuscarora, are in existence. There are in print rather extensive grammatical treatises on the Cherokee, Huron, and Mohawk, and fragmentary grammatical notes on several of the remaining languages. Of the Cherokee texts, all except two spelling-books, published in 1819 and 1824 respectively,

are in the Cherokee syllabary, these two having been printed before the invention of those characters.

The earliest printed record of any North American language appears to have been made by Cartier, whose first voyage was made in 1534, and the second in 1535. There is reason for believing that the original account of the first voyage contained a vocabulary of the people of New France; but, so far as known, no copy of this book is in existence, and the date of its publication is not known. The account of the second voyage was published at Paris in 1545, and contains a Huron vocabulary.

This is one of the rarest books in the entire list, only two copies having been known for the last three hundred years. Of these, one was bought in 1851, and lost in a ship on its way to America. The other and only known copy is in the British Museum. Of this "unique," Mr. Pilling gives a facsimile of the titlepage. Facsimiles are also given of several other rare, curious, or specially interesting books.

The work contains eight pages of addenda, which accumulated while the copy was in the printer's hands.

A chronologic list of authors at the end of the volume, covering eighteen pages, begins with Cartier in 1545, and ends with a list of nearly forty works issued in 1888. From an inspection of this list, it appears that interest in matters relating to the Iroquois was never greater than at present; and, while the literature of the subject has been accumulating during the past three hundred and forty years, more than half of it has appeared within the last forty.

The Los Angeles Base-Line.

The "Yolo Base," as it is familiarly known to geodesists, being the base-line measured in Yolo County, Cal., in 1881, for the transcontinental triangulation of the United States Coast and Geodetic Survey, was, in point of rapidity and accuracy of measurement, the best work of the kind ever performed. That measurement was made under the immediate supervision of Professor George Davidson, assistant United States Coast and Geodetic Survey, with the five-metre compensating base apparatus, which had been constructed at the office of the survey in Washington, under the supervision of Assistant C. A. Schott, and in accordance with a design prepared and submitted by him. The length of the "Yolo Base" was 17,486.5119 metres (10.86 miles). It was measured twice throughout its entire length, with a third measurement covering less than half (42.8 per cent) of its length. The two measurements and partial measurement occupied a total of forty-six days.

The recent measurement of a Coast and Geodetic Survey base-line near Los Angeles, Cal., which was concluded on the 16th of February, afforded to Professor Davidson, under whose supervision the work was also done, an opportunity of fulfilling his announced purpose of "breaking all records" of base measurements.

The "Los Angeles Base" is roughly 17,496 metres in length, or 9.5 metres longer than "Yolo Base." Although the weather was extremely unfavorable, the work having been pushed in the frequent severe rain-storms, which converted the line into a route of deep mud, standing pools, and rushing streams, three full measurements were completed in 46.75 days, the average measurement per day having been 1,122.73 metres, against an average of 912.5 in the "Yolo Base;" the longest measurement in a single day having been 2,000 metres, against 1,620 metres on the "Yolo Base;" and the cost, exclusive of the expenses connected with the establishment of monuments at the ends of the lines, was \$8,000, against \$15,578 for the measurement of Yolo.

It is hardly to be expected that the accuracy of the Yolo measurement, which involved a probable error of ± 0.035 of an inch per statute mile, or .38 of an inch in a length of 10.8657 miles, will be surpassed by that of the Los Angeles Base. If it is even equalled, the Los Angeles Base measurement will signalize again the unequalled proficiency of American officers.

Deep-Sea Models.

Mr. E. E. Court of the Hydrographic Office of the Navy Department has published two excellent models, — one of the Atlantic Ocean, the other of the Caribbean Sea. These accurate and neatly finished models convey an excellent idea of the configuration of the bottom of the sea which is only inadequately expressed to the in-

¹ Bibliography of the Iroquoian Languages, by James Constantine Pilling.

experienced eye by means of contour-lines. Therefore these models have a highly educational value, and will be used to the greatest advantage in the teaching of geography. One of the features most strikingly shown in the model of the Atlantic Ocean is the extent of the continental shelves both of the Old and of the New World. The abruptness with which oceanic islands rise from the greatest depths is also well shown. The deep valleys of the Gulf of St. Lawrence, of the Florida Strait, south of Cuba, and at the mouth of the Kongo, appear very distinctly and clearly, and the bold relief of the Mediterranean Sea is seen to be in striking contrast to the oceanic depths. The undulations of the ocean are shown not less clearly. The great transatlantic cables are shown. Mr. Court deserves the thanks of teachers of geography for having undertaken a work of this magnitude. As the prices are very reasonable,—being ninety dollars for the model of the Atlantic Ocean, and seventy dollars for that of the Caribbean Sea,—it is to be hoped that universities and colleges will possess themselves of these valuable works. The author has also published photographs of these models, which show the relief to good advantage, although of course not as clearly as the models themselves.

HEALTH MATTERS.

London, Ancient and Modern, from a Sanitary Point of View.

In *Nature* of Feb. 7 is an abstract of a lecture delivered by Dr. G. V. Poore at the Sanitary Institute on Thursday, Jan. 24. Dr. Poore began by reminding his hearers that the mere age of London was one of the reasons why it became unwholesome. Roman London was buried deeply among rubbish of all kinds, much of which was putrescible, and therefore a source of danger in the soil.

Ancient London was well placed, and magnificently supplied with water, for, in addition to the Thames, there were many streams, such as Westbourne, Tybourne, the Fleet River, Walbrook, and Langbourne, which originally were sources of pure water. All these brooks, however, had become disgracefully fouled, and for very shame had been covered over. One great drawback to the site of London was the proximity of marshy land on every side except the north-west, and formerly from this cause malarial fever and dysentery were great causes of the high death-rate.

In mediæval London, and even down to the eighteenth century, the houses were not so closely packed as they are now. Reference to Aggas's map (time of Elizabeth) would show that there was a great deal of garden-ground within the city; and, on comparing this map with Newcourt's map (Charles II.), it was evident that just before the Plague and the Fire the crowding of houses had become very much greater than it was in the time of the Tudor monarchs, who discouraged building near or in London.

Parker's map (1720) would also show that after the Fire the houses were not so closely packed as in the days of the Stuarts, for in this map a surprising amount of garden-ground is visible within the walls. At this time, also, Moorfields was not built upon, and remained as a playground and air space, as it had done for centuries previously. That mediæval London was very unhealthy, a perfect fever-den, there could be no doubt. The Black Death in 1349, and the Sweating Sickness two centuries later, were times of great mortality which struck the popular mind; but it was not till 1593, when bills of mortality were first introduced, that we began to have any certain knowledge of the amount or the kind of disease prevalent. There was reason to think, however, that in the eighteenth century (after the Fire and the Great Plague) the deaths exceeded the births by about 600,000 in the hundred years.

The fatal diseases were mainly malarial fever, small-pox, typhus, measles, and (latterly) whooping-cough. The causes of the enormous mortality of mediæval London were due (1) to the marshy undrained soil, fouled with refuse of every kind; (2) the filthy state of the unpaved city, and a perfectly swinish condition of the houses of the lower orders; (3) the ill-nourished and drunken condition of the masses, among whom a taint of scurvy was very common; (4) the condition of superstition and brutality (as evidenced by the punishments and the pastimes), which made any measures of public health impracticable; (5) the bad management of epidemics, with a total neglect to separate the sick from the sound; and, finally, the

medical faculty were scarcely less ignorant and superstitious than their patients.

Turning to modern London, the lecturer said there had been a great and manifest improvement; but, when we looked at the low figure which is called the London death-rate, several things must be taken into consideration: e.g. (1) the London of the registrar-general included large districts, such as Lewisham, Wandsworth, Fulham, etc., which, in great part, were scarcely urban in character, and these, being occupied largely by well-to-do persons, lowered the average death-rate for the whole city; (2) London being a city in which wealthy people abounded, its death-rate must not, in fairness, be compared to a city packed with undiluted operatives; (3) the mobility of the population was so great, that this fact must vitiate the statistics, and it was to be remembered that nothing quickened the departure of an individual from London more than ill health; (4) the age distribution in London was very abnormal, it was largely recruited by selected adults from the country, and there was a great deficit in the extreme ages, among which (the very young and very old) death-rate is always highest; (5) again, the diminishing birth-rate (that for 1887 was 2.8 below the average of the previous ten years) very greatly diminished the death-rate in a city where 158 children out of every 1000 born die before they are one year old.

It was difficult to believe that Londoners were very robust, when more than 25 per cent of them had recourse to the public hospitals in the course of the year.

The cause of the diminished death-rate (which was very considerably reduced after every allowance had been made) was due (1) to the increase of knowledge, not only among doctors, but among the people generally, for it must be remembered that "self-preservation is the first law of nature;" (2) vaccination, and the modern plan of treating infectious diseases by the prompt separation of the patients, had done a great deal (the total absence of small-pox and typhus were mainly due to these causes); (3) the cheapness of food, clothing, and fuel, had, of course, diminished the tendency to disease, and the ease with which fresh fruit and vegetables were to be got had abolished the taint of scurvy which was so fatal to previous generations; (4) the water-supply had been improved, and the intake of the water companies was now removed to a portion of the river less tainted with sewage than that formerly in use; (5) although the system of sewage-disposal was an undoubted evil, and had caused three or four epidemics of cholera, and was the foster-mother of typhoid, still it was probable that so far the balance for good was in its favor, because it had removed a good deal of filth from dwellings.

The outlook in the future was dashed by three considerations: (1) The system of sewerage and water-supply had increased overcrowding by enabling houses of any height to be built without inconvenience to the occupant, and without any curtilage whatever; and, since all sanitarians recognized that overcrowding was the greatest of all sanitary evils, it was impossible to shut one's eyes to this danger. (2) There was an expensive and menacing "loose end" to sanitation in the shape of 150,000,000 gallons of sewage pouring into the Thames every day. The only proper destination of organic refuse was the soil, and it was not possible to see the end of the gigantic blunder that had been committed in throwing it into the water. (3) The rapid increase of population along the valley of the Thames, where sewage-disposal is on the same lines as in London, must make the English apprehensive for their water-supply, because the various tricks played with sewage in the shape of precipitations, etc., were not probably of a kind to make the effluent a desirable or a wholesome beverage. If the evil effects of free trade are to be counteracted, it will be by returning the refuse of towns free of cost to the impoverished agriculturist. "If we go on as we are going," said the lecturer, in conclusion, "and if our brethren in the colonies follow our bad example, as they appear to be doing, it will be a Chinaman rather than a visitor from New Zealand who will sit in contemplation on the ruins of London Bridge."

LARGE deposits of lead and silver ores and coal have recently been discovered in the district of Kouban, Russia, on the Black Sea.

ETHNOLOGY.

The Races of Egypt.

In the spring of 1888, Professor R. Virchow visited Egypt in order to inquire into the physical character of the Egyptians, his special object being to study the influence of the climatic and other conditions of the country upon man, and the other question, to compare the type represented on ancient monuments with that of the present inhabitants. Far-reaching conclusions have been made from studies of ancient paintings and carvings, but so far no sufficient anthropological basis existed for these studies. From this point of view, Virchow's work is of special interest to the ethnologist. The "Proceedings of the Royal Geographical Society" contain a full report of Professor Virchow's observations, from which we glean the following notes. The author says, that, although a final and satisfactory solution of the question is not yet to be expected, the solution of it in the case of Egypt is of great importance, because in that country the oldest historical data have made us familiar with men of the most highly developed civilization, who, through the position of their habitation,—an island in the sea of desert,—appear, in the most remote times, to have been shielded from foreign influences. At the time of the most ancient historical king of upper Egypt, King Menes, who reigned about the year 6000, we find a people with all the arts of civilization, an elaborate state system, a complete hierarchy, famous monuments of architecture and sculpture, and the rudiments of painting. But what was the state of things before the time of Menes? Here the threads of history break off short: the prehistoric period is filled up by later Egyptian and Grecian writers by means of a promiscuous collection of legends and myths, of which the student can take no account; although Professor Lant of Munich has endeavored, and not without success, to extract a reliable historical kernel out of the myths. Since 1869, positive data have been continually collected, and the result is to show that there has been an Egyptian stone age. But between the latter and the age of Menes, which presents the arts of civilization in complete form, there exists a yawning gap; and we seek in vain for a connecting link between any one of the oldest temples near the Sphinx, which itself presents no inscriptions and decorations of the later age, and the period of the stone age. As to the conventionalism of Egyptian works of art, we know now some details.

The supposition which was long held, that the ancient Egyptians at the time of Menes correspond with the type of man to-day existing there has been shown to be erroneous. Since the mummies of the old Egyptian kings, such as Sesostris, Settri, Rameses, and others, were discovered in 1870, and the crania of these conquerors have furnished us with measurable data, it can be asserted with safety that the existing images and statues of these rulers are not portraits, but that the latter were fashioned according to a certain conventional design. We are not, however, in the same position with regard to the sculptures of the older dynasties. Of these we only find scanty remains. Some crania, authenticated, but partially covered by inscriptions, are the only relics which we possess of that earlier time; viz., from the fifth dynasty backwards. With these, however, the statues agree. They are the skulls of short heads, while the fellahen of to-day have long heads. This, then, at least, may be taken as settled,—that a change of type in the case of the dynasties has taken place. The case is otherwise with regard to the ethnological figures on the Egyptian works of art which are represented beside the king. These show that in the oldest historical times the different types of people, which we find up to this day in Egypt and the neighboring countries, were just as sharply distinguished from each other as they are now. The question in this case, however, is not about portraits, but about types, in which the essentials (such as the kind of hair, form of head, etc.) remain the same, while the externals (the armor, clothing, etc.) change according to the periods. The oldest representation of a negro is found in the tomb of Una, one of the kings of the sixth dynasty. In the opinion of many, especially of Lepsius, the territory situated between the first and second cataracts, between Assuan and Wadi Halfa, which is the true Nubia or Ethiopia, is the district where the change of the Central Africans into the Egyptians took place. It is the same region which for four

thousand years, down to the present time, has been the object of strife between the northern and southern races. In the oldest times the country which lies immediately south of Assuan was called Kash (the biblical Kush). Lepsius tried to prove, from considerations of language, that the inhabitants of Kash were negroes. The investigations of Professor Virchow on the spot, however, have resulted in establishing the contrary. The Nubians have, in skin, hair, or shape of head, no racial connection with the Nigritians, who are pure negroes. The Nubians, or, as they call themselves, the Barabra (Berbers) have to look for their kinsmen in the north, and not in the south. The Bedouins of the eastern deserts, the Bisharin and the Ababde, resemble them very much. As regards constancy of types, it is sufficient that no noteworthy changes have taken place within historical times. One of the most important anthropological characteristics is the color of the skin. In the case of the Nigritians, this is practically independent of all external circumstances; air and light have no effect upon it; the negro remains black. Among the northern inhabitants there is an important variability of coloring. Light and air exert a considerable influence upon the color of the skin of the Egyptian and Bedouin. The people of southern Europe also become dark in Nubia, but grow pale again when they return to the north. This fact furnishes the explanation of the diversity of coloring found in the old Egyptian pictures, which were painted according to certain rules, and in which the men appear always dark red, and the women light yellow. The prime color of the one is vermilion, and of the other orange. The former characterizes the man working out in the open air; and the latter, the woman working in the house, and thus preserving her light skin color. Greeks of the third generation living in Nubia have to-day a completely Kushitic appearance. This changeability of the color of the skin characterizes all the peoples as far as Dongola, where the Nigritians first begin, and forms the principal basis for the theory that the north and south of Egypt never belonged to each other ethnologically, and that the northern races of Egypt did not spring from negroes. The direct anatomical proof for this assertion cannot, it is true, be adduced, inasmuch as prehistoric skulls have not been found. Craniological studies point to the near relation of the Egyptians of to-day to the Berbers of Morocco and the Guanches of the Canary Islands.

DICULAFOY'S EXCAVATIONS AT SUSI.—One of the most important archaeological expeditions undertaken in western Asia is that of M. and Mme. Dicufofy, who were sent by the French Department of Public Instruction and of Public Works to Media and Persia to explore the remains of the ancient cities of these regions. Their first expedition was undertaken in 1881 and 1882, and their work was completed in the years 1884, 1885, 1886. The excavations, which were carried out with great difficulty, on account of the fanaticism of the inhabitants, have yielded valuable results from an archaeological as well as from an historical standpoint. The palaces of Artaxerxes and of Darius have been excavated, and it is now possible to reconstruct the plans of these magnificent buildings. The objects collected during these excavations have been transported to Paris, and form one of the most interesting departments of the new galleries of the Louvre. The collections contain polychromic bas-reliefs from the royal palace, representing lion and warriors, and potteries of the first or second century of our era. Besides architectural remains, numerous inscribed cylinders, ivory, bronze, and clay objects have been found. The palace, a model of which is being made, was a magnificent building rising on a platform sixty feet in height, protected by walls, and accessible only on the south side by a large staircase.

ETHNOLOGICAL COMPARISONS.—There are two methods of studying ethnology,—one by studying the growth of a single culture, the other by comparing isolated phenomena among a great number of tribes. While the former yields results of historical interest, the second is of prime importance to the student of psychology, who investigates the laws of the growth of human thought. R. Andree, who has for a long time continued the latter course of studies, has collected a series of essays on "ethnological parallels," most of which have previously been published in various journals. One of the most important results of such comparisons is the conclusive evi-

lence that many similar customs must have originated independently in regions far apart. Among many other phenomena, the author traces the occurrence of masks among various peoples, and shows that they occur all over the world, in America as well as in Australia and all parts of the Old World. It seems that the games in which our children delight are well-nigh universal. The children of the ancient Egyptians played tag; they had balls and dolls. Bodies of dolls were made of wood, and might be mistaken for modern fabrics. Undoubtedly they were dressed by the Egyptian girls, as our girls nowadays enjoy dressing their dolls. There were even movable ones, the hands and feet of which could be moved by means of strings. Others, made of painted wood, were very imperfect in form, and had strings of beads instead of hair. In the museum of Leyden there is an ancient toy that looks as though it had been bought at a Christmas fair. There were figures of animals with movable mouths, and balls of leather. Among Greek and Roman antiquities, dolls made of wood or clay, and others of wax and ivory, are found. Dolls' houses with lead furniture; the saving-box with a slit on top; toy cows, horses, and hogs, — were known to the children of ancient Rome, as they are to our own. From this evidence it might be supposed that our dolls are "descendants" of the ancient dolls; but it must be remembered that there is hardly any people that does not have them. Their use is so general, and so natural to the child, that even the laws of Mohammedanism are disregarded by the childish desire. The Koran forbids representations of human beings, and still the Mohammedan child plays with its doll. The women of Bagdad believe that a doll may eventually come to life, and harm their children, and therefore prevent their use. The girls, however, play with cushions and pieces of wood instead, which they nurse and dress. In Siberia and arctic America ivory dolls, clothed in furs, of beautiful workmanship, are found; in Peruvian graves, dressed dolls of clay are found; and in Africa the girls play with wooden or clay figures. In this way Andree traces numerous ethnological phenomena in their distribution among various peoples, and shows that the human mind everywhere develops on the same lines, and that a migration of inventions must be supposed only in such cases where its existence can be proved by historical facts.

ELECTRICAL NEWS.

Ether, Electricity, and Ponderable Matter.

SIR WILLIAM THOMSON'S presidential address before the English Institute of Electrical Engineers was looked forward to with some eagerness by electricians. The title given above is fascinating, and promises solutions of questions which have been asked for so many years, and whose answer had seemed so hopeless. We think that the address is disappointing. It tells us little that we did not know, and, although suggestive, it hardly points out how to follow the suggestions.

After a few introductory remarks, Sir William dwelt briefly on the necessity of an electrician being also an engineer. He would give a youth desiring to take up the study of electrical engineering a good deal of chemistry, of mathematics, and of dynamics. "I am perfectly sure, that, if the youth is qualified in other departments, the mere addition of electricity to the education of a competent engineer will not take such a long time as might be imagined, and that the merely educational part of the work will not be protracted unduly by adding electricity to the branches learnt in general engineering."

Passing to the main subject of his address, Sir William spoke of the demand that was every year growing in intensity, for something like a mechanical explanation of electrical phenomena: "to know something of the internal relations connected with the wonderful manifestations of force and energy which are put before us in the action of the magnet, in the working even of a common electrical machine, and in electro-magnetic phenomena." The question of the transmission of messages through cables was then taken up at some length, and the history of the theory on which the first Atlantic cable was constructed was given. Sir William then spoke of the two effects which must be considered when an electrical wave is transmitted, — that due to static induction, and that due to magnetic induction. In the first solution of the problem, only the

static effects were considered, since the propagation was so slow that they were large compared with the magnetic effects; but Mr. Heaviside has lately shown that the magnetic induction is really an advantage in signalling or in transmitting speech by telephones, since it makes the dying-out effects much more uniform. If only static induction were considered, the waves of short period would die out more quickly than those of greater length. The magnetic induction helps to make this difference less, and is therefore beneficial.

Taking up the subject of alternating electric currents in wires, the speaker gave some figures on the increase in the resistance of a wire carrying alternating currents as compared with the resistance of the same wire for continuous currents. It has become well known in the last few years that the distribution of a varying current in a wire is not uniform, but the density is greatest near the outside. This has the effect of increasing the resistance; for instance, taking a period of 80 reversals per second, the increase in resistance of a wire 1 centimetre in diameter is not so much as .01 per cent; for a diameter of 1.5 centimetres the increase is 2.5 per cent; for 2 centimetres it is 8 per cent; for 4 centimetres, 68 per cent. For periods of twice the frequency we must multiply by $\sqrt{2}$. The inward penetration of the current into the wire may be compared to the motion of water in a long tube, when the tube is moved backward and forward in the direction of the axis. To represent the case of alternating currents in parallel wires, Sir William would replace the wires by densities of fluid in direct proportion to the electric conductivities, the space around being a fluid without mass, the cylinders of dense matter rotating periodically in opposite directions. To represent the electro-static effect in such a case, "imagine an interface between the two fluids, and give it such stiffness against change of shape as is required to cause it to fulfil the conditions which electro-static knowledge, and our knowledge of the laws of electric and electro-magnetic influence, dictate to us."

Sir William then went on to say that he believed that an electric current actually caused a rotation of the ether, and considered the case of a copper core surrounded by a helix. Induced currents were set up in the copper, and the only action conceivable in the space between the coil and the core was a rotation. This might be either a continuous rotation, or a rotation through an angle proportional to the strength of the current. In iron, however, something quite different must take place. If the fluid whose rotation caused the observed effects moved around continuously, there would be no shearing. If, on the other hand, there were only a drag upon the ether through a certain angle, then there must be a force resisting steady rotation; that is to say, there would have to be an arrangement of such character that a constant torque would produce a constant instead of an accelerated rotation. It would appear that such an effect could only be produced by an inherent rotation of the molecules. To represent a medium of this kind, Sir William imagines a space divided up into a number of small squares, with their sides fixed together by rubber bands. In each a gyrost at in the form of a rotating molecule is placed. Such a medium, without the gyrostats, would represent a perfect fluid; but, with the gyrostats in place, turning could only take place by stretching the elastic bands, which would require a constant force. On this hypothesis, we must suppose that the ether is less rigid in iron than in other metals, and has the same rigidity for all non-magnetic substances. But no model that can be imagined can represent the electro-static as well as the magnetic effects. In concluding, Sir William pointed out that even the very imperfect attempts at a mechanical explanation of electrical phenomena which he had indicated would only apply to a very small part of the subject; and the tremendous difficulties in the way of a complete mechanical explanation prevented him from hoping to see the question solved in his own lifetime, though he felt confident that a solution would be found, and that what appeared so insuperable a mystery to us would be no mystery at all to future generations.

AN ELECTRIC DATE STAMP. — According to *Engineering*, the Electric Date and Time Stamp Company are introducing a new stamp, which at one operation marks on any document the minute, hour, day, month, and year, as well as the usual address and business of the proprietor. Unlike many automatic appliances which are dubbed electrical merely for the purpose of imposing on un-

wary customers, the electric current is really employed in this piece of apparatus. The device consists of five type-wheels with connecting gear, disposed on a single axis; and the minute, the hour, the day, the month, and the year are correctly placed in line under the impression-pad. The minute-wheel is actuated by any clock, through the instrumentality of an electric current, which shifts it round minute by minute, a pawl carrying round the hour-wheel when sixty movements have been made. The apparatus is under trial at the London General Post-Office for dating telegrams.

THE PRODUCTION OF ELECTRIC CURRENTS BY MECHANICAL ACTIONS. — The following interesting experiment is due to M. Siljestroem. Two hollow iron cylinders were closed at one end by the same plate of german silver, and were plunged in ice. They were connected with a galvanometer, and, when the air in one of them was compressed to 86 atmospheres, a current was observed which was in the opposite direction to that which would be produced by an elevation of temperature, although there was a momentary current in the same direction as the latter.

EDISON ILLUMINATING COMPANIES. — The development of the electric-light business is well shown in the holding in Kansas City, on Feb. 12-13, of the semi-annual convention of the Association of Edison Illuminating Companies, a full report of which appears in the *Electrical Review*. The Edison meetings of this kind have invariably been for "business." The policy of President John I. Beggs has always been to hold the convention closely to its work up to the final adjournment, leaving the question of recreation as a secondary consideration. The convention, while not as large as on former occasions in the number of delegates in attendance, was one of absorbing interest, the papers were more numerous and comprehensive than at previous meetings, and there was nothing lacking in the discussions of the vital features of the business with the exception of the unavoidable absence of Mr. Edison and President Johnson, of the Light Company. It was but natural that a sense of exultation at the prospect of speedy results in the fight for the supremacy (which, if the patent laws of the United States mean any thing, are now near at hand) should be evident in all the utterances of the discussions. The cloud of uncertainty which long litigation always brings seemed to be lifted, and a tone of assurance and expectancy was one of the marked features of the session. A paper was read by J. H. Vail, general superintendent of the Edison Electric Light Company, on electric railways and their relations to Edison central stations, illustrating by statistics the advantages to be derived from their operation by Edison illuminating companies. A detailed statement was made by J. H. McClement, comptroller of the parent company, on the progress of the patent litigation. This was supplemented in the evening by a stereopticon entertainment arranged by W. J. Jenks, director of the Standardizing Bureau, showing in a series of slides the history of Mr. Edison's work. An interesting discussion of the results of the use of the Edison chemical meter brought out a paper of great practical interest by E. A. Kennelly of the Edison laboratory, under whose direct supervision experiments have been conducted the past year. The meter has been cheapened both in first cost and expense of maintenance, and samples of new types are now being made for the Paris Exposition. The possible errors, never large under reasonable management, have practically disappeared. A paper on the "Commercial Mean of the Incandescent Lamp," by Mr. Edison, was read by Mr. Upton of the Edison Lamp Company. This set forth in amplified form the practical results of the operation of the laws regarding lamp efficiency brought out some time ago by John W. Howell. It also detailed some interesting facts as to lamp breakage in central stations. The discussions developed the fact that one result of Mr. Edison's experimental work has been to secure fifty per cent more light from the same energy expended, while fully maintaining the guaranteed life of lamps, as a matter of actual record. The other papers were on "Medical Applications of Current from Central Stations," by J. W. Parcell, jun., of the Sprague Electric Railway and Motor Company; "The Steam-Engine," by Professor William D. Marks of Philadelphia; "Inspections," by W. J. Jenks. The executive committee reported in favor of holding the next meeting at Niagara Falls.

NOTES AND NEWS.

It is announced that Great Britain, France, Germany, Spain, Italy, Denmark, the Netherlands, Norway and Sweden, Brazil, Uruguay, Chili, Japan, and the Sandwich Islands have signified their intention of sending representatives to the International Conference which is shortly to be held to consider some means of signalling at sea that will render collisions less liable to occur than under the present system. The proposed conference is the result of a letter addressed to the different maritime powers of the world by the President of the United States, asking their co-operation in this matter. The date and place for holding the meeting yet remain to be fixed.

— Russia's boldness in pushing on her railway system across the Turcoman region to Central Asia has received its due reward. Already the line is declared to be paying its working expenses; and Gen. Annenkoff, the designer, has been encouraged thereby to ask permission of the Emperor to extend the line still farther to Tashkent. In all probability, the request, according to *Engineering*, will be acceded to, because Tashkent, besides being the administrative centre of the province of Turkestan, is a town with a population of 100,000 people, and the extension of the Samarqand section thither would not only tie an important political and trading centre to the Russian railway system, but also link the Syr Daria River and the Aral communications with those of the Caspian. The Aral fleet, as originally established, used to ply on the Syr Daria River, along the banks of which the Russians marched, and founded a series of forts and colonies, in their advance upon Tashkent and Samarqand. The great drawback the steamers had always to contend with was the absence of any fuel except a kind of brierwood known as saxaul. If the Samarqand line were extended to Tashkent, it would cross the navigable head of the river on its way, and be able to provide the steamers with liquid fuel from the Caspian, similar to the supply the railway was able to accord to those on the Oxus when it penetrated to that river a year ago. North of Tashkent stretches a series of steppes, adjoining those of Siberia, which are being gradually settled by colonists from Russia. This region, which is well adapted for agricultural and pastoral pursuits, would benefit considerably by the extension of the railway to Tashkent; so that Gen. Annenkoff has many cogent reasons, besides those of a military character, to adduce in support of his project. It is curious to contrast this activity of the Russians with the lethargy of English authorities in regard to the Indian frontier communications. If the completion of the Quetta line to Candahar would not pay the whole working expenses of the railway from the Indus, it would at least more than pay that on the extension, while adding immeasurably to the security of the Indian Empire. In Burmah again, where Gen. Sir Frederick Roberts, four years ago, urged upon the government the rapid construction of railways as a means of pacifying the country, no important lines, except the slow-paced Tounghoo-Mandalay line, have been taken in hand, and money is being wasted in punitive expeditions against dacoits and tribesmen, which would have been far more advantageously spent on railway-works.

— For paving streets, India-rubber threatens to enter into competition with asphalt. This new pavement, according to the *Engineering and Building Record*, is the invention of Herr Busse of Linden, Prussia, who has introduced it in Hanover. He used it first in the summer of 1887 for paving the Goethe Bridge, which has a surface of about 1,000 square metres, or 10,764 square feet. The new pavement, it is stated, proved so satisfactory that 1,500 square metres (16,146 square feet) of ordinary carriage-way in the city were paved with it last summer. The Berlin corporation, being favorably impressed with the new pavement, has had a large area paved with India-rubber as an experiment, and the magistracy of Hamburg is likewise trying the pavement. It is asserted that the new pavement combines the elasticity of India-rubber with the resistance of granite. It is said to be perfectly noiseless, and unaffected either by heat or cold. It is not so slippery as asphalt, and is more durable than the latter. As a covering for bridges, it ought to prove excellent, as it reduces vibration; but a question may be asked as to its cost. The expense must be heavier than that of any known pavement.

SCIENCE:

A WEEKLY NEWSPAPER OF ALL THE ARTS AND SCIENCES.

PUBLISHED BY

N. D. C. HODGES,

47 LAFAYETTE PLACE, NEW YORK.

[Entered at New York Post-Office as second-class mail-matter.]

SUBSCRIPTIONS.—United States and Canada.....	\$3.50 a year.
Great Britain and Europe.....	4.50 a year.
Science Club—rates for the United States and Canada (in one remittance):	
1 subscription 1 year.....	\$ 3.50
2 " " 1 year.....	6.00
3 " " 1 year.....	8.00
4 " " 1 year.....	10.00

Communications will be welcomed from any quarter. Rejected manuscripts will be returned to the authors only when the requisite amount of postage accompanies the manuscript. Whatever is intended for insertion must be authenticated by the name and address of the writer; not necessarily for publication, but as a guaranty of good faith. We do not hold ourselves responsible for any view or opinions expressed in the communications of our correspondents.

VOL. XIII.

NEW YORK, MARCH 1, 1899.

No. 317.

CONTENTS:

THE ELECTRIC MOTOR IN FACTORIES.....	153	EDITORIAL.....	162
CONVENTION OF THE NATIONAL ELECTRIC LIGHT ASSOCIATION.....	154	Contagiousness of Consumption.—Sanitation in Buenos Ayres.....	
HARWOOD'S NITROUS-OXIDE BLOW-PIPE.....	155	TO-DAY'S NEED AT JOHNS HOPKINS UNIVERSITY.....	D. C. Gilman 162
BELLITE.....	156	GROWTH OF THE AMERICAN ECONOMIC ASSOCIATION.....	163
SCIENTIFIC NEWS IN WASHINGTON.		THE WEATHER SERVICE.....	164
Bibliography of the Iroquoian Languages.....	157	MENTAL SCIENCE.	
The Los Angeles Base-Line.....	157	The Genesis of Error.....	164
Deep-Sea Models.....	157	Abnormal Sense-Associations.....	165
HEALTH MATTERS.		BOOK-REVIEWS.	
London, Ancient and Modern, from a Sanitary Point of View.....	158	Physical Realism.....	165
ETHNOLOGY.		The Development of the Intellect.....	166
The Races of Egypt.....	159	Political History since 1815.....	166
Dicaulfo's Excavations at Susa.....	159	Shall We Teach Geography.....	166
Ethnological Comparisons.....	159	A Historical Geography of the British Colonies.....	166
ELECTRICAL NEWS.		AMONG THE PUBLISHERS.....	167
Ether, Electricity, and Ponderable Matter.....	160	LETTERS TO THE EDITOR.	
An Electric Date Stamp.....	160	The Soaring of Birds.....	
The Production of Electric Currents by Mechanical Actions.....	161	G. K. Gilbert, Arthur L. Kimball 169	
Edison Illuminating Companies.....	161	To keep Water-Mounts Moist.....	E. B. Kneerr 170
NOTES AND NEWS.....	161	Color-Blindness a Product of Civilization.....	L. J. Blake; W. S. Franklin 170
		Note on the Wind-Pressure Constant.....	Wm. Ferrel 171

IN A RECENT NUMBER of *Science* we called attention to the danger to which travellers on ocean steamers are subjected when their stateroom companions happen to be consumptives. That this danger is not an imaginary one seems to be demonstrated by an incident which recently occurred in France. A French physician, Dr. Gautier by name, has been investigating the question whether tuberculosis may be communicated by means of its bacilli. That this is possible for lower animals has been thoroughly proved. Dr. Gautier has himself fallen a victim to the disease, having become infected from the pulverized tuberculous sputum with which he was experimenting, thus showing that the disease is equally communicable to man.

WE ARE NOT APT to look to South America for evidence of the greatest progress in science or art, and yet it is said that the sewerage system which is now being constructed in Buenos Ayres is the most perfect in the world. Measures have been taken which will result in putting every house in the city in perfect sanitary condition within three years. Sanitarians will watch the result of this stupendous undertaking with great interest, and will be able to deduce from it many valuable practical lessons.

TO-DAY'S NEED AT JOHNS HOPKINS UNIVERSITY.¹

YOU have doubtless observed, that though this is our annual celebration, when memory and hope are the keystones of a festival, yet there is an undertone of anxiety, an unwonted seriousness in our demeanor and in our words. You know as well as I the cause; but you do not know as well as I the resolution which determines us to turn a temporary loss into a permanent gain. The best financiers can do no better. It is true that we have lost for a time our income from the Baltimore and Ohio Railroad, the securities to which the sagacious founder of the university intrusted his endowment, with so much confidence that he recommended his trustees not to dispose of the stock, but to keep it as an investment. He was doubtless influenced by the fact that this security was free from the taxation which would fasten itself upon another investment.

We believe that this suspension of dividends upon the part of the Baltimore and Ohio Railroad is but temporary, and that the stock is now, and always will be, property of great value. But we have possessions of even greater worth. The Johns Hopkins University owns nearly three hundred acres of land within the present limits of the city, which will soon be laid out in streets and avenues. Fifteen or sixteen miles of street frontage can then be sold or rented. "The past at least is secure;" but to this familiar utterance we can safely add, "the future is as secure as the past." Our cause for anxiety is the present. How shall we make the transit between the prosperity of the past ten years and the prosperity that is to follow? How shall we meet the emergency of the next five years?

There are but three ways, — contraction, borrowing, begging. Contraction brings disaster, borrowing brings a day of reckoning, begging is not pleasant.

It is not agreeable to the managers of a great institution to ask the public to come to their support. It is natural that they hesitate before taking any such step. It is particularly difficult for those who have devoted their lives to the advancement of knowledge and the education of youth, who have renounced aspirations for wealth, who seek for no other preferment than the modest distinctions of an academic life, who are willing that their families should grow up without expectations beyond the inheritance of an honorable name, and who only ask, that, with proper books and apparatus, they may be allowed to continue in the service to which they have consecrated their lives — I say it is especially hard for such persons to ask the public to come to their relief. So it seems to fall upon me, who am not a professor on the one hand, nor a trustee on the other, to say the few frank words which others hesitate to utter.

The situation is this. A prudent management of our affairs during the last few years has enabled the trustees to pay all their current expenses, to build three great laboratories, to collect a large library and a great amount of apparatus, and to buy a great deal of real estate for the buildings that are wanted, and at the same time to lay by a considerable amount of accumulated income. This store they are now spending. It is not, like the widow's cruse, inexhaustible; but if the sum of \$100,000 can be added to it, and if our receipts from tuition remain undiminished, the university will go forward during the next three years without contraction, without borrowing, and without begging. I am happy to say, that although the trustees have not felt willing to make an appeal to the public, and although no authorized statements on this subject have been published, a number of the citizens of Baltimore have, of their own accord, expressed the desire to raise this amount, and have pledged themselves for generous sums. It would be difficult for me to express the encouragement I have received, as one and another of these helpful friends have intimated their readiness to contribute liberally toward the desired amount. More than half of the proposed fund has already been definitely pledged. One subscription has come from New York, another from Liverpool; but almost all, as we might expect, have come from those who are most intimately acquainted with the working of the university, — our own neighbors and friends, who know the difficulties under

¹ Remarks of Daniel C. Gilman, president of the Johns Hopkins University, on the thirteenth commemoration day, Feb. 22, 1899.

which we labor, the methods which we follow, and the hopes by which we are inspired.

A most gratifying sign is the eagerness which young men, whose accumulations as yet are but small, have shown in their desire to come to our assistance. Many such persons are among our own former pupils; others are but lookers-on in Baltimore. I am sure that if it were worth while, the amount still lacking could readily be made up by the contributions of those whose love to their young alma mater is as loyal as that of the sons of Harvard, Yale, and Princeton. Here, for example, is the letter of a Baltimore boy, enclosing a modest check for forty dollars, which, although it is marked "private," I venture to read in part:—

"I can never cease to retain the warmest feelings for my alma mater, for I am not only doubly an alumnus of the university, but am also, by birth, a Baltimorean, and of an old Maryland family, and as such am proud that the greatest American university is to be found in my city and State. I beg, therefore, that you will accept the enclosed check. . . . If you think it desirable, I should be happy to have you call on me for a yearly payment of one hundred dollars as long as the university fails to receive an income adequate to meet its expenses. No one is more keenly sensible than I of the extreme paltriness of this sum. I regret that it is all that I can do; but I can say that if others, equally interested, would contribute in proportion to their income, as I have done with mine, the university would never have to fear pecuniary embarrassment."

But it will not be necessary to ask such aid. The mature and prosperous citizens, who know the conditions of municipal advancement, who know the value of a good name, who know that not money alone has lasting value, but that which money brings in education and refinement, the mature and prosperous citizens of Baltimore, who have received two great gifts from men of New England birth, and two great gifts from an Anne Arundel boy, cannot afford to let an institution that has made the fair name of this city familiar to the scholars of every race and every clime, relinquish in a day of temporary embarrassment the prestige which has been acquired by thirteen years of labor.

GROWTH OF THE AMERICAN ECONOMIC ASSOCIATION.

THE American Economic Association has issued a report, by E. W. Bemis, Ph.D., of its branch associations. Eighteen months ago, Mr. Bemis, as secretary of the first economic branch of this association, reported its success, and urged the organization of similar associations elsewhere. That suggestion has been adopted, and now there are six branches, with over one hundred and fifty members, in the following places: Springfield, Mass.; Orange, N. J.; Washington, D.C.; Buffalo, N.Y.; Galesburg, Ill.; Canton, O.

In view of the great possibilities of growth and influence of these economic centres throughout the country, it becomes important to decide upon a plan of organization. These branches are of three types,—that of Springfield, of Galesburg, and that of Buffalo as at present organized.

The Connecticut Valley Economic Association, organized at Springfield in January, 1886, and now numbering about fifty members, has prospered from the first. This association, like others, is allowed to retain one-half of the three dollars dues for local expenses; and this small sum, thanks to the generous help of the able speakers who have come to Springfield, has thus far covered all expenses. A good room, lighted and heated, is given without charge in the High School building. Similar cheap but suitable places for meeting have been secured in public buildings and private offices by the other branches. Meetings have been held once a month save in summer, and many original contributions to economic theory and investigation have been given which have since seen the light in our economic quarterlies and monographs. A large proportion of these has been given by professors of New England and New York colleges, and by others not connected with the local branch, though six or eight members have also made valuable addresses.

Successful as this experiment has been in many ways, three weak points have been developed: first, a difficulty in securing able lecturers whose regular work would admit of a visit to Spring-

field,—a difficulty less felt in this branch than would be true almost anywhere else, owing to the peculiarly favorable location of Springfield within thirty miles of Amherst and Smith Colleges, and one hundred and thirty miles of Harvard, Yale, Brown, and Columbia, yet a real source of anxiety often to the officers, and one likely to grow from the exhaustion of the field of economic teachers and writers of note within reasonable distance, for it is too much to ask the same person from outside the branch to give his strength often in this missionary work; the second weakness in the Springfield plan lies in the almost inevitable lack of continuity in economic study as long as a different subject is taken up at each meeting; the third difficulty has been the failure of a monthly address, followed by a general discussion, to draw out the resources and greatly stimulate systematic reading in the science of economics on the part of the main body of the members.

That these are sure to prove serious obstacles to success has been proved in Buffalo, where a branch similarly organized a year ago, but cut off by distance from well-known economists, languished, till restored to vigorous life last month in the manner soon to be described.

The branch at Galesburg, Ill., has avoided the difficulties thus far described, but has fallen into one or two others. There the number in the association is limited to twenty-five, elected by the existing members; and no one is allowed to join who does not assume the responsibility of preparing in turn, about once a year, a paper for one of the fortnightly meetings. Further, in order to secure continuity of study, half a dozen or more meetings in succession take up various phases of a single subject, as money, monopolies, the labor question, taxation, etc. By this form of organization much mental development and great interest have been secured; but the limitation of membership and the conditions of admission have kept away a number who would like to join.

The attempt to combine the Springfield and the Galesburg plans has just been made with prospect of success in Buffalo, N.Y., and Canton, O. At Buffalo a reading-circle within the local branch has been formed of all the local members ready to submit to the conditions of admission, which are, attendance, if possible, at every fortnightly meeting, and assumption of the work involved in preparation for the meetings, at which two lines of study are taken up. The first forty-five minutes of each meeting is to be devoted to systematic study of some portion of the general subject assigned for five to eight successive nights: thus, Professor Ely's "Taxation in American States and Cities" is now being studied. Each of the twenty members of the reading-circle reads in advance as much as possible of the chapters assigned for the meeting, and joins in discussion, after two or more members, appointed for the purpose a month previous, and selected in turn from all the members, have given a digest and criticism of the chapters under consideration. The second forty-five minutes is taken up with a review of recent economic articles in twenty-six different American and European magazines, consular reports, and other official publications. One or two of these magazines are chosen for review throughout the year by each member. No constitution for this inner circle has been adopted, but every one who joins does so with a clear understanding of the obligations thereby assumed. The chair is filled each evening by nomination, and the secretary of the general association is secretary of the inner circle. The selection of topics and speakers is in the hands of a topic committee.

This form of organization is too recent to give much ground for forecast; but if the character, ability, and enthusiasm of the members as witnessed by Mr. Bemis the past month be any criterion, excellent results are probable. The Springfield idea of securing for the general membership addresses from outside is adhered to, but no attempt will be made to secure more than four or five such a year.

At Canton, O., about twenty persons, both men and women, as in all the branches, have just formed a branch similar to that as now re-organized at Buffalo, save that in Canton the inner reading-circle, or the active members so called, elect all the officers of the branch from their own number, and admit the associate members to the meetings and discussions, as is not done in Buffalo save on direct invitation of some active member. In Canton the method of work and the conditions of active membership are like those in

Buffalo. In both places local researches in taxation and other economic subjects are also contemplated. The secretary of the Canton branch reports that Professor Ely's "Problems of To-Day" is being studied, and that "the members are enthusiastic."

The branches at Orange, N.J., and Washington, seem to have patterned largely after the Springfield plan.

These suggestions may furnish some help in the solution of the problem of how to extend the work and influence of the association, and form centres of economic study in many parts of our country.

THE WEATHER SERVICE.

THE popular dissatisfaction with the weather predictions as now furnished by the Signal Office has become so great, that a thorough discussion of what is best to be done to improve the service is certainly desirable. Such a discussion has been taking place in the columns of the *Boston Post*, and from that paper we here quote from a recent letter of Mr. H. H. Clayton of the Blue Hill Meteorological Observatory, Readville, Mass. In an editorial note the *Post* seems inclined to doubt the wisdom, if not the truth, of the sweeping assertion of the inefficiency of a large part of the Signal Corps made by Gen. Greely in his recent report to Congress, and it was this which called forth Mr. Clayton's letter in which he takes the following ground.

"Gen. Greely may possibly not be right in his specifications as to exactly what persons are inefficient, but any one who has studied the history of our weather service in comparison with that of foreign countries can scarcely doubt but there is great inefficiency somewhere in our service; and it seems right to allow Gen. Greely every assistance possible to improve the service, until there is proof that his efforts are in the wrong direction. The financial support and the facilities afforded our signal service are the best in the world, and it has been a continuous surprise to the writer that its efficiency has not been greater. The following figures show in round numbers the amount of money appropriated by various governments in Europe and America for the support of their weather services: United States, \$900,000; Great Britain, \$80,000; Germany, \$56,000; Russia, \$65,000; Austria, \$10,000; Switzerland, \$6,000; France, \$40,000. This estimate for France does not include the cost of observations made at a few astronomical observatories and mountain stations, which may perhaps increase the total amount expended by France to \$60,000. It is thus seen that the amount of money appropriated for its weather service by the United States is ten times greater than that of any country in the world, and is greater than the amount appropriated by all of the governments of Europe combined, including Italy and others not mentioned above.

"In Europe a large part of the observers are voluntary observers, or they are men who are engaged in other pursuits, and for a small compensation take meteorological observations, and telegraph them to the central stations. For this reason it has been necessary to adapt the observations somewhat to the convenience of the observers, and it has been impossible to obtain all over Europe a system of simultaneous observations such as are obtained in the United States. The principal set of observations in the different European countries is taken all the way from 7 A.M. to 9 A.M.; and on account of the difficulty of arranging codes, and transmitting telegrams from one country to another speaking different languages and having different interests, it is almost noon before the morning observations are in an available form in the different countries for use in making weather predictions, while in the United States it is but little more than an hour after the observations are taken before they are available for use at the central office. Again, owing to their small appropriations, none of the European countries have been able to obtain extensive reports more than once a day from surrounding countries, and thus form a set of relatively complete weather maps, such as was previously done three times a day in the United States, and is now done twice a day. The full weather map made by the European weather services is from the morning reports taken between 7 and 9 A.M., though most of the services make supplementary maps from less complete reports received in the afternoon and evening.

"So far, it is seen, then, that our weather service is better equipped, and with far better facilities for effective work, than any service in the world; but what are the results? In 1881 the per cent of verification of their weather predictions estimated by the French meteorological office was 82. Since then it has steadily risen, until, in 1888, a verification of 90 per cent was claimed. In the same manner the per cent of success estimated by the London office for Great Britain has risen from 78 per cent in 1882, to 83 per cent in 1887. In Germany the per cent has risen from about 80 per cent ten or twelve years ago, to 88 per cent in 1887. According to the official verifications of our signal service, the per cent of successful weather predictions rose from about 82 per cent in 1875, to 89 in 1883, and then decreased irregularly to 74 per cent in 1887, or 81 per cent when corrected for the greater interval covered by the predictions. These signal-service verifications for different years are not strictly comparable, because they were verified according to varying rules and with different degrees of care; but the signal service uses them so, and the figures at least agree with the general impression that there has been no increase in the accuracy of the signal-service predictions during the last fifteen years. Neither are the per cents of verification for one country comparable with another, since many of them were verified by different rules; but the results are comparable among themselves, and the steady increase of accuracy claimed for the European weather predictions is no doubt a fact. The able papers and investigations proceeding from the members of the European bureaus seem sufficient evidence that great thought is being given to the improvement of meteorology, and the advance of meteorological knowledge is undoubted.

"The great difficulty with our bureau seems to have been that Congress made it a military rather than a scientific organization. Several years ago a committee appointed to investigate the bureau recommended that it be transferred to a civilian organization, either gradually or suddenly. The National Academy of Science, when consulted on the subject, recommended the same thing; but for some reason unknown to the writer, Congress has neglected or refused to make such a transfer, and last year struck out a clause to that effect in the agricultural bill. There is scarcely any doubt, that, with some scientific investigation, certain of those storms might have been predicted which in recent years have struck our coast unheralded by the signal service, and left wreck and ruin behind,—notably the storm of Jan. 9, 1886, for which no signals were ordered, and in which it is estimated that about 125 vessels were wrecked on the New England coast. Were the weather service of our country in the hands of well-selected scientific men, it would undoubtedly become, as it ought to become with such splendid facilities as it now has, one of the finest meteorological bureaus in the world. If, however, this cannot be, it is hoped that every facility will be furnished Gen. Greely to make it an effective military organization. Gen. Greely's recent books and excellent 'Report of the Lady Franklin Bay Expedition to the Arctic Regions' indicate a deep interest in and a knowledge of the needs of meteorology, and he is no doubt sincere in his efforts to increase the efficiency of the Signal Corps.

"Besides the re-organization of the bureau, an immense advance might be made by organizing local predicting bureaus, where the predicting officers could make a closer study of the conditions surrounding them, and gain more time for prediction, instead of, as now, being compelled rapidly to make predictions for almost the entire length and breadth of our land, which is many times larger than any country of Europe, except Russia. The favor with which the Blue Hill predictions, as well as those of others in this and other parts of the United States; have been received, seems proof that local weather bureaus would be at once appreciated by the public."

MENTAL SCIENCE.

The Genesis of Error.¹

PROFESSOR S. EXNER of Vienna contributed to the Congress of German Naturalists and Physicians a very suggestive essay upon the principles underlying the origin of illusion in man and the ani-

¹ From the *Revue Scientifique*, Jan. 12, 1889.

mal world. The physicist, he observes, before deducing any result, takes into account the errors of his instruments. The scientist is always working with one certain instrument, the human mind. The errors of this ever-present factor in all work form a most important field of study.

In the study of instincts, such as those that direct birds in the building of their nests, insects in the formation of their communities, we often admire the wonderful resemblance of these complex acts to the results of reason. And yet we recognize an important distinction between them: their sphere is limited, their power of adaptation to new conditions is small. It is a remarkable mechanism, but has application to a limited number of movements. A bird shows remarkable skill in weaving the threads with which it builds its nest, fastening it to the limb of a tree, and adapting it to the shape of the twig. But tie the foot of a bird in a cage, and it cannot make use of its skill in weaving to untie the fastening, but struggles and flutters until it kills itself or is accidentally freed. Teleologically speaking, certain adjustments are ingrained in its nervous system; but these adjustments are special, not general. The more perfect the instinct, the more stable and invariable is it; the less rigidly the adjustments are ingrained, the more does the act resemble what we term "reason." Diversity and adaptability are the marks of rational development. The weakness of animal intelligence is always in the lack of ability to break away from routine associations; to proceed from two facts to a third. A dog will defend himself if you tease him, but he will not bite. He knows how to use his teeth well enough with his fellows, but towards man he has acquired an attitude of deference.

Animal instincts result from the environment, and must be judged in the environment. When looked at from a human standpoint, these actions seem foolish and irrelevant. We, too, have our rigid instincts, our reflex actions. The closure of the eyelids when an object threatens the eye is a useful protective mechanism; but when we are to undergo an operation, it may be harmful. None the less all the strength of the will is incompetent to keep the eye open. It acts according to its acquired habits. It is true that we are conscious of our error, which animals are probably not; but this is not an essential point. It is proposed to show that the typical kinds of error arise, as do these misapplications of instincts, from the unwarranted application of a general rule to a particular case.

The majority of sense-deceptions support this view. Irritation of any part of the retina arouses a sensation localized in space where an object causing such an irritation would ordinarily be found. In some cases we are freed from illusion by the remembrance of former experiences. Savages are apt to mistake an image in a mirror for a real object behind it: repeated experience allows us to see the image as an image in the plane of the mirror.

Here it is easy to distinguish between the sensory and the memory factors, but in some cases this may be difficult. If you draw a line on a sheet of paper, and cover it up with a second sheet so as just to conceal the end of the line, and show it to some one ignorant of the arrangement, he will be greatly surprised not to find the entire line longer than it is when you remove the second sheet. He does this because it is an uncommon experience to have so little of a line covered up. He cannot help forming a prejudice on the basis of what is most probable. Is this an error of sensation, or of memory?

There are a host of similar deceptions. One need only refer to the tricks of the conjurer. He takes care to appeal to something true as a rule, but false in this particular case. Again: he directs his gaze towards his right hand, infallibly carrying the eyes of the observers to the same spot, while he is performing the trick with the unobserved left hand. Ordinarily we direct our attention to the point of the field of vision in which an action is going on, and we erroneously follow this rule when we should not. We are mechanically obey the general rule as we close our eyelids when an object threatens us.

The illusion consists in the observation of the general to the exclusion of the special. A high intelligence consists in the command of a wealth of associations, and thus a power of distinguishing between the two. A typical instance is that of the host of persons who religiously record the numbers drawn at the lottery, reasoning,

that, inasmuch as all numbers have an equal chance of being drawn, numbers not drawn now must have a greater chance of being drawn later on. In all games of chance one hears the same argument. The luck must change: good fortune must be followed by bad, and *vice versa*. This common error, again, consists in overlooking the particular case; for while, in many cases, such reasoning would be entirely correct, in the case of the lottery and of games of chance it does not hold, because the numbers are all replaced, the cards newly dealt after each issue, thus making the chances of every lucky event just the same as before. It is a confusion of the case in which the ball is returned to the urn with the more frequent cases in which it cannot be returned. Of the same character is the belief in the luckiness or unluckiness of certain players; in the argument, that, because a person has happened to receive more than a normal share of lucky turns, he has a right to expect the continuance of such luck; or, again, the fancied relations between the weather and terrestrial events, etc.: in short, in many kinds of superstition.

More refined examples of the same kind of error can be found in the fields of art and science. When an architect supports a balcony upon two slender iron pillars, it does not appear pretty, because of the disproportion between the supports and the object supported. The origin of this judgment is to be traced to the fact that we have comparatively little experience with the strength of iron, and much experience with the weight of stone. In general, the impression of solidity carries with it the sentiment of beauty; while the use of iron, however convincing the calculations of the architect, does not carry with it this impression. In various forms of art we see the same association between the form and the material used. Our traditions and the experiences of the race thus play a *rôle* in our sentiments, and are a factor in the genesis of error. The Greeks built temples of marble in a style derived from times when wood was the building-material. Returning to science, we may examine the famous argument of Zeno for illustration of our main thesis. Achilles cannot overtake the tortoise if the latter is at all ahead of him, because, while Achilles makes up the distance, the turtle has advanced beyond it; and so on. We get the impression of infinite space by the infinite aggregation of finite spaces, because ordinarily such a sum would be infinite; but here the spaces tend to the infinitely small, and so their sum to a finite quantity. In spite of the ages of discussion spent over this problem, it still remains a real source of error; and from this puzzle of Zeno, down to the blind action of a humble animal, one can trace the genesis of error as a faulty application of a general law to a special case; as the instinctive action of an ingrained nervous adjustment to an environment different from the normal.

ABNORMAL SENSE-ASSOCIATIONS.—Increased attention has recently been given to a class of sensory associations of rare occurrence but extremely interesting. When a certain part of the body is hurt, some persons simultaneously feel a pain in a distant and disconnected part of the body: to these the name of "synalgia" has been applied. They are idiosyncrasies, and are of various kinds. So, too, there are "synaesthesias," or cases of an irritation in one place causing a sensation in another. Dr. Fromental brings these into line with the common experience of sneezing in response to a glaring light stimulation. He does not regard this as reflex, but thinks it psychic in character, and due to the irradiation of a disturbance in the cortex of the brain. The explanation ascribing the connection to an anastomosis between various nerves is also rejected. The peculiar case of hearing colored sounds would also be susceptible to the same explanation. They would be more or less present in all persons, but would only be striking in peculiarly nervous individuals.

BOOK-REVIEWS.

Physical Realism. By THOMAS CASE. New York, Longmans, Green, & Co. 8°.

THIS work contains a criticism of philosophical idealism, or subjectivism, together with the presentation of a new theory which the author offers in its stead. According to the view of Berkeley and his followers, the external world of material things has no real existence, what we call a body being in fact nothing but a cluster of

ideas and sensations in our minds. This theory Mr. Case holds to be contradicted by physical science, which reveals to us certain objects, such as the waves of light, for instance, which are not and never can be objects of sense, but which are nevertheless known to exist. He takes up the works of the leading idealists, and makes an elaborate criticism of their views and of the arguments by which they sought to support them; and this part of his work contains much interesting and useful matter. He rightly regards Descartes as the real founder of idealism, because he assumed that the immediate objects of knowledge are ideas, although he endeavored to reach a knowledge of the external world by inference. This fundamental assumption of Descartes, which has been repeated by every idealist since, is justly treated by Mr. Case as a begging of the whole question; and the passages in which he criticises it are the best in the book. He does not confine his strictures to this one point, however, but deals also with Hume's theory of belief and association, Kant's doctrine of necessary truths, and other topics more or less nearly related to the idealistic view. Some of his remarks, especially on the subjects of induction and necessary truth, seem to us quite as doubtful as those he criticises; but the whole of this portion of his work is well worthy of attention.

Mr. Case has not confined himself, however, to criticism, but has presented a theory of his own in place of the one he criticises; and with regard to this we are obliged to dissent from him. Rejecting idealism as he does, he equally rejects the natural realism of the Scottish school, and maintains that the object of sense-perception is neither an idea nor a body outside of us, but an affection of our nervous system. "The sensible object," he says, "is the nervous system itself sensibly affected. The hot felt is the tactile nerves heated, the white seen is the optic nerves so colored" (p. 24). And again: "I perceive my nervous system, not so far as it is nervous structure moving, but so far as it is sensibly affected in different parts, the optic nerve so far as it is visibly white, the gustatory nerve so far as it is sweet to taste, and so on" (p. 151). Now, we think most people will deny this assertion outright. This reviewer, certainly, is not conscious of perceiving his own nerves sensibly affected, and it was only by studying anatomy that he learned that he had nerves. Besides, what does Mr. Case mean by calling the nervous system, as he repeatedly does, an "internal" object? "Internal," with reference to this question, means "in the mind;" and "external," "out of the mind;" and therefore my own nervous system is just as truly an external object as is the farthest star that I can see. For these reasons we cannot think that Mr. Case has solved the problem of perception.

The Development of the Intellect. By W. PREYER. Tr. by H. W. BROWN. New York, Appleton. 12°.

SOME weeks ago we referred, on its appearance, to the first portion of Mr. Brown's translation of Preyer's great work, "Die Seele des Kindes," and expressed our gratification that it satisfactorily presented to the English reader the results of the Jena physiologist's researches in the field of child-psychology.

The second part, which is before us, is equally well done, and it fully sustains the reputation of the International Education Series, of which it forms Volume IX. A conspectus of Professor Preyer's results, prepared by the translator, greatly increases the value of the book to the average teacher and to the ordinary reader.

The author sees in the power of language and its development the safest and best guide to the tracing of intellectual development, and he traces the growth of this power with great caution and fullness of knowledge. We cannot in this brief space attempt to condense the argument of the book: we must be satisfied to repeat substantially what we said of "The Senses and the Will:" it is a safe companion for any teacher in her study of the unfolding of a child's mental power, and a stimulus to further research and investigation.

Political History since 1815. By CHARLES H. LEVERMORE and DAVIS R. DEWEY. Boston, W. J. Schofield. 8°. \$1.25.

THIS book is an abstract of lectures delivered in the Massachusetts Institute of Technology: hence it is hardly adapted for reading, but it will serve admirably as a guide to historical students, and also to refresh the memory of those who have studied. It

covers the political history of the whole world since the fall of Napoleon, with the exception of the United States, the history of our own country evidently being a separate study in the institute. The selection and arrangement of topics in the book seem excellent; and we are particularly pleased with the small attention given to military affairs, which in some books called histories overshadow every thing else. The opening lecture treats of the various races, governments, and religions of the world; and the remainder of the work presents the recent history of the various nations separately, beginning with England and her empire, and ending with the African continent. The dates of important events are given, and some statistical matter is introduced. A bibliography of the subject is given, and special authorities are cited on all important points. The book is well and carefully printed, and must, we should think, be very useful to students of the field it covers.

Shall We Teach Geology? By ALEXANDER WINCHELL. Chicago, S. C. Griggs & Co. 12°. \$1.

IN this work Professor Winchell sets forth the claims of his favorite science to a more prominent place than it now holds in general education. He first inquires what education is, and comes to the conclusion that it includes both the training of the faculties and the acquisition of useful knowledge. He has an excellent chapter on the faculties themselves; and, while admitting that some of them are better developed by literature or mathematics, he insists that no study will develop them as a whole better than geology. Like most physical scientists, he is severe on the study of languages, especially of Greek and Latin; and, so far as the mere languages themselves are concerned, we incline to agree with him. But language is the medium of literature; and Professor Winchell seems to show an inadequate appreciation of literature, and of the moral and intellectual culture that it gives. But the principal defect of his work is its ignoring of the mental and social sciences. He seems hardly aware of their existence; for he mentions none of them but history, and mentions history only to slight it, declaring that it trains no faculty but verbal memory. His disparagement of history is peculiarly unfortunate, for history is to the evolution of man what geology is to the evolution of the earth and its flora and fauna; and it is surely as important for us to know how man has come to be what he is as to know how the earth's crust has come to be what it is. To this reviewer it seems that the most important study at the present day is that of man, his nature, his duties, and his history; and if this is so, it is hardly possible to give geology so much attention as Professor Winchell desires: for he is not satisfied with a year's study or so, but would have the subject taken up in the primary schools, and pursued every year as long as the student attends school. When we consider that geology is only one science out of fifteen or twenty, and when we further consider the importance of literature and the need of learning foreign languages early in life, it is evident that we cannot give so much time to geology alone. Nevertheless, we are glad to see the claims of the science so well presented, and we hope Professor Winchell's book will be read by educators everywhere.

A Historical Geography of the British Colonies. By C. P. LUCAS. Vol. I. Oxford, Clarendon Pr. 12°. \$1.25.

WE noticed some time ago the little volume introductory to this work, and we are now glad to receive the first volume of the work itself. It contains a little less than two hundred pages, and treats of the European dependencies of Great Britain, and the minor dependencies in Asia and the Indian Ocean. In preparing the work, Mr. Lucas has had the assistance of various persons connected with the governments of the colonies in question, and the portions relating to Malta and Cyprus have been mainly written by one of his associates in the Colonial Office. The work has been prepared with care, and contains a large amount of information in comparatively small space. Each dependency is treated separately, while at the same time their relations to each other and to the home government, and their importance to the empire, are duly pointed out. The history of each is briefly recorded, and sometimes, as in the case of Malta and Cyprus, it makes interesting reading. Then the main geographical features are described, and an account is given

of the people and the mode of government. Most of the colonies, or dependencies, dealt with in this volume are valuable chiefly as naval and commercial stations, this being particularly the case with Gibraltar, Malta, Aden, Singapore, and Hong Kong; but others, such as Cyprus, Ceylon, and Mauritius, have inherent resources of their own. The work shows the immense variety of races, religions, and material interests with which the British Colonial Office has to deal; and this notwithstanding none of the larger dependencies are touched upon. Germans in Heligoland; Spaniards, Italians, Greeks, and Turks in the Mediterranean; Arabs, Negroes, Indians, Malays, and Chinese in the Eastern seas,—all pass in review before us; while the three great religions of the world,—Christianity, Mohammedanism, and Buddhism,—besides minor faiths, are represented. If the work is completed on the plan of this volume, it will be useful not only to geographers, historians, and statesmen, but to all intelligent persons who wish to be informed about the world's affairs.

AMONG THE PUBLISHERS.

ROBERT CLARKE & CO., Cincinnati, O., announce the fifth edition of "Benner's Prophecies," with forecasts for 1889, 1890, 1891. These prophecies are of future ups and downs in prices, and what years to make money on pig-iron, hogs, corn, and provisions, by Samuel Benner, an Ohio farmer.

—The following are from the contents of the *Popular Science Monthly* for March: "New Chapters in the Warfare of Science," by Andrew D. White, LL.D.; "The Chemistry of To-Day," by Professor Ira Remsen; "Glass-Making," by Professor C. Hanford Henderson; "South Slavic Moon-Myths," by Dr. Friedrich S. Krauss; "Competition and the Trusts," by George Iles; "Law as a Disturber of Social Order," by Benjamin Reece; "Among the Fiji Islands," by Coutts Trotter; "The Foundation-Stones of the Earth," by Professor T. G. Bonney; "Natural Science in Elementary Schools," by J. M. Arms; "The Aryans in Science and History," by Horatio Hale; "The Americanists in Congress;" "Sketch of Pierre Belon" (with portrait); also the regular correspondence and editorial departments, literary notices, popular miscellany, and notes.

—The *American Journal of Archaeology*, Vol. IV. No. 4 (Boston, Ginn & Co.) contains "Inedited Terra-cottas from Myrina, in the Museum at Constantinople" (with 2 Dujardin heliotype plates), by Salomon Reinach; "Discoveries in the Attic Deme of Ikaria," by Carl D. Buck, and "A New Sikyonian Inscription," by Mortimer L. Earle, both members of the American School of Classical Studies at Athens; "Early Bronzes discovered on Mount Ida in Krete" (with 5 plates and 4 figures), by A. L. Frothingham, jun., professor of archaeology at Princeton; "Remains of an Ancient Greek Building discovered in Malta" (with ground-plan), by A. A. Caruana, director of education in Malta; notes on the excavation of a Christian palace at Rome, and the existence of America known early in the Christian era; reviews and notices of books on archaeology—general, Oriental, classical, Christian, and prehistoric— and on the Renaissance; archaeological news from Asia Minor, Austria-Hungary, Central America, Colombia, Denmark, Egypt, England, France, Germany, Greece, Hindustan, Italy, Krete, Kypros, Palestine, Phœnicia, Russia, Sicily, Spain, Syria, Tunisia, Turkey, United States, and Wales; and summaries of archaeological periodicals.

—William H. Burnham, Ph.D., late fellow of Johns Hopkins University, will give in the March *Scribner* some valuable practical suggestions to busy men for economy in brain-work.

—The *Contemporary Review* for March (New York, Leonard Scott Publishing Company) will contain an important paper on the Panama Canal by the eminent traveller, Mr. Edward Wymper, illustrated by a large chart of the scene of operations, etc. An interesting and full *résumé* of the financial condition of the Canal Company appeared in the *Nineteenth Century* for February, 1888, which is particularly valuable, in view of the recent collapse of the enterprise.

—Probably the most interesting paper in the *Scottish Review* (New York, Leonard Scott Company) for the present quarter is a translation of Ivan Turgenieff's weird story of the "White Lady."

The spirit which forms the central figure in this extraordinary play of the imagination belongs to a class which appears more frequently in the popular beliefs of Russia than in those of other countries. It is, however, not unknown in Scotland. Sir Walter Scott's ballad of "Glenfinlas," for example, is based upon a legend of a young man killed by a being of this sort,—a catastrophe which Turgenieff has obviated or postponed by the use of a peculiar expedient.

—No less than eight editions have been called for of the *Contemporary Review* for February, containing the remarkable article on the Bismarck dynasty. This article is said to be circulating freely in Germany.

—"England and Germany in East Africa" forms the subject of the opening paper in the *Fortnightly* this month. Professor Dowden writes on "Hopes and Fears for Literature;" Mr. Swinburne continues his notice of Victor Hugo's poetry; Professor Tyndall furnishes another instalment of his articles on "English Light-house Management;" Dr. Ingram writes on "Two Centuries of Irish History;" and Mrs. Lynn Linton begins her series on "Characteristics of English Women." Among the other articles, the unsigned one on the "Trade of Author" will probably attract most attention.

—The February number of the *Modern Science Essayist* contains "Solar and Planetary Evolution," an essay by Garrett P. Serviss, together with criticisms on the essay by R. G. Eccles, M.D., Professor Van der Weyde, and L. G. James, M.D.

—The "Truth Seeker Annual" for 1889 contains a fine picture of the statue of Giordano Bruno, soon to be erected in Rome, and two illustrations showing the Lick Observatory and its great telescope.

—During the session of the Electric Light Convention at Chicago last week, the *Western Electrician* issued a daily edition, containing full reports of the proceedings.

—Col. T. W. Higginson's poems, which Longmans, Green, & Co. are about to publish in New York and London, are dedicated to J. R. Lowell, "schoolmate and fellow-townsmen." The volume is called "The Afternoon Landscape," for the morning of the poet's life is now past. The poems include the sonnet to "Duty" and the lighter stanzas on "A Jar of Rose-Leaves." Among the translations are Sappho's "Ode to Aphrodite," and a dozen sonnets from Petrarch and Camoens.

—"Micah Clarke: his Statement" is the title of an autobiographic tale of Monmouth's rebellion, which is soon to be published by Longmans, Green, & Co. It is rather a narrative of personal adventure than a romance, yet the author's art recalls both "Lorna Doone" and "Kidnapped." This is a tale of adventure, full of strong incident and vigorous character-drawing, with not a little incidental humor. Saxon is a younger brother of Dugald Dalgetty, and quite as delightful in his professional pride.

—The *Political Science Quarterly* for March opens with a striking article by H. L. Osgood, upon "Scientific Anarchism," reviewing the theories of Proudhon, and showing the aims of American anarchists. Professor Gustav Cohn of Göttingen, taking the progressive income taxes of Switzerland as his text, indicates the merits and the dangers of this democratic scheme of taxation. Mr. Arnold Forster (son of the late Irish secretary) presents forcibly the Unionist view of the Irish question. A conservative Frenchman, M. Gauvain, explains the causes of the present crisis in France, and the significance of "Boulangism." Mr. Bernheim sketches the history of the ballot in New York, and argues for the Australian System. Professor Woodrow Wilson analyzes and criticises Bryce's "American Commonwealth." The June number will contain an article by Professor Sloane of Princeton, editor of the *New Princeton Review*, and will continue and bring down to the 1st of May the "Record of Events" heretofore published in the *New Princeton Review*.

—W. J. Schofield, 105 Summer Street, Boston, Mass., has published "Political History since 1815 (excluding the United States)." This syllabus of lectures upon modern political history, prepared originally for use in the Massachusetts Institute of Technology, by C. H. Levermore, assistant professor of history, and D. R. Dewey,

assistant professor of economics and statistics, presents a skeleton of nineteenth century history down to 1889, and is based on copious references to standard works, and to important articles in the leading reviews.

— John Delay, New York, calls attention to the fact that the volumes in his new library of Gleanings from Foreign Authors are to be published at 30 cents, instead of 50 cents as previously advertised.

— Apropos of the arrival in the American market of his "Souvenirs d'un Homme de Lettres," it is said that Daudet is suffering from a hopeless nervous malady of the kind which wrecked Heine's life, and it is feared he may not be able to accomplish much more work.

— Mr. Ivan Panin, Wellesley, Mass., will print his lectures on Russian literature, delivered before the Lowell Institute, Boston, in a style uniform with his translations from Pushkin, as soon as he procures enough subscribers at \$2 per volume. Names should be sent to the above address before April 1.

— *The Publishers' Weekly* announces that Mr. Samuel C. Eastman of Concord, N.H., while spending the summer in Denmark, translated, under the author's encouragement and supervision, Dr. George Brandes' "Impressions of Russia." Dr. Brandes was invited to deliver a course of lectures in French before the literary clubs of St. Petersburg and Moscow, and while there he was given remarkable facilities for studying the people and institutions of the country. His views are extremely lively and entertaining, and his frankness of criticism is so pronounced that the book was placed on the black list by the censor. The chapters on Russian literature are fresh and full of information, and the work is a decided addition to our knowledge of an extraordinary country. Mr. Eastman's translation will be shortly published by T. Y. Crowell & Co.

— The *Forum* for March begins its new volume with an article by Cardinal Manning, showing the evils of compulsory education, and opposing the reading of the Bible in the public schools. Dr. George P. Fisher of Yale University will write a refutation of Cardinal Manning's conclusion. A paper by Professor W. S. Scarborough, a negro, will explain the aspirations and hinderances of the negro in the South.

— Peter Paul & Brother, Buffalo, will publish immediately "The Champions of Agrarian Socialism, and their Teaching," from the German of the Rev. V. Cathrein, S.J.

— Brentano Bros. announce that they will publish shortly "Where the Trout Hide," giving a detailed description of a newly opened, easily accessible, and beautiful country, whose waters teem with brook trout, black bass, and land-locked salmon, by Kit Clarke, an angling enthusiast.

— It is said that Mr. Du Chaillu's book on the Norsemen has practically been reset for the sixth time, the author having made discoveries and revisions which involve important changes and additions. The whole work, which has 1,200 beautiful illustrations, will probably appear next month.

— A volume which promises to be of interest to Scotsmen and their descendants in this country will shortly be issued from the office of the *Scottish American*, New York. It contains a series of essays illustrative of Scottish life, history, and character, gathered together under the title of "Scotland and the Scots." The author, Mr. Peter Ross, has long been a diligent student of the history of the Scottish race on this side of the Atlantic; and in the opening essay, "The Scot in America," is given a succinct account of how the people of that nationality have aided in all the religious, military, educational, national, political, and other movements which make up the history of North America. Among the other essays are "The Scot Abroad," "Scottish Characteristics," "Scottish Sports," "Scottish Superstitions," and "Freemasonry and Robert Burns."

— J. B. Lippincott Company have in press the third revised and rewritten volume of "Chambers's Encyclopædia," which will be complete in ten volumes; a "Life of Henry M. Stanley," by Rev.

H. W. Little; and "Examples, Rules, Tables, and References" for engineers, etc., by John Richards (subscription). They will also add to their medical list a "Cyclopædia of Diseases of Children," edited by Dr. J. M. Keating, to be in four volumes, sold by subscription; a new edition of the "Elementary Treatise on Human Anatomy," by Professor Joseph Leidy; "The Clinical Diagnosis of Non-Surgical Diseases," by Dr. Rudolf von Jaksch of Vienna, translated by Dr. Cagney of London; and a fifth volume in their "Practical Lessons in Nursing," devoted to "Diseases and Injuries of the Ear."

— A. Flanagan, 185 Wabash Avenue, Chicago, has issued a game of cards entitled "Literary Whist, or, Games of Great Men," prepared by N. O. Wilhelm. In playing the dozen or more games that may be played with these cards, it is expected that one may soon become acquainted with the lives, the works, and the characteristics of the world's greatest poets, prose writers, statesmen, warriors, scientists. Most of the games are simple enough for a child, or may be made abstruse for the learned. The set consists of 100 cards, $3\frac{1}{2} \times 2\frac{1}{2}$ inches. There are 26 "books" to be made or obtained. These are of poets, indicated by key-word P.; prose writers, key-word P.W.; soldiers, So.; statesmen, St.; scientists, Sc. Contemporaries of the same class are in the same book. Prominent traits and works are given with each name, so that in playing these games one acquires valuable knowledge while passing away a pleasant hour.

— Dr. H. A. Hare of the University of Pennsylvania has issued through P. Blakiston, Son, & Co., Philadelphia, his essay on "Mediastinal Disease," to which the Medical Society of London awarded the Fothergillian medal for 1888.

— Henry Worthington, 88 Liberty Street, this city, announces that he will furnish free, upon application, a handsomely illustrated catalogue descriptive of steam-pumps, pumping-engines, and hydraulic machinery.

— We learn from *Engineering* that the long-continued experiments which have been conducted on board the "Nettle" at Portsmouth, with the view of determining the respective merits of compound armor and of solid steel armor as a protection for battleships, have just been brought to a close. Only two Sheffield manufacturers sent in compound samples for competition; but the number of steel plates forwarded for trial amounted to eight, from as many makers, being two less than were expected. The ten-inch plates were attacked by steel and Palliser projectiles, at a range of thirty feet; and although two of the solid steel armor-plates, at least, underwent the crucial ordeal with satisfactory results, the superiority remained with the steel-faced armor now adopted in the English Navy.

— In experiments recently made in France on the elasticity of cork, it was found that disks of that substance, when submitted to a pressure of 1,100 kilograms per square centimetre, were compressed to one-fifth their thickness, and recovered their original dimensions in exactly ten minutes after the pressure was removed.

— The announcement recently made, that Professor Kruss of Munich had succeeded in decomposing nickel and cobalt, proves to be erroneous. What he has really done is to obtain from these two elements a third one, which existed in them as an impurity.

— In the March *Atlantic*, history is possibly the strong point, there being a paper on those two brave Scots, "The Keiths," by Hope Notnor, and one of Mr. Fiske's papers upon "Ticonderoga, Bennington, and Oriskany." Mr. Frank Gaylord Cook writes an article upon "Some Colonial Lawyers and their Work;" while a theme of a more recent day is treated in "Personal Reminiscences of William H. Seward," by Samuel J. Barrows, and his wife Isabel C. Barrows. The paper is especially interesting, since Mr. Barrows was private secretary to Mr. Seward, and Mrs. Barrows also acted temporarily in the same capacity. In this connection, Stuart F. Weld's consideration of "The Isthmus Canal and our Government" should be mentioned, and a review of Professor Bryce's book on "The American Commonwealth." Mr. James's serial, "The Tragic Muse," abounds in studies of personality, and Mr. Hardy's "Passe Rose" is interesting. The first part of a negro story called

"Hannah Calline's Jim," and an essay on "Simplicity," by Charles Dudley Warner, close the prose articles; and the poetry includes Mr. Whittier's "The Christmas of 1888," and verses by E. Wilson.

LETTERS TO THE EDITOR.

* * *Correspondents are requested to be as brief as possible. The writer's name is in all cases required as proof of good faith.

Twenty copies of the number containing his communication will be furnished free to any correspondent on request.

The editor will be glad to publish any queries consonant with the character of the journal.

The Soaring of Birds.

SINCE my paper was reported in *Science* (xii. p. 267), Messrs. Oliver, Pickering, and MacGregor have favored the journal with letters on the subject.

Professor Oliver (xiii. p. 15), while admitting that the action I suggest is to some extent efficient in sustaining the bird, questions its sufficiency. I had asked the same question myself, and found no answer; but I am glad to know, through private correspondence, that Professor Oliver and at least one other physicist are disposed to put the question to nature through experimentation.

Professor Oliver also suggests minute vibratory motions of the wings, or perhaps of the individual wing-feathers, and cites an observation by another. The same hypothesis was advanced in explanation of the allied phenomenon of hovering, but was rejected on the strength of what seemed sufficient observation (*Nature*, viii. p. 324; ix. p. 5). The hovering bird remains in one place for so long a period that he can be deliberately and carefully watched.

Mr. Pickering and Professor MacGregor each proposes an explanation different from mine, and not involving differential air movements, but appealing instead to a homogeneous and uniform wind. Their conception of relative velocities is so different from mine, and I am so confident in the correctness of my own, that I am led to suspect I have not made my meaning clear, and I therefore ask the privilege of restatement.

As I conceive the matter, the horizontal velocity of the bird with reference to the earth has no importance, and should be ignored. The earth enters the problem only by means of its attraction. Except for the gravitational pull, we need not consider the bird in relation to anything except the air. If a cloud intervened between the bird and the earth, so that he could not see the ground, he would not know in which direction the air surrounding him was passing over the earth; but the possibility of his soaring would not be affected by that ignorance. Provided the air in which the bird floats is not disturbed thereby, his motions would not be affected by the sudden reversal of the direction of rotation of the earth, although such a reversal would enormously change the relative velocity of bird and earth.

In my analysis of the subject I spoke of winds, that is, currents of air moving horizontally with reference to the earth, because such language afforded me a simple means of expression, and for that reason only. In so doing I took a special case as illustrative of the general case. As this seems to have been misunderstood by some of your correspondents, I will repeat the analysis in more general language.

Let the line AB represent in section a horizontal plane within the atmosphere. Conceive the body of air above this plane and the body of air below it to have different motions, such that their differential motion has the direction indicated by the arrows; that is

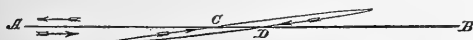

to say, the upper body referred to the lower moves from B to A , or the lower body referred to the upper moves from A to B . The movement of the two bodies collectively may be in any horizontal direction. They may both move toward A , the upper moving the swifter. They may both move toward B , the upper moving the slower. Either may be still and the other move past it, or they may move in directions approximately normal to the paper. My only postulates are, that their motions have no vertical component, and that their differential motion, z , has the direction expressed by the arrows.

The oval curve represents the assumed orbit of the bird as presented to an eye nearly in its plane. The bird ascending on one side of this orbit through the point C has, just before reaching that point, a velocity V as referred to the lower body of air, in which it is then moving. Immediately after passing C , his velocity referred to the upper body of air, in which he is then immersed, is $V + z$. He moves faster in the upper air, because when he enters it his direction is opposed to the direction of the differential motion of the upper air referred to the lower. His absolute motion both before and after passing the plane of separation is the same; but his relative velocity, that is, his velocity referred to the air through which he is passing, has been increased by the quantity z . Continuing on his circling orbit, he first ascends and then descends, reaching the plane of separation at the point D . While he ascends, gravity retards his motion; while he descends, his motion is accelerated by gravity to the same extent; so that he returns to the plane at D with the same velocity ($V + z$) with which he left it at C . He now passes from the upper body of air to the lower body in such direction that he again increases his relative velocity. As soon as he has passed D , his velocity referred to the lower air is $V + 2z$. Continuing to C , he first descends and then ascends, his velocity being first accelerated by gravitation, and then retarded by the same amount; so that he reaches C with the velocity $V + 2z$, in place of the previous velocity V , having gained the velocity $2z$ by passing in suitable directions to and fro between the differentially moving bodies of air.

The various qualifications of this theorem, and its relation to the problem of soaring, need not be repeated here. All that is now attempted is to show that the essential parts of the analysis are absolutely independent of the direction and velocity of air movement as referred to the ground.

It appears to me that Mr. Pickering and Professor MacGregor, by referring the motions of the bird partly to the ground and partly to the air, engender confusion, and are led to assume untenable positions. Mr. Pickering (xiii. p. 31) says that a piece of paper floating on the air is carried along horizontally with the velocity of the wind, but that a soaring bird does not drift so fast. Then, to account for the floatation of the bird, he appeals to the "force exerted on him by the wind, owing to the fact that he does not move along as fast as the surrounding air." Thus he assumes a force tending to prevent the bird from drifting horizontally with reference to the earth; and this assumption reduces the problem to practical identity with the problem of the ascent of a boy's kite. In point of fact, the assumed force does not exist: the only re-action between the bird and the earth is through gravity, and the direction of gravitation is vertical. If it be true that the soaring bird drifts less rapidly than the piece of paper, the explanation lies in something that the bird does; and that thing, whatever it is, costs energy. Appealing to the bird's net movement against the wind as a source of energy merely shifts the point of difficulty, for his net movement against the wind must then be explained.

Professor MacGregor says, "Let us suppose, now, that a bird is at any instant moving horizontally, in the same direction as the wind, and with a small velocity relative to the earth. . . . As his speed increases, the velocity of the wind relative to him diminishes" (xiii. p. 152). Now, if the velocities of bird and wind relative to the earth are so related that increase of the bird's speed diminishes the velocity of the wind relative to him, then it must be that the wind is moving faster than the bird, or is overtaking him. The context shows that Professor MacGregor conceives the bird to face in the direction toward which the wind blows, and it follows that with reference to the air the bird is moving tail first. I am confident that no ornithologist will admit the possibility of such flight; and its implicit postulation could hardly have occurred had the problem been stated wholly in terms of bird and air instead of being stated partly in terms of bird and ground. A little further on he says, "Let us suppose that in wheeling he maintains his velocity relative to the earth as well as his elevation. Then [after wheeling], starting upwards with a considerable velocity, he will clearly be able to rise through a certain height before his velocity has been reduced to its initial value." The assumption that the bird in wheeling maintains his velocity relative to the earth

appears to me absolutely groundless. The only velocity that can possibly remain constant, or approximately constant, during wheeling, is the velocity with reference to the supporting medium; and as that velocity is, according to his previous assumption, not only small, but negative, there is no energy available to enable the bird to rise. Indeed, the bird, in passing from a negative velocity relative to the air, to a positive velocity relative to the air, must pass through the phase of no velocity relative to the air, in which he is practically helpless, being compelled to fall vertically in order to acquire sufficient speed to steer. Like Mr. Pickering, Professor MacGregor treats the subject as though the earth influenced the motions of a bird on the wing by some other means than gravitational attraction. He apparently fails to perceive, that, if the body of air in which the bird moves has no internal motion, its relation to his flight is precisely that of a calm.

Let me illustrate. A steamer propelled with uniform force on a calm ocean has its rudder turned constantly, and by the same amount, to the right, and consequently describes a circle. This circle is described *on the ocean*: it expresses a relation between the moving body and that by which it is supported. It has no reference to the bottom of the ocean. It makes no difference whether that part of the ocean is at rest or is part of a swift current. The relation of the boat to the water is not affected by the relative motion of water and bottom. Or consider a skater. Having acquired momentum, he is able to describe circles without propulsive effort until the stored-up energy is consumed by friction and by the resistance of the air. The ice on which he circles may be frozen to the shores of a pond, or it may float with uniform speed on a rapid river; but his relation to the ice is the same in either case, and his circles have the same pattern as *engraved on the ice*. The case of the soaring bird is closely analogous. His horizontal motions are related only to the air in which he moves, and by which he is supported, and they are not affected by the uniform horizontal motion of that air with reference to the ground.

A slight correction, and I have done. I assume, as Professor MacGregor says, that after wheeling, the bird's velocity relative to the medium in which he turns will be the same as before (discounting friction); but I do not admit the implication "that during the turn his velocity relative to the earth will change by an amount equal to twice the velocity, relative to the earth, of the medium in which the turn is made." His velocity relative to the earth will change by an amount equal to twice his velocity relative to the medium.

G. K. GILBERT.

Washington, D.C., Feb. 25.

In two communications published in the last number of *Science* (p. 151) under the above title, Professor Pickering and Professor MacGregor have developed with considerable ingenuity a theory of the possibility of a bird soaring in a uniform horizontal wind; but it is certainly true that a bird cannot soar — that is, permanently sustain or elevate itself without expending energy — in such a wind, and it has therefore seemed to me to be important, in the interests of clear thinking, to show on dynamical grounds why soaring is impossible in this case.

Evidently the velocity of the wind relative to the earth has nothing to do with the question, as it is the relative movement of wind and bird that causes the re-actions between them, and therefore can alone come into consideration. Let the air, therefore, be supposed to be at rest relative to the earth, and it becomes at once obvious that the bird cannot soar: for, suppose the bird to have any imaginable initial velocity, and to wheel in the most artful manner, it is still a mass falling under the influence of gravity, and only resisted more or less by the fluid friction of the medium in which it is placed. This fluid friction of the air against its wings can only delay its fall, but can never prevent it, just as it delays the fall of a feather.

A theory of soaring must explain how energy is given to the bird by the wind; but it is clear, that, instead of the bird receiving energy, it is expending either its kinetic energy, as when in one of its whirls it sweeps upwards, or potential energy when it sweeps downwards. But the temporary increase of potential energy in a rise can never equal the corresponding loss of kinetic energy, because energy is being continually expended in frictional heating. There is thus a steady expenditure of energy, and none received

from the medium, and the bird is therefore bound to come to the ground. The only effect of the medium is to resist the motion, in whatever direction it may take place, whether up or down.

As soon as it is clearly seen that the only thing we are concerned with is the relative motion of air and bird, and that the air may be at rest relative to the earth without affecting the question in the slightest, the futility of any attempts to explain soaring in a uniform horizontal wind is apparent.

If any one wishes to discover the particular fallacies in the theories above mentioned, let him attempt to follow out the reasoning as given in the communications referred to; assuming, however, that there is no wind, that the air is at rest relative to the earth; remembering that the mere fact of the earth's moving relative to the wind has no connection with the relation between the bird and the air.

The theory that soaring can be kept up by taking advantage of differentially moving layers of air is not open to the above criticism, and may be the true explanation: it is certainly not unreasonable on its face.

ARTHUR L. KIMBALL.

Johns Hopkins University, Baltimore, Feb. 25.

To keep Water-Mounts Moist.

In biological work with the microscope it is frequently desirable to preserve water-mounts for several days, that growth, development, etc., may be observed from time to time. Water lost by evaporation can be very successfully replaced to the glass slips from a beaker beneath by means of capillary tubes. To make these, hard-glass tubing of about three millimetres bore is softened in a Bunsen flame, and then drawn out to a diameter of from two-tenths to three-tenths of a millimetre. This is then divided up into lengths of five centimetres, and each piece bent at an angle of about 80° one centimetre from an end by holding it over a very small flame for an instant, when, of its own weight, the end falls to the proper angle. One tube is sufficient for a slip, and is applied by first touching the longer limb in water, when instantly the liquid will rise and fill the tube, which may now be suspended by the shorter portion from the glass slip, allowing one end to just touch the edge of the cover-glass, and the other to dip beneath the surface of the water in the beaker. A thin film of water will run along the shorter limb, and hold it securely in place. The whole is then covered with a suitable bell-jar. In this way mountings in water or nourishing solutions may be kept an indefinite time, and are always ready for examination without disturbing them in the least. Should it be desired to supply more fresh water or nourishing solution to the mount than would ordinarily arise, a bit of filter-paper applied to the side of the cover-glass opposite the capillary tube will accomplish this.

E. B. KNERR.

Parsons College, Fairfield, Io., Feb. 28.

Color-Blindness a Product of Civilization.

THE following is a summary of a paper read before the Kansas Academy of Science at Leavenworth, Nov. 1, 1888:—

The fact that blindness to certain colors exists among civilized people is well established; also the percentage of cases to be found among males has been determined with considerable probability for the races of Europe and America. There has been much diversity in methods of testing, and the results of many reported determinations might well be called into question. Still it is probably not far from the truth that about four out of every hundred males are more or less deficient in color-sense. Of females there have been reported (B. J. JEFFRIES, M.D., *Color-Blindness*, p. 74) as examined in Europe and America 39,828; and of these, only 60 were color-blind, or 2 per cent. Of both males and females, 156,732 have been tested; and of these, 6,721, or 4.27 per cent, are color-blind. These statistical facts have naturally excited interest and discussion. If so large a number as four out of every hundred are unable to distinguish colors, there arises, of course, a practical question important to the railroads, marine, etc.

The gravity of this fact is already recognized more or less in all countries by the test examinations for color-blindness among employees. But there is in these statistics also much of interest to scientists.

Most cases of color-blindness are found to be congenital, and are incurable. Many have been produced by disease, some by violent concussions in accidents, and some by excessive use of tobacco and alcohol. Temporary blindness to violet may be induced by santonine. From these facts several interesting questions have suggested themselves to us. If color-blindness follows the law of heredity, is it on the increase, or decrease? Further, is it a product of civilization? The first of these queries can be answered only by statistical data extending over long periods of time. The second naturally suggests a comparison, first, of the color-sense of civilized nations among themselves; and, second, of civilized with uncivilized peoples. Of tests in native tribes, we can find but two recorded,—those of Dr. Favre on some tribes in Algiers, and those of a Dr. Fox on 150 American Indians, but where we do not know.

First, for the comparison of civilized tribes among themselves, we have calculated the following percentages from tables reported by Dr. Jeffries:—

	No. Examined.	Per Cent Color-blind.
Austria.....	5250	3.79
Denmark.....	5840	3.74
Belgium.....	8106	4.13
Holland.....	2300	1.43
Finland.....	1200	5.00
Norway.....	205	4.88
Sweden.....	32504	3.73
Switzerland.....	3024	5.36
Germany.....	6344	4.12
Russia.....	12830	3.30
Italy.....	2065	2.32
England.....	16431	3.75
United States.....	44844	3.64
Average per cent.....		3.76

No great reliance can be placed upon these results. The numbers examined are too small, the methods of testing not uniform, not equally reliable. However, the probabilities of error are about equally distributed; so that the conclusion is fairly well established, even without great accuracy of data, that among civilized nations color-blindness is at present almost equally common.

Second, among uncivilized people, Dr. Favre's results from Algiers, already alluded to, show 414 examined, and only 2.6 per cent color-blind. Dr. Fox reports 161 young Indians tested, and only 1.81 per cent color-blind. These percentages, so low compared with those for civilized people, suggested to us that color-blindness may be a product of civilization, and have led to our tests here reported. At the Haskell Institute at Lawrence, Kan., are several hundred Indians, representing many tribes. These we have recently examined by Holmgren's method with Berlin wosteds. Out of 418 tested,—285 males and 133 females,—only three cases of color-blindness exist, or only .7 of one per cent. These three are full blooded Indians of the Pottawattamie, Pawnee, and Crow tribes. Of these, two have defective color-sense for red, and one for green.

The Indians of the school are about equally divided as full-bloods and half-breeds. It seemed to us that the half-breeds showed more instances of blunted color-sense than the full-bloods. This was evidenced in more frequent and prolonged hesitation among them in comparing the colors than among the full-bloods. If this was confirmed by more extended examinations, it would, in conjunction with the low percentages obtained as above, be an argument in the theory proposed by us that defective color-vision is in some way the product of civilization.

The use of tobacco suggests itself as a possible cause. This would explain also the low percentage among females. It leads also to the thought of increase of color-blindness in males in future

generations. But the data are at present too meagre to more than suggest this explanation.

It is certainly not accidental that nearly every case of color-blindness is for red, few for green, and seldom one for violet. Why are the defects thus limited, at present at least, to the longer wavelengths of light?

The Young-Helmholtz theory of color-perception will locate the affection in that layer of the retina corresponding to the first of the three primary sensations of color. But why this special layer, with few exceptions, is the only one affected, has at present no explanation.

The law of heredity indicates increasing sensitiveness in those nerves which are subjected to special use through many generations. It seems reasonable to look for an explanation of the more perfect color-sense in females to this fact; but among males there will probably be an increase, in future generations, of the number of cases of defective color-sense.

L. I. BLAKE.
W. S. FRANKLIN.

Lawrence, Kan., Feb. 19.

Note on the Wind-Pressure Constant.

THERE is a very old formula in use among English and American engineers and meteorologists for obtaining the force of the wind from its velocity. The product of the square of the wind's velocity in miles per hour into the factor .005 is taken as the pressure in pounds upon each square foot. It is used alike at sea-level and on the tops of high mountains, and in the extreme temperatures of winter and of summer, notwithstanding the pressure must vary as the density of the air. This is the value of the factor determined by Rouse from experiment about one hundred and fifty years ago, and of all the crude experiments which have been made from that time to this, and before. It seems to be an extreme value. Of a number of the older determinations of this factor, it is stated, in Gehler's "Physicalische Wörterbuch," that this is the worst, while those of Hutton and Woltman are perhaps not much in error. It is astonishing to see, therefore, with what tenacity engineers and meteorologists still hold on to this factor. It has been maintained by the writer for several years that this factor is much too large,—first in *Van Nostrand's Journal*, 1881; then in "Recent Advances in Meteorology;" and in the *American Meteorological Journal*, 1887. It was shown that the theoretical value of the factor, not considering friction, is .0027; and it was thought that this could not possibly be increased to .005 by the friction of the air. And it was shown that this view of the matter is confirmed by Loomis's results obtained from the discussion of experiments made by the request of Newton in St. Paul's Cathedral, London, upon the velocity of the falling of hollow glass globes and of bladders, and of Hutton's experiments with a whirling-machine. From all these researches, and also the somewhat recent experiments of Hazen with a whirling-machine, it was concluded that the theoretical constant above could not be increased by friction more than one-tenth, or, at most, one-eighth part. But the old factor has been in use so long, that conservatives think it must be correct, and so are unwilling to give it up.

A further confirmation of the erroneousness of the factor is now found in the last number of the *Quarterly Journal of the Royal Meteorological Society*, which contains a report from the wind-force committee appointed by that society. The committee, as yet, have made only a few preliminary experiments in this part of their work; but the average value of the factor from these is .003, which is about one-tenth part greater than the theoretical value given above. This will, no doubt, be changed a little in their final report, after more experiments shall have been made; but as it agrees nearly with the factor obtained by Hazen, and with what is to be inferred from other experiments, it is not probable that the final result will vary much from this.

This is a factor in which engineers are especially interested, and its value ought to have been accurately determined by them long ago; but, as the Royal Meteorological Society has now taken it in hand, it is to be hoped that its committee will do the work thoroughly, as they apparently intend to, and determine the value of this factor accurately, not only for plates of different sizes and shapes, but also for different temperatures and barometric pressures.

W.M. FERREL.

Kansas City, Mo., Feb. 20.

Publications received at Editor's Office, Feb. 17-23.

- ALDEN'S Manifesto Cyclopaedia of Knowledge and Language. Vol. XI. Debt to Dominic. New York, J. B. Alden. 128 pp. 50 cents.
BINKY, A. The Psychic Life of Micro-organisms. Tr. by Thomas McCormack. Chicago, Open Court Publ. Co. 120 p. 125 pp. 75 cents.
BURNER, H. C. A Woman of Honor. (Ticknor's Paper Series, No. 52.) Boston, Ticknor. 359 p. 160 pp. 50 cents.
FOLIE, F. Annuaire de l'Observatoire Royal de Bruxelles, 1886. Bruxelles, F. Hayez. 435 p. 24".
GOSSE, E. A History of Eighteenth Century Literature (1660-1780). London and New York, Macmillan. 415 p. 128 pp. \$1.75.
HAWTHORNE, N. Tales of the White Hills, and Sketches (Riverside Literature Series, No. 40.) Boston and New York, Houghton, Mifflin, & Co. 95 p. 160 pp. 15 cents.
IVES, E. A. New Principle in Heliocrony. Philadelphia, The Author. 23 p. 80.
JACKMAN, W. S. Practical Lessons on Plants. Boston, N. E. Publ. Co. 53 p. 16".
LEVERMORE, C. H., and DREWY, D. R. Political History since 1815 (excluding the United States). Boston, W. J. Schofield, Pr. 416 p. 80 pp. \$1.25.
LITERARY Companion. The Vol. I. No. 1. Kansas City, Kan., W. H. Plank. 4 p. 4 pp. 25 cents per year, single number, 3 cents.
LUCAS, C. P. A Historical Geography of the British Colonies. Vol. I. Oxford, Clarendon Pr. 191 p. 128 pp. \$1.25.
PILLING, J. C. Bibliography of the Inroquoian Languages. Washington, Government, 190 p. 80.
PREECE, W. H., and MAIER, J. The Telephone. London, Whitaker & Co.; New York, VanNostrand. 429 p. 128 pp. \$1.
PREYER, W. The Mind of the Child. Part II. The Development of the Intellect. Tr. by H. W. Brown. New York, Appleton. 317 p. 12".
SMITH, C. L. The History of Education in North Carolina. Washington, Government. 179 pp. 32.
WINCHELL, A. Shall We Teach Geography? Chicago, S. C. Griggs. 217 p. 128 pp. \$1.

D. APPLETON & CO. PUBLISHED THIS WEEK:

Mental Evolution of Man:

THE ORIGIN OF HUMAN FACULTY. BY GEORGE JOHN ROMANES, F.R.S., author of "Mental Evolution in Animals," etc. One vol., 8vo, cloth. Price, \$3.00.

This work, which follows "Mental Evolution in Animals," with the same author, considers the probable mode of genesis of the human mind from the mind of lower animals, and attempts to show that there is no distinction of kind between man and brute. It is likely to provoke no little discussion in the religious and literary as well as the scientific world.

"The vast array of facts, and the sober and solid method of argument employed by Mr. Romanes, will provide, we think, a great gift to knowledge."—Saturday Review.

The Folk-lore of Plants.

By T. F. THISELTON DYER, M.A. 12mo. cloth. Price, \$1.50.

"The Folk-lore of Plants" traces the superstitions and fancies connected with plants in fairy-lore, in witchcraft and demonology, in religion, in charms in medicine, in plant language, etc. The author is an eminent English botanist, and superintendent of the gardens at Kew.

1, 3, & 5 Bond Street, New York.

SPECIAL TEACHER'S EXCURSION TO PARIS EUROPE AND THE WORLD'S EXPOSITION, visiting England, France, Germany, the Rhine, Belgium and Holland. All travel and hotels FIRST-CLASS. Finest line of Steamers crossing the Atlantic. Low Rates. Rooms are being rapidly taken. Send for circular free. E. TOURJEE, Franklin Square, Boston, Mass.

STAR ATLAS.

Containing Maps of all the Stars from 1 to 6.5 magnitude between the North Pole and 34° South Declination, and of all Nebulae and Star-Clusters in the same region which are visible in telescopes of moderate power. With Explanatory Text, by Dr. HERMANN J. KLEIN. Translated and adapted for English Readers, by EDMUND McCLEURE, M.A., M.R.I.A. 18 Charts and 84 pages of illustrative letter-press. Imperial 4to, cloth. \$2.25 net. If by mail, 20 cents must be added for postage.

"I have been looking for just such an Atlas for more than thirty years. The absence of those historical charts which adorn most all star maps and every celestial globe is certainly a great loss. The astronomer wants the outlines only of the constellations on his star-maps. The insertion of Nebulae and star-clusters visible in small telescopes only, is a boon to the astronomer who does much work (or any) in searching for Comets; and as this work is mostly done with small telescopes the ob- ject will have little value."—H. P. TUTTLE, M.A., formerly of the Cambridge (Mass.) Observatory.

"I have carefully examined the Star Atlas... and consider it in every respect a first class work... The maps are clear, distinct and remarkably accurate, the boundaries of the constellations agree exactly with the very best authorities; the names are marked distinctly. The Nebulae and star-clusters are all marked and carefully named down to such a magnitude as could be seen with an ordinary two or three-inch telescope, and their positions are remarkably accurate. The descriptions of astronomical phenomena are given by the best authorities and with the heavens; they are accurate and just as exhaustive as possible for the space. The pictures of some of the most important phenomena are derived from the best sources, some of them excellent copies, and others quite accurate representations of the heavens. The whole work was written by an astronomer of acknowledged reputation, which itself is a sufficient recommendation. The book is very handy and it surprises me how much is contained in such a small compass; it is practical, for no stars or other objects are put down below a certain limit, and it is practically exhaustive up to that limit. There are three classes of people that it may benefit. 1. Astronomers who are particularly engaged in comet hunting; on account of the Nebulae being marked as they are. 2. Amateurs with two or three inch telescopes who want to get a general view of the sidereal heavens. 3. Students for I think a copy of this Atlas would be extremely useful as a hand-book where sidereal astronomy is taught in any manner. It gives me great pleasure to state that I do not know of any book of its kind that contains so much accurate knowledge in so small a compass."—EDGAR KRISBY, Professor of Mathematics, U. S. Navy. U. S. Naval Observatory, Washington, D. C.

E. & J. B. Young & Co.,

COOPER UNION, FOURTH AVE., NEW YORK.

Schools.

THE CHESTNUTS.—Parents with daughters to educate, or orphan girls with companion, may find comfortable home, with school instruction by applying to Miss E. E. Kenyon.

MRS. CADY'S SCHOOL FOR YOUNG LADIES. Prepares for Smith and Wellesley, and admits to Vassar by Certificate. Circulars. Early application necessary.

VERMONT, DURLINGTON. VERMONT EPISCOPAL INSTITUTE. Boarding School for Boys. Prepares for College and Business. Military drill. Terms moderate. Fifty-seventh half-year opens September 3, 1888. Send for catalogue. H. H. ROSS, A.M., Principal.

SCIENCE CLUBBING RATES.

Table with columns: 10% DISCOUNT, We will allow the above discount to any subscriber to Science or The Science Cross who will send us an order for periodicals exceeding \$10, counting each at its full price. Lists various publications and their rates.

N. D. C. HODGES, 47 Lafayette Place, New York.

C. & C. ELECTRIC MOTOR COMPANY.

Electric Motors
FOR
Arc and Incandescent Cir-
cuits, Most Economi-
cal Motor on the
Market.
Regulation Perfect.
Motors Designed for all
Power Purposes.

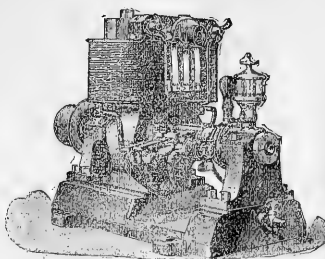

OFFICE and MANUFACTORY:
402 and 404 Greenwich Street, New
York City:
New England Office, 19 Pearl St., Boston.
Philadelphia Office, 301 Arch St.
Western Office, 139-141 Adams Street,
Chicago.
Southern Office, 25 Carondelet Street,
New Orleans.

Realizing that the circulation of SCIENCE

can be increased in no way better than by the honest recommendation and aid of its subscribers, the publisher of *SCIENCE* is prepared to extend for *six months* the term of any subscriber who will forward with the money for one year (\$3.50) the name of a new subscriber not already on the list.



PETER COOPER'S GLUE.
Prepared in liquid form by the N.Y. Liquid Glue & Adhesive Co. The long and well-known reputation of this glue for its strong adhesive properties requires no recommendation. It is the glue your furniture is glued with, and never fails to join the hardest of wood if properly applied. Always ready for use. For sale everywhere.
CONTAINS NO ACID.

Unalterable & Fragrant
GLUE PASTE
A strong and harmless preparation of flour and glue for Photographers, Manufacturers, Merchants, Insurance Companies, Banks, and family and office use. Contains no acids. Unlike Mucilage, adheres and dries immediately. N. Y. Liquid Glue and Adhesive Co., Preparers of Peter Cooper's Glue in Liquid Form, 18 N. William St., New York. *Used in this office.*



Theatres.

BROADWAY THEATRE. Corner 41st St.
MANAGER.....MR. FRANK W. SANGER.
LITTLE LORD FAUNTLEROY.
Evenings at 8. Mat. Sat. at 2.
LYCEUM THEATRE. 4th Av. and 23d St.
Daniel Frohman.....Manager.
SWEET LAVENDER.
MADISON SQUARE THEATRE.
Mr. A. M. Palmer.....Sole Manager.
CAPTAIN SWIFT.
PALMER'S THEATRE. B'way and 30th St.
M. COQUELIN AND JANE HADING.
Scale of prices, \$2, \$1.50, \$1, and 50 cents.

A Useful and Handsome Present
Prices Reduced for the Holidays.



Warranted 14 karat gold and to give perfect satisfaction—is pronounced by hundreds of pleased customers to be the best fountain pen in the market because it is always ready. Writes freely and never gets out of order.
Sent by mail prepaid for \$1.50, \$2.00 and \$2.50 each, according to size selected.

These are special prices for the holidays, and this offer should be availed of by all who write.

JOHN S. HULIN,
Mfg Stationer and Steam Printer.
Wedding Invitations and Visiting
Cards Engraved to Order.
369 BROADWAY, N. Y.
Near Franklin Street.

The Largest, Handsomest, and Most Complete Account-Book Manufactory and Printing Establishment for Fine Commercial Work in New York City.

Readers of Science

Corresponding with or visiting Advertisers will confer a great favor by mentioning the paper.



JOHN HASTINGS = -A-R-HART = JOS=TRIPP
PreSt. Gen Manager VPreSt.

**ENGRAVING FOR
ALL ILLUSTRATIVE
AND ADVERTISING
PURPOSES**

BRANCH AT 728 CHESTNUT ST.
PHILADELPHIA, PA.

67-71 PARK PLACE
NEW YORK

Arnold, Constable & Co.

WHITE GOODS.

PRINTED DIMITYS.

White and Colored Embroidered Piques,
Laces, Stripe Mulls.

FIGURED SWISS.

Broadway & 19th St.

New York.

SILKS FOR TENNIS WEAR.

The Novelty this Spring for Ladies' and Misses' Tennis Suits and for Gentlemen's Tennis Shirts is a silk fabric that can be washed without injury to fabric or color. This silk is made 24 and 32 inches wide, in plain colors, in delicate stripes and checks, \$1 and \$1.50 per yard.

For such as prefer woolen materials we also have several lines of the finest Scotch and French Flannels from 55 to 60 cents per yard.

JAMES MCGREERY & CO.

BROADWAY AND ELEVENTH ST.,

NEW YORK CITY.



GOOD NEWS TO LADIES.

Greatest inducements ever offered. Now's your time to get up orders for our celebrated **Teas and Coffees**, and secure a beautiful Gold Band or Moss Rose China Tea Set, Dinner Set, Gold Band Moss Rose Toilet Set, Watch, Brass Lamp, or Webster's Dictionary. For full particulars address **THE GREAT AMERICAN TEA CO.** P. O. Box 239. 31 and 33 Vesey St., New York.

Readers of Science

Corresponding or visiting with Advertisers, will confer a great favor by mentioning this paper.

Brokers and Auctioneers.

R. ELLIS & CO.

BUSINESS, HOTEL AND PATENT BROKERS,
AUCTIONEERS, ETC.

No. 176 BROADWAY,

Room 46.

New York

CLIENTS Advised free of charge.

J. P. TRAVER & CO.,

General Auctioneers,

Real Estate and Business Brokers,

OFFICE, 23 PARK ROW,

OPPOSITE POST OFFICE, (ROOMS 14 & 15) New York.

Mortgages Foreclosed. Cash Advanced on Consignments.
Property of Every Description Bought, Sold and Exchanged.



KIMBALL'S STRAIGHT CUT CIGARETTES.

Unsurpassed in quality.
Used by people of refined taste.
Highest award at Brussels, 1888.
The finest smoking mixtures are of our manufacture.
Fifteen First Prize Medals.
WM. S. KIMBALL & CO.
Rochester, N. Y.

A TEMPORARY BINDER
for *Science* is now ready, and will be mailed postpaid on receipt of price.

Half Morocco - 75 cents.



This binder is strong, durable and elegant, has gilt side-titles, and allows the opening of the pages perfectly flat. Any number can be taken out or replaced without disturbing the others, and the papers are not mutilated for subsequent permanent binding. Filled in this binder, *Science* is always convenient for reference.

N. D. C. HODGES,

47 Lafayette Place, N. Y.

Sprague Electric Railway and Motor Company.

For Stationary or Railway Work,
for Mining or Engineering
operations the SPRAGUE MOTORS
are unexcelled.

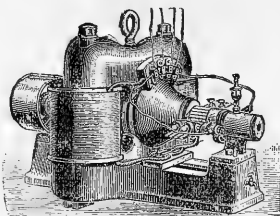

Estimates given for complete
Power Installations.

Send for Circulars and full
Information.

16 and 18 BROAD STREET, NEW YORK.

ELECTRICAL TESTING BUREAU,

Johns Hopkins University, Baltimore, Md.

Resistance Coils and Boxes Compared.
Am meters and Volt meters calibrated.
Condensers standardized.
Primary and Secondary Batteries Tested.
Efficiency of Dynamos and Motors Determined.
Insulation of Cables and Wires Tested.
Etc., Etc.
Circulars describing Methods Used, Prices, Etc., sent on Application.
Address as above.

Insurance.

DEATH IS DANGEROUS.

We call attention to the new form of Accident (indemnity) Insurance policies, which are written by the Merchant's Casualty Insurance Association, 21 Park Row, New York City, John S. Purdy, Secretary. These policies cover weekly allowances of from \$10 to \$25, according to occupation, at a cost of only \$6 a year exclusive of the cost to join, which is \$5 payable once only. The public, as a rule, carry life insurance, and the ordinary accident policies issued by companies, paying a sum in case of death, is not so desirable as one of these indemnity policies in case of accidents, which are so plentiful in this fast age with its railroad horrors, fast driving, electric wires and other countless forms of danger to which the public is constantly exposed. The fact of the Association having no unpaid claims, and its having just passed an examination by the Insurance Department of New York State, shows that the management is liberal with its policy-holders and conservative in its action. The Association also desires to secure energetic Agents in every village and town, to whom territory and favorable terms will be given.

TO EMPLOYERS.

Having purchased the fixtures, good will, &c., of the NEW YORK EMPLOYMENT BUREAU, at No. 681 BROADWAY, in this city, we request the patronage of the public in the future. We desire to fill a long-felt want for an employment bureau, where only the best grade of male help is dealt in, and it is our aim to send ONLY such help as is ordered in every instance, and our patrons can rely on us to send strictly first-class help, the references of whom we personally investigate before sending to any one. We simply request a trial, and are convinced that we will give satisfaction in every case. We have on hand help in every branch, which we can send upon receipt of telegram or letter, AND FOR WHICH WE MAKE NO CHARGE TO AN EMPLOYER.

NEW YORK EMPLOYMENT BUREAU,

(AS REORGANIZED).

SCIENCE

[Entered at the Post-Office of New York, N. Y., as Second-Class Matter.]



A WEEKLY NEWSPAPER OF ALL THE ARTS AND SCIENCES.

SEVENTH YEAR.
VOL. XIII. No. 318.

NEW YORK, MARCH 8, 1889.

SINGLE COPIES, TEN CENTS.
\$3.50 PER YEAR, IN ADVANCE.

SOME NEW ELECTRIC RAILWAYS.

We present in this issue a view taken from a photograph, last summer, of one of the electric cars on the Naumkeag Street Railway of Salem, Mass., of which Mr. Charles F. Odell is president. This electric road was equipped during the past year by the Sprague Electric Railway and Motor Company of New York, for the summer traffic between the city of Salem and a watering-place about a mile or two away, known as the Willows.

The cars ran very successfully all last summer while in use, carrying large numbers of passengers, and giving perfect satisfac-

tion to the president and directors of the road, who, it is said, intend adding more electric cars in the spring, and extending the line as far as Beverly.

The illustration which we give presents a good idea of the large number of passengers which these cars often carry on pleasant days during the summer. In spite of the heavy load, these cars move with quickness and despatch, and mount the steep grades on the line at the rate of eight or ten miles an hour. These grades, before the introduction of electric power on the road, have often compelled horses to succumb in drawing the heavily loaded cars.

The regular Sprague overhead system in use upon the road here

includes the small No. 6 wire as a working conductor, which is the only wire suspended over the centre of the track; the main current being carried at the side upon a heavy copper conductor, which is connected at intervals of every one or two hundred feet to the working conductor.

One of the most important electric railways in the country is that in operation at Cleveland, O., also on the Sprague system. We present a view on the road, showing one of the Sprague cars drawing another on Euclid Avenue. The road has been in operation now for about a month, and has carried a large number of passengers, who are delighted with the new motive power, and the

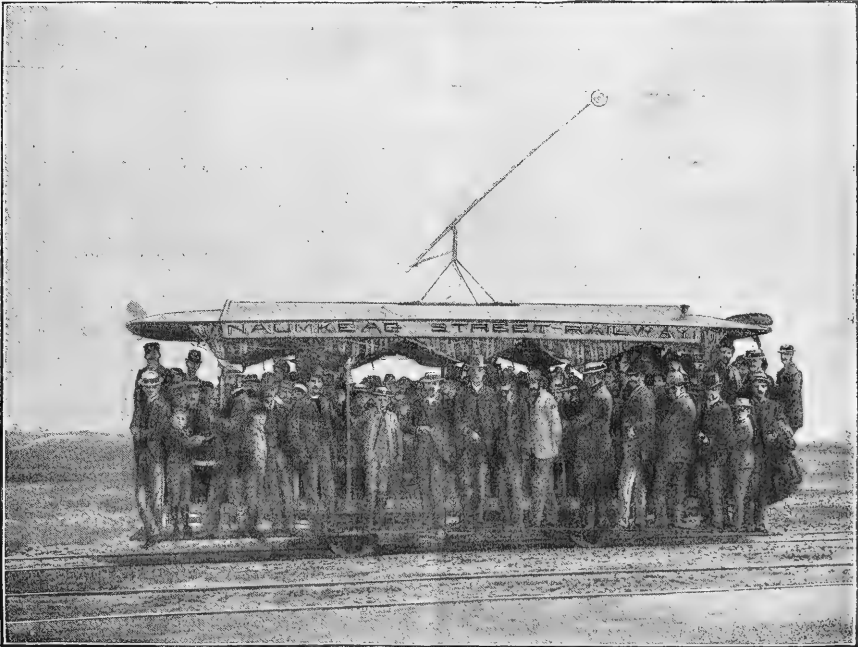

SPRAGUE ELECTRIC RAILWAY AT SALEM, MASS.

quickness with which the cars can be started and stopped, their speed, and the ease with which they mount the grades and round the curves. The lighting of the cars by electricity is another great advantage.

The equipment of this road is similar to that of the Sprague Electric Road in Boston, Mass. The poles used are of iron throughout the entire length of the line, and the overhead work is unobtrusive, making the whole line-work unobjectionable. The power-station for generating the current is one of the most complete of its kind in the country. It is fitted with Edison dynamos, Armington & Sims engines, and every thing is so arranged that its

capacity can be easily quadrupled without changing the line of machinery.

Since the road has been in operation, it has been visited by delegations from all sections of the country, of railroad men, who have inspected the operation of the road with the view of introducing the Sprague system upon their own lines. The East Cleveland Railway Company have afforded them every opportunity for inspection, and the result has been that a large number of contracts since the opening of the road have been awarded to the Sprague Company.

In a recent snow-storm which occurred in the city of Cleveland, the tracks were all covered to a depth of from six to eight inches; and the horse-railways in that city were delayed in their trips, and only ran intermittently. The electric road, on the other hand, made regular trips, ploughing its own way through the drifts, and successfully demonstrating the advantages of electrical

On account of the perfect regularity of speed which is the characteristic of these motors, on account of their differential winding, they are peculiarly adapted to the operation of printing-presses. There are also several machine-shops, carpenter-shops, and elevators which are using the Sprague motors.

HEALTH MATTERS.

Climate of Colorado.

DR. WALTER A. JAYNE presented an exceedingly interesting paper, on "The Climate of Colorado and its Effects," to the American Climatological Association at its recent meeting. In his paper he discusses the air of Colorado both as to atmospheric pressure and dryness. The annual rainfall is between fifteen and sixteen inches, — a small amount as compared with the United States in



SPRAGUE ELECTRIC RAILWAY AT CLEVELAND, O.

over animal power. The Sprague Company are now equipping snow-ploughs, to be operated by powerful electric motors, for this road; so that no snow, however deep, will be able to stop the running of the cars. It is estimated that these electric ploughs will clear the tracks quicker than an ordinary plough drawn by a dozen horses.

Among the cities which are coming into prominence in the Southern States, there is none probably in which the application of electricity for industrial purposes has received greater attention, and been more extensively applied, than in Asheville, N.C. We gave a description, in a recent issue, of the successful opening of the electric railway which connects the city of Asheville with the railroad-depot, distant about a couple of miles, which has been running successfully.

Although possessing a successful railway, the attention of the Asheville citizens in regard to electric power has not been devoted exclusively to railway-work; but there are a number of stationary motors in the city which are giving satisfaction. Both the Asheville *Citizen* and *Country Homes* are printed by electric power.

general. The winds are at times disagreeable and annoying by reason of the dust, but no injurious effects result from them except physical discomfort. In concluding his paper, he says that there are one or two very simple rules which all consumptives coming to high altitudes should understand and observe, since, because of the unusual characteristics of the climate, they are so important that neglect of them will retard recovery, and in advanced cases may destroy the slight chance still remaining to the invalid of receiving benefit from the change, and lead to a fatal result.

1. The approach to elevated regions should be gradual and by easy stages, not, in these days of Pullman coaches, to spare fatigue, but in advanced cases with limited lung space, and in those with fever and considerable activity of the disease, to avoid over-taxing the capacity of the lung to adapt itself to the rarefied atmosphere. For the same reason the invalid should, for a time after arrival, either take very moderate exercise or none at all.

2. The residence should be continuous and prolonged.

He is confident, that, were the first of these rules more generally followed, we should hear far less of the ill effects of high altitudes,

and be able to note a larger percentage of advanced cases as improved; and if the second was faithfully observed, there would be more cures and fewer relapses.

Overcoats.

The custom in this country is so prevalent of wearing heavy overcoats, whether one is outdoors or seated in overheated cars, that the remarks of the *London Lancet* on this useful garment will probably find interested readers. The teaching of modern science and of ancient custom goes to show that heat-production within the body has much to do with the tissue changes concerned in muscular activity and with healthy digestion. It is conserved by warm and moderate, wasted in evaporation by excessive, clothing. Finally, by a simple nervous re-action, it is increased after the contact of external cold.

It follows from these observations, that, if we be so clad with comfortable underclothing that surface perspiration is not formed in excess, and is rapidly removed, one great cause of chill—sudden evaporation—is done away with. Outer cold, then, provided it is not too severe, only touches, as it were, the spring of the heat-making metabolism, and, exciting an elastic rebound in the chain of vaso-motor fibres, awakens that oxidative action by which every tissue is made to yield its share of heat to the body. This bracing influence is lost wholly or partly to those who are too heavily clothed, and in its place we may have a dangerous excess of surface heat. It is for this reason that the *Lancet* has before protested, as it now does, against the indiscriminate use of the thick and heavy overcoat; and it thinks that men in fairly robust condition, especially if young, should be clad warmly next the skin, and wear either a light top coat or none at all.

There can be no doubt that the habitual use of great-coats is indirectly accountable for the chills which they are intended to prevent. Were the overcoat worn continuously, it might attain its object. Its intermittent use, even when ample underclothing is worn, affords no solid guaranty of safety, but rather the reverse. The man of sedentary habits has especial need to remember this. He emerges daily from a warm breakfast-room clothed in his ordinary winter garments, with probably woollen underwear, and over all the heavy ulster or top coat. After a short walk he finds that the sense of warmth he began with is more than maintained. He arrives at his office or place of business, and off goes the overcoat, though the air of the newly opened room is as cold as that without, and draughty in addition. During the day perhaps he travels to and from adjacent business-houses, wearing only his house clothing. The overcoat is laid aside till closing time reminds him of the journey home. The frequent result is, that somehow, between the hours of his departure and return, he is chilled. No doubt he would run as great a risk if, lightly clad, he were to face the rigor of a winter day. In this case, however, exercise and habit might do much to develop the power of endurance, and there would, at all events, be less danger of sudden cold acting upon a freely perspiring surface. Woollen underclothing represents a state of healthy comfort intermediate between these extremes, and more resistant to chill than either.

In commending its use, however, the *Lancet* does not assert that the influence of age and constitution is to be overlooked. Youth can oppose a power of resistance to depressing agencies which does not reside in the worn-out nerve-centres of a ripper age. Similarly, that elastic re-action which characterizes the nervous and sanguine types is not to be looked for in the lax tissues of the lymphatic. The weaker physique naturally calls for fuller protection than the stronger; and any rule requiring the disuse of the overcoat should allow of reasonable exceptions in favor of the old and constitutionally feeble. Unusual severity of weather, especially if associated with night air and the loss of sleep which this implies, is another condition which might well constitute an exception. In such a case we are compelled to add some form of overcoat to the ordinary amount of clothing. Some parts of the body—for example, the chest, throat, and feet—are certainly more susceptible to cold than others. As a useful safeguard, cold or tepid bathing of such parts is in merited favor. The custom so common with many persons, especially women, of walking out in thin-soled boots, often plays an important part in catching cold.

The progress of time and of rational thought may be expected to bring in a more comfortable arrangement by clothing the foot in woollen hosiery and a stouter boot.

SWINE OR MAN.—It is said that more money has been spent by the United States Government in the investigation of the diseases which affect swine than of those which affect the human species.

AIR AND WATER ANALYSES.—Modern investigators are not satisfied with chemical analyses of drinking-water and air as tests of their purity, but demand a biological test as well. Bujwid has recently been examining the air and water of the city of Warsaw by the most modern methods. He states that pathogenic micro-organisms are ordinarily found in the air: it therefore follows that disinfection of hospitals and operating-rooms is of no practical value or significance. Certain micro-organisms which may be found in the air Bujwid failed to find during investigations over a period of three years. Of those found in the air non-pathogenic, but one not yet known gives rise to suppurations in mice and rabbits; the rest are innocuous. The number of bacteria in the air is subject to great variations, and depends largely upon the winds and conditions of habitation. After a rain or snow the number is smaller. Basement rooms and abodes contain the largest numbers. On an average, one hundred thousand times more bacteria are found in water than in air. Good water should not contain more than three hundred rod bacteria to the cubic centimetre (0.06 of a cubic inch). Different results were obtained from the examinations of water from various springs and running streams. Above the city the water contained about three hundred bacteria, in the midst of the town over fifty thousand, to the cubic centimetre. Bujwid found no pathogenic micro-organisms whatever. After filtering this same water (sand-filters have recently been introduced into Warsaw), the proportion of bacteria diminished from twenty to sixty. Spring water contains a still larger number of micro-organisms. In the discussion which followed a presentation of these views by Bujwid, Barzyci stated that in a village near the city of Rzeszow, having no spring, a peasant living by the creek was affected with typhoid. His linen was washed in the stream. Shortly many of the inhabitants who obtained their drinking-water from the creek, and who lived below the house in question, likewise sickened with typhoid: all living above escaped.

BALDNESS.—As our readers are already aware from the discussions which have already appeared in *Science*, various theories have been proposed to account for the baldness which prevails to such an extent in civilized countries. A Swiss writer attributes it to a microscopic fungus, which, however, he has not as yet been able to describe or indeed to discover. He thinks that barbers should be compelled to disinfect their combs and brushes.

BOSTON MILK-SUPPLY.—In no city of the United States is the food-supply more carefully watched than in Boston. The inspector of milk of that city has just made his thirtieth annual report, which covers the work performed by him during the year 1888. From this report it appears that 915,867 more gallons of milk were sold in 1888 than in 1887, and, notwithstanding this increase, the quality was much better. In 1883, 60 per cent of the milk examined was found to be below the standard fixed by law. In 1884, only 40 per cent was below; in 1885, 30 per cent; in 1886, 18 per cent; in 1887, 12 per cent; and in 1888, but 8 per cent. The inspector justly claims this great improvement as the result of the labors of his department.

THE MICROBE OF MALARIA.—The evidence is accumulating that the microbe of malaria which was described by Laveran is the cause of intermittent fever. At a recent meeting of the French Academy of Sciences, Professor Bouchard expressed the opinion that Laveran's claim had been substantiated.

BOOKS FROM CIRCULATING LIBRARIES.—Subscribers of public libraries have of late been warned against the danger of contracting contagious diseases from books which have been in houses where these diseases existed at the time. The health authorities of Dresden have been examining the dust which had accumulated on unused volumes, with reference to the discovery of

micro-organisms, and especially the bacillus of tuberculosis. They report that they have found nothing of a harmful character, and have arrived at the conclusion that the danger of spreading infection by means of circulating libraries is very slight. They recommend, however, that books should be well dusted before being read, and that the fingers should not be wet in the mouth in order to turn the leaves. If the experiment is correctly reported, the authorities of Dresden are not justified in deducing any such inferences. The material which may accumulate in the form of dust on "unused books," and that which may collect on books in infected rooms, are of a totally different character. To determine the danger from the use of these latter books, another series of experiments must be made, and, in the present state of our knowledge as to the germs of infectious diseases, not much could be expected even from such experiments. The germs of measles, scarlet-fever, and small-pox, which diseases are known to be propagated by articles of wearing-apparel which have been exposed in infected rooms, have never been recognized, and the search for them in the dust which has collected on books would doubtless be as futile as it has been elsewhere; but there is no *a priori* reason why such books might not be carriers of contagion equally with clothing and furniture. The advice given to dust books well before reading them, in order to avoid danger, is, if the Dresden authorities are correct in saying that such dust is harmless, entirely unnecessary, while, if the dust should be infected, it would be the best possible way to spread the infection. Books which have been in an infected room, especially if they have been opened, should be destroyed. It is practically impossible to disinfect them.

THE LOCO-WEED.—Readers of *Science* have from time to time written us regarding the "loco-weed" and its poisonous properties, and we have recorded every thing which could be learned about its effects on animals and men. In Vol. IX. p. 32, we referred to a curious affection which exists among horses in north-western Texas, known as "grass-staggers," which is caused by eating the "loco-weed," which gives rise to the saying that the horses are "locoed." The Indians believe that an insect is the cause of the disease, but competent investigators have failed to find any insect life upon the plant. In Idaho the same disease is found, and is treated by amputation of the tails of the affected animals (*Science*, ix. p. 306). Francis H. Snow of Lawrence, Kan. (*Science*, ix. p. 92), refers to observations which tend to support the idea that insects are connected with the causation of the disease. Professor Sayre of the University of Kansas was said to be making an exhaustive study of the "loco" problem. Dr. Mary Gage Day of Wichita, Kan., has recently made a number of experiments upon healthy cats to test the toxic qualities of the weed, and has communicated the results to the *New York Medical Journal*. The "loco-weed" is a popular name given to *Astragalus mollissimus* and *Oxytropis Lambertii*. In the experiments of Dr. Day, a decoction of the roots, leaves, and stems of plants gathered in September was used. The result of feeding the decoction to a kitten was to produce diarrhoea, vomiting, convulsions, paralysis, and, at the end of twenty days, death. After death, ulcers were found in the stomach and intestine. In another experiment with a more concentrated decoction, on a full-grown cat, the symptoms were much the same, the cat dying on the thirteenth day. Professor Vaughan of the University of Michigan made experiments on frogs and kittens, injecting the decoction under the skin, producing death. With reference to the character of the plants at different seasons of the year, Dr. Day is convinced, by numerous experiments on material gathered in different months, that the greatest amount of poison is present in the autumn and winter, after the seeds have ripened, and that the explanation of the ranchmen, that the "loco" disease is more prevalent in the autumn and winter because the animals eat more of the weed from the scarcity of other food, is only a partial explanation. The greater toxicity of the plants at that season she believes to be a very important element. From the facts and experiments detailed, the following conclusions are drawn: 1. There is some poison in "loco-weed" which may cause the illness, and, if sufficient quantity is taken, the death, of an animal. 2. This poison is contained in the decoction obtained from the plants, and, by systematically feeding it to healthy cats,

cases of "loco" disease may be produced. 3. From the large quantity of the plant or the decoction required to produce the disease, the poison must be weak, or, if strong, it must be in very small amount.

SCIENTIFIC NEWS IN WASHINGTON.

Effect of Permanent Moisture on Certain Forest-Trees.¹

In 1874, while engaged in the work of the Kentucky Geological Survey in the lowland district near the Mississippi, I had an opportunity of making some inquiries concerning the knees of the swamp cypress, which led me to the supposition that these peculiar processes from the roots served in some manner to aerate the sap. Their functional importance was indicated by the fact that whenever their summits were covered by water, as by the sinking of the ground on which they stood in the earthquake of 1811, or by the artificial elevation of the water during the summer season in mill-ponds, the trees to which they belonged inevitably died. On the other hand, the trees which grew upon high ground failed to develop any knee processes beyond slight tuberosities on the upper side of their main roots. The results of this and other inquiries were put in press about twelve years ago, but were first published in Vol. XVI. No. 1, of the "Memoirs of the Museum of Comparative Zoölogy at Harvard College," June, 1887. An incidental reference to the fact was made in the third volume of the reports of progress of the Kentucky Geological Survey (1877), p. 74.

Since that time I have incidentally observed certain other phenomena connected with the conditions of our forest-trees in swamps, which, so far as my knowledge goes, have not received adequate attention. I have hoped to find an opportunity to make a more careful inquiry into the subject, but this does not seem possible. I therefore venture to give the results of the very incomplete investigation in this letter.

As it seemed unlikely that the cypress should be the only tree to develop root processes intended to fit the plant for semi-aquatic life, I searched for similar excrescences on the roots of our other forest-trees which find their station in wet lands. Until within a few months, I have been unable to find any other species in which the processes were sufficiently developed to be classed in importance with the cypress knees. (A very little inquiry showed me that all trees which find a station in very wet lands have their large roots nearer the surface of the soil than in the upland districts, and several species exhibit a tendency to have their roots at certain, points actually on or above the soil.) Observations in the Mississippi swamps seem to show that our ordinary tupelo or sour gum (*Nyssa uniflora*, Walt.) exhibited rather more of this tendency than any other species, and I suspected that under favorable circumstances it might show a peculiar adaptation to its swampy surroundings. Observations in the Mississippi valley were difficult, for the reason that the pools beneath which the roots of the trees extend dry out during the summer droughts. Recently, however, in the Dismal Swamp district of Virginia and North Carolina, I found many areas occupied by the tupelo which did not become desiccated in the dry seasons. In all such positions, the tree, when of mature growth, has a peculiar feature in its roots which serves in an admirable way to accomplish the results attained by the cypress knees, though the method by which it is attained is peculiar. In place of forming a spur-like process upon the root, the root itself arches upward in such a manner that the upper part of the bow rises above the level of the water in the growing season. Where the depth of water is slight, the arch may be indistinctly developed. Where the water stands a foot or more in depth, the arch becomes very much elevated. I found specimens in which the roots assumed a horseshoe-like curve, rising to the altitude of three feet above the soil, the distance apart of the roots at their base not exceeding a foot. These roots commonly have a diameter of from three to six inches. The fact that they rise above the level of the water in the growing season is often attested by a considerable growth of annual plants which have become planted in the crevices of the bark.

These roots of the *Nyssa* do not appear to develop their arches until the tree attains a considerable size. I found no trace of them

¹ Preliminary notice of some results of the United States Geological Survey examination of swamp-lands, by N. S. Shaler.

in the cases where the plant was less than one foot in diameter at the ground, and they do not become a conspicuous feature until the tree is nearly adult; i. e., until it has attained a diameter of eighteen inches or more. At this stage of growth, if the crown be permanently wet, the knees become an extremely conspicuous feature, fifteen or twenty often being found grouped about a single stem at the distance of from five to twenty feet from the base of the bole. It thus appears tolerably certain that the need of having a portion of the roots above the water-level will be found in certain other trees. Thus far my note-books supply me, however, no certain indications of this fact. Indeed, it is only in the case of *Taxodium* and the tupelo that I have found the plants under circumstances which would show clearly their needs in this respect.

There is another feature concerning the growth of water-loving trees, or at least those which are tolerant of permanent moisture, that deserves attention. I have reference to the form of the bole or trunk as it is exhibited in the specimens of the Southern species, which occupy situations diversely affected by moisture. On very wet ground the trunk appears to be generally expanded at the crown, in a measure, which is not the case in specimens of the same species growing in dryer situations. Thus, in the cypress, we not infrequently find the bole at the crown, and for some feet above, having a diameter twice as great as it is at ten feet above the surface. Where, however, the tree grows on a dryer soil, the expansion at the base is much less considerable. The same appears to be the case in the tupelo, which often has a remarkable expansion of the trunk near the surface of the ground, where the plant occupies very wet situations. In a somewhat less degree, this feature appears to exist in all our trees, except the willows, which occupy sites characterized by diversity in the measure of wetness. I should state that this opinion rests entirely on eye-measurements. I have long intended to submit the impression to the criticism of a careful determination, but have not been enabled to do so. The impression has, however, been so often repeated to me in different regions, that I am inclined to believe there is little chance of error in the statement. I trust that some one who is well placed for such observations will subject the suggestion to a careful statistical inquiry.

If I be correct in the opinion that trees in very wet situations develop an enlarged bole near the surface of the ground more frequently than those which occupy dryer situations, we may perhaps account for the fact in the same way in which I am disposed to explain the occurrence of knees in *Taxodium* and of root-loops in the tupelo; viz., through a need of an aeration of the sap, which is denied in roots that are under water.

It appears to me from eye-observation, as yet uncorrected by measurements, that the buttresses which the water-loving trees form about the trunk are more considerable than they are in the same species on higher land. If this be really the case, it may perhaps be due to the same physiological need which has led to the formation of knees, and to the enlargement of the bole near the crown of the tree. I feel less confident as to this increase in the buttress prominences than I do concerning another observation which I have above set forth. I state the impression for the reason that it has very frequently been borne in upon me in my studies on the development of swamp-plants. At first I was disposed to attribute the peculiarity to the fact that the roots of swamp-trees do not usually extend far beneath the surface, and therefore the buttresses were enlarged in order to give greater stability to the trunk. This hypothesis was disproved by the fact that trees growing in such situations are very rarely uprooted by storms. I failed, indeed, to find a single case of such uprooting by the action of the wind in several thousand miles of journeys through the morasses in the eastern part of the United States. The only cases in which such overturning met my eye appeared in the swamps near the Mississippi, which, on the whole, exhibit buttress structures much less conspicuously than the trees of the Atlantic coast morasses.

There is another interesting series of facts connected with the effect of excessive water on our forest-trees which are tolerant of swamp conditions. These relate to the variations in the character of the bark, the mode of branching, etc., of the plants in situations diversely conditioned as regards the amount of moisture. In almost all our forest-trees, which range from dry to very wet stations,

there are noticeable diversities as regards the above-mentioned features, according to the station they occupy. Thus the ordinary chestnut oak varies in a very noticeable manner between dry ground and wet. The tree in very wet situations has a much smoother bark than it exhibits on high land, and I am told by the woodmen that this bark in trees which grow within the swamp is unfit for the purposes of tanning. The variety of tupelo known to the woodman of the Dismal Swamp as the "pawpaw gum," appears to owe its peculiarities to the fact that it normally grows in much wetter localities than the ordinary *Nyssa*. It differs from the parent species in that the bole is singularly enlarged near the crown, often having a diameter for some feet above the surface of the water two and one half times as great as it has at the height of ten feet above the ground. In this connection it may be noted that this variety of the tupelo is less disposed to develop the root-loops than the more common form, it appearing indeed as if the great extension of the bole near the crown made the development of these processes unnecessary.

The variation in the character of our forest-trees when exposed to swamp conditions affords an extremely interesting field for an important class of inquiries concerning the influence of environment, and the effect of natural selection, on the development of organic forms. In the Dismal Swamp, where the water-level during the growing season is subject to relatively little variation, a difference in altitude of six inches, or at most a foot, will greatly affect the character of the timber-trees and other plants. With each such variation in height, we perceive a noteworthy change in the character of the vegetation.

MENTAL SCIENCE.

Statistics of Visual Images.

THE American Society for Psychical Research has devoted considerable time to the study of unconscious mental habits, a field that abounds in suggestions applicable to the class of phenomena which such a society investigates, but is still more valuable as contributing to our knowledge of obscure mental traits. Thus Professor C. S. Minot has shown that we are by no means as likely to think of one number as of any other, when simply asked to think of a number, but that there exist certain definite and very general preferences for certain numbers above others. People have "number-habits," or unconscious tendencies to choose a certain few numbers (perhaps on account of greater familiarity, easy manipulation, peculiar association, brevity of utterance, or other causes) when an unlimited choice is offered them. In No. 4 of the "Proceedings of the American Society for Psychical Research," Professor Minot brings together extremely interesting material for a similar study with reference to the "diagram-habit." The committee on experimental psychology of this society sent out a large number of postal-cards bearing the printed request, "Please draw ten diagrams on this card, without receiving any suggestion from any other person, and add your name and address." Five hundred and one such cards have been collected, of which 310 were drawn by men, 169 by women, and 22 had no name.

The first point of interest in such a study is to observe how various the drawings of five hundred persons will be. We are not told how many different designs occurred; but the occurrences of 83 different designs have been tabulated, and their sum includes about half of all the drawings. But the real poverty of the intellect when it expresses itself naturally is made evident by the great preponderance of a very few simple diagrams. Thus circles were drawn 209 times; squares, 174 times; equilateral triangles, 160 times; crosses, 160 times; letters of the alphabet, 82 times; diamonds, 80 times; oblongs (horizontal), 78 times; inscribed circles, 78 times; stars, 77 times; faces (profile to the left), 61 times; houses, 56 times; rhombi, 56 times; scrawls, 53 times; other animals and heads, 48 times; flowers, 46 times; leaves, 45 times; hexagons, 42 times; cubes, 42 times; right-angled triangles, 42 times; figures of men, 32 times; and so on. The above are the twenty most frequent drawings, and, it will be seen, form an aggregate amounting to nearly one-third of all the drawings. On the average, each occurs 80 times. If we group to-

gether the designs belonging to the same natural class, we find, of circles, both plain and with inscribed figures, 287; of squares, both plain and with inscribed figures, 236; of triangles, equilateral and otherwise, 220; of four-sided figures, 245; the sum of which four classes is 988, or nearly one-fifth of all the drawings. In other words, if a person is about to draw the first ten designs that come to his mind, it is a pretty safe prediction that two of the ten will be either a circle, a square, a triangle, or a quadrilateral.

Tabulation upon another basis reveals the fact that 2,344 diagrams were drawn exclusively with straight lines, and 1,337 diagrams with less than six straight lines; that 681 diagrams were drawn exclusively with simple curved lines, and 603 diagrams with less than six such lines. One is more than three times as apt to draw a diagram composed of straight lines than one composed of curved lines. Among the non-geometrical designs, animals, plants, and manufactured objects include by far the most frequent drawings. Men are drawn 32 times; hands, 10 times; flowers, 46 times; leaves, 45 times; and trees follow with only 14 times; houses are drawn 56 times; and the next figure under this class is 15 for books.

Furthermore, without any express implication in the request, the respondents have taken it for granted that ten different designs were wanted, and very few repetitions of designs occur. If the number of persons drawing each kind of design be tabulated, it reinforces the conclusion suggested by the original tabulation as to the limitations of the mind when acting as it does in these tests. 40 per cent of the respondents have drawn circles; 34 per cent, squares; 31 per cent, equilateral triangles; 25 per cent, crosses; 16 per cent, diamonds, etc.; and there are very few designs drawn by only one person.

What this research especially impresses is the lack of individuality in our off-hand mental products. As Dr. Minot well puts it, "We too easily forget our similarity, and forget that it stretches over trifling habits as well as over the great and little modes of thought. We feel, and for the most part willingly acknowledge, the likeness of our natures, but our sentiments and ideas we are over-inclined to consider original. Such tests as the drawing of the diagrams thrust home the conviction that even in trifles we differ very little. The images and notions which pass across the consciousness of each individual are almost all common property: they are comparable to coins,—every one is a separate entity, but yet the stamp is the same. Our thoughts are in a large measure owned by the community: we are in mental matters all pure communists."

There are other questions upon which these results shed interesting light. The first is the order in which one is apt to draw, and by inference to think of, the several designs. One would suppose that the designs occurring most frequently would also be the ones first thought of. The results, however, do not reveal as close an agreement as one would expect. They show that an equilateral triangle is more apt to be found among the first diagrams than any other figure. Then come squares, then right-angled triangles, then circles, then faces not in profile, then faces with profile to the right, then diamonds, then oblongs, and so on. It is possible that the order of frequency of diagrams occurring the very first of the ten would be more in agreement with the order of general frequency. Another interesting comparison is between the designs furnished by the men and by the women. Remembering that we have nearly twice as many records of the former as of the latter, we find that men have more than their share of circles, both plain and inscribed, of rhombi, of scrawls, of men, and of right-angled triangles, while women are fonder of squares, equilateral triangles, letters, diamonds, stars, faces, flowers, and so on. "That gentlemen preponderate with hearts, and ladies with hands, perhaps may seem to many a natural consequence of our social conditions;" and other of the preferences seem to have a natural basis. That many of them must be regarded as accidental is doubtless to be admitted. The general law, however, is that there is much more repetition, and thus much less variety, among women than among men.

A few residual points should be noted. Some of these designs are undoubtedly to be traced to the existence of a "form" in the mind towards which a person may persistently tend. The "num-

ber forms" so vividly described by Mr. Francis Galton may serve as a type of such habits. When toying with a pencil in one's hand, many persons will find themselves drawing over and over again a simple figure. This accounts for some of the very peculiar drawings furnished by some of the respondents, and testimony in favor of such "forms" could easily be gathered. The individual bent, the dominant interest, the "apperception," as the psychologist would term it, serves as another clew. "A painter recalls his palette; a naturalist, his butterfly; a physician, his skull; a college student, his bicycle; in a few cases the entire ten drawings seem to be taken from "professional" suggestions. Another class of drawings seem to have their origin in the surrounding objects, being really copies of objects seen at the time; but this is a small class, and most of the images are doubtless drawn from the resources of past experience. Finally, the drawings are almost all simple in character. We draw what is easiest. This is well shown in the prevalence of faces seen in profile to the left, of left-handed spirals, and so on: for these are easier to draw, and the corresponding designs inverted towards the right; that is, easier for right-handed persons. So that these predominances indicate at once the general right-handedness of mankind, and the tendency to draw what is easiest.

The practical application of these facts tells severely against the arguments supported by the English Society for Psychological Research in favor of thought-transference. Dr. Minot points out that in several series of experiments reported in their "Proceedings" the position has been assumed that one kind of card, of number, of simple figure, is as likely to be thought of as another, and has estimated the improbability of the recorded coincidences accordingly. All evidence in which such an assumption is used must be looked upon with suspicion; and only when the conditions of the experiments take full and complete account of this very universal tendency for minds to run in similar grooves when dealing with simple things, will it be time to consider the evidence in favor of any abnormal form of the communication of ideas.

COMMERCIAL GEOGRAPHY.

An Agricultural Map of North America.¹

THE climatic conditions of North America are favorable to agriculture, except in the arid regions and in the extreme north. By the uncultivable region the agricultural land is divided into two parts of unequal extent,—the narrow Pacific coast strip, and the Atlantic region. East of the Rocky Mountains three zones of agriculture may be distinguished. The most southern one is that of subtropical cultures, reaching to the 37th degree of latitude; the central one is that of the culture of corn; and in the most northern zone wheat and oats are the principal products. On the Pacific coast there is no zone of subtropical cultures, but two zones only can be distinguished,—that of wheat, and that of oats. This fact shows that there is a marked difference between the Pacific and Atlantic regions. Two-thirds of the latter are used for the culture of subtropical plants, to which class corn belongs, while these are nowhere cultivated on the Pacific slope. This contrast is caused by the difference of climate, that of the wheat districts of California and Oregon being characterized by a uniform oceanic climate, with prevailing precipitations in winter, and dry summers; while the cotton and corn regions of the Atlantic side have a continental climate, with abundant precipitation during the warm seasons. Only the oats regions on the Pacific and Atlantic sides are analogous, the climate being characterized by a low temperature of summer and sufficient precipitation.

While the dampness and heat of the Atlantic summer favor the cultivation of subtropical plants more than in any other country, the sharp contrasts of summer and winter prevent the successful cultivation of plants of the southern temperate zones, especially that of the vine, oranges, and lemons, which require a spring with slowly rising temperature and moderate precipitation.

On the accompanying map the extent of each culture has been laid down according to the results of the tenth census, the percentage of area of land-occupied by each culture being inserted in a large-scale map, of which the present sketch-map is a reduction.

¹ According to Max Sering, *Die landwirthschaftliche Konkurrenz Nordamerikas*.

The area of cotton-culture has attained its present limits only after many attempts to introduce it still farther north, where early frosts prevent its being successfully carried on. At present the northern limit of cotton-culture approximately coincides with a mean January temperature of from 36° to 39° F. Even in the southern districts of cotton-cultivation, it is greatly influenced by the excessiveness of climate. While in the south of Spain the cotton-plant is a perennial, it is killed in the United States every winter by frost, and the plantations have to be renewed year by year. But the American plant exceeds, in amount and quality of its product, that of countries where the climate is more favorable to its growth. Besides cotton, corn is grown to a considerable ex-

We turn to considering the second zone of the Atlantic region, that of corn. In North America corn-culture extends farther north than in any other part of the earth. In more than two-thirds of the eastern part of the United States it is the principal cereal product. Its growth is favored by the heat and the suddenness of precipitation in summer, the sky being generally clear, while rain comes down during brief thunder-storms. The northern and western limit of corn-culture is not determined by the decrease of summer temperature and of precipitation, but by the increasing frequency of early frosts in the fall, and late frosts in the spring. In the valley of the Mississippi, corn ceases to be the most important culture under the 43¹/₂ degree of latitude, where the mean tem-

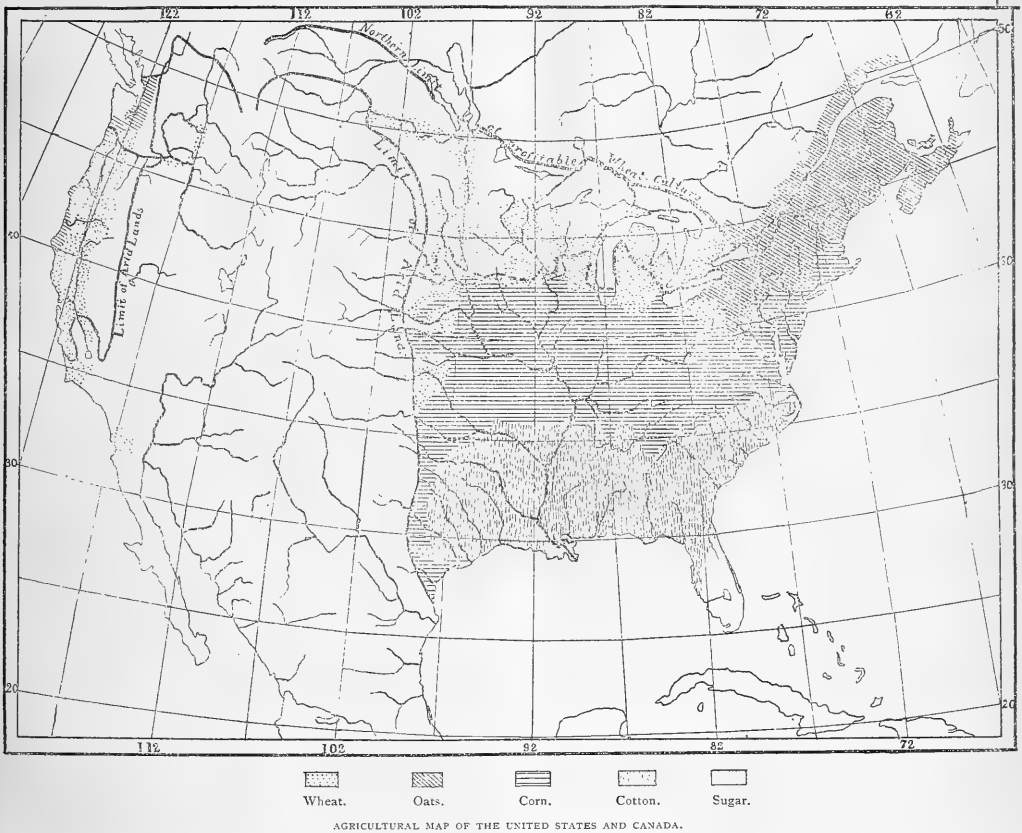

tent; but everywhere the former is the central point of interest to the farmer, more money and labor being invested in cotton-plantations than in any other culture. It is a remarkable fact, that corn, although the climate is well adapted to its growth, does not give nearly as good and rich harvests as farther north, where the climate is not so well adapted to its growth. The same is true regarding wheat, which gives the greatest and best returns near the northern limit of its possible cultivation. In the cotton region, wheat, barley, and rye are cultivated only in dry districts, in the higher parts of the Alleghanies, and in the semi-arid region of western Texas.

Sugar-cane is not cultivated very extensively, as the cold of winter hurts the young plants. It is only in the delta of the Mississippi that it is the prevailing culture, and in the adjoining parts of Louisiana it reaches a considerable extent.

perature of July amounts to 72°.5 F. In eastern Ohio and Pennsylvania it hardly reaches the 40th degree of latitude, and in the mountains of Virginia it does not extend beyond the 37th degree of latitude; while on the coast, where there are no late frosts, it rises to the 44th degree of latitude. North of this line, early varieties of corn are still cultivated, their northern limit being indicated on our map by a broken line. North of this line oats take the place of corn. In the West the corn region does not extend nearly as far north as in the East, on account of the greater frequency of late frosts, which the young plant is unable to withstand. The irregularity of the western limit is not caused by climatic differences, but by the recent settlement of the districts.

In this region wheat is cultivated extensively, but it is everywhere second in importance to corn. In the humid, warm regions of Delaware, in Tennessee, Kentucky, Missouri, Illinois, about three-

fifths of the whole region is used for corn-culture, while the northern and western limit covers those districts in which not more than one-half of the improved lands is used for this cereal. On the whole, the climate of the corn zone is not favorable to wheat, as the summers are too hot, and have too much rain. Notwithstanding this fact, the great centre of American wheat-production is situated in this region, south of the Great Lakes. It is remarkable, that, notwithstanding the great total amount of precipitation, excessive dryness in any part of the period of growth of the plant causes poor crops, long periods of clear weather being interrupted by sudden violent showers of rain. Besides this, the rapid increase of temperature in spring is not favorable to the development of wheat.

The northern zone is divided into two sections,—that of wheat, and that of oats. An important line in this region is the southern limit of summer wheat, as those countries in which only summer wheat can be grown have serious disadvantages as compared to others. As all the sowing has to be done in spring, the amount of work at this season is so great as to make the introduction of the most profitable methods of culture impossible. Owing to the severity of our winters, this line runs far more southerly than in Europe. Starting from Boston, it crosses Massachusetts, northern New York, and Ontario. It reaches the 45th parallel in Michigan, and in the prairie region descends to 38° and 39° north latitude. North of this line, only summer wheat can be grown. This region includes almost the whole arable prairie region, and the whole Dominion of Canada with the sole exception of southern Ontario. In the eastern portion this line coincides with a temperature in January of 18° F., while in the western part of the country it coincides with that of 30° F. This difference is principally founded on the difference of snowfall in those regions. While the Eastern States are covered with deep snow, the prairies have no such protection, and the dry, cold winds of winter kill the young plants.

One of the most remarkable features of the wheat area is its great extent northward in the central parts of our continent, where a clear summer favors its cultivation. The same climatic peculiarity accounts for the existence of the Genesee wheat region of central New York. Wherever the amount of precipitation in summer exceeds 50 centimetres, oats are cultivated in preference to wheat.

Finally we have to consider the Pacific coast strip. In the large valleys of California and Oregon the summers are warm, but not moist enough for the extensive cultivation of corn and cotton; while farther north the precipitation is sufficient, but the temperature too low. It is true that in a few districts of California, and also in Oregon and Washington Territory, corn is the third in importance among the cereal products; but, taken as a whole, only three per cent of the total area is applied to its cultivation. In southern California excellent crops of corn are obtained by means of irrigation.

In California and Oregon, and in that part of Washington Territory situated east of the Cascade Range, the culture of wheat is by far the most important. In California and Oregon seventy per cent of the cultivated area is used for growing wheat, a figure which is equalled only in Minnesota. The clear and dry summer favors wheat more than any other plant, a sufficient amount of humidity being retained in the ground after heavy winter rains. In southern California the cultivation of wheat requires irrigation. Second in importance is barley, which in California occupies twenty-three per cent of the cultivated area; farther north the rainfall increases, and oats take the place of barley; and still farther north barley-culture is more important than even that of wheat.

Taken as a whole, about one-half of the continent of North America is arable land, about thirty per cent belonging to the polar regions, while twenty per cent is arid land, or mountainous, rocky regions. The agricultural region includes one of the countries best adapted to the production of cotton and corn, while the climate of the same region excludes other cereals and the vine. The development of the wheat region, although very rapid, is hampered by numerous disadvantages,—severe winters, rapid increase of temperature in spring, sudden variations of temperature, late frosts in spring and early frosts in the fall, and frequent draughts impair its value, while the dryness of the early fall favors the culture. On the whole, the climate is not as favorable to the growth of wheat as that of Europe. If, notwithstanding this fact, the wheat-pro-

duction of the North-west has reached the enormous importance it has actually attained, the reason must be looked for in economic more than in agricultural considerations. The rapid colonization of the prairie regions, their easy cultivation, and the great natural highways of our continent, have given it the importance it possesses at present. But it would be erroneous to believe that this development will continue, that the amount of wheat produced and exported will indefinitely increase. When the tillable land has been taken up, and no new areas of productive land are added to the old ones, the economic reasons which have made the North-west the great granary of the world will cease, and the development will take another course, yielding greater returns from the same area than are possibly attained by the present wheat-culture.

NOTES AND NEWS.

THE director of the United States Mint, in his annual report to Congress, says that the gold product of this country for the year 1888, was 1,644,927 ounces, of the value of \$33,175,000. This is about the same as in 1887, being an excess of only \$175,000. The silver product was 45,783,632 fine ounces, of the commercial value of about \$43,000,000, and of the coining value of \$59,195,000. This is an increase of 4,515,327 fine ounces over the product of 1887. In addition to the product of our own mines, some 10,000,000 ounces of silver were extracted in the United States from foreign ores and bullion, principally Mexican. The coining of the mints during the year was as follows: gold, \$31,380,808; silver dollars, \$31,990,833; subsidiary silver, \$1,034,773; minor, \$912,201; total, \$65,318,615. The import of gold bullion and coin was \$11,031,941, and the export \$34,619,667, a loss by export of \$23,587,726. The import of silver was \$21,592,062, and the export \$29,895,222, a loss by export of \$8,303,160. The metallic stock of the United States Jan. 1, 1889, including bullion in the mints awaiting coinage, is estimated to have been, gold, \$705,061,975; silver, \$403,516,756; total, \$1,108,578,731.

—Dr. Chaillé, the well-known statistician, states that the average life of woman is longer than that of man, and in most parts of the United States woman's expectation of life is greater.

—A correspondent of the *New Orleans Medical and Surgical Reporter* says that petroleum-oil is almost universally used by the artisan and poorer classes in London as an illuminant, and the number of accidents which occur yearly with these lamps is very large. Mr. R. W. Brownhill has invented an ingenious prepayment gas-meter, based on the principle of the cigar, coffee, and other automatic supply-stands to be seen in every railway-station in London. It consists of a small attachment, which can be applied to any meter, and which will cause the gas to be delivered in definite quantities as paid for by pence dropped into a box. All that has to be done is to drop in a penny and pull a small handle, when sufficient gas for the supply of an ordinary burner for six hours will be delivered from the meter. Any number of pennies may be placed in the box, one at a time, up to 143, the handle being pulled after each penny, which would insure 858 hours' gas to one burner, or a shorter supply to several.

—Carl Zeiss, whose fame as a manufacturer of microscopes and microscopical lenses is world-wide, has just died at Jena, at the age of seventy-three.

—A flume fifty miles in length has just been completed at San Diego, Cal. It is intended for irrigation purposes and water-supply. The reservoir in the mountains, whence the water is supplied, is 4,500 feet above sea-level.

—Dr. O. J. Broch, at one time professor of mathematics at Christiania, and later minister of the Board of Trade in Norway, who more recently acted as director of the International Bureau of Weights and Measures at Paris, died at Sèvres, Feb. 5, at the age of seventy-one. It has been the especial duty of the Bureau, over which Dr. Broch presided from its creation after the Metric Convention of 1875, to construct new standards of the metre and kilogram for the different countries which were parties to that convention. At the time of his death all these standards had been constructed, and were only awaiting final approval at Sèvres before their delivery this year to the several contracting States.

— Agassiz Association, Chapter 949, New York City (Z), held its third annual exhibition of natural history collections, microscopes, electrical apparatus, etc., on Saturday, March 2, 1889, at 49 West 20th Street, near Sixth Avenue, from 3 to 6 P.M., and from 7 to 10 P.M.

— The ship-canal which is to connect Manchester, England, with Liverpool, is being rapidly constructed, ten thousand men and a great number of steam excavators being engaged upon it. The canal will be thirty-five miles long, twenty-six feet deep, and a hundred and twenty feet wide at the bottom.

— Rev. Arthur C. Wagborne, New Harbor, Newfoundland, has published "A Summary Account of the Wild Berries and other Edible Fruits of Newfoundland and Labrador."

— The exercises of the centennial celebration of Georgetown University, Washington, D.C., closed, Feb. 22, with a session in Gaston Hall, at which the honorary degrees were conferred by President Cleveland. Three gold medals were struck in honor of the occasion, which were awarded as follows: one to John Gilmory Shea, LL.D., the historian of the Catholic Church in America, for his work, "The Life and Times of Archbishop Carroll;" a gold medal, struck by the Alumni Association, presented to his Eminence James Cardinal Gibbons, for the archi-episcopal see of Baltimore; and a gold medal, like the preceding, to the President, Grover Cleveland, for the Government of the United States.

— A meeting was held, Jan. 31, in the meeting-room of the Royal Society, London, the Right Hon. Lord Rayleigh, Sec.R.S., in the chair, for the purpose of promoting a project, set afoot by some of the leading men in Munich, of erecting in that city a statue of George Simon Ohm, — a man who, although he discovered no new phenomena of very striking importance, yet by the accuracy of his thought, and the clearness of his insight into the true bearings of physical facts, was able to lay one of the principal and firmest parts of the foundation of modern physics. The occasion for the proposal at this particular time is the near approach of the hundredth anniversary of Ohm's birth, on March 16, 1789.

— The fourteenth annual commencement of the American Veterinary College was held at Chickering Hall, New York, Monday evening, March 4.

— At the meeting of the Royal Meteorological Society, Feb. 20, a report on the helm-wind inquiry was made by Mr. W. Marriott, F.R. Met. Soc. The helm wind is peculiar to the Cross Fell range of mountains in Cumberland, which runs from north-north-west to south-south-east. This range is high and continuous, and is not cut through by any valley. Cross Fell is 2,900 feet above sea-level. From the top of the mountains to the plain on the west, there is an abrupt fall of from 1,000 to 1,500 feet in about a mile and a half. At times, when the wind is from some easterly point, the helm forms over this district, the chief features of the phenomenon being the following: a heavy bank of cloud rests along the Cross Fell range, at times reaching some distance down the western slopes, and at others hovering just above the summit, while at a distance of two or three miles from the foot of the fell a slender roll of dark cloud appears in mid-air, and parallel with the helm cloud; this is the helm bar. The space between the helm cloud and the bar is usually quite clear, while to the westward the sky is at times completely covered with cloud. The bar does not appear to extend farther west than about the river Eden. A cold wind rushes down the sides of the fell, and blows violently till it reaches a spot nearly underneath the helm bar, when it suddenly ceases. The observations that have been made in the district during the past three or four years show that the helm wind is not such a rare occurrence as it was popularly supposed to be, the bar having been observed on 41 occasions in 1885, 60 in 1886, and 19 in 1887. The phenomenon takes place usually when the sky to the eastward is covered with cloud.

— Two large hydraulic canal-lifts have been recently erected at Fontinettes, on the Neufossé Canal, in France, and at La Louvière, on the new Central Canal, in Belgium. They both consist of two counterbalancing troughs, resting on central hydraulic rams, 6 feet 6½ inches in diameter, and moved by an excess of water introduced into the upper trough, and by hydraulic machinery supply-

ing water to the presses under the rams to aid the ascent. The troughs at Fontinettes are each 129 feet 7 inches long, 18 feet 4½ inches broad, and contain 6 feet 6½ inches depth of water, so as to be available for vessels of 250 tons. The troughs at La Louvière are 141 feet long, 19 feet wide, and hold water to a depth of 10½ feet, being designed to admit vessels of 400 tons. The total weight they lift is 785 tons at Fontinettes, and 1,037 tons at La Louvière, while the heights of the lifts are 43 feet and 50½ feet respectively.

— Professor Baker of the Illinois University says in a letter to the *Clay Work* on the sustaining strength of brick-work, "By actual experiments in a testing-machine, the average strength, from fifteen experiments, of piers laid in ordinary brick and common lime mortar, using the same care as that with which ordinary brick masonry is built, stood a few pounds (I am writing from memory) over 1,500 pounds per square inch, which is equal to 216,000 pounds per square foot, or the weight of a column of brick 2,000 feet high; with ordinary Portland cement mortar, the strength was, for a mean of eight experiments, 2,500 and some odd pounds per square inch, which is equal to 360,000 pounds per square foot, or the weight of a column of brick masonry 3,600 feet high."

— The naval board charged with the duty of supervising and reporting upon the test of the 15-inch pneumatic gun last January have just made their official report to the secretary of the navy, who pronounces it satisfactory. The report is to the effect that more than one-half the projectiles, fired at ranges of 300, 1,700, and 2,100 yards, fell within the specified target limits, an area of fifty by a hundred and fifty feet.

— The annual address of the president of the New York Microscopical Society, Charles F. Cox, read Jan. 4, 1889, was on "The Spontaneous Generation Theory, and its Relation to the General Theory of Evolution." The close of the address was as follows: "In the domain in which Mr. Darwin worked, I look upon natural selection as a well-established principle. In the developmental idea as extended and expounded by Herbert Spencer, I find much that appeals strongly to my sense of fitness and consistency, and, if possible, I could see the hypothesis become a proven law of nature without a shock to my mental or moral status. I have no fear of anything that is true. But what I have endeavored to show is, (1) that a transition from not-living matter to living forms is an essential step in the process of evolution; (2) that at the point at which experimental proof is applicable (namely, to present and continual archeobiosis), the theory of such a transition is discredited, if not disproved; (3) that scientists generally accept this conclusion, and that those who are not thorough evolutionists are confined to the mere belief that the step from the not-living to the living was taken at some remotely early period, beyond the reach of evidence. And finally, I submit, as a consequence of these premises, that the general theory of evolution is still in the stage of hypothesis, and that in the gap between lifeless substances and living forms we have the veritable 'missing link.'"

— Thanks to strict preservation, and to the fact that the inhabitants are realizing the value of the bird, according to *Nature*, the eider has greatly increased in number in Iceland during recent years. The people do all in their power to attract the bird to their property. Among these attractions are bells worked by the wind or by water, the hanging-up of dress material of a glaring color, and the keeping of brightly colored fowls. A society has been formed for the granting of premiums for the killing of animals preying upon the eider, and last year 1,155 such prizes were awarded.

— In a late number of *L'Architecture*, M. Edmond Pottier contributes a letter on antique polychromy, combating the idea that a Greek temple was an edifice painted in every part, from the steps to the cornice, which appears to be entertained by some French archæologists. He observes that no monument, except the temple at Ægina, offers traces of color on the shafts of the columns, and that a comparison cannot be instituted between that case and such a building as the Parthenon, inasmuch as the latter was in marble and the former in porous stone, to which it might have been thought desirable to give a surface finish of paint, without implying that the same treatment would be applied to marble.

SCIENCE:

A WEEKLY NEWSPAPER OF ALL THE ARTS AND SCIENCES.

PUBLISHED BY

N. D. C. HODGES,

47 LAFAYETTE PLACE, NEW YORK.

SUBSCRIPTIONS.—United States and Canada.....\$3.50 a year.
Great Britain and Europe..... 4.50 a year.
Science Club-rates for the United States and Canada (in one remittance):

1	subscription 1 year	\$ 3.50
2	" " 1 year	6.00
3	" " 3 year	8.00
4	" " 1 year	10.00

Communications will be welcomed from any quarter. Rejected manuscripts will be returned to the authors only when the requisite amount of postage accompanies the manuscript. Whatever is intended for insertion must be authenticated by the name and address of the writer; not necessarily for publication, but as a guaranty of good faith. We do not hold ourselves responsible for any view or opinions expressed in the communications of our correspondents.

VOL. XIII. NEW YORK, MARCH 8, 1889. No. 318.

CONTENTS:

SOME NEW ELECTRIC RAILWAYS.....	173	NOTES AND NEWS.....	180
HEALTH MATTERS.		EDITORIAL.....	182
Climate of Colorado.....	174	The Minerals of Manhattan Island.	
Overcoats.....	175	SCIENCE IN THE SCHOOLS.....	182
Swine or Man.....	175	THE COAL QUESTION IN ENGLAND.....	183
Air and Water Analyses.....	175	MINING INDUSTRIES IN SIAM.....	184
Baldness.....	175	BOOK-REVIEWS.	
Boston Milk-Supply.....	175	Popular Lectures and Addresses.....	184
The Microbe of Malaria.....	175	The Psychic Life of Micro-orga-	
Books from Circulating Libraries.....	175	isms.....	185
The Loco-Weed.....	176	AMONG THE PUBLISHERS.....	185
SCIENTIFIC NEWS IN WASHINGTON.		LETTERS TO THE EDITOR.	
Effect of Permanent Moisture on		The Soaring of Birds	
Certain Forest-Trees.....	176	J. G. MacGregor	187
MENTAL SCIENCE.		A New Departure in Effigy Mounds	
Statistics of Visual Images.....	177	T. H. Lewis	187
COMMERCIAL GEOGRAPHY.		QUERIES.....	188
An Agricultural Map of North			
America.....	178		

THE NEW YORK MINERALOGICAL CLUB is a society organized in 1887 for the purpose of studying the rocks and minerals of the city and vicinity, which present many interesting and remarkable features. Very few persons have any idea of the number and variety of minerals that are found in the rocks of Manhattan Island and the immediate suburbs. But in some respects this locality is peculiar, for the reason that while a large amount of excavation and rock-cutting is all the time going on, yet scarcely is a deposit of minerals discovered in the progress of any such work, ere it is built over or filled up, and rendered forever inaccessible. New York Island specimens, therefore, possess in this aspect unusual interest, and the collection and preservation of them become a matter not only of scientific value, but of local pride. During a number of years past, a gentleman well known, and greatly respected in cultured circles here, Mr. Benjamin B. Chamberlin, has devoted a great amount of time, labor, and care to gathering these specimens from all parts of the city, wherever excavations were in progress. At the time of his death, in October last, he had thus secured the finest cabinet of New York minerals ever obtained. Mr. Chamberlin was not a man of wealth, and labored in this field out of pure love for science. The New York Mineralogical Club is very desirous to obtain this collection by purchase, that it may be retained in the city in its entirety, and serve as the foundation of

a permanent local collection, which, for the reasons above given, must ever increase in value and interest as time goes on and the city is more and more built up. The moderate sum of fifteen hundred dollars will secure this very desirable object; and the trustees of the American Museum of Natural History have agreed to receive the collection on permanent deposit in their absolutely fire-proof building, where it will always be accessible for purposes of study, — a monument to the zeal and success of its honored collector, and a matter of interest and credit to the metropolis.

SCIENCE IN THE SCHOOLS.

THE committee on the subject of science in the schools, of the American Society of Naturalists, consisting of Samuel F. Clarke (Williams College), William North Rice (Wesleyan University), William G. Farlow (Harvard University), George Macloskie (College of New Jersey, Princeton), and C. O. Whitman (editor *Journal of Morphology*), have made a report which has been accepted and heartily approved by the society. The committee have been retained, and have been granted full power to act for and with the society in the endeavor to establish what they have recommended.

From the steadily increasing demand of scholars, parents, and teachers for more and better instruction in these departments, the committee feel assured that the time is ripe for this movement, and that it only needs intelligent and concerted action to produce the results desired. The society will be represented at the meetings of the various educational associations in the country, and will make every effort to push the movement as vigorously as possible. It needs, however, and asks for, the active support and encouragement of every parent and teacher who believes that the young should have their natural tendencies, and longings for a knowledge of the things of nature, cultivated; their questions about things which are in every way pure and true answered; opportunities for enjoyment, and for friendships that will never fail, laid open to them; and, above all, the opportunity freely afforded them for securing the brain-growth and mental power, by observation and independent thought, which these studies are so peculiarly well fitted to give.

In regard to the general topic of science-teaching in the schools, the committee believe the following propositions fairly formulate the views which are held by the members of the society, and which the society should use its influence to diffuse:—

1. Instruction in natural science should commence in the lowest grades of the primary schools, and should continue throughout the curriculum.

2. In the lower grades the instruction should be chiefly by means of object-lessons; and the aim should be to awaken and guide the curiosity of the child in regard to natural phenomena rather than to present systematized bodies of fact and doctrine.

3. More systematic instruction in the natural sciences should be given in the high schools.

4. While the sciences can be more extensively pursued in the English course in the high schools than is practicable in the classical course, it is indispensable for a symmetrical education that a reasonable amount of time should be devoted to natural science, during the four years of the high-school course, by students preparing for college.

5. An elementary (but genuine and practical) acquaintance with some one or more departments of natural science should be required for admission to college.

Believing that the propositions stated above will command general acceptance, they are aware that there must be difference of opinion, among the members of the society and among intelligent educators in general, in regard to details, and that the precise subjects to be introduced into the curriculum must vary somewhat with the circumstances of different localities. They offer the following, not as necessarily the best scheme, but as a reasonable and practical scheme, which may at least serve to illustrate the general principles which they have formulated.

In the primary schools, and in the lower grades of the grammar schools, they recommend that the study of plants and animals should be the main part of the scientific work. The botanical

instruction should commence with such simple exercises as drawing and describing different forms of leaves, and should gradually advance to the easier and more conspicuous flowers, and later to the more obscure and difficult forms of flowers, the fruits and seeds.

The zoological instruction in the lower schools should not attempt a systematic survey of the whole animal kingdom, but attention should be directed chiefly to the most familiar animals, and to those which the pupils can see alive. The common domesticated mammals should first be studied, and later the birds, the lower vertebrates, the insects, crustacea, and mollusks. While the range of zoological instruction must be limited as regards the number of forms studied, those few familiar forms should be so compared with each other as to give the pupils, very early, some conception of the main lines of biological study,—morphology, physiology, taxonomy.

Special prominence should be given to the study of plants and animals which are useful to man in any way; and the teacher may advantageously, from time to time, give familiar talks in regard to useful products of vegetable and animal origin, and the processes of their manufacture.

Attention should also be given to the more obvious characteristics of the kinds of minerals and rocks common in the region in which any school is situated, and to such geological phenomena as are comparatively simple and easily observed.

A most important feature of the scientific instruction in the lower grades should be to encourage the pupils to collect specimens of all sorts of natural objects, and to make those specimens the subject of object-lessons. The curiosity of the children will thereby be rationally cultivated and guided.

The subject of human physiology and hygiene is of so immense practical importance, and so few comparatively of the pupils ever enter the high school, that we regard as desirable some attempt to teach the rudiments of the subject in the grammar, and even in the primary schools.

They recommend the introduction of exceedingly rudimentary courses in physics and chemistry in the highest grades of the grammar school, and further, as perhaps the most desirable branches of science to be included in the classical courses in the high school, and to be required for admission to college, physical geography, phænogamic botany, and human physiology. The first is suggested as tending to keep alive in the student's mind a sympathetic acquaintance with nature in its broader aspects; the second, as affording unequalled opportunities for discipline in observation; the third, as affording knowledge of the greatest practical importance.

The rudiments of physics and chemistry, which they propose for the grammar schools, will enable physical geography and physiology to be intelligently studied in the early years of the high-school course.

For the scholars in the English course in the high school, there will naturally be more advanced and systematic instruction in chemistry, physics, and zoology, and also instruction in geology and astronomy; but the classical students may with propriety leave these studies until they reach them in the college course. The scientific instruction they will have received in the primary and grammar schools, and the study of the three branches above specified in their high-school course, will be sufficient to preserve that natural and wholesome sympathy with nature the loss of which is now the main obstacle to the successful study of natural science in the colleges.

THE COAL QUESTION IN ENGLAND.

MR. R. Price Williams, M.Inst.C.E., read a paper on the "Coal Question" at the meeting of the Royal Statistical Society on Feb. 19. The following is an abstract of the paper as given in *Engineering* :—

After paying a well-deserved tribute to the labors of the late Professor Jevons in connection with this subject, the author shows, by a series of tabular statements and diagrams, the rapid increase in the coal-production of England prior and subsequent to the date of the coal commission in 1871. The Northumberland and Dur-

ham coal-field, as is pointed out, still gives to Newcastle its pre-eminence as the chief source of the coal-supply, the output last year from Durham alone amounting to over 28,750,000 tons, or to more than one-sixth of the total production in the United Kingdom. Attention is drawn to the fact that during the last four or five years there has been a considerable decrease in the output from these northern coal-fields; and the maximum limit of the coal-production it is considered has been reached, and henceforward it will continue to decline. It is shown, that, at the average rate of increased production during the last twenty-two years, the 9,294,000,000 tons of available supply would be entirely exhausted in about ninety-four years.

The author devotes a considerable part of his paper to the South Wales coal-field,—a district he is well acquainted with,—and attention is directed to the remarkable development which has occurred during the last few years in the South Wales steam coal-trade, the 26,000,000 tons produced last year coming next in amount to that of Durham. This large quantity is shown (after allowance is made for waste in working) to represent about 5,381 acres of a four-foot-thick coal-seam practically worked out in the course of a single year. The total available supply in the South Wales coal-basin is estimated by the coal commissioners at 36,566,000,000 tons, or just one-third of the whole available supply in the United Kingdom, which, at the rapid rate of increased production which has obtained during the last quarter of a century, would, as the author shows, be entirely exhausted in the short space of seventy-nine years.

The rapid development in the coal-production in the eastern division of this coal-field, which contains the famous steam coal-measures, is strikingly shown by the enormous growth of the coal-exports from Cardiff, more especially to foreign countries. In 1864 these only amounted to 1,500,000 tons, doubled in the next ten years, and again doubled in the following seven years; while in 1887 they amounted to 8,250,000 tons, or to more than a third of the entire coal-exports for the United Kingdom for that year.

Two-thirds of the South Wales coal-supply is obtained from Glamorganshire, more particularly from the eastern division, containing these valuable steam coal-seams. The author shows, that, if the production from this eastern portion of the coal-basin continues to increase at the average rate it has done during the last twenty-four years, the whole available supply, which the coal commissioners estimated at 12,963,000,000 tons, will be entirely worked out in the course of the next sixty years; and the portion containing the lower or steam coal-seams, in the short space of forty-two years.

The coal exported from Cardiff, consisting chiefly of this high class of coal, the author points out, represents, after making allowance for waste in working, about seven acres of the famous four-foot steam coal-seam entirely worked out during each working day of the year.

The coal-productions from all the other principal coal-fields are separately dealt with; and the dates at which, at the average increased rate of output during the last twenty-four years, they will become exhausted, are given in the following summary:—

	Years.
Northumberland and Durham	94
South Wales	79
South Wales (eastern division)	46
Lancashire and Cheshire	74
Yorkshire, Derbyshire, and Nottingham	90
Warwickshire	53
Denbighshire and Flintshire	250
Scotland	92
United Kingdom	102

Under the head of coal-consumption, particulars are given of the chief uses to which the coal is applied, from which it appears that the coal consumed in the manufacture of pig iron, and in the manufacture of merchant iron and steel of various kinds, amounted at the time of the coal commission to nearly one-third of the coal produced in the United Kingdom. The large economies since effected by the Bessemer, Siemens, and other processes, are shown, however, to have reduced the consumption in 1887 to little more than 16 per cent of the coal-production. Attention is drawn to the large economies effected and to be effected by the use of compound

engines for steam navigation and locomotive purposes. The amount of coal used by ocean-going steamers during 1887 amounted to nearly 7,000,000 tons, and that consumed by the much larger number of steamers engaged in the coasting trade is estimated to have equalled that amount. The coal consumed by the locomotives on the railways in England in the same year is shown to have exceeded 6,000,000 tons.

Particular attention is drawn to the very rapid growth of the export of coal, which has increased from 4,333,333½ tons in 1854, to over 27,000,000 in 1888. The author considers it is but the measure of increased commercial prosperity, and that to impose any tax upon such exports would be like killing the goose that lays the golden eggs.

The author, in his concluding remarks, observes, that, if the growth of the trade and prosperity of England is to continue as it has done in the past, its coal-production, which is at once the cause and effect of this growth, must necessarily keep pace with it; and it is pointed out that unless large economies, which can and ought to be effected in its consumption, are realized, all the largest and best sources of the coal-supply will be exhausted in the very short periods mentioned in this paper. The hope is expressed, that, by drawing attention to this most vital subject, further strenuous efforts may be made to husband English coal resources in every possible way, and to put a stop to the great waste in working the mines, and in the consumption of coal generally.

MINING INDUSTRIES IN SIAM.

SIAM is rich in minerals. Gold, iron, tin, and copper are found in many parts of the country; but the want of roads, and consequent difficulty of getting these metals to market, prevent their being worked, except for the limited wants of the natives.

The English consul at Bangkok, Mr. Child, says, in his last report, an abstract of which appears in the *Journal of the Society of Arts* for Feb. 22, that the eastern part of Siam is very rich in iron, antimony, and argentiferous copper and tin. It is from the provinces of Petchaboon and Löm that the cutlasses, spears, and knives are furnished to all the provinces of the north and east. Silver is not found in Siam.

As regards gold, this metal is found in many places, but the mines at Bang Tapan on the west coast are said to contain the purest gold in the country. They have been worked by the natives by simply turning over the ground, the gold being found in the shape of nuggets. When nuggets over a certain size were found, the miners were obliged to hand them over to the government, but they were paid for the same according to a tariff fixed by the authorities.

A syndicate of foreigners has been formed, with a concession from the king, for working these mines, and has now a number of workmen employed, the prospects for rich developments being good.

The quartz-mines of Muang Krabin, although productive, were declared unprofitable to the government. Experienced engineers from Australia, mining machinery of recent invention, immense upright pumps and other hydraulic machinery, and a narrow-gauge railroad with rolling stock for the conveyance of the product, had been procured for the working of the mine; but, the organizer of the great scheme having been decapitated for alleged treason, the whole of the plant is lying idle.

The royal metal of Siam is mostly manufactured into vases, teapots, betel-boxes, and other articles, which it is the custom of the kings of Siam to present to subjects upon their elevation to high rank in the peerage of the kingdom. They are looked upon in a sense as insignia of their exalted rank, the shape and style of the set denoting the standing of the beneficiary.

It is impossible to procure statistics concerning the output of the mines. Iron of good quality is found in the eastern provinces, but it is worked in a very crude and primitive manner. Foundries are unknown. A hole or pit having been dug close to the mountain, the miner collects and piles up his ore, which he smelts with charcoal. The molten metal is deposited in a cavity prepared for its reception, and when cold the product is carried home.

There a fire is prepared, which is kept alive by a bellows made of two trunks of hollow trees buried in the ground, and having two long sticks as handles. A child works the bellows, while husband and wife or son hammer the iron into shape.

The knife, cutlass, spear, or agricultural implement produced by this combined labor finds a ready sale throughout the north of Siam, and, although the workmanship is poor, it suits the requirements of that section. The locality of the mines preclude shipments to Bangkok, as it would have to be conveyed to the river on elephants,—a method of conveyance too expensive for the commodity.

Tin is found in profusion in the Malayan peninsula, and is worked by Chinamen. It is generally exported direct to Singapore from the locality in which it is mined. Tin is also found in eastern Siam to a limited extent, but none of it finds its way to the capital.

Copper is found in certain localities, especially in the eastern provinces,—Champasak, Petchaboon, and Löm. In the former province, on the Makong River, there is a place where the natives procure the finest metal, of which they make a coin that passes current in that locality. It is about two inches in length, a quarter of an inch in breadth, and shaped like a canoe. The province adjoining that has an iron coin of the same shape, but larger in size. Virgin copper is held in great esteem by many for certain qualities it is supposed to possess when employed as an agent in transmuting metals. Without it as a basis, the native alchemists claim that gold cannot be obtained.

Coal is found on the coast and in the interior, but cannot be utilized. Limestone is brought to Bangkok from the interior. The lime is mixed with turmeric, and is used to a large extent by the Siamese in combination with the betel-nut and *seri* (pepper-leaf).

Precious stones come principally from the province of Chantibun; rubies, sapphires, topaz, asterias, and other stones being found in that district. The diamond is unknown as a native stone. The sapphire mines to the south of Chantibun, to which thousands of Burmese flocked a few years ago, have been exhausted.

BOOK-REVIEWS.

Popular Lectures and Addresses. By SIR WILLIAM THOMSON. In 3 vols. Vol. I. Constitution of Matter. London and New York, Macmillan. 12s. 3s.

THE author of this work possesses in an eminent degree the ability of putting into untechnical language those essentials of knowledge which are most interesting and attractive, and at the same time most useful, to the general reader. Among the contents of this volume may be mentioned "Capillary Attraction," which was originally delivered as a lecture before the Royal Institution in 1886; to which are added three appendixes treating of certain curious motions observable on the surfaces of wines and other alcoholic liquors, gravity and cohesion, and the equilibrium of vapor at a curved surface of liquid.

Shortly after the delivery of this lecture, it was suggested to Mr. Thomson that it might be advisable to make it more conveniently accessible to the general public than it could be in the "Transactions of the Royal Institution;" and it was accordingly arranged to bring out, as one of the Nature Series, a small volume containing the lecture mentioned, together with several other papers pertinent to the subject. While the volume was in course of preparation, it was decided to increase the size of it, adding several other lectures and addresses to the contents, and make it the first of a series of three volumes, constituting a reprint, in a revised form, of all Sir William's popular lectures and addresses. The result is the volume before us, the first volume of the series.

Besides the lecture already spoken of, a chapter each is devoted to the following subjects: "Electrical Units of Measurement," "The Sorting Demon of Maxwell," "Elasticity viewed as possibly a Mode of Motion," "The Size of Atoms," "Steps towards a Kinetic Theory of Matter," "The Six Gateways of Knowledge," "The Wave Theory of Light," "The Age of the Sun's Heat," and "Electrical Measurement." These were originally delivered as lectures and addresses before the Royal Institution, the Institution of Civil Engineers, the British Association, and the Franklin In-

stitute of Philadelphia. The chapter on "The Age of the Sun's Heat" is reprinted from *Macmillan's Magazine*, and consists of three parts, treating respectively of the secular cooling of the sun, the sun's present temperature, and the origin and total amount of the sun's heat.

The Psychic Life of Micro-organisms: a Study in Experimental Psychology. By ALFRED BINET. Tr. by Thomas McCormack. Chicago, The Open Court Publ. Co. 12°. 75 cents.

IT may, perhaps, not be rash to venture the statement that in no field of study has the introduction of the comparative method been so helpful as in the study of mental phenomena; of the coordinations between the organism and the environment. It is this that has widened the horizon of the psychologist from the observation of his own individual, adult, civilized consciousness, to the observation of other men and of other races in different stages of civilization, of other ancestries, of other no less interesting though more lowly forms of life, of the embryonic, immature stages of development. It is to the apparently most insignificant group of such phenomena that M. Binet devotes his monograph,—to the psychic life of the lowliest denizens of the earth, forms so simple that even the distinction between animal and vegetable becomes doubtful when their classification is attempted. Many a reader would perhaps be likely to think that an account of the psychic life of micro-organisms might be as brief as that celebrated essay on the snakes of Greenland, which was all contained in the sentence, "There are no snakes in Greenland." M. Binet shows most conclusively, however, that there is psychic life in these unicellular specks of protoplasm; that they exhibit relations to their environment similar in kind, though vastly inferior in degree, to those to which we unhesitatingly attribute an intellectual origin, when we observe them in ourselves or any of the higher animals.

M. Binet classifies these evidences of embryological mental activity into (1) those connected with motion and sensation, (2) those connected with nutrition, (3) those connected with reproduction, and (4) those connected with "social relations." Under the first head we observe that the *Didinium nasutum* (a type of the ciliated infusoria) has the power of reversing its motion, of arresting it, and that for this purpose it makes use of a perfect miniature steering apparatus. We note, too, that the most rudimentary sensation is that of contact, many of these microscopic animals having no other; that after this, sight develops, it being not improbable that certain vegetable forms possess the analogue of an eye. The *Didinium* has vision enough to hurl a shower of darts at its prey, thus paralyzing it, and making it an easy victim; while the *Euglena* are sufficiently sensible to color to constantly congregate between the lines F and G of the solar spectrum. The maintenance of life is always the result of a re-action to the environment, and in this "life of relation" a psychic element must enter. In the motions necessary to seize the prey, in the power of selection that enables the organism to seize certain particles and reject others, we have a rudimentary form of choice. In the recognition of the position of the desired food, M. Binet does not hesitate to detect an elementary space-perception. The excitement preceding the times for copulation shown by unicellular organisms suggests an analogue to the emotions. Under the fourth head belongs the formation of a group of cells into a colony, in which the individuals act harmoniously, and each contributes to the general welfare.

These are only a few of the very suggestive observations and comments that M. Binet brings together; and if from the rest of the work a single example of the possibilities this study reveals must be selected, it should be the experiments of Professor Pfeffer on the spermatozooids of ferns. This observer finds that when a solution of malic acid is held in a tube, and a similar solution of one-thirtieth the strength be placed in a watch-crystal in which are the spermatozooids, the latter will leave the watch-crystal for the tube; and not only this, but when the solution in the tube is only twenty times as strong, these organisms remain unaffected. It seems to be the ratio of the intensities of the two solutions that brings about the result, and in this Professor Pfeffer sees an undoubted analogy to the psychophysical law illustrated in the power to distinguish between sensations as tested by Weber, Fechner, and

others. If this law can be thus corroborated, it is a wonderful law indeed.

The general position of M. Binet is thus somewhat in opposition to current views. He combats the view that in the unicellular organisms we have a simple and blind mechanical reflex action between irritable substances and an irritating environment, but holds that rudimentary forms of various psychic functions take their origin here. He pronounces Mr. Romanes' attempt to fix the grade at which the several constituents of psychic function enter into play as artificial and arbitrary, and believes that a more complete study of these lowliest forms of life will establish a more rigid and scientific criterion of mind, and show the substantial unity and primordially of the psychic element. It is certainly a long step from the days when man was defined as a rational animal, denying by inference, to the rest of creation, a share in this possession, to the days when what we can see only with the aid of the most improved results of science is pronounced akin to the most human part of man.

AMONG THE PUBLISHERS.

THE *Atlantic* for March contains an article by Stuart F. Weld, on "The Isthmus Canal and Our Government," which will interest students of politics. The author is strongly in favor of placing the canal under international control, as the Suez Canal has already been placed; and he shows, by quotations from public documents, that our own government has always been in favor of such control, except during a brief period beginning with the administration of President Garfield. Another article of interest is "Personal Reminiscences of William H. Seward," by Mr. and Mrs. Samuel J. Barrows. Mr. Barrows was for a time private secretary to Mr. Seward at the State Department, and during an illness of some months his wife took his place. Hence they have much to tell us about the statesman's official and private life, and they tell it in a simple and pleasant way. Mr. John Fiske continues his articles on American revolutionary history, treating in his usual excellent style of "Ticonderoga, Bennington, and Oriskany." The *Atlantic* has also a paper on "Some Colonial Lawyers and Their Work," by Frank G. Cook, which lawyers will like to read, and the usual variety of lighter articles.

— Mr. John Delay of this city has begun the publication of a series of Gleanings from Foreign Authors, the first number of which now lies before us. It contains "A Love Match," translated from Ludovic Halévy, and "King Apepi," by Victor Cherbuliez. The former is a very pleasant little love-story told by the lovers themselves in extracts from their diaries, which they read to each other after their marriage. The other is less agreeable as a whole, but ends in an amusing and unexpected way. We are not told whether the whole series of which this book is the beginning is to consist of novels, but they will doubtless constitute the greater part; and, if the other volumes are up to the level of this one, they will make an addition to the lighter literature of English readers.

— *Outing* for March is a sporting number. We note the following principal articles: "Fox-Hunting; A Day in the Shires," by Henry H. L. Pearse; "Lawn Tennis in the South," by Henry W. Slocum, jun.; "Snowshoeing in Canuckia," by James C. Allan; "Salmon-Fishing on Loch Tay," by "Rockwood," and illustrated by J. & G. Temple; "Spaniel-Training," by D. Boulton Herral; "How to Cycle in Europe," by Joseph Pennell; "Amateur Photography," by Ellerslie Wallace; "Winter Shooting in Florida," by F. Campbell Moller; and "Coaching and Coaching Clubs," by Charles S. Pelham-Clinton.

— A catalogue of the contents of the *Magazine of American History* for March reveals great current interest. The leading article describes the "Historic Homes and Landmarks" about the Battery and Bowling Green, New York City. The whole procession of Dutch and English governors who resided in the old historic fort opposite the Bowling Green are passed in review, as well as those who lived in the house built for Washington on the same site. One of its features is the sketch of the site of the City Hotel, of

which so little is generally known. The second article, "America: the World's Puzzle in Geography," is a study by Rev. William Barrows, D.D. President James C. Welling, of the Columbian University, Washington, D.C., replies to Gen. Wilcox in an article on "The Mecklenburg Declaration of Independence;" the well-known author, J. G. Rosengarten, contributes "Du Pont De Nemours;" Gen. Alfred E. Lee discourses upon "German Family and Social Life;" Mr. Maturin L. Delafiel writes of Col. Henry Beekman Livingston; and Annie E. Wilson gives an authoritative paper entitled "Thrilling Adventure of a Kentucky Pioneer."

—"The Century Dictionary" is to contain some features new in dictionaries, one of which is the entry of every thing in the one alphabetical order, abbreviations and foreign phrases as well as common words. While the plan of the work excludes biographical and geographical names, yet such adjectives as "Chinese," "Darwinian," etc., derived from proper names, will find place, and be fully defined. A great point with the new dictionary is its encyclopedic treatment of words. It will not stop at definitions, but is said to go into particulars about things to a greater extent than any other book except an encyclopaedia, and it gives the information in a condensed, usable form. Such terms as "Bright's disease," "Tweed Case," "electric light," etc., are defined under the words "disease," "case," "electric," etc. Under "case" there are twenty-seven entries of such terms as "Dred Scott Case," "Tichborne Case," etc., in addition to the etymologies and definitions usually to be found in a dictionary. Such terms as "credit mobilier," "bankruptcy laws," "crossed checks," "clearing-house system;" the names of foreign administrative divisions, such as "arrondissement;" legislative bodies, like the "Cortes" and "Bundesrath;" parties and classes, such as "Anarchist," "Nihilist," "Chartist," "Fenian," "Carbonari," etc.—will be fully defined in "The Century Dictionary;" and it is even understood that the new use of "barrel" ("the money, especially when the sum is large, supplied by a candidate in a political campaign for campaign purposes, but especially for corrupt purposes, etc.") has found a place.

—In the twenty-four years since the late Mr. N. Trübner began to carry out, under the title of *The American and Oriental Literary Record*, the idea of supplying periodically, not only lists of books published in the various countries of the East and throughout the whole of the American continent, as well as of European works bearing upon those countries, but also literary information on books and their authors, the value and usefulness of the *Record* have been fully recognized throughout the literary world. The growing importance and rapid spread of scientific research in the United States on the one hand, and the ever-increasing interest which literary men in England take in the history, antiquities, and civilization of the East on the other, have made it appear desirable to the publishers to expand the original design of the *Record* by assigning ample space to literary and scientific articles on subjects within its scope. They are making this departure with the greater confidence of success, as there is no other periodical in the English language which offers such a solid and comprehensive programme; and, while they invite the co-operation of scholars in the special departments to which their studies are directed, they look forward for continued support to the literary public generally, who have for so many years accorded to the *Record* their signal approbation and patronage. With a view to securing, as far as practicable, the indispensable superintendence by a competent and experienced editor, of the Oriental section of the expanded issue, they have made arrangements with Dr.rost, of the India office, to undertake the editorial management; and they are confident, that, in intrusting this department to his care, they can rely upon its being directed with impartiality and independence of judgment. In addition to personal notices, such as obituaries and literary notes of works projected or in progress, the publishers intend to devote more space to reviews, independent articles on Oriental subjects, and more especially to periodical statements as to the advance made in the various fields of Oriental research, so as to make the *Record* a depository of information concerning the current state of Eastern literature in all its branches. It is proposed as a first and tentative venture to issue six numbers

annually, which will be published regularly in the middle of every alternate month, each issue to be a full record of the events of the two preceding calendar months. But the publishers hope that they will soon be enabled to issue the *Record* monthly. This, of course, will depend upon the success of their venture. The price of the new series, the first number of which will appear on the 15th of March, 1889, will be ten shillings per annum, payable in advance, or two shillings per number.

—The *Electrical World*, March 2, says: "Last week we reached our highest water-mark, up to that time, in an issue of 72 pages, the size and contents being such as to bring in upon us overwhelming congratulations from friends and readers all over the country. Marking as it did the close of our fifteenth year, the issue was naturally taken as a good exemplification of the great growth of electrical science and industry in the period since the first number was published in 1874; and we felt that at so memorable a milestone on the road of progress we might fairly take the advice once given by a famous statesman after a noteworthy achievement, and 'rest and be thankful.' But we are called upon this week once more to meet larger demands, and, rising to the occasion, we now put forth a number containing no fewer than 96 pages, or a gain of 24 pages over the previous record of a single week before. We cannot but call attention to a stride so tremendous. There is no need for us to enlarge upon it, or to emphasize its importance as evidence of the enterprise of electrical journalism in America, and the vast extent attained by the department represented in the arts and sciences. The number speaks for itself, from the first line to the last, and, big as it is, we know that every page will be turned and read with interest." Notwithstanding the fact that a full report of the Electric Light Convention was given, the current electric news was not neglected.

—The *Forum* for March contains the first of a series of essays on the fine arts. It is by Charles Elliot Norton, and is an attempt to give a definition of the fine arts,—a task of no small difficulty. The author thinks they may be defined as "the arts of expression in forms of beauty created by the imagination," and supports this view by an able discussion. He holds that these arts are "the only real test of the spiritual qualities of a race;" and he has some very uncomplimentary but, we fear, very true remarks about the deficiencies in this respect of the American race. Another article in the *Forum* which at first attracts attention is that by Cardinal Manning on "The Bible in the Public Schools;" but the article itself is disappointing. It is little more than a tirade against the public schools themselves as being irreligious; and, as for the reading of the Bible in the public schools of this country, he opposes it, though he is glad it is read in the schools of England. Mr. St. George Mivart has an article on "Darwin's Brilliant Fallacy," in which he reiterates his well-known views in opposition to the theory of "accidental variations," holding that a new species arises from "pre-ordained, definite variations due to the spontaneous reaction of the innermost nature of an organism." The article contains nothing particularly new, but in another paper the author promises to consider the subject of human reason, and to show that its origin is not explainable by Darwinism. Besides these papers, the *Forum* has one by Miss Kate Stephens on "Advanced Education for Women," showing the rapid progress that such education is making; another by Dr. Bacon, advocating the delivery of letters by carriers from every post-office in the Union; and other articles on various topics, which we have not space to particularize.

—Roberts Brothers will soon publish a new edition of "A Modern Mephistopheles," which first appeared in the No Name Series. The author's name, Louisa M. Alcott, is now printed on the title-page for the first time. It was one of the famous No Names, the authorship of which was never guessed by any one. The story resembled Hawthorne's style so much, that at its publication many attributed it to him. Appended to the volume is another story called "A Whisper in the Dark,"—a story written many years ago, but which never appeared in book-form.

—The *Revue Scientifique* proposes to open its columns to a symposium of facts relating to heredity in man. Its object is to collect reliable instances of unusual cases of heredity, and to subject the material thus gathered to a rigid analysis, in the hope of

shedding new light on this most important topic. The editor of the *Revue*, M. Ch. Richet, the well-known physiologist and psychologist, requests that all who have facts to present will send them to him. His address is 111 Boulevard Saint-Germain, Paris, France.

—Harper & Brothers have just ready "The Correspondence of John Lothrop Motley," edited by George William Curtis. Mr. Motley's daughters have collected these letters, chiefly addressed to the writer's family and to Oliver Wendell Holmes. They contain the autobiography of one of the most striking figures in American literary history. The author of "The Rise of the Dutch Republic," "History of the United Netherlands," and "The Life and Death of John of Barneveld," studied the history of liberty in an essentially American spirit. Wendell Phillips was his school chum, Bismarck his fellow-student at Göttingen; and as United States minister to London, Holland, and Austria, he made personal friends of all the literary and political celebrities of his day. Few lives have been so full of incident of universal interest. The work is in two volumes, and has a portrait.

—The Leonard Scott Publication Company (New York, 29 Park Row) has reprinted the famous Bismarck Dynasty article from the *Contemporary Review* for February (price 15 cents), a large special edition of that number having been exhausted on the day of publication. The authorship of the article continues to be the theme of much speculation in England. The Empress Frederick has thought it necessary to disclaim it, and so has Sir Morell Mackenzie. Many of those who claim to know, attribute it to Mr. Stead, the editor of the *Pall Mall Gazette*. Mr. Labouchere says he almost knows it was Mr. Stead, and sundry characteristics can be pointed out which lend color to this view. In the mean time eight editions of the *Review* have been called for in England.

—A novel feature in magazine literature was introduced in the *Nineteenth Century* for February. The editor has invited a number of his friends to send him from time to time, in the shape of letters to himself, remarks upon any books which in the ordinary and natural course of their reading may strike them as being worth special attention. He has suggested to them, that, whenever a book is thus met with, a letter about it should be written to him, giving the same advice as to a friend, and in much the same sort of easy fashion. He hopes in this way to obtain fresher and more spontaneous criticism than can possibly be always produced under the prevailing system of "noticing" books "sent for review." The first instalment of this series consists of a notice of Margaret Lee's novel "Divorce," by Mr. Gladstone; of the "Lyrics," and "A Village Tragedy" by Margaret Woods, by Frederick Harrison; Dean Burgon's "Lives of Twelve Good Men," by P. E. Prothero; Sir George Young's "Sophocles," in English, by W. S. Lilly; "Notes of Conversations with the Duke of Wellington," by Augustine Birrell; Miss Rives's "The Quick or the Dead?" and "Virginia of Virginia," by Hamilton Aide; M. Jusserand's "Wayfaring Life," by the Rev. Dr. Jessop; and George Pellew's "In Castle and Cabin," by John Morley.

—The New England Publishing Company have just published "One Hundred Lessons in Composition," by W. H. Huston of Toronto, which contains 400 practical exercises in composition, and is the sixth volume in their library of Teachers' Help Manuals. It will shortly be followed by "Manual of Rhymes, Selections, and Phrases," by Oscar Fay Adams; "Forty Friday Afternoons," by forty prominent masters, each giving what he considered his best exercises for a Friday afternoon; and "Common-Sense Exercises in Geography," a book of exercises—not questions—adapted to all grades and to the best American text-books. They have also just ready "School Music," by W. S. Tilden, of the State Normal School, Framingham, Mass., a series of papers from the *American Teacher*.

—The *Critic* observed the seventieth anniversary of the birth of Mr. Lowell, which occurred on Feb. 22, by printing seventy letters and poems from American and English men and women of letters, among whom are Tennyson, Whittier, Gladstone, Holmes, and Stedman.

—Mrs. Frank Leslie has sold to W. J. Arkell, of *Judge*, her *Frank Leslie's Illustrated Newspaper*, both English and German,

the transfers to be made May 1. Mrs. Leslie will retain and personally direct her other publications.

—Emin Pacha forms the subject of a paper by Elbridge S. Brooks in the February *Wide Awake*.

LETTERS TO THE EDITOR.

*.*Correspondents are requested to be as brief as possible. The writer's name is in all cases required as proof of good faith.
The editor will be glad to publish any queries consonant with the character of the journal.

The Soaring of Birds

MAY I ask space for a few comments on Professor W. H. Pickering's letter on the above subject, in *Science* of Feb. 22?

Professor Pickering holds that a bird which is moving with motionless wings in a horizontal wind is acted upon by three forces: (1) its weight; (2) a force "due to the excess of the velocity of the wind over the velocity of the bird," by which, since it is represented as horizontal and to leeward in his diagram, I suppose he means the friction between bird and wind; and (3) a force "due to the resistance of the air acting on the wings of the bird," which I take to mean the force derived from the impact of the air particles on the wings. This third force he assumes to have a direction opposite to that of the resultant of forces (1) and (2), and therefore to have one component vertically upward, and another to windward. This assumption seems to me to be erroneous. The horizontal component of such a force must surely be to leeward, as was pointed out by Hubert Airy in *Nature*, xxvii. p. 336; and the inaccuracy of this fundamental assumption of Professor Pickering would seem to invalidate his whole argument.

But let us follow it further. Force (3), he says, depends on the velocities of bird and wind, and he assumes first that these velocities are such that it is equal to the resultant of forces (1) and (2). In that case he says the forces acting on the bird will be in equilibrium. They would be, certainly, if the above assumption were true. "The bird," he then says, "will therefore continue to revolve about its mean position." How can a body which is in equilibrium revolve about a mean position? It must surely move with a uniform velocity in a straight line. He says again, "While these forces are in equilibrium, the bird is slowly drifting in the same direction as the wind." Why so? If the bird is in equilibrium, he must have the same velocity as he had at the instant at which he came to be in equilibrium, and that may or may not have had the same direction as the wind. In fact, if it is true, as Professor Pickering assumes, that the forces acting on the bird can be in equilibrium, the bird can move to any distance, in any direction whatever, with motionless wings. He has but to get up a velocity in the desired direction by using his wings, and then to poise his wings so that the forces acting on him may be in equilibrium. Since this result is contrary to experience, it makes the possibility of the bird's being in equilibrium under the given conditions doubtful; and it is obvious, that if force (3) has a leeward component, as I hold it must, its being equal to the resultant of (1) and (2) does not involve the vanishing of the resultant of all three; indeed, that whatever assumption may be made as to the magnitude of (3), the resultant of (1), (2), and (3) cannot possibly be zero.

Finally, Professor Pickering assumes the velocities of wind and bird to be such as to make force (3) greater than the resultant of (1) and (2). In that case, if the assumption criticised above were correct, the bird would be acted upon by a resultant force directed upwards and to windward, as Professor Pickering states. But if force (3) is directed upwards and to leeward, it will be obvious that the resultant force on the bird will be necessarily directed to leeward, and will not necessarily be directed upwards; and it follows, that, even if the velocities of wind and bird be assumed to be such that force (3) is greater than the resultant of (1) and (2), the bird's path will not necessarily have a general upward direction.

J. G. MACGREGOR.

Dalhousie College, Halifax, N.S., Feb. 27.

A New Departure in Effigy Mounds.

It was first asserted by Dr. J. M. De Hart that there are to be found exceptions to the ordinary rule followed by the mound-builders in the outlines of their quadruped animals; i.e., that in-

stead of portraying them with legs in range of the eye, so that only two are visible, there are cases in which all four legs are shown. This statement occurred in an article written by him on the mound-builders of Wisconsin, which appeared in the "Proceedings of the Wisconsin Academy of Sciences for 1876-77;" and he furnished illustrations of two such animals which he found on the northern shore of Lake, or Fourth Lake, opposite Madison. One of them he considered to represent a deer with divided horns: the other he called a bear.

Now, this report of his did not go uncontradicted; for it was maintained some years later by a writer in the *American Antiquarian* (vi. p. 13), that "there is in the mound no such divisions in the legs or horns," and the doubt is also expressed "whether any effigy intended to represent a deer ever had the horns separate, as this has." Dr. De Hart does not seem to have written in defence of his position, and no one hitherto seems to have taken up the cudgels in his behalf. For my part, until last year, I shared equally in the doubts of the second writer, because, in addition to scrutinizing all the drawings of effigies by Mr. Lapham and others contained in the "Antiquities of Wisconsin," together with a few subsequent incidental surveys of similar figures, I had personally examined some hundreds of original effigies in the field, without being able to find a case of divided legs.

When visiting the Four Lake country last summer, I did not fail to search for, and find, the two effigies delineated by the doctor, which are on the grounds of the insane-asylum. The result of the examination did not entirely confirm his statement; for, though the "deer's" legs are most decidedly apart, there is no division of the horns into antlers that I could discern. The following descriptions,

subdivision. There are several other effigies and a number of round mounds and embankments belonging to this group, but they are being gradually defaced and worn away by the patients passing back and forth over them in their daily walks.

On the same occasion I also found another four-legged animal (No. 2) not hitherto mentioned by any one. It is on the north side of Lake Wingra, nearly five miles distant as the crow flies, in a southerly direction from the one first described. The length of this effigy from the extremity of the muzzle to the rump is 127 feet, its body is 3 feet in height, and the legs are bent as if in motion. Last August, when I made the survey, it was in a fine state of preservation, the base outline being well defined. It is located on a knoll about twenty feet above the lake, less than one hundred feet from the shore; and on a high ridge above and to the east of it there are numerous round mounds, embankments, and effigies.

Leaving the vicinity of Madison, a north-westerly course in an air line of about 117 miles by the map brings us to a place where there is another effigy belonging to the same class (No. 3). It is located on the farm of Mr. George Gale on the N $\frac{1}{2}$ of section 10, township 18, range 8, on the west side of Black River, in Trempealeau County, Wis., within seven miles of the Mississippi River to the south-west. Its length from the muzzle to the tip of the tail, in an air line, is 234 feet, and the body is 2.5 feet in height. In this case, also, the horns, if such they be, are divided. The fore-legs are bent forward, and the hind-legs backward, which is probably intended to convey the idea that the animal is in motion. The tail is 144 feet in length, being just one and a half times that of the body and head combined. In addition to this one, there are four other effigies and several round mounds and embankments belonging to the same group, all of which were in a fine state of preservation last November, when my survey was made.

While these three examples, representing probably very different animals, are entirely unlike each other generally, they are yet fully sufficient to establish a class of four-legged ones; and probably by continued research others could be found in the same regions.

It may be further noted, in connection with these earthen effigies, that occasionally carvings or etchings are found on the sides of rocks and caves in Trempealeau and adjoining counties, which represent a great variety of figures of various kinds, and that among them are found some animals with two and others with four legs. The more interesting specimens of work have been copied by me. Although they may have been carved by another race, yet the fact still remains that both the artists in earth and the artists in stone adopted the same plan of outlines, but among the carvings there is by far the largest proportion of four-legged animals.

Whether this departure from a supposed rule be symptomatic of any incipient æsthetic evolution or not, and whether such construction of figures with legs apart preceded, was contemporaneous with, or succeeded, the similarly shaped carvings on the rocks, are questions which must be left to the future to answer.

T. H. LEWIS.

St. Paul, Minn., Feb. 27.

Queries.

42. LOOKING TO THE LEFT. — A writer in a recent number of the *Albany Argus* asks, "Why do theatre-goers prefer seats on the right of the house?" and suggests that when we are on the street we pass persons to the right and look to the left; that twenty-five or thirty years of this sort of thing naturally gets one accustomed to it; and, finally, that if one were to sit for two hours and a half or three hours in one position, if he has to keep his eyes to the right, he will find that it tires the muscles of the eyes quite perceptibly. Is there any evidence that this explanation is well founded?

43. DIGESTION OF FOWLS. — Permit me to ask a few questions about the digestion of fowls. Do they pick up the little stones when chicks, that serve through life, or do they secrete an acid that gradually digests even the pebbles, or have they a normal condition which produces the gravel in their gizzards as it is required for digestion?

S. E. W.

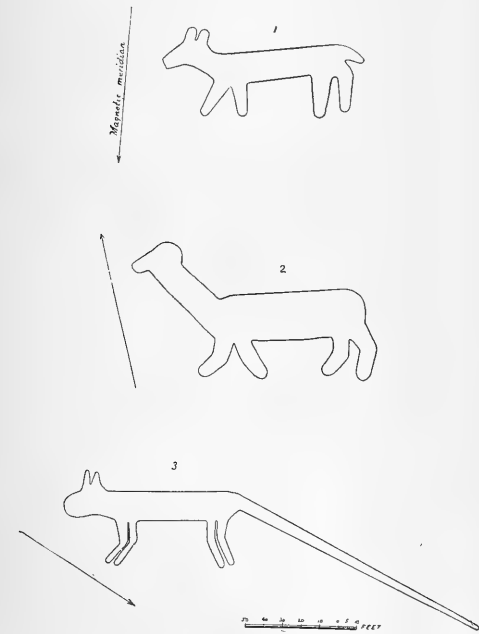

with outline diagrams plotted from my surveys, are now submitted to the archaeological world to substantiate the position taken.

The deer, so called (No. 1), is situated to the right of the road running from the asylum to the lake, and about equidistant from each. Its greatest length from the muzzle to the end of the tail is 108.5 feet, and the body is 1.5 feet high. Its horns or ears, whichever they may be, are divided into two sections, but there is no

GUARANTY INVESTMENT COMPANY

CAPITAL \$250,000.

Hon. ALBERT H. HORTON (Chief Justice, Kansas Supreme Court), Topeka, Kan., Pres't.

7% Guaranteed Farm Mortgages 7%

The Company calls the special attention of Investors to the following points :

- I. All loans guaranteed and interest payable semi-annually at the Importers' & Traders' National Bank, New York.
- II. Unusual fulness of information, not only about the security itself, but about the general development of the section where the farm is located.
- III. An examination each year of the general business of the Company and the Mortgages themselves by a COMMITTEE OF INVESTORS sent for the purpose.
- IV. Many hundred Mortgages taken and NOT A SINGLE FORECLOSURE.
- V. Exhibitions in New York at frequent intervals, of Kansas and Nebraska Farm Products. The Exhibition at the American Institute in the fall of 1888, received the *HIGHEST AWARD* of superiority.
- VI. Monthly Bulletins giving full information about all Mortgages offered for sale.

Address for Monthly Bulletin and Investors' Committee Report for 1888,

HENRY A. RILEY, General Eastern Manager, 191 Broadway, N.Y.

The Travelers of Hartford,

PAID POLICY-HOLDERS

\$200,000 in January, 1889, Alone.

This enormous mass of claim payments—by far the greatest ever made by THE TRAVELERS in a similar period since its organization—came out of the Company's treasury in *one month*; a rate which if maintained would carry its payments for the year up to \$2,400,000. Any other company of the sort in the country would have been totally swamped by it. THE TRAVELERS' beneficiaries did not have to wait action and payment one day.

Assets, \$10,383,000. Surplus, \$2,041,000.

THE CHEQUE BANK LIMITED.

ESTABLISHED IN LONDON, 1873.

CHIEF OFFICE, 4 Waterloo Place, Pall Mall, London.

TRUSTEES:

The Right Honorable JOHN BRIGHT, M.P.
The Right Honorable EARL BEAUCAMP.
Bankers: Bank of England.

The Capital of the Bank and its Guarantee Fund of 500 is invested in Government Securities.
The Bank does not discount Notes or Bills, nor speculate, but loans its Deposits against Government Securities, thus making the Cheque Bank Cheques EQUAL TO CASH—as Bank of England Notes are.

The Cheque Bank issues Cheques singly or in books from ONE POUND upwards, for the use of Travellers, and for others remitting money to Europe, available in every town in England, Scotland, Ireland, and Wales. In every town of Europe, and all other parts of the world, Cheque Bank Cheques are accepted as Cash by all the British Government Offices.

VISITORS TO THE PARIS EXHIBITION this summer can get the Cheque Bank Cheques cashed at 50 Banking Houses in Paris.
Travellers and those holding Cheque Bank Cheques can have their mail matter addressed to them, care of the Cheque Bank, London, who will take charge of the same and forward it to any address.

For Hand-Book containing List of upwards of 2000 of the principal Banking Houses throughout the World who Cash the Cheque Bank Cheques, and for all information, apply to the AGENCY,

CHEQUE BANK, Limited,

UNITED BANK BUILDING,
2 Wall St., New York.

E. J. Mathews & Co., Agents.

REFERENCES BY PERMISSION:

JNO. W. MACKAY, Esq., President Commercial Cable Company, Mackay-Bennett Cables, New York.

F. O. FRENCH, Esq., President Manhattan Trust Co., New York, and others.

A NEW MAGAZINE—THE SWISS CROSS

Devoted to spreading a love of Nature among the people. Edited by HARLAN H. BALLARD, President of the Agassiz Association, and succeeding St. Nicholas as the official magazine of that body. \$1.50 a year. Sample copy 10 cents, or 25 cents for trial subscription for 3 months.

N. D. G. HODGES, PUBLISHER,
Mention this paper. 4 Lafayette Place, New York.

Old and Rare Books.

A. S. CLARK, Bookseller,

34 PARK ROW, NEW YORK CITY.

A Gleaner in the By-ways of Literature. Results of Gleaning found in Catalogues issued from time to time.

CATALOGUE NO. 27 NOW READY.

BACK NUMBERS and complete sets of leading Magazines. Rates low. AM. MAG. EXCHANGE, Schoharie, N. Y.

H. WILLIAMS,

Dealer in Old Magazines, Reviews, &c. Scientific periodicals a specialty. 39 Macdoug St., N. Y.

A Novel by the Author of 'The Story of Margaret Kent.'

A DAUGHTER OF EVE.

1 vol., 12mo, \$1.50.

"Exceptional cleverness, effective satire, a great deal of humor."—Boston Advertiser.

"A story that for rare merit and interest will surpass even either of this author's former novels that have won such a place in the literary world."—Home Journal.

"Graciously winning as was 'The Story of Margaret Kent,' brilliant and moving as was the tale of 'Queen Money,' we are strongly inclined to say, after reading 'A Daughter of Eve,' that the author has attained to a still more gratifying artistic triumph than in the case of either of the other two novels we have mentioned. Brilliant sparkle and wit 'A Daughter of Eve' has in abundance, but it also has a definite ethical motive treated with inimitable taste."—Beacon.

STEADFAST.

By ROSE TERRY COOKE. 1 vol. 12mo. \$1.50.

"A tale of far more than ordinary worth. Intensely interesting."—Boston Gazette.

"Will interest those who are attracted by 'Robert Elsmere' and 'John Ward.' It is rare pleasure to read the story for its style alone, if for nothing more."—Conrad.

"Mrs. Cooke's knowledge of Yankee dialect is unsurpassed, and the conversations are often inimitably humorous."—Springfield Republican.

GREAT CAPTAINS.

By COL. THEODORE AYRAULT DODGE, U.S.A. 8vo.

With 21 maps. \$2.00.

"We are apt to think that books dealing with the details of warfare are dry. Colonel Dodge, however, is anything but dry. He makes the course of a campaign as fascinating as a romance."—The Beacon.

"ALEXANDER, HANNIBAL, CÆSAR, GUSTAVUS ALOLPHUS, FREDERICK, NAPOLEON, and the record of their achievements."—Boston Post.

Sold everywhere. Sent, postpaid, on receipt of price by the Publishers,

TICKNOR & CO., Boston.

Readers of Science

Corresponding or visiting with Advertisers, will confer a great favor by mentioning this paper.

Schools.

NEW JERSEY, PLAINFIELD.

THE CHESTNUTS.—Parents with daughters to educate, or orphan girls with companion, may find a comfortable home, with school instruction by applying to Miss E. E. Kenyon.

CONNECTICUT, NEW HAVEN.

MRS. CADY'S SCHOOL FOR YOUNG LADIES. Prepares for Smith and Wellesley, and admits to Vassar by Certificate. Circulars. Early application necessary.

VERMONT, BURLINGTON.

VERMONT EPISCOPAL INSTITUTE. Boarding School for Boys. Prepares for College or Business. Military drill. Terms moderate. Fifty-seventh half-year opens September 3, 1885. Send for catalogue. H. H. ROSS, A.M., Principal.

JOHN HASTINGS = Pres't.
A. R. HART = Gen'l Manager
JOS. TRIPP = V. Pres't.

ENGRAVING FOR ALL ILLUSTRATIVE AND ADVERTISING PURPOSES

67-71 PARK PLACE, NEW YORK.

ESTABLISHED 1859.

H. A. DREW,

Commercial Printer,

5 Clinton Place, near Broadway, New York.

Wedding Orders, Souvenirs, Invitations, Orders of Dance, etc., etc., done in the latest and most elaborate styles, at reasonable prices. All Favors promptly attended to.

16 PAGES. THREE 18 PAGES.

Hundred Thousand new subscribers for The Family Journal and Ladies Companion wanted. It is the most interesting and instructive paper ever issued. Subscribers will receive during the coming twelve

MONTHS

novels written by American Authors, complete in such three numbers. The story of popular works of fiction will be retold by a novel reader, the most interesting and unique feature ever introduced in any publication. The catalogues of popular and standard books by famous writers in a space easily read by the busiest people. We have engaged

FOR

this work a widely known and popular writer. Comments on Current Events, Fashions, New and Original Ideas and Designs for Ladies' Fancy Work and Household Decoration, Letters from Correspondents and their Answers, the colleges and universities of the United States will be treated one each month in an illustrated article, showing the particular advantage of each, cost of attendance, etc. Invaluable to parents having sons or daughters whom they desire should receive the advantages of a higher education than the ordinary school affords. Articles on Painting and Drawing, giving home instruction by a well-known artist. A trial subscription of elegant paper will be sent to any address, three months, for

TEN CENTS.

Liberal pay for literary work adapted to our columns, and for new and original drawings, designs and ideas on any subject which we can use.

Premium List the most complete in the world. We offer inducements to club raises and awards approached by no other publishing house. The celebrated Gilbert Cut Waist Liners, which we send post paid, to any one sending us two yearly subscribers at 60 cents each is alone worth 10 cents. Sent to any address, postpaid one year, 50 cents; six months, 25 cents, and a three months' trial subscription for only 10 cents.

TRY IT! TRY IT! TRY IT!

and you will become a permanent reader. Address:

John L. Douglass, Publisher,
322 Broadway, N. Y.

Brokers and Auctioneers.

R. ELLIS & CO.

BUSINESS, HOTEL AND PATENT BROKERS,

AUCTIONEERS, ETC.

No. 176 BROADWAY,

Room 46. New York

Clients Advised free of charge.

J. P. TRAYER & CO.,

General Auctioneers,

Real Estate and Business Brokers,

OFFICE, 23 PARK ROW,

OPPOSITE POST OFFICE, (ROOMS 14 & 15) New York.

Mortgages Foreclosed. Cash Advanced on Consignments.

Property of Every Description Bought, Sold and Exchanged.

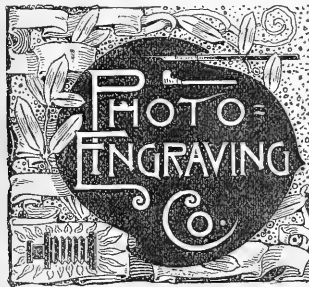

BRANCH AT 728 CHESTNUT ST.
PHILADELPHIA, PA.

C. & C. ELECTRIC MOTOR COMPANY.

Electric Motors
FOR
Arc and Incandescent Cir-
cuits, Most Economi-
cal Motor on the
Market.
Regulation Perfect.
Motors Designed for all
Power Purposes.

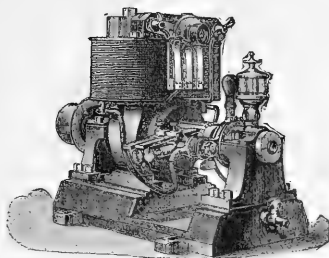

OFFICE and MANUFACTORY:
402 and 404 Greenwich Street, New
York City.
New England Office, 19 Pearl St., Boston.
Philadelphia Office, 301 Arch St.
Western Office, 139-141 Adams Street,
Chicago.
Southern Office, 25 Carondelet Street,
New Orleans.

THE

American Bell Telephone COMPANY.

95 MILK ST., BOSTON, MASS.

This Company owns the Letters
Patent granted to Alexander Gram-
bell, March 7th, 1876, No. 174,465,
and January 30, 1877, No. 186,787.

The Transmission of Speech by
all known forms of ELECTRIC
SPEAKING TELEPHONES in-
fringes the right secured to this
Company by the above patents, and
renders each individual user of tele-
phones, not furnished by it or its
licensees, responsible for such un-
lawful use, and all the conse-
quences thereof and liable to suit
therefor.

A TEMPORARY BINDER
for *Science* is now ready, and will be mailed
postpaid on receipt of price.

Half Morocco - 75 cents.

This binder is strong, durable and
elegant, has gilt side-title, and allows
the opening of the pages perfectly
flat. Any number can be taken out
or replaced without disturbing the
others, and the papers are not mudi-
lated for subsequent permanent bind-
ing. Filed in this binder, *Science* is
always convenient for reference.

N. D. C. HODGES,

47 Lafayette Place, N. Y.



GOOD NEWS TO LADIES.

Greatest inducements ever of-
fered. Now's your time to get
up orders for our celebrated
Teas and Coffees, and secure a
beautiful Gold Band or Moss
Rose China Tea Set, Dinner Set,
Gold Band Moss Rose Toilet Set, Watch, Brass Lamp,
or Webster's Dictionary. For full particulars address
THE GREAT AMERICAN TEA CO.,
P. O. Box 288, 84 and 88 Vesey St., New York.

Readers of Science

Corresponding with or visiting Advertisers
will confer a great favor by mentioning the paper.

Scientific Apparatus.

J. GRUNOW,

621 Sixth Avenue, New York.
Established 1854.

MAKER OF

Microscope Stands,
Oil Immersion Object-
ives and Abbe Con-
densers for Bacterial
and Histological work,
of Objectives, Camera
Lucida and other ac-
cessory apparatus.

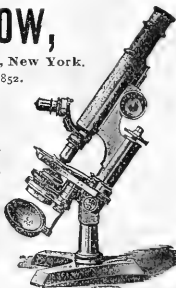

IMPROVED OIL LIGHT MAGIC LANTERNS.

Also Lime and Electric Light Apparatus, and
mechanical, plain, and fine colored views.

J. B. COLT & CO., Manufacturers,
No. 16 BEEKMAN STREET, NEW YORK.

MAGIC LANTERNS Stereopticons and the Best Views
for Public Church, Home, and
Scientific Exhibitions. Best appar-
atus, new views. Largest stock. Reduced prices. 24
Years' Practical Experience. Illus. Catalogue Free.

GEO. H. PIERCE,
136 S. Eleventh St., Philadelphia, Pa

ELECTRICAL TESTING BUREAU,

Johns Hopkins University, Baltimore, Md.
Resistance Coils and Boxes Compared.
Am meters and Volt meters calibrated.
Condensers standardized.
Primary and Secondary Batteries Tested.
Efficiency of Dynamos and Motors Deter-
mined.
Insulation of Cables and Wires Tested.
Etc., Etc.
Circulars describing Methods Used, Prices,
Etc., sent on Application.
Address as above.

W. H. WALMSLEY & CO.

SUCCESSORS TO
R. & J. BECK,
1016 Chestnut Street Phila

Microscopes and all
Accessories and Ap-
paratus. Photograph-
ic and Photo-Micro-
graphic Apparatus and
Outfits.
Spectacles, Eye
Glasses, Opera and
Marine Glasses, etc.
Illustrated Price List
mailed free to any ad-
dress. Mention SCIENCE
in corresponding with us.

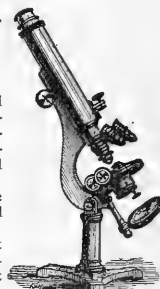

E. & H. T. ANTHONY & CO.
501 Broadway, N.Y.
Manufacturers and Importers of
PHOTOGRAPHIC INSTRUMENTS,
Apparatus and Supplies of every
description. Sole proprietors of
the Patent Detective, Fairy, Novel,
and Bicycle Cameras, and the
Celebrated Stanley Dry Plates.
Amateur Outfits in great variety, from \$9.00 upward.
Send for Catalogue or call and examine. More
than 40 years established in this line of business.

**WHITALL'S PLANISPHERES OR DI-
RECTORY OF THE STARRY HEAVENS**
name and locate all Stars, Constellations, and
Planets visible at any given minute of time.
Should be used by every one. Ask your sta-
tioner, or address Wm. T. COOPER, Manager,
307 Race St., Philadelphia, Pa.

SCHOOLS AND COLLEGES
will have a positive advantage by ordering their furniture
apparatus and supplies from **C. PARDO & CO.,**
31 East 17th St., New York.

TO EMPLOYERS.

Having purchased the fixtures, good will, &c., of
the **NEW YORK EMPLOYMENT BUREAU**, at No. 681
BROADWAY, in this city, we request the par-
ticipation of the public in the future. We desire to
fill a long-felt want for an employment bureau,
where only the best grade of male help is dealt in,
and it is our aim to send ONLY such help as is or-
dered in every instance, and our patrons can rely
on us to send strictly first-class help, the references
of whom we personally investigate before sending
to any one. We simply request a trial, and are con-
vinced that we will give satisfaction in every case.
We have on hand help in every branch, which we
can send upon receipt of telegram or letter, AND
FOR WHICH WE MAKE NO CHARGE TO AN EM-
PLOYER.

NEW YORK EMPLOYMENT BUREAU,
(AS REORGANIZED).

CALIGRAPH

MEDAL AWARDED!

GREATEST SPEED ON RECORD!!

126 words per minute, errors excluded.

T. W. Osborne, winner of international contest at Toronto, wrote on the Caligraph Writing Machine 630 words in five minutes, thus gaining for the Caligraph the championship of the world.

30,000
in
Daily Use.

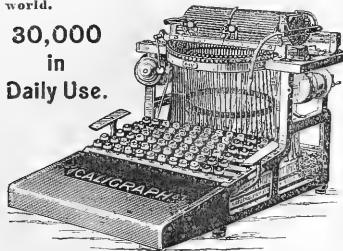

For full and correct account of above test, address
THE AMERICAN WRITING MACHINE CO.,
HARTFORD, CONN.

New York Branch, 237 Broadway.

KNABE

PIANOFORTES.
UNEQUALLED IN

Tone, Touch, Workmanship and Durability.

WILLIAM KNABE & CO.
NEW YORK: No. 112 Fifth Av., above 16th St.
BALTIMORE: Nos. 22 and 24 E. Baltimore St.
WASHINGTON: No. 817 Market Space, 9th St.

ESTERBROOK

STEEL PENS.

OF SUPERIOR AND STANDARD QUALITY.

Leading Nos.: 048, 14, 130, 135, 239, 333
For Sale by all Stationers.

THE ESTERBROOK STEEL PEN CO.,

Works: Camden, N. J. 26 John St., New York.

SPECIAL TEACHER'S EXCURSION TO

PARIS EUROPE

AND THE
WORLD'S EXPOSITION,
visiting England, France, Germany, the
Rhine, Belgium and Holland. All travel and
hotels FIRST CLASS. Finest line of Steamers cross-
ing the Atlantic. Low Rates. Rooms are being
rapidly taken. Send for circular, free.
E. TOURJEE, Franklin Square, Boston, Mass.

FOOD ADULTERATION

And its Detection. With photomicrographic plates and a bibliographical appendix. By J. P. Battershall. 328 pages, 8vo, cloth. Price, \$5.50. Circulars and Catalogues on application. E. & F. N. SPON,

12 Cortlandt St., New York.

KIMBALL'S STRAIGHT CUT CIGARETTES.

Unsurpassed in quality.
Used by people of refined taste.
Highest award at Brussels, 1888.
The finest smoking mixtures are of
our manufacture.
Fifteen First Prize Medals.
WM. S. KIMBALL & CO.,
Rochester, N. Y.



REMINGTON STANDARD TYPEWRITER

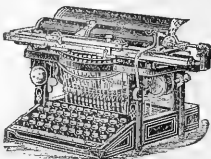

WON
Gold and Silver Medals

FOR
CHAMPIONSHIP OF THE WORLD.

At Toronto, in open contest, Aug. 13, 1888.

151 Words per Minute, Without an Error.

The above is an authentic record made by Mr. Frank E. McGurrin, at Detroit, on Jan. 21, 1889, on a memorized sentence, thus beating all previous records of correct work, by 30 words per minute and placing the "Remington" still further beyond reach of competition. Photographic copies of certified work furnished on application. WYCKOFF, SEAMANS & BENEDICT, 327 Broadway, N. Y.

Arnold, Constable & Co. SPRING WOOLENS.

English Suitings,
KERSEYS, VENETIANS and MELTONS,
For Ladies' Walking Jackets and Long
Coats.

"Vervier" Wool and Silk Mixed Cos-
tume Cloths

SCOTCH AND IRISH CHEVIOTS,

New Styles for Steamer Wear,
Tennis Cloths and Holland Cricketers.
LADIES' CLOTHS.

Novel Colorings for Jackets and Suits.

Broadway & 19th St.
New York.

DRESS GOODS FOR SPRING

JAMES McCREERY & CO.

Are now exhibiting their Novelties
in Dress Goods for Spring and Sum-
mer.

An extensive variety of fine wool
and silk mixed fabrics, in new
shades; Summer Tweeds, with
handsome selvages; French Cheviots
with Shepherd Check side band;
and many other new styles.

Advance styles in Figured Chal-
lie; India silk in Exclusive de-
signs; Mohair, Brilliantine and
Pongee Gloriosa in a fine range of
colors.

JAMES McCREERY & CO.

BROADWAY AND ELEVENTH STREET,
NEW YORK.

A YOUNG MAN can have lucrative engage-
ment, not only a fixed salary, but accord-
ing to his work accomplished in travelling for
SCIENCE. A personal interview invited.

N. D. C. HODGES.

47 Lafayette Place, New York

A Useful and Handsome Present

Prices Reduced for the Holidays.

The Hulin's Fountain Pen

Warranted 14 karat gold and to give perfect satis-
faction — is produced by hundreds of pleased cus-
tomers to be the best fountain pen in the market be-
cause it is always ready. Writes freely and never
gets out of order.

Sent by mail prepaid for \$1.50, \$2.00 and \$2.50
each, according to size selected.

These are special prices for the holidays, and this
offer should be availed of by all who write.

JOHN S. HULIN,
Mfg Stationer and Steam Printer.

Wedding Invitations and Visiting
Cards Engraved to Order.

369 BROADWAY, N. Y.
Near Franklin Street.

The Largest, Handsomest, and Most Complete
Account-Book Manufactory and Printing Estab-
lishment for Fine Commercial Work in New
York City.

What Scott's Emulsion Has Done!

Over 25 Pounds Gain in Ten Weeks.
Experience of a Prominent Citizen.

THE CALIFORNIA SOCIETY FOR THE
SUPPRESSION OF VICE.
SAN FRANCISCO, July 7th, 1886.

I took a severe cold upon
my chest and lungs and did
not give it proper attention;
it developed into bronchitis,
and in the fall of the same
year I was threatened with
consumption. Physicians or-
dered me to a more congeni-
al climate, and I came to San
Francisco. Soon after my
arrival I commenced taking
Scott's Emulsion of Cod Liver
Oil with Hypophosphites regu-
larly three times a day. In
ten weeks my avoirdupois
went from 155 to 180 pounds
and over; the cough mean-
time ceased. C. R. BENNETT.

SOLD BY ALL DRUGGISTS.

SCIENCE

[Entered at the Post-Office of New York, N. Y., as Second-Class Matter.]

A WEEKLY NEWSPAPER OF ALL THE ARTS AND SCIENCES.

SEVENTH YEAR.
VOL. XIII. No. 319.

NEW YORK, MARCH 15, 1889.

SINGLE COPIES, TEN CENTS.
\$3.50 PER YEAR, IN ADVANCE.

JOHN ERICSSON.

CAPT. JOHN ERICSSON died in New York at twenty-one minutes before one, Friday morning, March 8. He was cared for in his last moments by his attending physician, Dr. Joshua C. Boulee; his superintending engineer, V. F. Lassoë; and his secretary, S. W. Taylor. His last words were, "Give me rest," which followed an inquiry if he must die. Up to the last he retained his wonderful mental energy, his mind being concentrated on the work he had in hand.

The world has lost in this death one of its hardest workers, and one who has done his full share in advancing human welfare. So earnestly was he a worker, that he had not for years allowed any one to see him except on matters pertaining to his experiments. He would receive a tinsmith bringing a can for his laboratory; but he declined to meet Gen. McClellan, who expressed a wish to call on the great engineer. Even his associates could not induce him to break, in any case, this rule that he had made for his life.

His whole life was given to his work, and his only desire in living was to complete a task that he had set himself. For this reason he retained his residence

by the gloomy walls of the freight-depot of the New York Central Railroad. Its form, however, is the same as when Beach Street was one of the most aristocratic neighborhoods in the city.

His workshop was in the basement of his residence, and the whole building bore evidence of his vocation. The only ornaments in his parlor were models of his inventions, and a set of engraved resolutions passed by the New York Legislature in acknowledgment of his public services.

The first symptoms of the final illness appeared about three weeks ago, and, on account of his age, little hope was entertained from the first. But even on his death-bed his work was the one thing constantly before him; and among the last things he did was to leave special instructions to Mr. Lassoë, his assistant, for the completion of the work he was engaged in, the development of his sun-motor. He also left to Mr. Lassoë certain plans which he had originated for American coast defences.

Capt. Ericsson was born July 31, 1803, in the province of Wermland, Sweden. His father, Olof Ericsson, was proprietor of mines; his mother, Sophie, the daughter of an iron-master.

He was married in England about fifty years ago, but his wife has been dead a quarter of a century; and he leaves no children.



JOHN ERICSSON.

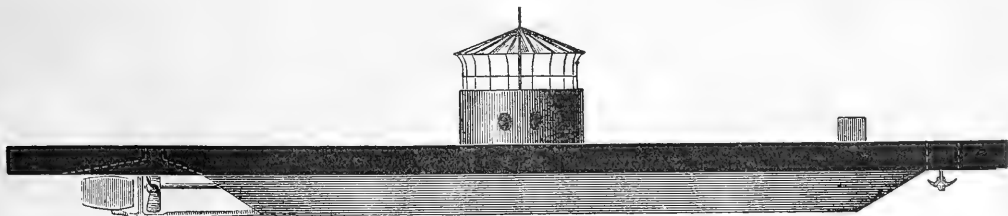

THE "MONITOR" OF 1862.

in Beach Street so long after the locality had been encroached upon by business structures and tenement-houses. This residence originally faced on St. John's Park, but is now shadowed

His special talent showed itself at the age of ten, when he constructed a miniature saw-mill and a pumping-machine that attracted notice. At twelve he was made a cadet of mechanical en-

gineers; the following year, a leveller on the canal. At seventeen, Ericsson entered the army as an ensign, and rapidly reached a lieutenantcy in consequence of his beautiful military maps, which had attracted the special attention of King Charles John (Bernadotte).

steam-engine, and a famous system of artificial draught for steam-boilers, dispensing with huge smoke-stacks, and economizing fuel. To the steamship "Victory," in 1828, he applied the principle of condensing steam and returning the water to the boiler; and four years later he gave to the "Corsair" the centrifugal fan-blowers

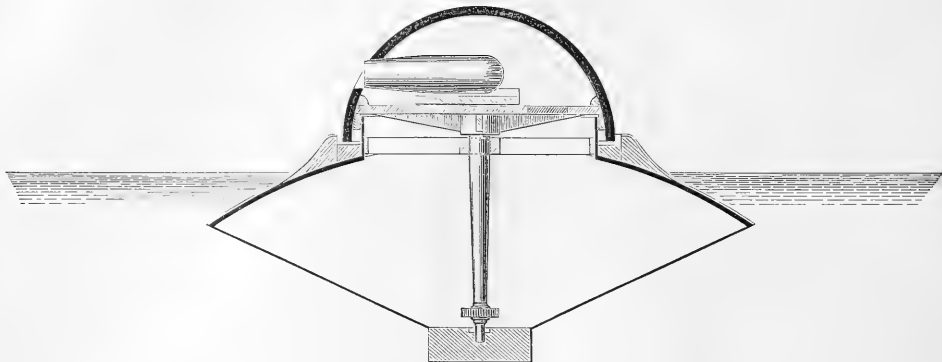

IRONCLAD CUPOLA VESSEL DESIGNED BY JOHN ERICSSON, 1854.

When about twenty-two years old, Lieut. Ericsson constructed a flame-engine of 10 horse-power, and journeyed to London in 1826, on leave, to introduce it. Once there, he resigned his commission. The resignation was accepted, but first he was promoted to a captaincy. He has never returned to his native country, but from it has received many honors and decorations; while in 1867 a great granite monument, quarried by the unpaid labor of the miners,

now generally used in American steam-vessels. In 1830 he introduced in the locomotives "King William" and "Adelaide" the link motion for reversing steam-engines. In 1834 he superheated steam in an engine on the Regent's Canal Basin.

In 1829 the Liverpool and Manchester Railway had offered a prize for competing locomotives. Ericsson planned and hurried to completion an engine, the "Novelty," in seven weeks. The London

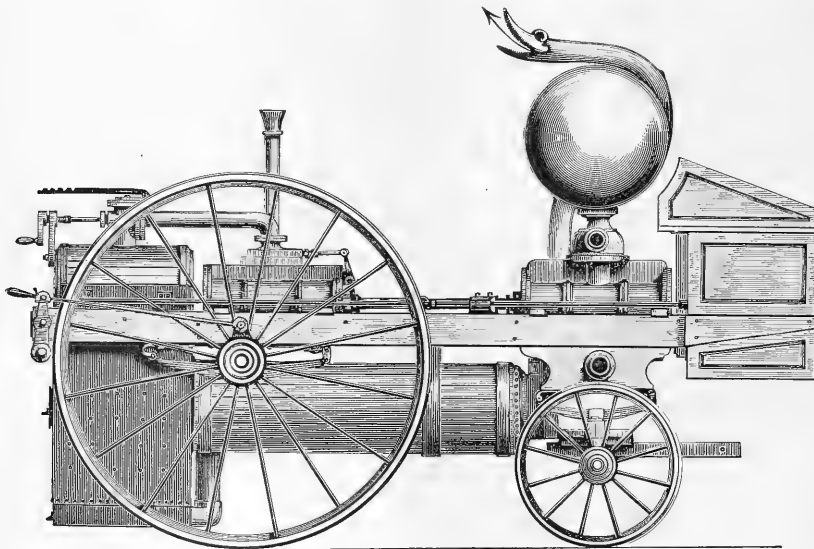

STEAM FIRE-ENGINE DESIGNED BY JOHN ERICSSON, 1841.

some of whom had worked for his father, was set up with gala festivities in front of his mansion, inscribed, "John Ericsson was born here in 1803." It is under this stone that his last resting-place may be, though at this writing nothing definite can be said.

During the next few years, Ericsson produced about forty machines. They included a file-cutting device, an instrument for taking soundings (still in use), a hydrostatic weighing-machine, an apparatus for making salt from brine, a pumping-engine, a rotary

Times of Oct. 8, 1829, said that in speed it "far excelled" all competitors. It shot along the line at the amazing rate of thirty miles an hour; but Stephenson's "Rocket" proved superior in point of traction. Ericsson in 1829, nearly threescore years ago, constructed a steam fire-engine, employed in putting out a fire in the Argyle Rooms, which was objected to as throwing too much water.

So much for his progress in England. For Ericsson's removal to

America in 1839, we have to thank the English Admiralty. In 1837 he built a tug, having two propellers of $5\frac{1}{2}$ feet diameter, invited the British Admiralty to inspect it, and towed their barge at a rapid rate; but their lordships solemnly concluded, that, as the motive-power was in the stern, the novel craft would not steer. Thus it was in America, in 1841, that he began to build the "Princeton," the first naval vessel that ever carried her machinery under the water-line, out of the reach of hostile shot.

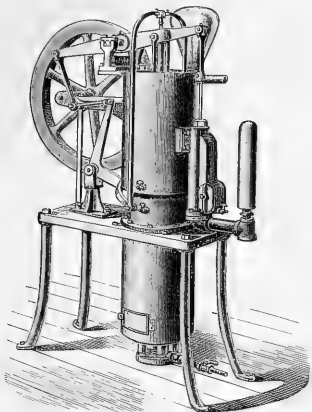

ERICSSON'S CALORIC ENGINE FOR DOMESTIC PURPOSES.

In 1839 Congress had authorized the construction of three war-ships. In 1840 the secretary of the navy, in obedience to that law, ordered two to be constructed. The question of whether steam could or could not be successfully applied to war-vessels had not then been solved, the fear of danger from ignition by fire prevailing in the minds of all naval men. One of the officers of our navy, Capt. William Hunter, submitted a plan by which wheels were to be inserted in the bilge of the vessel on each side,—submerged wheels. Ericsson had demonstrated his plan to be feasible, in his experiments in England. The secretary of the navy, in authorizing the construction of these two vessels, directed that one was to be built on Ericsson's plan, and one on Hunter's plan. Hunter's plan proved a total failure: Ericsson's plan laid the foundation of the present steam marine. The "Princeton" was the first war-propeller ever built on the face of the earth, and in her he brought forward not only his propeller, but a great many appliances appurtenant to steam navigation which have since been used in our service.

The honor of having built the first practical screw-steamer was thus Ericsson's,—an invention which was matched by that of the "Monitor," fifteen or twenty years later.

Such a device was offered by Ericsson in 1854 to Napoleon III. The story of what happened in 1862 is too well known to need repetition here. By extraordinary energy and executive skill, the "Monitor" was launched, with steam-machinery complete, a hundred days from the laying of the keel plate, and arrived in Hampton Roads just in time to defeat, March 9, 1862, the Confederate ironclad "Merrimac," which had destroyed the "Cumberland" and "Congress," and was about to sink or disperse the rest of the government's wooden fleet. Naval warfare was revolutionized.

The Mechanics' Institute of New York offered its great gold medal in January, 1840, as a prize for the best plan of a steam fire-engine. Ericsson, having several years previously designed such machines in England, among which may be mentioned the steam fire-engine employed during the memorable fire at the Argyle Rooms in London in 1830 (the first time fire had ever been extinguished by the mechanical power called forth by fire), had no difficulty in producing plans complying with the conditions of the Mechanics' Institute in a manner warranting the award of the prize offered.

His caloric engine was produced in 1833. In 1853, a voyage of the caloric ship "Ericsson," a vessel of 2,000 tons, 260 feet long, from New York to Washington and back, showed, that, though economical in fuel, the new heated-air motor could not produce speed enough at sea for commercial purposes, nor compete on any large scale with steam. Still, it has been applied successfully in thousands of engines to minor useful purposes.

Favored by the possession of a robust constitution and ample means, Ericsson devoted many of his last years exclusively to the investigation of solar heat, and to the determination of the mechanical energy which the sun has in store for mankind when the coal-fields become exhausted. A sun-motor (illustrated in *Nature*, xxix. p. 217) erected in 1883 was found to develop under ordinary sunshine a steady and reliable power. Although he was eighty-six years old, and by no means well since the beginning of the year, Capt. Ericsson continued to labor at this motor until within two weeks of his death; and, as he saw his end approaching, he expressed regret only because he could not live to give this invention to the world in completed form. It occupied his thoughts up to his last hour. While he could hardly speak above a whisper, he drew his chief engineer's face close to his own, gave him final instructions for continuing the work on the machine, and exacted a promise that the work should go on.

No visitor was allowed to enter his workshop. Even his most intimate friends have never gained entrance there. Nor has any servant been in the room where the captain spent more than twelve hours daily for thirty years.

Here in his workshop, as it were, Ericsson lived, and here he died, a recognized leader among those who have added to human welfare, and honoring by his name the rolls of more than a score of associations of learned men.

THE DENIO FIRE-ALARM.

WE illustrate herewith a simple automatic fire-alarm combined with an ordinary electric push-button, which is being manufactured by the Denio Fire Alarm Company of Rochester, N.Y. The construction and operation of the device will be readily understood from the following description. In a thimble with an internal flange at one end, an external hollowed flange at the other, is placed

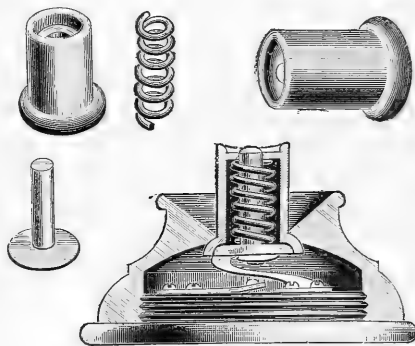

DENIO'S FIRE-ALARM.

a spring slightly longer than the thimble. This spring, one end of which bears against the internal flange, is compressed, and held in place by a pin which passes through it, the head of the pin fitting snugly in the recess made in the external flange of the thimble. The pin is sufficiently long to project entirely through the orifice in the internal flange end of the thimble. When the parts have been put together, the pin is secured in place by soldering to the flange, the solder used for this purpose being an alloy which will fuse at a low temperature, 150° to 160° F.

By removing the porcelain knob from any of the ordinary push-buttons now in use, and substituting this thimble, the button is

converted into an automatic fire-alarm, without in any way interfering with its use as a call. Pressure upon the thimble causes electric contact between the springs in the base of the button-fixture, in the usual manner, completing the circuit and ringing the bell.

AN IMPROVED ELECTRIC SYSTEM.

THE Sperry system of electric lighting, which has been widely introduced, especially in the Western States, has recently been considerably improved. The dynamo as now made is shown in

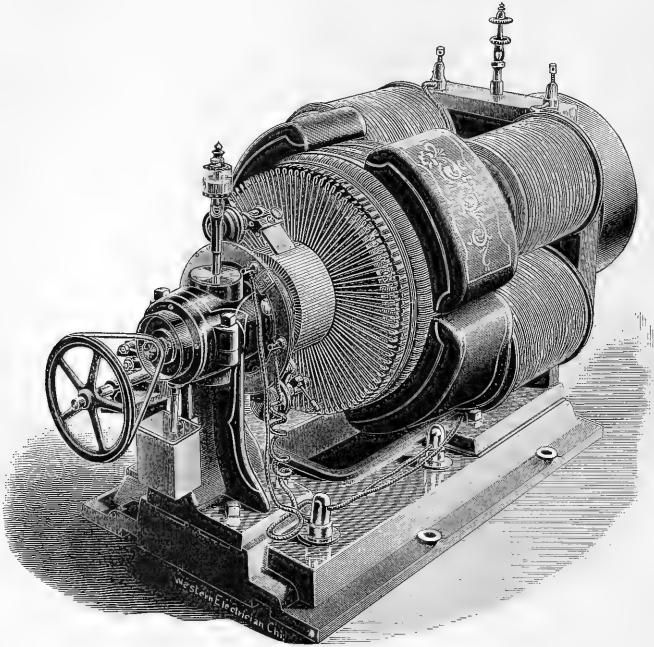
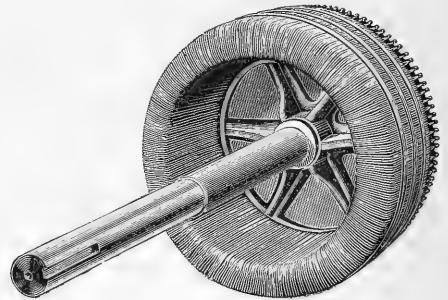
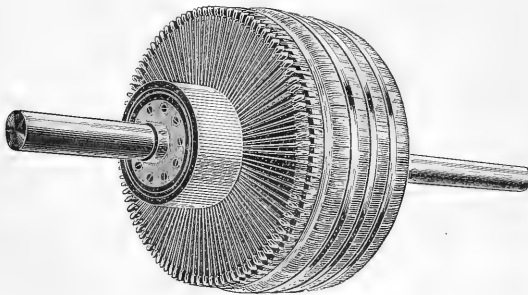

FIG. 1.—SPERRY DYNAMO COMPLETE.

As a fire-alarm, it operates as follows: When the heat of any room in which this attachment has been placed reaches a predetermined temperature, the alloy melts, and releases the pin, which is forced out of the thimble by the expansion of the spring. The springs in the fixture are then brought into continuous contact by

Fig. 1. A special feature of this is the automatic regulator. The brushes consist of overlapping flat copper strips attached to a movable yoke. This yoke is connected by means of an electro-magnetic regulator placed in the lamp-circuit. Any variation in the electrical resistance of the lamp-circuit operates the



FIGS. 2 AND 3.—ARMATURE OF SPERRY DYNAMO.

the pressure of the pin, the circuit is thereby closed, and the alarm transmitted to a central station, where measures can immediately be adopted for extinguishing the fire. The device is applicable to open or closed circuit, and to all purposes for which a thermostat is required. It is an efficient substitute for the more complicated and expensive thermostats, and should be very reliable, as the wires and connections are constantly being tested.

keeper of the electro-magnet. By an ingenious device, this movement adjusts the current of the dynamo in proportion to any variation in the resistance of the lamp-circuit. The manufacturer claims that all of the lights, a single light, or any number from zero to full capacity, may be extinguished without danger to the dynamo, and without the presence or knowledge of the dynamo-tender or engineer.

The field-magnets (Fig. 4) are provided with an annular recess, in which the annular armature (Figs. 2 and 3) rotates. It is claimed that by employing this peculiar construction of the armature, and

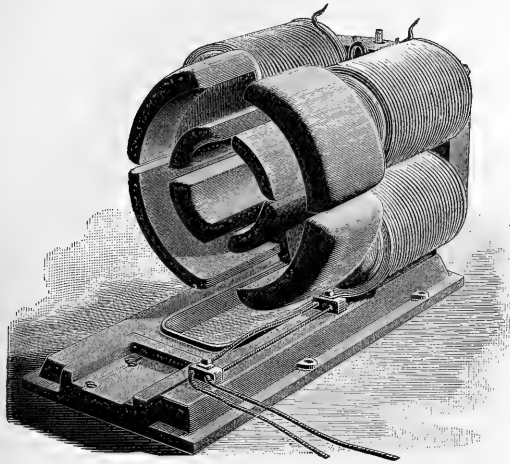

FIG. 4. — FIELD-MAGNETS, SPERRY DYNAMO.

exposing its inner surface to the action of the inner pole-pieces, the output of electrical energy is increased.

Another feature of the Sperry armature is that there is no overlapping of coils, each coil being separate and distinct from the

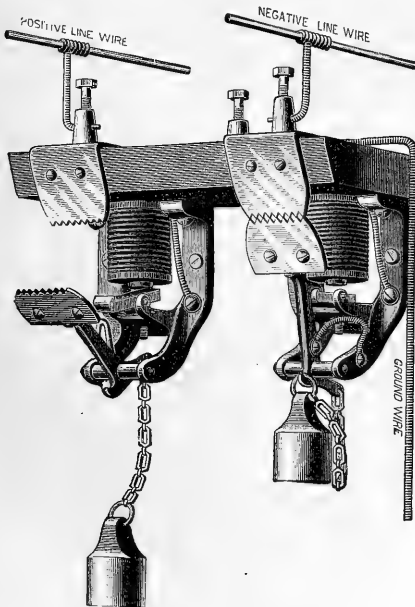

FIG. 5. — SPERRY LIGHTNING-ARRESTER.

others. Thus any mechanical injury sustained by one coil will not cause the destruction of the whole armature, as the injured part can easily be removed, and replaced by a new one, without disturbing any other coil.

Each lamp is provided with a hand-switch, and also an auto-

matic switch, which cuts the lamp out of circuit in the event of neglect or carelessness on the part of the trimmer, or trouble in the lamp itself. The regulation is such that the carbon rod is made to operate in both directions, up and down, without friction. On starting the machine, the normal arc is at once secured, and maintained throughout the entire operation.

The discharge-plates of the lightning-arrester are movable, one from the other, in such a way as to break the arc established between these two plates, which follows the discharge of static electricity from the line, be it produced by lightning or friction electricity by belts, which has been discovered to be the case in some instances. The arc being ruptured automatically, and the plates restored, no

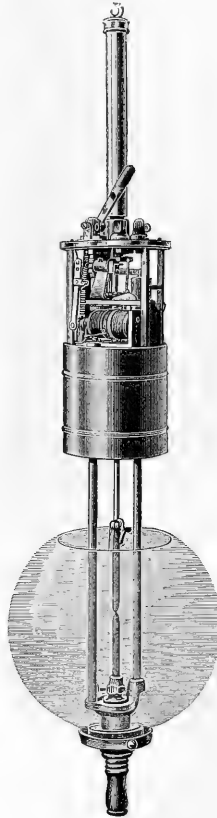

FIG. 6. — SPERRY ARC-LAMP, TOP REMOVED.

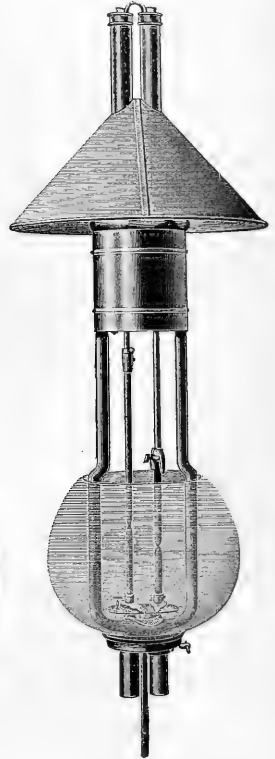

FIG. 7. — LAMP COMPLETE.

shutting-down of the light is necessary; and the consumer knows nothing of its operation, and is not annoyed by the extinguishing of his light. All possibility of disabling the dynamo from lightning is done away with, either from lightning direct or from the instantaneous short-circuiting of the dynamo, resulting from the arc established between the two leads by way of the two discharge-plates, which are present in all forms of lightning-arresters. These lightning-arresters have operated continuously for over two years upon sixty and eighty light circuits. Heavy discharges have been taken off of lines continuously all last summer and spring, and the apparatus has not been injured in the least. A single lightning-arrester serves for an entire circuit, being attached to both positive and negative wires between the dynamo and first lamps on either lead, the ground wire being attached to the rear terminal or binding-post, all of which are shown in Fig. 5.

GRAY'S TORSIONAL TESTING-MACHINE.

THE accompanying figure illustrates an apparatus recently designed by Professor Thomas Gray of the Rose Polytechnic Institute, Terre Haute, Ind., for the purpose of testing the torsional rigidity of different kinds of materials.

The figure has been prepared from a photograph of a rough and

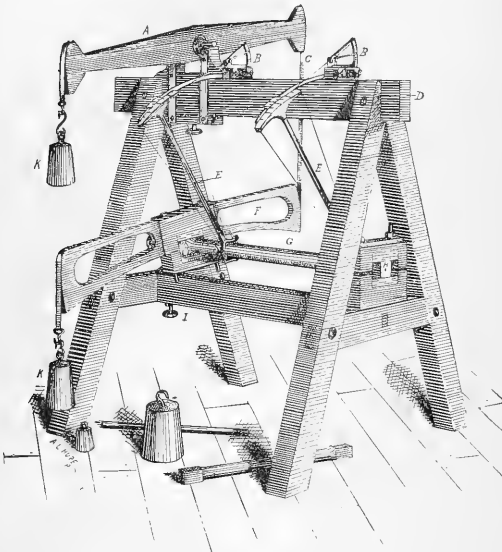

GRAY'S TORSIONAL TESTING-MACHINE.

inexpensive form of the machine, which was somewhat hurriedly made in the workshops of the institute by students, for use in the engineering laboratory course of the current year.

The apparatus, as here shown, consists of a wooden trestle, on the top bar, *D*, of which there is mounted a cross-beam *A*, about four feet in length, which rests, through knife-edges at its centre, on a support which can be clamped at any point of the bar *D*. The ends of this beam are cut to circles having the knife-edges as centre; and to one end a thin steel trap, *C*, is fixed, the lower end of which is attached to a cross-beam, *F*, of the same length as *A*. The beam *F* is clamped to one end of the specimen, *G*, which is being tested by means of strong clamps, which take different forms, and are made of different materials, according to the form and nature of the specimen. The other end is held in a similar clamp at *H*, and this clamp is firmly fixed to the trestle.

The end of the specimen to which the beam *F* is attached is kept in position by means of an attachment similar to the tail-stock of a lathe, the clamping-screw for which is shown at *I*.

This centre-bearing also prevents any cross-bending force being applied to the specimen by the weight of *F*. The torque, or twisting-couple, is applied to the specimen by hanging weights, *K*, *K'*, on the free ends of the beams *A* and *F*. These weights should be of equal amount, as they then produce a pure twisting-couple without applying any force to the centre-bearing.

The amount of distortion produced by any torque applied to the specimen is measured by means of two indices *E*, *E'*, which are clamped to the specimen at a measured distance apart. The outer ends of these indices carry a graduated arc, on which the angular displacement can be read by means of a fixed mark or vernier. For specimens of such large diameter that the limit of elasticity is exceeded before a sufficiently large deflection can be given to the indices *E*, *E'* to render this method sensitive enough, the deflection is indicated by a multiplying index, *B*. An important feature of this apparatus is the elimination of any uncertainty as to effect of

the clamps by measuring the relative twist at two sections a short distance from the ends.

This same method was adopted some years ago by Professor Gray, in a series of experiments on the elastic constants of rocks, but the apparatus was not then made in a permanent form. A considerable extension of the experiments is now contemplated in connection with investigations in seismology, under the direction of Professor Mendenhall, in which it is intended to determine the elastic constants of a number of rocks, for the purpose of ascertaining the theoretical velocity of a seismic wave.

In the more complete design of the testing-machine above described, both ends of the beam *A* are connected by straps or links to the beam *F*. The tail-stock centre-bearing is then omitted, and cross-bending stresses are avoided by mounting the clamp *H* on gimbals, which allow freedom to transverse motion. A graduated disk is then substituted for one of the indices *E*, *E'*; and the other index is carried on a bar which extends from the clamp, in a direction parallel to the axis of the specimen, up to the front of the graduated disk. The relative distortion is thus read off direct when that method is sufficiently sensitive, or by means of a second index attached to the disk when higher sensibility is desirable. For some purposes the gimbals are mounted on a worm-wheel, which turns round an axis parallel to the direction of the specimen, which thus allows an unlimited amount of twist to be given to the specimen. This becomes necessary when torsional strength is the object of investigation.

With the apparatus here illustrated, specimens of any length up to three feet can be included between the clamps; while specimens of any length can be tested in sections of three feet or less, the ends being simply allowed to project beyond the clamps, and the tail-stock bearing modified to a V instead of a centre-bearing. As regards the power of this machine, it is capable of testing a three-inch steel shaft up to its limit of elasticity.

THE MACRÆON SECONDARY BATTERY.

THERE is no field in which experiment is being more actively prosecuted than in that of the storage of electrical energy. From the experience which has been gained in the last five or six years, the failings of secondary batteries have become pretty well under-

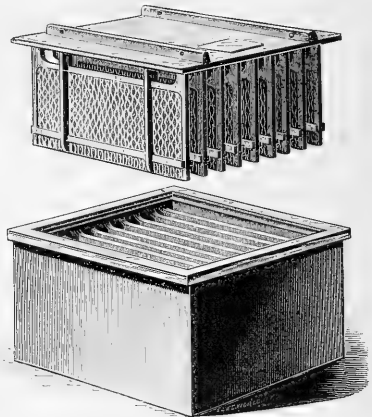

FIG. 1.—THE MACRÆON STORAGE-BATTERY.

stood, and many inventors are trying to remedy them. The two types of battery which have been at all generally used are the Faure and the Planté. In the former a support-plate is provided, and some salt of lead is mechanically applied to it, which forms the active material. In the latter the active material is obtained from the support-plate by reversing the current passing between two lead plates in dilute sulphuric acid. The Faure cells take but a very short time to manufacture: the Planté type takes several

months. The advantages of the Faure type are the ease of manufacture, and the capacity, which is greater than that of the Planté type. The disadvantages are in the rapid depreciation and the limited discharge-rate.

In the Macraëon battery the attempt is made to take advantage of the good points, avoiding the troubles. This is done in the following way. The negative plate is made according to the Faure process, as distinguished from the Planté. A framework of lead is filled in with active material obtained by fusion. The cross-bars making up the frame are thinner than the finished plate, so nothing but the active material is exposed to the liquid. The negative plates are permanently connected to the metallic box, which takes the place of the glass or rubber boxes now generally used.

The positive plates are made according to the Planté plan; the active material is obtained from the support itself by the chemical action of the current. But instead of the forming process taking months to accomplish, as in the original Planté process, it is accomplished in a few hours, the result of the special electrolyte used in the Macraëon battery. The form of the positive plate is also an important question. In this cell it is made of corrugated strips of

Portable Type for Railroad Purposes.

Size.	Normal Charging Current.	Normal Discharge Current.	External Dimensions.			Weight Complete in Pounds.	Normal Capacity in Amperé Hours.
			Length.	Width.	Height.		
D	20	1-25	11	5½	6¾	48	200
E	30	1-50	10¾	10	6½	78	350
F	1-2	1-3	3	4	6¾	-	8-9
G							
H							

ELECTRICAL NEWS.

The Velocity of Light.

ACCORDING to the electro-magnetic theory of light, which recent investigations, mathematical and physical, have rendered so probable, the velocity of light is equal to the quantity v , the ratio of the electro-static and electro-magnetic units of electro-motive force. Sir William Thomson has been engaged for some time on a series of measuring-instruments which will, by electro-static force, measure potentials from 40 to 50,000 volts. The method of calibration allows a determination of v to be made. The easiest way to get known potentials up to 200 or 300 volts is by sending a measured current through a known resistance, the difference of potential at the terminals of the latter being CR , the product of two easily measured quantities. This is the plan Sir William adopts for the calibration of instruments giving the lower readings, and the accuracy is within at least one-twentieth per cent. By the aid of condensers, these potentials are multiplied up to 2,000 or 3,000 with an accuracy of one-fifth per cent; and, by the aid of an intermediary electrometer, this is raised to 10,000 volts, with about the same limit of accuracy. This last measure, based on the original electro-magnetic determination with the resistance and current may now be compared with the electro-static measurement of the same potential made by an electro-static balance. Sir William has not been able to make sure of the accuracy of this last instrument to within more than one-half per cent, but within this limit the comparison of the two methods gives a ratio within one-half per cent of 300,000 kilometres per second. The velocity of light is known to be within one-fourth per cent of this value, — a most satisfactory agreement, speaking well for the accuracy of the new instruments.

The series of ammeters that Sir William lately developed will be of great practical benefit to electricians; their great range, accuracy, and permanence making them almost invaluable for certain classes of work. The series of volt-meters on which he is working will be of equal value, and we look forward to the time when they will have passed through the experimental stage.

ABSOLUTE RESISTANCE OF MERCURY. — In a recent number of *Wiedemann's Annalen*, F. Kohlrausch publishes a redetermination, which he has carried out with elaborate precautions, of the absolute resistance of mercury. The method employed was Weber's method of the damping of a magnet in a coil, with some slight modification of Dorn. The result arrived at is, that the resistance of a cubic centimetre of mercury at 0°C. is 94,060 centimetre seconds. In order to compare this with the B.A. unit, Mr. Glazebrook has compared one of the author's mercury standards with the B.A. unit in the Cavendish Laboratory, and finds, that, according to Kohlrausch's determination, one B.A. is equal to 0.9866 of an ohm. This would give a length of between 106.2 and 106.3 for the column of mercury of one square centimetre in section, having a resistance of one ohm.

ELECTRIC LOCOMOTIVES FOR MINES. — In this country the only applications of electricity to traction in mining, with which we are acquainted, is in Lykens, Penn. In this, current is conveyed to

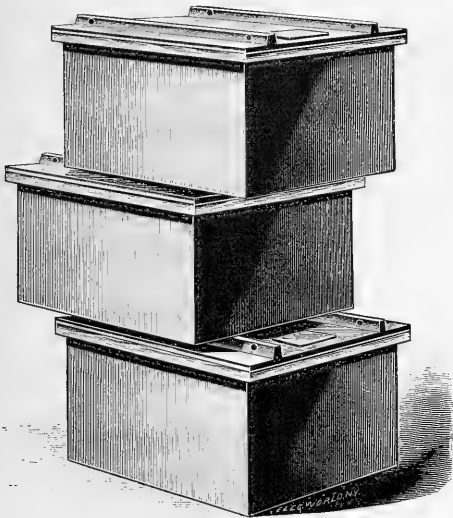

FIG. 2. — THE MACRÆON STORAGE-BATTERY.

lead, fastened at the top to the crossbar of a lead frame, while at the bottom they have a freedom of movement which prevents "buckling" when the strips expand on discharge. These positive plates are fixed to the metallic top of the box. When the cover is in place, the top of the cell is positive, and the bottom is negative, with an insulation between them. The closing of the cell avoids the occurrence of acid fumes, and the evaporation of the acid.

The following tables give some data as to the performance of the cells: —

Stationary or "Central Station" Type.

Size.	Normal Charging Current.	Normal Discharge Current.	External Dimensions.			Weight Complete in Pounds.	Normal Capacity in Amperé Hours.
			Length.	Width.	Height.		
A	6	1-8	11	5¾	4½	35	50
B	12	1-17	11	5¾	6¾	52	100
C	20	1-32	10½	10	6½	80	200

the motors through an overhead wire. In Europe there are several successful examples of electric tramways in mines, and lately Messrs. Immisch & Co. have built a new mine-locomotive from the designs of Mr. Reckenzaun. Storage-cells are employed for supplying current, and a single motor of four-horse power. The gearing is peculiar. On the armature-spindle is a small phosphor-bronze pinion. This gears into four steel pinions placed in the same plane, and 90° distant from each other. These pinions are bushed with gun-metal, and run on steel pins carried on a cast-iron disk. The disk revolves on a journal turned outside of the end of the motor-bearing. Outside of, but in the same plane with, these pinions, is fixed an annular casting of gun-metal, with teeth cut on the inside. The steel pinions gear into the ring, which forms a fulcrum on which they revolve when the motor-spindle turns. The power is transmitted from the cast-iron disk by a sprocket-pinion keyed to it on the inside next to the motor, and a steel chain connects this sprocket-pinion to a suitable wheel mounted on one of the axles, while the other axle is connected to this by coupling-rods. The storage-battery consists of forty-four modified Tatham cells, each box being 10 inches by 6½ inches, by 11 inches high. The boxes are lead-lined, and arranged in sections of three in wooden trays. Each box contains nineteen plates 7 inches by 4½ inches, by ⅜ of an inch thick, and has a capacity of 150 ampère hours, the weight being 53 pounds. The rate of discharge varies from 25 to 50 ampères, and sometimes, on starting, this increases to 65 ampères. Taking 40 ampères as the average rate, the weight of these cells for a discharge equivalent to one horse-power is nearly 500 pounds, and per horse-power-hour storage-capacity, 134 pounds. The Messrs. Immisch are now working on some improvements by which the capacity will be increased. This locomotive, on a grade of 1 in 70, would just move, with a load of twenty loaded cars equivalent to eleven tons. With fifteen cars, weighing eight tons and a half, the speed was three miles per hour, the current being 45 ampères at 100 volts pressure. On a grade of 1 in 40 the maximum load was eight cars, and on 1 in 25 it was six cars, the speed being a little over two miles an hour. On the level the locomotive could draw thirty cars, the current employed being 45 ampères.

FELLING TREES BY ELECTRICITY.—Hitherto machines for felling trees have been driven by steam-power, but this is sometimes inconvenient, especially in thick woods; and now the *London Times* reports that electric power has recently been adopted in the Galician forests. Usually in such machines the trunk is sawed, but in this case it is drilled. When the wood is of a soft nature, the drill has a sweeping motion, and cuts into the trunk by means of cutting edges on its sides. The drill is actuated by an electric motor mounted on a carriage, which is brought up close to the tree and shackled to it. The motor is capable of turning round its vertical axis; and the drill is geared to it in such a manner that it can turn through an arc of a circle and make a sweeping cut into the trunk. The first cut made, the drill is advanced a few inches, and another section of the wood removed in the same way, until the trunk is half severed. It is then clamped to keep the cut from closing, and the operation continued until it would be unsafe to go on. The remainder is finished by a hand-saw or an axe. The current is conveyed to the motor by insulated leads brought through the forest from a generator placed in some convenient site.

HEALTH MATTERS.

Public Inspection of Food.

THE following resolutions were offered by Dr. George Strawbridge at a recent meeting of the Philadelphia County Medical Society:—

“The Philadelphia County Medical Society begs to call the earnest attention of city councils and the Legislature of Pennsylvania to the pressing need of provision for the inspection of all meat and milk used as food, with a view of furnishing sound meat and milk to the people.

“The society would also urge the necessity of killing and destroying all animals afflicted with tuberculosis, and the owner should be indemnified by the State.

“The society also recommends that a committee of five be appointed by the president of the society, whose duty it shall be to represent the society with a view of obtaining further information, and to confer with other bodies acting in this matter.”

Dr. Strawbridge, in introducing his resolutions, said: “Statistics as reliable as can be obtained make the statement not too broad, that in Philadelphia, about the present time, there is from three to three and one-half per cent of tuberculed meat used, and from six to eight per cent of tuberculed milk. Here in Philadelphia to-day there is no inspection of any kind. The best the board of health could do was to obtain an appropriation of fifteen hundred dollars for the appointment of a milk-inspector, who will probably start to the stations to see how much water goes into the milk. Anybody can dump any kind of food in Philadelphia, and we must take it; but if we refuse to eat it, we are told that we are not good citizens. Meat ought to be inspected when alive, and also during the process of slaughtering. Unless you can inspect the animal alive, and also when the internal parts can be viewed, the inspection is useless. In the inspection of milk, the principal thing is to see the cows that give it, so that they are not diseased, and to inspect it at its place of delivery.”

The resolutions were adopted, and a committee was appointed consisting of Drs. Leffman, Huidekoper, Shakespeare, Osler, and Cleeman.

CHOLERA CONTAGION IN DRINKING-WATER.—F. G. McKean, chief engineer in the United States Navy, states that during ten days in 1885, nine hundred persons died of cholera on the island of Takashima in Japan, and that the disease often appears on the island. Suspicion was drawn to the drinking-water, which was brought from the mainland. During 1888 the use of this water for drinking-purposes was abandoned, and distilled water was used instead. Although cholera prevailed on the neighboring islands, Takashima was entirely exempt. This exemption may have been but a coincidence; still, it is more than probable, from our knowledge of this disease, that the purity of the drinking-water is to be credited with the immunity which the population of the island enjoyed. To be absolutely certain of this, will, however, require more continued observation.

NOTES AND NEWS.

IN the “Sixth Biennial Report of the State Board of Agriculture of Kansas,” Mr. E. B. Cowgill, in the report on the sorghum-sugar industry, says: “The season of 1888 has been looked upon as the one which should settle the question as to the financial success of the sorghum-sugar industry, and, fortunately for the incoming industry, the answer must be taken as an affirmative one. It is true that not all of the factories in Kansas are able to show balances of profit. The fact, however, that the favorable results obtained in 1887 at Fort Scott have been more than repeated at that place in 1888; that a factory at Topeka has demonstrated the practicability of the sugar industry at that place; and the further fact that Conway Springs and Douglass, in the face of adverse circumstances, have shown the industry to be independent of all patented processes and machinery,—will go far toward assuring all diligent inquirers of the success of the Northern sugar industry. Indeed, upon the most careful study of the subject, I have no hesitation in saying that the sorghum-sugar industry is now on such a footing as to invite the investment of capital, where such investment is placed under good business management, efficient, practical skill, and competent, scientific direction.”

—A recent invention of Messrs. Randall & Carter, for the preservation of freestone from the effects of weather, was exhibited by them at the Cannon Street Hotel, London, on Feb. 15, in the presence of a large number of architects and builders. Several specimens of well-known oolitic freestones, which had been treated by this process in such a manner as to make their surfaces quite hard enough to be polished, were shown. The process consists of treating the stone with a compound of milk of lime, acetic acid, and cane-sugar (or molasses), which, when applied, soaks into it for a depth of about half an inch, and produces a slight chemical change, materially hardening it. The stone may either be entirely im-

mersed in this solution, or the latter may be applied to its surface with a brush. The surface is then rubbed to a face with fine grit, and allowed to dry, after which it is subjected to a diffused dry heat of from 130° to 160° F. in an oven. When the stone to be treated is fixed in position, as in a building, it is stated that the compound may be applied with a brush, either with or without heat subsequently. Although it is admitted that by heating the stone its durability is greatly increased, the *London Builder* thinks it questionable whether this is practicable on a large scale after it is built up. But even supposing it were practicable, it is very doubtful whether the hardened surface would protect the stone for any great length of time. Experience has shown, that, where only a hardened coating has been formed, moisture soaks in, either through the cracks in the masonry or through portions of the surface of the stone itself, rendered vulnerable by the defective application of the preparation, whatever it may consist of. The moisture collects behind the hard coating, and produces a line of weakness, in consequence of which the thin crust flakes off. Moreover, it is wrong to suppose, that, because a lime solution hardens a stone, the latter thoroughly resists decay, as has often been suggested. The mere fact of the stone being hardened does not add much to its durability from a chemical point of view, unless the hardening material be acid-resisting. The only effect of the hardening is to render the stone less absorbent, and therefore slightly more durable, for a few years at most.

— Lord Wolseley, who is not often caught tripping in making hasty statements, writes as follows in the current number of the *Fortnightly Review*: "The battles of the future will be very different from even those of 1870. . . . One remarkable change will be the absence of nearly all that terrific noise which the discharge of five or six hundred field-guns, and the roar of musketry, caused in all great battles. . . . The sound of cannon will be slight, and will no longer indicate to distant troops where their comrades are engaged, or the point to which they should consequently march. Our sentries and advanced posts can no longer alarm the main body upon the approach of the enemy by the discharge of their rifles. The camp or bivouac will no longer be disturbed at night by the spluttering fire of picquets in contact with the enemy. Different arrangements for giving the alarm upon the approach of hostile columns will have to be resorted to. The main column on the march cannot in future be warned, by the shots of flanking parties, of the enemy's proximity, and a battle might possibly be raging within a few miles of it without that fact becoming at once apparent." *Nature* asks that some competent member of the "Scientific Corps" will kindly explain.

— The prefect of police in Paris has issued a new set of regulations with regard to the fire brigade service in theatres, which will, it is thought, reduce very much the risk of fire; so far, at least, as it can be reduced in the many theatres in Paris which have always been, and must remain, from the position they occupy, regular death-traps. A certain number of firemen are allotted to each theatre, who, under no pretence, are to be called out of the theatre, or to receive visits from friends or acquaintances. The chief of the detachment has the responsibility of seeing that all the apparatus for extinguishing a fire is in its allotted place and in proper order, and the commissary of police is to satisfy himself that this has been done before the theatre opens. During the representation the chief of the detachment must be constantly moving about to see that the men are at their posts, that no one is smoking in the corridors or carrying open lights, and that access to the reservoirs and fire-plugs is not hampered by placing any scenery or stage properties in the way. He is to examine the manometer, and, if he finds that there is a deficiency of pressure in the water-mains, he must inform the nearest post of the fact. In the event of an insignificant outbreak, recourse is to be had only to the apparatus within reach of the *foyer*; but, if the outbreak is of a more serious character, the nearest post is to be informed by telegraph. At the close of each representation the firemen are to make a round of the theatre, and see that the iron curtain is lowered, the buckets filled, and the folding doors closed, and, in the event of these not working smoothly, they must be repaired at once. The manager of the theatre is required implicitly to obey the orders of the district com-

missary of police, who, in the event of an outbreak of fire, assumes the sole command of the theatre until the arrival of the prefect of police or the chief officer of the fire brigade.

— *Nature* makes the following extract from a letter addressed by Mr. A. W. Tuer to a contemporary: "The melodious hum of skating was perhaps never heard to greater advantage than through the crisp air of a bitterly cold morning little more than a fortnight ago,—the first Sunday in the year. Almost as soon as Kensington Gardens were entered, one became conscious of a clearly defined musical sound coming from the direction of the Round Pond,—G as nearly as I could judge, but corrected to G sharp, when, half an hour later, I got to a piano. I had wished to compare the notes—probably lower—given forth by other and larger sheets of ice, but procrastination strangled an opportunity which perhaps others will take when it again offers. Comparing a sheet of ice to a taut string, and the countless skates to the hairs of a bow,—scientifically, a poor comparison enough,—the sound might be expected to have been like that produced by the scraping of a fiddle, but it exactly resembled the whistle of a distant locomotive."

— The following description of some of the most important features of the subsurface torpedo-boat lately submitted to the Navy Department by the Columbian Iron Works of Baltimore, and the uses for which it is intended, serve to clear up several points which might possibly have caused a misunderstanding as to the nature of the craft. The boat is cigar-shaped, and is capable of being operated under three different conditions: first, above the surface, that is, with nearly half of it above water; second, awash, that is, with only a few inches of the back exposed, together with the conning tower; third, completely submerged, that is, with nothing whatever appearing above the surface. In the last condition, which is the primary condition for torpedo warfare, the boat's means of offence is a horizontal tube directly in its axis, from which are discharged 8-inch projectiles either by pneumatic power or by powder. These projectiles are capable of giving several hundred feet range, and the gun and projectile are constructed on a principle first propounded by Lieut.-Commander Barber at the United States torpedo-station in 1873, but separately invented, and proved successful by Mr. Holland, the inventor of this boat. In lieu of this submarine gun, the boat will be fitted with any kind of locomotive torpedo that the Navy Department may desire to be fired from this or a similar tube. In addition to this tube in the axis of the boat, there is another 8-inch tube, fitted at an angle, for over-water fire at distances of 1,000 yards or thereabout. It is intended to use this tube for throwing dynamite shells, under circumstances where the boat cannot approach the enemy within torpedo range, or where it may be preferable not to try to do so. The boat has a double skin on the upper forward part, separated by about a foot of space; and this space is filled with water, which flows freely into it. Aft of this, and forward of the gun-room, is a vertical bulkhead of several inches of iron. When, therefore, she is lying awash, and using her upper pneumatic gun (which makes no smoke), she will be almost invisible to the enemy, and, if struck by machine-gun projectiles, she is almost certain to be uninjured.

— The wine-making industry in California is the subject of an interesting article by Edwards Roberts in the supplement to *Harper's Weekly* of March 9. The article is copiously illustrated.

— The Eiffel Tower has already attained a height of 280 metres, and in a month it will be completed by the turret and the electric lantern, which will give it its greatest height of 300 metres. The Paris correspondent of the *London Builder* says, "It is curious to notice to-day how inferior is the effect produced by this enormous piece of iron-work to the idea that people had of it in advance. Seen from the environs of Paris, it overpowers the city, and appears immense by the side of the large monuments, which are reduced to very small dimensions; but the nearer one approaches it, the less is one aware of its colossal proportions, and the eye hardly sees what relation can exist between the thin termination of the tower and the gigantic arches of its base. There is an optical illusion about it which will always weaken its general effect, and disappoint the hopes of the promoters of this useless attempt to astonish the eye by its giddy height."

SCIENCE:

A WEEKLY NEWSPAPER OF ALL THE ARTS AND SCIENCES.

PUBLISHED BY

N. D. C. HODGES,

47 LAFAYETTE PLACE, NEW YORK.

Subscriptions.—United States and Canada..... \$3.50 a year.
 Great Britain and Europe..... 4.50 a year.
 Science Club-rates for the United States and Canada (in one remittance):

1	subscription 1 year	\$ 3.50
2	" " 1 year	6.00
3	" " 1 year.....	8.00
4	" " 1 year.....	10.00

Communications will be welcomed from any quarter. Rejected manuscripts will be returned to the authors only when the requisite amount of postage accompanies the manuscript. Whatever is intended for insertion must be authenticated by the name and address of the writer; not necessarily for publication, but as a guaranty of good faith. We do not hold ourselves responsible for any view or opinions expressed in the communications of our correspondents.

VOL. XIII. NEW YORK, MARCH 15, 1889. No. 319.

CONTENTS:

JOHN ERICSSON..... 189	THE RESOURCES OF THE NYASSA REGION, EAST COAST OF AFRICA 200
THE DENIO FIRE-ALARM..... 191	BOOK-REVIEWS.
AN IMPROVED ELECTRIC SYSTEM..... 192	Occasional Addresses on Educational Subjects..... 201
GRAY'S TORSIONAL TESTING-MACHINE..... 194	A Treatise on Hydraulics..... 201
THE MACROEON SECONDARY BATTERY..... 194	A General Formula for the Uniform Flow of Water in Rivers and other Channels..... 202
ELECTRICAL NEWS.	AMONG THE PUBLISHERS..... 202
The Velocity of Light..... 195	LETTERS TO THE EDITOR.
Absolute Resistance of Mercury..... 195	An Acoustic Mill <i>A. E. Dolbear</i> 204
Electric Locomotives for Mines..... 195	Note on the Robinson Anemometer Constant <i>Wm. Ferrel</i> 204
Felling Trees by Electricity..... 196	The Soaring of Birds <i>L. M. Hoskins</i> 205
HEALTH MATTERS.	Shall We Teach Geology? <i>Alexander Winchell</i> 205
Public Inspection of Food..... 196	To keep Water-Mounts Moist <i>E. B. Knerr</i> 205
Cholera Contagion in Drinking-Water..... 196	The Wind-Pressure Constant <i>Wm. Ferrel</i> 205
NOTES AND NEWS..... 196	
EDITORIAL..... 193	
John Ericsson.	
PUBLIC HEALTH A PUBLIC DUTY..... 198	

JOHN ERICSSON was a man with the best of brain-power, with confidence in himself, who lived at a time when the world was ripe for what he could best do. He was essentially a great mechanical engineer. And not only was he fortunate in the age in which he lived, but he was wise in his choice of a place of residence. The fate of mechanical inventions is like that of the seed in the parable: the invention must fall on a proper soil, and be nurtured by favorable circumstances of time and place, in order to bloom into success. Thus Ericsson was early led from his home in Sweden to England, where he found a congenial environment till the conservatism of the English Admiralty drove him to this country. He was a man accustomed to carry through to useful perfection any scheme which commended itself to his mind; and, having confidence in himself, he found criticism difficult to endure. He knew he was right in his propeller for steam-vessels, and quickly left the country which refused to adopt it for America, where within two years the new device was in use on forty-two vessels. He knew he was right in his "Monitor," and was mortified and indignant at the hesitation of the American naval board in giving him a contract for building the first of this class of war-vessels. His work in each of these cases was not simply the devising of a form of propelling apparatus which would be better than the old side-wheel, or of a form of ironclad which was the best there was at the

time; but every mechanical detail of the "Princeton" and of the "Monitor" received some improvement at his hands.

Such was the man, and such was his work. He had the perseverance, the capacity to appreciate the importance of details, and the confidence in himself, which lead to success. And what was his reward? Doubtless he received considerable payments for much of what he did; but in the case of the "Princeton" it is said the government is still his debtor, and in that of the "Monitor" he received only the amount due him on his contract. As an inventor who supplied the government with an all-important engine of war, he received not a cent. Nor would he listen to the suggestion frequently urged on him by congressmen and others, that Congress should be asked to recognize his claim, and to provide for it. The Legislature of New York passed a resolution, thanking him for his services to the country, which he insisted on freely giving; and these resolutions he highly prized. Ericsson is said not to have cared for money, and this would certainly seem to be true.

The respect shown at his funeral was such as is seldom seen at that of any private citizen. The streets in the neighborhood of his late residence were crowded from the early morning hours with thousands, who for four hours passed through the house to pay homage to the departed genius. New York is a place full of human beings,—so full that each pays little or no heed to his neighbor; yet the great respect for this man of science and of action was shown in the number and character of those who followed his remains to their resting-place, in the uncovered heads as they were borne along the busy streets, and in the impossibility of admitting to Trinity all that wished. Ericsson was a man who could have endeared many to him, but he had a strong sense of duty to his work, which induced him to make few friends. This final homage of the unmindful crowds of the great city was to his genius well applied.

PUBLIC HEALTH A PUBLIC DUTY.

THE address of President Charles N. Hewitt, at the sixteenth annual meeting of the American Public Health Association, was full of suggestion, and contained many valuable propositions. It was entitled "Public Health a Public Duty," and dealt with the organization, powers, and relations of local, State, and National boards of health. In reviewing the work of the association, and the progress made in sanitary science during recent years, he said:—

"As secretary of one of the oldest of the State boards [Minnesota], I had the honor of an election as an original member of this body, and have known its history since. In my own State, beside, I have been missionary at large, and served as the organizer and counsellor of many a local board, and as sanitary inspector and health-officer as well. I have seen our organizations grow from two feeble boards with ill-defined powers, in 1872, to over fourteen hundred, united under a common code of law, with largely increased powers, duties, and funds. There is not to-day in Minnesota a community, however small, without such a board in direct communication with the State board.

"The State boards of health have increased from three in 1873, to thirty-one in 1888. Largely through their efforts, popular knowledge and confidence have grown from the tentative methods of the past to the demand for, and more liberal support of, sanitary organization and positive work. More and better legislation, great sanitary engineering works, and a bountiful crop of private enterprises in the same direction, are among the evidences that our field is widening and our responsibilities increasing. We have seen the early examples of efficient State executive organization become a living force in many more of the States and Canada. Various departments of modern science are our willing helpers. Microbiology has opened up great stores of discovery, and awakened great hopes, which we trust may not fail. We have seen the be-

ginnings of international co-operation for the crushing-out of cholera, yellow-fever, and other epidemics, which must in the near future become a beneficent reality, taking its place with arbitration, in international disputes, as the most valuable victories in our century.

"The first essential of any sanitary authority," Dr. Hewitt says, "is executive power, and its systematic use in the regular and scrupulous performance of every-day duty, as defined in the law and suggested by every-day experience. This almost self-evident proposition is constantly neglected in legislation for organization, and is very frequently violated by boards of health, who seem to favor the popular idea that an exceptional occasion is necessary to the highest exercise of their power, and infectious diseases of the classical type are their selection, with a proper admixture of panic. Panic is no advantage any longer, if it ever was, as a help to sanitary organization and work. Infectious diseases are not the leading causes of our sickness and mortality. It is only in the exceptional severity of plagues like yellow-fever, as it has prevailed in Florida, for example, that infectious disease counts the most victims in the sickness or death roll. That epidemics prevail at all, in our time and country, is somebody's fault: for, if there is one thing more than another that modern hygiene ought to be able to do, it is to forefend their attack, or control them if they effect a lodgement; and boards of health and health-officers have to learn that the most public and pronounced activity, after the invasion of infectious disease, is no substitute for the quiet, unobtrusive work which, in daily faithfulness, would have detected the first case, and controlled its spread. Another pressing need is a better classification of causes of death, for sanitary purposes, to which should be added causes of sickness and of permanent ill health from disease. At present our professional nomenclature is as vague sometimes as the popular one. Cholera-infantum and heart-disease are little more accurate than 'too weak to live,' a common popular cause of death under one year. The general divisions of the English registrar-general's tables are the best known, but some of the subdivisions are not satisfactory. Isolation has become so important and efficient an aid in the control of many diseases, that it is time to devise some changes in our customary methods which shall insure more thoroughness, with the least interference with the liberty of the family. It is a serious matter to restrain the bread-winning power of a laboring man or of his self-supporting children; and it is a still more serious matter to shut up a suspected family, sick and well, in a small house, when the removal of perhaps a single patient might save the rest, or some of them. The isolation home, under various names, is the ideal method of us all; but, if we had one always available, people must be educated to its use. We need it most for diphtheria and scarlatina. Another essential is an apparatus, not too expensive or elaborate, or too heavy for easy movement on wheels, for disinfecting clothing, bedding, and the like, by steam. One to which steam could be supplied by the boiler of a thrasher-engine would serve our country districts, and the same could be used where steam-boilers are available elsewhere. It could be taken to the infected house, charged, closed, and moved to the nearest available boiler, connected, disinfected, and discharged of its contents, with no danger, and at trifling expense. Still another need in this connection is a ready way of disinfecting the sick-room while occupied. Its essential feature should be the removal of the infected air and dust, disinfecting both as they escape, and the introduction of fresh air, so that quantity, temperature, moisture, and movement may be as required by the sick, but all to be done with the most complete protection of the well. The means must be easy, comparatively inexpensive, and available in the average houses of the laboring population. The stove, stove-pipe, or chimney, affords the available means in such houses in cold weather. In warm weather the open fire, gas, or kerosene, might serve to provide the means for exhausting the foul air and introducing that of the open in its place. Add to the simplest form of apparatus (the open fire or stove-pipe exhaust), cleanliness, fresh air, sunlight, thorough inunction, and boiling water for infected clothing of the sick and attendants, and you have a method almost everywhere practicable, which will reduce the danger from such diseases to the minimum, and the mortality as well.

"The very large mortality from non-infectious disease, under

five years of age, is, in the light of our present knowledge, no longer tolerable; and boards of health should move now, and positively, for its material reduction. By the last census this mortality was 43.7 per 1,000 of living population for the whole country, while in thirty-one registration cities it was 88.4 per 1,000. The mortality under five years to total of all ages was given as 39.8. The deaths under one year were, for the whole population, 120.9 in 1,000 living, while for the cities it was 267.5. This does not tell the whole story, as the statistics are estimated to fall from 15 to 30 per cent below the facts. We have no means of accurately estimating the sickness rate which accompanies this mortality, but may assume that it is enormous.

"Another subject of increasing importance, and which ought to receive the immediate attention of the State boards, is the sanitary relation of certain diseases of animals as communicable to man, notably tuberculosis, trichinosis, and glanders; and the increasing possibility that diphtheria and scarlatina may belong to the same class. The relations of the diseases of the cow to the influence of milk as food are attracting wide-spread attention, and, as affecting a very important infant food, deserve an attentive study with reference to sanitary control. On this subject, popular and certain professional opinion has, as usual, gone to extremes. From the use and even advocacy of distillery-milk, some have come to refuse the purest supply except after boiling, and their foolishness has been an acceptable and pecuniary advantage to the manufacturers of the proposed 'substitutes for cow's milk' which fill our markets and are tried on our children. The importance of the subject has resulted in making the control of infectious diseases of domestic animals one of the duties of the State and local boards of health, as in Minnesota, where the experiment has proven eminently successful and satisfactory.

"For the Nation and the States, the most urgent lesson is organization and efficient co-operation: for this last experience [of the epidemic of yellow-fever in Florida] but adds another to the accumulated evidence of the near past, that no State or province on this continent can afford to be any longer without a board of health officered by experienced men, who have the confidence of the people and governments they serve; supplied with unquestioned legal authority and sufficient money; and provided with every recognized means for dealing directly, and to the best advantage, with any disease of men or domestic animals threatening, or actually invading, the State. It must also, and for the same reason, have authority and funds to act with similar authorities of other States, in mutual co-operation, for State and national defence. It will not do to forget the established fact, that epidemics are now to be looked upon as evidences of the failure of public health, in organization or administration. That they occur, or spread, is presumptive evidence, when properly qualified authorities exist, that they neglected to take the needed measures, or were unable to take them. I see no escape from this conclusion, except it be shown, in any case, that prevention or control was beyond the resources of our art.

"A central State authority, organized and equipped as proposed, will find itself unable to do efficient preventive or restrictive work without thoroughly organized local sanitary authorities in every township, village, and city; and, further, each local board should have the same powers, and proportionate means, as the State board, in the locality it serves. Enforcing the common law, and independent in all purely local administration, the local authorities should be a unit for common purposes, under the State board, of which the control of infectious diseases is a conceded example.

"There are now in the United States thirty-one State boards of health. The first was organized in 1869, and others as well, before any attempt at national organization was made. Some of these boards are fully equipped with legal powers and funds for the work we have found laid out for them. The rest, with varying degrees of speed, are coming on to the higher level necessary for efficiency, and all are growing in usefulness and experience.

"State boards of health are established and recognized forces to-day; and any national organization attempted must, to be successful, be a development from them in form and function, for the purpose of carrying over to the nation, as a whole, the sanitary succor which the best of the State boards afford to the populations

they serve. A national board of health must first supply the national need proven to exist, by the conjoined efforts of the efficiently organized State boards, and fill up the full measure of that work within the national boundaries. So established, in the same dignified relation to the National Government that such State boards bear to the governments of the several States, it is prepared to perform the twofold duty, beyond our borders, which results from our present knowledge of the modes of approach and attack of infectious diseases. It must protect the nation, first, by a thorough knowledge of the character, location, and movements of such diseases abroad; second, by preventing, by the best-known methods, the shipping to this country of infected persons, animals, or things; third, by insisting upon competent sanitary service on board ship, with the best facilities for preventing, controlling, and crushing out any form of infection discovered on the passage out; fourth, by providing that the sanitary authority at the port of entry shall be fully informed of what is known of the sanitary history of the ship and her lading, up to the date of arrival, with later telegraphic report from the American consul and health-officer at the port of departure, if necessary.

"It is a fact that to-day, if it will, our government may learn all that is here proposed, by locating competent health-officers at the foreign shipping ports, whence our greatest danger comes, and might keep the seaboard quarantine authorities fully posted in these important particulars. As to those local authorities, it is time to call a halt in the criticism of their work till all sides in the controversy can be heard; or, better still, till health-officers of inland States can visit and see for themselves. Until the State boards agree in organization and powers, and in proper relations to local boards, the re-organization of the National Health Service upon a sufficient and permanent basis will be difficult, if not impossible."

THE RESOURCES OF THE NYASSA REGION, EAST COAST OF AFRICA.

FOR a number of years two English companies have been carrying on a profitable trade in the Nyassa and Tanganyika region, which, however, has recently suffered a severe check by the uprising of the Arabs against European influence. In a recent number of the *Journal of the Manchester Geographical Society*, Messrs. James Stevenson and E. O'Neill, consul of this district, give some interesting reports on the state of affairs and on the resources of this country, from which, and from some observations of other travellers, we take the following notes. Mr. Stevenson's paper is accompanied by an interesting sketch-map, reproduced here, showing the extent of the ravages of the slave-trade and the caravan routes in this region. The map will be of interest as supplementing the general map of Africa showing the extent of the slave-trade, published in *Science* of Dec. 28, 1888.

The produce of the Nyassa region, and the methods of trading, are well described by Mr. O'Neill. First in importance among the objects of trade is ivory. To this most valuable of all exports, — putting aside for the present any possible supply of minerals, — trade must chiefly look for an immediate return on its capital. Perhaps there are no better elephant-hunting fields in Central Africa than the great marshes of the Shire River and on the west coast of Lake Nyassa. The supply from these might be largely increased, to the benefit of trade, the country, and the people generally. The Arab slave-dealer is the chief collector of ivory in this country, with the tusks of which he loads his slaves, obtaining thereby cheap and profitable carriage to the coast. The British trader upon the Nyassa obtains but a fraction of the whole amount collected, — just so much as the Arab chooses to part with to enable himself to renew his supply of barter-goods, and to resume his collection in the interior. While the operations of the British trader on the Nyassa are confined to his station on the shores of the lake, he plays the dignified rôle of a storekeeper to Arab traders, where they may renew their store, and be relieved of a journey to the coast.

Much has been said of the check given to the slave-trade by the taking-up of the ivory on the Nyassa from the hands of the Arab collector, thus obviating the necessity for slave-carriage to the

coast. But it is certain that a very slight blow is struck by this means at the slave-trade. Little good will really be effected until the collection in the interior is also carried out by the whites, and the Arab trader is undersold, and thus peacefully ousted from the collecting-field. The British trader has every advantage on his side. Water-carriage should place his goods upon the Nyassa cheaper than they can be carried there overland by the Arabs, who have also to contend with the high percentage exacted from them for advances by the Indian trader of Zanzibar or Mozambique.

Next in importance to ivory must be placed India-rubber, in which the country west of Nyassa, stretching towards Lake Bangweolo, is undeniably rich; but comparatively little is collected, as the natives know little of the value of the plant, and have never been taught to collect it. Its export might probably be indefinitely increased by the same means which would help to extend the ivory-trade.

There are many other products indigenous to the country, but few of those known are able to bear the present cost of carriage to

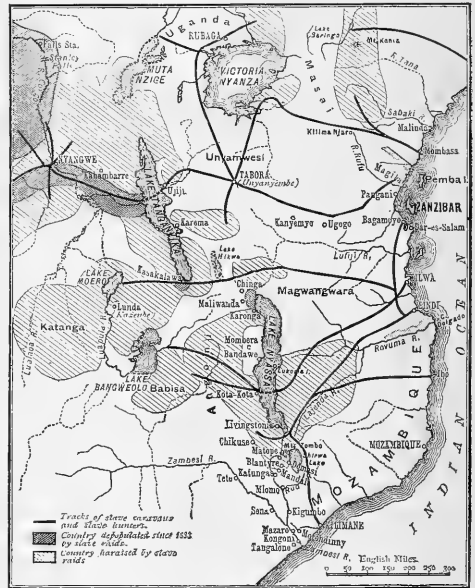

markets. When the country comes to be better known, the number of more valuable products will be undoubtedly increased. Consul O'Neill says in regard to this point: "How completely valuable products may remain hidden until some chance brings them to light, I can instance by the case of *Strophantus Kombe*, of which some specimens were sent by me to the Foreign Office in 1881. A demand for it as a drug for heart-disease shortly after sprung up, and its existence in this country having been thus proved, I was able to start its collection in the Shire and Nyassa districts and in the Gaza country. The first consignment home proved to be so valuable to the collectors, that soon a rush was made to collect it, and the natives were quickly taught to bring down the pods in large loads. In the same manner we may hope other valuable products will come to light, and more profitable exports found than the oil-seeds which now form the staple articles of production on the coast and the lower Zambezi and Shire Rivers."

To estimate justly the probable development of this region, it must be remembered how slow and gradual has been the development of trade on the African coast. When the British Indian traders, to whom, a little more than a century ago, the Portuguese viceroy of India granted a monopoly of the trade of East Africa, arrived on

the coast, trade was precisely in the condition we find it now in the interior. The natives knew nothing of the collection of valuable products, — knew not, indeed, of their existence until shown. Now, on the coast, and for a hundred and two hundred miles inland, they have learned the demands of trade, and a regular collection is made by them of rubber, calumba, orchilla, and copal.

So far, we have spoken only of the export of produce indigenous to the country. When Europeans, however, begin to settle in it, — and in a small way this settlement has already begun, — fresh sources of wealth are opened up; and other products, for which the climate and soil are found favorable, are cultivated, and their export forms a valuable adjunct to that of the natural products of the country. Coffee and sugar have already been raised with success; and wheat, tea, and cinchona are all undergoing trial. The coffee and sugar consumed at the mission-stations are mostly home or Nyassa grown, and very good in flavor and strength. Recently Angora goats have been introduced for the production of mohair.

The climate of this region, which is from three thousand to five thousand feet above sea-level, is considered comparatively healthy, and, although it is not probable that it will ever become the home of a numerous white population, is well adapted to the establishment of plantations, worked by natives and managed by whites. The lake itself, which is only sixteen hundred feet above sea-level, has not as favorable a climate as have the slopes of the highlands.

The most important feature of the Nyassa region is its easy access. The uplands surrounding the Nyassa are divided by the only navigable waterway to the coast of Africa, and this alone marks it out as one of the first districts of East Central Africa for European occupation. There is nothing like it farther south, where European settlers are steadily advancing. To be able to step into a river-steamer at a seaport, as may be done now at the mouth of the Zambezi, and be carried up in five or six days to the foot of the Shire highlands, within a day's walk of the first settlements, is an immense step already gained. The new river-steamer plying on the Shire and Zambezi is a stern-wheeler, intended to carry seventy-five tons on a moderate draught. There is also a steamer of considerable size in course of construction on Lake Nyassa.

The trading company of Lake Nyassa, and the missions of that region, — the Free Church of Scotland Missions, which occupy the west coast of the lake; the Universities' Mission, which occupies the east coast of the lake, — have expended altogether some \$750,000 on this region. In pursuance of these objects, a survey was made of a road for about forty-six miles through the rough country of Lake Nyassa, towards Lake Tanganyika, which is reached from the terminal point of that road through an easy country. The road was made by native labor, and the traffic on it was at first worked by parties hired by the company from the Nkonde, Wanda, and Mambwe tribes, with all of whom the company made treaties by which its authority was recognized over these districts. At present its management has, however, slipped into the hands of the Arabs, who purchase goods at the Nyassa terminus, and convey them by their own people, often slaves, to Lake Tanganyika, the European staff being too limited in numbers to superintend all the stations required.

The steady advance of commerce in this region is seriously threatened by the progress of the Arabs, who have recently also invaded this country. For ninety miles along the south coast of Lake Tanganyika almost the whole population has been swept away or scattered, and in the adjoining fertile country of Ufipa the Arabs are now in great force.

During the last year, letters from the mission-stations expressed apprehensions, on account of the presence near Lake Nyassa of an Arab trader who had formerly made slave-raids in the Tanganyika region. These traders have congregated in numbers at the Nyassa end of the road, on account of the small steamer of the African Lakes Company having been for some time detained on account of disturbances. At various points besides the north end of the lake, the Arab invaders are ready, and have added to their old station at Kota-Kota one near Bandawe Mission; and besides Losewa and Makanjiva's, they have been aggressive near Blantyre.

All reports make it an undoubted fact that the question of commercial progress in Central Africa will solely depend upon the out-

come of the present struggle between Arabs and Europeans. The raids of the former are extending continually westward; and, wherever they have invaded a country, nothing but ruin remains. It appears doubtful whether the joint action of the European nations will succeed in breaking the power of the Arabs in the inaccessible fastnesses of Central Africa. It seems that the only means of success would be an absolute stoppage of the introduction of firearms, which would deprive the Arabs of a great part of their superiority over the native states.

BOOK-REVIEWS.

Occasional Addresses on Educational Subjects. By S. S. LAURIE. Cambridge, Eng., University Pr. 12°. (New York, Macmillan, \$1.25.)

PROFESSOR LAURIE, well known as lecturer on educational history and methods in the University of Edinburgh, here gives us another volume on his favorite themes. In it he touches on a great variety of educational topics, and handles most of them with ability as well as enthusiasm. Professor Laurie believes in the importance of studying educational theories and methods, and holds that no teacher is properly equipped for his work who has not been through a course of such study; and he gives excellent arguments and illustrations in support of this view. In regard to both subjects of study and methods of teaching, he is at issue with some enthusiasts of the present day, and especially with the advocates of manual training and competitive examinations. With respect to the latter, he takes the ground that competition in school is in its nature an evil, since it fosters "the desire to beat others, and exalt self over others," which he justly affirms to be anti-social. Moreover, he maintains that educational competition does not secure the best service to society. The whole lecture on this subject ought to be carefully read by American educators. He is opposed to free schools, and presents the well-worn arguments against them, but without adding any thing new.

With regard to subjects of study, Professor Laurie is a strong advocate of the humanities. He believes in technical schools in their proper place, but speaks slightly of manual training in ordinary schools, remarking, that, "if the spirit of man can be educated through his fingers, it is a pity that Plato and Shakspeare ever wrote, and Christ ever taught." The end of education, in his view, is not to make good workmen, but good men; and his school curriculum is arranged accordingly. He would abandon Greek as a required study, because of the importance of French and German, and would base the course of study in secondary schools on English and Latin. He has a strong and, we think, sound sense of the educational importance of literature, especially in its moral and æsthetic aspects; and he would also devote considerable time to national history and politics. Of the physical sciences he would teach only geography, which seems a very narrow view; though it must be added that he would have geography taught in a very wide and liberal spirit. In mathematics he would teach only the elementary branches; and in French and German, as much as there is time for. This programme is sure to provoke criticism, from the scientists at least; but Professor Laurie is evidently not averse to controversy. His whole book is very suggestive, and we trust will not be overlooked by any one interested in education.

A Treatise on Hydraulics. By MANSFIELD MERRIMAN. New York, Wiley. 8°. \$3.50.

This volume is intended mainly for the use of students in technical schools, and consequently the subject has been treated, and the material selected and arranged, with a view to meet the requirements of such students. The author, who is professor of civil engineering in Lehigh University, is gifted with a perspicuous and pleasing style, and has produced a book which will without doubt prove an acceptable text-book upon the subject. A brief interesting chapter is devoted to the units of measure, physical properties of water, atmospheric pressure, gravity, and computations. A few hints on methods of study, appended to this chapter, would be of service to students in any department of science. Then follow in regular order chapters on hydrostatics, theoretical hydraulics, and the flow of water through orifices, over weirs and in

tubes, pipes, canals, and rivers. The measurement of water-power, the dynamic pressure of flowing water, hydraulic motors, and naval hydro-mechanics are treated in separate chapters, the latter subjects being given less space than their importance would seem to warrant. The book is amply illustrated.

A General Formula for the Uniform Flow of Water in Rivers and other Channels. By E. GANGUILLET and W. R. KUTTER. Tr., with additions, by Rudolph Hering and John C. Trautwine, Jun. New York, Wiley; London, E. and F. N. Spon. 8°. \$4.

To all engaged in the study of hydraulic problems, as well as to engineers who deal with the flow of water, this book will be of great service. It is the first published translation of the authors' chief work on the subject; though unauthorized translations from articles in German periodicals on this subject, by the same authors, were published in London several years ago. The first part of the work is devoted mainly to historical matter, and to a review of present knowledge of the laws governing the flow of water. A treatise on the new formula, showing its close agreement with a large number of experimental results obtained under differing conditions, makes up the second part. A supplement contains a more direct method of deriving the formula, for the benefit of those who desire mathematical brevity. A second general formula is also sketched, though not made prominent, as the first one is considered preferable.

The translators call attention to the fact that the authors have been erroneously regarded as holding their formula to be scientifically perfect, and covering both possible and impossible conditions of flow. They disclaim for them any such intention, insisting, that, as the formula is purely and essentially empirical, it must not be expected to apply to cases beyond the range of the data from which it has been derived. Its application is limited to cases where the slope of the water-surface can be ascertained with a degree of accuracy sufficient for the given case.

Nine appendices and five tables for practical use, which form part of the volume, contain much additional matter of value to those interested in the subject. In Appendices I. to IV. are given extracts from the works of Mr. Kutter upon the formula. Appendix V. contains directions for constructing the diagram used for a graphical solution of the formula. Appendix VI. is devoted to Kutter's modification of Bazin's general formula, useful for special purposes because of its simplicity. In Appendix VII. are given a number of formulæ and data concerning the relation between the mean and surface velocities in streams; the views of a number of investigators on velocities beyond which a scouring of the bed takes place in channels formed of different materials, are given in Appendix VIII.; and an account of Harlacher's method of ascertaining the discharge of rivers, in Appendix IX.

In Table I. are collected the hydraulic elements of over 1,200 gaugings, made in 300 different channels and pipes, under varying conditions of mean hydraulic depth and slope. In the original work the corresponding table is confined to 81 gaugings; so that this table is virtually the work of the translators, who believe it to be the most complete and comprehensive one yet published. The other tables contain the computed values of different elements of the formula, and the conversion of units of measure. An immense amount of labor has been bestowed upon this work by translators as well as authors.

AMONG THE PUBLISHERS.

THE delay in the publication of Sir Monier Williams's book on Buddhism has been caused by difficulties which have arisen in connection with the illustrations. A certain number of copies will be in Mr. Murray's hands at once. The work will be published in America by Macmillan & Co.

— Lee & Shepard have in press Samuel Adams Drake's "Decisive Events in American History, Burgoyne's Invasion of 1777, with an Outline Sketch of the American Invasion of Canada, 1775-76." It will be an admirable historic narrative, intended to be used as a text-book, or as a supplementary reader in schools, as well as for general reading. A valuable book, arranged especially for

young people, yet by no means unsuited to any time of life, entitled "Every-Day Business: Notes on its Practical Details," by M. S. Emery, will be published soon by this house. It gives careful instruction regarding many matters closely connected with business transactions. The book will be a valuable companion for young people, and its pages will contain instructions on business subjects, being designed for ready reference, and also as a text-book for use in schools.

— Macmillan & Co. will publish shortly "Natural Inheritance," by Francis Galton; a second series of Sir John Lubbock's "Pleasures of Life;" and A. R. Wallace's work on Darwinism.

— Harper & Brothers will publish this month the second volume of W. P. Frith's "Autobiography and Reminiscences," and a new and revised edition of the "Manual of Historical Literature," by President C. K. Adams of Cornell.

— Wolcott & West, Syracuse, N.Y., will shortly publish "Theories of Knowledge," by Rev. W. D. Wilson, D.D., Professor Emeritus in Cornell University.

— D. C. Heath & Co. have just ready, in their series of Guides for Science Teaching, "Hints for Teachers of Physiology," by Dr. Henry P. Bowditch of the Harvard Medical School. It will show how a teacher may supplement his text-book instruction by simple observations and by experiments on living bodies or on organic material.

— Dodd, Mead, & Co. have in preparation the letters and diaries of Emin Pacha, which, besides containing matter of interest as biography, relate largely to the author's scientific investigations. The volume has for an introduction a biographical sketch of Emin, with two portraits, one of them recent. They have also in press Bayard Tuckerman's biography of Lafayette, to be issued in two volumes.

— T. Y. Crowell & Co., in connection with the announcement of a cheaper cloth and a paper edition of Tolstoi's great work, "Anna Karénina," translated by Nathan Haskell Dole, state that Mr. Dole's translations have been received with great favor by the Tolstoi family. In a recent letter to Mr. Dole, the Countess Tatiana Lyovna Tolstoi says, "My father has read your translations, and is much pleased with them. They are to his mind very carefully and accurately done."

— Ulric Blickensderfer, Chicago, Ill., has just issued "Blackstone's Elements of Law, etc.," with analytical charts, tables, and legal definitions, arranged and displayed by a systematic and attractive method. Mr. Blickensderfer is an attorney-at-law, and claims that these charts will be found time-saving helps to his colleagues. Sample copies may be had on application. He also has published a chart of the "Historical and Genealogical Descent of the Crown of England," which by an ingenious arrangement of types brings the history of England on one side of a sheet of paper six inches wide and eighteen inches long, which folds up like an ordinary legal document. The succession covers from A.D. 827 to the ascent of Queen Victoria in 1837.

— The article on "Climbing Mount St. Elias," to appear in *Scribner's* for April, is the work of an American member of the Alpine Club, Mr. William Williams, who, with two English fellow-members, succeeded, during the summer of 1888, in reaching the highest point ever attained on that mountain, — about 11,400 feet. Charles Francis Adams, president of the Union Pacific, will contribute a railroad article to the number, on the "Prevention of Strikes." He proposes a plan which, if carried out, would be almost a revolution in the relations of railroad employers and employees. William H. Rideing, who made a careful inspection of the great Clyde ship-yards during the past summer, will give a description of them, showing the various stages in "The Building of an Ocean Greyhound."

— Ticknor & Co.'s March books include "Dragon's Teeth," translated from the Portuguese of Eça de Queiroz, by Mrs. Mary J. Serrano; and in their Paper Series, "Forced Acquaintances" (No. 53), by Edith Robinson, and "Under Green Apple Boughs" (No. 54), by Helen Campbell.

— An important undertaking is promised by the Leonard Scott Publication Company, in the American edition of the *Nineteenth Century* for March, in the shape of an American supplement containing a series of papers by some of the foremost of our educators on the relation of examinations to education. This subject has attracted considerable attention in England of late, having been started by the "Signed Protest" in the November *Nineteenth Century*. The present papers, presenting the subject from an American standpoint, will be by ex-President McCosh of Princeton, Presidents Adams of Cornell, Angell of the University of Michigan, Carter of Williams, Eaton of Marietta, Gilman of Johns Hopkins, Magill of Swarthmore, Pepper of Colby, Rhoades of Bryn Mawr, and Sharpless of Haverford; Chancellors John Hall of the University of the City of New York, and Sims of Syracuse; Professors Cook of the University of California, Harper of Yale, Harris of Concord, Hunt of Princeton, Rogers of Haverford, and David Swing of Chicago; Rev. Dr. Crosby, Hamilton W. Mabie, Esq., and Barr Ferree, Esq., of New York. Dr. William H. Burnham will also contribute, and Professor Thompson of the University of Pennsylvania. The symposium promises to form a most important contribution to the discussion of a very difficult question of educational methods. The March number of the *Nineteenth Century*, in addition to the papers on education and examination in the American supplement, will contain an article by Mrs. Humphry Ward, the author of "Robert Elsmere," on the new reformation as viewed from her own standpoint. Professor Huxley writes on "The Value of a Witness to the Miraculous;" and the review contains criticisms on his paper on agnosticism in the February number, by the Rev. Dr. Wall, principal of King's College, and Dr. Hagee, bishop of Peterborough.

— The *Popular Science Monthly* for April will contain a scientific explanation of the power to insnare the human mind possessed by the leading delusion of the present day. The article is by Professor Joseph Jastrow, and is entitled "The Psychology of Spiritualism." It contains accounts of the manifestations by the Fox sisters, Dr. Slade, Englington, and other mediums, all of which have been proved to be "gross intentional fraud throughout." Professor Huxley has written a racy reply to certain criticisms of agnosticism made at the Church Congress of 1888, and to a recent deliverance by Frederic Harrison, who attempts to prophesy on this subject. The article contains an account of how the name "agnostic" originated, and explains why agnosticism, as Professor

Huxley conceives it, cannot have a creed. It will also be published in the April *Popular Science Monthly*, as will an article on "The Chemical Elements," by Professor Josiah P. Cooke of Harvard, telling the story of the changing beliefs about what substances are made of, from the time when earth, water, air, and fire were thought to be the elements of all things, down to the present day, with its list of over seventy simple substances, and when the idea is gaining ground that perhaps there is only one kind of matter, after all.

— The paper in the *Political Science Quarterly* for March will attract most attention is that by Mr. H. O. Arnold-Foster, on "Irish Secession." It gives what is probably the best presentation of the Unionist argument that has appeared in this country, and should be carefully read by every one desirous of understanding the question at issue. The author takes up the home-rule arguments one by one, and gives a conclusive answer to some, at least, of them; while at the same time he presents very forcible considerations to show that an Irish parliament is equally undesirable for England and for Ireland. Another article of interest is that by A. Gauvain, on "The Crisis in France." M. Gauvain is deeply impressed with the low character of French political life, with the feebleness of the senate and the fickleness of the Chamber of Deputies, and with the instability of the administration; and he evidently views the future with some alarm. He affirms, as other observers have done, that there is no statesman of ability in the country, and that the republicans are drifting towards radicalism. Meanwhile the monarchists are gathering strength, and, with the aid of the Boulangists, stand a good chance of carrying the coming elections. The *Quarterly* has still another article on foreign affairs, that by Professor Gustav Cohn, on "Income and Property Taxes in Switzerland." Injustice has often been done in all countries to the poorer classes by raising too large a portion of the national revenue by indirect taxation; and Professor Cohn here shows how the Swiss have endeavored to remedy this by laying a large share of the burden on property and income. Mr. H. L. Osgood has a paper on "Scientific Anarchism," in which he traces back the doctrine to Proudhon as its real originator, and then shows what changes it has undergone at the hands of the "Individualistic Anarchists" and the "Internationals," concluding with a brief but decisive argument against the whole scheme. Besides the various essays, the *Quarterly* has an extended review of Bryce's "American Commonwealth," by Professor Woodrow Wilson.

READY MONDAY, MARCH 11.

JANUS.

By Edward Ireneus Stevenson, author of 'The White Cockade,' etc. 12mo, cloth, \$1.00; paper covers, 50 cents.

A dramatic and powerful romance with an art motive. Built upon a musical theme, a succession of brilliant scenes and situations hurries the reader onward to the end without a moment's pause. The work will have an especial interest for lovers of art and music; but in the vigorous action of the story, the contest of passion with honor, the infidelity of the wife, the betrayal of the friend, and the tragic climax, there is likewise interest for every class and condition of readers.

AN AMERICAN VENDETTA.

By T. C. Crawford, late London Correspondent of the New York World. Illustrated fully by Graves. 12mo, cloth, \$1.00; paper, 50 cents.

This book contains a series of most graphic pictures of a land of barbarism, few could imagine possible to find in this country of boasted freedom and civilization.

THE POSITIVE PHILOSOPHY.

By Auguste Comte. Translated by Harriet Martineau. Large 8vo, cloth, gilt top, large new type. Price, \$4.00.

This is a translation, by a strikingly clever mind, of the great philosopher who has been called the Escon of the Nineteenth Century, in handy shape, and brought within reach of all orders of readers. The translation of this grand monument of human genius is in itself a masterpiece.

LEAVES FROM A DRUMMER'S DIARY.

By Charles S. Plummer. 12mo, cloth, \$1.00; paper covers, 50 cents.

A neat and compact work, of sterling value to the Commercial Travellers of the United States, to whom it is dedicated, and an indispensable companion to any Drummer, young or old, who would succeed on the road. The information it contains is clear, practical, and of obvious importance, touching as it does every fibre of the drummer's duty, whether as to his customers or his employers. In it the Drummers tell their funny experiences and indulge in a constant flow of wit and humor. The book can be read with profit and pleasure by any person.

ROUSSEAU'S CONFESSIONS

Superbly illustrated and with a portrait of the author. By Jean Jacques Rousseau. Large 12mo, gilt top, 3 vols. in 1. Price, \$1.50.

Rousseau, the Man of Nature, who with his pen overthrew the French Monarchy, and smote the head off the sixteenth Louis, never wrote so bitterly, so pathetically, so divinely, and so meanly as in "The Confessions."

ROCHEFOUCAULD'S MORAL MAXIMS.

With steel portrait of the author. Large 12mo, gilt top. Price, \$1.00.

"Hypocrisy is the homage which vice renders to virtue," is a phrase which would alone have entitled Rochefoucauld to fame.

A BLUE-GRASS THOROUGH-BRED.

By "Tom Johnson." 12mo, cloth, \$1.00; illustrated paper covers, 50 cents.

A richly colored panorama of scenes and incidents in the Blue-grass region of Kentucky. The reader is borne breathlessly onward through a series of charming live episodes, horse-races, an attempted murder, the terrible revenge of a wronged husband, and a clever Wall Street exposé. Above all towers the gallant and knightly figure of the noble Thoroughbred himself.

OUR PARIASHS AMONG THE TRAMPS.

By Uncle Tim. 12mo, cloth, \$1.00; paper covers, 50 cents.

A volume of rare interest and information from the pen of a writer thoroughly conversant with that philosophy which bears upon the well-being of society and every-day life. It presents its arguments in a most attractive form and in the guise of absolute experience.

HIS FATAL SUCCESS.

By Malcolm Bell. With Illustrated Cover by E. Hamilton Bell. 12mo, cloth, \$1.00; paper covers, 50 cents.

A novel founded upon the occult, but in an entirely original manner. The possibilities suggested by this story are startling, almost terrifying, and might well serve as a warning to the many who in these days are blindly groping into the spectre-haunted gloom of Spiritualism and Theosophy.

BELFORD, CLARKE & CO., Publishers, New York, Chicago, and San Francisco.

— Houghton, Mifflin, & Co. have just issued a new life-size portrait of Dr. Holmes, which is even better than the earlier one.

— Charles Scribner's Sons have in preparation a handsome popular library edition, in four 12mo volumes, of Bourrienne's well-known "Memoirs of Napoleon," a standard work of which many hundreds of imported sets have been sold every year. This new edition will be an exact reprint of the latest English edition, and will contain the thirty-eight portraits of the original, together with all the other features that give distinction to the work. The price will be sufficiently low to bring these volumes within reach of all would-be readers.

— G. P. Putnam's Sons have in press, as their own commemoration of the centennial anniversary of the inauguration of Washington, a unique limited edition of Irving's "Life of Washington,"—a work for which Bryant predicted "a deathless renown." The set will be issued in five volumes, handsomely printed in large quarto form, and will contain 200 illustrations, comprising 130 steel plates and 70 woodcuts printed on India paper and inlaid in the text. The plates include portraits of all the noteworthy generals and statesmen of the American Revolution. But 300 sets will be issued, and the type will be distributed as printed from. The price to subscribers has been fixed at \$50.

— Mrs. Stowe has been able to revise the biography of herself, written by the Rev. Charles Stowe and Mr. Kirk Munroe. It will be published at an early day by Houghton, Mifflin, & Co.

— Baron Grancy will shortly issue, in Paris, a volume on American customs. It is to be in the shape of a novel, to be entitled "A French Ranch in Dakota," and will treat wholly of Dakotan affairs. The author, according to a despatch to the New York *World*, is the original founder of the Fleur de Lys settlement of French horse-breeders, whose life in Dakota this book is meant to describe.

LETTERS TO THE EDITOR.

* * * Correspondents are requested to be as brief as possible. The writer's name is in all cases required as proof of good faith.
The editor will be glad to publish any queries consonant with the character of the journal.
Twenty copies of the number containing his communication will be furnished free to any correspondent on request.

An Acoustic Mill.

WHEN a vibrating tuning-fork is brought near to a light body, like a pith-ball or a small piece of paper, the latter moves towards the fork as if attracted by it. This phenomenon was observed by Guyot in 1832, and was rediscovered by Guthrie in 1870. It has been supposed by some that gravitation could be explained by the vibratory motions, such as atoms and molecules are known to have; but it does not appear that gravitation sustains any quantitative relation whatever to the temperature of a body, such as would be the case if molecular vibration was the cause of it. The observed phenomenon may be accounted for thus. When the prong of the tuning-fork beats outwards, the air is driven before it and is condensed, while behind it there is a partial vacuum. If the velocity of the prong was greater than that of a particle of air in its free path movement, then there would be a complete vacuum behind the prong. As the latter beats to and fro, it is obvious that the density of the air adjacent to the prong must be less than if the latter was at rest, the difference depending upon the relative velocity of the prong to that of the molecules of air in their free path movements. As the pressure of the air varies as its density, it follows that the air-pressure is less in the neighborhood of the vibrating fork than at a distance from it. Hence, if an object is near to the vibrating fork, the air-pressure will be greater on the remote side, and will push the object towards the source of vibrations.

Numerous devices have been invented by Doornak and Strop to illustrate this principle. Most of them are too complicated and costly to be had by more than a few. The following is simple enough, and can be available for any one having a Chladni plate.

Cut a disk three or four inches in diameter out of letter-paper, and then cut eight or ten radial slits from the circumference half-way to the centre, and turn up one edge of each sector so as to form a kind of paper windmill. Suspend this by a thread from

its centre, and see that it hangs horizontally, which may be done by fixing a bit of beeswax to the middle of the disk, and have the thread go through it. Adjustment will be easy and quick by slight pressure upon the wax, changing the relative position of the thread.

This disk may now be brought over a properly mounted Chladni plate near the edge, and as close to it as possible, while allowing it free space for rotation without touching the plate. If the plate be made to vibrate vigorously, the disk will begin to spin, turning in the same direction as if a current of air were blowing upon it from above. The lower components of the sound of the plate will be necessary to make so large a disk as the above to spin, as the higher ones have too many nodes. The fundamental is the best; and, if it can be produced with an amplitude of an eighth of an inch or more, the disk will go round two or three times a second. Of course, the bow should be drawn across the edge opposite to the disk, in order to prevent a node being formed underneath it, and also to avoid the disturbance from movements of the air. I have found that the fundamental vibration of the Chladni plate can more easily be produced by bowing it with a round wooden rod well rosined, than with the ordinary violin-bow. In this experiment the pressure of the air is lessened between the nodes at the surface of the disk, and the space thus affected extends to the height of an inch or two. It is also evident that the light dust that moves to the place of greatest disturbance is moved there by the difference in air-pressure instead of by little whirlwinds caused by the vibrations, as it was explained by Faraday.

A. E. DOLBEAR.

College Hill, Mass., March 5.

Note on the Robinson Anemometer Constant.

THIS is the factor by which the velocity of the central point of the cups is reduced to the actual velocity of wind. When Dr. Robinson first invented his anemometer in 1860, he determined the value of this factor, for all patterns of the instrument, to be exactly 3, and this has been in use for all patterns ever since. But by the experiments of Dr. Dohrandt at St. Petersburg in 1878, this constant, for the Kew pattern at least, was found to be much less, which led Dr. Robinson to repeat his experiments; and the result was a confirmation of Dr. Dohrandt's result, and showed that his own factor is erroneous. Experiments at the Deutsche Seewarte in Hamburg have also given a factor much smaller.

The labor of the wind-force committee of the Royal Meteorological Society, referred to in my previous note (*Science*, xiii. p. 171), has been directed mostly toward determining this factor for several anemometers of different patterns, which are as follows:—

	Arms.	Diam. of Cups.
	Inches.	Inches.
Kew Standard	24.00	9.0
A 19	5.80	4.0
A 21	6.75	2.5

These were placed near the end of a long arm of a whirling apparatus, moved by a small steam-engine with varying velocities. The number of turns of the anemometer compared with that of the whirling apparatus during any given time of uniform velocity, the relations between the length of the arm of the anemometer and the distance on the arm from the centre of whirling being known, gave the ratio between the velocities, and so the value of the constant, which is found to be about the same for all, except very small velocities.

The average of 58 experiments with the Kew Standard gives 2.15 instead of 3 for the value of this constant. From 51 experiments made with A 19, the value 2.51 was obtained, while the average of 49 experiments with A 21 gave 2.96, which is very nearly that determined by Dr. Robinson, and now in use. It is seen, therefore, that while the Robinson factor is very erroneous for the Kew pattern, and also for A 19, but especially the former, it is very nearly

correct for A 21. The use of the factor 3 for all patterns of anemometers now for nearly thirty years has introduced a great amount of error in published wind velocities; so that they are not only not comparable generally with one another, but the errors have likewise affected most, if not all, the results obtained from the discussions of these velocities. It is much to be regretted, therefore, that some standard pattern had not been adopted and its constant accurately determined at the start, instead of deferring it for nearly thirty years; for, if this is even now done, it will be a long time before any adopted standard and its true constant can come into general use.

Since the force of the wind is as the square of the velocity, errors in the estimated velocity of the wind give rise to errors in the pressure of the wind which are proportionately more than twice as great. For instance: if the true velocity of the wind is 30 miles per hour, the Kew Standard with its factor 3 makes it 42 miles nearly, an increase in the ratio of 1 to 1.4; but the force of the wind is increased in the ratio of 30^2 to 42^2 , or as 1 to 2 nearly, and so in a ratio more than double the preceding one. In estimating the force of the wind from the indications of the anemometer, the effect of the error in the factor 3 of the anemometer, and of the wind-pressure constant .005, now in general use, are both in the same direction; so that the combined errors of both are very great. For instance: in the case of a wind of 30 miles per hour, we have seen above, that the error of the factor 3 applied to the Kew Standard increases the force of the wind in the ratio of 1 to 2; and if the wind-pressure constant should be .003 instead of .005, then the effect of both errors is to increase the estimated force of the wind above the true force in the ratio of 1 to $2 \times \frac{5}{3}$, or to more than three times the real force. Of course, this is an extreme, but not an impossible case; for in anemometers mostly used the error of the factor 3 is not nearly so great as for the Kew Standard, and the true value of the wind-pressure constant may come out a little more than .003 when accurately determined, but still the errors of estimated wind forces, with the constants in use, are undoubtedly enormously large. Mr. Whipple, of the wind-force committee, says, that, "unless the Robinson anemometers could be put into the hands of those who would take care of them, their indications were frequently worse than useless. The instruments require to be continually looked after. Even if carefully attended to and regularly cleaned and well oiled, their records are far from satisfactory."

It is the opinion of the writer that they must in time give way to something better, probably to Mr. Dines' newly invented helioid anemometer, which is more simple in its mechanical action, and, according to the experiments made with it, seems quite satisfactory. A description of this instrument is found in the *Quarterly Journal of the Royal Meteorological Society* for July, 1887.

WM. FERREL.

The Soaring of Birds.

THERE can be no doubt that the explanation of soaring given by Mr. Gilbert is mechanically sound. The only remaining question seems to be as to its sufficiency. In regard to this question, the following considerations may be of service:—

There is a certain velocity relative to the air such that a bird possessing it can be sustained against gravity without muscular exertion. Let V represent that velocity for a given bird. Let there be two horizontal layers of air, whose relative velocity is z . For simplicity, let the velocity of the lower layer be zero, that of the upper z . Suppose the bird at some instant to be in the upper layer, moving in the same direction with it, and with a velocity relative to it of V , so that he can just be sustained while moving horizontally. His velocity relative to the lower layer is $V+z$. Let him now descend into the lower layer and wheel horizontally 180 degrees. In so doing he necessarily loses some energy, and his velocity decreases. Now, in order that he may be sustained at the same level during the wheeling, his velocity relative to the lower layer must not fall below V . Suppose his decrease of velocity to be a little less than z ; he will then be moving opposite to the direction of the upper current, with a velocity greater than V . He can therefore not only maintain his level, but can rise. Let him now enter the upper layer, his velocity relative to it being $V+z$. If, now, he

can wheel horizontally through 180 degrees without losing more than the velocity z , he will be in a position to repeat the cycle.

The statement of Professor Oliver in *Science* (xiii. p. 16) seems to imply that the difference in velocity of the air-currents needs to be as great as the relative velocity which will enable the bird to sustain himself against gravity; that is, that z must be as great as V . If the discussion here given is correct, such is not the case. It is only necessary that the bird should have initially a sufficient relative velocity, and should be able to wheel horizontally 180 degrees without losing by "friction" enough energy to reduce his velocity as much as z , the velocity of one air-current relative to the other.

L. M. HOSKINS.

University of Wisconsin, Madison, March 5.

"Shall We Teach Geology?"

WHEN a reviewer bases critical verdicts on ignorance or misapprehension of the work reviewed, he has an advantage over the author, of which, in my own experience, I usually leave him in quiet possession. Still the meekness of silence may not always prove most useful to the public. Your reviewer of my work, "Shall We Teach Geology?" in No. 317, says that I ignore the mental and moral sciences as means of culture; but he should have observed that I do not undertake to discuss the education value of all sciences and literatures, but only of those selected as types by certain pedagogical writers who hold geology in disesteem. Your reviewer states that I mention "history only to slight it, declaring that it trains no faculty but verbal memory." My criticisms on history contemplate it as a study urged upon children in the early stages of education. This is what I have recorded on purpose to forestall such an accusation. "My present investigation concerns studies as usually taught and in schools of the lower orders. In college, history and literature are pursued in a nobler and more cultural way" (p. 148). Your reviewer employs the term "literature" in the wide sense, which makes it a much more valuable thing than literature as used in the narrow sense of the author, whose positions I am examining (note, p. 145). Your reviewer states, also, that I claim for geology that "the subject should be taken up in the primary schools, and pursued every year as long as the student attends school." This is preposterous criticism. Such is not my position, nor is the idea anywhere conveyed. I think the subject should be taken up briefly, two, three, or more times, at successive stages of mental development, not completed in one course late in school-life (see pp. 133, 134).

ALEXANDER WINCHELL.

Ann Arbor, Mich., March 5.

To keep Water-Mounts Moist.

In my last communication on this subject (*Science*, xiii. p. 170) I recommended glass capillary tubes. I since find that a much simpler plan, and one that serves equally well in most cases, is to suspend from the edge of the cover-glass, to a beaker of water beneath, a moistened piece of filter-paper about four centimetres long and half a centimetre wide.

Likewise, in the study of germination of seeds, the capillary tubes or the moistened filter-paper may be put to good service. Very clean and satisfactory specimens of the first stages of germination may be obtained by placing the moistened seeds in contact one with another on a glass slip over a beaker of water, and suspending from their midst to the water one of the tubes or simply a narrow piece of paper. A bell-jar will exclude dust.

E. B. KNERR.

Parsons College, Fairfield, Io., March 6.

The Wind-Pressure Constant.

IN my note I see you have put Hazen for Hagen. The latter is a German physicist of Berlin. Will you please make the correction in your next number? This is important, since Hazen has also made experiments, the results of which differ very much from Hagen's, and it may seem that I have misrepresented his results.

WM. FERREL.

Kansas City, Mo., March 5.

GUARANTY INVESTMENT COMPANY

CAPITAL \$250,000.

Offices: Atchison, Kan. 191 Broadway, New York. 222 Walnut St., Phila.

Hon. ALBERT H. HORTON (Chief Justice, Kansas Supreme Court), Topeka, Kan., Pres't.

7% Guaranteed Farm Mortgages 7%

The Guaranty Investment Company makes loans upon fertile farms in the choicest portions of Kansas and Nebraska and has adopted the policy of sending a Committee of its Investors each year to examine its loans and methods of business.

The Committee this year consisted of PROF. A. H. BERLIN, Principal of the High School Montrose, Pa., and MAJ. THEODORE L. POOLE, Ex-U. S. Pension Agent, Syracuse, N. Y. Both of these gentlemen are persons of the highest character and have the confidence of the Communities in which they reside.

The Committee has recently returned and has made a very interesting Report upon the general development of Kansas and Nebraska as well as the business of the Company. The Company will be glad to send this Report to any address.

The following names are taken from the long list of Investors in our Mortgages:

(See if Some Friend of Yours is not in the List.)

William A. Caudwell, 59 Liberty St., N.Y.
 Palmer Cox, 68 Broadway, N.Y.
 Rev. Jos. B. Ryland, D.D., 11 Livingston Place, N.Y.
 Rev. Brady E. Backus, D.D., 360 West 28th St., N.Y.
 Rev. R. M. Sommerville, 126 West 45th St., N.Y.
 Dr. Robert A. Murray, 235 West 23d St., N.Y.
 Dr. James P. Tuttle, 156 West 41st St., N.Y.
 H. Edwards Rowland, 218 Fulton St., N.Y.
 Irving H. Tift, Esq., 272 Broadway, N.Y.
 Prof. D. G. Eaton, 53 Pineapple St., Brooklyn, N.Y.
 Dr. E. P. Thwing, 156 St. Marks Ave., Brooklyn, N.Y.
 Dr. C. C. Miles, Greenport, N.Y.
 John V. N. Bergen, Port Jefferson, N.Y.
 Benj. W. Stillwell, Yonkers, N.Y.

R. C. Coleman, Goshen, N.Y.
 Mrs. Samuel Carlisle, Newburg, N.Y.
 Dr. C. C. Bartholomew, Ogdensburg, N.Y.
 Rev. Nelson Millard, D.D., Rochester, N.Y.
 Rev. Horace G. Hinsdale, D.D., Princeton, N. J.
 Dr. Charles M. Howe, Passaic, N. J.
 George A. Skinner, 5 Railroad Place, Newark, N. J.
 Dr. Edwin M. Howe, 85 Halsey St., Newark, N. J.
 Dr. H. G. Buckingham, Clayton, N. J.
 Dr. Martin Cole, Jr., Hainesville, N. J.
 Mortgage Trust Co. of Pa., Philadelphia, Pa.
 Miss Mary Miller, 1220 Spruce St., Philadelphia, Pa.
 Henry D. Biddle, 317 1/2 Walnut St., Philadelphia, Pa.

Dr. Calvin C. Halsey, Montrose, Pa.
 Rev. William Baldwin, Great Bend, Pa.
 Gen. William Lilly, Mauch Chunk, Pa.
 Second Nat. Bank, Mauch Chunk, Pa.
 Enos E. Thatcher, West Chester, Pa.
 Mrs. Townsend Poore, Scranton, Pa.
 Rev. Burdett Hart, D.D., New Haven, Conn.
 Dr. Frank H. Wheeler, New Haven, Conn.
 Charles R. Christy, Stamford, Conn.
 Mrs. Catharine P. Fuller, Woodmont, Conn.
 Miss Jessie Henderson, Lenox, Mass.
 Dr. M. J. Halloran, Worcester, Mass.
 Albert Walker, Bennington, Vt.

Address for Report and Monthly Bulletin

HENRY A. RILEY, General Eastern Manager, 191 Broadway, N.Y.

ONE LANGUAGE FOR THE WHOLE WORLD.

WORLD-ENGLISH :

THE UNIVERSAL LANGUAGE. 25 CENTS.

EVERY one has heard of the butcher who, after a long search for his knife, at last found it in his mouth: so speakers of English have been seeking for a universal language, when, lo! it is in their mouths. The intelligibility of English words has been obscured by a dense mist of letters. This is now dispersed by A. Melville Bell, who has already won a world-wide reputation through his invention of "Visible Speech," the great boon to deaf-mutes. Professor Bell calls this new discovery of his "World-English," and the result is a language which cannot fail to meet with acceptance, and at once supersede the supposed necessity for "Volapük," or any other artificial language. No language could be invented for international use that would surpass English in grammatical simplicity, and in general fitness to become the tongue of the world. It is already the mother-tongue of increasing millions in both hemispheres, and some knowledge of the language is demanded by all educated populations on the globe. Social and commercial necessities require that the acquisition of this knowledge shall be facilitated, and it is believed that Professor Bell's invention has removed the last impediment to English becoming the universal language, for which vague desires have long been entertained, although hitherto only futile efforts have been made.

Ex-President Andrew D. White, of Cornell University, says: "I believe that the highest interests of Christian civilization and of humanity would be served by its adoption. China and Japan would be made English-speaking peoples within fifty years, and so brought within the range of Christianizing and civilizing ideas, in the largest sense. All existing missionary work is trivial as compared with this. For your system would throw wide open those vast countries, as, indeed, all the countries of the world, to the whole current of English and American thought."

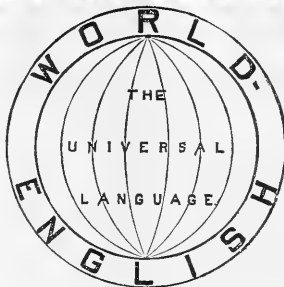

For Diffusion of English throughout the World

THE UNIVERSAL LANGUAGE

This "Hand-Book of World-English" is the Complete, Simple, and Efficient Medium.

FOREIGNERS

Will Acquire, by Means of this Hand-Book, a PERFECT PRONUNCIATION OF ENGLISH.

For Primary School Pupils and Illiterate Adults

World-English is a Royal Road to Reading.

To Teachers of English and Modern Languages

This Hand-Book will be of Primary Importance as a Phonetic Directory.

DEFECTS OF SPEECH

Will be Readily Corrected by Means of the Articulate Directives in this Hand-Book.

HAND-BOOK OF WORLD-ENGLISH,

25 CENTS.

The plan of this little book is altogether new. Letters and sounds are so associated, in all the exercises, that from the mere knowledge of letters a learner cannot fail to pronounce words with certainty. English reading will thus be easily acquired, whether by natives or foreigners, children or adults.

The general resemblance of World-English to Literary English is such that any reader of the latter deciphers the former at sight, or, at most, after a few minutes' study of the new letters. A like result may be anticipated for those who shall learn to read from World-English. They will transfer their power of reading to the literary form of the language, almost without effort. The orthographic aspect of words will, besides, be so fixed in the eye, by contrast, that spelling will be remembered as — what it really is — a pictorial association with words.

No special training is required to qualify teachers for using this book. The subject can even be successfully introduced in the kindergarten and the nursery. This phonetic mode of initiation in reading cannot be too strongly urged on the attention of School Boards on both sides of the Atlantic.

The ordinary orthography of each word is interlined with the World-English version throughout the Exercises and Readings.

So set down, our tongue is the best for the world to unite upon. — *Brooklyn Eagle*.

The idea of Mr. Bell has much to recommend it, and the presentation is charmingly clear. — *American*, Phila.

The result is a language which cannot fail to meet with acceptance. — *Boston Traveller*.

Has the merit of great ingenuity. — *Railway Age*.

His treatise, as a study of English orthoepy, condenses the result of much thought and experience in small compass. — *The Critic*.

World-English is the English language unburdened of its chaotic spelling. — *Popular Science Monthly*.

We commend it to the attention of teachers. — *Ottawa Globe*.

"World-English" and "Hand-Book of World-English" can be had of all booksellers, or will be sent for 50 cents, post free, by the publisher,

N. D. C. HODGES, 47 Lafayette Place, New York.

C. & C. ELECTRIC MOTOR COMPANY.

Electric Motors
FOR
Arc and Incandescent Circuits, Most Economical Motor on the Market.
Regulation Perfect.
Motors Designed for all Power Purposes.

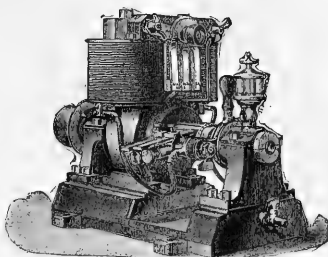

OFFICE and MANUFACTORY:
402 and 404 Greenwich Street, New York City.
New England Office, 19 Pearl St., Boston.
Philadelphia Office, 301 Arch St.
Western Office, 139-141 Adams Street, Chicago.
Southern Office, 25 Carondelet Street, New Orleans.

Schools.

NEW JERSEY, PLAINFIELD.
THE CHESTNUTS.—Parents with daughters to educate, or orphan girls with companion, may find a comfortable home, with school instruction by applying to Miss E. E. Kenyon.

CONNECTICUT, NEW HAVEN.
MRS. CADY'S SCHOOL FOR YOUNG LADIES. Prepares for Smith and Wellesley, and admits to Vassar by Certificate. Circulars. Early application necessary.

VERMONT, BURLINGTON.
VERMONT EPISCOPAL INSTITUTE. Boarding School for Boys. Prepares for College or Business. Military drill. Terms moderate. Fifty-seventh half-year opens September 3, 1888. Send for catalogue. H. H. ROSS, A.M., Principal.

TERRE HAUTE, IND.
ROSE POLYTECHNIC INSTITUTE.—A School of Engineering. Well endowed, well equipped departments of Mechanical and Civil Engineering, Electricity, Chemistry, Drawing. Extensive Shops & Laboratories. Expenses low. For catalogue address F. C. Mendenhall, Pres.

Brokers and Auctioneers.

R. ELLIS & CO.

BUSINESS, HOTEL AND PATENT BROKERS, AUCTIONEERS, ETC.

No. 176 BROADWAY,

Room 46. New York

CLIENTS ADVISED FREE OF CHARGE.

J. P. TRAVER & CO.,

General Auctioneers,

Real Estate and Business Brokers,

OFFICE, 23 PARK ROW,

OPPOSITE POST OFFICE, (ROOMS 14 & 15.) New York.

Mortgages Foreclosed. Cash Advanced on Consignments.

Property of Every Description Bought, Sold and Exchanged.

Readers of Science

Corresponding with or visiting Advertisers will confer a great favor by mentioning the paper.

Scientific Apparatus.

J. GRUNOW,

621 Sixth Avenue, New York.
Established 1852.

MAKER OF

Microscope Stands, Oil Immersion Objectives and Abbe Condensers for Bacterial and Histological work, of Objectives, Camera Lucida and other accessory apparatus.



W. H. WALMSLEY & CO.

SUCCESSORS TO

R. & J. BECK,

1016 Chestnut Street Phila

Microscopes and all Accessories and Apparatus. Photographic and Photo-Micrographic Apparatus and Outfits.

Spectacles, Eye Glasses, Opera and Marine Glasses, etc.

Illustrated Price List mailed free to any address. Mention SCIENCE in corresponding with us.



IMPROVED OIL LIGHT MAGIC LANTERNS.

Also Lime and Electric Light Apparatus, and mechanical, plain, and fine colored views.

J. B. COLT & CO., Manufacturers,
No. 16 BEEKMAN STREET, NEW YORK.

MAGIC LANTERNS Stereopticons and the Best Views for Public, Church, Home, and Scientific Exhibitions. Best apparatus, new views. Largest stock. Reduced prices. 24 Years' Practical Experience. Illus. Catalogue Free.

GEO. H. PIERCE,
136 S. Eleventh St., Philadelphia, Pa

ELECTRICAL TESTING BUREAU,

Johns Hopkins University, Baltimore, Md.

Resistance Coils and Boxes Compared.

Am meters and Volt meters calibrated.

Condensers standardized.

Primary and Secondary Batteries Tested.

Efficiency of Dynamos and Motors Determined.

Insulation of Cables and Wires Tested.

Etc., Etc.

Circulars describing Methods Used, Prices, Etc., sent on Application.

Address as above.



E. & H. T. ANTHONY & CO.
597 Broadway, N.Y.

Manufacturers and Importers of

PHOTOGRAPHIC INSTRUMENTS,

Apparatus and Supplies of every

description. Sole proprietors of the

Patent Detective, Fairy, Novel,

and Bicycle Cameras, and the

Celebrated Stanley Dry Plates.

Amateur Outfits in great variety, from \$5.00 upward.

Send for Catalogue or call and examine. More than 40 years established in this line of business.

WHITALL'S PLANISPHERES OR DIRECTORY OF THE STARRY HEAVENS name and locate all Stars, Constellations, and Planets visible at any given minute of time. Should be used by every one. Ask your stationer, or address WM. T. COOPER, Manager, 307 Race St., Philadelphia, Pa.

SCHOOLS AND COLLEGES

will have a positive advantage by ordering their furniture apparatus and supplies from C. PARDO & CO.,

31 East 17th St., New York.

TO EMPLOYERS.

Having purchased the fixtures, good will, &c., of the NEW YORK EMPLOYMENT BUREAU at No. 681 BROADWAY, in this city, we request the patronage of the public in the future. We desire to fill a long-felt want for an employment bureau, where only the best grade of male help is dealt in, and it is our aim to send ONLY such help as is ordered in every instance, and our patrons can rely on us to send strictly first-class help, the references of whom we personally investigate before sending to any one. We simply request a trial, and are convinced that we will give satisfaction in every case. We have on hand help in every branch, which we can send upon receipt of telegram or letter, AND FOR WHICH WE MAKE NO CHARGE TO AN EMPLOYER.

NEW YORK EMPLOYMENT BUREAU,

(AS REORGANIZED).

Arnold, Constable & Co. FLANNELS.

Fancy Silk Mixture Scotch Flannels
FIGURED AND FANCY
STRIPE FRENCH FLANNELS,
NOVELTIES IN TENNIS-SUITINGS.
Colored White Opera Flannels.
Broadway & 19th st.
New York.

DRESS GOODS FOR SPRING

We are now exhibiting our Novelties in Dress Goods for Spring and Summer.

An extensive variety of fine wool and silk mixed fabrics, in new shades; Summer Tweeds, with handsome selvages; French Chevrons with Shepherd Check side band; and many other new styles.

Advance styles in Figured Challie; India Silk in Exclusive designs; Mohair, Brilliantine and Pongee Gloriosa in a fine range of colors.

JAMES MCCREEK

BROADWAY AND ELEVENTH STREET,
NEW YORK.

SPECIAL TEACHER'S EXCURSION TO

PARIS EUROPE AND THE WORLD'S EXPOSITION,

visiting England, France, Germany, the Rhine, Belgium and Holland. All travel and hotels FIRST-CLASS. Finest line of Steamers crossing the Atlantic. Low Rates, Rooms are being rapidly taken. Send for circular, free.
E. TOURJEE, Franklin Square, Boston, Mass.

FOOD ADULTERATION

And its Detection. With photomicrographic plates and a bibliographical appendix. By J. P. Battershall. 328 pages, 8vo, cloth. Price, \$3.50. Circulars and Catalogues on application. E. & F. N. SPON, 12 Corlandt St., New York.

KIMBALL'S STRAIGHT CUT CIGARETTES

Unsurpassed in quality. Used by people of refined taste. Highest award at Brussels, 1888. The finest smoking mixtures are of our manufacture. Fifteen First Prize Medals. WM. S. KIMBALL & CO., Rochester, N.Y.

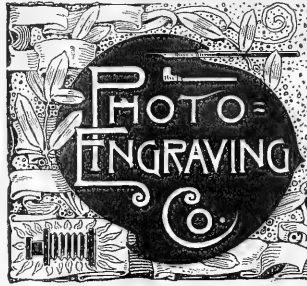

JOHN HASTINGS = Pres't.
A. R. HART = Gen. Manager.
JOS. TRIPP = V. Pres't.

ENGRAVING FOR ALL ILLUSTRATIVE AND ADVERTISING PURPOSES

BRANCH AT 72 1/2 CHESTNUT ST.
PHILADELPHIA, PA.

67-71 PARK PLACE,
NEW YORK.

THE CHEQUE BANK LIMITED.

ESTABLISHED IN LONDON, 1873.

CHIEF OFFICE, 4 Waterloo Place, Pall Mall, London.

TRUSTEES:

The Right Honorable JOHN BRIGHT, M.P.
The Right Honorable EARL BEAUCAMP.
Bankers: Bank of England.

The Capital of the Bank and its Guarantee Fund of 500 is invested in Government Securities.

The Bank does not discount Notes or Bills, nor speculate, but loans its Deposits against Government Securities, thus making the Cheque Bank Cheques EQUAL TO CASH—as Bank of England Notes are.

The Cheque Bank issues Cheques singly or in books from ONE POUND upwards, for the use of Travelers, and for others remitting money to Europe, available in every town in England, Scotland, Ireland, and Wales. In every town of Europe, and all other parts of the world.

Cheque Bank Cheques are accepted as Cash by all the British Government Offices.

VISITORS TO THE PARIS EXHIBITION this summer can get the Cheque Bank Cheques cashed at 30 Banking Houses in Paris.

Travelers and others holding Cheque Bank Cheques can have their mail matter addressed to them, care of the Cheque Bank, London, who will take charge of the same and forward to any address.

For Hand-Book containing List of upwards of 2000 principal Banking Houses throughout the World and the Cheque Bank Cheques, and for all information apply to the AGENCY.

CHEQUE BANK, Limited,
UNITED BANK BUILDING,
2 Wall St., New York.

E. J. Mathews & Co., Agents.

REFERENCES BY PERMISSION:
JNO. W. MACKAY, Esq., President Commercial Cable Company, Mackay-Bennett Cables, New York.

F. O. FRENCH, Esq., President Manhattan Trust Co., New York, and others.

KNABE PIANOFORTES.

UNEQUALLED IN

Tone, Touch, Workmanship and Durability.

WILLIAM KNABE & CO.
NEW YORK: No. 112 Fifth Av., above 16th St.
BALTIMORE: Nos. 22 and 24 E. Baltimore St.
WASHINGTON: No. 817 Market Space, Penn. Av., near 9th St.



GOOD NEWS TO LADIES.

Greatest Inducements ever offered. Now's your time to get up orders for our celebrated Teas and Coffees, and secure a beautiful Gold Band or Moss Rose China Tea Set, Dinner set, Gold Band Moss Rose Toilet Set, Watch, Brass Lamp, or Webster's Dictionary. For full particulars address THE GREAT AMERICAN TEA CO., P. O. Box 289, 31 and 33 Vesey St., New York.

A NEW MAGAZINE—THE SWISS CROSS

Devoted to spreading a love of Nature among the people. Edited by HAZELAN H. BALLARD, President of the Agrass Association, and succeeding St. Nichol's as the official magazine of that body. \$1.50 a year. Sample copy 10 cents, or 25 cents for trial subscription for 3 months. N. D. C. HODGES, PUBLISHER, Mention this paper. 47 Lafayette Place, New York.

Wants.

A YOUNG MAN can have lucrative engagement, not only a fixed salary, but according to his work accomplished in travelling for SCIENCE. A personal interview invited.

N. D. C. HODGES,
47 Lafayette Place, New York

Old and Rare Books.

A. S. CLARK, Bookseller,
34 PARK ROW, NEW YORK CITY.

A Gleaner in the By-ways of Literature. Results of Gleaning found in Catalogues issued from time to time.

CATALOGUE NO. 27 NOW READY.

BACK NUMBERS and complete sets of leading Magazines. Rates low. AM. MAG. EXCHANGE, Schoharie, N.Y.

H. WILLIAMS,

Dealer in Old Magazines, Reviews, &c. Scientific periodicals a specialty. 39 Macdougal St., N.Y.

SCOTT'S EMULSION

OF PURE COD LIVER OIL AND HYPOPHOSPHITES

Almost as Palatable as Milk.

Containing the stimulating properties of the Hypophosphites combined with the Fatening and Strengthening qualities of Cod Liver Oil, the potency of both being largely increased.

A Remedy for Consumption. For Wasting in Children. For Scrofulous Affections. For Anæmia and Debility. For Coughs, Colds & Throat Affections.

In fact, ALL diseases where there is an inflammation of the Throat and Lungs, a WASTING OF THE FLESH, and a WANT OF NERVE POWER, nothing in the world equals this palatable Emulsion.

SOLD BY ALL DRUGGISTS.



SCIENCE

[Entered at the Post-Office of New York, N.Y., as Second-Class Matter.]

A WEEKLY NEWSPAPER OF ALL THE ARTS AND SCIENCES.

SEVENTH YEAR.
VOL. XIII. No. 320.

NEW YORK, MARCH 22, 1889.

SINGLE COPIES, TEN CENTS.
\$3.50 PER YEAR, IN ADVANCE.

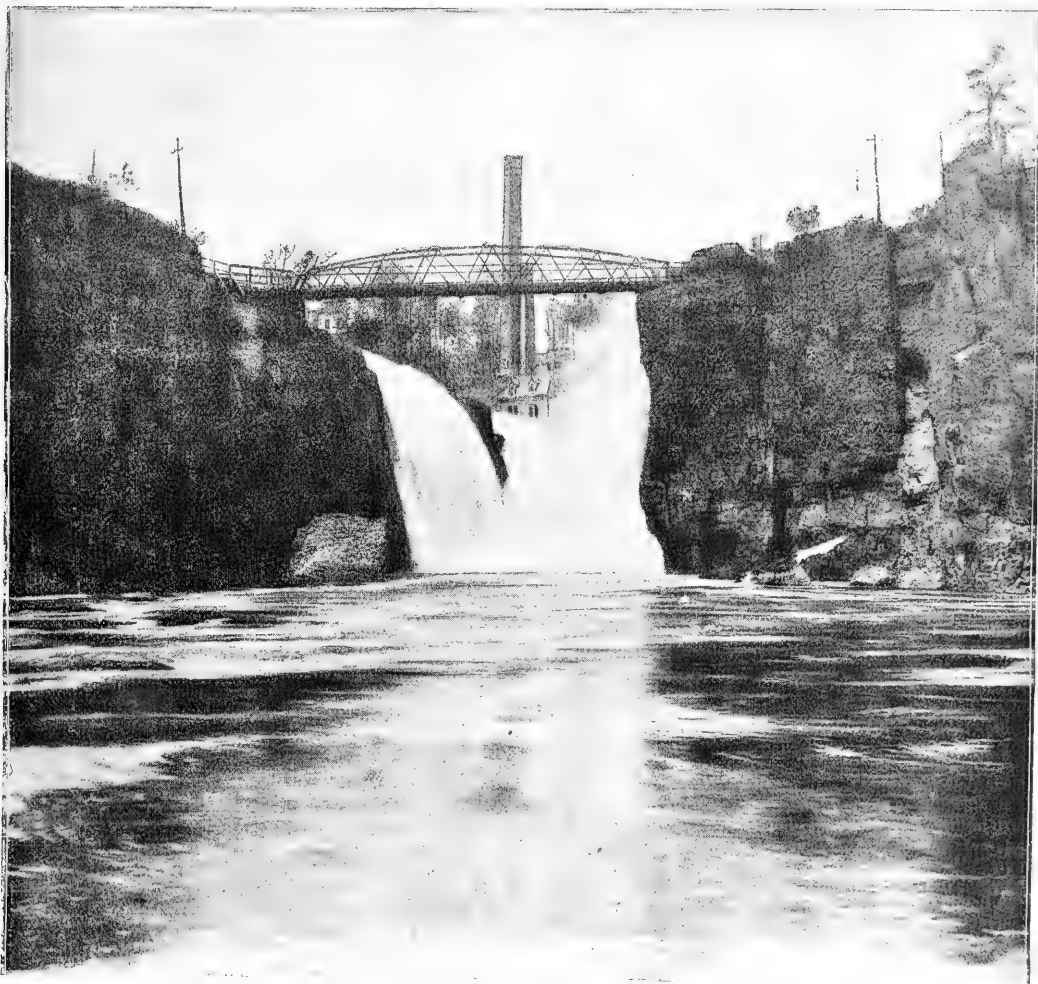

THE GREAT FALLS, ON THE PASSAIC RIVER, IN PATERSON, N.J., 15 MILES FROM NEW YORK, SHOWING WASTE OF WATER INTO THE SEA. [See p. 203.]

THE WATER PROBLEM OF NEW YORK.

THE water problem before the city of New York, how to meet the increasing demands of the vast and fast-growing population for water for domestic use, sanitary purposes, and for the requirements of commerce and manufacture, has been answered by Mr. John R. Bartlett. While engineers and politicians have been speculating with the limited possibilities of the Croton watershed, and with visionary plans for diverting the waters of the upper Ramapo River, and for getting an additional supply from the Adirondacks or Lake Erie, and have reduced to despair sanitarians and all others acquainted with the really critical condition of the city's affairs on the water question, Mr. Bartlett has been quietly maturing plans which meet the emergency practically and conclusively. He offers to furnish the city with not less than 50,000,000 gallons of pure water daily, under a head pressure of three hundred feet. He and associates have the water to sell, the unquestioned right to sell it, and will pour it into the city ready for use without demanding of the city a single dollar before the water has been delivered.

These plans have been recently presented to the sinking-fund commissioners of the city, and are elaborately set forth in a folio volume of a hundred and seventeen pages. The water is to come from the Passaic watershed, situated in the States of New Jersey and New York; and the quantity supplied to New York City will not more than equal the amount of rainfall in that portion of the watershed which lies in New York State. In the book is discussed every phase of the problem. It anticipates every question which the extent of the plans suggests, and abounds in statistics and comparative calculations which show deep research, and will be valuable for reference for all cities.

In order to properly appreciate the magnitude and the beneficence of this project, an outline of its inception and progress is necessary. The data which follow are furnished by Mr. Bartlett's book and the recent well-known history of New Jersey. They tell a story of successful enterprise, on whose completion the State of New Jersey and the entire metropolitan district are to be profoundly congratulated.

Mr. Bartlett first directed his attention to the crying demand for pure water raised by the cities and towns east of the Orange Mountains in New Jersey. Newark and Jersey City, the chief municipal centres of this region, and incidentally the suburban and adjacent towns, had been agitating the question for years. Official inquiries of engineers and health-officers instituted by these plans had evoked on each occasion the startling result that the water furnished their people was unfit for use, and was a constant menace to the health of the communities. The various examinations showed a steadily increasing danger. This was made manifestly logical and necessary by the fact that the water for this region was taken from the lower Passaic River, a tidal stream, and at a point in the river where the pollution from the fast-growing cities and increasing factories was all deposited.

The only remedy lay in getting water from a source above the point of pollution. The State was manifestly helpless, because of its inability to legislate to any particular locality rights to which all places had a just claim; nor could it attempt a general relief, because of the immense amount of money which would be required to pay for the condemned land and the taking-away of individual rights. Even if this should be accomplished by a vote of the people of the State, other serious constitutional objections interposed, and difficulties of a practical and business nature which were well-nigh insurmountable. The helplessness of the cities themselves was even more pronounced, as added to the State's difficulties were individual indebtedness and political imbroglions, which have been fully ventilated during the last year.

A unification of all interests was essential,—a harmony of action on the part of all the water companies and corporations having rights below the point designed for the source of supply, a similar harmony of all riparian owners, and a harmony of all legal rights to the water,—in fact, a condition was essential which seemed beyond the reasonable power of human energy to bring about, and this is the condition which Mr. Bartlett has successfully worked out.

The detailed story of how the history of this entire section, from

its original granting to the present time, was mastered, in order to ascertain beyond peradventure the absolute rights of every claimant; how the records of judicial action during this time were all consulted to justify these rights; how the engineering problems, as many as anticipation of any diverse plans might ever involve, were all solved; how the legal aspect of every phase of the work was fully understood at each step; how the immense business manipulations of purchasing the many acres of property and satisfying all owners were accomplished,—how all these things were done will be an interesting chapter of a future history of New Jersey. Suffice it here to note with amazement and pride that it all has been done.

The immense Passaic watershed of the States of New Jersey and New York was at command, and the water was ready to be poured into the houses of the long-suffering people. Here developed the most interesting phase of the project. The extent of the watershed is about 877 square miles. The average daily capacity is 700,000,000 gallons. A computation based on the most generous allowances, and in accordance with the well-known increasing demands for water by each succeeding generation, showed that the State of New Jersey could not within any time that fair calculation could devise, certainly not within a hundred years, use, or waste in generous use, more than 300,000,000 gallons daily. The remainder, 400,000,000 gallons, would continue as now to flow away into the sea. To devote to practical use this immense amount of water was a problem which immediately arose. The condition of New York City and its fast-increasing water wants suggested at once a proper place to bestow it. Here the Croton watershed was being taxed to its utmost capacity. Aside from the danger to a great city like New York of depending on only one source of supply for water,—a danger which all great municipalities recognize and guard against to the utmost limit,—this source was showing evidence of soon becoming insufficient to supply the requisite amount of water. Its whole capacity, with Quaker Bridge dam and every other storing contrivance utilized, would be only 250,000,000 gallons daily. To estimate the future by the records of the past, within ten years the wants of the people of New York City could not be supplied.

The dependence on a bountiful supply of water of a city's progress and welfare is so well known that it need not be argued. It is an axiom. In small towns, where the chief consumption is confined to the direct uses of the inhabitants, the amount of water used *per capita* can be small; but in a large municipality people are not the only consumers. The onward march of steam, and the various succeeding inventions of civilization, have rendered necessary an immense amount of water for their assistance. Large cities, therefore, have this quantity included in the *per capita* use of water; and, besides the other considerations of better health and greater security, a larger *per capita* use of water indicates an advanced state of prosperity. A ridiculous argument has been used in New York against increasing the water-supply. "Let the waste of water be stopped," it said: "we are using too much." The fact is, that a generous use of water could not be indulged without a generous waste. The permanent necessity of the former renders the latter not an evil, but a desirable condition. Moreover, statistics show that the ratio of increase of population does not in any degree determine the ratio of increase in the water wants of a city; because, whereas in a small community 10 gallons daily *per capita* might be sufficient, in a large community the various other uses of water mentioned above would render the *per capita* needs considerably over 50 gallons.

A striking illustration is furnished by the city of Philadelphia, where in 1810 they used 7 gallons of water *per capita*; in 1830, 17 gallons; in 1860, 36 gallons; in 1880, 68 gallons; in 1886, 80 gallons; and it is said the figures of this year will show 100 gallons.

These facts serve to show more conclusively the imminent necessity for immediate attention to New York's wants. Mr. Bartlett's efforts had brought an available quantity of water from a pure source to the opposite banks of the Hudson, where he was confronted with a new series of problems, legal and mechanical. He meets all the questions as to the right to bring the water through and out of the State of New Jersey with opinions giving specific

and unqualified indorsement from ex-Chancellor Benjamin Williamson, ex-Gov. J. D. Bedle, ex-Gov. Leon Abbett, Henry C. Pitney, Garret A. Hobart, A. Q. Keasbey, William Pennington, Henry C. Andrews, ex-Chancellor Theodore Runyon, Barker Gummere, and decisions of the courts of last resort of both States. Thus arrayed, is the best legal talent in New Jersey.

The formidable task of crossing the Hudson with absolute confidence, he also solved, and in a most remarkable manner. Instead of presuming on a plausible theory, many of which abound, Mr. Bartlett set to work on the best theory, and worked it out at a cost of nearly \$200,000. This was done for the purpose of ascertaining whether a certain opinion he held was correct or not. His opinion was that the Hudson River Tunnel, at that time practically aban-

tion of the city government. Upon receipt of the report, the board passed a resolution authorizing the committee "to recommend Mr. Bartlett's proposition to the favorable consideration of the commissioners of the sinking-fund, and urge upon them the adoption by the city of the proposition in accordance with the plans submitted, in order to secure to the city an adequate supply of water for all purposes, and to meet its present needs, and that the same be done as promptly as possible."

A board of engineers, composed of Clemens Herschel, A. Fteley, and Capt. T. W. Symons, U.S.A., carefully examined the plans of Mr. Bartlett, and made a report as follows: "We do recommend as an entirely practicable and valuable project the general plan which has been submitted by you for supplying a portion of New

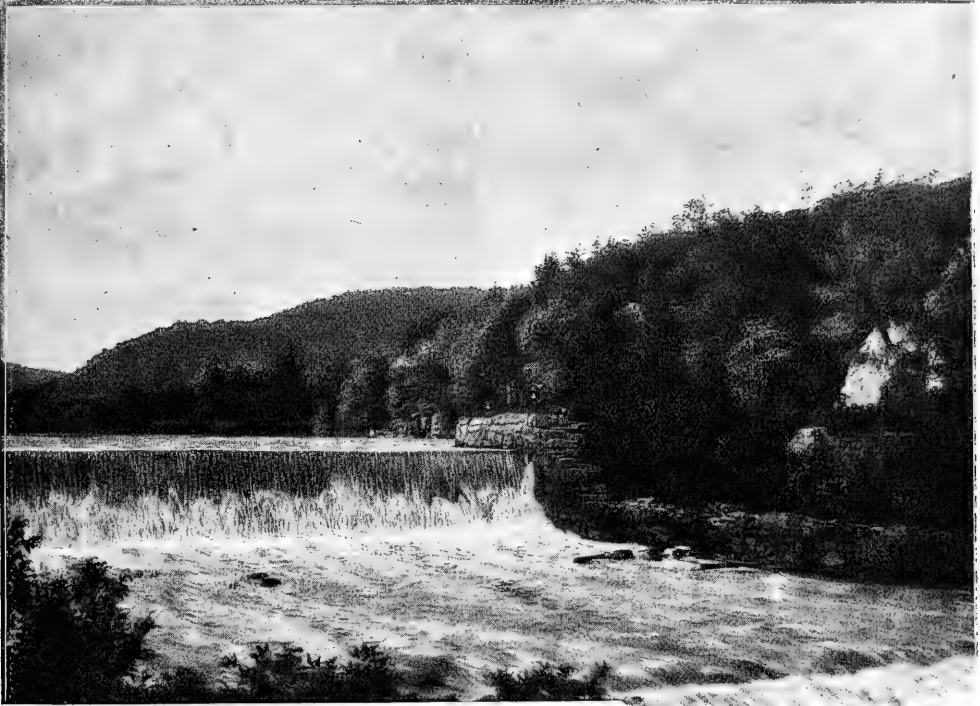

RAMAPO RIVER IN ORANGE COUNTY, N. Y., SHOWING THE VOLUME OF WATER FLOWING INTO NEW JERSEY.

done, could be made to serve the purpose of holding the conduits, the great water-mains. In this way he built a large section of the tunnel from the New Jersey end, and the fact was thoroughly demonstrated that the rest could be built the same way; and that the water-way was secure.

Accompanying the proposition of Mr. Bartlett and his associates is an indorsement, confirming all that Mr. Bartlett says of his project and its possibilities, by all the companies or societies which have any controlling water-rights below the point of diversion in the State. These are the Society for Establishing Useful Manufactures, the Lehigh Valley Railroad Company, the Dundee Water Power and Land Company, the Acquackanonk Water Company, the West Milford Storage Company, and the Montclair Water Company.

A committee appointed by the New York Board of Fire Underwriters to examine into the merits of Mr. Bartlett's plan reported that in their judgment the plan was feasible, and, if adopted, would be of great benefit to the city, and was entitled to the support and indorsement of the underwriters, and to the favorable considera-

tion of the city government. Upon receipt of the report, the board passed a resolution authorizing the committee "to recommend Mr. Bartlett's proposition to the favorable consideration of the commissioners of the sinking-fund, and urge upon them the adoption by the city of the proposition in accordance with the plans submitted, in order to secure to the city an adequate supply of water for all purposes, and to meet its present needs, and that the same be done as promptly as possible."

York City from the drainage area of that part of the Passaic watershed that lies in the State of New York, and in the manner herein described, including the use of a tunnel under the Hudson River for carrying the necessary water-conduits across the river in a safe, durable, and trustworthy manner. We summarize its principal advantages as follows: 1. It will furnish to the city of New York an independent supply of water from a new and independent source and by a new and independent route; 2. This supply will be delivered directly into those portions of the city most remote from the present source, and where the pressure is most inadequate; 3. It can be delivered under any pressure desired, up to three hundred and fifty feet of head, and supply all high buildings and districts without pumping, thus resulting in a great saving to individuals; 4. It will furnish most perfect fire protection, and consequently greatly reduce the cost of insurance."

A memorial of fire-underwriters to the commissioners of the sinking-fund of New York, upon this subject, signed by the officers of all the fire-insurance companies in the city, concludes as follows:—

"The proposed method of projecting water upon fires would greatly reduce the cost of that service as administered at present, and at the same time vastly add to the efficiency of the means of extinguishing by the application of water. First, it would enable a few men with a light hose-carriage to reach the point of fire much quicker than the present heavy engines to-day; and at the breaking-out of a fire a minute is sometimes worth a million dollars, and frequently a hundred thousand. Second, it would enable the firemen, by the use of permanent stand-pipes, to connect short lengths of hose, and apply the water in large streams and solid masses; whereas at present, even when two or three engines are forcing water through a single pipe, or tower, the stream is largely converted into spray before it reaches the fire, and is then converted into steam, and even into a gas that aids combustion rather than stops it."

The medical authorities and health-officers of this city have given this plan much careful consideration, and their conclusions are favorable to the project. Mr. James C. Bayles, president of the Board of Health, in a communication to Mr. Bartlett, gives his views as follows:—

"It is undoubtedly true that at the present time large portions of New York are very inadequately supplied with water. This department has constant and serious trouble in that branch of its work which deals with the plans of tenement-houses and other dwellings, owing to the fact that the available supply of water is in many cases so small as to forbid a proper cleansing of plumbing fixtures, if these are provided. There are large districts of the city where the pressure rarely carries the water above the first story; and in the case of tenement-houses, divided into many apartments, each apartment must be provided with one or more pumps, which, finding their supply from the three-fourths-inch tap at the street-main, are not always able to lift the water required for domestic use. A good water-supply, abundant in quantity and excellent in quality, is a condition precedent to the healthfulness of a community. This is especially true of a crowded community like New York. I am of the opinion that no one thing would do so much to facilitate and make effectual the work of this department as a great and immediate increase in the water-supply, under pressure sufficient to reach the upper stories.

"I am unable to favor, from a sanitary point of view, the measures which have been suggested, looking to a restriction of consumption in order to prevent the present admitted large waste. A liberal use of water accomplishes what can be attained in no other way,—the cleansing of pipes and sewers; and people who have access to all the water they desire and can use, are likely to be cleaner in their homes and persons than those who suffer restrictions in this most important item of daily consumption. I do not think the sanitary aspects of the question with which we are now confronted, growing out of an admitted scarcity of water in New York, can be exaggerated.

"An increased supply and better distribution of water in New York would undoubtedly tend to diminish the number of contagious and infectious diseases with which we now have to deal, and would produce a marked improvement in the public health. If it were not for its peculiar position as the gateway of this continent, to which more than eighty per cent of the inflowing travel and immigration tends, our death-rate would not be so large as it is. For example: if the deaths among immigrants who have never become a part of our population could be eliminated from our totals, we should last year have reduced the death-rate per thousand from twenty-four or twenty-five to twenty-two. If, further, we could avoid the overcrowding of Italian and other impoverished immigrants in our tenement-house districts, our death-rate would compare favorably with that of the most healthful city of the world.

"It will not do, however, to attach too much importance to these hopeful figures. They are liable at any time to be changed, and nothing will tend so quickly and effectually to change them as a failure in the water-supply of the city. Of the dangers to which this is subjected, I do not need to tell you.

"Answering your question with reference to the effect which an increased water-supply would have in diminishing the number of malignant diseases of a contagious or infectious type, I regret that I am unable to be specific. This, of course, is largely a matter of

opinion, but it is an interesting fact that a very large proportion of the cases of contagious and infectious disease which come under the care of the Board of Health are taken from the upper floors of tenement-houses. Whether this is due to lack of water, which is greatest on the upper floors, or to impurities in the water which rise to about that level, I am unable to say. I believe, however, that a material increase of the city's water-supply would promptly and permanently reduce the public burdens entailed in the care of the city's sick.

"The cordial sympathy and co-operation of this department would be extended to any practicable scheme looking to a supply of water for New York from other sources than the Croton watershed. Our city is growing with great rapidity, especially in the 23d and 24th wards, north of the Harlem River. It is probable that the needs of this district will not be more than met by the increased supply to be obtained through the new aqueduct, when all the engineering work looking to the impounding of additional water is completed."

If more need be said upon the subject from a sanitary standpoint, it is furnished by the following preambles and resolutions adopted by the Medical Society of the State of New York at a meeting held Sept. 24, 1888:—

"Whereas the present scarcity of water in this city is causing great inconvenience as well as serious apprehension for sanitary and other reasons; and

"Whereas the new aqueduct will not materially increase the present supply from the Croton watershed until after the storage-reservoirs are completed, six or more years from now; and

"Whereas the upper portion of the city, with its rapidly growing population, will soon require all the water that can be procured from that source; and

"Whereas the present insufficient supply of water is a constant menace to the health and safety of the city, inviting scarlet-fever, diphtheria, cholera, and other malignant diseases, as well as disastrous conflagrations: therefore be it

"Resolved that this society has listened to the explanation of the plans proposed by John R. Bartlett, Esq., for furnishing the city of New York with an additional supply of pure water, from a source independent of the Croton watershed, and that it approves the same, and urgently recommends it to the attention of the city authorities having such matters in charge."

PRUNES IN FRANCE.

THE introduction of prunes into France is attributed to the Crusaders, says our consul at Bordeaux; and, if tradition is exact, this valuable fruit was first cultivated in the south-west of France by the inmates of a convent near Clairac. In travelling from Avignon to Fumel, through the valley of the Lot, fertile plains are seen covered with plum-trees, which furnish the famous *prunes d'Ente* and *Robe-Sergent*, these being exported to the remotest corner of the commercial world. The plum-tree does not confine itself to this particular district of France, but it is profitably cultivated in the valley of the Loire, the departments of the Garonne, Dordogne, Tarn, and Aveyron. The well-known brand called 'Tours' prunes comes from the orchards of the Loire. Lorraine produces a variety called *Quetsche*, one of the best for ordinary preserves.

The prune-tree thrives best in clayey, calcareous soil, and does not exact for its roots a loam of profound depth. Land adapted to the culture of the vine is also partial to this tree. In many localities these two valuable products are cultivated together, as the broad leaf of the vine is especially useful in protecting the roots of the tree from the intense heat of summer. When the prune is ripe, it is covered with a sort of glaucous powder called "flower," which greatly adds to its value as a table-fruit. The fruit is usually gathered after the heat of the day has dissipated the humidity of the night, and, when possible, straw is spread beneath the trees to prevent the fruit coming in contact with the earth. Only such fruit as readily falls when the tree is slightly shaken is gathered. As soon as harvested, the fruit is taken to a building, where it remains for a few days to complete maturity.

Prunes are subjected to not less than three, and frequently to four, distinct cookings before being pronounced ready for market.

The first two preliminary cookings have for their object the evaporation of water contained in the fruit, and preparation for the final cooking, which dries the fruit and imparts a certain brilliancy much sought after by buyers. In several districts of France, most primitive means are practised in curing the fruit for market. In Provence freshly gathered fruit is plunged into pots of boiling water, where it remains until the water again arrives at boiling-point. It is then removed from the boilers, placed in baskets, and gently shaken until cool, when it is placed on long trays and exposed to the heat of the sun to complete desiccation. At Digne the prunes are not gathered until completely matured. Women peel the fruit

and cumbersome, and very primitive in their construction, only consisting of a frame to which is fastened a wicker-like bottom fashioned from rushes or willow twigs. They hold from twelve to eighteen pounds of green fruit, representing about four to six pounds of prunes. Care is taken, in preparing the oven for the first cooking, that the degrees of heat shall not exceed 50° C.; and in the second, 70° .

After each cooking, which occupies about six hours, the fruit is removed from the oven and exposed to the air. When the prunes are cold, they are carefully turned by women specially charged with this duty. They avoid disturbing the fruit while it is warm, as the

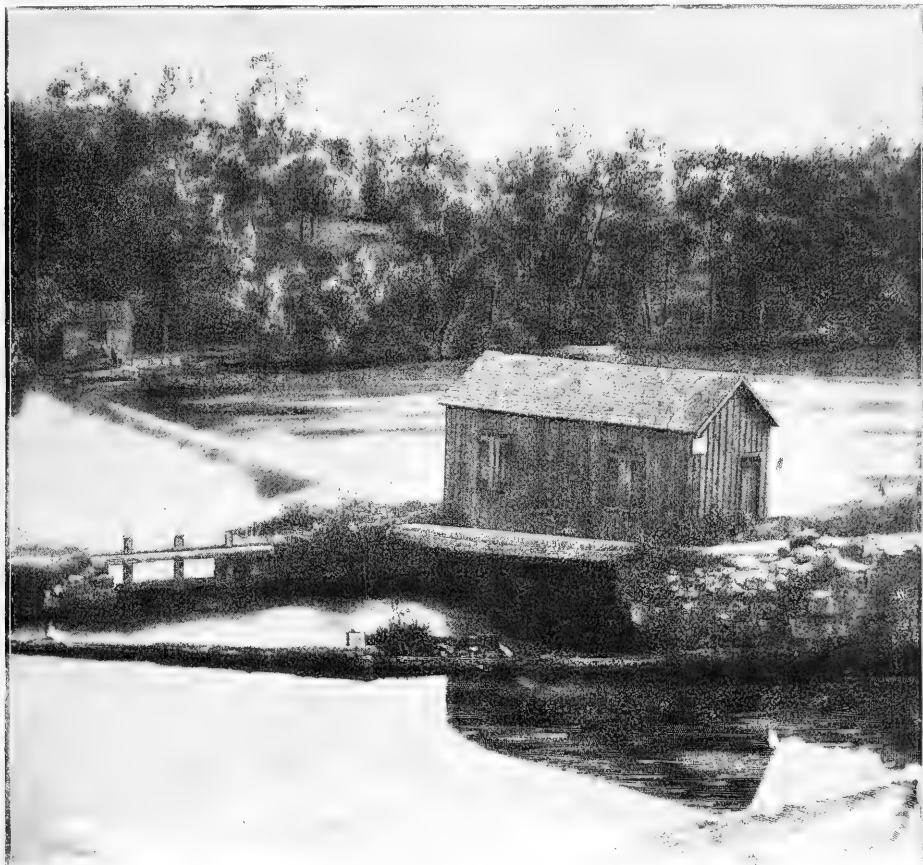

THE ROCKWAY RIVER AT THE BOONTON FALLS, SHOWING INTAKE OF THE MORRIS CANAL (ELEVATION ABOVE TIDE-WATER ABOUT 565 FEET).

with their nails to avoid injury to the soft pulp. The fruit is strung upon small twigs, and in such fashion as not to touch. These sticks of prunes are stuck into straw frames, which are suspended in the sun until the prunes easily detach themselves from the stick. The pit is then removed, the fruit placed upon trays exposed to the sun, and, when thoroughly desiccated, packed for market. In the departments of Indre-et-Loire and Lot-et-Garonne, immense ovens, specially constructed for prune-cooking, are used.

Most prunes are subjected to a preliminary washing to free them from dust or sand. After washing, the fruit is exposed to the sun or air on beds of straw, or on the trays on which it is cooked, to rid it of all humidity. When dry, it is spread in a single layer on the tray, and at once submitted to the oven. The trays used are made during the winter months by peasants. They are clumsy

touch renders it glutinous and prevents the fruit from congealing. The third cooking is performed at a temperature of 80° to 90° , and occasionally at 100° . After the third cooking, the prunes are sorted, and such as are found imperfectly cooked are again submitted to the oven. The degree of perfection in cooking is obtained when the fruit presents a dark purple color, solid and brilliant surface, malleable and elastic to the touch, and when the kernel is well done and intact in the shell. When these conditions are not obtained, the kernel ferments, and alters the entire prune, which very soon becomes mouldy and worthless.

Prunes are divided into nine categories, and are classified as follows: No. 1 represents 90 to 92 to the pound; No. 2, 80 to 82; No. 3, 70 to 72; No. 4, 60 to 62; No. 5, 55 to 56; No. 6, 44 to 45; No. 7, 40 to 41; No. 8, 34 to 35; and No. 9, 30 to 31. When ready

for exportation, the fruit is pressed flat between two cylinders covered with India-rubber, and then packed into cases by a special machine, called a "packer." Many dealers still perform this operation in the primitive manner of foot-pressure. Bordeaux is the principal centre of their industry, which is yearly increasing.

Besides the large amount of prunes exported to European countries by rail, there are, says Consul Roosevelt, about one hundred vessels annually leaving the port of Bordeaux loaded with this produce. In the beginning of the prune-industry, many devices were employed for their proper conservation. The first ovens were very primitive, and the work of preparing the fruit for market laborious. At present there are many different kinds of ovens in use, possessing more or less distinct features, but almost the same in general principles. The most generally used are the Bournel and

We also give a view taken from a photo of the Asheville, N.C., Electric Railway.

Asheville is a flourishing mountain town, noted throughout this country as a health-resort; and it is characteristic of such a town and its enterprise that it now has an electric railway, first-class in all particulars, which gives the people perfect and comfortable means of transit to the depots and hotels, and replaces the old springless hacks and primitive omnibuses.

The picture shown is from a photo taken shortly after the opening of the road, and represents three of the Sprague electric cars turning a corner into the main street of Asheville, N.C.; and it is an interesting feature to notice that it is difficult to discern the overhead system at all, on account of the smallness of the wires.

Besides an equipment of passenger street-cars, this electric rail-



ELECTRIC RAILWAY AT STEUBENVILLE, O., CAR PASSING UNDER RAILROAD-BRIDGE.

the Marletean ovens. The only ovens in use are of French manufacture.

SOME NEW ELECTRIC RAILWAYS.

THE accompanying engraving is from a photograph representing one of the Sprague electric cars in operation at Steubenville, O., passing under a railroad-bridge on the route of the road. The picture gives a very good idea of the wide range of movement of the trolley-arm, which can reach from 12 to 14 feet above the car, to less than 1 foot, when the location of overhead wire demands such a wide change. The kind of trolley-pole used upon this road is light and unobtrusive, consisting of a light, hollow iron rod carried on top of the car, and supported from the car by a stout steel spring, which allows it to move in every direction necessary.

The equipment of this road includes the regular Sprague system of overhead wiring, with main and working conductor running parallel, connected at intervals of every 100 to 200 feet. The road has been a success from the start, and has been visited by many street-railway managers from Ohio, Indiana, Kentucky, and western Pennsylvania.

way also possesses several freight-cars, also operated by electric motors of the Sprague type; and, as this road connects the depot of the North Carolina Railroad with the city of Asheville, these freight-cars have proved a convenience and a source of income.

THE SUBMARINE BOAT "GYMNOTE."

WE have already given some details of the "Gymnote;" but the following, taken from *Industries*, gives some additional information as to her construction. After the first trials of the "Gymnote," it was found that various details required modification, but on the whole the trials were satisfactory; and, now that the improvements which the first trials indicated to be necessary have been made, the French Government have accepted the "Gymnote" as the standard type of submarine vessel for offensive purposes. The hull is spindle-shaped, 6 feet in diameter by 56 feet long, provided with horizontal and vertical rudders, and with a cylindrical conning-tower of somewhat novel design. The conning-tower consists of a fixed tube, within which slides a second tube, carrying at its upper end a mirror inclined at an angle of forty-five de-

grees. When the inner tube is pushed right out, and the boat is floating near the surface, only the top of the telescope tube need be above the water; and the captain, standing within the boat, by glancing upward, can see in the mirror what is going on in front of him, or, for the matter of that, all around him, if the inner tube be revolved. By means of this ingenious application of a telescopic conning-tower with a mirror, the size of that part of the vessel which must project above the water-level to permit of an observation being taken, has been much reduced, as compared with the old plan of making the conning-tower large enough for the captain's head and shoulders to enter. In the stem of the vessel is fixed the torpedo-launching tube, and in the stern the electric motor by which the propeller is driven. There are various water-ballast tanks by which the vessel is trimmed, and access to the in-

distance that the boat could travel with one charge would be about 120 knots.

While the "Gymnote" is a boat mainly intended for the discharge of torpedoes against the enemy's ships, a second and much smaller submarine boat is now being built, the mission of which will be to render the enemy's submarine mines harmless by cutting their cables. This boat is also spindle-shaped, but only 15 feet long by 5 feet 3 inches in diameter, and will have a crew of two men only, whereas the crew of the "Gymnote" is from six to eight men. As the cubic capacity of this boat is comparatively small, compressed oxygen is to be carried as part of the equipment. The boat is to be provided with powerful scissors, working from inside, by means of which it is intended to cut the electric cables of the submarine mines. The screw is mounted on a swivel-shaft to fa-



VIEW OF ELECTRIC ROAD AT ASHEVILLE, N.C.

terior is afforded by a man-hole a little forward of the conning-tower. The power for working this vessel is derived from a battery of 564 Commelin & Demazures alkaline accumulators, weighing, in working order, close upon 10 tons. A compound switch is provided by means of which the battery can be differently grouped; the combinations being 12 cells parallel and 47 in series for very slow speed, 6 in parallel and 94 in series for slow speed, 4 parallel and 141 in series for ordinary travelling speed, and 2 parallel and 282 in series for fast speed. The weight of the battery per horse-power is 83 pounds. The electric motor works the propeller direct without the intervention of any speed-reducing gear, and has been specially designed for this purpose by Capt. Krebs. It is a sixteen-pole disk machine, weighing 2 tons, and developing 52 horse-power at a speed of only 280 revolutions a minute. The armature is 40 inches in diameter, and the winding is such as to require only four brushes. The resistance of the machine is .16 of an ohm. At full speed, the motor is sufficiently powerful to propel the boat at a speed of 9 to 10 knots per hour; the capacity of the battery being said to correspond, under this condition, to about four and a half hours of work, which would take the boat over a total distance of 40 to 45 knots. At a speed of 6 knots an hour, the total

cillitate the manœuvring, and is worked by an electric motor driven by a battery of Schanscheiff primary cells. The boat is lighted by five small glow-lamps; and a small arc-lamp with a projector is also provided, the beams of light from which can be thrown forward through glass lenses fixed in the hull, so as to illuminate the water for a certain distance ahead, and thus make the work possible for which this boat is especially intended.

If this country is going to rely to a great extent on torpedoes as a coast defence, the recent improvements in submarine boats cannot but be of great interest to Americans. Congress recently appropriated a considerable sum for the construction of such a vessel, and, although nothing definite is known about the plans that will be adopted, yet it is understood that electricity will not be the motive power.

NATURAL GAS IN OHIO IN 1888.

A LATE number of the *American Manufacturer* has a careful review of the natural-gas situation in Ohio, by Professor Edward Orton, the State geologist, who says in effect that no important discoveries have been made in Ohio during the year 1888, though a

great deal of drilling has been going forward, and the productive districts remain as at the end of 1887, four in number; viz., the Berea grit, the Ohio shale, the Clinton limestone, and the Trenton limestone. The last-named stratum, which is both a gas and oil bearing rock in northern Ohio and central Indiana, is, excepting possibly the Bradford sand, the most important single source of petroleum and gas on this continent. The oil is still ranked as inferior, on account of the present difficulty of refining it; but there is no drawback to the gas, as is apparent from the following analyses, made for the United States Geological Survey:—

	Findlay.	Postoria.	St. Mary's.
Hydrogen.....	1.64	1.89	1.74
Marsh-gas.....	93.35	92.84	93.85
Olefiant gas.....	.35	.20	.20
Carbonic oxide.....	.44	.55	.44
Carbonic acid.....	.25	.20	.23
Oxygen.....	.39	.35	.35
Nitrogen.....	3.45	3.82	2.98
Sulphuretted hydrogen.....	.20	.15	.21
Total.....	100.00	100.00	100.00

The small fraction, one-fifth of one per cent, of sulphuretted hydrogen is held to be decidedly advantageous, as it affords a certain means of detecting leaks.

No place within the natural-gas belt has derived greater advantages from this fuel-supply than Findlay, where in November, 1884, it was first found that the Trenton limestone, at some places at least, contained stores of high-pressure gas. Since January, 1886, the population of the town has increased from 6,000 to 30,000. Although there are rolling-mills, chain-works, machine and edge-tool shops, etc., the principal industry is glass, 155 pots being used by the ten firms engaged in making window-glass, fine flint ware, and bottles.

This growth has been built up in Findlay, as in other towns, by giving free, or nearly free, gas to manufacturers, — a gift which in some instances has been supplemented by land and contributions to capital, either from the town or parties interested in real estate. Under these circumstances, the question of the continuance of the supply is a vital one. Professor Orton has contended that the supply is a stored one, and notwithstanding the reasonableness of the theory, in view of the exhaustion of all deposits of liquid hydrocarbons, the gas has been used most profusely for the rough work of founderies, rolling-mills, brick and tile works, lime-burning, and the like, until, a short time since, Findlay found itself short of gas. A new well was drilled in, and, on being shot, responded with a pressure in the open casing of from 38 to 40 pounds, equivalent to a yield of about 30,000,000 cubic feet per day. The famous Karg well, which has been the main reliance of the town for the past two years, was estimated to discharge 12,000,000 cubic feet.

This shortage of gas has led to an investigation, from which the professor concludes that none of the large wells in the field have flowed three years, practically unrestrained, without giving unmistakable signs of nearing their limit. In some cases oil invades them; in others, salt water. The smaller wells appear in some instances to have a longer lease of life than the great wells. In some of the town wells the original rock pressure has been reduced by about three-eighths, but in others it is claimed it is fully maintained, only more time is required for gathering. The area exhausted by a vigorous well is not yet determined, but it is thought that the central portion of Findlay is partially drained of its original supply. As the city has pledged itself to furnish many million feet of gas each day, great energy and sagacity will be required to maintain in full vigor the splendid industries now established, and insure the continued prosperity of the town.

What is predicted of the Ohio Trenton limestone gas-field may probably be asserted as to the 2,000 square miles of the field in Indiana, though, if wells yielding 30,000,000 cubic feet of gas per

day, equivalent to nearly 1,000 tons of coal, are to be found whenever a shortage occurs, there may be a longer lease of the industrial life of that region than a cursory reading of Professor Orton's article might lead one to infer.

THE DENISON MOTOR AND DYNAMO.

THE accompanying illustration shows the form of dynamo and motor now manufactured by Mr. J. F. Denison of New Haven, Conn. These machines do not differ in their construction much from that which experience has shown to be desirable, but the motors have some points worthy of special consideration.

An arrangement known as the Denison interlocking starting attachment is contained in the base of the machine, and is said to prevent any mistake in operating the motors. This attachment is

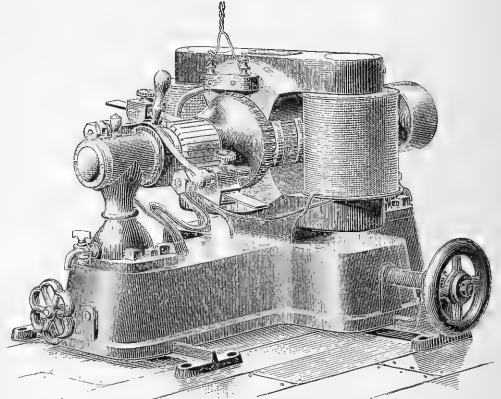

THE DENISON MOTOR AND DYNAMO.

so arranged that the current cannot be thrown on unless the resistance in the rheostat in the base is in the proper position. This is manipulated by a hand-wheel. In case of accidental breaking of the circuit, an automatic lock makes it impossible to turn the current on until the resistance is again in normal condition. The absence of attachments external to the machine, which are usually placed on the wall, the machine being entirely self-contained, does away with the expense of sending out special attendants to set it up. Further, as there are but two binding-posts, it is impossible to make a mistake in wiring.

HEALTH MATTERS.

Analysis of Foods.

THE commissioner of internal revenue of the United States has published the regulations concerning the analysis of foods and drugs in the District of Columbia. These regulations are based on the Act of Congress passed in 1888, entitled "An Act to prevent the Manufacture or Sale of Adulterated Food or Drugs in the District of Columbia." Section 12 of this Act provides that any health-officer, inspector of nuisances, or any food-inspector, may procure any sample of food or drug, and, if he suspects the same to have been sold to him contrary to any provision of the Act, he shall submit it to the commissioner of internal revenue to be analyzed. An offence shall be deemed to be committed in the case of drugs, if it differs from the standard of strength, quality, or purity laid down in the pharmacopœia, or falls below the professed standard under which it is sold. In the case of foods, the regulation gives a standard for butter, cheese, cocoa, chocolate, coffee, honey, lard, malt liquors, milk, mustard, olive-oil, oysters, pepper, tea, vinegar, wheat flour, bread, and wine.

A large number of coloring-matters are prohibited for use in foods. Among these are aniline, gamboge, fuchsine, naphthol yel-

low, and others. Salicylic acid and its salts are prohibited, as are also boracic acid and borax, glycerine, and alum. A list of harmless coloring-matters is given. The pamphlet also contains a list of periodicals, official reports, and general and monograph volumes of the greatest importance in connection with the detection of adulteration of food and drugs. This bibliography is exceedingly valuable, and, we should judge, very complete.

THE SURGEON-GENERAL AND THE NATIONAL BOARD OF HEALTH.—The "Annual Report of the Supervising Surgeon-General of the Marine Hospital Service of the United States for the Fiscal Year 1888," has just been published. It contains the customary statistics of this branch of the national service, and, in addition, a considerable amount of interesting matter in reference to the recent epidemic of yellow-fever in Florida, with photographic illustrations of the camps of refuge, and a map of Jacksonville showing the streets and sewers. It is much to be regretted that the supervising surgeon-general should, in an official report, have attacked the National Board of Health, and the excellent work which it did during the days when it had the power and the means. He charges Dr. Bowditch of Boston with "special pleading for a pet object," when, in September last, he expressed in a public letter the wish that a new birth might be granted to the national board with greater powers. The supervising surgeon-general speaks of this letter as being "ingeniously constructed," and further says that unfortunately the facts do not bear out the statements therein contained. If men of the standing and reputation of Dr. Bowditch can be thus attacked in governmental reports, we shall wish that some censorship may be established to which these reports shall be submitted before they are permitted to go forth with the official sanction.

TEMPERANCE INSTRUCTION IN PUBLIC SCHOOLS.—The report of the Department of Scientific Temperance Instruction in Public Schools for the year 1888 shows that twelve million children in this country are now under compulsory temperance education laws; that is to say, that the law has provided the education in favor of total abstinence that results from learning the nature and effects of alcoholic drinks and narcotics. This report further shows that there is no New England State without such a law; New Jersey is the only Middle State that has not enacted such a law; ten Southern and two Western States are still unprovided in that regard. The Act of Congress of 1886 brought all the Territories under the law. Those interested in this subject will find reports from the different sections of the country of the work done, and the difficulties to be met and overcome in States in which as yet compulsory laws have not been enacted.

DIPHThERIA AND SANITATION.—If the reports which the newspapers publish in reference to the sanitary condition of Gallitzin, Penn., are true, it is not a matter of surprise that diphtheria, once introduced, should prevail in epidemic form. In a population of only two thousand people, one hundred deaths from this disease are said to have occurred since November. The disease is attributed to the disregard of the common rules of sanitation. The town has no water-supply. The outhouses and wells stand close together, and, since the McCoy mines have been opened, over half the wells in the town have gone dry. The inhabitants have used water from the few remaining wells that have become impure. Fortunately there is an excellent State board of health in Pennsylvania, which will at once take the matter in hand.

ETHNOLOGY.

The Blackfoot Sun-Dance.

MUCH has been said regarding the barbarous dances of the Blackfeet and their neighbors, but the majority of reports have been made on hearsay. Therefore an authentic description of the ceremonies by an eye-witness, who is, moreover, thoroughly conversant with the native language, must be highly welcome to students of primitive man. The Rev. Dr. John McLean has presented such a description to the Canadian Institute of Toronto. It is one of the important results of the establishment by the British Association, of a committee for the study of the Indians of the Canadian

North-west, that missionaries begin to improve their opportunities of observing native customs, and of making available their studies of native languages.

The sun-dance is celebrated every summer. Last summer, when Dr. McLean visited the Blood Indian camp, he found the sun-lodge erected. There were by actual count one hundred and ninety-eight lodges, comprising about two thousand souls. An old man was riding through the camp, calling upon the people to attend the ceremonies. In a lodge near at hand, a medicine-man was decorating the persons who were to undergo the rite of torture. In arranging their head-dress, before putting it on, he passed his hand around it four times, praying. In the sun-lodge the sacred fire was burning, and this was used by the people for lighting their pipes. No child or woman was allowed to supply the fuel; but young men who had performed some valorous deed, especially the stealing of horses from a hostile tribe, felt it to be an honor to attend to this duty; and none but the brave are qualified for this work. On the sacred pole were placed, in the form of a cross, two bundles of small brushwood taken from the birch-tree. The pole was decorated with sacrifices to the sun of clothing and various kinds of Indian goods. The cross evidently refers to the four winds, from its four points, as does the number 4, which is regarded as the sacred number. In the bower made of light brushwood sat a woman who gave the festival that year, her husband, and a medicine-man. These persons were fasting and praying; and, during the full term of the continuance of the ceremonies, very little food was partaken of. In the mornings they were allowed a short smoke and a little water; and in the evenings a few of their friends brought a small quantity of food hidden under their blankets, and, without exposing it to view, it was eaten in silence. The medicine-man had a crown of leaves upon his head. His body was painted, and without any clothing, save a long strip around his loins. At short intervals he arose and danced, keeping time to the motions of his body with a small bone whistle, which he blew upon incessantly, producing a series of monotonous sounds. In the evening the woman prayed to the sun for good health for the people, protection in danger, good crops, and a bountiful harvest of wild fruits. The virgins came in the evening, and prayed for a long time for blessings from the sun. During the day the ceremonies consisted of dramatic representations of heroic adventures by single individuals, and contests with the Crow and Sioux Indians by war-parties. One chief borrowed several guns from his friends, and a large number of Indian war-instruments and native trinkets. Stepping forward that all the people might see him, amid profound silence, he addressed the assemblage. Holding a gun aloft, he told how, in a contest with an enemy, he had slain him and taken his gun. The band of musicians beat on their tomtoms in token of applause. Each article that he had represented his various victories, and each had its separate story, which was narrated at first, and the same routine gone through. When he had finished, the whole assemblage joined the musicians in applauding the speaker. Many warriors during the day related their brave deeds in the same manner.

Sham-fights were engaged in, which were representations of actual battles. Five or six warriors appeared as Crow Indians, and the same or a less number were the Blood Indian warriors. A single horse represented that they had been on horseback, and this was decked in its war-paint. One of the men, the hero of the battle, acted as instructor of the ceremonies to the others. Four times they entered the lodge, and then the fight began. They fired their guns over the heads of the people; the Crow Indians fell one by one; and when they had been scalped, amid the laughter and applause of the audience, the scene was at an end. Berries cooked in fat were brought in by the women in pails and pots; and for a short time eating, smoking, and conversation were the duties of the hour. Occasionally some old lady would call out the name of a young man, and declare his noble qualities before the people; and another would urge the young men to emulate the heroic deeds of their fathers, and go to war.

Presents of bracelets, finger-rings, and ear-rings were made to some of the women. The chief warrior carried in his hand the sacred pipe, which he first held aloft with the stem toward the sun, that he might have the first-fruits of every thing; and still holding it,

stem toward the chiefs, each was allowed to take a smoke. The pipe was beautifully ornamented, and was used only at the sun-dance. Some of these pipes are of great value, the one seen costing fifteen of the best horses in the tribe, and these were used for hunting the buffalo. The women have one important ceremony to perform; namely, the preparation of the tongues. In former years, when buffalo were in abundance, as many as two thousand buffalo-tongues were used at a single sun-dance: now the Indians have to be contented with two hundred tongues of domestic cattle. These are slightly boiled and dried, cut in slices very carefully, taken in sacks to the sun-lodge, and guarded by two young men. This rite partakes of the nature of a sacrament. None but virtuous women are allowed to go up and take a piece of tongue. After the persons devoted to the sun have partaken of the meal, the rest of the tongues are distributed among the people as a religious ceremony.

At this time a young Indian went to an old medicine-woman and presented his sacrifice to the sun. During the year he had gone on a horse-stealing expedition, and, as is customary on such occasions, had prayed to the sun for protection and success, offering himself to his god if his prayers were answered. He had been successful, and he now presented himself as a sacrifice. The old woman took his hand, held it toward the sun, and prayed; then, laying a finger on a block of wood, she severed it with one blow of a knife. She held the portion of the finger cut off toward the sun, and dedicated that to him as the young man's sacrifice.

One of the principal features of the sun-dance is the self-torture of those who are admitted as warriors. Dr. McLean witnessed one of these ceremonies. Two young men, having their whole bodies painted, wearing the loin-cloth only, and with wreaths of leaves around their heads, ankles, and wrists, stepped into the centre of the lodge. A blanket and a pillow were laid on the ground, and one of the young men stretched himself upon them. As he lay, an old man came forward and stood over him, and then in an earnest speech told the people of the brave deeds and noble heart of the young man. In the enumeration of his virtues and noble deeds, after each separate statement the musicians beat applause. When the aged orator ceased, the young man arose, placed his hands upon the old man's shoulders, and drew them downward, as a sign of gratitude for the favorable things said about him. He lay down, and four men held him, while a fifth made the incisions in his breast and back. Two places were marked in each breast, denoting the position and width of each incision. This being done, the wooden skewers being in readiness, a double-edged knife was held in the hand, the point touching the flesh, a small piece of wood was placed on the under side to receive the point of the knife when it had gone through, and the flesh was drawn out the desired length for the knife to pierce. A quick pressure, and the incision was made, the piece of wood was removed, and the skewer inserted from the under side as the knife was being taken out. When the skewer was properly inserted, it was beaten down with the palm of the hand of the operator, that it might remain firmly in its place. This being done to each breast, with a single skewer for each, strong enough to tear away the flesh, and long enough to hold the lariats fastened to the top of the sacred pole, a double incision was made on the back of the left shoulder, to the skewer of which was fastened a drum. The work being pronounced good by the persons engaged in the operation, the young man arose, and one of the operators fastened the lariats, giving them two or three jerks to bring them into position.

The young man went up to the sacred pole, and, while his countenance was exceedingly pale, and his frame trembling with emotion, threw his arms around it, and prayed earnestly for strength to pass successfully through the trying ordeal. His prayer ended, he moved backward until the flesh was fully extended; and, placing a small bone whistle in his mouth, he blew continuously upon it a series of short, sharp sounds, while he threw himself backward, and danced until the flesh gave way and he fell. Previous to his tearing himself free from the lariats, he seized the drum with both hands, and with a sudden pull tore the flesh on his back, dashing the drum to the ground amid the applause of the people. As he lay on the ground, the operators examined his wounds, cut off the flesh that was hanging loosely, and the ceremony was at an end.

In former years the head of a buffalo was fastened by a rope to the back of a person undergoing the feat of self-immolation, but now a drum is used for that purpose.

From two to five persons undergo this torture every sun-dance. Its object is military and religious. It admits the young man into the noble band of warriors, whereby he gains the esteem of his fellows, and opens up the path to fortune and fame. But it is chiefly a religious rite. In time of sickness or danger, or in starting upon some dangerous expedition, the young man prays to the sun for help, and promises to give himself to the sun if his prayers are answered. Upon his return, when the annual sun-dance is held, he fulfils his vow, gives himself to his god, and thus performs a twofold duty. Of course, the applause of the people and the exhibition of courage are important factors in this rite, but its chief feature is a religious one. Instead of being a time of feasting and pleasure, the sun-dance is a military and religious festival, in connection with which there are occasions for joy, and the feast enhances the pleasure.

During the feast the entire assemblage will burst forth in songs of thanksgiving, and again a famous warrior will sing aloud the praises of a young man or some brave kinsman who merits the applause of the tribe. This is a kind of chant, in which the name and noble deeds are spoken of.

A SURVIVAL OF CORPORAL PENANCE.—The state of mind from which the infliction of self-torture arises is not confined to primitive people, but has manifested itself in all great religions of the world. In the middle ages the Order of the Flagellants was devoted exclusively to this purpose. A survival of this once powerful organization offers an interesting comparison to the practices of the Blackfeet, just described. This was observed to exist by Mr. O. H. Howarth in the village of Fenaës d'Ajuda on the Azores, and has been described by him in a recent number of the *Journal of the Anthropological Institute*. The Order of the Ferceiros in that place now consists of a body of from fifteen to eighteen lay inhabitants of the parish, who are admitted to it by election every seven years; the order being held in such reverence, and the efficacy of the penance so profoundly believed in, that vacancies are much sought after. The ceremony takes place annually in connection with the procession of N. S. dos Passos on the third Sunday in Lent. The costume of the Flagellants is a white linen tunic, with a large oval opening in the back for the purpose of flagellation; and the head of the performer is entirely concealed with a wrapper of white linen, so that his identity may be unknown to the general spectators. Mass is conducted by the priest, and the flagellation commences when the church is darkened in the course of the Lenten ritual, the order kneeling in two rows at each side of the chancel. It is continued throughout the procession which follows. The principal streets of the village are traversed, and the self-punishment is inflicted with special violence during pauses at the street-corners, when the members of the band seem to vie with one another in the severity of their discipline. The procession returns to the church; the flagellants resuming their former position, and continuing to scourge themselves with increasing vigor until the conclusion of the ceremony. The torture is carried to such extremities that the side walls, railings, and confessionals in the chancel are smeared and spotted with blood to a height of four or five feet. The type of the scourge and flagellum are such that the author concludes the institution to be kept up by unbroken tradition from the middle ages, the implements being of the same description as those used six centuries ago by the Flagellants.

ELECTRICAL NEWS.

SMALL ENGINES FOR ELECTRIC LIGHTING.—The Society of Arts in England having offered a gold medal for the best small engine to be used for electric lighting, some tests have just been published giving the results of the trial. There were four competitors, — three gas-engines, and a high-speed high-pressure steam-engine. As the machines are especially useful for isolated lighting plants, the results give some valuable data as to the cost of lighting by electricity as compared with gas. One of the three gas-engines,

the Otto, is well known in this country. A mixture of gas and air is admitted into the cylinder and ignited, the explosion giving the motive power. The arrangement is such that the engine receives one impulse in every two revolutions; so, in order to get a steady motion, an extremely heavy fly-wheel, or a countershaft carrying a fly-wheel, is necessary. Another of the gas-engines, the Atkinson, is of rather remarkable design. There are four strokes of the piston to one revolution of the fly-wheel, and these strokes are of varying length. The stroke which takes the charge into the cylinder is 6.3 inches; the next stroke compresses the charge, and is 5 inches in length, the charge being thus compressed into a space of 1.3 inches. The compression being effected, ignition takes place, giving the working stroke, which is 11.13 inches in length. This is followed by the exhaust stroke, which sweeps the products of combustion out, and is 12.4 inches in length. The cylinder is 9.5 inches in diameter. The third of the gas-engines, the Griffin, differs from the other two in several particulars. An impulse is given to the crank-shaft for every revolution and a half. The tests were made by Professor A. C. W. Kennedy, Dr. John Hopkinson, and Mr. Beauchamp Tower. Taking first the Atkinson engine, they found that the gas consumed per indicated horse-power was 18.8 cubic feet, and per brake horse-power 22.1 cubic feet per hour. The gas used for ignition was 4.5 cubic feet per hour, making a total per brake horse-power of 22.6 cubic feet per hour. The engine ran smoothly and with regularity. The mechanical efficiency of the engine was 85 per cent, and 25.5 per cent of the whole of the heat generated was converted into work. The Otto engine used 27.4 cubic feet of gas per hour for an available horse-power. The Griffin engine used 28 feet per hour for an available horse-power. These figures show, that, as far as the cost of gas is concerned, it is more economical to use it to drive an engine, and use the power developed for electric lighting, than to burn it directly. For instance: if we take 25 cubic feet of gas per hour as the average amount consumed per horse-power by a gas-engine, then we have, by burning direct, 5 16-candle-power gaslights; with gas-engine and dynamo, 12 16-candle-power electric lights. There are at present, however, so many additional expenses incident to an isolated electric plant,—interest, depreciation, breakage, attendance, etc.,—that it is cheaper to use the gas directly. At the same time, the figures given suggest possibilities. The fourth engine tested was a Davy-Paxman steam-engine of about twenty horse-power. This gave some remarkable results. It is a compound engine, the cylinders being 5.24 and 8.93 inches in diameter, and the stroke 14 inches, the pressure used being 100 pounds. The result of one of the trials was an available horse-power for 2.08 pounds of coal per hour,—a remarkable result, considering the size of the engine. These results show, that, as far as cost of fuel alone is considered, a horse-power hour from a gas-engine, with gas at \$1.50 per thousand feet, would cost 3.75 cents; and from a Davy-Paxman engine, with coal at \$4 per ton, .8 of a cent.

ACCUMULATORS.—Judge Coxe has just rendered a decision in the United States Circuit Court for the southern district of New York, in which the Faure patent for improvements in secondary batteries or accumulators is held to cover any secondary battery in which an electrode is used having the so-called active material applied in the form of a paint, paste, or cement. The suit is entitled "The Electrical Accumulator Company vs. Julien Electric Company." The field for accumulators is very large, as shown by the fact that there are to-day no less than eight or ten companies engaged in that business. Among them are the Electrical Accumulator Company, owning the Faure patents, and the Julien, Gibson, Woodward, Pumpelly, and Macraon Companies, all of whose batteries, the Accumulator Company claims, are tributary to the Faure invention. In anticipation of a favorable decision, the Electrical Accumulator Company has already built a street-car to be propelled by means of batteries, and now has it on exhibition on Elkins & Widener's Philadelphia Traction Road in West Philadelphia. Its initial trip last Friday was a success, the car moving up a long five-per-cent grade at the rate of seven miles an hour. Brill & Co., West Philadelphia, are making six other cars to be completed in April and May; and the Electrical Accumulator Company is now prepared to occupy extensively the electric street-car field.

NOTES AND NEWS.

DR. R. W. SHUFELDT has moved from Fort Wingate, N.Mex., to Washington, D.C., where he will continue in his scientific pursuits at the Smithsonian Institution.

—The wind-pressure on the Forth bridge, or rather the effective area of a bridge exposed to a wind-pressure striking the work at different angles, was practically demonstrated by Mr. B. Baker, as described in a late lecture before the Society of Arts, as follows: a model of the bridge was made, and towed in water at different angles to the stream; the area of a flat board normal to the current was then determined, which exerted the same drag as the model; this area was then taken as the effective area of the bridge for the particular angle at which it was towed.

—M. Alfred Binet of Paris, France, will contribute to *The Open Court* (Chicago) of March 21 a paper on "Sensation and the Outer World." The article is part of an unpublished essay upon "External Perception," crowned by the Académie des Sciences Morales et Politiques. In the same number Professor Edward D. Cope of Philadelphia will present some considerations upon ethical evolution, including a review of the extent and significance of the utilitarian doctrine of morals. *The Open Court* of March 28 will contain an article by the German Sanscrit scholar, Professor H. Oldenberg, on the "Discovery of the Veda." The disclosures that this epoch-making event have led to, form the most interesting chapter in all philological science.

—The composition and evaporative power of Kansas coals have been investigated by Professor E. H. S. Bailey and Professor L. I. Blake, of the State University. The coal-measures that underlie the eastern part of the State of Kansas are being developed at the present time to a greater extent than ever before. With the increased population of the State, the introduction of important manufacturing, and the extension of so many lines of railway, there is naturally a greater demand for fuel, and a greater interest in its economic supply. In the last "Report of the State Mine Inspector" (1887), there are mentioned about a hundred shafts, in the different regions, where mining is actively carried on; besides this, there are innumerable places where coal is mined or stripped in a small way to supply the local trade. The coal-beds seem to be divided into several groups, the lowest being in the extreme south-eastern part of the State. The coals depreciate in their steam-producing powers from the south-eastern part of the State toward the north and west. Professor Bailey finds they depreciate in the amounts of fixed carbon in a similar order.

—The Johns Hopkins Hospital will be opened to the inspection of the public, before the reception of patients, during the week beginning May 6, 1889. On Tuesday, May 7, at 11 o'clock in the morning, there will be appropriate addresses in the main administration building. Invitations to be present will be sent to the authorities of the city and State, to those who have rendered special services in promoting the plans of the hospital, to professors of medicine and surgery, to the chief managers of other hospitals, and to the representatives of the press. On Wednesday, May 8, between the hours of 12 and 6 o'clock, the buildings will be open to the medical profession of Baltimore, Washington, and the State of Maryland, to medical students, to the managers of the benevolent institutions of Baltimore, to the ministers of all religious denominations, and to other persons whose pursuits have led them to take a special interest in hospital-work. Cards of admission will be distributed in advance. On Thursday, May 9, and Friday, May 10, between the hours of 12 and 6 o'clock, the public generally will be invited to visit the hospital. Cards of admission may be obtained, on the days named, at the entrance-gate of the hospital, Broadway. On Saturday, May 11, the faculties of the various institutions in Baltimore, the teachers of public and private schools of every kind, the students of the Johns Hopkins University, the Baltimore City College, the State Normal School, the Woman's College of Baltimore, and the Eastern and Western Female High Schools, will be admitted between the hours of 10 and 6 o'clock upon the presentation of tickets, which will be distributed in advance. The dispensary will be opened for the treatment of out-door patients, Monday, May 13, at 10 o'clock. The hospital will be opened soon afterwards for the treatment of patients.

SCIENCE:

A WEEKLY NEWSPAPER OF ALL THE ARTS AND SCIENCES.

PUBLISHED BY

N. D. C. HODGES,

47 LAFAYETTE PLACE, NEW YORK.

SUBSCRIPTIONS.—United States and Canada.....		\$3.50 a year.
Great Britain and Europe.....		4.50 a year.
Science Club-rates for the United States and Canada (in one remittance):		
1	subscription 1 year.....	3.50
2	" " 1 year.....	6.00
3	" " 1 year.....	8.00
4	" " 1 year.....	10.00

Communications will be welcomed from any quarter. Rejected manuscripts will be returned to the authors only when the requisite amount of postage accompanies the manuscript. Whatever is intended for insertion must be authenticated by the name and address of the writer; not necessarily for publication, but as a guaranty of good faith. We do not hold ourselves responsible for any view or opinions expressed in the communications of our correspondents.

VOL. XIII. NEW YORK, MARCH 22, 1890.

No. 320.

CONTENTS:

THE WATER PROBLEM OF NEW YORK.....	208	EDITORIAL.....	218
PRUNES IN FRANCE.....	210	Purity of Drugs.....	218
SOME NEW ELECTRIC RAILWAYS.....	212	THE ADIRONDACK FORESTS.....	212
THE SUBMARINE BOAT "GYMNOTE".....	212	THE UTILITY OF AGRICULTURAL EXPERIMENT STATIONS.....	219
NATURAL GAS IN OHIO IN 1888.....	213	THE ENCOURAGEMENT OF HIGHER EDUCATION.....	219
THE DENISON MOTOR AND DYNAMO.....	214	H. B. Adams	
HEALTH MATTERS.....		BOOK-REVIEWS.....	
Analysis of Foods.....	214	The Government of the People of the United States.....	222
The Surgeon-General and the National Board of Health.....	215	A Text Book of Elementary Biology.....	222
Temperance Instruction in Public Schools.....	215	Chemical Lecture Notes.....	223
Diphtheria and Sanitation.....	215	AMONG THE PUBLISHERS.....	223
ETHNOLOGY.....		LETTERS TO THE EDITOR.....	
The Black-foot Sun-Dance.....	215	Origin of Fish in Isolated Waters.....	223
A Survival of Corporal Penance.....	216	Chs. B. Palmer	223
ELECTRICAL NEWS.....		The Soaring of Birds.....	225
Small Engines for Electric Lighting.....	216	J. G. MacGregor	225
Accumulators.....	217	Shall We Teach Geology?.....	226
NOTES AND NEWS.....	217	The Reviewer	226
		Curves of Literary Style.....	A. B. N. 226
		Wind-Velocity and Wind-Pressure.....	H. A. Hazen 226
		Queries and Answers.....	227

DR. WILLIS G. TUCKER, analyst of drugs, has made his eighth annual report to the State Board of Health of New York. He has collected and analyzed 326 samples of drugs, and pharmaceutical chemicals and preparations. These include acetic acid, calomel, chloroform, ether, glycerine, iodoform, tincture of chloride of iron, lime-water, saffron (*Crocus*), santonine, and sulphur. Forty-three per cent were found of good quality; 13.5 of fair quality; and 24.2 of inferior quality; and 19.3 not as called for, that is to say, substituted articles, as, when saffron (*Crocus*) was asked for, common safflower was sold. Fifty-three samples of stronger ether were examined. Of these, 20 were of good quality, 5 fair, 26 inferior. One sample was spirit of nitrous ether, and another the so-called "concentrated nitrous ether." As Dr. Tucker says, such errors as these are the grossest of blunders, and the consequence of such ignorant or careless sales might be most serious to the purchaser. As stronger ether is used as an anæsthetic, it ought to be of good quality. If the samples examined by Dr. Tucker represent the true condition of affairs throughout the world, it is not surprising that evil results sometimes follow the use of ether as an anæsthetic, as his results show that more than 50 per cent of the ether he tested was of inferior quality. Dr. Tucker expresses the opinion that the work done during the past two years has had a decided effect in improving the quality of the drugs sold throughout the State.

THE ADIRONDACK FORESTS.

As the majority of persons are interested in the preservation of our forests in the East, the arguments of *Garden and Forest*, in its issue of March 6, in favor of State control, will probably meet with some response. It is hardly likely that the direful picture which the writer of the article would bring before our mental vision will be realized; since the State of New York varies little in its commercial environment from New England, and in New England the tree-covered area has been on the increase for fifty years. So, while the constant change from freshet to drought may never be the fate of northern New York, yet the primeval forests may be gone as a pleasure-ground. The editor of *Garden and Forest* argues as follows:—

The complete destruction of the Adirondack forests is inevitable if existing conditions and methods of treatment are to continue. Unimportant improvements in the details of their management may be made from time to time; such improvements have been made within the last few years, and others are now proposed; but the processes of destruction are much more rapid and extensive than the effect of these comparatively insignificant means of amelioration, and there is at present no reason to expect that any effective provision will be made for the permanent protection of any part of this important region. Nothing can be done, indeed, without a thorough change in the system of control and administration of the forests on the State lands. The methods now pursued interpose no serious check to the influences which will extirpate the woods in a comparatively short time. If the devastation of the region, already far advanced, is completed, centuries of time will be required for any process of restoration.

The destruction of the North Woods will produce a change in the flow of the principal rivers of the State, and in the water-supply of the Erie Canal, which will cause widespread disaster to the interests of the people. There will be uncontrollable freshets at the times of heaviest rainfall, and when the snow melts in the spring; the channels of the rivers will be choked by *débris* brought down from the hills; and in summer, when a full volume of water is most needed, the flow will be insignificant. If this ruin is consummated, it will be a most serious blow to the prosperity of the State and of all classes of its people.

Not less important is the value of the region, in its relation to the health and life of the people of the country, as a place of resort for the inhabitants of the towns, and for all who need the restorative and vitalizing atmosphere and influences of a region of sylvan beauty and peace. As our population becomes more dense, the need and value of wild, rough tracts, incapable of cultivation, will be greatly increased. Beyond the arrangement required for the subsistence and comfort of the multitudes of visitors, no settlement or inhabitation should be permitted in any part of the wilderness. If the forests are destroyed, the entire charm and attractiveness of the region will be eliminated, and a scene of hideous desolation will be substituted which no one will ever wish to look upon.

The only plan by which such injury can be averted, and means provided for the permanent conservation of these invaluable forests, is the acquisition by the State of the entire Adirondack region. While portions of it remain in the hands of private owners, injuries to State lands adjacent to their holdings cannot be prevented. But it would be senseless and wicked to expend the money which would be required for this purpose while the present system of control continues. It has proved entirely inadequate for the protection of the forests on the lands which already belong to the State, and it would be the extreme of folly to acquire property at great cost when there is danger that it might soon be dissipated and destroyed.

Unless a system of permanent control, under competent direction, can be put in operation, the people of New York may as well relinquish all thought of saving the Adirondack forests, and all interest in the subject. There can be no adequate or successful administration of a great forest-preserve while its management is subject to the possibility of frequent change, because it is treated as a portion of the political patronage of the State government. Unless the care of the forests on the State lands can be placed in the hands of men of such known and obvious character and quali-

fication for this work as will inspire general confidence, no system of administration can be successful, and competent men will not accept a place of such responsibility and importance while their work is always liable to interruption by the agencies of partisan politics. The inadequacy and failure of the present system of control and administration are inherent in the system itself, and are inseparable from its relation to partisan change and caprice. The evil is not to be remedied by merely changing the persons who administer a system which is essentially vicious.

If the people of the State of New York have enough regard for their own interests to lead them to insist upon the adoption of a system embodying the essential features of competent direction and security from partisan interference, it will be safe and wise to acquire the whole Adirondack region by purchase. If they have not this perception of the importance of the object in view, and of the means which are necessary for its accomplishment, the forests will be left to their fate. The methods now employed are wholly useless and ineffective.

THE UTILITY OF AGRICULTURAL EXPERIMENT STATIONS.

The Hon. W. W. Wright, in a recent address on the past and present work and future prospects of the Geneva station, New York, took occasion to uphold the usefulness of such stations. The establishment of an experiment station by the State near Geneva within the last seven years challenged a great deal of curiosity among farmers and others, and is of late creating more and more of interest. To most people it was entirely new, nothing of the kind being nearer than adjoining States; and it may be said to be a modern invention, but cannot be called a "Yankee contrivance," for England, France, Germany, and other European countries, led off in the creation of these establishments within the present century, and had expended many millions of dollars in their organization and maintenance before any of the American States had established one. New York was among the last to avail itself of these institutions, though its wealth, extent of territory, and diversified agricultural interests, would naturally have made it the first. In one sense, such a "station" is no "experiment." In its organization, management, and the results to be expected, we have only to look to other civilized countries, which have had an experience, in some cases, of nearly forty years. When the Legislature of New York passed the law for creating this station, the significant fact was before us that neither in this country, nor in any other, had these stations been established, except they had fully answered the expectations of their projectors, and had been cherished and sustained, because their benefits were so manifest that there was no hesitation about continuing appropriations for their maintenance. Agricultural colleges, and classes in universities in which scientific farming was taught, were established or endowed in New York, but they cannot be said to have been successful. The most extensive of them was totally abandoned after a few years; whereas no experiment station has ever been discontinued, or diminished in the scope of its work, or embarrassed in the want of funds, in this country or Europe. On the contrary, in foreign countries they have been multiplied to an enormous extent, and have steadily increased on this side, though not so rapidly. There must be some reason for the success of these stations, and the total or partial failure of the colleges. The truth is, they are both schools, in which there is little difference in the abilities and qualifications of the teachers, but there is a vast disparity in the number and character of the students. In colleges we teach a few hundred boys, only a small percentage of whom will become practical farmers; while the stations are endeavoring to teach the same science to a whole community of men of all ages and conditions, engaged in the business of agriculture, not alone through lectures in which the relations of science and practical farming are explained, but through the agricultural press, and pretty much all newspapers now published and circulated in this country, daily, weekly, and monthly; and these are supplemented by bulletins giving in detail appropriate facts and statistics of the greatest interest to those who desire to become better informed in a business which occupies their constant thoughts, and in most cases the labor of their hands.

Through these channels the stations reach the whole agricultural community. Nobody is too illiterate to participate in this knowledge, if he can read, or understand what others read to him. Nobody is too old to learn in this "school;" and he soon becomes almost unconsciously a teacher himself, for he imparts the knowledge he has thus acquired to others, in farmers' clubs and neighborhood gatherings, in the village tavern or post-office, at the country firesides, in the fields and on the highways, in an unpretentious but none the less effective and valuable way. He tests the theories of the professors, lecturers, and newspaper-writers by his invaluable practical knowledge and common sense, and often detects the errors into which theorists are always liable to fall, and thus renders valuable service to the true interests of agriculture. It may happen in this way that men who have never learned to read or write, but are capable of managing a farm well, may become valuable teachers in a limited sphere.

The first agricultural experiment station was established in Germany in 1851, and since that time the number of stations has steadily increased, until at present the number in the German Empire alone is given as 184. Careful statistics, including nearly every country of Europe, show that if New York should expend an equal amount, proportioned to the area of our territory, we should expend one million dollars annually. If, on the other hand, it were proportioned to our population, it would require an annual expenditure of three hundred thousand dollars before we should be on a level with the countries of Europe. The first station, as has been stated, was established in 1851 at Moeckern in Saxony; five years after, there were 6 stations in existence; five years later, 15; in 1866, 30; and in 1871, 56; since which time they have been even more rapidly increased.

Those who may perhaps regard the work done at Geneva as rather of scientific than practical value will be gratified to learn what work was entered upon and continued at this first station at Moeckern during the first six years of its existence. This is given in a summary recently prepared, comprised under twenty-six different heads. We select but a few of them: 1. Feeding-trials with sheep to ascertain the best maintenance rations; 2. Feeding-trials with cows, showing effect of colesseed-cake on yield of milk; 3. Feeding-trials on fattening sheep; 4. Observations on the yield of manure of cows and sheep, and the changes it suffers by keeping; 5. Comparison of feeding-value of grass, hay, and aftermath; 6. Observations on milk-production in passing from winter to summer feeding; 7. Effect of lupines on milk-production; 8. Composition and value as food of various kinds of distillery and brewery waste; 9. Feeding-trials with cows, oxen, and calves, the proper proportion of nitrogenous and non-nitrogenous food-elements for the three classes of animals, etc.

THE ENCOURAGEMENT OF HIGHER EDUCATION.¹

THE choice of the 22d of February for the founder's day of the Johns Hopkins University will always be recognized as singularly appropriate. Historic associations, at once local and national, determined the choice.

It is a fact not generally known that the Father of his Country, before he became President of the United States, was the president of a Virginia college. When Washington was chosen to the office of chancellor of William and Mary College, succeeding the Bishop of London in that educational honor, he assured the board of trustees of his firm confidence "in their strenuous efforts for placing the system of education on such a basis as will render it the most beneficial to the State and the republic of letters, as well as to the more extensive interests of humanity and religion." Washington was always the friend of William and Mary College, his *alma mater*. Without forgetting local institutions in Virginia, he advanced during his eight years' presidency of the United States to what may be called the national idea in university education. From that idea Baltimore to-day can derive encouragement and inspiration.

Washington's grand thought of a national university, based upon individual endowment, may be found in many of his writings, but

¹ Abstract of an address by Professor Herbert B. Adams, Johns Hopkins University, Feb. 22, 1889.

the clearest and strongest statement occurs in his last will and testament. There he employed the following significant language: "It has been my ardent wish to see a plan devised, on a liberal scale, which would have a tendency to spread systematic ideas through all parts of this rising empire, thereby to do away local attachments and State prejudices, as far as the nature of things would, or indeed ought to admit, from our national councils. Looking anxiously forward to the accomplishment of so desirable an object as this is, in my estimation, my mind has not been able to contemplate any plan more likely to effect the measure than the establishment of a university in a central part of the United States, to which the youths of fortune and talents from all parts thereof may be sent for the completion of their education, in all branches of polite literature, in arts and sciences, in acquiring knowledge in the principles of politics and good government, and, as a matter of infinite importance in my judgment, by associating with each other, and forming friendships in juvenile years, be enabled to free themselves in a proper degree from those local prejudices and habitual jealousies which have just been mentioned, and which, when carried to excess, are never-failing sources of disquietude to the public mind, and pregnant of mischievous consequences to this country. Under these impressions, so fully dilated, I give and bequeath, in perpetuity, the fifty shares which I hold in the Potomac Company, . . . towards the endowment of a university, to be established within the limits of the District of Columbia, under the auspices of the general government, if that government should incline to extend a favoring hand towards it."

Here was the individual foundation of a national university. Here was the first suggestion of that noble line of public policy subsequently adopted in 1846 by our general government in relation to the Smithsonian Institution. The existence and ever-increasing prosperity of the Smithsonian Institution are standing proofs that private foundations may receive the fostering care of government without injurious results. Independent administration of scientific institutions may co-exist with State aid. It is a remarkable testimony to the wisdom of George Washington's original idea, that Andrew D. White, who, when president of Cornell University, happily combined private endowments and government land-grants, lately suggested in *The Forum* (February, 1889) the thought of a national university upon individual foundations. This thought is a century old, but it remains to this day the grandest thought in American educational history.

George Washington, like James Smithson, placed a private bequest, so that the general government might extend to it "a favoring hand;" but in those early days Congress had no conception of the duties of government towards education and science, and unfortunately the Potomac stock never paid but one dividend. George Washington's educational schemes were by no means visionary. His stock in the James River Company, which, like the Potomac Company, he had helped to organize, actually became productive, and was by him presented to Liberty Hall Academy, now Washington and Lee University. Washington raised Liberty Hall Academy to what he called "a seminary of learning upon an enlarged plan, but not coming up to the full idea of university." He meant to make it one of the three Virginia supporters of the university at Washington. Liberty Hall, or Washington College, his own William and Mary, and Hampden-Sidney, were all to be state pillars of a national temple of learning.

Was it not in some measure an historic, although an unconscious, fulfilment of that old dream of Washington, when, a hundred years later, Johns Hopkins determined to establish upon the Maryland side of the Potomac a university? Doubtless Johns Hopkins, like George Washington, had no very definite conception concerning the world-wide relations of a great modern university; but he saw as clearly as did the Father of his Country that the beneficent influence of higher education, if properly endowed, must reach far beyond the limits of a single State.

The Baltimore public has been accustomed to see or hear some new thing every year with regard to the number of students from this city, from Maryland, Japan, and each individual State of the American Union. The following facts represent a novel grouping of students according to the great sections of country from which they come. There have been some misapprehensions in our com-

munity concerning the region benefited by this university. Our new arrangement of statistics shows that during the present year there have been studying at this institution 98 graduates from the South, 47 from the West, 26 from the Middle States, 18 from New England. It is plain that this university is drawing college-men from the same sources as those from which Johns Hopkins drew his wealth; namely, from the South and West. In the undergraduate department there are now 139 students from the South, 18 from the West, 14 from the Middle States, and 4 from New England. Plainly, most of "our boys" come from the same sections of country as our graduates. The sum total of men from the South is 237; from the West, 65; from the Middle States, 40; from New England, 22. In short, the South has more than three and one-half times as many representatives as the West, six times as many as the Middle States, and more than ten times the number from New England. The total number from all the other States combined is nearly doubled by the South. About one-half of our entire student public comes from the State of Maryland. Considerably more than one-half comes from the three Southern States which Johns Hopkins wished especially to benefit. From this brief review of statistical facts, four points are clear: first, the intent of our founder has been realized; second, the South and the West are chief sources of our student-supply; third, in these directions are the lines of least resistance and greatest influence for the Johns Hopkins University; fourth, one-half of our student public comes from other States than Maryland,—a fact indicating that the local idea is happily balanced by the national idea.

There are pleasing evidences of internationality in the life and influence of the Johns Hopkins University. Some of our professors came hither from England and Germany. Almost all the members of our faculty have studied at one time or another in European institutions. The annual register for 1888 shows twelve students from Canada, seven from Japan, and one representative from each of the following countries: China, England, Germany, Mexico, Italy, and Russia.

Of the graduates, we see Westerners called eastward to college positions, Northerners called southwards, and Southerners called northwards. The president and trustees of the Johns Hopkins University have established here a national university upon a local and individual foundation.

How can the foundations of a national university, resting upon individual endowment, be further strengthened? Simply by extension and more endowments of the same sort. A great university grows, as a great city grows, by the individual association of property investments along avenues already opened. There are men who dream of founding towns and universities apart from existing centres of population and capital; but he is a wise founder who, like George Peabody, Johns Hopkins, or Enoch Pratt, recognizes the vantage-ground of a noble city, and plants there institutions which will work together through coming ages. The principle holds with reference to individual endowments for the higher education. They always accomplish the most good when they are connected with some central foundation which gives them at once stability, unity, and individuality, as in the associated institutions of a large city.

Extension by private philanthropy is the manifest destiny of the Johns Hopkins University. There will perhaps be the individual endowment of a college; perhaps of a university library, bearing the name of the giver, like the Andrew D. White Library at Cornell University; of a laboratory, a museum, or an observatory, like those at Harvard or at the University of Virginia. Some day we ought to have an art-gallery like that at Yale. What is most needed, however, is a central academic building and library to shelter fitly the "fair humanities,"—the studies of ancient and modern literature; philosophy and ethics; history, politics, and social science. Baltimore, in the course of time, will have as many foundations, bearing individual names, as there are now in the older institutions of the country. Glance through the catalogues of Harvard, Yale, Princeton, or the University of Virginia, and see the great host of private bequests, some large, some small, but all of them carefully guarded and applied to specific objects, such as the increase of the library or the support of scholarships and fellowships. There may be as much individuality in a great university

establishment as there is in a street or a city bearing a great man's name, like Washington Place or Baltimore.

This is an era of educational endowment upon a generous scale. The most recent published report of Col. Dawson, the commissioner of education, shows that the sum total of noteworthy educational gifts during the year 1886-87 was nearly five million dollars. More than two-thirds of the entire amount was distributed among nine institutions, four of them collegiate, one academic, three professional, and one technical. The institution most highly favored was Harvard University, which received from individual sources nearly a million dollars. From one man came a legacy of \$630,000. Our nearer neighbor, Haverford College, supported by the Society of Friends, received \$700,000 in one bequest. Of the 209 gifts recorded by the commissioner of education, 25 represent \$50,000 or more, 72 were sums between \$5,000 and \$49,000, and 112 were sums less than \$5,000. The most striking fact in all this record of philanthropy is that such a large proportion of the entire amount, fully two-thirds, was given to higher education. The year 1888 is richer than 1887 in individual bounty to institutions of learning. Nearly ten millions were given by three persons for the encouragement of manual training, etc., but there are rumors of even larger benefactions for university endowment. The collective returns for 1888 are not yet published, but it is certain that the past year will surpass any hitherto recorded in the annals of American education.

Whatever forms modern philanthropy may take, one thing is certain, universities are not likely to be forgotten. While the Johns Hopkins University undoubtedly has most to expect from private philanthropy, like that which has already built up the city, it is not beyond the bounds of possibility to hope that the State of Maryland may some day extend to our institution what George Washington modestly called a "favoring hand." At present this State, by the exercise of its taxing power, takes from the Johns Hopkins the sum of nearly \$1,100,000, and from the Johns Hopkins Hospital the sum of \$33,000, a year. From our original patrimony Baltimore County took a collateral inheritance tax of \$36,000.

The exemption of college property, even the property of professors, from taxation was well-nigh the universal custom in the English colonies of North America. To this day, Maryland exempts from taxation all buildings, furniture, equipments, and libraries of incorporated educational or literary institutions, with the land appertaining to them; in other words, all unproductive property actually in use for educational purposes. This principle of exempting the property of institutions of learning is so thoroughly embedded in the constitutional, statutory, and customary law of almost every State in the American Union, that such exemption may be recognized, like the principles of Roman law, as sovereign common sense. But some American States go much further, and exempt the productive property of colleges and universities, their savings and investments, the income of which is applied to educational objects. The personal property and real estate belonging to educational institutions are exempt from taxation in each of the following States: Maine, Vermont, Rhode Island, Virginia, Kentucky, Kansas, and Nebraska, and probably in others whose statutory laws permit exemption but whose customs and policy vary.

Exemption from taxation is a manifest duty which the State of Maryland owes to an institution which is now using all the income from its productive capital, as well as its buildings, books, and apparatus, for the higher education of Maryland youth. Indeed, one might go further, and say that the Johns Hopkins is doing for Maryland what most States endeavor to secure by large annual appropriations. This institution is to-day discharging the functions of a State university, and is paying for the privilege of providing what is usually regarded as the duty of the State to provide.

The encouragement of higher education by government aid, in one form or another, has been a recognized principle of public policy in every enlightened State, whether ancient or modern. Older than the recognition of popular education as a public duty was the endowment of colleges and universities at public expense for the education of men who were to serve Church or State. It is a mistake to think that the foundation of institutions by princes or prelates was a purely private matter. The money or the land

always came from the people in one form or another, and the benefit of endowment returned to the people sooner or later. Popular education is the historic outgrowth of the higher education in every civilized country, and those countries which have done most for universities have the best schools for the people. It is an error to suppose that endowment of the higher learning is confined to Roman and German emperors, French and English kings. Crowned and uncrowned republics have pursued the same public policy. Indeed, the liberality of government towards art and science always increases with the progress of liberal ideas, even in monarchical countries like Germany, where, since the introduction of parliamentary government, appropriations for university education have greatly increased. The total cost of maintaining the Prussian universities, as shown by the reports of our commissioner of education, is about two million dollars a year. Only about nine per cent of this enormous outlay is met by tuition-fees. The State contributes all the rest in endowments and appropriations. Prussia now gives to her universities more than twice as much as she did before the Franco-Prussian war, as shown by the report of our commissioner at the Paris Exposition in 1867. In that year France gave her faculties of higher instruction only \$765,764. After the overthrow of the second empire, popular appropriations for higher education greatly increased. The budget for 1888 shows that France now appropriates for college and university faculties \$2,330,000 a year, more than three times the amount granted under Louis Napoleon. The little republic of Switzerland, with a population of only three millions, supports four state universities, having altogether more than three hundred instructors. Its cantons, corresponding upon a small scale to our States, expend over \$300,000 a year upon the higher education. The Federal Government of Switzerland appropriated, in 1887, \$115,000 to the polytechnicum, and \$36,000 in subsidies to cantonal schools, industrial and agricultural, besides bestowing regularly \$10,000 a year for the encouragement of Swiss art. The aggregate revenues of the colleges of Oxford, based upon innumerable historic endowments, public and private, now amount to fully two million dollars a year. The income of the Cambridge College endowments amounts to quite as much. But all this, it may be said, represents the policy of foreign lands. Let us look at home, and see what is done in our own American commonwealths.

Maryland began her educational history by paying a tobacco-tax for the support of William and Mary College. This colonial generosity to another State has a historic parallel in the appropriation of a township of land by Vermont for the encouragement of Dartmouth College in the State of New Hampshire, and in the corn that was sent from New Haven to the support of young Harvard. In colonial days Maryland had her county schools, some of them classical, like King William's School at Annapolis. All were founded by authority of the Colonial Government, and supported by aid from the public treasury. The principle of State aid to higher education runs throughout the entire history of both State and Colony.

The present generation has not been so generous to the cause of higher education as were the fathers of the State; but nevertheless Maryland, in her entire history, has appropriated something over \$650,000 for what may be strictly called college education, not counting \$60,000 given to the State Agricultural College, nor \$40,000 proceeding from State lotteries. While this collective bounty is small, it is money given by voluntary taxation, and not taken from institutions of learning. Most of the amount was raised in times when the State was poor or heavily in debt, and when public money came with difficulty. Moreover, this financial generosity of Maryland establishes the principle for which we are contending; namely, that this State, like all other enlightened States in the world, has recognized the duty of support to higher and unsectarian institutions of learning. She has at different times appropriated \$650,000 to colleges and the University of Maryland from her public treasury.

Let us now inquire what other States in the American Union have done for higher education, always recognizing of course great inequality in State population and in the taxable basis.

Virginia, whose earliest educational foundations Maryland helped to lay by her tobacco-tax, has expended upon colleges and univer-

sity over two million dollars during her history as a State, not counting the colonial bounty to William and Mary. Since the war, Virginia has given her university \$40,000 a year. Before the war, she gave \$15,000 a year. The original university establishment cost the State about \$400,000. The State of South Carolina was Jefferson's model for generous appropriations to the cause of sound learning. She has given two million and eight hundred thousand dollars to that object. Georgia has given \$938,000 for the same purpose. Louisiana has given \$794,000 from her State treasury for the higher education in recent years, and, according to the testimony of her own authorities, has distributed over two millions among schools, academies, and colleges. Texas has spent upon college education \$382,000, and has given for higher education two and one-quarter million acres of land. The educational foundations, both academic and popular, in the Lone Star State, are among the richest in America.

Turning now to the Great West, we find that Michigan has given over two million dollars to higher education. She supports a university which is as conspicuous in the North-west as the University of Virginia is in the South, upon one-twentieth of a mill tax on every dollar of taxable property in the State. That means half a cent on every hundred dollars. This university tax-rate yielded last year \$47,272. Wisconsin pays one-eighth of a mill tax for her university, and that yields \$74,000 per annum. Wisconsin has given for higher education \$1,200,000. Nebraska is even more generous to her State university: she grants three-eighths of a mill tax, yielding about \$60,000 a year. The State of California grants one-tenth of a mill tax, which yielded last year over \$76,000. Besides this, the University of California has a permanent State endowment of \$811,000, yielding an annual income of \$52,000, making a total of \$128,000 which the State gives annually to its highest institution of learning. Altogether California has expended upon higher education two and one-half million dollars.

It is needless to give further illustrations of State aid to American universities. These statistics have been carefully collected from original documents by one of our historical students, who are making important contributions to American educational history, to be published by the United States Bureau of Education. The principle of State aid to at least one leading university in each commonwealth is established in every one of the Southern and Western States. In New England, Harvard and Yale and other higher institutions of learning appear now to flourish upon individual endowments and private philanthropy; but almost every one of these collegiate institutions, at one time or another, has received State aid. Harvard was really a State institution. She inherited only £800 and 320 books from John Harvard. The towns were taxed in her interest, and every family paid its peck of corn to make, as it were, hockeak for President Dunster and his faculty. Harvard College has had more than half a million dollars from the treasury of Massachusetts. Yale has had about \$200,000 from the State of Connecticut. While undoubtedly the most generous gifts have come to New England colleges from private sources, yet every one of them, in time of emergency, has come boldly before representatives of the people, and stated the want. They have always obtained State aid when it was needed. Last year the Massachusetts Institute of Technology became somewhat embarrassed financially, and asked the Legislature for \$100,000. The institution got \$200,000, twice what it asked for, upon conditions that were easy to meet.

Can the State of Maryland and the friends of the Johns Hopkins ignore the abundant testimony in favor of the encouragement of university education, not only by exemption from burdensome taxation, but by positive appropriations? If occasion arises, it will be proper and legitimate for the friends of this institution to go before the people of Maryland and say what is needed. Private philanthropy will do all it can, but public interest demands that the State should do its part by throwing off needless taxes, and settling for what it has already taken away.

Do you say that all this would lead to meddling interference by the politicians? That is what everybody said when a university was founded by the Prussian Government in Berlin. That is the stock argument against all State universities. But there stand today Berlin and all the German universities firm and untroubled

upon state foundations. The whole South and the entire West are full of educational establishments by the State. Some of them, like the Universities of Virginia, Michigan, and Wisconsin, are beacon lights of intelligent and non-partisan administration. Have Washington politicians done any harm to the Smithsonian Institution? On the contrary, they have indirectly increased its economic power by appropriations amounting to nearly two million dollars. They allow the secretary of the Smithsonian to direct the expenditure of \$220,000 a year. Congress allows the Smithsonian to be managed by a board of regents composed of distinguished college presidents and public men of spotless integrity. Amid all the changes in the civil service, no man has ever been displaced for political reasons from either the Smithsonian Institution or the National Museum. These facts are stated upon good authority.

What are the serious thoughts that have been emphasized in this address?

1. The Johns Hopkins is now a truly national university upon local and individual foundations.
2. This noble institution which benefits Baltimore, Maryland, and the whole country, especially the South and West, can be strengthened most efficiently by further local and individual endowments.
3. The examples of history at home as well as abroad show that States encourage universities by wise exemption from burdensome taxation and by generous appropriations, if original endowments and private philanthropy prove inadequate.
4. The development of public opinion, based upon a knowledge of present facts and upon existing relations of this university to Baltimore and Maryland, is the best way to encourage higher education in this city, in this State, and in this country.

BOOK-REVIEWS.

The Government of the People of the United States. By FRANCIS NEWTON THORPE. Philadelphia, Eldredge & Brother. 12^o. 90 cents.

WORKS on the American system of government multiply apace; and, if their quality was always good, our young people would have superabundant means of information about their public duties. Candor compels us to say, however, that the treatise now before us is defective in some very important respects. Its chief fault is that it attempts too much. It undertakes to describe not only the Federal Government, but also those of the States, towns, and counties, and in addition to relate the history of constitutional government from the landing of the Anglo-Saxons in England to the present time, all in the space of little more than two hundred pages. The necessary consequence is, that, in spite of condensation and brevity of expression, no part of the work is thoroughly done. The least satisfactory part, as might be expected, is that relating to local affairs; the town and county governments differing so widely in different States, that no single description will apply to them all. For instance: Mr. Thorpe says that the school directors of the town levy the school taxes, that the selectmen make the local laws and ordinances, that the county has the care and support of the poor, and that there is a county superintendent of schools; but, though these statements may be true of his own State of Pennsylvania, they are wholly untrue of Massachusetts. As for the history of constitutional government, which occupies the introductory part of this book, that obviously requires a separate work; and the chapters here given to it are altogether inadequate. We may add that the book contains a facsimile of the Declaration of Independence, several fancy pictures of historical events, and a gaudy spread eagle for frontispiece, none of which are likely to contribute much to political education.

A Text-Book of Elementary Biology. By R. J. HARVEY GIBSON. London and New York, Longmans, Green, & Co. 16^o. \$1.75.

MR. GIBSON'S experience as a teacher of biology has satisfied him, that, in order to instruct the student in this most important department, the beaten track must be left, and a new departure taken. To properly appreciate it, and to benefit by its study, a student must first undergo a preliminary training in the facts and

conclusions of physics and chemistry, and, in addition, must devote not a little time and labor to studying the application of the more general laws of these sciences to the special phenomena of plant and animal life. In this text-book the author has summarized briefly the principal conclusions of the inorganic sciences, devoting special attention to those laws on which the higher science of biology is founded, and has endeavored to keep prominently in the foreground the dependence of biology on physics and chemistry, and the relationship of morphological and physiological details to general principles.

Matter, energy, the classification of chemical compounds, and the laws of chemical change, are discussed in the first chapter; and the author then proceeds to consider protoplasm in its many and varied aspects. Individual and tribal life, with distribution and classification, are thoroughly treated.

The *Proteita*, *Protophyta*, *Protozoa*, *Metaphyta*, and *Metazoa* are described in most minute detail. The illustrations are excellent, and are to a great extent original. The typography and general execution of the book leave nothing to be desired. As a text-book of elementary biology, it is one of the best that have ever been published.

Chemical Lecture Notes. By PETER T. AUSTEN. New York, Wiley. 12°. \$1.

THIS book is not intended as a text-book, but is simply a collection of notes and observations on certain topics, which, experience as a teacher of chemistry in Rutgers College and the New Jersey State Scientific School has shown Professor Austen, give the student more or less trouble. While no attempt has been made to include all the rocks and shoals on which chemical students suffer shipwreck, still the author has succeeded in making lucid many of the topics which are not rendered sufficiently intelligible by the average text-book. Valence, atomicity, the laws of Boyle, Charles, and Mariotte, can no longer be a mystery to a student of these lecture-notes. We recommend them to those who have found difficulty in comprehending the intricacies of modern chemistry, and equally to those who would escape the hard places in this science, so numerous even when studied with the best of helps and teachers.

AMONG THE PUBLISHERS.

WE have received from A. Lovell & Co. "Greene's Language Half-Blanks, No. 1," by H. R. Greene, a pamphlet designed to teach the elements of English grammar by means of exercises and diagrams. Examples are given of the parts of speech, and the construction of the sentence is duly explained, and the pupil is then to write short sentences, the principal words being furnished him to illustrate what has been told him. These sentences are to be arranged in tables, and the different elements of the sentence indicated by certain marks written under the words. What the precise value of Mr. Greene's system may be, experience must decide; but marks and diagrams have no connection with language as such, and can at best be nothing more than very slight helps. The book is one of a series ending with a full grammar.

— Messrs. Ginn & Co. of Boston have issued "An Introduction to the Poetry of Robert Browning," by Professor William J. Alexander of Halifax, N.S. The author remarks on the difficulty experienced in understanding any new writer, and on the special difficulty of understanding Browning because of his obscurity; and he has prepared this work with the object of clearing up some of these difficulties, and making his author more comprehensible to the mass of readers. He finds the chief motive of Browning's work in his belief in the central doctrines of Christianity, which he has endeavored to illustrate and enforce. One chapter is given to Browning's philosophy, and another to his theory of art; and the remainder of the book is devoted to an account of his mental development as exhibited in his various works.

— D. Appleton & Co. will publish immediately a treatise by the Hon. Seymour Dexter of Elmira, N.Y., on "Co-operative Savings and Loan Associations," which will include an examination of building and loan associations, mutual savings and loan associations, accumulating fund associations, co-operative banks, etc.

The appendix will contain laws of New York, Pennsylvania, and Massachusetts, forms for Articles of associations, by-laws, account-books, and other useful information on the subject. The author, who is judge probate of Chemung County, has been president of the Chemung Valley Mutual Association for fourteen years, and is high authority on the subject of which he treats. They also announce "A Manual of Instruction in the Principles of Prompt Aid to the Injured," designed for military and civil use, by Dr. Alvah H. Doty; and a new book by Mr. O. B. Bunce, entitled "The Story of Happinoland and other Legends," which is to be issued in the Gainsborough Series. The latter consists of four slight sketches,—"The Story of Happinoland" (which, being translated, is "Happy-no-land"), "A Millionaire's Millions," "The City Beautiful," and "John's Attic;" all of which, the latter, however, only slightly, involve questions in social science.

— Harper & Brothers have ready this week a concise instructive work on "Constitutional Government in Spain," by J. L. M. Curry, LL.D., predecessor of Mr. Perry Belmont as minister of the United States in Spain. It is the result of some years of close study of the subject, and of actual observation of Spanish political and social life during the author's official residence in the country. Valuable appendices are added, summarizing the careers of aspirants to the Spanish throne,—Fernando, Leopold, Duke of Montpensier, and Amadeo; giving sketches of Christina, Isabel, Alfonso XII., the Infantas, the Queen Regent, and Alfonso XIII.; describing the present condition of Spain in its political, social, and industrial aspects; and, lastly, explaining briefly the acquisition of Florida by the United States. They have also just ready "Choice Cookery," by Catherine Owen, author of "Ten Dollars Enough," etc., the object of which is to help those who wish to know at a glance what is newest and best in modern cookery.

— David McKay, Philadelphia, will shortly publish a new edition of Joel Cook's "Holiday Tour in Europe," formerly published by Porter & Coates.

— The *American Magazine* suspended publication last December.

— *The Index*, published by E. R. Walker, Chicago, is a little four-page monthly paper that will attempt to take "a glance at the leading features of the forthcoming periodicals."

— *Once a Week* has been enlarged, and includes a greater variety of contents. The most noticeable thing in the current number is the first instalment of a Stockton story, called after its heroine, "Ardis Claverden."

— *The Advance Sheet*, published by C. A. Watson, New York, will attempt to give a monthly survey of periodical literature, indexing the contents of the leading periodicals for the next month, with such comments as will make the announcements as attractive as possible.

— The two new volumes of "Letters of Carlyle" which Professor C. E. Norton has edited are mostly addressed to the various members of Carlyle's family, and afford a tolerably continuous account of his life from his marriage to the period when his fame was about to be established by the publication of his "French Revolution." Messrs. Macmillan are to publish them speedily.

— The new edition of Queen & Co.'s "Chemical Apparatus Catalogue" is now published. It contains 368 pages, with about 1,200 illustrations, and will be mailed to any address on receipt of fifty cents, which sum will be deducted from the first purchase made from it amounting to ten dollars or more. This is a very elaborate work, containing the most useful apparatus, and the firm feels confident that it will be considered by chemists a standard for reference. While the quality of the apparatus is maintained, most of the prices have been reduced.

— In the *Contemporary Review* for March (New York, Leonard Scott Publication Company), interest centres in the paper on the "Panama Canal," by Edward Whymper, with its intelligent diagrams and maps; Archibald Forbes criticises some of Lord Wolseley's recent utterances; Dr. Dale continues his interesting papers on Australia; Canon Wilberforce treats of Ireland's demands; and Mr. Clerke describes the observatory at the Cape of Good Hope.

HARPER'S READERS.

	Pages.	Introduction Price.	List Price.
HARPER'S First Reader	144	20cts.	24cts.
HARPER'S Second Reader	208	30 "	36 "
HARPER'S Third Reader	316	40 "	48 "
HARPER'S Fourth Reader	420	50 "	60 "
HARPER'S Fifth Reader			

[In Preparation.]

Although published less than six months ago Harper's Readers have already been adopted and are now in satisfactory use in

MORE THAN FIVE HUNDRED CITIES AND TOWNS

including NEW YORK CITY, PHILADELPHIA, JERSEY CITY, N.J., FALL RIVER, MASS., ITHACA, N.Y., JACKSON, MICH., ELGIN, ILL., PATERSON, N.J., and many other places of importance. They have been adopted by the Board of Education of

THE STATE OF SOUTH CAROLINA

for use in the schools of that state, and have received the official sanction of officers and school boards in

HUNDREDS OF COUNTIES AND COUNTRY DISTRICTS.

in all parts of the Union. They have also been adopted for supplementary use in the schools of CHICAGO, ILL., MINNEAPOLIS, MINN., DULUTH, MINN., PEORIA, ILL., and many others of the best schools in all parts of the country. They have not only been introduced into the schools of the places above referred to, but they have everywhere been received with favor and have been accorded, by teachers and others, the most enthusiastic commendation.

School committees and others whose duty it is to select text-books for schools should see these Readers before adopting others. Copies for examination will be sent on receipt of the introduction price.

HARPER & BROTHERS, Publishers,
FRANKLIN SQUARE, - - - - NEW YORK.



"**ENCYCLOPÆDIA BRITANNICA.**" Popular Reprint, \$2.50 per volume, 24 volumes, making the set complete, now ready for delivery. One-half the price of the Scribner & Stoddart editions, and less than one-third the price of the original English editions which we have reproduced in fac-simile texts, maps, plates and illustrations, same number of pages and same number of volumes.

Call and examine sets and compare with the other editions, all of which are in our office. Circulars and sample pages mailed.

"THE LITERARY MARVEL OF THE AGE."

THE HENRY G. ALLEN COMPANY, PUBLISHERS,
739 and 741 Broadway, New York.

Unfinished Worlds:

A STORY IN ASTRONOMY. By S. H. PARKES, F.R.A.S., F.L.S. With 9 Illustrative Diagrams. Price \$1.50, cloth.

"We have read this with profound interest. Mr. Parkes writes with a dignity and love of truth befitting so exalted a theme, with that glow of enthusiasm which a genuine student of the wonders of the heavens may be expected to feel."—*Nonconformist*.

"Mr. Parkes gives a deeply interesting account of the long series of experiments by Rev. Dr. Ballinger, which have a direct bearing on the late Mr. Darwin's theory of evolution, especially as it relates to the supposed transmutation of every elementary form of life into new and more advanced species."—*N. Y. Daily Herald*.

"No clearer or more readable book could be recommended. Excellent illustrative diagrams."—*Glasgow Herald*.

JAMES POIT & CO., PUBLISHERS,
Astor Place, New York.

Schools.

NEW JERSEY, PLAINFIELD.

THE CHESTNUTS.—Parents with daughters to educate, or orphan girls with companion, may find a comfortable home, with school instruction by applying to Miss E. E. Kenyon.

CONNECTICUT, NEW HAVEN.

MRS. CADY'S SCHOOL FOR YOUNG LADIES. Prepares for Smith and Wellesley, and admits to Vassar by Certificate. Circulars. Early application necessary.

VERMONT, BURLINGTON.

VERMONT EPISCOPAL INSTITUTE. Boarding School for Boys. Prepares for College or Business. Military drill. Terms moderate. Fifty-seventh half-year opens September 3, 1888. Send for catalogue.

H. H. ROSS, A.M., Principal.

Publications received at Editor's Office, Feb. 25-March 2.

AMERICAN Institute of Electrical Engineers, Transactions of the. Vol. V. New York, The Institute. 435 p. 8°.

GANGUILLET, E. and KUTTER, W. R. A General Formula for the Uniform Flow of Water in Rivers and other Channels. Tr. by R. Hering and J. C. Trautwine, Jr. New York, Wiley; London, E. & F. N. Spon. 240 p. 8°. \$4.

LAMARTINE, A. de. Jeanne d'Arc. Ed. by Albert Barrère. Boston, Heath. 188 p. 16°.

LAURIE, S. S. Occasional Addresses on Educational Subjects. Cambridge, Eng., University Pr. 215 p. 12°. (New York, Macmillan, \$1.25.)

MERRINAM, M. A Treatise on Hydraulics. New York, Wiley. 381 p. 8°. \$3.50.

THOMSON, W. Popular Lectures and Addresses. (Nature Series.) Vol. I. Constitution of Matter. London and New York, Macmillan. 460 p. 12°. \$2.

— The favorable reception accorded in the past to the Easter-card packets put up by H. H. Carter & Co., Boston, has encouraged this enterprising house to prepare their 1889 packages with even greater care than heretofore. Being one of the largest dealers in this class of goods in the country, and selling paper directly from the mills, they are enabled to give exceptionally good values. People dealing with them are sure to find their goods satisfactory.

— Contortionists and "Snake-men" will be described in the April *Contortier* by Dr. Thomas Dwight of the Harvard Medical School, who has made a thorough investigation of their peculiar anatomy. Photographs of several expert contortionists in their most wonderful feats will be reproduced in the article. Henrik Ibsen, the Norwegian dramatist, a literary genius little known in this country, is the subject of a paper in the same number. Charles Francis Adams's paper on "The Prevention of Railway Strikes" was written nearly three years ago, but held back by the author for fear that, in existing conditions, it might result in more harm than good. A practical scheme for giving employees a part in the management of the road is suggested. Pictures showing stages in the building of the great ocean steamers, the "City of New York" and others, will illustrate Mr. Rideing's article on "Ocean Greyhounds."

— At a regular meeting of the Nineteenth Century Club, New York, on the 9th of November last, a resolution was passed appointing a committee to prepare and publish a memorial volume to the founder and first president of the club, and to solicit subscriptions to defray the expenses. This volume is now ready for publication. The book will contain the funeral orations, the addresses delivered at the memorial meetings, and essays and letters since received. It will consist of about two hundred pages, octavo, printed on heavy Holland paper, and richly bound in levant morocco. This edition, upon which no pains or expense will be spared to make it worthy of the club and of the occasion, will cost five dollars per copy. For those who desire it, an edition, handsomely bound in cloth, will be supplied at a cost of three dollars per copy. As frontispiece there will be a portrait of Courtlandt Palmer. As the committee have decided to print only such copies of the memorial volume as are ordered in advance, it is desirable that no time should be lost in notifying John H. Beach, 25 East 57th Street, of the number of copies and the kind of binding which may be desired.

— Mr. Andrew Lang is a frequent contributor of leading articles on social and literary topics to the *London Daily News*; and some of his admirers think that not a little of his most characteristic writing is to be found in these "leaders," as the English call them. One of these admirers, with the author's permission, has gathered some thirty of these essaylets in a volume which Longmans, Green, & Co. will publish shortly, under the apt title of "Lost Leaders." Among the subjects treated are "Thackeray's Drawings," the "Art of Dining," "Phiz," "Amateur Authors," and the "Lending of Books."

— James W. Queen & Co., 924 Chestnut Street, Philadelphia, announce a clearance sale of microscopes, objectives, accessories, and sundries, and have issued a new catalogue. The firm's stock-taking strongly calls attention to the fact that some microscopical accessories (and other goods) have not shown, of late, such activity of commercial movement as is desirable. They have therefore picked them out, described them in their special catalogue, and cut the prices, to make them move along. The articles described in this list are new and perfect unless otherwise noted.

— The following are from the table of contents of the April number of *The Chautauquan*: "Gossip about Greece," by J. P. Mahaffy, M.A., of Dublin University; "Agesilaus," by Thomas D. Seymour, M.A., of Yale University; "Greek Art," by Clarence Cook; "Color in the Animal World," by the Rev. J. G. Wood; "What Inventors have done for Farming," by James K. Reeve; "The Care of the Insane," by A. G. Warner, Ph.D.; "Sunday Labor," by the Rev. Jesse H. Jones; "The First Presidential Inauguration," by Charles Carleton Coffin; "English Pronunciation," by Robert McLean Cumnock, of Northwestern University; "Stu-

dent Life in Paris," by F. M. Warren; "British Columbia," by Sheldon Jackson, D.D., United States general agent of education in Alaska; "Women's Clubs in London," by Susan Hayes Ward; "A Virginia Plantation," by C. W. Coleman; "The Secret Service of the Treasury Department," by Mrs. Carl Barus.

LETTERS TO THE EDITOR.

*Correspondents are requested to be as brief as possible. The writer's name is in all cases required as proof of good faith. The editor will be glad to publish any queries consonant with the character of the journal. Twenty copies of the number containing his communication will be furnished free to any correspondent on request.

Origin of Fish in Isolated Waters.

A FEW months ago I called attention to the abundance of fish in certain isolated ponds in Florida, which become dry at times. (*Science*, xii, p. 280). Mr. Henry W. Howe of Boston suggested in reply that fish may be transported from one pond to another by birds. This is an interesting suggestion, as indicating a possible explanation, though I am not aware that there is any evidence to that effect at present. Alligators might also be mentioned as a possible transporting agency. But any such means would seem to be inadequate to produce the observed results. Since my former communication, I have had further opportunity to investigate this subject. The past season in Florida has been a very unusual one. The rainy season, which usually begins in the peninsular portion of the State, about the 1st of June, failed to make its appearance, and a severe drought resulted. Ponds, swamps, creeks, and wells became dry. Then in the fall, when the rainy season usually closes, "the windows of heaven were opened," and a very wet fall and winter followed. But the ponds, which were dry for many weeks during the hottest part of the year, now swarm with little fish; and during the heavy rains fish could be seen not only in ponds, but in ditches beside the railroad, in ditches beside the fields, and in shallow rain pools which would dry in a few days, and had no connection with other waters. In fact, minnows have been almost abundant enough to give color to the old notion of the *raining-down* of fish, frogs, tom-cats; lean meat, etc., reports of which are occasionally seen in the newspapers. There is certainly some certain and rapid means of populating the waters of isolated and temporary pools, which is well worth investigating.

CHS. B. PALMER,

Orange Heights, Fla., March 11.

The Soaring of Birds.

I HOPE I may be allowed space for a few short comments on Messrs. Gilbert and Kimball's letters in *Science*, xiii, pp. 169 and 170.

My conception of relative velocity does not differ from Mr. Gilbert's, as he supposes, and accordingly the statements of his paper were as clear to me as the restatements of his letter. So far as his presentation of the differential motion theory of soaring is concerned, my only criticism was that his assumption as to the dynamical effect of the wind on the bird during the turn seemed to demand more than mere assertion. One of my statements as to what this assumption implied, Mr. Gilbert questions as follows: "I do not admit that during the turn his [the bird's] velocity relative to the earth will change by an amount equal to twice the velocity, relative to the earth, of the medium in which the turn is made." His velocity relative to the earth will change by an amount equal to twice his velocity relative to the medium." Both positions are correct, however. We are merely using the term "velocity" in different senses.—Mr. Gilbert as connoting both rate and direction of motion, I as connoting rate of motion simply. I used the term in this sense, because it was the sense in which Mr. Gilbert had used it when he asserted that the velocity of the bird relative to the air would be the same after a turn as before.

Both Mr. Gilbert and Dr. Kimball hold that the velocity of wind or bird relative to the earth "has nothing to do with the question." That surely depends, however, upon what the question is. If we undertake, as I did, to account for the fact that some birds are able, without flapping of wings, to describe paths which, *relatively to the earth*, are spirals about lines inclined upwards, velocities relative to the earth must be taken into consideration. If, how-

ever, the question is the somewhat simpler one of determining the conditions under which a bird can gain elevation without expending energy, velocities relative to the earth may, of course, be ignored.

There is, as I now see, a great advantage in making the simpler investigation first: for, as Dr. Kimball has clearly shown, as soon as we recognize the fact that the bird's motion relative to the medium depends only on their relative velocity, it becomes clear that gain of elevation, and consequently the whole phenomenon of soaring, is impossible in a uniform horizontal wind.

It follows that there was an error in my theory of soaring. Mr. Gilbert thinks it due in part to my assuming it to be possible for a bird to glide in a wind moving faster than itself, with its head to leeward; but I see no reason why birds should not accomplish this fact, and am satisfied that I have often seen them do it. He also holds that my bird, "in passing from a negative velocity relative to the air, to a positive velocity relative to the air, must pass through the phase of no velocity relative to the air, in which he is practically helpless." But I was dealing with the bird's component velocity in the line of the wind's motion; and he might always have a velocity relative to the air, though its component in that line might be zero. The error which I made was in assuming, that, under the conditions of flight to which I subjected my bird, the turn to leeward was possible. From the way in which I made him fly, it is clear that the resultant force exerted on him, at every point of his supposed path, must be upward and to leeward. That being the case, the turn to leeward could not be accomplished, and consequently the path he was supposed to describe was an impossible path.

I feel that I must apologize to those of your readers who may have followed me in what may fitly be called "a wild-goose chase."

J. G. MACGREGOR.

Dalhousie College, Halifax, N.S., March 8.

"Shall We Teach Geology?"

IN Professor Winchell's remarks on my review of his recent work, there are only two points that call for reply. First, as to the study of history, which, according to him, trains no faculty but verbal memory. He now says that his "criticisms on history contemplate it as a study urged upon children in the early stages of education," and that in the colleges it is pursued in a better way. But, even if imperfectly taught, history trains far more important faculties than verbal memory. It exercises the intellect generally quite as much as geology does, and it also calls into play the moral judgment and the sympathies, which geology does not. To Professor Winchell the old red sandstone may be a more important topic of study than the Roman Empire, and the plesiosaurus a more interesting object of contemplation than Washington or Columbus; but to the mass of men this is not so. As to the time that Professor Winchell would have spent on geology, I may have misapprehended his meaning; and, if so, I am glad to be corrected. I haven't his book by me at present; but, if I remember rightly, he says that the study ought to be taken up in the primary schools, and continued through the various grades, which I understood to mean that the subject should be studied more or less every year. He now says that he only wants it taken up several times at intervals, and not pursued continuously, which is more moderate. I do not see, however, how even so much study of geology is possible; because, not to speak of languages and literature, there are many sciences of greater importance than geology, which ought, therefore, to be studied first. Such are arithmetic and geometry, geography, physics, human physiology, psychology, ethics, civil polity, and history; and I do not see how even all of these can be taught in the public schools. If these views are correct, geology can be nothing but an optional study in the high schools and colleges, while in the lower schools it can have no proper place.

THE REVIEWER.

Curves of Literary Style.

IN the interesting researches on this subject by Professor Mendenhall described in your journal in 1887, words were classified according to the number of letters in them, and curves made ac-

ordingly. As he pointed out, there are many ways in which the principle of his method may be applied; and I have lately thought some instructive results might be obtained from examining sentences with regard to length, as measured by the number of words.

Length of sentences is a matter in which pronounced styles differ greatly. Doubtless this is associated with psychological peculiarities which it might be instructive to inquire into. The mental machine (so to speak) which, for example, turns out the long parenthetical sentences of Gladstone, must be very different in design from that which yields the simple and direct utterances of John Bright.

I have made an examination of 300 sentences in each of the following works: Carlyle's "French Revolution," De Quincey's "Confessions," and Johnson's "Rambler." The number of words in each sentence was counted, and the sentences grouped accordingly. Then the sentences with words up to 10 were added together, those with words from 10 to 20, from 20 to 30, and so on. The accompanying curves were then obtained from these data. Let it be clearly understood what they mean. The plain line curve (for Carlyle) means that in the 300 sentences of the passage selected there were 62 containing words varying in number up to 10, while 100 had from 10 to 20, and so on. The result is roughly as we might expect: short sentences form the bulk of the Carlyle passage, his maximum being in the class 10 to 20, and sentences of more than 50 words are comparatively few. There are none beyond 100. De Quincey and Johnson, on the other

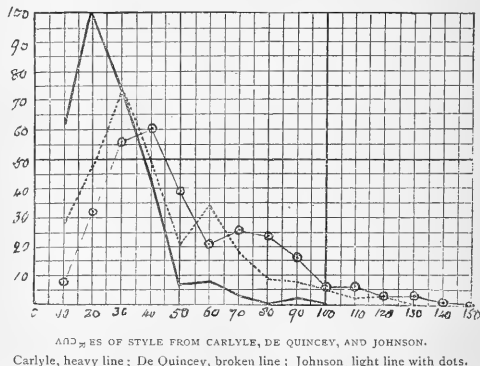

NUMBERS OF STYLE FROM CARLYLE, DE QUINCEY, AND JOHNSON.

Carlyle, heavy line; De Quincey, broken line; Johnson, light line with dots.

hand, have an abundance of longer sentences. De Quincey's most numerous class is that of 20 to 30 words; Johnson's, 30 to 40. But the curve of the former does not die down till after 110 to 120 words (really there was one inordinate sentence of 170, not shown in the diagram); while Johnson's is further protracted to 130 to 140.

I do not affirm the constancy of these curves: they only apply to the specified passages of 300 sentences. These few lines are merely by way of suggestion, and should any reader have the time and patience to pursue the inquiry further, he might, I think, find his labors not without some useful results.

It might be useful to see in what degree these curves approximate to constancy, or come short of it. One would like to know better than we do at present, how far the method, in any of its forms, is reliable or helpful in settling disputed questions of authorship, or in tracing anonymous literature to its source.

I would suggest an examination of the words used by speakers or writers as likely to be instructive.

A. B. M.

London, March 7.

Wind-Velocity and Wind-Pressure.

FROM time to time there have appeared discussions of these questions, so important to the practical engineer. It seems probable that the first of these, as far as relates to the relation between wind-movement and the travel of the cups of Robinson's anemometer, is soon to be definitely settled by indubitable experiments.

Professor Robinson first considered that the cups moved with one-third the wind-velocity, but this has been repeatedly called in question. In later times the more common method of investigation has been by whirling the anemometer on arms from 11 to 35 feet in length. It would seem as though arms of 11 feet could hardly give satisfactory results.

In discussions of this relation, the utmost confusion has arisen by wrongly considering the so-called "anemometer factor," and by making the same an entirely different quantity, and one from which it was supposed a "friction constant" had been separated. The statement that anemometers used in this country give 20 per cent too great wind-movement has been based on this misconception. Let x = "anemometer factor," w = wind-movement, and v = travel of the cups: we have,

$$x = \frac{w}{v} \quad (1)$$

Let a = "friction constant," and b = another constant: we have,

$$w = a + bv \quad (2)$$

Substituting the value of v in (1), we have,

$$x = \frac{bw}{w-a} \quad (3)$$

In experiments at St. Petersburg it was found that an anemometer with 6.72-inch arms and 4-inch cups, the same as used in this country, had $b = 2.47$, and $a =$ about 2 miles per hour. Assuming w at various velocities (5, 10, 15, 20, and 25), we obtain from (3), for x , 4.12, 3.09, 2.85, 2.74, and 2.68 respectively.

We see that even these earlier investigations show our anemometer (with factor 3) almost exactly correct for velocities from 10 to 15 miles per hour, while at less velocities it gives too little wind, and only about 12 per cent too much at 25 miles.

The wind records of this country had been so often called in question, the chief signal-officer finally made provision for an investigation of the question. The results in full will shortly be published. For our present purpose it will suffice to give the approximate results with our own anemometer, described above: with w at 5, 10, 15, 20, and 25, we obtain for x , 3.30, 3.11, 3.05, 2.98, and 2.89 respectively. These are very satisfactory, and show, that, except for high or low winds, the records are entirely correct.

It is rather singular that investigations have recently been made in England with a whirling arm of 29 feet, almost the same as that used in this country (28 feet). Unfortunately these experiments were made in the open air, and with a natural wind often 4 miles per hour. These currents vitiated all the results for velocities less than 30 miles per hour: in some cases the error amounted to 35 per cent. The helicoidal anemometer which was tested had a vane attached to keep it in the wind. It is of the same nature as the "air-meter," long since discarded for wind measurement, and only used for straight-line currents in mines or elsewhere. Fortunately in these experiments there was one day when it was nearly calm, and the results for that day do not differ from others made in a closed court. For velocities less than 25 miles per hour, these results are entirely unreliable and misleading, in the present state of our knowledge of the problem. An extended discussion of this question will be found in the *American Meteorological Journal* for March.

While much time has been expended on the above problem, yet much more has been spent in determining the relation between the velocity and pressure of the wind. This problem is by far the more difficult to solve, and to practical engineers the more important of the two. One thing is very gratifying, and that is that the investigations and practice so far have been almost entirely on the safe side; and the wonder is that buildings have not blown down at all, at least if engineers have ever allowed the commonly accepted figures to enter their computations. It is probable that in most cases engineers have assured themselves of a factor of safety far beyond any thing that any experiments have indicated. How is it that if, as some claim, the usual deductions have indicated three times too great pressure of the wind, any building has ever blown down? If we examine the matter, however, we shall find that most of the theoretical discussions, when separated from well-conducted investigations, will lead and have led far astray. One

of the most astonishing misapplications has been of Hagen's experiments, made with plates from 2 to 6 inches square at velocities from 1 to 4 miles per hour, to the side of a house 400 inches square, and with velocities of 60 or 70 miles per hour. But this is not all. Even Hagen's experiments are repudiated by those very persons who make this application, for the reason that they give an increasing pressure as the plate grows larger; so that with a house 400 inches square the pressure, according to Hagen's formula, would be seven times as great per square foot as on a plate 4 inches square. Certainly it would be very unscientific to discard the application of a formula where it does not seem satisfactory, and then apply the computation at another portion of the formula to that portion where we have discarded the same formula.

The best experiments with low velocities show no increase in pressure per square foot for plates from 4 to 24 inches square; and when plates have been exposed to the free wind, or at very high velocities, the result has shown

$$p = .005 sv^2,$$

in which p = pressure, s = surface in square feet, and v = velocity of wind in miles per hour. The recent English experiments were with a plate 6 inches square; and, even if they were not vitiated by untoward causes, it would be utterly impossible to reason from them to what the pressure would be on a surface four thousand times as great.

H. A. HAZEN.

Washington, March 18.

Queries.

44. EQUILIBRIUM. — In the account of his travels in the Colonies, the Marquis de Chastellux relates, that while at Albany, Jan. 1, 1782, he was surprised at the noise and racket with which the new year was ushered in; young folks, servants, and even negroes going from tavern to tavern, singing, and asking for drink. New Year's morning he took leave of Gen. Clinton, and adds, "I met nothing but drunken people in the streets, but what astonished me most was to see them not only walk, but run upon the ice, without falling or making a false step, whilst it was with the utmost difficulty I kept upon my legs" (*Travels in North America*, 1780-82, London, 1787, p. 441). Here is the best of evidence (for the marquis related only that which he saw; and his narrative, as well as being the most interesting "private" view of our country at that critical period, is also the most trustworthy), asserting that in some way a drunken person, or one not having to the fullest degree what we may call self-control, has a decided advantage over his supposed clearer-headed brother, who has refrained from the "flowing bowl." Is this actually the case, or is the advantage more apparent than real? Most of us have at some time noticed the truly wonderful balancings of a drunken person when in proximity to a curb or flight of stairs, and have commented thereon that a person conscious of the position could not imitate these contortions without danger to life and limb. Does extreme mental alertness, then, act as a detriment, while a blunted sensibility is an advantage to the person so conditioned? If so, the question becomes an important one, and not confined to conditions of self-imposed disability. We may need to know definitely at certain critical periods whether, in order to accomplish a given object, it is better that we should be partially blindfolded than that we should see and know all.

A. M.

Indianapolis, Ind., March 13.

Answers.

42. LOOKING TO THE LEFT. — In answer to Query 42, permit me to suggest that seats on the right as one enters a play-house are preferred, because the action on the stage is to the observer's front and left. Troopers, choruses, and principals come on the stage from the left side; and dialogue, combat, and chief business generally occur in the corner back and to the left; while the mob, as in *Cæsar*, and *Spartacus the Gladiator*, fills in the right. This is the rule in our experience, modified in some cases by the limitations imposed by the building. Again, how will "42" account for the fact that abroad, confined perhaps to England only, if you turn to the left you are right, while if you turn to the right you are wrong?

L. E. J.

GUARANTY INVESTMENT COMPANY

CAPITAL \$250,000.

Hon. ALBERT H. HORTON (Chief Justice, Kansas Supreme Court), Topeka, Kan., Pres't.

7% Guaranteed Farm Mortgages 7%

The Company calls the special attention of Investors to the following points :

- I. All loans guaranteed and interest payable semi-annually at the Importers' & Traders' National Bank, New York.
- II. Unusual fulness of information, not only about the security itself, but about the general development of the section where the farm is located.
- III. An examination each year of the general business of the Company and the Mortgages themselves by a COMMITTEE OF INVESTORS sent for the purpose.
- IV. Many hundred Mortgages taken and NOT A SINGLE FORECLOSURE.
- V. Exhibitions in New York at frequent intervals, of Kansas and Nebraska Farm Products. The Exhibition at the American Institute in the fall of 1888, received the *HIGHEST AWARD* of superiority.
- VI. Monthly Bulletins giving full information about all Mortgages offered for sale.

Address for Monthly Bulletin and Investors' Committee Report for 1888,

HENRY A. RILEY, General Eastern Manager, 191 Broadway, N.Y.

THE CHEQUE BANK LIMITED.

ESTABLISHED IN LONDON, 1873.

CHIEF OFFICE, 4 Waterloo Place, Pall Mall, London.

TRUSTEES:

The Right Honorable JOHN BRIGHT, M.P.
The Right Honorable EARL BEAUCAMP.
Bankers: Bank of England.

The Capital of the Bank and its Guarantee Fund of 500,000 is invested in Government Securities.

The Bank does not discount Notes or Bills, nor speculate, but loans its Deposits against Government Securities, thus making the Cheque Bank Cheques EQUAL TO CASH—as the Bank of England Notes are.

The Cheque Bank issues Cheques singly or in books from ONE POUND upwards, for the use of Travelers, and for others remitting money to Europe, available in every town in England, Scotland, Ireland, and Wales. In every town of Europe, and all other parts of the world, Cheque Bank Cheques are accepted as Cash by all the British Government Offices.

VISITORS TO THE PARIS EXHIBITION this summer can get the Cheque Bank Cheques cashed at 50 Banking Houses in Paris.

Travelers and others holding Cheque Bank Cheques can have their mail matter addressed to them, care of the Cheque Bank, London, who will take charge of the same and forward to any address.

For Hand-Book containing List of upwards of 2000 of the principal Banking Houses throughout the World who Cash the Cheque Bank Cheques, and for all information, apply to the AGENCY.

CHEQUE BANK, Limited,

UNITED BANK BUILDING,

2 Wall St., New York.

E. J. Mathews & Co., Agents.

REFERENCES BY PERMISSION:

JNO. W. MACKAY, Esq., President Commercial Cable Company, Mackay-Bennett Cables, New York.

F. O. FRENCH, Esq., President Manhattan Trust Co., New York, and others.

THE American Bell Telephone COMPANY. 95 MILK ST., BOSTON, MASS.

This Company owns the Letters Patent granted to Alexander Graham Bell, March 7th, 1876, No. 174,465, and January 30, 1877, No. 186,787.

The Transmission of Speech by all known forms of ELECTRIC SPEAKING TELEPHONES infringes the right secured to this Company by the above patents, and renders each individual user of telephones, not furnished by it or its licensees, responsible for such unlawful use, and all the consequences thereof and liable to suit therefor.



Brokers and Auctioneers.

R. ELLIS & CO.

BUSINESS, HOTEL AND PATENT BROKERS,
AUCTIONEERS, ETC.

No. 176 BROADWAY,

Room 46.

New York.

CLIENTS Advised free of charge.

J. P. TRAVER & CO., General Auctioneers, Real Estate and Business Brokers,

OFFICE, 23 PARK ROW,

OPPOSITE POST OFFICE, (ROOMS 14 & 15.) New York.

Mortgages Foreclosed. Cash Advanced on Consignments.
Property of Every Description Bought, Sold and Exchanged.

Wants.

A YOUNG MAN can have lucrative engagement, not only a fixed salary, but according to his work accomplished in travelling for SCIENCE. A personal interview invited.

N. D. C. HODGES,

47 Lafayette Place, New York.

C. & C. ELECTRIC MOTOR COMPANY.

Electric Motors
FOR
Arc and Incandescent Circuits, Most Economical Motor on the Market.
Regulation Perfect.
Motors Designed for all Power Purposes.

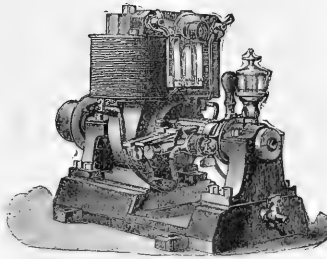

OFFICE and MANUFACTORY:
402 and 404 Greenwich Street, New York City.
New England Office, 19 Pearl St., Boston.
Philadelphia Office, 301 Arch St.
Western Office, 139-141 Adams Street Chicago.
Southern Office, 25 Carondelet Street, New Orleans.

ESTABLISHED 1859.

H. A. DREW,
Commercial Printer,
5 Clinton Place, near Broadway, New York.

Wedding Orders, Souvenirs, Invitations, Orders of Dance, etc., etc., done in the latest and most elaborate styles, at reasonable prices.
All Favors promptly attended to.

16 PAGES. THREE 16 PAGES.

Hundred Thousand new subscribers for The Family Journal and Ladies' Companion wanted. It is the most interesting and instructive paper ever issued. Subscribers will receive during the coming twelve

MONTHS

novels written by American Authors, complete in each three numbers. The story of popular works of fiction will be retold by a novel reader, the most interesting and unique feature ever introduced in any publication, giving the substance of popular and standard books by famous writers in a space easily read by the busiest people. We have engaged

FOR

this work a widely known and popular writer. Comments on Current Events, Fashions, New and Original Ideas and Designs for Ladies' Fancy Work and Household Decoration, Letters from Correspondents and their Answers, the colleges and seminaries of the United States will be treated one each month in an illustrated article, showing the particular advantage of each, cost of attendance, etc. Invaluable to parents having sons or daughters whom they desire should receive the advantages of a higher education than the ordinary school affords. Articles on Painting and Drawing, giving home instruction by a well-known artist. A trial subscription of this elegant paper will be sent to any address, three months,

TEN CENTS.

Liberal pay for literary work adapted to our columns, and for new and original drawings, designs and ideas on any subject which we can use.
Premium List the most complete in the world. We offer inducements to club raisers and agents approached by no other publishing house. The celebrated Gilbert Cut Waist Linings, which we send post paid to any one sending us two yearly subscribers at ten cents each in advance worth 50 cents; six months, 25 cents; and a three months' trial subscription for only 10 cents.

TRY IT! TRY IT! TRY IT!
and you will become a permanent reader. Address:
John L. Douglass, Publisher,
322 Broadway, N. Y.



GOOD NEWS TO LADIES.
Greatest inducements ever offered. Now's your time to get up orders for our celebrated Teas and Coffees, and secure a beautiful Gold Band or Moss Rose China Tea Set, Dinner Set, Gold Band Moss Rose or Moss Rose Watch, Brass Lamp, or Webster's Dictionary. For full particulars address
THE GREAT AMERICAN TEA CO.,
P. O. Box 289, 51 and 53 Vesey St., New York.

Scientific Apparatus.

J. GRUNOW,

621 Sixth Avenue, New York.
Established 1852.

MAKER OF

Microscope Stands, Oil Immersion Objectives and Abbe Condensers for Bacterial and Histological work, of Objectives, Camera Lucida and other accessory apparatus.

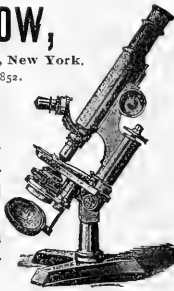

W. H. WALMSLEY & CO.

SUCCESSORS TO
R. & J. BECK,

1016 Chestnut Street Phila

Microscopes and all Accessories and Apparatus. Photographic and Photo-Micrographic Apparatus and Outfits.

Spectacles, Eye Glasses, Opera and Marine Glasses, etc.

Illustrated Price List mailed free to any address. Mention SCIENCE in corresponding with us.



IMPROVED OIL LIGHT MAGIC LANTERNS.

Also Lime and Electric Light Apparatus, and mechanical, plain, and fine colored views.

J. B. COLT & CO., Manufacturers,
No. 16 BEEKMAN STREET, NEW YORK.

MAGIC LANTERNS Stereopticons and the Best Views for Public, Church, Home, and Scientific Exhibitions. Best apparatus, new views. Largest stock. Reduced prices, 24 Years' Practical Experience. Illus. Catalogue Free.

GEO. H. PIERCE,
136 S. Eleventh St., Philadelphia, Pa

ELECTRICAL TESTING BUREAU,

Johns Hopkins University, Baltimore, Md.
Resistance Coils and Boxes Compared.
Am meters and Volt meters calibrated.
Condensers standardized.
Primary and Secondary Batteries Tested.
Efficiency of Dynamos and Motors Determined.
Insulation of Cables and Wires Tested.
Etc., Etc.
Circulars describing Methods Used, Prices, Etc., sent on Application.
Address as above.



E. & H. T. ANTHONY & CO.
591 Broadway, N. Y.

Manufacturers and Importers of PHOTOGRAPHIC INSTRUMENTS, Apparatus and Supplies of every description. Sole proprietors of the Patent Detective, Fairy, Novel, and Bicycle Cameras, and the Celebrated Stanley Dry Plates.

Amateur Outfits in great variety, from \$5.00 upward. Send for Catalogue or call and examine. ¹²⁷ More than 40 years established in this line of business.

WHITALL'S PLANISPHERES OR DIRECTORY OF THE STARRY HEAVENS name and locate all Stars, Constellations, and Planets visible at any given minute of time. Should be used by every one. Ask your stationer, or address **WM. T. COOPER, Manager,** 307 Race St., Philadelphia, Pa.

SCHOOLS AND COLLEGES will have a positive advantage by ordering their furniture apparatus and supplies from **C. PARDO & CO.,** 31 East 17th St., New York.

TO EMPLOYERS.

Having purchased the fixtures, good will, &c., of the **NEW YORK EMPLOYMENT BUREAU,** at No. 681 BROADWAY in this city, we request the patronage of the public in the future. We desire to fill a long-felt want for an employment bureau, where only the best grade of male help is dealt in, and it is our aim to send ONLY such help as is ordered in every instance, and our patrons can rely on us to send strictly first-class help, the references of whom we personally investigate before sending to any one. We simply request a trial, and are convinced that we will give satisfaction in every case. We have on hand help in every branch, which we can send upon receipt of telegram or letter, AND FOR WHICH WE MAKE NO CHARGE TO AN EMPLOYER.

NEW YORK EMPLOYMENT BUREAU,
(AS REORGANIZED).

Arnold, Constable & Co.

UPHOLSTERY.

NEW FABRICS
For Furniture, Curtains and Dec-
orations.

Ardmures and Arras Brocades.
TAPESTRIES AND GOBELINS.
"Flemish" plain and figured Galorine.
SILK AND COTTON PRINT STUFFS
For Wall and Interior Decoration.

Broadway & 19th St.
New York.

DRESS GOODS FOR SPRING

We are now exhibiting our Novelties in Dress Goods for Spring and Summer.

An extensive variety of fine wool and silk mixed fabrics, in new shades; Summer Tweeds, with handsome selvages; French Chevits with Shepherd Check side band; and many other new styles.

Advance styles in Figured Challie; India Silk in Exclusive designs; Mohair, Brilliantine and Pongee Gloriosa in a fine range of colors.

JAMES McCREERY & CO.
BROADWAY AND ELEVENTH STREET
NEW YORK.

SPECIAL TEACHER'S EXCURSION TO
PARIS EUROPE AND THE
WORLD'S EXPOSITION,
visiting England, France, Germany, the Rhine, Belgium and Holland. All travel and hotels FIRST-CLASS. Finest line of Steamers crossing the Atlantic. **Low Rates.** Rooms are being rapidly taken. Send for circular, free.
E. TOURJEE, Franklin Square, Boston, Mass.

FOOD ADULTERATION

And its Detection. With photomicrographic plates and a bibliographical appendix. By J. P. Battershall, 328 pages, 8vo, cloth. Price, \$3.50. Circulars and Catalogues on application. E. & F. N. SPON,
12 Corlandt St., New York.

A NEW MAGAZINE—THE SWISS
Devoted to spreading a love of
nature among the people. Edited
by HARLAN H. BALLARD, President of the Agassiz Association, and succeeding St. Nichol as the official magazine of that body. \$1.50 a year. Sample copy 10 cents, or 25 cents for trial subscription for 3 months.
N. D. C. HODGES, PUBLISHER,
Mention this paper. 47 Lafayette Place, New York.

EASTER CARDS BY MAIL.



All things young
and fair and sweet,
Come the Eastern-morn
to greet.

- We will send a complete set of the first six packages for \$3.50, and of the complete sets for \$5.00 and 50 cents for postage and registering, or to any one ordering \$5.00 worth of the above packets at one time, a \$1.00 packet will be sent free.
- No. 1.—For 50 Cents, and 4 Cents for Postage, 17 Prang & Co.'s and other fine Easter Cards, together with a handsome Birthday Booklet and a Lowell Calendar for 1889.
 - No. 2.—For 50 Cents, and 4 Cents for Postage, 10 large and finer Cards from the above publishers, with Card cut in form of an Easter Bell, and a Booklet Calendar by M. Ward & Co.
 - No. 3.—For \$1.00, and 6 Cents for Postage, a choice selection of 25 beautiful Cards of Prang's and Hildesheimer's, including a Souvenir Booklet (retail price, 35 cents) and a Satin Card and a Calendar.
 - No. 4.—For \$1.00, and 8 Cents for Postage, a selection of 10 of our largest and finest Cards, including an Easter novelty (retail price, 50 cents to \$1.00), or a Sonnet and Photograph from M. Hart or Beethoven or Haydn.
 - No. 5.—For 1.00 and 10 Cents for Postage 10 double Fringed Cards, each in a separate envelope, together with 2 handsome Cards of Children's Heads.
 - No. 6.—For 25 Cents, and 2 Cents for Postage, 10 Prang's, Tuck's, and other beautiful Cards, including a card cut in the form of a Cross.
 - No. 7.—For 50 Cents, and 4 Cents for Postage, 5 Easter Booklets and a Calendar for 1889.
 - No. 9.—BIRTHDAY PACKET. For 50 Cents, 17 Fine Cards of Prang's or Tuck's.
 - No. 10.—SUNDAY SCHOOL PACKET. For 50 Cents, 25 Cards, of Marcus Ward's, Prang's Cards, assorted.

STAMP OR POSTAL NOTES RECEIVED.
Pearl Cards, and other Novelties, at 15, 25, 50, 75 Cents and \$1.00 each for Birthday or Anniversary, which will be selected with care for different tastes and ages as specified.

TO TEACHERS ONLY
50 Marcus Ward's, Prang's, and other beautiful Cards, no two alike, for \$1.00 and 8 cents for Postage. Better assortment, \$2.00 and 10 cents for Postage. A very choice selection, no two alike, \$3.00 and 20 cents for Postage and Registering. And for 50 cents, and 4 cents for Postage, 25 Cards, no two alike, and a Calendar for 1889.

LOWEST PRICES IN THE UNITED STATES.
PAPER BY THE POUND. (no better or more elegant paper can be made). Common wealth Linen (a good medium priced linen paper), U. S. Treasury Bond (a tough paper, and very fashionable). Selling directly from mills to the consumer, we are able always to give lowest possible prices. Sample sheets of paper and envelopes, with prices and number of sheets to a pound, sent on receipt of 15 cents, and special prices to those taking orders for these papers with our card packets.

H. H. CARTER & CO., NO. 3 BEACON ST. BOSTON, MASS.

ESTERBROOK'S STEEL PENS.
OF SUPERIOR AND STANDARD QUALITY.
Leading Nos.: 048, 14, 130, 135, 239, 333
For Sale by all Stationers.
THE ESTERBROOK STEEL PEN CO.,
Works: Camden, N. J. 26 John St., New York.

Old and Rare Books.
A. S. CLARK, Bookseller,
34 PARK ROW, NEW YORK CITY.
A Gleaner in the By-ways of Literature. Results of Gleaning found in Catalogues issued from time to time.
CATALOGUE NO. 27, NOW READY.

BACK NUMBERS and complete sets of leading Magazines. Rates low. AM. MAG. EXCHANGE, Schenaric, N. Y.

H. WILLIAMS,
Magazines, Reviews, &c. Scientific
Nat. Museum Library
Smithsonian Inst. 28th St. N. Y.

KNABE
PIANOFORTES.
UNEQUALLED IN
Tone, Touch, Workmanship and Durability.
WILLIAM KNABE & CO.
NEW YORK: No. 112 Fifth Av., above 16th St.
BALTIMORE: Nos. 22 and 24 E. Baltimore St.
WASHINGTON: No. 817 Market Space, Penn. Av., near 9th St.



KIMBALL'S STRAIGHT CUT CIGARETTES
Unsurpassed in quality.
Used by people of refined taste.
Highest award at Brussels, 1888.
The finest smoking mixtures are of our manufacture.
Fifteen First Prize Medals.
WM. S. KIMBALL & CO.,
Rochester, N. Y.

Readers of Science
Corresponding with or visiting Advertisers will confer a great favor by mentioning the paper.

WHY YOU SHOULD USE Scott's Emulsion
OF Cod Liver Oil WITH HYPOPHOSPHITES.
It is used and endorsed by Physicians because it is the best.
It is Palatable as Milk.
It is three times as efficacious as plain Cod Liver Oil.
It is far superior to all other so-called Emulsions.
It is a perfect Emulsion, does not separate or change.
It is wonderful as a flesh producer.
It is the best remedy for Consumption, Scrofula, Bronchitis, Wasting Diseases, Chronic Coughs and Colds.
Sold by all Druggists.
SCOTT & BOWNE, Chemists, N. Y.

LIBRARY OF THE UNIVERSITY OF MICHIGAN
133421
MAR 30 1889
SERIALS ACQUISITION

SCIENCE

[Entered at the Post-Office of New York, N. Y., as Second-Class Matter.]

A WEEKLY NEWSPAPER OF ALL THE ARTS AND SCIENCES.

SEVENTH YEAR.
VOL. XIII. No. 321.

NEW YORK, MARCH 29, 1889.

SINGLE COPIES, TEN CENTS.
\$3.50 PER YEAR, IN ADVANCE.

THE SUBMERGING MONITOR CRUISER.

THE calls for models and designs of battle-ships and other war-vessels issued at various times by the Navy Department have resulted in the collection of many valuable plans and much data that will tend toward the construction of a navy of which the country may justly feel proud. Among the designs submitted that possess some novel features is that of Hon. J. R. Thomas, United States Representative from Illinois. It is intended in this vessel to com-

This cruiser is 235 feet in length, with a beam of 55 feet. She displaces 3,030 tons on a draught of 14½ feet. One great point to be observed by war-vessels intended for service on our coast is that of keeping the draught as small as possible, in order to insure the entry of these vessels into our ports on the south-eastern seaboard and the Gulf coast, many of which are so shallow that the heavy class of armored vessels at present afloat cannot enter. In this vessel the trouble has been overcome in a very great measure by keeping her draught inside of 15 feet. Her 7,500 horse-power

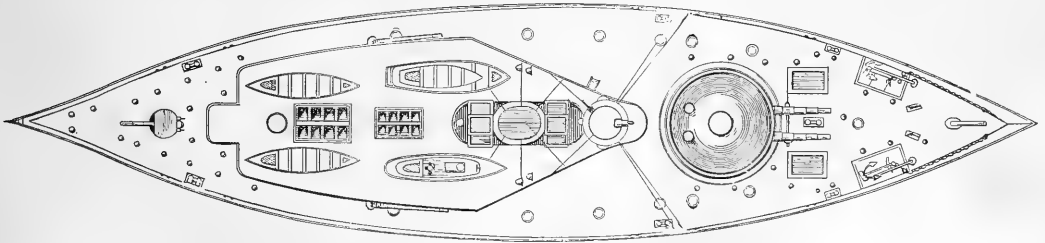
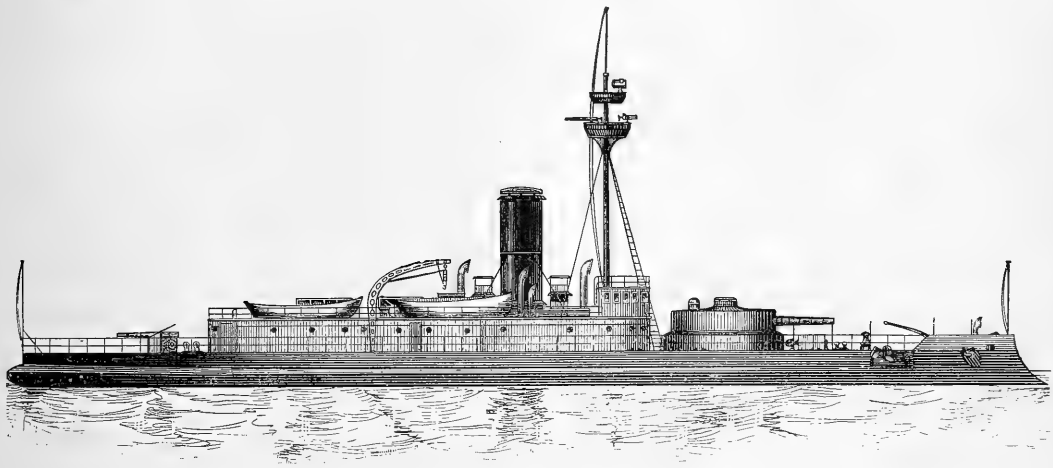

THE SUBMERGING MONITOR CRUISER.

bine large powers of offence and defence on as small an amount of displacement as is possible, recognizing that the efficiency of an armored vessel intended for ocean or coast purposes is to be measured by the disposition and character of her armament, the ability to use it in all reasonable weather, the protection afforded by the armor, the rate of speed both going ahead and turning, her cruising capacity without recoaling, and her habitability.

promises a speed of 17 knots, which may quite possibly be increased before the final plans are approved. The main battery consists of two 10-inch breech-loading rifles mounted in a turret, armored with 10 inches of steel plating. There is, in addition, a 15-inch Zalinski dynamite gun capable of throwing 800 pounds of high explosive at any distance within a range of two miles. There are two under-water bow torpedo-tubes, and a 6-inch rapid-fire gun on

the after deck. To these are added several rapid-fire guns of the smaller calibers, placed at the most commanding positions about the vessel. Her single military mast, in addition to the armored top, carries a powerful search-light mounted on an upper platform.

To give as great an armor protection as possible on a very limited displacement, the armor has been disposed in the form of an arc of a circle, turning downwards at the sides to four feet below the fighting-line. The armor on the crown is three inches in thickness, increasing to five inches at the sides. In order that the target presented to an enemy may be as small as possible, ballast-tanks have been provided capable of holding enough water to lessen the cruising freeboard three feet; so that the hull target exposed, in still water, will be represented by a segment of a circle, rising from zero at the water-line to four feet above at the centre of the vessel.

Particular attention has been paid to the subject of water-tight compartments, and the appliances for readily freeing them from water, both in case of accident and for restoring her to the normal line of floatation.

The ram bow with which this vessel is fitted, the speed that she is calculated to attain, and her handiness, all combine to render her a formidable and valuable addition to our seacoast defences, while her coal capacity, and ability to remain at sea at a 10-knot speed for over a month without recoaling, make her of the highest service as a cruiser.

Great care has been bestowed on the subject of light and ventilation below. A complete electric plant, comprising lights, fans, and blowers for ventilating, with all modern improvements, will undoubtedly do away with many of the ills that prevailed aboard former types of low-freeboard ironclads.

TOBIN BRONZE.

THIS alloy, manufactured by the Ansonia Brass and Copper Company, New York and Chicago, is attracting attention on account of its high elastic limit, tensile strength, toughness, and uniform texture. When rolled hot, the tensile strength of the bronze has been found to be greater than that of mild steel, certain tests showing for the bronze an average tensile strength of 79,600 pounds per square inch, and for steel 65,630 pounds; the elastic limits being 54,257 pounds and 36,510 pounds respectively.

Further, at a dead red heat, Tobin bronze can be forged and stamped as readily as steel. It is maintained by those who have experimented with and tested different kinds of metals with a view of determining their utility for forgings, that they find Tobin bronze to be the only bronze they have tried that will stand the process of drop-forging.

The alloy is lighter than copper, can be worked well in a lathe, and when finished has a bright golden color. Its freedom from blow-holes, durability, and anti-frictional properties adapt the bronze for use on all bearing surfaces; while its lightness, in addition to its great tensile strength, and resistance to the corrosive action of sea-water, renders it a suitable metal for condenser-plates, steam-launch shafting, ship sheathing, etc. When rolled in sheets and tempered or drawn in wire, it makes an excellent spring metal.

Its resistance to oxidation makes it a useful material wherever this is likely to occur. Some interesting experiments on this very point were made with the bronze by the inspectors of machinery of the United States steamers "Concord" and "Bennington."

With a view to determining its torsional endurance for steam-launch and yacht shafting, test specimens an inch long were cut at random from three-fourths-inch hot rolled rods, reduced to half an inch, and subjected to a torsional test in comparison with the best quality of machinery steel selected by Professor J. E. Denton, professor of experimental mechanics at Stevens' Institute, and tested by him on Thurston's autographic testing-machine. The results were as follows: average load at end of one-foot lever, which strained samples to elastic limit, for bronze 328 pounds, for steel 340 pounds; which ruptured samples, for bronze 633 pounds, for steel 711 pounds.

Another notable quality — its non-liability to give forth sparks — makes it invaluable for gunpowder machinery and gunpowder tools of every description.

A LARGE ELECTRIC-CURRENT CONDUCTOR.

A NEW departure in current conductors for electric-railway purposes has been taken by the Daft Company, who are now operating trains on a section of the Ninth Avenue Elevated Road in this city. The new kind of conductor is shown in the accompanying picture, which is a view on the road mentioned, looking south from Fourteenth Street. The conductor, which is supported by heavy insulated cast-iron brackets, runs along outside the outer guard-rail of each track. It is of round iron, three inches in diameter, and is surmounted by, and in perfect electrical contact with, a bar of phosphor bronze three-eighths of an inch thick by one inch wide. This bar takes all the wear from the contact apparatus, and will retain a polished surface under all circumstances. The supporting bracket is made in two parts, as may be seen in the illustration, and has a grip sufficient to prevent all possibility of displacement

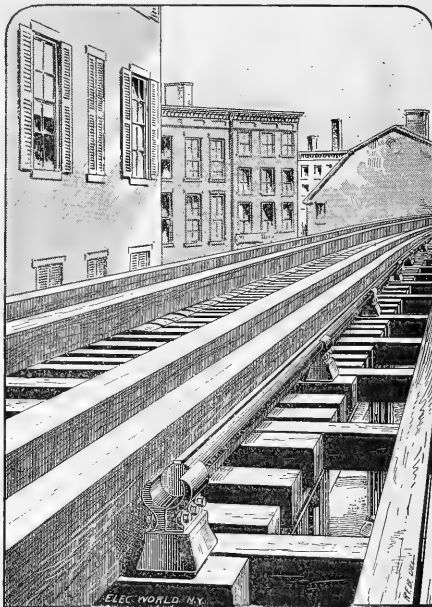

NEW DAFT CONDUCTOR, NEW YORK ELEVATED ROAD.

of the conductor. The conductor is elevated a considerable distance from the ties, and the supporting brackets are well insulated, so that the chances of loss of electric energy through leakage are reduced to a minimum.

The difference in cost of iron and copper admits of the greatly increased size of conductor, giving the same conductivity at much less expense.

The Daft Company are now equipping the Ninth Avenue road with this conductor from Fourteenth Street south to Rector Street station, near the Battery; the success attending the running of their trains north from Fourteenth Street during the past winter encouraging them to extend operations and equip a greater length of track as rapidly as possible.

A METEOROLOGICAL EXHIBITION.

SEVERAL months since, the New England Meteorological Society, following the annual custom of the Royal Meteorological Society of London, decided to hold a loan exhibition in Boston in connection with its fourteenth regular meeting. The exhibition was opened in the physical laboratory of the Massachusetts Institute of Technology, Jan. 15, and was continued seven days. Among those who sent apparatus were Mr. Rotch from his Blue

Hill Observatory, the United States Signal Office, Harvard College Observatory, the Institute of Technology, the Boston Water Works, and the Draper Manufacturing Company of New York. Owing to the generous response to the circular requesting the loan of articles, particularly by the United States Signal Service, the exhibition was a success, and was so well attended by visitors that it was continued three days longer than was originally intended. Now that the feasibility of such an exhibition has been demonstrated, it is to be hoped that others will follow, as there can be no doubt of their effect in stimulating the study of meteorology.

THE HORNIG DIRECT-POWER STEERING SYSTEM.

THE steering system herewith illustrated is the invention of Julius L. Hornig of Jersey City, N. J. It may be operated by steam, hydraulic, or pneumatic pressure, the last being preferable. The motor is attached directly to the rudder-head, as shown in the

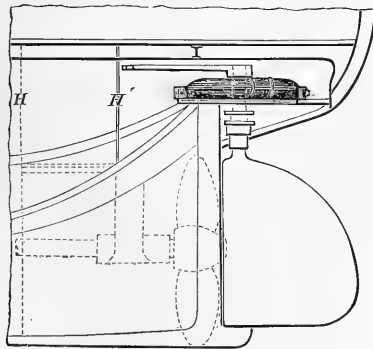
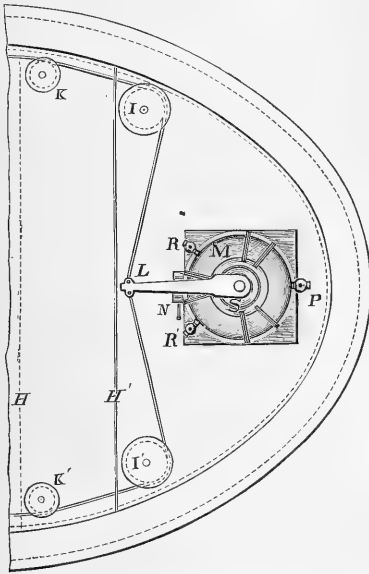

FIGS. 1. AND 2.

illustrations, though a special form of the motor is made which may be placed in any convenient part of the vessel, connecting with the rudder by chains, ropes, or rods.

The motor is shown at *M* in Figs. 1 and 2, the usual tiller, *L*,

not being removed, so that the vessel may be steered by hand if necessary. In fact, either hand or power steering may be done, or both at once, as neither system interferes with the other. *I* and *K* are guide-pulleys for the usual tiller-ropes. *R, R* are relief-cocks, and *P* is a regulator-cock for the brake.

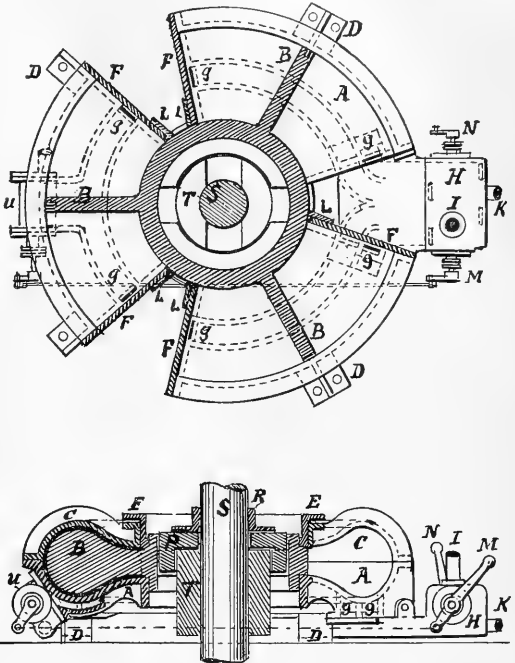

FIGS. 3 AND 4.

The motor has three pistons, working in an annular chamber, as shown in Figs. 3 and 4. *A* and *C* are the bottom and top cases of the chamber; *B*, the pistons; *D*, the legs by which the motor is secured to the deck; *g*, the ports; *H*, the valve-chest; *I*, the inlet-pipe; and *K*, the outlet-pipe. *M* is a lever for working the regulator-valve *U*, and *N* is the main valve-lever. *S* is the rudder-head; *T*, the motor hub; and *F*, the end covers or abutments.

The reason for preferring pneumatic pressure to operate the motor is that liquids have practically no elasticity, and may freeze, while steam will condense. Air, on the other hand, is subject to no change; and its elasticity makes it an excellent cushion to receive the shocks of wave-blows, thus relieving the mechanism from sudden strain. In 1886 two boards of naval experts, acting under government instructions, made trials of pneumatic steering-gear, and reported its superiority over other methods.

The pressure-valve, which is operated by the lever, as shown in the cut, regulates the action of the pistons by supplying pressure to one side while relieving that on the other, or *vice versa*; while the pistons and rudder will remain stationary when the valve is kept closed. The motor may be controlled from any part of the vessel by any of the usual mechanical methods or by electrical transmission.

PROFESSORS AYRTON and PERRY announce that Messrs. J. W. Queen & Co. of Philadelphia, Penn., are alone authorized to sell their electrical measuring instruments in the United States and in Mexico, and all instruments sent to America which have satisfactorily passed their tests will bear the firm's name on them as American agents, as well as being accompanied by a certificate of accuracy.

PLATINUM.

THE *Engineering and Mining Journal* calls attention to a renewed demand during the last year or so for crude platinum, or "platinum sand," and gives a summary of the localities where the metal can be found in this country. There are so many localities in this country where it has been found, that it seems reasonable to believe that a regular platinum-mining industry may at some time be established, perhaps, independently of placer gold-mining.

The placer mines of California, Oregon, and other States and Territories, have shown a large number of localities in which platinum occurs. Small lots have come into the market from many of them, and the number would doubtless have been greater had the miners known that the crude metal could be sold in very small quantities. While aware that their "black sand" contained platinum, it seemed hardly worth while to take the trouble to collect the ounce or so of metal which might be obtained at a clean-up.

Now that hydraulic mining in California has received such a setback from invidious legislation, the quantities of platinum found, or to be found, are naturally less than before. Still the known localities, where gold-mining is still carried on by the hydraulic process, or by sluicing from drift or cement mines, are not few.

It is very possible that some arrangement of the undercurrents, by which a larger quantity of black sand would be collected with the amalgam, might be profitable. Whenever grizzlies are used, the addition of screens, placed below, might be an improvement. The platinum grains are, as a rule, in better shape for concentration than particles of gold, and they do not flour like amalgam.

In cleaning up the main line of sluice in placer mines showing platinum, if pains were taken to collect a comparatively large amount of the heavy material, — "black sand," etc., — this, together with the savings from the undercurrents, might be run over some mechanical concentrating apparatus, such as a vanner, with a production of platinum which would pay for the extra trouble.

But there are possibilities of finding platinum in other than gold-mining regions. Of course, wherever the metals occur together, any method of saving gold by gravity will also result in the saving of platinum, if present; and when amalgamation is the principal dependence, as in ordinary sluicing, still gravity is mainly relied on, even if plates are also used, to hold or to catch the amalgam, and therefore any platinum which may be present. It may be, however, and very probably too, that there are localities which have been prospected for gold and abandoned as unprofitable, which would furnish platinum in commercial quantities. The association of the two metals is by no means a necessary condition. That they are in practice found together, simply means that a gravity process which saves the one saves also the other. It is therefore worth while for prospectors exploring new fields to keep an eye open for platinum.

The same journal is authority for the statement that within the last few days a noteworthy discovery has been made: platinum has been found *in place* in the nickeliferous ore of Sudbury, Canada, by Professor F. W. Clarke. This discovery was made accidentally, in the course of determinative and analytical work upon the ore, which presents other peculiarities. While the amount found is of little or no commercial importance, it has a very great scientific significance, and is certainly something new. Platinum grains have been found in secondary rocks, such as recent sandstones, conglomerates, etc.; but never before, so far as we are aware, in vein stuff, although it has long been looked for, and such an occurrence was to be expected. There is therefore always the chance that actual veins of platinum-bearing material, so often falsely reported, may actually be found, and that perhaps some of them may be of a paying grade. The number of localities, and their wide distribution, in this country, point to such an outcome.

THE HISTORY OF PORPHYRITIC QUARTZ IN ERUPTIVE ROCKS.

In a very suggestive communication with the above title, presented to the Philosophical Society of Washington, Saturday evening, March 16, Mr. J. S. Diller emphasized the distinction first clearly drawn by Rosenbusch between granitic and porphyritic quartz in eruptive rocks.

Granitic quartz, he remarked, is the last mineral to solidify, as may be well seen in such rocks as granite, where it fills the angular spaces between the crystals of feldspar and other silicates.

On the other hand, porphyritic quartz is characterized either by a well-developed crystallographic outline or by rounded or embayed forms derived from such crystals by the corrosive action of the molten lava in which they were suspended. The destructive forms are by far the most common, and their distribution indicates that porphyritic quartz crystallized in the magma at great depths beneath the earth's surface before the majority of the silicates with which it is associated were formed. Mr. Diller laid special stress on the fact, that, while the silicates are crystallizing in a molten mass, if porphyritic quartz is present it undergoes resorption; and not until the silicates are developed, and granitic quartz begins to form, does the resorbent action discontinue.

Mr. Diddings was quoted as having shown that the crystallization of porphyritic quartz is not determined by the chemical composition of the magma, but due to physical conditions; and the speaker agreed with Lagorio, also, that the resorptive phenomena of porphyritic quartz and other minerals in eruptive rocks is a consequence chiefly of the relief of pressure in the process of eruption.

To explain the crystallization of silica as porphyritic quartz, right in the face, so to speak, of the iron, magnesia, and other bases which, as we would suppose, were thirsting for the silica to form silicates, Mr. Diller advanced a novel hypothesis as to the influence of pressure on the crystallization of minerals in deep-seated magmas.

Reasoning from the results of Hallock's observations (*Science*, xi. p. 152) and other data, he concluded that an increase of the pressure, already enormous, upon the magmas within the earth, only removed them further from crystallization, instead of producing it, as has been suggested by some petrographers.

At a considerable depth beneath the earth's surface the pressure upon the magma is so enormous, and the difficulty of moving the molecules among themselves so as to segregate those of a certain kind and arrange them in crystals is so great, that the crystallizing force, which has a comparatively small limit of strength, is unable to overcome the resistance, and crystallization is wholly prevented. Thus it would appear that the interior of the earth is maintained in an amorphous condition by pressure alone, and only a comparatively thin crust allowed to crystallize. It would follow from this view that the crystallization of the magma within the earth is rendered possible only by the relief of pressure; and the minerals which could crystallize first (and they are similar in all lavas) must be determined to a large extent by the relative strength of their crystallizing forces. As a consequence of the gradual relief of pressure, it would be expected that simple minerals such as the oxides, of which quartz is one, could crystallize before the more complex silicates. A further relief of pressure may enable the silicates to form, and, in the struggle for silica, the quartz is partially or wholly resorbed. If the rock cools slowly, and becomes holocrystalline, any silica that is left over after the bases in its neighborhood are satisfied will fill out the irregular spaces between the crystals of silicates, and form granitic quartz.

The production of twinning lamellæ in many minerals, of rocks which have been subjected to high pressure, was regarded as a step in the direction of reducing crystallized matter to an amorphous condition.

The full paper, which is only an abstract of a forthcoming bulletin of the United States Geological Survey, will probably be published in the "Proceedings of the Philosophical Society."

ETHNOLOGY.

The Man of Spy.

At a recent meeting of the New York Academy of Sciences, Professor J. S. Newberry described the important finds of human remains in a cave at Spy in Belgium, which were made in 1887, and illustrated his lecture by interesting photographs of the crania and other portions of the find. Since the discovery of the Neanderthal man, no other discovery of equal importance has been made; the more so, as Messrs. Ed. van Beneden and Ch. van

Bambeck, who have submitted the remains to a careful and thorough examination, arrive at the conclusion that the man of Spy, that of Neanderthal, and that of Canstadt were of the same race, and possessed certain characteristic features which they consider as pithecoïd. The following figures are taken from the report of these gentlemen, and show that there really exists a striking similarity between the Neanderthal and the Spy skulls. The authors sum up their researches on the anatomical character of the remains as follows: "To sum up, we believe that we can advance the opinion, founded solely on the anatomical character of the man of Spy, that he possessed a greater number of pithecoïd features than any other human race. These features are the following: the superciliary arches and the frontal sinus are strongly developed; the forehead is low and retreating; the occipital prominence is large; the region of the chin is of very small size; the marked prognathism and the central elevation of the row of teeth, beginning at the canine teeth; the curvature of arm and leg; the small size of the tibia; and the bearing of the man when standing upright." The authors add that these peculiarities are far more exaggerated in the anthropoid apes than in the case of this man. The other features of skull and body are entirely human.

"Between the man of Spy and the ape there is still an enormous

J. Ranke sums up the interesting history of this skull as follows: "It is remarkable how rapidly and completely the views expressed after the first discovery of the skull were refuted. Although we are unable to concur with Darwin's views, who called the Neanderthal skull well developed and capacious, the researches of Virchow, Spengel, and others proved that the general form of the cranium—chamæcephalic dolichocephalic—was widely spread in ancient and modern times in the region in which the skull was found, but especially in Friesland. At the Anthropological Congress of Brussels, Dr. Hamy maintained that he had seen in the streets people with skulls of the same type. Other scientists had seen similar shapes of skulls in various parts of Europe. Virchow proved that a number of the peculiarities of the skull under discussion were due to pathological processes. At a young age the Neanderthal man had been afflicted with rachitis; in old age he had suffered from gout. The latter seems to have been very frequent at this period, and may have been due to life in the damp caves. Cave bears have been frequently a prey of the disease. Besides this, traces of various lesions are found. Virchow sums up his views, saying that the whole form must have been modified by these pathological processes, which he describes in detail."



1. SIDE VIEW OF CRANIUM FROM SPY, NO. 1; 2. SIDE VIEW OF CRANIUM FROM SPY, NO. 2; 3. SIDE VIEW OF NEANDERTHAL CRANIUM. (1-6 NATURAL SIZE.)

gap. In comparing the race of the Neanderthal to those which have made their appearance later on, — that of Cro-Magnon, the race of Furfooz, the neolithic races, and those of the present time, — we observe that the pithecoïd features have diminished constantly, and that they disappear one after another. Some of them may still be found in one or the other of the lowest races: they may re-appear by atavism individually among Europeans. It might well be that such a feature could re-appear more prominently than it does in the case of the man of Spy; but the grand total of so great a number of pithecoïd features is impossible except in the case of the most ancient race known up to this time. Besides this, we believe we have shown that the Chélléan man, the predecessor of the man of Neanderthal and Spy, who led a nomadic life without shelter and habitation, who chipped the paleolithic flints, the contemporary of *Elephas antiquus* and *Rhinoceros Merckii*, is unknown to us so far as his anatomical character is concerned. The manufacture of the pliocene stone implements of Montaperto, of the upper miocene in Italy, of the upper miocene of the Tagus valley in Portugal, are also unknown to us.

"If the most ancient ethnic type that is known to us was capable of assuming modifications during the quaternary sufficient to give rise to races of as different a character as those of Cro-Magnon and Furfooz, if during this period it could lose numerous inferior features and gain others instead, it is not difficult to assume that pliocene man was far inferior to the man of Spy. It is true, the distance separating the man of Spy from the recent anthropoids is enormous, but it is smaller between the same man and the *Dryopithecus* of the middle miocene of St. Gaudens; but, on the other hand, the ethnic type of the man of the lower quaternary had to be modified considerably to assume the character of the present races, if he really was their ancestor."

Although the authors' views will not remain unchallenged, the results of their thorough measurements are well worthy of a careful consideration. But it will be well to remember the history of the famous Neanderthal skull, which was, when first discovered, believed to be much more pithecoïd than the men of Spy are now described.

Regarding another skull of the same age, that of Engis, which is classed with the skull of Neanderthal, Huxley says that it might well have been that of a great philosopher.

These facts make us loath to accept unhesitatingly the views expressed by the Belgian authors. Skulls are known from the Old World as well as from the New World, which, if found in a position suggesting old age, would be classed with these undoubtedly early quaternary skulls. The figures reproduced above are unfortunately not orthogonal tracings, but outlines of photographs. Orthogonal views make the crania appear considerably higher, as may be seen from the following figure, showing the Neanderthal



skull in solid lines as drawn by Huxley by means of the camera-lucida, while the broken line is a geometrical (orthogonal) projection made by Th. Lanzert.

The fortunate find of Spy contributes materially to the final solution of the ethnic character of the early races of Europe, and is a most welcome supplement to the finds of Neanderthal.

BEANS CULTIVATED IN PREHISTORIC ARIZONA. — A number of years ago Mr. Wittmarck expressed the opinion that our bean (*Phaseolus vulgaris*) was not a native of the Old World, as was usually assumed, but that it was an American plant. This view, which was founded on finds made in Peruvian burials, was later on confirmed by researches of Körnicke, Asa Gray, and Hammond Trumbull. Recently Mr. Wittmarck has discovered seeds of the bean among the excavations of the Hemenway expedition in

Arizona, which were exhibited by Professor Edward S. Morse and Sylvester Baxter during the recent Congress of Americanists at Berlin. This discovery confirms the American origin of the bean. The plant called *phaselos*, *faseolus*, etc., in antiquity, is, according to Körnicke, *Dolichos chinensis*, or a variety of the species *D. melanophthalmos*. Mr. Wittmarck has found also seeds of the pumpkin in ancient Peruvian burials, and concludes that the pumpkin is originally an American plant. The so-called pumpkins of the Bible are, according to Ascherson and Magnus, melons (*Cucumis Chate L.*), and so are those represented on ancient Egyptian paintings. On the other hand, Gray and Trumbull have proved that before the arrival of the Europeans, pumpkins were used as far north as northern New York.

ELECTRICAL NEWS.

Electrical Lines of Force.

THIS subject was brought before the members of the Royal Institution, London, some years ago by Mr. Gordon; and recently a lecture was delivered on the same subject at the institution by Professor A. W. Rücker, an abstract of which appears in *Nature* of March 7. In the interval a considerable amount of work has been done upon it, both in England and Germany, and many experiments have been devised to illustrate it. Some of the more striking of these, though of great interest to the student, are rarely or never shown in courses of experimental lectures. The lecturer and Mr. C. V. Boys, F.R.S., last year devised a set of apparatus which has made the optical demonstration of electrical stress comparatively easy, and most of the results obtained by Kerr and Quincke can now be demonstrated to audiences of a considerable size. Before discussing this portion of his subject, the lecturer introduced it by an explanation of principles on which the experiments are founded.

Magnetic lines of force can easily be mapped out by iron filings, but the exhibition of electrical lines of force in a liquid is a more complex matter. In the first place, if two oppositely electrified bodies are introduced into a liquid which is a fairly good non-conductor, convective conduction is set up. Streams of electrified liquid pass from the one to the other. The highly refracting liquid phenyl thiocarbamide appears to be specially suitable for experiments on this subject. If an electrified point is brought over the surface, a dimple is formed, which becomes deeper as the point approaches it. At the instant at which the needle touches the liquid the dimple disappears, but a bubble of air from the lower end frequently remains imprisoned in the vortex caused by the downward rush of the electrified liquid from the point. It oscillates a short distance below the point, and indicates clearly the rapid motions which are produced in the fluid in its neighborhood. When the needle is withdrawn, a small column of liquid adheres to it. This effect is, however, seen to greater advantage if a small sphere about five millimetres in diameter is used instead of the needle-point. When this is withdrawn, a column of liquid about five millimetres high and two millimetres in diameter is formed between the sphere and the surface. A similar experiment was made by Faraday on a much larger scale with oil of turpentine; and he detected the existence of currents, which are in accord with the view that the unelectrified liquid flows up the exterior of the cylinder, becomes electrified by contact, and is repelled down its axis. In view of this explanation, and the movements assumed can be clearly seen in the phenyl thiocarbamide, the performance of the experiment on a small scale is not without interest. The possibility of the formation of such violent up-and-down currents in so small a space must depend upon a very nice adjustment between the properties of the liquid and the forces in play. It is obvious that such movements of the liquid must be a disturbing element in any attempt to make the lines of electric force visible.

Again: if a solid powder be suspended in a liquid into which electrified solids are introduced, it tends to accumulate round one of the poles. This subject has been investigated by W. Holtz. Sometimes the powder appears to move in a direction opposed to that in which the liquid is streaming. Sometimes two powders will travel towards different poles.

If powdered antimony sulphide be placed in ether, it settles at the bottom of the liquid; and if either two wires insulated with glass up to their points, or two vertical plates, be used as electrodes, on exciting them slightly the solid particles arrange themselves along the lines of force. If the electrification be increased, they cluster round the positive pole. On suddenly reversing the electrification by means of a commutator, they stream along lines of force to the pole from which they were previously repelled. Other methods of obtaining the lines of force have been devised. They can, for instance, be shown by crystals of sulphate of quinine immersed in turpentine.

The tendency of the lines of force to separate one from the other was illustrated by Quincke's experiment. A bubble of air is formed in bisulphide of carbon between two horizontal plates. It is in connection with a small manometer, and when the plates are oppositely excited, the electrical pressure acting at right angles to the lines of force, being greater in the liquid than in air, compels the bubble to contract.

Kerr's experiments depend upon the fact, that, since the electrical stress is a tension along the lines of force, and a pressure at right angles to them, a substance in which such a stress is produced assumes a semi-crystalline condition in the sense that its properties along, and perpendicular to, the lines of force are different. Light is therefore transmitted with different velocities, according as the direction of vibrations coincides with, or is perpendicular to, these lines; and the familiar phenomena of the passage of polarized light through crystals may be imitated by an electrically stressed liquid.

The bisulphide of carbon used must be dry, and, to make the phenomena clearly visible, it is necessary that the light should travel through a considerable thickness. Thus, to represent the stress between two spheres, elongated parallel cylinders should be used, the axes of which are parallel to the course of the rays of light. These appear on the screen as two dark circles. Between crossed Nicols, the planes of polarization of which are inclined at forty-five degrees to the horizontal, the field is dark until the cylinders are electrified, when light is restored in the space between them.

If parallel plates with carefully rounded edges, and about two millimetres apart, are used, the colors of Newton's rings appear in turn, the red of the third order being sometimes reached. If one plate is convex towards the other, the colors of the higher orders appear in the middle, and travel outwards as the stress is increased. The experiments may be varied by using two concentric cylinders, or two sheets of metal bent twice at right angles to represent a section through a Leyden jar. In the first case a black cross is formed; and in the second, black brushes unite the lower angles of the images of the edges of the plates. By the interposition of a piece of selenite, which shows the blue of the second order, two of the quadrants contained between the arms of the cross become green, and the others red. In like manner the horizontal and vertical spaces between the inner and outer coatings of the "jar" become differently colored.

There are several phenomena connected with the stress in insulators which present considerable difficulties. Thus in a solid it is found impossible to restore the light between crossed Nicols by a uniform electrical field. That the non-uniformity of the field has nothing to do with the phenomenon in liquids, though at first disputed, is now generally admitted. It may be readily proved by means of a Franklin's pane, of which half is pierced into windows. The glow is much weakened by thus removing part of the uniform field, though it is thus made much less uniform.

Again: though most dielectrics, when placed in an electric field, expand, the fatty oils contract. Professor J. J. Thomson has recently pointed out that this indicates that another set of strains are superposed upon those assumed in the ordinary explanations of these phenomena, and by which they may be neutralized or overcome.

In experiments with carbon bisulphide it is necessary to take every precaution against fire. For this purpose the cell which contains the liquid should be immersed in a larger cell; so that if, as sometimes happens, the passage of a spark cracks the glass, the liquid may flow into a confined space. This should stand in a tray

with turned-up edges, and an extinguisher of tin plate should be at hand to place over the whole apparatus. No Leyden jars should be included in the electrical circuit. The difficulties which formerly arose in the exhibition of experiments in static electricity, owing to the presence of moisture in the air of a lecture-room, are now immensely reduced by the Wimshurst machine, which works with unfailing certainty under adverse conditions. A new and very beautiful machine was kindly lent by Mr. Wimshurst for the purposes of the lecture.

ARC-LAMP FOR INCANDESCENT CIRCUITS.—The Silvey Electric Company, Lima, O., claims to have the only arc-lamp that can be depended on at all times for incandescent circuits. In this lamp it is impossible to cross the carbons or cause a short-circuit. The lamp has a rack feed-rod fed by a mechanism which makes it impossible for the carbons to approach each other more than one two-hundredth part of an inch at a time, thus maintaining the light steady at all times, while it is impossible for the two carbons to drop together. The light may be turned on or off at will, and the company guarantee the lamp to burn perfect upon any system of incandescent lighting, and to not interfere with the incandescent lights. Persons having incandescent machines often want an arc-lamp or two for yards or large open places. This lamp meets this want, and is arranged to burn on the Edison, Mather, Thomson-Houston, United States, and other incandescent machines. It takes the same amount of power as ten incandescent lamps, giving a return of two thousand nominal candle-power. A patent was issued to William L. Silvey, March 5.

DYNAMO-DESIGNING.—At a meeting of the Engineers' Club of St. Louis, March 20, Professor Nipher addressed the club on "Plans of Investigations in Dynamo-Designing." His remarks were illustrated by numerous drawings, and by formulæ and sketches on the blackboard. He explained in detail the principles involved, and showed how, when certain constants for any type of dynamo had been ascertained, the design of dynamo of the same type of any other desired capacity could be readily determined. He had recently made such a calculation for an Edison dynamo, which he used as an illustration. He gave two empirical formulæ for the safe carrying capacity of a wire in amperes. The cost of copper necessary in any dynamo, and the speed at which it could be run, were usually determining factors in the problem. Another important consideration is the resistance which the space around the dynamo offers to the magnetic line. It would be very desirable to have experiments made to determine this resistance for the prominent dynamos now in the market.

THE MAGNETIC ACTION OF DISPLACEMENT CURRENTS IN A DIELECTRIC.—Professor S. P. Thompson read before the Royal Society a few weeks ago an interesting paper on displacement currents. That there is an electric displacement in the dielectric of a condenser when the coatings are charged, and that any variation of this displacement causes effects analogous to those of ordinary electric currents, are points that have been indirectly proved by several experiments, notably those of Hertz. Thompson attempted at first to prove it directly by observing the effect on an astatic needle suspended near the edge of a condenser, of charging the condenser or of discharging it. But, as calculation showed that the effect would be too small to be observed, he adopted a different method. An iron annulus wound with a coil of fine wire was embedded in a layer of paraffine between two glass plates which were coated with tinfoil. The displacement passes through the iron ring, and any changes in the displacement should set up lines of magnetic induction in it; and these would cause currents in the fine wire circuit with which it was wound. The condenser was connected with an induction-coil; the fine wire, with a telephone. When the induction-coil was working, sounds were heard in the telephone, and it is held that this proves the existence of displacement currents. The method is extremely simple and ingenious; but one is led to ask if the reasoning that deduces from the experiment the existence of displacement currents does not depend on assumptions no better proved than the phenomenon experimented on.

PATENTS ON ALTERNATING-CURRENT TRANSFORMERS.—Some months ago the validity of the Gaulard and Gibbs patents in

England suffered an adverse decision of the courts, and the decision has just been affirmed by the Court of Appeal. In this country the Gaulard-Gibbs patents are held by the Westinghouse Company; and, although decisions of English courts do not by any means allow us to infer how the same case would be decided here, yet the result could not but be a blow to that company. As an indirect result of the trial, however, the Jablochhoff patents have been brought prominently forward; and as it is understood that the Jablochhoff patents in this country are owned by the United States Electric Lighting Company, and as the United States Company is controlled by the Westinghouse, the position of the latter corporation is not materially weakened by the English decision. M. Jablochhoff had granted him in 1877 a patent, of which one claim read as follows: "The use in apparatus for the production of electric light, of induction-coils, interposed in a primary electric circuit for generating separate and independent currents, to be used for producing electric light in one or more lamps interposed in such secondary circuits substantially as herein described." It is understood that the owners of the English patents have made arrangements with some of the leading electrical manufacturing concerns in that country by which the latter have been granted licenses under the patents.

THE TESLA ALTERNATING-CURRENT ELECTRIC MOTOR.—Almost a year ago Mr. Tesla read before the Institute of Electrical Engineers a paper on alternating-current electric motors, in which he described a motor of his own invention, which embodied several novel and ingenious features. The great novelty of the invention consists in the fact that the revolving armature is not connected with any external source of supply, but has currents induced in its coils by the variations of the magnetic field. The motor attracted a great deal of attention at the time, and its performance was enthusiastically praised. Professor W. A. Anthony made tests of the motor, but the only datum he gave was, that, "at 6,400 alternations, over one horse-power can be obtained at an efficiency of 62 per cent." As the measurement of the efficiency of such a machine would be extremely difficult, embodying some novel methods, and as no details of the methods employed or of the weight or speed of the motor were given, we can hardly consider Professor Anthony's statements as very satisfactory, and now we are again disappointed. A Tesla motor was sent to the Central Institution in London, and we had hoped that some tests would be made and published; but the only information so far obtained is a statement of Professor Ayrton that the motor gave .63 horse-power with 3,720 alternations at a speed of 3,200 revolutions,—quite an impractical speed for a commercial machine. The Tesla motor has been taken up by the Westinghouse Company, and there is no doubt that neither energy, nor money, nor talent are being spared to develop it. There is no doubt that it will work, and there is little doubt that it offers some advantages. At present it labors under the disadvantages of not being applicable with an ordinary alternating-current system, of requiring three wires instead of two, and of being possibly not so light or as efficient as a corresponding continuous-current motor. In a short article on the subject, the London *Electrical Review* concludes: "The weight of material used in a Tesla motor must be several times as much as that necessary for a continuous-current motor to give the same output, rendering such machines very costly. Thus it would appear that alternating-current motors are a long way off from the ideal goal, in spite of the strenuous efforts on the part of some of the smartest people in the world; and we are inclined to think that the solution of the problem may yet have to be sought in an entirely different direction." This is rather gloomy, and is hardly consistent with the fact that the subject has made rapid strides in the last year, and gives promise of an early solution of the whole question.

THE BIRMINGHAM ELECTRIC LOCOMOTIVE.—This locomotive is used for exceptionally heavy tramway work, and was designed to take the place of the steam-engines now in use. The motor weighs a ton, and the current for it is supplied from 100 storage-cells, weighing together four tons and a half. The cells are subdivided into four groups, which can be used either four in parallel, two in series, two in parallel, three in series, or four in series. The motor is suspended beneath the car, and is geared directly to both

of the axes. Some trials were made to determine the tractive force of this locomotive. It was coupled directly to one of the ordinary steam-locomotives of the Birmingham Tramway Company, and set to haul the latter. The brakes on the steam-locomotive were then gradually tightened until it was brought to rest, when the spring balance indicated a pull of a ton and a half; the current through the motor at that time being 200 amperes. Previous trials on the line had shown that the maximum pull was required on a six-per-cent grade, where it amounted to 1,800 pounds; so the electric locomotive has a margin of over 50 per cent of tractive power above that actually required in the ordinary working of the line. While it is to be hoped that the experiments in Birmingham will succeed, yet storage-batteries have hardly reached that state of perfection that they can compete, as far as expense goes, with steam-engines. While it is still a very doubtful question whether they are more economical than horses for street-car work, it would seem a mistake to bring them in direct competition with steam.

THE DIMENSIONS OF ELECTRICAL UNITS.—Professor Fitzgerald, in a note communicated to the Physical Society of London, calls attention to the fact that the dimensions of the electric and magnetic inductive capacities are the same, being the inverse of a velocity, the one differing from the other only by a numerical coefficient. This, Professor Fitzgerald thinks, is very suggestive, and seems to have been hitherto overlooked. He thinks that the two quantities must be proportional to the reciprocal of the square root of the mean kinetic energy of the ether.

A NEW DYNAMO.—Messrs. Fritsche and Pischon of Berlin have brought out a new wheel-armature dynamo which gives some remarkable results. The armature is built without a core, without cotton insulation, without copper, and without a special commutator construction. It is built up of a lattice-work of iron rods, which are separated by air-spaces, and the rods are prolonged as segments of the commutator. The dynamo is multipolar. The smallest of them gives 50 16-candle-power lamps, at a speed of 240 revolutions; the largest supplies 3,500 lamps at 70 revolutions. They are said to be very efficient, which fact, together with their extreme simplicity, will probably cause their extended adoption.

NOTES AND NEWS.

THE Ericsson Coast Defence Company was incorporated at Albany on Friday, March 22, by George H. Robinson, William Williams, Ericsson F. Bushnell, Cornelius S. Bushnell, and Edward S. Innet. The main idea of the company is to manufacture implements for the defence of the American coasts, and to enlist the interest and assistance of the United States Government in the results of the studies and experiments of the late Capt. John Ericsson, who devoted many years and much labor to the subject of our coast defences. The most notable of his inventions in this line is the "Destroyer," a boat built for the destruction of the monitor gunboats. The company claims that the boat has been satisfactorily tested, and believes that it will receive recognition from the present administration. With all the other inventions left by Capt. Ericsson, the Ericsson Coast Defence Company will have nothing to do; that is, with inventions which have nothing to do with the subject of coast defence. There are several of the latter inventions, notably a perfect calorific engine and the sun-motor, which the executors will proceed to patent at once, or at least as soon as they can act in the matter according to law. Owing to the legal advertising made necessary by the conditions of the will, that document cannot be probated before May. Every thing has to be turned into cash, and the necessary delay in communicating with the legates in Sweden and other parts of Europe will prevent for the present the patenting proposed by the executors. This delay, however, does not affect the operations of the Ericsson Coast Defence Company, which is wholly independent of the will and the legates.

—The collection of American precious stones, both in the form of crystals and cut stones, which are to be exhibited at the Paris Exposition, Messrs. Tiffany & Co. have decided to place on exhibition on Friday, Saturday, Monday, and Tuesday, March 29 and 30 and April 1 and 2. This collection is one of the finest that has

ever been gotten together, and will be in charge of Mr. George F. Kunz, who has devoted considerable time to its preparation.

—In *Nature* of March 7, J. Starkie Gardner writes as follows on the origin of coral islands: "Mr. Murray's concise explanation of the formation of coral reefs and islands presents advantages in more than one respect. It demands no *a priori* assumptions, but begins and ends with that which can be observed, while Darwin's theory requires the preliminary concession of subsidence, which never has been and never perhaps can be observed. It must appear ungracious to question a theory that accords so completely with the natural history of coral islands; but even this theory requires a geological concession, and that is stability. Coral islands, it may be supposed, after all, only differ from other oceanic islands in being crusted over with coral, so that we cannot see their original state; and the question is, whether we can grant such long periods of stability to them, from our experience of other oceanic islands, which are free from coral, and can therefore be observed. Nearly all oceanic islands are volcanic, and it is probable that their elevation coincides more or less with the period of volcanic activity somewhere along their line. It is obvious that coral islands are not formed during this phase, because no theory would then hold good; the peaks would grow through and carry up the coral, which might leave only such small traces of its existence as we find in a single spot in Madeira. It would not be unreasonable to suppose, that, if the expansive and elevating force were withdrawn, the peaks would slowly subside; and that, if there are some lines of elevation, there must be others of subsidence, unless the earth is as a whole growing in bulk. Darwin claims the existence of areas of subsidence, and that these are eminently favorable to coral-growth; and it is quite apparent that if the Island of Madeira were to sink, as it has undoubtedly risen, its last appearance in a coral sea would be as an atoll. We shall never see the interior structure of a stationary or subsiding coral island, and can only look for a re-elevated example with a crust that has been protected from solution whilst dead and submerged, and yet not sufficiently so to mask the core. In submitting geological considerations, I am not questioning any of Mr. Murray's observations, which are in every way admirable, though it does appear to me doubtful whether atolls could increase outwards in deep water on their own talus, in face of the dissolution of dead coral that is claimed to take place in the interior of the lagoons, and yet more so in deeper water."

—We note with pleasure the advancement to the grade of commander in the navy of Commander R. B. Bradford, who for the past few years has had complete control of the various electric-light instalments in our men-of-war and at the different naval stations. The unvarying success that these numerous plants have met with are well-deserved tributes to the abilities of the naval inspector of electric-lighting.

—Marcus M. Hartog, in *Nature*, writing of the inheritance of acquired characters, says, "A very strong *a priori* objection to the line on which most experiments on the inheritance of acquired characters are carried on is the following. These experiments involve mutilation; and a tendency to transmit characters so produced would, considering that every accident or fight produces some slight mutilation, involve the animals in a process of degeneration; hence the tendency to transmit the characters acquired by mutilation would be constantly bred out by natural selection. But a tendency to transmit characters acquired by habit in youth rests on quite another basis, and would tend to the conservation of the race. I do not know if observations have been made on the physique of the offspring of persons engaged in trades where apprenticeship begins before puberty: they would be most valuable. But the following case seems to me to be thoroughly to the point. A. B. is moderately myopic and very astigmatic in the left eye; extremely myopic in the right. As the left eye gave such bad images for near objects, he was compelled in childhood to mask it, and acquired the habit of leaning his head on his left arm for writing, so as to blind that eye; or of resting the left temple and eye on the hand, with the elbow on the table. At the age of fifteen the eyes were equalized by the use of suitable spectacles, and he soon lost the habit completely

and permanently. He is now the father of two children — a boy and a girl — whose vision (tested repeatedly and fully) is emmetropic in both eyes, so that they have not inherited the congenital optical defect of their father. All the same, they both have inherited his early acquired habit, and need constant watchfulness to prevent their hiding the left eye, when writing, by resting the head on the left fore-arm or hand. Imitation is here quite out of the question. Considering that every habit involves changes in the proportional development of the muscular and osseous systems, and hence probably of the nervous system also, the importance of inherited habits, natural or acquired, cannot be overlooked in the general theory of inheritance. I am fully aware that I shall be accused of flat Lamarckism; but a nickname is not an argument."

— At a meeting of the Physiological Society, Berlin, Feb. 1, Professor Moebius spoke on the movements of the flying-fish through the air. He first described, from personal observation, the way in which the fish shoot out of the water from both bows of the ship, and then propel themselves horizontally for a distance of several ship's-lengths with their pectoral and abdominal fins stretched out flat, skimming along without moving their fins, always in the direction of the wind, but either with or against the same. When they meet the crest of a wave, they raise themselves slightly in the air, falling again to the same extent in the succeeding trough of the sea. Occasionally a slight buzzing of the fins may be observed, similar to that of the movements of the wings in many insects. At night they frequently fall on the deck of the ship. As the result of a detailed investigation, the speaker had proved that these fish do not fly, since the anatomical arrangements of their fins and muscles are not adapted to this purpose. What really occurs is, that, when frightened by the approach of a ship or any enemy, they shoot out of the water, as do so many other fish, and are then carried along by the wind, which strikes on the under surface of their outstretched and evenly balanced fins. Notwithstanding the general acceptance which was accorded to the above investigation, it was urged by many that the buzzing of the fins, the rising over the crest of a wave, and the falling overboard after having landed on the deck of a ship, were evidences that this fish really executes movements which result in flight. In reply to this, Professor Moebius pointed out that the buzzing of the fins takes place when a strong current of air is directed against the outspread fins of a dead flying-fish by means of a bellows, and, further, that the rising over the crest of a wave or the bulwarks of a ship may be explained by the ascending currents of air which are always produced whenever a strong horizontal wind strikes against any elevated object such as a wave or part of a ship. Thus, finally, with the exception of the movements involved in its oblique sudden exit from the sea, all the motions of a flying-fish when in the air are really passive.

— It was claimed awhile ago for an elevator in the Wilder Building, Rochester, N.Y., that it had broken the record, and was the fastest in the country, having made the run from bottom to top, 126 feet, in $6\frac{1}{2}$ seconds, or at the rate of 1,163 feet per minute. The best previous record was said to have been that of an elevator in the Tribune Building, New York City, 110 feet in 8 seconds, or 825 feet per minute. Mere speed alone, however, does not afford sufficient data for a fair comparison, and gives little evidence of how fast an elevator can travel in actual use. The load is a most important item, and should always be stated, as in the following instances cited by *The Engineering and Building Record*, which will be found of interest in this connection. All are in New York City unless otherwise stated. The elevators in the Potter Building have travelled at the rate of 500 feet per minute with a load of 1,000 pounds in the car; those in Aldrich Court will travel about 600 feet per minute with the same load; and those in the Standard Oil Company's Building have made trips at an average speed of 720 feet per minute with 500 pounds in the car, and including the time of starting and stopping. The rise is 133 feet, and the time 11 seconds. What these elevators can do with an empty car, or with a light operator and no passenger, have never been determined. The fastest elevator probably now in existence is the "Water Balance" in the Western Union Building. This machine can attain a speed of certainly 1,000 feet, and probably 1,200 feet, per minute. Similar ones in Chicago, not now in use, are reported

to have reached 1,500 feet. This style of elevator is no longer made, not being as safe as the more modern types. The elevators which combine the greatest power and speed in New York City are probably those in the Produce Exchange, and their counterparts in the Cotton Exchange. These were contracted to lift 2,500 pounds in the car at a rate of 300 feet per minute, and did considerably better at the official trial.

— A substitute for granite blocks for paving purposes is a steel paving block claimed to have superior durability, and whose cost is said to be somewhat less than the stone. It is thus described in *The Engineering & Building Record*: The block is made of steel strips, some two inches and a half wide by one thick, with a rolled channel on the side exposed to traffic, and containing notches about half a foot apart. The weight of these strips is eleven pounds to the yard. They are laid across the street, a distance about five inches between centres; and, as their length is sufficient only to extend to the middle of the street, the proper slope from the centre to the gutters is easily secured. To insure their not slipping sidewise, they are bolted together, and fastened to wooden sills. The support for the new pavement is composed of a firmly constructed bed of gravel, while between the steel strips a compound of pitch and cement is poured, filling the interstices to a level with the tops of the strips, and rendering the surface comparatively smooth.

— *The American Field* is authority for the statement that wild boars have become very numerous in the deep recesses of the Shawangunk Mountains, that border Orange and Sullivan Counties, N.Y. They are the genuine Black Forest wild boars of Europe, the descendants of nine formidable and ferocious boars and sows imported by Mr. Otto Plock of New York, some few years ago, for the purpose of annihilating the snakes and vermin which infested his estate near the Shawangunk Mountains. After the boars had eaten up all the rattlers and vermin in the enclosure, they longed for more, and dug under the wire fencing and escaped to the mountains, where they have since bred and multiplied, and are so ferocious that the most daring hunter hesitates ere he "goes in for game." They have immense heads, huge tusks and shoulders, and lank hind-parts. They attack with a savage rush; and woe betide the hapless hunter who stumbles before one. Wild-boar hunting is greatly indulged in in Europe, and the accidental escape of these nine boars may furnish American Nimrods with sport on "big game" for many years, in the East. Buffalo hunting is not as dangerous as wild-boar hunting, and, as the element of danger is the spice of hunting to many, the Shawangunk Mountains will undoubtedly supply the East with sport the equal of any in the West.

— The shad fishermen of the Atlantic coast are all happy, and very busy preparing their nets and traps for the expected arrival of the vast schools of shad now steering for the coast from different parts of the Atlantic Ocean, this being the season of the year when they seek fresh water. This passion is well known by all shad fishermen; and, according to *The American Field*, thousands of feet of drift nets are being got in readiness on Staten Island, Long Island, along the Delaware, and all along the coast where rivers empty into the ocean. The New York fishermen lay for the shad as they attempt to pass through the Narrows, and are rewarded with tons of the delicious sea-food. The tides are such, however, that they can only work two hours out of six; and this in daytime only, for at night the boats of the fishermen are in constant danger of being run into by tugs and other steam-craft.

— At the meeting of the mineralogical section of the Brooklyn Institute, March 20, Mr. H. Hensoldt, in referring to his experiences as a naturalist in Ceylon, mentioned the fact that he had observed one of the stones carried in the mouth of the cobra-de-capello. This stone is phosphorescent, and the cobra has even been observed with its mouth open, the phosphorescent stone within it, for the purpose, it is believed, of alluring the mate of the firefly *Lamprolucania noctiluca*. This substance, Mr. George F. Kunz suggested, was evidently chlorophane, a variety of fluorite which emits a green phosphorescence on being heated. He stated that he had observed that the fluorite found at Amelia Court-house,

Va., would be caused to fluoresce by the heat of the hand, and that a similar variety had been described as occurring from Penandrea, Cornwall, England. He had cut a small stone of this substance, and had passed it around the rooms of the Academy of Sciences, the stone emitting a phosphorescence during the entire time. Mr. Kunz exhibited a copy of Sir Francis Reed's "Experimentalia Naturæ" (Amsterdam, 1685), which contained a plate showing eight of these so-called cobra-de-capello stones, to which were attributed the power of curing the bites of serpents and other venomous bites. Mr. Kunz also exhibited specimens of tabasheer, the variety of opal found in the joints of the bamboo, which strikingly resembled in its appearance, and also in its power of absorbing an equal weight of water, the variety of hydrophane described by him from a Colorado cavity, stating at the same time that the *oculus mundi* of the gem-writers of the sixteenth to the eighteenth century was evidently this tabasheer, which is powdered by the natives, and used as a medicine.

—C. O. Boutelle, H. L. Whiting, and B. A. Colonna, a committee of the assistants of the United States Coast and Geodetic Survey, announce, on behalf of themselves and their associates, that they intend to ask the President of the United States to appoint Dr. Benjamin Apthorp Gould of Cambridge, Mass., as superintendent of the Coast and Geodetic Survey. Dr. Gould is no stranger to the Coast Survey. From 1851 to 1868 he was attached to the work, and for nearly fourteen years was in general charge of all its telegraphic longitude parties. Between 1853 and 1867 eleven printed reports bear his name. The first telegraphic determination of the difference of longitude between Greenwich, England, and Cambridge, in New England, was under his general charge, and he personally superintended the observations at the eastern end of the cable, near Foilholerum, in Ireland. Soon after this last great work of 1866-67, he left the country to found an astronomical observatory, and educate native astronomers at Cordova, in the Argentine Republic. What he has done for astronomy in the southern hemisphere during the thirteen years of his stay there, has been well set forth in the "Proceedings of the National Academy of Sciences," at its session in April, 1888, in Washington, when the Watson gold medal was awarded to him for his distinguished and successful labors.

—At the Academy of Sciences, Paris, March 4, remarks accompanying the presentation of a work entitled "Introduction à l'étude de la Chimie des anciens et du moyen âge," were made by M. Berthelot. This work forms a sequel to the author's "Origines de l'Alchimie" and "Collection des anciens Alchimistes grecs," thus completing a series of historical researches which fully establish the true character of the old philosophic doctrines, methods, and practices, which were hitherto supposed to be mainly absurd and fanciful, but which must henceforth enter into the scheme of historical evolution of the positive sciences. Here M. Berthelot gives a full description and translation of the Leyden papyrus of Egyptian origin, the oldest extant treatise on chemistry. The signs, notations, and appliances of the ancient alchemists are also described and reproduced by the photogravure process.

—Capt. Moore, of H.M.S. "Rambler," has lately described in a paper read before the China Branch of the Royal Asiatic Society, and summarized in *Nature*, the appearance and effects of the remarkable "bore" which often occurs in Hangchow Bay. This dangerous visitor is the result of the struggle between the advancing tide in the great estuary and the current of the river. Capt. Moore and his officers on several occasions observed the progress of the wave, and their investigations may be summarized as follows: The rate at which the bore travels varies from ten to about thirteen miles per hour. The height of the bore rarely exceeds 12 or 14 feet; and broken water, in which no small boat could live, follows it for some distance. With the passing of the wave the tide rises many feet in a few seconds; in one instance, observed by Capt. Moore, it rose from 9 feet 4 inches below, to 4 feet 7 inches above, mean level. The rush of the bore was so strong that the force of the waves breaking against the broadside of the "Rambler" sent the water into the mizzen chains, and the spray on to

the poop. The junks in that region are protected by platforms with narrow steps cut in the sides. To the north of the estuary is a great sea-wall, built to protect the surrounding country from being flooded by these great tidal waves. It is thirty-five miles long, and it is strengthened, where the bore strikes most strongly, by an elliptical stone buttress, 253 feet long by 63 feet wide. Behind this the junks are drawn up for shelter.

—A test-piece of Mullens silicated iron, has stood a compression of 120,000 pounds per square inch. It finally broke in the same manner as specimens of stone do. It contained a very large proportion of silica.

—The latest news from the Sudan encourages the hope that Emin Pacha has successfully resisted the Mahdi, and makes it probable that Osman Digma's report of his surrender was solely a trick to prevent the English from action at Suakim. A despatch dated from Cairo, March 23, says that Mahommed Beraivi, who has arrived here from Omdurman, reports that Sheik Senoussi's forces occupied Darfur and Kordofan, and expelled the dervishes. In July last, Mahommed Beraivi accompanied an expedition of six thousand Mahdists which proceeded in steamers and barges against Emin Pacha. He states that Emin defeated the dervishes near Bor, killing most of them, and capturing their steamers and much ammunition. A despatch of the following day adds that Emin was reported to be in good health, and that all his people and some European travellers were with him in Bahr-el-Gazal.

BOOK-REVIEWS.

Profit Sharing between Employer and Employee. By NICHOLAS P. GILMAN. Boston and New York, Houghton, Mifflin, & Co. 12°. \$1.75.

THIS is an elaborate history of profit-sharing, beginning with the initiation of the system in France by Leclair, and tracing its development in Europe and America to the present time. The author shows a deep interest in his subject, and gives evidence of painstaking industry in the study of the facts. His work is well written and well arranged, and presents as exhaustive an account of the subject as any reader will be likely to want. Though Mr. Gilman is a firm and even enthusiastic believer in profit-sharing as a cure for the industrial evils of the age, he does not fail to recount those experiments with the system that have failed, as well as those that have succeeded. He does not confine himself however, to the mere history of the system, but discusses its value and its relations to the present wages system on the one hand, and to that of co-operation on the other. Co-operation, he thinks, is not destined to succeed, except under specially favorable circumstances, because the laborers are not willing to pay a sufficient salary to their manager to secure the best talent. Profit-sharing, on the other hand, leaves the management where it is now, while it furnishes the means, as Mr. Gilman thinks, to reconcile the laborers to their position. How far these views are correct, time alone can tell; but we would point out that the *Maison Leclair*, which the author chiefly relies on as an example of profit-sharing and its benefits, is really a co-operative society, somewhat different from the ordinary type, but none the less really co-operative. The workmen, or a certain portion of them, own one-half the capital, the two managing partners owning the remainder; and when one of the managing partners dies, or retires from the firm, the workmen who are shareholders choose his successor. Part of the profits are divided among all the workmen, whether they own capital or not; but this is only one of the distinguishing features of the *Maison*, that of co-operation being quite as prominent. We shall be glad to hear that Mr. Gilman's work meets with a ready sale.

Deductive Logic. By ST. GEORGE STOCK. London and New York, Longmans, Green, & Co. 16°. \$1.25.

THIS is an ordinary treatise on formal logic, with no considerable deviations from the usual type. The author says that before publishing the work he submitted it to the criticism of a friend, who advised him to strike out some new matter which the manuscript contained, and that he did so, retaining only a few novelties. Those

that are retained do not seem to us of any particular value, while one of them is of doubtful expediency: we mean his use of the term "privative attribute." This term has always been used to mean the absence of an attribute where it was once present or might be expected to be present; but Mr. Stock uses it to mean the absence of an attribute in a thing that might have it, as when a dish is called "empty." The execution of the work is in the main good; the style of expression, in particular, being very clear. The least satisfactory part in this respect is that relating to the syllogism, which, as in most other logical works, contains too much technical matter, and does not present a sufficient number of concrete examples to illustrate the principles. But while Mr. Stock's mastery of the forms of reasoning is complete, he has some views as to its nature and validity which can hardly pass unchallenged. Thus, he says that "inductive inferences are either wholly instinctive, and so unsusceptible of logical vindication, or else they may be exhibited under the form of deductive inferences (p. 128). And again he affirms that "no inductive inference can ever attain more than a high degree of probability; whereas a deductive inference is certain, but its certainty is purely hypothetical (p. 130). If this is true, the human intellect is in a bad way. Hence, without meaning to detract from the merits of Mr. Stock's work, we would suggest that what the world needs at the present time is not a new presentation of the forms of reasoning, but a deeper study of the nature of reasoning and of the principles on which it depends.

Botany for Academies and Colleges. By ANNIE CHAMBERS-KETCHUM, A.M. Philadelphia, Lippincott. 12°. \$1.

THE course of study in these lessons is based upon the inductive method of A. L. de Jussieu. Beginning with cryptogamia, plant-development is gradually unfolded, from the green stain on the door-stone to magnolia and clematis. Although the natural system is followed by the author, there are some departures from the method of Jussieu, its founder. This is recognized by the author, who, however, expresses the opinion that if Jussieu had lived to learn the lessons of the fossils, as well as other late discoveries in science, he would have been the first to advocate an arrangement which is so logical because it is so natural.

In addition to structural botany, which includes morphology, physiology, phytotomy or plant anatomy, and chemistry, systematic botany is concisely dealt with. The rules for nomenclature and pronunciation are especially deserving of mention. A manual of plants, including all the known orders with their representative genera, forms the second part of the volume. It is, of course, merely an outline of the 150,000 or more known species of plants, but it appears to be very complete. An excellent index and well-executed illustrations render this book one of the best for teaching purposes which we have seen.

A History of Eighteenth Century Literature. By EDMUND GOSSE. London and New York, Macmillan. 12°. \$1.75.

THIS is the third volume of the history of English literature which the publishers are now issuing, the second volume of which was noticed in *Science* when it appeared. The different volumes are by different writers, each chosen for his special acquaintance with the period to be dealt with, and the first and fourth volumes are not yet published. The present work covers the period from 1660 to 1780, — a period, as the author remarks, not exactly contemporaneous with the eighteenth century, but nevertheless forming a distinct chronological division in the history of English literature. The work is in the main well done, though it cannot be said to have any special charm of style. Its principal defect, according to our thinking, is the disproportionate attention it gives to insignificant writers, many pages being devoted to an account of works that are never read now except by a very small number of literary specialists. Mr. Gosse justly remarks that the principal work of the period under review was "to reform and regulate ordinary writing." The prose of the preceding age had been involved and clumsy to an extraordinary degree, and it was during the latter part of the seventeenth century that Englishmen first began to write in a style similar to that of the present day; while some of the writers of the eighteenth century have hardly been surpassed since. Another

notable work of the eighteenth century itself was the creation of the novel; and Mr. Gosse gives careful attention to both these literary developments. The principal figures in the literature of the period are, in Mr. Gosse's opinion, Dryden, Swift, and Johnson, though it would seem that Richardson, as the inventor of the novel, was entitled to equal rank. The greatest master of prose-style, Mr. Gosse thinks, was the metaphysician Berkeley. It must be understood, however, that the book does not deal with philosophical and scientific writers except with reference to their style. In his last chapter the author considers the relation of the English literature of the period to that of the Continent, — a subject that we should have been glad to see more largely treated.

Insects Injurious to Fruits. By WILLIAM SAUNDERS, F.R.S.C. 2d ed. Philadelphia, Lippincott. 12°. \$2.

THE first edition of this book appeared in 1883. The experience of Mr. Saunders as director of the Experimental Farms of the Dominion of Canada, and as editor of the *Canadian Entomologist*, would lead us to expect a valuable contribution from his pen. In this expectation we are not disappointed. The matter of the original edition was as complete as it could well be made. Since it appeared, additional facts have come to light, and in the second edition we have these facts embodied. For those who are not familiar with this admirable treatise, we will give a brief outline of its plan and contents.

The cultivation of fruit in America has now become such a matter of importance that every one, whether grower or consumer, is interested in the discovery of every thing which hinders or promotes this great industry. One of the most important factors is insect-life. Injurious insects are so universally distributed that there is no part of this continent where fruit-culture can be profitably carried on without some effort being made to subdue them. But all insects are not injurious. There are friendly species as well as those that are inimical. Indeed, it is to these friendly ones that nature has assigned the task of keeping in subjection those that are destructive, by devouring either their bodies or their eggs. Thus it becomes a matter of great importance that the fruit-grower should be able to distinguish between friend and foe, lest, in his efforts to destroy the latter, he may be depriving himself of his strongest ally. Until Mr. Saunders took this subject in hand, the fruit-grower was obliged to search for much of his information in State and departmental reports, or in books on scientific entomology. In these volumes the practical knowledge is so much encumbered with scientific and other details as to make the acquisition of it too laborious a process for those whose time is so fully occupied as is that of the practical fruit-grower. In the book before us the author has endeavored to bring together all the important facts relating to insects known to be injurious to fruits in all parts of Canada and the United States. His experience as a fruit-grower and student of entomology for nearly thirty years has enabled him to succeed in his self-appointed task, and to present the results in a concise manner, and as free from scientific phraseology as is possible. In the arrangement of the subject, the author has adopted the plan of grouping together the insects injurious to a particular tree or plant. Thus, under the heading, "Insects Injurious to the Apple," we find all the known species inimical to this fruit-tree. These main headings are still further subdivided into those which treat of the insects which attack the roots of the apple-tree, those which attack the trunk, the branches, the leaves, and the fruit. Each of these is fully illustrated, so that the determination of any injurious species is rendered comparatively easy. The species having been identified, the methods to be adopted for its destruction are described. The plan is not only an admirable one from a theoretical point of view, but that it is also a practical one, and one which meets the wants of those interested, is demonstrated by the demand for a second edition. Not less worthy of commendation is the execution of the work. An author's best efforts are often rendered nugatory by the parsimony of his publisher, who is unwilling to provide the necessary illustrations or such paper and type as will make the book attractive. In this respect there can no fault be found by Mr. Saunders. The execution of the work is excellent in all respects, making its perusal a pleasant as well as a profitable task.

SCIENCE:

A WEEKLY NEWSPAPER OF ALL THE ARTS AND SCIENCES.

PUBLISHED BY

N. D. C. HODGES,

47 LAFAYETTE PLACE, NEW YORK.

SUBSCRIPTIONS.—United States and Canada.....\$3.50 a year.
Great Britain and Europe.....4.50 a year.
Science Club-rates for the United States and Canada (in one remittance):

1	subscription	1 year.....	8 3.50
2	"	1 year.....	6.00
3	"	1 year.....	8.00
4	"	1 year.....	10.00

Communications will be welcomed from any quarter. Rejected manuscripts will be returned to the authors only when the requisite amount of postage accompanies the manuscript. Whatever is intended for insertion must be authenticated by the name and address of the writer; not necessarily for publication, but as a guaranty of good faith. We do not hold ourselves responsible for any view or opinions expressed in the communications of our correspondents.

VOL. XIII. NEW YORK, MARCH 29, 1889. No. 321.

CONTENTS:

THE SUBMERGING MONITOR CRUISER	229	BOOK-REVIEWS.	
TOBIN BRONZE.....	230	Profit Sharing between Employer and Employee.....	238
A LARGE ELECTRIC-CURRENT CONDUCTOR.....	230	Deductive Logic.....	238
A METEOROLOGICAL EXHIBITION.....	230	Botany for Academies and Colleges.....	239
THE HORNING DIRECT-POWER STEERING SYSTEM.....	231	A History of Eighteenth Century Literature.....	239
PLATINUM.....	232	Insects Injurious to Fruits.....	239
THE HISTORY OF PORPHYRITIC QUARTZ IN ERUPTIVE ROCKS.....	232	EDITORIAL.....	240
ETHNOLOGY.		The Treatment of Insane Criminals in New York.—New Projects for Polar Explorations.....	
The Man of Spy.....	232	THE WOMEN'S ANTHROPOLOGICAL SOCIETY OF AMERICA	
Beans cultivated in Prehistoric Arizona.....	233	Mrs. Anita Newcomb McGee	240
ELECTRICAL NEWS.		THE "EXCELSIOR CLASSES" IN AUSTRALIA.....	242
Electrical Lines of Force.....	234	AMONG THE PUBLISHERS.....	243
Arc-Lamp for Incandescent Circuits.....	235	LETTERS TO THE EDITOR.	
Dynamo-Designing.....	235	The Soaring of Birds.....	
The Magnetic Action of Displacement Currents in a Dielectric.....	235	Definition of Manual Training.....	245
Patents on Alternating-Current Transformers.....	235	Curves of Literary Style.....	246
The Tesla Alternating-Current Electric Motor.....	235	The Velocity of Storms as related to the Velocity of the General Atmospheric Movements.....	246
The Birmingham Electric Locomotive.....	235	The Robinson Anemometer Factor.....	248
The Dimensions of Electrical Units.....	236		
A New Dynamo.....	236		
NOTES AND NEWS.....	236		

THE PRACTICE which has existed in the State of New York since 1864 of confining insane persons charged with crime at the Auburn State Asylum for Insane Criminals has seemed to many to be in need of revision. Senator Pierce has introduced into the Legislature a bill to discontinue the practice. In addition to this measure, others affecting the lunacy laws are before the Legislature for its consideration. One of these provides for the appointment of six commissioners to revise all the laws of the State relating to lunacy; another, if passed, will substitute a commission for the one existing commissioner; still another measure provides for the care of the dependent insane in State rather than, as is now the practice, in county institutions. This latter bill seems to us to be by far the most important of all those which have been introduced during the present year. Under this law the State will be divided into districts by a board, to be constituted of the president of the State Board of Charities, the State commissioner in lunacy, and the State comptroller. After this board shall have established the insane districts, they are to file with the secretary of state the boundaries of the same, and the number of pauper insane people within each. In each of these districts suitable buildings and accommodations are required to be erected, either on new sites or on the site of some asylum already in existence. To these asylums, indigent and pauper insane are required to be sent for maintenance, instead of

being retained in county asylums. There are sixty counties in the State, and as many insane-asylums. Under the proposed law, this number would be reduced to ten. It would be possible to establish a uniform system of treatment in institutions managed by a State board, which it would be next to impossible to effect under the county system. The proposed plan would put a stop to the abuses which are believed to exist in some of the present institutions, and is, for this and many other reasons, supported by the medical profession and laymen who are familiar with the disadvantages of the present system.

RECENTLY SOME NEW PROJECTS of polar explorations have been made. Since the failure of the British Government to support the scheme of the Australian colonies, little has been done regarding the proposed Antarctic expedition. At present, according to the *Journal of the Royal Geographical Society*, a scheme is on foot for the furtherance of Antarctic exploration by private enterprise. A New Zealand colonist (a Norwegian) has gone to Europe for the purpose of taking out with him a number of Norwegians who have been accustomed to fishing. In one or two steamers, the gentleman referred to intends to send out these Norwegians, under proper command, accompanied by one or more scientific men, with suitable equipment, for the purpose of exploring the Antarctic region, with the ultimate object of establishing a whale-fishery on an extensive scale. If at all practicable, a party will be left during a whole year on Victoria Land, or other suitable place, in order that the conditions of the region may be thoroughly investigated.

On the other hand, various plans of continuing Arctic researches are on foot. It is stated that a movement has been started in Norway for the despatch, in the summer of 1890, of an expedition which will try to reach the north pole; and it is proposed to offer the leadership to Dr. Nansen, who will probably return from Greenland in a few weeks. The intention is that an attempt should be made to reach the pole by way of Franz-Josef Land, — a route which is advocated by some of the most competent authorities on Arctic explorations. *Shi*, which have played so prominent a part in the Nordenskiöld and Nansen Greenland expeditions, would no doubt again prove of service. The Geographical Society of Bremen is about to send out an exploring expedition to the Spitzbergen Sea, the main object being inquiries into the zoölogy of this region. The scientists of this expedition will be Dr. W. Kükenthal, the well-known zoölogist, and Dr. A. Walter. The party will start from northern Norway.

THE WOMEN'S ANTHROPOLOGICAL SOCIETY OF AMERICA.¹

ON June 8, 1885, ten intellectual women of Washington met to form a scientific society. The idea was a novel one and hazardous, in that only one of the participants had ever done scientific work; to wit, Mrs. Tilly E. Stevenson. In her mind the plan of a woman's anthropological society was conceived; and to her energy, ability, and fostering care are due its birth and larger growth.

At the time of organization the objects of the society were stated to be, "first, to open to women new fields for systematic investigation; second, to invite their co-operation in the development of the science of anthropology." The present constitution declares that "the object of this society shall be to promote anthropology by encouraging its study and facilitating the interchange of thought among those interested in anthropologic research, and by arranging and preserving systematically all information relating to it, and also by holding regular meetings for its discussion."

It is often asked why there should be two anthropological societies in Washington. Speaking for ourselves, we have no desire to

¹ General report of the recording secretary, Mrs. Anita Newcomb McGee, read before the society at Washington, D.C., Feb. 25, 1889.

perpetuate a distinction of sex in science; and were we all professional scientists, or possessed of education fitting us to enter the race for intellectual attainment without handicap, we doubt whether a second society would ever have been formed. Under existing conditions, however, we are satisfied to work out our own problems in anticipation of the time when science shall regard only the work, not the worker.

The society has managed its business, held its regular meetings, and listened to the papers of its members, for nearly four years, and, in spite of prophecies to the contrary, has slowly but steadily grown, — all without a single unfriendly disagreement or any pre-erogation of dissolution.

Much of the credit for this success and harmony is due to Mrs. Stevenson, the founder, and for three years and a half the president, of the society. Her principal supporter at first was Miss Sarah A. Scull, then teacher of ancient history and mythology in Mrs. Somers' school for girls, and the society's corresponding secretary. The other officers selected at the preliminary June meeting were Mrs. Emma Louise Hitchcock for recording secretary, and Mrs. Mary Parke Foster for treasurer. A constitution was drafted and adopted at the same meeting, and the society then adjourned until Nov. 28, 1885. By-laws were proposed on Dec. 12 of the same year. At the first annual meeting, held Jan. 30, 1886, the constitution and by-laws were amended, and additions were made to the board of trustees in accordance with the code. These were the two vice-presidents, Mrs. Mary E. James and Mrs. Lida Nordhoff, and six trustees, — Miss Alice C. Fletcher, Mrs. Jean M. Lander, Mrs. Emma Hammond Ward, Mrs. Mary Olmsted Clarke, Dr. Clara Bliss Hinds, and Mrs. Cornelia E. McDonald.

Other names which appear later on the board are Mrs. Sybil Augusta Carter and Mrs. Eliza Blair, as vice-presidents; Mrs. Blair, having previously filled the office of corresponding secretary, succeeding Miss Scull when the latter departed this country for Greece, in May, 1886. At the same time the recording secretary, Mrs. Hitchcock, temporarily left the young society, and journeyed toward Japan, where she observed the ever-interesting Orient for our future benefit. An able and worthy successor to the secretaryship was found, however, in the person of Mrs. Mary Olmsted Clarke. Mrs. Melissa A. Bryan, Mrs. Miranda Tullock, and Miss Florence P. Spofford have more recently served as trustees of the society. At the close of 1886 it was found necessary to subject the original and temporary constitution and by-laws to a thorough revision, and this task was accomplished so well that no alterations have since been made.

The members of the Women's Anthropological Society of America are grouped in three classes, — honorary, corresponding, and active. The last includes a sub-class of absent members, who are temporarily inactive. As originally organized, the society contained one honorary member, — Miss Rose Elizabeth Cleveland, — and twenty-one active members, of whom five were not residents of Washington. The policy of the society has always been to maintain a high standard of membership, one result of which is a practical limitation in numbers. The formalities surrounding the admission of new members are such that about a month elapses before a proposed name can be finally enrolled. At the same time, any thinking, intelligent woman likely to take practical interest in the work is gladly welcomed to the society.

The membership to-day includes three honorary, eleven corresponding, and forty-six active members. Seven among the last are upon the absent roll.

Regular meetings are held on Saturday afternoons of each alternate week from November until May inclusive. The fiftieth of these will be held on Saturday of this week. The average attendance has varied in different years from eleven to fifteen. For over two years the society has been greatly indebted to the president and trustees of Columbian university for the use of the reception-rooms of the university building for our bi-weekly meetings. The regular meetings are devoted primarily to the presentation and discussion of original scientific communications; and all business, except elections, is transacted in detail at meetings of the board or in committee before being submitted to the general society.

In addition to the regular meetings, the by-laws provide for spe-

cial meetings, and an annual meeting in January for the election of officers and trustees and the reading of reports. An annual reception may also be given, at which the retiring president is expected to deliver an address. In 1887 this reception was omitted, owing to the illness of the president. This is the only occasion on which refreshments are permitted by the code.

The year 1889 has seen many changes in the board of trustees. As constituted at present, it is as follows: president, Mrs. Sybil Augusta Carter; vice-presidents, Mrs. Mary Parke Foster and Miss Alice C. Fletcher; recording secretary, Mrs. Anita Newcomb McGee; corresponding secretary, Mrs. Emma Hammond Ward; treasurer, Miss Florence P. Spofford; members at large, Mrs. Mary Olmsted Clarke, Mrs. Jean M. Lander, Mrs. Marianna P. Seaman, Miss Lydia M. Dame, and Mrs. Hannah L. Bartlett, with a vacancy to be filled at the next meeting.

One of the first movements of the new board has been toward the formation of a library. A number of important works have been presented to the society, and through the courtesy of Major J. W. Powell these are about to be placed in the library of the Bureau of Ethnology. Donations of anthropologic works will be gratefully received by the librarian, Mrs. Marianna P. Seaman.

Were we dependent upon what the society had published, our library could be easily read. With the caution and forethought characteristic of our founder and her associates, the youthful body has refrained from much printing. Four small pamphlets have, however, appeared. "The Organization and the Constitution of the Women's Anthropological Society" (1885) was superseded in 1887 by the revised "Constitution, By-Laws, and List of Members." The two other pamphlets were designed to direct the members in their work. "Child-Growth," by Dr. Clara Bliss Hinds (1886), was a plea for, and directions concerning, anthropometry. "What is Anthropology?" by Professor Otis T. Mason (1888), was printed by the society as the best available classification of anthropologic science, and at the same time as a guide to the branches of the subject requiring investigation.

It is now hoped that a volume of proceedings may be published at no distant day, though the material for it is considerably diminished by the publication elsewhere of several valuable contributions. As a general rule, a single paper, nominally thirty minutes in length, is read and discussed at each meeting. Forty-three communications have thus far been contributed by members, a number of which were presented orally, and two presidential addresses have been delivered. In addition, two lectures were delivered at special meetings in 1887, — the first on Feb. 12, by Mr. A. R. Wallace, on "The Great Problems of Anthropology;" and the second on April 23, by Mr. J. H. Smyth, on "The African in his Home and in America."

In reviewing the work of the society, it is noticeable that the majority of the papers represent the results of personal observation on the part of their authors. They are real contributions to knowledge, generally much condensed from abundant material collected on some given subject.

It results from this custom that no discussion has ever been given to the origin, antiquity, or primitive condition of man, and no studies have been made in race-classification or in philology.

A large number of papers are ethnographic in character, as were the two presidential addresses of Mrs. Stevenson, — "The Religious Life of the Zuñi Child," delivered in 1886, and published in the "Fifth Annual Report of the Bureau of Ethnology;" and "The Thirteen Medicine Orders of the Zuñi," delivered in 1888, and printed in abstract in *Science*. Four other papers presented by Mrs. Stevenson either have appeared or are to appear among the publications of the Bureau of Ethnology. Their subjects are, 1st, "The Moki Indian Snake-Dance;" 2d, "Mission Indians," in which are described the cosmogony, the ceremony of purification upon arriving at puberty, and the baptismal ceremony of the San Luisiño Indians of southern California; 3d, "The Sand-Paintings of the Navajos;" and, 4th, "Zuñi and the Zuñians." Some of these papers were illustrated by original drawings. Of similar character are the four papers from Miss Alice C. Fletcher, an original member of the society, who needs no introduction to the students of anthropology here or abroad. The first of these, "Omaha Child-Life," appeared in part in the *Journal of American Folk-*

Lore. The second, entitled "The Supernatural among the Omaha Tribe of Indians," was afterwards published in Vol. I. No. 3, of the "Proceedings of the American Society of Psychical Research." The third paper was on "Winter Life among the Winnebago Indians;" and the fourth, on "The Heathuska Society of the Omaha and Ponka Indians and Indian Music." The last is now in press as a publication of the Peabody Museum of the American Archaeology. Commendation of the original and important work of Mrs. Stevenson and Miss Fletcher would be quite superfluous.

"Legends and Historical Sketches of the Iroquois Indians" (Washington, 1887) is the title of a privately printed pamphlet by Mrs. Laura M. Scofield, containing material previously presented to the society in two papers. Two valuable communications have been given orally by corresponding members; viz., "Reminiscences of Life among the Iroquois Indians in the Province of Quebec," by the late Mrs. Erminnie A. Smith; and "The Sioux Indians," by Miss Mary C. Collins of Dakota.

A number of members at one time found a most interesting field for study in the Basque races, and their results were presented in a series of brief papers. Mrs. Seaman discussed the home life of the Basques; Mrs. Carter and Mrs. Tullock, their literature; Mrs. McDonald described their marriage customs; and Miss Spofford, their music. Miss Cathcart also condensed the results of prolonged study into an account of the spread of the Turanian races into Europe.

These papers on the Basques are all compilations, but personal observation is again represented in such communications as the following: Mrs. Carter, our esteemed president, has given an admirable account of the Hawaiians, while Mrs. Jean M. Lander ably described some customs and manners of Scotch Highlanders. Mrs. Melissa A. Bryan offered some notes upon the Japanese; Mrs. Louise F. Hunt talked about Russia; and Miss Elisa R. Scidmore has quite recently presented a chapter from her forthcoming work on Korea.

The division of technology is represented by several papers, three of them being especially noteworthy and interesting. Under the title "Habitations of Man," Mrs. Hannah L. Bartlett summarized her researches concerning the dwellings of a large number of civilized people. An account of house-building in Alaska came from Mrs. Ella F. Thomas, as one result of a two-years' stay in that land. To these Mrs. Carter added some facts concerning the habitations of the Hawaiians. Mrs. Matilda G. Bancroft of San Francisco acknowledged her membership in our society by sending a paper on "Ceramic Art of the Pacific Coast;" and Mrs. Mary E. Brown of New York, a corresponding member, read what has since appeared as the chapter on "Chinese Music," in her book entitled "Musical Instruments and their Homes" (New York, 1888). Another interesting and important contribution, from Mrs. Scofield, is on "Petroleum and Natural Gas and their Relations to Man."

Only two papers may be classed as archæologic. The departure of Miss Sarah A. Scull for Greece in the spring of 1886 has already been mentioned. Her destination was Athens, where for over two years she was connected with the American School of Classical Studies, and pursued original researches among the ruins of Hellas. Her work and that of her associates was the theme of a most interesting discourse with which the society was lately favored.

An account has been given of studies in a similar direction, though not so detailed in character. The communication of Mrs. Mary Parke Foster on "The Ancient Ruins of Mexico" was based on material collected during a seven-years' residence in our neighboring republic. During this time some expeditions into almost unknown territory were made, and certain ruins explored for the first time by a foreign lady.

In the division of sociology appears a recent account of the evolution of a community. In this Mrs. McGee followed the development of a religious body from its origin in Germany through various stages to its present state as the most successful communistic organization in America. Two years ago the study of folk-lore was commended by Miss Ellen Wier Cathcart, and Mrs. Mary Olmsted Clarke gave some negro song games which had not been discovered by either Mr. W. H. Babcock or Professor H. C. Bolton.

Last, but not least, must be mentioned the papers in somatology, some of which have also touched on psychology. Mrs. Clara Bliss Hinds, M.D., has long made a special study of anthropometry, and has urged upon our members the value of proper measurements and records in her paper already noted on "Child-Growth" and in "How to Study Children." Mrs. Mary E. James presented an able *résumé* of studies made in the asylums of Brooklyn, N.Y., in her communication on "Food in its Relations to Child-Growth." Under the title "Comparative Human Growth," Mrs. Emma Hammond Ward set forth some important but little known physiologic laws and their mental and moral bearing upon the race. Here, too, must be included Mrs. Scofield's paper upon "Life." Finally, the president of the Washington branch in the Association of Collegiate Alumneæ, Mrs. Anna Howes Barus, has treated us to "The Physical History of College Women," an article based on statistics collected under the direction of its author, and already published elsewhere.

Such are the principal themes thus far discussed by our society. In these brief notes it has been impossible to convey more than the vaguest idea of their scope or character, or to indicate their value as original contributions to knowledge. The purpose of this report will have been served if some conception has been given to this new work undertaken by women, and of the progress already made upon it. Mistakes have been made in the management and work of the society. We do not claim perfection in any particular, but we do believe our organization to be the minute seed from which a great forest will spring.

There are hundreds of societies in which knowledge is cultivated and fostered for its own sake, and in which many grand and useful conceptions find birth; there are in the United States several scientific societies devoted wholly to anthropology; but among all of these the first to be organized and maintained by women alone is the Women's Anthropological Society of America.

THE "EXCELSIOR CLASSES" IN AUSTRALIA.¹

ABOUT five or six years ago, Mr. William Groom, a young workman in a silk-hat factory in Melbourne, used to observe with great distaste the large number of boys who were drinking in the saloons of the city, especially on Saturday nights. The sight at last troubled him so much, that he resolved to attempt some method of diminishing the evil; so one evening he accosted a group of boys in a saloon, and asked them whether they really found any enjoyment in that mode of spending time. They answered that perhaps, after all, there was not much fun in it. Mr. Groom then invited them to come next Saturday evening to his lodgings, and said that he would try to furnish them with better amusement. Some of the boys came; and Mr. Groom, though feeling awkward and embarrassed, did his best to entertain them with games, reading, and a little personal talk. By degrees his unique power of influencing boys became manifest; numbers began to gather round him; and his work became known to few persons of wealth and position, who, recognizing Mr. Groom's peculiar gifts, agreed to guarantee a sufficient sum annually to enable him to devote his whole time to the work among the boys.

It may be mentioned, in passing, that Mr. Groom's most enthusiastic supporter is a young artist, belonging to a family of high standing and influence in Victoria, who is himself carrying on an interesting and valuable work in the Melbourne Hospital. Owing to impaired vision, he is able to work at his profession only during the morning hours; he therefore devotes three afternoons in the week to visiting the patients in the surgical wards of the hospital, — those in the medical wards having comparatively little superfluous energy, — reading and talking to them, keeping them supplied with books, and teaching them netting, macramé-work, and the construction of picture-frames and a variety of other artistic and useful objects. The various materials required he brings at each visit. In this way the wearisome hours of the patients are lightened, some useful minor industries are learned, and the sale of the products gives the patients in many cases a substantial sum of money to make a fresh start when they are discharged from the hospital.

¹ Notes of a talk by William Grey, Esq., of the Denison Club, London, to a few students of social science in the Johns Hopkins University, Jan. 22, 1889.

To return to Mr. Groom's special work. When he was enabled to give his whole time to it, the movement spread rapidly. Six or seven large classes, each consisting of several hundreds of boys, were formed in various parts of the city. Mr. Groom's earnest endeavor throughout was to establish them on a self-governing and self-supporting basis, and to avoid all showy display of the work for the sake of obtaining "patronage" and contributions. The weekly meetings of the classes are held primarily for the sake of mutual entertainment. A large room is either lent or rented, and a varied performance takes place,—songs, recitations, an occasional farce, and a few words of advice, admonition, or encouragement from the leader of the class. The chairman of the meeting is elected by the boys, as also are the secretary, treasurer, and door-keepers. Mr. Groom, when he is present, is always elected as leader. The small dues of the class, usually about six cents, are collected weekly. In connection with the classes, too, are penny banks and lending libraries. A remarkable work has been carried on by some of the bigger boys, who were formerly leaders in mischief and outrage among the vicious "larrikins" who nightly haunt the streets of the Australian cities, and cause sore perplexity to those who study social problems in those colonies. A few of these reclaimed "hoodlums," sally forth together on Saturday nights, go from one saloon to another, and, if they see boys drinking there, bid them come out and join them. The boys instinctively obey their former leaders, meekly follow them, and are brought within the circle of influence of the Excelsior Classes.

From Melbourne the movement has already spread to Sydney. A young clerk in one of the government offices of New South Wales, while on a visit to Melbourne, heard of Mr. Groom's work, and was so deeply impressed by what he saw of it that he determined to devote his evenings to a similar work in his own city. An admirable class is now organized in the midst of a very poor district.

It was at Sydney that I first came into contact with the work. I well remember the striking character of the scene. Passing between two vigilant boy door-keepers, I entered a large, bare school-room, lighted with flaming gas-jets. More than a hundred boys of all sorts and sizes, many ragged and with bare feet, were sitting, absolutely quiet and orderly, with eager, intelligent faces, listening to a few words from their elected leader or "critic," as he is here styled, the government clerk whom I have mentioned. The chairman, secretary, and treasurer, each adorned with a broad crimson scarf, as of some knightly order, were at their posts. Then the entertainment began, consisting almost entirely of recitations and songs chosen by the boys themselves. No trace of any thing coarse or low appeared: the tendency, oddly enough, was to pieces of a profoundly melancholy and sentimental order. The choruses of the more lively songs were taken up by the whole body of boys with an energy which seemed almost great enough to break the windows and blow off the roof. But throughout the meeting the order and discipline maintained for themselves by these rough street boys was simply perfect. After the entertainment was over, the treasurer collected the weekly dues, and then the business of a penny bank was transacted. I left the meeting, feeling that I had seen the finest sight in all Australia.

Some weeks later I had the privilege of meeting Mr. Groom himself at his little house near Melbourne. At this time he was in a very shattered state of health, and only just recovering from the effects of a terrible railroad accident. He had been compelled for six months to withdraw entirely from the supervision of the Excelsior Classes; but he was still able to attend to a deeply interesting branch of his work at home,—the rescue of boys of the most depraved and degraded class, whom he had found lying about the wharves at night, or had intercepted on their discharge from prison.

He showed me in his back garden a low, long barrack of six little chambers, separated from each other by solid walls, so that no communication should be possible by night among the inmates. Each room was simply but prettily furnished. On the wall hung an illuminated and framed copy of the Lord's Prayer; and in another frame, a stanza of some hymn or poem, intended to meet the special need of the occupant of the room. During the day the boys are sent to the public school: the rest of their time is filled up

with work of various kinds,—carpentry, digging, gardening, and household duties. They take their meals with Mr. and Mrs. Groom, and thus learn decent manners at table. Mr. Groom has gone with great care and thoroughness into the subject of the various forms of vice to which these poor boys are specially prone, and uses every effort to ascertain and apply the surest and most appropriate remedies and preventives. When the boys have been thoroughly reclaimed, they are drafted off to places in the country. The demand for the boys is far greater than Mr. Groom can supply.

This is a department of his work which Mr. Groom guards with the greatest care from ostentatious publicity, rightly deeming that the subject is far too grave and awful to be made a matter of advertising and promiscuous patronage. The necessary funds are, I believe, supplied by a few attached friends, and by a single large business firm. It is by no means easy—*experto credite*—for others to obtain the privilege of contributing to the work.

It was exceedingly interesting to observe the effect upon the Excelsior Classes of Mr. Groom's disablement. Four or five of the classes, it must be confessed, had at the time of my visit lapsed into a state of suspended animation, although there was every reason to hope that they would revive at Mr. Groom's touch. One class which I visited was still in operation, but it was evidently on the point of breaking down. The temporary leader, a good and really heroic young fellow, was evidently not quite fitted for his post. On the evening of my visit the meeting was a very large one, and a number of turbulent youths had made their way in. The leader, as I could tell from my former scholastic experience, was at fault in every appeal which he made to the audience, and naturally excited some derision. However, the performance was creditably gone through, in spite of some interruptions. I was struck by the genuine courtesy of the boys, who, although I was the only visitor present in the unruly assembly, never by word or act made my position in the slightest degree uncomfortable, although considerable ingenuity was shown in worrying their "leader." I was not surprised to learn that the subsequent meeting broke up in confusion, and the class was suspended.

In the next class which I visited, all was cheering and hopeful. About a hundred boys, with many of their friends and relations, were present in a cheerful, well-lighted schoolroom. An admirable entertainment was provided,—songs, recitations, a short farce, and, if I remember rightly, some gymnastic exercises. A few wholesome words were addressed to the boys by their elected leader,—a young, fresh-looking boy, who is employed as a clerk in a business-house. Although the class had for six months been deprived of Mr. Groom's supervision, the order and discipline of the meeting left nothing to be desired. The genial *bonhomie* and courtesy of the boys deeply impressed me. I remained for some time after the meeting, talking with the boys, and examining their library and savings bank. My favorable impression was continually deepened. Here, I thought, was a sight even grander than I had witnessed in Sydney, as proving what democratic government, free from all suspicion of being qualified, may do among boys.

Some further details of this interesting work may be derived from *The Excelsior*,—a monthly paper which was, and not improbably is still, published for the classes. Mr. Groom himself is always pleased to communicate with persons who are genuinely and practically interested in this and similar work. Address W. Groom, care of Edw. à Beckett, Brighton, Melbourne, Australia.

AMONG THE PUBLISHERS.

GINN & Co. have in preparation "Our World," by Mary L. Hall, revised and arranged as a supplementary reading-book.

—The latest issue of Ticknor's Paper Series is the novel "Under Green Apple Boughs," by Helen Campbell. The story is illuminated by eight full-page pictures by Howard Pyle.

—The *Fortnightly Review* for March (New York, Leonard Scott Publication Company) opens with the first of Sir Charles Dilke's important and valuable papers on "The Frontiers of India," in which he describes his journey, and the impressions made in the earlier part of it; F. I. Ricarde-Seaver and Sir Charles Metcalfe contribute a comprehensive article on "The British

Sphere of Influence in South Africa," illustrated with a map in colors; Professor Max Müller writes on "Some Lessons of Antiquity;" Mrs. Lynn Linton continues her series on "The Characteristics of English Women," and Mme. Blaze de Bury treats of "The Decadence of French Thought;" and J. D. Bouchier writes a timely paper on "The Heritage of the Hapsburgs." Other articles include "Australia in 1888," by the Earl of Carnarvon; "Obstruction and its Cure," by Sir G. Baden-Powell; and "The London Water-Supply," by Dr. Roose.

— A "History of West Virginia," from 1732 to the present time, has been written by Professor Virgil A. Lewis of Mason City, Mason County, W. Va. Only a limited number of copies will be published, and they will be sold by the author. "Professor Lewis," says the *Evening Post*, "has carefully examined all authentic rec-

ords of the State, the archives at Richmond, and those at county-seats, — in all, nearly one hundred. The first part of the book treats of the first permanent settlement in the Shenandoah valley, and comes down to the revolutionary war. Part second covers the ground between the Revolution and the civil war, and part third brings the narrative down to the present time."

— It is proposed to issue from time to time, in connection with the *Johns Hopkins University Studies in Historical and Political Science*, brief notes on current topics of interest. "Municipal Government in England," a report of an interview with Albert Shaw, Ph.D., was issued in January, 1889.

— *The Trained Nurse*, published from Buffalo, N. Y., suggests a new opening for professional nurses on board the large ocean-steamers, caring for seasick passengers.

Publications received at Editor's Office, March 4-23

ALEXANDER, W. J. An Introduction to the Poetry of Robert Browning. Boston, Ginn & Co. 212 p. 12^s. \$1.10.
 BERNHEIM, H. Suggestive Therapeutics: A Treatise on the Nature and Uses of Hypnotism. Tr. by C. A. Herter. New York and London, Putnam. 420 p. 8^s. \$3.50.
 BONAPARTE, R. La Nouvelle-Guinée. III. Notice le Fleuve Augusta; IV. Notice le Golfe Huon. Paris, The Author. 78 p. 8^s.
 BOWDITCH, H. P. Hints for Teachers of Physiology. (Guides for Science-Teaching, No. XIV.) Boston, Heath. 28 p. 24^s.
 GALTON, F. Natural Inheritance. London and New York, Macmillan. 250 p. 8^s. \$2.50.
 GILMAN, N. P. Profit Sharing between Employer and Employee. Boston and New York, Houghton, Mifflin, & Co. 460 p. 12^s. \$1.75.
 GREAT DIVIDE, THE. Vol. I. No. 1. m. Denver, Col., Great Divide Publ. Co. 72 p. 1^s. \$1 per year.
 GREENE, H. R. Greene's Language Half-Blanks. Graded Exercises in Analyzing and Diagraming, No. 1. The Sentence and its Four Principal Parts. New York, A. Lovell & Co. 43 p. 12^s.
 HARDY, A. S. Elements of Analytic Geometry. Boston, Ginn & Co. 229 p. 12^s. \$1.50.
 How to be Successful on the Road as a Commercial Traveller. By an old drummer. New York, Fowler & Wells Co. 33 p. 20 cents.

DRAGON'S TEETH.

Translated from the Portuguese by Mrs. MARY J. SERRANO. 12mo. \$1.50.

"Suggests the close detail, and even the nicety of touch, that distinguishes Daudet. It turns upon the tension and unfaithfulness of a weak but loving woman. The plot is what we have learned to look upon as peculiarly French, and it is treated with French simplicity and frankness, without coarseness. It is a terrible presentation of the sure results of immorality. The slow tribulation that follows the sin is remarkably depicted."—Nora Perry.

"A story of sin and its consequences powerfully set forth, and withal there is a great deal of humor in the story, a keen insight into the weaknesses of human nature that is delicious. It is wonderfully good. As a work of literary art, as a story, as a picture of life as it is lived under certain conditions, the book is a model."—Jeannette L. Gilder.

A Novel by the Author of "The Story of Margaret Kent."

A DAUGHTER OF EVE.

1 vol., 12mo, \$1.50.

"Exceptional cleverness, effective satire, a great deal of humor."—Boston Advertiser.

"A story that for rare merit and interest will surpass even either of this author's former novels that have won such a place in the literary world."—Home Journal.

"Graciously winning as was 'The Story of Margaret Kent,' brilliant and moving as was the tale of 'Queen Money,' we are strongly inclined to say, after reading 'A Daughter of Eve,' that the author has attained to a still more gratifying artistic triumph than in the case of either of the other two novels we have mentioned. Brilliance, sparkle and wit 'A Daughter of Eve' has in abundance, but it also has a definite ethical motive treated with inimitable taste."—Beacon.

Sold everywhere. Sent, postpaid, on receipt of price by the Publishers,

TICKNOR & CO., Boston.

STOCK, St. G. Deductive Logic. London and New York, Longmans, Green, & Co. 366 p. 16^s. \$1.25.
 THORPE, F. N. The Government of the People of the United States. Philadelphia, Eldredge & Brother. 308 p. 12^s. 90 cents.

A BOOK FOR THE TIMES!

NEW EDITIONS!

Laidlaw's Constitution of the United States and the Declaration of Independence, in English, French, and German, with notes. Sold by all booksellers, or by the publishers, LAIDLAW BROS. AND CO., 137 W. 41st St., New York.

Second and Revised Edition, in cloth ----- 50c. postpaid.
 Third Edition, in paper ----- 25c. postpaid.

The New Princeton Review

Having been merged into the Political Science Quarterly, a complete set of the New Princeton Review, eighteen numbers in all, is offered for \$2.50, regular price, \$9.00. Among the contributors are Bancroft, Lowell, Norton, Bryce, Tolstoy, Taine, Benjamin, Comte de Paris, Lathrop and Eggleston.

As the supply of complete sets is limited, those desiring to avail themselves of this low offer, should write at once to Ginn & Company, Publishers Political Science Quarterly, 743 Broadway, N. Y.

Just Published!

PRIMER OF SCIENTIFIC KNOWLEDGE.

Man, Animals, Plants, Stones, The Three States

of Bodies, Reading Lessons, Summaries,

Questions, Subjects for Composition.

BY PAUL BERT,

Author of "Bert's First Steps in Scientific Knowledge."

TRANSLATED AND ADAPTED FOR AMERICAN SCHOOLS.

Illustrated 12mo, cloth, 36 cents.

This new work is carried out in the same spirit as "First Steps in Scientific Knowledge," and follows the same plan. The book is so arranged that the larger work becomes a review and extension of the subject. The method, which consists in presenting to the child during two or three consecutive years the same subjects, in the same order, following the same general arrangement, but with an increasing number of facts and a progressive elevation of ideas, is an excellent one, and is now universally adopted.

The reductions have naturally been largely in Physics, Chemistry, and Vegetable and Animal Physiology. Yet, a somewhat fuller development has been given to the descriptive part of Natural History, and to applications easy to comprehend. These two works, then, depend upon each other. They form a coherent whole. The first prepares for the second, the second completes the first; at the same time each has its individuality, and can be used without the other.

In the present translation only such changes and additions have been made as were necessary to Americanize the book and adapt it to the requirements of public and private schools in this country.

The illustrations are for the most part entirely new. Those upon Natural History were drawn from life by some of our best artists.

Sent post-paid on receipt of price.

J. B. LIPPINCOTT COMPANY,

715, 717 Market Street, Philadelphia.

—The poem by Oliver Wendell Holmes, in honor of the dinner given by Russell Lowell on his seventieth birthday, is the first thing to which the readers of the April *Atlantic* will turn. Mr. H. C. Merwin contributes a paper on "The People in Government;" and Mr. Samuel Sheldon answers the question "Why our Science Students go to Germany." Thomas Basin, Bishop of Lisieux, who suffered much at the hands of Louis XI., forms the subject of an article by Mr. F. C. Lowell; and William Cranston Lawton writes entertainingly of an archæological journey "From Venice to Assos." Miss Preston continues her series of articles by a paper entitled "Before the Assassination," giving an account of Cicero's closing years; and Miss Louise Imogen Guiney, under the name of "An Outline Portrait," writes a pleasant sketch about Lady Magdalene Herbert, mother to George Herbert. Mr. Hardy's serial, "Passe Rose," is concluded; Mr. James's "Tragic Muse" is continued, and the concluding portion of "Hannah Calline's Jim" also forms part of this number. The two short stories are "The King's Cup and Cake," by Sophie May, and "A Dissolving View of Carrick Meagher," by George H. Jessop. Mr. Bliss Carman, the young Canadian poet, contributes a long poem, "Death in April;" and Dr. T. W. Parsons, some verses called "In Eclipse." Criticisms of Renan's dramas and other recent books conclude the number.

—Sir Charles Dilke, in an article on "The Future of Russia," in the *Fortnightly Review* for March, says, "Not only is Russia the greatest military power in the world, but she is the European power with the largest homogeneous population and the greatest expansive force. Territorially she has the largest empire, possessing a vast share of the Old World; and hers is a people full of patriotic and religious spirit, and so well disciplined that all except an infinitesimal minority obey cheerfully and without question, under all circumstances, whether good or evil, the will of a single man. Yet, although subject to what, with our parliamentary ideas, we are disposed to style 'despotism,' the Russian people are full of spirit, and of those qualities which we consider specially Anglo-Saxon, — 'pluck' and 'go.' Russia has absorbed with rapidity, but with completeness, the greater part of central Asia, has drawn steadily nearer and nearer to our frontier, and has made herself extremely popular with the people she has conquered. Her policy throughout the century has been apparently fixed in object, but pursued with patience; and while there seems to be no reason to suppose any probability of a speedy collision, which England will do nothing to provoke, it is impossible for those who are charged with the defence of India to shut their eyes to the possibilities or even the probabilities of the future."

—The February number of the *American Journal of Psychology* opens with an interesting autobiography of a paranoiac, edited and commented upon by Dr. Frederick Peterson. The writer of the four-hundred-page manuscript book from which Dr. Peterson abstracts was a farm laborer, with a turn for study (he read Latin *con amore*) that helped to give him a remarkably direct literary style. The paper is interesting psychologically for the inside view it gives of the gradual development of his mental disease. Beginning life with hereditary predisposition, he grew up a hypersensitive and self-conscious child, a depressed and occasionally violent young man, suspicious of insult and persecution, contemplating murder in revenge, and finally reached the hallucinations and delusions of a typical paranoiac. His delusions of grandeur were colored by his reading of the Bible. First he found coincidences with his own experience. By degrees he recognized these less and less as coincidences, and regarded them more and more as prophetic, till at last he was ready to announce himself as the expounder of a new religion. His sufferings were the world's expiation, whence the title of his book, "The Piling of Tophet and the Trespass Offering." Though unable to correct his aberrations, he was a keen observer of his own mind, coherent, logical, and, like many of his class, not without at times a shadowy recognition of his true condition. The other two papers are continuations from the last number. Dr. W. H. Burnham brings down his survey of the doctrine of memory from Zanotti and his fantastic explanation of the association of ideas by their "electricity and magnetism," to Hering and Creighton. The theories held by the disciples of Hartley, by Kant and his followers, by the Scottish

school, by the English associationists, by the exponents of the "new psychology," are all considered; and finally, the modern theory of "organic memory," the beginnings of which, it appears, are to be found in Malebranche. Dr. E. C. Sanford discusses the variations produced in the amount of the personal equation by the kind of the heavenly body observed, by the magnitude of the star, by its rate and apparent direction of motion, and by the psychic and other conditions of observation. The reality of these changes seems demonstrable, and the law of their cause is not always clear. They furnish rather suggestive points for physiological and psychological research, than generalizations that can be taken ready-made into either science. This number contains the usual abundance of reviews and notes on psychological literature; "Nervous System," by Dr. H. H. Donaldson; "Hypnotism, Experimental and Abnormal," by Professor Joseph Jastrow. Rather prominent under the second heading are a number of abstracts from the rapidly growing literature of therapeutic hypnotism.

—The R. S. King Publishing Company, Chicago, have in press "The Story of America," by Elia W. Peattie, an historic narrative, arranged especially for young people. Many of the illustrations have been designed and engraved especially for this book. It is intended to be used as a text-book or supplementary reader in schools, as well as for general reading.

LETTERS TO THE EDITOR.

**Correspondents are requested to be as brief as possible. The writer's name is in all cases required as proof of good faith.*

The editor will be glad to publish any queries consonant with the character of the journal.

Twenty copies of the number containing his communication will be furnished free to any correspondent on request.

The Soaring of Birds.

SINCE my return to Cambridge, I find that a rather extensive correspondence has collected upon the above subject. I admit the force of Mr. Gilbert's criticism on the medium with uniform motion, and, that being the case, need not defend the theory from the criticism of Professor MacGregor, further than to say that the force which he calls number (2) is not due to friction, and that he has misunderstood my meaning. As the original theory, in that form, is withdrawn, it is unnecessary to discuss it further in *Science*.

In regard to Mr. Gilbert's explanation, I must say that I cannot yet accept his horizontal-layer theory. The very essence of a bird's soaring is that he shall continually rise higher and higher, not continue to circle at one level. If the bird rises higher and higher, we must have a succession of these layers of air, the upper ones a few thousand feet from the ground moving with a velocity very much higher than is usually attributed to the clouds, or else a series of layers moving alternately fast and slowly, which seems to involve an hypothesis which we have no other ground save this theory for believing.

Moreover, if all the bird has to do is merely to dip from one moving layer of air into another, why should not small birds soar? Take the swallow, for instance, — a most excellent flier, and quite capable of travelling with outstretched wings for a few seconds; yet he is never known to maintain himself in the air circling for five or ten minutes at a time, or by the hour together, as do the larger birds.

But why make any new assumptions with regard to the atmosphere? Why not take the phenomena with which we are all of us familiar? Whenever there is a high wind, such as is undoubtedly required by a soaring bird, we know that the air-pressure is not uniform, that the wind comes in gusts. Those familiar with mountain summits know that the same phenomena are observed in the upper atmosphere as at the surface of the ground. If we were travelling along with such a wind in a balloon, the gusts would not be so severe, but they would be of longer duration.

A ————— B

Imagine, now, a bird travelling from A to B, in the same direction as the wind, and with its mean velocity. When the wind is uniform, it seems to him that he is in a dead calm. When a gust comes, the wind seems to blow from A. It carries him along faster; and when it ceases, the wind seems to blow from B. It therefore affects him precisely as if he were in an alternating current of wind.

Suppose, now, that he is drifting towards *B* with a velocity equal to that of the wind, and travelling at right angles to *AB* with such a velocity that he can move along horizontally without falling towards the earth. Suddenly a gust overtakes him from the direction of *A*. He at once turns towards it, and his velocity relative to it is sufficient to raise him in the air. It tends to carry him more rapidly towards *B*; and when his velocity relative to it has sunk to the same value as before, and he again travels horizontally, he turns again at right angles to the line *AB*, but in the opposite direction to that which he had before. Presently the force of the gust diminishes, and the wind seems to blow towards him from the direction *A*. He accordingly turns towards it again, rising from the ground till his velocity relative to the air has assumed its former value, and he moves horizontally, turning again at right angles to the line *AB*, and the cycle is completed. He thus moves along in the direction *AB* with a mean velocity equal to that of the wind, rising when moving parallel to it, and moving horizontally, or perhaps slowly falling, if the gusts do not come with sufficient frequency, when moving at right angles to it.

In the case of all soaring birds, the spread tail, being an inclined curved surface, presents a large area to the wind. As it is situated at a considerable distance from the bird's centre of gravity, it must convert him into a sort of floating weather-cock, the wings serving as dampers to restrain him from turning too quickly. It therefore appears, if soaring really does depend on the interaction of varying wind-currents, as if the changes of direction involved must be almost automatic, and not a thing which the bird is required to learn; although he may doubtless learn to take advantage of favoring currents by giving proper inclinations to his wings and tail.

If the question be raised as to the sufficiency of the varying intensity of the wind-currents to maintain the bird's initial velocity against the resistance of the air, we must reply that it is a matter which can only be determined conclusively by experiment. Certain it is, however, that in windy weather the wind does come in gusts. If in the course of his circles the bird happens to be travelling at right angles to the wind, when the gust strikes him he will surely be turned round, almost in spite of himself, so as to face the gust. If the bird does face the gust, it will certainly raise him to a higher level.

If this explanation proves to be the true one, the reason why small birds cannot soar is probably, that, in those of them that have suitably shaped wings and bodies, their surfaces are so large in proportion to their weights that they rapidly assume the velocity of the surrounding air. In order that they might soar to advantage, the gusts should come more frequently, and be of shorter duration, than we actually find to occur in nature.

WM. H. PICKERING.

Harvard Observatory, Cambridge, Mass., March 21.

Definition of Manual Training.

I HAVE just seen in your pages (*Science*, xiii. p. 9) the excellent definition of "manual training," given by the New Jersey Council of Education. But the name is already too familiar in various vaguer uses, and especially for training to fit for manual labor; hence there would be great advantage if a fresh name were applied. Would not "manu-mental training" do admirably? It expresses the precise idea in such a way that a mistake as to its meaning is impossible.

J. E. CLARK.

Bootham, York, Eng., March 15.

Curves of Literary Style.

AFTER reading the communication on "Curves of Literary Style," in the last number of *Science*, I counted the words in 300 sentences towards the last of Carlyle's "French Revolution," and found the curve, when plotted, to agree very closely with your correspondent's as published, though there were several longer sentences interspersed, showing that the passages examined were from a different part of the work. This was very satisfactory; but the same method of examination, applied to the first 300 sentences of Carlyle's "Sartor Resartus," gives a very different result, the curve corresponding pretty closely with that given for Johnson's "Rambler." This goes to show, if it does not prove, that for detective purposes

the method is valueless. All compound words and phrases connected by hyphens were counted as single words only. The 300 sentences filled 30 out of 200 pages of the edition used.

H. A. PARKER.

Cambridge, Mass., March 25.

The Velocity of Storms as related to the Velocity of the General Atmospheric Movements.

It has for a long time been maintained by some meteorologists that the chief cause of the progressive movement of storms is that these atmospheric disturbances are carried along by the general movements of the atmosphere, as eddies on the surface of a river are borne along by the current in which they exist. The German meteorologists Van Bebber and Köppen have especially insisted on these views, maintaining that the direction and velocity of storms are determined by the mean motion of the entire atmosphere in which they exist; and Gen. Greeley has recently, in the *American Meteorological Journal*, educed the recorded wind-velocities on Mount Washington as favoring this view.

In order to study this and allied questions, the writer began two years ago a systematic series of observations on the clouds. These observations were made hourly between 7 A.M. and 11 P.M. Facil-

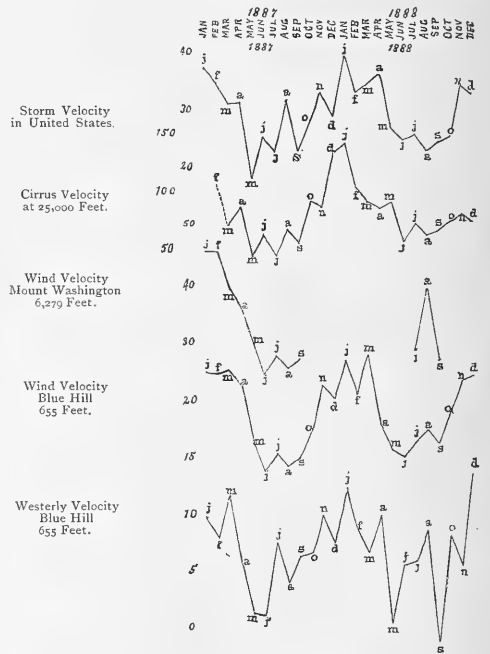

ities were not available for obtaining the actual velocities of the clouds, and it was hence necessary to be content with obtaining the apparent velocities. These were obtained by means of a nephoscope devised by the writer. The nephoscope consists of a horizontal mirror held in a frame carrying an eye-piece movable along vertical and horizontal arches, so that the direction of cloud-movements can be determined in degrees of azimuth. To obtain the relative velocity, a movable support is so arranged, that, when the observer's forehead is rested on it, the retina of the eye is maintained at a constant height of seven inches above the surface of the mirror. When the eye is in this position, the number of quarter-inches which the image of a cloud is seen to move across the mirror in a minute is taken as the relative velocity of the cloud. It is evident that the relative velocity of the cloud thus obtained bears a relation to the actual velocity; and, if the height of the cloud be known, its absolute velocity relative to the earth's surface

can be calculated. From measurements made at Upsala and elsewhere, it seems safe to assume that the average height of the highest form of clouds, which are known as cirrus and cirro-stratus, is 25,000 feet as a minimum estimate; and on this basis it is calculated by the writer, according to known geometrical principles, that, if the relative velocities obtained by him for this form of cloud be multiplied by ten, they will represent approximate absolute velocities. This, however, does not alter, but merely increases, the number of divisions in the scale used for the observed relative velocities; and, even if the attempt to express the results in approximate absolute velocities is erroneous, it does not alter the main conclusions of the following article, which are based on the measured apparent velocities of the cirrus as seen from the earth's surface.

Observations on the relative velocity of the clouds were begun in February, 1887; and during the two years 1887 and 1888 there were obtained 1,821 observations of the relative velocity of the cirrus level of clouds, distributed as follows:—

	1887.		1888.	
	No Days.	No. Observ.	No. Days.	No. Observ.
January.....	0	0	19	58
February.....	3	12	18	74
March.....	11	39	18	59
April.....	21	61	19	89
May.....	23	131	16	91
June.....	21	124	23	163
July.....	25	107	22	117
August.....	19	102	2	110
September.....	10	44	13	73
October.....	17	78	14	54
November.....	19	89	15	49
December.....	10	33	18	64
Year.....	179	820	217	1001

To correct for irregularities in the intervals between observations, the months were divided into six periods of about five days each, and averages for each period determined. From the average of these the monthly average was obtained. During the two years there were only three of these periods of five days within which no observations of the cirrus velocity were obtained.

The following numbers obtained as stated above express approximately in miles per hour the average monthly velocity of the cirrus obtained during two years (February, 1887, to January, 1889): January, 120; February, 106; March, 80; April, 85; May, 67; June, 58; July, 57; August, 64; September, 60; October, 81; November, 81; December, 102; year, 80.

Individual velocities exceeding 200 miles per hour were not uncommon in the winter months; and, even if these very rapidly moving cirri did not exceed 20,000 feet in height, their velocities must have been greater than 150 miles. In the accompanying diagram are plotted for each month during nearly two years the following data: the average monthly storm-velocities in the United States, as obtained from the United States Signal Service *Weather Review*; the average monthly velocity of the cirrus observed at Blue Hill Observatory; the average wind-velocity obtained during a part of this time on Mount Washington; the average wind-velocity obtained at Blue Hill Observatory; and the average westerly component of the Blue Hill wind-velocity. The westerly component was calculated by multiplying the north-west and south-west winds observed at Blue Hill by $\cos 45^\circ$, and adding the results to the wind-movement from the west, then subtracting from this the easterly wind-movements treated in the same manner. The result gave the excess of the westerly component of the atmospheric movement.

The observed direction of the cirrus movement was almost invariably from some westerly point, movements from the east only

being observed on about a dozen days during the two years: hence no correction for direction was attempted.

It is seen that all of the curves follow the same general sweep, indicating that the velocity of storms is intimately related to the velocity of movement of the general atmosphere; but the most intimate relation between the two is evidently in the cirrus region. The curves show that almost every increase or decrease in cirrus-velocity was coincident with a corresponding increase or decrease of storm-velocity. The first letters of the months are placed along the curves so that the corresponding parts can be more easily followed. In general, the minor oscillations of the curves representing the lower winds, were in opposite direction to those of the cirrus; but it seems worthy of notice that the only part of the storm-curve which differed from the cirrus-curve followed very closely the curve showing the westerly movement of the wind at Blue Hill.

In order to determine whether the relation between the upper air movements and the storm-velocity was a constant, the months which showed average cirrus-velocities between 30 and 50 miles per hour, were combined and averaged, as were also the average storm-velocities for these same months. In the same manner the cirrus-velocities between 50 and 70 miles, and the storm-velocities for the same months were averaged; and so for each 20 miles of increased velocity of the cirrus-level. The following table gives the results:—

	30-50	50-70	70-90	90-110	130-150
Cirrus-velocity.....	30-50	50-70	70-90	90-110	130-150
Average.....	44	61	80	94	136
Storm-velocity.....	20	25	30	32	34
Ratio.....	2.2	2.4	2.7	2.9	4.0

This shows that the cirrus-velocities increased more rapidly than the storm-velocities. A more detailed study, which is not given here, showed that this held true for winter as well as summer, and also showed that the most frequently observed cirrus-velocity was about 60 miles per hour.

A similarly prepared table showed that the storm-velocity increased more rapidly than the wind-velocity at Blue Hill; while the ratio between the two at the height of Mount Washington seems to be almost a constant (see *American Meteorological Journal* for December, 1888).

The following table, prepared in the same manner as that above, shows how intimately also the variability of the weather is connected with the velocity of the cirrus. The variability of the pressure and temperature at Blue Hill Observatory was found by ascertaining how much the means of consecutive days differed from each other, and averaging the results without regard to sign. The variability of rain was calculated on the basis that rain on every alternate day would make 100 per cent:—

	30-50	50-70	70-90	90-110	130-150
Cirrus-velocity.....	30-50	50-70	70-90	90-110	130-150
Average (in miles).....	44	61	80	94	136
Mean daily change in pressure.....	0.11 in.	0.12 in.	0.18 in.	0.19 in.	0.23 in.
Mean daily change in temperature.....	3.8°	4.2°	5.3°	6.4°	7.8°
Rain variability (in per cent).....	19	37	39	31	51

There has been a striking contrast between the velocity of the cirrus observed during the winter of 1887-88, and during the winter of 1888-89 up to the present time; and this is no doubt correlated with a striking contrast in the distribution of temperature during the two winters. During the winter of 1887-88 the temperature in the northern part of the United States was decidedly below normal, while in the southern part it was above. This, no doubt, very much increased the normal pressure-gradient from the equator toward the pole in the upper air; and as a consequence the upper-air movement was very rapid, carrying the cyclonic eddies along with exceptional rapidity, and causing rapid and violent fluctuations in the temperature, rainfall, humidity, etc., over the entire United States except the Pacific coast. On the other hand, during

the winter of 1888-89 the temperature has been decidedly above the normal in the northern United States, and normal or below normal in the Southern States. As a consequence the pressure-gradient in the upper air has been less steep than usual, the movements of the upper-air currents and of storms has been comparatively slow, and the winter over the entire country exceptionally free from sudden changes. The correlation of these facts seems to the writer to promise much; for, when the causes governing the distribution of temperature are better understood, it seems evident that the meteorologist will be able to foretell for considerable intervals the special characteristics of the weather to be expected over large areas.

I trust these few facts may serve to further stimulate the interest which is now being aroused in more exact and detailed cloud-observations.

H. HELM CLAYTON.

Blue Hill Observatory, Readville, Mass., March 20.

The Robinson Anemometer Factor.

THIS name has been commonly applied to the earliest expression of the law of relation between the velocities of the centres of the cups of the Robinson anemometer and that of the wind which sets them in rotation. Being a simple ratio between the two velocities

in question, or $\frac{w}{v}$ as expressed in *Science* (xiii. p. 227), it is not

surprising that subsequent experiments should show, that not only is the original factor, namely 3, incorrect, but that such a simple relation can by no means be made to express with any reasonable accuracy the anemometer law. It is surprising, however, considering the numerous experiments made by Dohrandt as well as others, that writers and investigators of the present day should still adhere to the use of the old anemometer "factor," and group together in a general mean a large number of experiments at different velocities.

The writer of the communication referred to above, in a discussion as to just what constitutes the true anemometer factor, has presented the matter in a form that shows at once how futile it is to use the old factor. Following Dohrandt and others, he assumes that the velocity of the wind, w , and the velocity of the cup-centres, v , bear the following relation to each other:—

$$w = a + bv \quad (1),$$

in which a and b are constants. The anemometer factor then becomes

$$x = \frac{wb}{w-a}.$$

We see from this equation, that, when $w = a$, x becomes infinite, which corresponds to the condition when the wind is just too feeble to start the cups. As w increases, x approximates more and more to the value of b ; but, even between the small ranges of velocities that occur in ordinary practice, x is entirely too variable to consider constant, as shown by the values given in the above-mentioned paper, and is too troublesome to use in calculation, especially since the very equation from which it is computed is in much simpler form, and, moreover, gives at once the velocity of the wind from the cup-velocity, which is the quantity observed when the anemometer is in use. The facts of the case, however, are not satisfied with even this degree of complication, and the anemometer factor becomes quite out of the question. Dohrandt's results up to 30 miles per hour are only approximately represented by an equation like (1); and as in his experiments, owing to the comparative shortness of the whirling arm, the friction of the anemometer at high velocities, from centrifugal action, was very great, it may be shown that the approximation is even closer than it actually should be. In fact, recent anemometer experiments upon a whirling arm 35 feet long are in most cases represented accurately by an equation of three terms: thus,

$$w = 0.225 + 3.14v - 0.0362v^2 \quad (2),$$

the numerical values being those computed for an anemometer of the Signal Service pattern, the cups of which are 4 inches in diameter on arms 6.7 inches long.

In view of this discussion, and taking into consideration that the experiments just mentioned were made in a closed court under the

most favorable circumstances, it would appear that the different conclusions reached by the wind force committee of the Royal Meteorological Society in their open-air experiments are largely misleading and in error, due probably to the serious influence of the outside wind-movement.

It seems that one effect of this wind-movement, outside of the motion of the arms of the whirling-machine, is not clearly understood, or at least receives little attention, and is nevertheless of the greatest importance.

If a uniform wind blows across the path of the anemometer when being carried upon the whirling-machine, every one sees, that, during one half of its motion, the anemometer is going more or less with the wind, and against it during the remaining half. That these effects do not fully neutralize each other, is clearly shown in a mathematical analysis by which it is not difficult to find the correction that should be applied; but this is only small in most cases, and is not very serious. A far greater error arises from the effect this extra wind has in causing a very large and rapid variation in the actual wind-movement experienced by the anemometer, which, if its axis is being revolved on the whirler at the rate of 15 miles an hour, and an extra wind of 4 miles per hour is blowing, is at one point of its path moving through the air at the rate of 19 miles an hour, and at the opposite point at the rate of only 11 miles per hour; the change, moreover, from the maximum to the minimum being accomplished with great rapidity. The mean velocity of the cups in this case may be shown to be such as corresponds to a wind-velocity of nearly 19 miles per hour, the reason being that the inertia of the cups keeps them spinning after experiencing the maximum velocity; so that during the minimum velocity they do not slow up as they should, the only tendency to do this being the air resistance to the backs of the cups; and, as this is considerably less than that felt by the front or concave sides of the cups when the wind tends to increase their velocity, it must follow that the mean velocity of the cups in a variable current is considerably higher than such as would otherwise occur. A more extended statement of this inertia effect, and numerous experiments by which the theory is confirmed, have been already submitted for publication in the *American Meteorological Journal*.

The large and erratic variations in the results obtained by the wind force committee with anemometers of the Robinson type are to be attributed to this cause; and the noticeably more uniform results obtained with the helicoid anemometer were due to the fact that this instrument, being driven by the direct pressure of the wind, and not by the difference of several pressures as is the case with the Robinson anemometer, is not subject to the inertia effect just described. The explanation of this point, given in *Science* of March 22, p. 227, to the effect that the helicoid anemometer was tested with a vane attached to keep it in the wind, is hardly sufficient to account for its seeming better performance.

It follows from the above, that, if two sets of anemometer cups are fitted up exactly alike except in weight, one having paper cups, for instance, the latter will in the open air, exposed to a variable wind, give seemingly less wind than the former, both being reduced by the same formula. Formula (2) given above is also only to be used for perfectly uniform currents.

Some mention was made in a "Note on the Robinson Anemometer Constant," in *Science* of March 15, of the relative merits of the recently invented helicoid anemometer and those of the Robinson type. Judging by the description of the former, its mechanical construction cannot possibly be so simple as that of the latter; and as to what would happen to it and its delicate self-adjusting vanes when exposed to the sleet and frost of a winter season, is by no means difficult to tell. The inventor himself considers the instrument defective or unsatisfactory, owing to the ease with which the readings are altered by bending the vanes.

Robinson anemometers, to give the most satisfactory results in the open air, and variable winds, should have very light cups.

It may be added, in conclusion, that all anemometers acting by direct wind-pressure are subject in much greater degree to variations in their law connected with temperature and pressure changes than are those depending only on difference of pressures.

C. F. MARVIN.

Washington, D.C., March 25.

GUARANTY INVESTMENT COMPANY

CAPITAL \$250,000.

Offices: Atchison, Kan. 191 Broadway, New York. 222 Walnut St., Phila.

Hon. ALBERT H. HORTON (Chief Justice, Kansas Supreme Court), Topeka, Kan., Pres't.

7% Guaranteed Farm Mortgages 7%

The Guarantee Investment Company makes loans upon fertile farms in the choicest portions of Kansas and Nebraska and has adopted the policy of sending a Committee of its Investors each year to examine its loans and methods of business.

The Committee this year consisted of PROF. A. H. BERLIN, Principal of the High School Montrose, Pa., and MAJ. THEODORE L. POOLE, Ex-U. S. Pension Agent, Syracuse, N. Y. Both of these gentlemen are persons of the highest character and have the confidence of the Communities in which they reside.

The Committee has recently returned and has made a very interesting Report upon the general development of Kansas and Nebraska as well as the business of the Company. The Company will be glad to send this Report to any address.

The following names are taken from the long list of Investors in our Mortgages:

(See if Some Friend of Yours is not in the List.)

William A. Caudwell, 39 Liberty St., N. Y.
 Palmer Cox, 658 Broadway, N. Y.
 Rev. Jos. H. Rylance, D.D., 11 Livingston Place, N. Y.
 Rev. Brady E. Backus, D.D., 360 West 28th St., N. Y.
 Rev. R. M. Sommerville, 156 West 45th St., N. Y.
 Dr. Robert A. Murray, 235 West 23d St., N. Y.
 Dr. James P. Tuttle, 126 West 41st St., N. Y.
 H. Edwards Rowland, 218 Fulton St., N. Y.
 Irving H. Tift, Esq., 271 Broadway, N. Y.
 Prof. D. G. Eaton, 35 Pineapple St., Brooklyn, N. Y.
 Dr. F. P. Thwing, 126 St. Marks Ave., Brooklyn, N. Y.
 Dr. C. C. Miles, Greenport, N. Y.
 John V. N. Bergen, Fort Jefferson, N. Y.
 Benj. W. Schiwell, Yonkers, N. Y.

R. C. Coleman, Goshen, N. Y.
 Mrs. Samuel Carlisle, Newburg, N. Y.
 Dr. C. C. Bartholomew, Ogdensburg, N. Y.
 Rev. Nelson Millard, D.D., Rochester, N. Y.
 Rev. Horace G. Hinsdale, D.D., Princeton, N. J.
 Dr. Charles M. Howe, Passaic, N. J.
 George A. Skinner, 5 Railroad Place, Newark, N. J.
 Dr. Edwin M. Howe, 85 Halsey St., Newark, N. J.
 Dr. H. G. Buckingham, Clayton, N. J.
 Dr. Martin Cole, Jr., Hainesville, N. J.
 Mortgage Trust Co. of Pa., Philadelphia, Pa.
 Miss Mary Miller, 1230 Spruce St., Philadelphia, Pa.
 Henry D. Biddle, 213½ Walnut St., Philadelphia, Pa.

Dr. Calvin C. Halsey, Montrose, Pa.
 Rev. William Baldwin, Great Bend, Pa.
 Gen. William Lilly, Mauch Chunk, Pa.
 Second Nat. Bank, Mauch Chunk, Pa.
 Enos E. Thatcher, West Chester, Pa.
 Mrs. Townsend Poore, Scranton, Pa.
 Rev. Burdett Hart, D.D., New Haven, Conn.
 Dr. Frank H. Wheeler, New Haven, Conn.
 Charles R. Christy, Stamford, Conn.
 Mrs. Catharine P. Fuller, Woodmont, Conn.
 Miss Jessie Henderson, Lenox, Mass.
 Dr. M. J. Halloran, Worcester, Mass.
 Albert Walker, Bennington, Vt.

Address for Report and Monthly Bulletin

HENRY A. RILEY, General Eastern Manager, 191 Broadway, N. Y.

ONE LANGUAGE FOR THE WHOLE WORLD.

WORLD-ENGLISH :

THE UNIVERSAL LANGUAGE. 25 CENTS.

EVERY one has heard of the butcher who, after a long search for his knife, at last found it in his mouth : so speakers of English have been seeking for a universal language, when, lo ! it is in their mouths. The intelligibility of English words has been obscured by a dense mist of letters. This is now dispersed by A. Melville Bell, who has already won a world-wide reputation through his invention of "Visible Speech," the great boon to deaf-mutes. Professor Bell calls this new discovery of his "World-English," and the result is a language which cannot fail to meet with acceptance, and at once supersede the supposed necessity for "Volapük," or any other artificial language. No language could be invented for international use that would surpass English in grammatical simplicity, and in general fitness to become the tongue of the world. It is already the mother-tongue of increasing millions in both hemispheres, and some knowledge of the language is demanded by all educated populations on the globe. Social and commercial necessities require that the acquisition of this knowledge shall be facilitated, and it is believed that Professor Bell's invention has removed the last impediment to English becoming the universal language, for which vague desires have long been entertained, although hitherto only futile efforts have been made.

Ex-President Andrew D. White, of Cornell University, says: "I believe that the highest interests of Christian civilization and of humanity would be served by its adoption. China and Japan would be made English-speaking peoples within fifty years, and so brought within the range of Christianizing and civilizing ideas, in the largest sense. All existing missionary work is trivial as compared with this. For your system would throw wide open those vast countries, as, indeed, all the countries of the world, to the whole current of English and American thought."



For Diffusion of English throughout the World

THE UNIVERSAL LANGUAGE

This "Hand-Book of World-English" is the Complete, Simple, and Efficient Medium.

FOREIGNERS

Will Acquire, by Means of this Hand-Book, a PERFECT PRONUNCIATION OF ENGLISH.

For Primary School Pupils and Illiterate Adults

World-English is a Royal Road to Reading.

To Teachers of English and Modern Languages

This Hand-Book will be of Primary Importance as a Phonetic Directory.

DEFECTS OF SPEECH

Will be Readily Corrected by Means of the Articulative Directions in this Hand-Book.

HAND-BOOK OF WORLD-ENGLISH,

25 CENTS.

The plan of this little book is altogether new. Letters and sounds are so associated, in all the exercises, that from the mere knowledge of letters a learner cannot fail to pronounce words with certainty. English reading will thus be easily acquired, whether by natives or foreigners, children or adults.

The general resemblance of World-English to Literary English is such that any reader of the latter deciphers the former at sight, or, at most, after a few minutes' study of the new letters. A like result may be anticipated for those who shall learn to read from World-English. They will transfer their power of reading to the literary form of the language, almost without effort. The orthographic aspect of words will, besides, be so fixed in the eye, by contrast, that spelling will be remembered as — what it really is — a pictorial association with words.

No special training is required to qualify teachers for using this book. The subject can even be successfully introduced in the kindergarten and the nursery. This phonetic mode of initiation in reading cannot be too strongly urged on the attention of School Boards on both sides of the Atlantic.

The ordinary orthography of each word is interlined with the World-English version throughout the Exercises and Readings.

So set down, our tongue is the best for the world to unite upon.—*Brooklyn Eagle*.

The idea of Mr. Bell has much to recommend it, and the presentation is charmingly clear.—*American, Phila.*

The result is a language which cannot fail to meet with acceptance.—*Boston Traveller*.

Has the merit of great ingenuity.—*Railway Age*.

His treatise, as a study of English orthoepy, condenses the result of much thought and experience in small compass.—*The Critic*.

World-English deserves the careful consideration of all serious scholars.—*Modern Language Notes*.

World-English is the English language unburdened of its chaotic spellings.—*Popular Science Monthly*.

We commend it to the attention of teachers.—*Ottawa Globe*.

"World-English" and "Hand-Book of World-English" can be had of all booksellers, or will be sent for 50 cents, post free, by the publisher,

N. D. C. HODGES, 47 Lafayette Place, New York.

The Make-up of
SCIENCE

has been
changed recently to
render it
MORE ATTRACTIVE

For Sale
on the
News Stands.

Any one who will have the following blank filled out by a responsible Newsdealer, and mailed to us, will be allowed a three months' subscription to *Science*.

N. D. C. HODGES,
47 LAFAYETTE PLACE, NEW YORK.

To the News Company.

You may add to my regular order five copies of *SCIENCE* each week (returnable).

A NEW MAGAZINE—THE SWISS CROSS
Devoted to spreading a love of nature among the people. Edited by HARLAN H. BALLARD, President of the Apeasiz Association, and succeeding *St. Nichol* as the official magazine of that body. \$1.50 a year. Sample copy 10 cents, or 25 cents for trial subscription for 3 months.
N. D. C. HODGES, PUBLISHER,
Mention this paper. 47 Lafayette Place, New York.

Wants.

A YOUNG MAN can have lucrative engagement, not only a fixed salary, but according to his work accomplished in travelling for *SCIENCE*. A personal interview invited.
N. D. C. HODGES,
47 Lafayette Place, New York.

Old and Rare Books.

A. S. CLARK, Bookseller,
34 PARK ROW, NEW YORK CITY.
A Gleaner in the By-ways of Literature. Results of Gleaning found in Catalogues issued from time to time.
CATALOGUE NO. 27 NOW READY.

BACK NUMBERS and complete sets of leading Magazines. *Rates low.* AM. MAG. EXCHANGE, Schoharie, N.Y.

H. WILLIAMS,
Dealer in Old Magazines, Reviews, &c. Scientific periodicals a specialty. 39 Macdougall St., N.Y.



PETER COOPER'S GLUE.
Prepared in liquid form by the N.Y. Liquid Glue & Adhesive Co. The long and well-known reputation of this glue for its strong adhesive properties requires no recommendation. It is the glue your furniture is glued with, and never fails to join the hardest of wood if properly applied. Always ready for use. For sale everywhere.
CONTAINS NO ACID.

Unalterable & Fragrant
GLUE PASTE
A strong and harmless preparation of flour and glue for Photographers, Manufacturers, Merchants, Insurance Companies, Banks, and family and office use. Contains no acids. Unlike Mucilage, adheres and dries immediately. N. Y. Liquid Glue and Adhesive Co., Preparers of Peter Cooper's Glue in Liquid Form, 18 N. William St., New York. *Used in this office.*



SCIENCE CLUBBING RATES.

10% DISCOUNT.	Year's Subscription.	With Scales.	With The Swiss Cross.
We will allow the above discount to the subscriber to <i>Science</i> or <i>The Swiss Cross</i> who will send us an order for periodicals exceeding \$10, counting each at its full price.			
American Agriculturist.....	\$ 7.50	\$ 4.30	\$ 5.00
American Analyst.....	1.00	4.25	2.25
American Architect and Building News.....	10.00	12.80	11.00
Imperial edition.....	7.00	9.80	8.00
Gelatine ".....	6.00	8.80	7.00
Regular ".....	1.00	4.25	2.25
American Gardener.....	3.00	6.25	4.25
American Journal of Philology.....	2.50	5.30	4.50
American Machinist.....	3.00	5.80	4.00
American Naturalist.....	4.00	7.50	5.50
Andover Review.....	4.00	6.80	5.00
Atlantic.....	4.00	6.80	5.00
Babyhood.....	1.50	4.30	2.50
Babylond.....	1.50	3.25	2.75
Breadstret's.....	5.00	6.00	6.00
Brain.....	3.50	6.30	4.50
Building (weekly).....	6.00	8.80	7.00
Carvers and Building.....	4.00	7.45	5.25
Century Magazine.....	4.00	6.80	5.00
Chautauquan, The.....	1.50	4.30	2.50
Christian Union, The.....	3.00	5.80	4.00
Christian Weekly, Illustrated.....	5.00	5.30	3.75
Cosmopolitan, The.....	2.00	5.80	4.00
Critic.....	3.00	5.80	4.00
Doctor.....	2.00	4.80	3.00
Electric Magazine.....	5.00	7.50	5.50
Edinburg Review.....	4.00	6.80	5.00
Electrical World.....	3.00	5.80	4.00
Electrician and Electrical Engineer.....	3.00	5.80	4.00
Electrical Review.....	3.00	5.80	4.00
Engineering and Mining Journal.....	4.00	8.00	6.00
English Illustrated Magazine.....	1.75	4.55	2.75
Family Story Paper (N.Y.).....	3.00	5.80	4.00
Forest and Stream.....	4.00	6.80	5.00
Iron Age (weekly).....	4.00	7.50	5.50
Godey's Lady's Book.....	2.00	4.80	3.00
Harper's Bazar.....	4.00	6.80	5.00
Harper's Magazine.....	4.00	6.80	5.00
Harper's Weekly.....	4.00	6.80	5.00
Harper's Young People.....	2.00	4.80	3.00
Health and Home.....	1.00	4.25	2.25
Herald of Health.....	1.00	4.25	2.25
Illustrated London News (Amer. reprint).....	4.00	6.80	5.00
Independent, The.....	3.00	5.80	4.00
Inter Ocean, The.....	1.00	4.25	2.25
Iron Age (weekly).....	4.00	7.50	5.50
Journal of Philology (Eng.).....	2.50	5.30	3.50
Journal of Speculative Philosophy (begins with Jan. No.).....	3.00	5.80	4.00
Judge.....	4.00	6.80	5.00
L'Art.....	5.00	14.80	13.00
Life.....	5.00	7.80	6.00
Lippincott's Magazine.....	3.00	5.80	4.00
Little's Living Age.....	8.00	10.50	9.25
Little Men and Women.....	5.00	7.50	5.50
London Quarterly.....	4.00	6.80	5.00
Macmillan's Magazine.....	3.00	5.80	4.00
Magazine of American History.....	5.00	7.80	6.00
Medical and Surgical Journal.....	5.00	7.80	6.00
Mechanical Engineer.....	2.00	4.80	3.00
Metal Worker.....	1.00	4.25	2.25
Microscope, The.....	1.00	4.25	2.25
Nature.....	6.00	8.80	7.00
New Princeton Review.....	3.00	5.80	4.00
North American Review.....	5.00	7.80	6.00
Outing.....	3.00	5.80	4.00
Overland Monthly.....	4.00	6.80	5.00
Pansy.....	1.00	4.25	2.25
Political Science Quarterly.....	3.00	5.80	4.00
Popular Science Monthly.....	5.00	7.80	6.00
Popular Science News.....	1.00	4.25	2.25
Portfolio, The.....	7.50	10.30	8.50
Practitioner.....	3.50	6.30	4.50
Public Opinion.....	3.00	5.80	4.00
Puck.....	5.00	7.80	6.00
Puck (German).....	5.00	7.80	6.00
Quarterly Review (London).....	4.00	6.80	5.00
Queries.....	1.00	4.25	2.25
Rural New Yorker.....	2.00	4.80	3.00
St. Nicholas.....	3.00	5.80	4.00
School Journal.....	2.50	5.30	3.50
Scientific American.....	3.00	5.80	4.00
Supplement.....	5.00	7.80	6.00
Architect and Builders' edition.....	2.50	5.30	3.50
Scribner's Magazine.....	3.00	5.80	4.00
Southern Cultivator.....	1.50	4.30	2.50
Springfield Republican (weekly).....	1.00	4.25	2.25
Sunday School Times.....	3.00	5.80	3.00
Teachers' Institute.....	1.25	4.05	2.25
Texas Siftings.....	1.00	6.80	5.00
Treasure-Trove.....	1.00	4.25	2.25
Truth Seeker; The.....	3.00	5.80	4.00
Wide Awake.....	2.49	5.20	3.40
Young Folks' Journal.....	1.00	4.25	2.25

N. D. C. HODGES,
47 Lafayette Place,
New York.

C. & C. ELECTRIC MOTOR COMPANY.

Electric Motors
FOR
Arc and Incandescent Circuits, Most Economical Motor on the Market.
Regulation Perfect.
Motors Designed for all Power Purposes.

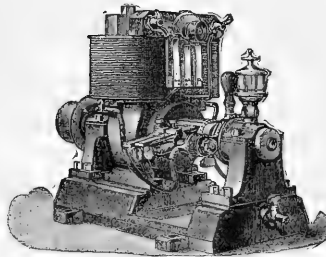

OFFICE and MANUFACTORY:
402 and 404 Greenwich Street, New York City.
New England Office, 19 Pearl St., Boston.
Philadelphia Office, 301 Arch St.
Western Office, 139-141 Adams Street Chicago.
Southern Office, 25 Carondelet Street, New Orleans.

Schools.

NEW JERSEY, PLAINFIELD.
THE CHESTNUTS.—Parents with daughters to educate, or orphan girls with companion, may find a comfortable home, with school instruction by applying to Miss E. E. Kenyon.

NEW YORK CITY, N. Y.
BOTANY, MICROSCOPY.—PRACTICAL courses at the New York College of Pharmacy open for ladies and gentlemen from April 10 to end of June, including botanical excursions and individual instruction in microscopic work. For particulars apply to College, 209-213 East 23d St., or to PROF. J. SCHRENK, Hoboken, N. Y.

CONNECTICUT, NEW HAVEN.
MRS. CADY'S SCHOOL FOR YOUNG LADIES. Prepares for Smith and Wellesley, and admits to Vassar by Certificate. Circulars. Early application necessary.

VERMONT, BURLINGTON.
VERMONT EPISCOPAL INSTITUTE. Boarding School for Boys. Prepares for College or Business. Military drill. Terms moderate. Fifty-seventh half-year opens September 3, 1888. Send for catalogue.
H. H. ROSS, A. M., Principal.

TERRE HAUTE, IND.
ROSE POLYTECHNIC INSTITUTE.—A School of Engineering. Well-endowed, well-equipped departments of Mechanical and Civil Engineering, Electricity, Chemistry, Drawing. Extensive Shops & Laboratories. Expenses low. For catalogue address T. C. Mendenhall, Pres.

Brokers and Auctioneers.

R. ELLIS & CO.

**BUSINESS, HOTEL and PATENT BROKERS,
AUCTIONEERS, ETC.**

No. 176 BROADWAY,

Room 46. **New York.**

CLIENTS Advised free of charge.

J. P. TRAVER & CO.,
General Auctioneers,
Real Estate and Business Brokers,
OFFICE, 23 PARK ROW,

OPPOSITE POST OFFICE, (ROOMS 14 & 15.) New York.

Mortgages Foreclosed. Cash Advanced on Consignments.
Property of Every Description Bought, Sold and Exchanged.

Scientific Apparatus.

J. GRUNOW,

621 Sixth Avenue, New York.
Established 1852.

MAKER OF

Microscope Stands,
Oil Immersion Objectives and Abbe Condensers for Bacterial and Histological work, of Objectives, Camera Lucida and other accessories apparatus.

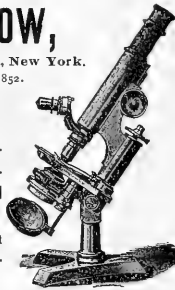

MORRIS EARLE & CO.

SUCCESSORS TO

R. & J. BECK,

1016 Chestnut Street Phila

Microscopes and all Accessories and Apparatus. Photographic and Photo-Micrographic Apparatus and Outfits.

Spectacles, Eye Glasses, Opera and Marine Glasses, etc.

Illustrated Price List mailed free to any address. Mention SCIENCE corresponding with us.



IMPROVED OIL LIGHT MAGIC LANTERNS.

Also Lime and Electric Light Apparatus, and mechanical, plain, and fine colored views.

J. B. COLT & CO., Manufacturers,

No. 16 BEEKMAN STREET, NEW YORK.

MAGIC LANTERNS Stereopticons and the Best Views for Public, Church, Home, and Scientific Exhibitions. Best apparatus, new views. Largest stock. Reduced prices. 24 Years' Practical Experience. Illus. Catalogue Free.

GEO. H. PIERCE,

136 S. Eleventh St., Philadelphia, Pa

ELECTRICAL TESTING BUREAU,

Johns Hopkins University, Baltimore, Md.
Resistance Coils and Boxes Compared.
Am meters and Volt meters calibrated.
Condensers standardized.
Primary and Secondary Batteries Tested.
Efficiency of Dynamos and Motors Determined.
Insulation of Cables and Wires Tested.
Etc., Etc.
Circulars describing Methods Used, Prices, Etc., sent on Application.
Address as above.



E. & H. T. ANTHONY & CO.

591 Broadway, N. Y.

Manufacturers and Importers of

PHOTOGRAPHIC INSTRUMENTS,

Apparatus and Supplies of every

description. Sole proprietors of the

Patent Detective, Fairy, Novel, and

Bicycle Cameras, and the

Celebrated Stanley Dry Plates.

Amateur Outfits in great variety, from \$5.00 upward.
Send for Catalogue or call and examine. ^{ESTD} More than 40 years established in this line of business.

WHITAL'S PLANISPHERES OR DIRECTORY OF THE STARRY HEAVENS name and locate all Stars, Constellations, and Planets visible at any given minute of time. Should be used by every one. Ask your stationer, or address WM. T. COOPER, Manager, 307 Race St., Philadelphia, Pa.

Readers of Science

Corresponding with or visiting Advertisers will confer a great favor by mentioning the paper.

TO EMPLOYERS.

Having purchased the fixtures, good will, &c., of the **NEW YORK EMPLOYMENT BUREAU**, at No. 631 BROADWAY, in this city, we request the patronage of the public in the future. We desire to fill a long-felt want for an employment bureau, where only the best grade of male help is dealt in, and it is our aim to send ONLY such help as is ordered in every instance, and our patrons can rely on us to send strictly first-class help, the references of whom we personally investigate before sending to any one. We simply request a trial, and are convinced that we will give satisfaction in every case. We have on hand help in every branch, which we can send upon receipt of telegram or letter, AND FOR WHICH WE MAKE NO CHARGE TO AN EMPLOYER.

NEW YORK EMPLOYMENT BUREAU,

(AS REORGANIZED.)

Arnold, Constable & Co.

SPRING STYLES DRESS FABRICS.

Plain and Hair-Line Batiste Cloths,
Printed Laines, Fancy Mohair,
Cheviots, Tweeds,
for Steamer and Travelling Dress.
Checked and Striped Suitings,
Broche and Embroidered Robes,
Cashmeres d'Ecosse, Henrietta Cloths,
IN NEW COLORINGS.
FOR STREET AND EVENING WEAR

Broadway & 19th St.
New York.

GINGHAMS, SATEENS, & LAWNS

Exquisite colorings are not confined to Silks. Cotton Dress Fabrics this season are more beautiful in design and shading than ever before.

The finest Scotch Novelty Gingham are from 18 cents to 60 cents per yard. Freres Koechlin's French Sateens, 30 and 35 cents per yard.

Printed Batistes 25 and 35 cents per yard; figured Lawns, all linen, 30 cents per yard; German Linen Dress Goods, plain, 35 cents, checks and Broche effects, 40 cents per yard.

Samples sent on request.

JAMES McCREERY & CO.
BROADWAY AND ELEVENTH ST
NEW YORK.

SPECIAL TEACHER'S EXCURSION TO

PARIS EUROPE AND THE
WORLD'S EXPOSITION,
visiting England, France, Germany, the
Rhine, Belgium and Holland. All travel and
hotels FIRST-CLASS. Finest line of Steamers crossing
the Atlantic. Low Rates. Rooms are being
rapidly taken. Send for Circulars.
E. TOURJEE, Franklin Square, Boston, Mass.

FOOD ADULTERATION

And its Detection. With photomicrographic plates and a bibliographical appendix. By J. P. Battershall. 328 pages, 8vo, cloth. Price, \$3.50. Circulars and Catalogues on application. E. & F. N. SPON, 12 Cortlandt St., New York.



KIMBALL'S STRAIGHT CUT CIGARETTES.

Unsurpassed in quality.
Used by people of refined taste.
Highest award at Brussels, 1888.
The finest smoking mixtures are of our manufacture.
Fifteen First Prize Medals.
WM. S. KIMBALL & CO.,
Rochester, N. Y.

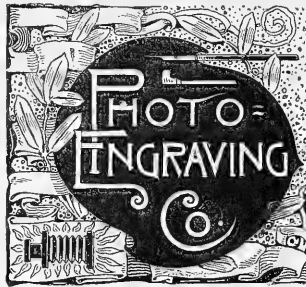

BRANCH AT 728 CHESTNUT ST
PHILADELPHIA, PA.

JOHN HASTINGS = Prest.
"A-R-HART" = Genl Manager
"JOS-TRIPP" = V Prest.

ENGRAVING FOR ALL ILLUSTRATIVE AND ADVERTISING PURPOSES

67-71 PARK PLACE
NEW YORK

THE CHEQUE BANK LIMITED.

ESTABLISHED IN LONDON, 1873.

CHIEF OFFICE, 4 Waterloo Place, Pall Mall, London.

TRUSTEES:

The Right Honorable JOHN BRIGHT, M.P.
The Right Honorable EARL BEAUCAMP.
Bankers: Bank of England.

The Capital of the Bank and its Guarantee Fund of 500 is invested in Government Securities.

The Bank does not discount Notes or Bills, nor speculate, but loans its Deposits against Government Securities, thus making the Cheque Bank Cheques EQUAL TO CASH—as Bank of England Notes are.

The Cheque Bank issues Cheques singly or in books from ONE POUND upwards, for the use of Travelers, and for others remitting money to Europe, available in every town in England, Scotland, Ireland, and Wales. In every town of Europe, and all other parts of the world.

Cheque Bank Cheques are accepted as Cash by all the British Government Offices.
VISITORS TO THE PARIS EXHIBITION this summer can get the Cheque Bank Cheques cashed at 50 Banking Houses in Paris.

Travelers and others holding Cheque Bank Cheques can have their mail matter addressed to them, care of the Cheque Bank, London, who will take charge of the same and forward to any address.

For Hand-Book containing List of upwards of 2000 of the principal Banking Houses throughout the World who Cash the Cheque Bank Cheques, and for all information, apply to the AGENCY.

CHEQUE BANK, Limited,
UNITED BANK BUILDING,
2 Wall St., New York.

E. J. Matheis & Co., Agents.

REFERENCES BY PERMISSION:
JNO. W. MACKAY, Esq., President Commercial Cable Company, Mackay-Bennett Cables, New York.

F. O. FRENCH, Esq., President Manhattan Trust Co., New York, and others.

KNABE PIANOFORTES.

UNEQUALLED IN

Tone, Touch, Workmanship and Durability.

WILLIAM KNABE & CO.
NEW YORK: No. 112 Fifth Av., above 16th St.
BALTIMORE: Nos. 22 and 24 E. Baltimore St.
WASHINGTON: No. 817 Market Space, Penn. Av., near 9th St.



GOOD NEWS TO LADIES.

Greatest inducements ever offered. Now's your time to get up orders for our celebrated Teas and Coffees, and secure a beautiful Gold Band or Moss Rose China Tea Set, Dinner Set, Gold Hand Moss Rose Toilet Set, Watch, Brass Lamp, or Webster's Dictionary. For full particulars address THE GREAT AMERICAN TEA CO., P. O. Box 299, 81 and 83 Vesey St., New York.

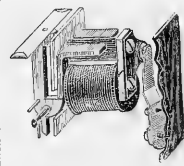

A
★
DROP
IN THE
PRICE
★
OF

GRAVITY DROP ANNUNCIATORS.

DON'T FORGET THE
DUST-PROOF BELLS.

HAZAZER & STANLEY,
32 Frankfort Street, N. Y.

**Scott's
EMULSION**
OF Pure
Cod-Liver
AND Oil
HYPOPHOSPHITES
ALMOST AS PALATABLE
AS MILK.

So disguised that the most delicate stomach can take it.

Remarkable as a
FLESH PRODUCER.
Persons gain rapidly
while taking it.

SCOTT'S EMULSION

Is acknowledged by Physicians to be the FINEST and BEST preparation of its class for the relief of CONSUMPTION, SCROFULA, GENERAL DEBILITY, WASTING DISEASES OF CHILDREN, and CHRONIC COUGHS.

ALL DRUGGISTS. Scott & Bowne, New York.

133452
 APR 6 1889
 MITCHELLIAN INSTITUTION

SCIENCE

[Entered at the Post-Office of New York, N. Y., as Second-Class Matter.]

A WEEKLY NEWSPAPER OF ALL THE ARTS AND SCIENCES.

SEVENTH YEAR.
 VOL. XIII. No. 322.

NEW YORK, APRIL 5, 1889.

SINGLE COPIES, TEN CENTS.
 \$3.50 PER YEAR, IN ADVANCE.

CRUDE PETROLEUM AS A FUEL.

THE substitution of crude petroleum for coal as fuel in many branches of metal-working, the heating of steam-boilers, etc., has received much attention in recent years. Many devices for feeding the oil to the furnace, controlling the size of the flame, and insuring safety from accident, have been tried, only to be condemned in

sufficient length of time to test it thoroughly in welding, tempering, annealing, enamelling, brazing, japanning, and all kinds of forging and melting of metals; and that the results are satisfactory is shown by the hearty indorsement and commendation given it by those who have it in use.

In this system compressed air is used to atomize the oil, the air-pressure being so regulated as to insure the complete combustion

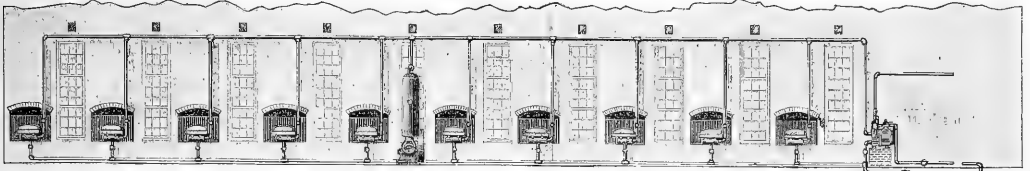

FIG. 1.—FORGES BURNING CRUDE PETROLEUM.



most cases. These devices depended upon either a steam jet to atomize the oil at the point of ignition, or a system of retorts to heat the oil and convert it into gas before being burned. These systems compel the use of more or less apparatus in the fire-box or furnace; in some cases the retort being placed therein, and in others the fire-box being partly filled with fire-brick or other

of the oil, and to preserve a uniform degree of heat of any intensity desired. There are no obstructions placed in the fire-box; so that it is at all times ready to receive coal or other fuel, should the oil-supply fail or a change of fuel be desired. Other good points about this system are its cleanliness and freedom from odor, which are vouched for by those who use it.

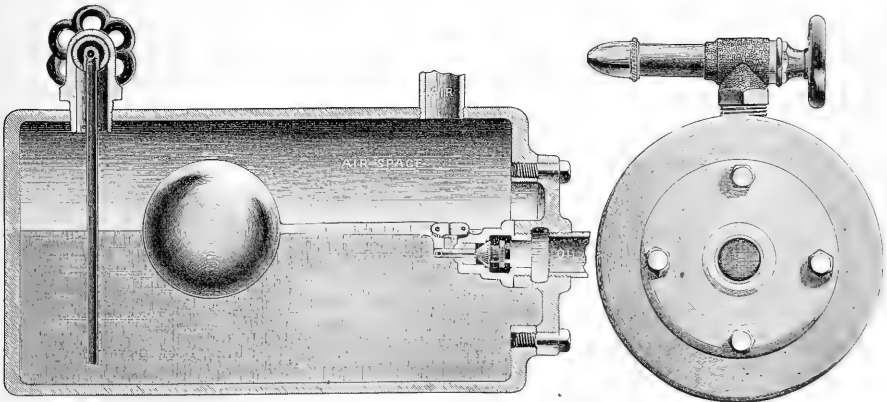

FIG. 2.—AERATING CYLINDER FOR PETROLEUM BURNER.

fractory material, to be heated, and then used as a means to ignite the fuel, distribute the flame, and equalize the heat.

A new method of utilizing crude petroleum for the purposes mentioned is being introduced to public notice by the Aerated Fuel Company of Springfield, Mass. This method has been in use a

The application of this system to forge-fires is shown in Fig. 1, which is a picture of one side of a plant for the forging of nuts and bolts in the works of the Upson Nut Company at Cleveland, O. It is claimed that in works of this kind, the cost of oil for fuel is much less than that of coal; while the dies with which the forging is

done wear longer, as there is less scale on the work. Moreover, the heat is uniform, and can be maintained from morning till night without cessation, enabling the workmen to do more and better work; and there is no smoke, dust, or ashes.

Fig. 2 shows the interior of a burner cylinder with oil inlet at the end. The supply of oil is maintained at a constant level by means of the float, which controls the oil-valve. An end view of the cylinder

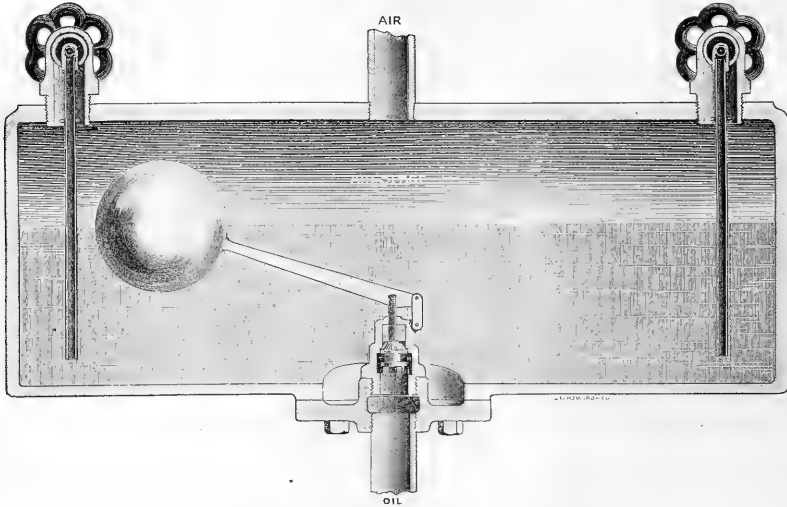

FIG. 3.—AERATING CYLINDER FOR DOUBLE PETROLEUM BURNER.

is also given, showing the burner, and the hand-wheel which regulates or cuts off the supply of air and oil. The operation of the mechanism is as follows: Oil is forced into the cylinder at any desired pressure until checked by the float and valve. At the same time a constant air-pressure is maintained in the cylinder by means of an air-compressor, the air being admitted through the pipe at

THE ELECTRIC COAL-DIGGER.

THIS is the name applied to a new mining-machine, designed and constructed by Elmer A. Sperry of Chicago, and shown in operation at the electrical exhibit of the National Electric Light Association, during its convention in Chicago recently. For five years Mr. A. L. Sweet has experimented on this project, until, with the assistance of Mr. Sperry, success has crowned their efforts.

An electrical motor is situated on the rear of the machine, and substantial gear-work transmits the power to the mechanism which operates the projectile carrying the pick.

The projectile, including the "bit," "pick," or other colter, weighs from sixty pounds up, depending upon the kind of work. The stroke is from six to eight inches, delivered with a force of

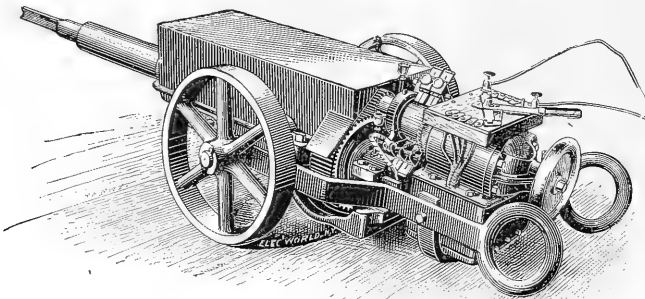

THE SPERRY ELECTRIC COAL-DIGGER.

the top of the cylinder. The hand-wheel being turned, the oil is forced up through the small pipe by the air, while a certain amount of air, proportioned to the oil, passes through the large pipe surrounding the oil-pipe. At the nozzle of the burner, where ignition takes place, the oil and air are commingled, the oil being thoroughly atomized and aerated,—circumstances most favorable to complete combustion. A two-burner cylinder is shown in Fig. 3, in which the oil inlet is at the bottom of the cylinder.

many hundred pounds, and varying from one hundred and fifty to three hundred blows per minute, according to conditions, yet always under control of the operator.

The unique feature of the machine consists in the fact, that, no matter where or at what point in the working stroke the projectile is arrested by the work or face, it is instantly picked up at that point, and returned backward to deliver another blow. For instance: if the normal stroke is six inches, and the pick strikes the

coal after travelling only four inches out of the six, the pick is not left there to push the machine and miner backward away from the work in such manner that the successive blows cannot do effective work; but the moment it has delivered its blow, and without delay, it is withdrawn for the next stroke.

The flexible electrical conductors lead from the dynamo in the engine-room down the shaft and to the machine. It is claimed that the whole design is such that danger from the current is done away with, and that the machine, wires, generator, and every part, are free from danger either to life or property.

A UNIQUE ELECTRIC POWER STATION.

THE great advantages one method of conversion of energy possesses over another when favored by circumstances is illustrated

eventually prove to be of great economic value. The culm at Scranton is now a marketable product of the mines.

An interior view of the electric power station spoken of is given in the illustration on this page. The electric current is furnished by three Edison dynamos, of 80,000 watts capacity each, wound for an electric pressure of 500 volts at a maximum. The station is most complete in all its appointments, and is furnished with electric lights, current being taken from the dynamos used to supply the motive power for the road.

The twenty cars with which the road is equipped are of the Sprague system, and ran uninterruptedly during the severe snow-storms which have visited Scranton since the road was opened. The Sprague Company and the people of Scranton, as well as the officers of the road, have reason for the satisfaction they express over the working of the road. The extraordinary economy

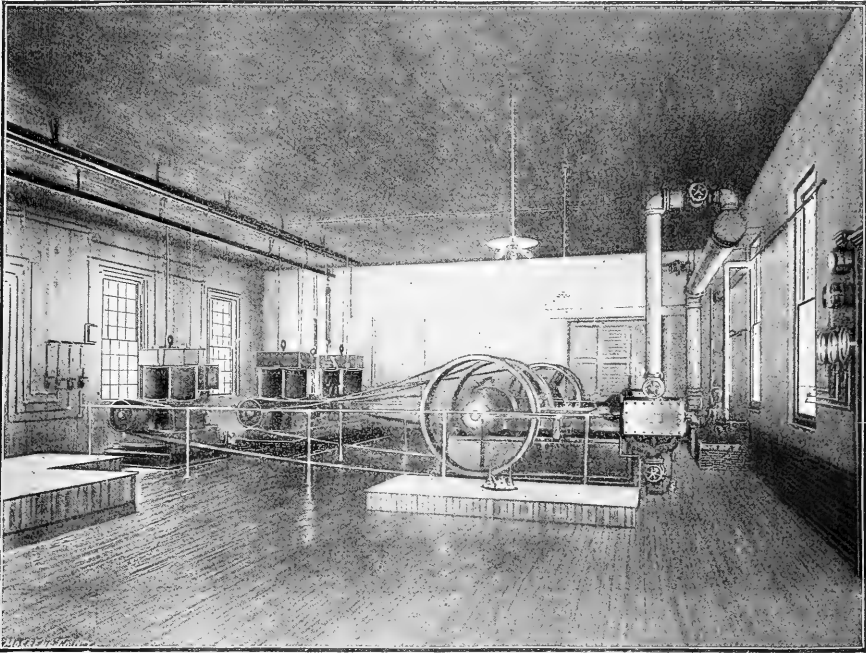

THE ELECTRIC POWER STATION, SCRANTON, PENN.

in a striking manner at the power station of the People's Electric Railway of Scranton, Penn. At a short distance from this station is an almost inexhaustible supply of "culm,"—the screenings of anthracite coal, which until recently was considered practically valueless. This culm, which costs little more than the expense of carting it to the station, is the fuel used in generating steam for the engine which drives the dynamos, the boiler-furnaces being specially adapted to the economical consumption of such fuel. As a consequence of this cheapness of fuel, it is claimed by the officers of the road, it costs less to supply the electric motive power necessary to operate the railway than it would to furnish one horse with food and attendance. When it is known that there are twenty cars in operation on this line, and that the grades are not few in number, some of them being steep, the enormous advantages given to the electric system by such exceptional favoring circumstances are apparent at a glance. The results of two months' experience on the Scranton road makes prominent not only the fact that the electric railway is a good thing in its way, but also the further fact that many things now looked upon as useless will

in working expenses, if nothing else, makes this a notable electric railway.

A COTTON FABRIC.

A COTTON fabric which has been patented in England is thus described by the *Canadian Journal of Fabrics*: "It has the appearance and soft feel of chamois leather, and, it is guaranteed, will not lose its special qualities when washed. In making the cloth, cotton yarns form the warps, these being dyed a fast color, a chrome yellow tint being preferable. They are sized and dressed in the usual manner. The weft is spun soft, and is used in the undyed state. The fabric is woven from these yarns, and is then passed several times through cylinder teasing or raising machines, whereby the surface is broken and a good ground nap is produced on one side or both sides thereof. The fabric is then 'soap' finished, to impart to it the desired appearance and soft, cold feel of chamois-leather. It is applicable for either wet or dry cleaning purposes and also as a polishing cloth, and especially suitable for underclothing and for linings of the same, and for general use as a

substitute for the chamois-leather now used for these and for analogous purposes. Being, moreover, of a woven texture, and absorbent, it is more healthy for use in garments than chamois-leather, and does not require to be perforated. Unlike leather, also, which gets stiff after washing, this improved material so produced is capable of being repeatedly washed without stiffening, and is found to retain its softness perpetually."

THE ELECTRIC RAILWAY IN ST. JOSEPH, MO.

ONE of the successful electric street-railways in the country is that in operation upon the Wyatt Park Company's line at St. Joseph, Mo., a view of which we give in this issue. This line at St. Joseph was the first one in the country, to practically demonstrate the successful operation of an electric railway in a snow-storm. In the early

A NEW FORM OF SELF INDUCTION AND REGULATING COIL.

IN the operation of electric lighting and other apparatus in which an alternating current is employed, it is frequently desirable to vary the current or electro-motive force through considerable range. With direct or continuous currents, a variable rheostat is usually employed for such purpose, and, where saving of energy is not an object, might be used also with alternating currents. But with such currents it is possible, by employing self-induction or inductive resistance in place of pure resistance, to secure such variations without much loss of energy, because the action of self-induction is really only a storing-up and giving-back of energy consequent on a displacement of phase of induced alternating impulses from the phase of impressed or supplied impulses. This is what is

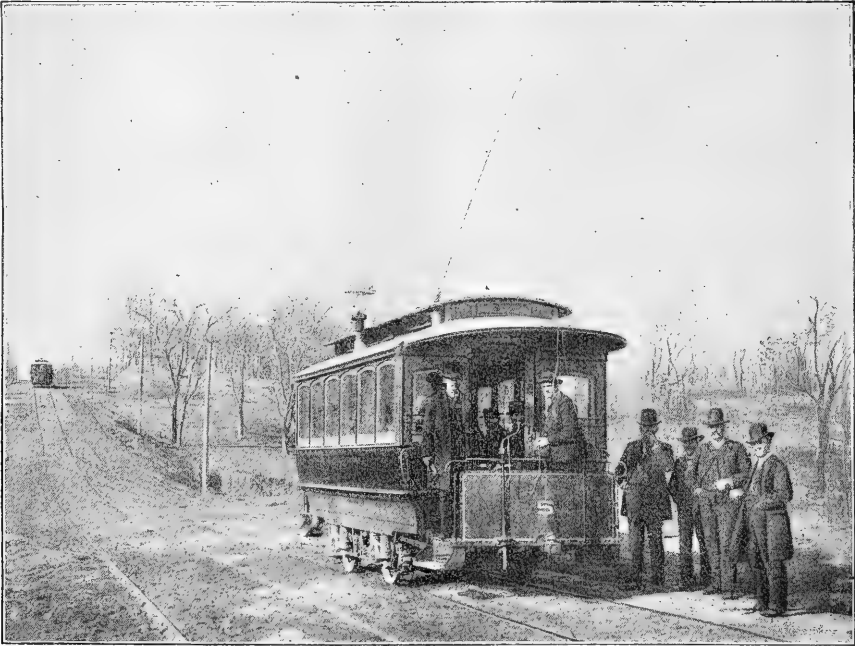

SPRAGUE ELECTRIC RAILWAY AT ST. JOSEPH, MO.

part of this winter a blizzard from the Western prairies struck St. Joseph with all its force, and covered the streets in that city to the depth of from six inches to one foot, in many places drifting badly. The telephone, telegraph, and electric-light wires were borne down by the snow in all parts of the city. In spite of this general blockade, the electric railway ran uninterrupted, and the cars ploughed their way through the heavy drifts on the line without trouble or stoppage, and without any aid from snow-ploughs.

The grades on the Wyatt Park Railway are in some points on the road as high as nine per cent; and the cars reach a speed of fifteen to eighteen miles an hour in the outside and suburban districts, reducing to a lower rate of speed when operating within the city.

St. Joseph, Mo., already has two street-railways operating by electricity on the Sprague system, and a great many manufacturing industries are kept in operation by the same power by means of stationary electric motors operated from the regular railway circuit. It is said that the two other street-railways in St. Joseph will soon be in operation upon the electric system, so that the horse shall be supplanted entirely for car service in that city.

meant by "lagging of phase," and it is an effect of self-induction or inductive resistance. Any wire capable of producing magnetism is a self-inductive resistance to such currents. A coil wound on an iron-wire core or bundle is a good example; and, if the wire bundle be a ring core or closed magnetic circuit, its effects per unit of length of wire will be enormously intensified.

Hitherto the usual plan of constructing a variable inductive resistance has been to provide a hollow coil with a movable iron-wire core in its axis, so that the centres of coil and core could be made coincident for maximum effect. This arrangement for a given effectiveness is cumbersome and unnecessarily large, inasmuch as it employs only an open magnetic circuit, and not a closed one; and, even though the core be entirely removed from the coil, the self-induction is not neutralized, because of the numerous turns of wire in the coil itself. Besides, the true resistance of the wire as such is considerable.

With a view of obviating these defects, and securing the other advantages of compactness and ease of manipulation, the apparatus to be described was devised.

It has already been applied to a number of cases of practical work, where it takes the place, for alternating-current work, of variable resistances, while it saves the energy of the circuit. It is also made self-adjusting, and can maintain a constant average of alternating current over a variable resistance, such as a series of incandescent or arc lamps connected across the terminals of a system or machine of alternating character.

If the directions of windings are made opposite, the two coils C and S , as in Fig. 3, may be connected in series or multiple arc, and the current led from a to b through them. They should in such cases be wound to have equal ampère turns capacity in magnetizing the core I . When the coils are superposed, they will neutralize one another's self-induction; but, as they are separated, the self-inductive kick or re-action will gradually increase. The variation of induction or re-action is obtained without contacts and switches, and in a smooth and gradual manner.

In the preceding figures the devices shown have been arranged to be operated manually. The same devices, however, if the parts are relatively free to move, give out, from alternating currents, a mechanical power or pressure which may repel the coils apart. To obtain a movement of coil S , or pressure tending to move it, coil C has only to be put into an alternating-current circuit. Further, this repulsive power may be utilized to make the self-induction self-adjusting, whereby there may be obtained a constant current on the circuit of a set of lamps, or the like, even though variations of voltage of current fed to them may occur. Thus, as in Fig. 4, the source, a, b , of current may be one which varies in potential, the coil C being put in series with a group of lamps, L, L . In this case the copper band or closed circuit S is pivoted freely at P , and counterpoised to a certain extent by a lever and weight, K , or other device, whose effect may be varied if need be. Sometimes a spring, Z , may be used in addition (or even alone, if of proper retractile effect), and suitable stops may be provided to limit the range of movement. Suppose that the coil S is set, and so balanced that, with a given current in coil C , it is repelled so as to about half cover the coil C (or less, if the counter-forces K, Z , are properly adjusted), and that an increase of current, due to increased potential, takes place in the circuit A . Coil C will more strongly repel circuit or band S , and it will move partly up and away, with the result of increased self-induction in coil C ; which self-induction, if the parts are suitably adjusted, will approximately restore the current strength to what it was before the change. A fall of potential corrects itself by working in the reverse direction.

The apparatus in this self-regulating or automatic form is to be used in such circuits as are represented in Fig. 5, where wires a, b , of constant or even somewhat variable potential difference, feed in multiple several separate series of lights, L, L', L' , such as incan-

It is based on the principle of the demagnetizing effect of a closed coil or circuit parallel to the coil or circuit in which the inductive resistance is to be varied; the relation of position of the two coils on a magnetizable core forming a closed magnetic circuit, or nearly so, being made variable.

In Fig. 1, I is an iron core, preferably of ring or endless form, made of wire or laminæ, suitably piled and insulated to avoid Foucault currents; C is a coil of insulated wire wound on the core, as shown; S is a closed band or coil around the ring, and arranged to be moved over the coil C by a handle, H , and pivoted at P when preferred, though it could simply be slipped along in some cases. Let, now, an alternating current of fairly constant potential be feeding the lamps L, L , from a to b , with the coil C in circuit. If the closed coil or band, S , be brought down over the coil C , very little re-action or self-induction will exist in the coil C ; and, if its resistance be low, the lights L, L , will be given their full brilliancy. If the coils S and C be now separated more and more by moving one away from the other around the ring, the self-induction of coil C progressively rises, and becomes greatest when coil S is farthest removed from it. The lights are now dimmed as far as possible, any gradation being obtained by setting the coil S in a position with respect to coil C corresponding to the desired effect. The action is smooth and very effective. If a switch, W , be placed in circuit with the coil S so as to be opened when it strikes a pin, ϕ , suitably placed, and after the coils C and S have been widely separated, the effect of coil C is further enhanced in dimming the lights or in exerting a self-induction which checks the current in any device with which the apparatus may be put in circuit.

In Fig. 2 the devices are shown placed in series, with a primary coil, P , of a transformer, whose secondary, B , feeds the lights L , or other devices, with current. A very smooth and powerful resisting effect may thus be obtained with moderate sizes of apparatus.

descent or arc lights with alternating currents. Each series, circuit, or branch requires a constant current; and to insure this, even though a light be cut out in any series, the automatic self-inductors of Fig. 4 are placed in each branch or series at C, C', C'' , where each acts, as described in connection with Fig. 4, to preserve the current strength. Of course, the group L (Fig. 4), or series L, L', L'' , may be replaced by a single light or translating device, such as an arc-lamp, without affecting the result. This has been indicated at A (Fig. 5), always assuming the potentials to be not so excessive or so feeble as to exhaust the capacity for regulation to be found in the device.

In Figs. 6 and 7 the part I'' is of iron, as shown, and carries

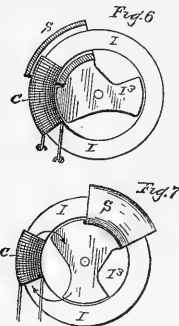
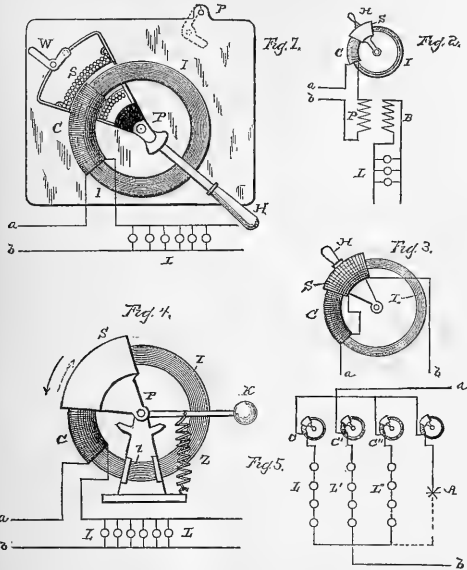

coil or band *S*. When the coils or circuits *S* and *C* are separated, as in Fig. 7, a closed iron path for the core *I*, as indicated by the arrows, is afforded the iron *I'*, operating after the manner of an armature, and comes into play to increase the effective self-induction of the coil *C*.

ELIHU THOMSON.

WEST INDIAN HURRICANES.

THE Bay of North America is that portion of the North Atlantic west of the 50th meridian, between Newfoundland and Venezuela, including the Caribbean Sea and Gulf of Mexico. In accordance

the higher latitudes. West Indian hurricanes follow this path with marked regularity; so much so, that a hurricane reported off Antigua or St. Thomas is almost sure to either sweep across the Greater Antilles into the Gulf of Mexico and strike our Gulf coast with furious intensity, or else (according to the time of the year) cross the Bahamas and follow the Gulf Stream toward Hatteras and the Grand Banks. With the telegraphic facilities that already exist, it is therefore possible to give from twenty-four hours to ten days' warning of the approach of one of these terrific tropical cyclones, — warning that might often result in the saving of more property ashore and at sea in a single storm (not to speak of the

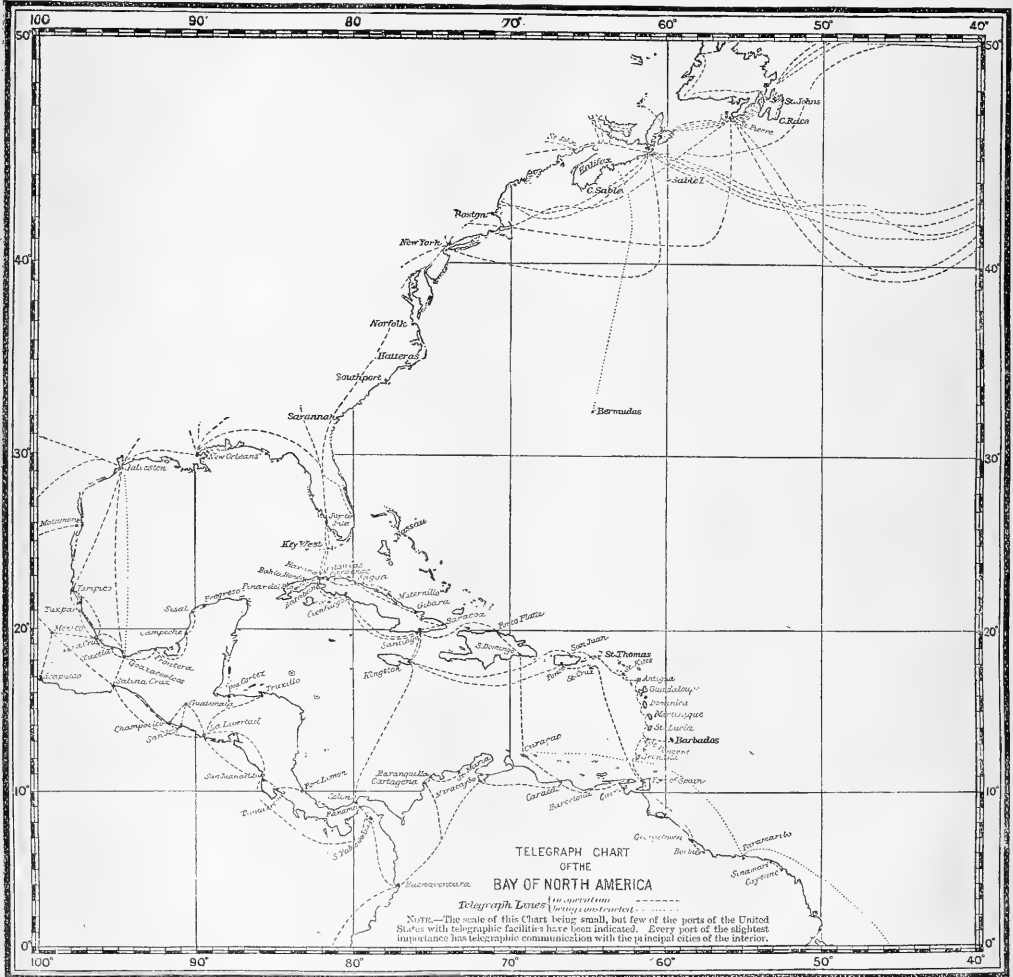

with the policy followed hitherto by the United States Hydrographic Office, of calling attention to matters of special importance to navigators, on "The Monthly Atlantic Pilot Chart," a telegraphic chart, which we here reproduce, has been prepared to illustrate the admirable facilities that are available for the establishment of a more complete system of telegraphic weather forecasts, for the benefit of the commerce of various nations frequenting this great bay, as well as of the inhabitants of its shores and islands. The general movement of storms over this area is westward in the tropics, then northward into the temperate zone, and eastward in

lives endangered) than would suffice to pay for the cost of a well-equipped weather service for several years. Moreover, it is well known that the movement of an area of low barometer is controlled to a very large extent by areas of high barometer adjacent to it, especially in advance (even though a thousand miles away), and many noticeable instances might be referred to; the hurricane in the Gulf in August, 1886, for example; the March blizzard of last year; and the severe cyclone off the coast last November. The wider the field of observation, therefore, the better the forecast; and the completion of the cable to Bermuda will be invaluable in

company's affairs by the government, within the past year, that was made the most serious charge in the inspector's report. It is too soon to say what the outcome of all this will be, though it seems highly probable that the company's charter will be modified, and its administration re-organized.

Mexico was a long time in cutting loose from the old Spanish ideas of national exclusiveness. Various slight changes were made from time to time in the laws of the colonial period, aimed at foreigners; but it was not until 1842 that foreigners were allowed to own real estate in Mexico, and even then they were hedged about with many restrictions, such as the prohibition of holding more than two pieces of property in the same political department. Yet the country has long been desirous of enjoying the benefits of immigration. Efforts to secure them have been made along two lines. Many contracts have been made for the survey and opening of unoccupied lands, payment for the work being partly made in grants of lands, with the hope of inducing colonization to take them up; and the government has directly undertaken to plant and support colonies. Both methods have resulted, in the words of Minister Pacheco in a special report on the subject made last year, "only in bitter disappointment and the loss of large sums to the national treasury."

Particularly costly and disastrous were the attempts at colonization made by President Gonzales during the term of his administration. Italian immigration was the thing he aimed at. Large bodies of immigrants were induced to come from Italy; many Italians went to Mexico from New York, the Mexican consuls getting so much a head for every one shipped, and were located on government lands selected for the purpose. But the plan was wretchedly conceived, and came to nothing except great suffering to the immigrants, and immense expenditures to the treasury. The minister of public works, in the report alluded to, referring to these experiments, says that the outlay upon them amounted to upward of \$1,500,000, and that there is practically nothing to show for it all to-day.

It would be easy to assign reasons for this long series of failures. The unsettled condition of the government, bad systems of taxation, poor methods of farming, and lack of means of transportation, have undoubtedly had much to do with the unsatisfactory results; but perhaps a deeper cause than any other is the lack of demand for small holdings of land. The system of great ranches seems to be the only one possible or profitable in the case of the land at present unoccupied. Small farming can be carried on successfully only in the neighborhood of cities, and there all the available land has long since found owners. A farm of a few acres in a remote location is practically of no value to its owner. This was pretty thoroughly shown in the experiments tried by Juarez. He had the French communal system made obligatory in certain localities, in the hope of raising up a generation of small proprietors; but in a very short time it was found that all the owners of small holdings had sold out, so that the land was again in the hands of one or two ranchmen. That there is really no demand for small properties anywhere along the American frontier, is also shown in the ridiculously low prices set upon government lands in the border States. According to a presidential decree of last December, the price of public lands in those localities for 1889 and 1890 was fixed at an average of about fifty cents the hectare, or say twenty-five cents an acre. With thousands of acres for sale at such prices, and no bidders, the difficulties in the way of Mexican colonization are of themselves apparent.

Notwithstanding the humerous failures at colonizing portions of Mexico, we cannot but consider the prospects of a great part of the area owned by the International Company as favorable. The rapid progress of Southern California cannot fail to have a beneficial influence upon the adjoining region, which is very similar to it in character. Formerly the whole of the peninsula was considered a desert; but it has been shown that in its northern portion there is an abundant supply of water. This is derived from the great chain of mountains indicated on the accompanying sketch-map, the highest parts of which are said to be more than ten thousand feet in height. Mr. C. Nordhoff, in his pamphlet "Peninsula California," quotes the following description of this mountain-range from a report of its explorer, Col. D. K. Allen: "This great mountain region

lies about one hundred miles south-east of Ensenada, seventy-five miles east of San Quintin, and from thirty to thirty-five miles west of the Gulf of California. The range is about one hundred and ten miles in length, and from fifteen to thirty in width. Water is abundant everywhere, and only has to be husbanded in order to furnish a great supply for all the lands on the north end of the peninsula. These streams can be easily and cheaply dammed, and all of the pine can be put into them and floated down to the heads of the valleys. This can be done with the San Rafael, which is a grand stream with five large branches, draining nearly all of the north end of San Pedro; also with the San Domingo, which drains the western side of the mountains; and the logs or timber can be taken out at the upper end of San Rafael valley near Colnett, or at the upper end of San Quintin valley near San Ramon. Either water route is perfectly feasible."

The peninsula is undoubtedly rich in minerals, but its great development in this direction can come only with a denser population. Gold, silver, and copper are at present worked by various companies. With these possibilities of irrigation, with a healthful climate favorable to the carrying-on of valuable cultures, with good pastures in the mountainous region and an ample supply of timber, and with rich mineral deposits, there can be no doubt that the country will be developed as soon as its political state appears sufficiently stable.

HEALTH MATTERS.

The Use of Tobacco.

IN a communication to the *New York Medical Record*, Dr. F. H. Bosworth discusses the effect of the use of tobacco on the health. He says that the Anglo-Saxon races have been smoking and chewing now for nearly four hundred years. They contracted the habit from a race which, as far as history and tradition teach us, were remarkable for their vigor of body and mind as well, and, as far as we know, were an unusually long-lived people. In the time that we have been using the weed there is no evidence to show that the race has in any way deteriorated, but, on the contrary, it is abundantly shown that the average duration of life has increased nearly fifty per cent. There is no evidence to show that in this time the race has been more subject to disease, but rather that they are less so. There is no evidence to show that the race has lost any thing in its intellectual activity, but, on the contrary, it has been a time of most marvellous fecundity in all that is great in literature.

He gives the following analysis of tobacco, that of Passelt and Reinmann, which is accepted as correct by authorities:—

Analysis of the Leaf.

Nicotine.....	0.060
Volatile oil.....	0.110
Bitter extractive matter.....	2.870
Gum and malate of lime.....	1.740
Chlorophyll.....	0.267
Albumen and gluten.....	1.308
Malic acid.....	0.510
Salts of pot. ammonia, etc.....	0.734
Silica.....	0.088
Water.....	88.280
	100.00

Leaving out from this analysis the volatile oil, extractive matter, albumen, gluten, and chlorophyll, and negative and inert matter, and we have left a substance containing 1 part of nicotine, 4 parts of salts of lime, ammonia, etc., with 88 parts of water in 100. The percentage of nicotine in various kinds of tobacco varies; Havana tobacco containing but two per cent of this poisonous element, while Virginia tobacco contains about seven per cent, according to some analyses. The moral of this is that we should always smoke the choicest brands of Havana cigars. In smoking, the ammonia salt may become the source of considerable discomfort in the burning and smarting tongue which results from excessive and continuous practice of the habit; of course, in chewing, this action is not noticeable. We thus are reduced to the action of nicotine for the possible deleterious influence of the plant. This element, as before stated, is present in varying proportions in the tobacco-leaf;

according to some writers, from one to seven per cent. It is a clear and colorless fluid, highly volatile, and of an extremely pungent, disagreeable odor, and strong, burning taste. It is rapidly absorbed into the fluids of the body, and is one of the most deadly poisons known. It is rendered volatile by burning the leaf, and is present in the smoke of the tobacco. It is generally accepted that the volatilized nicotine in the tobacco-smoke is more actively absorbed than is the case when the leaf is chewed; but in either case the nicotine absorption is the essential element in the production of all of the evils which can be charged to the habit. Nicotine acts on the heart, nervous system, stomach, and upper air-passages. The prominent symptoms which may be caused by nicotine, with reference to the heart, are intermission and palpitation; that is, it produces certain functional disturbances of the heart, which, for the time, may be the source of more or less discomfort to the patient; but the important point is, does this condition ever lead to one of organic lesion?

Dr. Bosworth thinks that the action of nicotine on the nervous system may be summed up by the statement that it produces disturbance of brain, giddiness, muscular tremors with exhaustion, sleeplessness, and depression of spirits. He does not advocate the use of tobacco, but asks, "Are we not often liable to fall into a mistake in universally condemning its use without sufficient grounds, and is it not better when our advice, as physicians, is asked, in this respect, to base our answers entirely on the evidences of the effect of the drug upon each individual patient, and, furthermore, to recognize the fact that this effect is shown by well-marked and easily recognized subjective symptoms?" I have frequently, when asked this question, "Does smoking hurt me?" frankly said to my patients, "You know better than I do; no man uses tobacco to his harm without being fully conscious of it." As regards its effect on the diseases of the upper air-passages, in a practice of twenty years largely devoted to treatment of these affections, I recall but exceedingly few cases wherein I have found it necessary to interdict the use of tobacco as injuriously affecting in any way these passages, or as interfering with the success of treatment."

The object of this paper is not a plea for the use of tobacco, but simply to suggest whether we had not best abandon the idea that it is a drug whose use is pernicious in every way to body, mind, and morals, and rather to take the view that it is one of God's good gifts to man, — a "virtuoso herb, divine, rare, superexcellant tobacco" when properly used, but when taken "as tinkers do ale, 'tis hellish, devilish, and damned tobacco."

Diphtheria.

THE subject of diphtheria is now attracting unusual attention on the part of boards of health and physicians throughout the country. The Kings County Medical Association has spent the entire winter in its discussion, and the medical profession of Boston has recently devoted a great deal of time and thought to its causation and methods of prevention. In the present number we give a *résumé* of the discussions and reports as they have appeared in the meetings of the Suffolk District Medical Society. There is no question more important for sanitarians to consider than the means of preventing the spread of this dread malady. From a recent report we find that in a single week its victims were as follows: in Brooklyn, 21; New York, 47; Philadelphia, 6; St. Louis, 11; Chicago, 26; Boston, 11; Cincinnati, 10; Paris, France, 37; and London, 25. It has become a permanent resident in almost every city of the world. In the treatment of this disease, but little progress has been made. If its ravages are ever to be lessened, it must be done through its prevention.

Dr. J. H. McCollom has presented to the Suffolk District Medical Society some observations on diphtheria in Boston during the year 1888. Of this disease, 1,411 cases occurred during that period, of which 470, or 33.3 per cent were fatal. After a thorough study of the facts, he comes to the conclusion that the theory advanced by some recent observers, that diphtheria prevails more extensively in the vicinity of old water-courses and dry river-beds, certainly is not tenable so far as that district is concerned. Neither does the theory of defective drainage explain the prevalence of the disease: for, in the first instance, there are no old water-courses or dry river-beds in that locality; and, in the second place, the drainage the

past year, when there has been a large number of cases, has been much better than in 1887, when there were very few cases. Contagion is, therefore, the only possible explanation for this condition. From the opinion of the observers cited, from the fact that the disease has invaded districts where the sanitary conditions were remarkably good, from the fact that out of 1,117 examinations in only 596 instances was defective drainage found, from the fact that the source of contagion could only be traced in 276 instances out of 1,383 reported cases, and from the fact that there has been a marked increase in the disease when children were brought together in large numbers, it would seem that the general extension of the disease must be attributed to contagion; not from the recognized, but from the unknown and mild cases.

At a recent meeting of the same society a committee was appointed to confer with the board of health as to the necessity and feasibility of further measures to limit the spread of diphtheria. The committee, at the last meeting, reported that under the existing laws the board has authority to isolate cases of diphtheria which are reported to them, or in any way fall under their observation, but that this power is not in all cases available, for lack of proper financial means. They may, for instance, send cases to the City Hospital or other institutions willing to receive them, and having proper facilities for isolation and treatment; but, once there, the authority of the board ceases, and they cannot prevent the removal of the case at any time by its parents, guardians, or friends, nor can the hospital authorities compel their patients to remain. The board can also compel proper disinfection where cases are made known to them. They can enforce the legal penalties for non-report on the part of physicians, but are here met with the well-known fact that in many cases it is impossible for the most skilful diagnostician to differentiate for the first twenty-four or even forty-eight hours between non-contagious, tonsillar, pharyngeal, and nasal diseases and genuine diphtheria. There is a belief among those not well informed, of the community, that this disease is neither infectious nor contagious, and may therefore be safely and more conveniently treated in their own houses. It is believed by the committee that very much may be done in this direction through the influence of this society by creating more correct views in the public at large as to the contagiousness of the disease, the absolute necessity of isolation, and a more earnest co-operation with the board of health. The public has now become so fully enlightened as to the dangers from small-pox, that the board meet with comparatively little opposition in the most stringent and arbitrary enforcement of isolation, so far as that disease is concerned; and it is believed that the same enlightenment with regard to diphtheria would do very much towards diminishing its spread by inducing a more ready compliance with the necessary measures of isolation and disinfection. The committee recommends that this society, both collectively and individually, should foster, so far as they can, a proper sentiment in the community as to the contagiousness of this disease, and more especially should encourage its earliest possible recognition and report to the board of health in each individual case. By these methods a public sentiment will sooner or later be created, justifying and requiring from the proper authorities a suitable separate hospital for the treatment of infectious and contagious diseases, such, for instance, as is required by law in England, with ample means for its support, and over which there shall be as absolute authority as already exists over the hospital for small-pox. In the absence of these necessary facilities for thorough isolation, it is impossible to exercise an efficient control over the various dangerous diseases that from time to time become epidemics in our cities, or which have gained a permanent foothold in Boston.

The Boston Board of Health has issued a circular for the purpose of more widely extending the knowledge of a few well-attested facts concerning diphtheria, and reminding all persons that greater care should be exercised to prevent the spread of this much-dreaded disease. The circular states that diphtheria is contagious and infectious, and may be easily communicated, either directly or indirectly, from person to person. It may be conveyed directly in the act of kissing, coughing, spitting, sneezing; or indirectly by infected articles used, as towels, napkins, handkerchiefs, etc. The poison clings with great tenacity to rooms, houses, articles of furni-

ture and clothing, and may occasion the disease even after the lapse of months. Diphtheria attacks all classes, at all ages, and at all seasons of the year. By preference it attacks children and those who are debilitated from exposure to filth, dampness, or foul air from whatever source. When a case of diphtheria occurs in any family, the sick person should, if possible, be taken to a hospital; otherwise he should be placed in an upper room apart from the inmates of the house, and should be nursed, as far as possible, by one person only. The sick-chamber should be well warmed, exposed to sunlight, and well aired; its furniture should be such as will permit of cleansing without injury; and all extra articles, such as window and table drapery, woollen carpets, upholstered furniture, and all hangings, should be removed from the room during the sickness. The physician and nurse, as a rule, should be the only persons admitted to the room.

Visitors to the infected house should be warned of the presence of a dangerous disease therein, and children especially should not be admitted. All clothing removed from the patient or the bed should be at once placed in a solution of corrosive sublimate—two drams to the gallon of water, in a wooden vessel—by the nurse before being carried through the house or handled by any other person. They may be soaked in this fluid for a convenient time, and then boiled for one hour. It is better not to use handkerchiefs for cleansing the nostrils and mouth of the patient, but rather soft rags, which should be immediately thereafter burned. All vessels for receiving the discharges of the patients should constantly contain some of the disinfecting liquid. Water-closets and privies in the house should be disinfected daily with a solution of fresh chloride of lime (half a pound to the gallon of water). Every kind and source of filth in and around the house should be thoroughly removed, and disinfectants freely used. Cleanliness tends both to prevent and mitigate the disease. Drains should be put in perfect order and ventilated by a four-inch straight pipe extended above the highest point of the roof of the house in every instance, terminating at a distance from any chimney or other ventilator. Children in the family should not attend school or mingle with other children until the patient has wholly recovered and all infected articles have been disinfected, and these facts certified by a responsible physician.

On the recovery, removal, or death of the patient, the most thorough disinfection should follow. Close up all apertures in the room tightly; hang up, unfolded, all articles of bedding, clothing, etc.; remove all mattress-covers for the free exposure of their contents; place in an iron pan four pounds of brimstone for each thousand cubic feet of space in the room; place the pan on two bricks or an iron rest in a tub containing water; pour a little alcohol on the brimstone, ignite it with a match, and leave the room closed tightly and guarded for not less than ten hours. The fumes of burning brimstone are dangerous to breathe, and will kill animals and plants. After fumigating has been done, the room and every thing in it should be thoroughly aired. The walls and ceilings should be brushed, and the floors and other wood-work washed with water containing two drams of corrosive sublimate to the gallon of water, and all vessels and utensils used in the room should be thoroughly washed with the same solution. All wash-bowls, water-closets, sinks, and slop-hoppers should be washed with a solution of chloride of lime (one half-pound to the gallon of water). When death occurs, the body should be immediately placed in the coffin, wrapped in a sheet saturated with a solution of corrosive sublimate (two drams to the gallon of water), and the coffin tightly and finally closed. No public funeral should ever take place at the house where the patient died, or elsewhere, unless the coffin remains hermetically sealed. Corrosive sublimate is a poison.

NORMAL MICROBES IN THE HUMAN STOMACH.—M. Abeloos recently communicated to the Académie des Sciences the results of an investigation of the microbes of his own stomach. He succeeded in obtaining and studying no less than sixteen separate and distinct species. Of this number, seven have already been described, while nine appear to be new ones. The known ones are *Sarcina ventriculi*, *Bacillus pyocyaneus*, *Bacterium lactis aërogenes*, *B. subtilis*, *B. mycoïdes*, *B. amylobacter*, and *Vibrio rugula*. One of the unknown species was a coccus; the others were bacilli. Especial interest attaches to the function which Abeloos believes

these micro-organisms perform in connection with digestion. Thus he found that 10 attack albumen, 12 fibrine, 9 gluten, 10 cause the more or less complete transformation of lactose into lactic acid, and 13 form variable quantities of glucose from starch.

ANATOMICAL AND PHYSIOLOGICAL MEMORANDA.—The following anatomical and physiological memoranda, which we copy from the *New York Medical Record*, will be of interest to our readers, and serve a useful purpose as a matter of reference: "In each respiration an adult inhales one pint of air. Man respire sixteen to twenty times a minute, or twenty thousand times a day; a child, twenty-five to thirty-five times a minute. While standing, the adult respiration is twenty-two; while lying, thirteen. The superficial surface of the lungs, i.e., of their alveolar spaces, is two hundred square yards. The amount of air inspired in twenty-four hours is ten thousand litres (about ten thousand quarts). The amount of oxygen absorbed in twenty-four hours is five hundred litres (744 grams); and the amount of carbonic-acid gas expired in the same time, four hundred litres (911.5 grams). Two-thirds of the oxygen absorbed in twenty-four hours is absorbed during the night-hours from 6 P.M. to 6 A.M. Three-fifths of the total CO₂ is thrown off in the day-time. The pulmonary surface gives off one hundred and fifty grams of water daily in the state of vapor. An adult must have at least three hundred and sixty litres of air an hour. The heart sends through the lungs eight hundred litres of blood hourly, and twenty thousand litres, or five thousand gallons, daily. The duration of inspiration is five-twelfths, of expiration seven-twelfths, of the whole respiratory act. During sleep, inspiration occupies ten-twelfths of the respiratory period."

LIME-BURNERS FREE FROM CONSUMPTION.—It is said that lime-burners are free from consumption. Halter has observed this in the Lengerich kilns. The temperature of the air inhaled at these kilns is 105° F. to 158° F., and to this Halter attributes the immunity of the lime-workers more than to any thing else. He recommends for the treatment of consumption the inhalation of dry air heated to from 248° F. to 374° F. His theory is that the development of the bacilli is prevented by this high temperature.

AUSTRALIAN RABBIT-PEST.—The experiment of introducing the virus of chicken cholera into Australia, with the object of exterminating the rabbits which have become such a plague in that country, has proved a failure.

RHEUMATISM.—Dr. Terc contributes to the *Wiener Medicinische Presse* a novel method of curing rheumatism. He observed, that, when rheumatic persons were stung by bees, the swelling which usually follows such stings was very slow in appearing, and, if the persons were stung repeatedly, it did not appear at all; the result of such continued stinging being to cure the rheumatism, which showed no tendency to recur. He followed out this idea in the cases of 173 persons, 39,000 stings being required. Both acute and chronic cases were cured by this treatment.

ELECTRICAL NEWS.

The Discharge of a Leyden Jar.

DURING the past year, Professor O. J. Lodge has experimented and written a great deal on the subject of lightning-conductors. He has taken up the subject of electrical discharges, and has shown that many of our notions on the subject require modification. But the experiments he has made have necessarily on a small scale, and, in applying his results directly to the problem of protection from lightning-discharges, he may be greatly in error. Still he has called attention to and stimulated inquiry on a subject of vital importance, and his work is already bearing fruit in the investigations begun by a number of other workers.

On March 8, Professor Lodge delivered a lecture at the Royal Institution of Great Britain, on the discharge of a Leyden jar. When such a jar is charged with electricity, and then the two coatings are discharged by connecting them by a short, thick wire, the result is not a single current of electricity along the wire in one direction, but the current passes back and forth, its intensity diminishing until it finally dies away and the jar is fully discharged.

This oscillation of the current was first observed by Joseph Henry, in 1842. He found that when the wire joining the two coatings of the jar was bent into a helix, and a needle placed inside, the magnetization of the needle due to the discharge-current was not always in the right direction. Henry stated that "the phenomenon requires us to admit the existence of a principal discharge in one direction, and then several reflex actions backward and forward, each more feeble than the preceding, until equilibrium is obtained." Later, Thomson worked out a mathematical theory of the subject, which agreed with Henry's observations; and further experiments have substantiated the results.

Professor Lodge showed experimentally, but on a small scale, a case of the resonance of two Leyden-jar discharges, by causing sparks in one circuit by the discharge of a jar in a neighboring one. Another interesting experiment was the rendering audible of a Leyden-jar discharge as a musical note. The period of the oscillation in an ordinary discharge is many million vibrations a second. But this can be reduced in two ways, — by adding to the capacity of the circuit; or by increasing its self-induction, as one would increase the flexibility of a spring, and then load it in order to increase its period. On adding more jars, and on increasing the self-induction of the circuit by putting in a coil of wire, the period was reduced until a shrill whistle resulted from the discharge; on adding another coil, the one lowered again until the pitch was about that of the highest note of a piano; another coil brought it down to the octave above the middle C. The noise of the spark which is ordinarily heard is due to the sudden heating of the air. If the heat is oscillatory, the sound will be oscillatory too; and, by reducing the period of the electric oscillation, we bring the sound within the limit of audibility. On analyzing the spark that produced the lowest note, by means of a rotating mirror, a coarsely serrated band was seen. Another interesting experiment was tried with the jar discharge. If a polarized ray of light be passed through a piece of heavy glass around which a current is passed, the plane of polarization is rotated. Instead of a steady current, Professor Lodge used the oscillatory current from the jar; and a similar effect was obtained, even when the period was less than one seventy-thousandth of a second.

In concluding, Professor Lodge said, "The present is an epoch of astonishing activity in physical science. Progress is a thing of months and weeks, almost of days. The long line of isolated ripples of past discovery seem blending into a mighty wave, on the crest of which one begins to discern some oncoming magnificent generalization. The suspense is becoming feverish, at times almost painful. One feels like a boy who has been long strumming on the silent keyboard of a deserted organ, into the chest of which an unseen power begins to blow a vivifying breath. Astonished, he now finds that the touch of a finger elicits a responsive note; and he hesitates, half delighted, half affrighted, lest he be deafened by the chords which it would seem he can now summon forth almost at will."

A NEW ALLOY. — A new alloy has been made by Herr Reith of Bockenheim, Germany, which is said practically to resist the attack of most acid and alkaline solutions. Its composition is as follows: copper, 15 parts; tin, 2.34 parts; lead, 1.82 parts; antimony, 1 part. The alloy is therefore a bronze with the addition of lead and antimony. The inventor claims that it can be very advantageously used in the laboratory to replace vessels or fittings of ebontite, vulcanite, or porcelain.

A SERIES ELECTRIC TRAMWAY IN ENGLAND. — There has recently been tried, near the Northfleet Station of the South-Eastern Railway in England, an experiment on a system of electric traction, which, in its practical realization, has been imported from the United States. Indeed, it is curious that while the English technical papers claim with some pride that the work is a "distinctly English invention, due to the late Professor Jenkin and Professors Ayrton and Perry," yet the invention apparently lay dormant until it was practically worked out by two Americans, — Short and Nesmith, — applied on an extended scale in the United States, and finally introduced into England by the corporation controlling their patents. The track used for the trial seems to be considered a specially difficult one, since it has on it a three-

per-cent grade four hundred yards long; but if we compare it with the average line in this country, where eight and even ten per cent grades are the rule rather than the exception, it would seem a very easy trial. The car was propelled by a single motor, sleeved to the axle and flexibly suspended, according to the system introduced by Sprague. Current was supplied from a conductor carried in a conduit. The novel feature of the system lies in the fact that the cars are worked in "series" instead of in "parallel." This necessitates the interposition of the motors into the main line; and to effect this a special device is needed. In the main line, in the centre of the conduit, are a number of contacts made by two plates normally held together by springs. If these plates were pulled apart, the main circuit would be broken, unless at the same time some conducting circuit is joined across them. Attached to the car, and travelling in the conduit, is a long "arrow." There are metallic strips on either side of the "arrow," and between these strips is joined the circuit of the motor. As the car moves along, the "arrow" passes between the contact-plates, forcing them apart, and thereby introducing the motor into the main circuit. On passing through a distance equal to the length of the "arrow," another set of contact-plates is forced apart, while the set which is left closes, thus keeping the circuit intact. On the trial the system worked well, and every one was well satisfied, as is usually the case at an exhibition of a new system. It should be remembered, however, that in this country the system has not been uniformly successful. At Denver a great deal of trouble was experienced, to the detriment of electric traction in that section of the country, and the system is not being rapidly introduced. The large number of contacts required, the possibility of some of them failing, the great danger of burning out the motors, with other possible objections, tend to make an unfavorable comparison with systems of greater simplicity.

THE PRICE OF COPPER. — The collapse of the copper syndicate should have an excellent effect on the extension of electric lighting and power distribution. The high price that has ruled in the last year has been very unfavorable to electric-light people, especially those using the low-tension system of distribution. It is to be hoped, however, that the change in the cost of copper will not bring up again the fierce discussions as to the relative merits of high and low potential distributions which ruled about a year ago. We can expect, however, that this year will see more than double the amount of plant installed than did last year.

NOTES AND NEWS.

SEVERAL large textile manufacturers of Paterson and other manufacturing centres are reported by *Bradstreet's* to be inaugurating a movement for the founding of a textile technical school. The object of the movement is threefold, — to elevate the character and improve the style of the American fabrics, to render the domestic manufacturers independent of European art and skill in the production of high-grade goods, and to secure independence of trades-unions. Negotiations are reported to have already been opened with qualified teachers from abroad to assume charge.

— As summer approaches, and so many of our readers are considering the possibility of spending some of their vacation time in Europe, it may be well for them to investigate the merits of the Cheque Bank as a custodian of their funds while travelling. This institution was established seventeen years ago in London, for the convenience of the travelling public, and numbers among its trustees some well-known men. The bank aims to furnish the traveller with an immediately available security equal in value to a Bank of England note, only safer to carry. Letters of credit are done away with, while upwards of two thousand banks and bankers throughout Europe are now cashing the checks issued by the Cheque Bank. The British Government accepts them in settlement of customs charges, and railroad companies frequently accept them in payment of fares, as do also hotels and store-keepers in some cases. The bank issues check-books, each containing ten checks, which can be drawn for any amount the purchaser may desire. A branch office has recently been opened in New York under the management of Messrs. E. J. Mathews & Co., at No. 2 Wall Street.

SCIENCE:

A WEEKLY NEWSPAPER OF ALL THE ARTS AND SCIENCES.

PUBLISHED BY

N. D. C. HODGES,

47 LAFAYETTE PLACE, NEW YORK.

Subscriptions.—United States and Canada.....\$3.50 a year.
Great Britain and Europe.....4.50 a year.

Science Club-rates for the United States and Canada (in one remittance):

1 subscription 1 year.....	\$ 3.50
2 " " 1 year.....	6.00
3 " " 1 year.....	8.00
4 " " 1 year.....	10.00

Communications will be welcomed from any quarter. Rejected manuscripts will be returned to the authors only when the requisite amount of postage accompanies the manuscript. Whatever is intended for insertion must be authenticated by the name and address of the writer; not necessarily for publication, but as a guaranty of good faith. We do not hold ourselves responsible for any view or opinions expressed in the communications of our correspondents.

VOL. XIII. NEW YORK, APRIL 5, 1889. No. 322.

CONTENTS:

CRUDE PETROLEUM AS A FUEL.....	249	ELECTRICAL NEWS.	
THE ELECTRIC COAL-DIGGER.....	250	The Discharge of a Leyden Jar....	258
A UNIQUE ELECTRIC POWER STATION	251	A New Alloy.....	259
A COTTON FABRIC.....	251	A Series Electric Tramway in Eng- land.....	259
THE ELECTRIC RAILWAY IN ST. JO- SEPH, MO.....	252	The Price of Copper.....	259
A NEW FORM OF SELF INDUCTION AND REGULATING COIL.....	252	NOTES AND NEWS.....	259
<i>Elihu Thomson</i>	252	EDITORIAL.....	260
WEST INDIAN HURRICANES.....	254	The Decline of Book-Buying.....	260
COLONIZATION OF LOWER CALIFORNIA	255	ALUMINIUM AND ITS MANUFACTURE BY THE DEVILLE-CASTNER PRO- CESS.....	260
HEALTH MATTERS.		BOOK-REVIEWS.	
The Use of Tobacco.....	256	Suggestive Therapeutics.....	265
Diphtheria.....	257	Natural Inheritance.....	266
Normal Microbes in the Human Stomach.....	258	AMONG THE PUBLISHERS.....	267
Anatomical and Physiological Mem- oranda.....	258	LETTERS TO THE EDITOR.	
Lime-Burners Free from Consump- tion.....	258	The Robinson Anemometer.....	
Australian Rabbit-Pest.....	258	<i>H. A. Hazen</i>	268
Rheumatism.....	258	An Earthquake in Pennsylvania.....	
		<i>J. E. Kershner</i>	268
		Shall We Teach Geology?.....	
		<i>E. A. Strong</i>	269
		Curves of Literary Style.....	<i>M.</i> 269

THE ISSUE OF THE *Publishers' Weekly* for March 30 contains the spring announcements of American publishing-houses. This list shows comparatively few books of importance,—a fact very likely due to the tendency, on the part of the trade, to put off their best things and postpone their best efforts until fall. This has come about through the custom, at present prevailing in this country, of buying books only through one or two months in the year, which has led to a considerable demoralization of the trade of book-making. There are now in America sixty millions of people, using one language, the most of them able to read, and, on the average, more able to buy books than the people of any other country. The trade in reading-matter is certainly enormous, but it is largely confined to newspapers and periodicals; the newspapers especially growing bigger and bigger, until their Sunday issues supply for three or four cents more than a day's reading. For the time being they monopolize a great part of the reading-time of the week, and lessen in this manner the time available for books. Yet, taking all this into consideration, and remembering that in the thirty years since 1859 our population has more than doubled, and the proportion of illiteracy has decreased, there ought to be a great demand still left for books. There are certainly a large number of cheap editions supplied through the dry-goods dealers and similar channels of distribution; but it remains that the book-market is not of as high a class as was that of a generation ago. Just before

the war several of the existing houses and the predecessors of existing houses in New York, Boston, and Philadelphia, were almost at the culmination of their prosperity; and, besides these, there were a number of other publishing-houses of note or respectability whose names are honorable in the history of literature. It would be difficult to find now any publisher who would undertake at his own risk the issue of the many standard series of books which were so creditable to American book-production of thirty years back.

Publishers find in the present state of American literature little to encourage them; authors find in the present state of American literature little to encourage them. The largest houses are unwilling to take the risks which a generation ago their fathers in the business would have taken. The retailers of books have certainly not increased in number, and have apparently decreased. Take, for instance, the city of Salem, Mass., the home of Hawthorne, Prescott, Bowditch, and of many others who have made American literature famous,—a place whence some of the noted publishers in the American trade found their way to Boston and other places, a city of great intellectual activity. In old days it was well supplied with retail stores, some of which grew to be publishing-houses. The book-trade of Salem has not been displaced by a free public library. It is only within the last year or two that such an institution has been started. Yet only one book-store of any importance remains in Salem, and that is largely devoted to the sale of wall-papers, etc., and expects rather to take orders than to carry any considerable amount of standard books in stock. The live book-trade has gone almost entirely into the hands of an enterprising dry-goods house, who are members of the Syndicate Trading Company, and who handle at Christmas time and throughout the year a considerable quantity of books, but could scarcely be relied upon to perform the functions of the old-fashioned book-store, with its supply of standards on the shelves, tempting a customer to increase his library with books that are books. It can scarcely be said that the retail trade has gone to Boston, for the trade of Boston is not so wonderfully larger than it was in old times; and this state of things is more or less true throughout the country. Book-selling and book-buying have both suffered a decadence in quality as well as in quantity, except in the case of books of exceptional popularity. The size of editions is scarcely larger, if as large, as in the days when we had not a third of our present reading population.

ALUMINIUM AND ITS MANUFACTURE BY THE DEVILLE-CASTNER PROCESS.

ALUMINIUM was shown to be a distinct substance in 1754 by Marggraff. It may be ranked among the noble metals, because it does not tarnish, even when exposed to damp and very impure atmospheres; and until lately it was almost a precious metal, the price ranging as high as 60 shillings per pound. Indeed, even now, absolutely pure aluminium is scarcely to be obtained, the metal used in the arts being contaminated with from two to five per cent of iron, silicon, and other substances. The chemical symbol of aluminium is Al: its atomic weight is 27.4. Aluminium is very widely diffused over the earth. Its silicate forms the chief constituent of clays, and enters into the composition of a vast number of minerals, especially of felspars. Its fluoride, united with that of sodium, forms cryolite. A ferruginous hydrate is known as bauxite, and forms probably the most convenient ore from which to extract the metal.

The method now generally adopted in preparing aluminium was discovered early in this century by the eminent French chemist, Henri Saint-Claire Deville, and consists in reducing the double chloride of aluminium and sodium ($2\text{NaClAl}_2\text{Cl}_6$) by means of metallic sodium at a high temperature. The manufacture, therefore, resolves itself naturally into two parallel processes; the one comprising the preparation of the double chloride, and the other the production of metallic sodium. As sodium to the extent of nearly three times the weight of aluminium is required in the re-

duction of the latter metal, it will be seen that the cheapness and abundance of the aluminium depends very much on the cost of the sodium, and the quantity in which it can be produced. Till quite recently, the price of sodium was as high as 5 shillings a pound; and the process of manufacture was so difficult, and even dangerous, that very large quantities could not be obtained. The improvements effected by Mr. Hamilton Y. Castner in the manufacture of sodium, by which it can be made in any quantity without the slightest risk at about 1 shilling per pound, has rendered it possible to produce aluminium of about 98 per cent purity which can be sold profitably at 20 shillings per pound.

The object of a paper by William Anderson, in a recent number of the *Journal of the Society of Arts*, London, is to describe the process of manufacture adopted by the Aluminium Company, at the works, which have just been started, at Oldbury, near Birmingham.

We will first take the manufacture of the double chloride of aluminium and sodium. The raw material is hydrate of alumina ($\text{Al}_2\text{O}_3 + \text{water}$), which is the only oxide of aluminium. It can be prepared in a variety of ways, and from various materials, such as potassium alum, which is the double sulphate of aluminium and potassium, $\text{Al K}(\text{SO}_4)_2 \cdot 12\text{H}_2\text{O}$; bauxite, which, as already stated, is a ferruginous hydrate; and other substances; the price being about £13 per ton when it is sufficiently pure for the purpose.

The hydrate of alumina, in a finely divided state, is mixed, on a suitable floor, with lamp-black, charcoal, and common salt; moistened with water; the mass is thrown into a pug-mill, and, after being thoroughly mixed and incorporated, is forced through dies constructed exactly as in a drain-pipe machine, the issuing cylinders of the compound being cut off by wires into pieces about three inches long, which are carried to the tops of the chloride furnaces, and spread out there to dry thoroughly.

The next process is to expose the mixture of hydrate of alumina, carbon, and salt, to a high temperature in presence of chlorine gas, in order to obtain the vapor of the double chloride, which is distilled over, and condensed in the form of a deliquescent, light-yellow substance of very pungent odor. This operation is performed in regenerative furnaces, constructed very like banks of ordinary earthenware gas-retorts. The gas from the producers plays round groups of five retorts, set in ovens, in which their temperature is raised to a bright-red heat, the exact intensity of which is a matter of much importance, and requires an experienced eye to regulate.

The retorts are connected at their mouths—that is, their opening ends—by means of earthenware pipes to gas-holders containing chlorine gas, special means being taken to regulate the pressure of the gas and the rate at which it is allowed to flow. The opposite ends of the retorts are fitted with pipes, which convey the fumes of double chloride to cast-iron condensers, and thence to brick chests or boxes, the outsides or ends of which are closed by means of wooden doors. Convenient openings are arranged for clearing out the passages, because the double chloride condenses very quickly. The greater portion of it liquefies, and trickles down into the brick chambers; while a portion sublimes, and comes over in the form of a yellow powder. The brick chambers are emptied from time to time, and the contents packed away in air-tight wooden chests,—a precaution rendered necessary on account of the deliquescent properties of the substance. The re-action which takes place is as follows:—

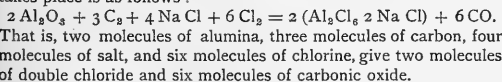

The chlorine gas used in the retorts is manufactured on an enormous scale, being prepared in the usual way, by the action of hydrochloric acid on manganese dioxide, at a moderately high temperature. One molecule of the manganese dioxide combining with four molecules of hydrochloric acid, produces one molecule of manganous chloride, two molecules of water, and one molecule of gaseous chlorine:—



The manganous chloride is soluble, and forms the "spent still liquor," which is reconverted into manganese dioxide by Weldon's

method; that is, by first neutralizing all free hydrochloric acid by means of powdered limestone, and then adding milk of lime to the neutral solution, when manganous oxide and calcic chloride are formed:—

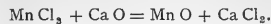

By exposing the manganous oxide to a strong current of air, it takes up another atom of oxygen, and becomes again MnO_2 , or manganese dioxide.

The chlorine plant forms a very imposing part of the factory. The hydrochloric acid is conveyed by a 2-inch gutta-percha pipe a distance of some 700 feet across the canal, from Messrs. Chance Brothers' Alkali Works. It is received into six large stone storage-tanks, each capable of containing 10 tons; and from these it is run, as it is wanted, into two large stone stills made up of huge slabs of sandstone cramped together in an ingenious manner by iron bolts and cast-iron angle saddles, the joints being made by means of solid India-rubber cord. In these stills the manganese dioxide and the acid are mixed; and, being warmed by injected steam to the proper temperature, the chlorine gas is at first given off rapidly and with effervescence. The rate gradually decreases, and at length the disengagement of gas ceases altogether. The chlorine is carried off by means of lead and earthenware pipes to four large lead-lined gas-holders, capable of containing several thousand cubic feet of gas; and from them it is led away to the double chloride retorts, various ingenious devices having been introduced for indicating the pressure of the gas, and measuring the quantity passed into each retort. Chlorine, besides being valuable, is a very disagreeable gas when it gets out of its proper place: hence great care and method are required in manipulating it.

The "spent still liquor," the solution of manganous chloride, is run into a large neutralizing well, 20 feet diameter, and 20 feet deep, built of stone, and fitted with agitators. It is there neutralized by intimate mixture with powdered limestone, and is allowed to settle, after having been pumped up to a system of tanks elevated above the oxidizing-tower, during which process iron and some other impurities are carried down. The clear solution, which has a pinkish color, is then run into the oxidizing-tower, which is a wrought-iron cylinder standing on end, about 12 feet diameter and 30 feet high, where it is warmed by injected steam. Milk of lime is added, and the whole violently agitated by a powerful current of air, pumped in at the bottom of the tower by an 80-horse-power horizontal engine driving a large double-acting air-pump. In two or three hours the manganous oxide has absorbed as much oxygen from the air-current as it had at first given up to the hydrogen of the hydrochloric acid, and thus reverts to its original state.

The contents of the tower, now a thick black turbid liquid, are run into a second system of settling-tanks, five in number, erected below the level of the tower. The tanks are each 18 feet square by 7 feet deep, and are used alternately for settling the charges as they are withdrawn from the tower. The recovered manganese dioxide settles out, leaving a clear solution of chloride of calcium, which is drawn off by overflow pipes; and the recovery process is then complete, the manganese mud being thus used over and over again, and re-recovered, suffering but an inconsiderable amount of loss in the process.

We next come to the manufacture of sodium. Previous to the year 1836, sodium was produced by reducing it from the hydrate or carbonate of soda by heating it to a very high temperature, with an excess of carbon, great care being taken to avoid fusion of the mass, to which end lime was added. Fusion was prejudicial to the process, because, when fused, the carbon separated from the alkali, and only a small return was obtained: hence the temperature had to be carried sufficiently high for the alkalis to be volatilized, because only in that form could the soda compounds come into sufficiently intimate contact with the carbon for its combination with the oxygen of the alkali to take place, and set the metallic sodium free. The high temperature required caused great wear and tear of the iron retorts in which the process had to be carried on, and dangerous explosions were not uncommon; the practical effect being that the production of sodium was very limited in quantity, and the price, as already stated, ranged as high as 5 shillings per pound.

Mr. Castner, a chemical engineer of New York, became pos-

sessed of the idea, that, if suitable means were discovered, it would be possible to reduce the sodium and potassium compounds at a much lower temperature by bringing the carbon into intimate contact with the alkalis in a molten condition. If six molecules of the hydrated oxide of sodium, commonly called caustic soda, be added to one molecule of carbon, it will yield, when heated to a high temperature, two molecules of carbonate of soda, three molecules of hydrogen, and one molecule of sodium, —

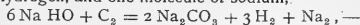

and the reduction will take place in an atmosphere of hydrogen, provided that a sufficiently intimate contact can be secured between the carbon and the alkali. Mr. Castner's process to attain this end, arrived at after a couple of years of patient experiment, is partly mechanical and partly chemical. He prepares an artificial carbide of iron by coking an intimate mixture of finely divided iron and pitch, or other hydrocarbon; the result being a heavy metalliferous coke, which, when ground fine and mixed with caustic soda in the fused condition, blends intimately with it, and causes the reduction of the soda at a temperature very much below that hitherto found possible, namely, below that of melting silver, which has been estimated to be about 1000°C . The chemical re-action during reduction cannot be confidently defined, but it probably is somewhat according to the following formula: —

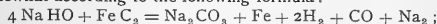

that is to say, four molecules of caustic soda and one molecule of the carbide of iron, as above defined, produce, in the liquid form, one molecule of carbonate of soda and one atom of iron; while two molecules of hydrogen, one molecule of carbonic oxide, and one molecule of sodium, escape in the gaseous state. The hydrogen and the carbonic oxide ignite, and burn with a brilliant flame colored by the characteristic sodium hue, while the sodium distils, and condenses into suitable vessels. The reduction thus takes place in an abundant atmosphere of hydrogen and carbonic oxide, which effectually preserves the sodium from oxidation till it can be safely deposited in mineral oil.

The apparatus for preparing the sodium is sufficiently simple. The caustic soda is received in drums from the neighboring alkali works of Messrs. Chance Brothers. The finely divided iron is mixed with melted pitch in iron pots set in a suitable stove, and the mixture of pitch and iron is then calcined into coke in large iron retorts set in an ordinary furnace.

The metalliferous coke is ground into a fine powder by means of ordinary edge-runners, and is ready for charging into the sodium-retorts, which are of specially ingenious construction, and deserve a detailed description. Each furnace is heated by gas, applied on the regenerative principle, and contains five cast-steel crucibles, or pots of an egg-shaped form, arranged with their long axes vertical. The upper part of the egg is formed into the head or cover, much like the artificial Easter eggs which contain sweets; but it is fitted with a vertical pipe, which passes up through the top of the furnace, and forms the passage by which a portion of the charge is introduced, and it also has a lateral branch connected to the condenser, which consists of a small cast-iron vessel of peculiar form, arranged so as to allow the fluid sodium to trickle out, to let the hydrogen and carbonic-oxide gases escape, and to afford facilities for cleaning the passage, so as to prevent it from becoming choked. The form of this condenser is of some importance, if the best results are to be obtained. The whole of the head above described is secured immovably in the upper part of the furnace, and is protected by the oven-setting from extreme heat; it can, however, be readily removed if desired. The lower part of each retort rests on the top of a vertical hydraulic lift, which is worked by a moderate water-pressure, provided by a special duplex pump; and it is this pressure, which, with the interposition of some luting, forms the joint between the head of the retort and its lower portion. The upper part of the lift or platform is so arranged, that, when the retort resting on it is in its place, the aperture in the bottom of the furnace is completely closed. When the lift is lowered, the bottom half of the crucible sinks to the floor level; and a two-wheeled iron hand-truck of special construction is wheeled up, and catching hold of the crucible by two projections on its sides, provided for the purpose, lifts it off the hydraulic ram, and by the aid of two men transports it to the "dumping" pits, on the edge of which it is

turned on its side; the liquid carbonate of soda and finely divided iron, which form the residue, are turned out; and the inside is scraped clean from the opposite side of the pit, under the protection of iron shields. When clean inside and out, the crucible is again lifted by the truck, and carried back to the furnace, receiving a portion of the fresh charge on its way. It is then again placed on its ram and lifted to its place, having still retained a good red heat. It takes two minutes only to remove and clear a crucible; from six to eight minutes performs the same office for the set of five; and the whole cycle of operations, including the distilling of the sodium, requires one hour and fifteen minutes. The five crucibles yield 500 pounds of sodium per twenty-four hours; so that the battery of four furnaces is competent to yield 2,000 pounds, or nearly one ton, of sodium per day.

The only portions of this plant liable to exceptional wear are the bottom halves of the crucibles, the durability of which is found to depend very much on the soundness of the cast steel of which they are made, because any pores or hollows are rapidly searched out by the furnace flames. The average duration of each crucible at present is about 750 pounds of sodium, or 125 charges. The carbonate of soda removed from the retorts is returned to the alkali-makers, and is again converted into caustic soda, fit for further use.

The six pounds of sodium, the produce of each charge, is allowed to trickle from the condensers into small iron pots, in which, when cool enough, it is covered with mineral oil, and then transported to the sodium-store, where it is melted in large pots, which are heated by an oil bath, and cast into ingots of convenient form for the subsequent operations. The strong affinity of sodium for oxygen is well known; hence it is best kept covered by an oil, such as mineral oil, which does not contain oxygen in its composition; and the greatest care has to be taken to protect it from water, because water is decomposed with so much energy by sodium, that the heat caused by the clashing-together of the atoms of sodium and the oxygen of the water is sufficient to ignite the liberated hydrogen. Hence the apparent paradox, that, to make the sodium-store fireproof, it is necessary to make it waterproof also, and at the same time to avoid naked lights, which may chance to set the vapor from the oil on fire.

We have now got the two ingredients required for the production of aluminium; namely, the double chloride of aluminium and sodium, and metallic sodium. The double chloride is broken into small pieces, and mixed with cryolite (the native fluoride of aluminium and sodium, $6 \text{Na F Al}^2\text{F}^6$), and with metallic sodium cut into thin slices by an ordinary tobacco-cutting machine. The mixture is tightly enclosed in a revolving wooden box, in which it gets thoroughly mixed. This part of the process is somewhat trying, on account of the hydrochloric-acid gas given off by the double chloride, which slowly decomposes when exposed to the air. When the ingredients are sufficiently mixed, they are turned out on to the hearth of a regenerative reverberatory furnace, over which the mixing cylinder is placed. The hearth is made to slope towards a lateral opening, which is closed during the process of reduction by clay, supported by iron plates and keys. There are two furnaces, — a small one, capable of producing 60 pounds of aluminium per charge; and a large one, which yields 140 pounds. The charge introduced into the furnace melts quickly; and a reaction, represented by the following formula, takes place: —

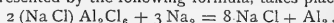

That is to say, one molecule of the double chloride and three molecules of sodium yield eight molecules of common salt and one molecule of aluminium. The process of reduction lasts about three hours. The melted slag, which consists chiefly of common salt and the cryolite (which merely served as a flux), is drawn off by breaking the clay stopping of the hearth-opening from above downwards; and finally the lower tapping-hole is broken through, and a silvery stream of metallic aluminium runs out, and is received into cast-iron moulds. The reducing operation requires considerable skill, and great attention to the temperature of the furnace, which has to be varied during the continuance of the re-action.

The large furnace is competent to produce 840 pounds of aluminium per day of twenty-four hours; and the small one, 360 pounds.

The first portion of metal which runs out, and which forms rather more than three-fourths of the charge, is of the greatest purity; the remainder, which has to be scraped off the hearth, or which gets entangled in the slag, and has to be subsequently separated out, contains a larger proportion of foreign substances. The cause of the difficulty in obtaining the separation of the metal from its slag consists in the very low specific gravity of aluminium.

The metal is now taken to the casting-house, arranged like an ordinary brass foundry, is remelted in plumbago crucibles, and cast into ingots, plates, or bars for subsequent sale or manufacture.

It is evidently impossible to here enter into all the details of manufacture, although these details are of the highest importance in obtaining commercially valuable results. Day by day, as the manufacture progresses, improvements are made which either enhance the economy of production or increase the purity of the sodium or aluminium produced. Such improvements in details cannot very well be made public till their value is thoroughly ascertained, and the protection of the patent law obtained when considered necessary.

The following table gives the quantities of the several ingredients employed to make one ton of aluminium:—

Metallic sodium	6,300 lbs.
Double chloride	22,400 "
Cryolite	2,000 "
Coal	8 tons.

To produce 6,300 pounds of sodium are required—

Caustic soda	44,000 lbs.
Carbide made from pitch (12,000 lbs.) and iron turnings (1,000 lbs.)	7,000 "
Crucible castings	2½ tons.
Coal	75 "

For the production of 22,400 pounds double chloride are required—

Common salt	8,000 lbs.
Alumina hydrate	21,000 "
Chlorine gas	15,000 "
Coal	180 tons.

For the production of 15,000 pounds of chlorine gas are required—

Hydrochloric acid	180,000 lbs.
Limestone dust	15,000 "
Lime	30,000 "
Loss of manganese	7,000 "

The works are constructed so as to produce 1½ tons of aluminium per week: the quantities of the ingredients consumed are consequently half as much again as the figures given in the table. It is easy to see, therefore, that the factory must be on a very large scale; and the brief account of the process here given indicates also how complicated the manufacture is, and how much care and skill are necessary to conduct it successfully, if pure aluminium is to be made. The great enemies of the metal are iron and silicon, especially the former. When once it gets in, it is impossible to get it out again by any commercially practicable means: hence every precaution has to be taken to insure the purity of the materials; to which end a well-appointed laboratory, presided over by Mr. Baker, a very able chemist, is kept in active operation.

Aluminium is endowed with several remarkable properties. It is the lightest of the metals which possess considerable tenacity and hardness. A given volume of aluminium is only a little more than 2½ times (2.65) the weight of an equal bulk of water; whereas iron is 7½ times, copper nearly 9 times, gold 19½ times, and platinum 21½ times, as heavy as water. The metal has a bright silvery lustre. It is capable of taking a very high polish, and of retaining its brilliancy and color under conditions which would rapidly tarnish silver, because it does not oxidize from exposure to either dry or damp air, and is unaffected by that great enemy of silver, sulphuretted hydrogen, or other sulphur compounds present in London fogs, either at ordinary temperatures or even at a red heat. At ordinary temperatures it is not affected by either strong or diluted nitric acid. Weak sulphuric acid has no action on it, neither have sulphuretted hydrogen or sulphide of ammonium, which explains the reason why it does not tarnish, even in very impure atmospheres. Water has no effect on pure aluminium under ordinary

conditions; but, if it be made the oxygen pole of a galvanic battery, it is readily converted into alumina, forming a copious white precipitate. The vegetable acids, such as acetic and tartaric, have no effect: hence aluminium is admirably fitted for making into cooking utensils, coffee-pots, teapots, etc., its extreme lightness being also an advantage for this purpose. It is not acted upon by the hydrates of potassium and sodium in a state of fusion; but solutions of these alkalis in water dissolve it readily, forming aluminates of potassium and sodium, with evolution of hydrogen. Of this property the silversmith takes advantage in producing very beautiful frosted effects, by plunging the polished metal for an instant into a weak solution of caustic soda, washing in a large quantity of water, and then digesting in strong nitric acid. Its powers of conducting heat are high in the scale, being about two-thirds that of copper; its specific heat is .22, only lithium, sodium, and magnesium being above it. Its electrical conductivity is eight times higher than that of iron, and about equal to that of silver. Its elasticity and tenacity are equal to that of silver, and have been determined by Mr. W. H. Barlow at about 12 tons per square inch; but weight for weight, its tenacity would be the same as high-class steel, or 36 tons per square inch, that is to say, bars of equal weight would carry the same loads. Experiments on very fine wire have given the same results. It is very malleable and ductile, when proper attention is paid to annealing during the process of working,—a precaution common to the manipulation of most metals. Aluminium of about 97 per cent to 98 per cent purity may be rolled into thin sheets, and may be beaten into foil as thin as any that can be produced from silver and gold. It can be drawn into very fine wire, of only one-tenth of a millimetre diameter, and ought to supersede silver in the manufacture of metallic braid and tissues, because it will never tarnish as silver does. It can be stamped or spun into hollow ware, but there is as yet some difficulty in soldering it; at any rate, the process of performing the operation is known to very few people.

Aluminium forms alloys with most metals. Iron is always more or less associated with it; but it seems doubtful whether it be a true alloy, or wholly or in part a mixture, like the carbon contained in cast iron and in steel. Silicon is also invariably found associated more or less with the metal. Aluminium added to molten iron and steel lowers their melting-points, and consequently increases the fluidity of the metal, and causes it to run easily into moulds and set there, without intrapping air and other gases, and forming blow-holes and similar imperfections. It is in consequence used to the extent of about ½ per cent and less by some steel founders, and seems to render the production of sound steel castings more certain and easy. Admiral Kolokolzoff, the director of the great gun-factory near St. Petersburg, uses ferro-aluminium,—an alloy with iron, containing 10 per cent of aluminium,—and adds it to the crucibles of melted steel about ten minutes before pouring, in the proportion of one pound of the alloy to 80 pounds of steel, which gives one part in 800 of pure aluminium; and the result is that he gets the largest steel castings, completely free from air-bubbles, and with very excellent mechanical properties.

One of the most remarkable applications of the property which aluminium possesses of lowering the melting-point of metals has been made by Mr. Nordenfelt, in the production of castings of pure iron; that is to say, iron free from any sensible quantity of carbon or manganese. Pure iron melts at about the same temperature as platinum, that is, about 1700° C.; yet even then the molten mass is not liquid enough to be run into moulds, but the addition of from $\frac{1}{2000}$ to $\frac{1}{700}$ part by weight, of aluminium, lowers the melting-point to such an extent that it becomes fluid enough to run into the most minute and intricate forms. Mr. Nordenfelt has given the name of "mitis" (flexible ductile) to his metal. Mr. Anderson then called attention to a wire brush of solid casting, the back and iron bristles forming one mass, and yet the bristles may be bent about just like the softest iron wire.

The process of manufacture is as follows: Wrought iron is placed in crucibles, which are put into a liquid-fuel air-furnace of peculiar and ingenious construction. In a furnace for six crucibles, for example, they are arranged on an elongated hearth in pairs, cross partition walls being so built as to cause the flame to embrace each crucible thoroughly. In the roof of the furnace are

openings, covered by movable, brick-lined plates, or doors, through which the crucibles can be got at. The flame playing over the hearth is conveyed by a short flue, fitted with a damper, to the chimney. Under the hearth is another flue communicating with the furnace, and also leading to the chimney, and fitted with a damper. By manipulating the two dampers, the flame may be directed either under or over the hearth at pleasure. The furnace proper is at the end of the hearth farthest from the chimney, and consists of a peculiarly constructed apparatus, whereby the cheap residues resulting from the distillation of kerosene, or the heavy oils obtained from gas-works, can be burned with the ordinary chimney-draught, and a most intense heat produced. The pair of crucibles next the furnace are the most highly heated. The metal in them melts first, and, as soon as the crucibles are removed for pouring, the remaining four are moved up near the flame, and two freshly charged ones put in at the end nearest the chimney, by which means most of the heat produced by the combustion of the fuel is utilized. As soon as the iron is fairly melted, but not overheated, aluminium is added, when the charge instantly becomes quite fluid, and fit for pouring, the lowering of the melting-point having had the same effect as superheating the metal.

The mits castings possess all the properties of the best forged iron, the tensile strength ranging as high as 27 tons per square inch, with an elongation of 20 per cent. The metal can be worked and welded just like wrought iron, and in fact cannot be distinguished from it, except that it is perfectly homogeneous and free from stratification.

When aluminium is used in such small quantities, it is best to make a preliminary rich alloy with iron (say, one containing from 10 per cent to 25 per cent of aluminium), and then to add so much of the alloy to the charge in the crucibles as will give the desired proportion of the more costly metal. This is the more necessary on account of the extreme lightness of aluminium, which makes it reluctant to mix with a metal three times its specific weight.

Aluminium alloys readily with copper in all proportions, and constitutes the metal known as aluminium bronze. The usual proportion ranges from 2½ to 10 per cent of aluminium; and it is probable that the bronzes resulting form true alloys or solutions, because the addition of the lighter metal causes a marked increase of temperature of the molten mass, indicating the existence of chemical re-action; and the bronzes may be melted frequently without changing the relative proportion of the constituent metals. The tenacity and rigidity of the copper are much enhanced; 10-per-cent alloys having sustained as much as 45 tons per square inch, with an ultimate extension of 25 per cent. It must be remembered, however, that, to obtain the best results, absolute purity, or, at any rate, fixity of composition, both in the copper and aluminium, must be insured. Failing that, very discordant and disappointing results will be arrived at. The aluminium alloys of copper, up to 10 per cent, can be forged, and rolled hot, and worked as readily as copper, proper precautions with respect to annealing being observed. The color of the aluminium bronzes approaches very nearly that of gold. The metal takes a high polish, and is less liable to tarnish than ordinary bronzes or than copper itself.

Aluminium forms alloys with most other metals; but they possess no practical value at present, and therefore need not be described.

A discussion followed, in which Mr. E. Riley said he had gone into this question many years ago, when Sir Lowthian Bell brought out his process, and he had some experience of the so-called alloys of aluminium, having had numerous samples submitted to him. He wished to ask whether the Aluminium Company had any process by which the aluminium could be got from clay. With regard to the result of the alloys, he thought that practically the alloy of copper had proved very satisfactory, but, when they came to analyze it, no aluminium was found, except, perhaps, a mere trace. Some mits castings were submitted to him a few years ago by Mr. Nordenfeldt, but he found no aluminium in them; and so it was in the so-called alloys. He had also had several samples from America. There was nothing more easy to find than aluminium, but it might be there were several things which could be confounded with it. As regarded the action of aluminium on metals, his view was that it took away the oxygen, and made the casting more solid. It

was important to the Aluminium Company to know whether any of the processes put forward really reduced alumina or not. It was not an easy matter to find small quantities of aluminium. He had had samples submitted to him which were said to contain 2½ per cent, but he could only find a small trace. He believed that aluminium would be a very valuable adjunct in making steel castings, and it was now being used. He had seen samples of cast iron in which it had been used, and found the castings exceedingly good, besides showing a considerable amount of strength.

Mr. Jeans bore testimony to the admirable way in which the company's works were conducted, and considered they reflected great credit on the inventor. There was only one other system which had all at once been brought so near perfection by its inventor; viz., the Bessemer process. Having come into contact with people who were likely to use the metal, he thought the general impression was that it would prove a valuable adjunct to the various forms in which iron and steel were manufactured. It was said that it would be an important element in the production of steel castings; but he was afraid, from the limited quantity of steel castings produced in England, that it would not be largely used for that purpose for some time to come, though in the production of mits castings and the like it might be employed on a larger scale. Taking the production of pig-iron in the United Kingdom as about 7,500,000 tons a year, he should be disposed to say that rather more than 2,000,000 tons were employed in the production of Bessemer steel, 1,000,000 tons in the Siemens process, and 2,000,000 tons in the production of manufactured iron, leaving rather over 2,000,000 tons for castings and other purposes. The technical literature of this country, the Continent, and the United States for some time past, had teemed with references to the subject; and experiments had been made on a large scale, which indicated, that, for castings of every description, this metal was especially valuable. For some time it had been a disputed point how far aluminium was an important element in the production of steel. Professor Faraday undertook researches into the subject in connection with Wootz steel; but his conclusions were disputed by eminent chemists, who went over the same ground; and, if his memory served him accurately, Faraday considered the good properties of Wootz steel due to the fact that there was a small percentage of aluminium in it. There could be no question, from what they had seen that night, that there was a great future for the new metal in connection with the metallurgy of iron and steel; and the effect of the paper would be to throw a new light on the subject, and to inform the outside public of a matter which was of high scientific and commercial importance. He thought the time would come when those who used aluminium for alloying purposes would prefer to have a metal in the purest condition in which it could be produced, in order that they might infuse into the casting such a proportion of aluminium as they might deem to be essential for certain specific purposes. In that way the field in the future would belong to the process which could produce the purest aluminium.

Mr. Alexander Siemens was afraid he occupied the rather invidious position of finding fault with this very excellent process, which gave plenty of opportunities of allowing impurities to get into the aluminium. This fact was admitted in the paper. He had been asked by the inventor of a rival process to describe it, which might be done in a very few words. Mr. Grabau produced a fluoride of aluminium by certain means, and it was heated until it began to evaporate. When this temperature was attained, a suitable quantity of sodium was melted and poured into the vessel, which was lined with cryolite and cooled by water; and the heated fluoride of aluminium, in the form of powder, was thrown upon the melted sodium. Very violent re-action took place, and the heat generated by the re-action was great enough to melt the aluminium as well as the by-product. As soon as the re-action was complete, the whole molten mass could be poured out in suitable forms; the aluminium settled at the bottom, and the cryolite at the top. To obtain the fluoride of aluminium, Mr. Grabau used the cryolite, which he procured by the final re-action by putting the powdered cryolite into a solution of sulphate of aluminium. The re-action which took place between the sulphate of aluminium and the cryolite gave the aluminium fluoride. The solution was afterwards evaporated, and the residue was washed with water, which took out the sul-

phate of sodium, and left the aluminium fluoride ready to be reduced. The advantages of this process were that all the materials were treated at a comparatively low temperature. The vessel in which the aluminium fluoride was heated, as well as the vessel in which the re-action took place, was lined with cryolite, so that there was no danger of impurities being imported into the aluminium which was the result of the process. The low temperature was very much easier managed than the high temperatures of which Mr. Anderson had spoken.

On the chairman asking what temperature was necessary, Mr. Siemens replied about 900° (Celsius), just above a dull red. The process, of course, required the action of sodium, and the inventor was engaged in experimenting upon a new process to prepare this; but, as the necessary patents had not yet been taken, he was not at liberty to describe it in detail. At a short distance from Hanover the factory was at work producing aluminium on a commercial scale, though it was not on the magnificent scale of Mr. Castner's; but the process was extremely simple, and the extremely clever way in which the by-products were used promised exceedingly well for the process.

Mr. W. Boby said it appeared from the tables that 263 pounds of coal were used to produce 1 pound of aluminium; and this, to his mind, seemed a very formidable figure. He was himself connected with a rival process for manufacturing aluminium, which was in practical work, by the use of the electric furnace. This process did not produce pure aluminium; but one of the great and important uses of aluminium was as an alloy. If you got a pure aluminium, it was an extremely light metal, and it was very difficult to alloy it with iron. In the Cowles process the aluminium was produced in the furnace, and it was alloyed with iron, and came out in the proportion of 12 or 16 per cent of aluminium to the entire mass of the product. The aluminium in the alloy may be considered pure, as we know the other constituents. It was reduced from a hard white clay known as bauxite. The interior of the furnace was 5 feet long and 2 feet deep. They had a dynamo, which gave a current at 60 volts of 5,000 amperes, and it was conveyed through the furnace by means of carbon electrodes. The charge of bauxite and broken iron was put into the furnace, which was luted with charcoal to resist the heat, the current was turned on, and in an hour and a half they tapped the furnace and got out the charge of alloy. In the mean time the bauxite had become reduced from the intense heat in the furnace. There was a certain admixture of carbon in the charge, which formed a resistance to the current, and enabled it to diffuse heat through the charge. About 200 pounds of aluminium were produced per day. In answer to the chairman's question as to the percentage of the silicon which the alloy of iron contains, he could not tell the exact percentage, but he knew it was not a large one. In the copper alloy, in making 10 per cent bronze, the percentage was about .5.

Mr. Oliver J. Williams asked whether Mr. Anderson knew any thing of Brin's aluminium process, which he understood produced aluminium alloy from clay at a very small cost.

Mr. Anderson, in reply to Mr. Riley, said that wrought iron had been cast into large ingots, and the Germans had a cast-wrought iron; but it was new to him to hear that small and delicate castings, such as those exhibited, had been made without the use of aluminium. He did not think it could be done. Bauxite was a species of clay, and they had to pick out a material which had the greatest purity. If you could get it at a reasonable price, it was better to use a pure material than one which was impure, and have to get out the impurities afterwards. In steel a fractional percentage of carbon made a wide difference in the quality. He was not surprised, therefore, to find that aluminium would produce wonderful effects in the quality of the casting, and yet be scarcely distinguishable in the product. He was sorry to hear from Mr. Jeans that aluminium was not likely to be used very extensively in steel castings, and thought he was mistaken in this respect.

Mr. Jeans said what he meant to say was that the quantity of steel castings made in England up to the present time was so small, that the quantity of aluminium to be used would be comparatively small, at any rate until the production of castings had extended.

Mr. Anderson said that the production of steel castings was

increasing immensely every day. Aluminium would be used for the following reason; that when one made a bad steel casting it was a desperate job to get rid of it. It was very important to be sure that the castings made were sound; and, when aluminium could be obtained pure, it would come very much into use. It was no use making impure aluminium. It was quite possible, with a little extra expense, to get aluminium containing only one per cent of impurity. French aluminium had had the pre-eminence in this respect up to the present, but the purity of the French material had not exceeded 98 per cent. If aluminium could be got at 99 per cent of purity, or even a little above this, it would be an invaluable material for the manufacture of fine wire for making into braid, as it did not tarnish. The process referred to by Mr. Siemens was a very interesting one, and the only objection to it was the use of cryolite. The Aluminium Company were doing their best to get rid of the use of cryolite.

Mr. Siemens said the cryolite was a by-product of the raw product; it was made from the sulphate of aluminium.

Mr. Anderson thought that any process which would produce the metal on a large scale, and cheaply, would be a great advantage. He was not aware that any aluminium was made of a greater purity than 98 per cent, or at a lower price than 40 shillings per pound. His paper had nothing to do with the electrical process for making aluminium alloy.

BOOK-REVIEWS.

Suggestive Therapeutics: a Treatise on the Nature and Uses of Hypnotism. By H. BERNHEIM, M.D. Tr. by Christian A. Herter, M.D. New York and London, Putnam. 8°. \$3.50.

HYPNOTISM is no longer a novelty. Its long apprenticeship among the charlatans has been served; the ill name it gained during the days when pretension took the place of proof has been outlived; its apparent contradiction to the recognized laws of physiology has been minimized, if not removed. It holds a recognized place as a psychological method, as an extension of the domain of medicine, as a most promising field of scientific psychological advance. However interesting would be the history of the steps by which this favorable change of aspect has been accomplished, it must for the present be dismissed with the remark that it was in France that the movement grew and prospered, and it is to French scientists that most of our knowledge is due. The object of Dr. Bernheim's work is to give an exposition of the present appearance of the topic, especially with reference to its application to practical medicine.

At the risk of repeating what is well known, it must be prefaced that students of hypnotism are divided into two camps,—the school of Paris, of which Dr. Charcot is the leader; and the school of Nancy, represented by Dr. Bernheim. The former recognize three stages of hypnotism marked by constant physiological characteristics, transition from the one to the other of which is obtained by physical means; they believe, too, in the action of the magnet upon hypnotic patients, regard the appearances in hysteria as typical of hypnotism, and in part lay claim to such abnormal effects as the action of drugs at a distance. The school of Nancy may be characterized as "suggestionists," for this is the keynote of their view. They regard the phenomena as psychical in origin, recognizing no physical effects except as they act upon the mind; and they see differences of degree in the various stages of hypnosis, but no sharp distinctions of kind; furthermore, they assimilate the appearances to natural sleep, repudiating all claims to supernatural effects.

In this work of Professor Bernheim's we have the best exposition of the Nancy school,—a view, it should be added, that is daily gaining ground, and has received the sanction of almost all the German, Swiss, and Italian investigators, who have critically examined both views. No work is better suited for translation into English; and, with the translation of Binet and Féré's "Animal Magnetism," the English reader is favorably situated for gaining a clear insight into this enticing study. The arrangement of the book is capable of improvement. After explaining the modes of producing the state, the various degrees of its intensity, the rôle of

memory in the process, a chapter is devoted to a rather miscellaneous description of the appearances in a typical subject. The relation of these facts to the influence of mind over body is next ably discussed, and this is followed by a study of suggestion in the waking state. Here the exposition is interrupted by a controversial chapter, and the course of thought again changed to afford room for a brief historical sketch. Theoretical considerations conclude the first portion of the work. Part II. consists of a careful analysis of over one hundred cases in which the curative effects of suggestion were illustrated, with some account of the nature of the action in such cases. These cases are derived from the most various types of disease, and prove, that, in the hands of a careful expert, this means of betterment and cure is most valuable. Instead of filling out the skeleton plan of the work just given, it may be more serviceable to the prospective reader to illustrate the chief results of this laborious study.

The hypnotic condition is found to be only a somewhat extreme case of natural sleep. Every night we place ourselves in an accustomed attitude, seek a monotonous course of ideas, and will to go to sleep. It is auto-hypnosis. In artificial hypnotism the sleeper remains subject to the control of an operator, because that is the dominating idea in going to sleep. From this it follows that no one can be hypnotized totally against his will: the patient must have some notion that something unusual is to happen. Time and again has an operator, unknown to the subject, willed the latter to sleep, but to no purpose. Just as in sleep the will is subdued but not extinguished, so in hypnotism the patient is not totally in the hands of the operator. An act shocking to the moral susceptibilities must be insisted upon, and repeatedly, before it is executed. Nor is the individuality of the subject lost. His past attainments are all that can be drawn upon: no new power is developed, but the hidden recesses of the unconscious are ransacked.

A distinctive point is the memory the subject retains of what was done during the hypnotic condition. In all the deeper stages, upon awakening, nothing is recalled: the interval is a complete blank. But Dr. Bernheim most ingeniously shows that the knowledge is latent only, not lost. By careful hinting, the subject can be made to recall all that happened; and, if a suggestion be given that he is to recall what happens, then remembrance is complete. It is at this stage that the medico-legal interest centres. The unconsciousness of the victim would be the safeguard of the criminal. Not only this, but a suggestion can be given that hours, days, or weeks after awakening, the subject is to commit some outrage, and insist that it was done of his own free choice. In some cases "retro-active" suggestions are possible. The subject is told that he has been a witness to certain acts. He assimilates the incident to his experiences, elaborates it, and is certain of his testimony. The Tisza-Esler affair is a case in point. The judicial complications arising from these facts have yet to be satisfactorily solved.

Hypnotism magnifies the action of the mind upon the body, shows that processes usually beyond voluntary control or influence can by extreme attention be psychically influenced, wounds can be made and cured, the pulse be slowed or quickened, and even stigmata be produced. Here lies the essence of all the mind-cures; and it is only by a conscientious study of all such facts that mental healing can be placed upon a sound basis. Hypnotic cures act by keeping up a hopeful disposition, by focusing the attention on the object of cure, by dispelling worry, — all naturally efficacious processes. It is avowedly impotent in cases of organic lesion, but finds its special application in cases of impairment of nervous function.

Finally, hypnotism illustrates the extremely subtle steps of unconscious suggestion. The least change of facial expression, indicative of surprise, of gratification, of anxiety, is enough to give the clew to a sensitive subject. In this way many observers have been misled into attributing to physical or more mysterious influences what they have unconsciously suggested. This fact makes this field of study at once fascinating and treacherous. It requires peculiar talents and great shrewdness.

Such are a few of the main points which hypnotism has contributed to a scientific psychology. This contribution is of the greatest value, and especially when contrasted with the pernicious tendencies of the uncritical and sensational consideration of the same phenomena thereby displaced. While great credit is due to

Dr. Charcot and his associates for introducing the scientific era into hypnotism, and braving the contempt that such a step involved, equally great is the merit of the school of Nancy for relieving the phenomena of much of their mystery, and adding in every direction to our knowledge of these valuable conditions.

Natural Inheritance. By FRANCIS GALTON, F.R.S. London and New York, Macmillan. 8°. \$2.50.

MR. GALTON hardly needs an introduction to American readers. His researches into the heredity of genius, his study of the predominant traits of English scientists, his invention of composite photographs, together with a large number of interesting and original memoirs, have made his name and work known wherever new applications of scientific methods are appreciated. In the present work the author takes up the general problem of the processes of inheritance, upon special aspects of which he has expressed his views upon various occasions. His data are derived from entries according to the plan of the "Record of Family Faculties." This, it will be recalled, is a convenient book for the recording of the chief physical and mental characteristics of an individual, his parents and grandparents, his brothers and sisters, his own children, and so on. Prizes were offered for the most complete sets of such records; and from the answers to this competition for the prize, as well as from measurements taken at the Health Exhibition, Mr. Galton is able to deduce a few important and many subsidiary results.

A prominent feature in the present work is the application of the "probability curve" to the facts of physical variation, — an attempt to apply mathematical conceptions in the field of biology, and to found a science of biological statistics. We know that if a large number of men be measured, and the number of men between equal differences of height, let us say to each inch, be counted, the result will be somewhat as follows: the largest number of men will be found in the inch of height containing the exact average height of all the men measured, and to either side this number will very rapidly decrease as we depart from the average. What the probability curve does is to predict this rate of decrease, and to tell us how many men will be found at each degree of variation from the mean result. The test has been applied to quite a number of physiological characteristics, and with success; the numbers actually recorded, and those which the mathematical formula requires, being in fair agreement. Wherever phenomena depend for their exact appearance upon a large number of minute causes, no one of which has a considerable effect, this law seems to dominate. "It reigns with serenity and in complete self-effacement amidst the wildest confusion. The larger the mob, and the greater the apparent anarchy, the more perfect is its sway. It is the supreme law of unreason."

A point of particular interest in this curve is the point above and below which there is an equal number of measurements. This point — known as the probable error, because, if instead of measurements we were classifying errors, it would be the error we as often exceed as fall short of — in a sense determines the entire curve, and the comparison of the probable errors of two homogeneous curves is all that is needed to show their complete similarity and difference. It is by such methods and comparisons that Mr. Galton reaches his results, and it is just because his results are founded on such careful and ingenious methods that they can be regarded as reliable and valuable.

The chief outcome of the inquiry is the establishment of the law of regression towards a mean. If we take the height of the father and the height of the mother multiplied by 1.08, — the ratio of male to female stature, — draw the mean between the two, and call this the height of the "mid-parent," then the height of the child will be nearer to the average of the race than the height of the mid-parent, and will be so in a constant ratio determined as one-third; that is, the child will, on the average, be one-third less exceptional than his mid-parent. It is found, too, that the difference between the heights of the father and mother is an unimportant factor; the children of parents differing much in height and those of parents very similar in height being the same, provided the average height of the parents be the same in the two cases. Upon this basis, Mr. Galton has constructed a device by which we set weights

at the points on a scale opposite the height of each parent, and read on another scale the most probable height of son and daughter, as well as the range of variation within and outside of which there is an even chance of his or her appearance.

At first sight, this law seems opposed to the current conceptions of heredity, by which like breeds like, and qualities gather strength as they are handed down from parent to child; but, while the tendencies of the two laws are opposed, this opposition is not a contradiction. There is still room for the appearance of qualities in families, because the exceptional father is still more likely than the mediocre one to have an exceptional son; only the chances are not in favor of having a son equally as exceptional as he himself is. This is true because the rate of regression towards the mean is a ratio, and affects all alike. However, owing to the far greater number of mediocre parents, it is more likely in a given case that an exceptional son is the exceptional child of "average" parents than the "average" of exceptional parents. The law tells heavily against the continued inheritance of particular traits, both beneficial and pernicious ones, and regards as typical the oft-observed decadence of eminent families.

The variations in eye-color, the presence or absence of the artistic temperament, — which is shown to be more prevalent in women than in men, — the tendency towards types of disease, are treated according to the same plan, and the assumption of the validity of the law is found to accord with the facts. Mr. Galton has even attempted an experimental verification. The seeds of sweet-peas differing in size were grown, and the numbers of resulting seeds of

each size were obtained, with the result that the seeds were less exceptional in size than the parent-seeds, and also in about the ratio of one-third.

Besides this chief result, the volume contains a number of minor studies, all of which will be of interest to students in various scientific pursuits. The effect of marriage selection in continuing individual traits; the distinction between traits that blend, such as the mulatto issue of black and white, and those that do not blend but exist side by side; the possible shifting of the average result by a general amelioration of the race; the means of defining quantitatively nearness of kinship, — these form some of the minor points discussed.

In leaving the volume, one is impressed with the great value of method in statistical work, with the power of mathematical treatment to give clearness to results, with the enormous labor necessary to obtain results in this definite form, and with the great possibilities that this study holds out to our posterity as a means of racial and social improvement.

AMONG THE PUBLISHERS.

E. & F. N. SPON announce "A Practical Treatise on the Strength of Materials, including their Elasticity and Resistance to Impact," by Thomas Box; "Steam Boilers, their Management and Working on Land and Sea, Thirty Years' Experience," by James Peattie; and "The Voltaic Accumulator, an Elementary Treatise," by Emile Reynier, translated from the French by J. A. Berly, C.E.

Publications received at Editor's Office, March 25-30.

ADAMS, R. C. Pioneer Pith. The Gist of Lectures on Rationalism. New York, Truth Seeker Co. 99 p. 16^o. 25 cents.
MIXTER, W. G. An Elementary Text-Book of Chemistry. New York, Wiley. 459 p. 12^o. \$2.50.
STEVENSON, E. I. Janus. Chicago, New York, and San Francisco, Belford, Clarke, & Co. 182 p. 16^o.
WRIGHT, Julia Mc N. Sea-side and Way-side. (Nature Readers, No. 3.) Boston, Heath. 297 p. 12^o.

D. APPLETON & CO.

HAVE JUST PUBLISHED

I.

A Treatise on Co-operative Savings and Loan Associations,

Including Building and Loan Associations, Mutual Savings and Loan Associations, Accumulating Fund Associations, Co-operative Banks, etc. With Appendix containing Laws of New York, Pennsylvania, and Massachusetts, Forms for Articles of Associations, By-Laws, Account-Books, etc. By SEYMOUR DEXTER, President of "The Chemung Valley Mutual Association." 12mo, cloth, \$1.25.

II.

The Playtime Naturalist.

By DR. J. E. TAYLOR, F.L.S., Editor of "Science Gossip." With 366 Illustrations. 12mo, cloth, \$1.50.

"As the writer," says the author in his preface, "was once a boy himself, and vividly remembers the never-to-be-forgotten rambles and observations of the objects in the country, and, moreover, as he treasures up such reminiscences as the most pleasant and innocent of an active man's life, he thought he could not do better than enlist this younger generation in the same loves and the same pleasures."
"The work contains abundant evidence of the author's knowledge and enthusiasm. . . . The style is clear and lively, and there are many good illustrations."—*Nature*.

I, 3, & 5 BOND STREET, NEW YORK.

LONGMANS, GREEN & CO.'S NEW BOOKS.

LONGMANS' NEW ATLAS: Political and Physical, for the Use of Schools and Private Persons. Consisting of 40 4to. and 16 8vo. Maps and Diagrams, besides Insets and 16 4to. Plates of Views, &c. Engraved and Lithographed by EDWARD STANFORD. Edited by G. G. CHISHOLM. Imp. 8vo., \$4.00.

A TEXT-BOOK OF ELEMENTARY BIOLOGY. By R. J. HARVEY GIBSON, M.A., F.R.S.E., Lecturer on Botany in University College, Liverpool. Crown 8vo., \$1.75.

"As a text-book of elementary biology it is one of the best that has ever been published; the illustrations are excellent, and are to a great extent original. The typography and general execution of the book leave nothing to be desired."—*Science*.

A HANDBOOK OF CRYPTOGRAMMIC BOTANY. By ALERED W. BENNETT, M.A., B.Sc., F.L.S., Lecturer on Botany at St. Thomas' Hospital, and GEORGE MURRAY, F.L.S., Senior Assistant Department of Botany, British Museum. With 378 Illustrations. 8vo., \$5.00.

No general handbook of Cryptogrammic Botany has appeared in the English language since Berkeley's published in 1857. The present volume gives descriptions of all classes and more important orders of Cryptogams, including all the most recent discoveries and observations.

NOTES ON PHYSIOLOGY: for the Use of Students Preparing for Examination. By HENRY ASHBY, M.D., Lond. With 134 Woodcuts. New (Fifth) Edition, 1889. Foolscap 8vo., \$1.50.

OLD AND NEW ASTRONOMY. By RICHARD A. PROCTOR. Part VIII. is now ready. Price, 90 cents.

* It is hoped that the remaining parts of this work will be issued at intervals of two months.

A HISTORY OF THE GREAT CIVIL WAR, 1642-1649. By SAMUEL RAWSON GARDNER. (3 vols.) Vol. II. 1644-1647. 8vo., \$8.00. * * * Vol. I. 1642-1644. 8vo., \$7.00.

THE AFTERNOON LANDSCAPE: Poems and Translations. By THOMAS WENTWORTH HIGGINSON. 12mo., cloth, gilt top, \$1.00.

"One of those rare and choice collections of the singer's art, a book to be enjoyed and loved."—*Boston Traveller*.

CIVILIZATION AND PROGRESS. By JOHN BEATTIE CROZIER. New and cheaper edition, 8vo., \$2.00.

"The book is worthy of careful study, and is a genuine contribution to sociological science."—*Popular Science Monthly*.

"The book of a very able man. . . . The testimony which we are compelled to give to the high ability of this ambitious work is completely impartial. . . . Full of original criticism. . . . Great literary faculty. . . . A book far less superficial than Mr. Buckle's."—*Spectator*.

WAR WITH CRIME: being a Selection of Reprinted Papers on Crime, Prison Discipline, etc. By the late T. BARWICK LL. BAKER. Edited by HERBERT PHILLIPS and EDMUND VERNEY. 8vo., \$4.00.

LOST LEADERS. By ANDREW LANG. 12mo., \$1.50.

"We recommend all who delight in the society of a scholar, a gentleman, and a wit, to procure this delightful volume."—*John Bull*.

MICAH CLARKE: His Statement as made to His Three Grandchildren, during the hard Winter of 1734, of the Adventures that befell him during the Western Rebellion. Compiled day by day from his own Narration, by Joseph Clarke. Now for the first time collected, corrected and rearranged from the original manuscripts. By A. CONAN DOYLE. Crown 8vo., \$1.50.

TIMES AND DAYS: being Essays in Romance and History. Foolscap 8vo., \$1.50.

"In this strange little book of many moods there are some prose poems a-throb with an exultant feeling of the passionate beauty of nature. . . . Many of these short papers, consisting of not more than two hundred or three hundred words, embody the essence of a lifetime. . . . and will be welcomed by philosophic, meditative spirits as 'a find' of peculiar value."—*Literary World*.

For sale by all Booksellers. Sent on receipt of price by the Publishers,

LONGMANS, GREEN & CO., 15 East 16th Street, New York.

— Ginn & Co. announce, in the College Series of Greek Authors, "Homer's Odyssey," Books I.-IV., based on the edition of Ameis-Hentze, edited by Professor Perrin of Adelbert College, Cleveland. The German edition has been freely changed to adapt it to the needs of American college-classes, but record is made in the appendix of all important deviations from the opinions of the German editors. References are rather liberally given to the leading American grammars, and also to Monro's "Homeric Grammar." As the gist of matter referred to is always given in the current note, such references are usually meant for those who desire to collect further illustrative material. Much attention has been paid to the indication or citation of *iterati*, conventional phrases, and metrical formulæ. The student should realize in some measure both the bulk of this material and its bearing on the critical analysis of the poem. The latest accepted views in Homeric archaeology are presented. The appendix gives not only strictly critical data, but also material which should enable a student with limited apparatus to understand the historical and literary status of controverted views.

— The latitude of the Detroit Observatory, Ann Arbor, Mich., has been determined by the Zenith telescope, and discussed by the method of least squares, by Ludovic Estes, Ph.D., of the University of Michigan. The results are published in pamphlet form by the author.

— P. Blakiston, Son, & Co., announce that the edition of "The Hygiene of the Nursery," by Louis Starr, M.D., is exhausted. A new edition is in press, and will be published about April 1. The author has taken this opportunity to rewrite certain parts of the work, and to make some additions.

— On or about April 6 will commence the publication of a weekly journal, devoted to the petroleum and natural-gas resources of the whole country, entitled *The Journal of Oil and Gas*. Situated midway between the great gas-fields of Pennsylvania, Ohio, and Indiana, and in the heart of Ohio oil-producing territory, with every facility for the publication of a first-class journal, the publishers (Fremont, O.) will spare no effort to make it the recognized authority on gas and oil matters.

— The admirers of "Little Lord Fauntleroy" will welcome the leading article in this month's *St. Nicholas*, by Mrs. Lillie, telling of little Elsie Leslie Lyde, the child who is now interpreting the character to New York audiences. There is an article meant for boys, and describing with drawings and pictures "Ancient and Modern Artillery," by Lieut. Hamilton, and (to thousands of competitors a most interesting feature) the report awarding prizes in the "King's Move" Puzzle.

LETTERS TO THE EDITOR.

*.*Correspondents are requested to be as brief as possible. The writer's name is in all cases required as proof of good faith.

The editor will be glad to publish any queries consonant with the character of the journal.

Twenty copies of the number containing his communication will be furnished free to any correspondent on request.

The Robinson Anemometer.

IT seems likely that there are now to be some rather interesting developments in regard to the movement of this anemometer. As to the use of an equation for representing the relation between the wind-movement and travel of the cups, I think it a serious waste of labor. Even if we have the equation given in last *Science*, it cannot help us in obtaining the relation till we have solved it, and obtained a table or the figures given in my letter published in *Science* of March 15.

Professor Marvin's explanation of the effect of a uniform wind blowing across a whirler, upon which an anemometer is being tested, is very surprising and entirely untenable. The anemometer is certainly *not* going *with* the wind during one half of its revolution, and *against* it during the other half. Suppose we carry an anemometer on a locomotive due north, and a wind is blowing from the north: the velocity registered by the anemometer will be the sum of the two. But if the wind is from the south, the anemometer will record the difference between the two. If the wind blows either east or west, it will add its effect to the motion of the locomotive. We see, then, that, during less than one-fourth of the

revolution of the whirler, a uniform current will be balanced on opposite sides, but during more than two-fourths of the revolution the uniform current will act continuously in augmenting the anemometer travel; or, in other words, the anemometer will be accelerated during more than three-fourths of the rotation, and retarded during less than one-fourth of it. This also explains why the helioid anemometer used in England did not show variable results, as it had a vane to keep it normal to the wind: the effect of the wind would just be counterbalanced at opposite sides of the whirl, and there would be no acceleration, as in the case of the Robinson anemometer.

Professor Marvin raises an interesting question as to the theoretical behavior of the cups in an intermittent wind. It has generally been considered that while these cups never respond instantly to the wind, and continually lag behind while the wind is rising, yet their momentum keeps them up, and about counterbalances this lagging while the wind dies down. During the experiments with the whirling arm it occurred to me that the wind might have a different effect, and that it was necessary to make the final comparison in the open air.

On March 23 a comparison was made between the regular Signal Service anemometer, weighing sixteen ounces, and one with paper cone-shaped cups of about the same dimensions, and weighing two ounces and a half. The results were very surprising, as the paper cones gave very nearly twenty per cent less velocity than the spherical; also, with the lowest velocity, these cups gave relatively the least wind. On watching the cups, it was plain that this diminution occurred with a uniform wind as well as with an intermittent one. The cups were then weighted with lead to four times their previous weight, and there was no difference in the result, showing that the trouble was with the shape, and not with the lightness of the cups. Paper cups were then made of a spherical form; and these gave almost exactly the same velocity as the metallic cups, though having only one-seventh their weight. It was noticed, that, with the most intermittent wind, the paper cups gave the most increase, amounting in one case to eleven per cent over the metallic. The higher the wind, in general, the more nearly did these cups agree. We may rest satisfied, then, that the heavy metallic anemometer, instead of giving too much wind, really gives too little; and the more gusty the wind, the less the movement recorded by the heavy cups. H. A. HAZEN.

Washington, D.C., March 30.

An Earthquake in Pennsylvania.

IT occurred to me that it might be of interest to the readers of *Science* to know that an earthquake occurred at this place, Lancaster City, Penn., on the 8th of March, at about 6 hours and 40 minutes P.M. This tremor was felt also at Harrisburg, York, Philadelphia, and Reading, as well as at many other places within the community of these places. Never having felt an earthquake-shock myself, it did not at once occur to me that this was really an earthquake, and therefore I did not at once take the time of its occurrence. That evening and the next morning I tried to find persons who did look at their time-pieces at the moment when it occurred in order to find the time as accurately as possible. Altogether, seven persons were found who claim to have looked at their watches when it occurred. Of these, two are quite different from the others, and must be considerably in error. But five of them agree fairly well. I compared each one of those time-pieces with my own, which was compared with the Scholl Observatory clock. Making in this way all possible corrections, the mean of the times was found to be 6 hours 40 $\frac{2}{10}$ minutes P.M., with a probable error of only about two-tenths of a minute. This is 75 Meridian time. If the tremor did not have too high a velocity, and similar observations have been gathered at other places, it may be possible to get an estimate of the velocity and direction of the shock.

The tremor or trembling of the earth, according to my estimate, lasted about ten seconds. A number of persons agree with this estimate. Others, however, insist that it lasted about fifty seconds, as actually noted by the watch. The direction of the tremor seemed to be in a line a little north of west to south of east. Others also give it as north and south. JEFFERSON E. KERSHNER.

Lancaster, Penn., March 26.

Shall We Teach Geology?

PERHAPS Professor Winchell and his reviewer have said as much as is profitable on the points at issue between them, and yet I for one should feel sorry to have the discussion end precisely as "Reviewer" leaves it. We all gladly admit that the Roman Empire is a more interesting object of study than the "old red sandstone;" but how if a study of the "old red sandstone" helps us to understand the Roman Empire, in the first place by giving us a superior method of study, and then by teaching us something about the theatre upon which the Roman and other empires played their parts? And especially how if one is teaching children to whom the Roman Empire is very distant and very dead, while the "old red sandstone" crops out just before the schoolhouse door, and is so attractive and interesting to them that they often ask questions about it? Unquestionably, our national hero, when properly brought before the mind, is a more gracious figure than a plesiosaurus; and yet it is very easy to teach American history in such a way that one form shall seem to the children about as rigid and unstimulating as the other. If a plesiosaurus is just being exhumed in the neighborhood (it is proposed to teach children only the near and the attractive in nature), I am not sure but he will prove, for a few days at least, the more interesting object.

It seems to me that "Reviewer" is afraid of a word. Suppose we say nothing about geology, but simply give the children an opportunity, at proper times and in due measure, to vary their studies by some minute and careful examination of minerals, plants, and animals. Such study need take but little time, but, if properly directed, may be very valuable; may, indeed, exert a transforming influence over those who are subjected to it, giving them new aptitudes, new sensibilities, and a finer organization. Is this too much to ask? Have not twenty-five years of discussion brought us at least as far as this?

What is demanded is not the introduction of a new subject of study into an already crowded curriculum, but an organized course

of nature-study running through the whole period of school-life. The particular objects of study are not so important, but plants and minerals will naturally form in the lower schools the main part of this material. The point is, that the instruction should be continuous enough and yet fresh enough to catch and hold the mind in its varying stages of development from youth to manhood. Good collegiate must be grounded upon good preparatory work. Accepting "Reviewer's" test—that also of Johnson and Arnold—of teaching that which is "interesting to the mass of men," does it bear out his inferences? If so, let us drop this subject altogether, and not cling to the dead form of "geology as an optional study in the high schools and colleges." The ordinary college presents many disheartening sights; but I know of no one more disheartening than to see the members of a senior class who have never taken up a stone except in anger, and never thought of one except as a missile passing from hand to hand,—the *pièces justificatives* of a lecture on geology.

Ypsilanti, Mich., April 1.

E. A. STRONG.

Curves of Literary Style.

It seems necessary to explain occasionally that in the construction of curves of literary style, concerning which two or three notes have recently appeared in *Science*, a very large number of words or sentences must be used. The method is distinctly based on a supposed constancy in the long-run. In the original article the statement is made that probably not less than one hundred thousand words or sentences would be required for the construction of a "characteristic curve." If Mr. Parker had counted only thirty sentences from "Sartor Resartus," he might have found a close agreement with the curve of the "French Revolution," or he might have found a wide divergence. In neither case would the result have had any significance. A comparison of three hundred sentences proves nothing, one way or the other.

M.

Terre Haute, Ind., April 1.

GUARANTY INVESTMENT COMPANY

CAPITAL \$250,000.

Hon. ALBERT H. HORTON (Chief Justice, Kansas Supreme Court), Topeka, Kan., Pres't.

7% Guaranteed Farm Mortgages 7%

The Company calls the special attention of Investors to the following points:

- I. All loans guaranteed and interest payable semi-annually at the Importers' & Traders' National Bank, New York.
- II. Unusual fulness of information, not only about the security itself, but about the general development of the section where the farm is located.
- III. An examination each year of the general business of the Company and the Mortgages themselves by a COMMITTEE OF INVESTORS sent for the purpose.
- IV. Many hundred Mortgages taken and NOT A SINGLE FORECLOSURE.
- V. Exhibitions in New York at frequent intervals, of Kansas and Nebraska Farm Products. The Exhibition at the American Institute in the fall of 1888, received the *HIGHEST AWARD* of superiority.
- VI. Monthly Bulletins giving full information about all Mortgages offered for sale.

Address for Monthly Bulletin and Investors' Committee Report for 1888,

HENRY A. RILEY, General Eastern Manager, 191 Broadway, N. Y.

Schools.

CONNECTICUT, NEW HAVEN, MRS. CADY'S SCHOOL FOR YOUNG LADIES. Prepares for Smith and Wellesley, and admits to Vassar by Certificate. Circulars. Early application necessary.

NEW JERSEY, PLAINFIELD. THE CHESTNUTS.—Parents with daughters to educate, or orphan girls with companion, may find a comfortable home, with school instruction by applying to Miss E. E. Kenyon.

NEW YORK CITY, N. Y. BOTANY, MICROSCOPY.—PRACTICAL courses at the New York College of Pharmacy open for ladies and gentlemen from April to end of June, including botanical excursions and individual instruction in microscopic work. For particulars apply to College, 290-273 East 23d St., or to PROF. J. SCHRENK, Hoboken, N. Y.

VERMONT, BURLINGTON. VERMONT EPISCOPAL INSTITUTE. Boarding School for Boys. Prepares for College or Business. Military drill. Terms moderate. Fifty-seventh half-year opens September 3, 1883. Send for catalogue. H. H. ROSS, A. M., Principal.



GOOD NEWS TO LADIES.

Greatest inducements ever offered. Now's your time to get up orders for our celebrated Teas and Coffees, and secure a beautiful Gold Band or Moss Rose China Tea Set, Dinner Set, Gold Band Moss Rose Toilet Set, Watch, Brass Lamp, or Webster's Dictionary. For full particulars address THE GREAT AMERICAN TEA CO., P. O. Box 233, 61 and 63 Vesey St., New York.

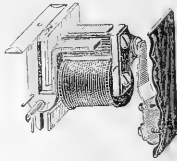

A DROP IN THE PRICE OF

GRAVITY DROP ANNUNCIATORS.

DON'T FORGET THE DUST-PROOF BELLS.

HAZAZER & STANLEY, 32 Frankfort Street, N. Y.

ESTABLISHED 1859. H. A. DREW, Commercial Printer, 5 Clinton Place, near Broadway, New York.

Wedding Orders, Souvenirs, Invitations, Orders of Dance, etc., done in the latest and most elaborate styles, at reasonable prices. All Favors promptly attended to.

16 PAGES. THREE 16 PAGES.

Hundred Thousand new subscribers for The Family Journal and Ladies' Companion wanted. It is the most interesting and instructive paper ever issued. Subscribers will receive during the coming twelve

MONTHS

novels written by American Authors, complete in each three numbers. The story of popular works of fiction will be retold by a novel reader, the most interesting and unique feature introduced in any publication, giving the substance of popular and standard books by famous writers in a space equally read by the busiest people. We have engaged

FOR

this work a widely known and popular writer. Comments on Current Events, Fashions, New and Original Ideas and Designs for Ladies' Fancy Work and Household Decoration. Letters from Correspondents and their Answers. The colleges and seminaries of the United States will be treated one each month in an illustrated article, showing the particular advantage of each, cost of attendance, etc. Invaluable to parents having sons or daughters whom they desire should receive the advantages of a higher education than the ordinary school affords. Articles on Painting and Drawing, giving home instruction by a well-known artist. A trial subscription of this elegant paper will be sent to any address, three months, for

TEN CENTS.

Liberal pay for literary work adapted to our columns, and for new and original drawings, designs and ideas on any subject which we can use.

Premium List the most complete in the world. We offer inducements to club raisers and agents approached by no other publishing house. The celebrated Gilbert Cut Waist Linings, which we send post paid to any one sending us two yearly subscribers at 40 cents each is alone worth 10 cents.

Send to any address, post paid one year, 50 cents; six months, 25 cents, and a three months' trial subscription for only 10 cents.

TRY IT! TRY IT! TRY IT!

and you will become a permanent reader. Address: John L. Douglass, Publisher, 322 Broadway, N. Y.

Any one who will have the following blank filled out by a responsible Newsdealer, and mailed to us, will be allowed a three months' subscription to Science.

N. D. C. HODGES,

47 LAFAYETTE PLACE, NEW YORK.

1889.

To the News Company.

You may add to my regular order five copies of SCIENCE each week (returnable).

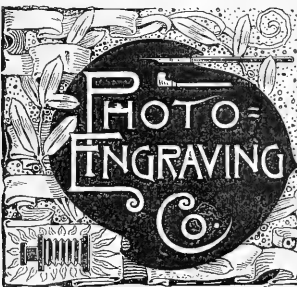

BRANCH AT 728 CHESTNUT ST. PHILADELPHIA, PA.

JOHN HASTINGS = Frest. -A-R-HART- Genl. Manager. -JOS=TRIPP. VPrest.

ENGRAVING FOR ARTS ILLUSTRATIVE AND ADVERTISING PURPOSES

67-71 PARK PLACE NEW YORK

Brokers and Auctioneers.

R. ELLIS & CO.

BUSINESS, HOTEL AND PATENT BROKERS, AUCTIONEERS, ETC.

No. 176 BROADWAY,

Room 46. New York.

CLIENTS ADVISED free of charge.

J. P. TRAYER & CO., General Auctioneers, Real Estate and Business Brokers, OFFICE, 23 PARK ROW, OPPOSITE POST OFFICE, (ROOMS 14 & 15.) New York.

Mortgages Foreclosed. Cash Advanced on Consignments. Property of Every Description Bought, Sold and Exchanged.

C. & C. ELECTRIC MOTOR COMPANY.

Electric Motors
FOR
Arc and Incandescent Circuits, Most Economical Motor on the Market.
Regulation Perfect.
Motors Designed for all Power Purposes.

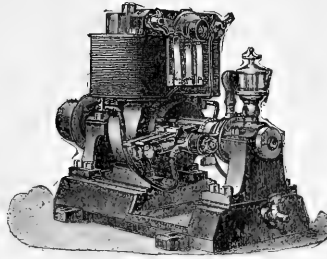

OFFICE and MANUFACTORY:
402 and 404 Greenwich Street, New York City.
New England Office, 19 Pearl St., Boston.
Philadelphia Office, 301 Arch St.
Western Office, 139-141 Adams Street Chicago.
Southern Office, 25 Carondelet Street, New Orleans.

THE

American Bell Telephone COMPANY.

95 MILK ST., BOSTON, MASS.

This Company owns the Letters Patent granted to Alexander Graham Bell, March 7th, 1876, No. 174,465, and January 30, 1877, No. 186,787.

The Transmission of Speech by all known forms of ELECTRIC SPEAKING TELEPHONES infringes the right secured to this Company by the above patents, and renders each individual user of telephones, not furnished by it or its licensees, responsible for such unlawful use, and all the consequences thereof and liable to suit therefor.

ESTERBROOK'S STEEL PENS.

OF SUPERIOR AND STANDARD QUALITY.
Leading Nos.: 048, 14, 130, 135, 239, 333
For Sale by all Stationers.
THE ESTERBROOK STEEL PEN CO.,
Works: Camden, N. J. 26 John St., New York.

Old and Rare Books.

A. S. CLARK, Bookseller,

34 PARK ROW, NEW YORK CITY.
A Gleaner in the By-ways of Literature. Results of Gleaning found in Catalogues issued from time to time.
CATALOGUE NO. 27 NOW READY.

BACK NUMBERS and complete sets of leading Magazines. Rates low. AM. MAG. EXCHANGE, Schoharie, N. Y.

H. WILLIAMS,
Dealer in Old Magazines, Reviews, &c. Scientific periodicals a specialty. 39 Macdougall St., N. Y.

Scientific Apparatus.

J. GRUNOW,

621 Sixth Avenue, New York.
Established 1852.

MAKER OF

Microscope Stands, Oil Immersion Objectives and Abbe Condensers for Bacterial and Histological work, of Objectives, Camera Lucida and other accessory apparatus.

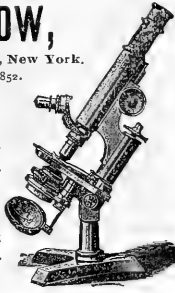

IMPROVED OIL LIGHT MAGIC LANTERNS.

Also Lime and Electric Light Apparatus, and mechanical, plain, and fine colored views.
J. B. COLT & CO., Manufacturers,
No. 16 BEEKMAN STREET, NEW YORK.

MAGIC Stereopticons and the Best Views for Public, Church, Home, and Scientific Exhibitions. Best apparatus, new views. Largest stock. Reduced prices. 24 Years' Practical Experience. Illus. Catalogue Free.

GEO. H. PIERCE,
136 S. Eleventh St., Philadelphia, Pa

ELECTRICAL TESTING BUREAU,

Johns Hopkins University, Baltimore, Md.
Resistance Coils and Boxes Compared.
Am meters and Volt meters calibrated.
Condensers standardized.
Primary and Secondary Batteries Tested.
Efficiency of Dynamios and Motors Determined.
Insulation of Cables and Wires Tested.
Etc., Etc.
Circulars describing Methods Used, Prices, Etc., sent on Application.
Address as above.

MORRIS EARLE & CO. SUCCESSORS TO R. & J. BECK,

1016 Chestnut Street Phila

Microscopes and all Accessories and Apparatus. Photographic and Photo-Micrographic Apparatus and Outfits.

Spectacles, Eye Glasses, Opera and Marine Glasses, etc.
Illustrated Price List mailed free to any address. Mention SCIENCE in corresponding with us.

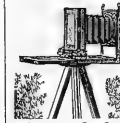
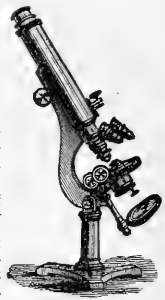

E. & H. T. ANTHONY & CO.
591 Broadway, N. Y.

Manufacturers and Importers of PHOTOGRAPHIC INSTRUMENTS, Apparatus and Supplies of every description. Sole proprietors of the Patent Detective, Fairy, Novel, and Bicycle Cameras, and the Celebrated Stanley Dry Plates.

Amateur Outfits in great variety, from \$5.00 upward. Send for Catalogue or call and examine. 25 Years More than 40 years established in this line of business.

WHITALL'S PLANISPHERES OR DIRECTORY OF THE STARKY HEAVENS name and locate all Stars, Constellations, and Planets visible at any given minute of time. Should be used by every one. Ask your stationer, or address WM. T. COOPER, Manager, 307 Race St., Philadelphia, Pa.

Readers of Science

Corresponding with or visiting Advertisers will confer a great favor by mentioning the paper.

TO EMPLOYERS.

Having purchased the fixtures, good will, &c., of the NEW YORK EMPLOYMENT BUREAU at No. 681 BROADWAY, in this city, we request the patronage of the public in the future. We desire to fill a long-felt want for an employment bureau, where only the best grade of male help is dealt in, and it is our aim to send ONLY such help as is ordered in every instance, and our patrons can rely on us to send strictly first-class help, the references of whom we personally investigate before sending to any one. We simply request a trial, and are convinced that we will give satisfaction in every case. We have on hand help in every branch, which we can send upon receipt of telegram or letter, AND FOR WHICH WE MAKE NO CHARGE TO AN EMPLOYER.

NEW YORK EMPLOYMENT BUREAU,
(AS REORGANIZED).

CALIGRAPH REMINGTON STANDARD TYPEWRITER

MEDAL AWARDED!

GREATEST SPEED ON RECORD!!

126 words per minute, errors excluded.

T. W. Osborne, winner of international contest at Toronto, wrote on the Caligraph Writing Machine 630 words in five minutes, thus gaining for the Caligraph the championship of the world.

30,000
in
Daily Use.

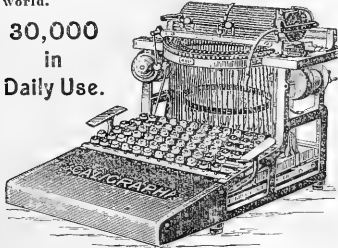

For full and correct account of above test, address
THE AMERICAN WRITING MACHINE CO.,
HARTFORD, CONN.
New York Branch, 237 Broadway.

THE CHEQUE BANK

LIMITED.

ESTABLISHED IN LONDON, 1873.

CHIEF OFFICE, 4 Waterloo Place, Pall Mall, London.

TRUSTEES:

The Right Honorable JOHN BRIGHT, M.P.
The Right Honorable EARL BEAUCAMP.
Bankers: Bank of England.

The Capital of the Bank and its Guarantee Fund of 500 is invested in Government Securities. The Bank does not discount Notes or Bills, nor speculate, but loans its Deposits against Government Securities, thus making the Cheque Bank Cheques EQUAL TO CASH—as Bank of England Notes are.

The Cheque Bank issues Cheques, singly or in books from ONE POUND upwards, for the use of Travelers, and for others remitting money to Europe, available in every town in England, Scotland, Ireland, and Wales. In every town of Europe, and all other parts of the world, Cheque Bank Cheques are accepted as Cash by all the British Government Offices.

VISITORS TO THE PARIS EXHIBITION this summer can get the Cheque Bank Cheques cashed at 50 Banking Houses in Paris.

Travelers and others holding Cheque Bank Cheques can have their mail matter addressed to them, care of the Cheque Bank, London, which will take charge of the same and forward to any address.

For Hand-Book containing List of upwards of 2000 of the principal Banking Houses throughout the World who Cash the Cheque Bank Cheques, and for all information, apply to the AGENCY.

CHEQUE BANK, Limited,
UNITED BANK BUILDING,
2 WALL ST., NEW YORK.

E. J. Mathews & Co., Agents.

REFERENCES BY PERMISSION:

JNO. W. MACKAY, Esq., President Commercial Cable Company, Mackay-Bennett Cables, New York.

F. O. FRENCH, Esq., President Manhattan Trust Co., New York, and others.

FOOD ADULTERATION

And its Detection. With photomicrographic plates and a bibliographical appendix. By J. P. Battershall, 328 pages, 8vo, cloth. Price, \$3.50. Circulars and Catalogues on application. E. & F. N. SPON,
12 Corlandt St., New York.



Gold and Silver Medals

WON
FOR

CHAMPIONSHIP OF THE WORLD.

At Toronto, in open contest, Aug. 13, 1888.

151 Words per Minute, Without an Error.

The above is an authentic record made by Mr. Frank E. McGurrin, at Detroit, on Jan. 21, 1889, on a memorized sentence, thus beating all previous records of correct work, by 30 words per minute and placing the "Remington" still further beyond reach of competition. Photographic copies of certified work furnished on application. WYCKOFF, SEAMANS & BENEDECIT, 327 Broadway, N. Y.

Arnold,
Constable & Co.
SPRING STYLES
DRESS FABRICS.

Plain and Hair-Line Batiste Cloths,
Printed Laines, Fancy Mohairs,
Cheviots, Tweeds,
for Steamer and Traveling Dress.
Checked and Striped Suitings,
Broche and Embroidered Robes,
Cashmeres d'Ecosse, Henrietta Cloths,
IN NEW COLORINGS.
FOR STREET AND EVENING WEAR

Broadway & 19th St.
New York.

Plain and Fancy Flannels

We call attention to our different lines of Flannels for summer wear. **Scotch Striped Flannel, 28 to 50 cts. per yard; Fancy Silk Striped, 65 cts. per yard. 32-inch plain flannel with handsome Side Band, 65 cts.; Figured and Fancy Striped French Flannels, 60 and 65 cts. Plain Opera Twills, 27 inches wide, all shades, 50 cts. per yard. 6-4 Cream Suitings, 65 cts., 75 cts., 85 cts., and \$1 per yard.**

Samples sent on request.

JAMES McCREERY & CO.

BROADWAY AND ELEVENTH ST.,
NEW YORK CITY.

IMPROVING
THE
MEMORY PICK

and facilitating the acquirement of knowledge by lectures and correspondence. Classes forming. "MEMORY and its Doctors," from Simonides to "Loisette," mailed for 10 cents.
DR. PICK, 24 Union Square, N. Y. City.

KNABE
PIANOFORTES.

UNEQUALLED IN

Tone, Touch, Workmanship and Durability.

WILLIAM KNABE & CO.

NEW YORK: No. 112 Fifth Av., above 16th St.
BALTIMORE: Nos. 22 and 24 E. Baltimore St.
WASHINGTON: No. 817 Market Space, Penn. Av., near 9th St.

SPECIAL TEACHER'S EXCURSION TO

PARIS EUROPE
AND THE
WORLD'S EXPOSITION,

visiting England, France, Germany, the Rhine, Belgium and Holland. All travel and hotels 1st CLASS. Finest line of Steamers crossing the Atlantic. Low Rates, Rooms are being rapidly taken. Send for circular, free.
E. TOURJEE, Franklin Square, Boston, Mass.



KIMBALL'S

STRAIGHT CUT

CIGARETTES.

Unsurpassed in quality.

Used by people of refined taste.

Highest award at Brussels, 1888.

The finest smoking mixtures are of our manufacture.

Fifteen First Prize Medals.

WM. S. KIMBALL & CO.

Rochester, N. Y.

Readers of Science

Corresponding or visiting with Advertisers, will confer a great favor by mentioning this paper.

What Scott's Emulsion Has Done!

Over 25 Pounds Gain in Ten Weeks.
Experience of a Prominent Citizen.

THE CALIFORNIA SOCIETY FOR THE
SUPPRESSION OF VICE,
SAN FRANCISCO, JULY 7th, 1886.

I took a severe cold upon my chest and lungs and did not give it proper attention; it developed into bronchitis, and in the fall of the same year I was threatened with consumption. Physicians ordered me to a more congenial climate, and I came to San Francisco. Soon after my arrival I commenced taking Scott's Emulsion of Cod Liver Oil with Hypophosphites regularly three times a day. In ten weeks my avoirdupois went from 155 to 180 pounds and over; the cough meantime ceased. C. R. BENNETT.

SOLD BY ALL DRUGGISTS.

133506
APR 22 1889
NEW YORK LIBRARY

SCIENCE

[Entered at the Post-Office of New York, N. Y., as Second-Class Matter.]

A WEEKLY NEWSPAPER OF ALL THE ARTS AND SCIENCES.

SEVENTH YEAR.
VOL. XIII. No. 323.

NEW YORK, APRIL 12, 1889.

SINGLE COPIES, TEN CENTS.
\$3.50 PER YEAR, IN ADVANCE.

MICHEL EUGENE CHEVREUL.

MICHEL EUGENE CHEVREUL, the distinguished French chemist, died in Paris, April 9. He was born Aug. 31, 1786, in Angers. His father was a well-to-do physician in Angers, professor in the medical faculty, and a talented writer. Old age seems to be hereditary in the family; Chevreur's father having died at ninety-one, and his mother at ninety-three years.

After the revolution the University of Angers was disestablished, a school for chemical and physical studies being put in its place; which school Chevreur attended between the ages of eleven and seventeen. In 1803, Chevreur went to Paris, where his aptitudes were quickly noticed. In 1806 he was appointed director of Vauquelin's laboratory, and professor in the Lycée Charlemagne, and during the same year he published the results of his first experiments. In 1806 seven papers came from his pen, of which three were on coloring-matters (indigo and Brazilian wood). Four years later he was appointed *aide-naturaliste* in the Museum of Natural History, then examiner for the Ecole Polytechnique; and at thirty he was professor of chemistry in the Gobelins, the world-known manufactory of tapestry, and director of the department of tinctorial baths. In 1826, after the death of Proust, Chevreur was appointed member of the Academy of Sciences. Not one of his colleagues of that time is now living. In 1830 he became professor in the museum, and some time after director. He never missed a meeting of the Academy of Sciences up to his one hundredth birthday, and it is not long since one could meet him in the Rue des Ecoles, walking to the Institute, hat in hand, and hands behind the back. He seemed to have an aversion to hats, and dispensed with them a great deal.

During the war of 1870 he remained in Paris. It was in a letter

written during January, 1871, to Abbé Lamazon, in answer to a note of the latter, that Chevreur used for the first time the expression he preferred when speaking of himself, — "the dean of French students."

Chevreur married early, but his wife died more than twenty years ago. His conjugal life was a very quiet and happy one. Chevreur had only one son, a retired magistrate, who died recently. He

himself lived alone in Paris.

As a man, Chevreur had a very pleasant expression, and always greeted strangers or friends in a very hearty fashion. His life was a quiet one, devoted wholly to work and study. He was a rich man, as he spent little, and his income exceeded by a great deal his expenses. A few years ago he sometimes went to balls, and was a favorite with many ladies. He had a humorous turn of mind. Recently, when accepting a new assistant, he exclaimed, "Well, you must be plucky to become my assistant: I have already killed four!" "Killed" is a metaphor, but no more so than it is when used in speaking of a commander who has killed two or three horses; that is, has had them killed under him.

Chevreur's material life was simple; he eat little. Two eggs and a slice of patty were enough for the morning, with some milk and coffee; in the evening, a full plate of soup, a cutlet, and some fruit, some cheese, and only water or beer, no wine at all.

A catalogue of Chevreur's works would be a work in itself. The two most important branches of science studied and developed by Chevreur are the chemistry of fatty substances, and the theory of complementary colors. By his researches in the former of these, Chevreur gave methods for obtaining a number of very important and useful substances, such as stearine, glycerine, etc. Millions have been earned by the application of his methods. A statue of Chevreur was unveiled at the Paris Museum on his hundredth birthday.



M. CHEVREUL, THE FAMOUS FRENCH CHEMIST.

(Died at Paris, April 9, aged 102 years.)

During the war of 1870 he remained in Paris. It was in a letter

THE SMITH ELECTRIC CONDUIT SYSTEM.

THE Smith conduit is an hermetically sealed tube or box, preferably of wood, properly treated by any process calculated to resist moisture and rot, which is laid midway between the rails of any car-track. This conduit or tube contains the electric conductor or supply-wire on its inside bottom surface, insulated from loss by leakage, corrosion, or wear; and its upper or exposed surface is covered with a series of non-magnetizable metallic plates, each about four feet in length, which are screwed down on to strips or sheets of insulating material, and each insulated from its neighbor, so that the surface of the conduit becomes a strip of metal, broken up into sections of not more than four feet each, from which the car, in passing along over its surface, may take off and use a current of electricity, provided they are, for the time being, directly connected with the source of supply at the bottom of the conduit.

This connection is made in the following manner (see cut): At distances of one or two feet apart, movable connecting pieces are attached to the electric conductor, and rest thereon by gravity until such time as they are attracted from above. The car is provided

cars. By the use of large conductors and a current of low tension, the loss by leakage is reduced, and should almost cease to be a factor in our calculations. The inventor claims that from actual experiments he is assured that this loss, even at such points as may be covered by cars, and under unfavorable circumstances, such as heavy rain and flooded streets, cannot exceed two or three per cent.

The conduit, being not over nine inches deep by five in width, can be laid directly on the cross-ties of the ordinary street-railway track without any cutting of timber or alteration whatever, while it may also be carried around sewer man-holes and ordinary street obstructions. In the case of a single-track road, the benefits of this system are obvious, as the conductor may be branched through all switches and turnouts, and no car can be without power, or light at night, at any point on the road.

The company claims, that, under the patents granted March 5, a conduit can be laid down ready for use at not more than one-half the cost of any other underground system.

It is a part of the plan, as covered by patents, that a blower, or exhaust-fan, or combination of both, should be used to keep a con-

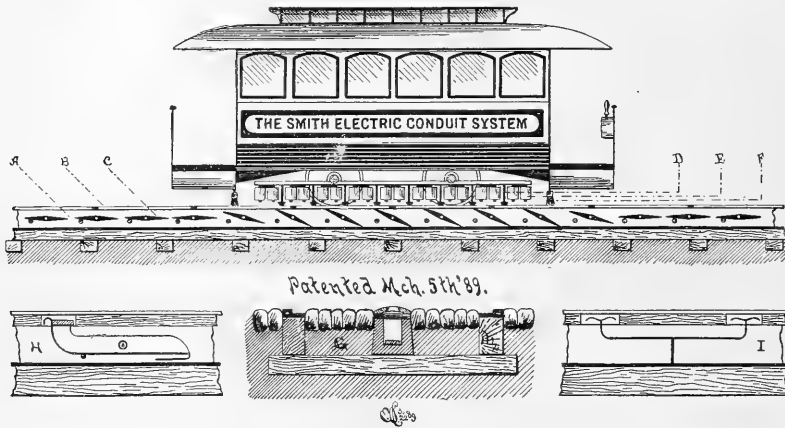

A, longitudinal section of conduit; B, insulated top plates; C, connectors; D, electric brushes; E, electro-magnets under car; F, sweeping brooms; G, vertical section of conduit and track; H, scale-beam connector; I, steel spring or band iron connector.

with a row of magnets on its under surface, which pass along close to the metallic top of the conduit, and, in passing, attract by magnetic influence the connecting pieces before referred to, each of which is provided at one end with a small soft-iron armature. It will thus be seen that as these "connectors" each rises up in its turn through small holes in the top board of the conduit, on touching the lower part of the surface plate, they form a direct electrical connection between the cable and such top plates as the car and its magnets cover; so that such parts of the top plates, and only such parts, are always in electrical connection, and form the medium from which the car in its passage is supplied with its current, and power for its electro-motor. It will be noticed that there is no dependence placed on any one connector, but that the magnets are at all times holding up a number of them, or all which may at any one time be beneath the car; and as these connections are constantly being made ahead of the car in its passage, while at the same time broken behind it, the direct attachment of the motor with its source of supply is never broken, and there is no "sparking" between the contact-pieces and the conductor, and no danger of burning out dynamos or connections.

In this system an underground electric supply is given for use where overhead wires are not desired. As the conduit is hermetically sealed, and without any slot or opening whatever, it cannot catch rain, snow and dirt, etc. Immunity from danger is claimed, as the surface of the conduit is dead, and contains no current of electricity, excepting such portions as are covered by the car or

stant current of air passing through the conduit tube at all times, in order to keep its interior free from moisture of condensation, and all its parts thoroughly insulated. This air-current will also serve to detect leaks caused by damage to the conduit from any cause, and insure its immediate repair.

A "non-magnetic shield," not shown in the cut, covers the magnets, and prevents the picking-up of iron fragments from the surface of the track, and insures the full efficiency of magnet-power for the purposes for which it is intended.

Each car is provided with brooms at either end, to sweep off surface dirt on its passage, and insure good connections to the rubbing or frictional contact of the electrical brushes or shoes which follow, and carry the current to the motor, from which, after having done its work, it passes off to either rail or the ground. The illustration shows the simplest forms of scale-beam levers, used as "connectors," and not necessarily the form preferred in use.

A full investigation as to the merits of the system is invited by Harry W. Smith, the inventor, and the Smith Electric Conduit Company, 120 Broadway, New York.

A COMPOSITE photograph, nearly life-size, of eleven members of the faculty of Washington and Lee University, has been taken upon one sensitive-plate with a total exposure of forty-four seconds, each person receiving an exposure of four seconds. The photographer was Mr. Miley of Lexington, Va.

SNOW-BROOM FOR USE ON ELECTRIC RAILWAYS.

ANTICIPATING the usual New England winter, the Thomson-Houston Company designed a snow-broom (shown in the accompanying cut) for use on the Cambridge division of the West End Street Railway. The truck, which is of the Brill type, and has a five-foot wheel-base, is equipped with a thirty-horse-power motor geared to drive the truck at a speed of twelve miles per hour. The snow-broom is thirty inches in diameter, and set at an angle of forty-five degrees. It is driven by a stationary motor of twenty horse-power, at a speed of one hundred revolutions per minute. But two men are required to operate the broom, the brakes and controlling mechanism being placed in such a position as to render it an easy matter. The broom was used for the first time during

comprised 96,900,000 inhabitants, — an increase of 19,000,000 since 1877; and the states where the metric system was legally admitted in principle, or partially applied, as in the customs (Russia, Turkey, British India), comprised a population of 395,000,000, — an increase of 54,000,000 since 1877.

The metric system is thus legally recognized throughout the civilized world by 794,000,000 people, — an increase of 126,000,000 since 1877. These 794,000,000 represent 60.6 per cent of the population of the civilized world; that is to say, of countries which have a census or an official enumeration of the population. These latter contain 1,311,000,000. China, Japan, and Mexico have different systems, decimal but not metric. They represent a population of 474,000,000. The other civilized nations not comprised in the figures given above have neither the decimal nor the metric system.

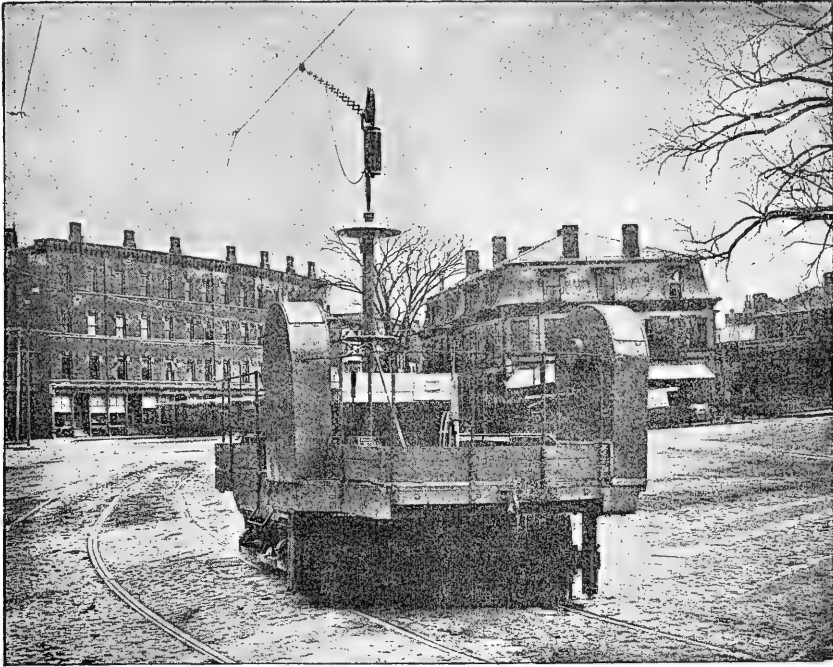

THE THOMSON-HOUSTON SNOW-SWEEPER.

the snow-storm of March 31, and performed admirably; and it was also tested by placing bricks and boards in front of it, and the way these were brushed aside to a distance of four or five feet from the track leaves no doubt of the ability of this appliance to cope successfully with heavy storms. The company has also built a much larger machine, with thirty-six-inch wheels, and fitted with two brooms and a scraper, which will be able to deal with the severest storms.

THE EXTENSION OF THE METRIC SYSTEM.

THE question whether the employment of the metric system is growing or not, was recently discussed in a note presented to the Académie des Sciences by M. de Malarce. An abstract of this appears in "Publications of the American Statistical Association," New Series, No. 4.

M. de Malarce begins by stating that in 1887 the states where the decimal metric system was obligatory comprised a population of 302,000,000 inhabitants, — an increase of 53,000,000 since 1877; the states where the metric system was authorized by law as optional (England, certain British colonies, Canada, the United States)

They represent but a slight fraction of the civilized world, — less than 43,000,000.

If we pass to the examination of monetary systems, it will be noticed that the five states that formed the monetary union of 1865 — France and her colonies, Belgium, Italy, Switzerland, and Greece — comprise a population of 111,000,000. Four states — Austro-Hungary (since 1870), Monaco (1879), Finland (1878), Russia (1887) — coined certain pieces in conformity with the French system, which are receivable, according to a decision of the French Government, at her public banks, and in consequence are legal tender in France. These states represent a population of 144,000,000.

Four states in Europe, — Roumania (1867), Spain (1868), Servia (1873), and Bulgaria (1877), — one state in Africa, — Kongo (1877), — one state in Asia, — Persia, — and nine states in America, — the Argentine Republic, Bolivia, Chili, Columbia, Hayti, Nicaragua, Peru, Uruguay, and Venezuela, — have also coined money according to the French system; and these represent a population of 56,000,000. The total population, therefore, of the states which have coined money similar to the French system, comprise 311,-

000,000 as against 162,000,000 in 1877. These 311,000,000 equal 23.7 per cent of the population of the civilized world.

Besides these states which tend to the French monetary system, and to an international circulation, there are certain notable exceptions; as, for example, England, Canada, Germany, the Netherlands, Scandinavian Union, Turkey, Morocco, Portugal, China, Siam, Japan, the United States, and Brazil.

EXCAVATIONS FACILITATED BY FREEZING.

ABOUT seven years ago Mr. Herman Pöetsch of Aschersleben, Germany, conceived the idea that excavations through difficult ground could be facilitated by freezing it by means of cold brine circulated through pipes inserted down to rock or impervious

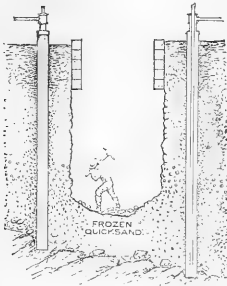

FIG. 1.

material; these ground-pipes being perfectly closed at the lower end, and containing a smaller pipe open at the lower end, down which the brine is pumped, rising in the outer pipe, and returning to an ice-machine to be cooled again.

After some experiments made with a small apparatus, which were so far satisfactory as to make it evident that the process was a success, he undertook the completion of a shaft partially sunk at the Archibald Mine, near Schweidlingen, Germany, which resulting successfully has induced its application in many coal-fields

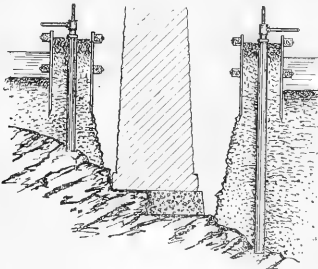

FIG. 2.

throughout Germany, France, and the Netherlands. There was much need, in Germany especially, of some way of getting to the beds of lignite and coal, of which there are many covered with beds of quicksand that are almost impassable. This process has added materially to the area of available coal-fields. The greatest depth yet reached in this way through water-bearing strata is 250 feet, although there is no limit to the depth capable of being reached; and there has been no failure to accomplish the work undertaken.

Fig. 1 shows a shaft being dug and partially timbered up. In practice it is usual to place pipes about 8 inches in diameter, and about 3½ feet apart, in a circle around the space to be excavated. It is of great importance that the pipes be perfectly closed, and

that they extend not only to the rock, but far enough into it to allow any surface fissures to be frozen, thus preventing as far as possible percolation through the ledge.

Fig. 2 shows the process applied to an excavation for a bridge-pier, the frozen wall surrounding the excavated space being in effect a coffer-dam. By its application in this way, the last difficulty is removed in the way of bridging the great rivers having deep alluvial beds, where the depth to rock is so great as to preclude pneumatic foundations; i.e., greater than one hundred feet below the water surface.

It has been applied once to tunnelling. In digging under a hill occupied by residences in Stockholm, it was feared that the movements of the ground would cause the buildings to settle and crack. The inner end of the tunnel was formed into a freezing-chamber, and cold air at a temperature of -67° F. was circulated through it, which effectually hardened the sand to a depth of five feet from the surface, making a material resembling sandstone rock. The freezing was continued ten or twelve hours, and then excavation and walling-up proceeded with for the same length of time. About one foot per day was made in this manner. It is often desired to make excavations in this way adjacent to or under buildings where there is danger of undermining the foundations.

The owners of the American patents, The Pöetsch-Soosmith Freezing Company of New York, have made several improvements in its application to tunnels especially. The first application of the freezing process in this country was in digging a shaft for the Chapin Mining Company at Iron Mountain, Michigan, where a rectangular shaft 15½ feet by 16½ feet in the clear, and 95 feet deep to the ledge, was sunk through quicksand and bowlders. Twenty-six 8-inch pipes closed at the lower end were sunk to the ledge in a circle 29 feet in diameter; and a Linde machine, having a refrigerating capacity of fifty tons of ice per day, cooled the brine. This work was very successful, the ledge being reached in seventy days after the ice-machine was started. A shaft at Wyoming, Penn., is now being constructed in the same way.

THE LIGNITE INDUSTRY IN GERMANY.

AMONG the number of new industries which are making their way in the world, the manufacture of briquettes from the brown coal or lignite deposits in Germany is one which has of late made considerable strides. This process is well described in *Engineering* of March 22. Up to within the last ten or fifteen years, these tertiary deposits of lignite, or half-formed coal, were not utilized in commerce, and were only worked in a small way by the local peasants for consumption in their cottages. Even this small trade almost died out with the introduction of cheap coal, due to the extension of the railway system, as, owing to the fifty per cent of moisture which the lignite contained, it was impossible for it to stand transport or to compete with coal.

The beds of lignite in Saxony, and on both banks of the Rhine near Cologne, are from ten to twenty yards thick; and, as they are only covered by from five to ten yards of gravel, they are easily worked in the open as quarries, the gravel being removed and used for filling up as the working of the lignite advances. The lignite is of a dark-chocolate color, and, as its consistency is about that of cheese, it can be easily and cheaply worked by means of the pick and shovel.

Near the surface it contains slightly more moisture; but, taking an average of the whole thickness, it amounts to about fifty per cent. The decomposition of the wood is not in all places perfect; and stumps, roots, branches, and trunks of trees are sometimes met with. When these occur too frequently, the lignite is not so well adapted for making briquettes, as, owing to the wood being of a still fibrous nature, it cannot be so readily reduced to powder, which is absolutely necessary for its manufacture into fuel, though of course these remains of trees can be burnt as ordinary wood, and are indeed so utilized. As a rule, however, the mass of the bed is friable, and can easily be crushed in the hand.

With regard to the formation of these deposits, there are in Germany two theories. The one is that these masses of lignite were formed in precisely the same manner as the coal-seams, but

that they have not undergone the pressure to which the coal-beds were subjected, although, as in the case of the coal, the wood of which they were formed grew on the spot now occupied by the beds or seams. The other theory is, that the wood was washed down by the rivers from mountainous forest regions, and deposited in quiet bays of the river, where it finally decomposed, and formed the lignite of to-day.

The following are various analyses of lignite in its manufactured form, having been dried and pressed by machinery, but without the addition of any foreign matter. Indeed, such is never added, nor is it necessary, the lignite containing within itself all the properties necessary for making it into a cleanly, cheap, and efficient combustible. The similarity of these lignite briquettes to wood as regards their heating effects, and the ashes left, will be noticed in the analyses.

Analyses of Lignite Briquettes.¹

Date.	Mine.	Moisture.	Ash.	Number of Grams of Water to be set to One Gram of Lignite.	Centigrade Heat Units per Gram.
March 16, 1887.....	Fishbach	18.66	4.9	18.1	4235
" 21, 1887.	Rottgen	17.6	6.2	16.9	3954.6
" 21, 1887.....	Brühl	13.6	5.4	18.6	4352.4
" 21, 1887.....	Rodder Grube	14.6	5.4	17.9	4186

Owing to the great thickness of the bed, the working expenses are very low; and, when worked in the open, the raw material can be delivered at the works for seven pence per ton. No explosives are necessary, and as a rule the lignite is loaded direct at the working faces into the wagons of a wire-roped railway, which convey it to the mill.

In some cases, as at Honern, near Cologne, the workings are all under ground, owing to the great thickness of the layer of gravel which covers the lignite. The method pursued in these cases for working the lignite is precisely similar to the "pillar and stall" system adopted in collieries. Great chambers are cut in the lignite, and supporting pillars are left. The proportion which can be extracted by this means is about two-thirds of the mass. The surface of the ground above the workings sinks and cracks, and has to be made good, even at considerable cost; so that, whenever possible, the open system should be adopted.

The lignite rests in some cases upon a bed of pure bluish-white clay, as at Kalscheuren, and in others upon a bed of white sand. In either case the material is utilized. The clay makes beautiful white ornamental bricks and piping, while the sand finds a ready sale for a multitude of purposes. At Herzengorath the lignite rests upon this bed of sand, the sand itself being occasionally hard, and in thin beds of friable sandstone. At this mine the concession is surrounded by the collieries of the Aix-la-Chapelle basin; but as the uses for the two kinds of fuel, coal and lignite, are so different, the competition is not dreaded, the more especially as the coal cannot be burned in the stoves as at present used for burning wood; and it is as a substitute for wood, which is largely used as fuel on the Continent, that briquettes of lignite find especial favor.

The great difficulty which stood in the way of the utilization of the raw lignite consisted in the necessity for rapidly and economically driving off the excess of water it contained, and in doing this in such a manner that the quantity left could be easily controlled and regulated. Absolute dryness is by no means necessary, nor is it aimed at, and for the following reason. The lignite, like the wood of which it is composed, contains a certain amount of resinous matter; and the secret of the compressing of lignite into briquettes, and of their cohesion in that form, is this very resin

which is contained in it. The pressure to which the lignite is subjected in order to form it into briquettes is enormous, and at the moment of compression it develops very considerable heat; so much so, that the hand can barely support the temperature of a newly formed briquette. Supposing for a moment that absolutely dry lignite were fed into the press, as indeed was first done: the result would be that the heat developed would be so intense as to carbonize the resin, and the briquette would have no consistency or solidity, but would crumble to pieces.

In order to obviate this, numerous series of experiments have proved that the lignite, as it enters the press, must contain eighteen per cent of water, and that this amount of water is sufficient to so modify the heat as to prevent the carbonization of the natural resin, allowing the resin to attain to a sticky state only. This, combined with the force of the blow, forms a solid briquette with a polished surface, which does not soil the hands, and which is not easily broken. A constant stream of cold water is kept in circulation around the press, so as to cool it as much as possible. The briquettes, as they leave the machine, are steaming; and the blow given to the succeeding briquette is utilized to impel those which have preceded it, straight into the railway-wagons, along channels formed of wood, but having at the bottom two iron rails to diminish the friction. By this means hand-labor is avoided for the transport, and the lignite is not touched from the time it enters the mill in the raw state until it enters the railway-wagon and is sent off to the consumer.

The briquette industry is increasing from year to year, the existing works are putting up additional presses to increase their output in accordance with their increased orders, while one or two new companies have recently started, and are in a fair way to success.

THE CHINCH-BUG IN ILLINOIS.

THE economic entomology of Illinois has been distinguished, during the last four years, by the longest period of continuous chinch-bug devastation known in the history of that insect; but, as evidences of the disappearance of this outbreak began to accumulate last fall, it is perhaps not too soon to write its history.

Mr. S. A. Forbes, the State entomologist, states that its beginnings were apparent in 1885, when noticeable injuries to corn were reported from ten counties of southern Illinois; in 1886, thirty counties of that region were seriously damaged, Washington County (about the centre of destruction) being perhaps worst infested; in 1887 the loss was severe in thirty-eight counties of the southern district, and very noticeable in thirty-seven others of northern and western Illinois; while in 1888 small grain and corn were heavily infested throughout all the southern counties, favorable weather alone enabling the crops to withstand the injury better than the year preceding. The attack was now considerably diminished in the centre of the affected area; but farther to the east, in Clay, Richland, and Crawford Counties, it was much heavier in the beginning of the season than the preceding year, its force decreasing, however, with the disappearance of the first generation. On the extreme southern borders of the State, on the other hand, it continued with undiminished severity, the damage done in 1888 being greater than that in 1887,—greater in Pope and Pulaski Counties than ever before since their settlement. There was thus apparent a wave-like propagation outward from the centre above mentioned, the crest of the wave of increase requiring two years to pass from Washington County to the Ohio River. A similar gradual increase northward was demonstrated by a comparison of the numbers of chinch-bugs in the early spring of 1887 with those of the summer and fall, in the counties of Montgomery, Christian, and Shelby.

The recent wide-spread appearance of three destructive contagious diseases of the chinch-bug, and a consequent diminution of its numbers, make it seem at last unlikely that any extraordinary loss will follow this year in the territory which has been so long infested.

From the observations and studies reported, it appears that severe drought in the middle and latter part of the summer may diminish the number of the chinch-bug by lessening the food-supply

¹ The analyses were made by a qualified chemist of Cologne.

of the generations then breeding and hatching, and may operate also to protect the crops of the following year, at a distance from woodlands, by driving the adult chinch-bugs from the open fields, and compelling them to resort to the grassy woods for food for themselves and their young.

Severe drought in a small-grain district has so thoroughly and so early destroyed the corn-crop there, as to test practically the effect of abandoning that crop as a defence against the chinch-bug. In the case observed it was found that the injury the following season was very much less than before. As the drought took effect, however, on the field-grasses generally, and thus still further reduced the supply of insect-food, the result was not to be attributed wholly to a lack of corn.

A similar destruction of the corn by drought in midsummer, followed by a general winter-killing of wheat, has shown that a successive abandonment of these crops may greatly reduce the numbers of the chinch-bug, even where other conditions are very favorable to it; this reduction amounting, in one such case, to one-half or three-fourths of the number abroad the year preceding.

Where wheat is abundant in a district very badly infested by chinch-bugs, it is now certain that this insect may live and breed very successfully in early spring in oats, in young timothy and bluegrass meadows, and even in corn.

A thoroughgoing investigation of the relations of chinch-bug injury to the acreage of the principal farm-crops of Illinois in 1886 and 1887 shows, that, where the outbreak was but just beginning, the wheat area had evidently much to do with the number and the rate of increase of the insects; a rising gradation of injury appearing in correspondence to an enlarging area in wheat, the acreage of the other crops at the same time remaining nearly constant or slightly declining. As the severity of the attack increases, however, the oats area begins to rise with the wheat, and may presently surpass the latter as a stimulus to the multiplication of the chinch-bug, corn and grass finally showing a like tendency where it has become excessively abundant and destructive. Here, when the eggs of the winter brood are being laid freely on all the food-plants of the species, the wheat area may even decline as one passes from districts where destruction is very great to those in which it is complete. This may be due to one or more of the following circumstances: (1) the wheat area may be purposely diminished by the farmers one year after another, as was certainly sometimes the case in southern Illinois in 1887, where chinch-bug injury had greatly lessened the yield and value of the crop for the season or two preceding; (2) a change of feeding-habits may arise among the insects themselves; or (3) there may be a spontaneous gradual shifting of the centre of attack, due to a natural diminution in the number of insects one year in places where they were the year before the most abundant, and an increase in places where they were then less numerous. This territorial propagation outward from a centre of first excess is accompanied by a diminution in numbers in the principal area of origin; and a similar propagation from districts where the crop most preferred and first infested (wheat) is most abundant, to adjacent districts where the leading crops are those freely fed upon, but less preferred (oats, grass, etc.), is also highly probable, but less easily demonstrated. In both cases the diminution in numbers is doubtless largely due to the direct and indirect consequences of over-crowding,—a condition which always arouses or intensifies the action of the natural checks on excessive increase.

Further comparison of the crop areas of 1886 with the injuries of 1887 shows that a very decided diminution of the corn area has had little or no effect to diminish the loss to small grain the following year.

From this we learn that the proper procedure respecting the grass and the cereal crops in the presence of a chinch-bug uprising is the prompt and early abandonment of wheat or a decided limitation of its area, to be followed presently, if the attack continues, by a diminution of the oats acreage also, and the sowing of clover, whenever practicable, instead of the grass forage-plants. We also find that these measures must be taken early or not at all; since, if too long postponed, they may easily do more harm than good.

An analysis of the published opinions of economic entomologists shows a general and rather indiscriminate dependence on the aban-

donment of wheat-culture as a defence against the chinch-bug; this opinion being more positive, however, among the older entomologists than among those who have studied the question recently. A similar indiscriminate but not unanimous opinion as to the advantage of the abandonment of wheat appears in the statements of two hundred agricultural correspondents of the office, eighty-seven per cent of the replies to an inquiry touching this matter being in the affirmative.

From the miscellaneous experiments reported, it appears that the worst-infested fields of small grain may be sustained under a chinch-bug attack by heavy fertilization, if the land be originally in good condition; and that, in general, the damage done will vary inversely to the fertility of the soil and the support given by fertilizers to the crop attacked. The best fertilizers for this purpose, on the wheat-lands of the central part of southern Illinois, seem to be, first, barn-yard manure; and, second, the phosphates and nitrates combined.

The kerosene emulsion, whose deadly effect on the chinch-bug was first shown by Mr. Forbes in 1882, has repeatedly proven a very valuable agent in the hands of farmers when applied in the field for the protection of corn; but it may best be used in combination with some obstruction to the passage of the chinch-bug from small grain and grass to corn,—either ditches and furrows, or belts of coal-tar along the border of the field. A mixture of coal-tar with oil or grease, ten parts to one, will last, without hardening in the sun, from five to ten times as long as the pure tar, but is too fluid to be poured directly on the ground.

Tobacco-water was found frequently fatal to chinch-bugs of all ages, but was apparently less effective than the kerosene emulsion. An emulsion of coal-tar likewise gave promise of usefulness, having the advantage in cost over the kerosene mixture, but being somewhat less convenient of application.

On the other hand, infusion of lobelia, coal-tar water, turpentine emulsion, lime-water, fresh gas-lime, arsenic, London purple, Paris green, the "Egyptian insecticide," buhach, corrosive sublimate, and steam, were applied to chinch-bugs with discouraging results.

Some starvation experiments not begun until Sept. 4 were unsatisfactory, because of the lateness of the period, and because most of the bugs from the district where the specimens used were collected, proved to be already weakened by disease. Adults and young, some just hatched, confined on a dry surface and without food, died in from one to six days. Other young, taken as they hatched, lived from twelve to twenty-four hours.

Careful studies of the contagious diseases of chinch-bugs, revealed in August and September, 1888, the presence of three distinct forms of fungous disease, two of them identical with those reported by Mr. Forbes in 1882, and the third new. All these were widely distributed through southern Illinois, with the possible exception of the region bordering the Ohio River.

Two of these diseases are produced by thread fungi (*Entomophthora* and *Botrytis*), which make a rapid external growth after the death of the insect, presently embedding the body in a snow-white mould; and the third is a bacterial disease, characterized by a minute bacillus, which has its principal seat in the cœca (not the Malpighian tubules) of the alimentary canal. Many and various culture experiments with the latter were completely successful; but infection experiments could not be made for want of specimens originally free from disease. On the other hand, culture experiments with the *Entomophthora* and *Botrytis* were tried without success.

Among various miscellaneous notes, Mr. Forbes reports the failure of an attempt to force the chinch-bug to feed on wild buckwheat (*Polygonum dumetorum*); the very early occurrence of the chinch-bug in Edwards County, Ill. (in 1823, and again in 1828); the prostration of wheat and corn as an effect of chinch-bug injury, due to failure of development of the latest circle of "brace roots;" the harmlessness and uselessness of the flea negro bug, often found associated with the chinch-bug in wheat; the place and time of deposition of the eggs for the second brood; the protective value, under certain circumstances, of the sowing of timothy with wheat in the fall; the successful defence of corn-fields by ploughing and ditching against an invasion from small grain; and an important modification of the mode of destruction by burning in the spring.

THE WAGNER REGULATOR.

THIS electric regulator, invented by Mr. Frank C. Wagner of Ann Arbor, Mich., consists essentially of a high-resistance wire stretched tightly between two supports, and carrying a weight at its middle. The actuating current passes through this wire, which is selected in such a manner as to heat thereby, thus allowing the weight to descend a fixed amount for each strength of current. The weight carries a bar adapted to make contact successively with a number of spring contact-pieces, which are in electrical connection with a number of resistance-coils so arranged as to shunt varying portions of current around the device requiring regulation.

The field for the application of this form of regulator is very wide. Up to the present time, it has been applied practically to only two cases. The first was to compensate for extreme variations of speed in an incandescent dynamo. The wire of the regulator was placed in series with an incandescent lamp fed from the main conductors. Any increase of voltage due to an increase of speed immediately increased the expansion of the wire, thus dropping the weight, and throwing additional resistance into the field-circuit of the dynamo. Before the application of the regulator, lamps were being burnt out continually by sudden increase of speed. This regulator, although very crudely made, has been in use for nearly a year, and with excellent results.

The second application is in connection with an electric meter, also invented by Mr. Wagner. This meter uses the heating action of the current for the actuating force, and in consequence the direct readings are proportional more nearly to the square of the current than to the current itself. The regulator is employed to shunt such portions of the entire current around the meter proper as will render its readings directly proportional to the current strength.

There are many other ways in which the regulator can be applied, especially in connection with alternating currents. Its extreme simplicity, and the very small amount of energy consumed, are great in its favor.

HEALTH MATTERS.

The Hughes Crematory.

THE city of Savannah, Ga., is soon to have a crematory for the destruction of garbage by fire. The model selected is that known as the Hughes Crematory, and is thus described by the *Savannah News* :—

The crematory will be about 30 feet long, and from 15 to 20 feet wide. The main body of the kiln or furnace is a vertical shaft built of brick. At its base will be two hydrocarbon-burners. Upper and lower triangular flues extend across the middle of the shaft, and also an upper and lower set of baffles or side-wings, which are connected by means of wall passages or flues. Underneath these is a shelf, forming a retort in which air may mix with the flames from the burners. Flues are provided for the return of the gases arising from the incineration to a smoke-stack at the side of the shaft. A hydrocarbon-burner is placed at the bottom of the shaft conveying the gases to the chimney, which deodorizes them before they pass out into the air. Perforated steam-pipes are located over the top drop-shelf of the shaft, connecting the burner with the boiler, so that the fluids may be carried off.

The operation of the crematory is simple. When the furnace is brought to the required degree of heat, a load of the material to be burned is emptied into the top of the shaft. It falls on the first drop-shelf. After a suitable period this shelf is dropped, and the mass of material is allowed to fall on the second shelf, and a second is dumped into the kiln. After another interval the second drop-grate is allowed to fall, and the material is thrown upon the baffles and flues below, whence the residuum finally drops down into the ash-pit at the bottom of the shaft. The capacity of the crematory will be 50 tons of garbage per day, and the cost of the process is from 18 to 20 cents per ton.

In Montreal it costs just \$43,000 to destroy by fire a year's miscellaneous refuse, and \$8,000 additional for the burning of its night-soil. The destruction of the latter costs 75 cents per ton, and of the former 25 cents per ton. In Minneapolis it is estimated that 15 to 20 cents per ton of refuse pays for the labor employed and the fuel used. Within five days recently the refuse cremated consisted

of 33 horses, 59 hogs, 103 barrels of hotel and commission-house refuse, 12 loads of market offal, and 70 loads of manure. The aggregate weight was 200 tons, but the ashes deposited in the course of consumption weighed considerably less than 1,000 pounds. The total cost of labor and fuel for this five days' period was \$38.25.

THE MORPHINE HABIT. — Erlenmeyer says that children born of women addicted to the morphine habit are practically morphine-eaters from birth. During the first few days of life, unless morphine is given to them, they are very apt to suffer collapse; and this condition may end in death, the child being too weak to withstand the violent symptoms, which are similar to those which follow the sudden withdrawal of the drug in adult opium-eaters.

SCHOOLROOM SPACE. — Mr. H. Courthope Bowen, whose opinions on all matters connected with the proper construction of schoolrooms are entitled to great weight, and are regarded as authority by the leading medical journal of England, expresses somewhat as follows what, in his judgment, should be considered a good schoolroom. Taking the case of a room 14 feet high, fairly ventilated and always well aired in recess, he would assign two thirds of the floor-space to the scholars and their desks, and keep the other third for the teacher, the blackboard, etc. With single desks, 22 inches should be allowed from side to side, and 3 feet from back to front, for each scholar. The passages need not be more than 18 inches for those running from back to front, and 1 foot for those running from side to side. In such arrangement, counting the passages, each scholar has (without reckoning the share of the space allotted to the teacher) a trifle more than 40 inches from side to side, and just 4 feet from back to front. In a room 25 feet by 20 feet the floor-space for scholars' desks will be 16 feet by 20 feet, with 4 feet from back to front per row, and accommodation is provided for twenty scholars. The whole floor-space is 500 square feet, and the cubic contents of the room 7,000 cubic feet, with 20 square feet and 280 cubic feet per person.

SULPHUR FUMIGATION. — Fumigation by the burning of sulphur is the most common method employed by boards of health in the disinfection of apartments in which contagious disease has existed, and the clothing worn by the patients during their illness. In an address delivered by the distinguished chemist, Dr. E. R. Squibb, before the Kings County Medical Association, he called attention to the fact that there must always be an abundance of watery vapor in the room to be disinfected; otherwise the sulphurous-acid gas generated by the burning of the sulphur is not an efficient disinfectant. The same is true of chlorine gas when used for disinfecting purposes.

DRIED POTATO. — In the *Voënnö-Sanitärnois Dëlo*, Dr. Jakov M. Shmulevitch emphatically draws attention to dried potato as an important food-article, possessing some very valuable advantages in comparison with the vegetable in fresh state. The advantages claimed for the article are these: (1) while fresh potatoes easily rot, blacken, and sprout, dried potatoes, when kept duly protected from moisture, remain in the best condition for a very long time; and (2), being by far lighter and less bulky than fresh potatoes, are by far more convenient for preservation and transportation, which point has a great practical importance, especially in time of war. To be fit for culinary use, the article requires a preliminary maceration in water for about ten or twelve hours.

SPONTANEOUS COMBUSTION. — The following case of spontaneous combustion is reported in the *British Medical Journal* by Dr. Booth: "On the morning of Sunday, Feb. 19, I was sent for to examine the remains of a man, aged 65, a pensioner of notoriously intemperate habits. I found the charred remains of the man reclining against the stone wall of the hay-loft. The main effects of combustion were limited to the corpse, and only a small piece of the adjacent flooring and the woodwork immediately above the man's head had suffered. The body was almost a cinder, yet retained the form of the face and figure so well that those who had known him in life could readily recognize him. Both hands and the right foot had been burnt off, and had fallen through the floor into the stable below, among the ashes; and the charred and calcined ends of the right radius and ulna, the left humerus, and the

right tibia and fibula, were exposed to view. The hair and scalp were burnt off the forehead, exposing the bare and calcined skull. The tissues of the face were represented by a greasy cinder, retaining the cast of the features, and the incinerated mustache still gave the wonted military expression to the old soldier. The soft tissues were almost entirely consumed. On my return from other work, later on, I found that the whole had been removed. The bearers told me that the whole body had collapsed when they had tried to move it *en masse*. From the comfortable recumbent attitude of the body, it was evident that there had been no death-struggle, and that, stupefied with all the whiskey within and the smoke without, the man had expired without suffering, and the body burning away quietly all the time."

THE SUPPRESSION OF SMALL-POX.—An outbreak of small-pox is reported to have occurred recently in Minneapolis, and the health-officer of that city is credited with having summarily and successfully dealt with it. According to *The Journal of the American Medical Association*, as soon as a case was announced, a consultation was called to determine if the disease was small-pox. That being settled, the patient was removed to the quarantine hospital for treatment. The house where he lived was quarantined, and all the people directly exposed were confined in it. Dr. Kilvington's assistants then began to look up all people indirectly exposed, and vaccinated them. Quarantine houses had guards stationed about them, who allowed no one to go in or out during the season of quarantine. The quarantine people were vaccinated, and during the time until it could be determined whether the vaccination would take, they were supplied with food. When the vaccination took, the person under quarantine was bathed, given new clothing in the place of the old, which was burned, and he was then discharged. When a house had been emptied of people under quarantine, the bedding and curtains were burned, sulphur burned in all the rooms, and the walls sprayed with corrosive sublimate. None of the inspectors or guards were allowed to enter any of the houses under quarantine, when there was danger; and the doctors that did the vaccinating saturated their clothing with the corrosive sublimate before and after entering a house where there had been small-pox. The clothing and bedding were either paid for at a reasonable price by the board of health, or were replaced by new articles. In one of the houses quarantined, there were 31 laboring men who were inclined to object to the rules of quarantine. One escaped, but he was taken back when found, and a guard, with a rifle and instructions to shoot should he attempt to escape, was put over him. Since Jan. 13, six thousand people have been vaccinated, and the schools, public and private, have been systematically visited, and unvaccinated children vaccinated. The absurdity of saturating the clothing of the vaccinators before and after entering each house where there had been small-pox is self-evident. Nor do we believe that in this enlightened age any guard would be instructed by a health-officer to shoot a laboring man who, after being shut up forcibly in a house where a case of small-pox had been, should attempt to escape, especially when the house had been disinfected, and the man himself vaccinated. The account above given must, we think, have been obtained from some source outside the health-office of Minneapolis.

ELECTRICAL NEWS.

Canal-Boat Propulsion.

A PAPER read by Mr. H. C. Vogt at the last meeting of the British Association for the Advancement of Science brought out some interesting and remarkable facts. It gave the results of some experiments made with air-propellers at Copenhagen. A steam-launch was fitted with a windmill with steel blades, carried on a frame above the deck, and provided with steam machinery to rotate it. The *London Electrical Review*, in describing the experiment and suggesting a modification of the method, says that at first sight the method would seem an extremely inefficient one as regards application of power to so unstable a medium as the air; but when it is remembered that recent investigations of the marine propeller have established it as a true re-action engine, in which a large slip is not necessarily an accompaniment of inefficiency, it will ap-

pear that there is nothing wrong in the principle indicated by Mr. Vogt. An air-propeller is a pure momentum or re-action machine. Practically it was found that a twenty-foot launch of five and a half feet beam could be driven at a speed of five knots per hour in calm weather, and against a fresh breeze at four knots. The engine producing this effect indicated one and one-half horse-power. For a single indicated horse-power, the thrust of the propeller was 36.7 pounds, or about the same as a water-propeller. It might be supposed that in a contrary wind this thrust would disappear; but, on the contrary, through 75 per cent of the horizon the thrust was found to be augmented by the wind. With a larger launch, having a displacement of five tons, a speed of over six knots an hour was obtained, against the wind. In some of the trials, canvas-covered wings were used, but they were found inferior to steel.

To replace the steam-engine used in these experiments, the *Review* suggests an air-propeller carried well above the decks on a standard, driven by an electric motor which is carried on top of the frame, supplied with current from a wire running along the canal, and connected with the motor through flexible conductors and a carriage travelling on the main wire. The blades of the propeller should be of steel, accurately shaped, and arranged to be turned at a greater or less angle according to the direction of the wind. Thus equipped, a canal-boat could make her way with a speed exceeding that generally used, and with no greater proportionate expenditure of power than that existing in all cases where the trolley system of actuating electric motors is in use.

The advantages of the system are obvious. The hull of the vessel would be entirely clear of machinery, and the entire weight of the propelling apparatus carried by the boat need not exceed that of an ordinary tow rope. No disturbance of the water of the canal would be produced, except such as would be due to the progressive movement of the hull of the vessel. It would seem as though in this suggestion might be found a solution of the mechanical driving of canal-boats,—one that, from the points of view of simplicity, non-occupancy of the hull of the boat, and minimum disturbance of the water, would be nearly perfect.

The air-propeller works with an entire absence of vibration. It requires ten or twelve times the area of the corresponding water-screw. As the thrust is a perfectly quiet one, and, if due to the motion derived from a dynamo, would be free from the jarring inseparable from the motions of a heavy reciprocating engine, and as it is cushioned in all its motions by the high elasticity and mobility of the air, a very light frame would serve to carry the wheel. A thrust of 75 to 150 pounds would be all that the frame would be required to resist,—a thrust that would always be brought on it gradually, and would be gradually released. In steam canal-boats a very considerable portion of the hull is occupied by the engine, boilers, and coal-bunkers, while the constant eddies and currents produced by the propeller are destructive in their effect on the sides and bottom of the canal. This is all done away with in aerial propulsion. The establishment of a line of poles and wire would not represent the tithe of the cost of a fixed or travelling towing-cable.

INFLUENCE OF LIGHT ON MAGNETISM.—A preliminary notice of a very interesting experiment has been given by Mr. Shelford Bidwell. The investigation was undertaken to determine whether a piece of iron could be magnetized by allowing a ray of light to fall on it. Of course, if light is an electrical vibration, and if an effect was sought using an ordinary piece of iron, there would be no result, since the opposite vibrations would exactly neutralize each other's effects. But iron can be prepared so that it is more susceptible to a magnetic force acting in one direction than to one acting in the other. Ewing has shown, that, if a piece of iron which is being magnetized in what we call the positive direction has the magnetizing current reduced to zero at such a point in the operation that the current and the magnetization of the iron become zero at the same instant, then that piece of iron, although apparently in a neutral condition, is more susceptible to a negative than to a positive magnetizing force. So, if a piece of iron prepared in this way be submitted to the action of a ray of light, the positive and negative magnetizing forces produced, although equal, will not balance with one another, but the latter should produce an effect. On trying the experiment in this way, Mr. Bidwell ob-

tained a sudden throw of the magnetometer-needle, denoting the magnetization of the iron, followed by a slower motion due probably to the heating effect of the light. While Mr. Bidwell does not consider the results as altogether free from suspicion until all possible disturbing causes have been eliminated, yet, if further research confirms the results already arrived at, the experiment is most important. The last year has added many proofs of the fact that light is an electro-magnetic disturbance, but none are so conclusive as this would be.

THE PURIFICATION OF SEWAGE.—Last year we described the plan proposed by Mr. W. Webster for the purification of sewage by electrolytic methods. It has been since tried on a large scale, and with encouraging results. The process is very simple, and is described by the *London Electrician* as follows: "The color, density, and constitution of the London sewage varies from hour to hour in the most extraordinary manner; but the first sample to be dealt with was of a light-yellow color, looking something like weak tea with a little milk in it, but, so far as could be seen, it contained very little solid matter in mechanical suspension. This having been poured into a test-jar, a current was passed through it between a pair of iron electrodes, with about six volts electromotive force. An extremely rapid effect was produced. In less than two minutes the jar was seen to be filled with a flocculent precipitate, which was gradually carried upward by the bubbles of liberated hydrogen. After about three minutes, the electrodes were withdrawn, and the precipitate left to collect at the top. In actual practice, after the effluent has passed into the settling-tank, the precipitate, in the course of about two hours, loses the whole of the entangled hydrogen; it then sinks to the bottom of the tank. The sludge thus formed is similar to that produced by the chemical processes now in use, except that the electrical method possesses the obvious advantage that the total quantity of material has not been increased by the addition of chemicals." But, besides this precipitation, there is an action on the organic matters in solution which robs them of their unpleasant and harmful properties. In the larger experiments carried on at Crossness, two 20-horsepower engines are used, with an Edison-Hopkinson dynamo. Iron plates are placed in the shoot through which the sewage is discharged. In travelling along the shoot, every particle of the sewage comes in contact with the plates, and finally the whole is received into the settling-tanks. With 27 horse-power, it is possible to treat a million gallons of sewage in twenty-four hours. The consumption of iron in actual working is about two grains per gallon. Taking a town with a daily flow of ten million gallons of sewage a day, — corresponding to a population of about 300,000, — the consumption of iron should not exceed 304 tons per annum, and the steam-plant required would be about 250. This plant takes the place of the mixing-tanks, machinery, and chemicals employed in the chemical process for the purification of sewage; and, if such electrical plant is designed to meet the peculiar requirements of the district, it should cost less than any other method, besides precipitating and purifying in one operation.

SECONDARY BATTERIES. — We are informed that in the United States Circuit Court, April 9, Judge Coxe approved of the disclaimer filed by the Electrical Accumulator Company, and formulated the decree and injunction restraining the Julien Electric Company, their officers, agents, and workmen, from further manufacture, use, or sale of secondary batteries of the Faure type, in which the active material is applied to the support in the form of a *paint, paste, or cement*.

NOTES AND NEWS.

THE "Atlantic Pilot Chart for April" says of whirlwinds, water-spouts, and tornadoes, that these phenomena are of the same general character; and it has been found, that, whenever they occur, it is in connection with a general cyclonic storm of large area. The principles involved in their formation are almost identical with those that determine the formation of a tropical cyclone; that is, great contrasts of temperature and moisture between adjacent layers of air. In the United States and off our coasts they may therefore naturally be expected to occur to the

southward of a storm-centre, where cold, dry northerly winds blow over and mingle with warm moist air from the southward. That they may occur to the north of a storm-centre, however, under certain conditions, is indicated by a report from Second Officer Madge, of the British steamship "Lake Winnipeg," Capt. Murray. This vessel encountered a severe cyclonic storm Feb. 27, latitude 40° 50' north, longitude 56° 48' west; and at 2.30 P.M., when it was blowing a strong gale from the east, a whirlwind was observed moving due west. The barometer was low, and the warm, moist east wind was evidently underrunning a cold, dry current of air from the area of high barometer to the northward, where readings of 30.4 inches and upward are reported. It will thus be seen that local conditions of pressure, temperature, and moisture may cause exceptions to the general rule.

—The lectures to the summer class in botany, of the College of Pharmacy of the City of New York, by Professor Joseph Schrenk, commenced Wednesday, April 10, and will be continued every Wednesday until the end of June. By request of several members of former botany classes, Professor Schrenk will also give a course in practical microscopy.

—The Essex Institute of Salem, Mass., was organized March 1, 1848, under a charter granted by the Legislature in February of that year, having for its objects the collection and preservation of whatever relates to the geography, antiquities, and civil and ecclesiastical history of Essex County; the formation of a cabinet of natural productions in general, and more particularly those of the county; the promoting a taste for the cultivation of choice fruits and flowers; its three departments then being history, natural history, and horticulture. The scope of the institute has been from time to time enlarged, and there are now departments of history, science, literature, art, and horticulture. The library of the institute, which in 1848 numbered fifteen hundred volumes, now numbers fifty-one thousand volumes, and embraces all the departments of literature, but is mostly useful for reference. A reading-room is the latest addition to the library department, and this is well supplied with historical, scientific, and art periodicals, besides the usual magazine literature of the day. The museum of the institute now contains a large and valuable collection of antiquarian and historical relics, portraits, paintings, engravings, medals, coins, paper currency, manuscripts, etc., and is in process of systematic arrangement. The scientific collections, which before 1867 had grown to be so large and of such value that it was impossible for the institute at that time to bear the expense of properly caring for and exhibiting them, were, by agreement entered into between the institute and the trustees of the Peabody Academy of Science in May, 1867, deposited with the last-named institution, where, properly labelled, arranged, and preserved, they are made available to the public, and form an attractive feature of the academy's museum at East India Marine Hall. The publications of the institute regularly issued are the *Historical Collections*, which have now reached Vol. XXV.; *The Bulletin*, which has reached Vol. XXI., and contains records of the regular meetings and field-meetings of the institute, and special papers on scientific subjects; the *Annual Report*; besides occasional monographs, etc. The rooms of the institute contain portraits of the officers of the Essex Historical and Essex County Natural History Societies, the forerunners of the institute; old prints; silhouettes; a great number of interesting relics; historical portraits by Copley, Smibert, Trumbull, and others; antique furniture; local relics; and military costumes. A fire-proof room holds the large and invaluable collection of manuscripts. The meetings of the institute are held on the first and third Mondays of every month. During the winter months, papers are read; and field-meetings are held throughout the county every summer for scientific and historical investigation and discussion. Without considerable endowments in the past, the institute has been able to do for the civil history and archaeology of Essex County — and no other county in America offers a better field for such research — what has been so well done for the natural history of the county, a cherished object of the institute, by the well-equipped and earnest workers of the Peabody Academy of Science. With largely increased facilities and resources, which it owes to the general appreciation of its work, it is now ready to go forward, as

the means shall come to hand, to a still larger measure of usefulness and honorable effort.

— From his recent experiments on explosive mixtures of petroleum vapor and air, Col. Majendie concludes, says *Engineering*, that one volume of liquid benzine will render 16,000 volumes of air inflammable, and 5,000 volumes violently explosive. Though these results show that great care is necessary in storing benzines and crude petroleums, other of his experiments are more re-assuring, as he has found that neither a glowing coal, sparks from a flint or steel, or a flameless fusee, will ignite the most explosive mixture of petroleum vapor and air, actual contact with a flame or white-hot body being necessary.

— On Wednesday, March 6, according to *Engineering*, while a number of torpedo-boats belonging to the French Government were manœuvring off the coast at Toulon, one of them turned turtle, and three of her crew were drowned. The weather at the time of the accident was fair, with a north-east wind blowing, and a swell from the south-east. During the day every thing had gone perfectly successfully till at about 4.30 in the afternoon the boats proceeded to pass out of the Bay of St. Nazaire, between the Embezi Island and the Grand Rouveau, on their way back to Toulon. Three of the boats effected the passage in safety; but the third, No. 102, was, when partly through, struck by a heavy roller and completely capsized. Her commander saved himself by clinging to the rudder, and others of the crew also succeeded in escaping; but three of the engineers and mechanics, being in the engine-room or the stokehold, were unable to get out, and were drowned. The boat floated for forty-five minutes, and finally sank by the stern. The screw, it is stated, continued to revolve for some time after the boat had turned upside down. The No. 102 was a 53-ton boat, 114 feet 9 inches long, and belonged to a type which has been much criticised, and of which the French Government own or have ordered fifty-one specimens, most of which, it is said, have not yet been delivered, which is fortunate for the authorities. The officers of the navy have made many complaints as to the unseaworthiness of these boats. Although this has been the first one that has actually capsized, such a catastrophe has hitherto only been avoided by the exercise of the greatest care on the part of their crews.

— The Paris Exhibition authorities have not yet decided upon the plan to be adopted as to jury examinations of exhibits, or as to reports and awards; nor indeed is it by any means settled whether there will be any juries, reports, or awards at all. One thing, indeed, seems quite certain, — that there will be no distribution of medals, the utmost that would be done being the possible giving of diplomas of different shades of merit. Upon the whole, the chances appear in favor of a total abandonment of the jury and award system, and in its place the substitution of an official document given to every exhibitor, certifying his presence at the exhibition. The object of such a certificate does not appear very clear. So far as England is concerned, the editors of *Engineering* believe that the general feeling of exhibitors will be against the granting of awards; and this for several reasons. At Manchester and Glasgow, the abandonment of the system, which has been gradually falling into disrepute, was favorably received by the exhibitors, who are always — excepting, of course, the recipients of medals and diplomas — opposed to juries' reports, which they regard as more or less superficial and prejudiced. More especially will this objection hold good in Paris, where the very small proportion of British jurymen will render it almost impossible for English exhibitors to obtain a fair proportion of recognition in the general struggle of each country's representatives. But if the decision be taken, and we think it will be a wise decision, to follow the example that has been set in England, and abandon all attempts to pronounce on the respective merits of exhibitors, the present exhibition offers a splendid opportunity for a new departure in official recompense. The idea has been, we believe, submitted to M. Berger by a member of the British committee, and is receiving due attention. It is that awards, in the form of medals or diplomas, should be given to those men whose names are famous in industry and science, and whose works have been so distinguished that the fruits they have borne appear in all parts of the exhibition, though the distinguished

workers themselves take no part in it. The number is limited, and the list would not be difficult to prepare, for the names of such men are familiar to all the world. Pasteur, Chevreuil, Dumas, Gramme, Eiffel, De Lesseps, Bessemer, Wylde, Swan, Armstrong, Edison, Bell, Alvan Clarke, are conspicuous examples of those whose labors have advanced civilization in all its branches. So, too, those societies all over the world, whose mission it has been successfully to promote industry and science, could be appropriately recognized; for, without their help and co-operation in the general cause of advancement, the Paris Exhibition of 1889 would have fallen miserably short of its present measure of success.

— *Bradstreet's* states that a company has been formed under the laws of New York State to develop large deposits of ozokerite, a natural paraffine wax existing in the Wasatch Mountains of Utah Territory, about 113 miles east of Salt Lake City. These mines are said to contain the only deposits of this mineral known to exist, outside of Galicia, in Austria, whence the entire world's supply of this product has until recently been obtained. The Austrian mines are said to yield a product inferior in quality to that discovered in Utah. The uses of this mineral are constantly enlarging, and in this country alone the consumption amounts to 500 tons yearly. The chief uses of the mineral in its crude state are in the manufacture of waxed paper, in the lining of wooden vessels, in varnish and blacking manufacture, and in the insulating of electrical wires. The American product is said to differ from the Austrian article in that it does not need refining, but comes direct from the mine ready to be melted and applied, while the Austrian product must be refined in order to be applied to its numerous uses. When refined, this mineral is used in the adulteration of beeswax and as a substitute for that article in candle-making, the manufacture of matches and dolls, and in the making of heavy lubricants. In its natural state it is found in veins varying from ten to twelve inches thick, and varies in color from a light yellow to brown and black. Baryslaw, in Galicia, a town of 12,000 inhabitants, is dependent entirely upon the mining of this product for its existence. The price of refined ozokerite, commercially known as "ceresin," ranges from 20 cents per pound for chemically pure white, down to 6 cents per pound for crude black of a poor quality. The company proposes to mine 1,500 tons of the wax yearly, and pay 7 per cent on a capital stock of \$1,250,000. The first shipment from the American mines arrived in New York in January this year, and attracted considerable comment.

— In its forecast of the weather for April on the Atlantic, the United States Hydrographic Office states that westerly winds, of less force, however, than during March, will prevail over the transatlantic steamship routes east of the 60th meridian: west of that meridian, and along the Atlantic coast of the United States, the winds will be variable. Gales may be expected about once a week north of the 32d parallel. But few northers will be felt on the Gulf, and those that do occur will be of less duration than earlier in the season. Icebergs and field-ice may be encountered between 40° and 50° west, and as far south as 41° north; fields may also be met with inshore as far west as the 65th meridian. Considerable fog will be experienced off the Grand Banks and the coast of the United States as far south as Hatteras. The north-east trades, having reached their southernmost point during March, will this month begin to extend farther north.

— The alleged resistance offered by American grape-vines to the ravages of the phylloxera has recommended those vines to wine-growers of Europe, where the pest has made its presence felt. Much uncertainty has existed among the growers as to the particular variety best adapted to resisting the insect ravages, and some disagreement has also been noted between those who favored grafting American cuttings on French vines and those who proposed to replace the French by the American article entirely by planting the latter in the place of the former. Dr. Geza Von Horvath, of the Hungarian experimental station, who has been studying the subject for seven years past, has published in detail the results of his experiments, recently referred to in *Bradstreet's*. There is but one American variety, and that the *Vitis rotundifolia*, or Scuppernon, that will successfully resist any and all attempts of the pest upon its roots. Unfortunately the European growers

will not plant this grape, owing to its, to them, unpalatable taste, and also to the fact that European vines will not graft well with it. All other varieties of American vines are more or less liable to infection. Many varieties are said to be as vulnerable to the pest as any European vine. Many varieties depend on differing soils and other conditions to render them free of the infection. The Concord grape is classed as one that offers resistance to the pest only under exceptional circumstances. Other varieties which are more or less liable to infection are the York, Madeira, Herbemont, Jaquez, Cunningham, Clinton, Taylor, Elvira, and Othello. All American varieties not covered by the above names, it is said, either do not withstand the phylloxera at all, or have not yet been sufficiently tested as to their ability to do so.

— The French Government has appointed an international congress on the subject of mines and metallurgy, to be held in Paris on the 2d of September in this year, in connection with the exposition which is to take place there during the next summer. The congress has for its object to make known and discuss the most recent inventions and improvements in mining and metallurgy, and will have brought before it a considerable number of memoirs which have been prepared by engineers specially detailed for the purpose. These reports will be printed and distributed in advance to persons who wish to become members of the congress, and will form the basis of the discussion; but other subjects may be introduced or other questions presented by the members, with the approbation of the officers in charge. The congress will consist of members and honorary members, the honorary members being appointed by the French Government, and the members becoming so upon the payment of twenty francs. Letters and communications from this country relating to the subject of mines and metallurgy may be addressed to Mr. Castel, inspector-general of mines, and president of the organizing commission, 144 Boulevard Raspail, Paris. The committee appointed by the French Government consists of, president, Mr. Castel (inspector-general of mines, president of the Society of Mineral Industry); vice-presidents, Mr. Brüll (past-president of the Society of Civil Engineers in Paris), Mr. Haton de la Goupilliere (member of the institute, inspector-general of mines, director of the School of Mines of Paris), Mr. Jordan (professor of metallurgy at the Central School, past-president of the Society of Civil Engineers of Paris), and Mr. Rémaury (civil engineer of mines); secretaries, Mr. Dujardin-Beaumez (secretary of the central committee of coal-mines), Mr. Gautier (civil engineer of mines), Mr. E. Gruner (civil engineer of mines), and Mr. Lodin (engineer of mines, professor of metallurgy at the School of Mines in Paris).

— It is said that John G. Borden of New York, who spends his winters in Florida, has offered a prize of \$1,000 to the Florida city which shall, on July 1, 1889, present the most cleanly appearance.

— Mr. Whitman Cross presents, in an article in the *American Journal of Science* for April, an account of a newly recognized tertiary formation, which, while of very limited geographical extent, yet possesses characteristics of importance in several directions. The points of interest brought out may be grouped as follows: 1. The formation in question occupies a portion of the area about the city of Denver, Col., hitherto assigned to the Laramie cretaceous; 2. The conglomerates and sandstones of the formation are chiefly made up of materials derived from a great variety of andesitic lavas, of whose outpouring and destruction alike there is no other record now known; 3. The celebrated fossil-plant beds of Table Mountain, at Golden, belong to the Denver formation, hence the taxonomic value which has been given to this rich flora must be considered subject to revision; 4. The vertebrate remains are of individual importance, and also present some very remarkable associations, which are apparently in direct conflict with all past observations.

— An electrical and industrial exhibition is to be held in Birmingham, England, during the months of August, September, and October. A very large amount of support has been promised for it, and there is every prospect that it will prove a success. The electrical department will be divided into three sections: the first including all kinds of machinery and apparatus for electric light-

ing; the second relating to complete displays of electric lighting on various systems; and the third comprising telegraphs, telephones, phonographs, electric bells and clocks, electric welding and smelting, electrotyping, telpelherage, and miscellaneous apparatus. The industrial section will consist largely of Birmingham manufactures and manufacturing processes, although it will include many other subjects. The former will be specially interesting. The small trades of Birmingham form a *terra incognita* to the engineer, and an immense amount of ingenuity is exercised in producing the numberless small articles which are turned out from the capital of the Midlands.

— A "graphic" exhibition is to be held at Stuttgart next June, in celebration of the King's Jubilee. This exhibition is limited to firms or institutions of Wurtemberg. It will comprise the following sections: 1. All branches of the publishing business, such as books, musical works, and periodicals, as well as other auxiliary arts and processes, viz., engraving, lithography, chromolithography, xylography, zincography, photography, etc.; 2. Collections of kindred articles belonging to, or represented by, subjects of Wurtemberg; 3. Bookbinders' work, book tools and stamps; 4. Paper, and wares manufactured from the same; 5. Mechanical processes in operation, especially in the form of type-founding and accelerated printing-presses; 6. An historical display of ancient specimens of the graphic arts, as also of ancient Wurtemberg, artistic journals, illustrations, bindings, calligraphy, etc. The Royal Library at Stuttgart, which possesses one of the richest collections of Bibles, will alone provide a choice display of manuscript and printed books.

— Dr. J. H. Kidder of the Smithsonian Institution died April 8, at his residence in Washington, from an attack of pneumonia. Dr. Kidder served as a surgeon in the navy until he resigned, about twelve years ago. Since that time he has been connected with the scientific branch of the government service. Under Professor Baird, he was connected with the Fish Commission, and latterly he was director of the International Exchange, in the Smithsonian Institution. He leaves a wife, daughter of ex-Postmaster-General Maynard of Tennessee, and three children.

— At a meeting of the American Academy of Arts and Sciences, April 10, in Boston, the Rumford medals were presented to Professor Albert A. Michelson.

— The Société Botanique de France has decided to take advantage of the universal exposition to invite botanists who may be in Paris to a congress during the last half of the month of August, 1889. Those who take part in the congress can present papers on botanical subjects, pure or applied, with which they may be especially familiar. The society also intends to take advantage of the presence in Paris of a large number of prominent scientific men to bring forward for discussion a number of leading botanical questions. Among these will be the preparation of a botanical map similar to the geological maps prepared under the auspices of the Geological Congress and the aid which anatomy can furnish in classification.

— The unsightly efflorescence on walls, due to what is termed "saltpetring," and noticed generally in dry weather, is due, according to *Building News*, to several causes. Perhaps the only satisfactory explanation is that the newly built brick wall is exposed to dampness, or dampness in co-operation with something in the bricks themselves. It is stated that bricks made from clay containing iron pyrites are subject to this efflorescence; that the sulphur from the fuel converts the lime or magnesia into sulphates; and that whenever the bricks dry the sulphates evaporate, leaving behind the crystalline appearance or efflorescence. The evil is therefore due to the chemical action that takes place between the sulphur in the fuel and the magnesia in the clay. The mischievous part of the efflorescence is that it destroys the pointing, and injures the work generally. Remedies are few. The chief object is to stop up the pores with some solution of fatty matter, quicklime, and cement powder; but the main thing is to avoid the particular clay and coal fires employed to make and burn the bricks, and to mix the mortar with animal fat.

SCIENCE:

A WEEKLY NEWSPAPER OF ALL THE ARTS AND SCIENCES.

PUBLISHED BY

N. D. C. HODGES,

47 LAFAYETTE PLACE, NEW YORK.

SUBSCRIPTIONS.—United States and Canada.....\$3.50 a year.
Great Britain and Europe..... 4.50 a year.

Science Club-rates for the United States and Canada (in one remittance):

1	subscription	1 year.....	\$ 3.50
2	"	1 year.....	6.00
3	"	1 year.....	8.00
4	"	1 year.....	10.00

Communications will be welcomed from any quarter. Rejected manuscripts will be returned to the authors only when the requisite amount of postage accompanies the manuscript. Whatever is intended for insertion must be authenticated by the name and address of the writer; not necessarily for publication, but as a guaranty of good faith. We do not hold ourselves responsible for any view or opinions expressed in the communications of our correspondents.

VOL. XIII. NEW YORK, APRIL 12, 1889. No. 323.

CONTENTS:

MICHEL EUGENE CHEVREUL.....	271	The Purification of Sewage.....	279	
THE SMITH ELECTRIC CONDUIT SYSTEM.....	272	Secondary Batteries.....	279	
SNOW-BROOM FOR USE ON ELECTRIC RAILWAYS.....	273	NOTES AND NEWS.....	279	
THE EXTENSION OF THE METRIC SYSTEM.....	273	EDITORIAL.....	282	
EXCAVATIONS FACILITATED BY FREEZING.....	274	The News from Stanley.....		
THE LIGNITE INDUSTRY IN GERMANY.....	274	STANLEY'S LETTER.....	282	
THE CHINCH-BUG IN ILLINOIS.....	275	CALIFORNIA WINES.....	284	
THE WAGNER REGULATOR.....	275	BOOK-REVIEWS.....		
HEALTH MATTERS.....		Chambers's Encyclopædia.....	285	
The Hughes Crematory.....	277	Harper's Readers.....	285	
The Morphine Habit.....	277	Longmans' New Atlas.....	285	
Schoolroom Space.....	277	AMONG THE PUBLISHERS.....	286	
Sulphur Fumigation.....	277	LETTERS TO THE EDITOR.....		
Dried Potato.....	277	The Robinson Anemometer.....		
Spontaneous Combustion.....	277	C. F. Marvin.....	289	
The Suppression of Small-Pox.....	278	The Metric System and Professional Teaching.....	289	
ELECTRICAL NEWS.....		W. H. Seaman.....	289	
Canal-Boat Propulsion.....	278	Platinum in British Columbia.....		
Influence of Light on Magnetism.....	278	George M. Dawson.....	290	
		The Age of the Denver Formation.....		
		E. D. Cope.....	290	
		Platinum in Place.....	W. G. Brown.....	290

THE NEWS of Stanley's journey from Yambuya to Mvutan Nzige confirms the view formerly expressed, that his object of relieving Emin Pacha has failed. From his report we learn that Emin, rather, had to relieve him, and, by furnishing men, has enabled him to return to the Kongo. The results of Stanley's wonderful journey will undoubtedly be of the greatest importance to science, as they will clear up the geographical relations between the Kongo basin and the lakes of the upper Nile. Regarding the appearance of this region, Stanley says: "We were one hundred and sixty days in the forest, — one continuous, unbroken, compact forest. The grass-land was traversed by us in eight days. The limits of the forest along the edge of the grass-land are well marked. We saw it extending north-easterly, with its curves, bays, and capes, just like a seashore. South-westerly it preserved the same character. North and south the forest area extends from Nyangwe to the southern borders of Mombuttu. East and west it embraces all the country from the Kongo, at the mouth of the Aruvimi, to about east longitude 29°. How far west beyond the Kongo the forest reaches, I do not know. The superficial extent of the tract described totally covered by forest is 246,000 square miles. North of the Kongo, between Upoto and the Aruvimi, the forest embraces another 20,000 square miles. Between Yambuya and Mvutan Nzige we came across five distinct languages. The land slopes gently from the crest of the plateau above the Mvutan down to the Kongo River, from an altitude of 5,500 feet to 1,400 feet above

the sea. North and south of our track through the grass-land the fall of the land was much broken by groups of cones or isolated mountain ridges. To the north we saw no land higher than about 6,000 feet above the sea; but bearing 215° magnetic, at a distance of 50 miles from our camp on the Mvutan, we saw a towering mountain, its summit covered with snow, probably 17,000 or 18,000 feet above the sea. It is called Ruevenzori, and will prove a rival to Kilma Njaro. I am not sure that it may not prove to be the Gordon Bennett Mountain in Gamberagara, but there are two reasons for doubting it if be the same: first, it is a little too far west for the position of the latter, as given by me in 1876; second, we saw no snow on the Gordon Bennett. I have met only three natives who have seen the lake toward the south. They agree that it is large, but not so large as the Albert Nyanza." We give the substance of Stanley's experiences at another place.

As usual, this news was immediately followed by another despatch, purporting to give further details of more recent adventures of the explorers; but, coming as it does from Brussels, it merits more serious attention than the Zanibar news of Reuter's bureau. The telegram is dated Brussels, April 7, and says, "Advices received here from Stanley Falls state that Arabs who have arrived there report that Henry M. Stanley and Emin Pacha were heard from in February. They were then marching toward Zanzibar, with several thousand men, women, and children. They also had six thousand tusks of ivory. The Arabs who brought the news arrived at Stanley Falls in February. They claimed to have seen Stanley several months before that time." It may be that the steamer which carried this news to Leopoldville brought down Stanley's letter, which, as will be remembered, was detained for some reason or other at Stanley Falls when the first news of Stanley's return was sent to Europe. One interesting fact is learned from Stanley's report. It is the recent advance made by the Arab slave-dealers in the country north of Stanley Falls. It appears that since their first advent on the Kongo they have rapidly encroached upon the territory of the northern tributaries of the Kongo; and it also appears that at no very distant day the invaders who started from Dar For, and those who extended their raids from Zanzibar, will meet in the Welle region. In the face of these facts, the endeavors of the European nations to suppress that insignificant part of the slave-trade reaching the coast appear altogether hopeless, unless they succeed in cutting off the supply of fire-arms from the slave-dealers, thus destroying one of the principal causes of their superiority over the aborigines.

STANLEY'S LETTER.

STANLEY'S letter, although containing no more recent information than the telegram sent a few months ago, describes graphically the enormous difficulties encountered by the intrepid explorer; and his description is the more impressive on account of its briefness and of the simplicity with which the most exciting events are set forth. The expedition, which consisted of 389 officers and men, started from the camp of Yambuya, on the Aruvimi, on June 28, 1887. The very first day the natives attempted to prevent the progress of the expedition, but were unable to put any serious obstacles in its way. For seven days the expedition marched inland in an easterly direction, through a densely populated district. Evidently Stanley kept on the southern side of the river. His letter says that this course took him out of his proper direction, which tends to confirm the report that the Aruvimi runs more southerly than indicated in most maps. He again reached the river on July 5. From this date until Oct. 18 he followed the left bank of the Aruvimi. After seventeen days of continuous marching, the expedition halted for one day's rest. Aug. 1 the first death occurred, the cause being dysentery. So far, for thirty-four days, the course had been singularly successful.

Assuming that he made good progress, his first day's journey having been twelve miles, he would have been approximately north-east of Stanley Falls. Here his difficulties began. The party

now entered a wild country, in their nine-days' march through which their sufferings multiplied, and several deaths occurred. Aug. 13, on arriving at Airsibba, the natives presented a bold front, and the party lost five men from poisoned arrows. Lieut. Stairs was wounded below the heart, and suffered greatly, but he recovered. Aug. 31 the expedition met a party of Manyema, and their misfortunes began on this date. Stanley writes that he had taken the Kongo route to avoid Arabs who would tempt his men. Within three days of this unfortunate meeting, twenty-six men deserted. This must have happened not very far distant from the most southern region visited by Junker.

While crossing the region raided by Arab slave-traders, who, with their Manyema men, came from Stanley Falls, the progress of the caravan was an uninterrupted series of misfortunes. On Sept. 18 he left the station of the Arab chief Ugarrava, the expedition numbering 263 men, 66 having been lost by desertion and death, and 56 being left sick with Ugarrava. The march led to the Arab settlement, Kalinga Longa. The men lived on wild fruits, fungi, and nuts. Before reaching Kalinga Longa, Stanley lost 55 men through starvation and desertion. A slave-owner at Kalinga Longa named Ab ed Salim did his utmost to ruin the expedition short of open hostilities. He insisted upon purchasing rifles, ammunition, and clothing, so that the expedition left the station beggared. The men were absolutely naked, and were so weak that they were unable to carry the boat. Stanley was therefore obliged to leave the boat, together with 70 loads of goods, at Kalinga Longa, under the care of Surgeon Parke and Capt. Nelson, the latter of whom was unable to march. After a twelve-days' journey, the party, Nov. 12, reached Ibwiri. The Arab devastation, which had reached within a few miles of Ibwiri, was so thorough that not a native hut was left standing between Ugarrava and Ibwiri. What the Arabs did not destroy, the elephants destroyed, turning the whole region into a horrible wilderness.

It appears that Ibwiri is situated in about 29° east longitude, 126 miles distant from Lake Mwtan Nzige. In a later passage of his letter, Stanley gives the distance of Kalinga Longa from the lake as 190 miles, which leaves a distance of 64 miles for the line from Kalinga Longa to Ibwiri. The former place may therefore be situated near the sources of the Nepoko. It does not appear clearly where Stanley left the Aruvimi, but it would seem that this happened at Kalinga Longa or near it. This seems the more probable, as he left his boat there. Stanley continues:—

"Our sufferings terminated at Ibwiri. We were beyond the reach of destroyers. We were on virgin soil in a populous region abounding with food. We ourselves were mere skeletons. From 289 persons, we now numbered 174. Several of the party seeming to have no hope of life left, a halt was therefore ordered for the purpose of recuperating. Hitherto our people were sceptical of what we told them. The suffering had been so awful, the calamities so numerous, and the forests so endless, that they refused to believe that by and by we would see plains and cattle, the Nyanza, and Emin Pacha. They had turned a deaf ear to our prayers and entreaties; for, driven by hunger and suffering, they sold their rifles and equipments for a few ears of Indian-corn, deserted with the ammunition, and became altogether demoralized. Perceiving that mild punishment would be of no avail, I resorted to the death-penalty, and two of the worst cases were hanged in the presence of all. We halted for thirteen days at Ibwiri, reveling on fowls, goats, bananas, corn, yams, etc. The supplies were inexhaustible, and our people glutted themselves with such effect that we had 173 sleek and robust men. One had been killed with an arrow.

"When we started for Albert Nyanza, Nov. 24, we were still 126 miles from the lake. Given food, the distance seemed nothing. Dec. 1 we sighted an open country from the top of a ridge connected with Mount Pigsaw, which was so named from our first view of the land of promise and plenty. Dec. 5 we emerged on the plains, leaving the deadly and gloomy forest behind us. After one hundred and sixty days of continuous gloom we saw the light of broad day shining all around, making all things beautiful. We thought we had never seen grass so green, or a country so lovely. The men literally leaped and yelled with joy, and raced over the ground with their burdens. Ah! this was the old spirit of former

expeditions successfully completed, and all suddenly revived. Woe betide the native aggressor whom we may meet! However powerful, with such a spirit the men will fling themselves upon him like wolves on sheep. Numbers will not be considered. It was the eternal forest that had made them the abject, slavish creatures so brutally plundered by Arab slaves at Kalinga Longa.

"At Kilonga Wonga, on the 9th, we entered the country of the powerful chief, Mazamboni. The villages were scattered so thickly that no road except through them could be found. The natives sighted us, but we were prepared. We seized a hill as soon as we arrived in the centre of a mass of villages, and built a seriba as fast as bill-hooks could cut the brushwood. The war cries were terrible, from hill to hill, pealing across the intervening valleys. The people gathered in hundreds at every point, war-horns and drums announcing the struggle. After a slight skirmish, ending in our capturing a cow, the first beef we had tasted since we left the ocean, the night passed peacefully, both sides preparing for the morrow."

Here Stanley narrates how negotiations with the natives failed, Mazamboni declining a peace offering, and how a detachment of forty persons led by Lieut. Stairs, and another of thirty under command of Mr. Jephson, with sharpshooters, left the zereba, and assaulted and carried the villages, driving the natives into a general rout. The march was resumed on the 12th. There were constant little fights all along the route. The afternoon of the 13th the caravan sighted the Nyanza. The descent from the plateau, which Stanley describes as 5,200 feet above the sea, to the lake, which is 2,300 feet high, seems to have been very difficult. Besides this, the caravan had to suffer from attacks of the natives. The natives of the lake did not receive Stanley kindly, but, for lack of a boat, he was unable to proceed. There were no trees of a size sufficient to make canoes. Here the significant passage occurs, "We had used five cases of cartridges in five days' fighting on the plain; a month of such fighting must exhaust our stock;" which shows that Stanley's caravan could not be of any assistance to Emin.

His disappointment must have been great, when, after finally reaching the lake, after having overcome the greatest difficulties, he was compelled to retrace his steps in order to bring his boat, which had been left in Kalinga Longa. He continues: "On Jan. 7 we were in Ibwiri once again. After a few days' rest, Lieut. Stairs, with 100 men, was sent to Kalinga Longa to bring the boat and goods. I also sent Surgeon Parke and Capt. Nelson. Out of the 38 sick men in their charge, only 11 men were brought to the fort. The rest had died or deserted.

"On the return of Stairs with the boat and goods, he was sent to Ugarrava. He was to bring up the convalescent. Soon after his departure, I was attacked by gastritis and an abscess on the arm. After a month's careful nursing by Parke, I recovered, and set out again for the Albert Nyanza on April 2, accompanied by Jephson and Parke. Nelson was appointed commandant of Fort Bodo in our absence, with a garrison of 43 men and boys. On April 26 we arrived in Mazamboni's country again. This time, after solicitation, Mazamboni decided to make blood brotherhood with me. His example was followed by all the other chiefs as far as the Nyanza. Every difficulty seemed now to be removed. Food was supplied gratis. Cattle, goats, sheep, and fowls were also given in abundance, so that our people lived royally.

"When one day's march from the Nyanza, natives came from Kavali and said that a white man named Malejja had given their chief a black packet to give me, his son. Would I follow them, they asked. 'Yes, to-morrow,' I answered. 'And if your words are true, I will make you rich.' They remained with us that night, telling us wonderful stories about big ships as large as islands, filled with men, etc., which left no doubt in our mind that the white man was Emin Pacha. The next day's march brought us to Chief Kavali. After a while he handed me a note from Emin Pacha, covered with a strip of black American oilcloth. The note was to the effect, that, as there had been a native rumor that a white man had been seen at the south end of the lake, he had gone in a steamer to make inquiries, but had been unable to obtain reliable information. He begged me to remain where I was until he could communicate with me.

"The next day, April 23, Mr. Jephson was despatched with a strong force to take the boat to the Nyanza. On the 26th the boat's crew sighted Mawa Station, the southernmost belonging to Emin Pacha. Mr. Jephson was there hospitably received by the Egyptian garrison. The boat's crew said that they were embraced one by one, and that they never had such attention shown to them as by these men, who hailed them as brothers. On April 29 we once again reached the bivouac ground occupied by us on Dec. 16, and at 5 P.M. of that day I saw the Khédive steamer about seven miles away steaming up toward us. Soon after 7 P.M., Emin Pacha, Signor Casati, and Mr. Jephson arrived at our camp, where they were heartily welcomed by all of us. Next day we moved to a better camping-place, about three miles above Nyamsassie, and at this spot Emin Pacha also made his camp.

"We were together until May 25, when I left him, leaving Jephson, three Sudanese, and two Zanzibaris in his care. In return he caused to accompany me three of his irregulars and 102 Madi natives as porters. Fourteen days later I was at Fort Bodo. At the fort were Capt. Nelson and Lieut. Stairs. The latter had returned from Ugarrava twenty-two days after I had set out for the lake, bringing with him, alas! only 16 men out of 56. All the rest were dead. My 20 couriers whom I had sent with letters to Major Barttelot had safely left Ugarrava for Yambuya on March 16. Fort Bodo was in a flourishing state. Nearly ten acres were under cultivation. One crop of Indian-corn had been harvested, and was in the granaries. On June 16 I left Fort Bodo with 111 Zanzibaris and 101 of Emin's people. Lieut. Stairs was appointed commandant of the fort, Capt. Nelson was second in command, and Surgeon Parke was medical officer. The garrison consisted of 59 rifles. I thus deprived myself of all my officers in order not to be encumbered with baggage, provisions, and medicines, which would have to be taken if accompanied by Europeans.

"On June 24 we reached Kilonga, and on July 19 Ugarrava. The latter station was deserted. Ugarrava, having gathered as much ivory as he could obtain from the district, had proceeded down the river about three months before. On leaving Fort Bodo, I had loaded every carrier with 60 pounds of corn, so that we were able to pass through the wilderness unscathed. Passing on down the river as fast as we could go, daily expecting to meet the couriers, who had been stimulated to exert themselves for a reward of £10 per head, or the major himself, leading an army of carriers, we indulged ourselves in pleasing anticipation as we neared the goal. On Aug. 10 we overtook Ugarrava with an immense flotilla of 57 canoes, and, to our wonder, our couriers, now reduced to 17, who related an awful story of hairbreadth escapes and tragic scenes. Three had been slain, two were still feeble from wounds, and all except five bore on their bodies the scars of arrow-wounds. A week later, Aug. 17, we met the rear column of the expedition at Bunalya."

Then Stanley goes on to describe his disappointment at hearing of the disaster that had befallen his rear guard, and says that he intended to go back to the Albert Nyanza to unite with Emin.

CALIFORNIA WINES.

A REPORT by Major B. C. Truman, and published by the Los Angeles Board of Trade, expresses some optimistic views of the future of California wines, which seem likely to be realized.

No one acquainted with the varied soil and diversified climate of California can doubt that it is to that State that the American people are to look for the wines which will in time take the place of the vintages of Bordeaux, Rheims, Epernay, Oporto, Madeira, and Tokay. California may not probably produce a Chateau Lafitte, a White Hermitage, or a Chablis, for some time to come; she may never perhaps be able to produce similar wines; but, even if she succeeds in perfecting processes of wine-making, and producing brands that are rich in bouquet and aroma, they may never, in the estimation of some, reach the perfection of those just named, and otherwise not be like them. No two wine-producing countries are precisely alike, although there may be similarity of climate, soil, cultivation, and manipulation. In California, grapes are grown in all kinds of soil, altitudes, and under very dissimilar atmospheric conditions; some of these conditions of climate, soil, and altitude

resembling France and Italy, others Germany and Greece, others Spain and Portugal, while not a few of the Californian conditions are totally different from those of the European wine districts. Thus, to a great extent, the result will be the production of a new type; and our vintages, with their pretty names, may sound as sweetly in the ear of the connoisseur of the next generation as do Rousillon or Amontillado in our own.

During the last thirty years improvements have been made, and are still being made, in the cultivation of the vine, and the processes of wine-making in California. Commissioners and experts have visited foreign countries, and skilled workmen from leading European vineyards and wine-houses have been brought over here at great cost. Cuttings from all the rare vines of Europe have been imported, and all possible information respecting the cultivation of the vine, and the processes of wine-making, have been collected from every available source. Some species do not take kindly to this new climate and soil, while others appear to have gained new virtues; and although we cannot always expect that the identical flavor of the wine from the imported vine will be repeated in their new home, still many show a decided improvement. There are Rieslings in the market now, and some rare old white wines without a name in many a cellar, which, had their bottles been decked with the picture of some ruined old castle, might pass for a real Teutonic article from the banks of the Rhine. Other wines, like the Cucamonga of San Bernardino and the Angelica of Los Angeles, are noted for their luscious sweetness. Other blendings, like Kohler's or Baldwin's Bonanzas, have a quaint and fascinating flavor, while there are ports enough like their namesakes to defy comparison, and some sherries and muscatels which at no distant date will substantially supplant that class of imported wines in the United States.

As an illustration of the growing popularity of Californian wines at home, it is not too much to say that twenty years ago not ten gentlemen in the State ever placed either native wines or brandy on their table. Gradually, however, the white and red acid wines of Los Angeles and other counties improved, and were trusted; and now no Californian is ashamed of entertaining his guest with either the Sauterne, Hock, Muscatel, Zinfandel (claret), Riesling, or Burgundy of his native land. These wines are becoming favorites in the Eastern States, and even in England, and particularly among connoisseurs who know pure wines from adulterated ones. It also may not be generally known that certain French firms even export to their American customers red wines which were originally made in California, and shipped to France for the purpose of adulteration, or, at least, deception. The port wine from Los Angeles County is undoubtedly the best, purest, and truest port used in the country. It is palatable, medicinal in its effects, and purer than any port that comes from foreign countries, or that is manufactured in the cellars of importing-houses of New York and other Eastern cities. The Californian sherry is also gaining in favor, and its sale is daily increasing in the East; and what has just been said of the Californian port and the foreign article holds good for the sherry of California and its rival from abroad.

The excellence of the Californian vintages lies in their absolute purity, but they lack age and that exquisite manipulation which imparts to imported concoctions a mellow taste and an acceptable aroma. There is a nutty flavor to the so-called cheap sherry from abroad, that often pleases the senses more than that of the unadulterated sherry from California; and, while the former is actually guilty of deleterious effects, the latter is only deemed deficient in high-bred quality, which may be traced to its newness, and nothing else. Angelica wine from Los Angeles County has always been a favorite in the East, and is the wine that attracted the admiration of the jurors of the Paris Exhibition in 1867.

There is no other vegetable growth in California which finds so generally a congenial place as the grape. It is a good bearer, and never fails if properly attended to. It never greatly suffers from cold or heat, or other elemental disturbance, and does not average one pound of decayed or indifferent berries in a thousand in the pickings. The vine suffers nothing from the elements, as a general rule; although whole vineyards in the lowlands, which have been primed too early, have been injured by frost, and so rendered non-producing for one season. The phylloxera has as yet occasioned

no alarm in southern California, and has never been known to have injured what is called the natural Californica, Arizona, or Missouri vine or stock. No fertilizer is used by the viticulturists, as the soil is too strong, if any thing, to produce a grape which shall make a table wine with as little alcoholic percentage as possible.

Los Angeles County, while it has achieved much success during the past fifteen years in its production of hock, burgundy, and claret, excels more particularly in its port, sherry, madeira, angelica, and other sweet and heavy wines. The acreage of vineyards in southern California is always increasing.

Year.	Acreage.	Number of Vines.
1856.....	1,300	1,500,000
1879.....	56,000	45,000,000
1880.....	68,000	55,000,000
1881.....	80,000	64,000,000
1888.....	150,000	120,000,000

The wine product of these vineyards for the past eleven years was as follows:—

Year.	Gallons.
1877.....	4,000,000
1878.....	5,000,000
1879.....	7,000,000
1880.....	10,000,000
1881.....	8,000,000
1882.....	9,000,000
1883.....	8,500,000
1884.....	10,000,000
1885.....	11,000,000
1886.....	18,000,000
1887.....	25,000,000
1888 (estimated).....	17,000,000

In addition to the large quantity of wine and brandy manufactured, 85,000 boxes of raisins were exported from Los Angeles County alone, while the entire raisin pack for southern California amounted for the same period to 1,250,000 boxes, as compared with only 11,000 boxes in 1875.

BOOK-REVIEWS.

Chambers's Encyclopædia. New ed. Vol. III. Catarrh to Dion. Philadelphia, Lippincott. 8°. \$3.

THIS volume, it is perhaps needless to say, maintains the same excellence shown in the two already reviewed in these columns. The number of illustrations is noticeable, as is also that of the maps, five of which are given. These maps, of China, Colorado, Connecticut, Delaware, and Denmark, show exactly what is wanted by the general user of maps,—the location of the chief political divisions and the towns,—very little or no attention being paid to the physical features. This is noteworthy in view of the tendency, on the part of some modern geographers, to lay special stress on the physical features, at least in school-geographies and in some atlases, but probably without due appreciation of the demand of the public at large that a map shall be a convenient diagram of the location of towns, counties, and states. It is doubtful whether it is often important to a person using an atlas whether even the rivers are carefully given. Rivers have ceased to have their former value as avenues of communication, having been superseded by railroads. It is likely, therefore, that a map showing the railways more clearly than the rivers would more nearly serve the purposes of ordinary every-day reference. We certainly indorse the maps as given in this volume.

A number of articles on American topics are specially copyrighted in the United States; and among these it is worthy of note that an addendum is made to the article on "Cheese," to cover American cheese, which is now so largely exported to England. "Dairy Factories" is another of these American articles, this being one more evidence of the development of entirely novel methods in this country for providing cheese and butter.

Grover Cleveland receives notice from an American pen; but it is a surprise to find so early an immigrant as Christopher Columbus treated of by one of our countrymen.

To indicate the character of the articles, we may mention that most of the geological ones are contributed by Professor James Geikie; the botanical ones, by Professor Patrick Geddes; the philosophical ones, by Professor Seth; and the legal ones, by Mr. Thomas Raleigh. Professor Rhys has written on the "Celts;" the Duke of Argyll, on "Clans;" Professor Legge, on "China;" Sir Edward Watkin, on the "Channel Tunnel;" Lord Brassey, on "Coaling Stations;" Lord Napier and Ettrick, on "Crofters;" Mr. Goldwin Smith, on "Cromwell;" Professor Nicholson, on "Currency;" Mr. E. W. Streeter, on "Diamonds;" Mr. A. J. Ellis, on "Dialect." The writers of literary biographies include the names of Walter Besant, A. H. Bullen, Professor J. W. Hales, George Saintsbury, and Theodore Watts.

Those who wish at hand a convenient reference-book, arranged by topics, and not made up of the elaborate treatises of some of the larger encyclopædias, should keep Chambers in mind.

Harper's First, Second, Third, and Fourth Readers. 4 vols. New York, Harper. 12°.

IF the rising generation is not properly educated, it will not be due to a lack of books. Publishers vie with each other in bringing out new school-books with all the improvements, both literary and mechanical, that experience and ingenuity can suggest. Under these circumstances, it is impossible that any one series of text-books should possess very decided superiority over others of the same class; and this is particularly the case with reading-books, on which so much labor has been expended. Nevertheless new readers will from time to time be needed, and the Messrs. Harper have sent us a series of them which they claim are superior in some respects to any hitherto prepared. The first of the series, which is intended for very young pupils, has been edited by Professor O. T. Bright; the editor of the others being Mr. James Baldwin. The volumes of the series are carefully graded, and the new words introduced in each lesson are given in a table at the end of the lesson, while a pronouncing and defining vocabulary of all the new words in the volume is placed at the end of the book. All the volumes are, of course, illustrated: and every means has been used to make them attractive to young persons, both in appearance and in their literary contents. The third and fourth numbers of the series contain many articles on history, the habits of animals, and other topics of importance; and in all the books moral lessons are inculcated as opportunity is presented. Throughout the series the attempt has been made to give the young reader really good literature, and the attempt has been attended with a good deal of success. Whatever may be the relative merit of these readers as compared with others, their positive merit seems to us of a high order.

Longmans' New Atlas. Ed. by GEORGE G. CHISHOLM. London and New York, Longmans, Green, & Co. 8°. \$4.

THREE years ago we had occasion to remark favorably upon "Longmans' School Geography," by George Chisholm. The same author supplements his previous work most fortunately by the present atlas. Acting upon the advice of the Royal Geographical Society's committee, he has followed, as far as circumstances permit, German educationists; and the endeavor to make the best use of German works on school geography has led to excellent results in the present atlas. The author has evidently been guided to a great extent by "Sydow-Wagner's Atlas." The atlas is primarily designed for use in schools. With this view, three things have been aimed at as of chief importance,—first, the adequate representation of the physical features; second, the careful and somewhat exclusive selection of names; third, the facilitation of comparison as to size between the countries and regions included in the different maps. Physical features and political outlines are represented on the same maps.

In the selection of names the chief aim has been to insert no more than are necessary, and this aim has been kept in view not merely with the intention of rendering it possible to engrave all the names clearly in fairly large letters. The maps have in many cases been left comparatively bare in this regard, because every superfluous name tends to reduce the utility of a map for educational purposes. In school-maps it ought to be regarded as one of the first essentials that the names should be few. But the atlas

may also be used as a work of reference. For this purpose a great many more names have been included in the index than are named on the maps, their position being given by latitude and longitude.

The atlas is certainly of great value, and marks a new departure in the teaching of geography in higher schools. While we acknowledge the full importance of the work as a whole, we have to remark on a few minor points. The first of these is the lack of uniformity in the use of colors. Thus the author designates depressions by approximately the same color which is used for land between 500 and 1,000 feet on other maps. Furthermore, we miss throughout a uniformity of treatment of the depths of sea. In the contour-line maps of England, Ireland, and Scotland, the hundred-fathom line only is indicated, no additional details being given to the map of western Europe. It is the object of lines of equal depth to continue the representation of the earth's surface under the level of the water: therefore lines of height and of depth must be given in equal detail. The same applies to the other maps of the atlas. Map 3, illustrating methods of hill-drawing, is evidently an imitation of the corresponding map of "Sydow-Wagner's Atlas;" but it compares very unfavorably with it, the hachures in the various engravings of the same region not representing the same slopes and even configuration. An appendix contains a great number of typical views of landscapes, towns, products, and human races.

AMONG THE PUBLISHERS.

A DESPATCH from the City of Mexico reports that Adolph Sutor, of Comstock Mine and Sutor Tunnel fame, who is travelling in South America, bought in an old bookstall in that city what is claimed to be a genuine copy of the first folio edition of Shakspeare for an insignificant price.

—Messrs. Cassell & Co. will publish at once a new edition of William Robertson's "Life and Times of the Right Hon. John Bright," which has been brought down to date by a well-known American writer. The adding of the last lines to these chapters has been held back to await the death, which has been for so long anticipated. Mr. Robertson had especial advantages for writing this life of the great reformer and statesman, and it reads with all the absorbing interest that attaches to the well-written biography of a great man. The frontispiece of the book is a portrait of Mr. Bright taken from a recent photograph. A few proof impressions on India paper, suitable for framing, of the etching from the famous Oulesse portrait of John Bright, are offered for sale by Messrs. Cassell & Co. The original painting is owned by the Manchester Reform Club, by whose kind permission it was etched.

—Harper & Brothers will publish in May the second volume of Justin McCarthy's "History of the Four Georges."

—J. B. Lippincott Co. have nearly ready an anonymous story entitled "John Charaxes." Some who have seen the work think that its familiarity with Boston society, traditions, etc., the peculiar religious and political views occasionally expressed, and the scholarly style, point to the eminent lawyer, George Ticknor Curtis. This accords with certain rumors which have recently been afloat regarding his intention to write a novel bearing somewhat on the questions culminating in the civil war.

—Houghton, Mifflin, & Co. will publish next week Miss Howard's novel, "The Open Door;" an important religious work by Professor J. F. Weir of Yale, entitled "The Way: the Nature and Means of Revelation," a thoughtful book of the "New Theology;" "Prolegomena and an Index to In Memoriam," a book of notes on Tennyson's great poem; and a new edition of the reliable "Satchel Guide to Europe," carefully revised and printed from wholly new plates. They bring to the attention of the trade and the public Dr. Holmes's admirable memoir of J. L. Motley.

—Charles Scribner's Sons have just ready the second volume of Dr. M. R. Vincent's "Word Studies in the New Testament," treating of the writings of John. The purpose of the author of this work is to enable the English reader and student of the New Testament and of the Bible to get at the original force, meaning, and color of the significant words and phrases as used by the dif-

ferent writers. They have also just issued a volume of musical essays entitled "Chopin, and Other Musical Essays," by Henry T. Finck, author of "Romantic Love and Personal Beauty," who in this volume discusses such timely questions as German opera in New York, and the differences between the German and Italian vocal styles, as well as Chopin, Schumann, and the philosophical relation between music and morals. They will publish shortly J. A. Froude's new historical novel, to be entitled "The Chiefs of Dunboy." The period is the middle of the last century, and the characters include Irish exiles who have taken refuge and acquired influence in France, which they use as a base of supplies in their intermittent warfare against England. It will be issued in cloth and in paper bindings simultaneously with its appearance in England, being the first volume which the Scribners have issued for some time among their yellow-cover paper novels.

—The March number (No. 41) of the Riverside Literature Series (published monthly at 15 cents a number by Houghton, Mifflin, & Co., Boston) contains "The Tent on the Beach," and other poems, by John Greenleaf Whittier, with notes especially arranged for this edition. "The Tent on the Beach" tells of a summer holiday, spent by Whittier and his friends Bayard Taylor and James T. Fields; and in the poem, which by many is considered one of Whittier's best, some characteristics of these writers are very interestingly described. The other poems, among which may be mentioned "The Wreck of the Rivermouth," "The Grave by the Lake," "The Maids of Attitash," and "Abraham Davenport," are principally

"Legends and runes

Of credulous days, old fancies that lean
Silent from boyhood taking voice again,
Warmed into life once more, even as the tunes,
That, frozen in the fabled hunting horn,
Thawed into sound."

—A group of articles on fishing will begin in *Scribner's* for May, with a paper on "The Land of the Winanishie," by Dr. Leroy M. Yale of New York, and J. G. Aylwin Creighton of Quebec, who will describe a fishing-trip to Lake St. John after land-locked salmon. This region was recently made accessible to sportsmen by a new railway. Eugene Schuyler will publish in the same number some reminiscences of "Count Leo Tolstoi Twenty Years Ago." Mr. Schuyler was a visitor at Tolstoi's home, and had many long and intimate conversations with him, which are now for the first time published. The recollections will be concluded in the June number. Charles Eliot Norton of Harvard will contribute the end paper, the subject being "The Lack of Old Homes in America," and the associations and sentiments of which we are thereby deprived.

—T. Y. Crowell & Co. will publish at once a new edition, in paper covers, of "My Religion," by Count L. N. Tolstoi. This book, which was the first to attract attention to Count Tolstoi's remarkable personality, immediately caused more discussion than any other work of its kind that has been published since "Ecce Homo."

—The editor and publisher of the *International Ethnographica Archive*, not content with publishing yearly six magnificently illustrated and printed numbers, propose to issue supplements as occasion may offer. The first of these contains a learned description of the Indians of Guatemala, by Dr. Otto Stoll, whose studies on that country have won him so well deserved renown. The author treats fully, on the ground of his extensive observations and studies of literature, the social organization, religion, the practices of war, technology, and trade of the ancient inhabitants. The chapter on technology is admirably illustrated by two chromolithographs. The author describes the division of land among the gentes, — the chinamit, — the laws of marriage, terms of relationship, government, and the social position of the common men and of slaves. The chapter on religion is a very clear and succinct representation of what is known on this important subject, the famous Popol Vuh receiving its due attention. Psychologists will be particularly interested in the chapter on "Suggestion and Hypnotism," which phenomena are so widely spread among primitive people, but have not yet received their proper share of attention.

— The recent volume of the *Meddelelser om Groenland* contains two papers of great importance, which shed an entirely new light upon several ethnological questions referring to the Eskimo. The first of these papers is a collection of tales and traditions from Angmagsalik, on the east coast of Greenland, where the Danish expedition under Capt. G. Holm spent a whole winter; the second is a discussion of the vocabulary collected at this place by Dr. H. Rink. The tales are very much of the same character as those collected in other parts of Arctic America. Some of them are identical with tales from West Greenland and Labrador, while others are mainly new combinations of parts of well-known tales. The vocabulary is particularly interesting, on account of the great number of new terms for the most common objects. Most of these terms are descriptive names, the word which is used in all other dialects having become extinct. Thus, instead of "berry," the East-Greenlanders say "that what is picked;" instead of "hand," "limb;" for "tail," "end;" instead of "mother," "origin;" and many others. Similar words are used by the Eskimo shamans of other regions, but this is the only place where they have to a great extent superseded the common words. A great number of these words may have come into use, when, after the death of a man, people avoided mentioning him and his property; but others may simply have been taken from tales, and adopted for ordinary use. It is remarkable, that, in consequence of this custom, the East Greenland dialect has many features by which it differs from all other dialects. This fact must be considered a proof of a long isolation of this tribe.

— Fred H. Whipple, Detroit, Mich., will issue in June a complete directory of the electrical fraternity, including every person in every branch of the trade, and proposes to supplement this monthly, until the next annual number, with commercial reports embracing the doings of the electrical world up to date. These reports will be in the nature of confidential bulletins on the progress of the business world, confined entirely to matters electric, and will be sent only to annual subscribers.

— It is stated that throughout Asia Minor there are splendid opportunities for the introduction of machinery, the field at present being entirely unoccupied. There is a great abundance of water-power in the country, although at present it can hardly be said to be utilized. According to *The Timber Trade Journal*, there is not a board of any sort, or even a plank or beam, ever sawed there by any other power but that of the human hands: there is therefore a good opening for wood-working machinery. There ought also certainly to be an opportunity for agricultural-implement makers to introduce their products into Asia Minor, as such implements as are at present in use there are of the most primitive description. The spades and shovels are made of wood, each being cut out of one solid piece of timber. The ploughs are also of wood. Indeed, such implements cannot be called "ploughs" at all, as they are only pointed sticks, which comparatively seldom have even an iron-pointed cap upon the point which scratches, and it is supposed to turn over the soil. Manchester supplies most or perhaps all the cotton prints which are imported, and great quantities of which are used for clothing, divans, bedding, and such like purposes.

— Messrs. Kelso & Co., Glasgow, we learn from *Engineering*, have just completed the construction of the dynamometric apparatus in connection with the experimental tank being built at Spezzia for the Italian Government. This tank is similar in general details to that constructed by the British Government at Gosport, and by Messrs. William Denny & Brothers at Dumbarton, on the principle of Dr. Froude. The experimental tank at Spezzia is 500 feet in length, which is 100 feet more than that at Gosport, and the breadth is about 22 feet. The use of the tank is to determine the form of ship which shall have the least possible resistance at a certain speed, conforming to practical considerations, and to ascertain the relation of power to speed with the form of ship under consideration. The model having been constructed of paraffine, and faired by a specially designed machine, is tried in the tank by means of a dynamometric apparatus to measure the resistance of the models at varying speeds corresponding to the required speeds

for the full-sized ship. The apparatus is mounted on a carriage, which also supports the arrangement for measuring the rise and fall of the bow and stern of the model in its progress through the water. The chief novelty lies in the framework. The rails or platform on which the apparatus runs at Messrs. Denny's tank, are suspended by means of tie-rods from the joists of the tank; whereas at the new Italian tank the rails are placed at either side of the tank, which allows of the framework being so constructed as to afford an unobstructed view of the whole water behind, with the waves and currents. For accurately recording on a revolving cylinder the speed at which the model is running, electric arrangements have been supplied, the current being from a battery of Leclanché cells, carried on the lower table of the resistance truck. The circumferential travel of the cylinder is a function of the speed of the carriage supporting it, and on it is also recorded the resistance diagram, which is obtained by the extension of a helical spring attached to the dynamometer. There is an automatic arrangement for lifting and lowering the pens on the diagram and revolving cylinders. It may be added that the dynamometer of Messrs. Denny's tank was also supplied by Messrs. Kelso from plans by Mr. Froude.

— According to a parliamentary paper, entitled "Statement exhibiting the Moral and Material Progress and Condition of India," an abstract of which appears in the *Journal of the Society of Arts*, London, progress in education continues in India. The number of schools and colleges rose in 1887 to 127,381, as compared with 122,643 in the year 1886, and the total number of scholars to 3,358,042, as compared with 3,339,061. Of this total, only about 150,000 were girls; but the increase in the number of girl scholars has, during the last three years, been in a much larger ratio than the increase among the boy scholars. A new university was opened at Allahabad in 1887, and India now possesses five universities, all of which hold examinations and grant degrees. The number of candidates for admission to the universities rose from 13,254 in 1886, to 14,732 in 1887, and the number of admissions from 4,231 to 6,224. The number of students who gained university degrees in 1887 were 826 in art and science, 80 in medicine, 37 in engineering, and 193 in law. A large number of medical students obtained diplomas as hospital assistants in 1887, besides those who graduated in medicine. Of the Calcutta graduates in arts during 1887, two were women. The number of secondary or higher schools for boys has risen during the last five years from 3,932 with 215,731 pupils, to 4,160 with 404,189 pupils: during the same period the secondary schools for girls have risen from 190 with 6,366 pupils, to 357 with 24,904 pupils. The most important technical schools are the workshops at the great railways, at which some hundreds of apprentices, many of them holding scholarships or stipends from government or from local bodies, are learning mechanical engineering, smithy work, and carpentry. The number of pupils at engineering colleges and at art schools is very small, but the teaching of drawing and of surgery is being extended in most provinces. Now that primary and secondary schools are mostly under the control of municipal and local bodies, it is expected that technical teaching in the special handicraft or manufacture of each locality will be gradually increased.

— The American Statistical Association possesses a statistical library, the result of forty years' collection, which is designed as a depository for statistical works of every nature. At present the library is placed in rooms 31-33, Rogers Building, Massachusetts Institute of Technology, Boston. Its collection embraces not only the publications of the United States, but also many valuable reports issued by statistical bureaus of foreign countries. It also includes the very valuable statistical library collected by the former president, Dr. Jarvis, and bequeathed to the association upon his death, in 1884. It is believed that the collection and preservation of reports which admit of a classification according to statistical groupings, will be of great public service, and the association earnestly requests a generous co-operation in still further enlarging the library in such directions. Reports of vital and social statistics, registration reports, census documents, municipal reports, documents relating to public works, reports of trade, commerce, taxation, finance, insurance, industry, labor, health, crime, education, and religion, are especially desired.

—The *Quarterly Journal of Economics* for April opens with an article by F. W. Taussig, on "Some Aspects of the Tariff Question," in which the writer considers what effect the protective tariff has had in establishing, or helping to establish, certain industries. He shows that some branches of manufacture, such as that of silk goods, for instance, have been strongly stimulated by it; while other industries, among which the culture of flax fibre is conspicuous, have utterly failed, notwithstanding the high duty on the imported articles. Professor Taussig's conclusion is that international trade is really controlled, as the economists have always held, by the comparative cost of different commodities. Mr. Philip H. Wicksteed discusses "Certain Passages in Jevons's 'Theory of Political Economy,'" criticising some of Jevons's views, while agreeing with him as to the use of the mathematical method. The next article is on "Co-operative Savings and Loan Associations," by Seymour Dexter, and is mainly a description of such societies, which the author regards as one of the best forms of co-operation. He points out, however, that they have nowhere had very marked success except in Pennsylvania,—a fact which he attributes to certain superiorities in the laws of that State. Mr. James Bonar gives an abstract of a new theory of capital, recently advanced by the Austrian economist, Böhm-Bawerk. The problem is to account for interest, and the Austrian professor holds that it arises from the fact that future goods are not really so valuable as present goods otherwise identical. A dollar that I am to receive a year hence is not so valuable to me as a dollar in my pocket now; and therefore, if a man loans his capital, say for a year, he will demand at the end of that time not only the full value of his capital, but also an additional bonus, called interest. This theory is put forward as a new one; but we cannot see that it differs essentially from that of the English economists. They have always held that if a man loaned his wealth, or used it in production, so that he had to wait for its value to be returned to him, he would demand a recompense for waiting; and Professor Böhm-Bawerk's theory, as stated by Mr. Bonar, seems to be only a new expression of the same principle. The journal closes with the second part of Mr. A. B. Houghton's essay on "Italian Finances from 1860 to 1884,"—a paper containing a great amount of historical and statistical matter which will doubtless be useful to special students.

—A writer in the *Fortnightly Review* for March, speaking of the character of the Boers, says that it is considered perfectly correct to "do" the Boers. In the first place, money was perfectly useless to them, as they only keep it in gold in chests inside their bedrooms, and are constantly uneasy about it; second, the sons were only led into drinking and bad habits by having ready cash; and, lastly, it was impossible sometimes to deal with them otherwise. As an instance, there is a case where a Boer farmer asked for his farm, upon which gold had been discovered, the exorbitant sum of £50,000. If the buyer had refused, the obstinate man would never have abated the price; so he said he must think it over. Shortly afterwards he went to the bank and took out £6,000 in half-sovereigns, in twelve bags of £500 each. He drove up with these to the farmer's house, and took out ten of the bags, and said, "I have come to buy the farm."—"Have you brought £50,000?" said the farmer. "Well," said the Jew, "I have brought a lot of money; I will put it on the table." He then poured out the £5,000 in half-sovereigns. The farmer and his vrow looked on, and their eyes glistened as they looked at the table covered with gold. "How much is there?" said the vrow. "You had better count it," said the Jew. Of course, that was impossible; so the vrow said, "Could you not give us some more bags?"—"Well," said the Jew, "I must see if I have any more." Then he told the boy to bring one bag out, and he purchased the farm for £5,500.

—Messrs. Putnam have issued "Virgil's *Æneid*, the First Six Books," translated into English rhyme by Henry Hamilton. The narrative parts of the poem are in the ten-syllable couplet, and the speeches in a great variety of verse, changing with each recurring speaker. The object of this frequent change of form is to give variety to the English work; but as the original is all in one metre, and that radically different from any employed by Mr. Hamilton, there is nothing in the versification to remind us of Virgil. The

author complains that Conington's translation "by no means reproduces the sonorous effect of the Latin hexameter; but in what respect his own does so, we are unable to see. With several translations already in the field, we can see no good reason for a new one, unless it is fitted to supersede the others, which we fear is not the case with Mr. Hamilton's.

—What is claimed to be Miss M. G. McClelland's strongest story will be published by Cassell & Co. within a few days. It is called "Burkett's Lock." It is a story of the home; and as a picture it is believed that "Burkett's Lock" will make a sensation among the novel-reading public that they have not experienced in a long time, for it has a story in it, and a story well told. The scene is laid in Virginia, where Miss McClelland is so thoroughly at home, and her characters are drawn from the people, who are native to the soil.

—According to statistics published in *The Publishers' Weekly*, the following is an estimate of the new books published in Russia in 1888: philosophy, 26; education, 86; philology, 420; fiction, 818; geographical works, 211; history, 413; political science, 368; mathematics, 153; military, 202; natural sciences, 168; medical, 454; technological literature, 127; domestic economy, farming, etc., 121; books for children, 115; books for the people, 217; fine art, 139; miscellaneous, 448; total, 4,486. This does not include the literature published under ecclesiastical censorship, which naturally comprises theological books; nor are the books accounted for which did not circulate through trade mediums. It may therefore be assumed that the total number of books issued amounts in round numbers to five thousand volumes.

—The general outcome of a paper on "The Viscous Effect of Strains Mechanically applied, as interpreted by Maxwell's Theory," published by C. Barus in the *Philosophical Magazine* for February, is this: that the effect of strain of whatever kind, applied in sufficient intensity to homogeneous soft steel, is marked diminution of viscosity. Again, inasmuch as the underlying cause of viscous deformation is the occurrence of unstable configurations, the number of which is being reduced in the course of viscous motion, Maxwell's theory naturally suggests the applicability of exponential equations for the description of the time relations of such motion. From another point of view, it appears that the loss of viscosity experienced by a given metal, under action of a given kind of strain, may not inappropriately be used as a measure of its intensity. Finally, the curious observation, that, in all the cases given, loss of viscosity has taken place simultaneously with increase of hardness, is one of the suggestive results of the experiments made.

—W. J. Campbell, Philadelphia, will publish early in May a new improved edition of "Grant's Pennsylvania Reports," in three volumes.

—The Rev. John George Wood, the well-known naturalist, died recently in England. The deceased did perhaps more to popularize the study of natural history than any writer of the present age. He was the son of a surgeon who was at one time chemical lecturer at the Middlesex Hospital, London. He was born in London in 1827, and was educated at Oxford. His most important book was his "Natural History," in three volumes. Mr. Wood edited for some time the *The Boys' Own Magazine*, the pages of which periodical constantly contained work from his hands. He left no fortune, and a popular subscription in aid of his family has been started.

—"The Emperor of China," says the *Athenæum*, "has just issued orders for the preparation of a history of the Mohammedan rebellions in Yunnan, Kansuh, Shensi, and Turkestan, and five members of the Grand Council have been named as the committee to whom the work is intrusted. Similar official histories have already been written of the Taping and Nienfei revolts."

—The Liege Chamber of Commerce has recently set an example, says the *Journal de la Chambre de Commerce de Constantinople*, which might well be followed by other industrial centres. It has established a commercial museum on an entirely new system. This museum is divided into two sections. The first comprises the articles that Belgium is obliged to purchase from other

countries, while the second contains samples of all the articles which are manufactured in Belgium. A library and an information bureau are attached to this museum.

LETTERS TO THE EDITOR.

*Correspondents are requested to be as brief as possible. The writer's name is in all cases required as proof of good faith.

The editor will be glad to publish any queries consonant with the character of the journal.

Twenty copies of the number containing his communication will be furnished free to any correspondent on request.

The Robinson Anemometer.

So long as the anemometer law is purely empirical, it is doubtless largely a matter of individual taste that one should prefer to use a series of ratios whose values, even within the limits of ordinary usage, range between infinity on one hand, and 2.89 on the other, — a value which corresponds, according to *Science* of March 22 (p. 227), to a wind-movement of 25 miles per hour. Nevertheless occasion may be taken at some future time to point out a possible error into which one is easily led by use of this variable factor.

It seems, my "explanation of the effect of a uniform wind blowing across a whirler upon which an anemometer is being tested is very surprising;" indeed, I have wondered myself that so simple an explanation had not been suggested long ago. That it is "entirely untenable" cannot be admitted, since it is only made to appear so by my critic, who unfortunately omits from the very heart of the statement whose accuracy he questions, three very important words. Nothing more than this need be said. I am well aware, also, that "it has generally been considered that while these cups [of the anemometer] never respond instantly to the wind, and continually lag behind while the wind is rising, yet their momentum keeps them up, and about counterbalances this lagging while the wind dies down;" but that these effects about balance is exactly what does not occur, and therein is the novelty of the explanation I have suggested.

The substitute offered in *Science* of April 5 (p. 268) is based partly on an incorrect statement; namely, that a wind blowing directly at right angles to the path along which an anemometer is being carried will add its effect to that due to the motion of the anemometer. If the writer means that the sum of the two separate effects are to be taken, he is entirely wrong. It is a simple question of the resultant of two forces at right angles to each other, which is not the sum of the two separate forces. With this as a partial basis, the explanation is developed, and the astonishing conclusion reached that "the anemometer will be accelerated during more than three-fourths of the rotation [presumably of the whirler], and retarded during less than one-fourth of it." Had the author, in accordance with the principle of the parallelogram of forces, found the resultant of the two wind effects that act simultaneously upon the anemometer at each point of its path, and integrated or summed these up for a complete revolution of the whirler, he would doubtless have arrived at a much more accurate conclusion, — a conclusion that the ultimate resultant effect for a whole revolution "is only small in most cases, and is not very serious," as given in my original letter in *Science* of March 29; a view, moreover, that is entertained by Professors Dines, Stokes, and others who happen to have written on the question.

Even admitting that the explanation under discussion is correct, it does not account for the uniformity of the results obtained in England with the helicoid anemometer, which, being provided with a vane or tail, always presented its front directly to the resultant wind. The Robinson anemometer, from its construction, has no need of a tail, and the two instruments are circumstanced exactly alike so far as being equally subject to the resultant wind. It is presumed throughout this and previous papers that the axis of the Robinson anemometer is vertical or nearly at right angles to the plane of rotation of the whirler. The analysis of the problem is a little different when the axis is inclined more or less to the vertical, but the final result is practically the same.

Having several weeks ago submitted a paper containing in detail the various experiments and results that led to the development of

the explanation given in *Science* of March 29, I do not desire to cite here any experimental confirmation of the theory, nor do I consider that the results given by Professor Hazen in any way disprove the theory. Why one should expect to be able to use the same formula for cone-shaped paper cups as had been found applicable to hemispherical metal cups, or should be surprised at a difference of twenty per cent less wind-velocity, does not appear.

Following the example of Professor Hazen, I intend to try some experiments with hemispherical paper cups, and have thus far completed a set; but the pressure of other duties has not afforded me the opportunity to do more as yet.

C. F. MARVIN.

Washington, D.C., April 8.

The Metric System and Professional Teaching.

THE committee appointed at the Cleveland meeting to consider the relations of chemistry to public instruction, naturally have their attention called to the metric system of measures. No doubt the familiarity of the public with this system has much increased since 1866, when the Act of Congress was passed making it legal; but recent conversations with parties who might be supposed well posted on the subject show some views that appear to the writer incorrect, and adapted to retard the adoption of a much-needed reform.

A very prominent teacher of chemistry said he was not an advocate of its general use, and that no time would be saved in the instruction of children by such adoption. The Metric Bureau, in their leaflet, stated that "a year of the school-life of every child would be saved by the adoption of this system." This statement was made by teachers. I do not know its basis; but there are, in the English system of tables we use, about fifty factors to be memorized. As there is but one factor in the metric system, and that the same as our system of numeration, necessarily fifty times as much time is required to learn English measures as metric. If the Society for Psychological Research can tell us the average time required to memorize an idea, we should then know the saving of time in instruction, that would follow the adoption of the metric system.

An apothecary assured me that the adoption of parts by weight in the new pharmacopœia, with which he connected in some way the metric system, had, in his judgment, done great harm to the drug business: for, he said, the wholesale manufacturers put on the outside of their bottles that one part of this extract, etc., with nine parts distilled water (or required proportions), would make ten volumes of the officinal strength. The extreme simplicity of this process, my friend argued, reduced the drug business, so far as intellectual qualifications are concerned, below the grocer, and the metric system was somehow held responsible.

The metric system is in universal use by chemists. The arts of medicine and pharmacy are dependent on chemistry for their materials and their processes. As matters now stand, every student in the colleges of these arts is obliged to learn two new tables of measures, — apothecary and metric; for I assume that all professors of chemistry teach the metric, and some professors of materia medica also. In other schools the chair of chemistry teaches one, and the chair of materia medica the other system.

Is it not time to inquire if this is a rational condition of things? It will not do to say the apothecary weight is learned in the primary school. The metric is taught also, at the present time. Both are usually forgotten before the student matriculates. Neither can it be said that we break away from the system of our English cousins, for our fluid measures are not the same as theirs, now that they use the imperial gallon. There remains the single argument against the metric system in our professional schools, that it is not in general use by physicians. Those who do use it find the gram a most convenient unit. The difficulty of inducing a large body of men to change some of their basic elements of thought seems to be the greatest obstacle to a beneficial improvement.

Now, why not let the old doctors use the old system, but teach the graduates only the new; then add to the pharmacy laws a clause requiring every druggist to provide himself with a set of metric weights, making this condition as indispensable as a diploma? At present, when a prescription is presented in the met-

ric system, most druggists translate it into apothecary weight, and feel aggrieved that they are put to extra trouble thereby. If they had the weights, very many would use them sufficiently to become acquainted with their practical advantages, and thereby add their influence to the advancement of the reform. At present many who acknowledge the advantages of the metric weights, and would gladly see them used, do not have quite the energy required to actively push the change.

It is not understood by some that the object is to entirely supplant the present weights, not to make an addition to our stock. It seems very hard for them to realize that the particular set of arbitrary quantities, in which they happen to think, will in a few years pass into history along with cubits and sesterces, and be equally forgotten. It will be greatly to the advantage of all concerned to hasten this time as much as possible. Just now it seems as if the change was taking place rapidly in some of the mechanical arts; and the following quotation from the *Journal of Engineering Societies* is so apropos, that we add it as summing up the whole matter: "The Western architects prefer decimal subdivisions, because of greater ease in written operations, greater certainty and rapidity in mental operations with numbers of measure, decreased liability to error in figuring drawings (prescriptions), and a general saving of time and anxiety."

How well the above statement would apply to medicine and pharmacy! Simply let all teachers of pharmacy and materia medica agree to omit entirely all reference to the apothecary system of weights and measures, and adopt the law above stated, and the metric system will come into use, and the other die without a struggle.

WM. H. SEAMAN, M.D.

Howard Univ., Washington, April 3.

Platinum in British Columbia.

IN connection with the article on platinum in *Science* for March 29, it may be of interest to some of your readers to know that platinum is found in association with gold in placer deposits in a number of localities in British Columbia, and that the most important occurrence of that metal yet met with in North America, so far as I am aware, is that of the Tulameen and Upper Similkameen in that province.

In the "Mineral Resources of the United States for 1887," Mr. David T. Day states that in consequence of inquiries set on foot for crude platinum, a total quantity of 448 ounces was obtained in that year in the United States. Part of this amount was purchased in Oregon, and part is stated to have been derived from British Columbia. This latter portion, no doubt, came from the particular region to which allusion is here made; for, though found in other places in British Columbia, it is here only that the quantity has been such as to induce the miners to collect and market it. The total product of the Upper Similkameen and Tulameen district in 1887 is estimated at from 1,400 to 2,000 ounces, and in 1888 at 1,500 ounces.

Placer gold-mining has been carried on in an intermittent manner in the district in question for many years, the gold found being generally scaly or "fine," and being invariably accompanied by a certain quantity of similarly "fine" platinum. In 1885, however, "coarse" gold was discovered on Granite Creek, a tributary of the Tulameen, and in association with it similarly "coarse" platinum, in grains and pellets which are sometimes as large as a pea; the platinum in some "claims" being present in quantity equal to half that of the gold obtained, by weight. Since this discovery, the platinum, which was formerly thrown away, has been kept and sold separately, the price obtained averaging about three dollars an ounce.

As is usually the case, the platinum here found is alloyed with several other metals of the same series, and with copper and iron. The metals of the platinum series include osmiridium (in considerable quantity) with palladium, rhodium, and osmium to lesser amounts (according to analyses by Mr. G. C. Hoffmann, *Transactions of the Royal Society of Canada*, vol. v. sect. iii. p. 17; *Annual Report of the Geological Survey of Canada*, 1887, p. 5, T.).

During the summer of 1888, I had an opportunity of examining the localities of occurrence of platinum here described, and, without

entering into particulars, I may state that its association and distribution point very strongly to a mass of coarse intrusive diorite, which contains much magnetite in a disseminated form as well as in veins reticulating through it, as the source of the platinum. In consequence of the extreme rarity of this metal in its original matrix, this subject appears to be one of particular interest, and it is intended further to investigate it.

GEORGE M. DAWSON.

Geological Survey of Canada, Ottawa, April 5.

The Age of the Denver Formation.

I HAVE read with much interest the article in the April number of the *American Journal of Science and Arts*, by Mr. W. Cross, on a formation which occurs near Denver, Col., which he calls the "Denver formation." It appears to be stratigraphically distinct from the Laramie formation, from which it is separated by an intervening deposit, the Willow Creek bed. Paleontological evidence is available from three sources,—the plants, the *Mollusca*, and the *Vertebrata*. The plants according to Ward, and the *Mollusca* according to White, do not differ from those of the Laramie, and most of the *Vertebrata* have the same character. The formation has, on the other hand, yielded some fossils which have been referred to the mammalian genus *Bison*, and described and figured under the name of *B. alticornis* (*American Journal of Science and Arts*, 1887, p. 323) by Professor O. C. Marsh. On the strength of this determination, Professor Marsh identifies the horizon with the pliocene.

This was the first determination made in recent years. When subsequently dinosaurian bones were reported from these beds, a great deal of discussion was aroused, and the persistence of this mesozoic type of *Reptilia* into cenozoic time was proposed and maintained in some papers of a fugitive character.

Several years ago I had the opportunity of examining remains of *Vertebrata* from near Denver and Golden, and they were clearly dinosaurian, and of the types which belong to the Laramie system. How is it possible, then, that a species of *Bison*, a pliocene genus, could occur in the same bed? The explanation is as follows.

In 1875 I published an account of the *Dinosauria* obtained by me east of Denver, in the Laramie formation. They included three genera,—*Hadrosaurus*, and two new ones, *Cionodon* and *Polygonax*. Subsequently, in 1878, I described parts of the skeleton of a dinosaur from near the Judith River, Montana, which was furnished with robust horn-cores. All of these types were figured in the "Final Report and Bulletin of the United States Geological Survey of the Territories." Thinking that this horned reptile would be found to belong to one or other of the nine genera of *Dinosauria* already described by Leidy and myself from the Laramie, I refrained from naming it.

Material recently obtained and described by Professor Marsh goes to show that the horned dinosaurs belong to the genus *Polygonax*, Cope; and not only this, but that the *Bison alticornis* belongs to it also. That the latter species is not a mammal is indicated by the characters of the brain-case figured by Marsh.

Thus is removed the only obstacle to the reference of the Denver and Willow Creek formations to the Laramie system.

E. D. COPE.

Philadelphia, April 4.

Platinum in Place.

IN *Science* for March 29, p. 232, the finding of platinum *in place* is commented on. The following extract from Wurtz's "Dictionnaire de Chimie" (vol. ii. p. 1035) may be interesting:—

"Le platine a été trouvé en place par M. Boussingault dans les filons aurifères de Santa-Rosa de Osos en Colombie. Ce sont des filons de quartz hyalin et de limonite traversant une roche de syénite ou de diorite; en Sibirie, MM. G. Rose et Leplay ont toujours trouvé le platine dans les vallées ouvertes au milieu des roches serpentineuses."

Dana ("A System of Mineralogy," 5th edition, p. 11) says, "In Nische Tagilsk, it [platinum] has been found with chromite in serpentine."

W. G. BROWN.

Washington and Lee Univ., Lexington, Va., April 3.

GUARANTY INVESTMENT COMPANY

CAPITAL \$250,000.

Offices: Atchison, Kan. 191 Broadway, New York, 222 Walnut St., Phila.

Hon. ALBERT H. HORTON (Chief Justice, Kansas Supreme Court), Topeka, Kan., Pres't.

7% Guaranteed Farm Mortgages 7%

The Guaranty Investment Company makes loans upon fertile farms in the choicest portions of Kansas and Nebraska and has adopted the policy of sending a Committee of its Investors each year to examine its loans and methods of business.

The Committee this year consisted of PROF. A. H. BERLIN, Principal of the High School Montrose, Pa., and MAJ. THEODORE L. POOLE, Ex-U. S. Pension Agent, Syracuse, N. Y. Both of these gentlemen are persons of the highest character and have the confidence of the Communities in which they reside.

The Committee has recently returned and has made a very interesting Report upon the general development of Kansas and Nebraska as well as the business of the Company. The Company will be glad to send this Report to any address.

The following names are taken from the long list of Investors in our Mortgages:

(See if Some Friend of Yours is not in the List.)

William A. Cauldwell, 59 Liberty St., N.Y.
Palmer Cox, 658 Broadway, N.Y.
Rev. Jos. H. Rylance, D.D., 11 Livingston Place, N.Y.
Rev. Brady E. Backus, D.D., 376 West 28th St., N.Y.
Rev. R. M. Somerville, 126 West 45th St., N.Y.
Dr. Robert A. Murray, 234 West 23d St., N.Y.
Dr. James P. Tuttle, 156 West 41st St., N.Y.
H. Edwards Rowland, 218 Fulton St., N.Y.
Irving H. Tift, Esq., 271 Broadway, N.Y.
Prof. D. G. Eaton, 55 Pineapple St., Brooklyn, N.Y.
Dr. E. P. Thwing, 156 St. Marks Ave., Brooklyn, N.Y.
Dr. C. G. Miles, Greenport, N.Y.
John V. N. Bergen, Port Jefferson, N.Y.
Benj. W. Stilwell, Yonkers N.Y.

R. C. Coleman, Goshen, N.Y.
Mrs. Samuel Carlisle, Newburg, N.Y.
Dr. C. C. Bartholomew, Ogdensburg, N.Y.
Rev. Nelson Millard, D.D., Rochester, N.Y.
Rev. Horace G. Hinsdale, D.D., Princeton, N.J.
Dr. Charles M. Howe, Passaic, N.J.
George A. Skinner, 5 Railroad Place, Newark, N.J.
Dr. Edwin M. Howe, 85 Halsey St., Newark, N.J.
Dr. H. G. Buckingham, Clayton, N.J.
Dr. Martin Cole, Jr., Hainesville, N.Y.
Mortgage Trust Co. of Pa., Philadelphia, Pa.
Miss Mary Miller, 1230 Spruce St., Philadelphia, Pa.
Henry D. Biddle, 312½ Walnut St., Philadelphia, Pa.

Dr. Calvin C. Halsey, Montrose, Pa.
Rev. William Baldwin, Great Bend, Pa.
Gen. William Lilly, Mauch Chunk, Pa.
Second Nat. Bank, Mauch Chunk, Pa.
Enos E. Thatcher, West Chester, Pa.
Mrs. Townsend Pore, Scranton, Pa.
Rev. Burdett Hart, D.D., New Haven, Conn.
Dr. Frank H. Wheeler, New Haven, Conn.
Charles R. Christy, Stamford, Conn.
Mrs. Catharine P. Fuller, Woodmont, Conn.
Miss Jessie Henderson, Lenox, Mass.
Dr. M. J. Halloran, Worcester, Mass.
Albert Walker, Bennington, Vt.

Address for Report and Monthly Bulletin

HENRY A. RILEY, General Eastern Manager, 191 Broadway, N.Y.

GEOLOGY AT A GLANCE.

Ives Strata Map of part of the United States of America and Canada,

In which the Architecture of the Earth's Crust is Graphically Exhibited, Illustrating Fundamental Facts alike of

STRUCTURAL GEOLOGY AND PHYSICAL GEOGRAPHY.

The Strata Map is a device for the more efficient teaching of Physical Geography and Elementary Geology in Schools. It consists of a series of Ten Superimposed Maps, of DIFFERENT COLORS, representing the several geological formations of the district, enclosed in a glazed frame, the whole hinged to ad-

mit of examination in detail. By its means *superposition, denudation, and outcrop* of strata are graphically exhibited, with the phenomena of *escarpments, outliers, initiars, dip, strike, conformability, &c.*, and the Cards may be bent to show *synclinal or anticlinal* folds.

OPINIONS OF EMINENT GEOLOGISTS.

Yale University,

"Well fitted for the use of instruction in the science."

Professor James D. Dana,

Professor Addison E. Verrill,

"It will be of very great advantage in the teaching of geology."

Professor N. S. Shaler,

Harvard University,

"An extremely useful adjunct to our means of illustration."

President D. C. Gilman,

Johns Hopkins University,

"Wherever American geology is taught your map should be a part of the apparatus."

Professor Geo. A. Koenig,

Pennsylvania University,

"The map will be of special use in schools, which can only devote a short time to the study of Geology."

Professor Alexander Winchell,

Michigan University,

"It seems to me that the device will commend the study of Geology to many persons who might otherwise regard the subject as difficult and uninviting. The work prepared by Mr. Ives ought to be used extensively in American schools."

Professor H. Shaler Williams,

Cornell University,

"A valuable aid to teachers of geology as a means of graphically representing the grand facts of stratigraphy in the Eastern United States."

Professor J. S. Newberry,

Columbia College, New York,

"A valuable aid in teaching geology, giving as it does to the student a clear idea of the superposition of the different geological systems at a glance."

Professor C. H. Hitchcock,

Dartmouth College, Hanover, N. H.,

"Am satisfied that its use will greatly assist students to understand the geological structure of the country."

SIZE 30x24 INCHES. PRICE \$17.50.

Academy of Natural Sciences of Philadelphia.

Professor Angelo Heilprin,

"The representation of Strata, as imposed one upon the other, by means of cardboard is certainly a good plan, for apart from rendering more intelligible the general expressions of the Map, it permits of ready alteration and the possibility of constantly bringing the map up to date, in other words to make it conform to more recent discoveries."

Boston Society of Natural History.

Professor Alpheus Hyatt,

"Your map representing superposition and the various phenomena of geological science, so far as the distribution of rocks on this continent is concerned, has greatly interested me. I think that in the hands of a good teacher it would prove an efficient and useful adjunct in the teaching of geology."

American Museum of Natural History.

Professor R. P. Whitfield,

"In the direction of a want long felt by Teachers of Geology and will undoubtedly be appreciated by them as well as by the student."

U. S. Geological Survey,

Major J. W. Powell, Director,

"After examination I am able to state that the work has been executed with care and fidelity, and I believe it will be a valuable aid to teachers."

New York State Survey,

Professor James Hall, State Geologist

"I believe that maps constructed upon this method would be extremely useful in the hands of competent teachers."

Pennsylvania Survey,

Professor J. P. Lesley, State Geologist,

"A piece of new and useful apparatus for teaching geology, by representing to the eye of the student the areas of superimposed formations. I cordially recommend it to teachers and students."

New Jersey Survey,

Professor Geo. H. Cook, State Geologist,

"It is very neatly done and must prove a great help to intelligent teaching and studying of Geological Science."

PUBLISHED AT THE OFFICE OF "SCIENCE," 47 LAFAYETTE PLACE, NEW YORK, N. Y.

Publications received at Editor's Office, April 1-16.

- CAMPBELL, Helen. Under Green Apple Boughs. (Ticknor's Paper Series, No. 54.) Boston, Ticknor. 272 p. 16c. 50 cents.
CHAMBERS'S ENCYCLOPEDIA. New ed. Vol. III. Caithth to Dion. Philadelphia, Lippincott. 328 p. 8c. 8c.
DOLARO, Selina. Bella-Demonia. Chicago, New York, and San Francisco, Belford, Clarke, & Co. 265 p. 16c.
FIGUEROA, L. L'Année Scientifique et Industrielle, 1888. Paris, Hachette. 636 p. 12c. (New York, Christern.)
FOOTE, A. R. Economic Value of Electric Light and Power. Cincinnati, Robert Clarke & Co. 191 p. 12c. \$1.
GROH, I. W. Did Man Fall? The Location and Topography of the Garden of Eden a Fact Is the Garden also a Fact? \$5,000 Reward. New York, Truth Seeker Co. 21 p. 16c. 10 cents.
HAMILTON, H. Virgil's Aeneid. The First Six Books translated into English Rhyme. New York and London, Putnam. 127 p. 12c.
HARPER'S FIRST READER. In 2 parts. New York, Harper. 144 p. 12c.
Second Reader. In 2 parts. New York, Harper. 203 p. 12c.
Third Reader. In 2 parts. New York, Harper. 316 p. 12c.
Fourth Reader. In 2 parts. New York, Harper. 450 p. 12c.
LEITCHWORTH, W. P. The Insane in Foreign Countries. New York and London, Putnam. 374 p. 8c. 8c.
LIMITATIONS of Toleration, The: A Discussion between Col. Robert G. Ingersoll, Hon. Frederic R. Couderc, and Ex-Gov. Stewart L. Woodford. New York, Truth Seeker Co. 44 p. 16c. 10 cents.
MARTIN, T. C., and WETZLER, J. The Electric Motor and its Applications. 2d ed. New York, W. J. Johnston. 282 p. 4c.
NATIONAL ECONOMIST, The. Vol. I. No. 1. Washington, Nat. Econ. Publ. Co. 16 p. f. \$1 per year.
NATIONAL Educational Association, Proceedings of the Department of Superintendence of the, at its Meeting in Washington, Feb. 14-16, 1888. Washington, Government. 165 p. 8c.
NEWELL, Jane H. Outlines of Lessons in Botany. Boston, Ginn & Co. 140 p. 16c.
O'BRIEN, D. A Laboratory Guide in Chemical Analysis. 2d ed. New York, Wiley, 237 p. 5c. 5c.
SALZUS, E. A Transaction in Hearts. New York, Chicago, and San Francisco, Belford, Clarke, & Co. 188 p. 16c.

Wants.

A YOUNG MAN can have lucrative engagement, not only a fixed salary, but according to his work accomplished in travelling for SCIENCE. A personal interview invited.

N. D. C. HODGES, 47 Lafayette Place, New York.

Any one who will have the following blank filled out by a responsible Newsdealer, and mailed to us, will be allowed a three months' subscription to Science.

N. D. C. HODGES, 47 LAFAYETTE PLACE, NEW YORK.

1889.

To the News Company.

You may add to my regular order five copies of SCIENCE each week (returnable).

"The Week, one of the ablest papers on the continent."—Descriptive America.

ENLARGED AND IMPROVED.

THE WEEK:

A Canadian Journal of Politics, Literature, Science and Arts.

PUBLISHED EVERY FRIDAY.

\$3.00 per Year. \$1.00 for Four Months.

THE WEEK has entered on its SIXTH year of publication, greatly enlarged and improved in every respect, rendering it still more worthy the cordial support of every one interested in the maintenance of a first-class literary journal.

The independence in politics and criticism which has characterized THE WEEK ever since its first issue will be rigidly maintained; and unceasing efforts will be made to improve its literary character and increase its value and attractiveness as a journal for the cultured home. Many new and able writers are now, or have promised to become, contributors to its columns, and the constant aim of the Publisher will be to make THE WEEK fully equal to the best literary journals in Britain and the United States.

As heretofore, PROF. GOLDWIN SMITH will, from time to time, contribute articles. London, Paris, Washington and Montreal letters from accomplished correspondents will appear at regular intervals. Special Ottawa Letters will appear during the sessions of Parliament.

THE WEEK in its enlarged form will be the same size as "Harpers' Weekly," and the largest paper of its class on the continent.

SEND FOR FREE SAMPLE COPY.

C. BLACKETT ROBINSON, Publisher, 5 Jordan St., Toronto.

Old and Rare Books.

A. S. CLARK, Bookseller, 34 PARK ROW, NEW YORK CITY.

A Gleaner in the By-ways of Literature. Results of Gleaning found in Catalogues issued from time to time.

CATALOGUE NO. 27 NOW READY.

BACK NUMBERS and complete sets of leading Magazines. Rates low. AM. MAG. EXCHANGE, Schoharie, N.Y.

H. WILLIAMS, Dealer in Old Magazines, Reviews, &c. Scientific periodicals a specialty. 39 Macdougall St., N.Y.

SCIENCE CLUBBING RATES.

Table with columns: 10% DISCOUNT, Year's Subscription, With Science, With The Swiss Cross. Lists various journals and their rates.

N. D. C. HODGES, 47 Lafayette Place, New York.

C. & C. ELECTRIC MOTOR COMPANY.

Electric Motors
FOR
Arc and Incandescent Circuits, Most Economical Motor on the Market.
Regulation Perfect.
Motors Designed for all Power Purposes.

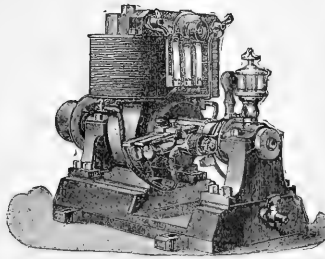

OFFICE and MANUFACTORY:
402 and 404 Greenwich Street, New York City,
New England Office, 19 Pearl St., Boston.
Philadelphia Office, 301 Arch St.
Western Office, 139-141 Adams Street Chicago.
Southern Office, 25 Carondelet Street, New Orleans.

PATENTS.

During April and May my fees due only on allowance if desired. Write
WM. H. BABCOCK,
513 Seventh St., Washington, D.C., P. O. Box 220.
Formerly Examiner in Patent Office.
THIRTEEN YEARS' PRACTICE.

Schools.

CONNECTICUT, NEW HAVEN.

MRS. CADY'S SCHOOL FOR YOUNG LADIES.
Prepares for Smith and Wellesley, and admits to Vassar by Certificate. Circulars. Early application necessary.

NEW JERSEY, PLAINFIELD.

THE CHESTNUTS.—Parents with daughters to educate, or orphan girls with companion, may find a comfortable home, with school instruction by applying to Miss E. E. Kenyon.

INDIANA, TERRE HAUTE.

ROSE POLYTECHNIC INSTITUTE.—A School of Engineering. Well endowed, well equipped departments of Mechanical and Civil Engineering. Electricity, Chemistry, Drawing. Extensive Shops & Laboratories. Expenses low. For catalogue address T. C. Mendenhall, Pres.

Brokers and Auctioneers.

R. ELLIS & CO.

BUSINESS, HOTEL AND PATENT BROKERS,
AUCTIONEERS, ETC.

No. 176 BROADWAY,

Room 46. **New York.**

CLIENTS Advised free of charge.

J. P. TRAVER & CO.,

General Auctioneers,
Real Estate and Business Brokers,
OFFICE, 23 PARK ROW,

OPPOSITE POST OFFICE, (ROOMS 14 & 15.) **New York.**

Mortgages Foreclosed. Cash Advanced on Consignments
Property of Every Description Bought, Sold
and Exchanged.

Readers of Science

Corresponding or visiting with Advertisers,
will confer a great favor by mentioning this paper.

Scientific Apparatus.

J. GRUNOW,

621 Sixth Avenue, New York.
Established 1852.

MAKER OF

Microscope Stands,
Oil Immersion Objectives and Abbe Condensers for Bacterial and Histological work, of Objectives, Camera Lucida and other accessory apparatus.

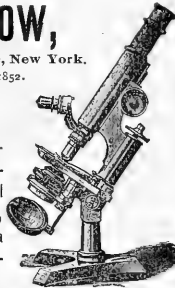

IMPROVED OIL LIGHT MAGIC LANTERNS.

Also Lime and Electric Light Apparatus, and mechanical, plain, and fine colored views.

J. B. COLT & CO., Manufacturers,
No. 16 BEEKMAN STREET, NEW YORK.

MAGIC Stereopticons and the Best Views for Public, Church, Home, and Scientific Exhibitions. Best apparatus, new views. Largest stock. Reduced prices. 24 Years' Practical Experience. Illus. Catalogue Free.

GEO. H. PIERCE,
136 S. Eleventh St., Philadelphia, Pa

ELECTRICAL TESTING BUREAU,

Johns Hopkins University, Baltimore, Md.
Resistance Coils and Boxes Compared.
Am meters and Volt meters calibrated.
Condensers standardized.
Primary and Secondary Batteries Tested.
Efficiency of Dynamos and Motors Determined.
Insulation of Cables and Wires Tested.
Etc., Etc.
Circulars describing Methods Used, Prices, Etc., sent on Application.
Address as above.

MORRIS EARLE & CO.

SUCCESSORS TO

R. & J. BECK,

1016 Chestnut Street Phila

Microscopes and all Accessories and Apparatus. Photographic and Photo-Micrographic Apparatus and Outfits.

Spectacles, Eye Glasses, Opera and Marine Glasses, etc.

Illustrated Price List mailed free to any address. Mention Science in corresponding with us.



E. & H. T. ANTHONY & CO.

591 Broadway, N.Y.

Manufacturers and Importers of PHOTOGRAPHIC INSTRUMENTS,

Apparatus and Supplies of every description. Sole proprietors of the Patent Detective, Fairy, Nov

el, and Bicycle Cameras, and the Celebrated Stanley Dry Plates.

Amateur Outfits in great variety, from \$5.00 upward. Send for Catalogue or call and examine. More than 40 years established in this line of business.

WHITAL'S PLANISPHERES OR DI-RECTORY OF THE STARRY HEAVENS name and locate all Stars. Constellations, and Planets visible at any given minute of time. Should be used by every one. Ask your stationer, or address WM. T. COOPER, Manager, 307 Race St., Philadelphia, Pa.

Readers of Science

Corresponding or visiting with Advertisers, will confer a great favor by mentioning this paper.

A TEMPORARY BINDER

for Science is now ready, and will be mailed postpaid on receipt of price.

Half Morocco - 75 cents.

This binder is strong, durable and elegant, has gilt side-title, and allows the opening of the pages perfectly flat. Any number can be taken out or replaced without disturbing the others, and the papers are not mutilated for subsequent permanent binding. Filled in this binder, Science is always convenient for reference.



N. D. C. HODGES,

47 Lafayette Place, N Y

**Arnold,
Constable & Co.**
**SPRING STYLES
DRESS FABRICS.**

Plain and Hair-Line Batiste Cloths,
Printed Laines, Fancy Mohairs,
Cheviots, Tweeds,
for Steamer and Travelling Dress.
Checked and Striped Suitings,
Broche and Embroidered Robes,
Cashmeres d'Ecosse, Henrietta Cloths,
IN NEW COLORINGS.
FOR STREET AND EVENING WEAR

Broadway & 19th St.
New York.

BLACK SILK WARP

Henrietta Cloth.

We have opened a new invoice of
Black Silk Warp Henriettas, subject
to slight manufacturer's imperfections,
at the following prices:
\$1.00 per yard, regularly **\$1.25**

1.10	"	"	1.35
1.25	"	"	1.60
1.50	"	"	1.75
1.60	"	"	1.85
1.65	"	"	2.00
1.75	"	"	2.25

These goods are similar to the
line sold by us last Fall. They are
from one of the most celebrated
makers in England, and of far
more than usual value.

Samples sent on request.

JAMES McCREERY & CO.
BROADWAY AND ELEVENTH STREET,
NEW YORK.

IMPROVING
THE
MEMORY PICK

and facilitating the acquirement of knowledge by
lectures and correspondence. Classes for mng-
"MEMORY and its Doctors," from Simonides to
"Loisette," mailed for 10 cents.
DR. PICK, 24 Union square, N. Y. City.

**FOOD
ADULTERATION**

And its Detection. With photomicrographic plates and
a bibliographical appendix. By J. P. Battershall, 328
pages, 8vo, cloth. Price, \$3.50. Circulars and Catalogues
on application. E. & F. N. SPON,
12 Cortlandt St., New York.

**KIMBALL'S
STRAIGHT CUT
CIGARETTES**

Unsurpassed in quality.
Used by people of refined taste.
Highest award at Brussels, 1888.
The finest smoking mixtures are of
our manufacture.
Fifteen First Prize Medals.
WM. S. KIMBALL & CO.,
Rochester, N. Y.



BRANCH AT 728 CHESTNUT ST.
PHILADELPHIA, PA.

JOHN HASTINGS = Pres't.
A=R=HART = Genl. Manager.
JOS=TRIPP = V. Pres't.

**ENGRAVING FOR
ALL ILLUSTRATIVE
AND ADVERTISING
PURPOSES**

67-71 PARK PLACE
NEW YORK

**THE CHEQUE BANK
LIMITED.**

ESTABLISHED IN LONDON, 1873.

CHIEF OFFICE, 4 Waterloo Place, Pall
Mall, London.

TRUSTEES:

The Right Honorable JOHN BRIGHT, M.P.
The Right Honorable EARL BEAUCHAMP.
Bankers: Bank of England.

The Capital of the Bank and its Guarantee Fund of 50%
is invested in Government Securities.

The Bank does not discount Notes or Bills, nor speculate,
but loans its Deposits against Government Securities,
and thus the Cheque Bank Cheques EQUAL TO
CASH—as Bank of England Notes are.

The Cheque Bank issues Cheques singly or in books
from ONE POUND upwards, for the use of Travelers,
and for others remitting money to Europe, available in
every town in England, Scotland, Ireland, and Wales.
In every town of Europe, and all other parts of the world.
Cheque Bank Cheques are accepted as Cash by all
the British Government Offices.

VISITORS TO THE PARIS EXHIBITION this
summer can get the Cheque Bank Cheques cashed at 50
Banking Houses in Paris.

Travelers and others holding Cheque Bank Cheques
can have their mail matter addressed to them, care of the
Cheque Bank, London, who will take charge of the same
and forward to any address.

For Hand-Book containing List of upwards of 2000
of the principal Banking Houses throughout the World
who Cash the Cheque Bank Cheques, and for all information,
apply to the CHEQUE BANK.

CHEQUE BANK, Limited,
UNITED BANK BUILDING,
2 Wall St., New York.

E. J. Mathews & Co., Agents.

REFERENCES BY PERMISSION:
JNO. W. MACKAY, Esq., President Commercial Cable
Company, Mackay-Bennett Cables, New York.

F. O. FRENCH, Esq., President Manhattan Trust Co.,
New York, and others.

KNABE
PIANOFORTES.

UNEQUALLED IN
Tone, Touch, Workmanship and Durability.

WILLIAM KNABE & CO.
NEW YORK: No. 112 Fifth Av., above 16th St.
BALTIMORE: Nos. 22 and 24 E. Baltimore St.
WASHINGTON: No. 817 Market Space, Penn. Av., near 9th St.



Greatest inducements ever offered.
Now's your time to get
up orders for our celebrated
Teas and Coffees, and secure
a beautiful Gold Band or Moss
Rose China Tea Set, Dinner Set,
Gold Band Moss Rose Toilet Set, Watch, Brass Lamp,
or Webster's Dictionary. For full particulars address
THE GREAT AMERICAN TEA CO.,
P. O. Box 289, 81 and 83 Vesey St., New York.

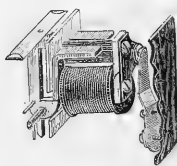

A
★
DROP
IN THE
PRICE
★
OF

GRAVITY

**DROP
ANNUNCIATORS.**

DON'T FORGET THE
DUST-PROOF BELLS.

HAZAZER & STANLEY,
32 Frankfort Street, N. Y.

**SCOTT'S
EMULSION**
OF PURE COD LIVER OIL
AND HYPOPHOSPHITES

Almost as Palatable as Milk.

Containing the stimulating properties of the
Hypophosphites combined with the Fattening
and Strengthening qualities of Cod Liver Oil,
the potency of both being largely increased.

A Remedy for Consumption.
For Wasting in Children.
For Scrofulous Affections.
For Anæmia and Debility.
For Coughs, Colds & Throat Affections.

In fact, ALL diseases where there is an inflammation of the Throat and Lungs, a
WASTING OF THE FLESH, and a WANT
OF NERVE POWER, nothing in the world
equals this palatable Emulsion.

SOLD BY ALL DRUGGISTS.

SCIENCE

[Entered at the Post-Office of New York, N.Y., as Second-Class Matter.]

A WEEKLY NEWSPAPER OF ALL THE ARTS AND SCIENCES.

SEVENTH YEAR.
VOL. XIII. NO. 324.

NEW YORK, APRIL 19, 1889.

SINGLE COPIES, TEN CENTS.
\$3.50 PER YEAR, IN ADVANCE.

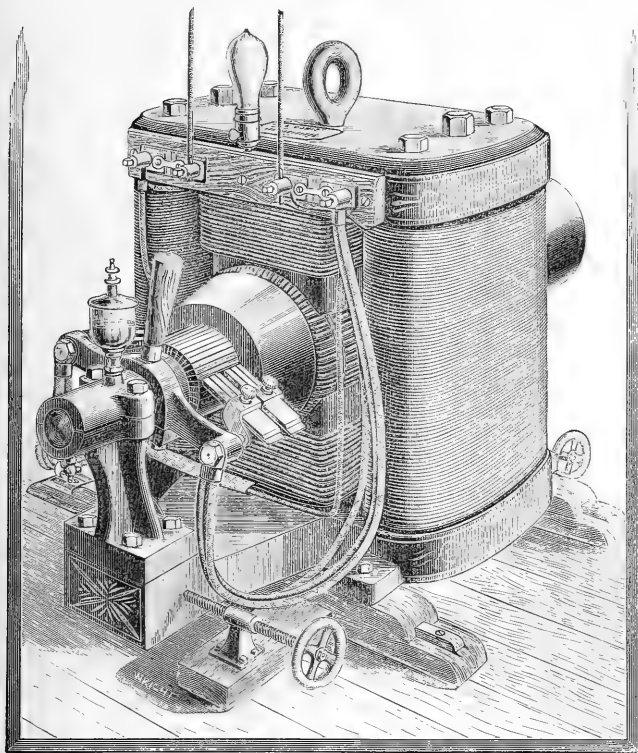

FIG. 1.



FIG. 2.

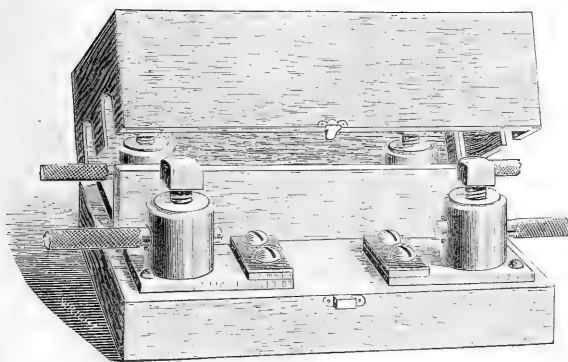

FIG. 3.

THE LOOMIS ELECTRIC-LIGHT SYSTEM.

Fig. 1. Dynamo; Fig. 2. Incandescent Lamp and Socket; Fig. 3. Fusible Cut-Out. [See p. 202.]

THE LOOMIS ELECTRIC-LIGHT SYSTEM.

THE Loomis system of electric lighting, though comparatively new, has been long enough in operation to test the value of the various features peculiar to it, and it has received the indorsement of many establishments in which it is in use. The field in which it

watch either the dynamo or a resistance-box. Moreover, no sparking at the brushes can be detected when the lights are turned on or off.

The self-regulation of the dynamo, which is not obtained by a waste of power in driving the current through resistance coils or in weakening the current by shifting the brushes from the point of

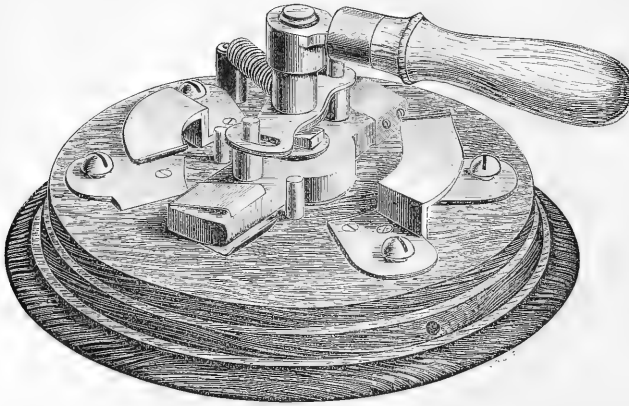

FIG. 4.—DOUBLE-POLE SWITCH.

is best known extends through the Eastern and Northern States, from Maine to Michigan.

One feature of the Loomis system is that the regulation of the dynamo is automatic; that is, that the dynamo "requires no more attention than a line of shafting." So long as the power is supplied and the bearings of the armature-shaft properly lubricated, the required amount of current is supplied, and no more, whether

greatest efficiency, enables the lamps to be kept up to their maximum of brilliancy at a minimum consumption of power, while it is believed that the steadiness of the current extends the life of the lamp to its utmost limit.

The main advantages claimed by this system may be summed up as follows: first, economy in cost of plant, owing to simplicity of construction of dynamos and accessories, and ease of installation; second, economy of maintenance, power being used only in proportion to the amount of light furnished, and no extra attendant being required; third, exemption from the necessity of stoppage for repairs, as it is maintained that the armature cannot be burned out under any circumstances; fourth, the light is steady; fifth, owing to absence of variation in the intensity of current, the lamp lasts longer than in systems where such conditions do not prevail.

The company maintains that the lamps are practically the only destructible parts of their system, and they guarantee them an average life of at least six hundred hours. They have on record one case in which 42 lamps in an installation of 123 are always lighted whenever the dynamo is in operation. Of these 42, 34 were still in use after 2,162 hours' service. Of this same installation, which is in a paper-mill at Holyoke, Mass., the treasurer of the paper company says, "I find I can cut out 122 of 123 lamps without increasing the brilliancy of the remaining one or causing any spark to form at the brushes."

The Loomis dynamo is shown in Fig. 1; the lamp and socket, in Fig. 2, the sockets being of such a design as to guard against liability to short-circuiting. Fig. 2 shows the actual size of a 16-candle-power lamp. Fig. 3 is a fusible cut-out. It has ample contact surfaces for the fuses, and consequently is not liable to give trouble by unnecessarily burning out. The switches, both double-pole and single-pole, have large contact surfaces, and make the break instantaneously. The double-pole switch is shown in Fig. 4. This company furnishes ammeters, voltmeters, ground detectors, and other electrical appliances and safety apparatus required for incandescent plants. The voltmeter is shown in Fig. 5. At an early date they will have ready a motor embodying the same general features as their dynamo.

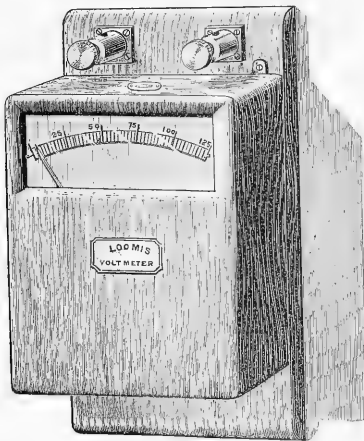

FIG. 5.—VOLT-METER.

there be only one lamp in circuit or the maximum number for which the machine is intended. The quantity of current is diminished as the lamps are extinguished, and increased as they are lighted, without any attention being paid to the dynamo, and it is claimed that power absorbed by the dynamo is in proportion to the number of lamps in actual use. The regulation of the dynamo so as to secure these results is accomplished by a simple method. There is no shifting of the brushes required, nor is any resistance introduced into the circuit, so there is no attendant required to

A CAVE of unexplored dimensions, containing a beautiful lake, the shores of which are covered with human bones and pieces of pottery, was discovered recently by two miners near El Paso, Tex.

AYRTON AND PERRY'S IMPROVED AND NEW
AMMETERS AND VOLTMETERS.

WE take pleasure in placing before our readers a description of the latest instruments of the well-known electricians, Professors Ayrton and Perry. Quite a full description of these remarkable

production of instruments without permanent magnets, they having found out by experience, that, no matter how well such magnets are aged, they will change in their strength, which makes them unfit for instruments which will be very accurate for any length of time. They discovered some years ago that a spring made of flat ribbon wound in corkscrew fashion will produce a very great rotary

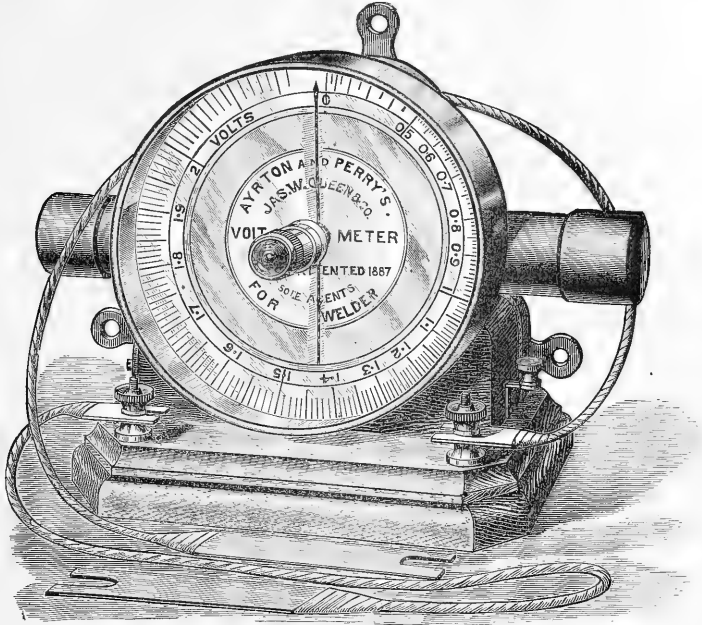

FIG. 1.—HOT-WIRE VOLTMETER.

instruments has just appeared in the London electrical journals, and has been copied in the American journals. We are, however, in a position to give some very important data recently received directly from Professors Ayrton and Perry, through their sole agents in the United States, Messrs. James W. Queen & Co., Philadelphia. This additional information not only covers great improvements

motion on one end free to move, while the other end is held in its place. This spring is used in all their new instruments, the permanent magnets having been discarded as early as 1883. Ayrton and Perry have perfected the methods of testing and calibrating their instruments, and we shall soon be able to give a full illustrated description of their laboratories.

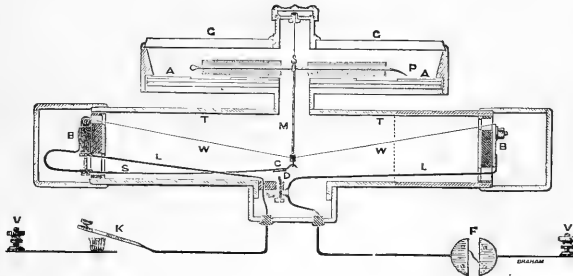

FIG. 2.—HORIZONTAL SECTION OF HOT-WIRE VOLTMETER.

which they have made in their well-known magnifying spring instruments, but also a full description of the hot-wire voltmeter, the first samples of which have just been received by J. W. Queen & Co. It is a well-known fact that the practical instruments which Ayrton and Perry have invented are now more largely used than any instrument upon the market. If we examine the work of these two eminent men in the line of testing-instruments, we will see that they have been largely devoting themselves of recent years to the

Very extensive experiments and investigations have furnished the necessary data to make these spring instruments the most accurate technical instruments in the market. It is very interesting indeed to follow Professor Ayrton's general reasoning, which gives a mathematical law to even the most minute things in reference to these instruments. Among his latest discoveries is that platinoïd wire is the best material to wind voltmeters to reduce the errors of temperature influence. In a very interesting description of the testing-

laboratory in which the ammeters and voltmeters are calibrated, we find some very important points about the D'Arsonval galvanometer. Numerous attempts have been made to use this form of galvanometer as direct-reading ammeters and voltmeters, but the employment of permanent magnets makes their instrument one of only a very limited degree of permanent accuracy. The same principle is employed by Sir William Thomson in his siphon recorder; and Messrs. Deprez and D'Arsonval, and many others, have tried to make commercial and portable instruments, as well as delicate laboratory instruments. All these instruments have the same defect, that their sensibility diminishes as the magnets grow weaker. Besides this serious trouble, further investigations have shown, that, in spite of the very small angles through which the coil moves, the deflections will not be proportional to the current. Ayrton describes this as follows: "If you start from the centre, so that the spot of light is at one extreme end of the scale for no current, you find, on carefully calibrating the instrument, that you get a broken line consisting of two straight lines meeting at an angle, or probably, strictly, meeting according to some curve at about the spot corresponding with the plane of the coil, being parallel to the lines of force. Hence there is a difficulty in dividing the scale uniformly; and this difficulty is met with even when the plan of using curved pole-pieces is adopted, as proposed by us some six years ago."

The most interesting instrument, however, brought out and perfected by Professors Ayrton and Perry, is the new direct-reading hot-wire volt- and ammeter. The underlying principle is that which is used by Cardew in his voltmeters, — that the passage of a current will heat a wire, and thereby lengthen it. Ayrton and Perry had an excellent means in their patent springs of multiplying the minute changes of the dimensions; and the employment of this very spring reduces the Cardew of three feet length and four yards of fine wire to one in which eight inches of wire are sufficient to indicate differences of potential of less than $\frac{1}{100}$ of a volt. The above figure shows a cross-section of the instrument as at present constructed. The combined pull of the spring *M* and of the platinum-silver wire *WW*, attached to the blocks *B*, *B*, is counterbalanced by the pull of the spring *S*. Hence, as the wire stretches, the magnifying spring *M* is stretched, and the point *P*, to which a number of fine hairs are attached to introduce damping without solid friction, rotates. The flat spring is not only introduced to enable the depth of the instrument to be diminished by twice the sag of the wire, but to enable a particular arrangement of fuse to be employed.

The fuse *F* is of such a diameter that it would require a far larger current to melt it than would damage the instrument. In addition, a platinum-tipped screw, *D*, is arranged so that when the wire *WW* stretches by any pre-arranged percentage beyond the amount it stretches for the maximum safe potential difference, the platinum tip *C*, of the flat spring *S*, comes into contact with the screw *D*, and the working wire is short-circuited. The circuit is then temporarily completed through the lead *L*, to the left of the flat spring *S*, and the fuse *F*, when the current increases and the fuse melts without damage to the instrument. With this device, they find that the fuse may be thick, and therefore have but a small resistance compared with that of the working wire, and yet the sudden application of a potential difference five or six times as great as the maximum potential difference the voltmeter is intended to measure, melts the fuse without damaging the working wires. For clearness, the fuse, the key, and the terminals *V*, *V*, are shown detached from the instrument, but they are in reality in the base, as seen in Fig. 1.

AN ELECTRIC DOOR-OPENER.

An improved electric door-opener, manufactured by Wendt & Co., of this city, is shown in the accompanying illustration. It requires but small battery power. The wires are concealed from view; and a slight pressure on the ordinary electrical push-button not only releases the latch, but causes the door to be thrown open. The closing of the door resets the opener automatically.

The mechanism of the door-opener is simple. *B* is a throw-back, which swings on a pivot to which is attached the inner end of a

coiled flat spring. To a crank on the end of the pivot, outside the coiled spring, is attached a spiral spring. The closing of the door swings the throw-back around on its pivot, thereby compressing the coiled spring, which is of sufficient strength to force open a heavy door when released. The spring is prevented from acting until the armature, which is pivoted at the lower right-hand corner of the opener, is attracted by the electro-magnet. The movement of the armature allows free movement to a tongue pivoted to the up-

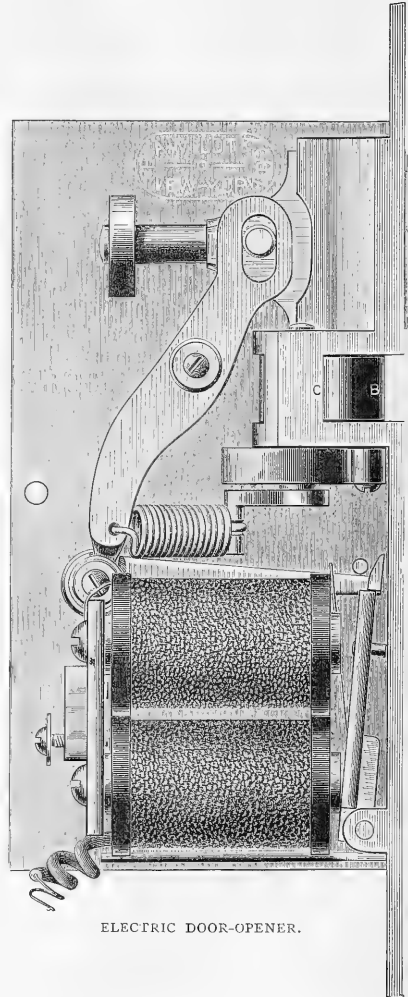

per left-hand corner of the electro-magnet, against which the latch-bolt lever bears. The action of the opener is as follows: When the circuit is closed by a touch on the button, the armature is attracted by the electro-magnet; the tongue moves, thereby releasing the spiral spring, which pulls back the latch-bolt; and at the same time the coiled spring forces the door open by means of the throw-back.

THOMAS WHITTAKER has just published "The Washington Centennial Souvenir," — a large, finely printed, and handsomely illustrated brochure arranged by Frederick Saunders of the Astor Library.

BUILDING-STONES OF EAST TEXAS.

It is generally supposed that building-stones are very rare in eastern Texas, and that nothing harder than a clay or sand bed is to be found. This is far from true, according to R. A. Penrose, jun., in the Texas *Geological and Scientific Bulletin* for March, as there are found in many of the eastern counties rocks which combine variety and beauty with strength and durability. The sandstones are the most important; the limestones, though equally serviceable, being less widely distributed.

The State Penitentiary, at Rusk, is built of a yellow sandstone composed of grains of silicious sand and altered greensand. It is of a yellow color, easily cut, and occurs near the penitentiary in a bed about twelve feet thick. This Claiborne greensand itself is also used extensively for building chimneys and foundations, and in many cases it might be used for more extensive structures. It is found in many places in the form of a yellow indurated mass, the color being due to the alteration of the greensand. It is also found of a green color and a compact clayey consistency. Both these varieties are found in many places of sufficient strength to prove of considerable value in building, though they are generally soft and crumbly.

Near Alto, in Cherokee County, and elsewhere, is found a white sandstone, very tough, hard, compact, and durable. It is in some places slightly colored by oxide of iron, but in others is of a pure snow-white. It occurs in a bed capping the Claiborne marls, and varies from one to three feet in thickness. This would prove a most serviceable rock for building-purposes; and where it preserves its white color, without blotches from iron, it is by far the most beautiful rock in eastern Texas. It has as yet been but little used, but, with the rapid start in the development of its resources that eastern Texas is taking, it is bound to find the place it deserves among the stones of the State. A variety of it from five miles west of Jacksonville is said to have been used with great success for mill-stones. It is also found in other places.

Brown sandstones of variable composition and hardness are found in many places, and are the most generally distributed, and consequently most important of the East Texas building-stones. They occur in many localities, and vary from a light brown, soft and easily cut rock, to a hard flinty variety of a dark-brown color. The beds are from one to over fifteen feet thick, lie horizontally, and are usually found capping knolls or hills. They are sometimes the result of induration by the agency of oxide of iron, of quaternary sands, and at others the result of a similar change in eocene sands. The source of the iron solutions which caused this cementing action has been the oxidation of pyrites in the bed, or of ferruginous solutions percolating through the bed and derived from the decomposed pyrites in associated beds, such as pyritiferous lignites, greensands, and clays.

The limestone of Scott's quarry, in Smith County, is a hard, tough, compact gray rock, excellently adapted for building-purposes, and of great durability.

TEXAS ASPHALTUM.

THE absolute need of material suited for serviceable pavements is well known and fully appreciated all over the State of Texas. In some of the principal cities there have been considerable bodies of pavements laid with asphaltum brought from Trinidad, by mixing it with a certain amount of calcareous matter, and heating it to such a point that it would harden on cooling. This is done to imitate the natural mixture of limestone and bitumen found in the deposit of Val-de-Travers, of which the best French pavements are made. Dr. Ure, speaking of these two materials, says: "Bitumen alone is not so well adapted for making a substantial mastic as the native compound of bitumen and calcareous earth, which has been properly called asphaltic rock, of which the richest and most extensive mine is that of Val-de-Travers. The calcareous matter is so intimately combined and penetrated with the bitumen as to resist the action of air and water for any length of time. It would indeed be a difficult matter to combine, by artificial methods, calcareous earth thus intimately with bitumen; and for this reason the

astics made in this way are found to be much more perishable." In these deductions he is fully borne out by the experience of those using the two materials throughout Europe, and even in this country.

Among the specimens collected by Col. J. L. Tait, on his trip to South-west Texas last November, was a small piece of a dark-blue limestone thoroughly impregnated with bitumen. The rains were so continuous, however, that no detailed examination could be made, but later it was found that the quantity is equal to all demands; and a somewhat larger specimen was obtained and subjected to analysis, with the result of proving it almost identical in composition with that of the Val-de-Travers, as will be seen by the following:—Val-de-Travers: bitumen, 20 per cent; limestone, 80 per cent. Uvalde County: bitumen, 20.35 per cent; limestone, 79.65 per cent.

This, E. T. Dumble, in a communication to the Texas *Geological and Scientific Bulletin*, thinks will prove to be of great and lasting benefit to the State. In addition to this, many deposits of bituminous sands or shales occur which yield ten per cent, and sometimes a larger amount, of bitumen.

EXPLORATION IN MEXICO.

IN the winter of 1887-88, Dr. Ed. Seler undertook a journey to Mexico to pursue archaeological researches. A preliminary report of his expedition is given in the "Proceedings of the Royal Geographical Society," from which we learn that he devoted himself principally to researches in the country of the Huasteca and Zapoteca. The important result of his journey is the demonstration of the fact that the apparent and supposed fundamental difference between the Aztec hieroglyphics and the Maya manuscripts does not exist. Dr. Seler, starting from the capital, first visited the Huasteca Indians. Their territory is an extensive forest country. The fertile mountain slopes and river lowlands are everywhere clothed with luxuriant tropical forest, in which fig-trees, and, as underwood, bamboos, are conspicuous. The open valleys and the high ridges which extend between the river-courses are covered with either thin or thick forests of fan-palms. In the clearings, tall, many-colored grasses and mimosa-bushes cover the ground.

The principal villages are situated along the river-courses and upon the plateaus between the rivers. Numerous small ranches are scattered through the woods. The inhabitants are principally engaged in cattle-raising; horses, oxen, and mules living out in the forest, and being driven into the corrals only once a year. The capital draws its chief supply of meat from this province, the cattle being driven to Pachura, whence they are conveyed by rail to the city. Agriculture is carried on only to a very limited extent; and it is a significant fact that this country, which might supply half of the whole republic of Mexico with corn, imports this very article from the United States. There are no irrigation-works, by means of which the destructive effects of droughts might easily be obviated. The Indians grow corn, black beans, and pepper, and make brown sugar and smoked bananas. They manufacture mats from palm-leaves and agave fibre. Candles are made from the plentiful supply of tallow obtained from the cattle. The principal imports are coarse calicoes, ribbons, beads, cheap articles of finery, harnesses, hardware, liquor, and petroleum. There are only very few people who can read and write. Their amusements consist in fandango-like dances, cock-fighting, and horse-racing.

The roads are mere trails cut through the forests, which, in bottom-lands and at river-crossings, are often exceedingly difficult, and impassable to all but native horses. The customary house in the country is the *jacal*, or thatched house (from the Aztec *xacalli*), the walls of which are constructed of bamboo sticks tied together with *Ficus angelica*; while the roof is made of the leaves of the fan-palm neatly plaited, and is absolutely water-tight. In the larger villages there are also houses built of white bricks.

The principal articles of food are black beans, coffee, and cakes of ground corn without salt,—the so-called *tortillas*, which are always eaten hot and fresh. There are no inns, and the traveller has to rely on hospitality.

The antiquities of the country do not consist of such great pyramids as those of Xochicalco, or the palace of Palenque, but they possess a peculiar style of their own, and afford important material for reconstructing the ancient history of Mexico. They are difficult to find, for since the days of Cortes the primeval forest has completely covered and buried them. The houses of the ancient inhabitants stood upon raised foundations, consisting of small pyramids of regularly hewn stones. Among these heaps of stones the largest trees of the virgin forest have expanded, and separated the stones from one another. During the construction of railways, a large number of these pyramids were opened; and in this way a quantity of household furniture has been found, especially painted pottery, and statuettes of beautiful forms, and made of excellent material. The tropical rains also bring to light many objects of the same kind.

Dr. Selser then visited the territory of the Zapotecas, in the state of Oaxaca. The condition of this region is considerably more advanced than that of the country of the Huasteca. The land is richer and better cultivated, the villages better built. Intellectually it is the most advanced state of the republic. The numerous valleys which cut into the high lands, and the numerous rivers which have to be crossed, present special difficulties to the development of trade and commerce. In many cases the river-bed itself forms the road; and in the rainy season, from August to October, intercourse is often interrupted for months at a time.

The territory of the Zapotecas is the land of mounds and bastions. These have partly served as fortifications, partly as tombs, many of which remain to be opened, for the law which prohibits the exportation of antiquities is only too well calculated to discourage explorers. Here Dr. Selser discovered numerous inscriptions and important paintings which had escaped the notice of former observers. The hieroglyphics discovered on the national sanctuaries of the Zapotecas may, should they be completely deciphered, afford a key to the proper understanding of the connection between the Maya and Aztec civilizations.

HEALTH MATTERS.

Baking-Powders.

PROFESSOR J. W. MALLETT of the University of Virginia has recently made a series of experiments with alum baking-powders, and studied effects upon digestion of the residues left therefrom in bread. A full report has been published in the *Chemical News*. He says that it has been almost universally conceded that alum itself, when added singly to bread or other food, is positively injurious to health; and that its use, even in the small proportion sometimes employed to improve the appearance of bread made from unsound or inferior flour, must be regarded as reprehensible. But since the extensive introduction, in the United States, of baking-powders made with alum and bicarbonate of soda, there has been much dispute as to the harmlessness or harmfulness of the substances which are left in bread made with such powders after the mutual re-action of their constituents and the completion of the baking process.

It has been claimed, by those who advocate the use of cheap baking-powders made with alum as one of the ingredients, that as soon as the mixture of alum (usually first deprived, by heating, of the whole or much the greater part of its water of crystallization, — so-called "burnt alum") and bicarbonate of soda is moistened, as in working it up with flour to form dough, the aluminum sulphate is decomposed, sodium sulphate being formed, with which there also remains sulphate of ammonium or potassium, as ammonia or potash alum has been used; and the aluminum assumes the form of aluminum hydroxide, insoluble in water, and therefore supposed to be inert and harmless in the stomach and alimentary canal. It has been noticed that the aluminum is also partly converted into phosphate in presence of the phosphates naturally occurring in flour, and this has been also taken to be insoluble and inert. It has been further claimed, that, at the temperature of the baking-oven, aluminum hydroxide is itself decomposed, water being given off, and the highly insoluble aluminum oxide, or alumina, left behind, to be discharged from the intestines as might be so much clay or other harmless and indifferent matter.

On the other hand, it has been asserted, by some of those who oppose the use of alum in baking-powders, that the decomposition is not, or may not be, complete, and in any case, that, as all of the constituents of the alum remain in the bread, the action upon the human system must be essentially the same as if the alum itself remained intact.

In the discussion of the effects on health of the residual substances left in bread made with alum baking-powders, there has been a good deal of loose argument, based upon data which were either merely assumed as probable, or were too imperfectly supported by actual experiment. In such experiments as have been hitherto recorded, bearing directly on the question, there are many points left in an indeterminate state, and calling for further investigation in order to clear them up and admit of an impartial conclusion being reached. The work undertaken by Professor Mallett was with a view to furnish some more exact and satisfactory evidence of the kind required for the purpose of reaching such a conclusion.

In the examination, twenty-seven samples, representing seventeen brands, were analyzed. Nearly all contained as their acid ingredient a mixture of alum and acid phosphate of calcium ("superphosphate"). All contained as the alkaline ingredient acid carbonate of sodium ("bicarbonate of soda"). After a most thorough and painstaking inquiry into the whole subject, he reached the following conclusions: 1. The greater part of the alum baking-powders in the American market are made with alum, the acid phosphate of calcium, bicarbonate of sodium, and starch; 2. These powders, as found in retail trade, give off very different proportions of carbonic-acid gas, and therefore require to be used in different proportion with the same quantity of flour, some of the inferior powders in largely increased amount to produce the requisite porosity in bread; 3. In these powders there is generally present an excess of the alkaline ingredient, but this excess varies in amount, and there is sometimes found, on the contrary, an excess of acid material; 4. On moistening with water, these powders, even when containing an excess of alkaline material, yield small quantities of aluminum and calcium in a soluble condition; 5. As a consequence of the common employment of calcium acid phosphate along with alum in the manufacture of baking-powders, these, after use in bread-making, leave, at any rate, most of their aluminum in the form of phosphate (when alum alone is used, the phosphate is replaced by hydroxide); 6. The temperature to which the interior of bread is exposed in baking does not exceed 212° F.; 7. At the temperature of 212° F., neither the "water of combination" of aluminum hydroxide, nor the whole of the associated water of either this or the phosphate, is removed in baking bread containing these substances as residues from baking-powder; 8. In doses not very greatly exceeding such quantities as may be derived from bread as commonly used, aluminum hydroxide and phosphate produce, or produced in experiments upon himself, an inhibitory effect upon gastric digestion; 9. This effect is probably a consequence of the fact that a part of the aluminum unites with the acid of the gastric juice, and is taken up into solution, while at the same time the remainder of the aluminum hydroxide or phosphate throws down in insoluble form the organic substance constituting the peptic ferment; 10. Partial precipitation in insoluble form, of some of the organic matter of food, may probably also be brought about by the presence of the aluminum compounds in question; 11. From the general nature of the results obtained, the conclusion may fairly be deduced, that not only alum itself, but the residues which its use in baking-powder leaves in bread, cannot be viewed as harmless, but must be ranked as objectionable, and should be avoided when the object aimed at is the production of wholesome bread.

QUARANTINE CONFERENCE. — The recent quarantine conference which convened at Montgomery, Ala., discussed most thoroughly the question of yellow-fever in all its aspects. As it was composed of the most experienced sanitarians of the country, many of whom have been repeatedly engaged in fighting yellow-fever epidemics, the conclusions of their deliberations are entitled to great respect and consideration. The method of disinfection as practised at the New Orleans station, by the use of superheated steam in steel cylinders under pressure, was indorsed as being the best

method known to science. The surgeon-general of the Marine Hospital service (who was present) was requested and promised to erect at Tampa, Fla., a similar plant. The administration of marine quarantine, as now carried out by the surgeon-general, was especially commended, and the request was made that more stations and more men be devoted by him to this work. The co-operation of the management of the Plant Line of steamers, plying between Havana and Tampa, with Dr. Burgess, United States medical inspector at Havana, was commended as an example for cleanliness of ships, scrutiny of passengers, and disinfection of baggage. By special resolution, the attention of the secretary of the treasury of the United States was called to the prevalence of smuggling between Cuba and the Florida coast, and the great danger of introduction of yellow-fever by this illicit traffic; and he was requested to use additional precautions, and, if possible, put a stop to it. On the question of inland quarantine it was decided, that, as far as possible, this should always be declared, where they exist, by State boards of health; and that by whomsoever declared, within thirty-six hours after the proclamation, comfortable quarters, with provisions and bedding, must be provided for the unfortunates detained at the station. The conference, by a decided vote, refused to indorse the proposition that it was necessary to disinfect a town or city in which yellow-fever had prevailed, but in which there had been no cases for several months, and the place had been subjected to the frosts and freezes of winter; deeming that the use of disinfectants under these circumstances was not only useless, but tended to breed unnecessary terror and distrust not only among the people of the place, but of surrounding States.

TREATMENT OF OBESITY. — Dr. W. T. Smith communicates to the *British Medical Journal* a method for the treatment of obesity which he has successfully employed in forty-three cases, including himself. The plan which he follows is to confine the diet to rump-steak, cod-fish, and hot water for fourteen days, with the absolute exclusion of every thing else. Taking meat in large quantities may lead to dyspepsia, but this can be easily overcome by reducing the meat to an essence. This may be done as follows: Take four pounds of beef free from skin and fat; cut it to pieces about an inch square; place the meat in a close-fitting, air-tight jar; stand the jar in a pan of boiling water, and let it simmer for six hours. Pass the juice of the meat thus obtained through a sieve; then measure four ounces of the fibrine of the meat; pulverize it in a mortar, and stir it up with the essence; divide this into four doses, and you will obtain the nitrogenous elements required of the quantity of meat to be taken at one meal. There is also a similar way of obtaining meat-essence by using a pot called "Boule Américaine." In treating his cases, in several instances he has been obliged to modify the amount of hot water, and lessen occasionally the quantity of meat; but as regards his own personal experience, he found that three pounds of rump-steak and one pound of cod-fish were hardly sufficient to satisfy his appetite. The meat diet and hot water alone must be regularly adhered to for fourteen days; and the amount of hot water taken at any time during the day, commencing at seven in the morning and finishing at half-past ten at night, varies from six and one-third pints, more or less, according to the powers of the patient. The second epoch of twenty-one days the diet may be considerably varied, as he reduces the hot water to four pints in the twenty-four hours; and he allows other kinds of meat, such as mutton-chops free from fat, and chicken; and, as regards fish, grilled turbot, whiting, or soles; a little green vegetable, and some slices of plain unsweetened rusk. The third epoch, thirty-one days, the hot water is reduced to about a quart a day, and he allows tea, stale bottom crust of household loaf, captain's biscuits, grilled fish, fowl, game, turkey, any joint, hock or claret, with seltzer-water, in place of whiskey. As hot water is very unpalatable, a slice of lemon may be added to each tumbler. No case of obesity should be treated by this method when the patient is suffering from any organic disease, unless it be some trifling malady. The loss of weight in nearly all cases will vary somewhat; but Dr. Smith states that his patients bear the treatment exceedingly well, and express themselves as feeling far better in health, and able to take exercise with comfort. The first period of fourteen days is really the only hardship, and he has found very little difficulty in persuading patients to stick to the

diet. As some alkali is essential, he prescribes five grains of the bicarbonate of potassium, to be taken night and morning. Dr. Smith offers to send his diet-cards to any medical practitioner who will write to him, but asking that the result of any case put under treatment be reported to him.

ELECTRICAL NEWS.

The Clark Cell as a Source of Standard Currents.

FOR measuring small currents, there are two methods which should give good results. The first is by the use of an electro-dynamometer, where the mutual actions of circuits carrying the current are balanced by known weights. In this instrument the changes in the magnetic field do not affect the results; and but for its inconvenience, and the fact that continuous readings are impossible, electro-dynamometers would be universally used. In the second method an ordinary galvanometer of any convenient pattern could be employed, provided it could be easily calibrated in order to eliminate errors due to changes in the earth's field or to the field due to magnets on the instrument itself. In order to effect this calibration, Messrs. Threlfall and Pollock have endeavored to obtain a galvanic cell whose electro-motive force will remain constant; and, by sending a current from this through a known resistance, the value of the current is known, and it can be used to standardize a galvanometer meter. In the form of instrument chosen, a movable coil was employed, with an adjustable directing magnet. To calibrate it, the coil was moved to a marked position, a current from the standard cell was sent through it, and the directing magnet moved up or down until the deflection reached a certain set value. This can be easily and rapidly done.

The standard cell was of the Clark type, now almost universally used for comparisons of electro-motive force. From the ordinary type, only an extremely small current can be taken, or the electro-motive force will drop and the cell be ruined. In the type devised by Messrs. Threlfall and Pollock, a much larger surface than ordinarily used was employed. In a paper read before the London Physical Society the gentlemen named give the result of a long series of experiments on these cells. The conclusions at which they arrive are as follows:—

1. When a current is taken from a Clark cell, the terminal electro-motive force drops practically instantaneously to within an inappreciable amount of its final value.
2. To the first degree of approximation, this value is constant.
3. There is no appreciable secular change.
4. When the current is stopped, the terminal electro-motive force rises instantly to within a few thousandths of a volt of the original value.
5. The cell completely recovers in time.
6. The above statements are only true when the current does not exceed a certain value, depending on the size of the cell. For a cell in which the zinc and mercury surfaces have each a value of five inches or upward, .007 of an ampère will not be too great; for the ordinary cell used as a standard of electro-motive force, the current should not exceed one hundredth of this value.
7. When too large a current is taken from any cell, the electro-motive force goes on dropping for some time, after which it rises slightly, and seems to tend toward a fixed value.

THE DETROIT SECONDARY BATTERY. — One of the new secondary batteries which has been attracting considerable attention during the past few months is the Detroit battery, manufactured by the Woodward Electric Company of Detroit, Mich. It is of the Faure type, with a support-plate of lead and active material consisting of salts of lead in cavities in the support. The method of making the support-plate is decidedly novel. Rock salt is put into a square mould, and is baked. Melted lead is then run into the mould and allowed to solidify. The cube thus formed is sawed into plates, and the salt is dissolved out of them by putting in warm water. The result is a plate full of cavities of irregular shapes, having in general an overlapping portion, which prevents the active material from falling out. A solid rim with a lug for a terminal is cast around this central porous portion, and then red lead or litharge is pasted into the cavities. The plates are then put in a cell containing sulphuric acid, and formed by sending a current of electricity from the positive to the negative set. The Detroit batteries have

been pretty extensively employed for lighting, and lately experiments have been made with a view to their adoption for street-car work. A car in Brooklyn equipped with these cells has made over eighty miles with one charge,—a record which has not been equalled; although the distance a car can go does not determine the value of the battery used, since the very important question of weight should enter, and in this case the weight is over five thousand pounds. The Detroit cells have been recently tested at the Johns Hopkins University, and a few figures as to their performance will be of interest. Taking a cell with 15 plates, of which the total weight is 80 pounds, the following results were obtained: charge rate, 15 ampères; discharge rate, 20 ampères; storage capacity, about 220 ampère hours; efficiency, between 75 and 80 per cent. This cell, after experiments at normal charge and discharge rates had been made, was charged at a rate of from 75 to 85 ampères, and discharged at over 250 ampères; and this was done a number of times. At the end of the tests there were no signs of deterioration, which, considering the rough usage to which the cell had been subjected, speaks well for their durability, although the length of the experiments was not sufficient to test their length of life under normal conditions.

THE MAGNETIC PROPERTIES OF NICKEL.—Professor Ewing, whose researches on the magnetic properties of iron are so well known, has examined the magnetization of nickel under various conditions. He finds that nickel behaves very much as iron does when submitted to a magnetizing force. The permeability, or magnetic conductivity, is small at first, then increases to a maximum, then decreases again. The maximum value of the induction obtained was 5,380, so that nickel is about one-quarter as magnetic as iron. When a piece of nickel was heated to redness and then allowed to cool slowly in the air, its permeability increased. On stretching a piece of nickel, its permeability decreased rapidly. For example: a certain specimen of wire had a value of the maximum magnetic susceptibility for no load, of 15. With a load of 13 pounds, this was reduced to 2.6, while at 26 pounds it was but .95. On submitting specimens to compression, the reverse effect was found: as the pressure increased, the magnetic susceptibility increased from 5.6 at no load, to 29.0 at a load of 45 pounds per square millimeter.

A CHALLENGE TO THE WESTINGHOUSE COMPANY.—Mr. Harold P. Brown has issued a challenge to the Westinghouse Electric Lighting Company, to a competitive test of the apparatus of that company against a corresponding continuous-current plant. Each company is to provide a plant capable of furnishing 650 lights. These are to be sent to the Testing Bureau of the Johns Hopkins University, where they are to be tested for efficiency. The loser is to purchase the winning plant, which is to be presented to the university; and he is also to pay all of the expenses of the test. If the Westinghouse Company desires it, they may use one of the Westinghouse engines, while Mr. Brown will employ for the continuous-current plant some other make of automatic high-speed engine. If the Westinghouse Company does not accept the challenge, Mr. Brown will consider himself at liberty to purchase an alternating plant and have the test made. It is to be hoped that the test will be made, as systematic knowledge of the performance of alternating apparatus is wanting, although the marked success of the system speaks well for its efficiency.

THE CONDUCTIVITY OF MICA AT HIGH TEMPERATURES.—W. H. Schultze, in *Wiedemann's Annalen*, describes a number of experiments on the conductivity of mica at high temperatures. It is well known that the conductivity of glass increases rapidly with the temperature, a fact which in many cases is a serious inconvenience. The results of Mr. Schultze's experiments are, that while mica split parallel to the planes of cleavage shares with glass the property of becoming a better conductor as the temperature rises, yet the conductivity reaches a maximum, and after that diminishes until at very high temperatures it becomes infinitely small; so that, comparing glass and mica, it is seen that even at high temperatures the latter is the better insulator.

A. J. DREXEL, the banker, is about to found an industrial college for women at Wayne, Penn., at a cost of \$1,500,000.

NOTES AND NEWS.

SOME interesting experiments were made March 22 near Dartford with the Maxim Nordenfellt quick-firing and automatic guns. As described in *Engineering*, the first weapon fired was the Maxim automatic gun of .45 caliber, and with this 334 rounds were fired in twenty-seven seconds. A comparative test was then made between ordinary rifle-powder and the new Maxim smokeless powder. A cartridge containing 85 grains of black powder, and others containing 55 grains of the new powder, were fired. The last-mentioned cartridges gave a slightly greater velocity, and at the same time produced extremely little smoke. Among the other guns tried was an automatic six-pounder, which has a dropping block like the Sharpe's rifle. It requires only two men to work it, one man firing and the other loading. Every thing about the gun is fixed save the gun itself, which is placed inside a jacket, which latter is also fixed. There can be no danger of escape of gas or from a hang-fire. The gun, on being fired, recoils about $4\frac{1}{2}$ inches, and then returns to its original position. The cartridge-case is not ejected till the gun has travelled some little distance on its return journey. The act of putting in the new cartridge pushes forward the ejectors and releases the block, which rises and closes the breach. If great rapidity is required, one man on a saddle with a butt to his shoulder aims and fires, while a man on each side puts in the cartridges. If only one gunner is left unskilled, a single man can work the gun in the following manner: having laid the gun and fixed the trigger in a firing position by a bit of wood or string, he simply puts in cartridge after cartridge, the gun on each occasion going off as the cartridge is pushed forward. It can be fired, with two men to load, sixty times a minute.

—The kaolin and pottery clays of Texas are beginning to attract considerable attention. There have been representatives of several of the different Northern and Western potteries through the State during the last few weeks, looking up the ordinary pottery clays as well as the kaolin of Edwards and adjoining counties. The deposits of these materials are abundant, and of such quality that they are certain to be brought into market at an early day.

—An English correspondent of the *American Field* writes that a new gunpowder, the invention of Mr. Hengst, has recently been tested at the Royal Gunpowder Factory, Waltham Abbey, England, and the results point to it as a promising substitute for black powder for military and sporting purposes. The new powder is prepared from straw, which is pulverized, chemically treated, and finished in granular form for use. It is claimed for this powder that it is smokeless, flameless, practically non-fouling and non-heating, and that both the recoil and the report are less than those of black powder, with superior penetrative power. From the powerful character of this explosive, which, weight for weight, is 150 per cent stronger than gunpowder, and is not explodable by concussion, it is probable that in a compressed form it will be found to be applicable to blasting-purposes.

—President Patton says that after June 1 the Princeton College will have added to its permanent endowment fund \$250,000 through the kindness of many old and some new friends.

—Mrs. Eliza A. Clark of Cleveland has given \$100,000 to the Cleveland College for Women, a department of the Western Reserve University. One-half the amount is to be expended in erecting the Clark Hall of Liberal Arts.

—The committee on science and art, of the Franklin Institute, has recommended the following awards: of the John Scott legacy medal and premium, to Thomas A. Edison of Orange, N.J., for his invention of the mimeograph, an improved duplicating system and apparatus; of the Elliott Cresson medal, to Edward Alfred Cowper of London, England, and J. Hart Robertson of New York, for their invention of a system of facsimile telegraphy, called "The Writing Telegraph;" of the John Scott legacy medal and premium, to A. A. Marks of New York, for his improvements in artificial limbs; of the John Scott legacy medal and premium, to Thomas Shaw of Philadelphia, for his mine-inspector's gas-testing apparatus; and of the John Scott legacy medal and premium, to Roman

Abt of Luzerne, Switzerland, for his system of railways for steep inclines.

— "According to a careful estimate," says the London *Iron*, "the number of war-vessels launched last year by the naval powers of the world was 60, while more than 100 were building when it closed. England led with 15 vessels launched, and 28 building; France launched 9, and laid down 15; Russia launched 2, and began 10; Germany put 6 vessels into the water, and ordered or laid down 4; Italy launched 10, and laid down 18; Austria launched no vessel, but laid down or ordered 3; Sweden laid down 1; Denmark launched 1, and laid down another; China added 4 vessels to her navy, and ordered or laid down 4 more; Japan ordered 3, and launched 3; the United States launched 6, and laid down 6; Chili ordered a new cruiser in England, and the Argentine Republic contracted for a 4,300-ton ironclad; Brazil laid down a cruiser; and even Uruguay has contributed to the navies of the world, launching a small iron gunboat. The minor powers, like Greece and Portugal, have either contracted for or launched small vessels. Turkey has begun the work of building up her navy, laying down one ironclad and several smaller vessels."

— An article published in the Oil City *Derrick* recently, contains some statements regarding the area and character of the illuminating oil-bearing territory, which *Bradstreet's* believes should be re-assuring to believers in a possible future oil-famine in this country. The oil regions as now developed, the article states, "extend from Wellsville, N.Y., crossing Pennsylvania at nearly a 45-degree line to Dunkard Creek, in West Virginia. On an air line, this covers a distance of 204 miles in length; and, so far as developed, the belt is about 10 miles in width. The yield of the oil-fields up to March 1, 1889, was 340,133,997 barrels. About 150,000,000 barrels of this came from McKean County alone, and this county is still good for 20,000 barrels a day." The total future production of this belt is beyond prediction. It has been noted, says the article, that oil-bearing rock, wherever found, usually yields about the same quantity of oil to a given acre. The yield of oil per square mile of territory during the first fifteen years of its existence is about 1,000,000 barrels. It is considered certain, however, that each of the 204 square miles of territory will not yield this quantity. If it did, the total production there outlined would be about 2,040,000,000 barrels. "This belt of 204 miles is a chain of pools, large and small; and, until the area of each one is known, the total yield would be simply conjecture." The figures and estimates given relate only to the region where the illuminating-oil of commerce is produced; namely, New York, Pennsylvania, and the Macksburg district in Ohio. The great Lima field is not taken into account, nor Colorado, California, Kentucky, or Tennessee. "It has been stated that under the energy of the drill, the Ohio field might be made to yield 100,000 barrels a day. This is not improbable, since the Bradford field in July, 1882, produced 105,102 barrels each day of that month. The Bradford field had no large wells, compared with the geysers of Ohio. Lima oil is worth but about one-seventh as much as the Pennsylvania product, and can never come into competition with it as an illuminant, unless some new process of manufacture is discovered beyond any thing now known. Its utility in the world's economy lies in the direction of fuel, and there is not much likelihood that it will ever be diverted from this field. Natural gas is the only fuel that can compete with it in cheapness, and that is not everywhere obtainable. Natural gas cannot be transported much above 100 miles, and oil-fuel may be carried to the ends of the earth. As far west as Omaha it is now furnishing manufacturers a cheaper fuel than coal." With the above large supplies of oil, both for illuminating purposes and for fuel, in sight, the writer of the article apparently sees little reason to fear an oil-famine, as he states it, as among the immediate probabilities.

— John Ericsson desired that if any biography of him was undertaken, it should be intrusted to his friend, Col. William C. Church, editor of the *Army and Navy Journal*, and the executors of the estate accordingly have turned over to Col. Church all the papers which could be useful in such a work. While it is true that Capt. Ericsson destroyed his diary, and his documents since 1860 were preserved. In private letters and other papers has been

found abundant material relative to his youth and the influences which shaped his early career. Col. Church will contribute some valuable papers embodying much of this material to the fall numbers of *Scribner's Magazine*, which have been prepared by the help of these original documents. They will afterwards be expanded into an adequate biography.

— Another of Dr. Andrew D. White's papers on "The Warfare of Science" will be among the contents of the *May Popular Science Monthly*. This article is devoted to diabolism and hysteria, and will contain accounts of the dancing and other manias of several centuries ago in Europe, and the witchcraft delusion in this country, for which many innocent persons met their death, showing that these epidemics originated in nervous derangements, and were magnified and distorted by false theories. An extended reply to Professor Huxley's article on "Agnosticism," which was published in the last number of the monthly, will appear in the May issue. This view of the other side of the subject is given by Rev. Dr. Henry Wace, principal of King's College, and the Bishop of Peterborough, whose earlier utterances had been criticised by Professor Huxley. Every one who has wondered how the marvellous artistic effects of our best mosaic windows are produced will be interested in the account of a visit to a colored-window studio, which Professor C. H. Henderson will contribute. The article is entitled "The History of a Picture Window," and contains illustrations of the several processes of manufacture. Finally, "The Strange Markings on Mars" is the title of an illustrated article. The author, Mr. Garrett P. Serviss, tells how these markings have been explained, and shows the bearing of what is known about this planet upon the question whether or not it is the abode of life.

— The *Contemporary Review* for April (New York, Leonard Scott Publication Company, 29 Park Row) opens with two timely papers on the political situation in France, by G. Monod and P. G. Hamerton; Professor A. V. Dicey discusses the rights of public meetings, viewing the matter from the standpoint of a lawyer, and not as a politician; the Rev. Horace Waller treats of the slave question in Africa in an article entitled "The Two Ends of the Slave-Stick;" Professor Edward A. Freeman contributes a lengthy paper on Christianity and the "geocentric" system; Dr. Dale continues his interesting papers on Australia, devoting himself this month to a consideration of religion and morals; Dean Plumtree writes an interesting and novel paper on Shakspeare's travels in Somerset, Wales, and the Netherlands, basing his argument on extracts from the plays and poems; James Runciman writes on the ethics of the turf; and Professor Stuart treats of the Metropolitan Police.

— The *Nineteenth Century* for April (New York, Leonard Scott Publication Company, 29 Park Row) opens with a rejoinder on agnosticism, by Professor Huxley, in which he replies to the criticisms made by Dr. Wace in the March number. The Earl of Meath discusses the work of the new London Council, the body that has recently been organized for the government of London. Special importance is attached to the necessity for parks and open spaces for the poor. Lady Blake writes of seals and seal-fisheries. Viscount Powerscourt, a Liberal-Unionist, contributes some casual notes on Ireland. Mr. Scrutton, the president of the Chamber of Shipping of the United Kingdom for 1888, replies to Mr. Plimsoll's paper on marine insurance in the March issue. The Rev. Henry Sidebotham writes on Monte Carlo, pointing out the still numerous errors of the place. W. Frewen Lord describes the British dominion in the Ionian Islands, extending from 1815 to 1863, when they were ceded to Greece. He treats at some length of British misrule, a phase of English history heretofore little understood. Rowland E. Prothero discusses the question, "Is an Agricultural Department Necessary?" which is not without interest to Americans, in view of the recently established department at Washington. Sir William Gregory contributes an interesting series of reminiscences of Daniel O'Connell. Dr. Tuke writes of lunatics as patients, not prisoners. The Marquis of Lorne makes some suggestions for emigrants, with special reference to Canada. Under the head of "Noticeable Books" are brief reviews by Mr. Gladstone, Rev. Dr. Jessopp, Walter Pater, Hamilton Aide, and Frederick Harrison.

— Mr. Samuel Cabot, 70 Kilby Street, Boston, in a letter to *Building*, states that the cause of the white efflorescence on bricks has been recently investigated by him, with the result that there are at least three different substances which cause it. Of these, carbonate of soda is most common upon new work, after the limestains have been removed. This is due to the action of the lime mortar upon the silicate of soda in the bricks. Silicate of soda seldom occurs in bricks unless the clay used is a salt clay. The only other white efflorescence of importance is chiefly composed of sulphate of magnesia. This is due to pyrites in the clay, which, when burned, gives rise to sulphuric acid, and the latter unites with the magnesia in the lime mortar. The conclusions thus far arrived at are, (1) the "efflorescence" is never due to the bricks alone, and seldom to the lime alone; and (2) to avoid it, the bricks should be covered with an oily preservative capable of keeping the salts from exuding. Linseed-oil cannot fill the requirements, as it is injured by the mortar. Mr. Cabot wishes to investigate the matter still further, and will be obliged to any architects who will send him samples of this substance (say a quarter-ounce) that may come under their observation.

— The directors of the Old South studies in history and politics have included in their new general series of Old South Leaflets a leaflet containing Washington's inaugurals, — the address delivered in New York, April 30, 1789, when Washington first took the oath, and his address to Congress in 1793. This leaflet will be especially interesting at this centennial time, the first inaugural address being nowhere else so easily accessible. The account of the inauguration from Irving's "Life of Washington" is appended, and there are some useful notes. These Old South Leaflets, furnishing so many original papers to the people in such attractive form for only five cents, are a great means of education in history and politics. Washington's farewell address, which, as Senator Sherman recently said, ought to be spread everywhere broadcast among the people, is included in the series, and this deserves new attention now at the time of the Washington centennial. Lincoln's inaugurals are given in another leaflet, and it is useful to compare these with those of Washington. The leaflets are published by D. C. Heath & Co., Boston, New York, and Chicago.

— Some time ago Pau-let, the director of the Nanking arsenal, was commissioned to procure from abroad the requisite machinery for the establishment of a foundry for smelting iron in Kueichow. The machinery, which weighed 1,780 tons, reached Shanghai in three separate consignments, whence it was forwarded by boat to Nanking. Owing to the rapids and shallows in the river between Ch'ang-tê, in Hunan, and its destination, it had to be placed on frames and transhipped piece by piece. The first consignment reached its destination early in August of last year, and the remainder followed closely afterwards. A number of workmen and artisans accompanied it, and arrangements having been made for putting it together and setting it up at once, it was expected that the furnaces would be in working order within the year. The undertaking being on a very large scale, the funds raised by the issue of shares have not yet sufficed to cover the expenditure, and the governor has been asked to take steps to meet the urgent demand which exists for more money. Kueichow, the governor explains, is an extremely poor province, and its only natural production is iron. Accordingly, permission was obtained from the Throne for sending officers abroad to procure machinery for establishing a smelting-furnace in the Ch'ing district, within the prefecture of Chen-yüan, and thus develop the only resource the province possesses. The great difficulty of inaugurating such an enterprise, says the *Indian Engineer*, is shown by the fact that two years have elapsed before the machinery could be procured from abroad. It has now, however, arrived, and been put up, and the greatest part of the difficulty is over. The quality of the coal and iron obtained in the district is excellent, and the seams in the hills are exceedingly rich. The only drawback experienced has been the difficulty of raising the money at once by shares, which is, no doubt, due to the fact that the mercantile classes have suffered severely in the past from the insecurity attaching to scrip issued by similar companies, and will not be enthusiastic in subscribing to the present undertaking until they see the furnaces actually at work,

and the iron turned out. The purchase of the machinery, the erection of the buildings, and other expenses, have hitherto been defrayed by loans contracted from merchants, or by temporary appropriation from the *likin* revenue, to be repaid on the receipt of the money from the shares, which, it is expected, will shortly be forthcoming, now that there is every prospect of the foundries being brought into full operation.

— According to the report of the Massachusetts Railroad Commission, there are twelve times as many persons killed and injured at level crossings in that State as in the whole of Germany, though there are nearly twice as many of these crossings in the latter country.

— The *Engineering and Mining Journal* is authority for the statement that at Aitken, Minn., on April 2, at 4.45 o'clock, it became so dark that lights were necessary in business-houses, and the air was filled with snow that is represented to have been as black and dirty as though it had been trampled into the earth. Six ounces of snow and one-fourth ounce of dirt and sand were found in the bottom of a dish. The dirt is very fine, something like emery, and contains particles that have a metallic lustre. This dirty snow fell to the depth of half an inch. The atmosphere at the time presented a peculiar greenish tinge. There was a little wind blowing at the time from the north-west, though there seemed to be a considerable wind higher in the air. Solid chunks of ice and sand are reported to have been picked up in various places.

— A series of articles on submarine boats is now appearing in *Engineering*. Among the earlier forms mentioned is one invented during the American war of independence by David Bushnell of Connecticut, for employment against the British ships of war. It was like a walnut, somewhat flattened, and was sunk and raised by letting in and forcing out water. One oar served for sculling ahead or astern; and another, on the screw principle, placed above the operator, regulated the descent and ascent. When on the surface, an automatic tube supplied the air necessary for one person for half an hour's submersion, and another expelled it when foul. The manhole was covered with a hinged hat-like covering provided with glazed eyelets, and a manometer and compass were illuminated by phosphorus. The torpedo, containing 150 pounds of powder, clock-work, and firing spring, was secured on the top of the boat. A wooden screw manipulated ingeniously through a tube from the interior was meant to be screwed into the bottom of a hostile ship. A line connected this screw with the torpedo, which, when released, floated up by its own buoyancy against the ship's bottom. The boat was then to beat a rapid retreat, and rise again to the surface when at a safe distance. The clock-work, when the time for which it was set had run out, unlocked the striker, causing the explosion. The whole arrangements were well conceived, and, as Washington said, an effort of genius, but requiring too many things in combination for much result to be anticipated from them when employed against a watchful enemy. The boat, manned by Sergeant Lee, who had been previously well drilled in its use, sallied out against Lord Howe's flagship, lying off Governor's Island near New York, and succeeded so far as to get under her without being detected. The screw, however, would not act; and, the sergeant losing his head and his bearings, the attempt signally failed, as did two subsequent ones. Some time afterwards the vessel conveying the boat up the Hudson River was chased and sunk by a British man-of-war, and thus closed the brief career of the first diving-boat designed and used for aggressive belligerent purposes.

— The *Nationalist*, a monthly magazine soon to be issued by The Nationalist Club of Boston, Mass., will have as contributors, Col. T. W. Higginson, Edward E. Hale, Rev. W. D. P. Bliss, Cyrus Field Willard, Edward Bellamy, Rabbi Solomon Schindler, Sylvester Baxter, John Ransom Bridge, Laurence Grönlund, Rev. Albert Lawson, Gen. A. F. Devereux, Henry Willard Austin, Mrs. Mary Livermore, Mrs. Maud Howe Elliott, Mrs. Abby Morton Diaz, Miss Frances E. Willard, Miss A. A. Chevallier, and many others. The declaration of principles of the Nationalist Club reads

as follows: "The principle of the brotherhood of humanity is one of the eternal truths that govern the world's progress on lines which distinguish human nature from brute nature. The principle of competition is simply the application of the brutal law of the survival of the strongest and most cunning. Therefore, so long as competition continues to be the ruling factor in our industrial system, the highest development of the individual cannot be reached, the loftiest aims of humanity cannot be realized. No truth can avail unless practically applied. Therefore those who seek the welfare of man must endeavor to suppress the system founded on the brute principle of competition, and put in its place another based on the nobler principle of association. But in striving to apply this nobler and wiser principle to the complex conditions of modern life, we advocate no sudden or ill-considered changes; we make no war upon individuals; we do not censure those who have accumulated immense fortunes simply by carrying to a logical end the false principle on which business is now based. The combinations, trusts, and syndicates of which the people at present complain demonstrate the practicability of our basic principle of association. We merely seek to push this principle a little further, and have all industries operated in the interest of all by the nation,—the people organized,—the organic unity of the whole people. The present industrial system proves itself wrong by the immense wrongs it produces: it proves itself absurd by the immense waste of energy and material which is admitted to be its concomitant. Against this system we raise our protest: for the abolition of the slavery it has wrought and would perpetuate, we pledge our best efforts."

—Two daring Englishmen, Mr. E. W. Everest and Count de Sainville, have started from Winnipeg on an adventurous trip. They propose to descend the Mackenzie, which is nowadays easily accomplished by means of the steamer that was put on the river a few years ago. They intend to start west from the mouth of the Mackenzie, and to follow the Arctic shores as far as Bering Strait. It appears that they intend to study the Eskimo of Cape Bathurst and Point Barrow. It is expected that the expedition will occupy two years.

—Mr. George F. Kunz sails on April 20, per steamer "La Champagne," to represent Messrs. Tiffany & Co. at the Paris Exposition, and also to be acting special agent for the United States Exposition Committee, having in charge the government mineralogical and metallurgical exhibit.

—At the instance of Mr. Jules Simon, president of the commission of the history of inventions, at the great International Exhibition at Paris, it has been decided that an important part of this branch of the exhibition shall be tableaux showing the characteristic industries of each of the great epochs of the history of mankind. This plan has been taken up vigorously, and a number of tableaux have been completed. For illustrating the industries of primitive man, four groups in full size have been made,—the first makers of stone implements, the first engravers, the first architects, and the first founder. The first group represents a man and a woman. They flake the flints in the same way as the Australians continue to do up to this day, the physical and ethnological character of whom is, moreover, so much like that of the earliest inhabitants of central and western Europe. This scene has been modelled according to a sketch by Baines. The first engravers are troglodytes of the reindeer age. One of them graves relief figures on a perforated stick of the class generally called chief's batons. The other cuts small sticks which are to become needles. The group "Founding of Bronze" shows a founder casting the metal in the mould, while another man blows up the fire by means of the double bellows which have been used since the earliest times in eastern Asia. All these figures—and this is the most noteworthy part of the work—have been modelled according to skulls and skeletons of the various races,—those of Canstadt, Cro Magnon, Furforz, etc. Dr. Hamy undertook the reconstruction of the human races of these ages, and it was found that the resulting types are pretty much of the same time as many modern Europeans. The collection, furthermore, embraces Egyptian, Chaldean, Greek, and Gallo-Roman figures. Egypt is represented by a weaver reproduced

from a grave at Thebes. As a representative of Chaldæa, Gudea has been chosen, offering to his god a model of the temple of Tello. Four Greeks are shown engaged in making painted vases. Ancient France is represented by a factory of clay statuettes. The arts and industries of primitive people will be represented by a negro forger and a Samoede engraver; those of eastern Asia, by a Chinese potter; while a manufacturer of paper will represent the industries of ancient America. This collection of groups of working-men will be supplemented by collections of their manufactures.

—At a recent meeting of the Swedish Anthropological Society, Professor G. Storm read a paper on his researches relating to the Lapps. The speaker held, says *Nature*, that this race had settled in northern Scandinavia as far back as the stone age, and had not begun to move southwards until the middle ages. These southward movements had occurred periodically. At the end of the fifteenth century the Lapps had reached the sixty-fourth degree of latitude, but were now found much farther south. The subject was of interest, because of the general belief that the Scandinavians had driven the Lapps northwards. In common with others, Professor Storm was of the opinion that the Lapps belonged to the Finnish-Ugrian race.

—The second season of the Marine Biological Laboratory, of which Dr. C. O. Whitman is director, will open soon. In the investigators' department, Howard Ayers, Ph.D., and E. G. Gardner Ph.D., are assistants. In the students' department, J. S. Kingsley, Sc.D., is instructor in zoology; James E. Humphrey, S.B., instructor in botany; and Playfair McMurrich, Ph.D., instructor in microscopical technique. In addition to the regular courses of instruction, and the appointed aids in laboratory work, occasional lectures, or informal accounts of results obtained in special lines of research carried on at the laboratory, may be expected from some of those who will occupy investigators' tables. Professor E. B. Wilson of Bryn Mawr, and Professor C. S. Minot of Harvard Medical School, will be among the number of such contributors. The new laboratory is located on the shore, at Wood's Holl, Mass., near the laboratories of the United States Fish Commission. The building consists of two stories—the lower, for the use of students receiving instruction; the upper, exclusively for investigators. The laboratory has aquaria supplied with running sea-water, boats, collecting apparatus, and dredges; it will also be supplied with alcohol and other re-agents, glassware, and a limited number of microtomes and microscopes. By the munificence of friends, the library will be provided henceforth not only with the ordinary textbooks and works of reference, but also with the more important journals of zoology and botany. The laboratory for investigators will be open from June 3 to Aug. 31. It will be fully equipped with aquaria, glassware, re-agents, etc., but microscopes and microtomes will not be provided. In this department there are eight private rooms for the use of investigators not requiring instruction, who are invited to carry on their researches at the laboratory. Those who require supervision in their work, or being already prepared to begin original work, desire special suggestions and criticism, or extended instruction in technique, will occupy tables in the general laboratory for investigators, and will pay for its privileges a fee of fifty dollars. The laboratory for students will be opened on Wednesday, July 10, for regular courses of seven weeks in marine zoology and microscopical technique. Botany will be taught for the present season during August. Opportunities will be given for collecting and preparing material for use in the classroom and for special lines of study. The fee for workers in this department is twenty-five dollars, payable in advance. The number of students will be limited to twenty-five, and preference will be given to teachers or others already qualified. By permission of the director, students may begin their individual work as early as June 15, without extra charge, but the regular course of instruction will not begin before July 10. Applications for places in either department should be addressed to Miss A. D. Phillips, secretary, 23 Marlborough Street, Boston. The new laboratory is intended to continue and enlarge the work of the laboratory at Annisquam, carried on for six years by the Woman's Education Association, with the co-operation of the Boston Society of Natural History.

SCIENCE:

A WEEKLY NEWSPAPER OF ALL THE ARTS AND SCIENCES.

PUBLISHED BY

N. D. C. HODGES,

47 LAFAYETTE PLACE, NEW YORK.

Subscriptions.—United States and Canada.....	\$3.50 a year.
Great Britain and Europe.....	4.50 a year.
Science Club-rates for the United States and Canada (in one remittance):	
1 subscription 1 year.....	\$ 3.50
2 " " 1 year.....	6.00
3 " " 1 year.....	8.00
4 " " 1 year.....	10.00

Communications will be welcomed from any quarter. Rejected manuscripts will be returned to the authors only when the requisite amount of postage accompanies the manuscript. Whatever is intended for insertion must be authenticated by the name and address of the writer; not necessarily for publication, but as a guaranty of good faith. We do not hold ourselves responsible for any view or opinions expressed in the communications of our correspondents.

VOL. XIII. NEW YORK, APRIL 19, 1889. No. 324.

CONTENTS:

THE LOOMIS ELECTRIC-LIGHT SYSTEM.....	292	NOTES AND NEWS.....	298
AVRTON AND PARRY'S IMPROVED AND NEW AMMETERS AND VOLTMETERS.....	293	EDITORIAL.....	302
AN ELECTRIC DOOR-OPENER.....	294	Stanley's Explorations as affecting our Knowledge of Central Africa.....	
BUILDING-STONES OF EAST TEXAS.....	295	THE STUDY OF THE DEAF.....	302
TEXAS ASPHALTUM.....	295	THE MARINE BIOLOGICAL LABORATORY.....	303
EXPLORATION IN MEXICO.....	295	REPORT OF THE HEALTH-OFFICER OF THE PORT OF NEW YORK.....	304
HEALTH MATTERS.....		BOOK-REVIEWS.....	
Baking-Powders.....	296	The Student's Atlas.....	305
Quarantine Conference.....	296	AMONG THE PUBLISHERS.....	305
Treatment of Obesity.....	297	LETTERS TO THE EDITOR.....	
ELECTRICAL NEWS.....		The Robinson Anemometer.....	
The Clark Cell as a Source of Standard Currents.....	297	H. A. Hazen 307	
The Detroit Secondary Battery.....	297	Surveys, their Kinds and Purposes.....	
The Magnetic Properties of Nickel.....	298	Herbert G. Ogden 307	
A Challenge to the Westinghouse Company.....	298	English Examinations.....	
The Conductivity of Mica at High Temperatures.....	298	Peter T. Austen 309	

AN IMPORTANT QUESTION upon which Stanley's journey, according to his recent letter, may throw light, is the doubtful connection of the Mootan Nzige with the Aruvimi or with the Albert Nyanza. From a passing mention of this question in the letter, it would appear that Stanley inclines to the opinion that the lake belongs to the Kongo system. He states that it is far smaller than the Albert Nyanza, and this statement necessitates an important change in our maps of Central Africa. Mr. Wauters of Brussels, whose opinions regarding the hydrography of the Kongo basin deserve special consideration, has long maintained that the lake must belong to the Aruvimi system, as it would be impossible to account for the enormous amount of water carried by that river if it had its source west of the lake. Other geographers, among them A. Kirchhoff, have maintained the existence of a connection between the southern lake and the Albert Nyanza. In this case, the lake would belong to the Nile system. Undoubtedly Stanley's explorations will materially add to the solution of this interesting problem. His whole route led to entirely unknown territory, and will disclose another section of the western slope of the great East African highlands. Among the ethnographical notes contained in his letter, the discovery of a new tribe of dwarfs, called Wambutti, is noteworthy, as they add one more to the great number of these widely scattered dwarfish people which have become known recently. The Wambutti occupy an intermediate location between the Akka

of the Welle, and Batwa of the southern Kongo affluents. The natives, among whom these dwarfs live, are described as "strong, brown-bodied, with terribly sharp spears,"—a description which shows that they belong to the group of the peoples inhabiting the watershed between the Welle and Nile, and not to the Bantu.

THE STUDY OF THE DEAF.

The April number of the *American Annals of the Deaf* contains much valuable information of a general as well as of a special nature. Professor Greenberger, in speaking of the difficulty often experienced in ascertaining whether a deaf-mute is idiotic or not, narrates a number of instances in which children have been placed in idiot-asylums who afterwards proved to be quite intellectual. He says that the brightest pupil, without exception, that he has ever had under his charge was a semi-deaf boy, who, on account of his partial hearing, had been mistaken for an idiot, and placed in a school for feeble-minded children before he was sent to a deaf-mute institution. He afterwards became an able editor and part-owner of a newspaper.

W. G. Jenkins, M.A., contributes a very valuable article on diction and idiom, and points out the great difficulty which learners of the English language experience in mastering it.

"At the end of four years, the ordinary pupil is in possession of a vocabulary of three or four hundred words. His habit of composition has become pretty well fixed by that time, and his later acquisitions are but expansions of the work already begun. The skeleton has been formed, and the more meat that can be added, the more satisfactory will be the result. The first three or four hundred words in a deaf pupil's vocabulary are short, easy words; and a suggestion to discourage synonyms is nothing else than a plea that the easy Saxon words already acquired be retained, in preference to the longer Latin equivalents. If a pupil has been taught to write, 'Mr. Smith built a house,' it would be better for him, to the end of his life, to use those words, when necessary, than to write, 'Mr. Smith erected a residence.' I do not think there can be two opinions on the wisdom of urging our pupils to use such words as 'buy,' 'lead,' 'begin,' 'hate,' 'end,' 'go,' 'hide,' 'whip,' 'letter,' 'famous,' in preference to 'purchase,' 'conduct,' 'commence,' 'abominate,' 'terminate' or 'conclude,' 'proceed,' 'conceal,' 'chastise,' 'epistle,' and 'illustrious.' It is desirable that our pupils should know every word they meet, but it is not desirable to use synonyms for the language already in their possession. To encourage the use of long words for the short, easy words already familiar, would bring us under Goldsmith's criticism of Dr. Johnson, of 'making minnows talk like whales.' The boy who wrote of making shoes on a conclusion (last), and the one who fermented on his father's farm, together with the Frenchman who wrote to his English friend, praying that 'he and his family might be pickled to all eternity,' might have expressed themselves very clearly had they been less ambitious for synonyms.

"If it were only possible to find out what words were best adapted to the requirements of every-day life, and what number could be practically taught in the few years at our disposal, a valuable aid in the work of instruction would be secured. Of the one hundred and fourteen thousand words in the English language, we must make up our minds to dispense with all but a thousand when we consider the written language of the deaf. The mastery, indeed, of five hundred words would be a most gratifying accomplishment. It is claimed, by no less an authority than Max Müller, that a well-educated English scholar, a representative of the best university, one who is familiar with Shakspeare and Milton, does not use more than three to four thousand words. The Hebrew Testament says all that it has to say in 5,642 words, while an English author says that in his parish the rural laborers have not more than three hundred words. However much we may mourn over it, the fact remains, that, if our pupils are to express themselves in grammatical language, we must be content with a limited vocabulary; and it is much to be feared that time spent in technical studies, in memorizing technical phraseology, is so much time taken away from practice in the language of the common people."

A. L. E. Crouter, M.A., contributes an article on the proper lo-

cation of an institution for the deaf, style of buildings, and best methods of lighting, heating, and draining. Among miscellaneous matter treated in the *Annals* we notice two reported cases of so-called cures of deafness by the "faith-cure" and "Christian science." One of these was a boy living in Japan, who was said to have had his hearing restored by the prayer of missionaries. This case was investigated by a trustworthy gentleman living in Tokio, where the case occurred. He writes: "The only foundation for the story of his cure by prayer was that at the time of the effort made in his behalf he seemed, or was imagined by those who so eagerly watched him, to hear the sound of the school-bell. I judge, from all I can gather, that there is nothing in the case which the intent watching of those interested will not readily account for."

The *Oregon Sign* remarks as follows on a reported restoration to hearing of a former pupil of the Oregon School by "mind-cure" or "Christian science": "A Portland daily paper of a recent date names among others Miss Mary Lance, a deaf-mute young lady long a pupil in this school, as having her hearing partly 'restored' by nine 'treatments' by a 'mind-cure,' or so-called 'Christian science,' doctor. Miss Lance writes to friends here that she is as deaf as ever, and expects to return to school. There is, no doubt, science that is Christian, and Christianity that is science; but there is a great deal in the world that is neither science nor Christianity, for quackery has nothing to do with either. Newspapers do a great injury when they publish such nonsense, as deaf children are often kept out of school by a false hope that they may be cured."

THE MARINE BIOLOGICAL LABORATORY.

FROM Liebig's "*Welt im Glase*" arose the idea of public marine aquaria, first developed in London, then in many other cities on the Continent. The institution became popular, not only as a means of amusing and instructing the general public, but as an invaluable source of instruction for schools and universities. The hope was entertained for a time that such inland aquaria could be made useful to scientific men for the study of marine life. It soon became evident, however, that such study could be successfully prosecuted only at the seashore. The marine laboratory, with its aquarium, followed. The idea of maintaining marine stations for scientific work was first acted upon by Carl Vogt in Europe, and by Louis Agassiz in America; while one of the earliest, and by far the most successful, undertakings of this kind that the world has yet seen, is represented in the Naples Station, founded and directed by Anton Dohrn. The history of that institution has been often repeated, and is doubtless familiar, in all its essential features, to most of our readers. It is enough to say that it is an example of just what we have long needed in America.

"But what are the special attractions of marine life, that naturalists should so eagerly seek the seashore?" is a question sometimes asked. To this we may reply, that the ocean is the home of the lowest as well as the oldest forms of life, and it is in such forms that the mysteries of life can presumably be most nearly approached. Then there are abundance and variety, and certain important groups that do not occur in fresh water. To the luxuriance of the fauna and flora of the shore, is added that vagrant, pelagic life which is collected by ocean-currents, tides, and winds, and laid at one's feet as freely as if all nature pleaded for investigation. Moreover, the study of marine life has long been inadequately provided for, its advantages not having been generally recognized until within the last fifteen or twenty years. The comparative newness of the field, its infinite richness, and its importance in determining the origin, history, and relationships of living forms, account for the intense interest recently awakened in marine laboratories.

The new laboratory at Wood's Holl is nothing more than a first step towards the establishment of an ideal biological station, organized on a basis broad enough to represent all important features of the several types of laboratories hitherto known in Europe and America. It should be provided eventually with means for sending men to different points of the coast to undertake the investigation of subjects of special interest, thus adding to the advantages of a fixed station those of an itinerant laboratory.

The Marine Biological Laboratory is an outgrowth of a seaside laboratory maintained at Annisquam, Mass., from 1880 to 1886, by the Woman's Education Association of Boston, in co-operation with the Boston Society of Natural History. In 1886, efforts were made by the association to place the laboratory on an independent and broader foundation. A circular letter was addressed to many of the leading biologists of the country, reciting what had been already done at Annisquam, and asking for co-operation and counsel. The replies received were most encouraging, testifying to a general and hearty approval of the enterprise, and promising co-operation and support.

Accordingly, invitations were issued, and a preliminary meeting was held on March 5, 1887, in the library of the Boston Society of Natural History. Numerous addresses were made, and a committee was appointed to perfect plans for the organization of a permanent seaside laboratory, to elect trustees, and to devise ways and means for collecting the necessary funds.

The funds having at length reached such an amount as was deemed adequate to a modest beginning, the necessary steps were taken; and in March, 1888, the laboratory was incorporated under the name of the Marine Biological Laboratory, and the following were chosen officers of the corporation: trustees, William G. Farrow, Edward G. Gardiner, Alpheus Hyatt, Susan Minns, Charles S. Minot, William T. Sedgwick, Samuel Wells; treasurer, William Stanford Stevens; clerk, Anna D. Phillips. The trustees immediately organized, and elected Professor Alpheus Hyatt president, and Miss A. D. Phillips, secretary. Professor Farrow soon after resigned, and Professor E. L. Mark was chosen as his successor. Dr. Gardiner, who had kindly consented to enter the board to fill a temporary vacancy, also soon withdrew, and Miss Florence M. Cushing was chosen in his stead.

The trustees, who had already, through a committee, instituted thorough inquiries as to the best place for the laboratory, now set themselves actively to work to locate it, to build and equip it, and to make the necessary plans for the summer's work. Although the time was unduly short, and differences of opinion as to location, policy, etc., difficult to reconcile, had to be harmonized, it was still deemed wise to make a beginning at once, and, if possible, to open the laboratory in 1888. Accordingly, after prolonged and careful consideration, a piece of land (78 x 120 feet) was purchased at Wood's Holl, Mass., close to the shore, and near the buildings of the United States Fish Commission. A plain but very substantial building, 63 x 28 feet, and two stories high, was erected, and was completed within the specified time and at the estimated cost. It was equipped with unusual thoroughness, and was finally opened for work on the day appointed; viz., July 17, 1888.

Dr. C. O. Whitman had already been appointed director of the laboratory, and Mr. B. H. Van Vleck, instructor. Two circulars were issued in June, much later than could have been desired, announcing the opening of the laboratory, and stating the facilities to be provided for investigators and students. One was addressed chiefly to teachers and other workers; the other, to colleges likely to be specially interested. It was so late, however, before it was deemed safe to issue them, that no great response was looked for, or, in fact, occurred.

On the opening day, a small company of students, investigators, and invited guests were present, and the laboratory was formally opened with an address by the director (see *Science*, xii. p. 37). Somewhat earlier than this, Mr. Joseph S. Fay had signified to the trustees his willingness to place at their disposal for the season, a small house on the main street of Wood's Holl, known as "Gardiner Cottage." This gift was most timely, as it enabled the trustees to establish headquarters for the board and lodging of those connected with the laboratory, and contributed directly to its attractiveness and success, as well as to the comfort and welfare of the students.

Owing to the uncertainty connected with the finishing and equipping of the laboratory, it was not possible to issue public circulars until many colleges had disbanded for the summer, and students generally had formed other plans. Nevertheless, during the season there were connected with the laboratory eight students and seven investigators.

The laboratory has now made a beginning. It has secured a

solid foundation and a sound working organization. On what has thus far been done there is every reason for congratulation. This is, however, but the mere beginning of what there should be. More room will soon be needed, more and better boats. A special landing-place must shortly be purchased. An increased equipment of microscopes and aquaria will certainly have to be provided. A working library of good size and quality, placed in the laboratory itself, is absolutely indispensable. The indications point to a large influx of investigators and students, and the trustees foresee the possibility of more applicants than they can accommodate. To meet these new needs and emergencies, more funds are urgently demanded; and the trustees earnestly appeal to the corporation, and to the supporters of science everywhere, for sympathy and active support, so that they shall be enabled to carry on aggressively a work already begun, and proven not only possible but worthy.

REPORT OF THE HEALTH-OFFICER OF THE PORT OF NEW YORK.

THE annual report of the health-officer of the port of New York, Dr. William M. Smith, to the Board of Commissioners of Quarantine, contains much valuable statistical and other material. During the year 1888, 5,291 vessels arrived at New York from foreign ports, and 1,053 from domestic ports, which are subject to quarantine regulations. As compared with 1887, the number from foreign ports was less by 637. Dr. Smith states that the arrivals are diminishing each year, and gives figures to sustain this statement. The number of steerage passengers inspected by the medical officers of the department was 383,595, arriving by more than twenty different lines of vessels; the North German Lloyds bringing the largest number, 52,926. In speaking of this subject of immigration, Dr. Smith says: "There are few subjects of greater importance for the consideration of maritime quarantine officials, and of our municipal health authorities, than the immense immigration which has been flooding our country for the past nine years, and which there is reason to believe will continue for years to come. The same political and economic conditions which existed in 1879, when the immigration from the Old World increased from 135,020 in that year, to 327,371 in the year following, have continued to this time, and bid fair to obtain for years to come. Our vast unsettled area of country is likely to continue to invite, and the inexhaustible resources of our mines and forests will stimulate, an exodus of the surplus population of Europe for a long period in the future. Under these circumstances, it is the duty of health authorities to adopt such measures at ports of entry for immigrants as will contribute to land them upon our shores in such physical condition that they will add to the material prosperity of the country, instead of taxing its resources and increasing its burdens. Those who derive a profit from the transportation of immigrants, as well as those who come to share the blessings which our country affords, are under obligations to supply all the means and to take all the precautions necessary to secure the health of immigrants, and protect our communities from the diseases, developed or latent, with which they too frequently come hand in hand. Improper or insufficient food, imperfectly ventilated and overcrowded steerages during the voyage, are far too frequent. During the early part of the year 1888, the steamer 'Comorin' arrived with 1,263 immigrants; the 'Cachemere,' with 1,411; the 'Bohemia,' 1,280; 'Chateau Yquem,' 1,228; 'Alesia,' 1,018; and the 'Cashar,' with 1,520. These poor people were crowded between decks most of the time for two weeks, and some for twenty days. During the cholera epidemic in 1887, among the passengers of the 'Alesia' there was a larger percentage of deaths among those taken sick during the voyage than among those who suffered from the disease while in quarantine. While the passengers of the steamer 'Britannia' were detained at quarantine the same year on account of cholera, an epidemic of measles developed among them. The symptoms in most cases were more severe, and the fatality much greater, than is usual in that disease, the percentage of fatal cases being something more than fifteen per cent. There is no cause of death given so frequently by the surgeons of immigrant passenger-steamers as *marasmus*. The diagnosis should be

starvation. The victim is always a child at the breast. The mother, prostrated by seasickness, her vitality depressed by the crowd-poisoned air of the steerage, and exhausted for want of proper food, is unable to supply the child with sufficient nourishment. The immigrant mother often ceases entirely, for the time being, to afford her infant its accustomed food. The child is then given the only substitute, the coarse fare of the adult immigrant: indigestion, diarrhoea, and death are often the result."

In speaking of contagious diseases among immigrants, Dr. Smith says that small-pox continues to be one of the most frequent, and is by far the most difficult, latent contagion to arrest by maritime quarantines. The incubative period of the disease being fourteen days, and the average passage of steamers from ports of Europe and the British Isles several days less than that time, the disease may be contracted at the port of departure, or in the interior of Europe, and not develop until the immigrant reaches some far interior community in this country. To prevent or limit to a possible minimum the importation of this contagion has enlisted more earnest effort, and has been productive of more anxious reflection on the part of the health-officers, than any other subject during the past nine years. He recommends that all persons who have not been vaccinated within six or eight years should be vaccinated within the first two days after they go on board ship.

The history of the yellow-fever which occurred on the United States Cruiser "Boston" and the United States sloop-of-war "Yantic" is given in considerable detail. In discussing the origin of the fever on these vessels, Dr. Smith says that neither the "Boston" nor the "Yantic" received anything on board from the shore, while at Port au Prince, except meat and fruit. The fruit, consisting of bananas and oranges, was taken to the vessels by natives in what is called "bumboats," and sold to those on board. The main decks of the "Boston" and "Yantic" are so low, that communication between those on them and the "bumboats" was easy, and doubtless frequent, while the natives were vending their fruit. The wet, dirty, and sun-heated bottoms and timbers of the boats of the natives, exposed, as they must be at all times when at the shores or wharves, to an infected atmosphere as well as to the infected filth of the gutters that drain into the bay, certainly supply all the conditions necessary for the propagation of the infection. It would be rather a matter of surprise than otherwise, if the boats of the natives were not impregnated with the infection of yellow-fever when it prevails at Port au Prince. The history of the disease on the "Boston" and the "Yantic" affords satisfactory evidence to Dr. Smith that the persons who suffered from it contracted the infection while at Port au Prince, and that the infection did not infect either vessel; in other words, that the infection was limited to the individuals who contracted the infection at that port.

Dr. Smith refers to the disappearance of cholera from Europe and America. The confident prediction, he says, has not been fulfilled, which was frequently made by wiseacres during the winter of 1887-88 and until the spring of 1888 was well advanced, in reference to the cholera infection among the passengers of the "Alesia" and "Britannia" in the fall of 1887; to wit, that the germs of the disease had escaped with the baggage when the immigrants were released from quarantine, and would be propagated the ensuing summer until the disease developed into epidemic proportions. The history of this terrible disease since its first advent in Europe in 1829-30 warranted the suspicion that its arrival at our quarantine was the forerunner and herald of a disastrous epidemic of cholera throughout our country. There are but few instances in the history of this disease in which it has not become epidemic in a country soon after it appeared at its threshold. He gives the following interesting history of the cholera during recent years:—

"In 1882 cholera commenced its deadly march from its home in the Ganges. Its first attack was upon Aden on the Red Sea. Early in 1883 it appeared at Damietta in Egypt, and in June of that year reached Cairo, and subsequently extended to most of the cities and towns of Lower Egypt. Those familiar with the history of cholera then confidently predicted its speedy advent in Europe. These predictions were fulfilled early in the ensuing summer. The first victims of the disease in Europe were at Toulon in the early part of June, 1884. It reached Marseilles the 28th of the same

month, and in a few weeks decimated all the towns in the south of France. Although the Italian authorities on the boundaries between France and Switzerland attempted to stay the progress of the epidemic by imposing the most rigid system of quarantine of all persons and things from infected localities, the disease had passed all sanitary cordons before the end of August, and was numbering its victims daily by hundreds in various parts of Italy. Despite every effort of the health authorities, it crossed the Pyrenees early in 1855, and began the work of destruction in Spain. Before the close of the year it had counted more than a hundred thousand victims in that country. The year following (1856), a passenger-steamer with Italian immigrants landed the pestilence at Rosario, in South America. The *cordon sanitaire* established in the passes of the Andes by the States of the west coast of South America did not prevent the disease from reaching and ravaging many of the great cities and towns on the western coast. Sept. 23, 1857, and again in the month following, cholera sought to invade our country through Italian immigrants, as it had done in South America the year previous. The story of its advent, arrest, and destruction at quarantine, has been told in my report for 1857. In the five previous invasions of Europe by this disease during the present century, it had succeeded in every instance in reaching our shores, and developing into epidemic proportions. The failure of the pestilence to secure a foothold in our country last year was a triumph, but under difficulties such as the quarantine officials at this port, it is hoped, may not again be called upon to encounter."

Extensive repairs and improvements are now in progress at the quarantine establishment, which will, in the opinion of the health-officer, supply all the conditions necessary to secure the country from any possibility of an epidemic of infectious or contagious disease which may approach from the sea. For this purpose the Legislature has appropriated \$121,843. The disinfecting-rooms are thus described. The disinfecting-rooms are divided into three airtight compartments, with sides and ceilings made of four-inch oak plank covered with felt and galvanized iron, with doors and levers to each compartment; the outer walls of brick being built hollow so as to retain the heat. The floors are concrete and asphalt, on iron beams and masonry arches. The size of the disinfecting-rooms are two 14 by 19 feet, and one 12 by 19 feet, each 7 feet high. Each disinfecting compartment will be supplied with wire baskets supported on rollers, large enough to hold one immigrant's baggage, arranged in tiers with sufficient interspace to insure the admission of hot or moist steam with the least possible obstruction. The arrangement contemplates the use of moist steam for a few moments before the introduction of superheated steam. The introduction of moist steam first will secure the destruction of the disease germs by superheated steam more certainly and at less temperature, and thereby lessen the danger of injury of the fabrics exposed to a high temperature. In the boiler-room underneath will be placed exhaust-pumps with separate connections to each room, that the air can be exhausted; so that the articles to be treated may be easily penetrated by the moist steam, as well as other chemicals that may be used in the disinfecting process. The rooms, after being used, will be ventilated into a shaft surrounding the boiler-flue. The superheater will be located under the disinfecting-room, with all the necessary apparatus outside of the rooms, showing pressure and temperature.

In 1857 Dr. Smith recommended that a crematory be erected on Swinburne Island, for the cremation of those who die of contagious disease. This was deemed advisable on account of the unfavorable location of the burial-ground at Seguine's Point, near the extreme southern portions of Staten Island, and ten miles from the hospital. Twenty thousand dollars has been appropriated for the purpose, and the quarantine commissioners have been empowered to cause to be incinerated in such crematory the bodies of persons dying at the quarantine hospital from contagious or infectious diseases; provided, however, that "they shall not incinerate the bodies of any persons, dying as aforesaid, whose religious views as communicated by them while living, or by their friends within twenty-four hours after their decease, are opposed to cremation."

THE Eiffel Tower has now attained its full height of 984 feet.

BOOK-REVIEWS.

The Student's Atlas. By RICHARD A. PROCTOR. London and New York, Longmans, Green, & Co. 8°. \$1.50.

THE object of the present atlas is not to convey detailed information on the geographical conditions of limited areas, but to teach the relations between continents and oceans,—an important part of geography-teaching, which has hitherto been sadly neglected. The author says in his introduction, "In studying the geography of the earth as a whole, in considering the larger problems of geology, in reading history ancient and modern, in discussing problems relating to trade and commerce, and in dealing with many other subjects of inquiry, occasion constantly arises for the means of recognizing clearly and readily the relations of the different parts of the earth to each other. An ordinary atlas shows us Europe and it shows us North America, but it presents the two continents on different scales, and, except in the imperfect maps of the two hemispheres or the still more misleading Mercator's charts, it does not show how the two continents are situated with regard to each other. Of the Atlantic Ocean, which is almost as important and interesting a region of our earth as any continent, the ordinary atlas gives no map at all. Any one who wishes to note the nature and relative directions of the tracks across the Atlantic between different parts of the surrounding shores can learn nothing from an ordinary atlas except what is false and misleading. It is the same with all the oceans." For such reasons, which cannot be remedied in an ordinary atlas, the author considers it desirable to have a companion atlas, treating the earth as a whole. The plan the author has pursued is to divide the earth's surface on the twelve faces of the dodecahedron, each map being made to include the spherical surface circumscribing the pentagonal face of the dodecahedron. Thus each map embraces a little more than one-tenth of the earth's surface, and overlaps with the five neighboring maps, thus giving a good understanding of the relative position of the parts of the earth's surface. The projection chosen is Postel's equidistant projection, the centre of each pentagon being taken as the centre of the projection. This results in comparatively small distortion of scale and angle. The maps are well executed; the political divisions are designated by different colors. The topography is very sketchy. The course of ocean-currents is indicated.

AMONG THE PUBLISHERS.

THE Century Company have just completed their monumental work on the "Battles and Leaders of the Civil War." An index to the four volumes is appended to the thirty-second and final part. In concluding this handsome and valuable work, the publishers may justly feel proud of the achievement.

—C. W. Bardeen, Syracuse, N.Y., will publish May 15 an interesting historical guide-book entitled "Carleton Island in the Revolution: the Old Fort and its Builders," with notes and brief biographical sketches, and illustrations by Carleton.

—Belford, Clarke, & Co. will publish shortly William H. Herndon's "Life of Abraham Lincoln." Mr. Herndon was for some years the law-partner of Abraham Lincoln, and knew him perhaps as intimately as any person apart from his immediate family.

—The M. L. Holbrook Company have just ready "Studies of the Outlying Fields of Psychic Science," a work by Hudson Tuttle, who aims to explain the vast array of facts in his field of research by referring them to a common cause, and furnishes nearly fifty pages of "personal experience and intelligence from the sphere of light."

—People who are interested in the prohibitory amendment which is now before the State of Massachusetts for popular vote, will find a concise statement of the entire legislation in recent years in "Ten Years of Massachusetts," by Raymond L. Bridgman, published by D. C. Heath & Co. of Boston. It includes the years 1878 to 1887; and among other important enactments of that period, are the civil damage law, the screen law, the schoolhouse law, and the temperance text-books law. Every new effort of the State to repress liquor-selling is mentioned, and the text of the most important passages is given *verbatim*.

— Harper & Brothers have just ready "Further Reminiscences," a second volume of "My Autobiography and Reminiscences," by W. P. Frith, the distinguished Royal academician. The interest of the new volume upholds the reputation gained by the first. One chapter contains letters and recollections of Charles Dickens; another recalls Sir Edwin Landseer; still another, devoted to Mrs. Maxwell, whom novel-readers perhaps know better as Miss M. E. Braddon, tells, among other things, about the plan she proposed to Mr. Frith for a pictorial dramatic series on the lines of Hogarth, and how the artist shrank from the painfulness of the "terrible tragedy" which she outlined. Du Maurier and John Tenniel, the famous *Punch* artists, figure in a chapter on "Book Illustrators;" and a host of other familiar names appear elsewhere, such as Robert Browning, John Ruskin, Thomas Hardy, Mrs. Lynn Linton, F. Anstey, and Anthony Trollope. They have also just ready the third edition, revised and enlarged, of C. K. Adams's "Manual of Historical Literature;" "The Mouse-Trap and Other Farces," by W. D. Howells, including among the other farces, "The Garroters," "Five O'clock Tea," and "A Likely Story," all of which, as well as "The Mouse-Trap," C. S. Reinhart has illustrated. Another book just ready is "The Tramp at Home" (illustrated), by Lee Meriwether, special agent of the Bureau of Labor Statistics at Washington, and author of "A Tramp Trip." The book contains an account of the incidents, amusing and otherwise, which befell him in the course of his study into the condition of the American working classes. Adventure, novel experience, and humorous episode are combined with original and striking testimony bearing upon social problems in the United States.

— We take the following items from *The Publishers' Weekly*: M. Taine's health has sufficiently improved to permit him to resume his literary work, and it is said that a series of three articles by him, on "The Reconstruction of France in 1800," will appear

at once in the *Revue des Deux Mondes*. F. Marion Crawford is writing a book on Sir John Hawkwood for the English Men of Action Series. Mr. Walter Besant will prepare the volume on Capt. Cook; Mr. Clark Russell, that on Dampier; and Mr. Archibald Forbes, that on Havelock. Andrew D. Mellick, jun., Plainfield, N.J., has in preparation a work to be entitled "The Story of an Old Farm, or Life in New Jersey in the 18th Century," a semi-social, semi-historical study. The author intends to describe quite fully early German immigration to the American colonies, to vindicate the Hessian troops, and to do justice to the New Jersey Loyalists.

— Mr. Thomas S. Townsend of New York City has been at work since the beginning of the civil war, collecting, sifting, and classifying material, some of which he has now formed into a volume to be called "The Honors of the Empire State in the War of the Rebellion," and to which he calls attention. It will be issued through the Putnams as a subscription-book as soon as sufficient orders have been received to pay the cost of a first edition. Such orders should be sent to Mr. Samuel O. Fields, Library of Columbia College. On Decoration Day some years back, Mr. Townsend delivered an address before the Long Island Historical Society, which contained the germ he has brought to fruit in this volume.

— T. Y. Crowell & Co. will publish at once Bourrienne's "Memoirs of Napoleon Bonaparte," edited by Col. R. W. Phipps of the Royal Artillery. The edition is in four volumes, and is a reproduction of the latest English edition, containing all the notes, portraits, medallions, maps, etc., with the addition of several facsimile autographs and a full index. They will publish shortly "A Popular History of the French Revolution," by Mrs. Lydia Hoyt Farmer, which is based on the latest French and English authorities.

ONE LANGUAGE FOR THE WHOLE WORLD.

WORLD-ENGLISH:

THE UNIVERSAL LANGUAGE. 25 CENTS.

EVERY one has heard of the butcher who, after a long search for his knife, at last found it in his mouth: so speakers of English have been seeking for a universal language, when, lo! it is in their mouths. The intelligibility of English words has been obscured by a dense mist of letters. This is now dispersed by A. Melville Bell, who has already won a world-wide reputation through his invention of "Visible Speech," the great boon to deaf-mutes. Professor Bell calls this new discovery of his "World-English," and the result is a language which cannot fail to meet with acceptance, and at once supersede the supposed necessity for "Volapük," or any other artificial language. No language could be invented for international use that would surpass English in grammatical simplicity, and in general fitness to become the tongue of the world. It is already the mother-tongue of increasing millions in both hemispheres, and some knowledge of the language is demanded by all educated populations on the globe. Social and commercial necessities require that the acquisition of this knowledge shall be facilitated, and it is believed that Professor Bell's invention has removed the last impediment to English becoming the universal language, for which vague desires have long been entertained, although hitherto only futile efforts have been made.

Ex-President Andrew D. White, of Cornell University, says: "I believe that the highest interests of Christian civilization and of humanity would be served by its adoption. China and Japan would be made English-speaking peoples within fifty years, and so brought within the range of Christianizing and civilizing ideas, in the largest sense. All existing missionary work is trivial as compared with this. For your system would throw wide open those vast countries, as, indeed, all the countries of the world, to the whole current of English and American thought."

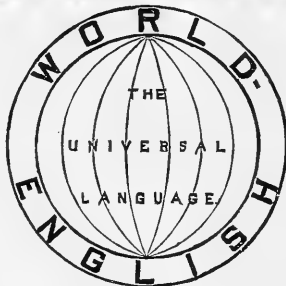

For Diffusion of English throughout the World

AS

THE UNIVERSAL LANGUAGE

This "Hand-Book of World-English" is the Complete, Simple, and Efficient Medium.

FOREIGNERS

Will Acquire, by Means of this Hand-Book, a PERFECT PRONUNCIATION OF ENGLISH. For Primary School Pupils and Illiterate Adults

World-English is a Royal Road to Reading.

To Teachers of English and Modern Languages This Hand-Book will be of Primary Importance as a Phonetic Directory.

DEFECTS OF SPEECH

Will be Readily Corrected by Means of the Articulative Directions in this Hand-Book.

HAND-BOOK OF WORLD-ENGLISH,

25 CENTS.

The plan of this little book is altogether new. Letters and sounds are so associated, in all the exercises, that from the mere knowledge of letters a learner cannot fail to pronounce words with certainty. English reading will thus be easily acquired, whether by natives or foreigners, children or adults.

The general resemblance of World-English to Literary English is such that any reader of the latter deciphers the former at sight, or, at most, after a few minutes' study of the new letters. A like result may be anticipated for those who shall learn to read from World-English. They will transfer their power of reading to the literary form of the language, almost without effort. The orthographic aspect of words will, besides, be so fixed in the eye, by contrast, that spelling will be remembered as — what it really is — a pictorial association with words.

No special training is required to qualify teachers for using this book. The subject can even be successfully introduced in the kindergarten and the nursery. This phonetic mode of initiation in reading cannot be too strongly urged on the attention of School Boards on both sides of the Atlantic.

The ordinary orthography of each word is interlined with the World-English version throughout the Exercises and Readings.

So set down, our tongue is the best for the world to unite upon.—*Brooklyn Eagle*.

The idea of Mr. Bell has much to recommend it, and the presentation is charmingly clear.—*American, Phila.*

The result is a language which cannot fail to meet with acceptance.—*Boston Traveller*.

Has the merit of great ingenuity.—*Railway Age*.

His treatise, as a study of English orthoepy, condenses the result of much thought and experience in small compass.—*The Celtic*.

World-English deserves the careful consideration of all serious scholars.—*Modern Language Notes*.

World-English is the English language unburdened of its chaotic spelling.—*Popular Science Monthly*.

We commend it to the attention of teachers.—*Ottawa Globe*.

"World-English" and "Hand-Book of World-English" can be had of all booksellers, or will be sent for 50 cents, post free, by the publisher,

N. D. C. HODGES, 47 Lafayette Place, New York.

— Scribner & Welford have just imported a unique example of book-making in the "Mulum in Parvo Atlas of the World." It contains ninety-six double-page maps, a large amount of statistics, and an index covering over one hundred pages, all in shape and size for the pocket. They have just ready a volume of poems and translations by W. J. Linton, the well-known engraver. He privately published, before this, two volumes of poems, both in very limited editions, and now very scarce. In this volume nearly all the poems in those two volumes are included; and, besides new poems, a number of new renderings of French poems, in the original metres, are included.

— Roberts Brothers announce for early publication the second volume of Renan's "History of the People of Israel," covering the period from the reign of David to the capture of Samaria, 721 B.C.; and "French and English," a comparison between these great nations in literature, science, and art, by Philip Gilbert Hamerton.

— Macmillan & Co. will act as the American agents of Sonnenschein & Co.'s new Library of Philosophy. This library is to consist of a series of works edited by J. H. Muirhead, and arranged in three departments, dealing respectively with schools of philosophers, the history of thought in particular departments, and the subject-matter of philosophy treated from an original point of view. In the first series, which will, it is expected, ultimately cover the entire history of thought in the fields of metaphysics and ethics, the following volumes have already been promised: "Sensationalists: Locke to Mill," by W. S. Hough of Ann Arbor, Mich.; "Modern Realists: Leibnitz to Lotze," by Professor Andrew Seth of St Andrew's; "Early Idealists: Descartes to Leibnitz," by W. L. Courtney of New College, Oxford; "Scientific Evolutionists: Comte to Spencer," by Professor John Watson of Kingston, Canada; "Utilitarians: Bentham to Contemporary Writers," by W. R. Sorley of Trinity College, Cambridge; "Moral Sense Writers: Shaftesbury to Martineau," by Professor William Knight of St. Andrew's; and "Idealistic Moralists: Kant to Green," by Professor Henry Jones of University College, Bangor, Me. Of the volumes of the second series, already arranged for, may be mentioned a "History of Logic," by Professor George S. Morris of Ann Arbor, Mich.; "History of Psychology," by Professor Adamson of Owens College; "History of Political Philosophy," by D. G. Ritchie and J. H. Muirhead; "History of Economics," by Dr. J. Bonar; "History of Æsthetics," by A. Bosanquet; and "Evolution of Theology," by Professor Otto Pfeleider. As an introduction to the library, Erdmann's (smaller) "History of Philosophy," in three volumes, has been translated by Dr. W. S. Hough of Ann Arbor, Mich., and will appear very shortly.

— Macmillan & Co. have just ready F. Marion Crawford's latest novel, "Greifenstein," the scene of which is laid in South Germany, principally in the Black Forest. Some charming bits of German university life are given.

— D. Appleton & Co. have just ready "The History of Ancient Civilization," a handbook based upon M. Gustave Ducoudray's "Histoire Sommaire de la Civilization," a recent French work that has been highly commended by European critics, edited, revised, and extended by Rem. J. Verschoyle. The second part of the work, treating of modern civilization, will appear shortly. They have also just ready "The Ladies' Gallery," by Justin McCarthy and Mrs. Campbell-Præd, in their Town and Country Library.

— Almost the only new English poet who has won a way into American magazines in the past two or three years is Mrs. Graham R. Tomson, a collection of whose verse is about to be issued by Longmans, Green, & Co., almost at the same time that they publish Col. Higginson's poems. Mrs. Tomson's book is called "The Bird-Bride, a Volume of Ballads and Sonnets." The title "ballad" is of interest to Americans, in that it is an Eskimo legend.

— In the May issue of *The Chautauquan*, Professor J. A. Harrison of Washington and Lee University discusses "Physical Culture in Ancient Greece;" Thomas D. Seymour of Yale University writes on "Demosthenes," the eighth in the series of Greek biographical sketches; Russell Sturgis has a paper on "The Archæ-

ologist in Greece;" the Rev. J. G. Wood, the eminent English naturalist, gives the first of a two-part paper on "Odd Fishes;" Charles Barnard writes of "The Social and Economic Effects of Railroads;" Helen Campbell discusses "The Child and the Community;" "Internal Improvements" is the subject of an article by Franklin H. Giddings of Bryn Mawr College; John Burroughs writes on "Lovers of Nature;" Professor Charles J. Little of Syracuse University considers "The Paris Mob and its Achievements;" an article on "Queer Uses of Words" is from the pen of Rebecca Hart; a sketch of the Russian general, Loris-Melikof, is translated from the *Revue des Deux Mondes*; Dr. H. C. Adams of Michigan University explains the nature and use of "National Bank Notes;" and Charles Frederick Holder closes the list of contributed articles with an account of "The Early Californians."

LETTERS TO THE EDITOR.

* * *Correspondents are requested to be as brief as possible. The writer's name is in all cases required as proof of good faith.

The editor will be glad to publish any queries consonant with the character of the journal.

Twenty copies of the number containing his communication will be furnished free to any correspondent on request.

The Robinson Anemometer.

IN concluding my share in the discussion of this question, I wish to show that it looks now as though Professor Marvin and I have been considering the same resultant effect in the anemometer problem, but from different standpoints. If we place an anemometer on a whirler in a free wind, it is easy to see that the wind must have, relatively, a constant effect in all portions of the rotation. If the wind is double the velocity of the whirler, the resultant effect will be due two-thirds to it and one-third to the whirler; if the two are equal, each will produce half the effect; and so on. This effect has an actual continued increase during half a rotation, and an equivalent diminution during the remaining half: therefore it seems plain that the momentum acquired by the cups during half the rotation of the whirler would be balanced by that lost during the other half.

Viewed from the standpoint of the free wind effect, however, we see an entirely different condition. In computing the anemometer factor, it has been customary to regard the motion of the whirler as entering in its entirety in every rotation, and the whole resultant effect of both whirler and wind on the anemometer has been combined with that. In consequence the total effect differs with each relative motion of whirler and wind. For example: if the wind is double the whirler velocity, there is an increase above the motion due to the whirler during the whole of its rotation, and a total increase in the effect, due to the wind, of about 100 per cent; if the two are equal, there is an increase for two-thirds of the whirler rotation, with an increase of over 25 per cent in the effect due to the wind; if the wind is half the whirler, the increase continues through about 59 per cent of the rotation, with an increase in the resultant of 10 per cent; and so on. If we add to this the effect of whirls in the air, the low results found in England seem to be accounted for.

It seems to be pretty well proved that heavy cups, from their momentum, do not run ahead of lighter cups in an intermittent wind; and even if they did, their resultant motion would not be increased on a whirler. There is good evidence, that, at least at a low velocity of the whirler, the direct effect of the free wind accounts for the very low anemometer factor found therein.

H. A. HAZEN.

Washington, D.C., April 15.

Surveys, their Kinds and Purposes.

WILL you kindly permit me space to criticise some of the conclusions reached by Mr. Marcus Baker, in the paper on "Surveys, their Kinds and Purposes," published in your issue of Nov. 30, 1888? The classification of surveying work is becoming more important every day, in view of the greater interest the States are

taking in the preparation of working maps of their territories, and the extensive surveys that have been authorized by the general government. Any thing, therefore, that will tend to bring about a better understanding of general terms should be hailed as a step in the right direction. Mr. Baker presents one view of the subject in a forcible manner, but it seems to me far from satisfactory.

The title of the paper fairly justifies the impression that the author intended to classify surveys which result from the practical application of the science and art of surveying; and, indeed, the subjects enumerated in the second and third of his "great divisions" bear out the inference. In the "first division," however, which includes all surveys for general purposes in its broad scope, he fails to mention many kinds which he might include, unless he is willing to restrict the word "survey" to work related to what the Germans would call *Vermessungs-Kunde*. Why include geological and agricultural surveys, and omit statistical, ornithological, and botanical surveys, not to mention many others?

The geologist doubtless needs maps on which to exhibit some of the results of his geological explorations, but the science of geology and that of surveying can hardly be related by merely putting the words in juxtaposition. It must ever remain a thankless task to classify heterogeneous subjects whose kinship is due merely to the use of the word "survey" in a metaphorical or general sense, rather than in the precise and technical one in which it is used when applied to the second and third divisions.

But Mr. Baker does not uphold the classification he has offered any further than to maintain that it will answer his purpose quite as well as many others that could be made; and we might therefore let it pass had he not advanced a principle for its construction that would tend to endless difficulties should it be universally adopted.

That "surveys must be of various kinds, because they are made to serve various purposes: a classification of kinds is, then, a classification by purposes,"—I believe to be a fundamental error. Nor is it strengthened by the grouping into three great divisions,— "information," "boundary," and "improvement" surveys; or, as he expresses their equivalents, "general," "jurisdictional," and "construction" purposes; or the subsequent definition that "the general study of the earth is the object and purpose of information surveys." Strictly speaking, all surveys are for information, and therefore the three great divisions could with propriety be consolidated into one. It is only through the definition, "the study of the earth," that the "divisions" are plausible. Admit that a survey may be useful for many purposes, and they are no longer tenable. There are but few surveys of mensuration that have been instituted primarily for the purpose of acquiring information for "the study of the earth," while all contribute to this end. For many years past, since the art of surveying has been recognized as a science, surveys have been classed under designations that seem to me to admit of little improvement,— from "geodesy" we have "geodetic" (measurement of the earth); from "topography," "topographic" (measurement of the land areas); and from "hydrography," "hydrographic" (the water areas). All surveys of mensuration are included in these three, either directly or in combination with one another. A geodetic survey has a single purpose primarily, but it may also be the basis for all other surveys. Topographic and hydrographic surveys may be executed independently of the geodetic, or may be based upon it. They may also be conducted on the principle of the Coast Survey, based upon a triangulation not always of geodetic value. Such a work has frequently been designated a "trigonometrical survey," implying areas of land, water, or both, in which the distances and directions are controlled by a triangulation.

There is a second class of surveys that consist largely of explorations, such as geological, agricultural, botanical, magnetic, etc., that require surveys of mensuration in greater or less detail for their comprehensive elucidation. But the mensuration does not give them their value; and it is desirable, therefore, that they should not be classed with work of that description. Aside from the fact that they are so comprehensive, a classification by themselves seems essential.

Surveys of mensuration may be divided into many subordinate classes, but they do not necessarily lose their general distinctive char-

acter in the process of division. Surveys for railroads, canals, or any works of construction on the land, are still topographic surveys. For many works of construction, the surveys must be of the most detailed character, and their execution is topographic work of the highest order. A great deal of confusion has undoubtedly arisen from the inadvertent use of the word "topography," restricting it to a description of the irregularities or relief of the earth's surface. Originally it was used to describe the artificial or cultural features only; but as the science of surveying was developed, and the relief became an important feature of topographic work, by almost universal practice, it was defined to include both artificial and natural features. To restrict its meaning now to the relief features will drive out the only word we have that represents the "face of the earth and all there is upon it," and gives us nothing in its place. Would it not be better to adhere to "relief of the topography," or "orography," or even coin a new word, than part with "topography" in its comprehensive sense?

It may be, as Mr. Baker states, that the object and purpose of topographical surveys is the production of topographical maps; but it is far from conclusive when he defines a topographical map as one "with an accuracy and detail sufficient for all general purposes," and that such a map "is not made for any one specific purpose, any more than a jack-knife is." "General purposes" is a very catching expression, but very hard to define in a topographic sense; it is probably a near kin to "ordinary" in the classification, but surely neither of them should be acceptable in defining or classifying an exact science. If the comprehensive meaning of "topography" is the true one, the topographic survey will serve all purposes in which topography may have a value, whether they are of the alleged "general" nature, or specific. But such surveys are necessarily expensive, and they are only undertaken by those nations that have use for such detailed results. Mr. Baker produces a table showing the scale of publication adopted for the general maps of European countries, leaving the inference that the surveys are made with this scale of publication in view. Such is the case in some instances; but the exceptions go to prove the rule, that, where a knowledge of all the topography is valuable, the working scales are three to six times larger than the general publication scales. This is substantial evidence that the detailed knowledge of the topography has a far greater economic value than the general knowledge. If it were not so, the great expense of the large-scale surveys would not be incurred.

In the following table I have added to Mr. Baker's figures the scales on which the surveys are first mapped.

	Publication Scales.	Scale of Surveys.
India.....	1 : 253440	{ 1 : 63360 1 : 15840 1 : 3960
Russia.....	1 : 126000	1 : 31000
Germany.....	1 : 100000	1 : 5000 to 1 : 25000
Norway.....	1 : 100000	1 : 25000 " 1 : 100000
Portugal.....	1 : 100000	1 : 50000 and larger
France.....	1 : 80000	1 : 10000 " 1 : 40000
Austria Hungary.....	1 : 75000	1 : 25000 " 1 : 28800
England.....	1 : 63360	1 : 2500 " 1 : 10560
Sweden.....	1 : 50000 to 1 : 100000	1 : 10000 " 1 : 50000
Italy.....	1 : 50000	1 : 10000 to 1 : 50000
Spain.....	1 : 50000	Field notes
Denmark.....	{ 1 : 40000 1 : 80000	1 : 20000
Switzerland.....	{ 1 : 25000 1 : 50000	1 : 25000 and 1 : 50000
Belgium.....	{ 1 : 20000 1 : 40000	1 : 20000

It is more instructive as now compiled, and shows among other things that the scale of a map depends upon the character of the subject, as well as the purpose for which it is constructed; and we thus see how a complete topographic survey will furnish maps for

any purpose, and that, as the scale of the original surveys is reduced, their value becomes less. In England the large scales have superseded the small scales, and even in India there is no scale for the surveys smaller than one inch to the mile. In France, as recently as 1878, surveys of the whole country, to be published on 1:10000, were recommended by a commission specially organized to consider the subject. In nearly all these countries it will be observed that surveys are plotted on scales about three inches to the mile, and some on scales much greater.

A map is understandingly designated by the purpose for which it was compiled, as each purpose may require the representation of different features and greater emphasis on special features; and if referring to the land, they are topographical maps, as they represent topographic features, though perhaps not all of them.

I believe Mr. Baker is also in error in designating hydrographic and physical surveys under the head of nautical surveys. The latter class of work has its own meaning, is understood as being less rigorous than measurements upon the land, as, indeed, must be the case from the nature of the operations and the methods necessarily employed in their execution. It is more nearly a branch of hydrographic surveying, and is usually classed there or as exploration, although it may embrace a margin of land in the survey. The maps produced by this method are generally intended for nautical purposes, and its use is confined almost exclusively to the ocean and definition of the coast-lines.

Physical hydrography develops forces as well as forms: it seeks a cause for an effect, and thus perfects a hydrographic survey. In the same sense a geological survey would be the perfection of the topographic. But while similar in conclusion, they are different in method; for in the hydrography we measure the forces now at work, while in geology we must deduce them, and can but estimate their power. I would therefore reverse Mr. Baker's classification, and designate nautical surveys and physical hydrography as subdivisions of hydrography.

The preceding discussion relates to the determination of facts as they now exist. But surveying as generally understood embraces also the opposite of this, or the marking on the ground of lines previously agreed upon; which marks may in turn become facts in future surveys. This class of work is generally connected with engineering operations; but it is also the character of boundary work, and the usual operations in mining surveys. In the case of a railroad or canal, it consists in locating upon the ground the line that has been determined upon, with its cuts, embankments, etc., as marked upon the drawings made from the topographical survey; in the case of a boundary, to locate a point or line on a given meridian or parallel, or to run a line in a certain direction from a given point, or both; and in mining, the location of a new shaft or heading, or any of the many operations connected with the engineering work of a mine. Mr. Baker has grouped this class of work into two divisions, — "boundary" and "construction" surveys. But, it will be observed, the work is all of the same character, and might therefore with perfect propriety be grouped in one class, under the term already well understood by surveyors and engineers, — "location."

We thus have three divisions — mensuration, exploration, and location — in which may be grouped different classes of work according to the nature of the operation, and which would usually be subdivided by the purpose for which the survey was made, or the method upon which it was conducted, and sometimes a combination of both. These subdivisions will readily suggest themselves, but would make too long a list for insertion.

In conclusion, permit me to add a few words on what Mr. Baker declares "a well-recognized principle, especially among engineers, that of two maps, or works of any kind, made for the same purpose, and serving that purpose equally well, that one is best which is cheapest." This implies, that, of two things exactly alike, the one that costs the least is the best. If they are alike, the price cannot affect their utility for the purpose for which they were designed, though one cost ten times the other. The cheapest would probably be most satisfactory to those who had to pay the bills; but, if both were the same price, there could be no choice for any reason. We may readily conceive, however, that if bids were offered to make two maps or works of any kind, that should serve a speci-

fied purpose equally well, the cheapest would be most favorably considered in the majority of cases; but, if the work was to be executed by two bodies of men of like skill and experience, we should have to conclude that one party was seeking an unusual profit, or that the other did not intend to live up to the contract, for it is inconceivable that two bodies of intelligent men, honest and experienced in their trade or profession, would execute a similar work with any great variation in the cost.

HERBERT G. OGDEN.

Washington, D.C., April 9.

English Examinations.

A SHORT time since, the public was greatly amused at a book containing a collection of ludicrous mistakes made by children in their examination-papers. Much merriment was excited by these poor little attempts at wisdom, and doubtless not a few persons laughed at the blunders of their own children, not perhaps understanding that some of this stupidity might have been inherited. Nor did the teachers who culled these blighted flowers seem to realize that many a thoughtful reader might be in doubt as to whether such evidence was intended to prove the incapacity of the children to learn, or the inability of the teachers to teach. Then human nature asserted itself in a cry of derision at the whole system of school education, and this was as manifestly uncalled for as the first outburst of cachinnation.

The method of examining college and university students is another serious matter that demands our attention. At the moment, the main agitation is in England. The recent expressions of opinion by eminent Englishmen as to the results and tendencies of the examination system there in vogue are appalling. There can be no doubt that the matter is one of grave importance. The examination system of England compels men to cram, — to become mere memorizers of facts, to substitute a hasty and temporary knowledge of these for reasoning, and to become learners of other men's ideas and discoveries to the exclusion of the ability to discover facts and create ideas for themselves. The result of this form of education is to make absorbers and not producers of knowledge, — as Shakspeare says,

"Small honor continual plodders ever won,
Save bare authority from others' books."

Such a condition is one of intellectual serfdom. The individual becomes dependent on others for advance in knowledge. His power to originate is not developed. He becomes a mere book, except that he costs more than a book, and is worth far less, less convenient to handle, less complete, and generally of far less use, — a kind of an old edition, lacking many pages, index, and author's name, badly bound, and full of omissions and errors.

The effects of the English examination system are readily seen in the many "cram" books that are published in that country, and which lack system and didactic worth. Most of them are professedly helps in preparing for examinations. The virus is also at work in this country, and earnest educators should lose no time in resisting its inroads. The result of this agitation is an outcry of the thoughtless against examinations of any kind. This, I think, is wrong. That bad effects are produced by certain kinds of examinations is very true; but that all examinations have therefore an evil tendency, I emphatically deny. So far, the consideration has not extended as thoroughly as it should to the nature of the examination from a didactic standpoint. That a certain class of examinations yield bad results, proves, not that all kinds of examinations are worthless, but that that particular kind of examination does not give satisfactory results. That may be because the examination is wrong in principle, because it is not the one called for by the work done, because it is imperfect, because it does not really show that the student knows any thing about the subject, nor because the examiner does not know how to examine. I venture to say that a considerable number of the teachers in colleges and universities, although men of undoubted learning and ability, and in many instances investigators of acknowledged reputation, do not pay much attention to the pedagogical side of their subjects, and, least of all, do not attempt to make a study of the principles and methods of examining. The science and art of examining are

really most important branches of pedagogy. Good examiners are rare, even among a body of eminently successful teachers.

Varied as may be the questions, ingenious and cunning as may be the side-issues woven in and easily overlooked, skilful as may be the attempts to trip the student, hidden as may be the pitfalls and snares, (and how quickly does an old student recognize them!) the average examination-paper calls for but little more on the part of the student than an accurate memory of facts, and some little ingenuity in twisting them. By it may be ascertained the nature and amount of facts that the student has gained. By it cannot be ascertained the increase in intellectual power of the student, his ability to apply these facts, the nature of the effect of the particular study upon his intellect, his ability to proceed independently in the study of the subject, the development of original thought in him, his interest in the subject, his perception of the value of the subject to him, or whether he has been imbued with the true spirit of that subject. Has he received "sacks full of dry leaves," or has he seen "the living, growing tree"? Has the study been presented to him as the mortal, short-lived body, or the immortal, upward-soaring soul? The student tells about the odor, color, taste, and form of substances he has never seen, and of physical phenomena he has never observed. He quotes from books he has not read, cites facts which he cannot establish, defends theories in which he does not believe, and proves to the satisfaction of the examiner statements which he doubts at heart. If the examination does not show more than a memorized knowledge of facts, it amounts to the old *a b, ab; b c, bc*; it is a waste of time and energy; it's a hypocritical farce. The young student feels it to be one, and the older student and the teacher know that it is one.

Numerous remedies have been prescribed, and some are certainly excellent. Examining committees are a step in the right direction. If each member questions the student, the result will be that he will soon show what real progress he has made in the subject, and also how well he has been taught. But these committees, while good in theory, rarely carry out their work with much success, for a natural delicacy is felt in pushing hard the student of a colleague; and the majority of the committee-men have, as a rule, quite enough to do in examining their own classes. A bright, keen man of business often makes a good examiner. He does not know much about the subject, and really wants information. To enlighten such a man, and satisfy his inquisitiveness, the student has to assume the part of teacher, and soon shows if he really knows any thing about the subject beyond a mere parrot-like repetition of disconnected facts. Such an examination, however, is always incomplete, and often too long. Neither can such an examiner go through a whole class.

As in all other matters, to make examinations of value, the subject must be investigated and the principles found out. We must know what objects are to be attained, and then we must follow, as best we can, not an empirical routine, but a philosophical procedure; not like professors in the University of Laputa, but remembering that we live in the nineteenth century.

The mind acts successively in three ways; viz., by observation, comparison (judgment), reason. These are broad divisions, and may of course be subdivided, but it would be beyond the scope of this paper to go into the details of classification. Having obtained facts by observation (and I include here not alone the physical and chemical properties of unorganized and organized matter, but statements of events, and of subjective data, etc., such as may be obtained by reading), the mind compares the mental images so gained, and perceives wherein they resemble each other and wherein they differ. The next step is reasoning,—inductive when the step is from the particular to the general, and deductive when it is from the general to the particular. These four actions of the mind should always be tested in an examination, that it may show what effect the study of the subject has had on these four typical mental processes, and how well the mind has been trained to act in this fourfold way by the study of the subject.

A student may tell us all about Napoleon and Washington as glibly as if he were reading from a book. But let him be asked wherein these two men resembled each other, and wherein they differed from each other; and the glibness disappears like a flash; for the mind must now apply its facts, compare the images, and

note similarities and differences. The student begs for time to think,—a sad reflection on his previous answers. I will also include memory as a faculty of the mind. It should always be tested by an examination, but it is a very difficult matter to say just what value is to be placed on it. It is a treacherous and elusive faculty. It may be temporarily active, yet in the main torpid. It may be slow, yet lasting. Its absence is a fault, its presence is a danger. It has many forms, and plays many a deceitful *rôle*. While memory is the antecedent necessity of thought, it is still a subservient faculty. It is the useful slave, but a tyrant when master. I would make it work to its full limit, yet not honor it with medals. It is my tool, my library, my sword, my medicine, but it is not *I*. The wise teacher and examiner know well how to bring out its full value, and yet not to be led astray by its dazzle. Readiness of perception should also be taken into account, but this is still more difficult to value than memory. Men reach their objective aims in different ways, some quickly, some slowly. The important point is to be sure that they really do attain them.

The difficulty with the examinations in vogue in England, to judge from the complaints recently published, is that they fall too entirely under the first head. They test the students' powers of observation alone, and allow the substitution of memorizing for thinking. While they fall under observation, these examinations do not at all test or train the students' real or full powers of observation. In physical science, for instance, the school-knowledge of the properties of matter learned from books is not to be compared with the worth of the same knowledge gained by actual experiment on the part of the student. No amount of "cram" can ever teach a student the possible differences and similarities between the images that his memorizing of facts has stamped on his mind with more or less vividness and durability. The skilled examiner can ring changes on them without end. Nor can "cram" help to any extent in reasoning. Inductions and deductions can be ground out in an endless stream, even by the average examiner; but the experienced questioner, studying the mind before him, as one dissects some delicate organism, tests its working, examines its products, and notes its behavior under varying conditions, forming a fair opinion as to what it is intended to do, and how well it may be expected to do it. Nor need any two examinations ever be alike; assuming, of course, that the teacher is himself a real teacher, and not a mere animated phonograph.

Such examinations be so conducted as to test the mind in the way indicated, there would be of course a great turmoil, for hundreds of students would fail to pass. As the blame for the failure of the student to understand what he studies is usually, and to a certain extent with justice, thrown on the teachers, there would be another wild outcry on their part. All of this agitation would result, however, in what is really demanded,—a form of examination that should show the condition and working of the student's mind as affected by each particular subject, and that should also demonstrate the ability of the teacher, not only to impart information, but to develop minds by means of his particular subject. It will require great courage on the part of teachers to give examinations that shall show whether the students really know any thing about the subjects of their studies. It will be difficult to assign marks to such examinations that shall be entirely satisfactory or exact; but the education of the student in facts and principles, the development of his mind by them, and his ability to observe for himself and to use his knowledge in the production of new knowledge, will be attained. These, and not the representation of mind-power by figures, when no unit of mind-power is known, are the real objects of education; for the ideal man of to-day is not he who simply acquires knowledge, but he who makes knowledge. Production, not absorption, is the standard by which men are to be judged. Knowledge alone is not power, it is the ability to use knowledge that constitutes power.

Examining, or testing the condition and action of the mind, is a subject of great pedagogical importance. It certainly seems evident that the present agitation about examinations will end in proving, not that examinations are of no value, but that many examiners do not yet fully understand the facts, principles, and methods of examinatory science.

PETER T. AUSTEN.

New Brunswick, N. J., April 13.

GUARANTY INVESTMENT COMPANY

CAPITAL \$250,000.

Hon. ALBERT H. HORTON (Chief Justice, Kansas Supreme Court), Topeka, Kan., Pres't.

7% Guaranteed Farm Mortgages 7%

The Company calls the special attention of Investors to the following points :

- I. All loans guaranteed and interest payable semi-annually at the Importers' & Traders' National Bank, New York.
- II. Unusual fulness of information, not only about the security itself, but about the general development of the section where the farm is located.
- III. An examination each year of the general business of the Company and the Mortgages themselves by a COMMITTEE OF INVESTORS sent for the purpose.
- IV. Many hundred Mortgages taken and NOT A SINGLE FORECLOSURE.
- V. Exhibitions in New York at frequent intervals, of Kansas and Nebraska Farm Products. The Exhibition at the American Institute in the fall of 1888, received the *HIGHEST AWARD* of superiority.
- VI. Monthly Bulletins giving full information about all Mortgages offered for sale.

Address for Monthly Bulletin and Investors' Committee Report for 1888,

HENRY A. RILEY, General Eastern Manager, 191 Broadway, N.Y.

GEOLOGY AT A GLANCE.

Ives Strata Map of part of the United States of America and Canada,

In which the Architecture of the Earth's Crust is Graphically Exhibited, Illustrating Fundamental Facts alike of

STRUCTURAL GEOLOGY AND PHYSICAL GEOGRAPHY.

The Strata Map is a device for the more efficient teaching of Physical Geography and Elementary Geology in Schools. It consists of a series of Ten Superimposed Maps, of different colors, representing the several geological formations of the district, enclosed in a glazed frame, the whole hinged to ad-

mit of examination in detail. By its means *superposition, denudation, and outcrop* of strata are graphically exhibited, with the phenomena of *escarpments, outliers, salters, dip, strike, conformability, &c.*, and the Cards may be bent to show *synclinal or anticlinal* folds.

OPINIONS OF EMINENT GEOLOGISTS.

Yale University. Professor James D. Dana.
 "Well fitted for the use of instruction in the science."
 Professor Addison E. Verrill.
 "It will be of very great advantage in the teaching of geology."
 Harvard University. Professor N. S. Shaler.
 "An extremely useful adjunct to our means of illustration."
 Johns Hopkins University. President D. C. Gilman.
 "Wherever American geology is taught your map should be a part of the apparatus."
 Pennsylvania University. Professor Geo. A. Koenig.
 "The map will be of special use in schools, which can only devote a short time to the study of Geology."
 Michigan University. Professor Alexander Winchell.
 "It seems to me that the device will commend the study of Geology to many persons who might otherwise regard the subject as difficult and uninteresting. The work prepared by Mr. Ives ought to be used extensively in American schools."
 Cornell University. Professor H. Shaler Williams.
 "A valuable aid to teachers of geology as a means of graphically representing the grand facts of stratigraphy in the Eastern United States."
 Columbia College, New York. Professor J. S. Newberry.
 "A valuable aid in teaching geology, giving as it does to the student a clear idea of the superposition of the different geological systems at a glance."
 Dartmouth College, Hanover, N. H. Professor C. H. Hitchcock.
 "Am satisfied that its use will greatly assist students to understand the geological structure of the country."

Academy of Natural Sciences of Philadelphia. Professor Angelo Heilprin.
 "The representation of Strata, as imposed one upon the other, by means of cardboard is certainly a good plan, for apart from rendering more intelligible the general expressions of the Map, it permits of ready alteration and the possibility of constantly bringing the map up to date, in other words to make it conform to more recent discoveries."
 Boston Society of Natural History. Professor Alpheus Hyatt.
 "Your map representing superposition and the various phenomena of geological science, so far as the distribution of rocks on this continent is concerned, has greatly interested me. I think that in the hands of a good teacher it would prove an efficient and useful adjunct in the teaching of geology."
 American Museum of Natural History. Professor R. P. Whitfield.
 "In the direction of a want long felt by Teachers of Geology and will undoubtedly be appreciated by them as well as by the student."
 U. S. Geological Survey. Major J. W. Powell, Director.
 "After examination I am able to state that the work has been executed with care and fidelity, and I believe it will be a valuable aid to teachers."
 New York State Survey. Professor James Hall, State Geologist.
 "I believe that maps constructed upon this method would be extremely useful in the hands of competent teachers."
 Pennsylvania Survey. Professor J. P. Lesley, State Geologist.
 "A piece of new and useful apparatus for teaching Geology, by representing to the eye of the student the areas of superimposed formations. I cordially recommend it to teachers and students."
 New Jersey Survey. Professor Geo. H. Cook, State Geologist.
 "It is very neatly done and must prove a great help to intelligent teaching and studying of Geological Science."

SIZE 30x24 INCHES. PRICE \$17.50.

PUBLISHED AT THE OFFICE OF "SCIENCE," 47 LAFAYETTE PLACE, NEW YORK, N. Y.

Dry Goods Openings

are now all the style. Small dealers make a great ado about the opening and display of each season's novelties. It belongs to the metropolis of the nation and to the great business houses on its broad streets to have a continuous series of openings the year round. Of the limited number of truly great dry goods establishments in New York, Messrs. James McCreery & Co., in the matter of original exhibits combining novelty, originality, and exclusive design, lead all the rest. This enterprising firm have a well earned reputation for integrity in their business dealings, remarkable quality in the goods offered for sale, and moderation in price. Their constantly recurring advertisements in this paper are truthfully written and their representations can be depended upon.

Schools.

CONNECTICUT, NEW HAVEN, MRS. CADY'S SCHOOL FOR YOUNG LADIES. Prepares for Smith and Wellesley, and admits to Vassar by Certificate. Circulars. Early application necessary.

NEW JERSEY, PLAINFIELD. THE CHESTNUTS.—Parents with daughters to educate, or orphan girls with companion, may find a comfortable home, with school instruction by applying to Miss E. E. Kenyon.

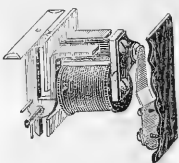

A DROP IN THE PRICE OF

GRAVITY DROP ANNUNCIATORS.

DON'T FORGET THE

DUST-PROOF BELLS.

HAZAZER & STANLEY, 32 Frankfort Street, N. Y.

Any one who will have the following blank filled out by a responsible Newsdealer, and mailed to us, will be allowed a three months' subscription to Science.

N. D. C. HODGES, 47 LAFAYETTE PLACE, NEW YORK.

1889.

To the News Company.

You may add to my regular order five copies of SCIENCE each week (returnable).

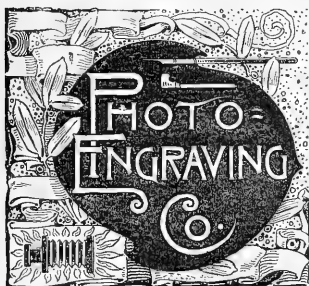

JOHN HASTINGS = Pres't. A-R-HART = Gen'l Manager. JOS = TRIPP = V.Pres't.

ENGRAVING FOR ALL ILLUSTRATIVE AND ADVERTISING PURPOSES

BRANCH AT 728 CHESTNUT ST. PHILADELPHIA, PA.

67-71 PARK PLACE NEW YORK.



GOOD NEWS TO LADIES.

Greatest inducements ever offered. Now's your time to get up orders for our celebrated Tea and Coffee, and secure a beautiful Gold Band or Moss Rose China Tea Set, Dinner Set, or Webster's Dictionary. For full particulars address THE GREAT AMERICAN TEA CO. P. O. Box 369, 81 and 83 Vesey St., New York.

16 PAGES. THREE 16 PAGES.

Hundred Thousand new subscribers for The Family Journal and Ladies' Companion wanted. It is the most interesting and instructive paper ever issued. Subscribers will receive during the coming twelve

MONTHS

novels written by American Authors, complete in each three numbers. The story of popular works of fiction will be related by a novel reader, the most interesting and unique feature ever introduced in any publication, giving the substance of popular and standard books by famous writers in a space easily read by the busiest people. We have engaged

FOR

this work a widely known and popular writer. Comments on Current Events, Fashions, New and Original Ideas and Designs for Ladies' Fashion Work and Household Decoration, get from Correspondents and their Answers. The colleges and seminaries of the United States will be treated one each month in an illustrated article, showing the particular advantage of each, cost of attendance, etc. Invaluable to parents having sons or daughters whom they desire should receive the advantages of a higher education than the ordinary school affords. Articles on Painting and Drawing, giving home instruction by a well-known artist. A trial subscription of this elegant paper will be sent to any address, three months for

TEN CENTS.

Liberal pay for literary work adapted to our columns, and for new and original drawings, designs and ideas on any subject which we can use. Premium List the most complete in the world. We offer inducements to club raisers and agents approached by no other publishing house. The celebrated Gilbert Out Waist Linings, which we send post paid to any one sending us two yearly subscribers at 10 cents each is alone worth 75 cents. Sent to any address, postpaid one year, 50 cents; six months, 25 cents, and a three months' trial subscription for only 10 cents.

TRY IT! TRY IT! TRY IT! and you will become a permanent reader. Address:

John L. Douglass, Publisher, 322 Broadway, N. Y.

SPECIAL Importation Sale

The following unusual value in short ends and Special purchases are worthy of your attention

- \$50 Suits |||
\$45 Suits ||| AT \$35
\$42 Suits |||
\$40 Suits |||
\$14 Trousers |||
\$12 Trousers ||| AT \$7
\$10 Trousers |||
\$9 Trousers |||

People who appreciate FINE Clothing at unusual moneys worth will please notice the above.

E. O. THOMPSON, Fine Merchant Tailoring, 245 BROADWAY.

Extract of Letter from Merchant Tailor:

"I am informed that your knowledge of cutting is far ahead of all others - could kind words and a commission induce you to teach me your system?"

C. & C. ELECTRIC MOTOR COMPANY.

Electric Motors
FOR
Arc and Incandescent Circuits, Most Economical Motor on the Market.
Regulation Perfect.
Motors Designed for all Power Purposes.

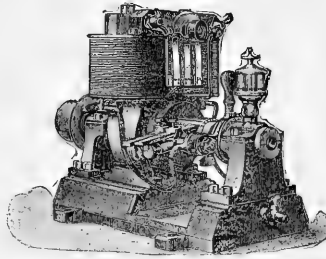

OFFICE and MANUFACTORY:
402 and 404 Greenwich Street, New York City.
New England Office, 19 Pearl St., Boston.
Philadelphia Office, 301 Arch St.
Western Office, 139-141 Adams Street Chicago.
Southern Office, 25 Carondelet Street, New Orleans.

THE American Bell Telephone COMPANY.

95 MILK ST., BOSTON, MASS.

This Company owns the Letters Patent granted to Alexander Graham Bell, March 7th, 1876, No. 174,465, and January 30, 1877, No. 186,787.
The Transmission of Speech by all known forms of ELECTRIC SPEAKING TELEPHONES infringes the right secured to this Company by the above patents, and renders each individual user of telephones, not furnished by it or its licensees, responsible for such unlawful use, and all the consequences thereof and liable to suit therefor.

ESTERBROOK'S STEEL PENS.
OF SUPERIOR AND STANDARD QUALITY.
Leading Nos.: 048, 14, 130, 135, 239, 333
For Sale by all Stationers.
THE ESTERBROOK STEEL PEN CO.,
Works: Camden, N. J. 26 John St., New York.

Old and Rare Books.
A. S. CLARK, Bookseller,
34 PARK ROW, NEW YORK CITY.
A Gleaner in the By-ways of Literature. Results of Gleaning found in Catalogues issued from time to time.
CATALOGUE NO. 27 NOW READY.
BACK NUMBERS and complete sets of leading Magazines. Rates low. AM. MAG. EXCHANGE, Schoharie, N. Y.
H. WILLIAMS,
Dealer in Old Magazines, Reviews, &c. Scientific periodicals a specialty. 39 Macdougall St., N. Y.

Scientific Apparatus.

J. GRUNOW,
621 Sixth Avenue, New York.
Established 1852.
MAKER OF
Microscope Stands, Oil Immersion Objectives and Abbe Condensers for Bacterial and Histological work, of Objectives, Camera Lucida and other accessory apparatus.

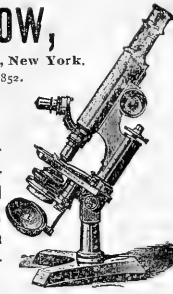

IMPROVED OIL LIGHT MAGIC LANTERNS.
Also Lime and Electric Light Apparatus, and mechanical, plain, and fine colored views.
J. B. COLT & CO., Manufacturers,
No. 16 BEEKMAN STREET, NEW YORK.

MAGIC LANTERNS Stereopticons and the Best Views for Public, Church, Home, and Scientific Exhibitions. Best apparatus, new views. Largest stock. Reduced prices. 24 Years' Practical Experience. Illus. Catalogue Free.
GEO. H. PIERCE,
136 S. Eleventh St., Philadelphia, Pa

ELECTRICAL TESTING BUREAU,
Johns Hopkins University, Baltimore, Md.
Resistance Coils and Boxes Compared.
Am meters and Volt meters calibrated.
Condensers standardized.
Primary and Secondary Batteries Tested.
Efficiency of Dynamos and Motors Determined.
Insulation of Cables and Wires Tested.
Etc., Etc.
Circulars describing Methods Used, Prices, Etc., sent on Application.
Address as above.

MORRIS EARLE & CO.
SUCCESSORS TO
R. & J. BECK,
1016 Chestnut Street Phila
Microscopes and all Accessories and Apparatus. Photographic and Photo-Micrographic Apparatus and Outfits.
Spectacles, Eye Glasses, Opera and Marine Glasses, etc.
Illustrated Price List mailed free to any address. Mention SCIENCE in corresponding with us.



E. & H. T. ANTHONY & CO.
591 Broadway, N. Y.
Manufacturers and Importers of
PHOTOGRAPHIC INSTRUMENTS,
Apparatus and Supplies of every description. Sole proprietors of the Patent Detective, Fairy, Novel, and Bicycle Cameras, and the Celebrated Stanley Dry Plates.
Amateur Outfits in great variety, from \$5.00 upward.
Send for Catalogue or call and examine. ²⁵ More than 40 years established in this line of business.

A BOOK FOR THE TIMES!
NEW EDITIONS!
Laidlaw's Constitution of the United States and the Declaration of Independence, in English, French, and German, with notes. Sold by all booksellers, or by the publishers, LAIDLAW BROS. AND CO., 137 W. 41st St., New York.
Second and Revised Edition, in cloth ----- 50c, postpaid.
Third Edition, in paper ----- 25c, postpaid.

R. ELLIS & CO.
BUSINESS, HOTEL AND PATENT BROKERS,
AUCTIONEERS, ETC.
No. 176 BROADWAY, N. Y.
Room 46. **New York.**
CLIENTS Advised free of charge.

The Mutual Life Insurance Company

OF NEW YORK.

RICHARD A. McCURDY, PRESIDENT.

ASSETS - - - \$126,082,153 56

The Largest and best Life Insurance Company in the World.

The New Business of the Mutual Life Insurance Company in 1888

Exceeded \$103,000,000.

Its Business shows the Greatest Comparative Gain made by any Company during the past year including

A gain in assets of.....	\$ 7,275,301 68
A gain in income of.....	3,096,010 06
A gain in new premiums of.....	2,333,406 00
A gain in surplus of.....	1,645,622 11
A gain in new business of.....	33,756,792 85
A gain of risks in force.....	54,496,251 85

The Mutual Life Insurance Company

Has Paid to Policy-holders since Organization \$272,481,839 82.

Arnold, Constable & Co.

SPRING STYLES DRESS FABRICS.

Plain and Hair-Line Batiste Cloths,
Printed Laines, Fancy Mohairs,
Cheviots, Tweeds,
for Steamer and Travelling Dress.

Checked and Striped Suitings,
Broche and Embroidered Robes,
Cashmeres d'Ecosse, Henrietta Cloths,
IN NEW COLORINGS.
FOR STREET AND EVENING WEAR

Broadway & 19th St.

New York.

IMPROVING THE MEMORY PICK

and facilitating the acquirement of knowledge by lectures and correspondence. Classes forming, "MEMORY and its Doctors," from Simonides to "Lo'sette," mailed for 10 cents.

DR. PICK, 24 Union Square, N. Y. City.

FOOD ADULTERATION

And its Detection. With photomicrographic plates and a bibliographical appendix. By J. P. Battershall. 328 pages, 8vo, cloth. Price, \$3.50. Circulars and Catalogues on application. E. & F. N. SPON,

12 Cortlandt St., New York.

PATENTS.

During April and May my fees due only on allowance if desired. Write

WM. H. BABCOCK,
513 Seventh St., Washington, D.C., P. O. Box 220.
Formerly Examiner in Patent Office.
THIRTEEN YEARS' PRACTICE.

A SEASONABLE FABRIC.

This refers to a Wash Silk, one that can be washed without the least injury to the fabric, either in appearance or color.

The lack of just such a material has long been felt, and its introduction will undoubtedly be received with satisfaction.

Wash silks are light in texture, tasteful in design and coloring, and very durable, being thus eminently adapted for Spring and Summer Wear.

We are showing exclusive styles.

JAMES McCREERY & CO.

BROADWAY AND ELEVENTH STREET,
NEW YORK.



KIMBALL'S STRAIGHT CUT CIGARETTES.

Unsurpassed in quality.
Used by people of refined taste.
Highest award at Brussels, 1888.
The finest smoking mixture of our manufacture.
Fifteen First Prize Medals.
WM. S. KIMBALL & CO.,
Rochester, N. Y.

ESTABLISHED 1859.

H. A. DREW,

Commercial Printer,
5 Clinton Place, near Broadway,
New York.

Wedding Orders, Souvenirs, Invitations, Orders of Dance, etc., etc., done in the latest and most elaborate styles, at reasonable prices.

All Favors promptly attended to.

THE CHEQUE BANK LIMITED.

ESTABLISHED IN LONDON, 1873.

CHIEF OFFICE, 4 Waterloo Place, Pall Mall, London.

TRUSTEES:

The Right Honorable JOHN BRIGHT, M.P.

The Right Honorable EARL BEAUCHAMP.

Bankers: Bank of England.

The Capital of the Bank and its Guarantee Fund of 500 is invested in Government Securities.

The Bank does not discount Notes or Bills, nor speculate, but loans its Deposits against Government Securities, thus making the Cheque Bank Cheques EQUAL TO CASH—as Bank of England Notes are.

The Cheque Bank issues Cheques singly or in books from ONE POUND upwards, for the use of Travelers, and for others remitting money to Europe, available in every town in England, Scotland, Ireland, and Wales. In every town of Europe, and all other parts of the world, Cheque Bank Cheques are accepted as Cash by all the British Government Offices.

VISITORS TO THE PARIS EXHIBITION this summer can get the Cheque Bank Cheques cashed at 50 Banking Houses in Paris.

Travelers and others holding Cheque Bank Cheques can have their mail matter addressed to them, care of the Cheque Bank, London, who will take charge of the same and forward to any address.

For Hand-Book containing List of upwards of 2000 of the principal Banking Houses throughout the World who Cash the Cheque Bank Cheques, and for all information, apply to the AGENCY.

CHEQUE BANK, Limited,

UNITED BANK BUILDING,

2 Wall St., New York.

E. J. Mathews & Co., Agents.

REFERENCES BY PERMISSION:

JNO. W. MACKAY, Esq., President Commercial Cable Company, Mackay-Bennett Cables, New York.

F. O. FRENCH, Esq., President Manhattan Trust Co., New York, and others.

KNABE

PIANOFORTES.

UNEQUALLED IN

Tone, Touch, Workmanship and Durability.

WILLIAM KNABE & CO.

NEW YORK: No. 112 Fifth Av., above 16th St.

BALTIMORE: Nos. 22 and 24 E. Baltimore St.

WASHINGTON: No. 817 Market Space, Penn. Av., near 9th St.

WHY YOU SHOULD USE

Scott's Emulsion

OF Cod Liver Oil WITH
HYPOPHOSPHITES.

It is used and endorsed by Physicians because it is the best.

It is Palatable as Milk.

It is three times as efficacious as plain Cod Liver Oil.

It is far superior to all other so-called Emulsions.

It is a perfect Emulsion, does not separate or change.

It is wonderful as a flesh producer.

It is the best remedy for Consumption, Scrofula, Bronchitis, Wasting Diseases, Chronic Coughs and Colds.

Sold by all Druggists.

SCOTT & BOWNE, Chemists, N. Y.

SCIENCE

[Entered at the Post-Office of New York, N. Y., as Second-Class Matter.]

A WEEKLY NEWSPAPER OF ALL THE ARTS AND SCIENCES.

SEVENTH YEAR.
VOL. XIII. No. 325.

NEW YORK, APRIL 26, 1889.

SINGLE COPIES, TEN CENTS.
\$3.50 PER YEAR, IN ADVANCE.

COMPOSITE PORTRAITS OF WASHINGTON.

THE statement that one of the chief applications of composite photography will be in the direction of producing more reliable portraits of representative men by combining the testimonials of individual artists, will probably be accepted by all who have followed the short but interesting career of this new invention. The

suggestion that by combining the individual conceptions of several artists, one would obtain a more reliable portrait than any of the components, was near at hand. The first such application was made by Mr. Francis Galton, who made a composite of six medallion heads of Alexander the Great, and naturally claimed for the composite the combined authority of all the artists; for it is evident, that while each artist will very likely express the general features of his subject, some peculiar idiosyncrasies of his own are apt to creep in. The composite sifts out all these common traits, and presents them strong and clear, while it reduces each artist's peculiarity to a scarcely perceptible shadow.

In this way we have recently come into possession of a new Shakespeare, for which we have to thank Mr. Walter Rogers Furness. In the case of Shakespeare the diversity amongst the several originals is strikingly evident, and thus a composite was needed to give a characteristic individual, natural face. This suggested to Mr. W. C. Taylor the application of the same process to Washington's portraits. He has grouped the several portraits into

three groups, owing to the differences of position of the portraits; and the accuracy of the work is well shown by the fact that the agreement amongst the resulting three composites is very close, while the originals show every shade of individual differences. These portraits were first published in the *Journal of the Franklin Institute*, and are given on a new and enlarged plate in this number.

The lower right-hand composite has seemed to many the happiest result, and seems likely to serve as the model for future portraits of Washington.

THE *Paper Makers' Circular* (England) says that the new epoch on which we are entering will surely be known as "the age of pulp." Beyond esparto grass, straw, and wood, few fibrous substances have as yet practically taken the place once occupied exclusively by rags; but, if we should ever exhaust the sources from which we now obtain our supplies, there will assuredly be no lack of substitutes. East Indian ramie, pine-apple fibres, bamboo, bagasse (the refuse matter from sugar-canes), peat, bracken or common fern, flags, rushes, seaweed, tan, and hop-stalks, have all been proved capable of yielding pulp. In Scot-

land hollyhock-stems have been made into paper; in Ireland the mallow, red clover, hop-vine, and yellow water-iris have been put to the same use; in Demerara good paper has been made from the plantain; in France a patent has been granted for making paper out of leaves, which have been reduced to pulp.



CONGRESS OF ELECTRICIANS AT THE PARIS EXHIBITION.

By a ministerial decree dated July 16 last, it was decided to hold an international congress of electricians at Paris during the exhibition. All the arrangements are now completed, and the congress will open on Aug. 24, and remain open eight days. The following, relative to this congress, has been issued to those likely to be interested in its work: "The International Congress of Electricians, which met at Paris in 1881, marks an important date in the history of electricity. The consecration of practical unities has had on the development of science and industry an influence the significance of which cannot be exaggerated. The extreme rapidity and facility with which the decisions of the congress were accepted, in the study and in the laboratory, demonstrate their utility. The International

AN ELECTRIC DRAWBRIDGE.

ONE of the latest applications of the electric motor which has excited much interest, not only from its novelty, but also the excellence of its operation, is that of the turning of drawbridges. This is a matter to which a good deal of attention has been given both by bridge and electrical men; but it is not until recently that the motor for this purpose has supplanted steam, and the slow, laborious method of the long lever worked by three men.

One installation, the details of which are shown in the accompanying cuts, has recently been made at Bridgeport, Conn., by the New England Electric Supply Company. The drawbridge, which is 180 feet long, 60 feet wide, and weighs 320 tons, was formerly operated by three men; but this method was found to be open to

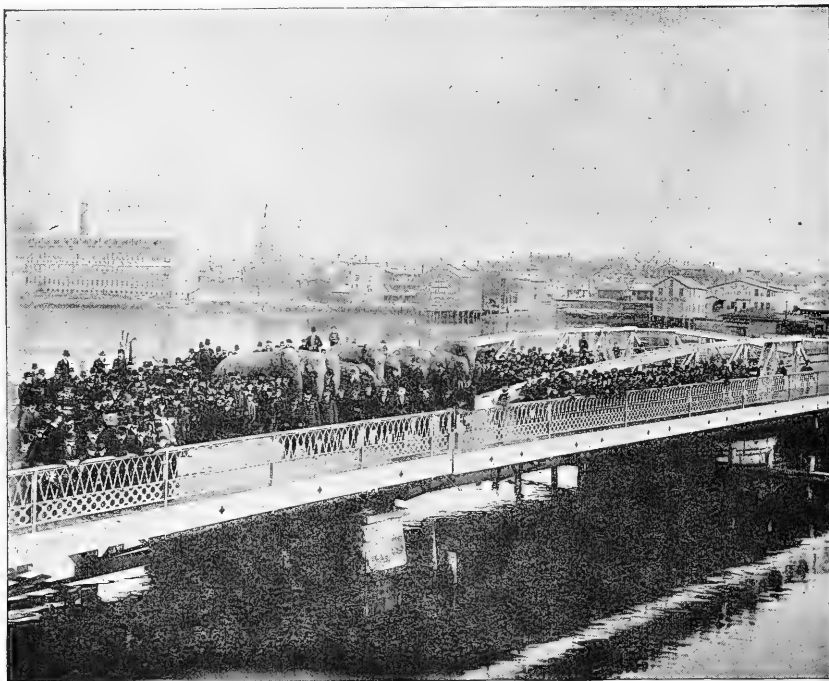

ELECTRIC DRAWBRIDGE AT BRIDGEPORT, CONN.

Exhibition of 1889 offers a natural occasion of continuing and completing the work of 1881; not that the new congress may have to treat of problems of so general and elevated an order, but many questions still remain on which an understanding, or at least an exchange of views, is desirable. In the programme which it has prepared, the organizing committee has not been pretentious enough to indicate them all, and still less to impose limits to the field of activity of the congress: it has simply wished to call attention to those which appeared to it of more general and more immediate interest. We believe we respond to the unanimous feeling of electricians in placing the following questions foremost: practical measure of electrical energy in all its forms; measure of the current in absolute value with standard of easy reproduction; electricity meters for continuous and alternating currents; practical evaluation of the lighting; definition of the constant quantities of a machine from a commercial point of view; etc. We hope that the *savants* and manufacturers who have contributed to the progress and application of electricity will readily respond to our appeal, and contribute to give this meeting the importance and authority of that which preceded it.

serious objections, and attended by considerable expense, as it necessitated the constant attendance of the men, and, under the most favorable circumstances, it took six minutes to open and close the draw, which caused a jam on both sides, and seriously interfered with the traffic.

The problem of applying electricity as a motive power has been successfully worked out to the satisfaction of both the city officials and the bridge-builders. The draw can be opened and closed in two minutes, and the expense is limited to the hiring of one man and the monthly charge of the Electric Light Company, by which a considerable saving is effected. The details of the construction are as follows:—

The current is conducted to the motor through two submarine cables, the core being equal to No. 4 B. & S. copper wire, which are protected from lightning by two Thomson-Houston lightning-arresters. The shore ends are connected to the incandescent-lighting current of the Bridgeport Electric Light Company by a double-pole switch, so that the current may be shut off at the pleasure of the draw-tender. The other ends are connected to vertical stationary posts, which are carefully insulated from the

structure, and which carry on their upper ends a pair of brushes which are in contact with two insulated copper bands attached to the circular support of the draw, and moving with it.

A rheostat is used to regulate the speed of the motor, and a

easily accessible from the road-bed. The bridge-tender has every thing under complete control, and can easily regulate the speed and the direction of rotation of the drawbridge.

The motive power is furnished by a $7\frac{1}{2}$ -horse-power Thomson-

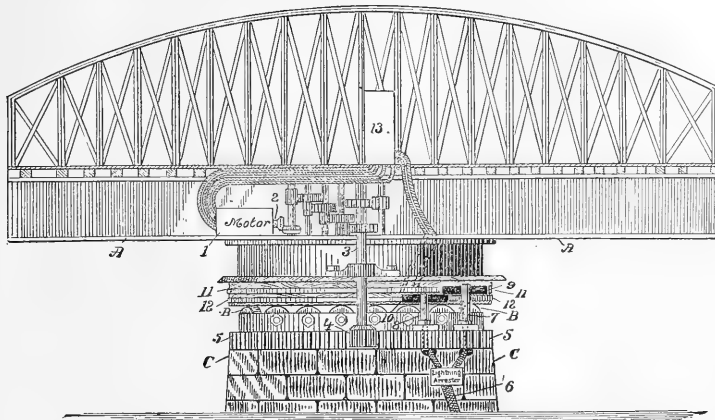

ELECTRIC DRAWBRIDGE ELEVATION.

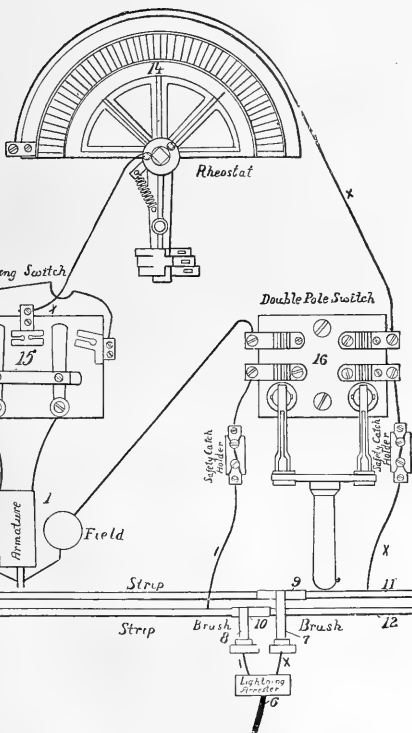

ELECTRIC DRAWBRIDGE PLAN.

reversing-switch to change the direction of rotation of the armature. The armature, rheostat, and fields are connected in series.

The double switch, fuses, reversing-switch, and rheostat are enclosed in a water-tight box in the framework of the bridge, and are

Houston motor, securely fastened to the draw by iron braces. One end of the motor-shaft is a pinion, which drives a train of gears, the last of which turns the shaft formerly operated by the men.

This installation is complete in every detail. Its operation is excellent, and reflects much credit upon the Thomson-Houston apparatus. The New England Electric Supply Company has received much praise from mechanical and electrical engineers for the excellent work they have done here, and has applied for patents on the devices used, and is in communication with several cities contemplating installations of the same nature.

A NEW FORM OF SECOHMMETER.

At a recent conversation of the Salters Company in London, a new direct-reading secohmmeter of Professors Ayrton and Perry was shown. This has been designed as a cheaper form than the older instrument, and is intended to be used in comparison of the co-efficients of self and mutual induction. The apparatus, with the cover removed, is shown in the accompanying illustration, taken from the *London Electrician*.

In the earlier forms of the secohmmeter, only a make and break were successively made in the battery-circuit, and the circuit of a shunt to the galvanometer; but, by the use of the double commutator in the new form of secohmmeter, the sensibility of the arrangement is increased fourfold: for, if there be any want of balance in the co-efficients of self or mutual induction that are being compared with one another, or with the capacity of a condenser, the galvanometer receives an impulse in the same direction at every reversal of the battery, which impulse is twice as great, and occurs twice as often, as if the galvanometer-needle received an impulse either only at the making or at the breaking of the battery-circuit, as in the earlier forms of secohmmeter. The fly-wheels make 10 revolutions for every revolution of the handle; and although, by the simple alteration of the gearing previously referred to, the commutators can be driven at will, so as to make either two reversals or eight reversals for every revolution of the handle, the ratio of the speed of the fly-wheel to the speed of the driving-handle always remains the same, so that the fly-wheel action remains constant. The driving-handle can be conveniently turned by hand at speeds varying from about 60 to 200 revolutions per minute, producing with one arrangement of the gearing 120 to 400 commutations per minute; so that both the battery and the galvanometer circuits

can be conveniently commutated from about 120 to 1,600 times per minute, the lower speeds being used for circuits having a large time-constant, and the higher for circuits with a smaller time-constant. The exact range of commutation, however, is made different in the various secohmmeters intended for different purposes.

When the instrument is intended to be employed for absolute measurements of the co-efficient of induction or the capacity of a condenser in terms of a resistance and a time, a speed-indicator is attached to the spindle seen projecting from the commutator in

The commutators can be driven at one or other of two speeds relatively to that of the driving-handle. With one arrangement there are rather more than 8 reversals of both the galvanometer and of the battery for one revolution of the handle; and with the other, 24 reversals of each for one revolution of the handle. The secohmmeter can be conveniently driven by hand, so as to obtain a steady speed of 300 to 6,000 reversals per minute of both the galvanometer and the battery.

To shift from one speed ratio to the other, press down the end of

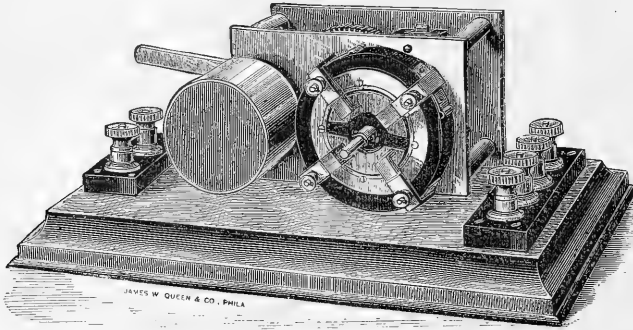

FIG. 1.—AYRTON AND PERRY SECOHMMETER.

the figure. But for comparison of the co-efficients of self or mutual induction with one another, or with the capacity of a condenser, no speed-indicator is necessary.

Another use to which the secohmmeter can be put is the measurement of the resistance of a liquid which is liable to polarize with direct currents, but which, as is well known, will not polarize with rapidly alternating currents.

This instrument consists of two rotatory commutators, each with four stationary brushes. The commutators are on the same

the locking-lever at the right of the secohmmeter, and slightly push in or pull out the handle, turning it slightly to assist the toothed wheels engaging properly. When engaged, let go the end of the locking-lever.

1. To compare two co-efficients of self-induction, join up the apparatus as in Fig. 2;¹ then, if the resistances r_1 and r_2 , of the non-inductive branches of the bridge, be adjusted to give balance with a steady current, balance will also be obtained on rotating the secohmmeter, when

$$\frac{L_1}{L_2} = \frac{r_1}{r_2},$$

L_1 , L_2 , being the co-efficients of self-induction of the inductive branches. The speed at which the secohmmeter is driven need not be known, but the greater the speed the more sensitive the test; the rate of reversal must not, however, be too great for the currents to reach their steady values between two consecutive reversals.

2. To compare two capacities, join up the apparatus as in Fig. 3; then balance will be obtained on rotating the secohmmeter, when

$$\frac{F_1}{F_2} = \frac{r_2}{r_1},$$

F_1 and F_2 being the capacities of the condensers, and r_1 and r_2 the resistances of the non-inductive branches of the bridge. As before, increasing the speed at which the secohmmeter is driven, merely increases the sensibility of the test without affecting the ratio connecting the capacities with the resistances.

3. In similar ways two co-efficients of mutual induction may be compared with one another, or a co-efficient of mutual induction with a co-efficient of self-induction, or either of these with the capacity of a condenser shunted by a non-inductive resistance.

4. To measure a co-efficient of self-induction absolutely in secohms by the comparative deflection method, attach a speed-indicator to the commutator spindle, which is prolonged for this purpose, and join up the apparatus as in Fig. 4, L being the co-efficient of self-induction to be measured, and r_1 , r_2 , r_3 , values of the three non-inductive resistances that give balance with a steady current. Rotate the secohmmeter handle at some convenient speed, causing the commutator spindle to make n revolutions per second, and observe the steady deflection, d_1 , of the galvanometer. Next stop the

¹ The continuous lines represent the permanent connections in the secohmmeter itself; the dotted lines, connections temporarily made outside the instrument.

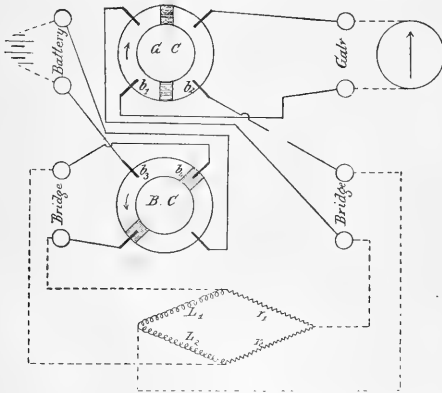

FIG. 2.—COMPARING TWO CO-EFFICIENTS OF SELF-INDUCTION.

spindle, one at the front, and the other at the back of the secohmmeter, but for convenience they are shown in the accompanying symbolical figures as if they were in the same horizontal plane; in reality, however, the brushes, b_1 , b_2 , b_3 , b_4 , are at the top of the instrument. One commutator, $G.C.$, is for periodically reversing the battery connections; and the other, $B.C.$, for reversing the galvanometer connections; and the other, $B.C.$, for reversing the battery connections. An adjustment is provided for enabling the relative positions of the two commutators to be varied, so that both reversals can be made to occur simultaneously, or one a little before or after the other, or one reversal midway between two successive reversals of the other.

secohmmeter, and increase or diminish one of the resistances, r_1 , for example, by a small amount ρ , obtaining a steady deflection, d_2 , of the galvanometer with the battery previously used; then

$$L = \frac{d_1}{d_2} \cdot \frac{r_3}{r_2} \cdot \frac{\rho}{8n} \text{ secohms approximately.}$$

For this test the relative positions of the two commutators is unimportant. They may be as in Figs. 2 and 3, in which case the

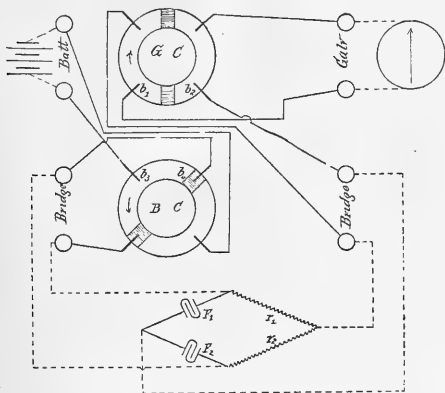

FIG. 3.—COMPARING TWO CAPACITIES.

reversal of the galvanometer occurs midway between two consecutive reversals of the battery; or they may be as in Fig. 4, in which case the reversal of the galvanometer just precedes the reversal of the battery. The greater the value of n , the greater will be the deflection d_1 , and the more accurately can it be read; but speed must not be too great to prevent the currents reaching their steady values between two consecutive reversals of the battery. Whether this condition be fulfilled or not, can be best ascertained

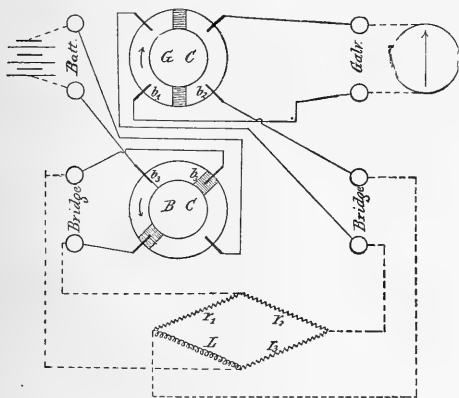

FIG. 4.—CO-EFFICIENT OF SELF-INDUCTION IN SECOHMS.

by seeing whether the same value is obtained for L , for a speed considerably smaller than n .

The sensitive zero method is as follows: Instead of obtaining two deflections, the resistances, r_1 , r_2 , r_3 , are first adjusted to give balance with a steady current, and then one of them, say r_1 , is altered by an amount σ ohms, so that there is still no deflection of the galvanometer when the commutator spindle makes, say, n revolutions per second; then

$$L = \frac{r_3}{r_2} \sigma \frac{k}{n} \text{ secohms approximately,}$$

where k is a constant depending on the relative position of the

commutators. The value of the constant k is most accurately ascertained once for all, for a given relative position of the commutators, by experimentally determining the value of $\frac{r_3}{r_2} \sigma$, that pro-

duces balance for a known co-efficient of self-induction, when the commutator spindle is driven at some known number of revolutions per second.

For this latter test it is necessary that the commutators be so placed relatively to one another that the galvanometer is not reversed exactly midway between two consecutive reversals of the battery; since, with this latter adjustment, no variation in the resistance of any of the arms of the bridge can counterbalance the effect of the self-induction on rotating the secohmmeter handle: in fact, the more nearly the commutators are placed in the midway adjustment, the smaller will be the value of k , and therefore the

larger the value of $\frac{r_3}{r_2} \sigma$, to produce balance for given values of L and n .

5. To measure the resistance of a polarizable electrolyte, replace the coil having self-induction in Fig. 4 by the polarizable electrolyte; adjust the commutators so that the galvanometer is reversed just before the battery; and, using the higher speed ratio for the gearing, rotate the secohmmeter at the highest convenient speed. Then, if x be the true resistance of the electrolyte,

$$x = \frac{r_3}{r_2} r_1$$

THE RATTLESNAKE'S RATTLE.

MR. S. GARMAN of the Museum of Comparative Zoölogy, Cambridge, Mass., has been investigating the rattle of the rattlesnake. The habit of sloughing is common to all serpents. A short time before the removal of the old skin takes place, the new epiderm makes its appearance beneath the old. The mode of growth of the new and the removal of the old is the same in all snakes, with the exception that in those with a rattle that portion of the slough that covers the tip of the tail is retained to form one of the rings of the rattle. The attachment is simply mechanical: the rings are merely the sloughs off the end of the tail. The terminal bone of the tail is formed of vertebræ that have coalesced, and changed in great measure their shape. In the different species the number of vertebræ included in this bone varies considerably, and sometimes it varies in individuals of the same species. With the purpose of indicating the manner of growth of the rattle, and as far as possible determining its origin, Mr. Garm an has followed up its appearance in several species, full details of which, with figures, have been lately published. In the very young rattlesnake, while the vertebræ are still separate, there is no rattle; but about a week after birth a well-marked button is seen. With the first slough the first ring is set free, the button being pushed forward, and a third button is gradually perfected. In time the traces of the vertebræ in the terminal bone are almost obliterated. The bone becomes thickened, pushed forward at its edges, and otherwise enlarged. In a full-grown rattlesnake the hinder seven of the rings belong to the period of the snake's most rapid growth,—they form the "tapering rattle" formerly used in classification of the species,—while four of the rings and the button are formed while the gain in size was less rapid, and form the "parallelogrammic rattle" of the old classifiers. Many serpents besides those possessed of a "crepitaculum" are addicted to making a rattling noise by vibrations of the end of their tails. In illustration of the extent to which the tail has been modified in different cases, Mr. Garm an figures the tails of several species, among others that of *Ancistrodon contortrix*, Lin., the copperhead of the United States. The tip of its tail is directed downwards as well as a little backwards. Most often the button has one or two swellings in a degree resembling those on a ring of the rattle. A living specimen of this snake, kept for a year or more, would take to rattling on the floor whenever it was irritated. The sound was made by the terminal inch of the tail, this part being swung from side to side in the segment of a circle, so that the tip might strike downward. The result was a tolerable imitation of the sound made by a small rattlesnake.

WASHINGTON'S SIGNATURE.

DR. PERSIFOR FRAZER published in 1886, in the "Proceedings of the American Philosophical Society," a paper on composite photography as applied to handwriting.

George Washington's signature was one of the first to sug-

In writing his signature, Washington put pen to the paper five times. First, he wrote the *GW* in one connected line. Second, he raised his hand and made the small *o* between the upper parts of the *G* and *W*, and the two dots which appear in all but signature No. 7. Third, his hand and arm were placed in position to write *ashing*, these six letters occupying a breadth of almost exactly $1\frac{1}{2}$ inches in every signature except the third, when they are extended to $1\frac{1}{8}$ inches. This is about as much of the arc of a circle (of which the centre is the elbow pivoted on the table) as one with a fore-arm of average length can cause to coincide with the tangent, or the straight line across the paper which the lower parts of the letters follow, unless unusual effort be made, and a great deal more movement be given to the fingers. The *g* ends in a curved flourish, of which the convex side is turned upwards below the right centre of the name. The lower loop of the *g* in all the signatures and in the composite was cut off in preparing the plate. Fourth, he wrote the final *ton*. Fifth, he added the very peculiar flourish, above the right centre of the name, with the object of dotting the *i* and crossing the *t* at the same stroke.

In examining the composite, the effect of these various separate movements becomes manifest in its strengthened portions. It is hardly possible that any one, during the period of sixteen years which these signatures represent, or from 1776 to 1792, should have so schooled his hand to write a long name that the first inch or so of the writing should always occupy the same relative position to the body of the signature. It would take at least that much action for the hand and arm and pen to be brought into normal signature-writing condition; and especially is this so when this part of the writing is accompanied by flourishes, as it is in the case we are considering. The *GW*, and the little *o*, and the dots at the top, were the prelude, after which the arm was moved into position to write the main body of the signature, or the *ashing*. Of course, from the manner of making the dots, and the extremely small space they cover, their re-enforcement of each other in the composite was almost impossible, and, in fact, like other subordinate characters, they disappear almost completely. This latter is the part of the name which one would have expected to exhibit the greatest amount of uniformity, as in point of fact it does, with the exception of its terminal *g*, which shows more variation than any of the other letters, because at this point the limit of coincidence between the tangent line of the writing and the curve, of which the right fore-arm was the radius, had been passed, and a freer movement of the fingers was compensating for the increasing divergence. It is likely that Washington sometimes raised the hand between the end of the long *s* and the beginning of *h*, but he does not appear to have moved the elbow. All but the second signature are consistent with this view, and in the first, third, and fifth it is plainly indicated. In the others, as in the flourish above the sixth signature, the pen may not have marked. The fourth separate act of the penman was the formation of the *ton* after a movement of the arm. The breadth of the space occupied by these three letters is from $\frac{5}{8}$ to $\frac{7}{8}$ of an inch, or considerably

within the range of coincidence of the curve and straight line before referred to; and owing to this fact there is only a moderate degree of re-enforcement of the letters in the composite, because these letters might fall into the first or last parts of the 2-inch space which was the limit of movement with a fixed elbow. The fifth and last movement was the flourish which dots the *i* and crosses the *t* by one stroke.

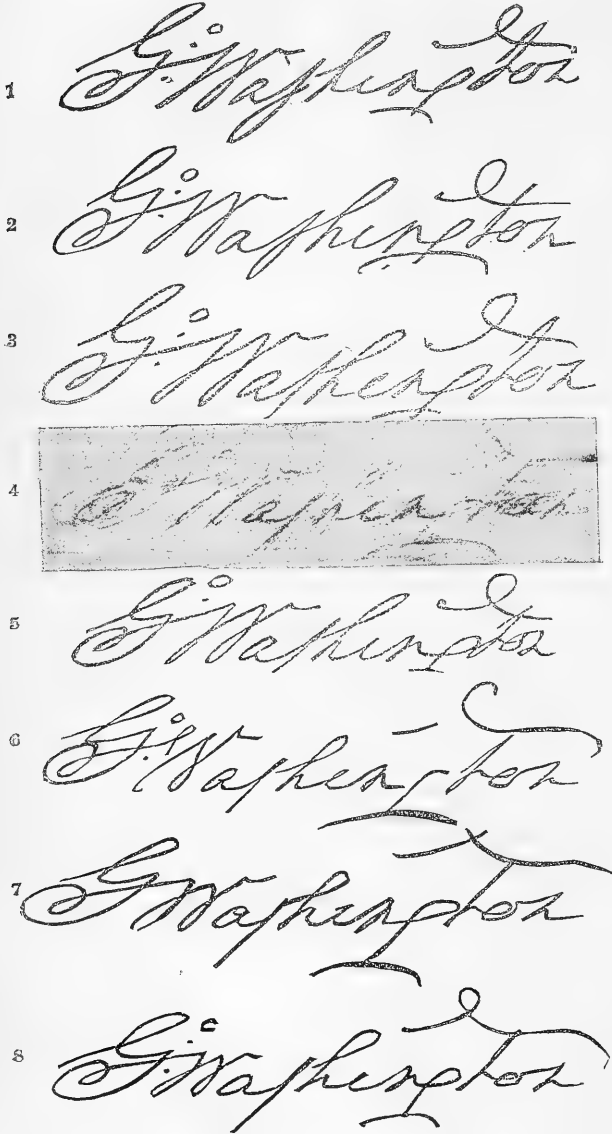

gest itself for the purpose, because many persons were familiar with it, and there are numerous well-authenticated documents in existence which bear it; but it has proved to possess other advantages which were not known when it was selected. As in every thing else, Washington was deliberate, painstaking, and uniform in his method of writing his signature, and the consequence is that it makes an excellent composite for illustration.

METHODS AND MODELS IN GEOGRAPHIC TEACHING.¹

It is important in teaching the physical geography of the land that the forms of the earth's surface which are to be considered should be selected and arranged in accordance with some natural and if possible genetic system of classification, and that they should be so clearly illustrated as to impress their essential features vividly on the minds of the students. While continental relief and outline should have brief elementary attention, more deliberate study must be devoted to the small rather than to the large areas of the land, the boundary of each area being determined by the extent of a single kind of structure. A single structural area, may be called a geographic "individual;" and all the individuals of one kind are to be idealized in a type. The types of the land-forms are then to be classified, first, according to their structure; and, second, according to the degree of advance that they have made in their destructive development, that is, according to their age. Any individual form may be imagined to pass through a cycle of life, beginning when its surface is presented to the destructive forces of the atmosphere, and ending when these forces have reduced the mass to the level of drainage discharge, that is, to the base-level of erosion. The sequence of forms assumed in this cycle of life is highly characteristic, and justifies the use of such terms as "youth," "adolescence," "maturity," and "old age," to indicate the degree of development that the individual has reached.

Models are employed to impress on the class the essential features of the various types. The models are of a size large enough to be seen by a class of fifty or a hundred students. They are made of paper, colored to indicate certain features, and arranged in nests of two, three, or four, for easy packing. Each nest or group of models represents the successive forms assumed by a single individual as it passes from youth to age. In order to give concrete illustration of their use, the group of forms that may be included under the heading of plains, plateaus, and their derivatives,² is described at some length.

A very young plain, like that of the Red River of the North, still retains its embryonic or pre-natal constructional features. It is level; its drainage is poorly developed; and the few streams that have as yet cut their channels in its surface have only incipient valleys, narrow and shallow. The future of such a surface would find it traversed by deeper and wider valleys, and broken by more numerous side-streams, and the originally smooth inter-stream surface becomes broken and diversified. While we cannot wait to see this change in the plains of the Red River, we may elsewhere find it already reached in the more advanced or adolescent stage of other plains, born longer ago, such as the coastal plains of the Carolinas. A still later form is found in the sub-mountainous country of West Virginia, where all resemblance to the initial smooth surface is long ago lost, but where the horizontal structure of the bedded rocks assures us that in its youth this surface was as smooth as the Red River plains are to-day. West Virginia is in its maturity, for here we have the greatest variety and strength of topographic expression. The drainage is most perfectly developed. The streams are most numerous, and carry at this time the greatest share of land-waste to the sea. Central Kentucky is still further advanced. Here the intensity of relief has diminished; for, while the hill-tops have lost some of their initial elevation, the valley-bottoms have not correspondingly gained in depth, having already at or before maturity reached close to base-level, below which they cannot cut. Maturity is passed when topographic expression thus begins to fade. Further advance still more reduces the relief of the surface, until in old age the region is a broad low land, whose monotony is only here and there relieved by low hills, while idle streams wander on the faintest gradients to the sea. The plains about the upper waters of the Missouri in eastern Montana illustrate this stage, — a broad, gently rolling expanse, overlooked by an occasional lava-capped mesa, where erosion has been resisted. When the lava of the cap was poured out from some neighboring vent, it ran down hill to the lowest place that it could find, and there accumulated: the mesas are therefore witnesses to the greater

height to which the whole surface once rose. And in the denudation of the original mass to its present ultimate form, it must have passed through all the stages represented by the examples already quoted; it must have had an initial level surface. This was trenched by young and growing valleys, shallow and few in number at first; deeper, wider, and more numerous later on; until in maturity there must have been in this now monotonous country a wilderness of rugged hills and a labyrinth of branching valleys. But as the hills wasted away, the land standing relatively quiet all the while, the relief was lessened, and finally the gently rolling plains of the present time were evolved.

Interruptions in a simple cycle of growth are seen on a closer examination of some of the examples given. The old plains of eastern Montana are no longer lowlands; they are now of considerable elevation above base-level; their rivers are swift, and flow in deep, narrow valleys, even where the rocks are soft and weak, and are interrupted by falls even where the volume of water is large. Manifestly, then, the whole region has lately been uplifted; that is, it has entered a new cycle of life, in which it has only reached early youth, and in which, if it is not interrupted, it will pass through another sequence of forms. The region of the high plateaus of Utah, as described by Dutton, is a wonderful example of the double control of form that appears in individuals not far advanced in a second cycle of growth. The general upland surface had entered maturity while standing at a lower level; it was then raised several thousand feet, and, thus rejuvenated, is now advanced a little way in its second cycle. The great cañons are only in their youth, though so profound: their depth is a sign of precocity, not of great age.

Variations in intensity of development characterize different individuals according as they stand at a great or small elevation above base-level. The coastal plains of the Atlantic slope cannot have deep valleys and strong relief, because their valleys are not allowed any considerable depth of cutting; while the cañons just mentioned give us the climax of intense expression by reason of the great height of the general upland surface over the base-level of the region.

Inasmuch as the association of topographic features at the several stages of development is strongly characteristic, it seems advisable to recognize this association in the manner ordinarily followed; that is, by the use of technical names, of which geography stands in so great need. In the same way, the types of different classes of individuals manifest throughout their life a characteristic succession of forms, such as is well known in those organic forms that undergo metamorphosis. Here again well-defined names applicable to the individuals throughout their whole life may be introduced to great advantage.

The history of a river may also be illustrated by the series of models, showing the first establishment of stream-courses on the lowest lines offered to the rainfall, the later adjustments and changes of streams by their mutual interaction, the accidents to which streams are liable from climatic change and otherwise. The shifting of streams by the mature adjustments of their drainage areas is regarded as a point of much importance in the development of the drainage of a region.

D. C. HEATH & Co. will publish at once "The Laws of Health in Relation to School Life," by Arthur Newsholme, M.D., diplomate in public health, University of London. It is a compend of sanitary science, useful to those who are erecting new school-buildings or modifying those already existing. It is of importance to all who are charged with the responsibility of watching over the mental and physical well-being of pupils of both sexes, in public or private schools or in boarding-schools. It is a book already in use in English training-schools. It has been carefully revised to adapt it to our climate and the needs of American schools. The London *Athenaeum* says of it, "It is wholly meritorious and altogether free from any blemishes that we can find. There is nothing to be said of it but that it is excellent." *Nature* says, "Dr. Newsholme has studied his subject thoroughly, and his conclusions are all the more valuable because they have been to a large extent suggested by his experience as a medical officer of health and as a medicinal referee for various schools and training-colleges."

¹ Abstract of a paper read before the Johns Hopkins University Scientific Association, Feb. 13, 1889, by Professor William M. Davis of Harvard College.

² See an article on this subject in the Proceedings of the American Association, 1884.

HEALTH MATTERS.

Bacteriology of Snow.

THE following extract from the *British Medical Journal* treats of a subject which is of great interest and decidedly novel:—

"While the bacteriology of ice and hail-stones has been studied with considerable success by Drs. Fränkel, Bischoff, Mitchell Prudden, Pumpley, Hills, Stoben, A. V. Poehl, Bordone-Ufreduzzi, Bujwid, etc., that of snow has been up to the present almost wholly neglected. Even in Russia the subject has been touched only in a cursory way by Professor A. V. Poehl of St. Petersburg, in the *Vratch*. In it he points out (1) that snow always contains viable microbes liquefying gelatine; (2) that, when snow falls, the first portions invariably contain greater numbers of bacteria than the subsequent ones (for example, 8,324 per cubic centimetre of snow-water, against 3,380 several hours later); (3) that, when snow lies on the ground, the superficial layers become richer in microbes (for example, 780 just after the fall, against 962 about three hours later). The fact is of interest from a sanitary point of view, as Dr. Poehl's researches furnish an additional proof that exposure of microbes to low temperatures does not destroy their vitality; at least, in certain species of micro-organisms.

"In many countries, such as Russia or Sweden, snow forms, so to speak, a natural ground or soil during several months of the year, receiving excrementitious matter and every possible kind of refuse and filth. In spring, when the snow melts, it is imbibed by the soil, carrying with it all the polluting matters referred to. Hence an interesting question arises, 'Are such microbes as happen to be present in these matters in any way changed by their contact with snow, or not?' This point can be determined only by further bacterioscopic researches.

"A contribution to the subject has just been published by Dr. F. G. Ivanovsky of Kiev, who has examined bacterioscopically, under Professor K. G. Tritshel's guidance, a February snow in its purest state, collected both immediately and from one to three days after its fall. This observer has found: 1. That, even when collected during its fall, snow is invariably found to contain living bacteria in considerable numbers, varying from 34 to 463 per cubic centimetre of snow-water. 2. That their number does not decrease from exposure of snow to low temperatures (-16° C.) for several days. 3. That the following three species of microbes are met with constantly in great numbers: (a) a large diplococcus composed of ovoid cocci, endowed with energetic motion, and characterized by its rapidly liquefying jelly (the test-tube culture on the third day, forming greenish colonies along the track of the needle, assumes the shape of a funnel-like sac with a whitish flocculent deposit, while on the fifth the whole medium becomes liquefied, the precipitate sinking to the bottom; on agar, a pale grayish-white streak is formed at the site of inoculation, on potato a fairly thick white film); (b) small-sized cocci, often arranged two and two, energetically mobile, and slowly growing on jelly without liquefying the medium, the growth proceeding solely along the track of the needle in the shape of a narrow stripe consisting of non-coalescing minute points of a yellow color, while on the surface the colony is seen as a grayish-white, circular, slightly prominent patch with somewhat fringed edges (on agar, the coccus forms a white streak with sinuous edges; on potato, a gray film with a brownish tint); (c) very large cocci, liquefying jelly as late as three weeks after inoculation, and growing along the track of the needle in the form of a sharply defined streak of a beautiful pink color, with a slightly elevated pink circular patch or 'cap' on the surface (on agar the microbe forms a freely spreading white film with a rosy tint; on potato, a thick, tallow-like, pink coat, with sharply defined fringed contours). 4. That the first two species, (a) and (b), are also met with commonly in the water of the river Dnieper, which flows through the town, while the peculiar pink micrococcus seems to occur only in snow. 5. That, generally speaking, the microbes liquefying jelly in falling or recently fallen snow are met with invariably in far greater numbers than in snow which has been on the ground for some time; this, in fact, very often contains only such bacteria as do not liquefy gelatine. 6. That the bacteria of snow originate partly from aqueous vapors which are transformed into snow; partly and chiefly from the air, that is, they are

carried away by the snow-flakes on their passage through the atmosphere."

SCARLET-FEVER.—At the annual meeting of the Rhode Island Medical Society, Charles V. Chapin, M.D., the health-officer of Providence, read a most valuable paper on the method for the prevention of scarlet-fever. In speaking of the origin of the disease, he said that where and when scarlet-fever first appeared is not known, but it has certainly prevailed continuously in Europe since the middle ages, and thence has spread to many other parts of the world. In 1735 it first appeared in this country at Kingston, Mass. It quickly broke out in Boston, a little later in New Hampshire, and gradually within a few years spread over New England, reached New York, and appeared in Philadelphia in 1746. Thence it extended down the coast, and passed over the Alleghenies into Kentucky and Ohio in 1791 and 1793. In 1851 it appeared in California. It was carried to New Zealand and Australia in 1848. During the first part of this century it was imported into Madeira, where it disappeared in 1814, only to re-appear in 1824. In South America it is said to have been prevalent in 1796, but became extinct, and appeared again in Chili in 1829, and in 1831 in Buenos Ayres, whence it spread in 1832 to Brazil. It first appeared in Iceland in 1827, in the Bahamas in 1845, and it was carried to India in a transport-ship in 1870. We know that the aborigines of Africa, North and South America, and Australasia were entirely exempt from this disease until the advent of Europeans. We know also that the early settlements were exempt often for many years; and we know that, in some cases at least, the direct transportation of the disease can be traced. These general facts, taken by themselves and without the corroboration of other testimony, show almost conclusively that scarlet-fever must be due to a material poison introduced from without the body, which poison must be intimately associated with the bodies of the sick. The hypothesis that the disease can be due to any atmospheric or telluric conditions is absolutely untenable. We should cease to talk about mysterious epidemic influences. Specific, by which is meant infectious, diseases can only be caused by specific poisons; and, though obscure meteorological conditions may favor or hinder the development and spread of these poisons, they cannot produce them. If scarlet-fever can be carried in ships half round the globe, or in emigrant trains hundreds of miles across uninhabited continents, and, set free at the journey's end, spread without hindrance, it must be caused by a specific poison. He refers to the work which has been done by Ecklund, Klein, Edington, and others, in the search for the germ of the disease, and comes to the conclusion that it has not as yet been discovered. Extended reference is made to the investigation which was made by *Science* in 1887 and 1888. He summarizes our knowledge of scarlet-fever in saying that it is a contagious disease, the virus of which behaves exactly as if it were a living organism; that it probably does not develop outside the living body, it is probably received through either the alimentary or respiratory mucous membrane; after a brief incubation, the disease is established, and the poison is thrown off from the mucous and cutaneous surfaces as long as inflammation exists or desquamation continues, and is thus disseminated in the air and attached to various articles, is carried from place to place, retaining its vitality for many months. For the prevention of the spread of the disease, he recommends that the patient be isolated; that a sheet wet with corrosive sublimate be hung before the door of the room which he occupies; that the patient be thoroughly anointed, including his head, morning and night, with the following, advised by Jamieson: carbolic acid, 10 to 30 grains; thymol, 10 grains in an ounce of ointment. Where it becomes necessary, and hospitals exist, patients should be removed to these institutions. At the close of the sickness, every thing should be disinfected. Dr. Chapin concludes his paper by quoting statistics from the report of boards of health, especially those of Massachusetts and Michigan, which demonstrate that sanitary measures have greatly reduced the prevalence of the disease.

DIPHThERIA.—Dr. J. Lewis Smith, in a paper read before the New York County Medical Association, entitled "The Cause, Mode of Propagation, and Prevention of Diphtheria," says the ex-

trema contagiousness of diphtheria from person to person is well known, and the virus adheres tenaciously to objects on which it happens to alight. The clothing of a patient, even when the disease is of the mildest form, his bedding, the furniture of his room, and the objects which he handles, may for weeks afterward communicate the disease. Dr. Sternberg, in his recent Lomb Prize essay, also mentions the fact that all damp, foul places, such as sewers, cellars, and ill-ventilated spaces under floors, afford conditions favorable for the development and propagation of the diphtheritic virus. The virus, once received, may be propagated in such a place for an indefinite time; and, ascending in the vapors which arise from this culture-bed, it is liable to communicate the disease to any one who inhales it. Thus in New York City prior to 1850, although foul sewers and unsanitary conditions existed, there was no diphtheria; but in the decade following 1850 this disease was introduced. The germ made its way into the sewers under ground; and now, wherever sewer-gas escapes into the domiciles of the city, it carries with it the diphtheritic poison. The amazing vitality and power of propagation of this virus are apparent when we reflect that it has permanently infected the New York sewers, so that children in all parts of the city are constantly falling ill with the disease.

THE BACILLUS OF TUBERCULOSIS.—According to M. Moulé, domestic fowls are frequently the subjects of tuberculosis, the disease often involving the abdominal organs. *Paté de foie gras* is sometimes almost a pure culture of tubercle bacilli. Dr. Squire of the London Epidemiological Society states that the bacillus of tuberculosis may enter the body (1) by inoculation through a cut or scratch; (2) by means of the genito-urinary mucous membrane; (3) by the product of conception, and by direct hereditary transmission; (4) by the mucous membrane of the alimentary canal; (5) by the mucous membrane of the respiratory tract, and by the air-cells of the lungs. The possibility of infection through the alimentary tract assumes importance from the prevalence of tuberculosis in animals which are used as food, and from the experimental proof of the infectiousness of the milk of tuberculous cows. The present state of knowledge on the subject points very strongly to the necessity for careful inspection of cattle kept for dairy purposes, and for precautions in using the milk, and possibly also the flesh, of diseased animals.

THE CONTAGIOUSNESS OF TUBERCULOSIS.—The New York Board of Health has passed the following resolution: Resolved, that Drs. T. M. Prudden, H. M. Biggs, and H. P. Loomis, the pathologists of this department, be and are hereby requested to formulate a brief and comprehensive statement regarding the contagiousness of tuberculosis in man, stating therein the evidence of the same, and recommending, in the briefest possible manner practicable, the simplest means of protection from its influence.

LEAD-POISONING.—At a meeting of the Practitioners' Society of New York, Dr. Kinnicut, the president, reported two cases of lead-poisoning occurring from an unusual source. The first patient was admitted to St. Luke's Hospital, suffering from lead colic and "wrist-drop." He had been employed as a florist; and on investigation by Dr. Vaughan, the house-physician, it was found he had been in the habit of biting off the ends of the tinfoil used as wrappers for hand bouquets. The tinfoil used for this purpose contained as much as eighty per cent of lead. There was no history of other sources of lead-poisoning. The second patient was admitted to the hospital, suffering from lead colic, and presenting a typical blue gum-line. He had been in the habit, for several weeks, of drinking beer from bottles which, he said, were cleaned by his employer with lead shot. Dr. R. F. Weir recalled the fact that several cases of lead-poisoning, some years ago, had been traced to the use of a popular brand of chewing-tobacco which was wrapped in tinfoil. Dr. Dana referred to some cases of poisoning which had been traced to the consumption of certain beverages coming in bottles with so-called patent stoppers. He said that he had recently had two Chinese patients in his hospital service, both of whom were suffering from lead-poisoning. He was unable to trace the source of the poisoning.

ELECTRICAL NEWS.

AYRTON AND PERRY'S SECOHMETER AND SECOHM STANDARD.—In default of a full description, we have to content ourselves with the announcement that Professors Ayrton and Perry will shortly put a standard secohm on the market as an accessory to their secohmmeter. The advantage of such a standard is evident, since it reduces the manipulations with the secohmmeter to a very few simple ones, and dispenses with the use of a speed-counter, or tacheometer, for absolute determinations with the mentioned instrument. This standard secohm will be used much in the same way as any standard resistance would be used in the Wheatstone bridge; in fact, the secohmmeter is nothing more than a very nicely constructed double commutator. Descriptions of the secohmmeter proper appeared in several of the electrical papers some time since. Nothing, however, was said about the use of this instrument. Through James W. Queen & Co., the sole agents for the Ayrton and Perry instruments, we have received a full description explanatory of the mode of using the secohmmeter for determining absolutely, or comparing, the co-efficients of self-induction. This description will be found on another page.

TOPEKA ELECTRIC RAILWAY.—The Topeka Rapid Transit Railway, the equipment of which has just been finished by the Thomson-Houston Electric Company, was put in operation on April 3. This road is said to be the longest in the world (14 miles, 20 miles of track). The trial trip was made on Wednesday, April 3, with four cars filled with invited guests, including the managers and chief officials of the Topeka City Street Railway and the East and West Side Circle Railways, and was satisfactory. The electrical apparatus consists of six 30-horse-power Thomson-Houston generators. The residents of Topeka are enthusiastic, and it is predicted that ere long electricity will be in general use on all the street-railways in the city.

EARTHING LIGHTNING-CONDUCTORS BY MEANS OF GAS AND WATER PIPES.—In the *Elektrotechnische Zeitschrift* (vol. xx, p. 473), A. Voller has an article on the above subject, an abstract of which appears in the *Journal of the Institution of Electrical Engineers*, No. 77. It is generally assumed that the path of the discharge follows only the line of least resistance, and no attention has been paid to the fact, on which Mr. Voller insists, that the direction of the discharge is chiefly influenced by the state of electric potential of the buildings in closest proximity to the charged cloud. The better the connection of the metallic masses in buildings is with the earth, the higher will be the potential of the induced electricity, and the greater likelihood is there of a discharge taking place between the cloud and the points in question. Since the general introduction of gas and water pipes into our houses, it is these which offer the least resistance between the roofs and earth. Hence, if a charged cloud should pass over such a house, the gas and water pipes must be at a higher potential, and there is much greater probability of the lightning entering the house through them than at any other point: in other words, it is more likely that the discharge will take place through the pipes than through the lightning-conductor; and, if the lightning-rod is not connected to the pipes, the discharge will find its way somehow to the latter, causing destruction in its path. At the request of the Hamburg fire insurance companies, Mr. Voller undertook to inspect cases of lightning-strokes, and to ascertain the point struck, as well as the path followed. A great many interesting cases investigated are duly recorded, but some general results only can be reproduced. It generally happened, that, when the building struck was unprovided with a lightning-conductor, the lightning struck some part of the roof or walls, found its way to the gas and water pipes, and then passed harmlessly to earth. In the few cases where lightning struck a building fitted with a lightning-conductor, the discharge jumped over from the conductor to the pipes. In fifteen cases which were specially investigated in the years 1884 and 1888, after the lightning had done more or less damage at the point where it struck, and in the immediate neighborhood, it was found that in nine cases the discharge made its way to earth through the water-pipes, in two cases through the gas-pipes, in two cases through rain-pipes, in one case probably through the lightning-conductor of

a telephone line on the next house, and in one case through an iron crane. In all cases where the pipes were the conductors, the path of the discharge could be clearly traced up to them, and then ceased. One of the cases of discharge through the gas-pipes occurred in an ordinary dwelling-house provided with a lightning-conductor, from which the discharge had passed over a distance of about two metres to the pipes. Subsequent tests showed that the conductor-earth had a resistance of 138 ohms. In no case was any damage done to the pipes by the discharge occurring through them.

NOTES AND NEWS.

THE following is a complete list of the papers presented and read to the National Academy of Science, at its meeting in April: "On Composite Coronagraphy," by D. P. Todd; "Additional Experimental Proof that the Relative Co-efficient of Expansion between Baily's Metal and Steel is Constant between the Limits Zero and 95° F." (read by title), by W. A. Rogers; "Notice on the Method and Results of a Systematic Study of the Action of Definitely Related Chemical Compounds upon Animals," by Wolcott Gibbs and Hobart Hare; "On Sensations of Color" and "Determinations of Gravity," by C. S. Peirce; "On the Pliocene Vertebrate Fauna of Western North America" and "On the North American *Proboscidea*," by E. D. Cope; "On the Mass of Saturn," by A. Hall, jun.; "On the Nature and Composition of Double Halides" (read by title), "On the Rate of Reduction of Nitro-Compounds," and "On Some Connection between Taste and Chemical Composition," by Ira Remsen; "Recent Researches in Atmospheric Electricity," by T. C. Mendenhall; "Measurement by Light-Waves," by A. A. Michelson; "On the Feasibility of the Establishment of a Light-Wave as the Ultimate Standard of Length," by A. A. Michelson and E. W. Morley; "On the General Laws pertaining to Stellar Variation," by S. C. Chandler; "Review of the Trivial Names in Piazzi's Star Catalogue," by C. H. F. Peters; "On Cretaceous Flora of North America," by J. S. Newberry; "Terrestrial Magnetism" (read by title), Cleveland Abbe; "Spectrum Photography in the Ultra-Violet," by Romyň Hitchcock; "North American *Pelagida*" (read by title) and "Development of Crustacea" (read by title), by W. K. Brooks; "The Plane of Demarcation between the Cambrian and Precambrian Rocks," by C. D. Walcott; "Report of the American Eclipse Expedition to Japan, 1887," by D. P. Todd.

— While it will be a long time before compound locomotives will be in extensive use in the United States, the time is not far distant when, in the opinion of the *Railroad Gazette*, they will receive considerable attention and extended trials on our railroads. The demand for decreased operating expenses is becoming too strong, particularly the demand made for a more economical use of fuel, to permit the discouragement of any promising innovation which indicates the possibility of a reduction of fuel-consumption. The saving which is claimed for the double-expansion locomotives in Europe, fifteen or twenty per cent, is sufficient, when applied to the coal-bills of some of our Western roads, to pay a dividend of one per cent; and it is not likely that such a promised saving, offered with so little radical change as that resulting from the introduction of double-expansion engines, will be allowed to pass without notice. It would be well to remember that there is no inherent evil in the compound locomotive which would render it objectionable in American railroad-service. Any representation that it cannot start heavy trains or propel them up steep grades is wholly without foundation. Some of the most powerful locomotives on the face of the earth are compound engines, working on the heavy grades in the mountains of the Eastern Continent.

— Entrance examinations for the Massachusetts Institute of Technology will be held in Boston on May 30 and 31. A second series, for those unable to be present in May, will be held on Sept. 24 and 25. For the convenience of applicants outside New England, entrance examinations will be held on May 30 and 31 in the following cities: New York, at the Fifth Avenue Hotel; Philadelphia, at the Lafayette Hotel; Montreal, at the Windsor Hotel; Chicago, Board of Education rooms, City Hall; St. Louis, office of

the superintendent of public schools; Cincinnati, office of the superintendent of public schools; San Francisco, 211 Drumm Street; Washington, United States Geological Survey; St. Paul, High School Building; Pittsburg, at the rooms of the Engineers' Society of Western Pennsylvania; Kansas City, at the office of the Board of Education. Candidates for admission will be allowed, at their option, to divide their entrance examinations between two successive years. The first divided examination will be held only in June; the second, in either June or September of the following year. To be admitted to the first divided examination, the candidate must be at least sixteen years of age, and must have notified the secretary of the faculty, at least two weeks before the date fixed for the examination, of his intention to apply. This notification must be accompanied by a list of the six subjects in which he will submit himself, and by a certificate from his teacher stating that he is qualified in them.

— The Zoological Museum at Leyden, one of the most considerable on the Continent, we learn from *Nature*, has narrowly escaped a terrible disaster. On Monday, the 1st of this month, a fire broke out, and all the resources of the officials and of the town were taxed to extinguish it. Indeed, it was not got under until a considerable portion of the collection of specimens of hollow-horned ruminants had been destroyed. Had the accident, which arose from the defect of a flue, taken place at night instead of in the afternoon, when plenty of assistance was promptly at hand, it is believed that the whole museum would have perished. The authorities of other museums, especially those which contain many spirit preparations, should not neglect this warning.

— We have already mentioned that an international meeting of zoologists will be held in Paris in August. The president, according to *Nature*, will be M. Milne-Edwards, and some important questions will be submitted for consideration. Among them will be the question of the unification of the language of zoology in classification and specific denotation. M. R. Blanchard has prepared an important report on the subject, which will be published shortly in the *Revue Scientifique*, and form the basis for the discussions at the congress.

— The Physiological Congress which is to be held in Basle in September will be attended, says *Nature*, by many French physiologists, if all those who propose to go are able to carry out their intention.

— The Eiffel Tower continues to be the hero, so to speak, of various adventures. According to *Le Génie Civil*, which is its official biographer, a story was circulated not long ago in Paris to the effect that it had begun to lean. The outline of the structure makes it very difficult to see whether it is vertical or not; and the rumor spread rapidly, until it came to be asserted that the tower would soon resemble the Leaning Tower of Pisa, to which it was constantly compared. There was no reason whatever to suppose that any movement had taken place; but the public solicitude became serious enough to make it advisable to have the matter tested, and two engineers were sent with theodolites to make a careful survey. As there are no vertical arrises in the tower, the method of observation employed was to trace the intersection of two vertical planes meeting at right angles in the centre of the tower, and bisecting each face. This was done, and the two theoretical planes were found to divide the faces of the tower with almost perfect symmetry, showing that the shaft was not inclined in any way from the vertical. On three of the sides the curvature was found to be exactly as designed, while the fourth side showed a hollow amounting to about an inch of deviation from the intended line. In another affair the tower is the aggressor, instead of being the victim of outside malice. It seems, says the *American Architect*, which is no friend of this structure, that the structure claims to be a work of art, like a picture or a statue, and to be therefore entitled to the benefit of the statutes for the protection of artistic property. Whatever rights of this kind may attach to it have been assigned to a M. Jaluzot, who has undertaken to defend his acquisition by claiming that all persons who sell photographs, models, pictures, or representations of any kind, of the tower, must pay him a royalty on such sales of twenty per cent on the price. As pictures and

photographs, to say nothing of models, large and small, in gold, brass, bronze, and many other materials, are for sale all over Paris, the royalty would amount to a very substantial sum, and some of the dealers interested have refused to pay; so that the whole question of the right of the structure to the protection accorded to pictures and poems is now before the tribunals, and the result will be awaited with some curiosity.

—The *American Architect* calls attention to an improvement recently introduced into the design of boilers, which promises to effect an important economy in the production of steam. An article in *Le Génie Civil*, by M. Lisbonne, a retired director of naval constructions, describes some experiments made with a boiler furnished with tubes having ribs, or flanges, on the inside, so as to present a larger surface for absorbing the heat of the fire. The projection of the flanges is about one-quarter of the diameter of the tube, and eight of them are spaced at equal distances around the inner surface. The tubes, which are the invention of M. Jean Serve of Gisors, are now drawn by special machinery out of brass, so that they require no soldering, and are strong and easily cleaned. The first experiments with them were made in a steamboat on the Rhone. A boat with copper tubes of the ordinary kind was carefully watched, and it was found that the combustion of one pound of coal would evaporate seven pounds of water, while the temperature of the smoke as it issued from the boiler was 680° F. The tubes were then taken out and replaced with M. Serve's tubes, and the evaporation immediately rose to nine and one-third pounds of water for every pound of coal consumed, and the temperature of the escaping gases fell to 460°. These results would seem to indicate an economy of about one-third in consumption of coal; and some other experiments, in which the quantity of coal consumed was observed, showed an actual saving of twenty-four per cent in coal. At the naval arsenal in Brest some further tests were then made by officers of the government, with the result that with natural draught the economy of coal effected by using the flanged tubes in place of smooth ones was, with a given quantity of water evaporated, fourteen per cent, while with forced draught the economy was eighteen per cent.

—*Garden and Forest* states that thousands of acres have this year been planted with fruit-trees in those districts of southern California where the "land-boomer" recently set all the world mad with speculation. In the San Joaquin valley large numbers of new settlers have lately established themselves in colonies for the purpose of fruit-growing, dividing their land into twenty and forty acre tracts. In San Diego County the acreage devoted to this industry is five times as great as it was a year ago, and in Los Angeles and many other counties it is one-third greater; and, moreover, the old "placer-mining" counties are rapidly transferring their attention to fruit, and it is now the richest crop of Tuolumne, for example, once a conspicuous centre of gold-production.

—The next congress and exhibition of the English Sanitary Institute will be held in Worcester, England, at the end of September.

—The Watson gold medal and a hundred dollars in gold, founded by Dr. James C. Watson, for the most important discoveries in astronomy, have been awarded to Dr. Edward Schonfeld of the University of Bonn, Germany. The medal is given to Dr. Schonfeld for his researches concerning the variable stars, and for his work in cataloguing the stars brighter than the tenth magnitude, from the equator to the southern tropic.

—The regents of the Michigan State University have appointed Professor John Dewey, now professor of philosophy in the Minnesota State University, to the chair of philosophy, made vacant by the death of Professor George S. Morris. Professor Dewey was for several years assistant to Professor Morris. The title of assistant professor of mechanical engineering was conferred upon Lieut. L. D. Miner, who was recently detailed for service here by the secretary of the navy. The resignation of Dr. C. H. Stowell, professor of histology, was presented and accepted, to take effect Oct. 1, as was that of Professor J. W. Langley from the chair of general chemistry and metallurgy, to take effect June 30, and Louisa Reed-Stowell, assistant in microscopical botany, to take effect Oct. 1. It is announced that the widow of the late Professor Elisha Jones has

established a fellowship with \$10,000, to be named after her lamented husband.

—At the business session of the National Academy of Sciences at Washington, D.C., held on the morning of April 18, a home secretary and council, consisting of six members, were elected. Professor Asaph Hall, who has served six years as home secretary, was re-elected. The members of the council elected were Professor George J. Brush of New Haven, Conn.; Gen. Francis A. Walker; Benjamin Apthorp Gould of Cambridge, Mass.; Professor Ira Remsen of Johns Hopkins University, Baltimore; Gen. Montgomery C. Meigs; and Professor Simon Newcomb. The following new members of the academy were elected: Professor Boss of Dudley Observatory, Albany, N.Y.; Professor Sereno Watson of Harvard; Professor C. S. Hastings, Sheffield Scientific School, Yale University; Professor C. A. White, United States Geological Survey; and Professor Michel of Tufts College, Massachusetts. This makes the list of membership number exactly one hundred,—the first time in the history of the academy that this number, which the unwritten law of the academy fixes as a maximum limit, has been reached.

—At a meeting on April 18, of the trustees of Clark University, the Hon. John D. Washburn, recently appointed minister to Switzerland, resigned the office of secretary of the corporation. The work of the university will begin October next in mathematics, physics, chemistry, and physiology, besides the study of languages. The departments will be gradually organized, and on the highest plane possible. While not declining to confer the degree of A.B., the university will for the present give attention to qualifying for higher degrees. Ten fellowships of four hundred dollars, ten of two hundred dollars, and ten scholarships with free tuition, have been provided for.

—From Denver, Col., Mr. J. Wylie Anderson writes to the *American Field* that on a hunt last fall, in company with F. A. Williams, he secured a very rare specimen of clustered antlers, there being thirty-two well-developed spikes,—eighteen on one horn, and fourteen on the other. Another peculiarity about them was that the four main prongs were present on each horn, and extra spikes developed on the outer surfaces of the horns, and that gave them the enormous spread, which at the widest part was thirty-eight and one-half inches. The deer was a very old one, and the beams were very large. The great spread of antlers was almost as great as those of an elk he killed on his trip. Mr. Williams has his specimen mounted, and it adorns his office walls.

—The establishment of the Blue Hill Observatory, and its equipment with means for obtaining meteorological observations of the best class, made it appear probable that the observatory of Harvard College could do more service to science by assisting in the publication of the results obtained at Blue Hill than by enlarging its own field of meteorological work. Accordingly proposals were made for co-operation between the two institutions, which, through the courtesy of Mr. Rotch, the proprietor of the Blue Hill Observatory, have resulted in the arrangement in accordance with which the "Observations at the Blue Hill Observatory" is published as a part of the "Annals of the Observatory of Harvard College." Successive volumes of the Blue Hill observations will appear in the same manner, and the ultimate consolidation of the two institutions is contemplated.

—After having experienced a period of great prosperity, the silk industry in Greece, says the *Journal de la Chambre de Commerce de Constantinople*, is now in a depressed condition. The production of cocoons, which in 1855 amounted to between 1,200,000 and 1,400,000 kilograms, fell, in the period comprised between 1870 and 1880, to about 500,000 kilograms. Since the year 1884, this quantity has still further decreased; and the production, which is centred in the south of the Peloponnesus, in Messenia and Laconia, did not exceed 200,000 kilograms of cocoons, that is to say, a yield in silk of about 18,000 kilograms, of which about 10,000 kilograms are exported. This diminution must be attributed to the disease of the silkworms and to the low price of cocoons. Almost all the cocoons and silks from Greece are shipped to Marseilles, and Calamata is the principal port for shipment.

SCIENCE:

A WEEKLY NEWSPAPER OF ALL THE ARTS AND SCIENCES.

PUBLISHED BY

N. D. C. HODGES,

47 LAFAYETTE PLACE, NEW YORK.

Subscriptions.—United States and Canada.....\$3.50 a year.
Great Britain and Europe.....4.50 a year.
Science Club—rates for the United States and Canada (in one remittance):

1	subscription 1 year.....	\$ 3.50
2	" 1 year.....	6.00
3	" 1 year.....	8.00
4	" 1 year.....	10.00

Communications will be welcomed from any quarter. Rejected manuscripts will be returned to the authors only when the requisite amount of postage accompanies the manuscript. Whatever is intended for insertion must be authenticated by the name and address of the writer; not necessarily for publication, but as a guaranty of good faith. We do not hold ourselves responsible for any view or opinions expressed in the communications of our correspondents.

VOL. XIII. NEW YORK, APRIL 26, 1889. No. 325.

CONTENTS:

COMPOSITE PORTRAITS OF WASHINGTON.....	317	Topeka Electric Railway.....	319
CONGRESS OF ELECTRICIANS AT THE PARIS EXHIBITION.....	312	Earthing Lightning-Conductors by Means of Gas and Water Pipes.....	319
AN ELECTRIC DRAWBRIDGE.....	312	NOTES AND NEWS.....	320
A NEW FORM OF SECCHMETER.....	313	THE HENRY DRAPER MEMORIAL.....	322
THE RATTLESNAKE'S RATTLE.....	315	EXAMINATION AND EDUCATION.....	323
WASHINGTON'S SIGNATURE.....	316	ASCENT OF THE KILIMA NJJARO.....	324
METHODS AND MODELS IN GEOGRAPHIC TEACHING.....	317	STANLEY'S DISCOVERIES.....	325
HEALTH MATTERS.		THE INFLUENCE OF CERTAIN DRUGS ON PHYSICAL STRENGTH AND ENDURANCE.....	326
Bacteriology of Snow.....	318	BOOK-REVIEWS.	
Scarlet-Fever.....	318	Francis Bacon, his Life and Philosophy.....	327
Diphtheria.....	318	Curve Pictures of London for the Social Reformer.....	327
The Bacillus of Tuberculosis.....	319	Marriage and Divorce in the United States.....	327
The Contagiousness of Tuberculosis.....	319	AMONG THE PUBLISHERS.....	327
Lead-Poisoning.....	319	LETTERS TO THE EDITOR.	
ELECTRIC NEWS.		New Sources of Heat.....	X. 329
Ayrton and Perry's Secohmmeter and Secohm Standard.....	319		

THE HENRY DRAPER MEMORIAL.

The third annual report, just published, shows that the researches which constitute the Henry Draper Memorial have consisted for the last three years in the photographic study of the spectra of the stars. While this subject will continue to be the principal one under investigation, Mrs. Draper has decided to extend the field of work undertaken so as to include the study of the other physical properties of the stars by photography. The first research undertaken is now rapidly approaching completion, the plans for the study of the southern stars have been matured, and this study will soon be begun. The detailed study of the spectra of the brighter stars is making progress, and a large piece of photometric work will soon be undertaken with a new telescope.

The Bache telescope, which has an 8-inch photographic doublet as an objective, is used for the catalogue of spectra of bright stars. The photographs cover the entire sky north of -25° , with exposures of about five or ten minutes. About 28,000 spectra of 10,800 stars have been examined, including nearly all stars visible in Cambridge, of the seventh magnitude or brighter. The catalogue is now nearly ready for the printer.

In November, 1888, the photographs required to cover the sky north of the equator for the catalogue of spectra of faint stars were nearly finished. It was expected that in two months the observations would be completed. The telescope, which was the same as that used in the previous research, was, however, wanted for photo-

graphing the solar eclipse of Jan. 1, 1889. It was accordingly sent to Willows, Cal., where it was mounted, and the greater portion of the remaining photographs were taken there. It was then sent to Peru. The few remaining photographs, including the repetition of those found on further examination to be unsatisfactory, will be taken in Peru. The sky from -25° to the south pole will be covered for bright stars as well, and the resulting photographs sent to Cambridge and reduced, as in the case of the northern stars. The advantages of discussing all stars from the north to the south pole according to one system are very great, and are here secured for the first time in so extensive an investigation. If no unforeseen difficulty arises, the photographs will all be completed during the next two years.

The 11-inch refractor, with one, two, or four large prisms over its objective, has been employed in the detailed study of the spectra of the brighter stars throughout nearly every clear night, until stopped by the morning twilight: 686 photographs have been taken, most of them with an exposure of two hours. With the present photographic plates, about 570 stars north of -30° are bright enough to be photographed with one prism, 170 of them with two prisms, and 87 of them with four prisms. To obtain the best possible result, some of the photographs must be repeated many times. The difficulty is increased by the invariably hazy appearance of the lines in some spectra, like that of a *Aquila*, which was at first attributed to poor definition of the photograph. It is expected that the work will be completed during the next year by original or repeated photographs of 228 stars with one prism, of 64 with two, and of 12 with four. In general, stars as bright as the fourth magnitude can be satisfactorily photographed with one prism, the spectra obtained being about an inch long. Fainter stars, if of a bluish color, give sufficiently distinct images, in some cases good results being obtained with stars of the seventh magnitude. For example, fourteen stars in the Pleiades are well photographed with this apparatus. With four prisms, much longer spectra are obtained, and many more lines are visible. But certain differences in the character of the spectra are better shown with the smaller dispersion. Numerous photographs have been taken of the variable stars α *Ceti* and β *Lyræ*. The changes in the spectrum of the latter star seem to be undoubted; those of α *Ceti*, if any, to be slight. Various peculiarities in the spectra of individual stars have been detected. One photograph of ζ *Ursæ Majoris* shows the K line distinctly double, and others show it single. Many photographs will be required to determine the law of its variation, if this is due to changes in the star itself. Bright lines were detected in the spectrum of ϕ *Persæ*, putting it in a class in which only two or three other stars are known to fall. In the double star β *Cygni* the two components have spectra of different types,—an important consideration in the theories regarding their formation. The brighter component is of the second type; the fainter, of the first.

Ordinary photographic plates are not sensitive to rays of much greater wave-length than the F line, or 486. By staining the plates with various coal-tar products, the range of sensitiveness may be greatly extended. With erythrosine, the spectrum extends to the wave-length 590. The sodium line D is distinctly seen to be double in the photographs of a *Boötis* and a *Aurigæ*. Various experiments were also made with cyanine, but the plates were not sufficiently sensitive to give good results. The entire length of the spectrum with four prisms, including the portion obtained by erythrosine, is about six inches and a half.

A beginning has been made of the measures of the positions of the lines in the spectrum. A scale of fortieths of an inch has been ruled on glass, and the positions of the lines read off with the aid of a magnifying-glass. Twelve of the photographs of a *Canis Majoris* have been studied in this way. The spectrum of this star is traversed by the hydrogen lines, which are strong, and by other lines which are so faint that they are only visible when the dispersion is large and the definition good. The catalogue thus formed contains about 320 lines. The average deviation of the measures of the same line on different plates is about 0.05 of a millionth of a millimetre, or 0.05 centimetres on the scale of Angström's map. If the line occurs in the solar spectrum, these measures will generally identify it. In other cases the exact position

must be determined by a dividing-engine. If a line can be distinctly seen, its wave-length can probably be thus determined with as great accuracy as that of the position of the solar lines on the map of Angström. In the spectrum of a *Boötis* 140 lines are visible between the D and F lines.

The classification of this large number of spectra is a matter of no little difficulty. Slight differences exist in many stars, and certain stars appear to hold an intermediate position, so as to render a rigorous division into classes impossible. On the other hand, many stars appear to have identical spectra. The first step will be to arrange the stars in groups, and then compare the best defined spectra of different groups. A minute discussion and the measurement of wave-lengths will be necessary only in the investigation of a comparatively small number of spectra.

The 28-inch reflecting telescope constructed by Dr. Draper was assigned to the work on faint stellar spectra. During the first six months of the year a careful study was made of this problem, and the difficulties encountered bore evidence of the skill of Dr. Draper in obtaining good results with this telescope. The best method of using this instrument seemed to be a modification of the form first tried by Dr. Draper, — a slit spectroscope from which the slit had been removed. The rays from the mirror were rendered parallel by a concave lens which replaced the objective of the collimator. As this lens had the same focal distance as the objective of the observing telescope, it was not necessary that either should be achromatic. After long trials with this and other forms of apparatus, a spectrum was at length obtained showing good definition. As the results were not better than those described above, and the instrument, from its size, was slow in operation, the experiments have not been carried further.

The Bache telescope described above has proved an extremely convenient instrument for various purposes. Besides the spectroscopic researches already mentioned, several other investigations have been undertaken with it. Owing to its short focal length, it possesses many advantages over photographic telescopes of the usual form. With exposures of an hour and a half, more stars were photographed in the Pleiades than are given in the engraving accompanying the "Annual Report of the Paris Observatory of 1886," although that work was based on photographs taken by MM. Henry with exposures of three hours, and a telescope having an aperture of 13 inches. Nearly twice as many stars were photographed in this region as were visible with the 15-inch telescope of the Harvard College Observatory. The short focus of the telescope also gives it especial advantages for photographing nebulae. Twelve new nebulae were thus discovered in a region where but eighteen were known before. Various other investigations, such as a determination of the law of atmospheric absorption, have been undertaken with the aid of this telescope. It has been so persistently used in spectroscopic work that the other researches have been neglected, especially those in which very long exposures were required. Its removal to Peru now cuts it off for some time from such use on the northern stars. Accordingly, Mrs. Draper has procured a similar lens, which is now in the hands of the firm of Alvan Clark & Sons for retouching and mounting. Several important researches will be undertaken with this instrument. Photography is now used in so many departments of astronomy, that a general investigation of the photographic brightness of the stars seems desirable. A plan has been proposed by which a single plate will contain photographs of a number of regions one degree square, but in different portions of the sky. Thus a series of standard faint stars will be photographed, which can all be measured, and reduced to the same scale. One or more photographs of the vicinity of the north pole will be taken on each plate, and thus serve to correct the results obtained on different plates. It is proposed in this way to secure a series of standards of stellar magnitude at intervals of about five degrees. A third lens of similar form, having an aperture of four inches, will be attached to the telescope, with which photographs on a smaller scale, but five degrees square, will be taken simultaneously. These photographs will cover the entire sky, and it is proposed to measure the photographic brightness of all stars of the seventh magnitude, or brighter, which are represented on them. This investigation will have a special value in connection with the photometric measures of the spectra described

above. It is hoped also to photograph the entire northern sky by means of the 8-inch telescope, with exposures of an hour. Each plate covers a region nearly ten degrees square, of which the images in the central five degrees square are satisfactorily in focus. One of the regions containing standard stars will appear in the centre of each plate. By such a series of plates the photographic brightness of any stars brighter than the fifteenth magnitude can be determined on a uniform scale. The faintest stars photographed will be nearly a magnitude fainter than the limit proposed by the Astro-photographic Congress, so that all plates included in that work can be reduced to a uniform system. The advantages of such plates for studies of the distribution of the stars and other similar investigations are obvious.

From the above description it appears that the field of work of the Henry Draper Memorial, as now extended, is almost boundless. The problems to be investigated relate to the fundamental laws regulating the formation of the stellar system. Questions of such importance should be discussed on a sufficiently large scale, or the results of the discussion will soon be superseded by a repetition of the work. The liberal provision made for the Henry Draper Memorial permits the investigations to be planned on a scale which is likely to avoid such an undesirable duplication of work.

EXAMINATION AND EDUCATION.¹

FOR many years I have watched the examinations of young men in our colleges, with reference to the award of prizes and honors, and also with reference to the terms of admission to college and the conditions of bestowing academic degrees. The conclusions to which I have come are these: —

Daily marks, jotted down by the instructor at the close of an exercise, help him to form an accurate notion of the fidelity of his scholars and of their intellectual growth; but it is usually best for him to keep these marks private, and simply for his own guidance, lest by showing the record to his pupils he should accustom them to the notion that work is over when they have learned the lesson, solved the problems, or written the exercises acceptably. He must not teach them to read for marks, — an odious habit.

Examinations held at frequent intervals, say once a month, three or four times a year, or at the end of a certain obvious block of work, especially if preceded by a brief and spirited review, are as serviceable to the scholar as to the teacher. The true condition of a class can thus be ascertained and recorded. The scholar or his advisers can be informed whether or not he excels, is passable, or is deficient. The good students are thus encouraged to better work: the poor students are warned before it is too late to recover their standing.

Yearly examinations accustom the scholar to hold on to the knowledge that he has acquired. If rightly conducted, they remind the pupil that he must carry in his mind the general principles and the fundamental facts of the subject he has studied. A good examiner will put very different questions at an annual examination from those he would set at the end of a month's study. He will endeavor to ascertain whether the subject taught has been mastered by the individuals examined, not whether every detail can be instantly recalled.

Special examinations at marked epochs in an education — such as admission to college, competition for prizes, and the attainment of a degree — encourage young men to put forth their highest and best efforts, to make strong exertions, to overcome great difficulties. As an important part of the business of life is the overcoming of obstacles, so a good school or college should train its pupils to meet and master tasks that are hard. The well-trained youth will not shrink from such difficulties as he must encounter when he becomes a physician, a lawyer, a statesman, a teacher, an engineer, a philanthropist, an editor, a man of business; in short, when he takes an active part in the affairs of life.

In selecting men for high stations, for appointments by the government, or for college fellowships, or for the position of teachers, other tests than those of an examination must be employed. Evidence that the candidate has exact knowledge, and that his knowl-

¹ A contribution by President D. C. Gilman of Johns Hopkins University to the American Supplement to the Nineteenth Century for March.

edge can be readily and clearly communicated, may indeed be indispensable, and this may be ascertained by examination. But to judge of the general ability of a candidate, of his fidelity, his adaptation to a given position, the probability of his growth, his skill as a "re-searcher," his originality of mind, his perseverance, other tests must be employed than those of an examination-paper. Good judgment, based upon a knowledge of human nature, must be called in.

The advantage of allowing teachers to be the examiners of their classes is obvious: they know what has been taught, and how, and they can say what the scholar ought to remember. At the same time, the advantage of calling in examiners who have not taught the class is also obvious. Pupils are thus reminded that they are expected to know a subject, not a certain part of a text-book. For example: they are to know how to read Cicero, and not to present six orations; they are to read German books, not to say that they have read "Marie Stuart;" they are to know their algebra, their physics, their chemistry, botany, and so on. Probably for the best pedagogical discipline, the board of examiners should be made up partly of the actual teachers of a class, partly of competent, sensible outsiders.

While there is reason to believe that the lower schools of the country suffer from too many or too poor examinations, I doubt whether the colleges rely too much upon their examinations. Some instructors have but vague ideas of the purpose of examinations, and consequently may employ imperfect methods of examining. Examiners are as likely to be at fault as examinations.

It would surely be well for every board of examiners to consider what object they have in view; e.g., is the object to ascertain whether the class as a whole has been well taught? The authorities of a school or college sometimes require this information, and of course an examiner who is not the teacher must be enlisted. Is the object to select those who are most deserving of an honor or prize? If so, sharp test-questions are requisite. Is it to ascertain whether a scholar is capable of going forward with a proposed course of study? If so, a fair, general paper, supplemented if possible by oral questioning, is desirable. Is it to grade a class? Then there should be a paper which every one ought to be able to answer, so as to pass, but with riders, so that the superior scholars may show their attainments, and win the rank which is their due. The highest talents will thus be drawn out, while inferior ability will not be discouraged.

But the subject is quite too complex for a brief discussion, and I fear that I have already filled the space that you offer me.

ASCENT OF THE KILIMA NDJARO.

MR OTTO F. EHLERS made an interesting ascent of the Kilima Ndjaro in company with Dr. Abbott, an American naturalist who had been collecting for upwards of a year in the country round Tavita. The "Proceedings of the Royal Geographical Society" gives the following sketch of this ascent: The travellers left Marangu with a party of thirty men. The first camp was pitched at the foot of a small crater almost due south of the eastern peak, Kimawenzi, at an altitude of about 9,800 feet. On the following day Herr Ehlers made an excursion to Kimawenzi, and reached a height of about 16,400 feet; any further ascent of this remarkable jagged mountain seemed to him impossible. The same day the travellers saw three specimens of a new species of antelope. The two following days were spent in collecting plants and searching for a suitable camping-place, where the majority of native followers might remain, while the travellers proceeded up the mountain. A spot was chosen to the west of their last camping-ground, at an altitude of about 10,500 feet. From here the two travellers started with five men, and provisions for four days, taking a northerly direction up the saddle between Kibo and Kimawenzi. After some hours' marching, they discovered that they had made the same mistake Dr. Meyer had in 1887, and were proceeding in a direct line to the summit of the lower eastern peak. Being at this moment overtaken by a snow-storm, they pitched their camp at an altitude of about 15,500 feet. On the following morning, which broke bright and clear, they set out in a westerly direction over the

newly fallen snow, proceeding along the northern edge of the line of lava hills mentioned by Dr. Meyer, whose route lay along their southern side. After much toilsome marching, snow having commenced to fall again, the natives were compelled to return, leaving the two travellers to push on to their last camping-ground (Nov. 17). The morning of the 18th was exceptionally clear, and an early start was made over the hard-frozen snow. At seven o'clock they found themselves at an altitude of 16,200 feet, about the middle of the eastern side of the summit. Instead of attempting to ascend from this side, as Dr. Meyer had done, they proceeded in a north-westerly direction over lava-streams and rocky boulders to the northern side of Kibo. Unfortunately, at this point Dr. Abbott completely broke down, and Herr Ehlers pushed on alone. Keeping to the east of a mighty lava-stream, he pushed his way over sand, ashes, and rubble, covered with the freshly fallen snow, and after repeated halts, but without suffering at all from the rarity of

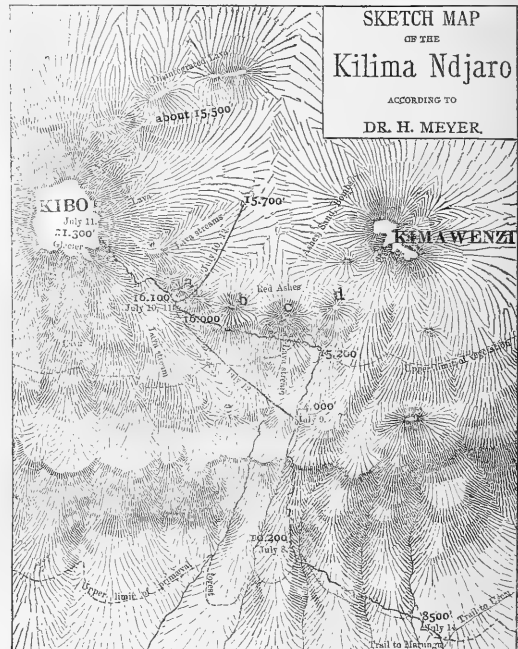

the atmosphere, he arrived at 10 o'clock at the ice-wall which completely encircles the actual summit, and the scaling of which at this point was impossible. He consequently proceeded along this wall of ice for some distance, in the hope of finding a point at which it could be surmounted, but after a time was compelled to retrace his steps, owing to a steep fall in the ground. Descending the summit a little, he contrived, by much toilsome climbing, to get round to the north-east side of the summit; and here, from a point of some little elevation, he obtained a comparatively wide view over the summit. He could discover nothing in the form of a crater: the mass of snow and ice lay before him in a succession of gentle undulations. This is somewhat remarkable, in view of Dr. Meyer's account of the crater of the summit. He does not give the exact height attained, as he prefers to wait until the instruments used have been tested, but states that it exceeds 19,600 feet. The descent was made by a somewhat different route, in a direct course to the south-east. At an altitude of 16,400 feet the track of an elephant was observed in the snow, also those of buffaloes and antelopes. Here also he found the last traces of vegetation. The return to Marangu occupied three days.

STANLEY'S DISCOVERIES.

THE accompanying map of the Aruvimi River has been compiled from two sketches, — one published in the *Mouvement Géographique*; the other, in *Nature*, — both being extracts from a map accompanying Stanley's letter. The original will presumably be published in the "Proceedings of the Royal Geographical Society." The names of places appear still somewhat doubtful, being differently given on the two sketches.

Stanley's discoveries form a most important addition to our knowledge of Central Africa. It appears that Mr. Wauters's hypothesis of the connection of the Nepoko and Aruvimi was well founded, as the former is an important tributary of the Aruvimi. It remains an open question whether there is any connection between the Aruvimi and the Mootan Nzige, the southern of the two large lakes. Mr. Wauters presumes that the Lunda (or Lenda), the southern tributary of the Aruvimi, may be the outlet of that lake, but we have to await more detailed reports before we will be able to form an opinion on this point. The tributaries which Mr. Stanley describes in his map have probably been drawn according to reports received from natives.

As to the river itself, the Aruvimi is, with its windings, about 800 miles long from its mouth in the Kongo to its source almost

It is a most remarkable fact that the source of the Aruvimi is in so close proximity to the Albert Nyanza. Another fact of great interest Mr. Stanley refers to, — the existence of a snowy mountain which may rival Kilima Ndjaro (19,000 feet), in the neighborhood of Mount Gambaragara, or Gordon Bennett, between Albert Nyanza and Muta Nzige. This may be Mount Gordon Bennett itself; but Mr. Stanley does not think so, and he is supported by the few data which he furnishes. It would be quite in accordance with what we find in other parts of the world that a group of high peaks should be found together.

One other point of geographical interest is Mr. Stanley's observation that the Albert Nyanza is rapidly decreasing in size. A century or perhaps more ago, the lake must have been twelve or fifteen miles longer, and considerably broader opposite Mbakovia, than it is now. With the wearing-away of the reefs obstructing the Nile below Wadelai, the lake has rapidly receded, and is still doing so, to the astonishment of Emin Pacha, who first saw Lake Albert seven or eight years ago. It is to be hoped that Mr. Stanley will find time further to investigate this subject, as well as to explore the country between the Albert Nyanza and Muta Nzige, settle the position and outline of the latter, and ascertain precisely to what river system it belongs.

The abruptness with which the forest comes to an end and the

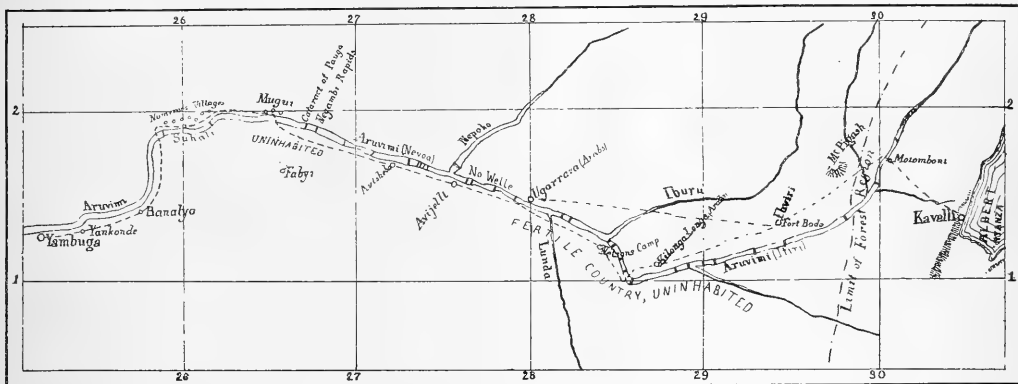

MAP SHOWING STANLEY'S GEOGRAPHICAL DISCOVERIES IN CENTRAL AFRICA.

on the edge of Albert Nyanza, though the course in a direct line is probably not more than 400 miles. The banks of the river, covered with forest from the Kongo to the Nepoko, are uniformly low, here and there rising to about 40 feet. Above the Nepoko, hills begin to crop up more frequently, palms are more numerous, and the woods show the tall white-stemmed trees so characteristic of the slopes of the lower Kongo. While there are rapids at several places above Yambuga, above the Nepoko navigation becomes much more difficult, and rapids more frequent, while two considerable falls are met with. The land rises steadily, until, about 400 miles above Yambuga, the river is contracted into a rushing stream about 100 yards wide, banked by the steep walls of cañon, the slopes and summits of which are clothed with wood. Whatever changes the face of the land may show, the forest covers peak, hill, ridge, valley, plain: everywhere it is continuous, never broken, except at such clearings as man has made. Mr. Stanley very graphically compares the country traversed by his expedition to the long glacis of a fort rising from the Kongo to a height of from 5,000 to 6,000 feet. Down the slope flows the Aruvimi, one of whose feeders runs almost within sight of Albert Nyanza, to which there is a sudden drop of 2,900 feet.

The main Ituri, at the distance of 680 miles from its mouth, is 125 yards wide, 9 feet deep, and has a current of 3 knots. It appears to run parallel with the Nyanza. Near that group of cones and hills, affectionately named Mount Schweinfurth, Mount Junker, and Mount Speke, Stanley would place its highest source.

rich grass-lands begin, about eighty miles from Albert Nyanza, is another point deserving special attention, and can only be explained when we have accurate observations of the rainfall and other conditions that go to form climate.

The character of the forest is entirely different from the open woods, with scanty underwood, of the more southerly parts of Africa. According to Stanley's description, they resemble in character the South American forests. Stanley says: "Take a thick, Scottish copse, dripping with rain; imagine this copse to be a mere undergrowth, nourished under the impenetrable shade of ancient trees ranging from 100 to 180 feet high; briars and thorns abundant; lazy creeks meandering through the depths of the jungle, and sometimes a deep affluent of a great river. Imagine this forest and jungle in all stages of decay and growth, — old trees falling, leaning perilously over, fallen prostrate; ants and insects of all kinds, sizes, and colors murmuring around, monkeys and chimpanzees above, queer noises of birds and animals, crashes in the jungle as troops of elephants rush away; dwarfs with poisoned arrows securely hidden behind some buttress or in some dark recess; strong brown-bodied aborigines with terribly sharp spears, standing poised, still as dead stumps; rain pattering down on you every other day in the year; an impure atmosphere, with its dread consequences, fever and dysentery; gloom throughout the day, and darkness almost palpable throughout the night: and then, if you will imagine such a forest extending the entire distance from Plymouth to Peterhead, you will have a fair idea of some of the inconveniences en-

duced by us from June 28 to Dec. 5, 1887, and from June 1, 1888, to the present date, to continue again from the present date till about Dec. 10, 1888, when I hope then to say a last farewell to the Kongo forest."

Mr. Stanley's description of the daily course of things in the forest region is worth quoting: "The mornings generally were stern and sombre, the sky covered with lowering and heavy clouds; at other times thick mist buried every thing, clearing off about 9 A.M., sometimes not till 11 A.M. Nothing stirs then: insect-life is still asleep; the forest is still as death; the dark river, darkened by lofty walls of thick forest and vegetation, is silent as a grave; our heart-throbs seem almost clamorous, and our inmost thoughts loud. If no rain follows this darkness, the sun appears from behind the cloudy masses, the mist disappears, life awakens up before its brilliancy. Butterflies scurry through the air, a solitary ibis croaks an alarm, a diver flies across the stream, the forest is full of a strange murmur, and somewhere up river booms the alarum drum. The quick-sighted natives have seen us, voices vociferate challenges, there is a flash of spears, and hostile passions are aroused."

Stanley does not give very detailed information regarding the tribes met with, except the statement that five different languages are spoken. He says that Negambi Rapids, about two hundred and fifty miles above the junction of the Aruvimi and the Kongo marks the division between two different kinds of architecture and language. Below, the cone-huts are to be found; above the rapids we have villages, long and straight, of detached square huts surrounded by tall logs, which form separate courts, and add materially to the strength of the village. Many precautions had to be adopted against attacks by poisoned arrows. Mr. Stanley lost several men by these arrows, and Lieut. Stairs had a narrow escape. It was afterwards found that the poison is manufactured from the dried bodies of red ants or pismires ground into powder, cooked in palm-oil, and smeared over the wooden points of the arrows. As might have been expected, the forest is haunted by myriads of insects of every variety.

THE INFLUENCE OF CERTAIN DRUGS ON PHYSICAL STRENGTH AND ENDURANCE.

T. FREDERICK PEARSE, M.D., in an article in *Knowledge*, says that certain drugs have a great reputation for increasing physical endurance. These are chiefly coca, caffeine, and kola-nut; and there are certain other chemical compounds of analogous composition which are derived from muscular tissue, and have been found experimentally to have a similar effect. These are chiefly creatine and hypoxanthine. The chemical relation of all these substances is very interesting. Strange to say, some are themselves the products of muscular waste. It will be noticed, also, that creatine and hypoxanthine occur in beef-tea, which is so well known as a general restorative and as a nervous stimulant, and there is ample experimental proof that it assists muscular power. The chemical relationship of the alkaloids found in tea, coffee, kola, and coca to the products of muscle-tissue metamorphosis suggests that these products are either replaced in the muscular tissue by these drugs, or that the products act on the nervous system either as a food or as a stimulant, and are merely supplemented in their action by the drugs. It is a very interesting question whether these alkaloids act locally on the muscle substance or upon the central nervous system.

As we know that tea, coffee, cocoa, and beef-tea sustain and strengthen the nervous energies when they have been exhausted by other than prolonged muscular action, the inference is that these substances, as well as the analogous products of muscular tissue, act also directly as food or stimulant to the nervous centres. Dr. Pearse has tested and found by experiment the powers of caffeine in increasing the respirations, and in strengthening as well as increasing the rapidity of the heart's action.

The following statements have been made by different writers as to the value of these substances. Of coca, *Markham's Peruvian Bark* says it enables a greater amount of fatigue to be borne with less nourishment, and it lessens the difficulty of respiration in ascending mountain-sides. *The Practitioner* says, "The leaves

are chewed to appease hunger and support strength in the absence of food, and used generally for the stimulant and narcotic effects of tobacco and alcohol;" *The Lancet*, "It is of use to steady nerves of excitable persons (to a sportsman in shooting, for example), to give endurance; it is used by travellers in Bolivia and Peru to counteract the effect of rarefied air on mountains." Lauder Brunton writes, "In small doses it is said to lessen fatigue and enable the Indians in Peru to make long marches, and a similar result has been obtained in trials upon soldiers in Germany." Experimentally, coca appears to act in small doses as a stimulant to the nervous system, affecting first of all the cerebral hemispheres, next the medulla, and lastly the spinal cord. It lessens the feeling of fatigue, but the only mental effect seems to be an exhilaration of spirits. Like caffeine, it increases the rapidity of the heart-beat, and raises the blood-pressure.

Experimentally, caffeine has been found, in small doses, to quicken the respiration and also the pulse. It seems to affect the accelerating centre directly, as its action is equally well defined after the nerves have been divided. Besides increasing the rapidity of the heart's action, it seems also to strengthen it, and it raises the blood-pressure. Caffeine also seems to lessen tissue change and waste. In addition, caffeine appears to have some power in paralyzing the conducting power of the sensory parts of the spinal cord, and it may be in this way that it relieves the sense of fatigue. At the same time, however, it is found to increase generally the functional activity of the spinal cord. H. C. Wood says, "The peculiar wakefulness, the increased mental activity, and the often nervous restlessness which are induced by strong coffee are familiar to almost every one. By doses of two or three grains of caffeine, a very similar state of the body is induced. The increase of brain-power which has been noticed by various observers after caffeine, as well as after coffee, tea, guarana, and all the allied crude drugs, is undoubtedly real, and must be due to a direct stimulant action on the cerebrum. It appears to me that the cerebral stimulation of caffeine differs from that of opium, in that it affects the reasoning faculties at least as profoundly as it does the imagination. Coffee prepares for active work both mental and physical; opium, rather for the reveries and dreams of the poets. The enormous use made by mankind of substances containing caffeine indicates that in some way it is directly of service in the wear and tear of life."

The nuts from the kola-tree (*Sterculia acuminata*), a native of tropical Africa, are used to support the strength, allay the appetite, assuage thirst, and assist the digestion. They have also a reputation for increasing the capacity to bear prolonged fatigue. The kola-nuts contain a large percentage of the same chemical principle, theine, as is contained in tea and coffee. They also contain an aromatic volatile oil, to which some of their properties must be attributed. The seeds have been employed as a remedy for drunkenness, and they are said to abate the drink-crave. By virtue of the alkaloids, caffeine and theobromine, contained in kola, it must act as a cardiac tonic, improving both the force and rhythm of the heart. The kola-nut is slightly bitter and astringent, and its reputed value in digestive disturbances and diarrhoea may be based on these properties.

Of all inorganic compounds, the phosphates seem perhaps of the greatest importance in animal tissues. They are found in considerable quantity in the human body wherever active cell-growth is going on. They must be ranked among the most valuable and necessary foods. Their acknowledged value in disorders of the nutritive system of children, and also in convalescence from acute as well as wasting diseases, in all of which rapid growth and tissue development is taking place, is good ground for the practical inference that they are intimately concerned in nutrition generally, and especially in the recuperation of parts worn out by disease. The recovery from prolonged and severe exertion also may very probably be assisted by them. The compounds of the meta-, pyro-, and hypo-phosphates, in which the element phosphorus is loosely combined, seem much more efficacious than the ordinary salt. According to Ashburnton Thompson, repeated doses of phosphates improve the appetite, increase the rate of the circulation, sharpen the mental faculties, increase the muscular power, and give a sensation of well-being.

Creatine and hypoxanthine are said, in small doses, to have the power of increasing muscular work, and to cause the muscle to recover rapidly after exertion. Creatine particularly is said to have this power to a great extent. Glycogen is also classed with these substances, and is said to have great power of increasing muscular capability.

In practice, however, we all recognize a difference in the action of the popular mixtures, — tea, coffee, cocoa, etc. In many persons tea will stimulate, and in a few it exercises a marked action on the kidneys and bladder. Coffee, again, will keep some people awake, while tea does not have the same effect with them. With some individuals it acts as a mild aperient. Coca does not seem to have any decided action on the digestive organs or kidneys.

We find, therefore, that the reputation for sustaining the strength, appeasing hunger, and temporarily increasing the physical powers, which coca, kola, coffee, and tea have in the respective parts of the world in which they are indigenous, is borne out by experiment. Moreover, there seems a probability that physiological science will shortly be able to provide a satisfactory explanation of the practical value of these substances.

BOOK-REVIEWS.

Francis Bacon, his Life and Philosophy. By JOHN NICHOL. Part II. Bacon's Philosophy. Edinburgh, Blackwood. 16°. (Philadelphia, Lippincott, \$1.25.)

THIS is the latest issue in Messrs. Blackwood's series of Philosophical Classics. In the first part of the work, Professor Nichol gave an account of the life of Bacon, and in this he gives an exposition of his philosophy. He first recounts the efforts of previous thinkers, ancient and modern, to solve the physical problems of the universe, and shows how most of them failed, owing to neglect of observation and experiment, which we now know to be the most essential means of discovering physical truth. He points out, however, that before the appearance of Bacon's works the right method had come into use, and Copernicus, Kepler, Galileo, and others had made important discoveries by the use of it. Hence Bacon cannot be credited with discovering the new method, but only with being the first to generalize it and give a philosophical theory of it. He shows, as others have done, that Bacon recognized more or less clearly the various experimental methods now acknowledged by logicians, while at the same time he pointed out the defects in the induction of the ancients. Bacon also made a survey and classification of the sciences, which has not even yet lost all its interest, and which at the time it was written was quite remarkable. Bacon must also be credited, notwithstanding the defects in his moral character, with an earnest desire to serve his fellow-men, "believing," as he says of himself, "that I was born for the service of mankind." Such being his merits and such his purposes, it is important to inquire why it was that his own attempts to discover the secrets of nature resulted in nothing but failure. Professor Nichol discusses this question at considerable length, and expresses the opinion that Bacon failed partly because he had too overweening a sense of the power of his method, and partly because he thought the universe a far simpler thing than it really is; and he quotes Bacon's own remark, that he "should presently disclose and bring into sight all that is most hidden and secret in the world," as showing what extravagant expectations he had. But the main reason for Bacon's failure was that in his own researches he was seeking for something that does not exist. His object was to find the "forms" of things, and there has been some difficulty in ascertaining what he meant by this term. He certainly did not mean causes, and the true view is doubtless that expressed by Mill in his "Logic," and adopted by Professor Nichol. The "forms" were something "related to permanent qualities as efficient causes are to changes or events." Or, as Mill says, Bacon "seems to have thought, that, as every event has an invariable antecedent, so every property of an object has an invariable co-existent, which he called its form." But, as both Mill and Professor Nichol remark, there is no such invariable co-existent of each property of a thing; and hence Bacon, in his search after "forms," was pursuing *ignes fatui* with the usual result of landing in a bog. The failure of his own researches, however, should not blind us to his real contribu-

tions to the theory of method; and what these contributions were Professor Nichol has pointed out in the pages of this interesting work.

Curve Pictures of London for the Social Reformer. By ALEX. B. MACDOWALL, M.A. London, Sampson Low. 16°.

THIS little book is intended by its author to represent, in a pictorial form, such statistics and other information as are necessary for the social reformer in his efforts to deal with the great problems which he has undertaken to help to solve. Like the leader of an army setting out on a campaign, those who are bent on doing something to right the wrongness of our social state (especially through legislation) should see clearly what *is*, while cherishing an ideal to be realized. To furnish such a guide has been the author's endeavor. Diagrams are given by which one can ascertain for a series of years the following: population; density of population; birth, marriage, and death rates; early marriages; death by disease; suicides; drunkenness; felonies; licensed houses; apprehension; pauperism; education; illiteracy; prices of commodities and prices of meat.

Marriage and Divorce in the United States. By D. CONVERS. Philadelphia, Lippincott. 16°. \$1.25.

THE author of this work is a clergyman, and writes from a high-church point of view. He starts out with the remark that "marriage and divorce in the United States are in an unsatisfactory condition," and then goes on to criticize our marriage laws in detail. He calls attention to the looseness of these laws in some of the States, and to the difficulties often arising from the difference in legal requirements in different States. He strongly condemns the common-law doctrine of marriage, according to which all that is necessary to constitute a valid marriage is a mutual declaration by the two contracting parties that they take each other as husband and wife, followed by cohabitation; although he is obliged to admit that this is and always has been the canon law of the Christian church. He condemns marriage with a deceased wife's sister, which he declares to be incest. On the subject of divorce he takes the extreme scriptural ground, holding to the principle "once married, married till death." He would allow separation in case of fornication, but without liberty to marry again; while absolute divorce, such as the law now grants, he considers an abomination. He gives some tables and charts showing the rates of marriage and divorce in the different States of the Union, which will be useful to students of the subject, and also many interesting examples to illustrate the defects and inconsistencies in our marriage laws. The fault of his work is, of course, the extreme view he takes of the indissolubility of the marriage tie, — a view which the mass of men will not accept, and which it is impossible to embody in legislation. Our marriage and divorce laws need reforming, but the work must be done in a sensible and practical way, and not in a spirit of hide-bound conservatism.

AMONG THE PUBLISHERS.

IN the *Fortnightly Review* for April (New York, Leonard Scott Publication Company, 29 Park Row), Sir Charles Dilke presents the second of his series on the frontiers of India. These papers, while partly military, are largely made up of descriptions of places seldom visited by Europeans. H. H. Johnston discusses the question "Are our Foreign Missions a Success?" from the point of view of the political economist, and finds their indirect influence in matters of education and enlightenment of positive value. W. M. Gattie tells of some scandals of the English lighthouse boards. Professor J. R. Seeley's address on ethics and religion before the Ethical Society of Cambridge is printed in full. Arsene Houssaye, probably the only living survivor of the poet's friends, contributes the first section of a delightfully gossipy paper on Alfred de Musset. Mr. W. H. Mallock joins the agnostic controversy with a paper entitled "Cowardly Agnosticism," in which he points out a number of startling facts. Two papers from opposite standpoints treat of the enfranchisement of women, by Miss Fawcett and Stuart Glennie, which are especially timely in view of the fact that two bills are now before Parliament giving the suffrage to women.

Professor Dowden writes a scholarly and instructive paper on Edmond Scherer, the French poet and critic, who died in March.

— We regret to note that failing mental faculties have at last compelled Mr. George Bancroft, the historian, to abandon his literary labors.

— It is almost a year since *Scribner's Magazine* began the publication of its Railway Series; and the publishers now announce that in the June number they will begin a series of popular articles on the practical applications of electricity. Among the writers who have been already secured are Professor Cyrus F. Brackett of

Princeton College, who will write a general introduction to the series; Charles L. Buckingham, chief electrical engineer of the Western Union Telegraph Company; President Henry Morton of Stevens Institute of Technology; A. E. Kennelly, chief electrical expert of Mr. Edison's laboratory; Dr. M. Allen Starr, a medical investigator of high position; Lieut. W. S. Hughes of the United States Navy; and Lieut. John Millis of the United States Army. Among the subjects of the articles will be "The Application of Electricity to Modern Telegraphy, to Lighting, to the Household, to the Human Body, to Warfare on Land and Sea, and to Large Industries." The whole series will be illustrated.

Publications received at Editor's Office,

April 8-13.

- ALDEN'S *Manifold Cyclopaedia of Knowledge and Language*. Vol. XII. Dominis to Electric Clock. New York, J. B. Alden. 12^s. 50 cents.
- AMERICAN Workman. The. Vol. I, No. 1. New York, M. Dunham. 16 p. 4^s. \$2.50 per year.
- ANDREWS, Thomas, the Scientific Papers of the Late; with a Memoir by P. G. Tait and A. Crum Brown. London and New York, Macmillan. 514 p. 8^s. \$5.
- BENNETT, A. M., and MURRAY, G. A Handbook of Cryptogamic Botany. London and New York, Longmans, Green, & Co. 473 p. 12^s. 85.
- CHORAL Book, The, for Home, School, and Church. Tr. by Friedrich Zimmann and Edwin L. Kirkland. Boston, Ginn, 95 p. 8^s. 50 cents.
- DEIGHTON, K. Shakespeare's the Winter's Tale. London and New York, Macmillan. 106 p. 60 cents.
- DUPUIS, N. F. Elementary Synthetic Geometry of the Point, Line, and Circle in the Plane. London and New York, Macmillan. 294 p. 16^s. \$1.10.
- GRAVER and PALETTE. Vol. I, No. 1. New York. Graver & Palette Publ. Co. 8 p. 1^s. 50 cents per year.
- HAMILTON, D. J. A Text-Book of Pathology, Systematic and Practical. London and New York, Macmillan. 736 p. 8^s. \$6.25.
- HORN Gymnastics for the Well and the Sick. Ed. by E. Angerstein, M.D., and G. Eckerl. Tr. from 8th German ed. Boston and New York, Houghton, Mifflin, & Co. 99 p. 8^s.
- HOMER'S Odyssey. Books I-IV. Ed. by B. Perrin. Boston, Ginn. 229 p. 12^s. \$1.50.
- JERRAM, C. S. Grace Reddenda. Oxford, Clarendon Pr. 100 p. 16^s. (New York, Macmillan, 60 cents.)
- LEFFMANN, H., and BEAM, W. Examination of Water for Sanitary and Technical Purposes. Philadelphia, Blakiston. 106 p. \$1.25.
- LONGMANS' New Atlas, Political and Physical. Ed. by Geo. G. Chisholm. London and New York, Longmans, Green, & Co. 4^s. \$4.
- MAC DOWALL, A. B. Curve Pictures of London for the Social Reformer. London, Sampson Low. 49 p. 16^s.
- MACKNIGHT, J. A. Hagar. New York, Chicago, and San Francisco, Belford, Clarke, & Co. 321 p. 16^s.
- OIL and Gas, the Journal of. Vol. I, No. 1. New York, G. H. E. Woods. 8 p. 8^s. \$2 per year.
- PROCTOR, R. A. The Student's Atlas. In Twelve Circular Maps. London and New York, Longmans, Green, & Co. 213 p. \$1.50.
- RAIN-FALL, Report of in Washington Territory, Oregon, California, etc., for from Two to Forty Years. Washington, Government. 101 p. 8^s.
- SCOTT'S Rokeby: a Poem in Six Cantos. Ed. by Michael Macmillan. London and New York, Macmillan. 280 p. 16^s. 90 cents.
- SMITH, R. H. Graphics; or, The Art of Calculation by drawing Lines, applied especially to Mechanical Engineering. With an Atlas of Diagrams. Part I. London and New York, Longmans, Green, & Co. 8^s. 85.
- STERLE, J. D. Hygienic Physiology with Special Reference to the Use of Alcoholic Drinks and Narcotics. New York and Chicago, A. S. Barnes & Co. 401 p. 12^s. \$1.

A BOOK FOR THE TIMES!

NEW EDITIONS!

Laidlaw's Constitution of the United States and the Declaration of Independence, in English, French, and German, with notes. Sold by all booksellers, or by the publishers, LAIDLAW BROS. AND CO., 137 W. 41st St., New York.

Second and Revised Edition, in cloth 50c. postpaid.

Third Edition, in paper 25c. postpaid.

A NEW MAGAZINE—THE SWISS

Devoted to spreading a love of nature among the people. Edited by HARRIS H. B. LADD, President of the Agassiz Association, and succeeding *St. Nicholas* as the official magazine of that body. \$1.50 a year. Sample copy 10 cents, or 25 cents for trial subscription for 3 months. N. D. C. HODGES, PUBLISHER, 47 Lafayette Place, New York. Mention this paper.

MACMILLAN & CO.'S NEW BOOKS.

Nature Series. New Volumes.

POPULAR LECTURES AND ADDRESSES ON VARIOUS SUBJECTS IN PHYSICAL SCIENCE. By Sir William Thomson, D.O.L., LL.D., F.R.S.E., Professor of Natural Philosophy in the University of Glasgow. With Illustrations. Vol. I., Constitution of Matter. 12mo, \$2.

We do not believe that any man of science will rise from the perusal of these papers without a deepening or a shattering of old convictions, and without broader and clearer views of the possibilities of future scientific progress. . . . We await the appearance of the second and third volumes of these papers with great interest.—*Nation*.

THE CHEMISTRY OF PHOTOGRAPHY. By Raphael Meldola, F.R.S., &c. Professor of Chemistry in the Finsbury Technical College. 12mo, \$2.

MODERN VIEWS OF ELECTRICITY. By Oliver J. Lodge, LL.D., D.Sc., F.R.S., Professor of Experimental Physics in University College, Liverpool. Illustrated. *In Press*.

ELEMENTARY TEXT-BOOK OF ZOOLOGY. By Dr. C. Claus. Translated and Edited by Adam Sedgwick, M.A., F.R.S., with the assistance of F. G. Heathcote, M.A. 2d edition. Vol. I., General Part and Special Parta Protozoa to Insecta. With 491 Woodcuts. Vol. II., Special Part: Mollusca to Man. With 215 Woodcuts. 2 Vols. 8vo, \$8.

TALES OF THE BIRDS. By W. Warde Fowler, M.A., Sub-Rector of Lincoln College, Oxford. Illustrated. 12mo, \$2.50.

Mr. Fowler has produced a charming book which none are so old and few so young to appreciate. He possesses the rare art of telling a story simply and unadornedly. . . . The Tales of the Birds would be an admirable present to any child, and if the grown-up read it first the present would, in a peculiar degree, confer the double blessing which proverbially belongs to a gift.—*Guardian*.

PRINCIPLES OF EMPIRICAL OR INDUCTIVE LOGIC. By John Venn, sc.D. F.R.S. Fellow and Lecturer in the Moral Sciences, Gonville and Caius College, Cambridge. Author of "The Logic of Chance," "Symbolic Logic," &c. 8vo, \$4.50.

MACMILLAN & CO., 112 FOURTH AVENUE, NEW YORK

SCRIBNER'S MAGAZINE
FOR MAY CONTAINS.

THE LAND OF THE WINAHIE is the first of the **FISHING ARTICLES**, which will be followed by papers on **STRIPED BASS** and **TARPON** fishing. Dr. Leroy M. Yale and J. G. Aylwin Croighton write of the Lake St. John Region north of Quebec, Canada, where the land-locked salmon is abundant. Superbly illustrated.

THE FREIGHT-CAR SERVICE, by Mr. Theodore Voorhes, describes the manifold system which keeps it in motion. With many interesting illustrations.

PHOTOGRAPHY. An absorbingly interesting article on the wonders of photography, by Prof. John Trowbridge. A list of the illustrations indicates the value of the paper:

- Photograph of hand taken by its own light.
- by lamp light, 20 seconds exposure.
- of an unstained plate.
- of same showing value of colors.
- of burning building taken by its own light.
- of surf higher than house.
- of human eye, contracted pupil.
- dilated pupil.
- of same through a film hole.
- of maple tree showing colors.
- of field of lightning.
- of successive attitudes of a man throwing stone.
- of frog taken under water.
- of human speech.
- of surf at Hastings, England.

TOLSTOY 20 YEARS AGO. Mr. Eugene Schuyler gives in this paper, which will be included next month, his personal reminiscences of Tolstoy, with many conversations now first published. Illustrated by many interesting portraits.

SHORT STORIES AND PAPERS include "The Dilemma of Sir Guy the Neuter," by Octave Thanet; the second and concluding part of "Jeanne," by J. E. Curran; "Fiction as a Literary Form," by Hamilton W. Mabie; and a new chapter of Robert Louis Stevenson's stirring serial "The Master of Ballantrae."

THE LACK OF OLD HOMES in America, by Charles Eliot Norton, forms a charming end paper this month.
25 Cents a Number; \$3.00 a Year.
CHARLES SCRIBNER'S SONS, NEW YORK.

—D. C. Heath & Co. of Boston have in preparation an "Industrial and Educational System of Drawing," by Langdon S. Thompson, A.M., recently professor of the subject in Purdue University, and now supervisor of drawing in the schools of Jersey City.

— "Washington's Letter to Benjamin Harrison," governor of Virginia in 1784, on the Potomac navigation scheme and the general question of the opening of the West, has just been added by the directors of the Old South studies in history to their new general series of Old South Leaflets. They have also added Washington's circular letter to the governors of the States, on disbanding the army in 1783,— a letter which Washington himself felt to be so important that he termed it his "legacy" to the American people, and which discusses the political problems of the time so seriously and thoroughly that it should be read everywhere to-day along with the farewell address. The "Farewell Address" (No. 4), and the "First Inaugural," April 30, 1789 (No. 10), have already appeared in this series.

— In the *Atlantic Monthly* for May is a paper on "Temperance Legislation, its Uses and Limits," written by Charles Worcester Clark. Mr. Fiske contributes one of his historical papers on "Brandywine, Germantown, and Saratoga." Mr. W. H. Bishop writes a graphic sketch of "The Paris Exposition in Dishabille," giving its appearance when the buildings were just being completed. He also describes the Eiffel Tower, the great landmark of the exhibition. An amusing article on "The Philosophy and Poetry of Tears" is contributed by J. T. L. Preston; Mr. Frank Gaylord Cook writes about "The Lawyer in National Politics," and reminiscences of famous "Trotting Horses" are given by H. C. Merwin. Josiah Royce contributes the first of two papers on "Reflections after a Wandering Life in Australasia;" another paper of a lighter kind, also having to do with travel, is "At Sesenheim," by Bliss Gerry. Sesenheim is the place, not far from Strasbourg, where Goethe wooed, won, and ran away from Freiderike.

— G. P. Putnam's Sons add to their announcements "The Ideals of the Republic, or, Great Words from Great Americans," comprising the Declaration of Independence, the Constitution of the United States, Washington's First Inaugural, Washington's Second Inaugural, Washington's Farewell Address, Lincoln's First Inaugural, Lincoln's Second Inaugural, Lincoln's Gettysburg Address. The volume will contain etched portraits of Washington and Lincoln, and will be issued as No. 20 of the Knickerbocker Nuggets. They will also publish a translation of Dante's "Convito," by Katharine Hillard; a third volume in Mr. Pfyfe's series of works on pronunciation, entitled "Seven Thousand Words often Mispronounced;" and "An Essay on Money," by James Platt, author of "Business," reprinted, under arrangement with the author, from the nineteenth English edition. For the American Historical Association they will issue a "Report of the Proceedings at the Fifth Annual Meeting held in Washington in December, 1888." For the American Society of Church History they will publish Vol. I. of its papers, comprising "The Progress of Religious Freedom as Illustrated in the Toleration Edicts," by Philip Schaff, D.D., president of the society; "Indulgences in Spain," by Henry C. Lea, LL.D.; "The Crisis in the Middle Ages," by James Clement Moffat, D.D.; "Melancthon's Synergism, a Study in the History of Psychological Dogmatism," by Frank Hugh Foster; "The Influence of the Golden Legend," by Professor E. C. Richardson; and "Notes on Syncretism," by Professor Hugh McDonald Scott.

— Ward, Lock, & Co. have just ready "The Life and Opinions of John Bright," by Francis Watt, fully illustrated. They will publish at once "Camps and Quarters," a series of military sketches and stories by the well-known war correspondents, Archibald Forbes, George Henty, and Charles Williams.

— Houghton, Mifflin, & Co. will shortly publish "The War for Independence," by John Fiske, which will form the first volume of a new series to be entitled *The Riverside Library for Young People*. This series is intended for boys and girls who are laying the foundation of libraries of their own, and will contain history, mechanics, travel, adventure, natural history, and the best class of fiction. Other volumes announced for this series are "Birds through an Opera-Glass," by Florence A. Merriam; a biography of George

Washington, by Horace E. Scudder; and "Up and Down the Brooks," by Mary E. Bamford.

— Harper & Brothers have just issued another volume in the series of English Classics for School Reading, "Fairy Tales in Prose and Verse," selected from early and recent literature, and edited, with notes, by William J. Rolfe. The book is fully illustrated.

— D. Appleton & Co. have ready a revised edition of their "Dictionary of New York." It will be found a comprehensive guide not only to the historic and curious sights, but to the practical as well, such as hotels, the streets, the best modes of travel, restaurants, places of amusement, etc.

— Hubbard Brothers, Philadelphia, have in press an illustrated volume to be entitled "Living Leaders of the World." It will contain short biographies of men and women now most prominent all over the world. The portraits, mostly from new photographs, to accompany these biographies, will be in steel plate, photography, and woodcut. Many well-known authors are engaged upon the biographies.

— Theodore Voorhees, assistant general superintendent of the New York Central, will contribute to the *May Scribner's* one of the articles in the Railway Series, explaining the complicated machinery which is necessary to carry on the enormous freight-car service of the country. The fishing article, on "The Land of the Winanish," will be illustrated from sketches and drawings by Dr. Leroy M. Yale, and L. R. O'Brien, president of the Canadian Academy. The advances in photography which have been made possible by the dry-plate process will be treated by Professor John Trowbridge of Harvard, who will illustrate some unique results by photographs taken under most peculiar conditions, as under water, by lamp and candle lights, and by lightning-flashes.

— D. C. Heath & Co. of Boston have ready for immediate publication, in their series of Science Guides, "Thirty-Six Observation Lessons on Common Minerals," by Henry Lincoln Clapp, master of the George Putnam Grammar School, Boston. It is not an epitome of any work on mineralogy, nor simply a collection of suggestions, but a specific, practical guide for the use of the teacher. By following its plan, the teacher becomes simply a director of the pupils' energies, thus cultivating the scientific habit of thinking and working.

— The Hon. Mrs. Maxwell-Scott of Abbotsford is preparing for publication some hitherto unpublished journals of her great-grandfather, Sir Walter Scott.

LETTERS TO THE EDITOR.

*.*Correspondents are requested to be as brief as possible. The writer's name is in all cases required as proof of good faith.

The editor will be glad to publish any queries consonant with the character of the journal.

Twenty copies of the number containing his communication will be furnished free to any correspondent on request.

New Sources of Heat.

UNDER the above heading, Mr. Lorin Blodget of Philadelphia writes to *Bradstreet's*, making several assertions as to the possibility of obtaining heat from air without the use of much carbonaceous fuel, so that it seems worth while to have the known facts in the case ventilated in the columns of *Science*. Will not some of your correspondents show us in how far Mr. Blodget may be right?

Quoting from Mr. Blodget, "in the course of the many improvements and adaptations found necessary to attain the best calorific results, and especially in the use of solid fuels for metallurgic purposes, it is certain that there is a great accession of heat from other sources than the ordinary yield from coal burned. In all cases where a powerful blast is applied to the limited area of a melting furnace, and particularly in the Bessemer converter, the degree of heat generated is greatly in excess of the theoretical yield of the number of pounds of coal consumed.

"The power of any incandescent surface to intensify the heat evolved by simply intensifying the blast is well known in many processes, but such surfaces have not been supposed to constitute a

source of heat distinct from that derived from carbonaceous combustion. It is known that the result is cumulative, but it has not been known that there was another source, in the heat evolved from the air itself. Incandescence of the non-combustible concretion, or crystallization forming the Welsbach hood or burner, is known to be a prolific source of heat as well as of light. And there are many evidences that incombustible materials of like refractory character may and do yield heat largely when incandescent under an air-blast; the presence of carbon, and the normal consumption of carbon and oxygen, not being essential or even attendant conditions.

"As a result of experiments for some years conducted, leading in this direction, and in the earlier part of this period confined to the use of an air-blast with a very small adjunct of hydro-carbon gas, the most intense metallurgic heat was produced without the use of any solid or liquid fuel, and without the production of gases as the products of combustion, in any form of carbonic acid or carbonic oxide. The very small proportions of carbonaceous gas—hydro-carbon gas—used as the means of setting the air-blast on fire not being sufficient to cause delivery of carbonic acid or oxide from the flue, no flue was used, in fact, as an upward delivery, and none was necessary.

"These trials were but steps, however, leading to a more complete substitution of atmospheric combustion by contact with incandescent surfaces, carbonaceous at first, and of anthracite or bituminous coal, the carbon of which would remain intact after hours of evolution of intense heat. The conditions of such contact are still obscure as to the point of original action or the cause of such action; but it is demonstrated that the utmost intensity of heat, not less than 4,000°, can be and is attained with a mere initiative of carbonaceous combustion, and, when once established, may be maintained for an indefinite period by merely preserving

the incandescence of the surface. And this may be done by a slight manipulation of the surface brought to incandescence, and with some slight renewal of carbonaceous material.

"The direction of these results is so clear that it is assumed to be a new and practicable method of the evolution of heat for economic purposes. The air itself, which is the only body consumed, becomes a new source of heat, acting independently of the supposed limit of oxygenization or of carbonaceous combustion. Nor is any gaseous or aeriferous compound delivered as the product of such evolution of heat or combustion, if so called. We have applied the term 'combustion' heretofore to all combinations resulting in the evolution of heat enough to burn or disorganize organic matter.

"If the air itself, its nitrogen as well as its oxygen, can be made available as a direct source of heat without the attendant conditions of the formation of waste products, such as carbonic acid or carbonic oxide, the discovery is one of the greatest in human experience. It implies the substitution of an inexpensive natural fuel for the expensive natural and artificial now in use. The mere suggestion appears too great to be credible; but it is absolutely true that this is done experimentally with complete success, and that appliances are already in use, heating the air in large buildings, and melting the most refractory metals in considerable quantities. The intensity of the heat is equal to that of the blow-pipe, while the extent of space to which it is applied is adequate to any requirement for steam-generation or for manipulation of iron or other metals.

"It is only intended here to cite so much of what are admitted facts in heat-production by the usual processes as will show that other and superior aids to heat-production are already reached in many cases, and that the line of reasonable progress lies in the direction of relief from dependence on the combustion of carbon, organic or inorganic, as the source of heat for economic purposes."

X.

ONE LANGUAGE FOR THE WHOLE WORLD.

WORLD-ENGLISH :

THE UNIVERSAL LANGUAGE. 25 CENTS.

EVERY one has heard of the butcher who, after a long search for his knife, at last found it in his mouth; so speakers of English have been seeking for a universal language, when, lo! it is in their mouths. The intelligibility of English words has been obscured by a dense mist of letters. This is now dispersed by A. Meville Bell, who has already won a world-wide reputation through his invention of "Visible Speech," the great boon to deaf-mutes. Professor Bell calls this new discovery of his "World-English," and the result is a language which cannot fail to meet with acceptance, and at once supersede the supposed necessity for "Volapük," or any other artificial language. No language could be invented for international use that would surpass English in grammatical simplicity, and in general fitness to become the tongue of the world. It is already the mother-tongue of increasing millions in both hemispheres, and some knowledge of the language is demanded by all educated populations on the globe. Social and commercial necessities require that the acquisition of this knowledge shall be facilitated, and it is believed that Professor Bell's invention has removed the last impediment to English becoming the universal language, for which vague desires have long been entertained, although hitherto only futile efforts have been made.

Ex-President Andrew D. White, of Cornell University, says: "I believe that the highest interests of Christian civilization and of humanity would be served by its adoption. China and Japan would be made English-speaking peoples within fifty years, and so brought within the range of Christianizing and civilizing ideas, in the largest sense. All existing missionary work is trivial as compared with this. For your system would throw wide open those vast countries, as, indeed, all the countries of the world, to the whole current of English and American thought."

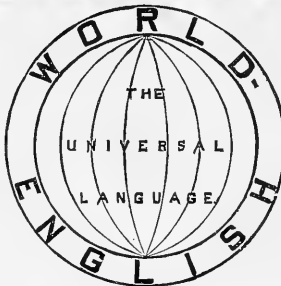

For Diffusion of English throughout the World

THE UNIVERSAL LANGUAGE

This "Hand-Book of World-English" is the Complete, Simple, and Efficient Medium.

FOREIGNERS

Will Acquire, by Means of this Hand-Book, a
PERFECT PRONUNCIATION OF ENGLISH.
For Primary School Pupils and Illiterate Adults

World-English is a Royal Road to Reading,
To Teachers of English and Modern Languages

This Hand-Book will be of Primary Importance
as a Phonetic Directory.

DEFECTS OF SPEECH

Will be Readily Corrected by Means of the Articulative Directives in this Hand-Book.

HAND-BOOK OF WORLD-ENGLISH,

25 CENTS.

The plan of this little book is altogether new. Letters and sounds are so associated, in all the exercises, that from the mere knowledge of letters a learner cannot fail to pronounce words with certainty. English reading will thus be easily acquired, whether by natives or foreigners, children or adults.

The general resemblance of World-English to Literary English is such that any reader of the latter decides the former at sight, or, at most, after a few minutes' study of the new letters. A like result may be anticipated for those who shall learn to read from World-English. They will transfer their power of reading to the literary form of the language, almost without effort. The orthographic aspect of words will, besides, be so fixed in the eye, by contrast, that spelling will be remembered as — what it really is — a pictorial association with words.

No special training is required to qualify teachers for using this book. The subject can even be successfully introduced in the kindergarten and the nursery. This phonetic mode of initiation in reading cannot be too strongly urged on the attention of School Boards on both sides of the Atlantic.

The ordinary orthography of each word is interlined with the World-English version throughout the Exercises and Readings.

So set down, our tongue is the best for the world to unite upon.—*Brooklyn Eagle*.

The idea of Mr. Bell has much to recommend it, and the presentation is charmingly clear.—*American*, Phila. The result is a language which cannot fail to meet with acceptance.—*Boston Traveller*.

Has the merit of great ingenuity.—*Railway Age*.

His treatise, as a study of English orthoepy, condenses the result of much thought and experience in small compass.—*The Critic*.

World-English deserves the careful consideration of all serious scholars.—*Modern Language Notes*.

World-English is the English language unburdened of its chaotic spelling.—*Popular Science Monthly*.

We commend it to the attention of teachers.—*Ottawa Globe*.

"World-English" and "Hand-Book of World-English" can be had of all booksellers, or will be sent for 50 cents, post free, by the publisher.

N. D. C. HODGES, 47 Lafayette Place, New York.

GUARANTY INVESTMENT COMPANY

CAPITAL \$250,000.

Offices: Atchison, Kan. 191 Broadway, New York. 222 Walnut St., Phila.

Hon. ALBERT H. HORTON (Chief Justice, Kansas Supreme Court), Topeka, Kan., Pres't.

7% Guaranteed Farm Mortgages 7%

The Guaranty Investment Company makes loans upon fertile farms in the choicest portions of Kansas and Nebraska and has adopted the policy of sending a Committee of its Investors each year to examine its loans and methods of business.

The Committee this year consisted of PROF. A. H. BERLIN, Principal of the High School Montrose, Pa., and MAJ. J. THEODORE L. POOLE, Ex-U. S. Pension Agent, Syracuse, N. Y. Both of these gentlemen are persons of the highest character and have the confidence of the Communities in which they reside.

The Committee has recently returned and has made a very interesting Report upon the general development of Kansas and Nebraska as well as the business of the Company. The Company will be glad to send this Report to any address.

The following names are taken from the long list of Investors in our Mortgages:

(See if Some Friend of Yours is not in the List.)

William A. Cauldwell, 59 Liberty St., N.Y.
 Palmer Cox, 658 Broadway, N.Y.
 Rev. Jos. H. Kylanec, D.D., 11 Livingston Place, N.Y.
 Rev. Brady E. Backus, D.D., 360 West 28th St., N.Y.
 Rev. R. M. Sommerville, 126 West 45th St., N.Y.
 Dr. Robert A. Murray, 235 West 23d St., N.Y.
 Dr. James P. Tuttle, 136 West 41st St., N.Y.
 H. Edwards Rowland, 218 Fulton St., N.Y.
 Irving H. Tift, Esq., 271 Broadway, N.Y.
 Prof. D. G. Eaton, 55 Pineapple St., Brooklyn, N.Y.
 Dr. E. P. Thwing, 136 St. Marks Ave., Brooklyn, N.Y.
 Dr. C. C. Miles, Greenport, N.Y.
 John V. N. Bergen, Port Jefferson, N.Y.
 Benj. W. Sulwell, Yonkers N.Y.

R. C. Coleman, Goshen, N.Y.
 Mrs. Samuel Carlisle, Newburg, N.Y.
 Dr. C. C. Bartholomew, Ogdensburg, N.Y.
 Rev. Nelson Millard, D.D., Rochester, N.Y.
 Rev. Horace G. Hinsdale, D.D., Princeton, N.J.
 Dr. Charles M. Howe, Passaic, N.J.
 George A. Skinner, 5 Railroad Place, Newark, N.J.
 Dr. Edwin M. Howe, 85 Halsey St., Newark, N.J.
 Dr. H. G. Buckingham, Clayton, N.J.
 Dr. Martin Cole, Jr., Hainesville, N.J.
 Mortgage Trust Co. of Pa., Philadelphia, Pa.
 Miss Mary Miller, 1230 Spruce St., Philadelphia, Pa.
 Henry D. Biddle, 312 1/2 Walnut St., Philadelphia, Pa.

Dr. Calvin C. Halsey, Montrose, Pa.
 Rev. William Baldwin, Great Bend, Pa.
 Gen. William Lilly, Mauch Chunk, Pa.
 Second Nat. Bank, Mauch Chunk, Pa.
 Enos E. Thatcher, West Chester, Pa.
 Mrs. Townsend Poore, Scranton, Pa.
 Rev. Burdett Hart, D.D., New Haven, Conn.
 Dr. Frank H. Wheeler, New Haven, Conn.
 Charles R. Christy, Stamford, Conn.
 Mrs. Catharine P. Fuller, Woodmont, Conn.
 Miss Jessie Henderson, Lenox, Mass.
 Dr. M. J. Halloran, Worcester, Mass.
 Albert Walker, Bennington, Vt.

Address for Report and Monthly Bulletin

HENRY A. RILEY, General Eastern Manager, 191 Broadway, N.Y.

The Mutual Life Insurance Company

OF NEW YORK.

RICHARD A. McCURDY, PRESIDENT.

ASSETS - - - \$126,082,153 56

The Largest and best Life Insurance Company in the World.

The New Business of the Mutual Life Insurance Company in 1888

Exceeded \$103,000,000.

Its Business shows the Greatest Comparative Gain made by any Company during the past year including

A gain in assets of.....	\$ 7,275,301 68
A gain in income of.....	3,096,010 06
A gain in new premiums of.....	2,333,406 00
A gain in surplus of.....	1,645,622 11
A gain in new business of.....	33,756,792 85
A gain of risks in force.....	54,496,251 85

The Mutual Life Insurance Company

Has Paid to Policy-holders since Organization \$272,481,839 82.

Wants.

A YOUNG MAN can have lucrative engagement, not only a fixed salary, but according to his work accomplished in travelling for SCIENCE. A personal interview invited.

N. D. C. HODGES,

47 Lafayette Place, New York.



KIMBALL'S
 STRAIGHT CUT
 CIGARETTES.

Unsurpassed in quality.
 Used by people of refined taste.
 Highest award at Brussels, 1888.
 The finest smoking mixtures are of our manufacture.
 Fifteen First Prize Medals.
 W. M. S. KIMBALL & CO.
 Rochester, N.Y.

"The Week, one of the ablest papers on the continent." —Descriptive America.

ENLARGED AND IMPROVED.

THE WEEK :

A Canadian Journal of Politics, Literature, Science and Arts.

PUBLISHED EVERY FRIDAY.

\$3.00 per Year.

\$1.00 for Four Months.

THE WEEK has entered on its SIXTH year of publication, greatly enlarged and improved in every respect, rendering it still more worthy the cordial support of every one interested in the maintenance of a first-class literary journal.

The independence in politics and criticism which has characterized THE WEEK ever since its first issue will be rigidly maintained; and unceasing efforts will be made to improve its literary character and increase its value and attractiveness as a journal for the cultured home. Many new and able writers are now, or have promised to become, contributors to its columns, and the constant aim of the Publisher will be to make THE WEEK fully equal to the best literary journals in Britain and the United States.

As heretofore, PROF. GOLDWIN SMITH will, from time to time, contribute articles. London, Paris, Washington and Montreal letters from accomplished correspondents will appear as regular intervals. Special Ottawa Letters will appear during the sessions of Parliament.

THE WEEK in its enlarged form will be the same size as "Harpers Weekly," and the largest paper of its class on the continent.

SEND FOR FREE SAMPLE COPY.

C. BLACKETT ROBINSON, Publisher,
 5 Jordan St., Toronto.

Readers of Science

Corresponding with or visiting Advertisers, will confer a great favor by mentioning this paper.

Schools.

The Sauveur Summer College OF LANGUAGES.

(Removed from Amherst, Mass., and Oswego, N.Y., to BURLINGTON, VT.)

The Normal Class will be taught for the French by Dr. Sauveur, for the German by Dr. W. Bernhardt, for the Latin by Prof. J. U. Dillard. Fourteenth Session: July 8 to August 16.

Dr. Sauveur's new work, LES CHAN-ON'S DE BERANGER, with Historical Commentary and Notes, will be ready June 1, and taught at the School. For Circulars address

DR. L. SAUVEUR,

Copley Terrace, Roxbury, Boston, Mass.

N.B.—Circulars of Dr. L. SAUVEUR Educational Works will be sent free to applicants. (Mention this paper.)

CONNECTICUT, NEW HAVEN.

MRS. CADY'S SCHOOL FOR YOUNG LADIES. Prepares for Smith and Wellesley, and admits to Vassar by Certificate. Circulars. Early application necessary.

INDIANA, TERRE HAUTE.

ROSE POLYTECHNIC INSTITUTE.—A School of Engineering. Well endowed, well equipped departments of Mechanical and Civil Engineering. Electricity, Chemistry, Drawing. Extensive Shops & Laboratories. Expenses low. For catalogue address T. C. Mendenhall, Pres.

NEW JERSEY, PLAINFIELD.

THE CHESTNUTS.—Parents with daughters to educate, or orphan girls with companion, may find a comfortable home, with school instruction by applying to Miss E. E. Kenyon.

Any one who will have the following blank filled out by a responsible Newsdealer, and mailed to us, will be allowed a three months' subscription to Science.

N. D. C. HODGES,

47 LAFAYETTE PLACE, NEW YORK.

1889.

To the _____ News Company.

You may add to my regular order five copies of SCIENCE each week (returnable).

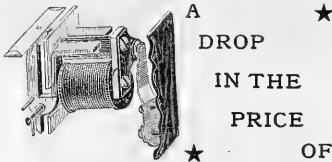

GRAVITY DROP ANNUNCIATORS.

DON'T FORGET THE

DUST-PROOF BELLS.

HAZAZER & STANLEY, 32 Frankfort Street, N. Y.

SCIENCE CLUBBING RATES.

Table with columns: 10% DISCOUNT, Year's Subscription, With Science, With The Swiss Cross. Lists various publications and their rates.



JOHN HASTINGS = A=R=HART = JOS=TRIPP. Pres. Gen. Manager. V. Pres.

ENGRAVING FOR ALL ILLUSTRATIVE AND ADVERTISING PURPOSES

BRANCH AT 728 CHESTNUT ST. PHILADELPHIA, PA.

67-71 PARK PLACE, NEW YORK.

N. D. C. HODGES, 47 Lafayette Place, New York.

C. & C. ELECTRIC MOTOR COMPANY.

Electric Motors
 FOR
**Arc and Incandescent Cir-
 cuits, Most Economical
 Motor on the
 Market.**
Regulation Perfect.
**Motors Designed for all
 Power Purposes.**

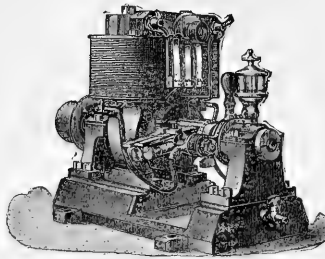

OFFICE and MANUFACTORY:
 402 and 404 Greenwich Street, New
 York City.
New England Office, 19 Pearl St., Boston.
Philadelphia Office, 301 Arch St.
**Western Office, 139-141 Adams Street
 Chicago.**
**Southern Office, 25 Carondelet Street,
 New Orleans.**

OUR CENTENNIAL EXHIBIT.

Many of those who regularly read advertisements of our goods in these columns, will be in New York city during Centennial Week. We hope to see them here in the store. For a few days, immediately preceding and following the great Military and Civic Parades, each department in the house will make a special decorative display of its goods. Having, beyond question, one of the largest and most varied assortments of High Novelty Dress Fabrics to be found in America, we expect to make this Exhibit memorable, and in every way worthy of the time in which it occurs.

JAMES McCREERY & CO.
 BROADWAY AND ELEVENTH STREET,
 NEW YORK.

A TEMPORARY BINDER
 for *Science* is now ready, and will be mailed postpaid on receipt of price.



Half Morocco - 75 cents.
 This binder is strong, durable and elegant, has gilt side-title, and allows the opening of the pages perfectly flat. Any number can be taken out or replaced without disturbing the others, and the papers are not mutilated for subsequent permanent binding. Filled in this binder, *Science* is always convenient for reference.
N. D. C. HODGES,
 47 Lafayette Place, N. Y.

Old and Rare Books.
A. S. CLARK, Bookseller,
 34 PARK ROW, NEW YORK CITY.
 A Gleaner in the By-ways of Literature. Results of Gleaning found in Catalogues issued from time to time.
CATALOGUE NO. 27 NOW READY.
BACK NUMBERS and complete sets of leading Magazines. *Notes for.* AM. MAG. EXCHANGE, Schoharie, N.Y.
H. WILLIAMS,
 Dealer in Old Magazines, Reviews, &c. Scientific periodicals a speciality. 39 Macdougal St., N.Y.

Scientific Apparatus.

J. GRUNOW,

621 Sixth Avenue, New York.
 Established 1852.

MAKER OF

Microscope Stands,
 Oil Immersion Objectives and Abbe Condensers for Bacterial and Histological work, of Objectives, Camera Lucida and other accessory apparatus.

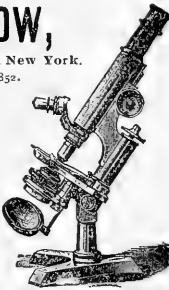

IMPROVED OIL LIGHT MAGIC LANTERNS.

Also *Lime and Electric Light Apparatus,* and mechanical, plain, and fine colored views.
J. B. COLT & CO., Manufacturers,
 No. 16 BEEKMAN STREET, NEW YORK.

MAGIC LANTERNS Stereopticons and the Best Views for Public, Church, Home, and Scientific Exhibitions. Best apparatus, new views. Largest stock. Reduced prices. 24 Years' Practical Experience. Illus. Catalogue Free.
GEO. H. PIERCE,
 136 S. Eleventh St., Philadelphia, Pa.

ELECTRICAL TESTING BUREAU,

Johns Hopkins University, Baltimore, Md.
 Resistance Coils and Boxes Compared.
 Am meters and Volt meters calibrated.
 Condensers standardized.
 Primary and Secondary Batteries Tested.
 Efficiency of Dynamoes and Motors Determined.
 Insulation of Cables and Wires Tested.
 Etc., Etc.
 Circulars describing Methods Used, Prices, Etc., sent on Application.
 Address as above.

MORRIS EARLE & CO.
 SUCCESSORS TO
K. & J. BECK,
 1016 Chestnut Street Phila

Microscopes and all Accessories and Apparatus. Photographic and Photo-Micrographic Apparatus and Outfits.
 Spectacles, Eye Glasses, Opera and Marine Glasses, etc.
 Illustrated Price List mailed free to any address. Mention *SCIENCE* in corresponding with us.



E. & H. T. ANTHONY & CO.
 537 Broadway, N.Y.
 Manufacturers and Importers of **PHOTOGRAPHIC INSTRUMENTS.** Apparatus and Supplies of every description. Sole proprietors of the Patent Detective, Fairy, Novel, and Bicycle Cameras, and the Celebrated Stanley Dry Plates.
 Amateur Outfits in great variety, from \$5.00 upward. Send for Catalogue or call and examine. **More than 40 years established in this line of business.**



GOOD NEWS TO LADIES.

Greatest inducements ever offered. Now's your time to get up orders for our celebrated **Teas and Coffees,** and secure a beautiful Gold Band or Moss Rose China Tea Set, Dinner Set, Gold Band Snow Rose Toilet Set, Watch, Brass Lamp, or Webster's Dictionary. For full particulars address **THE GREAT AMERICAN TEA CO.,** P. O. Box 289, 81 and 83 Vesey St., New York.

R. ELLIS & CO.

BUSINESS, HOTEL AND PATENT BROKERS,
AUCTIONEERS, ETC.
No. 176 BROADWAY,
Room 46. New York.

CLIENTS Advised free of charge.

THE GREAT FOUR TRACK ROUTE, NEW YORK CENTRAL & HUDSON RIVER RAILROAD.



All Trains arrive at and depart from the Grand Central Station, New York; the largest and finest Railway Station in America, and the only Trunk Line station in the city of New York.

Run regularly to and from New York and Boston and make direct connection to and from

BUFFALO, CLEVELAND, ST. PAUL, TEXAS,
 NIAGARA FALLS, CINCINNATI, MANITOBA, DENVER,
 TORONTO, INDIANAPOLIS, PORTLAND, SALT LAKE,
 DETROIT, CHICAGO, ST. LOUIS, KANSAS CITY,
 SAN FRANCISCO, etc.

For Time Tables or information call on nearest Ticket Agent of the Boston and Albany, New York Central, Lake Shore and Michigan Southern, Michigan Central, "Bee Line," or address

M. C. ROACH,

Gen'l Eastern Passenger Agent,
 No. 413 Broadway, New York City.

E. J. RICHARDS, Ass't Gen'l Passenger Agent,

GRAND CENTRAL STATION.

The Route of the "Fast Mail" and the Famous Vestibuled "New York, Chicago, and St. Louis Limited."

Two of the four tracks are devoted exclusively to Passenger Trains. This, in connection with the easy grades, light curves and superior construction, makes the New York Central and Hudson River Railroad THE SAFEST, QUICKEST, AND MOST COMFORTABLE ROUTE BETWEEN NEW YORK OR BOSTON AND THE WEST.

The Niagara Falls Route

Is over the New York Central & Hudson River Railroad in connection with the Michigan Central Railroad, crossing Niagara River on the celebrated Cantilever Bridge within a few hundred yards of the falls. All trains stop ten minutes at Falls View Station at the verge of the great cataract and in full view of the rapids just above the falls.

**MAGNIFICENT
 New Wagner
 Sleeping Cars.**

The Great
 4 TRACK
 Route



The "Highlands of the Hudson River," as seen from the trains of the New York Central.

GEORGE H. DANIELS, Gen'l Passenger Agent,

PARIS EXPOSITION.

The Cheque Bank issues Cheques, either singly or put up in books, for the special use of VISITORS to the PARIS EXPOSITION, who can cash the same at upwards of seventy Banking Houses, situated in different parts of Paris, without charge.

Visitors' mail matter can be addressed to them, Care of the Societe Generale, 4 Place de l'Opera, opposite the Grand Hotel, where English is spoken.

Every Cheque that is issued by the Cheque Bank is EQUAL TO CASH, as Bank Notes are, for the Bank's Capital, Guarantee Fund and Customers' Balances are invested in British Government Securities, or held in Cash in the Bank of England, and can be cashed in every town in Europe without charge.

For Handbook containing list of 2,500 Banking Houses who cash the cheques, free of charge, apply to

CHEQUE BANK, Limited,
 Capital, £100,000. Guarantee Fund, £27,000.
 Trustees, The Right Honourable John Bright, M.P.,
 The Right Honourable Earl Beauchamp.
NO. 2 WALL STREET, NEW YORK.

Visitors to Europe and Paris Exposition should carry a book containing Cheque Bank Cheques, which are absolutely safe and cheaper than Letters of Credit, and much more convenient; are payable on presentation without charge at 2,500 Banking Houses and 250 of the principal Hotels in Europe.

FOOD ADULTERATION

And its Detection. With photomicrographic plates and a bibliographical appendix. By J. P. Battershall, 328 pages, 8vo, cloth. Price, \$3.50. Circulars and Catalogues on application. E. & F. N. SPON,

12 Cortlandt St., New York.

Readers of Science

Corresponding with or visiting Advertisers will confer a great favor by mentioning the paper.

Arnold,
 Constable & Co.
 INDIA PONGEES,
 CORAHS.

Great novelty of style and color is to be found in these fabrics. Unsurpassed for durability and wear. Late importations are now being opened.

Broadway & 19th st.
 New York.

IMPROVING
 THE
MEMORY PICK

and facilitating the acquirement of knowledge by lectures and correspondence. Classes forming. "MEMORY and its Doctors," from Simonides to "Loisette," mailed for 10 cents.

DR. PICK, 24 Union Square, N. Y. City.

PATENTS.

During April and May my fees due only on allowance if desired. Write

W. H. BARCOCK,
 513 Seventh St., Washington, D. C., P. O. Box 220.
 Formerly Examiner in Patent Office.
 THIRTEEN YEARS' PRACTICE.

KNABE

PIANOFORTES.

UNEQUALLED IN

Tone, Touch, Workmanship and Durability.

WILLIAM KNABE & CO.

NEW YORK: No. 112 Fifth Av., above 16th St.
 BALTIMORE: Nos. 22 and 24 E. Baltimore St.
 WASHINGTON: No. 817 Market Space, Penn. Av., near 9th St.

SCOTT'S EMULSION

Is acknowledged by Physicians to be the FINEST and BEST preparation of its class for the relief of CONSUMPTION, SCROFULA, GENERAL DEBILITY, WASTING DISEASES OF CHILDREN, and CHRONIC COUGHS. ALL DRUGGISTS. Scott & Bowne, New York.

133807
MAY 6 1889

SCIENCE

N. A. MASON LIBRARY
300 NORTH 4TH STREET
PHILADELPHIA, PA.

[Entered at the Post-Office of New York, N. Y., as Second-Class Matter.]

A WEEKLY NEWSPAPER OF ALL THE ARTS AND SCIENCES.

SEVENTH YEAR.
VOL. XIII. No. 326.

NEW YORK, MAY 3, 1889.

SINGLE COPIES, TEN CENTS.
\$3.50 PER YEAR, IN ADVANCE.

STORAGE-BATTERIES FOR STREET-CARS.

THE last car which the Julien Electric Traction Company put into actual passenger service (Car No. 7), and which is the standard type of car that they have finally adopted, is making five round trips per day between 86th Street and Madison Avenue and the Post Office, or 57½ miles daily. This is a car-day's work on that line. They claim a saving per year in favor of the Julien system,

Car No. 1, on the Fourth Avenue line, commenced service on Sept. 3, and on April 8 the batteries were examined for the first time. They had not in this period been lifted from the cells to be cleaned or inspected. It is claimed that they were found to be in as good condition as when they were put in service; not a single plate in the whole battery showing any wear, injury, or depreciation.

At one time it was thought that the handling of the batteries in

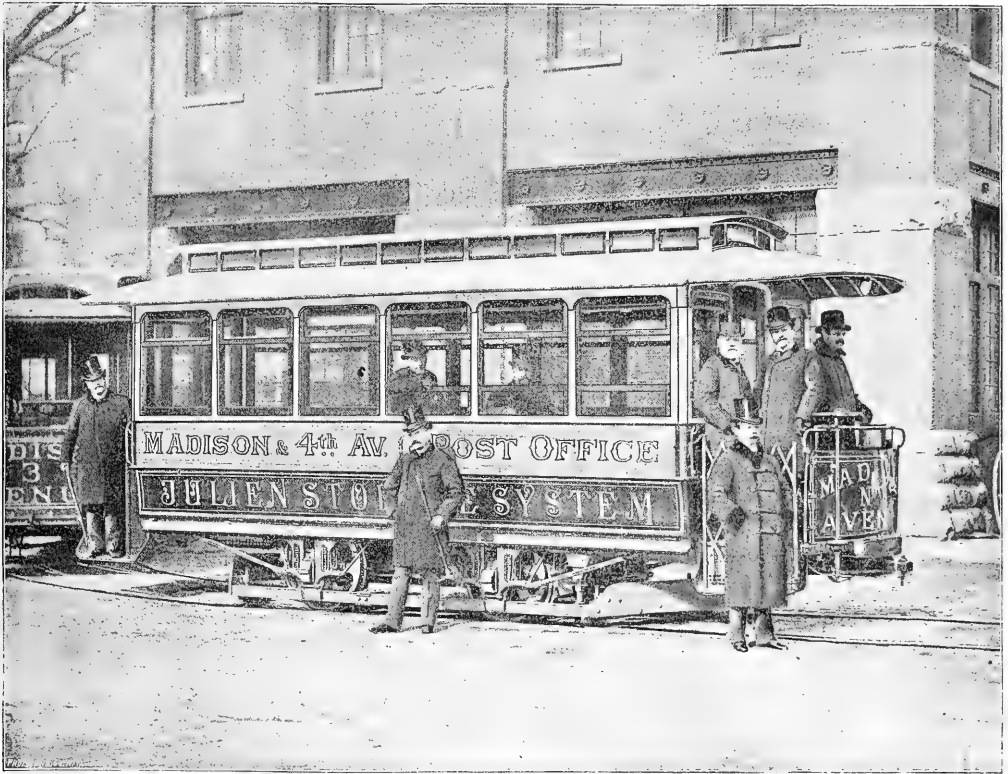

STREET-CAR DRIVEN BY JULIEN STORAGE-BATTERIES.

on each car, as compared with horse-cars, of \$2,719.25, and that the net earnings will more than pay the entire cost of the car and its equipment at the end of the first year. During the time (forty days) the car has been in operation, neither the batteries nor the motors have required attention or the expenditure of one dollar for repairs or renewals. Even the brushes, it is claimed, have not been changed, nor do they show any wear.

this system of traction would be a serious obstacle; but this company has now a battery-shifting device, whereby, in the length of a car-body, and on either side of the pit over which the car stands in the station, sufficient batteries are stored and manipulated to do the work of one hundred and thirty-five horses. The racks which contain the batteries, and the hoists, which are run by two small stationary motors, do not, in all, cover as many cubic feet as two

sixteen-foot cars. By aid of this device the batteries are changed in less than three minutes. In actual time, less than five minutes are required to inspect the car thoroughly and change the battery.

A feature of this system is, that a street-railway need no longer have its own generating machinery, as must be the case with cables, overhead wires, and conduit systems. In every town and city where there is a central lighting-station, power for charging the batteries, it is stated, may be purchased for about two cents per horse-power; so that the plant of the system will be reduced to the devices of one battery-rack, as above described, for each set of fifteen cars, and switch-boards for governing the distribution of the current.

The cost of motive power for a car-day of 60 miles, the company estimate at \$3.10. By motive power, they mean cost of energy at two cents per horse-power, and \$700 per annum for maintenance of batteries and motor. These figures, they claim, are the result of their present experience. To those who may think two cents per horse-power a low estimate, they say that they have offers from electric companies to furnish power at that figure.

scratch or dull when touched. The varnish is mainly intended, of course, for "ivory" film negatives, and for this purpose nothing can be better. It will not crack or soften; dust, water, and foreign matter will not adhere to it; and retouching is facilitated by its use.

THE JULL SNOW-EXCAVATOR.

In December last the Jull Snow-Excavator Company sent out a preliminary circular, calling the attention of railroad officials to the fact that its snow-excavator was in course of construction, under recent patents of Mr. Orange Jull of Ontario, Canada. Since then the excavator has been completed, and submitted to three severe tests on the Rome, Watertown, and Ogdensburg Railroad at Oswego, N.Y.

On March 6, 1889, the excavator cleared seven hundred and fifty feet of track, covered with hard frozen snow varying in depth from two to seven feet. The snow was thrown a distance of sixty feet. This was a particularly severe test, by reason of the fact that the snow had been lying upon the siding during the entire winter, and

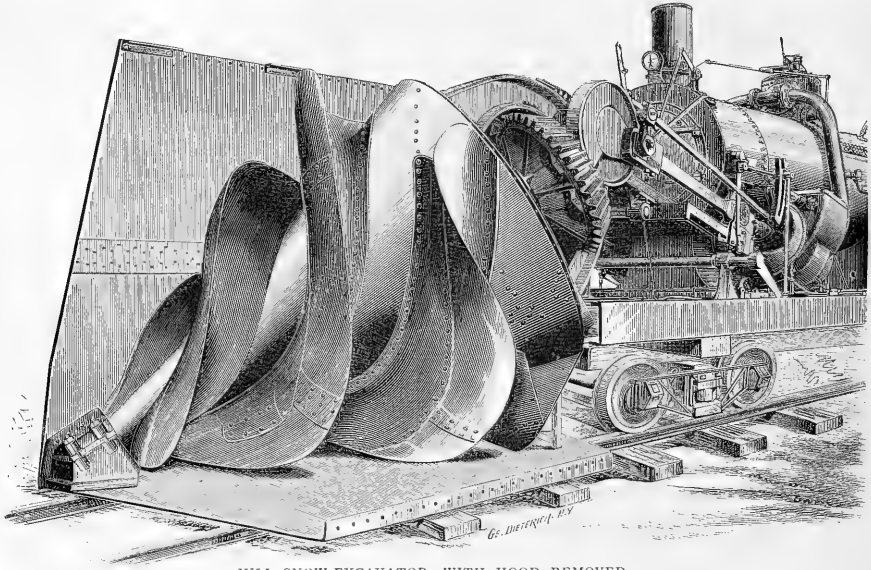

JULL SNOW-EXCAVATOR, WITH HOOD REMOVED.

The new cars, thirty of which are now under construction by the Stephenson Company, will weigh but a fraction over six tons; or, in other words, but little more than the cars of the overhead system.

IVORY VARNISH.

A NEW medium for protecting glass negatives and positives from injury by dampness, friction, or moist printing-paper, has recently been introduced under the name of "ivory varnish," according to *The Photographic Times*; and, so far as experiments with it have progressed, it seems to be an excellent and safe compound. As it dissolves pyroxiline, however, it cannot be used for collodion plates; but it is perfectly applicable to gelatine negatives. The latter need not even be heated when the varnish is applied, but the preparation is merely flowed over their surface and dried in an ordinary temperature. The result is a protective film of extreme hardness, which perfectly resists the action of all moisture. A negative thus varnished, after being thoroughly dried, may be immersed in hot water of 120° F., and wiped dry with a rag, without injury. This quality makes the "ivory varnish" an excellent one for transferred bromide prints. The damar varnish heretofore used for this purpose, being softened by a high temperature, will

was nearly as hard as solid ice. Some of the pieces of ice thrown out were afterwards weighed, and one was found which weighed seventy-five pounds.

On March 9, 1889, the excavator cleared a siding upward of nine hundred feet in length, filled with hard snow varying in depth from two to eight feet. The time consumed was not taken on either of the above occasions; but the excavator worked steadily, and without any stoppage whatever.

On March 11, 1889, the third exhibition was made at Oswego. This demonstration was witnessed by representatives of the Rome, Watertown, and Ogdensburg Railroad, the Lehigh Valley Railroad, and the Pennsylvania Railroad. In this case the excavator was timed, and exact measurements taken, by the railroad officials present, of the length of the cut, and depth of snow. The length of the cut was 720 feet; average depth of snow, 7 feet, varying in depth from 18 inches to 10 feet or more; the width of space cleared was 10 feet. This cut was cleared of snow, and the rails left clean, without the use of flangers, in seven minutes time. The motive power was furnished by two passenger-locomotives, one with a cylinder 16 by 22, and the other 17 by 24. The number of revolutions of the bladed cone did not exceed 180 per minute, although its capacity exceeds 300 revolutions per minute. Thus it

will be observed that there were cleared in seven minutes, 50,400 cubic feet of snow, or 7,300 cubic feet per minute. It was estimated by one of the railroad officials present that it would have taken roomen an entire day to accomplish what was done in seven minutes.

The accompanying illustrations, taken from photographs, show the cardinal principles of the device, yet a brief mention of some of its distinctive features may not be out of place.

the blades of the cone itself. Thus the snow is sliced off and discharged in one operation, by means of a single mechanism, the absolute simplicity of which is considered a valuable feature.

3. It is impossible, the company claims, to choke the hood or blades of the cone with snow. It always comes out of the snow absolutely clean, with its blades free from snow.

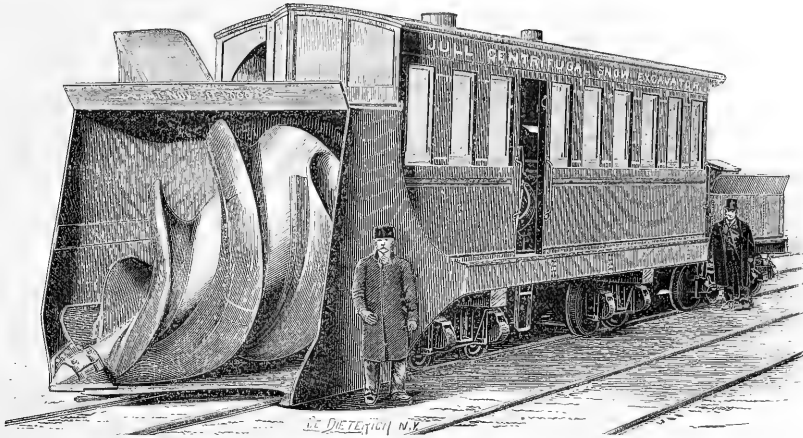

JULL SNOW-EXCAVATOR.

1. The diagonal arrangement of the bladed cone, so that its apex is at the lower right-hand corner of the hood, while the base is at the upper left-hand corner, is one of its distinctive and important features. By this arrangement the curved blades of the cone operate directly upon and slice off the face of the snow-bank, from side to side of the hood, without any direct resistance whatsoever, except that of the straight sides of the hood.

4. The power to operate the bladed cone is supplied by an 800-horse-power boiler, containing 220 2-inch flues. The engines consist of two 18 by 24 cylinders.

5. The snow may be thrown to either or both sides of the track without reversing, and, in fact, changed from one to the other without stopping. To quote from the *Engineering News* of March 30, 1889, "there is no double direction of revolution, no

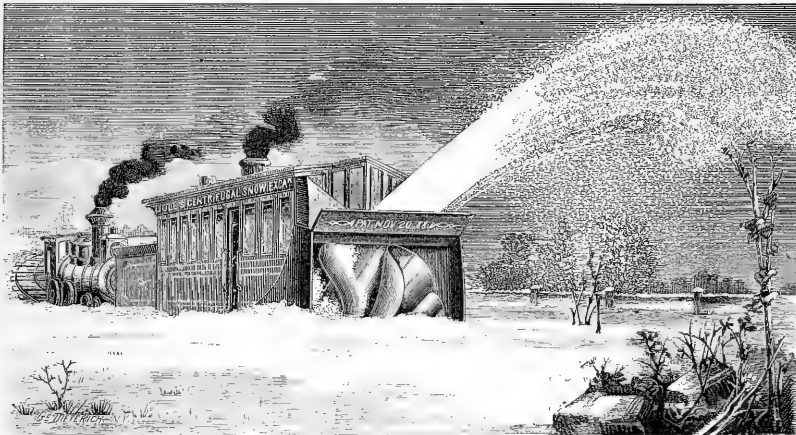

JULL SNOW-EXCAVATOR IN OPERATION.

2. The curvature of the blades is much greater toward the apex of the cone than toward its base, so that in their first contact with the snow the blades operate as an augur. As the velocity of the cone in its revolutions increases toward its base, by reason of its increasing diameter, the centrifugal force generated is correspondingly increased; so that the snow gathered in by the curved blades is thrown out without the necessity of fan-blades, other than

reversion of knives, and no closed box to hold snow, back of the mechanism which first attacks it."

The Jull Manufacturing Company (Brooklyn, N.Y.), of which Mr. George H. Hobart is president, solicit an investigation concerning the merits of their excavator, and state that the centrifugal excavator is also adapted to clear railroad-tracks which have been blockaded by sand.

IMPROVED STEAM APPARATUS FOR HEATING AND VENTILATING.

THE house of B. F. Sturtevant, Boston, Mass., has just brought out a new design of its steam hot-blast apparatus, which is now well known. This apparatus, first placed upon the market a quarter of a century ago, has been gradually improved and rapidly introduced, until about 5,500 are now in use for various purposes.

The apparatus is a practical embodiment of the principle that a positive circulation of air is necessary to secure rapid and perfect ventilation, heating, or drying. Although constructed in a great variety of styles, to suit all conditions and requirements, it always combines the essential elements,—a fan and a heater. It is furthermore usually constructed with an engine directly connected to the fan-shaft, as shown in Fig. 1. The fan is designed espe-

space connecting with the drips. By this time it has condensed, and leaves the heater in the form of water of condensation.

The sides of these heads are planed and fitted, and joints made by copper gaskets; so that, when drawn together by the through bolts, there is no possibility of leakage. In connection with the sections is bolted on, at one end of the group, a header for steam inlet (*A*), and drip (*B*). Both of these are large, and allow of the use of exhaust steam without placing back pressure upon the engine. The pipes *C* and *D* are respectively exhaust-steam inlet and drip, communicating with the outermost section, which has no head, and is entirely independent of the remainder of the group. It is designed to utilize the exhaust from the fan-engine. The head end of each section rests upon the wrought-angle-iron foundation of the heater, while the opposite ends are supported by cast-iron balls (*E*) so as to allow for expansion.

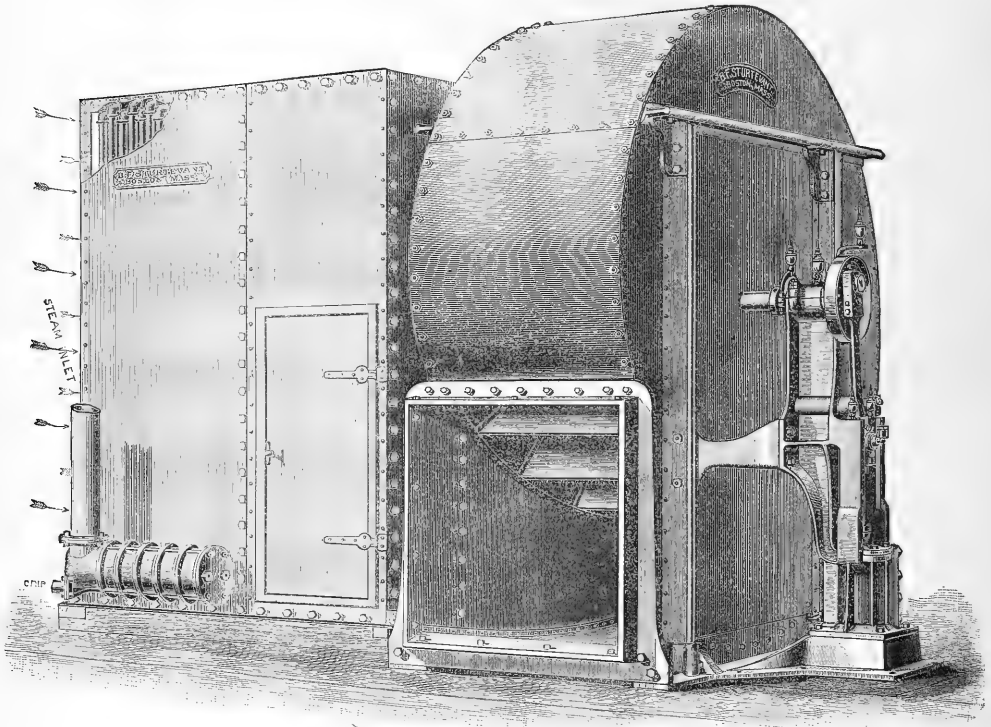

FIG. 1.

cially for handling large volumes of air with a minimum expenditure of power. The advantage of a special engine, for the sole purpose of driving the fan, is evident. The fan may then be run at any time and speed, independent of any other source of power. The engines are of Mr. Sturtevant's design and construction, and are equal to the trying duty of fan-propulsion and continuous running.

Radical changes have been recently made in the heater. As now constructed, the heater proper consists of a series of hollow sectional bases, shown clearly in Figs. 2 and 3. Their sides are corrugated so as to fit closely together and allow of no alternate expansion and contraction of the air passing between the pipes. At one end of each section is a circular head (see Fig. 2) divided horizontally by a diaphragm, so that the upper portion is in communication with the steam inlet, and the lower with the drip. Steam, admitted at the left through the steam inlet, passes up the series of pipes, through the horizontal pipes, and down into the

After continued use of wrought-iron pipe, Mr. Sturtevant has adopted steel. The adoption of steel pipe marks one of the great improvements in these heaters. The heater is incased in a fire-proof steel-plate jacket communicating with the inlet to the fan, so that air is drawn by the fan equally across all parts of the heater. The pipes in the sections being set staggering, the air is compelled to take a tortuous course, and is brought into intimate contact with every foot of pipe.

In operation for heating and ventilating, the outlet of the fan is connected with a system of ducts or pipes leading to the various parts of the building. In the case of an ordinary manufactory either the distribution takes place through galvanized-iron piping, in the form of upright mains extending to the various floors, and having one or more outlets near the ceiling on each floor, or in other cases horizontal mains extend the entire length of the building just under the ceiling on each floor, and the air is discharged through outlets in these. In schoolhouses, churches, theatres, etc.

the air is generally conveyed through flues built into the interior walls; the volume and rate of discharge being governed by the register through which the air escapes.

The object always is to discharge the air either at or towards the cold outer wall, but it must be admitted that it takes a great deal of experience in this line to enable any one to lay out a perfect working system.

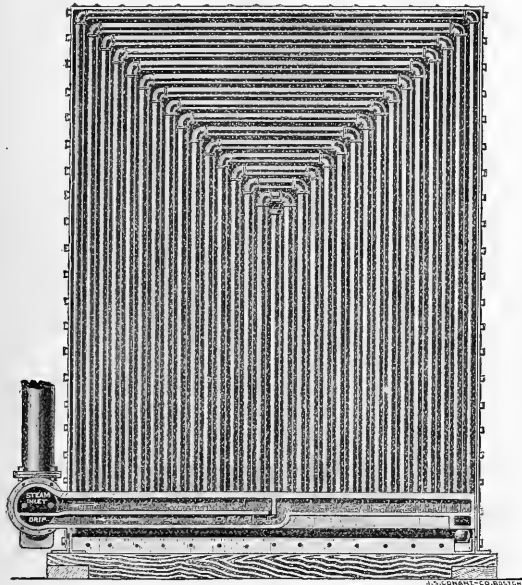

FIG. 2.

This system, known as the "blower system," possesses many advantages. Above all, it is positive. The air, being forced into the building, must of necessity thoroughly circulate through it, creating perfect distribution of heat, and ample ventilation. The source of supply of the air introduced being always under control, there can be no opportunity for the presence of injurious impurities. In any system dependent upon natural agencies to produce venti-

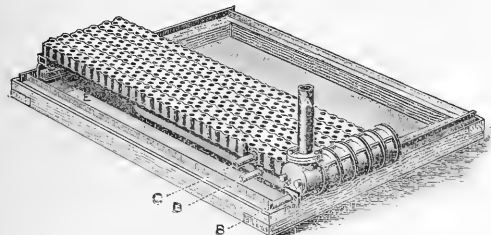

FIG. 3.

lation, changes in the weather always have a serious, and in some cases a perfectly nullifying effect. With mechanical ventilation, this can never occur, for the pressure produced by the fan is far in excess of that due to any changes in the atmosphere.

In the blower system, a marked saving is made in the amount of heating-surface required. The large amount of air passing through the heater causes such a rapid condensation of steam, that each square foot condenses from three to five times as much steam as will be condensed by the same area in an ordinary coil-radiator; in other words, only one-third to one-fifth the pipe is required to do

the same amount of heating. The saving in the heating-surface will usually pay for the fan and engine, so that the system becomes no more expensive than a direct-heating system.

But while in a direct system there is always danger from fire, freezing, and leakage, this is all obviated in the blower system. All the pipe is combined in a single heater, incased in a fire-proof jacket, and all valves are within easy reach, placing the entire control of the apparatus in the hands of a single individual. Furthermore, a much more rapid change in the temperature of the building is possible with the blower system than with any other system, either direct or indirect.

Most assuredly the system is worthy of investigation by any one requiring either heat or ventilation. It is now in use in some of the largest manufactories in the country, such as the Pacific Mills, Lawrence, Mass.; the New O. N. T. Clark Thread Mill at Kearney, N.J.; the Morgan Engineering Company, Alliance, O.; Niles Tool Works, Hamilton, O., etc.

Mr. Sturtevant has recently issued a handsome eighty-page illustrated treatise on ventilation and heating, which we are informed will be sent to any one requesting it.

BRICK FOR STREET-PAVING.

THERE are perhaps fifty cities in the United States using brick pavements. Some have had them over fifteen years. In Decatur, Ill., brick pavements have been in use for six years; in Bloomington they have been used for fifteen years; and in Charleston, W.Va., for a longer time. They are in use in Jacksonville, Peoria, Quincy, and Springfield, Ill., also in Kansas and Nebraska; and a number of cities in Ohio are using them with good results.

All brick pavements have not given satisfaction, as the contrary effect has been produced when common building-brick has been used. They begin to show the effects of wear in a very short time if soft brick is used, but good hard brick gives satisfaction. There is no paving-material equal to hard brick, excepting granite blocks, and it is doubtful if they would last as long were they as small as bricks. There are few cities in the United States where brick could not be laid for one-third the cost of granite blocks.

It may be urged that suitable clay for manufacturing paving-brick is scarce, but there is nothing in this country so plentiful. Of over twenty different samples of clay sent from various portions of Illinois and other States to the Decatur Tile Company, all excepting one have been made into paving-brick, although some kinds are much better for the purpose than others. This company has made about five million bricks per year during the past four years, seventy-five per cent being paving-brick. Over five miles of the streets of Decatur are paved with brick, and the City Council is planning to have more of them thus paved.

The clay used by the tile company mentioned is a common yellow joint clay, having a large percentage of silicate and iron. It is tempered or soaked for twenty-four hours before using, then carried by a belt to a stone-separator and crushers. Dropping from the crushers to an elevator, it is fed to the brick-machine. From this machine it runs in three streams upon a moving table, and is cut by wires, fastened in a frame, into bricks eight and a half inches in length. The die through which the clay is pressed on leaving the machine is 4 by 2½ inches. The bricks are then set upon drying-cars to be dried in hot-air tunnels, or set on slats in a building warmed by steam, or placed on a drying-floor heated from the burning kilns or small furnaces. When dry, they are carried in wheel-barrows and set "skintling," or at angles across each other, to allow the heat to pass between them in the down-draught kilns. Experience has proved that good paving-brick cannot be burned in open, up-draught kilns, if made from the clay described.

While some kinds of clay will stand fire long enough to burn as hard as rock in open kilns, yet even then the bricks would be much better in shape and quality if burned in closed kilns. The bricks are burned from six to seven days, the first three or four days very slowly, called "water smoking." It is necessary to watch very closely when finishing the burning, as there is great danger of running the bricks together and spoiling the whole mass.

The great drawback to using all kinds of clay is owing to the

gravel found in many clay banks. There are machines for separating the larger stones and crushing the smaller stones, which work very well excepting where there is limestone. The only remedy for that species of clay is washing, which is too expensive for common brick-making. A machine that will separate all gravel or other hard substances from the plastic clay, and leave it fine enough to be worked into terra-cotta, has been tested, and fulfils all the requirements. It is very simple, and will separate large quantities of clay with very little power. This machine will help manufacturers to use clays which at present are worthless, but which may become sources of wealth when passed through suitable machinery.

Some may smile at the idea of making bricks by machinery, but it is believed that brick-making by hand will soon become a thing of the past. The stiff-clay, machine-made brick will be used for paving purposes, bridges, docks, tunnels, and all works that require great strength; while dry-pressed brick will become the building-brick of the future.

Four specimen bricks made by the tile company mentioned, and picked up at random, were submitted to a test by the Chicago Forge and Belt Company about three years ago. The ultimate crushing resistances of the samples were 252,000, 228,000, 210,000 and 318,000 pounds respectively. The bricks measured $7\frac{1}{4}$ by $2\frac{1}{4}$ by 4 inches.

The construction of a brick pavement is a simple matter. The foundation being brought to the proper grade, there is spread over it six inches of gravel or sand, which is struck off with a board gauge fitted for the grade of the street. A course of brick is then laid on the flat surfaces, running lengthwise the street. It is not necessary that this course should be as hard as the upper course, being only a foundation for the brick that will receive the wear. Over this an inch of screened sand is spread, gauged, and properly smoothed off. The top course is laid with the bricks on their edges, lengthwise across the street. Care is taken to break joints in both courses. The whole is covered with an inch of screened sand, which is swept into the crevices. After this is done, a roller weighing five or six tons is passed over the pavement several times. If the street is properly rolled, it will be as smooth as wooden pavement, and almost as noiseless.

The street should be drained in some manner, as the lasting qualities of the brick and the even surface of the street depend to a great extent upon the drainage, as it is a well-known fact that water weakens brick very much. It would be a good plan to run a six-inch drain tile outside of the curbing, connected with a four-inch tile running through the curbing at the corner of each block. This will carry off all surface water; and, if the six-inch tile is about three feet below the surface, it will drain the sides of the street, so that water will not reach the foundation of the street.

The upper course should be very hard. The brick should be vitrified. It may be objected that if they are burnt to a glassy surface they will chip off or be crushed. That objection is not sustained. In Decatur are whole blocks paved with brick as smooth as glass and as hard as flint, and no brick of that description shows any signs of wear. The wear comes on the objects passing over the bricks, which are harder than steel, for a file will not scratch them: in fact, when broken open, they resemble flint.

Horses do not slip or fall on brick pavements as they do on granite blocks, owing to the small surface between the seams. Another advantage possessed by vitrified brick is that they will not soak water. If water and frost are kept out of brick, they are almost indestructible. Professor R. T. Brown says, "Clay well burned is as nearly a neutral substance as any in nature: its elements, being well united and in chemical equipoise, have no affinity for other substances that might disengage them from their combination. It is therefore chemically indestructible."

The Decatur Tile Company laid a block of brick four years ago, on a private contract, agreeing to make all repairs for five years free of charge. The street has not yet needed any repairs whatever, and from present appearances it will not be necessary to make any for the next twenty years. The first cost of such a pavement is low, the best pavement in Decatur costing only from \$1.25 to \$1.50 per square yard.

It was formerly thought that only certain kinds of clay could be

used for paving-brick, and the Decatur Tile Company is believed to have been the first to make it of common clay. Now there are a number of factories using the same kinds of machinery, and making the same quality of brick from such clay.

The following, from the *Clay Worker*, is of interest in this connection: "Brick-making has been dormant for nearly thirty centuries. From the time that clay-workers moulded and burned the bricks for the Royal Palace of Nebuchadnezzar, and stamped the royal signet on them, till the beginning of the present century, not a single step had been taken toward improvement in any of the processes involved in making and burning brick. Within the last fifty years, however, brick-making has been waked to new life, and now scarcely one of the old processes in its original form remains. Every thing, from the selection of the clay, to its preparation, moulding, drying, and burning, is stamped with innovation, may we not say with improvement? Machinery has been called in to aid this march of progress; and what had been the drudgery of hard labor, from the days when the Israelites toiled in the brick-yards of the Rameses, is now thrown on the broad shoulders of steam-power." It may be added that the greater improvements have been made in the last seven years, and still greater may be expected. By bringing the fuel and clay together with proper appliances, we may have good, clean streets in all our cities. And it would pay the farmers well if brick pavement should be extended into the country, as it would enable them to market their produce in winter, when otherwise the roads are impassable. It would also do away with road-taxes for a generation at least, for a road properly paved with hard brick ought to last fifty years, with very little repair. For a road paved, eighteen feet wide, with two courses of brick, at the prices of material and labor already given, the cost would be about ten thousand dollars per mile. Such roads might be considered expensive, but they would prove to be a good investment in the long-run.

J. G. SHEA.

A FIVE-MASTED SAILING-SHIP.

THE preference of ship-owners for large cargo-carrying vessels is becoming more and more pronounced, and the companies more particularly engaged in the part of the shipping trade in which sailing-ships are worked seem to vie with each other in securing "the largest ship afloat." Intimation is given in *Engineering* that a contract has been placed with a firm on the Clyde, who make the building of sailing-ships a specialty, for the construction of a five-masted steel sailing-ship to carry 6,000 tons dead weight. Not only will this be the first five-masted, but it will be the largest sailing-ship afloat. At present a vessel named "Liverpool" has this distinction. She has a gross tonnage of 3,330 tons, her length being 333 feet, breadth 47.9 feet, and depth 28 feet moulded. Brokers, too, like the big ship, and the reason is so evident that it is not necessary to refer to it; but underwriters do not seem so much enamored with it. Quite recently one of the largest vessels—shorter by 10 feet, but broader by $1\frac{1}{4}$ feet, than the "Liverpool"—was chartered to take coal; but, when all the debatable points of a charter were settled, the underwriters had to be reckoned on, and they desired such a premium as made it quite impossible to proceed further in the matter,—something like £10 to £15 per £100. They contended that the greater the quantity of coal carried, the greater the danger of fire. This vessel, however, has made several voyages, and no difficulty is now being experienced with the insurance firms. They will be educated to a higher standard, although at present a little conservative. There is another difficulty, however, which cannot be so readily overcome. Such large vessels can only be employed profitably in certain trades, and great inconvenience must arise unless suitable graving dock accommodation can be afforded at the large trading ports. No difficulty will be experienced at home; but in Calcutta, for instance, one of the big ships now afloat presented itself recently for admittance to the dock, and it was found that her beam was too great; and yet boats with more beam will be built. The result was that she had to load, and hope for better accommodation at her next port. San Francisco and New York have large docks, but the importance of Calcutta port for ships cannot be ignored.

ELECTRIC-LIGHTING STATIONS IN EUROPE, AND
THEIR LESSONS.

PROFESSOR GEORGE FORBES read on Feb. 28, before the English Institute of Electrical Engineers, a paper with the above title, which gave the results of his inspection of the electric-lighting stations at Berlin, Rome, and Milan. He first described the Berlin central stations. There are three of these, using a direct-current, low-pressure system, and connecting with the same network of mains. Of the three stations, that on Markgrafen Strasse is the most important. It contains six engines of 160 horse-power each, each driving an old-fashioned Edison dynamo; with four other engines of 400 horse-power each, driving a new type of dynamo direct, at 80 revolutions per minute. These last dynamos are worthy of notice: they are multipolar Gramme machines, with radial poles inside the Gramme ring armature. There are ten poles; the armature is 3 metres in diameter; the commutator is $1\frac{1}{2}$ metres in diameter. There are ten brushes, and the different circuits are connected in parallel. The advantage of this type of dynamo, provided it is an advantage, is in the slow speed at which it can be run. The capacity of the station is about 2,600 horse-power, which gives about 26,000 lamps of 16 candle-power. In the system of distribution employed, the two-wire plan is adopted, although in the later additions that are being made the three-wire system is to be used. The network of mains is supplied at intervals by "feeders," which are used to equalize the pressure at all points and times, there being no less than forty-two pairs of feeders. The cables consist of stranded wires covered with jute prepared with a bituminous compound, enclosed in lead, then covered with tape and a preservative compound, and finally armor-plated with two crossed spirals of iron ribbon. The cost of the underground cables for the whole system has so far amounted to about £90,000; the greatest variation of pressure allowed in the mains is $\frac{1}{3}$ per cent; the loss in the feeders at maximum load is 15 volts. The performance of the cables for three years was excellent; but Professor Forbes states that lately water has penetrated the lead, has percolated to the copper, which is then destroyed. "Whatever the cause may be, the fact seems to be established that such a cable will not stand underground electric-light work for more than about three years. These cables generally run under the footways without any casing."

The second of the three Berlin stations is in the Mauer Straus. Besides supplying incandescent, it supplies arc lamps. The low-tension outfit consists of four Edison machines and six multipolar machines, supplying altogether 11,000 lamps.

The third station is small, and contains four Edison machines driven by the same number of 75-horse-power Armstrong & Sims engines. Fifty-two men are employed at the three stations in eight-hour shifts. The company which does the central-station work paid last year a dividend of $\frac{7}{8}$ per cent.

In the central station at Milan, both arc and incandescent lamps are supplied. Of the former, there are 350 of the Thomson-Houston system; of the latter, there are 16,000, fed by both the direct system and the alternating system. For the continuous system, Edison meters are used, and give great satisfaction. The distribution is on the two-wire system, as in Berlin, the current being supplied from ten Edison dynamos. The high-tension alternating system is the Ziperowski-Deri system, there being two machines, each of 2,000 volts and 40 amperes.

The capital of the company is \$600,000, of which \$120,000 has been spent in conductors. Wages is one-fifth of the total working expenses; coal, one-half; lamp renewals, 7 per cent. The company has paid dividends for several years. The last was 4 per cent, and it is increasing. There is a large reserve fund.

The central station in Rome was started by the gas company there. The alternating system is used for both arc and incandescent lighting. At present 9,000 incandescent and 200 arc lamps are supplied. The number of alternations is 83 a second, or 41 complete periods a second. The greatest distance to which current is at present supplied is about three miles. The voltage in the primary circuit is 2,200; in the secondary, 110 volts. The converter is an anchor ring built up of iron disks wound over with the primary and secondary circuits. The dynamos are of two sizes.

The smaller are of a size to supply 1,000 lamps. There are 20 poles, and the machine makes 250 revolutions a minute. The larger size have 40 magnet-poles, and make 125 revolutions. "When the machine is illuminated by an arc light, to which it supplies current, a curious optical effect is produced. The arc being periodically made and broken, the revolving magnet-poles are seen fixed in position, and the amount of lag with different loads can be seen distinctly. The efficiency of these machines is said to be 90 per cent, including the exciting current. There are 50 converters now at work, each of 10 horse-power. The efficiency of these converters is 95 per cent at full load; of the 5-horse-power converters, 92 per cent; of the $2\frac{1}{2}$ -horse-power, 88 per cent. After describing these stations, Professor Forbes proceeded to draw from his observations some lessons which will be of use to English engineers in the remarkable extension of electric lighting which is going on in that country, especially in London. He called attention to the fact that the continental low-pressure systems used a two-wire instead of a three-wire distribution: this he condemned as causing a great and needless expenditure for copper. Again the importance of feeding-wires was emphasized. Professor Forbes contrasted the variation in the potential of the lamps that would occur at a point 960 yards distant from the central station, using conductors which carried 1,000 amperes per square inch. For a two-wire system, the variation would be 48 volts in 100; a three-wire system, 12 volts; a three-wire system with feed-wires, the total amount of copper being the same as in the last case, 1 volt. The first two would evidently not be practical systems; the last would be satisfactory. In this connection, Professor Forbes pointed out that feeding-wires were also necessary in the high-potential alternating system, in order that the lamps should maintain a uniform brilliancy, and referred to the unsatisfactory showing of the Grosvenor Gallery Station, where the alternating system is used, and where no feeders are employed. Professor Forbes seems inclined to take a somewhat pessimistic view of the future of underground cables. Those in Berlin, he states, only last three years, and, "on looking through the testimonials of makers, he does not find that cables, when placed under ground, have ever worked electric-light circuits satisfactorily beyond the three years fixed by the Berlin people as being destructive." On this side of the water the Edison Company has done much better than this with their insulated copper rods carried in iron pipes. As the result of his observations on this point, however, Professor Forbes says, "At the present moment it seems to me that the only types of underground cables proved suitable for permanent work are either bare copper supported on insulators, or else vulcanized India-rubber, or perhaps okonite. Especial care must be taken to avoid an insulator which is injured by the gases which permeate the soil of a town, or which has the property, like pitch, of becoming viscous, and so letting the copper become decentralized."

It seems the experience of most electrical companies, that it pays better to use a meter on the consumer's premises, and charge for the actual amount of current consumed, than to supply light by contract. Of the different types of meters, the Edison and Avon meters can be used for continuous currents; the Schallenberger meter, for alternating currents. Professor Forbes thinks that the efficiency of converters for the alternating system is overrated. While the maximum efficiency might be from 90 to 95 per cent, yet the efficiency is much less on small loads, and he would be surprised if the average efficiency for all except two types would be over 70 per cent.

A great difference between the practice in this country and abroad is in the speed of the dynamos. Here very high speeds are used; abroad low speeds are aimed at. The advantage of the former is in the greater output and efficiency from the same-sized machine; the disadvantage is in the greater liability to accident; but, as these are extremely rare, the possibility of failure can hardly be regarded as balancing the advantages.

To an American reading the paper, there is the satisfaction that our own central stations are far in advance of those described; while nearly, if not quite, all of the recommendations are in the direction of the established practice in this country.

NOTES AND NEWS.

THE third field-meeting of the Indiana Academy of Sciences will be held at Greensburg, Ind., May 8, 9, and 10. The first meeting will be held at 7:30 P.M., Wednesday, May 8, at which time, in addition to miscellaneous business, a popular address will be delivered by Dr. J. P. D. John, the retiring president, upon "Our Celestial Visitors." As important business is to be transacted at this meeting, it is very desirable that as many members report as possible. It is particularly desired that all the members of the executive committee and of the committee on meeting of the American Association for the Advancement of Science at Indianapolis be present. The next day, Thursday, May 9, will be spent in the field along Cobb's Fork of Sand Creek. The citizens of Greensburg will furnish carriages. The creek will be followed for about four miles. Here are to be found the rarest plants of the county; the junction of the Lower and Upper Silurian, rich in fossils; and as much zoological material as can be found in the region. It will be a very profitable trip for all departments of field-work. Returning to Greensburg in the evening, another public meeting will be held at 7:30 P.M. This meeting will be of a somewhat varied character, consisting of brief reports by different members of the academy upon results of the field-work of the day. The meeting will be of special interest to the citizens of Greensburg, as they will hear discussed, in a popular way, the most interesting scientific features of their own vicinity. Friday morning another excursion will be made, as interesting as that of the day before. The details have not been fully determined, but every thing will be arranged for. This excursion of Friday will close the work of the academy.

— The abandonment of silk-culture in California, according to *Bradstreets*, is foreshadowed by the action of the governor of that State in vetoing an appropriation of ten thousand dollars made by the legislature to carry on experiments in that direction. The reason given is that California cannot compete with China or Japan in that industry.

— The solid matter present in mineral oils has recently been examined, says *London Industries*, by J. A. Le Bel, who has satisfactorily established the fact that asphalt obtained from petroleum and bitumen contains, in addition to an oxidized organic coloring-matter, a large percentage of inorganic constituents. The ash from a specimen of asphalt obtained from mineral oil procured from Egypt contained 11 per cent of lime and sulphur, while the asphalt derived from the Crimean oils yielded 6 per cent of ash. Purified asphalt from Lobsann, in Alsatia, gave 5.4 per cent of ash, consisting of lime, oxide of iron, silica, sulphuric acid, and a trace of manganese. The presence of silica in the ash, the author considers, supports the hypothesis of Mendelejeff, that the mineral oils are formed by the action of steam on the heated rocks of the interior of the earth. In the asphalt from Lobsann, Le Bel has also obtained 4.9 per cent of sulphur in combination with silicon.

— The manufacture of artificial coffee from burnt flour or meal is reported to be carried on by certain firms in Cologne. *London Industries* explains that the artificial beans are made in specially devised machines, and resemble closely in appearance the natural ones. They have been examined by O. Reitmaier, who has shown that they consist of 34.6 per cent of extract soluble in water, mixed with 56.25 per cent of insoluble organic constituents. The amount of ash on ignition is small, amounting to 1.10 per cent. They can be readily distinguished from the natural beans by their property of sinking when immersed in ether, as genuine coffee-beans float on that liquid. Strong oxidizing agents do not decolorize the artificial product so rapidly as natural coffee.

— A correspondent of *The American Field*, after reading Greener's "Modern Shot Guns," noting that the author states that he has never known of snow causing the bursting of a gun when gotten in the barrel, vouches for its having done so in one instance, and believes it will in most cases, with ordinary charges, if the snow completely plugs the end of the barrel, though it may not cause as bad a burst as a more solid substance, as mud. Some years ago, while shooting with an English-made muzzle-loader, this correspondent got a small quantity of snow in one barrel, and carelessly discharged the gun before re-

moving it, with the result that about an inch of the metal at the end of the barrel was torn away at top and side (being twisted and bent over toward the outside of the barrel). The recoil was not very great. The gun was a heavy one, with good-quality barrels, and the charge only ordinary or rather below the average. Doubtless the result would have been worse with more than a small quantity of snow in the barrel. The barrels were cut off below the break, and have been used many times since.

— Dr. A. T. Hudson of Stockton, Cal., has made a statement which, in the opinion of *The American Field*, will be contradicted by scores of people. Dr. Hudson asserts that whiskey is no antidote for rattlesnake-poison, on experiments made by Dr. S. Weir Mitchell. He says, "Dr. Mitchell mixed the virus of the rattlesnake with alcohol and with other reputed antidotes, and found, on injecting the solution into animals, that its power was not altered. He found also that the effect of the virus was subject to very well defined limits, and that a quantity which would kill an animal of a certain size was much less powerful or inert upon larger animals. If a large snake should bite a goat of about fifty pounds weight, and afterward two children of corresponding weight, he might kill the goat, while the children would survive, because not enough virus was left after the goat was bitten seriously to harm the children; then, if whiskey were given to the children, their recovery would be attributed to it, while it really had nothing to do with the matter. It is rare that an adult person dies from the bite of a rattlesnake. Whiskey may, however, be regarded as physiologically antidotal, in so far as it will sustain the flagging powers while the poison is being eliminated by the excretory organs."

— For a long time the quarters occupied by the live animals at the Smithsonian Institution, Washington, D.C., have been infested by rats; and every means known for their destruction or extermination have been used, but all to no purpose, as the rats are steadily increasing in number. They seem to know what rat-traps are for, and keep out of them, no matter how tempting the bait. But last week, according to *The American Field*, Capt. Weedin, who has charge of the animals, made a valuable discovery, by means of which he expects to clear the place of these destructive vermin. In a storeroom drawer a quantity of sunflower-seeds, used as food for certain of the birds, was placed, and it was noticed that the rats eagerly gnawed their way through the drawer to get at the seeds, which they evidently relished. Acting on this supposition, Capt. Weedin baited his rat-traps with the seeds, and there was no more astonished man in Washington than he was when he discovered, the next morning, that every trap so baited held from ten to fifteen rats each. The rats were turned into the cages containing the weasels and minks, which did the killing in less time than it takes to tell it. The minks would kill the rats instantaneously.

— The Ventura Society of Natural History was organized in San Buena Ventura, Cal., in June, 1884. It numbers about fifty members, and holds its meetings once a month. The society has made collections in minerals, fossils, conchology, botany, etc. Rev. Stephen Bowers, Ph.D., has been president of the society from the time of its organization. Congressman Vandever and other prominent men are active members; and while but a small proportion of its members have time for original investigation, yet it is said to be doing good work in some departments of science. Dr. Bowers has been instrumental in securing one of Mr. Alvan Clarke's best six-inch lens telescopes, which will be erected upon an eminence north of the city overlooking the Santa Clara valley of the south, the Pacific Ocean, and the coast range of mountains.

— A very interesting report to the United States Hydrographic Office from Commander Allen D. Brown, U.S.N., commanding the U.S.S. "Kearsarge," shows an abnormal state of the weather and ocean-currents about Barbadoes. From March 16 to 25 the trades disappeared entirely, being replaced by calms and light variable winds, chiefly from the westward, with frequent rain-squalls, — most unusual weather. March 19 and 20, strong south-easterly currents were observed (to the southward and eastward of the island), thirty and twenty knots a day respectively; March 29, between Barbadoes and Martinique, a current setting due north, ten

knots in fourteen hours; and in the passage between Martinique and Santa Lucia, four knots in one hour, and eight in four hours. Both the last two observations were by bearings.

— The International Congress of Anthropology and Archæology will hold its tenth meeting at Paris. When the congress adjourned at Lisbon, in 1880, no arrangements were made for future sessions. Notwithstanding numerous endeavors to bring about a new meeting, the congress did not assemble for eight years. In July, 1888, a number of French anthropologists, who considered the great International Exhibition a good opportunity of re-organizing the congress, proposed to the permanent committee of the congress to arrange for a meeting in the present year. A committee was appointed, the president of which is the eminent anthropologist, A. de Quatrefages, and invitations have been sent out. The congress will hold its tenth meeting at Paris from Aug. 19 to Aug. 26. The following questions are proposed as subjects of discussion by the committee: (1) the erosion and filling of valleys and caverns in reference to the antiquity of man; (2) the periodicity of glacial phenomena; (3) art and industry of the caves and of the alluvium; value of paleontological and archæological classifications applied to the quaternary epoch; (4) chronological relations between the stone, bronze, and iron ages; (5) relations between the civilization of Hallstadt and other Danubian stations, and those of Mycenæ, Tiryns, Issalik, and of the Caucasus; (6) critical examination of quaternary crania and bones found during the past fifteen years; ethnical elements of the various stone, bronze, and iron ages of central and western Europe; (7) ethnographical survivals, which may throw light upon the early inhabitants of central and western Europe; (8) how far do archæological and ethnographical analogies justify the hypothesis of affinities or prehistoric migrations?

— At the meeting of the New York Academy of Sciences, April 22, Mr. John C. Henderson read a paper on the proposed Tehuantepec Ship Railway. Mr. Henderson's paper was followed by an interesting discussion, which is reported in *The Railroad Gazette*. Gen. Andrews said that canals had played a conspicuous part in past history, and even now they have not fallen into disuse, and in countries of a lower grade of civilization, such as China, they are the chief arteries of commerce. It is estimated that the traffic on the canals of China equals, or perhaps exceeds, the combined commerce of all the rest of the world. But progressive nations are abandoning canals, and substituting railroads. Experience proves that railroads can work cheaper than canals. If New York State should fill up her Erie Canal, and build a four-track railroad, she could haul freight over it cheaper than the canal-boats can carry it. Estimates which he regards as incontrovertible show that a ship can be hauled by a locomotive over a ship-railroad, or, as he prefers to designate it, a ship-tramway, with the expenditure of only one-half the amount of coal which the same ship must burn to propel herself through the water of a canal. The most frequent objection urged against the practicability of the scheme is that it would rack the ship; but Gen. Andrews explained that the weight is so distributed among the numerous supports that no one need sustain a greater weight than a man presses upon his foot in walking. The gradients of the route will be very slight, not exceeding two inches in four hundred feet, the entire length of a vessel. He had made observations, during a voyage aboard the steamer "Britannic," to measure the amount of strain to which she was exposed in a sea of no very great roughness, and found by stretching cords that the steamer was bent sixteen inches by the waves, but without the slightest injury: hence he infers that the stress on a vessel in crossing the isthmus would be inappreciable and harmless. A powerful argument, he holds, in favor of the Tehuantepec route, is that it is the nearest to this country, and is in the region of winds, so that sailing-vessels could use it; whereas Panama is almost a dead calm, and even Nicaragua is not to be depended on by sailing-vessels. The result of opening either of the southern routes, therefore, would prove to be, as the Suez Canal has already proven, that the route would be monopolized by British steamers, and that the American flag would not be seen. President Newberry said that the proposed scheme appears to be practicable, but that it is so novel as to seem to require the test of experience before we can

be certain that all practical difficulties will be successfully met. The smaller ship-railroad from the Bay of Fundy to the Gut of Canso is being rapidly constructed, and will probably be in operation by about September, 1890. The results will be watched with interest, and, if successful, the larger work at Tehuantepec will undoubtedly soon follow.

— It is stated, that, notwithstanding the threatened opposition of the English Government, the Channel Tunnel Company will proceed with the bill which it proposes to bring before Parliament, and take a division upon next session. It is said that since last year the promoters have received great encouragement to proceed, particularly from a large number of persons connected with the manufacturing and commercial centres of England and Scotland. They have also in many cases been promised the support of several members of Parliament. The following from *Iron* (London) gives the present status of the tunnel: "The machinery which was used for boring the tunnel is still in the heading, and is periodically set in motion to keep it in order; but no attempt is made to advance the heading, the length of which measures about 2,100 yards. It is now two years since the works were stopped; and the tunnel is said to be so far impervious to water, that, on an average, not more than 400 gallons has found its way into the entire heading in the course of twenty-four hours. The boring operations for coal near the mouth of the tunnel still continue, and a depth of about 1,000 feet has now been attained. The character of the strata is such as to encourage the continuation of the operations in the hope of ultimately finding coal. While the prosecution of the borings for coal ought to be encouraged in every way, the same cannot be recommended for the tunnel-works. In the present state of public opinion, the money spent that way will only be wasted."

— An alarming illustration of the facility with which steel corrodes under certain conditions, the *Engineer* says, has just been observed at Portsmouth, England. H. M. S. "Nile" was launched at Pembroke on the 27th of March last, since which time, as there is no dock accommodation at the Welsh yard, she had been afloat in her launching trim without there being any opportunity afforded of examining and protecting the under-water parts of the hull. When she was placed in No. 13 dock at Portsmouth for the purpose of removing the launching gear, and changing her temporary propellers, it was discovered that the red lead with which her bottom was coated had extensively peeled off, and that serious corrosion of the plating all along the water-line on both sides had taken place. The starboard side amidships was very much pitted, though, as a rule, the pitting and scoring were tolerably uniform. The rivet-heads were greatly corroded, and in many instances they appeared to be completely eaten away. The same is said to be the case with some of our new steel war-vessels, the steel being extensively pitted, especially along the water-line.

— Although West Indian hurricanes may be encountered during any month of the year, yet there is such a marked increase in their number and violence during July, August, September, and October, that these four months constitute what is called the hurricane season. In regard to the hurricane regions, the United States Hydrographic Office says that they include the tropics north of the 10th parallel, the Caribbean Sea, Gulf of Mexico, and a broad belt curving north-westward from about St. Thomas, and following the Gulf Stream towards the Grand Banks of Newfoundland. The earliest indications are unusually high barometer, with cool, dry, fresh winds, and very transparent atmosphere; a long, low ocean-swell from the direction of the distant storm; light, feathery plumes of cirrus clouds, radiating from a point on the horizon where a whitish arc indicates the bearing of the centre. Unmistakable signs are the following: As the cirrus-veil spreads overhead, with halos about the sun and moon, the barometer begins to fall, slowly but steadily, and the ocean-swell increases; the air becomes heavy, hot, and moist; dark red and violet tints are seen at dawn and twilight; the heavy cloud-bank of the hurricane soon appears on the horizon, like a distant mountain-range; the barometer falls more rapidly, and the wind freshens, with occasional squalls of fine, misty rain. As regards the general size and velocity of progression, the storm area is smaller in the tropics than farther north, the

cloud-ring averaging about five hundred miles in diameter; and the region of stormy winds, three hundred miles, or even less. In low latitudes the entire storm moves westward and north-westward, about seventeen miles an hour; in middle latitudes, north-westward and northward, moving more slowly as it recurs; and finally north-eastward, with a velocity of translation of twenty or even thirty miles an hour, its area increasing rapidly as it follows the Gulf Stream toward the Grand Banks, and sweeps across the Atlantic toward northern Europe.

— The weather forecasts for May of the Hydrographic Office are, that fair weather will prevail generally over the North Atlantic with occasional northerly gales along the American coast, and moderate north-westerly gales along the transatlantic steamship routes, north of the 40th parallel. Northerners in the Gulf of Mexico will occur less frequently, and be of less duration, but are liable to be of great violence. There will be a notable increase of fog off the Grand Banks, due to the northward movement of the Gulf Stream and the southward extension of ice brought down by the Labrador current. Icebergs and field-ice may be encountered almost as far south as the 40th parallel, between the 41st and 58th meridians.

— A large assemblage of men and women who are interested in the discussion and study of psychological matters gave Professor Elliott Coues a hearty reception at Cartier Hall, 80 Fifth Avenue, New York, Wednesday evening, April 24, when he lectured on modern miracles.

— The semi-annual meeting of the American Antiquarian Society was held at Boston, April 24. President Salisbury presided. The secretary reported the acknowledgment by Gladstone of his election as a member of the society. The report of the treasurer made the following showing: cash investments, \$107,141; cash on hand, \$7,609; amount of the thirteen funds, \$105,937. On motion of Senator Hoar, the society voted to ask the Rev. Dr. Hamlin to prepare a history of the Roberts College, Constantinople, together with the attitude of the Turkish Government toward it.

— The executive committee of the International Exhibition of Geographical, Commercial, and Industrial Botany, to be held at Antwerp in 1890, we learn from *Nature*, has decided to celebrate on this occasion the three hundredth anniversary of the invention of the microscope. It proposes to organize what it calls a retrospective exhibition of the microscope, and an exhibition of instruments produced by living makers. Conferences relating to all important questions connected with the microscope will also be held. The exhibition ought to be remarkably interesting, and will no doubt be a great success.

— According to a recent statistical return, 12,486,407 hectolitres (hectolitre = 22 imperial gallons) of beer were produced last year in Austria, Bosnia, and Herzegovina,— a falling-off of 190,019 hectolitres as compared with 1887. The exports, however, increased by 9,087 hectolitres, having amounted to a total of 250,963 hectolitres.

— Professor Liebreich, at a meeting of the Berlin Physical Society, March 22, exhibited a series of experiments intended to explain the occurrence of the inert layer in chemical re-actions. Two years ago, we learn from *Nature*, he had demonstrated to the society the chief phenomena of its occurrence, as seen when a solution of sodium carbonate is mixed with chloral hydrate. When this is done, the larger part of the mixed fluids very soon becomes milky, owing to the formation of innumerable small drops of chloroform, while at the same time a thin layer on the surface of the fluid remains clear. This clear portion is the inert layer, and is bounded above by the general meniscus of the mixture, and below by a curved surface, whose convexity is turned upwards towards this meniscus. The speaker had, by means of a series of experiments, disposed of the view which had been put forward, that the inert layer is only a portion of the mixed fluids, from which the chloroform had evaporated. Of these experiments it may suffice to mention only one, in which the fluid was poured into a flat, open basin until it projected with a convex surface above the edges of the basin. Notwithstanding the larger fluid-surface thus exposed, no inert layer was to be seen. Similarly he had been able to show,

by observations under the microscope, that the phenomenon cannot be explained by any vortex movements in the fluid. Further, the assumption that it is due to a solution of alkali from the glass, which then prevents the precipitation of the chloroform, had been excluded by using a vessel made of quartz crystal. Professor Liebreich inclined to the view, on the basis of his past experiments (which, however, must be further followed and extended), that the suppression or slowing of the chemical re-action at the surface of the fluid, which gives rise to the inert layer, is determined by the greater solidity and resistance of this part of the liquid.

— At the Massachusetts Agricultural College Experiment Station, according to *Garden and Forest*, pollen was taken from a carnation-flower of a magenta color, and, after being kept in a dry place for five days, was applied to the stigmatic surfaces of a yellow flower. From twenty-seven seeds obtained by this crossing, nineteen plants were grown, all but one of which produced double flowers. Five of them bore yellow flowers of various lighter and deeper shades, eight bore magenta flowers, four bore scarlet flowers, and two white-striped flowers. In another trial the pollen used was taken from a flower of the same variety, — in this case a yellow-striped one, — and the seedlings all showed yellow-striped flowers, although they varied somewhat in shade. This seems to indicate that for the production of varieties distinct in color, cross-fertilization is a necessity.

— *Garden and Forest* quotes this simple method of testing the quality of a pear: write a name with pen and ink upon the dry skin of the fruit. If the ink is quickly absorbed, leaving clear, sharp lines, the quality of the fruit is good; if the skin does not absorb the ink quickly, and the lines are blotted, the quality is inferior.

— Four articles have been prepared at Harvard College Observatory in successive years, with the object of exhibiting, so far as conveniently practicable, the recent progress of observations of variable stars. These articles were published in the "Proceedings of the American Academy of Arts and Sciences." An index to observations of variable stars, just published, is intended to provide similar information for the entire period from the beginning of 1840 to the end of 1887. It makes no pretension to absolute completeness, which would not at present be attainable; but it may still prove serviceable as a further step towards the systematic arrangement which is so much to be desired in the existing mass of information respecting variable stars, and in the absence of which the profitable study of their changes is extremely difficult. The observations are in general unpublished, and have been reported to this observatory by the astronomers who made them. It may be hoped that this record of their existence will in some cases insure their preservation, and make them available to future inquirers. It will also show to what extent particular variable stars have been observed at particular times, and will thus serve to guide observers in the selection of stars for future observation. Three large series of unpublished observations by Argelander, Heis, and Schmidt, important both from their early date and from the reputation of the observers, are mentioned.

— Mr. C. Carus-Wilson writes, in a letter to *Nature*, that he has devised a simple and effective dry method by which the denser minerals — zircon, rutile, tourmaline, etc. — may be separated from sand. A piece of cardboard about two feet long is bent in the form of a shoot or trough (it must not be allowed to break), and held in this form by elastic bands at either end. This must then be held, or fixed, at an angle sufficiently inclined to allow the sand to travel slowly down the shoot on being gently tapped. A small quantity of the sand to be treated is now placed at the head of the trough, which is then tapped with the finger. When the trough is tapped, the sand travels slowly down; and, in doing so, the denser grains lag behind, forming a dark mass in the rear of the stream. This dark mass increases as the sand flows on, and must be collected and placed in a receptacle just the moment before the last tap would cause it to fall off the trough. When a sufficient quantity of this denser sand has been thus collected, it should be placed in the lid of a cardboard box (about twelve inches by six), and gently shaken to and fro at a slightly inclined angle, the mass being

at the same time gently blown upon with the breath. The finer quartz-grains will thus be blown away, and hardly any but the denser grains will remain.

— During last year the archaeological researches that have been carried out in Norway were extended as far north as $70^{\circ} 15'$ north latitude, according to *Nature*. The results appear to show that the islands and the coast were well populated in prehistoric times, but that the cultivation of the soil did not begin until a late date. Numerous burial-places were found; and among the weapons and implements discovered were schist arrow-heads, knives of three kinds, and chisels. No stone axes like those found in the south were discovered. From the fact that no bronze objects have ever been found in the north of Norway, it is concluded that the inhabitants of the stone age, on coming in contact with those of the early iron age, adopted the use of iron, and never learned the use of bronze. It is worthy of note that all the implements from the stone age are of schist, none being of flint, as in the south.

— At a meeting of the Berlin Physical Society, March 22, Dr. Assmann gave, according to *Nature*, an account of the results he had obtained by a microscopic examination of the structure of rime, hoar-frost, and snow. In opposition to the view most usually held, that the solid condensations of aqueous vapor from the air are crystalline, he had observed some years ago, during a sojourn in winter on the Brocken, that hoar-frost consists of amorphous frozen drops, which, by their juxtaposition in rows, build up the long needles of which it is composed. He observed the same structure in some rime which he had collected from very various objects in December last, during a cold which was not at all intense; in this case, also, the spicules of ice were composed of amorphous drops of ice frozen together in lines. In one case the little masses of ice which composed the rime were frozen together into a leaf-like structure. At the same time some small, scattered, and glittering ice-formations which had been formed in large numbers on the ground were crystalline in structure, consisting of thicker or thinner six-sided tablets or somewhat elongated prisms. On other occasions he found that the rime was itself composed of unequally developed crystalline structures, which branched at angles of sixty degrees, and thus gave rise to a dendritic formation; at the same time the hoar-frost was also composed of crystalline structures. He had also succeeded in forming ice-flowers artificially on a pane of glass, and had satisfied himself by a microscopic examination of the same that they are always crystalline in structure. The structure of snow was investigated on the snow-garlands which had been described at a meeting of the Meteorological Society, and consisted of amorphous granules, such as compose the upper surface of a glacier. Dr. Assmann attributes the formation of rime and of hoar-frost to the existence of over-cooled drops of water, which suddenly solidify when driven by the wind against the solid substructure on which they are found. On the other hand, solid transparent ice is formed when water at 0° , or some temperature above zero, comes in contact with any solid object whose temperature is very low.

— At a meeting of the Berlin Meteorological Society, April 2, Professor Börnstein spoke on the ebb and flow of the tide. After explaining the nature of the moon's action on the fluid part of the earth's surface, and showing that the flood is essentially due to a diminution of gravity and the ebb to its increase, says *Nature*, he passed on to the consideration of the moon's attraction as it affects the atmosphere. Many experiments have been made with a view to proving the influence of the moon on the atmosphere; and at various places observers have succeeded in establishing a daily variation in the pressure of the air dependent upon the moon, and showing two maxima and two minima. These places are Singapore, St. Helena, Melbourne, and Batavia. The amplitude of the variation amounted to from 0.079 to 0.2 of a millimetre. But opposed to these are the observations of Laplace on the variations of the barometer in Paris, as also of Kreil in Prague, and, further, Bessel's observations on atmospheric refraction. All these last-named observers found that the action of the moon on the earth's atmospheric envelope was either *nil* or else the reverse of that described above. Professor Börnstein then discussed the question

whether any ebb and flow of the atmosphere could possibly be detected with the means now at our disposal, and showed that the mercurial barometer can never be able to give indications of any such action, since it is itself affected by the alterations of gravity which are due to the varying position of the moon. He explained the phenomena observed at the four stations mentioned above as due to the fact that they are situated either on the sea-coast or on islands, at places on the earth's surface at which the ebb and flow of the sea is very considerable. The ebb and flow of the sea acts secondarily on atmospheric pressure, especially by means of the alteration of surface, and gives rise to corresponding increases and diminutions in that pressure. Paris, Prague, and Königsberg are, on the other hand, inland stations, at which the barometer cannot be affected by any variations on the level of the sea's surface.

— The public funeral of M. Chevreul, which took place in Paris, Saturday, April 13, says *Nature*, was one of great splendor. This was due in part, no doubt, to the interest excited by M. Chevreul's extraordinary age; but it must also be taken as a striking indication of the respect felt in France for men who achieve eminence in science. In front of the house in which M. Chevreul died, beside the Jardin des Plantes, a tent was fitted up as a chapel; and here the body was placed in state. The procession to the Cathedral of Notre Dame was headed by a detachment of police, who were followed by a platoon of cuirassiers, the 103d Infantry Regiment, with flags and a band of ushers, carrying wreaths presented by the stearine-makers of France, the stearine-makers of Lyons, the Friendly Society of Anjou living in Paris, and a large number of other public and private bodies. Last of all came a wreath sent by the Gobelin Works, surrounded by a woollen fringe dyed by M. Chevreul himself. The pall-bearers were MM. Fallières, minister of public instruction; Louis Passy, president of the Society of Agriculture; Chaumeton, president of the Students' Association; Des Cloizeaux of the Academy of Sciences; Quatrefages of the Academy of Sciences; Chautemps, president of the Municipal Council of Paris; and Roy, manager of the Society of Arts and Manufactures. Next came the members of M. Chevreul's family, grandchildren and great-grandchildren; and they were followed by the representatives of the president of the republic, by several of the ministers, the presidents of the Senate and the Chamber, and representatives of all the great educational and scientific bodies and administrative departments. At Notre Dame there was an impressive religious service. The interior of the church was hung with black; and over the porch, which was also hung with black, was a scroll bearing the dates "1786-1889." In the centre of the choir was a catafalque resting on silver columns, and surmounted by a canopy with bands of ermine. After the religious ceremony, the body was removed to L'Hay, and interred in the family vault. In compliance with M. Chevreul's last wishes, no speech was made over his grave.

— The Massachusetts Agricultural College, says *Agricultural Science*, is in a most prosperous condition. At no time, with one exception, has there been a larger attendance of students; the total for the year 1888-89 being 149, the freshman class being 48. The library contains 8,285 volumes, and during the year the students drew out on an average 14 books each. Of the graduates of the college, 46 are farmers, 6 fruit-growers and market-gardeners, 8 florists and landscape-gardeners, 4 planters, 9 poultry and stock raisers, 7 veterinarians, 2 editors of agricultural papers, 4 fertilizer manufacturers, 9 chemists to fertilizer companies, and 28 engaged in agricultural colleges or experiment stations. There are 150 other graduates engaged in various occupations. The college farm is being much improved, and has 46 head of cattle, consisting of Jerseys, Guernseys, Short-horns, Holstein-Friesians, and Ayrshires, 31 pigs, and 23 Southdown sheep. In 1888, 212 tons of hay were cut from a little over 80 acres of land.

— The officers of the Boston Society of Natural History for 1889-90 are, president, F. W. Putnam; vice-presidents, John Cummings, G. L. Goodale; curator, Alpheus Hyatt; honorary secretary, J. C. White; secretary, J. Walter Fewkes; treasurer, Charles W. Scudder; librarian, J. Walter Fewkes.

SCIENCE:

A WEEKLY NEWSPAPER OF ALL THE ARTS AND SCIENCES.

PUBLISHED BY
N. D. C. HODGES,

47 LAFAYETTE PLACE, NEW YORK.

SUBSCRIPTIONS.—United States and Canada.....\$3.50 a year.
Great Britain and Europe..... 4.50 a year.Science Club-rates for the United States and Canada (in one remittance):
1 subscription 1 year..... 8 3.50
2 " 1 year..... 6.00
3 " 1 year..... 8.00
4 " 1 year..... 10.00

Communications will be welcomed from any quarter. Rejected manuscripts will be returned to the authors only when the requisite amount of postage accompanies the manuscript. Whatever is intended for insertion must be authenticated by the name and address of the writer; not necessarily for publication, but as a guaranty of good faith. We do not hold ourselves responsible for any view or opinions expressed in the communications of our correspondents.

VOL. XIII.

NEW YORK, MAY 3, 1889.

No. 326.

CONTENTS:

STORAGE-BATTERIES FOR STREET-CARS.....	331	BOOK-REVIEWS.	
IVORY VARNISH.....	332	Psychology as a Natural Science...	344
THE JULL SNOW-EXCAVATOR.....	332	Reports on Elementary Schools, 1885-88.....	344
IMPROVED STEAM APPARATUS FOR HEATING AND VENTILATING.....	334	The Principles of Empirical, or Inductive, Logic.....	344
BRICK FOR STREET-PAVING <i>J. G. Shea</i>	335	Home Gymnastics for the Well and the Sick.....	345
A FIVE-MASTED SAILING-SHIP.....	336	AMONG THE PUBLISHERS.....	345
ELECTRIC-LIGHTING STATIONS IN EUROPE, AND THEIR LESSONS.....	337	LETTERS TO THE EDITOR.	
NOTES AND NEWS.....	338	Magnetic Storms and their Astronomical Effects <i>A. E. Dolbear</i>	347
EDITORIAL.....	342	Chrome Yellow considered as a Poison <i>Wm. Glenn</i>	347
THE SEVENTH ANNUAL REPORT OF THE DIRECTOR OF THE UNITED STATES GEOLOGICAL SURVEY.....	342	A Mound in Calhoun County, Ill. <i>Cyrus Thomas</i>	349
TWELFTH ANNUAL REPORT OF THE NEW JERSEY STATE BOARD OF HEALTH.....	343	New Sources of Heat <i>Henry M. Howe</i>	349

THE "PILOT CHART" of last month contained a small telegraph chart (reproduced in *Science* of April 5) of the Bay of North America, to illustrate the admirable facilities that exist for the establishment of a more complete system of telegraphic weather-reports and storm-warnings for the benefit of commerce, to include Mexico, Central America, the West Indies, and the Windward Islands. A hurricane chart accompanying the "Pilot Chart" for May, with the tracks of a few hurricanes selected as typical of those that occur in this region, illustrates still more strikingly the importance of this project, besides containing information of value to navigators during the coming hurricane season. The recent terrible disaster at Samoa, March 16, caused by a tropical cyclone, may well call attention to the fact that West Indian hurricanes are among the most severe that occur anywhere in the world. Every consideration of expediency, economy, and common sense, urges the importance of taking full advantage of every possible facility for getting early and reliable information regarding the formation and progress of these terrific storms, for the benefit of commerce along the Atlantic and Gulf coasts, and in the West Indies, the Caribbean Sea, and the Gulf of Mexico. The completion of the Nicaragua Canal will add tenfold importance to this subject, but its importance to American commerce is already so great that such a system should be in full operation now.

THE SEVENTH ANNUAL REPORT OF THE DIRECTOR OF THE UNITED STATES GEOLOGICAL SURVEY.

EVER since the foundation of the present United States Geological Survey, its scope and fitness to accomplish the great work intrusted to it, have grown, its work thus steadily gaining greater economic and scientific importance. It would be useless at the present day to dwell upon the value of geological work, to the appreciation of which the people of the United States have fully awakened. Even the people of the Western States, who are so entirely guided by practical considerations, acknowledge their necessity by appropriating funds for geological investigations or by maintaining geological surveys.

The lack of trustworthy maps has compelled the United States Geological Survey to include this indispensable preliminary work in its operations, and the great and important work is furthered with commendable energy. Ever since the first of the topographic sheets were printed, and since they have become accessible to the public, the demand for such maps has increased, and the lack is more sorely felt in regions where they do not exist. The publication of the map of New Jersey, the first of the States that can boast of a good map, and the imminent completion of the map of Massachusetts, will greatly help to bring home to the public the necessity of providing for the publication of the maps of the whole country. In the year 1886, considerable portions of New Jersey and Massachusetts, of the Appalachian region, of Kansas and Missouri, a portion of Texas, a small part of Arizona, and several valleys of California, were surveyed, and the mapping of the Yellowstone National Park was completed.

Regarding the scope of the geological work of the survey, the following passage of Major Powell's report will be read with interest: "The Geological Survey inherited much unfinished work of different surveys in the Western Territories, previously prosecuted under the auspices of the government. Since it seemed desirable to carry forward and complete these surveys as rapidly as possible, investigations were continued in the fields covered by them, and thus the early organization of the survey was determined in part by antecedent geologic work. At the same time, however, demands for local geologic and mineralogic investigations came from various portions of the country, including the older and long settled States; and, as soon as the legality of such action was established, the geologic operations of the survey were extended into the other States, and a number of divisions were organized, and intrusted with the investigations.

"It should be explained that by its organic law the Geological Survey is inhibited, both implicitly and directly, from making a geologic survey upon a cadastral plan; i.e., from making investigations relating to the value of properties of individuals. Accordingly, its work in economic geology is limited to the observation and mapping of the formations within which mineral resources lie; the general distribution and characteristics of coal-beds, ore bodies, and other valuable mineral deposits; and the investigation of questions relating to the origin and taxonomic relations of the formations themselves and of their contained minerals.

"Within the above limitations it has been found possible to make the scientific investigation of the survey of high economic value (1) by extending its operations into those portions of the different States in which the natural resources have not yet been fully developed, and (2) by developing and applying such systems of classification of the formations as will at the same time enable and compel the geologist to discriminate in the field, and clearly distinguish on the maps of the survey those rock-masses which are economically important. Both of these means of rendering these investigations of the survey of maximum value to the country have been adopted. Moreover, friendly relations exist between the United States Geological Survey and the geologic surveys prosecuted under the auspices of different States of the Union; and in many cases partial co-operation with these States has been effected in such manner that the State geologists leave to the federal survey the investigation of such general scientific questions as involve operations beyond the limits of their own States as well as within them, and avail themselves of the results of this investigation, and in return permit the general survey to utilize the results of their own more strictly economic studies."

We cannot enter into a detailed description of the work in the various divisions of the geological branch of the survey which cover extensive portions of the United States. Professor R. Pumpelly continued his researches on the archæan geology of the New England States; Mr. G. K. Gilbert, those on the Appalachian region. Of considerable practical as well as scientific interest, are Professor N. S. Shaler's researches on the swamps of the Atlantic coast. It is estimated that there are 100,000 square miles of coastal lands in the country, which, subject to inundation by tidal and fluvial waters, are valueless in their present condition. It would appear, from the experience of other countries, that, by the employment of proper methods, these lands might be reclaimed, and rendered among the most valuable of the agricultural lands of the United States. But the relative altitude of land and sea is not constant: in some places the ocean is encroaching upon the land, and elsewhere the land is emerging from beneath the oceanic waters; and even where the level of the coastal land is stationary, the shores are undermined and eaten away by the waves, and thus the sea gains upon the land in another way. The examination of the causes of the changes of coast-line must, in some cases, precede engineering operations for reclaiming land. Connected with these questions of oscillation of the land and the formation of coastal marshes, is that relating to the origin and distribution of the bog ores, phosphatic beds, etc., now in process of formation in the marshes of the Atlantic coast, and embedded in the cenozoic formations thereof, constituting one of the most important of the mineral resources of the Atlantic States.

Other important branches of the geologic division are the surveys of the copper-bearing rocks of the Lake Superior region, Professor T. C. Chamberlin's investigations on glacial geology, and the various Western surveys.

The present report is accompanied by a number of important papers, each illustrative of another part of the work of the survey. Professor T. C. Chamberlin treats the rock-scorings of the great ice invasions; Mr. Joseph P. Iddings describes the structure and petrographic character of Obsidian Cliff in the Yellowstone National Park. The classification of the early Cambrian and the pre-Cambrian formations is the subject of a paper by Mr. R. D. Irving. Professor William Morris Davis's paper on the structure of the triassic formation of the Connecticut valley gives a preliminary sketch of the work done by the archæan division, in charge of Professor R. Pumpelly. The division of mining industries is represented by T. M. Chatard's paper on salt-making processes in the United States.

There are two geological monographs on limited areas: Mr. W. J. McGee's description of the geology of the head of Chesapeake Bay, and Professor N. S. Shaler's report on the geology of Martha's Vineyard. After a survey of the Island of Nantucket, Professor Shaler undertook an investigation of the Island of Martha's Vineyard, and the results of this work are embodied in the present monograph.

He found that the front of the ice during the last glacial period remained for some time on the Island of Nantucket. After the disappearance of the ice, the region was suddenly elevated above the level of the sea, after having been depressed below its level during the continuance of the glacial conditions. Since that time it has undergone a depression of about twenty feet. From Professor Shaler's investigation on Martha's Vineyard, it appears that the tertiary beds of that island belong to a great delta deposit accumulated during the middle and later stages of the tertiary age; they have been subjected to a considerable amount of dislocation by the action of mountain-building forces; they thus indicate the action of these forces at a much later date than any for which they have been observed elsewhere on the eastern shore of the continent. Among the interesting studies incident to this inquiry is that of a boulder train originating in a hill having a diameter transverse to the motion of the ice of less than one thousand feet. Professor Shaler found that it has a fan-like shape; being, at a distance of fifteen miles from the point of origin, not less than eighteen thousand feet in width.

The report is printed and illustrated as beautifully as all the preceding reports. In the brief space allotted to us we can do no more than call attention to some of the important contributions contained in it. The fortunate combination of work that is of sci-

entific and economic value, which is characteristic of our Geological Survey, cannot fail to bring home to the minds of the people the necessity of work of this kind and its eminent usefulness to the public good.

TWELFTH ANNUAL REPORT OF THE NEW JERSEY STATE BOARD OF HEALTH.

In addition to the valuable and suggestive report of the secretary, Dr. E. M. Hunt, this volume contains the following articles: I. "The Sanitary Necessity for the Control of the Construction of Dwellings," by Henry Mitchell, M.D. In support of the ground which he takes, that there is such a necessity, the writer refers to the fact, that, of two hundred houses examined in Chicago in which diphtheria existed, but four were perfect in their sanitary arrangements. The same has been found true in other cities. He claims, that, by the loss of life in New Jersey from diseases which are preventable, the State loses annually \$5,576,000; if consumption is added to this list, the amount would reach \$12,000,000. A satisfactory organization for health-protection could be made at an expense of fifty cents per capita of the population. II. "Our Charitable and Penal Institutions," by Ezra M. Hunt, M.D. In this paper Dr. Hunt describes the condition of the almshouses, jails, etc., of the State, and makes suggestions for their improvement. III. "Water-Supply from Wells, in its Relation to Health," by Francis A. Wilber, M.D. The writer of this paper discusses (1) the source of supply of well-water; (2) its collection; (3) the sources of its impurities; (4) nature's means for removing such impurities, and the failure of these means; (5) the relation between these impurities and public health. He says that absolutely pure water is one of the greatest luxuries of modern life; and nothing in our modern civilization marks more strongly public enlightenment in matters of health than does the interest now being taken in the subject of water-supply for towns and cities. IV. "Ice as a Source of Disease," by William K. Newton, M.D. Several instances are given in which ice was the cause of sickness. Dr. Newton says that it has been abundantly proved that the use of ice cut from streams, ponds, or lakes polluted by sewage or organic refuse of any kind, is dangerous to health. V. "The Water-Supplies of New Jersey," by A. Clark Hunt, M.D. In this paper the writer gives the population of the principal towns and cities of the State, the number of houses contained therein, the source of the water-supply, the size of the reservoirs and of the water-pipes, the daily consumption and the character of the water. VI. "Diseases of Workers in Textile goods," by Drs. J. W. Stickler and J. B. Stubbart, and Mr. F. B. Lane. This is a continuation of the inquiry into State industries, which has been carried on by the State board for a number of years, to the value of which we have frequently referred.

The secretary, in an introduction, well says that it is the high duty of the State to see to it that those upon whom it must depend for productive labor are enabled to pursue that labor without undue peril to health and life; hence all machinery should be properly guarded, all factories should be examined by those expert in detecting the causes of ill health or undue exposure, and those of younger age should be protected from kinds and degrees of work unfavorable to full development and to proper schooling. As a result of the inquiry into the health of those who work in woollen goods, the reporters say, that while there is a slight tendency to bronchitis, catarrh, and rheumatism, workers in wool are to be congratulated on having an occupation which is not necessarily unsafe or unhealthy. They say, however, that there is need of more care as to dust. Workers in cotton suffer from diseased conditions much more than workers in wool, owing to the large amount of dust and the overheated rooms. Of 72 employees engaged in this work, 11 had catarrh; 7, headache; 8, rheumatism; 4, malaria; 2, bronchitis; 3, sore eyes; 3, sore throat; 1, pneumonia. Rheumatism and catarrh are the prevailing diseases. VII. "Means for Preventing the Spread of Contagious Diseases in Cities," by J. C. Bayles, M.E., president of the New York Health Department. This paper describes the methods and appliances employed by the New York department, including the three hospitals for the care of contagious diseases, and the disinfecting plant. D. C. English, M.D.,

furnishes a report of the papers and discussions of the New Jersey Sanitary Association, which met in Trenton during December, 1888. Reports from local boards of health, and health laws and circulars, together with vital statistics, are also given in the report.

BOOK-REVIEWS.

Psychology as a Natural Science applied to the Solution of Occult Psychic Phenomena. By C. G. RAUE, M.D. Philadelphia, Porter & Coates, 8°. \$3.50.

THE author of this work is by birth a German, and as long ago as 1847 he published a little book in the German language which is the nucleus of the present treatise. His psychological views are those of Beneke, whom he regards as the real founder of scientific psychology. In this work, however, the author's special object has been to explain the various "occult phenomena," such as hypnotism, thought-transference, etc., which have of late attracted so much attention; and the views presented on these subjects are the result of his own researches. The earlier part of the work is simply an ordinary treatise on psychology, containing some doctrines peculiar to the school of Beneke, but on the whole traversing pretty familiar ground. The author holds that all our states of consciousness and all our mental capacities arise from two sources,—the primitive or original forces of the soul, and the stimuli of the external world; the primitive forces, as he is careful to tell us, comprising nothing but the powers of sense. These primitive forces he also divides into two classes,—those that have been modified by external stimuli, and those that have not been thus modified, and which he calls void, unoccupied primitive forces. These forces and stimuli together he calls "mobile elements," by which we suppose he means active elements. These, then, being the sole sources of knowledge and mental power, the problem is to explain by means of them the occult phenomena in question. Dr. Raue holds that physical causes are wholly inadequate to the purpose, and that nothing but psychical forces will account for the facts. The soul he defines as "an organism of psychic forces externalizing itself in the organism of material forces which constitute the body. . . . The psychic forces are spaceless. . . . They act where they are, and yet apparently on objects far away in space, because for them there exists no space" (p. 522). But how is the action of one soul upon another, as in thought-transference, suggestion, etc., to be accounted for? Dr. Raue devotes many pages to the discussion of this subject; but it seems to us that he gets lost in a cloud of words. Here is the essence of his doctrine, which the reader can judge for himself. "The nature of thought-transference consists essentially in the excitation of the modification in the recipient similar to the one excited in the agent, and is effected by mobile elements, and principally by primitive forces partially modified or charged with external stimuli. Void primitive forces determine the concentration of the mind to the modification which is to be transferred. The mobile elements (as all soul-forces are spaceless) do not move in the sense of corporeal forces from place to place: theirs is an attraction of like to like, independent of corporeal distances or interpositions" (p. 400). We cannot think that Dr. Raue has solved the problem of the occult phenomena; but there are things in his book, nevertheless, that will interest not only special students of this subject, but also general students of psychology.

Reports on Elementary Schools, 1852-1882. By MATTHEW ARNOLD. Ed. by Sir Francis Sandford. New York, Macmillan. 12°. \$2.25.

We have here the various reports that Mr. Arnold from time to time made as an inspector of schools. They are, of course, written in his usual excellent style, and contain many remarks of more than merely temporary and local interest. Every thing statistical or of transient importance is omitted, so that the matter presented relates entirely to the general principles of education, subjects of study, methods of teaching, and other topics in which educators everywhere are interested. Mr. Arnold's district at first comprised most of the midland counties of England and a large part of Wales, but schools controlled by the Anglican and Roman churches were not under his charge. At a later time he had the oversight

of all classes of schools, but only in a small district consisting of Westminster and its neighborhood. Mr. Arnold was evidently not well impressed with the character of most of the schools, and he complains of the slow progress they made. He speaks of the low degree of mental culture prevailing not only in the lower schools, but also among candidates for the teachers' training-schools, all of whom were eighteen years old or over. This lack of general culture he attributes to the want of true literary training; and he affirms that all the literary culture the mass of English school-children get is the ability to read the newspapers,—a remark which, we fear, is applicable to other countries than England. He strongly recommends the study of English grammar and analysis, on the ground that "grammar is an exercise of the children's wits; all the rest of their work is in general but an exercise of their memory." Besides grammar, he would teach what the Germans call *Naturkunde*, or the leading facts and laws of nature, with geography and national history; this programme being intended for pupils not over thirteen years of age. He deprecates the evils that result from cramming for examination, some of which he predicted in advance. He seems to have had a keen eye for every thing connected with the schools, attending even to the form of the desks, the cleanliness of the rooms, etc. The book presents no theories of importance but such as readers of Mr. Arnold's other works are already familiar with; but it contains much that will be interesting to educators.

The Principles of Empirical, or Inductive, Logic. By JOHN VENN. New York, Macmillan. 8°. \$4.50.

THIS work contains the substance of lectures which the author has been giving for some years past to his pupils at Cambridge University. It is a discussion rather than a treatise; and the reader must be already familiar with the rudiments of logic, both inductive and deductive, in order to understand it. It is mainly devoted to induction, though there is a chapter on the theory of the syllogism, and other chapters on weights and measures, the possibility of a universal language, and other topics not really belonging to logic. The principal fault of the book is a tendency to trifling distinctions and over-subtle refinements of thought. For instance, Mr. Venn calls attention to the fact that in some departments of investigation, especially in social affairs, our own acts have an influence on the phenomena we study; and he maintains that this is true in all departments. Even the astronomer, he says, by moving to and from his instrument and by the movements of his hand in making his calculations, alters the position of every body in the universe. Again, he inquires whether we can drop a stone twice in the same spot, and answers the question in the negative, because, even if we could hold the stone in exactly the same position the second time, and at the same height, the weight and temperature of the air would be altered, and, anyhow, the moon and stars would not be in the same position as before. The book contains a great number of these hair-splitting distinctions; and, though a few of them may have some scientific importance, the great mass are hardly more than curiosities of thought.

But, in spite of this tendency to over-subtlety, the book is an able one, and professional logicians in particular will find in it much food for thought. Mr. Venn's standpoint is essentially that of Mill; but he goes rather beyond Mill in maintaining the merely probable character of all truth obtained by induction, and he uses the term "empirical" in the title of his book for the purpose of emphasizing this view. His theory of causation is the same as Hume's; while as to the methods of induction he adopts the views of Mill with but little variation. As regards the syllogism, he differs from Mill, holding that it really gives us new knowledge. He has some interesting remarks on hypothetical and disjunctive propositions, and advances a theory of disjunctives that is, we believe, new; and, though we can hardly agree with it, it is well worthy of attention. In his concluding chapter, Mr. Venn discusses the logic of morality and the moral sciences, on which he has some important remarks. He calls attention to the fact that investigations in social matters, and especially predictions as to what will happen, are more or less vitiated by the fact that the course of events will depend in part on what the investigator himself may choose to do, and that in the case of men of genius this influence of the indi-

vidual counts for a great deal. Moreover, he makes the acute remark, that, even if we could succeed in predicting the actions of men, the mere publication of our predictions would probably lead them to act differently. The chapter on these subjects is one of the best in the book. With regard to the general character of induction and the principles on which it is founded, we are not in agreement with Mr. Venn, nor do we think that any one has yet given us the true theory; but we trust that no one who studies the subject will overlook this able work.

Home Gymnastics for the Well and the Sick. Ed. by E. Angerstein and G. Eckler. With many woodcuts and a figure-plate. From the 8th German ed. Boston and New York, Houghton, Mifflin, & Co. 8°. \$1.50.

THIS book is intended, as its title implies, to instruct members of the home circle how to exercise in order to preserve health, or, if perchance they are sick, how to restore health in so far as any restoration is possible through the judicious use of exercise. Only such movements are described as can be made intelligible by descriptions and drawings, for the very object of the book is to enable one to do without a teacher. In the first division of the work the effect of bodily exercises, and rules for the practice of gymnastics, are given. After describing the beneficial effect of exercise on the muscular system, the author directs attention to its effect on the nervous system, a point which is apt to be overlooked. He truly says, that, of all parts of the organism, the nervous system occupies the first rank, inciting and guiding, at it does, all the performances of the body. A healthy nervous system is a fertile soil for the growth of a normal mental and spiritual life; and, while the use of gymnastics creates conditions which develop the nervous system, it has the power at the same time of exercising a wholesome effect on mind and spirit, and in many special cases of depression, hypochondria, and melancholia, may effect a cure. He further calls attention to the fact that the power of attention and of quick volition develops eventually into a capacity of quickly grasping new situations, and of quickly re-acting on given incitements; in other words, alertness, determination, and presence of mind are developed. The general rules for the practice of gymnastics are well chosen, concise, and practicable. In them the best time for taking exercise, the proper manner of dressing, and simple forms of apparatus, are described. In the second division the author considers gymnastic exercises at home, including movements of the head and neck; exercises for the trunk, arms and hands, legs and feet; walking, running, and jumping. The third division deals with the application of the exercises to healthy persons during babyhood, childhood, the school age, adolescence, maturity, and old age. The application of the exercises for invalids is thoroughly described, and those who have any physical trouble which can be remedied by judicious exercise will find specific directions for its employment. The book is well and sufficiently illustrated, and is by far the best work of the kind with which we are acquainted.

AMONG THE PUBLISHERS.

"THE Insane in Foreign Countries; An Examination of European Methods of Caring for the Insane," by the Hon. William P. Letchworth, president of the New York State Board of Charities, was recently published by G. P. Putnam's Sons, New York and London. To the physicians and managers connected with the institutions for the insane, and to all interested in the care and welfare of the mentally diseased, this book will prove serviceable and instructive. The introductory chapter comprises a brief historical survey of the treatment of the insane in various countries from the earliest times to the present day. Then follow chapters devoted to the lunacy systems of England, Scotland, and Ireland, and to representative institutions of these and continental countries; and a chapter each is given to the remarkable insane colony of Gheel and to the noted asylum at Alt-Scherzbitz, near Leipzig, which latter illustrates the combined excellences of a colony and a hospital. The final and longest chapter presents a *résumé* of the author's observations, and his conclusions drawn from them. Based upon

the results of his inspections of foreign and American asylums, and of his own experience in the supervision of the defective classes of New York State, Mr. Letchworth offers his views as regards the selection of sites and locations of asylums, the kind of buildings to be provided, the questions of sewage-disposal, water-supply, protection against fire, the laying-out of the grounds, the furnishing and decoration of wards and rooms, the difficult problem of the disposition of the acute, the chronic, and the criminal insane, the practice of restraint and the amount of liberty that may be granted, the character of the attendants to be chosen, the religious exercises, amusements, employments, dress and clothing, visitation and correspondence of patients, *post-mortem* examinations, the question of voluntary admission, the methods of admission and discharge, and the value of summer resorts. Besides these, the author gives his personal views respecting the insane in poorhouses, local or district care of the insane, State care, the boarding-out system, State supervision, and kindred topics. The book is beautifully printed, and richly illustrated with engravings and heliotype reproductions of plans of buildings and asylum interiors, and pictures of historical interest.

— Messrs. Longmans, Green, & Co. will shortly publish the life of C. B. Vignoles, an English civil engineer, who was assistant surveyor in South Carolina in 1817-20, and who surveyed and mapped Florida a little later. He aided Ericsson in building the "Novelty" as a rival to Stephenson's "Rocket," and he became one of the foremost of English railway engineers.

— Lord Randolph Churchill is one of the English politicians in whom Americans take an interest for various reasons. His speeches, collected, edited, and annotated by Mr. Louis J. Jennings, formerly of *The New York Times*, have just been published by Longmans. In his introduction, the editor sketches Lord Randolph's political career, and draws a piquant parallel with that of Lord Beaconsfield.

— Ginn & Co. announce in their Classics for Children Series "The Two Great Retreats of History," to be ready in May. This volume contains Grote's "History of the Retreat of the Ten Thousand Greeks from Babylonia," and an abridgment of Count Ségur's "History of the Retreat of Napoleon from Moscow." The two works stand in striking contrast to each other: one as the story of a great success; the other, of unexampled failure. Both are ably written, Ségur's having been translated into nearly every European language, and both convey important historical lessons to all who desire to know not only what man can do, but also what man can endure. Each narrative has an introduction, and is supplemented with a map and all needed footnotes. This firm also announces "Heroic Ballads and Poems" in preparation.

— The April number (No. 42) of the Riverside Literature Series (published monthly at 15 cents a number by Houghton, Mifflin, & Co., Boston) contains Emerson's "Fortune of the Republic," and other American essays. These essays, besides their literary merit, have a historic interest; and three of them were delivered in times of great political excitement, — "American Civilization," at Washington, in January, 1862, in the presence of President Lincoln, some months before the issuing of the Emancipation Proclamation; "The Emancipation Proclamation," in Boston, in September, 1862; and "Abraham Lincoln," at the funeral services consequent upon President Lincoln's assassination, held in Concord, April 19, 1865. Of the other two essays, "The Young American" was delivered in Boston in 1844, and "The Fortune of the Republic," in the Old South Church, in 1878.

— The May number of the *Magazine of American History* brings information of "Washington's Historic Luncheon in Elizabeth," with pictorial attractions, including a sketch of the Boudinot mansion, in which the luncheon took place; portraits not before published of some of Washington's contemporaries who were present; with engravings of pieces of the china table-service and silverware that were used. The same table-service, in perfect preservation, was placed before President Harrison at the luncheon given in his honor the day of his arrival in New York City, April 29, 1889. The second chapter of the number, "Oak Hill, the Home of President Monroe," is also from the pen of the editor, and

is illustrated. The third contribution, "Indiana's First Settlement," by the Hon. E. A. Bryan, president of Vincennes University, is on the beginnings of the State of Indiana, with portraits of George Rogers Clark and François Vigo. Then follows "The Harrison's in History," by Mrs. Ella B. Washington, an account of the President's family; "The Historic Quadrille," by Gen. John Cochrane, pointing out the historic idea which seems to have been so little understood by the public at large; "Reminiscences of Mrs. Bradford," the daughter of Hon. Elias Boudinot, who was one of the ladies of the Washington circle, by J. J. Boudinot; "Slavery in Connecticut," by Charles M. Andrews; and "Louisburg, 1745-Bunker Hill, 1775," by Nathan M. Hawkes.

—The *International Record of Charities and Correction* has been removed to Springfield, Ill., where the publishing details will hereafter be under the charge of the Rev. F. H. Wines, with whom the plan of the *Record* originated, and who has from the outset been its editor. The suspension of the *Record* for the last four months has been caused by the fact that it had not succeeded in securing sufficient support to return the cost of its publication, which has resulted in a considerable deficit, that has now been met by the voluntary contributions of its friends. The plan and the execution of the *Record* have been very warmly commended by the best authorities, and the successive numbers have been cordially welcomed by a certain circle of readers interested in the special subjects to which it was devoted; but the support for it, even on the part of those directly concerned in reformatory work, was much smaller than had been looked for by Mr. Wines and by those who had associated themselves with him in the undertaking. The valuable editorial services of Mr. Wines have been contributed entirely without compensation, and at no little personal sacrifice. Mr. Wines proposes to continue the publication at Springfield, which will enable him to deliver to the subscribers, at an early date, the num-

bers required to complete the current volume; and it is his hope to receive such further encouragement from the public as may warrant him in continuing the publication without further break, and may enable him to secure for the *Record* a permanent place as the recognized organ of the charity-reform interests of the country.

—The April issue of *The Trained Nurse* (consecrated to those who minister to the sick and suffering in hospital and home) contains articles on "The Relation of Hospitals to Medical Education," "Insanity, its Causes and Cure," "Articles for the Mother's Use," "Health in our Homes," "Asepsis for the Nurse," besides considerable other editorial and original matter. The monthly Hospital Supplement contains hospital news from all parts of the world. The Lakeside Publishing Co., Buffalo, N.Y., are the publishers.

—A. D. F. Randolph & Co. have ready an interesting literary contribution to the anniversary celebration, in Mr. Thomas E. V. Smith's volume, "The City of New York in the Year of Washington's Inauguration, 1789."

—Roberts Brothers have just ready "Ethical Religion," a volume of lectures delivered by W. M. Salter before the Society of Ethical Culture of Chicago; and a revised edition of C. E. Pascoe's useful handbook, "London of To-Day," which is now in its fifth year.

—Houghton, Mifflin, & Co. will publish shortly another contribution to the growing Emerson literature. The forthcoming volume is by the son of the sage of Concord, Mr. Edward W. Emerson, who will afford a glimpse into the domestic life of his father. The title of the book will be "Emerson in Concord." Houghton, Mifflin, & Co. have also under way an illustrated edition of Thackeray, which will be, it is promised, more complete than any other existing edition. It will be in twenty-two 12mo volumes printed in large type.

ONE LANGUAGE FOR THE WHOLE WORLD.

WORLD-ENGLISH:

THE UNIVERSAL LANGUAGE. 25 CENTS.

EVERY one has heard of the butcher who, after a long search for his knife, at last found it in his mouth; so speakers of English have been seeking for a universal language, when lo! it is in their mouths. The intelligibility of English words has been obscured by a dense mist of letters. This is now dispersed by A. Melville Bell, who has already won a world-wide reputation through his invention of "Visible Speech," the great boon to deaf-mutes. Professor Bell calls this new discovery of his "World-English," and the result is a language which cannot fail to meet with acceptance, and at once supersede the supposed necessity for "Volapük," or any other artificial language. No language could be invented for international use that would surpass English in grammatical simplicity, and in general fitness to become the tongue of the world. It is already the mother-tongue of increasing millions in both hemispheres, and some knowledge of the language is demanded by all educated populations on the globe. Social and commercial necessities require that the acquisition of this knowledge shall be facilitated, and it is believed that Professor Bell's invention has removed the last impediment to English becoming the universal language, for which vague desires have long been entertained, although hitherto only futile efforts have been made.

Ex-President Andrew D. White, of Cornell University, says: "I believe that the highest interests of Christian civilization and of humanity would be served by its adoption. China and Japan would be made English-speaking peoples within fifty years, and so brought within the range of Christianizing and civilizing ideas, in the largest sense. All existing missionary work is trivial as compared with this. For your system would throw wide open those vast countries, as, indeed, all the countries of the world, to the whole current of English and American thought."

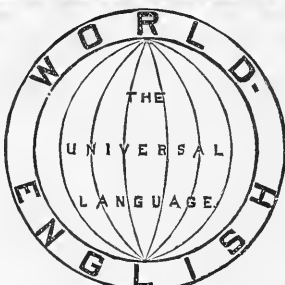

For Diffusion of English throughout the World

AS
THE UNIVERSAL LANGUAGE

This "Hand-Book of World-English" is the Complete, Simple, and Efficient Medium.

FOREIGNERS

Will Acquire, by Means of this Hand-Book, a
PERFECT PRONUNCIATION OF ENGLISH.

For Primary School Pupils and Illiterate Adults

World-English is a Royal Road to Reading.

To Teachers of English and Modern Languages

This Hand-Book will be of Primary Importance

as a Phonetic Directory.

DEFECTS OF SPEECH

Will be Readily Corrected by Means of the Articulate Directives in this Hand-Book.

HAND-BOOK OF WORLD-ENGLISH,

25 CENTS.

The plan of this little book is altogether new. Letters and sounds are so associated, in all the exercises, that from the mere knowledge of letters a learner cannot fail to pronounce words with certainty. English reading will thus be easily acquired, whether by natives or foreigners, children or adults.

The general resemblance of World-English to Literary English is such that any reader of the latter decipheres the former at sight, or, at most, after a few minutes' study of the new letters. A like result may be anticipated for those who shall learn to read from World-English. They will transfer their power of reading to the literary form of the language, almost without effort. The orthographic aspect of words will, besides, be so fixed in the eye, by contrast, that spelling will be remembered as — what it really is — a pictorial association with words.

No special training is required to qualify teachers for using this book. The subject can even be successfully introduced in the kindergarten and the nursery. This phonetic mode of initiation in reading cannot be too strongly urged on the attention of School Boards on both sides of the Atlantic.

The ordinary orthography of each word is interlined with the World-English version throughout the Exercises and Readings.

So set down, our tongue is the best for the world to unite upon.—*Brooklyn Eagle*.

The idea of Mr. Bell has much to recommend it, and the presentation is charmingly clear.—*American*, Philadelphia.

The result is a language which cannot fail to meet with acceptance.—*Boston Traveller*.

Has the merit of great ingenuity.—*Railway Age*.

His treatise, as a study of English orthoepy, condenses the result of much thought and experience in small compass.—*The Critic*.

World-English deserves the careful consideration of all serious scholars.—*Modern Language Notes*.

World-English is the English language unburdened of its chaotic spelling.—*Popular Science Monthly*.

We commend it to the attention of teachers.—*Ottawa Globe*.

"World-English" and "Hand-Book of World-English" can be had of all booksellers, or will be sent for 50 cents, post free, by the publisher.

N. D. C. HODGES, 47 Lafayette Place, New York.

LETTERS TO THE EDITOR.

Magnetic Storms and their Astronomical Effects.

THE earth is sometimes spoken of as a great magnet. Its magnetic condition, however, is not constant, but varies within rather wide limits. Some of the changes are periodic, while others are spasmodic and irregular. The sunspot period appears to be in some way related to the changes in the earth's magnetic condition; for, at the time when the spots are at their maximum in number, the so-called magnetic storms are most frequent and violent. There is a general agreement among meteorologists that the magnetic changes observed upon the earth are in some obscure manner due to the influence of the sun.

In meteorology, as elsewhere, when other explanations are unavailable, resource is found in electricity, especially so if electrical phenomena can be in some manner discovered to be involved; and this happens to be the case in a very great number of phenomena, not as causes, but as effects. Not infrequently it happens that some of the best-known laws of electricity are ignored, or are confounded with other laws of other forms of energy. This seems to be precisely the case in this phenomenon.

In his article upon meteorology, in the last edition of the "Encyclopædia Britannica," Balfour Stewart says, "We are thus driven to look to the upper regions of the earth's atmosphere as the most probable seat of the solar influence in producing diurnal magnetic changes; and it need hardly be said that the only conceivable cause capable of operating in such regions must be an electric current. Now, we know from our study of the aurora that there are currents in such regions, continuous near the pole, and occasionally in lower latitudes." And yet a little further on he argues very properly that more knowledge seems to be needed before we can assert that there are currents of electricity in regions where conduction is impossible.

Now, a current of electricity always implies conduction, and conduction implies molecular contact. We are abundantly able to prove this: for with such vacua as can readily be produced, say, the millionth of an atmosphere, not only will electricity not traverse it, but even Crookes's phenomena cease. At the height of a hundred miles, the average free path of the molecules is measured by feet; and this renders it as certain as any thing we know in physics, that electrical currents are impossible there, and hence, whatever may be the explanation of the magnetic changes in the earth, they are not due to currents of electricity in those high regions.

Still the earth is a magnet. It has its poles, though these change their position. The bulk of the earth with which we are acquainted is made up of non-magnetic matter, having varying degrees of conductivity; the rocky part being very poor, while the oceans and moist soils are conductors to such a degree as to permit commercial use for telegraphic and other purposes, thus saving the cost of a return conductor. The larger part of the surface of the earth is, then, an electrical conductor. Whenever a conductor of electricity is rotated in a magnetic field, an electrical current is the result; and such current is maintained so long as the rotation is continued, the strength of the current depending upon several variables, the strength of the magnetic field, the degree of conductivity, and the rate of rotation.

That electrical currents are continually traversing the crust of the earth, has been established, since the telephone has provided us with an instrument delicate enough for observation, and employed by so many all over the earth.

To be sure, it was known before that earth-currents were sometimes present, for upon occasions they were so strong as to interfere with or stop telegraphic communication. Such interruptions were generally coincident with auroral displays, but sometimes occurred in the day-time, when auroral effects could not be seen if they chanced to be present. As these earth-currents have been found to be coincident with both magnetic disturbances and with spasmodic solar action, — for several observers have noted solar eruptions at times when the magnetometers gave evidence of magnetic changes in the field, and in one or two cases even determining that the rate of transmission of the sun's action was the same as that of light, — it follows that the earth acts as if it were rotating in the magnetic field of the sun.

If the sun be considered as a magnet, then its field extends to an indefinite distance in space, and the earth must be rotating in it; and, so far as the earth is a conductor, there should be currents in it: in fact, just what we discover. So far, the electricity is an effect, and not a cause, magnetism being the preceding physical state.

A conductor moving in a magnetic field in such a manner as to have electrical currents generated in it always suffers retardation of its motion, as is illustrated by letting a coin fall between the poles of a strong magnet, — a property utilized in modern galvanometers to bring the needle quickly to rest. Such currents are technically known as "Foucault's currents," and the energy they represent is at once transformed into heat in the conductor. The electricity is but the transient state intermediate between the retarded motion and the rise in temperature. This series of physical relations — viz., the rotation of a conductor in a magnetic field, the retardation of the motion, the electrical current, and the final transformation into heat of original energy of the mechanical motion — is a well-ascertained series of effects, which is universal; and thus it follows, that, so far as the earth has currents of electricity set up in it by the sun's action, so far its rotary motion is retarded, and also its temperature is increased, both effects not hitherto recognized so far as I know. Of course, the retardation of motion is very small indeed, but it must be taking place, and in time will bring the earth to a standstill. What the amount may be, there appears to be no way of determining, because there is no way of ascertaining the strength of the earth's currents, nor the earth's resistance, nor the strength of the magnetic field of the sun.

Furthermore, the retardation of other bodies in the solar system may be traced to the same physical conditions instead of frictional resistance of the ether, which has sometimes been hypothesized.

Lastly, if the magnetic condition of the earth varies, it follows that the magnetic field of the earth varies, and all bodies in that field are re-acted upon by it. The gases of the atmosphere at high altitudes have free paths comparable with those in Crookes's tubes, and might fairly be expected to exhibit similar phenomena if electrified and in a changing magnetic field. Their electrification need not be much of an assumption, when one considers what happens in a thunder-shower. Rotating molecules, if conductors of electricity, ought to have Foucault's currents in them when in a magnetic field, and they should therefore be heated. As there is no chance for conduction of the heat, the rate of vibration increases till incandescence is reached. The only way in which the molecule can unload its extra energy is by radiation.

The motions seen in auroras may thus be due to the changes in the magnetic field of the earth instead of to electrical currents circulating in the high air.

A. E. DOLBEAR.

College Hill, Mass., April 23.

Chrome Yellow considered as a Poison.

THE object of this note is to spread wide the facts that chrome yellow is a poison, and that its use in food-stuffs is by no means rare.

The cases reported up to this time, in which toxic action is assigned to lead chromate and to chrome yellow, — bodies which apparently all writers consider as identical, — are many more than a hundred. Seemingly the first report is to be found in the *Medical Times and Gazette* of Dec. 24, 1859, in which are set forth the cases of six school-lads who were seriously poisoned by eating Bath buns. These latter were shown to contain each "seven grains of chromate of lead," which had been used as coloring-matter in lieu of eggs. All of the six lads are stated to have recovered.

In 1874, Von Linstow was next to assign toxic action to these bodies. He attributed to them the deaths of two children, within his own practice, who had eaten possibly seven artificial bees which had served to ornament a cake. Each of these bees had been colored by about four milligrams of "neutral lead chromate." The cause of death was destruction of the coats of the œsophagus and stomach, with puncturing of the intestines. The cases are reported in Eulenberg's *Vierteljahrsschrift f. ger. Med.*, N.F. XX., and

are mentioned as being a part of the literature of the subject. They are entirely discredited by the later work of Stewart, of Marshall, and of others, all of which will be mentioned later.

In 1882, R. C. Smith printed an account of more than fifty cases of poisoning among English mill-operatives who had breathed the dust of lead chromate given off from yellow dyed yarn in process of manufacture. The cases occurred in his own practice and in that of his co-workers, and authentication is complete. The effect was chronic lead-poisoning, clearly developed. This account, so important and interesting, is but a brief statement of bare fact. It is to be found in the *British Medical Journal*, 1882.

Five years before the publication of Dr. Smith's paper, Leopold (*Vierteljahrsschrift f. ger. Med.*, N.F. XXVII. 29) published an account of a babe which he stated had died from breathing lead-chromate dust from yellow dyed yarn. The cause of death is assigned to softening and perforation of the coats of the stomach, — an opinion to which Leopold, apparently, was bent by the cases of Von Linstow, already cited. As we now know quite surely that lead chromate is not at all a corrosive poison, we must so far discredit Leopold's case. In the same account he states that four adults who breathed the same dust incurred chronic lead-poisoning. He was therefore first to trace that kind of effect to the breathing of lead-chromate dust, and for that work we cannot offer him too much thanks.

The report of Smith is followed chronologically by the admirable work of Dr. D. D. Stewart of Philadelphia, the early history of which is to be found in the Philadelphia daily papers of July, 1887, and in the office of the coroner of that city. A few months previously, Dr. Stewart had found some cases of lead-poisoning, which, through tenacity of purpose, he finally traced to bakers' stuffs as the cause. He secured in a bakery the chrome yellow with which these stuffs had been colored, and showed that the baker himself was a physical wreck from eating his own wares; and, moreover, that several members of his family had died of lead-poisoning, brought about by eating the chrome-yellow colored stuffs. This latter was proven by the bodies exhumed by the coroner, who investigated altogether fifteen deaths. The work was done by Deputy Coroner Powers, who, in an interview at his office on Sept. 10, 1887, told the writer that it was a small estimate to put at two hundred the people in Philadelphia who had died of lead-poisoning induced by bakers' stuffs. The causes of death, he said, had been certified to various diseases, among them malaria and cerebrospinal meningitis, but that now all physicians agreed that they were cases of lead-poisoning.

One who had examined the mortuary records informed the writer that others of these deaths were assigned to typhoid, typhus, epilepsy, Bright's disease, and to lepto meningitis. The real causes were established by Dr. Henry Leffmann, who analyzed the viscera of the exhumed bodies. The victims had died of lead-poisoning. During the coroner's investigations, it was shown that the use of chrome yellow by bakers as a coloring-matter was quite common. At an inquest held July 11, 1887, the evidence of Dr. Miller of the firm of Aschenbach & Miller, dealers in colors, was "that he believed that eighty per cent of the bakers in the city" used chrome yellow in certain of their bread-stuffs. In February of the following year, two of these bakers were sentenced to terms of imprisonment. The courts appear to have been lenient because the bakers themselves had been so distressed by the poisoning. One of them had lost a wife and five children, and was himself a wreck.

The discovery of the cause of so much suffering and death in Philadelphia is due to Stewart alone; and no less to him is due the action taken by the officers of the law towards the victims and the criminals.

The clinical history of Dr. Stewart's cases may be found in the *Medical News* of three dates: 1. June 1887, under the title "Notes on Some Obscure Cases of Poisoning by Lead Chromate;" 2. Dec. 31, 1887, "Clinical Analysis of Sixty-four Cases of Poisoning by Lead Chromate (Chrome Yellow) used as a Cake-Dye;" 3. Jan. 26, 1889, "Poisoning by Chrome-Yellow used as a Cake-Dye: A Subsequent Clinical History, etc." The literature of the subject has nothing at all comparable with these papers. In this field the author stands easily first among his brothers.

The chemical and pathological sides of the subject have lately

been worked out, with painstaking and in the scientific spirit, by John Marshall, M.D., of Philadelphia. His paper is to be found in the *Therapeutic Gazette* for Feb. 15 of the present year. His experiments were made upon dogs, to which he fed pure lead chromate in various quantities, up to eighty-four grams. Careful analyses were made of the products of decomposition going on in the living animals, and finally autopsies were performed upon their bodies. The experimenter found that lead chromate had been decomposed in the bodies of the living animals, and that lead and chromium had been absorbed, and that in all cases "the stomach showed no evidence of corrosion." This work of Dr. Marshall is altogether excellent. No epitome of it could do it justice, and of course the workers in this field will read the original paper. It is proof positive that lead chromate could have produced all the effects which Stewart insists it did produce, in his cases.

The work so well done by Marshall suggested itself to the present writer at the time of the newspaper publication of Stewart's cases, and dogs were selected for the experiments. But it was put a stop to by two discoveries: (1) that the writer did not possess the knowledge requisite, and (2) that chrome yellow of commerce was not lead chromate. This latter discovery arose out of the analyses of various samples from many manufacturers, a few of the results being as follows:—

No. of Sample.	Lead Chromate.	Lead Sulphate.	White Lead.	
1	66.38	28.83	x	
2	32.52	18.82	47.04	Samples analyzed as received, and no account taken of moisture.
3	60.77	11.90	24.38	
4	14.47	20.81	60.95	
5	58.10	36.24	x	
6	26.79	68.84	x	

No. 1 was obtained in open market, and bore the name of distinguished manufacturers. It was marked "Pure Precipitated."

No. 2 was given the writer by Dr. Henry Leffmann, before mentioned. It was part of a sample submitted by the coroner of Philadelphia to his jury sitting upon one of the poisoning cases unearthed by Stewart.

Nos. 3, 5, and 6 were from a manufacturing chemist in Baltimore who wanted pure lead chromate, and who undertook to obtain it from among his correspondents. These three samples were certified as perfectly pure.

No. 4 was given the writer by Dr. Miller, from out of the stock of Messrs. Aschenbach & Miller, who as merchants were concerned in the Philadelphia chrome-yellow cases. It was kindly submitted as being of the kind used by the bakers concerned in Stewart's cases.

The samples given in the above table are selected as being typical of good commercial chrome yellow. Efforts continued through nearly a year did not result in finding a single sample of lead chromate sold as chrome yellow.

Having ascertained that commercial chrome yellow consisted of lead chromate with lead sulphate, and with white lead frequently, it followed that such a compound could produce lead-poisoning, and certainly would if taken into the stomach during any length of time. There could not exist, therefore, any doubt as to the correctness of the views of Stewart, so far as concerned the source of poisoning.

Shortly after newspaper publication of the Philadelphia cases, the writer bought and examined in Baltimore several samples of yellowish bakers' stuffs. None of them contained lead. But there was no such result with certain kinds of candy. There was to be had in two of the Baltimore public markets an abundance of candy made from glucose, and colored by chrome yellow. With the view of stopping its sale, one of the city papers agreed to collect candy samples by means of its reporters, and cause them to be analyzed. This was done, and on the first day of search five samples were bought in two of the markets. Four of the five contained chrome yellow in quantity from 0.199 per cent to 0.319 per

cent. The analyses are to be found in the *Baltimore American* of April 22, 1888, and are signed by the writer and his co-worker, Dr. William Simon. Both of us had repeatedly bought in the markets, and together had analyzed, similar candy with the same results. The quantity sold in a market on a market-day apparently was not less than ten nor more than thirty pounds. We have preserved samples of the material, and shall be glad to divide them with workers in this field. Such candy, consumed in such quantities, cannot have failed to produce in Baltimore an abundance of lead-poisoning.

From all this we deduce the following conclusions: that lead chromate breathed as dust, or taken into the digestive apparatus, produces lead-poisoning; that commercial chrome yellow ingested with food-stuffs produces more quickly the same result; that chrome yellow is a mixture of lead chromate and lead sulphate, to which frequently is added white lead ($2 \text{ Pb CO}_3 + \text{Pb H}_2\text{O}_2$); that none of these substances are corrosive poisons; that bakers' and confectioners' products not infrequently are colored with chrome yellow, and often are sources of lead-poisoning, which may exist largely in a community and yet escape detection. WM. GLENN.

Baltimore, April 26.

A Mound in Calhoun County, Ill.

MR. MIDDLETON, one of the assistants of the Bureau of Ethnology, has recently excavated quite a number of mounds in Calhoun County, Ill., among them one presenting some features of special interest. The following description is taken from Mr. Middleton's field-notes.

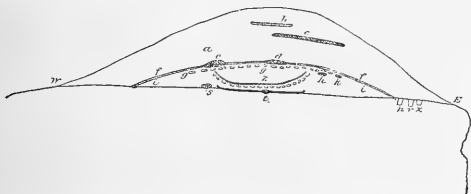

This mound, which forms one of a group of five located on the spur of a bluff about one hundred and fifty feet high, overlooking the Illinois River, stands at the brink of a precipice. It is conical in form, and ninety-five feet in diameter at the base.

As the internal structure is the most interesting feature, a figure is given showing a vertical section, in which *W-E* indicates the line of the natural surface of the bluff, as well as the direction of the section.

"From the top downward to the depth of fourteen feet," says Mr. Middleton, "we passed through a layer composed chiefly of yellow clay (*a*) obtained from the surrounding surface of the bluff. Near the centre, at the depth of four feet, was a horizontal bed (*b*) of hard gray earth, — apparently muck from the river, — eight inches thick, and covering an area about twenty feet in diameter. Three feet lower was a bed (*c*) of burnt clay about the same thickness and extent as the preceding. Although particles of charcoal were mixed through it, no ashes were observed on or about it.

"At the depth of fourteen feet we reached what seems to have been the nucleus or original mound, over which the heavy mass of clay had been cast at some subsequent period. Over this lay a thin covering of whitish material (*f, f*), apparently light ashes, not more than two inches thick, and extending on all sides to the original base. This rested, for the most part, on a single layer of stones (*g, g*), the latter lacking several feet of extending to the outer margin. Examining carefully the stones which formed this layer, evidences of weathering on the upper side were distinctly visible, showing that the mound must have remained undisturbed at this height for a considerable length of time. The thin stratum of ashes over it seems to confirm this view, as the charred stems of grass near the outer margin show that this was produced by burning a covering of grass which had grown over it. The dark spots (*d* and *e*) indicate two small fire-beds resting on the layer of stones.

"Removing the stones, and cutting a trench through the low, broad, original mound or nucleus to the natural surface of the bluff, we found the construction to be as shown in the figure, — an oval basin (*z*), ten by thirteen feet in extent and three feet deep, lined throughout with a layer of stones similar to those above. It was filled with the yellow surface soil of the ridge. The stones, which bore very distinct marks of weathering, were covered with a thin layer of white ashes mixed with charred leaves and grass. Under the stones, and resting on the natural surface of the ridge, was a thin layer of decayed vegetable matter. The slopes (*z-z'*) surrounding the basin were of yellow clay similar to that of the thick upper layer of the mound. The dark spots (*d* and *e*) are small fire-beds.

"Partly under and partly in the bottom layer of decayed vegetable matter, and exactly in the centre of the mound, was a single skeleton (*t*) lying on the back at full length, the feet to the south; but the head was wanting. Not a tooth, or particle of the jaw or skull, was to be found, though careful search was made. As all the other bones were well preserved and comparatively sound, except that the pelvis and some of the ribs were broken, I presume the head must have been removed before burial. This is the second instance I have observed in which the head was removed before burial. The first was dug up at Pecan Point, Arkansas.

"Six feet south of the centre of the mound was a small deposit of burned bones (*s*), lying on the natural surface of the bluff. Seven feet west of the centre, lying on the original soil, were the remains of an infant. It had been doubled up until the knees touched the chin, wrapped in a grass covering, and placed upon its left side.

"A shell-shaped vessel at the right shoulder of the large skeleton, and a shell, were the only specimens found in the mound. The latter was in a stone box or cist two feet and a half square and one foot deep, resting on the natural surface of the ridge. Not a fragment of bone was found in this box.

"Another singular feature observed consisted of three small pits (*u, v, x*) under the eastern base of the upper layer. These were three holes, from fifteen to eighteen inches in diameter, and one foot deep. One of them contained particles of rotten wood. There were several intrusive burials in the thick upper clay layer, which presented nothing of special interest."

It is apparent, from Mr. Middleton's figure and description, that we have in this tumulus a specimen of the Ohio "altar-mound" type, possibly a prototype. What he calls the nucleus or original mound is beyond question one of the so-called "altars" of the type described by Messrs. Squier and Davis, and is one more item of evidence that the Ohio mound-builders came from the West, as I have contended elsewhere.

CYRUS THOMAS.

Washington, D.C., April 23.

New Sources of Heat.

IF, as I take it, the communication of your correspondent "X," on p. 329 of your issue of April 26, is intended as a sort of exposure, it is to be warmly welcomed.

What Mr. Blodget has actually done, I cannot say; but that his assertions are extremely inaccurate, I know. He states that "in all cases where a powerful blast is applied to the limited area of a melting-furnace . . . the degree of heat generated is greatly in excess of the theoretical yield of the number of pounds of coal consumed." This is absolutely untrue. On the contrary, measurements of the heat actually developed under these conditions agree surprisingly closely with the "theoretical yield of the number of pounds of coal consumed." This is well exemplified in Bell's calculations and measurements of the heat developed in the blast-furnace.

Mr. Blodget's statement that this excess of heat generated over the theoretical yield of the coal is particularly great in the Bessemer converter, is a case of astonishing ignorance, or, as I prefer to believe, of extreme carelessness in the use of words. I supposed that every reader of *Science* knew that no carbonaceous fuel was burned in the Bessemer converter (except, of course, in heating the converter between operations). A new Keely motor seems to be born. *Caveat emptor.*

HENRY M. HOWE.

Boston, April 29.

INDUSTRIAL NOTES.

THE Thomson-Houston Company has been obliged to greatly increase their facilities in order to handle their rapidly increasing business in electric railways. In addition to the large contracts which they closed some time ago, they have lately closed the following: Lynn and Boston Railroad Company, Nahant Line, which has 4,300 feet of track, two turnouts, maximum gradient of four per cent, the line extending from Central Square, Lynn, to Nahant House, Nahant: one car will be put in operation at first, the power for which will be obtained from the station of the Lynn Electric Light Company. Newburyport and Amesbury Horse Railway Company, Newburyport, Mass., which line is about six miles in length, and will operate two cars: it is made up almost entirely of curves and grades, the maximum of which is ten per cent; the cars will be operated by a current from the Newburyport Electric Light Company, Newburyport, Mass., and also from the Amesbury Electric Light Company, Amesbury, Mass. The Newton Circuit Line, Newton, Mass., which will operate ten cars, and is eight miles in length: it will run from Newton to Watertown on the West End track, and on new track from Watertown to West Newton and Newtonville. The Plymouth and Kingston Railway Company, Plymouth, Mass., which line is four miles in length, and will operate three cars, the maximum gradient being six per cent: this line will run from Chiltonville, through Plymouth, to Kingston, and on nearly all of the line the bracket method will be used; the track is about laid. The Quincy Street Railway, Quincy, Mass., which line will operate four cars, and is five miles in length, extending from Quincy, through Wollaston Heights and Atlantic, to the Neponset River; the bracket method of overhead construction will be used. The company has also received orders for new cars from the Wheeling Railway Company, Wheeling, W.Va.; West End Street Railway Company, Boston, Mass.; Topeka Rapid Transit Company, Topeka, Kan.; Omaha and Council Bluffs Railway and Bridge Company, Omaha, Neb.; Lynn and Boston Street Railway Company, Lynn, Mass. The company has also constructed a track of about one mile for the Hillside Coal Company of Scranton, Penn., on which a forty-horse-power locomotive is used. This is used for carrying coal, and is capable of hauling about twenty cars loaded with one ton each.

—The Thomson-Houston Electric Company report the following sales of stationary motors: 7.5 horse-power, Walker & Pratt Manufacturing Company, Boston, Mass.; 1 horse-power, J. R. Kelly, Providence, R.I.; 10 horse-power, Georgia Electric Light Company, Atlanta, Ga.; 10 horse-power, Master-Builders' Association, Boston, Mass.; 1 horse-power, A. Harris, Providence, R.I.; 1.5 horse-power, Bonschur & Holmes, Philadelphia, Penn.; 3 horse-

power, H. W. Ladd, Providence, R.I.; 1.5 horse-power, W. Shedley, Providence, R.I.; 10 horse-power, J. J. Hillman, Boston, Mass.; 15 horse-power, Garfield & Proctor Coal Company, Boston, Mass.; 1 horse-power, Cambridge Shirt Company, Cambridgeport, Mass.; 1.5 horse-power, A. C. Manchester, Providence, R.I.; 1.5 horse-power, New Bedford Gas Company, New Bedford, Mass.; 3 horse-power, C. F. Heptonstall, Providence, R.I.; 1 horse-power, B. F. Haley, Dover, N.H.; 1.5 horse-power, John M. Sweeney, Wheeling, W.Va.; 3 horse-power, B. L. P. Martin, Providence, R.I.; 5 horse-power, T. C. Entwistle, Lowell, Mass.; 15 horse-power, Minot Estate, 30 Court Street, Boston, Mass.; 20 horse-power, Whittier Machine Company, Boston, two motors for elevators; 5 horse-power, Thomson-Houston Electric Light and Power Company, Buffalo, N.Y.; 10 horse-power, Wales Manufacturing Company, Syracuse, N.Y.; 5 horse-power, St. Catherines Electric Railway Company, St. Catherines, Ont.

—The Thomson-Houston Electric Company reports the following sales of arc and incandescent lamps: Adams, Mass., 45 arc; Falls City Jean and Woolen Mill, Louisville, Ky., 200 incandescent; Sanford Woolen Mills, Medway, Mass., 100 incandescent; Stearn & Silverman, Wheeling, W.Va., 20 arc; Monroe County Insane Asylum, Rochester, N.Y., 600 incandescent; Moore Building, Syracuse, N.Y., 200 incandescent; Saxon Woolen Mills, Franklin, Mass., 200 incandescent; New Haven, Conn., 45 arc; New England Company, Bath, Me., 300 incandescent; Washington Court-House, O., 50 arc; Buffalo, N.Y., 190 arc; Cambridge, Mass., 1,000 alternating; Lowell, Mass., 1,000 alternating; Hudson River Street Hospital, Poughkeepsie, N. Y., 800 incandescent; Leominster, Mass., 50 arc, 600 alternating; Bedford, Penn., 50 arc, 600 alternating; Leicester, Mass., 600 alternating; Stamford, Conn., 1,500 alternating; Hudson, N.Y., 45 arc; Fernandina, Fla., 50 arc; Portland, Me., 45 arc; New Decatur, Ala., 50 arc; Manchester, N.H., 100 arc; Chester, Penn., 30 arc; Revere, Mass., 600 alternating; H. W. Smith, Bangor, Me., 50 incandescent; Findlay, O., 1,000 alternating; T. J. Stewart, Milo, Me., 50 incandescent; Woonsocket, R. I., 1,000 alternating; Riverside and Oswego Mills, Providence, R.I., 400 incandescent; Pitman, Mass., 500 alternating, 50 arc; Morse Whyte, Cambridge, Mass., 200 incandescent; Rockland, Me., 30 arc; Jewell Milling Company, Brooklyn, N.Y., 200 incandescent; Savannah, Ga., 250 arc; James Walker & Co., Basin Mill, Mo., 50 incandescent; Malden, Mass., 500 alternating; Fort Payne Coal and Iron Company, Fort Payne, Ala., 400 incandescent; Upper Sandusky, O., 60 arc; J. B. Mason, Providence, R.I., 50 incandescent; Columbus, Ga., 1,000 alternating, 100 arc; Thomasville, Ga., 50 arc; Perry Painé Building, Cleveland, O., 1,000 incandescent.

OUR CENTENNIAL EXHIBIT.

Many of those who regularly read advertisements of our goods in these columns, will be in New York city during Centennial Week. We hope to see them here in the store.

For a few days, immediately preceding and following the great Military and Civic Parades, each department in the house will make a special decorative display of its goods.

Having, beyond question, one of the largest and most varied assortments of High Novelty Dress Fabrics to be found in America, we expect to make this Exhibit memorable, and in every way worthy of the time in which it occurs.

JAMES McCREERY & CO.
BROADWAY AND ELEVENTH STREET,
NEW YORK.

A TEMPORARY BINDER

for Science is now ready, and will be mailed postpaid on receipt of price.



Half Morocco - 75 cents.
This binder is strong, durable and elegant, has gilt side-title, and allows the opening of the pages perfectly flat. Any number can be taken out or replaced without disturbing the others, and the papers are not mutilated for subsequent permanent binding. Filed in this binder, Science is always convenient for reference.

N. D. C. HODGES,
47 Lafayette Place, N. Y.

ESTABLISHED 1859.

H. A. DREW,
Commercial Printer,
5 Clinton Place, near Broadway,
New York.

Wedding Orders, Souvenirs, Invitations, Orders of Dance, etc., etc., done in the latest and most elaborate styles, at reasonable prices. All Favors promptly attended to.

Wants.

A YOUNG MAN can have lucrative engagement, not only a fixed salary, but according to his work accomplished in travelling for SCIENCE. A personal interview invited.

N. D. C. HODGES,
47 Lafayette Place, New York.



PETER COOPER'S GLUE.

Prepared in liquid form by the N.Y. Liquid Glue & Adhesive Co. The long and well-known reputation of this glue for its strong adhesive properties requires no recommendation. It is the glue your furniture is glued with, and never fails to join the hardest of wood if properly applied. Always ready for use. For sale everywhere. CONTAINS NO ACID.

Unalterable & Fragrant
GLUE **PASTE**

A strong and harmless preparation of flour and glue for Photographers, Manufacturers, Merchants, Insurance Companies, Banks, and family and office use. Contains no acids. Unlike Mucilage, adheres and dries immediately. N. Y. Liquid Glue and Adhesive Co., Preparers of Peter Cooper's Glue in Liquid Form, 18 N. William St., New York. Used in this office.

GUARANTY INVESTMENT COMPANY

CAPITAL \$250,000.

Hon. ALBERT H. HORTON (Chief Justice, Kansas Supreme Court), Topeka, Kan., Pres't.

7% Guaranteed Farm Mortgages 7%

The Company calls the special attention of Investors to the following points :

- I. All loans guaranteed and interest payable semi-annually at the Importers' & Traders' National Bank, New York.
- II. Unusual fulness of information, not only about the security itself, but about the general development of the section where the farm is located.
- III. An examination each year of the general business of the Company and the Mortgages themselves by a COMMITTEE OF INVESTORS sent for the purpose.
- IV. Many hundred Mortgages taken and NOT A SINGLE FORECLOSURE.
- V. Exhibitions in New York at frequent intervals, of Kansas and Nebraska Farm Products. The Exhibition at the American Institute in the fall of 1888, received the *HIGHEST AWARD* of superiority.
- VI. Monthly Bulletins giving full information about all Mortgages offered for sale.

Address for Monthly Bulletin and Investors' Committee Report for 1888,

HENRY A. RILEY, General Eastern Manager, 191 Broadway, N.Y.

A BOOK FOR THE TIMES!

NEW EDITIONS!

Laidlaw's Constitution of the United States and the Declaration of Independence, in English, French, and German, with notes. Sold by all booksellers, or by the publishers, LAIDLAW BROS. AND CO., 137 W. 41st St., New York.

Second and Revised Edition, in cloth - - - - - 50c. postpaid.

Third Edition, in paper - - - - - 25c. postpaid.

Publications received at Editor's Office,
April 15-27.

- ARNOLD, M. Reports on Elementary Schools, 1882-82. Ed. by Sir Francis Sandford. London and New York, Macmillan. 302 p. 12°. \$2.25.
- BOVLSTON, P. John Charakés: A Tale of the Civil War in America. Philadelphia, Lippincott. 289 p. 12°. \$1.25.
- CLAUS, C. Elementary Text-Book of Zoology. Tr. and ed. by Adam Sedgwick and F. G. Heathcote. 2d ed. Vols. I and II. London and New York, Macmillan. 967 p. 89. \$8.
- CONNOLLY, J. H. A Storm Ashore. Chicago, New York, and San Francisco, Belford, Clarke, & Co. 92 p. 12°.
- CONVERS, D. Marriage and Divorce in the United States: As they are and as they ought to be. Philadelphia, Lippincott. 266 p. 16°. \$1.25.
- HILDRETH, C. L. The Masque of Death, and Other Poems. Chicago, New York, and San Francisco, Belford, Clarke, & Co. 168 p. 12°.
- JACOB, M. P. Physiological Notes on Primary Education and the Study of Language. New York and London, Putnam. 120 p. 12°. \$1.
- KINKEAD, A. The Queen of the Block. Chicago, New York, and San Francisco, Belford, Clarke, & Co. 57 p. 12°.
- LOGAN, C. Her Strange Fate. New York, Chicago, and San Francisco, Belford, Clarke, & Co. 268 p. 12°. 32c.
- MELDOLA, R. The Chemistry of Photography. (Nature Series.) London and New York, Macmillan. 382 p. 12°. \$2.
- MONTGOMERY, D. H. The Leading Facts of French History. Boston, Ginn. 327 p. 12°. \$1.25.
- NICHOL, J. Francis Bacon, his Life and Philosophy. Part II, Bacon's Philosophy. Philadelphia, Lippincott. 259 p. 16°. \$1.25.
- PHIN, A. Practical Guide to Success in the Use of Recipes, Formulae, etc., Technological and Commercial. New York, Industrial Publ. Co. 44 p. 16°.

16c. PAGES. THREE PAGES. 16c.

Hundred Thousand new subscribers for The Family Journal and Ladies' Companion wanted. It is the most interesting and instructive paper ever issued. Subscribers will receive during the coming twelve

MONTHS

novels written by American Authors, complete in each three numbers. The story of popular works of fiction will be retold by a novel reader, the most interesting and unique feature ever introduced in any publication, giving the substance of popular and standard books by famous writers in a space easily read by the busiest people. We have engaged

FOR

this work a widely known and popular writer. Comments on Current Events, Fashions, New and Original Ideas and Designs for Ladies' Fancy Work and Household Decoration, Letters from Correspondents and their Answers. The colleges and seminaries of the United States will be treated one each month in an illustrated article, showing the particular advantage of each, cost of attendance, etc. Invaluable to parents having sons or daughters whom they desire should receive the advantages of a higher education than the ordinary school affords. Articles on Painting and Drawing, giving home instruction by a well-known artist. A trial subscription of this elegant paper will be sent to any address, three months, for

TEN CENTS.

Liberal pay for literary work adapted to our columns, and for new and original drawings, designs and ideas on any subject which we can use. Premium List (the most complete in the world. We offer inducements to club raisers and agents approached by no other publishing house. The celebrated Gilbert Cut Waist Linens, which we send post paid to any one sending us two yearly subscribers at 50 cents each is alone worth 10 cents. Sent to any address, post paid one year, 50 cents; six months, 25 cents, and a three months' trial subscription for only 10 cents.

TRY IT! TRY IT! TRY IT!
and you will become a permanent reader. Address:

John L. Douglass, Publisher,
322 Broadway, N. Y.

"The Week, one of the ablest papers on the continent."—*Descriptive America.*

ENLARGED AND IMPROVED.

THE WEEK:

A Canadian Journal of Politics, Literature, Science and Arts.

PUBLISHED EVERY FRIDAY.

\$3.00 per Year. \$1.00 for Four Months.

THE WEEK has entered on its SIXTH year of publication, greatly enlarged and improved in every respect, rendering it still more worthy the cordial support of every one interested in the maintenance of a first-class literary journal.

The independence in politics and criticism which has characterized THE WEEK ever since its first issue will be rigidly maintained; and unceasing efforts will be made to improve its literary character and increase its value and attractiveness as a journal for the cultured home. Many new and able writers are now, or have promised to become, contributors to its columns, and the constant aim of the Publisher will be to make THE WEEK fully equal to the best literary journals in Britain and the United States.

As heretofore, PROF. GOLDWIN SMITH will, from time to time, contribute articles. London, Paris, Washington and Montreal letters from accomplished correspondents will appear at regular intervals. Special Ottawa Letters will appear during the sessions of Parliament.

THE WEEK in its enlarged form will be the same size as "Harper's Weekly," and the largest paper of its class on the continent.

SEND FOR FREE SAMPLE COPY.

C. BLACKETT ROBINSON, Publisher,
5 Jordan St., Toronto.

Readers of Science

Corresponding with or visiting Advertisers, will confer a great favor by mentioning this paper.

Schools.

The Sauveur Summer College OF LANGUAGES.

(Removed from Amherst, Mass., and Oswego, N.Y., to BURLINGTON, VT.)

The Normal Class will be taught for the French by Dr. Sauveur, for the German by Dr. W. Bernhard, for the Latin by Prof. J. U. Dillard.

Dr. Sauveur's new work, LES CHANSONS DE BERANGER, with Historical Commentary and Notes, will be ready June 1, and taught at the School.

DR. L. SAUVEUR, Copley Terrace, Roxbury, Boston, Mass. N.B.—Circulars of Dr. L. SAUVEUR Educational Works will be sent free to applicants.

CONNECTICUT, NEW HAVEN, MRS. CADY'S SCHOOL FOR YOUNG LADIES. Prepares for Smith and Wellesley, and admits to Vassar by Certificate.

NEW JERSEY, PLAINFIELD, THE CHESTNUTS.—Parents with daughters to educate, or orphan girls with companion, may find a comfortable home, with school instruction by applying to Miss E. E. Kenyon.

A NEW MAGAZINE—THE SWISS CROSS Devoted to spreading a love of nature among the people. Edited by HARLAN H. BALLARD, President of the Agrassiz Association, and succeeding St. Nicholas, as the official magazine of that body.

Any one who will have the following blank filled out by a responsible Newsdealer, and mailed to us, will be allowed a three months' subscription to Science.

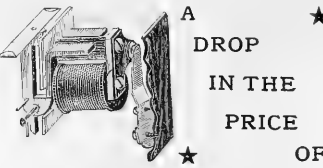

GRAVITY DROP ANNUNCIATORS.

DON'T FORGET THE DUST-PROOF BELLS.

HAZAZER & STANLEY, 32 Frankfort Street, N. Y.

N. D. C. HODGES, 47 LAFAYETTE PLACE, NEW YORK.

SCIENCE CLUBBING RATES.

Table with columns for 10% DISCOUNT, Year's Subscription, With Science, and With The Swiss Cross. Lists various publications and their rates.

To the News Company.

You may add to my regular order five copies of SCIENCE each week (returnable).

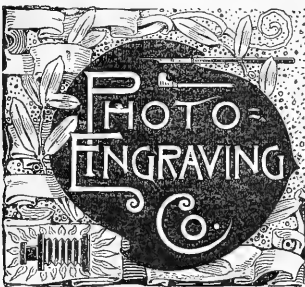

JOHN HASTINGS = Pres't. A=R=MART = Gen'l Manager. JOS=TTRIPP = V.Pres't. ENGRAVING FOR ALL ILLUSTRATIVE AND ADVERTISING PURPOSES

BRANCH AT 728 CHESTNUT ST PHILADELPHIA, PA.

67-71 PARK PLACE NEW YORK.

N. D. C. HODGES, 47 Lafayette Place, New York.

C. & C. ELECTRIC MOTOR COMPANY.

Electric Motors
FOR
Arc and Incandescent Circuits, Most Economical Motor on the Market.
Regulation Perfect.
Motors Designed for all Power Purposes.

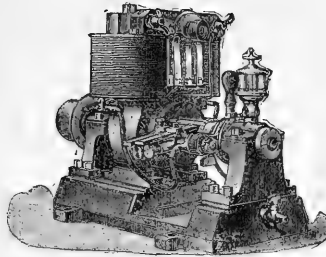

OFFICE and MANUFACTORY:
402 and 404 Greenwich Street, New York City.

New England Office, 19 Pearl St., Boston.

Philadelphia Office, 301 Arch St.

Western Office, 139-141 Adams Street Chicago.

Southern Office, 25 Carondelet Street, New Orleans.

THE

American Bell Telephone COMPANY.

95 MILK ST., BOSTON, MASS.

This Company owns the Letters Patent granted to Alexander Graham Bell, March 7th, 1876, No. 174,465, and January 30, 1877, No. 186,787.

The Transmission of Speech by all known forms of ELECTRIC SPEAKING TELEPHONES inuring the right secured to this Company by the above patents, and renders each individual user of telephones, not furnished by it or its licensees, responsible for such unlawful use, and all the consequences thereof and liable to suit therefor.

ESTERBROOK'S STEEL PENS.

OF SUPERIOR AND STANDARD QUALITY.
Leading Nos.: 048, 14, 130, 135, 239, 333
For Sale by all Stationers.

THE ESTERBROOK STEEL PEN CO.,
Works: Camden, N. J. 26 John St., New York.

Old and Rare Books.

One Million Magazines. Back numbers, vols. and sets—old and new, Foreign and American.
CATALOGUE UPON APPLICATION.

A. S. CLARK,

34 Park Row, New York City.

BACK NUMBERS and complete sets of leading Magazines. Rates low. AM. MAG. EXCHANGE, Schoharie, N. Y.

H. WILLIAMS,

Dealer in Old Magazines, Reviews, &c. Scientific periodicals a specialty. 39 Macdougall St., N. Y.

Scientific Apparatus.

J. GRUNOW,

621 Sixth Avenue, New York.
Established 1852.

MAKER OF

Microscope Stands, Oil Immersion Objectives and Abbe Condensers for Bacterial and Histological work, of Objectives, Camera Lucida and other accessory apparatus.

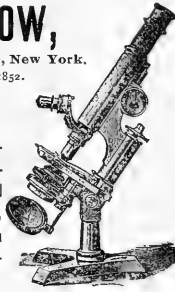

IMPROVED OIL LIGHT MAGIC LANTERNS.

Also Lime and Electric Light Apparatus, and mechanical, plain, and fine colored views.

J. B. COLT & CO., Manufacturers,
No. 16 BEEKMAN STREET, NEW YORK.

MAGIC Stereopticons and the Best Views for Public, Church, Home, and Scientific Exhibitions. Best apparatus, new views. Largest stock. Reduced prices. 24 Years' Practical Experience. Illus. Catalogue Free.

GEO. H. PIERCE,

136 S. Eleventh St., Philadelphia, Pa.

ELECTRICAL TESTING BUREAU,

Johns Hopkins University, Baltimore, Md.

Resistance Coils and Boxes Compared. Am meters and Volt meters calibrated. Condensers standardized. Primary and Secondary Batteries Tested. Efficiency of Dynamos and Motors Determined.

Insulation of Cables and Wires Tested.

Etc., Etc.

Circulars describing Methods Used, Prices, Etc., sent on Application.

Address as above.

MORRIS EARLE & CO.

SUCCESSORS TO

R. & J. BECK,

1016 Chestnut Street Phila

Microscopes and all Accessories and Apparatus. Photographic and Photo-Micrographic Apparatus and Outfits.

Spectacles, Eye Glasses, Opera and Marine Glasses, etc.

Illustrated Price List mailed free to any address. Mention SCIENCE in corresponding with us.



E. & H. T. ANTHONY & CO.
591 Broadway, N. Y.

Manufacturers and Importers of PHOTOGRAPHIC INSTRUMENTS, Apparatus and Supplies of every description. Sole proprietors of the Patent Detective, Fairy, Nov. 21, and Bicycle Cameras, and the Celebrated Stanley Dry Plates.

Amateur Outfits in great variety, from \$3.00 upward. Send for Catalogue or call and examine. More than 40 years established in this line of business.



GOOD NEWS TO LADIES.

Greatest inducements ever offered. Now's your time to get up orders for our celebrated Teas and Coffees, and secure a beautiful Gold Band or Moss Rose China Tea Set, Dinner Set,

Gold Band Moss Rose Toilet Set, Watch, Brass Lamp, or Webster's Dictionary. For full particulars address THE GREAT AMERICAN TEA CO., P. O. Box 239, 31 and 33 Vesey St., New York.

R. ELLIS & CO.

BUSINESS, HOTEL AND PATENT BROKERS,

AUCTIONEERS, ETC.

No. 176 BROADWAY,

Room 46.

New York.

CLIENTS Advised free of charge.

CALIGRAPH

MEDAL AWARDED!
GREATEST SPEED ON RECORD!!

126 words per minute, errors excluded.

T. W. Osborne, winner of international contest at Toronto, wrote on the Caligraph Writing Machine 630 words in five minutes, thus gaining for the Caligraph the championship of the world.

30,000
in
Daily Use.

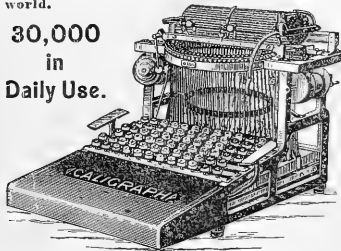

For full and correct account of above test, address
THE AMERICAN WRITING MACHINE CO.,
HARTFORD, CONN.
New York Branch, 237 Broadway.

PARIS EXPOSITION.

The Cheque Bank issues Cheques, either singly or put up in Books, for the special use of VISITORS to the PARIS EXPOSITION, who can cash them the same at upwards of seventy Banking Houses, situated in different parts of Paris, without charge.

Visitors' mail matter can be addressed to them, Care of the Societe Generale, 4 Place de l'Opera, opposite the Grand Hotel, where English is spoken. Every Cheque that is issued by the Cheque Bank is EQUAL TO CASH, as Bank Notes are, for the Bank's Capital, Guarantee Fund and Customers' Balances are invested in British Government Securities, or held in Cash in the Bank of England, and can be cashed in every town in Europe without charge.

For Handbook containing list of 2,500 Banking Houses who cash the cheques, free of charge, apply to

CHEQUE BANK, Limited,
Capital, £100,000. Guarantee Fund, £27,000.
Trustees, The Right Honorable John Bright, M.P.,
The Right Honorable Earl Beauchamp.
NO. 2 WALL STREET, NEW YORK.

Visitors to Europe and Paris Exposition should carry a book containing Cheque Bank Cheques, which are absolutely safe and cheaper than Letters of Credit, and much more convenient; are payable on presentation without charge at 2,500 Banking Houses and 250 of the principal Hotels in Europe.

FOOD ADULTERATION

And its Detection. With photomicrographic plates and a bibliographical appendix. By J. P. Battershall. 328 pages, 8vo, cloth. Price, \$3.50. Circulars and Catalogues on application. E. & F. N. SPON,
12 Cortlandt St., New York.



KIMBALL'S STRAIGHT CUT CIGARETTES.

Unsurpassed in quality,
Used by people of refined taste.
Highest award at Brussels, 1888.
The finest smoking mixtures are of our manufacture.
Fifteen First Prize Medals.
WM. S. KIMBALL & CO.,
Rochester, N. Y.

REMINGTON STANDARD TYPEWRITER

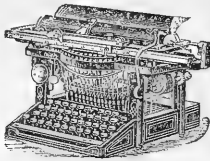

WON
Gold and Silver Medals

FOR
CHAMPIONSHIP OF THE WORLD.

At Toronto, in open contest, Aug. 13, 1888.

151 Words per Minute, Without an Error.

The above is an authentic record made by Mr. Frank E. McGurrian, at Detroit, on Jan. 21, 1889, on a memorized sentence, thus beating all previous records of correct work, by 30 words per minute and placing the "Remington" still further beyond reach of competition. Photographic copies of certified work furnished on application. WYCKOFF, SEAMANS & BENEDECIT, 327 Broadway, N. Y.

The Mutual Life Insurance Company OF NEW YORK.

RICHARD A. McCURDY, PRESIDENT.

ASSETS - - - \$126,082,153 56

The Largest and best Life Insurance Company in the World.

The New Business of the Mutual Life Insurance Company in 1888

Exceeded \$103,000,000.

Its Business shows the Greatest Comparative Gain made by any Company during the past year including

A gain in assets of	\$ 7,275,301 68
A gain in income of	3,096,010 00
A gain in new premiums of	2,333,406 00
A gain in surplus of	1,645,622 11
A gain in new business of	33,756,792 85
A gain of risks in force	54,496,251 85

The Mutual Life Insurance Company

Has Paid to Policy-holders since Organization \$272,481,839 82.

KNABE

PIANOFORTES.

UNEQUALLED IN

Tone, Touch, Workmanship and Durability.

WILLIAM KNABE & CO.

NEW YORK: No. 112 Fifth Av., above 16th St.
BALTIMORE: Nos. 22 and 24 E. Baltimore St.
WASHINGTON: No. 817 Market Space, Penn. Av., near 9th St.

PATENTS.

During April and May my fees due only on allowance if desired. Write

WM. H. BABCOCK,
513 Seventh St., Washington, D.C., P. O. Box 220.
Formerly Examiner in Patent Office.
THIRTEEN YEARS' PRACTICE.

A RARE CHANCE FOR A COLLEGE.

For sale—1,300 FINE COINS and MEDALS, silver, gold, bronze, a history in coins commencing with the fifteenth century, representing over 500 historical persons and 175 countries and cities. Address
L. D., P. O. Box 1337, New York.

IMPROVING THE MEMORY PICK

and facilitating the acquirement of knowledge by lectures and correspondence. Classes forming. "MEMORY and its Doctors," from Simonides to "Lousette," mailed for 10 cents.
DR. PICK, 24 Union Square, N. Y. City.

Readers of Science
Corresponding with or visiting Advertisers
will confer a great favor by mentioning the paper.

What Scott's Emulsion Has Done!

Over 25 Pounds Gain in Ten Weeks.
Experience of a Prominent Citizen.

THE CALIFORNIA SOCIETY FOR THE
SUPPRESSION OF VICE.
SAN FRANCISCO, July 7th, 1886.

I took a severe cold upon my chest and lungs and did not give it proper attention; it developed into bronchitis, and in the fall of the same year I was threatened with consumption. Physicians ordered me to a more congenial climate, and I came to San Francisco. Soon after my arrival I commenced taking Scott's Emulsion of Cod Liver Oil with Hypophosphites regularly three times a day. In ten weeks my avoirdupois went from 155 to 180 pounds and over; the cough meantime ceased. C. R. BENNETT.

SOLE BY ALL DRUGGISTS.

SCIENCE

[Entered at the Post-Office of New York, N. Y., as Second-Class Matter.]

A WEEKLY NEWSPAPER OF ALL THE ARTS AND SCIENCES.

SEVENTH YEAR.
VOL. XIII. No. 327.

NEW YORK, MAY 10, 1889.

SINGLE COPIES, TEN CENTS.
\$3.50 PER YEAR, IN ADVANCE.

THE WESTERN ELECTRIC INCANDESCENT LIGHTING SYSTEM.

ALTHOUGH it has not the capacity of the arc system for producing large lights, and is inferior to it in economy, the incandescent light demonstrates daily its ability to compete successfully with

soft iron, and pole-pieces are cast upon the upper ends of the cores. The lower ends of the cores are bolted to the cast-iron base: there are therefore only two magnetic joints in the whole system.

The type of field-magnet frame used in their well-known arc-lighting system is not used for this incandescent apparatus; but a simpler form, and one better adapted to this class of work, has

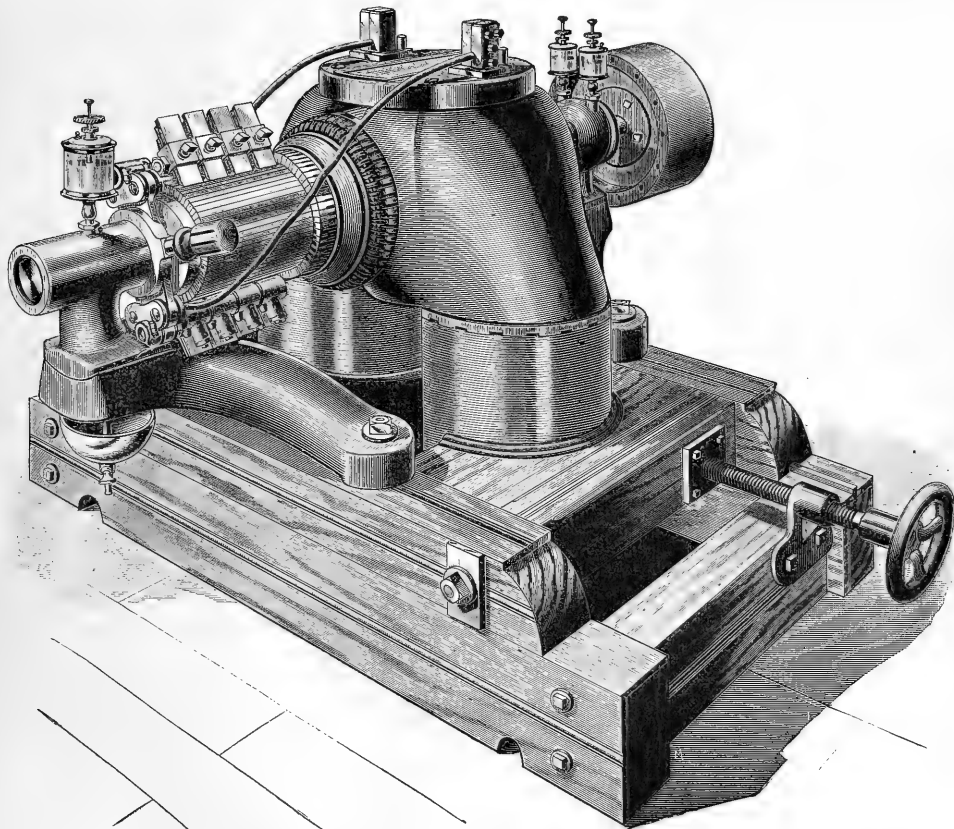

FIG. 1.—END VIEW OF INCANDESCENT DYNAMO OF WESTERN ELECTRIC COMPANY.

gas and other systems of lighting, and has supplanted gas for purposes of general illumination in many places.

Figs. 1 and 2 illustrate a complete dynamo as made for the incandescent system of the Western Electric Company, while Fig. 3 shows a field-magnet and pole-pieces only. The whole iron base is cast in one piece. The cores of the field-magnets are made of

been adopted. The peculiar form of the cast-iron base results in bringing the armature-shaft at a convenient height from the floor, but not so high as is usually the case in dynamos having this type of field-magnet, while at the same time it permits the use of the sliding carriage for adjusting belt-tension without raising the dynamo or rendering it unstable. The field-magnet coils are con-

nected, shunting the armature. The automatic regulation thus secured is practically perfect. Any number of lamps may be cut in or out without visibly affecting the candle-power or brilliancy of the lamps throughout the system.

The terminals of the thin field-wires are not exposed to injuries, as in so many systems, but are led in channels through the pole-pieces to the field binding-posts. Both these posts and the main binding-posts are mounted on a hard-wood board, which is secured

without the least heating or sparking, — a fault so common in many other systems.

Although the dynamo is automatic in its action, a variation in the speed of the engine or water-wheel might cause the lamps to burn above or below candle-power. An instrument is therefore needed to indicate at all times to the engineer or dynamo-tender whether the lamps burn at normal candle-power, or, what is practically the same, at normal electrical pressure. The voltmeter

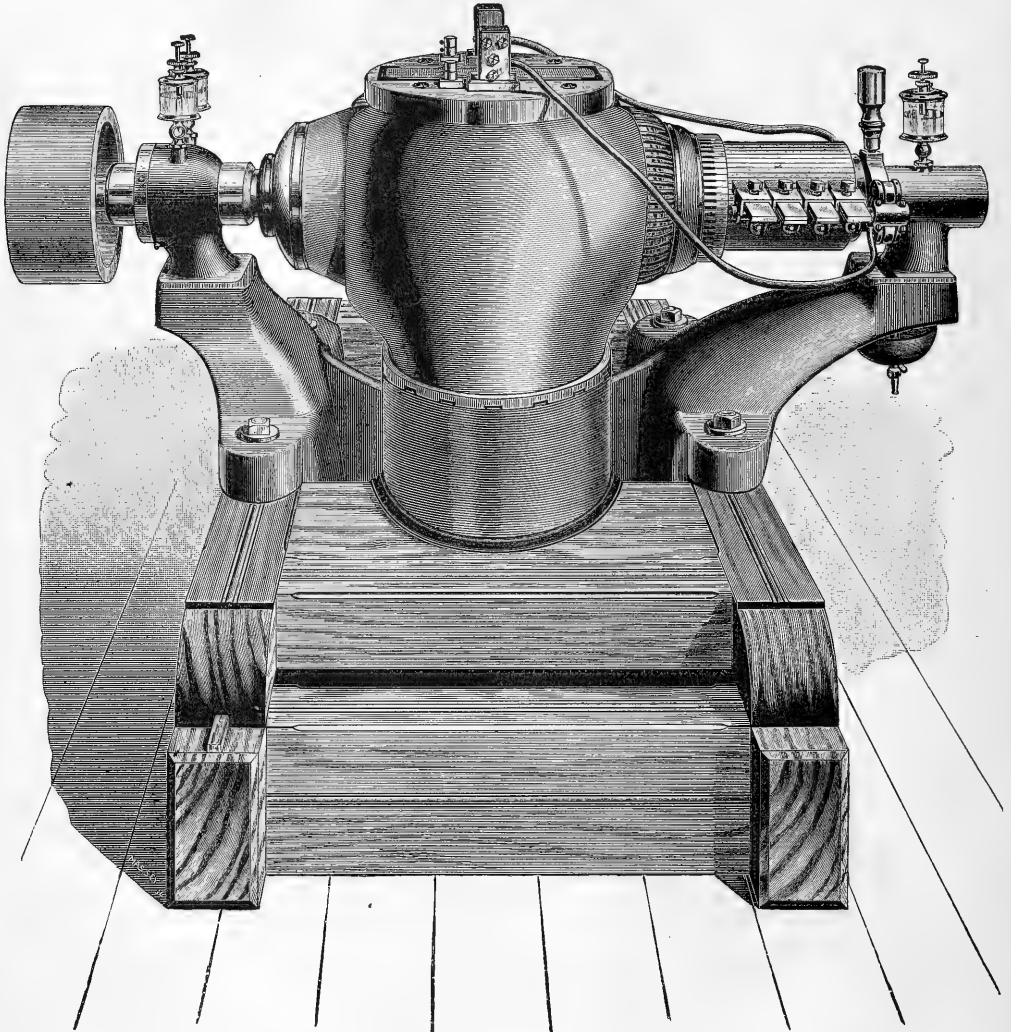

FIG. 2.—NEW INCANDESCENT DYNAMO OF THE WESTERN ELECTRIC COMPANY.

on the top of the pole-pieces. This board has an oblong slot covered with wire gauze, allowing the warm air from the armature to ascend, and at the same time preventing any thing from falling on the armature. The armature is of the drum type, and is wound in a very simple and peculiar way, avoiding all joints in the wires but two. The commutator is very massive, and will last for many years. From two to six sets of brushes, according to the size of the dynamo, carry the current from the commutator to the cables

(Fig. 4) used for this purpose is simple in construction, dead beat, and may be left in the circuit permanently without overheating. It needs no recalibration, as it has no permanent magnets, and is considered reliable.

The rheostat or hand-regulator (Fig. 5), used to keep the electrical pressure constant by increasing or decreasing the strength of the field, is non-combustible. It consists of a cast-iron frame provided with porcelain insulators, to which german-silver wire coils

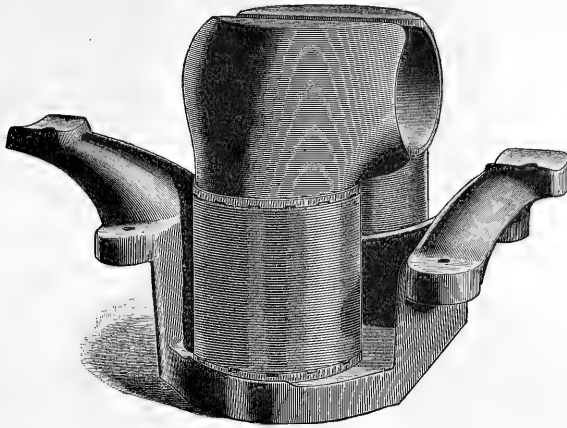

FIG. 3.

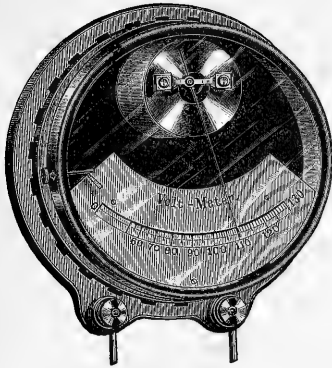

FIG. 4.

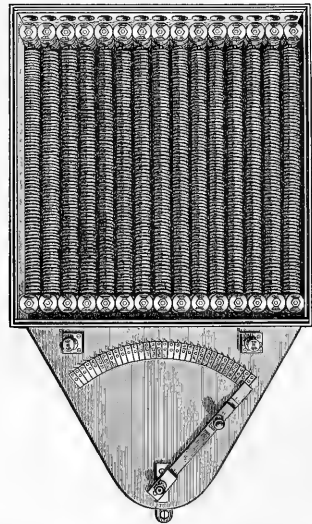

FIG. 5.

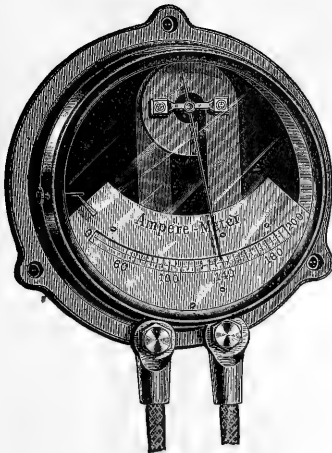

FIG. 6.

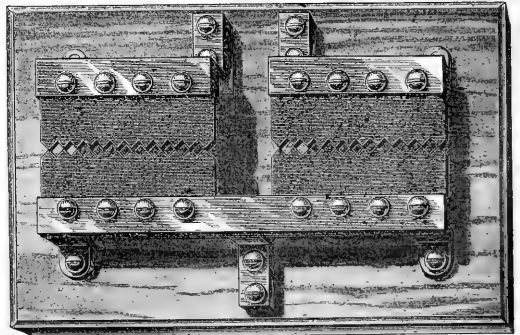

FIG. 7.

are attached. The front of the rheostat-box is covered with glass, preventing the dirt and dust from getting into the box, and at the same time allowing ready inspection.

The ampère-meter, or ammeter (Fig. 6), is an instrument to indicate the number of ampères which the dynamo is generating

Fig. 8 represents a main switch of the Western system for 150 and 300 ampères capacity.

Fig. 9 represents a multiple safety cut-out board. These boards are convenient where a number of branches terminate in a closet, and are useful to connect up a number of single cut-outs in mul-

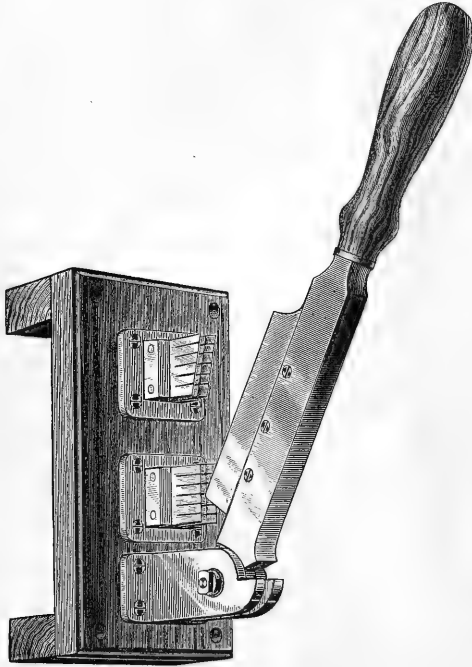

FIG. 8.

As each lamp requires a certain current in ampères, from the indications of the ammeter, the number of lamps burning may be easily computed. This may also be left in the circuit permanently without overheating.

The lightning-arrester (Fig. 7) is simple in its operation. The

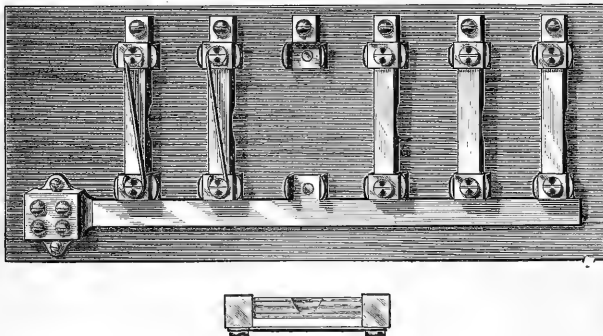

FIG. 9.

jaws of this lightning-arrester are made of carbon plates. In case the dynamo-current should follow a discharge of atmospheric electricity, an arc may be set up; but this will burn away some of the carbon points, and thus free the dynamo of the short circuit. Such a carbon lightning-arrester can, of course, only be used for low-tension dynamos.



FIG. 10.

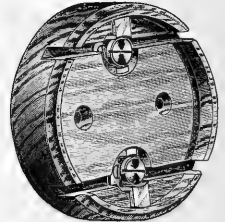
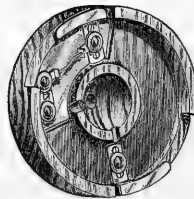

FIG. 11.

tiple arc. These boards are made for any number of circuits from four to twelve. The safety-strips may be replaced in a few seconds, and, while current is on, without danger.

Figs. 10 and 11 represent ceiling cut-outs, to be used when lamps are to be suspended by means of flexible cable.

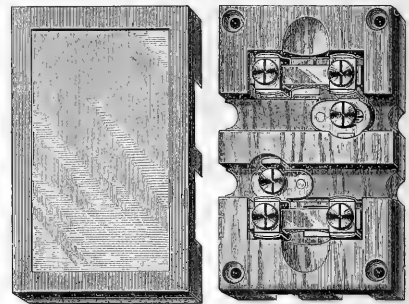

FIG. 12.

Fig. 12 represents a double pole branch-block.

WE learn from *Nature* that Dr. Schweinfurth arrived at Aden on March 23, on his return from a three months' stay in Central South Arabia. He has started for Europe, taking a very interesting botanical collection with him.

THE WESTINGHOUSE COMPOUND ENGINE.

THE American public is probably now fully prepared to accept compounding as the one and only road to the highest fuel economy in steam-engines. Compounding is almost universal among European manufacturers, extending down to engines of the smallest size, and has been forced upon them by the close margin of manufacturing profit there obtaining. The larger profits and freer methods which have ruled in this country, and particularly the great complication and prohibitive cost which follow the compounding of the ordinary automatic engine, have led to the almost universal adoption of the single cylinder.

It is not proposed to enter into a treatise upon compounding.

the terminal pressure increases; which means, that, when the steam is finally thrown away, it still has in it, say, twenty pounds of available pressure above the atmosphere, or thirty-two pounds above effective vacuum, which is a dead waste that ought to be preserved, and converted into work. If, now, we seek to lower the terminal pressure in order to waste less exhaust pressure, we not only cut down the power of the engine enormously, but at once introduce the element of excessive internal condensation in the cylinder,—a most insidious, and fatal enemy of economy. Internal condensation is due to the fact that the immediate internal surfaces of the cylinder, cylinder-heads, and piston, are subjected at each stroke to a wide fluctuation of temperature, ranging from, say 330° , the temperature of the steam admitted from the boiler, to 212° , the

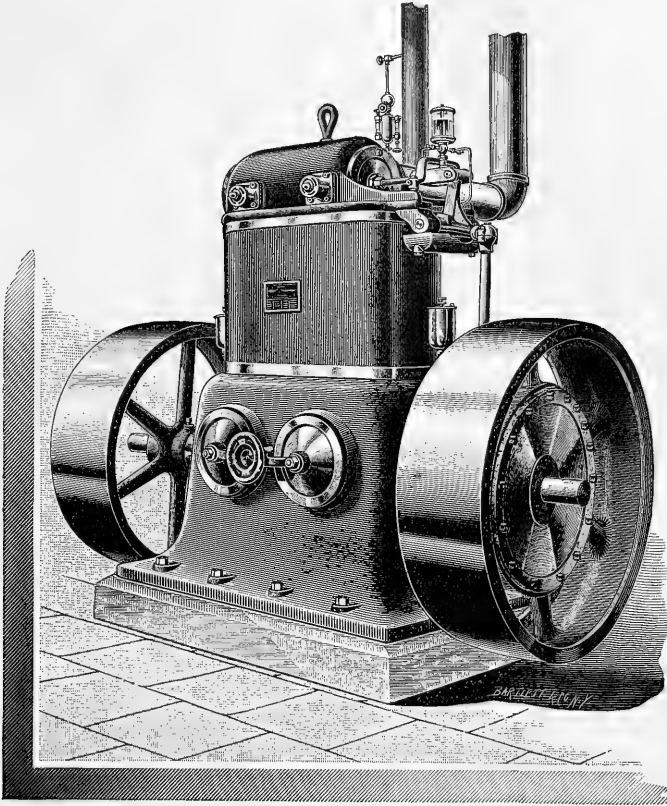

WESTINGHOUSE COMPOUND ENGINE, FRONT VIEW.

Every one knows that to compound an engine a second cylinder of three or four times the piston area is added, called the low-pressure cylinder, into which the exhaust steam of the first or high-pressure cylinder, instead of being thrown away, is passed, and made to yield a further amount of work. The additional work thus obtained is roughly proportional to the mean effective pressure in the low-pressure cylinder, multiplied by the difference in area of the two pistons. By this means the power of the engine is increased, and the steam, when finally exhausted, is at a pressure so low that less unused work remains in it. The maximum possibilities of economy are thus secured. But why cannot the same result be reached by further expansion in a single cylinder? A single cylinder, in the performance of its work, must choose between the two horns of a dilemma.

It has been found in practice that there is a certain load which is the most economical in a single cylinder. If the load increases,

temperature of the exhaust. The earlier the cut-off, the lower the terminal pressure and corresponding temperature, and the greater the amount of steam required to re-heat the surfaces: hence the greater the condensation. Hence any considerable departure in either direction from the rated power of a single-cylinder engine means a sacrifice of economy,—waste of exhaust pressure if overload, and loss from condensation if under-load. The compound engine, therefore, economizes by getting additional work out of the exhaust steam, which would otherwise be wasted; and by dividing the fluctuations of temperature between two cylinders, compelling one-half the variation to take place in each cylinder, thereby reducing internal condensation in the ratio of the squares, namely, to one-quarter of that due to a single cylinder.

For the Westinghouse compound engine, figures of which illustrate this article, it is claimed that it not only exceeds the economical performance of any single-cylinder engine, but of any other

compound engine, size for size, as well. In explanation of this, it is said that it is a high-speed compound engine, the high rotative speed tending to economy of steam by using it quick and using it hot, and to that extent reducing condensation.

Again, the relative position of the two single-acting cylinders, with the cranks opposite instead of at right angles, gets rid at once of an intermediate receiver, and the consequent loss by free expansion due to exhausting from the high-pressure cylinder into the partially emptied receiver at each stroke, which is inseparable from other forms of construction.

But more important than any other factor of economy is the almost theoretical perfection of the steam-distribution. This is the more interesting from the fact that the first step in the design of

Both practice and theory have demonstrated as a necessity to secure the maximum economy of steam, not only that exhaust compression shall exist, but that it shall be raised exactly to the initial pressure of the incoming steam at the commencement of the stroke. We say exactly, since over-compression is equivalent to non-productive load in any other form; and, still more serious, under-compression fails to restore heat to the cylinder surfaces, besides leaving the clearance volume to be filled at the expense of live steam. This is true in general of any type of engine. It is therefore necessary not only that mechanism should be provided for effecting the full initial compression above indicated, but also that this mechanism, while still maintaining compression exactly to the initial, should at the same time possess the capacity of varying

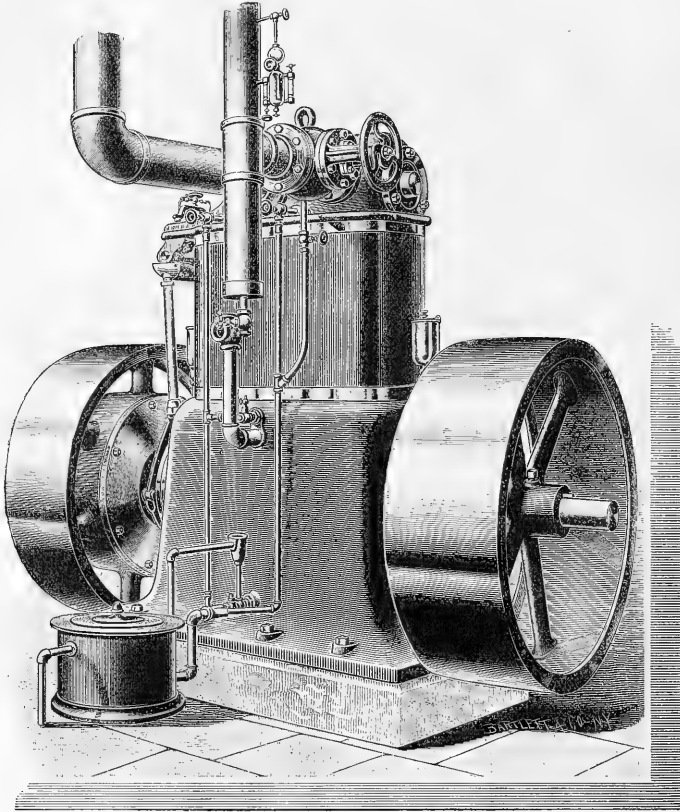

WESTINGHOUSE COMPOUND ENGINE, REAR VIEW.

the compound engine was the laying-out and perfecting of a theoretical diagram on the lines of maximum efficiency, upon which diagram the relative volumes and the valve functions were schemed. This is the reverse of the usual process; but the results, it is claimed, were most conspicuous in their success.

The governing idea in the design is a compound engine in which the functions of admission, cut-off, exhaust, and compression on both the high and low pressure cylinders shall be effected by a single valve, in which intermediate reduction of pressure without corresponding production of useful work shall be obviated, and in which substantially uniform compression to the full initial pressure shall be effected in the high-pressure cylinder, under all variations of load and boiler-pressure, and for all points of cut-off. Such a distribution of steam is theoretically perfect, and has been considered impossible in practice.

its effort, in order to meet each and every variation of load and pressure under which the engine may from moment to moment be operated. Such a capacity, or the attainment of such a result, constitutes the peculiar feature of the single-acting compound engine on which the Westinghouse Company rests its claims of superior economy.

In general form, the compound engine more nearly resembles their Junior engine. The mechanical characteristics of the single-acting engine are retained in every particular. One cylinder is enlarged to practically three and a half times the area of the other. The valve-chest is across the top of the cylinders, being the construction which admits of the least possible clearance in the low-pressure cylinder. The valve-chest is in one piece, the various steam-passages being chambered in it. The valve-seat is in the form of a bush, in which the ports are cut, not cast, to an exact register. This

bushing is reamed out, and forced steam-tight into its bored seat. This form of construction has many advantages. The casting is greatly simplified, avoiding all chances of porosity, sand-holes, and other defects which are liable to cause concealed leaks. The valve-seat can be made perfect, and the parts registered exactly, on which latter fact depends the perfection of the steam-distribution, and the consequent economy of the engine; and, lastly, the valve-seat can be easily and cheaply renewed when worn.

The valve-chest also contains a small by-pass valve controlling a cored passage, by which live steam can be admitted to the low-pressure cylinder, to turn the engine over its centre when starting. The steam and exhaust connections are on the side of the valve-chest towards the back of the engine, bringing the throttle-valve

der out upon a table, and examining it carefully, two adult beetles of *Tenebrioides mauritanica* were found dead in the burrows in the powder. How long these beetles had remained in the powder alive, it is obviously impossible to state; but it would be safe to say that they entered it from motives of choice, and either subsisted upon it, or else did an incredible amount of tunnelling without sustenance. While at the time the beetles were removed from the powder the latter was not fresh, and did not retain its full strength, there still remained enough to impart a tingling, burning sensation to the nostrils when any of the powder was inhaled through the nose, yet not enough to set one to sneezing.

— In Germany, for some years past, according to the *Journal of the Society of Arts*, London, efforts have been made, and with

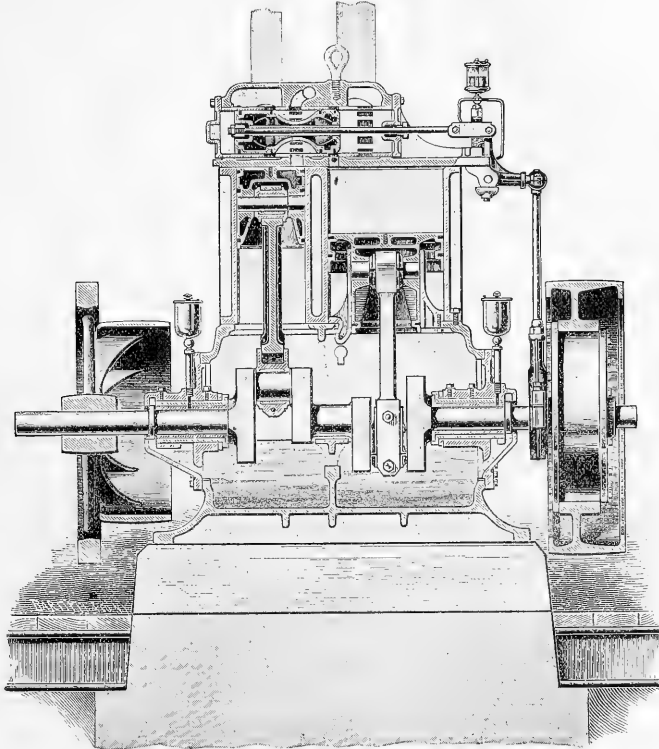

WESTINGHOUSE COMPOUND ENGINE, LONGITUDINAL SECTION.

into convenient position, and admitting of the ready removal of the valve-chest when desired.

NOTES AND NEWS.

F. M. WEBSTER, Purdue University, La Fayette, Ind., in a letter to the United States Entomological Bureau, Dec. 23, 1887, states that some two or three years previous samples of various substances used for insecticides were placed in the Agricultural Museum of Purdue University, at La Fayette, Ind. As the object was merely to display the substances, they were placed in glass flasks, such as are used for similar displays of seeds, the mouth being in the base when the flask is in an upright position. One of these flasks contained several ounces of powdered white hellebore, which, as it was never disturbed, had settled into a somewhat compact body. On removing this flask a few days later, the cork stopper was found to have been burrowed through, evidently from without, and the mass of powder was literally full of burrows and channels passing through it in all directions. On turning the pow-

derable success, to acclimatize the oak silkworms of China and Japan (*Attacus Pernyi* and *Attacus Yama-mai*). They have been raised in the open air, protected from the attacks of birds by nets of gauze or wire, changed from place to place as the oak-leaves are consumed. Late frosts and excessively dry weather have been injurious in depriving the worms of food. In California a new wild silk-moth, before unknown, has been found thriving on the poisonous species of *Rhamnus Californicus* or *R. Purshianus*. It produces a silk as good as that of the domesticated *Bombyx*. Owing to the favorable nature of the climate, without the frosts or rains of China and Japan, great hopes are obtained of propagating this species. In Yucatan a wild moth has also been met with, somewhat allied to the mulberry-worm, which produces silk of a bluish tint; but the gum which envelops it is difficult to remove. Mr. John MacIntyre, a recent traveller in Manchuria, records having met with several new species of silkworm, which he describes in the *Chinese Times*. One wild worm feeds on the *Pinus chinensis*. It forms handsome cocoons, which yield a strong silk; but they are so mixed up with the needle-like leaves of the pine, that the

winding-off of the silk would be difficult. On the walnuts he found another, which forms a reticulated cocoon, like a Chinese lantern. He also met with two other species of mulberry-worms—one very hardy, which could be fed on lettuce or dandelion leaves, and remains stationary; and another which moves easily from branch to branch in search of food. The rearing of *Attacus orizaba* of Mexico is to be attempted in France.

—The United States Entomological Bureau announces that Brood VIII. of the periodical cicada, which is of the seventeen-year race, will appear this year through quite an extent of country. The region commences in south-eastern Massachusetts, extends south across Long Island and along the Atlantic coast of New Jersey, Delaware, and Maryland as far as Chesapeake Bay; then up the Susquehanna River in Pennsylvania to a point a little below Harrisburg; thence westward in Ohio, embracing the south-western corner of the State and the north-western portion of Kentucky; and then upward through south-western Indiana, ending in central Illinois. It is possible, also, that there is an eastward extension of the region from Kentucky into southern West Virginia, as cicadas occurred in 1855 in the Kanawha valley, and also in the counties of Buncombe and McDowell, in North Carolina; but, as these appearances were not verified in 1872, it is probable that they belong to Brood XVIII., which is of the thirteen-year race. The bureau will be glad to receive full accounts this year of all appearances from any of their correspondents, and from all others who will be kind enough to write them of occurrences in their vicinity. Accounts from North Carolina and West Virginia are especially desired, as these will tend to clear up any doubt remaining as to what brood occurred in those States in 1855.

—Professor H. B. Gale, in a paper on a new theory of chimney-draught and the design of brick and iron stacks, read before the St. Louis Engineers' Club, stated that he had made numerous experiments to determine the different factors which entered into the problem, and gave some formulæ in shape for convenient use. He showed, that, while the area of a stack could not be reduced below certain limits, it could be increased without affecting the efficiency of the stack.

—President Frederick Augustus Porter Barnard of Columbia College died April 27, aged eighty years. He was born May 5, 1809, at Sheffield, Berkshire County, Mass.

—A very curious race, possessing no little interest for students of natural history, and which is vouched for by our English contemporary *Knowledge*, was recently witnessed in Westphalia, the contest being between pigeons and a number of bees, the respective owners of which had wagered their favorites to win. The course was three miles and a half, that being the distance between the two villages of Rhyern and Hamme; and a dovecot which happened to be near a hive was selected as the winning-post. It was found no easy matter to mark the bees so as to make their identity unmistakable, but the difficulty was at last surmounted by rolling them in flour previous to starting them on their journey. This, while making them easily recognized on their arrival, probably retarded their flight; but nevertheless, and though the pigeons were looked upon by those interested as the most likely winners, the race resulted in a victory for the bees; the first bee arriving at the post twenty-five seconds before the first pigeon, and three other bees before the second.

—It is generally conceded that for best results in butter-making, where the milk is set in deep cans, the milk should be placed in the creamer as nearly as possible at the temperature at which it is drawn from the cow; there being a considerable loss of fat in skim-milk if the milk is allowed to cool to any great extent before being set. Of late there has been considerable controversy as to whether it is advisable under any conditions to warm the milk before setting, and as to the limit of temperature beyond which it is not safe to go. Mr. I. P. Roberts concludes, as the result of investigations at the College of Agriculture at Cornell University, that, first, there is a loss of butter when the milk is allowed to cool much below the normal heat of the cow before being put into the creamer; second, while there may not be any very great increase of butter when the milk is heated, there is no risk of injuring the quality of the butter

by incorporating an excess of caseine, even when the milk is heated as high as 135°.

—At a meeting of the Massachusetts Classical and High School Teachers' Association, April 5-6, President Eliot suggested an argument against admission to college on teachers' certificates, that has the interest of novelty. A college that admits pupils from a number of schools on certificates puts all such schools on a level, and denies to them the opportunity of special distinction. A principal who knows that his school is superior to certain others cannot publish this fact, and win his due applause, unless his pupils come into competition with the pupils of the other schools in admission examinations. According to *The Academy*, President Eliot cited the instance of a high-school principal in New York, who, disheartened at his inability to show his public that his school was a superior one, gave up teaching and went into business.

—The removal of tattoo-marks is a matter of no little difficulty, says *Nature*, and many different methods have been tried,—blistering, suction, thermo-cautery, counter-tattooing with white powder or milk, etc. Criminals sometimes pour vitriol on their arms or hands, and letting it act for a few seconds, plunge the limb in water. The following method is recommended by M. Variot, in the *Revue Scientifique*: The skin is first covered with a concentrated solution of tannin, and re-tattooed with this in the parts to be cleared. Then an ordinary nitrate of silver crayon is rubbed over these parts, which become black by formation of tannate of silver in the superficial layer of the dermis. Tannin-powder is sprinkled on the surface several times a day for some days to dry it. A dark crust forms, which loses color in three or four days, and in a fortnight or so comes away, leaving a reddish scar free of tattoo marks, and in a few months little noticeable. It is well to do the work in patches about the size of a five-franc piece at a time. The person can then go on with his usual occupation.

—At a public meeting held at Channing Hall in Boston, Dec. 13, 1887, an association was formed for the purpose of assisting the Pundita Ramabai in her plans for the education of child-widows in India. The Pundita's purpose and her plans for the proposed school, told in her own simple manner, were listened to by a large and enthusiastic audience. Addresses were made by Rev. Dr. E. E. Hale, Rev. Dr. Phillips Brooks, Rev. George A. Gordon, and Rev. Dr. F. Courtney. They urged upon all to assist this unselfish woman, who is working for the uplifting of her unfortunate countrywomen. A constitution, embodying the methods of the association, was adopted, and officers were elected. Many present pledged the annual payment of sums varying from one to ten dollars, for ten years. Several scholarships, of one hundred dollars annually for ten years, have been secured, and donations for a building-fund are being received. It is estimated that \$25,000 will be needed for purchasing and furnishing a suitable building to accommodate fifty pupils. The annual payment of \$5,000 will meet the current expenses of the school, and contributions, however small, will be gratefully received. Choice English literature, with other instructive and useful books, for a school library, will be acceptable. In order to raise the funds needed for starting and sustaining the work suggested by Ramabai, her friends have organized in different places "Ramabai Circles," pledging themselves to give annually, for the space of ten years, a certain fixed sum of money. These circles will communicate with, and transmit their contributions to, The Ramabai Association of Boston. The trustees of the Ramabai Association will keep themselves informed of the progress and effectiveness of the work in India, and no steps will be taken or remittances made except subject to their judgment. A careful consideration of the difficulties of the situation in India has led to the conviction that a school-building is indispensable. In addition to the unjustly high rent that would be demanded for a building for a school for women, there may arise, through the prejudice of the Hindus against women's education, many other difficulties. The landlord may, at any time he pleases, ask the school to leave the place; and the disturbance of its daily routine, the inconvenience and loss caused by such moving about, would be incalculable. It is therefore best that it have a building of its own. Even the hire of a building, for such a purpose, must

in ten years cost at least \$10,000: the sum of \$25,000 will provide permanently a handsome building (furniture and all), which will accommodate about fifty persons. The Ramabai Association, with its headquarters in Boston, has the following officers: president, Rev. Edward E. Hale, D.D.; vice-presidents, Rev. Phillips Brooks, D.D., Rev. George A. Gordon, Miss Frances E. Willard, Mrs. Mary Hemenway, Dean Rachel L. Bodley, M.D.; treasurer, Mr. T. Jefferson Coolidge, jun.; advisory board of India, Dr. Ramakrishna G. Bhandarkar, Rao Bahadur M. Ranade, Rao Saheb Deshmukh; corresponding secretary, Miss A. P. Granger, Canandaigua, N.Y. At a meeting held March 14, 1888, The Ramabai Circle of New York was organized, with the following officers: president, Mrs. Courtlandt Palmer; secretary, Miss L. S. Chambers; treasurer, Mr. Richard A. Anthony.

— Hengst's powder, as we learn from the *Engineering and Mining Journal*, is manufactured from straw properly prepared and chemically treated, and finally converted into a gunpowder of granular form. Its special use lies in the direction of military and sporting purposes, although in its compressed form it will probably be found applicable to blasting operations, inasmuch as, weight for weight, it possesses about 150 per cent greater strength than gunpowder, and it appears to be impossible to explode it by concussion. Its action, however, is more rapid and local than that of gunpowder, so that a greatly reduced charge only is required to produce results equal to those produced by that explosive. But, notwithstanding the rapidity of its action, so far as present investigation has gone, it would appear to be peculiarly suitable for the two main purposes which Mr. Hengst had in view when inventing it; namely, military and sporting. In order to test the merits of the powder, a series of trials was recently carried out by Mr. Perry F. Nursey, C.E., at the testing ranges of Messrs. Cogswell & Harrison, at Harrow. The experiments were made comparative with black powder, and in the trials having reference to military use the government pattern Martini-Henry rifle and ammunition were used. The charge in the case of the black powder was 85 grains, as against 35 grains of Hengst's powder, all other details remaining the same. Considering that the latter powder was only produced experimentally and in small quantities, the results were very satisfactory. The velocities, which were taken by chronograph, appear to have been a little lower and a little less uniform than those of the black powder. As regards smokelessness, flamelessness, non-heating, and non-fouling with the Hengst powder, these points appear, says *Iron*, to have been set at rest by Mr. Nursey's experiments. Smoke there was none, says that gentleman's report; only a puff of light vapor (carbonic gas), which rapidly condensed and disappeared from sight. Flame there was none, so far as the eye could detect in a darkened rifle range, only a faint pale-blue glow being visible at each discharge. Fouling there was none, in the ordinary sense of the word, while a number of rounds fired in rapid succession failed to do more than warm the barrel. An equal number of rounds of black powder similarly fired from the same rifle, cold, heated it considerably. As regards the nature of the report, it appears that in every case there was distinctly less noise with the Hengst than with the black powder.

— The work of cutting through the Isthmus of Corinth is reported by *The Builder* to suffer under the same financial difficulties as the Panama Canal work. A German technical journal states that when the subscription was opened for the carrying-out of the scheme in 1882, estimated to cost thirty million francs, and to be finished in six years, the money was subscribed five times over. In 1887, however, this sum had been expended, and a further sum of thirty million francs was invited. However, up to the present, only a third of this sum has been obtained, and, if no further funds can be obtained, the work on the canal will soon have to be stopped. Hitherto about two-thirds of the earthworks have been executed, but there still remains a great deal to be done; and it is now stated, that, as the canal will cost twice as much as originally estimated, no profits can be anticipated.

— At the monthly meeting of the Royal Meteorological Society, on April 17, the following papers were read: "On the Deaths caused by Lightning in England and Wales from 1852 to 1880, as recorded in the Returns of the Registrar-General," by Inspector-

Gen. R. Lawson, LL.D. The total number of deaths from lightning during the twenty-nine years amounted to 546, of which 442 were of males, and 104 of females. In consequence of their greater exposure, the inhabitants of rural districts suffer more from lightning than those of towns. It appears, also, that vicinity to the west and south coasts reduces the chances of injury by lightning, and that distance from the coast and high land seems to increase them. "The Diurnal Range of the Barometer in Great Britain and Ireland," by Mr. F. C. Bayard, F. R. Met. Soc. The author has reduced the hourly records of the barometer at the nine observatories, Aberdeen, Armagh, Bidston, Falmouth, Glasgow, Greenwich, Kew, Stonyhurst, and Valencia, during the years 1876-80. The curves of inland places are smoother than those of places on the seacoast, and the curves of places to the westward are more irregular than those of places to the eastward. As we go from south to north, the general tendency of the curve is to get flatter with a lessened diurnal range. "Note on a Working Model of the Gulf Stream," by Mr. R. W. Clayden, M.A., F. R. Met. Soc. The author showed this interesting model at work. It has been constructed to illustrate the formation of ocean-currents in general, and of the Gulf Stream in particular. "On the Rime Frost of Jan. 6 and 7, 1889," by Mr. C. B. Plowright, F.L.S. The author gives an account of the very heavy rime which occurred in the neighborhood of King's Lynn on these days, when the fringe of crystals upon twigs and branches of trees was about two inches in length. The weight was so great that nearly all the telegraph-wires were snapped, and an immense number of branches of trees broken off.

— We regret to have to record the death of Mr. Warren De la Rue, F.R.S. He was born in 1815, according to *Nature*, and died on Good Friday, after a short illness from pneumonia. Mr. De la Rue was a most devoted observer and munificent patron of astronomy, and in him and Balfour Stewart solar physics has lost its chief founders.

— During the past few years, much attention has been given to the subject of economy in heating greenhouses, and the manufacturers of steam-heating apparatus have made great efforts to supplant the long-established system of hot-water heating. In order to get some facts in regard to this subject, so important to the grower of plants under glass, and gain some positive knowledge as to the relative value of the two systems, two houses were constructed at the Massachusetts Agricultural College, Amherst, Mass., during the summer of 1888, 75 by 18 feet, as nearly alike as possible in every particular. Two boilers of the same pattern and make (F. W. Foster, manufacturer, 51 Charlestown Street, Boston, Mass.) were put in, — one fitted for steam, and one for hot water (the steam, for heating the east house; and hot water, for the west and most exposed one). The boilers were completed and ready for work in November, and were tested until Jan. 9, 1889, when these experiments began. Records of the temperature of each house were made at 7.30 and at 9 A.M., and 3, 6, and 9 P.M. Sufficient coal was weighed out each morning for the day's consumption, and the balance not consumed deducted the next morning. The two boilers and fittings were put in so as to cost the same sum, and were warranted to heat the rooms satisfactorily in the coldest weather. As far as could be determined by close examination and weighing, there was about the same proportion of unconsumed coal as of that consumed in the ashes from each boiler. The hot-water boiler consumed 720 pounds less coal than the steam-boiler in February, and 688 pounds less in January, — a saving of nearly 20 per cent. At the same time the temperature of the room heated by hot water averaged 1.7° higher than that heated by steam. The temperature was more even where heated by hot water, and consequently there was less danger from sudden cold weather. This was strikingly shown on the night of Feb. 22. The average outside temperature for the day was 34°. At 9 P.M. it was above 32°, and, proper precautions not having been taken for so sudden a change as followed, at 6 o'clock on the morning of the 23d the temperature of the room heated by steam was 29°, while in that heated by hot water it was 35°. While this test is conclusive for the two boilers employed in these two houses as constructed, and for this unusual winter, in a larger house, and in a

winter where the temperature runs lower and with greater extremes, different results might possibly be obtained; but this can only be settled by carefully made and accurately recorded tests, which it is hoped may be made another year.

—The death is announced in *Nature* of April 25, of Dr. Paul du Bois-Reymond, professor of mathematics at the Technical High School of Berlin, and formerly at the Universities of Freiburg and Tübingen. He was the author of two well-known mathematical works, and brother of the eminent physiologist of the same name. He was born on Dec. 2, 1831, and died at Freiburg in Baden on April 7.

—A Chinese native paper published recently, says *Nature*, a collection of some zoological myths of that country, a few of which are worth noting. In Shan-si there is a bird which can divest itself of its feathers and become a woman. At Twan-sin-chow dwells the Wan-mu Niao (mother of mosquitoes), a fish-eating bird, from whose mouth issue swarms of mosquitoes when it cries. Yung-chow has its stone-swallow, which flies during wind and rain, and in fine weather turns to stone again. Another bird when killed gives much oil to the hunter, and when the skin is thrown into the water it becomes a living bird again. With regard to animals, few are so useful as the "Jih-kih" ox, found in Kansuh, from which large pieces of flesh are cut for meat, and grow again in a single day. The merman of the Southern Seas can weave a kind of silky fabric which keeps a house cool in summer if hung up in one of the rooms. The tears of this merman are pearls. A large hermit-crab is attended by a little shrimp which lives in the stomach of its master. If the shrimp is successful in its depredations, the crab flourishes, but the latter dies if the shrimp does not return from his daily excursions. The "Ho-lo" is a fish having one head and ten bodies. The myths about snakes are the strangest of all. Thus the square snake of Kwangsi has the power of throwing an inky fluid when attacked, which kills its assailants at once. Another snake can divide itself up into twelve pieces; and each piece, if touched by a man, will instantly generate a head and fangs at each end. The calling-snake asks a traveller, "Where are you from, and whither are you bound?" If he answers, the snake follows him for miles, and, entering the hotel where he is sleeping, raises a fearful stench. The hotel proprietor, however, guards against this by putting a centipede in a box under the pillow; and, when the snake gives forth the evil odor, the centipede is let out, and, flying at the snake, instantly kills him with a bite. The fat of this snake, which grows to a great size, makes oil for lamps, and produces a flame which cannot be blown out. In Burmah and Cochinchina is a snake which has, in the female sex, a face like a pretty girl, with two feet growing under the neck, each with five fingers, exactly like the fingers of a human hand. The male is green in color, and has a long beard: it will kill a tiger, but a fox is more than a match for it.

—Besides the usual attractions for the spring and summer, the excursion committee of the Appalachian Club has arranged for a club camping trip for August. The camp will be on Student Island in Mooselucmagantic Lake, the largest of the Rangeley chain. Capt. Fred C. Barker, who owns and runs the steamers on this lake and leases Student Island, will accommodate the party, engaging a man and his wife to have special charge of the camp and to do the cooking. The party will have the use of a frame cottage, in which a few persons can be accommodated; but, as the excursion is arranged to please people who love camping, it is expected that the majority will sleep in tents. Camp-life, boating, canoeing, bathing, fishing, steamer excursions on the lakes, tramps in the forest, and ascents of Bald and Deer Mountains, will be attractions. It will be possible for members to arrange small parties, engage special guides, and make trips to Parmachenee Lake, Aziscolos Mountain, or other points of interest in the Androscoggin region. The camp will be opened early in August, and continue open till the middle of September if desired.

—The Connecticut Agricultural Experiment Station calls attention of farmers and others to the fact that it has extended its field of investigation by the addition of a new department, for which a laboratory has been completed during the past winter, and equipped with the necessary books and apparatus for the study of

fungi which are injurious to vegetation through the production of rusts, smuts, rots, mildews, blights, and similar diseases. A small greenhouse is attached to the building for winter experiments, which has been used since its completion for preliminary experiments to test the utility of certain methods of treating smut in onions, to which special attention will be given during the coming season. In order to obtain as much information as possible on this subject, questions have been prepared, and sent to numerous onion-growers; and any one who can give any information on the subject should send to Dr. Roland Thaxter, 27 Lincoln Street, New Haven, Conn., for a set of the questions.

—The director of the Hatch Experiment Station of the Massachusetts Agricultural College, Amherst, Mass., invites all who may have valuable or especially interesting new varieties of fruits, vegetables, trees, shrubs, or flowers, to send them to him, that they may be tested side by side, and under the same conditions, with other new and the standard older varieties. The situation of this experiment station is now such that the best of attention will be given to all such new varieties, and careful observation and unprejudiced reports made of their behavior and merits. He would urge that especial attention be given to promising local seedling apples that have not been propagated and disseminated. On almost every farm may be found numerous chance seedlings; and, as most of the standard varieties now in cultivation have originated in this way, all seedlings that have the valuable qualities of size, beauty, flavor, vigor, and freedom from disease, should be further tested.

—Attention is called by *Building* to the advantages of wire-weave waterproof roofing. The Architectural Building Trades Exhibition, just closed in London, offered an opportunity to show its numerous applications. It is intended mainly as a substitute for galvanized iron in building. The roofing sheets are less than half the weight of twenty-four gauge corrugated iron, and, being composed of stout papier-mâché, with fine steel-wire foundations, they are excellent non-conductors of heat and cold. A settler's hut, 14 feet by 10 feet, weighing little over half a ton, was exhibited. It was a strong, and at the same time a picturesque building, with overhanging eaves, snow-white walls, and tiled roof. Many of these huts have been sent to the South African gold-fields, and other places where portability is important.

—Clark University, Worcester, Mass., has issued a preliminary announcement of the work of the university, to begin in October next, in the departments of mathematics, physics, chemistry, biology, and psychology, with such additional facilities for the study of languages as scientific students may require. This preliminary limitation of the wide academic field indicates no bias and no restriction of ulterior plans, but is adopted in the interests of more effective organization. It is intended that these departments shall be gradually organized and sustained on the highest plane possible in existing conditions. No distinctively undergraduate classes will be formed, and no candidate for lower college classes will be received at first. While not declining to confer the degree of A. B., the university will, for the present, give special attention to qualifying for higher degrees. Ten fellowships of the first class of four hundred dollars each, ten fellowships of the second class of two hundred dollars each, and ten scholarships with free tuition, have been provided. The rate of tuition has been fixed at two hundred dollars a year, exclusive of laboratory fees. Applications can now be received, and should be accompanied by a statement of the course of study, and, if possible, by a specimen of work. A prospectus containing fuller announcements will soon be issued.

—At a meeting of the Physiological Society, Berlin, March 27, according to *Nature*, Dr. Klemperer spoke on the proteid needs of the animal economy in health and in certain pathological conditions. Voit's teaching, that the human body in health requires daily from 100 to 120 grams of proteid in order to supply its nitrogenous needs, has been recently contested from many sides; and, even if the experiments on which the attacks were based were not altogether free from some defects, they still sufficed to cast a good deal of doubt on Voit's theory. The speaker had endeavored, working from the clinical point of view, to decide the question whether an increased proteid metabolism can be prevented or

diminished by an increased ingestion of carbohydrates or fats. He carried out experiments on the nutrition of two healthy persons, in which the daily dose of proteids was very considerably diminished, even down to 40 grams; while, in compensation for the lessened proteids, larger quantities of fats, sugar, and easily absorbed and oxidizable alcohol, were administered. The nitrogen excreted in the urine was constantly less in amount than that taken in the food, thus showing that healthy, active men can be fed with largely diminished amounts of proteid without the occurrence of any destructive metabolism of their tissue-proteids. He next proceeded to investigate whether, in diseases which are characterized by an abnormally large breaking-down of tissue-proteids, this increased nitrogenous metabolism could be lessened by the ingestion of an increased quantity of non-nitrogenous food. An increased nitrogenous metabolism occurs in dyspnoea, fever, anæmia, cancer, tuberculosis, diabetes, and Addison's disease. For dyspnoea, experiments were made on animals; while for anæmia, cancer, diabetes, and Addison's disease, observations were made on the human subject, and results were obtained which corresponded to the supposition under which the experiments were started. A very considerable reduction of the nitrogen excreted in the urine was observed when only moderate quantities of proteid were given, while at the same time increased amounts of carbohydrates, fats, and alcohol, were administered. It is impossible to enter here into the interesting details of these experiments, which were all carried out by very precise methods, or into a discussion of the hypotheses which were advanced in explanation of the phenomena which had been observed.

— The following are the dates of some of the international exhibition congresses which are to be held in Paris: technical education, July 8 to 12; bibliography of the exact sciences, July 16 to 26; chemistry, July 29 to Aug. 3; ballooning, July 31 to Aug. 3; pigeons, July 31 to Aug. 3; hygiene, Aug. 4 to 11; higher education, Aug. 5 to 10; physiological psychology, Aug. 5 to 10; geography, Aug. 6 to 11; photography, Aug. 10 to 17; criminal anthropology, Aug. 10 to 17; primary education, Aug. 11 to 19; horticulture, Aug. 16 to 21; prehistoric man and remains, Aug. 19 to 26; electricity, Aug. 24 to 31; chronometry, Sept. 2 to 9; mines and metallurgy, Sept. 2 to 11; applied mechanics, Sept. 16 to 21; meteorology, Sept. 19 to 25; river utilization, Sept. 22 to 27; commerce and industry, Sept. 22 to 28; and hydrology and Climatology, Sept. 30 to Oct. 15.

— M. Berthelot, at a meeting of the Paris Academy of Sciences, April 8, read a paper on the fixation of nitrogen by vegetable soil with or without the aid of leguminous plants. The paper deals with a fresh series of sixty-four methodic experiments carried out during the year 1888, and fully described in the April number of the *Annales de Chimie et de Physique*. They form a sequel to the systematic researches begun by the author in 1883, and tend fully to confirm the views already announced by him on the fixation of free nitrogen in the ground, effected either with or without the cooperation of luzern, vetches, and other leguminous plants. He considers the fixation now fully established, and finds in this fact the true interpretation of a multitude of phenomena highly important to agriculture. At the same meeting, M. J. Reiset described some experiments on putrefaction and the formation of manures. The more recent of these fully confirm the results of those undertaken by the author so far back as 1854, and show, that, in the process of organic decomposition, nitrogen is not fixed, but liberated.

— According to *Nature*, a series of regulations with regard to patents and designs has just been issued in Japan. All inventors whose discoveries are beneficial, or are calculated to improve existing processes of manufacture, may apply for letters patent. No patents, however, will be granted in the case of articles of food or drink, or in case of medicines. Inventors who do not receive letters patent are powerless to sue in respect of piracy of their inventions. In order to register an invention, application must be made to the Patents Bureau, and, if the officials are satisfied as to the genuineness of the invention, it is registered, on certain forms being completed with, and certain fees paid. A curious omission occurs in the regulations, but it is not plain whether it is intentional or not. Nothing whatever is said as to the rights of a foreigner to patent

an invention, but it is presumed that he will not be able to do so, nor has any provision been made for advertising applications for letters patent. The Patents Bureau is to be the sole judge of all cases submitted to it, and from its decision there is no appeal; but in certain cases two judges sit with the bureau, and assist in deciding whether a patent should be granted or not. The duration of a patent is to be five, ten, or fifteen years, according to the amount paid in fees. The patent, of course, passes by assignment *inter vivos*, or to the patentee's heir, but nothing is provided for the cases of bankruptcy or marriage.

— *Nature* states in a recent issue, that, from a report of the Belgian consul-general in the Kongo State, it appears that the efforts made to introduce European vegetables and fruits in that district have been rewarded with very great success. The government has imported tobacco-seed from Havana and Sumatra, which is cultivated in conjunction with native tobacco. The natives cultivate tobacco badly, but efforts are being made by the government to teach them better methods. The inhabitants of the Lower Kongo have been very successful in cultivating not only the usual African products, such as manioc, sweet-potato, etc., but also sorghum, maize, and the "wandu" haricot, called "boma" by the natives. The cotton-plant grows in its wild state, and the natives manufacture from it hats, wallets, etc. No effort has yet been made to cultivate it for trade purposes.

— A carbohydrate of the empirical composition $C_6H_{10}O_6$, and possessing properties very closely resembling those of the arabin of "gum-arabic," has been artificially prepared by Professor Ballo of Buda-Pesth. This achievement, we learn from *Nature*, is the outcome of an attempt to reproduce the conditions under which the acids of the vegetable world are reduced by chlorophyll. It was assumed that the iron of chlorophyll is present in the ferrous state, and tartaric was the acid upon which operations were commenced. About equal quantities of tartaric acid and ferrous sulphate were dissolved in a minimum bulk of water, and the solution was warmed upon a water-bath. In a short time a grayish-yellow precipitate began to separate. The whole was then evaporated until it completely solidified on cooling. The cold mass was next extracted with alcohol, and the extract again evaporated. The residue thus left by volatilization of the alcohol was neutralized with milk of lime, and the filtered solution again placed on the water-bath. It was now noticed, that, as the water was gradually expelled, the contents of the evaporating-dish became more and more viscid, until finally a sticky mass was left, reminding one most forcibly of gum-arabic. Knowing that this familiar article of commerce chiefly consisted of the calcium and potassium compounds of arabin, the likeness was felt to be somewhat indicative of the formation of an arabin-like substance. On allowing the concentrated sirup to cool, a calcium salt readily crystallized out, yielding, on analysis, numbers pointing to the formula $(C_6H_{10}O_6)_2Ca + 9H_2O$. From this the free carbohydrate was obtained in one of two ways, — either by precipitation of the solution in water with lead acetate and subsequent decomposition of the lead salt with sulphuretted hydrogen, or by addition of the calculated quantity of oxalic acid. The sirup of "iso-arabin," as it is provisionally termed, was further purified by repeated treatment with alcohol and ether, and subsequent re-evaporation. It was then allowed to stand over sulphuric acid, — some specimens for a month, and others so long as a whole year. Each of these specimens, on combustion, yielded numbers indicating the empirical formula $C_6H_{10}O_6$. Iso-arabin is an almost colorless sirup, readily mixing with water. It does not reduce Fehling's solution, but rotates the plane of polarization to the right. It behaves, in short, exactly like the carbohydrates of the $(C_6H_{10}O_6)_n$ group. The potassium salt obtained by decomposing the calcium salt with potassium carbonate also crystallizes well in large anhydrous crystals. In addition to iso-arabin itself, a small quantity of its hydrate $(C_6H_{10}O_6 + H_2O)$ is also formed by the action of ferrous sulphate upon tartaric acid, and separates out in crystals from the alcoholic washings of the crude iso-arabin. Natural arabin itself forms a similar hydrate; the precipitate formed by addition of hydrochloric acid and alcohol to a solution of gum-arabic, when dried at $100^\circ C.$, possessing this composition.

SCIENCE:

A WEEKLY NEWSPAPER OF ALL THE ARTS AND SCIENCES.

PUBLISHED BY

N. D. C. HODGES,

47 LAFAYETTE PLACE, NEW YORK.

SUBSCRIPTIONS.—United States and Canada.....\$3.50 a year.
Great Britain and Europe.....4.50 a year.

Science Club-rates for the United States and Canada (in one remittance):

1	subscription	1 year	\$	3.50
2	"	1 year	6	00
3	"	1 year	8	00
4	"	1 year	10	00

Communications will be welcomed from any quarter. Rejected manuscripts will be returned to the authors only when the requisite amount of postage accompanies the manuscript. Whatever is intended for insertion must be authenticated by the name and address of the writer; not necessarily for publication, but as a guaranty of good faith. We do not hold ourselves responsible for any view or opinions expressed in the communications of our correspondents.

VOL. XIII. NEW YORK, MAY 10, 1889. No. 327.

CONTENTS:

THE WESTERN ELECTRIC INCANDESCENT LIGHTING SYSTEM.....	357	HEALTH MATTERS.	
THE WESTINGHOUSE COMPOUND ENGINE.....	355	Ventilation.....	356
NOTES AND NEWS.....	357	Cholera Treatment.....	357
EDITORIAL.....	362	Yellow-Fever in Florida.....	357
The Spread of Measles.....		Insomnia.....	357
THE AMERICAN DIALECT SOCIETY.....	362	Tobacco-Smoking.....	367
THE BOWER-BARFF RUSTLESS IRON PROCESSES.....	363	Action of Electric Light on the Eyes.....	367
ETHNOLOGY.		BOOK-REVIEWS.	
Notes from British Columbia.....	364	Physiological Notes on Primary Education and the Study of Language.....	367
Deformation of Heads in British Columbia.....	365	AMONG THE PUBLISHERS.....	367
ELECTRICAL NEWS.		LETTERS TO THE EDITOR.	
A New Alternating-Current Electro-Motor.....	365	A New Mountain of the Bell	
Relation between Density of Acid and Capacity in Secondary Batteries.....	366	<i>H. Carrington Bolton</i>	368
A New Arc-Lamp.....	366	Rainfall and Latent Heat	
Quartz as an Insulator.....	366	<i>H. A. Haasen</i>	369
		Alphabetic Law and World-English	
		<i>A. Melville Bell</i>	369
		Ayrton and Perry's Scotchmeter	
		<i>J. G. MacGregor</i>	369
		Clintonite, or Seybertite?	
		<i>Albert H. Chester</i>	370

THE FOLLOWING INSTANCE is reported to have occurred in Glasgow, and shows how easily measles may be spread. During the month of January, forty-two persons belonging to the congregation of a Gaelic church were taken ill with measles. Taking twelve to fourteen days as the recognized period of incubation, Dr. Russell, the health-officer, connects two serious groups of cases with the attendance at the church of two girls on Dec. 30 and Jan. 13 respectively. One of these girls, it is ascertained, had come from an infected house, while the other had actually taken the disease two days before. Two other girls who usually worshipped elsewhere, but were in this particular church on the 13th, became ill on the 26th, and other circumstances pointing in the same direction are noted. Dr. Russell considers, that, unless something like perfect isolation and disinfection can be guaranteed to a person who is suffering from infectious disease in a house, all healthy members of the household should be debarred from attendance at school, church, or other place of concourse.

THE AMERICAN DIALECT SOCIETY.

IN substance, the plan of this society is to collect and publish dialect material through an executive committee, with assistants in various places. The district secretaries will doubtless, after some experience, become more and more acquainted with the conditions and needs of their respective districts, and will thus be able to ad-

vised the executive committee with more confidence. The members of the executive committee will naturally assist in the direction of active members in their own States. Further, Professor Gustaf Karsten, Bloomington, Ind., will act as secretary for Indiana; Professor E. L. Walter, Ann Arbor, Mich., for Michigan; Professor Alcée Fortier, Tulane University, New Orleans, for Louisiana; Dr. James W. Bright, Johns Hopkins University, Baltimore, for Maryland; Mr. W. D. Armes, University of California, Berkeley, Cal., for California.

The conditions of membership have been made very easy in order to attract many members, for it is believed that the number of those who can contribute material in large or small amounts is very great. All who feel an interest in the plan of the society are invited to join it, even if they do not feel sure of contributing anything but a membership fee. Without a large membership, the expense of printing will render publication only possible in small quantities or at long intervals. With a large membership, it will be possible to publish oftener, and to send the publications to every member without additional charge.

At the annual meetings it is not intended to have papers read. They are to be strictly business meetings, the work of publication being done through the executive committee and the editing committee. No regular issues can yet be announced, but it is hoped that it will be possible later to publish at stated intervals.

Some of the dialect variations indicated below are doubtless survivals of dialects spoken in England; others may be due to the influence of other European languages spoken in the United States and Canada, as French, German, Dutch, Spanish; while still others are probably independent developments in America. All are worth noting, and will have an attraction for linguistic students, perhaps all the greater when they appear to show the beginnings of dialectal divergence. The materials thus collected are not only interesting in themselves: they may be utilized in many ways, as in the construction of dialect maps to show how far each peculiarity extends, in comparisons with dialects in England and on the continent of Europe, in the preparation of a complete list of Americanisms, in assisting the work of lexicographers, and otherwise contributing to the history of the English language in America.

In order to give somewhat more in detail the purposes of the society, and the method of work planned by it, the dialect variations considered may be divided into two classes:—

I. VOCABULARY.—Strange, uncommon, or antiquated words, or uses of words, really current in any community. Such are *deedies* ("young fowls"), *gall* ("assurance, effrontery"), *to play hookey* or *to hook off* ("to play truant"), *to stump* or *to banter* ("to challenge"), *let the old cat die* (used of letting a swing come to rest gradually instead of stopping it), *slew* ("a great quantity"), *fool* (as an adjective), *he up and did it*, *he took and hit him*, *he's been and gone and done it*, *clim* or *clum* (*clomb*), *housen* (as plural of *house*), *the nagent* (for "the agent"), *sandy Pete* (for "centipede"), *to cut* or *to cut and run*, *to leg it*, *to buzz* a person (to talk with him), *buckle* ("to bend," used of ice under one's weight); likewise local names of fishes and plants, exclamations, and words used in games; also lack of common words or phrases which one would expect to find everywhere. It is the natural unstudied speech of different localities that is of interest. Many school-teachers might contribute lists of words and phrases which they perhaps have to teach their pupils not to use. Any person of education, especially if living in a different place from that where his childhood was passed, may also be able to make contributions. Even one such peculiarity found in common use where it has not already been noted has a value for the purposes of the society. Many such words and phrases have already been published in the collections of Americanisms, but much yet remains to be done in noting unrecorded usages, and in defining limits of use geographically and otherwise.

II. PRONUNCIATION.—For example, the different pronunciations of *r* in words like *hard*, *turn*, *cord*, *mother*; of *a* in *paré*, *calm*, *past*; of *oo* and *u* in *room*, *rude*, *put*; of *o* in *stone*, *hot*; such forms as *git*, *ketch*, *shet* for *skut*, *sech* or *sich*, *he keen* or *kin* for *can*, *deestrich*, *holt* for *hold* (noun), *snack* for *snake*, *hahmer* for *hammer*, etc. It is often possible to tell by a person's pronuncia-

tion from what part of the country he comes. For the study of pronunciation the received spelling is very ill adapted, and a phonetic system is needed if this part of the work is to be conducted in an intelligible manner. In the cases mentioned under 1., where the pronunciation is of only secondary importance, such a system is not needed. It is necessary only where the pronunciation is the main thing to be noted, though it will be welcome whenever the pronunciation might be doubtful. A practical, though necessarily imperfect, system of phonetic spelling will be sent to any person who communicates with the secretary.

The officers of the society are, president, Francis J. Child, Cambridge, Mass.; vice-president, James M. Hart, Cincinnati, O.; secretary, Edward S. Sheldon, 27 Hurlbut Street, Cambridge, Mass.; treasurer, Charles H. Grandgent, Cambridge, Mass.; editing committee, the secretary *ex officio*, George L. Kittredge (Cambridge, Mass.), Sylvester Primer (Charleston, S.C.); executive committee, the officers named above, and Benjamin I. Wheeler (Ithaca, N.Y.), Charles F. Smith (Nashville, Tenn.), Frederic D. Allen (Cambridge, Mass.).

THE BOWER-BARFF RUSTLESS IRON PROCESSES.

THESE processes have for their object the protection of iron and steel from rusting. This result is obtained by the conversion of the surface of the metal into magnetic oxide of iron. The oxide is well known in its natural state as magnetic iron ore, which has withstood without deterioration or change centuries of exposure to the atmosphere and to fresh and salt water.

The Barff process consists essentially in subjecting to the action of superheated steam the articles which are to be rendered rust-proof. The treatment is carried out in a specially constructed furnace, and is more particularly applicable to wrought iron and highly finished and polished work.

The Bower process accomplishes the formation of magnetic oxide upon iron articles by subjecting them successively to the actions of highly heated air and carbonic-oxide gas derived from coal fires. The hot air converts the metallic surface into red oxide of iron, which is reduced to the black or magnetic oxide by the gas.

No foreign material, such as paint, alloy, or chemical of any kind, is applied to the metal; so that the coating is perfectly innocuous, and, owing to the simplicity of the process, its cost is less than that of galvanizing.

Surfaces of iron and steel treated by the Bower-Barff processes present a pleasing blue-gray or blue-black color, and preserve the sharp outline of artistic designs, while, if the articles are polished before treatment, the result of the oxidation is a lustrous, ebony-black finish.

The Bower-Barff processes have now a record of over four years in the United States, so that it is no longer necessary to refer to European practice for evidences of their value. In furnace construction, and other particulars, marked improvements have been made. Furnaces have already been established in the States of Pennsylvania, New Jersey, New York, Connecticut, Massachusetts, and Illinois, and others will shortly be erected.

The oxide process is applicable to all forms of cast, malleable, and wrought iron and steel, where the surfaces are not subjected to very severe friction, nor injured by subsequent manipulation. It is gradually supplanting the expensive and usually unsatisfactory galvanizing, and for ordinary culinary utensils is taking the place of tinning and enamelling. Where, for the sake of appearance, enamel is preferred, English manufacturers have adopted the process, because it is found that by first oxidizing the articles the enamel is rendered far more durable.

The demand by users of cast and wrought iron pipe for plumbing, drainage, gas, salt-works, steam-heating, and wherever it is desirable to protect pipes from rusting, is one of the most significant indications of the recognition of the value of the process.

The following brief review of the processes, in their leading features and recent developments, may serve to show how readily they can be adapted through a very extended range of iron manufactures.

The conversion of the surface of metallic iron into magnetic oxide of iron is carried out in a furnace. The articles to be treated,

whether large or small, are loaded upon an iron drag, and shoved into a fire-brick chamber, known as the oxidizing-chamber of the furnace. Gas-producers, which constitute a part of the furnace structure, generate carbonic-oxide gas from a thick bed of coal upon the producer-grates. This gas is burned by an admixture of air in a combustion-flue beneath the oxidizing-chamber; and either the burning gases, or the hot products of combustion, according as the gas and air valves are regulated, enter through ports into the chamber, heating the charge, and then passing through exit ports to the chimney. After the goods have been raised by this means to the desired temperature, which may vary from an incipient red to a cherry heat, depending on the nature of the work, the treatment of the charge is begun. If the goods consist of castings, the Bower process of alternating oxidizing and reducing operations is generally employed. During the period of oxidation, the connection with the gas-producers is almost entirely cut off by a damper; and air, raised to a high temperature by passing through the hot combustion-flue above mentioned, enters the chamber and oxidizes the iron, converting its surface into the red oxide of iron (Fe_2O_3). After about forty minutes of this treatment, the admission of air to the furnace is stopped, and the producer-gases are allowed to pass for twenty minutes through the chamber without any admixture whatever. The chemical action of these gases upon the ironware results in a change or reduction of the superficial coating of red oxide of iron into the black or magnetic oxide (FeO_4). The operations are repeated a number of times, so that the whole treatment lasts from ten to twenty hours, according to the thickness of the coating to be produced. At the end of the treatment the charge is withdrawn, and the furnace is then ready for treating another lot of ware.

The Barff process for wrought iron is carried out in the same furnace designed for the Bower treatment. The articles are charged and heated in the same manner as above; and, when the proper temperature is reached, highly superheated steam is introduced into the oxidizing-chamber, where a slight plenum, not exceeding one to two inches of water-pressure, is maintained for a period of ten to twenty hours. The steam from a half-inch pipe more than suffices for all the requirements. The superheating is easily effected by a continuous coil-pipe superheater, or by a couple of small intermittent superheating chambers, each filled with a loose checker-work of fire-brick, and forming part of the furnace structure.

The Bower or air process is the more economical one for the treatment of ordinary cast iron; whereas, for wrought and malleable iron, the Barff or steam process has been found more advantageous. Where wrought and cast iron work are combined, the Barff process is applicable. The steam treatment of the cast iron in such a case merely necessitates a longer period of exposure in the furnace than would suffice for producing the desired coating by the air process.

The mechanical finish of the iron, be this either wrought or cast, determines to a large extent the mode of treatment. Rough articles, from which the skin has not been removed, require for the formation of a proper coating in a given time higher heat and more energetic oxidation than goods whose surfaces are more or less finished. A high heat on a finished surface tends to blister and detach the magnetic oxide as it is formed. When articles, therefore, present some finished surfaces, and others which are rough, a comparatively low heat is used in the oxidizing-chamber, thereby precluding the possibility of injuring the surface; while the treatment is continued for a sufficient length of time to insure a thorough oxidation of the rough parts, even at the reduced temperature.

For the steam treatment of highly polished articles, a small muffle furnace is employed. The charge is heated by a flame which plays externally around the muffle. The increased expenditure of fuel thus incurred in heating the articles is more than compensated, in a furnace of small size, by the ease with which even a slight overheating of any portion of the polished goods is prevented.

The magnetic oxide coating is very hard, but comparatively inelastic. It withstands the wear due to friction, but is injured by blows of the hammer and rough usage. Wherever from this cause

the coating is chipped, the iron rusts, though the rust remains localized: it very rarely spreads or raises the coating, as is the common case with paint or electro-deposits.

The protection of the iron being due to a superficial layer of magnetic oxide, and not to any thing penetrating the metal (which would weaken it), it follows that any manipulation that would injure or destroy the continuity of the surface of the iron must necessarily prove destructive of the coating. In riveting, for example, the coating in the immediate neighborhood of the rivet-holes suffers; similarly, in driving nails through sheet-iron roofing, the oxide is chipped at the holes; in fitting "rustless" gas and steam pipe, it is injured by the bite of the wrench and vise, unless these are furnished with lead or copper cheeks; in shearing, it scales along the edge of the metal; and in flanging or bending sheet-iron, the coating on the line of the bend is cracked. The limit of elasticity of the oxide is practically the same as that of the iron: it adheres firmly to the metal under tensile and compressive strains until this limit has been reached, and no further.

A piece of "rustless" iron can be heated on a kitchen range and then plunged into cold water without the least scaling or other change; while coverings of paint, tin, galvanizing, and enamel suffer very much under such action. For this reason, "rustless" hollow ware is more readily cleaned than even enamel

Should a child be born with curly hair, a strabismic eye, or distorted limbs, he is accepted as a healer of coming generations, and all his early training is carefully conducted with a view to increasing his supernatural powers, and control over the spirits of the air. His food is carefully selected, and many articles of every-day use among the common herd are carefully excluded from his bill of fare. He is put in training for a doctor from his infancy, and great things are expected of him when fully developed and endowed with his degree.

"The doctor seldom washes his person, and never cuts his hair, which grows long and bushy in masses, knotted from want of combing, and entangled with burrs and general rubbish, such as floats around an Indian encampment. He adorns his scanty raiment with eagle's down, and altogether presents a weird, not to say untidy appearance.

"In cases of serious illness among members of the tribe, the eastern medicine-man will administer sparingly some pulverized herbs and teas in considerable draughts; but the Haida doctor of the Queen Charlotte Islands scorns all sublunary aids, powders or lotions. When an Indian is very sick, the doctor proceeds slowly at first to agitate his attendant spirit, which is called 'Yek' (in the Tlingit language), and, by extraordinary contortions and severe gymnastic exercises, succeeds, in the course of half an hour, in



FIG. 1.—ORTHOGONAL VIEWS OF INFANTILE SKULL FROM COWICHAN, B.C.

ware. The latter must be allowed to cool after use; and the remains of food in it become dried and congealed, and stick to the utensil, necessitating considerable scraping, and involving danger of injuring the enamel.

Magnetic oxide withstands the action of many brines, alkalies, sulphuretted gases, and weak, organic acids, but it is gradually dissolved by sulphuric and hydrochloric and other powerful acids. The corroding action of these acids, however, is considerably retarded on "rustless" iron, and hence such iron has been successfully used in chemical works where it was exposed to strong acid fumes. Coated articles have been exposed for years, without the slightest deterioration, to sea-water and to the most varied atmospheric conditions.

ETHNOLOGY.

Notes from British Columbia.

IN 1879 Mr. Wardman, an intelligent reporter, accompanied the United States revenue cruiser "Rush" on her trip to Alaska, and described his experiences in a number of interesting letters to the *Pittsburgh Dispatch*. Some of his observations are well worth being rescued from the obscurity of a local paper.

He gives an interesting description of the Haida medicine-man: "The Indian doctor of the coast is an awfully mysterious personage. His first steps in the art of healing, according to the traditions of his tribe, are taken at an extremely early day in his career.

working himself up into a perfect paroxysm of clairvoyancy, throwing off his garments as he progresses, till finally he stands arrayed in a Lydia Thompson skirt about his loins, but is otherwise clothed in foam and perspiration. Then he is ready for business.

"He then makes 'passes' toward the body of the patient, inhaling powerfully through his teeth. Having sucked the disease out of the form of the sick man, the doctor proceeds to the centre of the house, and blows it out up the opening where smoke from the fire finds its exit. Of course, the patient is now in a fair way to recovery. But, in case the patient does not evince any signs of improvement, the doctor finds that the 'conditions are not favorable' owing to the influence of some witch who has evoked an evil spirit to operate against the recovery. In such a case it becomes the doctor's first duty to point out the witch, who is stripped, bound, and subjected to a perfectly puritanical course of torture, with a view of forcing a confession. The rack, the scourge, and starvation finally have the desired effect, and the witch acknowledges any thing that the doctor demands. This is always gratifying, and is considered one of the greatest triumphs of the healing art; but, should the confession be made too late to effect the desired cure, the witch may be killed, and generally is sacrificed on general principles. Even though the patient dies under these circumstances, it is still a triumph for the doctor, as killing the witch is as good a proof of witchcraft in Alaska to-day as it was in New England two hundred years ago.

"The Haida, as well as other Indians of the north-west coast,

own slaves, and have owned them since the memory of man runneth not to the contrary. The original stock of slaves generally consisted of children captured in warfare, whose posterity remain in a condition of bondage. Slaves have been sold by these more northern tribes to the Indians of Puget Sound; and the power over such chattels has been so complete that they have been killed out of compliment to or regard for a dying master, and the women have been leased out for even worse purposes. When a chief dies, it is supposed he will need servants in the felicitous fishing-fields, and that the best way to secure them is to take them with him.

"The records of the Hudson Bay Company at Post Simpson show that in 1842, on one occasion, the agent visited a dying man of some note, and entered the place where he lay just in time to find him engaged in an attempt to strangle his nephew. The agent rescued the boy, and took him into the post, where he was kept till after the departure of the spirit of his kingly uncle. Then the mother of the lad demanded compensation of the company for the annoyance and inconvenience to which her departed brother would be put in the other world by reason of not having the attendance of the spirit of her son, murdered, upon his ghostly majesty. The company paid for that interference in a strictly family affair."

The writer also witnessed a cremation, which he describes as follows: "We were hardly at anchor yesterday [at Sitka] before we were informed that a body was to be cremated. The funeral pyre consisted of a crib of dried logs, about six inches in diameter and six feet in length, arranged four on the ground and three upon each side, supported by green stakes.

"The arrangements were very simple. The body of a woman who had died three days previous was hoisted out of the smoke-hole in the centre of the house. Dead bodies are never permitted to go out through the doorway among these Indians. The body was wrapped in a common bark mat, such as these Indians make, and laid in the crib, the top and ends being closed with logs laid crosswise. The fire was then started; and the mourners, who consisted of female relatives, sat around upon the ground to the windward, and slightly to the right of the burning pile. Their hair had been cut short, their faces were all blackened, and, as the tears from their weeping eyes cut channels through the lamp-black, the effect was rather ludicrous, if grief can be ludicrous under any circumstances. The women, who numbered fifteen or twenty, sobbed, sniffled, and whined with every evidence of genuine grief. This is mentioned because it is the custom here for Indians to hire professional mourners who officiate at the 'wake,'—an important affair among the natives.

"To the left of the women, a number of male relatives of the deceased put in the time chanting continually, and keeping time with staffs about five feet long, which they raised and dropped upon pieces of board so as to produce a rapping noise. The men stood erect all this time, and were led by an old man who held a crowd-frog totem in one hand, which, being shaken, produced a rattling noise, owing to pebbles being within the hollow instrument.

"The ceremony continued for about three hours and a half, when the remains were consumed, with the exception of some of the larger leg and arm bones and a portion of the skull. As soon as the residuum was cool enough to be taken up, the mass, along with some wood-ashes, was placed in a box, which was deposited in a small sort of hencoop on stakes, scores of which dot the hill behind the village. After the cremation, the tired Indians turned in and slept during the afternoon, and at night had their customary dance in honor of the successful issue of the enterprise."

DEFORMATION OF HEADS IN BRITISH COLUMBIA.—It is well known that many tribes of the north-west coast of America are in the habit of deforming the heads of their children. It is an interesting fact that the "fashion" of deformation is distinct in various localities. Thus it becomes possible to distinguish natives from different parts of the country readily by the artificially acquired shape of their heads. In British Columbia three methods of head-deformation are in use. The tribes inhabiting the north point of Vancouver Island compress their heads, particularly those of female children, by means of bandages, the head thus acquiring an extremely long, almost conical shape, the vertex being pushed far back. Farther south the head is compressed between cushions of

cedar-bark. The remarkable form resulting from this procedure is shown in Fig. 1. The marked depression behind the coronal suture indicates the place where a bandage passes over the head. In many instances the heads of adults, by this procedure, attain an enormous width, being wider than they are long. The third shape of head results from the application of a strong pressure on the forehead and occiput, which are compressed between boards. Fig. 2 shows the head of a male adult. It will be seen that the forehead and occiput are perfectly flat. The second method fre-

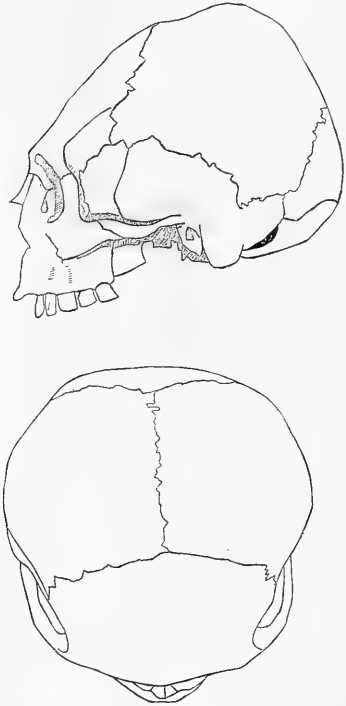

FIG. 2.—ORTHOGONAL VIEWS OF SKULL OF AN ADULT MALE, COWICHAN, B.C.

quently results in extremely asymmetric forms, the parietal bones bulging out very strongly. It is a noteworthy fact that in the majority of cases the left side of the head is more prominent than the right side. Presumably this is due to the fact that the child mostly lies on his right side when in the cradle. In Fig. 1, a well-developed Wormian bone is seen. These are of frequent occurrence in the deformed crania, while the true *Os Inca* is observed not rarely. Anomalies of persistence or premature synostosis of suture are characteristic of these crania. The frontal suture is often persistent, while in a few instances the sagittal suture was found closed at an early age.

ELECTRICAL NEWS.

A New Alternating-Current Electro-Motor.

PROBABLY the two things most needed in the field of electrical engineering are a good storage-battery and a successful alternating-current electro-motor. A year ago, Mr. Tesla described an alternating-current motor before the Institute of Electrical Engineers,—a motor which it was promised would overcome all the defects and

difficulties which had seemed inherent to that type of apparatus. The Tesla motor is now controlled by the Westinghouse Electric Company, and that powerful organization has been exerting all of its energies to make the machine a success, but apparently to no great effect.

There comes from Europe, however, the account of a new motor, which, if we are to believe the figures given, accomplishes all that the Tesla motor promised; and while the latter required a special distributing system, using at least three wires to bring current to the motor, the new machine can be used in connection with the ordinary alternating system employed for incandescent lighting, and only two wires are necessary for the connections.

Messrs. Ganz & Co. of Buda-Pesth have been engaged for four years in experiments on various forms and types of alternating-current motors. Their most recent production gives results such that they feel confident that the performance of continuous-current motors will be attained. The machine in question gave, at 730 revolutions, 30.7 horse-power, or 22,700 watts of work, while the apparent energy consumed was 29,800 watts, and the real energy 27,700 watts, thus giving an efficiency of 80.9 per cent. The ratio between the real and apparent energy consumed was .92, or nearly unity, and this is a very important point. Ordinarily the ratio is less than one-half, the difference of phase between the current and electro-motive force being considerable; so that a great deal of current flows through the motor, which does little more than heat it, the machine running first as a motor, then as a dynamo, the difference between the work done on and by it being small, while the current might have a considerable value. The figures given above were obtained from a model, which was not constructed to give the greatest possible efficiency or output, but which was designed for purposes of study. When properly made machines are turned out, the efficiency should not be less, according to the designers, than 90 per cent.

It is a pity that no description of the machine, nor more accurate experimental data, is available. One can hardly see why such very meagre results should be sent out by the makers. If any thing is given, it should be enough to enable people to judge for themselves the merits of the invention; but the firm of Ganz & Co. is one of great respectability, and there seems to be now some hope that a successful alternating-current motor has been discovered.

RELATION BETWEEN DENSITY OF ACID AND CAPACITY IN SECONDARY BATTERIES. — M. Heim, at the Electro-technical Institute at Hanover, has experimented on the capacity of storage-cells with different strengths of acid. Two types of cells were used, — the Tudor and the Julien. These had a normal capacity of about 50 ampère hours; and, for a first experiment, acid of a strength of from 15 to 20 per cent was used, and the cells were charged and discharged three times, there being an interval of a day allowed between the charge and discharge. The next step was to fill the cells with acid of a strength of, say, 9 or 10 per cent, and again determine the capacity, there being always a number of discharges for each strength of acid, the discharge always lasting until the electro-motive force had fallen 10 per cent from its original value. The results obtained are, that the capacity increases rapidly with an increase of from 10 to 14 per cent in the strength of the acid; that it reaches a maximum at a strength of 16 per cent; then decreases slowly at first, and afterwards rapidly, as the density of the solution increases. M. Heim also made experiments to find out the strength of solution at which the support-plate begins to be attacked. He found that strengths even as low as 20 to 25 per cent were too concentrated, and, as the result of his work, recommends a density of 16 per cent (1.108). This is not so high as that ordinarily employed, the usual density varying from 1.150 to 1.200.

A NEW ARC-LAMP. — A new type of arc-lamp has been introduced into England from France by the Planet Electrical Engineering Company. The upper carbon is fed by means of an electric motor which drives a worm and a train of gearing. The field-magnets of the motor are in series with the arc, the armature being connected as a shunt to the field-magnets. The difference of potential at the two brushes of the motor is two volts. When the lamp is burning steadily, the motor is at rest; but, when the resistance of the arc increases, a solenoid core pulls down a lever,

making contact with the armature, which immediately commences to revolve. Should the arc be made too short, the solenoid reverses the connections, and the armature revolves in the opposite direction. The advantage of the arrangement is, that there is plenty of power to overcome the friction of the slide, and that, with the exception of the solenoid, there are no fine adjustments.

QUARTZ AS AN INSULATOR. — At a recent meeting of the London Physical Society, Mr. C. V. Boys read a paper on the above subject, which is not without some practical interest. It will be remembered that Mr. Boys some time ago succeeded in obtaining extremely fine and strong fibres of quartz by shooting an arrow to which was attached a piece of quartz softened by heat. These fibres may be used instead of silk for delicate suspensions in electrical instruments. In making these fibres, Mr. Boys observed that if they were very fine, and broke between the bow and the target, the extremities assumed the form of a screw about half an inch in diameter and eight or ten inches long. If any body were brought near this screw, the end of it would shoot out toward it, retreating again when the body was removed. It hardly seemed possible to account for this in any other manner than by supposing the fibre to be electrified. If this were the case, it would show that quartz was an exceptionally good insulator, since ordinarily the exceedingly minute charge on the extremely slender fibre would be dissipated almost as soon as it was formed. Carrying his experiments further, Mr. Boys found, that while, even under any circumstances, quartz is a better insulator than glass, under ordinary atmospheric conditions there is no comparison between them. To show these insulating properties, a gold-leaf electroscope was made, the leaves being suspended by a quartz hook. In order to make the conditions as unfavorable as possible, a dish of water was placed in the case. After five hours, the deflection of the charged leaves had only decreased about a quarter. If glass had been substituted for the quartz, the leaves would have been completely discharged in considerably less than a minute. As quartz can be easily softened, and can be readily worked when soft, it should be of great value for electrostatic instruments, where there is always great trouble from leakage. Mr. Boys stated that even when quartz was dipped in ammonia, or boiled in potash, it only required washing to completely restore its insulating properties, and, even when it is raised to a red heat, these properties are recovered on cooling. Some quartz which was kept in fused potash for a considerable time lost its insulating properties to some extent; but, even after this treatment, it was better than glass.

HEALTH MATTERS.

VENTILATION. — The *Sanitary News* gives the following advice in reference to the admission of air to rooms: "Air should be introduced and removed at those parts of the room where it would not cause a sensible draught. Air flowing against the body at, or even somewhat above, the temperature of the air of the room, will cause an inconvenient draught, from the fact, that, as it removes the moisture of the body, it causes evaporation or a sensation of cold. Air should never, as a rule, be introduced at or close to the floor-level. The opening would be liable to be fouled with sweepings and dirt. The air, unless very much above the temperature of the air of the room, would produce a sensation of cold to the feet. It may be regarded as an axiom in ventilating and warming, that the feet should be kept warm and the head cool. The orifices at which air is admitted should be above the level of the heads of the persons occupying the room. The current of inflowing air should be directed toward the ceiling, and should either be as much subdivided as possible by means of numerous orifices, or be admitted through conical openings with the smaller opening toward the outer air and the larger openings toward the room, by which means the air of the entering current is very rapidly dispersed. Air admitted near the ceiling very soon ceases to exist as a distinct current, and will be found at a very short distance from the inlet to have mingled with the general mass of the air, and to have attained the temperature of the room, partly owing to the longer mass of air in the room with which the inflowing current mingles, partly to the action of gravity in cases where the inflowing air is colder than the air in the room."

CHOLERA TREATMENT.—Dr. Yvert, who claims to have had a large experience in the treatment of Asiatic cholera, reports that by the use of bichloride of mercury he has been able to reduce the mortality from 66 to 20 per cent. He also says, that, used as a prophylactic in those who have recently arrived in a region infected with cholera, it has in every instance warded off the disease.

YELLOW-FEVER IN FLORIDA.—From the best information we have been able to obtain, the reported case of yellow-fever at Sanford, Fla., was a true case. The patient, a Mrs. Dumont, wife of a boarding-house keeper, died April 20.

INSOMNIA.—Insomnia is an affection which is trying to both physician and patient alike, and many are the remedies which have been recommended for its cure. The latest of these is the peanut, eaten *ad libitum* just before retiring. A member of the clergy reports success with the peanut after having tried other means without result.

TOBACCO-SMOKING.—We have recently given the views of different physicians as to the effects of tobacco-smoking upon health, and have also referred to experiments bearing upon the question of the antiseptic power of tobacco-fumes. Additional evidence on these points is constantly accumulating. Dr. Hajek of Vienna has declared that smokers are less liable to diphtheria than non-smokers in the ratio of 1 to 2.8; and Dr. Schiff says that smoking is forbidden in the bacteriological laboratories, because it is known to hinder the development of bacteria in the various culture-media.

ACTION OF ELECTRIC LIGHT ON THE EYES.—A new disease, called photo-electric ophthalmia, is described as due to the continual action of the electric light on the eyes. The patient is awakened in the night by severe pain around the eye, accompanied with excessive secretion of tears. An oculist of Cronstadt is said to have had thirty patients thus affected under his care in the last ten years.

BOOK-REVIEWS.

Physiological Notes on Primary Education and the Study of Language. By MARY PUTNAM JACOBI, M.D. New York and London, Putnam. 12°. \$1.

"If literature were the business of life, or if, as was at one time supposed, education meant nothing else but acquaintance with literature, there would be some logic in the extraordinary prominence habitually assigned in education to the study of modes of expression. But from the modern standpoint, that education means such an unfolding of the faculties as shall put the mind into the widest and most effective relation with the entire world of things, spiritual and material, there is an exquisite absurdity in the time-honored method." Such is the opinion of the author; and such, we are glad to say, is the growing opinion of all observant men and women, except, perhaps, those whose observation is limited by the walls of their classrooms, and who do not discern the signs of the times. Dr. Jacobi gives us, in this book of but one hundred and twenty pages, the account of a most interesting personal experiment in primary education, in which a child was taught algebraic signs as a means of concisely expressing certain relations, long before any attempt was made to learn how to write. It would be interesting, did space permit, to follow in detail this experiment. By the time the child was four and a half years old, she had learned the following elements: straight, curved, slanting, and half-slanting lines; also to distinguish perpendicular and horizontal lines, and to draw either straight or curved lines parallel to each other. She was well acquainted with all forms of the triangle, the rectangle, square, trapezium, trapezoid, pentagon, hexagon, circle, and cube. When five years, the child was taught the equality of any two subjects which were demonstrably equal to the same third. And so the child went on to arithmetic, the meaning of words, and botany, before she was six years old.

The author discusses quite fully the place for the study of language in a curriculum of education. On this subject Dr. Jacobi says that it is necessary to maintain a just proportion between the

study of languages and the other studies of a general curriculum. The effect on mental development and training is to be obtained, if at all, by the age of fourteen, fifteen, or sixteen. By this time the pupil requires the broader and more robust discipline of other knowledge, pursued with the thoroughness of scientific method which will then be practicable. It is undesirable to continue the systematic study of languages at this time (they should be dropped altogether); although the habit of reading in all may be most profitably kept up, and other subjects, especially history, studied through their medium. We must confess a great deal of surprise at some of the results which Dr. Jacobi reached in her experiment with the child already referred to. Had this child's accomplishments been reported to us in ordinary conversation, we should have regarded her as a phenomenon. But it is evident that her teacher believes that what was done with her could be done with the average child; and we have too much confidence in Dr. Jacobi to deny it without due consideration, yet would like to see the experiment carried out on a large scale before deciding that the plan was a feasible one. Having given no little attention to the study of languages, and knowing some of their difficulties, we are astonished to find the author stating that "one great reason for teaching children a reading acquaintance with four or five languages between the ages of eight and fourteen, is, that by the latter age they may really know these languages, and then begin to study something else, or of more immediate practical utility," as if a child could at the age of fourteen have a reading acquaintance with four or five languages, and really know them. We should be glad to learn that the opportunity had been given Dr. Jacobi to carry out her plan on a sufficiently extended scale to determine its practicability, for the results which she claims are certainly much to be desired.

AMONG THE PUBLISHERS.

GINN & Co. have just issued "A Vocabulary to the First Six Books of Homer's Iliad," by Professor Thomas D. Seymour of Yale College. It is claimed that a concise special vocabulary to the Homeric poems, or to parts of them, is open to far fewer objections than a similar vocabulary to any other work of Greek literature, since the words are found more nearly in their original significations and constructions. This vocabulary has not been compiled from other dictionaries, but has been made from the poem itself. The maker has endeavored to be concise,—to give nothing but what is important for the accurate and appreciative reading of the Iliad,—and yet to show the original and derived meanings of the words, and to suggest translations which should be both simple and dignified. A confident hope is felt that the concise form of this vocabulary will save much time for the beginner in Homer. More than twenty woodcuts, most of which are new in this country, illustrate the antiquities of the Iliad.

—*The Index of Current Events* (Montreal) was originally intended as a weekly for the use of editors only, and the amount of the annual subscription was decided upon with due regard to the comparatively limited possibilities in the way of circulation among the class it was intended to serve. It has since been suggested that an index of this character might have a much wider utility, and that in particular all those whose calling it is in any way to educate and mould public opinion would find such a publication of considerable service. *The Index of Current Events* is therefore offered at one dollar per annum, post free.

—T. Y. Crowell & Co. will publish soon George Brandes' "Impressions of Russia," in which are included chapters on Russian literature, which has been translated by Samuel C. Eastman of Concord, N.H., who spent last summer in Denmark, and worked under Brandes' supervision.

—Houghton, Mifflin, & Co. have nearly ready a collection of poems by Dr. S. Weir Mitchell, the eminent Philadelphia physician, entitled "The Cup of Youth," which will be published in shape similar to his former volume, "A New Year's Masque;" and a volume by Mrs. A. J. Woodman, a niece of the poet Whittier, entitled "Picturesque Alaska," giving an amusing account of experiences on a trip to Alaska, illustrated with photographs of the most

striking scenes at various points of the journey. Mr. Whittier has written an introduction to the volume.

— Ginn & Co. announce, in the Library of Anglo-Saxon Poetry, Vol. VI. "Cynewulf's Elene," edited by Charles W. Kent, M.A. The introduction of this work will contain an account of the manuscript, author, sources, theme of poem, etc., as well as a discussion of the versification, particularly of rhyme. The text is accompanied by the Latin original at the foot of each page. The notes, intended as aids to the student, will be full, and frequent reference will be made to Cook's Sievers' "Grammar."

— Mr. E. I. Brill of Leyden, Holland, announces the publication of J. Büttikofer's work on "Liberia," founded on investigations made in 1879-82 and 1886-87. At the present time, when the suppression of African slave-trade attracts so much attention, a study of the Republic of Liberia will be very welcome to many readers, and Americans will be particularly interested in it on account of the enormous amount of labor and money devoted by our countrymen to the establishment and development of this republic. The author, who has devoted much of his time to studies on the natural history and ethnology of this country, gives a description of his journey, and sketches of life in the republic, as well as among the little-known aboriginal tribes. The illustrations are taken from photographs and sketches made by the author.

— Little, Brown, & Co. have now ready a volume entitled "The United States," by Professor J. D. Whitney. The volume is made up from the article written for the "Encyclopædia Britannica," modified in such a manner that it appears as originally written, with the facts and figures illustrating the physical geography of our country and its material resources, corrected down to the beginning of the present year. They have also just issued the index volume to the "Encyclopædia Britannica," completing the work.

— "Bell Hangers' Hand-Book," by F. B. Badt, is just the book for those engaged in selling, installing, or handling electric batteries, electric bells, elevator, house, or hotel annunciators, burglar or fire alarms, electric gas-lighting apparatus, electric heat-regulating apparatus, etc. It is said to be the only book of the kind, and is published by the Western Electric Company, Chicago.

— E. & F. N. Spon will issue shortly, "Sewerage and Land Drainage," by George E. Waring, jun., and announce as in press "A Theoretical and Practical Treatise on the Strength of Beams and Columns," in which the ultimate and the elastic limit strength of beams and columns is computed from the ultimate and elastic limit compressive and tensile strength of the materials, by means of formulas deduced from the correct and new theory of the transverse strength of materials, by R. H. Cousins. This firm further announces a "Treatise on Water-Supply, Drainage, and Sanitary Appliances of Residences: including Lifting Machinery, Lighting and Cooking Apparatus, etc.," by Frederick Colyer; and "The Voltaic Accumulator; an Elementary Treatise," by Emile Reynier, translated from the French by J. A. Berly, C.E.

LETTERS TO THE EDITOR.

*.*Correspondents are requested to be as brief as possible. The writer's name is in all cases required as proof of good faith.

The editor will be glad to publish any queries consonant with the character of the journal.

Twenty copies of the number containing his communication will be furnished free to any correspondent on request.

A New Mountain of the Bell.

I HAVE just returned from a journey of four weeks in the Desert of Mount Sinai, made with the especial object of studying the Jebel Nagous in connection with the joint researches of Dr. Alexis A. Julien and myself on musical sand. The "Mountain of the Bell" is situated on the Gulf of Suez, about four hours and a half from Tor by the roundabout camel-route. It was first described by Setzein in 1808, since which time it has been visited by Ehrenberg, Gray, Wellstedt, Rüppell, Ward, Newbold, and the late Professor Palmer, as well as by large numbers of pilgrims. My observations confirm in the main their accounts of the acoustic phenomena heard, but my measurements differ widely from those of all the travellers save Professor Palmer.

The name "Jebel Nagous" is given by the Bedouins to a

mountain, nearly three miles long and about 1,200 feet high, composed of white sandstone bearing quartz pebbles and veins. On the western and northern sides are several large banks of blown sand inclined at high angles. The sand on one of these slopes at the north-west end of the mountain has the property of yielding a deep resonance when it slides down the incline either from the force of the wind or by the action of man. This bank of sand I distinguished from the others by calling it the "Bell Slope." It is triangular in shape, and measures 260 feet across the base, 5 to 8 feet across the top, and is 391 feet long (high). It has the high inclination of 31° quite uniformly. It is bounded by vertical cliffs of sandstone, and is broken towards the base by projecting rocks of the same material. The sand is yellowish white, very fine, and possesses at this inclination a curious mobility, which causes it to flow, when disturbed, like molasses or soft pitch, the depression formed being filled in from above and advancing upward at the same time. The sand has none of the characteristics of sonorous sand found on beaches. When pulled downwards by the hands, or pushed with the feet, a strong vibration is felt, and a low note is plainly heard resembling the deep bass of an organ-pipe. The loudness and continuity of the note are related to the mass of sand moved, but I think that those who compare it to distant thunder exaggerate. The bordering rocky walls give a marked echo, which may have the effect of magnifying and prolonging the sounds, but which, as I afterwards ascertained, is not essential. There are no cavities for the sand to fall into, as erroneously reported. The peak of Jebel Nagous rises above the Bell Slope to the height of 955 feet above the sea-level, as determined by a sensitive aneroid.

After studying the locality and phenomenon for several days, I formed the opinion that it could not be unique, as hitherto supposed, and accordingly I tested every steep slope of blown sand met with on the caravan-route northward to Suez. On April 6 I examined a steep sand-bank on a hillock only 45 feet high, and was rewarded by the discovery of a second Nagous. This new Nagous is in the Wadi Werdan, only five minutes off the regular caravan-route, and one and a half days by camels from Suez. The hillock is called by the Bedouins "Ramadan," and forms the eastern end of a range of low hills about one-quarter of a mile long. Being the only hills in the Wadi, the locality can easily be found by travellers. The hills consist of conglomerate and sandstone, and towards the west of gypsum. They slope up gradually from the north, and end in bold cliffs on the south side. Sand blown by the north wind is carried over the cliffs, and rests on the steep face at two inclinations, — 31° above, and 21° or less below. By applying the usual tests with the hands to the fine-grained sand, I found, that, wherever it lies at the requisite angle to produce mobility (31°), it yielded the bass note, though not so loud as on the Bell Slope of Jebel Nagous. In one instance my friend and fellow-traveller, Henry A. Sim, Esq., of the Madras Civil Service, who kindly aided me in my investigations, heard the sound while standing 100 feet distant. The Nagous sand occurs at intervals throughout the quarter-mile of low cliffs; the main bank at the east end being 150 feet wide and 60 feet high, measured on the incline. I stirred up the sand pretty thoroughly on this slope, and the next day it failed to give the sounds, not having recovered its properties. The intervening night was very cold (53°).

I feel confident that this phenomenon is not very rare in the desert, though the spontaneous production of sounds by sliding of the sand without man's agency, as at Jebel Nagous, may be. Whether the Rig-i-Rawan north of Cabul is caused by similar conditions remains to be determined, but I am informed that the peculiar relations existing between England and Russia will prevent my visiting northern Afghanistan at present.

The Bedouins who accompanied us were greatly astounded at my discovery of a new Nagous, and I fear that their faith in a monastery hidden in the bowels of Jebel Nagous has received a severe shock.

It is interesting to note that the Nagous, or wooden gong, is in daily use in the monastery of St. Catherine, Mount Sinai. I photographed Jebel Nagous and vicinity, as well as my new Nagous, and collected specimens of the rocks, sand, etc. This is merely a preliminary notice, fuller details being reserved for the work on musical sand in preparation by Dr. Julien and myself. I shall be

obliged if those having opportunities of examining banks of dry and fine sand, inclined at 31° , in the arid regions of the West, will report through your columns whether they yield deep sounds when disturbed.

H. CARRINGTON BOLTON.

Cairo, Egypt, April 10.

Rainfall and Latent Heat.

It is probable that no element engaged in the increase of energy in storm-formation, according to ordinary theories, exceeds in importance that of heat set free in the condensation of vapor. Professor Espy was one of the first to enunciate this principle, and to insist upon its entire adequacy to account for all the phenomena even in the most violent tornadoes. Professor Ferrel has said, "Even if any part of the atmosphere should receive such an [primitive] impulse as to produce a most violent hurricane, friction would soon destroy all motion, and bring the atmosphere to rest. Hurricanes, then, and all ordinary storms, must begin and gradually increase in violence by the action of some constantly acting force. . . . This force may be furnished by the condensation of vapor ascending in the upward current in the middle of the hurricane, in accordance with Professor Espy's theory of storms and rains. According to this theory, all storms are produced by an ascending current of warmer atmosphere saturated with moisture, and this current is kept in motion by the continual rarefaction of the atmosphere above by means of the caloric given out of the vapor which is condensed as it ascends to colder regions above."

Professor Mohr gives this calculation of the effect of latent heat set free on Oct. 5, 6, and 7, 1844: "The Cuban hurricane has used for the moving of the air which was rushing in during those three days at least 473,500,000 horse-power; that is, at least fifteen times as much as all wind-mills, water-wheels, steam-engines, locomotives, man and animal power, on the whole earth produce in that time. Whence comes this immense power? From the latent heat of the vapors which rise in the middle of the hurricane, and are condensed during this process. A rainfall of one millimetre (.04 of an inch) per day on a circular surface eight geographical miles in radius would be sufficient to produce, by the liberating of the latent heat in the vapor, the force which the Cuban hurricane displayed in the air-cylinder mentioned above."

These examples will serve to show the views held by two of the most prominent writers on this subject. I have examined the writings of more than twelve scientists, and find that all, without exception, emphasize the importance of this effect. Diligent search has been made in all quarters for a quantitative determination of this effect, but without success. It has seemed of some importance to make a beginning at such analysis, even though, as will readily be seen, the subject is an exceedingly difficult one to elucidate. The following proposition is presented:—

There can be no considerable condensation from saturated air as long as latent heat is set free from it. A short computation will show that the condensation of a grain of water will set free enough latent heat to raise a cubic foot of saturated air about seven degrees in temperature. Let us imagine it to be possible to condense one-seventh of a grain of moisture out of a cubic foot of saturated air at 80° without changing its temperature: latent heat would immediately be set free, and would just re-*evaporate* the moisture. It would seem at first sight as though this would always be the result, and hence that no precipitation could ever occur without the intervention of some other force. At all events, the proposition above seems abundantly proved.

Suppose, however, that we try to abstract enough heat to lower the temperature one degree. We shall find, that after abstracting enough heat to lower the temperature one-third of a degree, and to condense .111 of a grain of moisture, the rest will be needed to balance the latent heat evolved by the condensation. We shall then have our air saturated at 79.7° , and a precipitation of .111 of a grain. It might be thought that this process could continue indefinitely, but this is not the fact. If we inquire how the above cooling has been possible, we find at once that it has been brought about by heating the surrounding air. I think we can best see this by imagining two cubic feet of air at 80° , side by side and yet distinct. Suppose that, instead of raising the surrounding air, all the heat abstracted in cooling the first cubic foot be passed into the second.

We shall then have one cubic foot of saturated air at 79.7° , and another of unsaturated at over 80° . If, now, we mix these, we shall have two cubic feet of unsaturated air at over 80° , and this will need quite a cooling before any further precipitation.

Of course, in nature no such sudden transitions as these occur, but the principle seems to be the same in all cases. The results following such a process are far-reaching and most important, but there is no space here for dilating further upon the question. It seems to me, after a most careful study of the problem, that we have virtually, in an ascending current, an analogous effect to that in mixing two bodies of air at different temperatures. In the latter case it is admitted by all meteorologists that no considerable precipitation can ever occur. If this computation be true, we have a most important deduction, and have apparently wiped out at a single stroke one of the main-stays of theoretical meteorology as now taught. I confess to great diffidence in advancing this computation; but if it shall result in the development of the true principles involved, and a quantitative determination of the effects in many other theories now on an exceedingly unsubstantial basis, I shall be only too glad to be proved in error.

H. A. HAZEN.

Washington, D.C., April 29.

"Alphabetic Law" and "World-English."

MR. MATTHEW MONROE CAMPBELL, a retired teacher, resident in Boulder, Col., has issued a series of open letters, advocating the official establishment of "Alphabetic Law" in the writing of English, under the direction of a government bureau. "Alphabetic Law," Mr. Campbell says, "requires (1) a single sign or letter for each sound; (2) a single sound for each sign or letter; (3) a joint name for each sign and its sound (its own sound must be the name for a letter); (4) to ortho-graph, or right-write a spoken word, is simply to change each sound in the word for a letter named after it; (5) to ortho-ep, or right-voice a written word, is simply to change each seen letter back to its unseen sound; a letter, then, cannot have two values, and a letter can never be silent, for a letter is a seen sound."

The idea of enforcing such principles, however excellent, in government printing, or by the authority of a State department, is not likely to meet with favor. The "Alphabetic Laws" are certainly good, so far as they go; and I would point out that they are strictly carried out in the scheme of "World-English." In the latter case, however, they are not proposed for adoption in common orthography, but merely for facilitating the acquirement and the world-wide diffusion of our language. Any thing like a proper and complete phoneticism of ordinary literature is not to be looked for in our day.

ALEX. MELVILLE BELL.

Washington, D.C., May 7.

Ayrton and Perry's Secohmmeter.

SCIENCE of April 26 contains a description of Ayrton and Perry's secohmmeter, an instrument consisting of two commutators fixed on the same axle. In your article it is stated that an electrolytic cell will not polarize with rapidly alternating currents, and that consequently the secohmmeter may be employed to measure the resistance of electrolytes in a manner described. May I call your attention to a paper of mine, published in 1882 in the "Transactions of the Royal Society of Canada" (Sec. III. p. 21), in which this method of determining the resistance of electrolytes was, I think, first described? My experience in developing it showed that the electrodes of an electrolytic cell do become polarized, even with very rapidly alternating currents, and that consequently the method which is sketched in your article cannot be trusted to give accurate results. I found, however, that the double commutator, employed in the manner specified in your article, was useful as keeping the polarization at a very small value, and I was able to eliminate the error due to it in the measurement of resistance by introducing two electrolytic cells of the same section, but of different lengths, into two adjacent arms of the Wheatstone's bridge, an adjustable resistance being included also in the arm containing the smaller cell, and by making the other arms consist of wires of equal resistance.

J. G. MACGREGOR.

Dalhousie College, Halifax, N.S., April 30.

Clintonite, or Seybertite?

THE first discovery of the mineral called by these names was in 1828, by Mr. J. Finch, Professor W. W. Mather, and Dr. William Horton, at Amity, Orange County, N. Y. It was named "clintonite" on the spot by the discoverers. Dr. Beck soon after examined it sufficiently to enable him to decide it to be a distinct species; but he made no publication of the fact at the time, though it was distributed to collectors under this name.

In the *American Journal of Science* (vol. xvi. 1829) it was described by Mr. Finch under the name of "bronzite," which he then thought it was; and, although no analysis is given, the description is complete in every other respect, and thoroughly identifies the mineral in question.

In the same journal (vol. xix. 1831, p. 169), in a report of the "Proceedings of the New York Lyceum of Natural History," the following sentence occurs: "Dr. Torrey presented bronzite (clintonite) from Orange County." There can be no doubt as to what mineral is meant.

Clemson, in the *Annales des Mines* (3d series, vol. ii. 1832), describes the same mineral, giving the first analysis, under the name "seybertite," after the well-known chemist, Henry Seybert. It was also called "chrysophan" by Breithaupt in the same year, and "holmsite" by Thomson in 1836.

In Beck's "Mineralogy of New York" (1842) there is a statement of the facts in the case, a claim of priority being made as follows: "The name 'clintonite' was given to it by the discoverers

in honor of DeWitt Clinton; and, as all subsequent examinations have proved their opinion that it was a distinct species to have been correct, it seems to be proper that the name should be retained. It has been generally adopted by the German mineralogists, and those of New York certainly will not hesitate to follow the example." This conclusion was accepted, and the name generally adopted. Dana, who uses "seybertite" in 1837, changes to "clintonite" in his 1844 edition, and retains the name in those of 1850 and 1854. In the fifth edition (1868), after the name had held its place for more than twenty-five years, Dana goes back to "seybertite," because, as he says (p. 508), "Clemson's name 'seybertite' . . . has therefore priority of publication, and must be accepted as the name of the species." In this he has been followed by most writers since, and "clintonite" has been placed in the list of synonyms.

But the fact is that "clintonite" was the name first given and first published; for the publication in 1831, quoted above, is earlier than that of any other name except "bronzite," which of course cannot stand, and indeed was not meant as a new name. Further, this name was in general use among dealers and collectors before Clemson's name appeared at all. It therefore seems right, and a matter of simple justice, to adopt the name "clintonite," under which indeed the mineral is best known, as the name of the species, thus honoring "our distinguished statesman, scholar, and man of science, DeWitt Clinton." ALBERT H. CHESTER.

Hamilton College, Clinton, N. Y., April 29.

INDUSTRIAL NOTES.

The Thomson-Houston System in Boston.

THOSE in whose mind there still clings some doubt as to the reliability of the electric railway will find in the following report of the Cambridge Division of the West End Street Railway, Boston, figures, furnished by the Thomson-Houston Company, that prove conclusively that the electric railway can be depended upon. This road has a previous record of but 9 trips lost out of 1,179. The following report is for the month of April: average number of motors in daily service, 8; round trips of motor-cars, 2,720; time in service, motor-cars, 3,232 hours; mileage of motor-cars, 17,680 miles; round trips, one tow-car, 2,720; round trips, two tow-cars, 226; time in service, towed cars, 3,500 hours 30 minutes; mileage of towed cars, 19,149 miles; total car round trips, 5,666; total car mileage, 36,829 miles. Of the above round trips, but 7 were lost. In addition to the new contracts mentioned in the last issue, the Thomson-Houston Company has just contracted with the Naumkeag Street Railway Company of Salem, Mass., to supply them with 6 motor-trucks, each equipped with two 15-horse-power motors. They will be used on the line from Salem to the Willows. The company has also received an order from the East Harrisburg Passenger Railway for one double-motor truck, equipped with two 15-horse-power motors. Work is rapidly progressing on all the roads which the company has under contract, and very soon some of them will be put in operation. Work on the new line of the Revere Street Railway is being rapidly pushed toward completion. The piles are all driven, the cross-timbers put on, and the track is nearly all in place. The line is double-track, and will extend from Winthrop Junction to Crescent Beach, and may be continued beyond there on the tracks of the West End Street Railway Company of Boston.

Electric Railway at Atlantic City, N. J.

During the last week the Sprague Electric Railway at Atlantic City was started, and the operation of the road on the trial trip of the cars was perfectly successful; and the cars ran over the entire distance of the road at a speed exceeding fifteen miles an hour, towing another car behind them. A number of the officials of the road were present, and expressed great satisfaction at the operation of the cars, their ease at starting and in rounding the curves. The equipment of this road includes the new 15-horse-power motors of the Sprague Company, and all the latest devices and improvements in use by the Sprague Company upon their street-railways. This system of roads at Atlantic City, which is now being completely equipped with electricity, is controlled by the

Pennsylvania Railroad Company. Before adopting any system upon this road, the officials of the railway company made a thorough investigation of all the systems of electric propulsion, both cable and electric, in use in all the cities of this country, and during the investigation, which lasted about five months, visited nearly all the cities in which there were electric railways in use. They were so thoroughly satisfied by this investigation that electricity is the most convenient and economical as well as reliable force for operating the street-cars, that they have given orders to cover the entire equipment at this place. It is estimated that the roads will carry very large numbers of passengers during the coming season.

More Street-Railways.

The coming of summer is heralded by the large number of street-railways which have decided to adopt electricity upon their roads. During the centennial week that has just passed, a number of railway companies have signed contracts for complete electrical equipments; and it is interesting to note that among these is one of the largest and most important street-railways in the important city of St. Louis, Mo. We understand from the Sprague Company that they have closed a contract during the past week with the Lindell Avenue Street Railway Company of St. Louis, Mo. This contract calls for 10 cars of 30 horse-power each, to be operated over 5 miles of track. The overhead system will be used, and the line covers some of the most noted and principal streets of that city. The contract of this company with the Sprague Company calls for a complete equipment, including dynamos and full station equipment. Another of these contracts is with the Wilkesbarre and Westside Railroad of Wilkesbarre, Penn. It will be remembered that the Wilkesbarre and Suburban Railway was one of the first to equip with electricity; and, since this road has been put in operation, its success has been so great that its management have ordered an additional number of cars. The installation of this second line in the same town with the other lines is a most gratifying indication of the success which electric railways have gained. This line will extend over 4 miles of track, and the equipment will include 3 complete Sprague cars, and all the latest attachments in use upon many of the Sprague roads. The Bay City Street Railway Company has also contracted for electrical apparatus during the past week, and this equipment calls for 3 cars and 5 miles of track. Before deciding upon any system, the Bay City (Mich.) Railway Company made an investigation of electric railways now in use, and visited a large number of cities in which there are electric railways in operation. As a result of this investigation, the contract was awarded to the Sprague Company.

GUARANTY INVESTMENT COMPANY

CAPITAL \$250,000.

Offices: Atchison, Kan. 191 Broadway, New York. 222 Walnut St., Phila.

Hon. ALBERT H. HORTON (Chief Justice, Kansas Supreme Court), Topeka, Kan., Pres't.

7% Guaranteed Farm Mortgages 7%

The Guarantee Investment Company makes loans upon fertile farms in the choicest portions of Kansas and Nebraska and has adopted the policy of sending a Committee of its Investors each year to examine its loans and methods of business.

The Committee this year consisted of PROF. A. H. BERLIN, Principal of the High School Montrose, Pa., and MAJ. THEODORE L. POOLE, Ex-U. S. Pension Agent, Syracuse, N. Y. Both of these gentlemen are persons of the highest character and have the confidence of the Communities in which they reside.

The Committee has recently returned and has made a very interesting Report upon the general development of Kansas and Nebraska as well as the business of the Company. The Company will be glad to send this Report to any address.

The following names are taken from the long list of Investors in our Mortgages:

(See if Some Friend of Yours is not in the List.)

William A. Caldwell, 59 Liberty St., N.Y.
 Palmer Cox, 658 Broadway, N.Y.
 Rev. H. H. Ryland, D.D., 12 Livingston Place, N.Y.
 Rev. Brady E. Backus, D.D., 360 West 28th St., N.Y.
 Rev. R. M. Sommerville, 126 West 45th St., N.Y.
 Dr. Robert A. Murray, 235 West 23d St., N.Y.
 Dr. James F. Tuttle, 136 West 41st St., N.Y.
 H. Edwards Rowland, 218 Fulton St., N.Y.
 Irving H. Tift, Esq., 271 Broadway, N.Y.
 Prof. D. G. Eaton, 55 Pineapple St., Brooklyn, N.Y.
 Dr. F. P. Thwing, 136 St. Marks Ave., Brooklyn, N.Y.
 Dr. C. G. Wiles, Greenport, N.Y.
 John V. N. Bergen, Fort Jefferson, N.Y.
 Benj. W. Stilwell, Yonkers, N.Y.

R. C. Coleman, Goshen, N.Y.
 Mrs. Samuel Carlisle, Newburg, N.Y.
 Dr. C. C. Bartholomew, Ogdensburg, N.Y.
 Rev. Nelson Millard, D.D., Rochester, N.Y.
 Rev. Horace G. Hinsdale, D.D., Princeton, N.J.
 Dr. Charles M. Howe, Passaic, N.J.
 George A. Skinner, 5 Railroad Place, Newark, N.J.
 Dr. Edwin M. Howe, 85 Halsey St., Newark, N.J.
 Dr. H. G. Buckingham, Clayton, N.J.
 Dr. Martin Cole, Jr., Hainesville, N.J.
 Mortgage Trust Co. of Pa., Philadelphia, Pa.
 Miss Mary Miller, 1230 Spruce St., Philadelphia, Pa.
 Henry D. Biddle, 313½ Walnut St., Philadelphia, Pa.

Dr. Calvin C. Halsey, Montrose, Pa.
 Rev. William Baldwin, Great Bend, Pa.
 Gen. William Lilly, Mauch Chunk, Pa.
 Second Nat. Bank, Mauch Chunk, Pa.
 Enos E. Thatcher, West Chester, Pa.
 Mrs. Townsend Poore, Scranton, Pa.
 Rev. Burdett Hart, D.D., New Haven, Conn.
 Dr. Frank H. Wheeler, New Haven, Conn.
 Charles R. Christy, Stamford, Conn.
 Mrs. Catharine P. Fuller, Woodmont, Conn.
 Miss Jessie Henderson, Lenox, Mass.
 Dr. M. J. Halloran, Worcester, Mass.
 Albert Walker, Bennington, Vt.

Address for Report and Monthly Bulletin

HENRY A. RILEY, General Eastern Manager, 191 Broadway, N.Y.

ONE LANGUAGE FOR THE WHOLE WORLD.

WORLD-ENGLISH :

THE UNIVERSAL LANGUAGE. 25 CENTS.

EVERY one has heard of the butcher who, after a long search for his knife, at last found it in his mouth : so speakers of English have been seeking for a universal language, when, lo ! it is in their mouths. The intelligibility of English words has been obscured by a dense mist of letters. This is now dispersed by A. Melville Bell, who has already won a world-wide reputation through his invention of "Visible Speech," the great boon to deaf-mutes. Professor Bell calls this new discovery of his "World-English," and the result is a language which cannot fail to meet with acceptance, and at once supersedes the supposed necessity for "Volapük," or any other artificial language. No language could be invented for international use that would surpass English in grammatical simplicity, and in general fitness to become the tongue of the world. It is already the mother-tongue of increasing millions in both hemispheres, and some knowledge of the language is demanded by all educated populations on the globe. Social and commercial necessities require that the acquisition of this knowledge shall be facilitated, and it is believed that Professor Bell's invention has removed the last impediment to English becoming the universal language, for which vague desires have long been entertained, although hitherto only futile efforts have been made.

Ex-President Andrew D. White, of Cornell University, says : "I believe that the highest interests of Christian civilization and of humanity would be served by its adoption. China and Japan would be made English-speaking peoples within fifty years, and so brought within the range of Christianizing and civilizing ideas, in the largest sense. All existing missionary work is trivial as compared with this. For your system would throw wide open those vast countries, as, indeed, all the countries of the world, to the whole current of English and American thought."

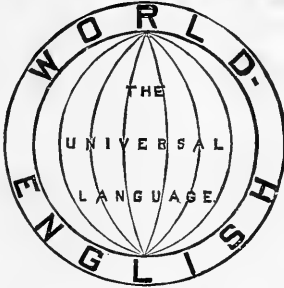

For Diffusion of English throughout the World

AS THE UNIVERSAL LANGUAGE

This "Hand-Book of World-English" is the Complete, Simple, and Efficient Medium.

FOREIGNERS

Will Acquire, by Means of this Hand-Book, a PERFECT PRONUNCIATION OF ENGLISH.

For Primary School Pupils and Illiterate Adults

World-English is a Royal Road to Reading.

To Teachers of English and Modern Languages

This Hand-Book will be of Primary Importance as a Phonetic Directory.

DEFECTS OF SPEECH

Will be Readily Corrected by Means of the Articulative Directions in this Hand-Book.

HAND-BOOK OF WORLD-ENGLISH,

25 CENTS.

The plan of this little book is altogether new. Letters and sounds are so associated, in all the exercises, that from the mere knowledge of letters a learner cannot fail to pronounce words with certainty. English reading will thus be easily acquired, whether by natives or foreigners, children or adults.

The general resemblance of World-English to Literary English is such that any reader of the latter decipheres the former at sight, or, at most, after a few minutes' study of the new letters. A like result may be anticipated for those who shall learn to read from World-English. They will transfer their power of reading to the literary form of the language, almost without effort. The orthographic aspect of words will, besides, be so fixed in the eye, by contrast, that spelling will be remembered as — what it really is — a pictorial association with words.

No special training is required to qualify teachers for using this book. The subject can even be successfully introduced in the kindergarten and the nursery. This phonetic mode of initiation in reading cannot be too strongly urged on the attention of School Boards on both sides of the Atlantic.

The ordinary orthography of each word is interlined with the World-English version throughout the Exercises and Readings.

So set down, our tongue is the best for the world to unite upon. — *Brooklyn Eagle*.

The idea of Mr. Bell has much to recommend it, and the presentation is charmingly clear. — *American, Phila.*

The result is a language which cannot fail to meet with acceptance. — *Boston Traveller*.

Has the merit of great ingenuity. — *Railway Age*.

His treatise, as a study of English orthoepy, condenses the result of much thought and experience in small compass. — *The Critic*.

World-English deserves the careful consideration of all serious scholars. — *Modern Language Notes*.

World-English is the English language unburdened of its chaotic spelling. — *Popular Science Monthly*.

We commend it to the attention of teachers. — *Ottawa Globe*.

"World-English" and "Hand-Book of World-English" can be had of all booksellers, or will be sent for 50 cents, post free, by the publisher,

N. D. C. HODGES, 47 Lafayette Place, New York.

Schools.

The Sauveur Summer College OF LANGUAGES.

(Removed from Amherst, Mass., and Oswego, N.Y., to BURLINGTON, VT.)

The Normal Class will be taught for the French by Dr. Sauveur, for the German by Dr. W. Bernhard, for the Latin by Prof. J. U. Dillard.

Dr. Sauveur's new work, LES CHANSONS DE BERANGER, with Historical Commentary and Notes, will be ready June 1, and taught at the School.

DR. L. SAUVEUR, Copley Terrace, Roxbury, Boston, Mass. N.B.—Circulars of Dr. L. SAUVEUR Educational Works will be sent free to applicants.

CONNECTICUT, -NEW HAVEN, MRS. CADY'S SCHOOL FOR YOUNG LADIES. Prepares for Smith and Wellesley, and admits to Vassar by Certificate.

INDIANA, TERRE HAUTE. ROSE POLYTECHNIC INSTITUTE. -A School of Engineering. Well endowed, well equipped departments of Mechanical and Civil Engineering.

NEW JERSEY, PLAINFIELD. THE CHESTNUTS. -Parents with daughters to educate, or orphan girls with companion, may find a comfortable home, with school instruction by applying to Miss E. E. Kenyon.

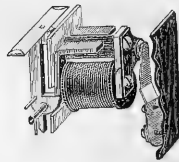

A DROP IN THE PRICE OF

GRAVITY DROP ANNUNCIATORS.

DON'T FORGET THE DUST-PROOF BELLS.

HAZAZER & STANLEY, 32 Frankfort Street, N. Y.

SCIENCE CLUBBING RATES.

10% DISCOUNT. We will allow the above discount to any subscriber to Science of The Swiss Cross who will send us an order for periodicals exceeding \$10, counting each at its full price.

Table with 4 columns: Title, Year's Subscription, With Science, With The Swiss Cross. Lists various magazines and their rates.

Any one who will have the following blank filled out by a responsible Newsdealer, and mailed to us, will be allowed a three months' subscription to Science.

N. D. C. HODGES, 47 LAFAYETTE PLACE, NEW YORK.

To the News Company, 1889.

You may add to my regular order five copies of SCIENCE each week (returnable).



JOHN HASTINGS - Pres't. A-R-R-HART - Gen'l Manager. JOS-TRIPP - V-Pres't. ENGRAVING FOR ALL ILLUSTRATIVE AND ADVERTISING PURPOSES.

BRANCH AT 728 CHESTNUT ST PHILADELPHIA, PA.

67-71 PARK PLACE NEW YORK.

N. D. C. HODGES, 47 Lafayette Place, New York.

C. & C. ELECTRIC MOTOR COMPANY.

Electric Motors
FOR
Arc and Incandescent Circuits, Most Economical Motor on the Market.
Regulation Perfect.
Motors Designed for all Power Purposes.

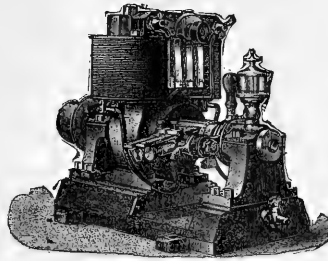

OFFICE and MANUFACTORY:
402 and 404 Greenwich Street, New York City.

New England Office, 19 Pearl St., Boston.

Philadelphia Office, 301 Arch St.

Western Office, 139-141 Adams Street Chicago.

Southern Office, 25 Carondelet Street New Orleans.

"The Week, one of the ablest papers on the continent."—*Descriptive America.*

ENLARGED AND IMPROVED.
THE WEEK:

A Canadian Journal of Politics, Literature, Science and Arts.
PUBLISHED EVERY FRIDAY.
\$3.00 per Year. \$1.00 for Four Months.

THE WEEK has entered on its SIXTH year of publication, greatly enlarged and improved in every respect, rendering it still more worthy the cordial support of every one interested in the maintenance of a first-class literary journal.

The independence in politics and criticism which has characterized THE WEEK ever since its first issue will be rigidly maintained; and unceasing efforts will be made to improve its literary character and increase its value and attractiveness as a journal for the cultured home. Many new and able writers are now, or have promised to become, contributors to its columns, and the constant aim of the Publisher will be to make THE WEEK fully equal to the best literary journals in Britain and the United States.

As heretofore, PROF. GOLDWIN SMITH will, from time to time, contribute articles. London, Paris, Washington and Montreal letters from accomplished correspondents will appear at regular intervals. Special Ottawa Letters will appear during the sessions of Parliament.

THE WEEK in its enlarged form will be the same size as "Harpers' Weekly," and the largest paper of its class on the continent.

SEND FOR FREE SAMPLE COPY.

C. BLACKETT ROBINSON, Publisher,
5 Jordan St., Toronto.

Publications received at Editor's Office,
April 29-May 4.

MICHIGAN State Board of Health, Sixteenth Annual Report of the Secretary of the, for the Fiscal Year ending June 30, 1888. Lansing, State, 328 p. 8¢.

POWELL, J. W. Seventh Annual Report of the United States Geological Survey to the Secretary of the Interior, 1885-86. Washington, Government, 656 p. 4¢.

RAUB, C. G. Psychology as a Natural Science, applied to the Solution of Occult Psychic Phenomena. Philadelphia, Porter & Coates, 541 p. 8¢. \$3.50.

SEYMOUR, T. D. A Concise Vocabulary to the First Six Books of Homer's Iliad. Boston, Ginn, 105 p. 12¢. 50 cents.

SIX Species of North American Fresh-Water Fishes. Washington, D.C., Smithsonian Inst. 18 p. 1¢.

UNITED STATES, Tenth Census of the, 1880. Vol. XXI. Defective, Dependent, and Delinquent Classes. Washington, Government, 581 p. 4¢.

— Same. Vol. XXII. Power and Machinery employed in Manufactures, and the Ice Industry. Washington, Government, 4¢.

VENN, J. The Principles of Empirical or Inductive Logic. London and New York, Macmillan, 594 p. 8¢. \$4.50.

WARNING, Mrs. Clark. The Lion's Share. Chicago, New York, and San Francisco, Belford, Clarke, & Co. 73 p. 12¢.

WENTWORTH, C. A., McLELLAN, J. A., and GLASHAN, J. C. Algebraic Analysis. Part I. Boston, Ginn, 418 p. 12¢. \$1.50.

Scientific Apparatus.

J. GRUNOW,
621 Sixth Avenue, New York.
Established 1852.

MAKER OF
Microscope Stands,
Oil Immersion Objectives and Abbe Condensers for Bacterial and Histological work, of Objectives, Camera Lucida and other accessory apparatus.

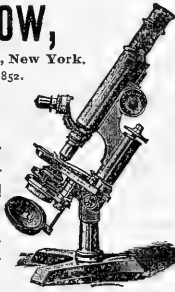

MORRIS EARLE & CO.
SUCCESSORS TO
R. & J. BECK,
1016 Chestnut Street Phila

Microscopes and all Accessories and Apparatus. Photographic and Photo-Micrographic Apparatus and Outfits.
Spectacles, Eye Glasses, Opera and Marine Glasses, etc.
Illustrated Price List mailed free to any address. Mention SCIENCE in corresponding with us.



IMPROVED OIL LIGHT
MAGIC LANTERNS.

Also Lime and Electric Light Apparatus, and mechanical, plain, and fine colored views.

J. B. COLT & CO., Manufacturers,
No. 16 BEEKMAN STREET, NEW YORK.



E. H. T. ANTHONY & CO.
591 Broadway, N.Y.

Manufacturers and Importers of
PHOTOGRAPHIC INSTRUMENTS,
Apparatus and Supplies of every description. Sole proprietors of the Patent Detective, Fairy, No. 1, and Bicycle Cameras, and the Celebrated Stanley Dry Plates.
Amateur Outfits in great variety, from \$5.00 upward. Send for Catalogue or call and examine. ²⁵ More than 40 years established in this line of business.



GOOD NEWS TO LADIES.

Greatest Inducements ever offered. Now's your time to get up orders for our celebrated **Teas and Coffees**, and secure a beautiful **Gold Band** or **Moss Rose China Tea Set**, **Dinner Set**, or **Webster's Dictionary**. For full particulars address **THE GREAT AMERICAN TEA CO.,** P. O. Box 239, 81 and 83 Vesey St., New York.

MAGIC LANTERNS Stereotypes and the Best Views for Public, Church, Home, and Scientific Exhibitions. Best apparatus, new views. Largest stock. Reduced prices. 24 Years' Practical Experience. Illus. Catalogue Free.
GEO. H. PIERCE,
136 S. Eleventh St., Philadelphia, Pa.

ELECTRICAL TESTING BUREAU,

Johns Hopkins University, Baltimore, Md.
Resistance Coils and Boxes Compared.
Am meters and Volt meters calibrated.
Condensers standardized.
Primary and Secondary Batteries Tested.
Efficiency of Dynamos and Motors Determined.
Insulation of Cables and Wires Tested.
Etc., Etc.
Circulars describing Methods Used, Prices, Etc., sent on Application.
Address as above.

A TEMPORARY BINDER

for Science is now ready, and will be mailed postpaid on receipt of price.



Half Morocco - 75 cents.
This binder is strong, durable and elegant, has gilt side-title, and allows the opening of the pages perfectly flat. Any number can be taken out or replaced without disturbing the others, and the papers are not mutilated for subsequent permanent binding. Filed in this binder, Science is always convenient for reference.

N. D. C. HODGES,
47 Lafayette Place, N. Y.

Readers of Science
Corresponding with or visiting Advertisers, will confer a great favor by mentioning this paper.

Arnold, Constable & Co.

COTTON DRESS STUFFS.

D. & J. ANDERSON'S
CELEBRATED

ZEPHYRS,

for beauty of texture, coloring and durability, are unsurpassed.

FRERES KOECHLIN'S
Crepe Cloths, Marie Antoinettes,
Printed Sateens, Toile-a-Voile.

Broadway & 19th St.
New York.

COLORED SILKS

We have just made one purchase of 35,000 yards of Plain Colored Silks, 19 inches wide, in 40 different shades. The entire lot has been placed this week in our Retail Silk Department. The price is 65 cts. per yard; the goods are fully worth 95 cts.

We know of no occasion when so large a quantity and so excellent a quality of Colored Silks has been offered at retail in New York City, for so little money.

Samples sent on request.

JAMES McCREERY & CO.

BROADWAY AND ELEVENTH STREET,
NEW YORK.

IMPROVING THE MEMORY PICK

and facilitating the acquirement of knowledge by lectures and correspondence. Classes forming. "MEMORY and its Doctors," from Simonides to "Loisette," mailed for 10 cents.
DR. PICK, 24 Union Square, N. Y. City.

FOOD ADULTERATION

And its Detection. With photomicrographic plates and a bibliographical appendix. By J. P. Battershall, 328 pages, 8vo, cloth. Price, \$3.50. Circulars and Catalogues on application. E. & F. N. SPON,
12 Cortlandt St., New York.

A NEW MAGAZINE—THE SWISS CROSS
Devoted to spreading a love of nature among the people. Edited by HARLAN H. BALLARD, President of the Aegassiz Association, and succeeding St. Nicholas as the official magazine of that body. \$1.00 a year. Sample copy 10 cents, or 25 cents for trial subscription for 3 months.
N. D. C. HODGES, PUBLISHER.
Mention this paper. 47 Lafayette Place, New York.

The Mutual Life Insurance Company

OF NEW YORK.

RICHARD A. McCURDY, PRESIDENT.

ASSETS - - - \$126,082,153.56

The Largest and best Life Insurance Company in the World.

The New Business of the Mutual Life Insurance Company in 1888
Exceeded \$103,000,000.

Its Business shows the Greatest Comparative Gain made by any Company during the past year including

A gain in assets of	\$ 7,275,301 68
A gain in income of	3,096,010 06
A gain in new premiums of	2,333,406 00
A gain in surplus of	1,645,622 11
A gain in new business of	33,756,792 85
A gain of risks in force	54,496,251 85

The Mutual Life Insurance Company

Has Paid to Policy-holders since Organization \$272,481,839 82.

PARIS EXPOSITION.

The Cheque Bank issues Cheques, either singly or put up in Books, for the special use of VISITORS to the PARIS EXPOSITION, who can cash the same at upwards of seventy Banking Houses, situated in different parts of Paris, without charge.

Visitors' mail matter can be addressed to them, Care of the Societe Generale, 4 Place de l'Opera, opposite the Grand Hotel, where English is spoken.

Every Cheque that is issued by the Cheque Bank is EQUAL TO CASH, as Bank Notes are, for the Bank's Capital, Guarantee Fund and Customers' Balances are invested in British Government Securities, or held in Cash in the Bank of England, and can be cashed in every town in Europe without charge.

For Handbook containing list of 2,500 Banking Houses who cash the cheques, free of charge, apply to

CHEQUE BANK, Limited,
Capital, £100,000. Guarantee Fund, £27,000.
Trustees, The Right Honourable John Bright, M.P.,
The Right Honourable Earl Beauchamp.
NO. 2 WALL STREET, NEW YORK.

Visitors to Europe and Paris Exposition should carry a book containing Cheque Bank Cheques, which are absolutely safe and cheaper than Letters of Credit, and much more convenient; are payable on presentation without charge at 2,500 Banking Houses and 250 of the principal Hotels in Europe.

A RARE CHANCE FOR A COLLEGE.

For sale—1,300 FINE COINS and MEDALS, silver, gold, bronze, a history in coins commencing with the fifteenth century, representing over 500 historical persons and 175 countries and cities. Address
L. D., P.O. Box 1337, New York.

Old and Rare Books.

One Million Magazines. Back numbers, vols. and sets—old and new, Foreign and American.
CATALOGUE UPON APPLICATION.
A. S. CLARK,
34 Park Row, New York City.

BACK NUMBERS and complete sets of leading Magazines. Rates low. AM. MAG. EXCHANGE, Schokarie, N.Y.

H. WILLIAMS,

Dealer in Old Magazines, Reviews, &c. Scientific periodicals a specialty. 39 Macdougall St., N.Y.

Wants.

A YOUNG MAN can have lucrative engagement, not only a fixed salary, but according to his work accomplished in travelling for SCIENCE. A personal interview invited.

N. D. C. HODGES,
47 Lafayette Place, New York.

Readers of Science

Corresponding with or visiting Advertisers will confer a great favor by mentioning the paper.



**KIMBALL'S
STRAIGHT CUT
CIGARETTES.**

Unsurpassed in quality. Used by people of refined taste. Highest award at Brussels, 1888. The finest smoking mixtures are of our manufacture. Fifteen First Prize Medals. WM. S. KIMBALL & CO., Rochester, N.Y.

SCOTT'S EMULSION

OF PURE COD LIVER OIL AND HYPOPHOSPHITES

Almost as Palatable as Milk.

Containing the stimulating properties of the Hypophosphites combined with the Fattening and Strengthening qualities of Cod Liver Oil, the potency of both being largely increased.

A Remedy for Consumption.
For Wasting in Children.
For Scrofulous Affections.
For Anæmia and Debility.
For Coughs, Colds & Throat Affections.

In fact, ALL diseases where there is an inflammation of the Throat and Lungs, a WASTING OF THE FLESH, and a WANT OF NERVE POWER, nothing in the world equals this palatable Emulsion.

SOLD BY ALL DRUGGISTS.

SCIENCE

[Entered at the Post-Office of New York, N. Y., as Second-Class Matter.]

No. 133620
MAY 20 1889
U.S. DEPT. OF AGRICULTURE

U.S. DEPT. OF AGRICULTURE
MAY 20 1889
U.S. DEPT. OF AGRICULTURE

A WEEKLY NEWSPAPER OF ALL THE ARTS AND SCIENCES.

SEVENTH YEAR.
VOL. XIII. No. 323.

NEW YORK, MAY 17, 1889.

SINGLE COPIES, TEN CENTS.
\$3.50 PER YEAR, IN ADVANCE.

AMATEUR PHOTOGRAPHY AND ITS POSSIBILITIES.

An opportunity is furnished by photography for beautiful picture-making, not only in original conception, but in imitation.

Take some fine head painted by an old master, study the light and shade upon it, the character of the face, the quality of the background. Then choose from among your friends one whose type is somewhat like that of the one in the picture, and arrange with great care the light on head and face, and neck and shoulders. The arrangement of each detail of the drapery is also important; and, with such care, there is nothing to prevent your getting an interesting negative. If there is a dimness over the picture, and you want to carry out even that idea, you can do so by putting your lens slightly out of focus. That will eliminate some of the detail, and produce the desired softness and dimness.

Try the same person in many poses, if you can get some one to sit for you who will willingly lend himself for a time to your experiments. Try a head somewhat like the one in Fig. 2 in various positions, — bent down, as is this, as if in meditation or prayer, with a strong side-light on the face, no reflected light on the head, and the whole against a gray background. Then try the same head upturned in profile, with no reflected light, and with a black background. Then, again, try a full face, with strong light and shade, and with a different background still, and see how much you have made from the same person.

You can produce quite different effects by the careful management of the light from one high side-light, either using the upper half of the window by curtaining the lower half, or using the lower half and having a direct side-light upon your sitter; or, yet again, by leaving the whole window uncurtained. You must always be very careful about reflected lights, which are an important part of picture-making. One way of reflecting is by arranging a screen on the shadow-side of your sitter, and throwing over that a sheet. By putting the screen, so arranged, very near to the sitter, you will get a full, even, reflected light. By moving it away, a lesser light will be cast over the shadow of the face. Sometimes a looking-glass is used; but that produces an unnatural light, which is not so desirable as the reflection from a duller surface. There is a very easy way of throwing a little light under the brow and nose and chin. It may be done by laying a card or an open book in the lap of the sitter, or by asking him to hold one in the right position. Do not be afraid, however, of shadows. Learn to manage them skillfully, making them heavy enough to give force and character where needed, and light enough to bring out delicate lines in their places.

Try now to imitate, in part or in detail, a Holbein portrait of a child. Arrange your light as in the chosen picture; and if the child have a fair, smooth skin, a most charming effect of finished surface can be made with a mellow, rich light flooding the little



FIG. 1.—PORTRAIT OF A CHILD, AFTER HOLBEIN'S METHOD.

child have a fair, smooth skin, a most charming effect of finished surface can be made with a mellow, rich light flooding the little

face. Fig. 1 is somewhat after Holbein's method, although no particular picture was chosen for imitation. This photograph was taken in a bay-window with a great deal of light. The child's skin was very fair and smooth, the eyes a hazel, every feature very clearly cut. An old-fashioned dress was chosen; and were it not for the shadow on the neck, which is much too dark, the idea I had in mind was quite fairly carried out. Always there is danger that some point will be overlooked in the arranging, some spot of light or shade forgotten, and there is where much thought is needed. Think your picture well out beforehand, so as not to keep the sitter unnecessarily long. When the time arrives for the taking, arrange quickly and deftly your subject, having the means

was developed and I took it out into the light of day, "Oh! ain't I a pretty little thing?" She was surely a very smiling, good little child, as she sat for the picture.

It is not necessary to keep to heads in this matter of imitation. Try figures and groups, if you like. But the more you have in your picture, the more difficult it will be. The best way is to begin with a head, simply lighted, and work with that until you get a fair imitation of some good picture.

If you have a quick-working lens, try a picture with a baby in it. This is an ambitious thing to do. But take one of Andrea del Sarto's pictures of the "Madonna and Child," and plan to make a photograph as nearly like it as possible. One sometimes sees



FIG. 2.

of reflecting light and darkening background near at hand, your camera in good order, your lens clean. Then hope for the best, and take off the cap. Always there are disappointments in store. It would be strange were there not. But also there is the certainty of making the disappointments less by sufficient care.

From the older painters, come down a few centuries to more modern ones. Take, for instance, one of Sir Joshua Reynolds's pictures of a child. Here, indeed, is a charming field for you to enter upon. Fig. 3 is taken somewhat after the manner of Sir Joshua. It is by no means a direct imitation, but some of his pictures were in my mind at the time, and half seriously it has been called "After Sir Joshua" by several friends. It was hastily taken, in a poor side-light. The dress was improvised at the moment. The child was an amiable little sitter, and, in a quite unconscious way, much pleased with the result, remarking, when the negative

faces of the Madonna type, — gentle, mild-eyed women, with pure, delicately cut features. Have the woman dressed like the one in your picture; the lights, backgrounds, and all accessories carefully arranged, except the little child, who should be introduced at the last moment, and posed as nearly as possible like the child in the picture. Then focus quickly, and take your picture. You should do this thing very well, or not at all. It needs great skill; and a careful study of composition and light and shade should go first.

There are charming Van Dykes to imitate, Rembrandts, Holbeins, Andrea del Sartos, Copleys, and Stuarts. There are also some exquisite modern pictures which it would do you no harm to study. If you are an art-student, you can help your art very much by studying pictures in this way. You will learn how persons far wiser than you, have managed their light and shade, how beautifully

they have posed their subjects, how they have taken thought of every important line.

This of which I have written is a branch of photography which has been but little attempted, and it is certainly worth notice; worth entering upon, if your taste leads you in this way, with earnestness and enthusiasm.

Laura M. Marquand.

IMPROVEMENTS IN THE BENTLEY-KNIGHT ELECTRIC RAILWAY SYSTEM.

IN *Science* of Jan. 18 we described the electric railway on Observatory Hill, Allegheny City, Penn., equipped by the Bentley-Knight Company, and illustrated the motor trucks in use on that line. In this number we give a plan and elevation of a double-

from the wheels. The spring support makes the wear less, while allowing the motors to give a yielding impact to the load at starting. The commutator-brushes are fixed in position when the motor is first adjusted, and need no further adjustment.

While the Bentley-Knight Company has paid considerable attention to conduit construction, and has laid and operated successfully such systems, and claims to control that system by many patents, it is a mistaken idea to believe that it confines its attention to such lines; the Allegheny City line being, in part at least, an elevated-conductor road. The grades, curves, and general difficulties of that road we have already referred to. In Boston, the Bentley-Knight motors, while running over three miles of conduit, are also running over twelve miles of elevated conductors. This company has lately taken the contract for the Port Chester, White Plains, and Tarrytown Street Railway, crossing Westchester



FIG. 3.

motor truck, which is considered an improvement on that previously described, and which is now in use on the West End Street Railway Company's line in Boston (see p. 374).

Each motor is of fifteen horse-power. The trucks are the heaviest yet built and operated for electric tramway service, and are used to pull two cars on week days, and three cars on Sundays. They are equally well adapted for use with elevated conductors or with the conduit system, although our illustration shows them as equipped for the latter. The insulation has been carried to a high point. The truck is independent of the car-body, and goes under any ordinary car without alteration and without raising a car above its ordinary height. Control is effected by a lever on the front platform. The reversal of the car may be instantly effected, and during this reversal the current is automatically cut off.

As is seen by the illustration, the motors themselves, together with all gearing, are supported outside between the spaces of the axles of the car, giving ease in getting at the wearing parts, and enabling the motors to be carried in a position where they are least in the way, and least exposed to splashes of mud and water

County, upon which line heavy double-motor trucks, similar to the one described in this number, will be employed.

THE June number of *The Chautauquan* presents a wide variety of topics in its table of contents. William P. Trent, M.A., of the University of the South, discusses "The Position of Women in Ancient Greece;" the ninth in the series of Greek biographical sketches by Thomas D. Seymour, M.A., of Yale University, has for its subject "Ptolemy Soter;" Russell Sturgis finishes his two-part paper on "The Archæologist in Greece;" the Rev. J. G. Wood describes some "Odd Fishes;" Albert Shaw, Ph.D., contributes an article on "European Town Life;" Professor Charles J. Little, LL.D., of Syracuse University, concludes his two-part paper on "The Paris Mob and its Achievements;" the Hon. A. B. Richmond denounces the "license curse" in "The Relation of Rum to Crime;" Mrs. Carl Barus writes entertainingly of "Oriental Legations at Washington;" and Ripley Hitchcock recounts his experiences "At the Head of the Rails" in the Black Cañon of the Gunnison.

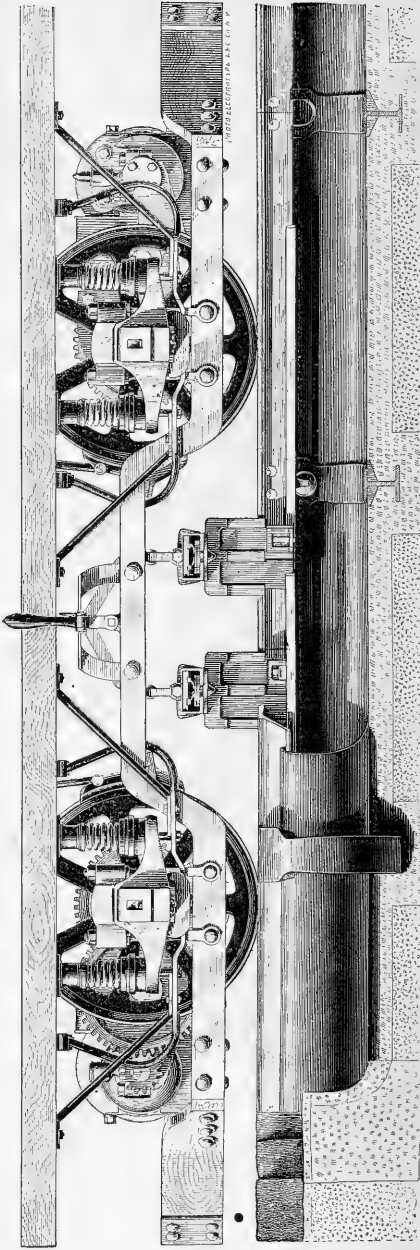
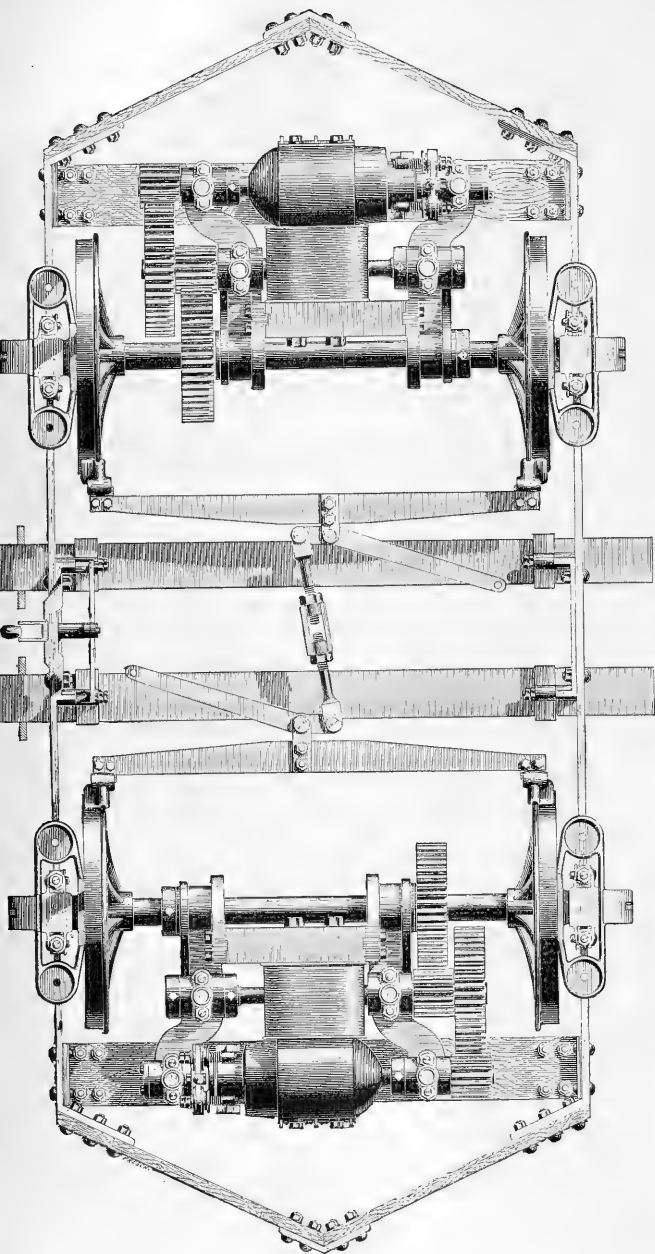

THE BENTLEY-KNIGHT DOUBLE-MOTOR TRUCK, ELEVATION AND PLAN. [See preceding page.]

RAILWAYS IN CHINA.

EVER since the opening of the treaty ports, the attention of foreigners in China has been attracted to the development of the means of intercommunication in a country where the engineering difficulties to be encountered are comparatively small. The frequent recurrence of famine over the vast area of China, the enormous difficulties of transport with the consequent delay and uncertainty in conveying relief, and the increased price of all commodities in a ratio out of all proportion to the distance from the area of production, offered such strong arguments for the introduction of railways, that it seemed impossible even for Chinese prejudice to withstand them, provided any feasible scheme could be produced. The history of railways in China is given in the May number of *The Contemporary Review*, in an article by Mr. Charles S. Addis. The most practical method appeared to be by way of demonstration, and accordingly a small line was constructed between Shanghai and Wusung, a distance of thirteen miles. In December, 1876, the line was opened for traffic under a convention between the governments of Great Britain and China, and for some time met with a fair measure of success. From December to October, 175,995 tickets were issued, and the sum of \$38,258.78 was realized by their sale. Happily no casualty of any kind happened to passengers, and the promoters of the railway had reason to congratulate themselves on the complete success of their undertaking. But they had underestimated the intense conservatism of the Chinese character, the dislike which such an innovation was sure to arouse among a nation profoundly affected by an ancient system of geomancy, and imbued with a traditional reverence for the places of the dead, and, above all, the opposition to be encountered from the host of carriers by road and canal, already jealous of the slightest interference with their means of livelihood. With such potent influences arrayed against it, the railway bantling could hardly be long-lived. It lasted barely a year. On Oct. 20, 1877, the Chinese authorities purchased the line. The rails were torn up, the permanent way was destroyed, and the remains of the first railway in China are now lying rusting on the Formosan beach.

Meanwhile events had been moving rapidly. China had formally entered the comity of nations. Her political relations with foreign powers were becoming closer and more involved. Emigrants were annually departing from her shores in increasing numbers to Australasia, the Straits Settlements, the United States, and Peru, and their care formed an additional and growing tax upon the resources of Chinese diplomacy. The national cohesion could not long withstand the disintegrating processes at work, and the barriers of ancient exclusiveness were crumbling away as surely and more rapidly than the Great Wall itself. It became necessary to appoint ambassadors and consuls at foreign courts and at those places where large numbers of Chinese subjects had settled. It was soon found that Celestial diplomacy could hold its own against that of the West, but it was felt to be intolerable that all the advantages of a rapid means of communication should be on the side of the barbarian. The telegraph-wire, at any rate, soared above the gods of the earth and the spirits of ancestors at rest within the tomb. It interfered with no man's property, and not even the most superstitious of the censors had a valid objection to offer. In fact, all that was required was a fair start; and, that once obtained, the wires "forged ahead" until in 1884 there were 3,089 miles of line open, and the imperial authorities at Peking found themselves in direct communication with the Marquis Tseng, who was then their representative in Great Britain.

This was a great step in advance, and quite in keeping with the Chinese method of reversing the procedure of other countries. For once, the telegraph had given a lead to the railway, and other influences were at work to hasten its lagging steps. The veteran warrior and statesman, Tso Tsung-t'ang, lay sick at Foochow. He had seen the masterly subjugation of the rebels in Kashgaria during the long years between 1871 and 1877, where also his own victories had won for him a place in Chinese history beside the most famous generals of old. The Taiping rebellion had received its death-blow at Gordon's hand, but the constant fear of Russian encroachments on the Mongolian frontier, the extreme delicacy and even danger of China's relations with Japan, the restlessness of

Corea under the imperial suzerainty, and the impending difficulties with France, filled his patriotic soul with trouble. It may be that with the prescience begotten by approaching death he foresaw the perilous times in store for his country, when France should reach her frontier on the south, when Great Britain should touch her borders on the west, and Russia should approach as near on the north. He was passing away, and on whom was his mantle to fall? His own difficulties in grappling with an internal war had been heavy enough, but who could save China in the future, when her enemies hemmed her in on every side? In a most touching memorial to the throne, penned shortly before his death, he reviewed the situation, and, with all the weight of his tried patriotism and experience, urged the construction of railways as a first means of safety for his country. The appeal could not pass unheeded by either his countrymen or the government. The effect on public opinion of such an utterance from one of China's noblest and most trusted sons, with all the weight lent by his subsequent decease, was indeed enormous. It soon became known that the Viceroy of Chihli, and his *protégé* the Viceroy of Formosa, were in favor of the project. In 1887 the Marquis Tseng returned from his duties abroad to take up an important position in the capital, and to throw all his additional knowledge and experience on the side of reform. The same year an historical event happened which had an important bearing on the case. For the first time a prince of the royal blood visited a foreign settlement. Prince Ch'un, who is the father of the present emperor, and a man of liberal views, journeyed as far south as Chefoo to inspect the Chinese fleet. For the first time in his life he came in contact with foreigners, and was able to see for himself the value of modern inventions. On his return to Peking, he laid the results of his journey before the dowager empress, and it soon became known that this wise and astute lady was also on the side of progress. The body of censors, who there perform the functions of a parliamentary opposition with England, were ominously silent,—a sure sign of their consciousness that any protests of theirs would be ill received at court. In a word, the times seemed ripe, and, after one or two preliminary memorials, the imperial rescript was issued in March of last year, and the die was cast. For the first time official sanction was obtained for the novel undertaking, and nothing remained but to put it into execution. The matter was happily intrusted to Li Hung-chang, by far the most enlightened and able statesman in China, and in his hands it was felt that success was assured.

But he had set himself a difficult task. To allay the hostility and smooth the susceptibilities of a conservative and superstitious people demanded all the care and tact at his command. The slightest mistake might mean failure, and to insure success the greatest caution was necessary. His first step was to familiarize the people gradually with the new means of locomotion. The year before the rescript was granted, a small railway on the Decauville system was laid at Tientsin, and for a few cents the public were whirled round a circle of two or three miles. The snorting little engine was found, on acquaintance, to be not such a very dreadful object, after all, and for several months curious and delighted crowds thronged the carriages. Meanwhile, Liu Ming-ch'uan had not been idle in Formosa, and a line of strategic railway was being constructed in the very country where a few years before the old Wusung rails had been thrown down in contempt. The third and most important step, however, was made in Li Hung-chang's own province of Chihli. Tong King-sing, a man of great ability and with a taste for Western inventions, had opened at Tongshan the first colliery in China worked on foreign principles. The engineer-in-chief was Mr. C. W. Kinder, a man thoroughly honest, able, and reliable. Under his management, a railway had been constructed to convey the coal from the mine to the port of shipment, some twenty miles distant, and at this the authorities had been content to wink. Here, then, was a man ready to hand, and to him accordingly Li Hung-chang applied. The China Railway Company was formed, with Chinese directors indeed, but with European engineers, and work was at once commenced. "*T'ieh lu lai lai*" ("The railways are coming"), said Prince Kung once to Dr. Wells Williams at Peking. A decade and more has passed since then, and at last the prince sees his prophecy fulfilled.

The Tongshan line has now been extended until a distance of 81

miles has been completed: viz., Tientsin to Tongku, 27 miles; Tongku to Lutai, 25 miles; and Lutai to Tongshan, 29 miles. In addition, there are 5 miles of sidings and branches. The line is a single one, the rails are of steel, and the gauge throughout is the 4 feet 8½ inches common in Great Britain. The four passenger and seven tank locomotives were, with one exception, imported from England.

Financially there is every reason for believing that the new railway will be a success. The small Tongshan line has already paid a dividend of 6 per cent, and the extension will add enormously to its profits, tapping as it does a populous stretch of country and a busy centre of commerce like Tientsin. An additional feature is the extreme cheapness with which the line has been constructed. The country through which it passes is flat and marshy, and in certain seasons of the year liable to inundations. In consequence of this, an embankment of 8 feet in altitude was in some places required, some fifty bridges had to be constructed, and an extensive system of water-channels was found necessary. Bearing this in mind, the total cost so far—viz., a million and a half of taels, or, say, under £4,300, per mile—is exceedingly small, and reflects the greatest credit on Mr. Kinder and his staff.

A comparison between the Japanese and the Chinese is a favorite theme with travellers, who never tire of contrasting the former's rapid strides with China's timid steps along the path of progress. No doubt Japan is far ahead of China in all modern improvements, but her pioneering has been expensive work, and China has profited by her experience. The first railway in Japan, from Tokio to Yokohama, a distance of 18 miles, was completed in 1880, at a cost of £34,263 per mile. The difference in cost of the two railways is certainly remarkable, but the detailed items of expenditure are not sufficiently numerous to enable one to form an accurate comparison. The engineering difficulties of the Japan line were apparently no greater than in China, and the gauge was only 3 feet 6 inches, as opposed to the 4 feet 8½ inches of China. On the other hand, the line was a double one; but, after every allowance is made, it seems evident that the Japanese were heavily fleeced in their first railway contracts, and that the Chinese have profited by the experience of their neighbors.

In the numerous troubles and even riots that arose as the railway pushed its way past mouldering graves and through the well-tilled fields, the viceroy found an able ally in Wu Ting-fang, a man of great tact and energy. Combining the *suaviter in modo* with the *fortiter in re*, he managed with success to conciliate the prejudices of the small farmers, the bones of whose ancestors he was about to disturb. Wu Ting-fang spent some years in England, and qualified himself with honors as an English barrister-at-law. The management of the railway is now virtually in his hands, and his foreign experience should stand him in good stead.

At the end of September the new line was opened for traffic, and trains are now running daily over the whole distance. Tickets have been printed, a time-table published in the *Chinese Times*, and crowds of natives are already availing themselves of the novel mode of conveyance. The engine-drivers are as yet Europeans; but the Chinese have shown a remarkable aptitude for work of this kind, and may soon be expected to replace their foreign competitors.

On the 9th of October, Li Hung-chang made his first journey of inspection. He was received at the Tientsin station by the foreign engineers and by an imposing array of Chinese officials clad in their robes of state. A body of foreign-drilled troops was stationed for some distance along the line, and, by their smart appearance and soldierly bearing, formed a striking contrast to the native braves, armed with ancient gingsals and bows, and dressed in tawdry uniforms of black and yellow. The viceroy entered the handsome saloon carriage built for him, and, amidst a *feu de joie* from the soldiers, steamed out of the station at 8 A.M. The carriage is provided with a bedroom, a lavatory, and rooms for the viceroy's suite. The teak furniture was supplied by a firm of upholsterers at Shanghai, and the general decorations are tasteful and handsome. The viceroy showed a lively interest in the new work, and, to facilitate his inspection, the train proceeded slowly; but during one part of the journey he was bowled along at the rate of fifty

miles an hour, and this speed could easily have been increased. After a short rest at Tongshan, his Excellency returned to Tientsin, much pleased with the result of his visit. It would have been extremely unfortunate had any thing occurred to excite Chinese fears or prejudices, but happily the trial passed off without a hitch. A formal report has been ordered to be submitted to the Throne and to Prince Ch'un. Its tenor will undoubtedly be entirely favorable, and the railway system will receive its *imprimatur* immediately.

The first railway in China—the Wusung affair was merely an experiment—has thus been brought to a triumphant conclusion. With the record of previous failure before us, we must guard against being too sanguine, but for this railway there is no need to fear such a catastrophe as that of Wusung. It is not a foreign, but a Chinese undertaking, with native directors, who will be shrewd enough to protect their own interests; and obviously it rests on a sounder basis. Its slow growth affords the surer hope of its stability, and it needs no prophet to foretell that once more China is entering on a new era of civilization. Still, it is believed, the growth will be slow, and until the capital is reached it is unlikely that any comprehensive scheme will be adopted. China has as yet only tasted the advantages of Western civilization, but the morsel has been large enough to excite her appetite for more. If Taku were again threatened, troops could now be poured in by the railway, and the capture of the forts would be a more serious matter than it was in 1860-61. But Taku is not the only vulnerable point, and the railway must be extended to Shanhai-kuan, which lies some eighty miles in an opposite direction, before the defences of the capital can be considered complete. It is practically settled, already, however, that the first extension shall be some seventy miles north to T'ung-chou, an old port on the Peiho, fifteen miles from Peking. The provincial officials who are continually travelling to and from the capital on business, and the crowd of undergraduates who go there to be examined, can now sail from the south to Taku in a comfortable foreign steamer. As soon as the extension is completed, they will be able to traverse the distance between Taku and T'ung-chou with an ease and rapidity in striking contrast to the painful and tardy journey by cart to which they have hitherto been accustomed. At T'ung-chou they will be forced to disembark, and endure the torture of driving in a Peking cart over the thirteen miles of stone road by which Marco Polo travelled more than six hundred years ago. No one who has not made that journey can realize what it is to be cooped up in a springless cart, like an enlarged dog-kennel placed on wheels, and to be bumped and jolted over these blocks of masonry, one wheel now high in the air, rattling the unfortunate traveller's head against one side of the cart, and anon sinking deep in a bog, to send him flying with a lurch to the other, until, bruised and bewildered, he sees the gates of Peking loom in sight, and, with a sigh of relief, endures a final jolt as he passes under the ponderous archway. That journey will be the motor muscle of railway extension. Human nature, even Chinese human nature, will not long endure the anomaly of spending three hours of peace and comfort over the first 130 miles of a journey, and three hours of pain and torture in covering the last 13 miles. The discomfort of it is a blessing in disguise; and when the Peking station is opened, and the railway-whistle shrieks as we near its ancient walls, we shall draw our rug closer about us, and bless the old road for what it has brought. Once the exclusion of the capital is broken down, who can predict what will follow? The growth, as has been said, will be slow, and it is well that it should be so. No grand trunk lines will be attempted until repeated small extensions have been proved a success. That success may be considered assured, but the Chinese are right to prove it for themselves. And as the years roll on, we may conclude that first one province and then another will fall under the sway of the Iron King, until an arterial system of railways shall bear new life and vigor to every extremity of corporate China, and she wakes once more to feel her old strength, but with it a new potentiality for the safety and peace of her people.

With regard to the results which will spring from the introduction of railways in China, we may find a fair parallel in the benefits which have accrued to India since they were established there. Agriculture will receive a much-needed impetus, rebellions will be

made impossible, the food of the common people will be cheapened, their luxuries increased, their standard of comfort raised, and the famine demon will depart, never to return. Wider and more general information will be diffused throughout the empire, and, with enlarged knowledge and sympathy, the old-time ignorance and exclusiveness will disappear. But with the peculiar conditions of Chinese civilization, reforms more interesting and unique than these will certainly follow.

From the difficulty and expense of travel, the inhabitants of the various provinces have been born and brought up in a state of seclusion beyond modern experience. A Chinaman is, as a rule, born and buried within a radius of a few miles. Practically he is a stranger to his neighbor, and an astonishing variety of language is the result. In all, there are nearly 300 dialects spoken in China, many of which are as different as French and English. It is not uncommon to see a southern Chinaman meet a countryman from the north, each utterly unable to comprehend the speech of the other. The facilitation of travel must, in course of time, do much to mitigate this babel of tongues, and the necessities of the case must produce some modification of one of the principal dialects, from which a new universal language for China will be evolved. This hope seems the more reasonable, as the written language is the same all over China. There is also a fainter hope of a reform in the written language itself; and perhaps a later generation may know the blessings of an alphabet, and exchange the present cumbrous and involved ideographs for a system of phonetic romanization.

Railways will also produce an entire reform in the Chinese currency. The same reasons which have produced a variety of languages have also conserved the most bewildering varieties of weights and measures. There are no coins of any kind, with the exception of small brass and iron *cash*, of which from ten to twenty, or even more, are equal to a penny. For all large payments, lumps of silver are employed, which are generally, for convenience sake, moulded into the form of a shoe. In making a purchase, you produce your silver, and, after one lengthened dispute as to its quality, you enter upon discussion number two as to the particular measure of weight to be employed, of which there may be several. In Peking, for instance, there are no less than five in common use. All this, of course, occupies much time, and it would be manifestly impossible for the train to wait while a bevy of passengers were conducting the purchase of their tickets in this way. A coinage will have to be adopted. The standard chosen will probably be a coin of silver, of one tael in weight, and equal to about \$1.08 of our money, and the smaller coins will be in decimal proportion. The convenience to the country and benefit to commerce of the new currency will be felt from one end of China to the other.

It will be necessary also to adopt a foreign standard of time. At the treaty ports there is a ready sale for cheap clocks and watches, and the Chinese who have dealings with foreigners have not been slow to appreciate their convenience. In Peking there is a considerable number of watchmakers, descendants of old Catholic families, who still practise the somewhat antiquated horology which their fathers learned from the early Jesuit missionaries. But the system in vogue throughout China remains unchanged from the days of antiquity. The entire day is divided into twelve periods of two hours each, beginning at 11 P.M. Each period is known by the name of some animal, and is further divided into eight *chih's*, corresponding to our quarters of an hour. The nights are, in addition, divided into five watches, which the patrols ring out from wooden drums; but there is no smaller subdivision than the *chih*. For time-keepers they have sun-dials, or clepsydras, or spiral incense-sticks, arranged, like King Alfred's hour-candles, to burn for a certain length of time. If you ask the time of day, you will be told that it is near the dog, or two-eighths from the rat; but more approximately than that, you cannot get. It is curious that a people so industrious as the Chinese, and so studiously economical in their habits, should never have a juster estimate of the value of time. To them, so far from time being money, money is every thing, and time nothing. He who aims at being the *superior man*, whom Confucius held up as a model for all time, must never be in a hurry. Every thing must be done in a dignified and de-

liberate manner, and the idea of a quarter of an hour, more or less, making the slightest difference to himself or any one else, has not yet entered the Celestial cranium. It will be one of the greatest surprises in the life of a mandarin when he first stalks down to the railway-station, and finds that the train is timed to start to the minute, and will wait for no man. Happily, there can be no objection, superstitious or otherwise, to the introduction of timepieces, and the railway clock will be the precursor of a new punctuality and despatch in China.

Changes so far-reaching and profound as these cannot fail to produce a sensible modification of the Chinese character. The odium and contempt in which foreigners are held, simply because they are foreigners, will melt away as opportunities for intercourse increase.

As yet the question has been considered only from the Chinese point of view. The interesting point is that the new railway sounds the death-knell of Chinese exclusiveness. The empire can no longer remain sealed, and now is the time for England to consider if she is in the best position for taking advantage of the vast field of commerce which may shortly be thrown open. English consuls have recently borne a singularly unanimous testimony to the apathy of the British trader, and he must be on the *qui vive* now if he does not wish to see the benefits of the coming change pass into the hands of others. To begin with, the Chinese are totally unacquainted with modern engineering, and the railway construction of the immediate future must be done for them by foreigners. Both with engineers and traders, a serious difficulty will be the want of men familiar with the Chinese language and mode of thought. For several years past, the professor of Chinese at King's College has labored, with a zeal and enthusiasm which deserved a better return, to supply this want. To meet the convenience of clerks and others unable to attend during the day, a series of evening classes was started, of which the first-fruits may be seen in the successful career of some of Mr. Douglas's old students in China. But these may be counted upon the fingers of one hand, and the general result must be pronounced disappointing. Probably no attempt by an English professor to teach an Oriental language without the aid of a native assistant is likely to be completely successful. But this is a desideratum which could and should be easily supplied. A greater, and alas! almost insuperable difficulty remains in the apathy and indifference of those in whom indifference is least excusable. Foreign clerks employed in England arrive with a general knowledge of two or more languages, while your Englishman is accustomed to hold in contempt all languages except his own, and even to feel a certain pride in his ignorance. His neighbors are more quick-witted. Men are drafted off to China from the Oriental College at Paris, who, on their arrival, exhibit a very passable acquaintance with the rudiments of the Chinese language. A similar college has just been opened at Berlin; and the chair of Chinese is filled by Professor Arendt, a sinologue of the highest standing. True, England has professors of Chinese at her universities, but the teaching given is too scientific to be of much use to commercial men. Business men have neither the time nor the inclination to form even a tolerable acquaintance with Chinese literature or the flowers of official discourse. It must not be forgotten that the written language, the language spoken among officials, and the ordinary colloquial, are practically three different tongues. It is the last which is necessary, and happily the colloquial is well within the reach of any one who cares to approach it in a spirit of patience and perseverance. With a Chinese teacher, under the supervision of a European sinologue, a two-years' course would be sufficient to equip any one of ordinary ability and application with a fair talking knowledge of the colloquial, which would prove of immense service to him in China. The importance of such a course on the future commercial relations of England with China is sufficiently apparent. The danger lies in delay. The former has now a strong hold on the foreign trade of China; but, when the interior is thrown open, there will be an enormous development in every branch of commerce. Foreign banks and trading-houses will become as much a feature of the inland as of the seaboard towns, and the English will have to strain every nerve to maintain their old lead, or the French and the Germans will be before them in the race.

SCIENCE-TEACHING IN ENGLAND.

MR. J. H. GLADSTONE, in an article in *Nature* of May 2, on the new code of the Education Department,¹ which was then before the House of Commons, says that never, since the famous proposals of Mr. Mundella, has there been so much stir among those interested in primary instruction as at the present moment. The reason is not far to seek. For some years a royal commission has been sitting and taking evidence, and it has produced several bulky Blue Books during the course of the past year. It was known that the commission was divided into a majority and minority who were strongly opposed to one another on certain questions of policy. This has found expression in lengthy reports and contradictory recommendations; but, to the satisfaction, if not to the surprise, of educationists, it is found that on purely educational matters there is an almost perfect unanimity between the two sections. It was therefore a matter of deep interest to see how, and to what extent, these recommendations, signed by every member of the commission, would be embodied in the proposed code of 1889.

There are several alterations in this code which are almost universally allowed to be improvements; but it is conceived in a spirit of compromise, and perhaps no party is entirely satisfied with it. The only point to be considered is the aspect of the code towards the teaching of natural science. It may be convenient to group Mr. Gladstone's observations under different headings.

I. The direct changes proposed in the teaching of science. These are almost confined to one or two modifications in the geographical schedule, and to a provision that "scholars of any public elementary school may attend science classes held at any place approved by the inspectors." This may be very useful in towns, especially as it will admit of the formation of central laboratories or workrooms similar to the present cookery centres.

II. The proposed changes which will tend to facilitate the teaching of science. There are four subjects of instruction which are termed "class-subjects," — English (including grammar, composition, and repetition of poetry), geography, elementary science (a progressive course of object-lessons), and history, — together with needle-work for girls. Only two of these class-subjects can be taken for examination, and, under the old code, English must necessarily be one of those chosen. The consequence of this is, that elementary science has never got a footing in the schools in England; for, even where two class-subjects are taken, they are nearly always English and geography, or English and needle-work. The supremacy of English is now to be put an end to, so that any teacher may now take elementary science, if he or she should prefer it, and earn a grant.

The enormous waste of time and patience in making little children, even in infant-schools, learn the spelling of common words, is to be reduced. The inspector is to give no dictation exercises to boys and girls under the second standard. This will give more time for object-lessons and other valuable modes of instruction. Some relaxation of the literary requirements are also made in the case of evening-schools.

The present system of payment by results is to be so modified that the cramming in the three R's will not be so profitable, and there will be more chance for intelligent teaching. One of the matters also to be taken into account by the inspector, in assessing a school, is the provision of apparatus, though this need not necessarily have any thing to do with what scientific men would call by that name.

These proposed changes are in the right direction, but the value of many of them will largely depend upon how they are understood. There is a singular want of clearness in some of the clauses. The annual instructions to inspectors have not yet been drawn up, and indeed it is very improbable that they will make their appearance until after the code has become law. It is quite possible to take away with one hand what is given with the other. The present agitation is therefore of great importance not merely in getting modifications of the code when discussed in Parliament, but in inducing the Education Department to give their inspectors such instructions as shall secure that the greater liberty of teaching

¹ Code of Regulations, with Schedules, by the Right Honorable the Lords of the Privy Council on Education (London, Eyre & Spottiswoode).

should be a reality; that the ominous word "repetition," introduced into one or two paragraphs, may not become "English" in disguise; and that the spelling of the second standard should not involve a laborious preparation of the younger children.

III. These alterations bearing on the teaching of science fall far short of what the royal commissioners unanimously recommend. The report of the majority states that "some elementary instruction in science is only second in importance to the three elementary subjects," — namely, reading, writing, and arithmetic, — and it places among subjects regarded as essential, "geography (especially of the British Empire); lessons on common objects in the lower standards leading up to a knowledge of elementary science in the higher standards." It adds, "that geography, if properly taught, is a branch of elementary science, which should not be separated from the other branches, and might well be taught along with the object-lessons, in accordance with the recommendations of the Royal Commission on Technical Instruction; that the curriculum in the ordinary elementary schools might often include not only instruction in the elementary principles of science, but also, in certain standards, elementary manual instruction in the use of tools, and in higher schools and evening-schools this work might be carried still further; that, in making future appointments to the office of inspector, it would be desirable, in regard to a larger proportion of them than at present, to give special weight to the possession of an adequate knowledge of natural science." The members of the minority express themselves, if possible, more strongly, and make such additional remarks as, "We are of opinion, that, after the children have left the infant-school, transitional methods should be adopted, which will develop their activity and train their powers by drawing in all cases, and by such other means as, for instance, modelling, or the collection and mounting of botanical specimens. . . . If science is to be well taught, care should be taken, that, where the ordinary teachers are not qualified, specially trained teachers should be employed." In respect to technical schools they say, "These schools, which should be the crown and development of elementary education, should be in touch and close sympathy through their management with our elementary school system."

IV. The proposals of the new code also fall far short of what the principal school boards are attempting. Spirited efforts are made in Birmingham, Manchester, Sheffield, Brighton, and other provincial towns, in establishing higher elementary schools with useful scientific teaching. The London Board determined from the commencement that object-lessons leading up to science subjects should be given in all its schools. It has repeatedly contended for the official recognition of such lessons; and it has lately sent a memorial to the Education Department, asking that the regulation at present in force in the infant-schools, that, in assessing the grant, regard should be had "to the provision made for simple lessons on objects and on the phenomena of nature and of common life," should be extended to the boys' and girls' departments.

The reforms decided upon by the London Board last year, with the view of making the teaching more experimental and practical, and not so much a matter of book-learning as a development of intelligence and skill, are being gradually put into operation.

It has also for some years carried on a few classes for manual instruction in the use of tools with good success, but its efforts in that direction have been nearly paralyzed by the disfavor of the legislature. This seems a necessary step towards the technical education which is now loudly called for; but in the new code we look in vain for a word of encouragement.

Some of the larger boards have carefully provided good instruction in natural history, and in the fundamental principles underlying mechanical, physical, and chemical science, for their pupil teachers, though that does not appear upon the government schedule.

V. What is wanted is a far more liberal recognition of the claims of science in elementary education. At present, object-lessons or certain sciences are, no doubt, recognized by the code; but it is merely as an additional subject of instruction not comparable with the literary subjects which are considered essential, and which occupy the great bulk of the scholars' time. The knowledge of nature is, in fact, totally neglected in hundreds or thousands of

elementary schools, especially in country districts, where it would appear to be even more important than in towns. A boys' or girls' school can obtain the highest credit in the inspector's report, and the highest possible grant of money, without its scholars having ever heard of animal or plant, or of those materials of the world, or of those natural forces, with which the scholars will have to deal all through their lives; and, what is perhaps still more anomalous, those pupil-teachers who are possibly expected to give object-lessons in their schools are never examined in natural history by the department, and may gain a high place in their examinations without the least knowledge of any kind of natural science.

It seems most desirable that every little child who enters school should be led to observe and inquire; its curiosity and activity should be encouraged and directed; only when its senses have been made acquainted with things should it be introduced to the words by which they are called, first orally, then in writing or print. It should proceed from the concrete to the abstract. The works of the Creator are as worthy to be studied as the words of men, and should hold as high a place in any school curriculum.

The reply of the department to such requests as these will probably be, "We cannot assume that the teachers are capable of teaching, or the inspectors of examining science." No doubt there is that difficulty. But many of them are capable, and they are all presumably intelligent men, who would easily learn what might be required of them. Special teachers of science also exist, and special examiners might be appointed. It may not be possible to insist on all these reforms at once, but at least encouragement should be held out to them, instead of the disappointing uncertainties of the code now before Parliament.

HEALTH MATTERS.

Tuberculosis Contagion.

DR. VON DUHRING reports to the *British Medical Journal* a case of tuberculosis which was contracted by wearing a pair of earrings. The patient, a girl of fourteen years, removed the earrings from the ear of a young girl who died of consumption, and wore them in her own ears. Soon after, an ulcer formed in the left ear, the discharge from which, when examined, was found to contain tubercle bacilli, and a gland in the neck also enlarged and ulcerated. The patient developed pulmonary consumption, and at the date of the report was sinking rapidly.

This case is one of great interest as showing another channel by which the bacilli of tuberculosis may enter the system. The inquiry will naturally suggest itself, whether this patient was not already phthisical at the time she began to wear the earrings, and the development of the disease at that time a mere coincidence. This would seem the more probable from the age of the patient, which was fourteen years. Then, too, the report states that these two girls were intimate friends, so that the seed may have been sown during their lifetime. Some years ago either of these explanations would, to most minds, have been sufficient; but, through the researches of Koch, an additional means of determining the question has been made available. This is the detection of the bacilli themselves. The report states that this was done in the case mentioned; and, as the methods are simple and decisive, there is no reason to doubt the accuracy of the report. The enlargement of the gland in the neck is additional evidence that the earrings were the source of the infection. It would be interesting to know whether the ears of the first patient were ulcerated or not.

ELECTRICAL NEWS.

ELECTRICAL COURSE AT COLUMBIA COLLEGE.—In view of the prodigious strides which electricity is now making, it is but natural that the necessity for the establishment of a means whereby its thorough and systematic study can be undertaken should have engaged the attention of educational bodies in this country. Columbia College, which has always occupied a prominent position in science, has now established a course of electrical engineering. As its professors, it has secured the services of two men of

excellent repute in electrical and mathematical circles. Mr. Francis B. Crocker, who assumes the instructorship, is no stranger to many of our readers. As one of the inventors of the C. & C. motor, his name has for some time been conspicuously before the public; and his papers read before the American Institute of Electrical Engineers (among which may be specially mentioned that on "Chemical Generators of Electricity," last year) and other scientific bodies have never failed to meet with a welcome. Mr. Crocker is regarded as a rising man in electrical circles; and in this view it is significant that he was, a few weeks ago, elected to the presidency of the New York Electrical Society, which is the oldest organization of its kind in the country. Mr. Michael Pupin is the assistant instructor. From Mr. Pupin's past work and present reputation, great things are expected of him, and he brings to his new sphere of action the additional prestige of having studied under Helmholtz in Berlin.

NOTES AND NEWS.

DURING the past year the director of the Michigan Weather Service has had compiled the average monthly rainfall for each section of that State, and has had the figures published in the monthly report. Believing that the information thus compiled could be better shown by being charted, the director made a chart of the State, showing the average monthly rainfall for each month and for the year. These charts were made up from the observations of thirteen years, and about four thousand reports were examined and proved, to obtain the data. There were also made the charts of the monthly and annual rainfall for the past year which are to accompany the normal charts. These charts will be of great value to the people of Michigan, as the rainfall can be readily compared with the normal, and thus ascertain in each locality whether the rainfall has been the average or not.

— Professor Rosenthal of Erlangen, at a meeting of the Berlin Physiological Society, March 27, gave an account of calorimetric experiments with which he had been busied for the last few years. He employed in these, says *Nature*, an air-calorimeter of special construction. It consisted of a copper vessel, of easy ventilation, in which the animal was placed; this was surrounded by an airtight envelope, filled with air and constituting the reservoir of an air-thermometer; external to this was a covering to shield the whole apparatus from any changes in the temperature of the surrounding atmosphere. When the animal gives up to the envelope of air, per unit of time, exactly the same amount of heat as the whole apparatus radiates into the surroundings, the temperature of the air in the envelope remains constant, as also its pressure: hence the heat produced and given off by the animal during any known time could be measured by means of a manometer. Notwithstanding that the dog used in the experiments was fed in exactly the same way at each meal, the quantities of heat produced varied very largely, and any considerable uniformity is only obtained by taking the mean of a long series of observations. Up to about the third hour after the meal, the heat-production diminishes, then rises rapidly to a maximum; and from this point, at about the eighth hour, it begins to fall again slowly, and with irregularities, until the next meal. Over the whole twenty-four hours the heat-production is more uniform during the second period of twelve hours than in the first; about 20 per cent more heat is produced during the first than during the second half of the whole day. When an excess of food was given, the heat produced was always less than that calculated out from the oxidation of the food itself; but, with a uniformly constant diet, the mean value of the heat produced corresponded to the heat calculated for the oxidation of the food. The amount of carbonic-acid gas given off by the animal was found to correspond to the heat given off during the same period only in cases where prolonged intervals of time were taken into account. When the surrounding temperature varied between 5° and 25° C., all other conditions remaining the same, a minimum production of heat was observed at 15° C.: from this point it increased uniformly in both directions, not only when the temperature fell to 5° C., but also when it rose to 25° C. Professor Schweigger demonstrated several pieces of apparatus, which, by the use of small incandescent electric lamps, could take the place of the ophthalmoscope, and even

render a binocular examination possible. They also made the measurement of refraction in the eye both simple and exact.

— We learn from *Nature* that the extraordinary meeting of the Société Géologique de France, which will be held this year in Paris, beginning on Aug. 18, promises to be one of great interest. During the week devoted to the meeting, the collections in Paris will be visited, and there will be a series of excursions to places of interest within easy reach of that city. In the week following the meeting, excursions will be made to more distant localities; among others to the Auvergne and Brittany, — that to the former district under the guidance of M. Michel-Lévy, and that to Brittany conducted by M. C. Barrois. Arrangements will be made with the railway authorities for a reduction of fifty per cent upon the fares; but, in order to secure this advantage, the names of persons intending to attend must be sent to the secretaries of the society before July 1. British geologists, and especially fellows of the Geological Society of London, are cordially invited to be present.

— Professor W. A. Henry, writing in *Agricultural Science* of some weeds that are becoming troublesome in Wisconsin, says, "On the great plateau along the eastern flank of the Rocky Mountains grows *Solanum rostratum*, a homely, harmless sort of plant. The naturalist knows it to be the original food-plant of the Colorado potato-beetle (*Doryphora 10-lineata*). In the year 1872 or thereabouts the beetle, coming across the uncultivated strip of eastern Colorado and western Kansas, found a new food-plant in the common cultivated potato, and spread with marvellous rapidity over the country. *Solanum rostratum* also comes into the fields to conquer, and has spread on cultivated lands in Texas and Missouri, where, with greatly increased size, it proves a troublesome weed. Last summer Mr. L. H. Pammel, one of our agricultural graduates, now professor of botany in Iowa Agricultural College, found this plant growing at Watertown, in this State. It is following up the potato-beetle. Will it spread over as large an area as its old acquaintance?"

— The annual congress of the German Pomological Society will be held this year at Stuttgart, between the 22d and the 30th of September.

— In 1887 a spot-disease was observed on cucumbers near Geneva, N.Y., which almost ruined the crop. Professor Arthur, says *Garden and Forest*, pronounces it a parasitic fungus similar to one which has been disfiguring peaches in Indiana, detracting from their beauty and hindering their growth. The cucumber-spot did not appear at Geneva in 1888, although it seems an aggressive fungus. It has been named *Cladospodium cucumerinum*. The fungus on peaches has only been recorded before as occurring in southern Austria, where it was named *C. carpophilum*. No remedies for either disease have yet been tried so far as known, but both of them threaten to become dangerous pests.

— A writer in the London *St. James Gazette* objects strongly to the use of footnotes in books, and particularly criticises Mr. Bryce's recent work on this account. He says, "Except for the purpose of relieving the text of references, the footnote has no proper place in any book that deserves to be called a book. It is at best a kind of purgatory, to which an author consigns such remarks as he thinks unworthy of admitting to full honors, and yet has not the courage to cast out altogether. But there is hardly a page of Mr. Bryce's book without footnotes, and hardly a footnote which might not well have been incorporated in the text. Often, indeed, the footnote contains the very 'plum' of the page."

— According to a report lately issued by the Russian Department of Indirect Taxation, there were, in 1887, 2,775 distilleries in Russia, chiefly engaged in producing spirits from fruit. Compared with the preceding year, the number of these distilleries increased by 483; that is, about 21 per cent. This branch of industry is principally concentrated in the Caucasus, where it is rapidly becoming extended. The province of Elizabethpol takes the first place with 1,265 distilleries, then follows Tiflis with 491, Baku with 465, Erivan with 218, and the territories of Koutais and Daghestan with 108. Among the 2,775 distilleries in question, the industrial establishments, properly so called, amount to the number of 260. The product of the distilleries amounted in 1887 to

39,924,903 degrees of alcohol, which yielded to the treasury a sum of 924,805 roubles in excise and other duties.

— By order of the French minister of public instruction, the International Congress of Elementary Education will be held at Paris from Aug. 11 to Aug. 18, on the occasion of the Universal Exhibition. The following are the chief questions for discussion: 1. Under what form and to what extent can professional (agricultural, industrial, commercial) instruction be given in the elementary schools of the lower and higher grades and in training-colleges? 2. How far should women be employed in elementary education as teachers, heads of schools, and inspectresses? 3. What are the functions and the organizations of the practising schools attached to training-colleges and institutions of a like character?

— The students of the ancient University of Genoa, says *The Educational Times*, must be singularly unlike "our young barbarians all at play" on the banks of the Isis and Cam. The Italian students actually desire a competent professor of mathematics, vigorously protest against the fitness of the existing professor, and in general meeting assembled came to the conclusion of demanding by telegraph from the minister of education the appointment of a new professor. In our ancient universities, the honor students find it a serious waste of time to attend college lectures, and so they desert the lecture-hall for the rooms of their private tutor. The ordinary pass student is also quite indifferent as to the quality of his lectures. He also, like the honor student, seeks the aid of the private "coach" to pull him through his examinations. To think of them in open meeting discussing the proper filling of a professorial chair is simply impossible. The Genoese students are of a very different temper. The education minister taking no notice of their singular demand, the whole body of students joined the mathematical men in a general strike, and declined to attend any lectures. Thus the university is closed until this odd dispute is composed.

— In 1887 the population of Bulgaria amounted to 3,154,375, or 31 inhabitants to the square kilometre. The population of the principal communes was distributed as follows: Philippopolis, 33,412; Sofia, 30,428; Rustchuk, 27,198; Varna, 25,256; Shumla, 23,161; Slivno, 20,893; Zagora, 16,039; Tatar Bazardjik, 15,659; Vidine, 14,772; Plevna, 14,307; Sistov, 12,482; Silistria, 11,414; Tirnova, 11,314; and Kustendjs, 10,689 inhabitants. As regards nationalities, the population of 1887 was composed as follows: Bulgarians, 2,326,250; Russians, 1,069; Servians, 2,142; Turks, 607,319; Greeks, 58,338; Jews, 23,546; Gypsies, 60,291; Germans, 2,245; French, 544; and 80,074 persons belonging to other nationalities.

— The University of Munich has been celebrating the ninety-ninth birthday of its famous professor, Dr. Ignatius Döllinger. For sixty-three years Dr. Döllinger has filled the chairs of ecclesiastical history and canon law. As a politician in the Bavarian parliament, and as leader of the Catholic party in the German parliament at Frankfurt, he has played a conspicuous part.

— Floating exhibitions seem to have taken, at least so far as Germany is concerned. The German Export Company has decided, says *London Engineering*, to apply the sum of £250,000 (5,000,000 marks) to the building, equipment, and working of a very large steamer, which is to serve as a floating exhibition. The vessel in question will be called "Kaiser Wilhelm," and the principal dimensions are as follows: length, 564 feet; breadth, 66 feet; depth, 46 feet; so the question is not of a small craft. The steamer is to have four engines, entirely independent of each other, and four propellers. She is to be fitted in exceptionally good style. The expenses for a two-years' tour are calculated at £157,000, while the takings for hire of room and profits on sale are expected to reach £363,000, leaving the very handsome profit of more than £200,000. The steamer will, according to the present arrangements, be ready to start in the spring of next year. A previous undertaking of a similar nature, the steamer "Gottorp," despatched from Hamburg, is understood to have given a satisfactory result. Not only are German goods being shown in many different parts of the world, but the staff accompanying the steamer has ample opportunities for studying in each place the various local and special requirements,

and to see to what extent and in what manner the different warts are being supplied, either by home or by other foreign makers.

—Several friends of the late Dr. F. A. Paley, the eminent classical scholar, have purchased his classical library, and presented it to Cavendish College, Cambridge, England.

—We have given a list of many of the congresses and conferences to be held during the Paris Exhibition; but recently an official circular has been issued, giving detailed particulars. Further information concerning these congresses can be obtained by applying to their respective presidents, whose names and addresses are given: accidents to workmen (Sept. 9-14), M. Linder, 38 Rue de Luxembourg, Paris; advanced teaching (Aug. 5-10), M. Gréard, The Sorbonne, Paris; aeronautics (July 31 to Aug. 3), M. Janssen, Observatoire de Meudon, Seine-et-Oise; agriculture (July 3-31), M. Méline, Palais Bourbon, Paris; alcoholism (July 29-31), M. Bergeron, 157 Boulevard Haussmann, Paris; applied mechanics (Sept. 16-21), M. Philips, 17 Rue des Marignan, Paris; architecture (June 19-22), M. Bailly, 19 Boulevard Bonne-Nouvelle, Paris; artistic proprietary rights (July 25-31), M. Meissonnier, 131 Boulevard Malesherbes, Paris; assistance publique (July 28 to Aug. 4), Dr. Roussel, 64 Rue des Mathurins, Paris; baking (June 28 to July 2), M. Cornet, 34 Rue de Rochechouart, Paris; bibliography of mathematical science (July 16-26), M. Poincaré, 63 Rue Claude Bernard, Paris; care of the blind (Aug. 5-8), M. Marten, 56 Boulevard des Invalides, Paris; celestial photography (no date); cheap dwellings (June 26-28), M. Siegfried, 6 Rond-Point de Champs Elysées, Paris; chemistry (July 29 to Aug. 3); chronometry (Sept. 2-9), M. de Jonquières, 2 Avenue Bugeaud, Paris; colonies, M. Barbey, 22 Rue du Regard, Paris; commerce and industry (Sept. 22-28), M. Poirier, 105 Rue Lafayette, Paris; co-operative stores (Sept. 8-12), M. Clavel, 2 Rue de Bourgogne; criminal anthropology (Aug. 10-17), M. Brouardel, Ecole de Médecine; dentistry (Sept. 1-7), Dr. David, 180 Boulevard St. Germain; dermatology and syphilography (Aug. 5-10), Dr. Hardy, 5 Boulevard Malesherbes, Paris; electricity (Aug. 24-31), M. Mascart, 176 Rue de l'Université, Paris; ethnography, M. Oppert, 2 Rue de Sfax, Paris; female work (no date); fire departments (Aug. 27 and 28), M. Wolff, 18 Avenue Bosquet, Paris; geography (Aug. 6-12), M. de Bizemont, 184 Boulevard St. Germain, Paris; homœopathy (Aug. 21-23), Dr. L. Simon, 5 Rue de la tour des Dames, Paris; horticulture (Aug. 16-21), M. Hardy, 4 Rue du Potager, Versailles; hydrology and climatology (Oct. 3-10), M. Renon, St. Maur, Seine; industrial proprietary rights (Aug. 3), M. Tesserenc de Bort, 82 Avenue Marceau, Paris; legal medical science, Dr. Brouardel, Ecole de Médecine, Paris; literary societies (June 17-27), M. J. Simon, 10 Place de la Madelaine, Paris; marine work (Oct. 7), M. Bernard, 43 Avenue du Trocadere, Paris; mental medical science (Aug. 5-10), Dr. Falret, 114 Rue du Bac, Paris; meteorology (Sept. 19-25), M. Renon, Observatory de St. Maur, Seine; methods of construction (Sept. 9-14), M. Eiffel, 60 Rue Prony, Paris; mines and metallurgy (Sept. 2-11), M. Castel, 144 Boulevard Raspail, Paris; money (Sept. 11-14), M. Magnin, The Bank, Paris; otology and laryngology (Sept. 16-21), Dr. Duplay, 2 Rue de Penthièvre, Paris; participation in profits (July 16-19), M. Robert, 15 Rue de la Banque, Paris; peace, M. Passy, 8 Rue Labordère, Neuilly-sur-Seine; periods of rest from work, M. Léon Say, 21 Rue Fresnel, Paris; pigeon-training (July 31 to Aug. 3), M. Janssen, Observatoire de Meudon, Seine-et-Oise; photography (Aug. 6-17), M. Janssen, Observatoire de Meudon, Seine-et-Oise; physical exercises in education (June 15), M. J. Simon, 10 Place de la Madelaine, Paris; physiological psychology (Aug. 5-10), Dr. Charcot, 117 Boulevard St. Germain, Paris; popular traditions, M. Ploix, Quai Malaquais, Paris; prehistoric anthropology and archaeology (Aug. 19-26), M. de Quatrefages, 36 Rue Geoffroy St. Hilaire, Paris; primary education (Aug. 11-19), M. Gréard, The Sorbonne, Paris; protection of monuments (June 24-29), M. C. Garnier, 60 Boulevard St. Germain, Paris; saving of life (June 12-15), M. Lisbonne, 3 Rue St. Vincent de Paul, Paris; state aid in emigration (no date); state intervention in labor contracts (July 1-4), M. Donnat, 11 Rue Chardin, Paris; state regulation of the price of food (July 5-10), M. F. Passy, 8 Rue Labordère, Neuilly-sur-Seine; statistics, M. Levasseur, 26 Rue Monsieur-le-Prince,

Paris; stenography (Aug. 4-11), M. Grosselet, Palais-Bourbon, Paris; share companies (Aug. 12-19), M. Larombière, 16 Rue d'Assas, Paris; technical commercial education (July 8-12), M. Gréard, The Sorbonne, Paris; therapeutics (Aug. 1-5), Dr. Moutard-Martin, 136 Boulevard Haussmann, Paris; unification of time, M. Faye, 95 Avenue des Champs Elysées, Paris; utilization of rivers (Sept. 22-27), M. Guillemin, 55 Rue Bellechasse, Paris; veterinary medicine (Sept. 19-24), M. Chauveau, 10 Rue Jules Janin, Paris; workmen's clubs (July 11-13); zoölogy (Aug. 5), M. Milne-Edwards, 57 Rue Cuvier, Paris.

—The "Report of the General Board of Studies at Cambridge" (England), while curtailing the demands of the special boards, estimates the additional expenditure imperatively required, either at once or within a very few years, at a high figure. Under the head of "Annual Expenditure" come (1) increase in the salaries of lecturers, demonstrators, and assistants, at the least £1,000; (2) new chairs or lectureships of ancient history, Roman law, English paleography, general jurisprudence, and physiology, for which £1,500 seems a very modest allowance; (3) superannuation pensions for teachers and lecturers, say £1,000. Besides this, a capital sum must shortly be raised of £45,000 for new buildings and plant. This is apportioned between anatomy and physiology (£15,000), geology (£7,500), history (£3,000), library (£3,000), Botanic Gardens (£2,200), and the purchase of the Perse School (£12,500). The last item has already been agreed to by the Senate, and it is hoped that the plans which have been prepared for buildings to be erected on the purchased site—an anatomical museum and physiological laboratory—will be passed before the long vacation. The Medical School at Cambridge has grown within a generation from a few scattered students, mostly Caius men, to over four hundred.

—The latest number of the "Johns Hopkins University Studies in Historical and Political Science" is a pamphlet on "English Culture in Virginia," by William P. Trent. It is really an account of the foundation of the University of Virginia, and especially of the labors undergone in obtaining the earliest professors, most of whom had to be brought over from England. The information given in the pamphlet is derived in the main from the letters of a man named Gilmer, who was sent to England by the university authorities to engage the professors. The work can hardly be said to have any but a local interest, and we confess to have found Gilmer's numerous letters rather dry reading. If the University of Virginia was like those of Oxford and Berlin, its early history would have more general importance; but, as it is, a hundred and forty pages about the hiring of a few professors is rather too much. However, the work will doubtless be interesting to Virginians, and especially to graduates of the university.

—A parliamentary return dealing with the subject of railway collisions during 1888 has recently been issued. It shows that during the past year accidents to trains and rolling stock in Great Britain had caused the death of 11 passengers and 7 servants, compared with 25 passengers and 8 servants the year before; and the injury to 594 passengers and 93 servants, compared with 538 passengers and 109 servants in 1887. There were 101 collisions reported, 53 of passenger-trains leaving the rails, 20 of trains running into stations and sidings at too high a speed, 131 cases of trains running over cattle, and 57 of trains running through gates at level crossings. There were six fires in trains, and three fires at stations. Besides the casualties named above, 96 passengers and 389 servants of companies were killed, and 814 passengers and 2,100 servants injured from other causes. Fifty-three persons were killed and 214 injured through passing over railways at level crossings; 295 trespassers, including suicides, were killed, and 114 injured; and 54 were killed and 84 injured who are not classified. The total was 905 persons killed (a decrease of 14 in number) and 3,826 injured (an increase of 236 compared with 1887). This total is still further increased to 977 killed and 8,807 injured by other accidents, such as those occurring by falling down steps, on and off platforms, from the kicks of horses, and other causes. During the year, 24 horses, 3 ponies, 47 beasts and cows, 73 sheep, 2 donkeys, 4 hounds, 1 goat, and 1 dog were run over and killed.

SCIENCE:

A WEEKLY NEWSPAPER OF ALL THE ARTS AND SCIENCES.

PUBLISHED BY

N. D. C. HODGES,

47 LAFAYETTE PLACE, NEW YORK.

SUBSCRIPTIONS.—United States and Canada.....	\$3.50 a year.
Great Britain and Europe.....	4.50 a year.
Science Club-rates for the United States and Canada (in one remittance):	
1 subscription 1 year	\$ 3.50
2 " 1 year.....	6.00
3 " 1 year.....	8.00
4 " 1 year.....	10.00

Communications will be welcomed from any quarter. Rejected manuscripts will be returned to the authors only when the requisite amount of postage accompanies the manuscript. Whatever is intended for insertion must be authenticated by the name and address of the writer; not necessarily for publication, but as a guaranty of good faith. We do not hold ourselves responsible for any view or opinions expressed in the communications of our correspondents.

VOL. XIII. NEW YORK, MAY 17, 1889. No. 328.

CONTENTS:

AMATEUR PHOTOGRAPHY AND ITS POSSIBILITIES <i>Laura M. Marquand</i> 371	SOAPING GEYSERS..... 382
IMPROVEMENTS IN THE BENTLEY- KNIGHT ELECTRIC RAILWAY SYS- TEM..... 373	THE EAST GREENLANDERS..... 384
RAILWAYS IN CHINA..... 375	THIRD ANNUAL REPORT OF THE DAIRY COMMISSIONER OF NEW JERSEY..... 386
SCIENCE-TEACHING IN ENGLAND..... 378	GOULD'S ORNITHOLOGICAL WORKS... 387
HEALTH MATTERS.	BOOK-REVIEWS.
Tuberculosis Contagion..... 379	Hints for Teachers of Physiology.. 388
ELECTRICAL NEWS.	The Leading Facts of French His- tory..... 388
Electrical Course at Columbia Col- lege..... 379	AMONG THE PUBLISHERS..... 389
NOTES AND NEWS..... 379	LETTERS TO THE EDITOR.
EDITORIAL..... 382	The Ether and the Earth's Atmos- phere <i>Geo. Fras. Fitz Gerald</i> 390

THE OPPONENTS OF VACCINATION in England have of late been more active than ever; and, as a result of their activity, a royal commissioner has been appointed, whose duty it shall be to make a full investigation of the whole subject, and submit a report thereon. Friends of vaccination should welcome such an inquiry, as the method stands upon such a firm foundation of facts as to be able to stand the most searching examination. If it has not accomplished all that is claimed for it, the failure is due to insufficient or inefficient performance of the operation; and the sooner such abuse of it is made public, the better. It is a rather remarkable coincidence that just at this time events should transpire at Sheffield, England, which show the value of vaccination. Small-pox has recently been very prevalent in that city. In a population of about 320,000 there have been 6,088 cases of the disease, of which number 590 proved fatal. Dr. Barry, who has made a report to the Local Government Board, finds that the attack-rate of the vaccinated children under ten was 5 in a thousand; of the unvaccinated of the same age, 101 in a thousand. The death-rates for the same classes were respectively .09 and 44. In every hundred-thousand of those twice vaccinated, there were eight deaths; once vaccinated, 100 deaths; and unvaccinated, 5,100 deaths.

SOAPING GEYSERS.¹

AT the Buffalo meeting, October, 1888, Dr. Raymond presented a paper entitled "Soaping Geysers," in which he called attention to the use of soap by tourists to cause eruptions of several of the well-known geysers in the Yellowstone Park. Incorporated in this paper appears a communication received from me, written from camp in the park, in reply to some inquiries on the subject. The letter discussed somewhat briefly the means employed by visitors to the park to hasten the eruptions from hot-springs and reservoirs of hot water, which remain dormant for days, or even weeks or months, at a temperature near the boiling-point, without any display of geyser-action. As the paper has called forth considerable comment, I desire to elucidate one or two points in relation to the temperature of the springs, and to answer some inquiries about the composition of the thermal waters.

In the summer of 1885, a Chinaman, employed as a laundryman for the accommodation of the tourists at the Upper Geyser Basin, accidentally discovered, much to his amazement, that soap thrown into the spring from which he was accustomed to draw his supply of water produced an eruption in every way similar to the actual workings of a geyser. Tourists with limited time at their command, who had travelled thousands of miles to look upon the wonders of the Yellowstone, soon fell into the way of coaxing the laundryman's spring into action, to partly compensate them for their sore disappointment in witnessing the periodical eruptions of Old Faithful. Successful attempts upon this spring soon led to various endeavors to accelerate action in the dormant and more famous geysers. In a short time, so popular became the desire to stimulate geysers in this way, that the park authorities were compelled to enforce rigidly the rule against throwing objects of any kind into the springs.

In connection with a thorough investigation of the thermal waters of the Yellowstone Park and the phenomena of the geysers, I undertook a number of experiments to ascertain the action of soap upon the waters, and to determine, if possible, those physical conditions of various pools and reservoirs which permitted the hastening of an eruption by the employment of any artificial methods. This investigation, conducted from time to time, as opportunity offered, throughout the field-season of 1885, included experiments upon the geysers and hot-springs of the Upper, Lower, and Norris-Geyser Basins. The results proved, beyond all question, that geyser-action could be forced in a number of ways, but most conveniently by the application of soap. The greater part of the more powerful geysers undergo no perceptible change with a moderate use of soap, although several of them may, under favorable physical conditions, be thrown at times into violent agitation. In most of the experiments, Lewis's concentrated lye, put up in half-pound cans for laundry purposes, was employed. Each package furnished a strong alkali, equivalent to several bars of soap. In this form, alkali is more easily handled than in bars of soap, more especially where it is required to produce a viscous fluid in the larger reservoirs; and, in conducting a series of experiments for comparative purposes, it seemed best, in most instances, to employ the same agent to bring about the desired results.

Old Faithful, the model geyser of the park, exhibits such marked regularity in its workings, that attempts to hasten its action appear futile. The interval between eruptions is about 65 minutes, and rarely exceeds the extreme limits of 57 and 72 minutes. After an eruption of Old Faithful, the reservoir fills up gradually; the water steadily increases in temperature; and conditions favorable to another eruption are produced under circumstances precisely similar to those which have brought about the displays for the past eighteen years, or as far back as we have authentic records. The few experiments which have been made upon Old Faithful are insufficient to afford any results bearing on the question; but it seems probable that soon after the water attains the necessary temperature an eruption takes place.

Of all the powerful geysers in the park, the Bee-Hive offers the most favorable conditions for producing an eruption by artificial means, all the more striking because the natural displays are so futile that they cannot be predicted with any degree of certainty.

¹ Abstract of a paper read before the American Institute of Mining Engineers New York meeting, February, 1889, by Arnold Hague.

Observations extending over a period of several years have failed to determine any established law of periodicity for the Bee-Hive, even for three or four consecutive months; although they indicate that some relationship may exist between its display and those of the famous Giantess. Frequently the Bee-Hive will play several times a day, and then become dormant, showing no signs of activity for weeks and months, although the water may stand above the boiling-point the greater part of the time. The name "Bee-Hive" was suggested by the symmetry of the cone built around the vent. It rises about 4 feet above the sloping mound of geyserite, and in cross-section measures about 3 feet at the top, while at the bottom of the cone the vent is less than 10 inches in width. From the top of this narrow vent it is possible to sink a weight only 17 feet before striking a projecting ledge, which interferes with all examination of the ground below. The constant boiling and bubbling of the water, the irregularity of its action, and the convenient location of the geyser, within an easy walk from the hotel, make attempts to accelerate the eruptions of the Bee-Hive most attractive to tourists.

In most instances such efforts are futile: yet success does so frequently reward the astonished traveller, that, unless the geyser were carefully watched by the authorities, attempts would be made daily throughout the season. If the conditions are favorable to an eruption, it usually takes place in from 10 to 25 minutes after the addition of laundry-soap or lye. It is doubtful if more than two eruptions of the Bee-Hive have ever been produced on the same day by artificial means, although I know of no reason, based upon the structure of the geyser, why more displays might not be obtained; for the reservoir and vent fill up with boiling water very rapidly after each eruption.

Although the Giantess is situated only 400 feet from the Bee-Hive, these two differ in surface and underground structure, and mode of action, as widely as any two of the more prominent geysers of the park. Around the Giantess no cone or mound has formed. The broad basin is only partially rimmed in by a narrow fringe of silicious sinter, rising above and extending out over the deep blue water. At the surface, this basin measures about 15 to 20 feet in width by 20 to 30 feet in length. It has a funnel-shaped caldron, 30 feet in depth, ending in a vertical vent or neck 12 feet deep, through which a sounding-lead may be dropped into a second reservoir, meeting a projecting ledge or obstruction of some kind 61 feet below the surface. After an outburst of the Giantess, the basin, which has been completely emptied of its water, gradually fills again to the top; and for days before another eruption a steady stream of hot water overflows the brim. The intervals between the eruptions of the Giantess vary from twelve to twenty days, and the displays last several hours, being unsurpassed for violence and grandeur by any geyser in the Upper Basin. Artificial means have never been successful in bringing this geyser into action, although for days before an eruption it is an easy matter to cause an agitation of the water by throwing into the basin small pieces of sinter, or to produce a boiling on the surface, lasting several minutes, by simply stirring the water with a stick.

The Giant, one of the most violent of the geysers in the Upper Basin, more closely resembles the Bee-Hive than any other of those along the Firehole River. It has built up a cone 10 feet in height, one side of which has been partly broken down by some eruption more violent than any witnessed at the present day. Through this notched side, steam and broken jets of water are constantly emitted; and on this account but little examination has been made of the underground reservoirs and vents. The Giant is fitful in its action, at times playing with considerable regularity every fourteen days, and at other times lying dormant for nearly a year. I have no positive knowledge that an eruption of the Giant has ever been produced by any other than natural causes. At the time of my experiments, no eruption of the Giant had taken place for several months, although the water was constantly agitated; so much so, that it was quite impossible to examine the vent with any satisfactory results. The only effect produced by the application of lye was additional height to the column of water thrown out, and a decided increase in the thumping and violence of the boiling.

In the Lower Basin, the Fountain has been more carefully studied than the other geysers; and, its action and periodicity of

eruptions having been fairly well ascertained, it afforded the most favorable conditions for observing the action of soap and lye upon the waters. In its general structure, the Fountain belongs to the type of the Giantess, having a funnel-shaped caldron, which, long before an eruption, overflows into an adjoining basin. At the time of my experiments upon the Fountain, the intervals between eruptions lasted about four hours. This interval allowed sufficient time to note any changes which might take place. My own experiments with lye yielded no positive results; although it seemed highly probable that action might be hastened by the application of soap or lye just before the time for an eruption, or when, for some cause, the eruption was overdue. I preferred to make the attempt to bring about an explosion before the usual time, only waiting until the water in the pool had nearly reached the boiling-point. All experiments failed. The previous year, when wishing to produce action for the purpose of photography, I was enabled to accomplish the desired result by vigorously stirring with a slender pole the water near the top of the vent connecting with the lower reservoir. In this instance, it should be said, the usual interval of time between eruptions had long since passed: the geyser was, so far as time was concerned, a half-hour overdue. My opinion now is that the experiments with lye failed because the temperature had scarcely reached the boiling-point.

The Monarch, in the Norris Basin, is quite unlike those already described, and affords evidence of being a much newer geyser. It is formed by two convergent fissures, on the line of a narrow seam in the rhyolite, probably coming together below the surface. The main vent measures about 20 feet in length, and at the surface 3 feet in width. But slight incrustation is found around the vent, the conditions not being very favorable to deposition. In this narrow fissure, the water, which ordinarily stands about 15 feet below the surface, constantly surges and boils, except immediately after an eruption. The intervals between eruptions vary somewhat from year to year; but at the time of these experiments the action was fairly regular, the geyser playing every four hours. I was successful in obtaining an eruption quite equal to the natural displays, which throw a column of water 50 feet into the air. Here at the Monarch there is no surface reservoir; and the narrow fissure, filled with loose blocks of rocks around which the water is in constant agitation, prevents all measurements of depth.

The results of the many experiments, not only upon active geysers, but upon a large number of hot-springs, determine fairly well the essential conditions which render it possible to bring about geyser-action by artificial means. Negative results are frequently as valuable for this inquiry as experiments yielding imposing displays.

Outside of a few exceptional instances, which could not be repeated, and in which action was probably only anticipated by a few minutes in time, geyser eruptions produced by soap or alkali appear to demand two essential requirements,—first, the surface-caldron or reservoir should hold but a small amount of water, exposing only a limited area to the atmosphere; second, the water should stand at or above the boiling-point of water for the altitude of the geyser-basin above sea-level. The principal factor which makes it possible to cause an eruption artificially is, I think, the superheated and unstable condition of the surface-waters. Many of the geysers and hot-springs present the singular phenomena of pools of water heated above the theoretical boiling-point, and, unless disturbed, frequently remain so for many days without exhibiting any signs of ebullition. It may not be easy to describe accurately these superheated waters; but any one who has studied the hot-springs and pools in the park, and carefully noted the temperatures, quickly learns to recognize the peculiar appearance of these basins when heated above the boiling-point. They look as if they were "ready to boil," except that the surface remains placid, only interrupted by numerous steam-bubbles, rising through the water from below, and bursting quietly upon reaching the surface.

Marcel, the French physicist, has specially investigated the phenomena of superheated waters, and has succeeded in attaining a temperature of 105° C. before ebullition. Superheated waters in nature, however, appear to have been scarcely recognized, except during the progress of the work in the Yellowstone Park, in con-

nection with a study of the geysers. The altitudes of the geyser basins above sea-level have been ascertained by long series of barometric readings, continued through several seasons. In conducting a series of observations upon the boiling-points of the thermal waters in the park, Dr. William Hallock, who had charge of this special investigation, determined the theoretical boiling-point by noting the mean daily readings of the mercurial column. The exact boiling-point of a pure surface-water, obtained from a neighboring mountain-stream, and the boiling-point of the thermal waters from the springs, were determined from actual experiments by heating over a fire, employing every possible precaution to avoid sources of error. Surface-waters and deep-seated mineral waters gave the same results, and coincided with the calculated boiling-point at this altitude. Hundreds of observations have been carefully taken where the waters in the active and running springs boiled at temperatures between 198° and 199° F.

As will be shown later in this paper, the thermal waters are solutions of mineral matter too dilute to be affected to any appreciable extent as regards their boiling-point by their dissolved contents. The theoretical boiling-point for the springs and pools in the Upper Geyser Basin may be taken at 92.5° C. (198.5° F.). In many of the large caldrons, where the water remains quiet, a temperature has been recorded of 94° C. (201.2° F.) without the usual phenomena of boiling. This gives a body of superheated water, with a temperature at the surface of 1.5° C. (2.7° F.) above the point necessary to produce explosive action. Thermometers plunged into the basins show slightly varying temperatures, dependent upon their position in the basin. They indicate the existence of numerous currents, and a very unstable equilibrium of the heated waters, which are liable, under slight changes, to burst forth with more or less violence. It is under these conditions that geyser-action can be accelerated by artificial means. If into one of these superheated basins a handful of sinter pebbles be thrown, or the surface of the water be agitated by the rapid motion of a stick or cane, or even by lashing with a rope, a liberation of steam ensues. This is liable to be followed by a long boiling of the water in the pool, which in turn may lead to geyser-action. There is some reason to believe that, at least in one instance, an eruption has been brought about by a violent but temporary gust of wind, which either ruffled the water or disturbed the equilibrium of the pool, and changed momentarily the atmospheric pressure.

In Iceland, travellers have long been accustomed to throw into the geysers turf and soft earth from the bogs and meadows which abound in the neighborhood, the effect produced being much the same as that of sinter pebbles and gravel upon the geysers in the National Park. So well was this understood, that at one time a peasant living near the Iceland locality kept a shovel solely for the accommodation of those visiting the geysers.

In my letter to Dr. Raymond, I mention the curious fact that the laundryman's spring, now known as the Chinaman, in which geyser-action may most easily be produced by artificial means, has never been regarded by the Geological Survey as any thing but a hot-spring; and no one has ever seen it in action without the application of soap, except in one instance, when it was made to play to a height of twenty feet after stirring it vigorously with a pine bough for nearly ten minutes. In our records it is simply known as a spring.

If soap or lye is thrown into most of the small pools, a viscous fluid is formed; and viscosity is, I think, the principal cause in hastening geyser-action. Viscosity must tend to the retention of steam within the basin, and, as in the case of the superheated waters, where the temperature stands at or above the boiling-point, explosive liberation must follow. All alkaline solutions, whether in the laboratory or in nature, exhibit, by reason of this viscosity, a tendency to bump and boil irregularly. Viscosity in these hot-springs must also tend to the formation of bubbles and foam when the steam rises to the surface; and this, in turn, aids to bring about the explosive action, followed by a relief of pressure, and thus to hasten the final and more powerful display. Of course, relief of pressure of the superincumbent waters upon the column of water below the surface basin is essential to all eruptive action. These conditions, it seems to me, are purely physical. Undoubtedly the fatty substances contained in soap aid the alkali in ren-

dering the water viscous. On the other hand, when concentrated lye is used, it acts with greater energy, and furnishes a viscous fluid where soap would yield only surface suds, insufficient to accomplish any phenomenal display.

It is well known that saturated solutions of mineral substances raise the boiling-point very considerably, the temperature having been determined for many of the alkaline salts. In general, I believe the boiling-point increases in proportion to the amount of salt held in solution. Actual tests have shown that the normal boiling-point of silicious waters in the park does not differ appreciably from the ordinary surface-waters; mainly, I suppose, because they are extremely dilute solutions.

The amount of lye required to produce a sufficiently viscous condition of the waters increases but slightly the percentage of mineral matter held in solution.

All the waters of the principal geyser-basins present the closest resemblance in chemical composition, and, for the purposes of this paper, may be considered as identical in their constituents. They have a common origin, being, for the most part, surface-waters which have percolated downward for a sufficient distance to come in contact with large volumes of steam ascending from still greater depths. The mineral contents of the hot-springs are mainly derived from the acid lavas of the park plateau, as the result of the action of the ascending steam and superheated waters upon the rocks below. These thermal waters are essentially silicious alkaline waters, carrying the same constituents in somewhat varying quantities, but always dilute solutions, never exceeding two grams of mineral matter per kilogram of water. When cold, they are potable waters, for the most part slightly alkaline to the taste, and probably wholesome enough, unless taken daily for a long period of time.

Dr. Raymond has made the suggestion that the addition of caustic alkali would possibly precipitate some of the mineral ingredients found in these waters, thereby changing their chemical composition sufficiently to affect the point of ebullition. At the same time he remarks that the geyser-waters are probably too dilute solutions to be much influenced by such additions. Any one who glances at the analyses of the waters of the Bee-Hive, Fountain, and Fearless must see, I think, that they are not only too dilute to undergo any marked change of temperature, but that the mineral constituents consist mainly of the carbonates and chlorides of the alkalies, associated with a relatively large amount of free silica, which would remain unacted upon by caustic alkali. There is nothing in the waters to be thrown down by the addition of alkali, or to permit any chemical combinations to be formed by the addition of a small amount of soap. The desire of tourists to "soap a geyser" during their trip through the park grows annually with the increase of travel; so much so, that there is a steady demand for the toilet-soap of the hotels. If visitors could have their way, the beautiful blue springs and basins of the geysers would be "in the suds" constantly throughout the season. Throwing any thing into the hot-springs is now prohibited by the government authorities. It is certainly detrimental to the preservation of the geysers, and the practice cannot be too strongly condemned by all interested in the National Reservation.

THE EAST GREENLANDERS.

CAPT. HOLM'S expedition to East Greenland was as remarkable on account of its geographical results as in regard to the ethnological observations made among the isolated tribes of the northern parts of the east coast of Greenland. The results of his journey have been published, and form the tenth volume of the "Meddelelser om Grönland." In a recent number we referred to the linguistic and folk-loristic papers. Of no less importance are the general anthropometric and ethnographical results of the expedition.

Dr. Sørensen Nansen has submitted the craniological material and the measurements of Capt. Holm to an elaborate discussion, from which we glean the following facts. The whole population consisted of 548 heads, 245 of whom were males, while 303 were females. The size of the people is below the average, being 1,647 millimetres; while in the southern parts of the coast the average

size is only 1,604 millimetres on the east coast, and 1,547 on the west coast. The people of East Greenland are not as dolichocephalic as those of other regions, the length-width index of men being 76.9; that of women, 75.6. The face is oval, the lower part being comparatively large. The superior facial index is 103.8; the gonio-zygomatic index, 82.3, — two important figures, as they are the highest of all known indices. The form of the nose varies considerably, but is generally narrow and prominent, frequently aquiline.

Capt. Holm's description of the customs of this people is full of interest. His graphic description is made still more useful by a number of excellent lithographic plates, in which implements and works of art are represented.

During winter, the people of this region inhabit stone houses. In each inhabited place there is only one house, in which as many as ten families dwell. The oldest man acts as chief, as he is or has been a good hunter, and has sons who are good hunters. This position of senior chief rests probably upon a tacit acknowledgment of his authority, which is shown by the fact that he receives visitors, and represents all the inhabitants of the house. The ties of consanguinity are considered as imposing the duty of mutual assistance. Marriage, on the other hand, is not considered a binding tie. It is only after she has had children, that the wife's position becomes somewhat more firmly established. The husband is the chief of the family. Next to him are his sons, even when quite young, because they are considered the future hunters, who provide for the wants of their parents in old age. While the parents are alive, the sons live with them, and feed and clothe them.

The natives of this region frequently marry before they are grown up, as soon as a young man is able to provide for his wife. Good hunters have frequently two wives. As one woman cannot prepare all the skins obtained by the hunter, he frequently takes a second wife at the demand of the first. Sometimes his object in taking a second wife is to have two oarsmen for his boat. No instance is known of a man having more than two wives.

After death, the corpse is clothed in the best winter garments. Men are clothed in their kayak jacket. The head is covered with a hood, the limbs are tied up, and the corpse is dragged without any ceremony through the long passage of the house, or, if this is too difficult, it is removed through the window. If one of his ancestors has perished in the kayak, the corpse is thrown into the sea or deposited on the beach, where it is covered by the rising tide. In winter it is thrown through a hole cut through the ice. Sometimes, at least in former times, the dead were buried under bowlders. The principal implements of the dead are deposited by the side of the grave.

The natives have numerous mourning ceremonies, which consist principally in lamentations and in abstaining from certain kinds of food. The name of the deceased is never mentioned. For this reason, if two men have the same name, the survivor must take a new one. If the deceased had the name of an animal or some other object, the word designating this animal must be changed. Thus the language undergoes material changes, as these new words are adopted by the whole population. But the old words frequently re-appear when the dead one has been forgotten.

Man is believed to be composed of three parts, — the body, the soul, and the name. The soul is small, not larger than a finger, and lives in the body of the man. When it falls sick, the man also falls sick; and if it dies, the man also dies. After the death of a man, his soul revives, either in heaven or in the sea. Both lives after death are considered good, but the former is preferable.

The name is as large as a man, and enters the child when, after birth, it is wiped with some water around the mouth, the names of the deceased after whom it is to be called being pronounced at the same time. When a man dies, the name remains near the corpse, in the water or on the land, until a child receives the name of the deceased. Then it enters the child, and there continues to exist. Still-born children are in heaven, where they produce the northern lights.

The Eskimo of East Greenland believe in a great number of spirits, which, however, are visible only to the angekok, the shamans of the Eskimo. The sea-animals are governed by a giant woman, in whose hair hang seals, narwhals, and other animals.

When the angekok is led to her by his guardian spirit, and he combs her hair, the animals come to the coast. Another important spirit is Tornarsuk, who also lives in the sea. He is described as being as tall as a large seal, and partly resembles a seal, partly a man. He swims rapidly through the depths of the sea.

There is an interesting legend which is found all over arctic America. It refers to the Erkilik, the upper part of whom is of human shape, while their feet are those of dogs. It is said that these Erkilik and the Europeans are the descendants of a woman who had married a dog.

These spirits, and the many others of whom the Eskimo tell, are not the subjects of any worship; but, in order to prevent them from doing harm to man, amulets are worn, which are believed to be a means of protection against sickness, and which secure long life to the wearer. Besides this, magic formulas are used in cases of sickness or to avert dangers. These formulas are also used to do harm to one's enemies. They are very ancient, and are transmitted from generation to generation. They are considered particularly effective when applied for the first time by a certain individual, while in course of time they lose in value and power. For this reason they are recited only in cases of imminent danger. They are spoken slowly, and in a low voice. The meaning of the words is entirely unknown.

Every angekok has his Tornarsuk and a being that is intermediate between himself and this Tornarsuk. In order to be a skilful angekok, it is necessary to have command over a great number of spirits. Besides, the angekok must be an expert in jugglery, he must have always a ready answer, and be able to make a diabolical impression upon his audience so as to strongly excite their nerves. The help of the angekok is asked for securing good luck in hunting, to procure favorable winds, and to cure sickness. They are not conversant, however, with the medicinal properties of any plant or mineral, but their operations are confined to treating the soul of the sick person.

It is the belief of the Eskimo that all diseases are due to the soul, which may be hurt or stolen by a sorcerer or by an angekok. It becomes, therefore, the duty of the angekok to find its whereabouts. His guardian spirit informs him of the cause of the disease, and of what has happened to the soul. If it has left the body, the angekok, by the help of his guardian spirit, makes marvellous journeys to recover it.

Besides the angekok, there are real sorcerers, whose principal object it is to do harm to their enemies. They are particularly able to construct the Tupilak, — a fabulous animal, artificially made of bone, skin, and flesh, which is to destroy the enemy of its master. The practices of sorcery of these men are numerous and of varied description; but the greater number are wholly imaginary. They have still other means of doing damage to their enemies; for instance, by using the flesh of a corpse. A man may be a sorcerer without carrying out his art, but then he is liable to fall into fits. In such cases he is slowly starved, and heavy stones are placed on his belly until he dies. This torture is often shortened by throwing the sick one into the sea. The only means of one escaping this treatment is by confessing that he is a sorcerer, and telling all his real and imaginary crimes. It is believed that thus he loses his supernatural powers.

The natives of the east coast of Greenland have an interesting tale stating that Greenland is an island. They say that long ago a man named Uyartek made a journey around the island. In the tale of this voyage, a point is named the end of the land. According to the description, this point is in about 68½° north latitude. Before coming there, a large fiord is said to intersect the coast.

They account for the existence of glaciers in the following way: When the land first made its appearance, there were neither sea nor mountains, but all was an enormous plain. As man was bad, the one in heaven destroyed the earth. Chasms opened, in which man perished. Then the water covered every thing. When land appeared for the second time, it was covered all over with glaciers. Two beings fell from heaven, who repopulated the earth. Since that time the glaciers have continually retreated. There are many places in which traces of their having been once covered by the sea may be seen.

The art of carving is very highly developed. It is a remarkable

fact that in this respect the extreme eastern Eskimo are very much like the inhabitants of Alaska. Among the implements collected by the expedition, are a great number of excellent carvings,—boxes, harpoon-staffs, and other implements, covered all over with carved figures. On all kinds of objects a single ornament is found, representing a seal. Mr. Holm believes that the high development of this art favors the opinion of Dr. H. Rink, who thinks that the East Greenlanders visited the coast coming from the north. He mentions the following facts as favoring this theory: the occurrence of deserted habitations in the northern parts of East Greenland; the undoubted fact that a number of animals reached the east coast coming from the north; and the tale of Uyartek, who travelled all around Greenland. The high development of the art of the East Greenlanders leads him to think that they were in contact with the far-distant Alaskan tribes at a comparatively recent date, while they must have been separated for a long time from the West Greenlanders.

THIRD ANNUAL REPORT OF THE DAIRY COMMISSIONER OF NEW JERSEY.

THE third annual report of the dairy commissioner of New Jersey, being the report for 1888, is full of interesting material. Dr. William K. Newton's long experience in work of this kind renders his reports of great value to all health-officers engaged in discovering the many frauds practised on consumers. Of 623 articles of food analyzed, 303, or 48.64 per cent, were adulterated or below the legal standards. We have not space in which to consider them all in detail, but will select a few of the most important. Of butter and oleomargarine, 68 samples were examined, and 44 of them were found to be adulterated or not standard. Many samples were submitted supposed to be oleomargarine, but they proved to be bad butter. Dr. Newton says that it may be stated as an invariable rule, that if the suspected material is rancid, and has a disagreeable odor, it is inferior butter, and not oleomargarine. The latter may become granular, and have a disagreeable, greasy taste; but it never turns rancid. Of 121 samples of milk, 43 were not as required by law. Adulteration is now practically confined to the large cities. The general milk is excellent. Of 55 samples of American canned goods analyzed, but one was found not up to the standard. During the year, of tomatoes alone, 3,319,437 cans were packed in the United States, 789,363 of them being put up in New Jersey. In speaking of the alleged danger from these goods, Dr. Newton says that it has been his practice for the past few years to investigate all reports of poisoning supposed to be due to the eating of canned articles, but in no instance has he found a well-authenticated case of poisoning. On this subject he says,—

"It is claimed that lead and tin have been found in large quantities in canned vegetables. My investigations have never revealed a single case where lead was in quantities large enough to detect. If that metal is present in these preserved foods, immediate steps should be taken to prevent the sale of articles so contaminated; for it is well known that the constant ingestion of very minute quantities of lead and some of its salts is almost invariably followed by symptoms of poisoning. And these symptoms are well marked, and known to every physician: hence, if there are cases of lead-poisoning due to this cause, a short time only would elapse before they would be placed on record. Lead is a cumulative poison, and is very slowly cast out by the system; but the ingestion of quantities as small as $\frac{1}{2}$ or $\frac{1}{100}$ of a grain, for a time is almost certain to be followed by symptoms of poisoning. I mention these well-known facts for the following reasons: first, if there have been cases of lead-poisoning caused by the use of canned foods contaminated with this metal, the medical profession would have, ere this, published accounts of the cases; second, the contrast between this metal and tin is so marked that the mere mention of the facts will be convincing.

"There is no doubt but that tin is frequently found in the articles preserved in vessels made of that metal. Especially so is this the case with acid vegetables like tomatoes, and the tables given show how often it has been revealed by the analyses just concluded. This being the case, the question is naturally asked, Is this metal poisonous, or are the quantities detected of any importance? Tin is commonly considered, next to iron, one of the most

innocuous of the baser metals. Nearly all of our culinary vessels are made of it, and their use is never followed by any ill results. All the evidence regarding the effects of tin on the system is negative. There are no recorded cases of poisoning, and, in fact, no mention is made in the authoritative works on toxicology of tin as a dangerous metal. The only instances where poisonous properties have been claimed for tin are in the records of cases of adulteration of molasses by a certain salt of that metal. Such cases were tried in the Massachusetts courts, but the evidence was not conclusive. We may, then, accept the facts in this relation, and state, that so far as scientific records now go, and so far as evidence is recorded, the quantity and quality of tin as found in canned foods are not injurious."

Mr. Shippen Wallace, chemist of the Board of Health, says that the fact cannot be too thoroughly impressed on the community, that the present system of canning vegetables is of inestimable value; but the same rules should be followed which are made use of with fresh vegetables in their use; that is to say, if, on opening a can, the contents are spoiled, act as one would with fresh vegetables under similar circumstances,—throw them away. This done, there is no possible danger in their use; but if not, the same risk is run as would be in the use of spoiled fresh vegetables, only to a greater extent.

In examining canned asparagus, a large amount of tin was found, and the interior of the can was invariably blackened. This may come from the acid in the asparagus, or from some ingredients used in the process of canning. From the results of the examination of asparagus packed in tin, it would seem to be demonstrated that this vegetable should be put up in glass only, and that the use of tin should be abandoned. Dr. Newton further says, that, of all cases of sickness caused by eating canned goods, the cause has always been found to have been that the contents were spoiled when opened, or the can had been allowed to remain open for a day or more before the contents were used.

Of six samples of ground coffee examined, 8 were pure and 16 adulterated. The adulterants were roasted and ground peas, beans, wheat, and chicory. The examination of tea showed that while there is no adulteration, there is a large amount of inferior and debased tea used in New Jersey.

Of 415 samples of drugs examined, 231 were found of inferior quality. Of 95 samples of cream-of-tartar, but 46 were up to the standard. Few articles are so commonly debased as this one. In speaking of this, Dr. Newton says,—

"The adulterations detected, in the greater number of debased samples, were clearly intentional, and were not due to lack of care in the methods of manufacture. An excess of tartrate or traces of chloride may well be considered as due to want of skill, or lack of care, in the maker; but the presence of sulphates, phosphates, alum, and flour can be accounted for in one way only, that is, they were added for fraudulent purposes.

"Several unique samples were examined. One, purchased at Beverly, contained no cream-of-tartar, but was a mixture of flour, acid phosphate of lime, and sulphate of lime; another sample of the same kind was sold to one of my agents at Cape May. A sample was sold by a dealer at Pemberton that proved to be a mixture of alum, phosphate of lime, and 64 per cent of cream-of-tartar. Several were obtained in different parts of the State that were adulterated with impure acid phosphate of lime.

"The samples that were equal to the standard were, in at least 90 per cent of the cases, obtained from druggists, but many from this source were badly debased. The impure cream-of-tartar obtained in this State came largely from the Southern and Western sections, and was sold to dealers by agents and jobbers from Philadelphia. There appears to be a certain relation between the fertilizer trade in that city and the bogus cream-of-tartar business, the connection probably being due to the trade in impure phosphates.

"Two suits were instituted against dealers in the very impure article, these being settled on the payment of costs, when the dealer promised to return the adulterated article to the wholesale dealer, and to sell only the pure article. Warning notices were sent to all other dealers detected in selling adulterated cream-of-tartar."

Forty-three samples of medicinal distilled liquors were examined, of which six answered to the tests given in the pharmacopœia and dispensatory, and thirty-seven were inferior. These distilled liquors were all purchased at drug-stores, and the dealer was presumed to know that they were intended for medicinal use. The price paid varied from the rate of four dollars to twenty dollars a gallon, yet this was not indicative of the quality.

The pharmacopœia defines brandy to be "an alcoholic liquid obtained by the distillation of fermented grapes, and at least four years old." It shall contain from 36 to 47 per cent, by weight, of alcohol, shall not contain any fusel-oil, nor shall the residue obtained by evaporation exceed 0.25 per cent. There should be no evidence that sugar or glycerine has been added, and it should contain a slight amount of tannin derived from the casks. None of the samples answered to these tests, and there was no proof that the article was of the proper age.

The difficulty of obtaining pure brandy of a proper age for medicinal use is very great. This is especially true of the imported article; while that made in California is, as a rule, of inferior quality, and not sufficiently aged and bland to be used in cases of illness. The following statement, made in the "United States Consular Reports," November, 1887, p. 333, is interesting in this connection:—

"The term 'brandy' seems to be no longer applied to a spirit produced by the fermentation of grapes, but to a complex mixture, the alcohol of which is derived from grain, potatoes, or, worst of all, the refuse of the beet-root refineries. It would seem to be fairly impossible at present to purchase a pure cognac. As each individual proprietor of a vineyard has become a distiller and compounder, he has acquired the art of imitating any special flavor or vintage of brandy that may be called for. Potato spirits and beet alcohols, the most deleterious and obnoxious of all the varieties of spirits, are sent from Germany into France in vast quantities. They are flavored, colored, and branded or labelled to meet the wishes of American connoisseurs. The mere fact of coming out of bond, or 'straight through the custom-house,' is generally accepted here as sufficient evidence that they are pure and genuine. It is rather unfortunate that physicians themselves frequently strengthen this hallucination in favor of imported spirits by giving the most stringent orders to their patients to procure genuine French cognac, even though it may command tenfold the price of an absolutely pure spirit of domestic production. This imperative command becomes a cruel injustice in the case of poor patients. Under the best of circumstances, what is there to be gained by the use of French brandy in preference to pure domestic spirit?"

And, it may be added to this statement, if alcoholic stimulants are to be prescribed by the physician, let him first ascertain the source of the sample, and acquaint himself with the quality, origin, and ingredients. The alcoholic strength in the samples analyzed varied from 37 to 47 per cent of alcohol by weight. Of the 15 samples of whiskey examined, 3 were equal to the requirements of the pharmacopœia. That authority defines this spirit as follows: "An alcoholic liquid, obtained by the distillation of fermented grain, generally corn, wheat, or rye, and at least two years old." Its alcoholic strength should be between 44 and 50 per cent by weight. It should contain no fusel-oil, not more than 0.25 per cent of residue on evaporation, and traces of tannin from the casks. The object sought by this description is to insure a properly made and aged liquor, and one without irritant or acrid properties.

The same objections to the use of impure or badly made whiskey obtain as were mentioned above, and physicians should not prescribe for use in cases of sickness a stimulant that fails to meet the pharmacopœial tests. The alcoholic strength of the samples examined varied from 34 to 48 per cent of alcohol by weight.

Of 42 samples of laudanum examined, only 8 were up to the standard. Dr. Newton's investigation revealed many important facts concerning the prevalence of the opium habit, and he was surprised to learn the amount of this potent drug, and its tincture, that is sold at country grocery-stores; but that the consumption of this article is great, and increasing, was no surprise when he ascertained how easily the article could be obtained, notwithstanding the State law that bottles containing the tincture should be

labelled, and not disposed of to irresponsible persons. He suggests that some action be taken that will check the sale of opium and its preparations to irresponsible persons, or without an order from a physician.

The report contains, in addition, an exhaustive inquiry into the baking-powders used in the State, which we shall notice at another time, and a list of decisions by the Supreme Court on the oleo-margarine law.

Residents of New Jersey may congratulate themselves on having so capable and watchful an officer as Dr. Newton at the head of this important department, and we regret that the same congratulations cannot be extended to the residents of many other States in the Union.

GOULD'S ORNITHOLOGICAL WORKS.

MESSRS. HENRY SOTHERAN & Co., of London and Manchester, having purchased from the executors of the late naturalist, Mr. John Gould, F.R.S., F.Z.S., the whole stock, lithographic drawings, copyright interests, etc., of his various works on natural history, announce the completion of this grand series of ornithological works by the publication of the twenty-fifth part of "The Birds of New Guinea and the Adjacent Papuan Islands." This series, comprising forty-three volumes, uniformly printed in imperial folio size, is now offered complete for one thousand pounds net.

A short biographical sketch of Mr. Gould appeared in *Nature* some time ago, from which it appears that John Gould was born at Lyme, in Dorsetshire, in 1804, and in early life passed several years under the care of the late Mr. J. T. Aiton, of the Royal Gardens at Windsor. In the year 1827 he went to London, and became taxidermist to the Zoological Society's museum, where he had the good fortune to obtain the intimate friendship of Mr. N. A. Vigors, then one of the leading English naturalists; and through him John Gould received his first opportunity of appearing as an author. So rare were Himalayan birds in those days, that a small collection was thought worthy of description by Mr. Vigors in the "Proceedings of the Zoological Society," and the figuring of these specimens was commenced by Mr. Gould under the title of "A Century of Birds from the Himalayan Mountains." By this time, however, an event had taken place which had an influence on the whole of his later life; viz., his marriage with Miss Coxen, the daughter of Mr. Nicholas Coxen of Kent. Besides her other accomplishments, Mrs. Gould was an admirable draughtswoman, and from her husband's sketches she transferred to stone the figures of the above-named work. Its success was so great that in 1832 the "Birds of Europe" was commenced, and finished in five large folio volumes in 1837; while simultaneously, in 1834, he issued "A Monograph of the Rhamnastidae, or Family of Toucans," and, in 1838, "A Monograph of the Trogonidae, or Family of Trogons." To the last he maintained his love for these birds, and one of his most recently finished works was a second edition of the last-mentioned monograph. It is a curious fact, that, when John Gould proposed to publish his first work, he applied to several of the leading firms in London, and not one of them would undertake to bring it out; so that it was only with reluctance that he began to issue the work on his own account. Besides these larger publications, he had described the birds collected during the voyage of the "Beagle" by his friend Mr. Darwin, and had contributed papers on other subjects to the Zoological Society's publications.

We now come to what is considered the most striking incident in Mr. Gould's life,—one unsurpassed in its effects in the annals of ornithology. Beyond a few scattered descriptions by some of the older authors, and an account of the Australian birds in the museum of the Linnean Society by Messrs. Vigors and Horsfield, the birds of Australasia were very little known at the date mentioned. Accompanied, therefore, by his devoted wife, Mr. Gould proceeded in 1838 to study Australian birds in their own home; and he personally explored Tasmania, the islands in Bass's Straits, South Australia, and New South Wales, travelling four hundred miles into the interior of the latter country. This voyage, specially undertaken for the purpose of obtaining an exact knowledge of Australian birds, must ever be reckoned as a distinct scientific achievement; and the accounts of the habits of some of the more

remarkable species, such as the mound-building megapodes and the bower-birds, were quite triumphs in the way of field ornithology. Nests and eggs were collected, as well as an excellent series of skins, both of mammals and birds; and here Mr. Gould's beautiful method of preparation was especially noticeable. Some of his specimens, skinned more than thirty years ago, are as neat in appearance, and as fresh, as the day they were prepared. Returning in 1840, after two years' absence, he commenced the great work on the "Birds of Australia," which makes seven folio volumes, and occupied seven years in its production, being completed in 1848. One of the features of this work is the great increase in our knowledge of the range and habits of petrels and other seabirds, to which the author paid great attention during his travels, and is by far the most important, from an ornithological point of view, of all Gould's works.

Within a year of Mr. Gould's return from his adventurous voyage, he had the misfortune to lose his wife, and for some time he was completely overwhelmed by his bereavement. His collectors in Australia too, about the same period, lost their lives. One of them, Mr. Gilbert, was killed during Dr. Leichhardt's expedition overland from Moreton Bay to Port Essington; and Mr. Drummond, while collecting in western Australia, was also murdered by natives; and a third collector was killed by the explosion of a gun on one of the islands of Bass's Straits. It speaks volumes, however, for the zeal and energy with which Mr. Gould had prosecuted his researches in the Australian continent, that very few birds (sufficient only to form a supplement in a single folio volume) have been discovered since he left the field of his labors in that quarter of the globe.

Another landmark in the career of this great ornithologist was the publication of his "Monograph of the Trochilidae, or Family of Humming-Birds." These lovely little birds had been for a long time favorites with Mr. Gould, who gradually began to amass that fine collection which has been the admiration of naturalists for so many years. Taking advantage of the great exhibition of 1851, he obtained permission from the Zoological Society to erect, at his own cost, a large building in their gardens in the Regent's Park, where the collection was open to the public at a charge of sixpence per head. A considerable sum was realized by this exhibition, and a large number of subscribers to his monograph were obtained, including nearly all the royal families of Europe. Though sketched by Mr. Gould himself (for even to the last days of his life he executed the designs for all his plates), the majority of the humming-birds were placed on stone by Mr. Richter, who also did the same for Mr. Gould's next work, the "Birds of Asia." This work, though not completed at the time of his death, aged seventy-six, on Feb. 3, 1881, was brought to a satisfactory conclusion by Mr. R. Bowdler Sharpe, F.L.S., F.Z.S., etc., of the British Museum, acting on behalf of Messrs. H. Sotheran & Co., who have since brought his other unfinished works to completion, as hereafter mentioned. It is most valuable on account of the number of plates of species not figured elsewhere. The "Mammals of Australia," produced simultaneously with the last-mentioned work, deserved, in Mr. Gould's own opinion, more credit for its issue than perhaps any work he had done, because it touched upon a branch of zoology of which he never pretended to have any very exact knowledge. So large, however, had been his collections of *Mammalia* during his sojourn in Australia, that some account of them seemed to be demanded, and he therefore published his large folio work; but the pecuniary results were less satisfactory than with any of his ornithological productions. His typical specimens of the Australian *Mammalia* are in the national collection. No sooner were the humming-birds finished than his active brain conceived a new idea, to illustrate becomingly the birds of his native land, and he commenced the publication of the "Birds of Great Britain." Opinions may differ as to the merit of Mr. Gould's other works; volumes less ponderous than the folios which he adopted for the better figuring of the objects of the natural size may take their place with the student; but no work of greater beauty will be produced than that on which John Gould, returning in his later life to his first love, bestowed the fulness of his energy and the acme of his artistic talent. The care bestowed on the plates of this work was remarkable, the aim of the author being to produce a picture

of the birds as they appeared in their natural haunts; and especial pains were bestowed on the young, particularly those of the wading-birds and natatores. In this fine work most of the drawings were developed and placed on stone by Mr. W. Hart, who also executed all the plates of the later works.

In 1865, Mr. Gould republished his letterpress of the big work in an octavo form, under the title of "A Handbook to the Birds of Australia," but with all the additional species inserted in their proper families: these two volumes are therefore of great use to the student. After the completion of his work on "British Birds," Mr. Gould devoted himself to the continuation of the "Birds of Asia" and the supplement to the "Birds of Australia," until, in 1875, he commenced a work on the "Birds of New Guinea," which was to contain also descriptions of any new species that might be discovered in Australia or any part of the Australian region. Of the last-named work, eleven parts had appeared at his death, and it has since been completed by Mr. Bowdler Sharpe. The following works were also left unfinished: "A Monograph of the Pittidæ, or Ant-Thrushes of the Old World" (one part published); and the supplement to the "Monograph of the Humming-Birds," which has also been completed by Mr. Sharpe, with the co-operation of Mr. Osbert Salvin.

The above list enumerates all the works published by Mr. Gould, with the exception of the "Icones Avium" (issued about 1838, and containing supplementary plates to his previous volumes, with descriptions of new species), "A Monograph of the Odontophorinæ, or Partridges of America," "Synopsis of the Birds of Australia," and "A Monograph of the Macropodidæ" (published in 1841-42). In addition to the folio volumes, he was also in the habit of reprinting the introductions to his larger works in an octavo form for presentation to his friends.

BOOK-REVIEWS.

Hints for Teachers of Physiology. (Guides for Science-Teaching, No. XIV.) By H. P. BOWDITCH, M.D. Boston, Heath. 24°.

AT the present time physiology is taught in most of the grammar-schools; and the author has attempted to show how a teacher may supplement text-book instruction by means of simple observations and experiments on living bodies or on organic material, thus imparting to the pupils a knowledge of the foundation on which physiology rests, and at the same time bringing the impressions made on the senses to aid the memory in retaining the facts communicated in a purely didactic way. The reputation of Professor Bowditch as one of the foremost physiologists of America is a guaranty that the advice which he gives is based on scientific principles, and we heartily commend this manual to all teachers of physiology. Even those who are giving instruction to students more advanced than those in grammar-schools will find here many useful hints and suggestions.

The Leading Facts of French History. By D. H. MONTGOMERY. Boston, Ginn. 12°. \$1.25.

THIS work is intended for the use of schools, and is well adapted to its purpose. It treats, as its name implies, of the leading facts only, very few passages being filled with detail; and the story is in the main well told. The author's style is simple and easily understood, and the book is divided into sections with suitable headings for the student's use. Its principal defect is that it is almost exclusively a political history; the general progress of civilization, and the more special histories of literature, science, philosophy, and art, being almost wholly neglected. Mr. Montgomery puts on his titlepage the remark of Guizot, that "there is hardly any great idea, hardly any great principle of civilization, which has not had to pass through France in order to be disseminated;" but, owing to the scanty information furnished about the progress of civilization, this remark receives but slight illustration from this work.

The political history itself, however, is well treated, the really important topics being put in the foreground, while battles and court intrigues are relegated to their proper place. The earliest periods of French history are of course passed over somewhat lightly, but as much is said about them as most students will care for, and particular care is taken to show how the kingdom grew

from a comparatively small district around Paris to its full development. Coming down to later times, the author exhibits pretty clearly the growth of arbitrary power and of the unjust privileges of the nobles, and repeatedly dwells on the misery which these produced among the masses of the people. Thus he prepares the way for an understanding of the Revolution, which of course occupies a considerable share of attention. In this part of his work, however, it seems to us that he dwells rather too much on the horrors that were then enacted, and too little on the benefits that the Revolution ultimately brought. Napoleon is treated with justifiable severity, while at the same time his good deeds are duly acknowledged, and certain incidental benefits of his conquests are pointed out. The present condition of France is regarded as hopeful, and her prosperity as well grounded. Mr. Montgomery's work will be useful not only to students, but also to private readers who wish for a general sketch of French history unencumbered by useless details.

AMONG THE PUBLISHERS.

THE two articles on agnosticism, in *The Popular Science Monthly* for April and May, will be followed by two more in the June number. One of these is by Professor Huxley, in rejoinder to Dr. Wace and the Bishop of Peterborough; the other, by Mr. W. H. Mallock, is entitled "Cowardly Agnosticism," and criticises Professor Huxley's objections to the above phrase, expressed in his first article. "The Production of Beet-Sugar," including the method of growing the plant, and the processes employed in ex-

tracting the sugar, will be described by Mr. A. H. Almy. This account, together with the paper in the *May Monthly*, gives a complete view of an industry which has yielded large profits to the farmers of Germany, and promises to become equally important in this country. Widespread interest has been manifested in the article on "Christian Science," in the April *Popular Science Monthly*, and nowhere more than among the healers themselves. Of the several replies offered by members of this fraternity, the *Monthly* will publish one in the June issue, by Mr. J. F. Bailey, editor of the *Christian Science Journal*, under the title "Is Christian Science a Craze?" An editorial in the same number will clearly state the position of the magazine on this subject. "Glaciers on the Pacific Coast," is the title of an illustrated descriptive article, by Professor G. Frederick Wright, to appear in June.

— The articles on "The Practical Applications of Electricity," which begin in the June *Scientific*, will, it is announced, be as complete a picture of the present position of electricity in the industrial world as the Railway Series is of the great subject of transportation. The men who have been secured to write these articles are acknowledged authorities in the subjects of lighting, telegraphy, medical electricity, etc., including among their number President Morton of Stevens Institute; C. L. Buckingham of the Western Union; A. E. Kennelly, Mr. Edison's chief electrician; Dr. M. Allen Starr; and Professor Brackett of the Princeton Scientific School. W. A. Linn, of the *New York Evening Post*, has written for the number a complete popular account of the origin, growth, and present management of that form of co-operation known as

Publications received at Editor's Office,
April 29-May 4.

CLIMATOLOGY and Meteorology, List of Books and Articles on, in the Library of the Surgeon-General's Office, United States Army. (Extract from the Index Catalogue.) Washington, Government. 17 p. 8°. GUTTENBERG, G. A Course of Mineralogy, for Young People. Second Grade. Erie, Penn., The Author. 44 p. 16°.

D. APPLETON & CO.

HAVE JUST PUBLISHED

I.

The Primitive Family in its Origin and Development.

By Prof. C. N. STARBUCK, of the Copenhagen University. Volume LXV of the International Scientific Series. 12mo. Cloth, \$1.75.

II.

How to Study Geography.

By FRANCIS W. PARKER, Principal Cook County (Illinois) Normal School. Volume 2 of the International Education Series. Edited by WILLIAM T. HARRIS, LL.D. 12mo. Cloth, \$1.50.

RECENTLY PUBLISHED.

The History of Ancient Civilization. A Hand-Book based upon M. Gustave Ducaudrey's "Histoire Sommaire de la Civilisation." Edited by the Rev. J. VERSCHOYLE, M.A. With Illustrations. Large 12mo. Cloth, \$1.75.

A Manual of Instruction in the Principles of Prompt Aid to the Injured. Designed for Military and Civil Use. By ALVAH H. DORR, M.D., Major and Surgeon, Ninth Regiment, N. G., 8. N. Y.; Assistant Surgeon to Bellevue Hospital Dispensary. With 96 Illustrations. 12mo. Cloth, \$1.25.

A Treatise on Co-operative Savings and Loan Associations, including Building and Loan Associations, Mutual Savings and Loan Associations, Accumulating Fund Associations, Co-operative Banks, etc. With Appendix containing Laws of New York, Pennsylvania, and Massachusetts. Formed of Articles of Associations, By-Laws, Account Books, etc. By SEYMOUR DEXTER, President of "The Chemung Valley Mutual Association." 12mo. Cloth, \$1.25.

The Playtime Naturalist. By Dr. J. E. TAYLOR, F.L.S., Editor of "Science-Gossip." With 366 Illustrations. 12mo. Cloth, \$1.50.

Mental Evolution in Man: Origin of Human Faculty. By GEORGE JON ROBINSON, F.R.S., author of "Mental Evolution in Animals," etc. 1 vol., 8vo. Cloth, \$3.00.

The Folk-Lore of Plants. By T. F. THISELTON DYER, M.A. 12mo. Cloth, \$1.50.

**Nature and Man: Essays, Scientific and Philo-
sophical.** By the late WILLIAM BENJAMIN CARPENTER, M.D., F.R.S., with an Introductory Memoir by J. ESTLIN CARPENTER, M.A., and a Portrait. Large 12mo. Cloth, \$2.25.

At all Booksellers: or by mail on receipt of price.

1, 3, & 5 BOND STREET, NEW YORK.

LONGMANS, GREEN & CO.'S NEW BOOKS.

Lord Randolph Churchill's Speeches.

From 1880 to 1888. Revised and Corrected by himself. With an Introductory Review and Notes to the Speeches by Louis J. Jennings, M.P., editor of "The Croker Papers," etc. 2 vols., 8vo, \$7.00.

"Brilliant record of a brilliant decade."—*New York Tribune*.

"The reader will be favorably impressed with the consistency of these speeches."—*Observer*.

The Bird-Bride:

A Volume of Ballads and Sonnets. By Graham R. Tomson. Fcp. 8vo, \$1.75.

"The author is a born artist in verse. . . . Not one of the ballads but has the true glamour of imagination. . . ."—*Scottish Leader*.

"An altogether charming little volume, which lovers of the Muse will hasten to add to their collection."—*Globe*.

Lectures on Pathological Anatomy.

By Samuel Wilks, M.D., F.R.S., Consulting Physician to, and formerly Lecturer on Medicine and Pathology at, Guy's Hospital, and the late Walter Moxon, M.D., F.R.C.P., Physician to, and some time Lecturer on Pathology at, Guy's Hospital. Third Edition, thoroughly Revised. By Samuel Wilks, M.D., LL.D., F.R.S. 8vo, \$6.00.

Life of Charles Blacker Vignoles, F.R.S., F.R.A.S., M.R.I.A., &C.

Soldier and Civil Engineer, formerly Lieutenant in H.M. 1st Royals, Past-President of Institution of Civil Engineers. A Reminiscence of Early Railway History. By his son, Olinthus J. Vignoles, M.A., Assistant Minister of S. Peter's Church, London. With several Portraits and Illustrations. 8vo, \$5.00. (Dedicated to H.M. the Queen.)

On Parliamentary Government in England.

Its Origin, Development, and Practical Operation. By Alpheus Todd, LL.D., C.M.G. Second edition. In 2 volumes. Vol. II. 8vo, \$10.00. Very shortly. *8. Vol. I, 8vo, \$7.50.

Prince, Princess, and People;

An Account of the Social Progress and Development of our own Times, as illustrated by the Public Life and Work of their Royal Highnesses the Prince and Princess of Wales, 1863-1889. By Henry C. Burdett. With Portraits and Autographs of their Royal Highnesses and Illustrations of their Norfolk House. 8vo, \$6.00.

"Careful, conscientious and painstaking as a work of reference, and the author's style and treatment of his subject is marked not only by dignity and decorum, but by great tact and delicacy of feeling."—*Observer*.

Longmans' New Atlas.

Political and Physical, for the Use of Schools and Private Persons. Consisting of 40, 40 and 16 8vo Maps and Diagrams, besides Insets and 16 40 Plates of Views, &c. Engraved and Lithographed by Edward Stanford. Edited by G. G. Chisholm. Imp. 8vo., \$4.00. 4to, \$4.50.

The Student's Atlas.

In Twelve Circular Maps on a Uniform Projection and one Scale, with two Index Maps. Intended as a *vide-mecum* for the Student of History, Travel, Geography, Geology, and Political Economy. By R. A. Proctor. With a letterpress Introduction illustrated by several cuts. 8vo, \$1.50.

"We have seldom had such a rare treat offered to us as the inspection of this beautiful volume has afforded. It is well-nigh impossible, in the small amount of space available to us, to dwell adequately upon all the various and novel features here represented."—*The Teachers' Aid*.

Social Progress: an Essay.

By Daniel Greenleaf Thompson, President of the Nineteenth Century Club of New York, Author of "The Problem of Evil," "The Religious Sentiments of the Human Mind," etc. 8vo, \$2.00.

"Mr. Thompson is an acute and careful observer himself, and a systematic student of the results put forward by other workers."—*Contemporary Review*.

For sale by all Booksellers. Sent on receipt of price by the Publishers,

LONGMANS, GREEN & CO., 15 East Sixteenth Street, New York.

"building and loan associations." The author is president of a prosperous association, and thoroughly familiar with the details of management. Professor Henry Drummond will make an earnest appeal for the United States to join in the work of suppressing slavery in Africa. He says, "America has never been provincial. She must not become so. So manifold and pressing are now the interests of her own great country, that she might also be pardoned if she did. But the world will be bewildered and disappointed if she separates herself now from the rest of mankind in facing those great wrongs of humanity from which seas cannot divide her, and which her poorer brethren in every part of Europe are giving themselves to relieve. America does well in refusing the entanglements of European politics. Let her be careful lest she isolate herself from its humanities. None who know her will fear for a moment that the breadth of her sympathies and the greatness of her national heart will not continue to be shown in her sustained philanthropies, in her joining hand to hand with the advanced nations of the earth in helping on all universal causes which find their appeal in the world's great need and tribulation." Although the series on electricity will begin in the June number, there are several more of the railway articles to appear. Mr. H. G. Prout, of the *Railway Gazette*, will write of "Safety Appliances;" and Benjamin Norton, second vice-president of the Long Island Railroad, will describe the purchasing and supply departments under the title "How to Feed a Railway."

—A sympathetic sketch of the work of Mr. Bright, by Dr. R. W. Dale, forms the opening paper of the *Contemporary Review* for May (New York, Leonard Scott Publication Company, 29 Park Row). Dr. Dale admits it is yet too early to determine what rank will be permanently attributed to Mr. Bright among English statesmen, but contends there need be no hesitation in expressing the profound impression which his great personal qualities have made upon his contemporaries. The paper is accompanied by two pages of facsimiles of notes of speeches made by Mr. Bright, together with a full report, thus affording an interesting insight into his method of work. Lord Chief Justice Fry contributes an interesting and suggestive paper on "Imitation as a Factor in Human Progress;" Thomas Burt, M.P., presents a review of the progress of labor politics as represented in the British Parliament; T. Vincent Tynn makes another addition to the agnostic controversy now taking so prominent a place in the English reviews, in a paper on "Agnostic Expositions;" Edward T. Cook brings together many curious facts concerning popular judgment of works of art in an article on "Prices at the National Gallery;" Mr. W. S. Lilly contributes the first of a series of papers on Mr. Herbert Spencer in a paper entitled "Our Great Philosopher;" Grant Allen writes on "Individualism and Socialism;" and C. S. Addis, on "Railways in China." The number concludes with a valuable symposium on "The Industrial Value of Technical Training," with opinions of practical men. The contributors include Lord Hartington, president of the National Association for the Promotion of Technical Education, and numerous representatives of manufacturers in England.

INDUSTRIAL NOTES.

A Satisfactory Motor.

OVER a year ago the Spokane Falls Chronicle Company of Spokane Falls, Washington Territory, decided to operate their presses by electric power, and purchased a 2-horse-power Sprague motor for the purpose. Since that time, this motor has been running one standard Babcock cylinder press and two quarto job presses at the same time, giving great satisfaction. The proprietor of the *Chronicle* says that during this time it has not cost one cent for repairs, and is in every particular just as good as when it was installed, and that the Chronicle Company are perfectly satisfied with their electrical power.

Some Contracts closed Last Week.

During the past week the street-railway companies which are about adopting the electric system for operating their cars have not been idle, and the Sprague Electric Railway and Motor Company of New York report a number of new contracts closed during

—The *Fortnightly Review* for May (New York, Leonard Scott Publication Company) opens with an essay by Lord Wolseley, entitled "Is a Soldier's Life worth Living?" which he answers in the affirmative; William Archer makes a plea for an endowed theatre, urging that such an institution would render possible the production of many plays that are now never seen; Arsene Hous-saye concludes his reminiscences of Alfred de Musset, begun in the April number; an unsigned paper, "What is Ritualism?" will doubtless attract a wide circle of readers; Professor Karl Blind contributes a series of personal recollections of John Bright; F. C. Selous describes the newly acquired Mashunaland, treating of an almost totally unknown portion of Africa; Lady Dilke contributes a paper on the foreign missions controversy, that has been prominent in this review, in a short article entitled "The Great Missionary Success;" Hamilton Aide has a thoughtful paper on "Color in Domesticity and Dress;" Thomas H. Thornton presents an interesting sketch of the development of English judicial and administrative history in a paper entitled "Two Centuries of Magistrates' Work in Surrey;" Col. Maurice criticises present systems of military training; and Professor Tyrrell views "Robert Elsmere as a Symptom," and finds serious fault with Mrs. Ward's literary style. The number concludes with an article by Cardinal Manning on "The Educational Commission and the School Rates," in which he argues for the extension of popular education.

LETTERS TO THE EDITOR.

* * * Correspondents are requested to be as brief as possible. The writer's name is in all cases required as proof of good faith.

The editor will be glad to publish any queries consonant with the character of the journal.

Twenty copies of the number containing his communication will be furnished free to any correspondent on request.

The Ether and the Earth's Atmosphere.

I HAVE read with much interest Messrs. Michelson and Morley's wonderfully delicate experiment attempting to decide the important question as to how far the ether is carried along by the earth. Their result seems opposed to other experiments showing that the ether in the air can be carried along only to an inappreciable extent. I would suggest that almost the only hypothesis that can reconcile this opposition is that the length of material bodies changes, according as they are moving through the ether or across it, by an amount depending on the square of the ratio of their velocity to that of light. We know that electric forces are affected by the motion of the electrified bodies relative to the ether, and it seems a not improbable supposition that the molecular forces are affected by the motion, and that the size of a body alters consequently. It would be very important if secular experiments on electrical attractions between permanently electrified bodies, such as in a very delicate quadrant electrometer, were instituted in some of the equatorial parts of the earth to observe whether there is any diurnal and annual variation of attraction, — diurnal due to the rotation of the earth being added and subtracted from its orbital velocity; and annual similarly for its orbital velocity and the motion of the solar system. GEO. FRAS. FITZ GERALD.

Dublin, May 2.

the past week. One of these is at Plattsmouth, Neb., where the Plattsmouth Street Railway Company have closed their contract with the Sprague Railway and Motor Company at Kearney, Neb., for a complete electric-railway equipment. The Pennsylvania Railroad have been so well pleased with the operation of the Sprague cars at Atlantic City, N.J., that they have ordered ten more complete trucks. In Binghamton, N.Y., the Washington Street and State Asylum Railroad has closed a contract with the Sprague Company to equip their line with the latest improved railway appliances, and latest type of motors.

The list of roads which have closed contracts during the week ending May 11, 1889, is as follows: Atlantic City Electric Railroad, extension, Atlantic City, N.J.; Collamor Line, East Cleveland, O.; Key City Electric Railroad, Dubuque, Io.; Long Island and Newtown Electric Railroad, Long Island City, N.Y.; Plattsmouth Electric Railroad, Plattsmouth, Neb.; Union Electric Railroad, Sterling, Ill.; Washington Street and State Asylum Railroad, Binghamton, N.Y.

GUARANTY INVESTMENT COMPANY

CAPITAL \$250,000.

Hon. ALBERT H. HORTON (Chief Justice, Kansas Supreme Court), Topeka, Kan., Pres't.

7% Guaranteed Farm Mortgages 7%

The Company calls the special attention of Investors to the following points :

- I. All loans guaranteed and interest payable semi-annually at the Importers' & Traders' National Bank, New York.
- II. Unusual fulness of information, not only about the security itself, but about the general development of the section where the farm is located.
- III. An examination each year of the general business of the Company and the Mortgages themselves by a COMMITTEE OF INVESTORS sent for the purpose.
- IV. Many hundred Mortgages taken and NOT A SINGLE FORECLOSURE.
- V. Exhibitions in New York at frequent intervals, of Kansas and Nebraska Farm Products. The Exhibition at the American Institute in the fall of 1888, received the *HIGHEST AWARD* of superiority.
- VI. Monthly Bulletins giving full information about all Mortgages offered for sale.

Address for Monthly Bulletin and Investors' Committee Report for 1888,

HENRY A. RILEY, General Eastern Manager, 191 Broadway, N.Y.

16 PAGES. THREE PAGES.

Hundred Thousand new subscribers for *The Family Journal and Ladies' Companion* wanted. It is the most interesting and instructive paper ever issued. Subscribers will receive during the coming twelve

MONTHS

novels written by American Authors, complete in each three numbers. The story of popular works of fiction will be retold by a novel reader, the most interesting and unique feature ever introduced in any publication, giving the substance of popular and standard books by famous writers in a space easily read by the busiest people. We have engaged

FOR

this work a widely known and popular writer. Comments on Current Events, Fashions, New and Original Ideas and Designs for Ladies' Fancy Work and Household Decoration. Letters from correspondents and their answers. The colleges and seminaries of the United States will be treated once each month in an illustrated article, showing the particular advantage of each, cost of attendance, etc. Invaluable to parents having sons or daughters whom they desire should receive the advantages of a higher education than the ordinary school affords. Articles on Painting and Drawing, giving home instruction by a well-known artist. A trial subscription of this elegant paper will be sent to any address, three months, for

TEN CENTS.

Liberal pay for literary work adapted to our columns, and for new and original drawings, designs followed by no other publishing houses.

Premium List the most complete in the world. We offer inducements to club raisers and agents approached by no other publishing houses. The celebrated Gilbert Cut Waist Linings, which we send post paid to any one sending us two yearly subscribers at 50 cents each in advance worth 75 cents.

50¢ Sent to any address, postpaid one year, 50 cents; six months, 25 cents, and a three months' trial subscription for only 10 cents.

TRY IT! TRY IT! TRY IT! and you will become a permanent reader. Address:

John L. Douglass, Publisher,
322 Broadway, N. Y.,

ESTABLISHED 1859.
H. A. DREW,
Commercial Printer,
5 Clinton Place, near Broadway,
New York.

Wedding Orders, Souvenirs, Invitations, Orders of Dance, etc., etc., done in the latest and most elaborate styles, at reasonable prices.
All Favors promptly attended to.

Correspondence solicited with parties seeking publishers for scientific books.

N. D. C. HODGES,
Publisher of Science,
47 Lafayette Place,
New York.

"The Week, one of the ablest papers on the continent."—*Descriptive America.*

ENLARGED AND IMPROVED.

THE WEEK:

A Canadian Journal of Politics, Literature, Science and Arts.

PUBLISHED EVERY FRIDAY.

\$3.00 per Year.

\$1.00 for Four Months.

THE WEEK has entered on its SIXTH year of publication, greatly enlarged and improved in every respect, rendering it still more worthy the cordial support of every one interested in the maintenance of a first-class literary journal.

The independence in politics and criticism which has characterized THE WEEK ever since its first issue will be rigidly maintained; and increasing efforts will be made to improve its literary character and increase its value and attractiveness as a journal for the cultured home. Many new and able writers are now, or have promised to become, contributors to its columns, and the constant aim of the Publisher will be to make THE WEEK fully equal to the best literary journals in Britain and the United States.

As heretofore, PROF. GOLDWIN SMITH will, from time to time, contribute articles. London, Paris, Washington and Montreal letters from accomplished correspondents will appear at regular intervals. Special Ottawa Letters will appear during the sessions of Parliament.

THE WEEK in its enlarged form will be the same size as "Harpers' Weekly," and the largest paper of its class on the continent.

SEND FOR FREE SAMPLE COPY.

C. BLACKETT ROBINSON, Publisher,
5 Jordan St., Toronto.

Readers of Science

Corresponding with or visiting Advertisers will confer a great favor by mentioning the paper.

Schools.

The Sauveur Summer College OF LANGUAGES.

(Removed from Amherst, Mass., and Oswego, N. Y., to BURLINGTON, VT.)

The Normal Class will be taught for the French by Dr. Sauveur, for the German by Dr. W. Bernhardt, for the Latin by Prof. J. U. Dillard. Fourthenth Session: July 8 to August 16.

Dr. Sauveur's new work, LES CHANSONS DE BERANGER, with Historical Commentary and Notes, will be ready June 1, and taught at the School. For Circulars address

DR. L. SAUVEUR,

Copley Terrace, Roxbury, Boston, Mass.

N.B.—Circulars of Dr. L. SAUVEUR Educational Works will be sent free to applicants. (Mention this paper.)

CONNECTICUT, NEW HAVEN,

MRS. CADY'S SCHOOL FOR YOUNG LADIES. Prepares for Smith and Wellesley, and admits to Vassar by Certificate. Circulars. Early application necessary.

NEW JERSEY, PLAINFIELD.

THE CHESTNUTS.—Parents with daughters to educate, or orphan girls with companion, may find a comfortable home, with school instruction by applying to Miss E. E. Kenyon.

A NEW MAGAZINE—THE SWISS CROSS

Devoted to spreading a love of nature among the people. Edited by HANLAN H. BALLARD, President of the Agassiz Association, and succeeding St. Nichol's as the official magazine of that body. \$1.00 a year. Sample copies 10 cents, or 25 cents for trial subscription for 3 months. N. D. C. HODGES, PUBLISHER, 47 Lafayette Place, New York. Mention this paper.

Any one who will have the following blank filled out by a responsible Newsdealer, and mailed to us, will be allowed a three months' subscription to Science.

N. D. C. HODGES,

47 LAFAYETTE PLACE, NEW YORK.

To the News Company.

You may add to my regular order five copies of SCIENCE each week (returnable).

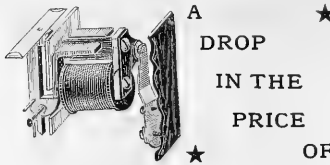

GRAVITY DROP ANNUNCIATORS.

DON'T FORGET THE DUST-PROOF BELLS.

HAZAZER & STANLEY, 32 Frankfort Street, N. Y.

SCIENCE CLUBBING RATES.

Table with columns: 10% DISCOUNT, Year's Subscription, With Science, With The Swiss Cross. Lists various journals and their rates.

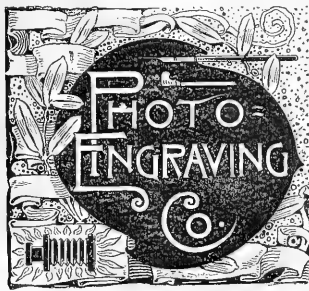

JOHN HASTINGS = Pres't. A=R=HART = Gen. Manager. J=OS=TRIPP = V. Pres't. ENGRAVING FOR ALL ILLUSTRATIVE AND ADVERTISING PURPOSES

BRANCH AT 72 B. CHESTNUT ST. PHILADELPHIA, PA.

67-71 PARK PLACE, NEW YORK.

N. D. C. HODGES, 47 Lafayette Place, New York.

C. & C. ELECTRIC MOTOR COMPANY.

Electric Motors
FOR
Arc and Incandescent Cir-
cuits, Most Economi-
cal Motor on the
Market.
Regulation Perfect.
Motors Designed for all
Power Purposes.

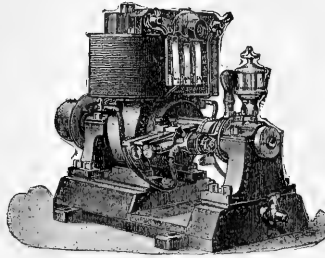

OFFICE and MANUFACTORY:
402 and 404 Greenwich Street, New
York City.

New England Office, 19 Pearl St., Boston.

Philadelphia Office, 301 Arch St.

Western Office, 139-141 Adams Street,
Chicago.

Southern Office, 25 Carondelet Street,
New Orleans.

THE American Bell Telephone COMPANY. 95 MILK ST., BOSTON, MASS.

This Company owns the Letters
Patent granted to Alexander Gra-
ham Bell, March 7th, 1876, No.
174,465, and January 30, 1877,
No. 186,787.

The Transmission of Speech by
all known forms of ELECTRIC
SPEAKING TELEPHONES in-
fringes the right secured to this
Company by the above patents, and
renders each individual user of tel-
ephones, not furnished by it or its
licensees, responsible for such un-
lawful use, and all the conse-
quences thereof and liable to suit
therefor.

**ESTERBROOK'S
STEEL PENS.**
OF SUPERIOR AND STANDARD QUALITY.
Leading Nos.: 048, 14, 130, 135, 239, 333
For Sale by all Stationers.
THE ESTERBROOK STEEL PEN CO.,
Works: Camden, N. J. 26 John St., New York.

Wants.

A YOUNG MAN can have lucrative engage-
ment, not only a fixed salary, but accord-
ing to his work accomplished in travelling for
SCIENCE. A personal interview invited.

N. D. C. HODGES,

47 Lafayette Place, New York.

M ECHANICIAN.—An optician and maker
of instruments of precision of experience
would be glad of a position where his skill
would be valued in connection with some higher
educational institution. Address G. J., care of
SCIENCE, 47 Lafayette Place, New York.

Scientific Apparatus.

J. GRUNOW,
621 Sixth Avenue, New York.
Established 1852.

MAKER OF

Microscope Stands,
Oil Immersion Objec-
tives and Abbe Con-
densers for Bacterial
and Histological work,
of Objectives, Camera
Lucida and other ac-
cessory apparatus.

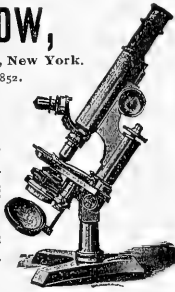

IMPROVED OIL LIGHT MAGIC LANTERNS.

Also Lime and Electric Light Apparatus, and
mechanical, plain, and fine colored views.

J. B. COLT & CO., Manufacturers,
No. 16 BEEKMAN STREET, NEW YORK.

MAGIC Stereopticons and the Best Views
LANTERNS for Public, Church, Home, and
Scientific Exhibitions. Best appar-
atus, new views. Largest stock. Reduced prices. 24
Years' Practical Experience. Illus. Catalogue Free.

GEO. H. PIERCE,
136 S. Eleventh St., Philadelphia, Pa.

ELECTRICAL TESTING BUREAU,

Johns Hopkins University, Baltimore, Md.
Resistance Coils and Boxes Compared.
Am meters and Volt meters calibrated.
Condensers standardized.
Primary and Secondary Batteries Tested.
Efficiency of Dynamos and Motors Deter-
mined.
Insulation of Cables and Wires Tested.
Etc., Etc.
Circulars describing Methods Used, Prices,
Etc., sent on Application.
Address as above.

MORRIS EARLE & CO.
SUCCESSORS TO
R. & J. BECK,
1016 Chestnut Street Phila

Microscopes and all
Accessories and Appa-
ratus. Photograph-
ic and Photo-Micro-
graphic Apparatus and
Outfits.

Spectacles, Eye
Glasses, Opera and
Marine Glasses, etc.

Illustrated Price List
mailed free to any ad-
dress. Mention SCIENCE
in corresponding with us.



E. & H. T. ANTHONY & CO.
591 Broadway, N. Y.
Manufacturers and Importers of
PHOTOGRAPHIC INSTRUMENTS,
Apparatus and Supplies of every
description. Sole proprietors of the
Patent Detective, Fairy, Nov-
el, and Bicycle Cameras, and the
Celebrated Stanley Dry Plates.
Amateur Outfits in great variety, from \$5.00 upward.
Send for Catalogue or call and examine. *ESTD* More
than 40 years established in this line of business.

**THE GREAT AMERICAN
TEA COMPANY**
**GOOD NEWS
TO LADIES.**
Greatest Inducements ever of-
fered. Now's your time to get
up orders for our celebrated
Teas and Coffees, and secure
a beautiful Gold Band, Ivory
Rose China Tea Set, Dinner Set,
Gold Band Moss Rose Toilet Set, Watch, Brass Lamp,
or Webster's Dictionary. For full particulars address
THE GREAT AMERICAN TEA CO.,
P. O. Box 289. 81 and 83 Vesey St., New York

A TEMPORARY BINDER

for Science is now ready, and will be mailed
postpaid on receipt of price.

Half Morocco - 75 cents.



This binder is strong, durable and
elegant, has gilt side-title, and allows
the opening of the pages perfectly
flat. Any number can be taken out
or replaced without disturbing the
others, and the papers are not mui-
lated for subsequent permanent bind-
ing. Filed in this binder, *Science* is
always convenient for reference.

N. D. C. HODGES,

47 Lafayette Place, N. Y.

Readers of Science

Corresponding with or visiting Ad-
vertisers will confer a great favor by mention-
ing the paper.

Arnold,
Constable & Co.

PARIS MADE SUITS,
Wraps and Jackets,
LACE AND EMBROIDERED DRESSES,
Gaze and Crepe Fabrics
For Evening Wear.

Broadway & 19th St.
New York.

SUMMER DRESSES.

We call attention to the following specialties for this week:

Black and White Striped Armure Royale, at 80 cents; regular price, \$1.15.

Black Satin Princess, \$1; regularly, \$1.25

1,000 yards Pekin Printed Foule at 75 cents per yard, case price, \$1.25.

1,500 yards Figured Bengaline, at 75 cents, former price, \$1.25.

1,750 yards Silk Warp Henrietta, at 75 cents, usual price \$1.

These fabrics are all peculiarly adapted for use at this season of the year.

JAMES McCREERY & CO.

BROADWAY AND ELEVENTH STREET,
NEW YORK.

IMPROVING THE MEMORY PICK

and facilitating the acquirement of knowledge by lectures and correspondence. Classes forming. "MEMORY and its Doctors," from Simonides to "Loisette," mailed for 10 cents.
DR. PICK, 24 Union Square, N. Y. City.

FOOD ADULTERATION

And its Detection. With photomicrographic plates and a bibliographical appendix. By J. P. Battershall. 328 pages, 8vo, cloth. Price, \$3.50. Circulars and Catalogues on application. E. & F. N. SPON,
12 Cortlandt St., New York.

**KIMBALL'S
STRAIGHT CUT
CIGARETTES.**

Unsurpassed in quality.
Used by people of refined taste.
Highest award at Brussels, 1888.
The finest smoking mixtures are of our manufacture.
Fifteen First Prize Medals.
WM. S. KIMBALL & CO.,
Rochester, N. Y.



The Mutual Life Insurance Company

OF NEW YORK.

RICHARD A. McCURDY, PRESIDENT.

ASSETS - - - \$126,082,153 56

The Largest and best Life Insurance Company in the World.
The New Business of the Mutual Life Insurance Company in 1888
Exceeded \$103,000,000.

Its Business shows the Greatest Comparative Gain made by
any Company during the past year including

A gain in assets of.....	\$ 7,275,301 68
A gain in income of.....	3,096,010 06
A gain in new premiums of.....	2,333,406 00
A gain in surplus of.....	1,645,022 11
A gain in new business of.....	33,756,792 85
A gain of risks in force.....	54,496,251 85

The Mutual Life Insurance Company

Has Paid to Policy-holders since Organization \$272,481,839 82.

PARIS EXPOSITION.

The Cheque Bank issues Cheques, either singly or put up in Books, for the special use of VISITORS to the PARIS EXPOSITION, who can cash the same at upwards of seventy Banking Houses, situated in different parts of Paris, without charge.

Visitors mail matter can be addressed to them, Care of the Societe Generale, 4 Place de l'Opera, opposite the Grand Hotel, where English is spoken.

Every Cheque that is issued by the Cheque Bank is EQUAL TO CASH, as Bank Notes are, for the Bank's Capital, Guarantee Fund and Customers' Balances are invested in British Government Securities, or held in Cash in the Bank of England, and can be cashed in every town in Europe without charge.

For Handbook containing list of 2,500 Banking Houses who cash the cheques, free of charge, apply to

CHEQUE BANK, Limited,
Capital, £100,000. Guarantee Fund, £27,000.
Trustees, The Right Honourable John Bright, M.P.,
The Right Honourable Earl Beauchamp.
NO. 2 WALL STREET, NEW YORK.

Visitors to Europe and Paris Exposition should carry a book containing Cheque Bank Cheques, which are absolutely safe and cheaper than Letters of Credit, and much more convenient; are payable on presentation without charge at 2,500 Banking Houses and 250 of the principal Hotels in Europe.

A RARE CHANCE FOR A COLLEGE.
For sale—1,300 FINE COINS and MEDALS, silver, gold, bronze, a history in coins commencing with the fifteenth century, representing over 500 historical persons and 175 countries and cities. Address:
L. D., P.O. Box 1337, New York.

Old and Rare Books.

One Million Magazines. Back numbers, vols. and sets—old and new, Foreign and American.
CATALOGUE UPON APPLICATION.

A. S. CLARK,
34 Park Row, New York City.

BACK NUMBERS and complete sets of leading Magazines. Rates low. AM. MAG. EXCHANGE, Schoharie, N. Y.

H. WILLIAMS,
Dealer in Old Magazines, Reviews, &c. Scientific periodicals a specialty. 39 Macdougal St., N. Y.

SOMETHING NEW
THE PATENT
ADJUSTABLE BRUSH.

LIQUID GLUE
ALWAYS
READY FOR USE

Patent Pocket Can. No waste.

THE STRONGEST
GLUE
2 IN THE WORLD.
GOLD MEDALS

RUSSIA & CO.
Manufacturers, Mass.

Used by thousands of first-class mechanics and by such manufacturers as Fulton, Palace Car Co., Mason & Hamlin Organ and Piano Co., &c., &c.

Repairs Everything.
Its success has brought a lot of imitators copying us in every way possible. Remember that THE ONLY GENUINE LePage's Liquid Glue is manufactured solely by the
RUSSIA CEMENT CO.
GLOUCESTER, MASS.
Send 10c. and dealers' card who doesn't keep 10c. in stock, for sample.

Readers of Science
Corresponding with or visiting Advertisers,
will confer a great favor by mentioning this paper.

WHY YOU SHOULD USE

Scott's Emulsion
OF Cod Liver Oil WITH
HYPOPHOSPHITES.

It is used and endorsed by Physicians because it is the best.

It is Palatable as Milk.
It is three times as efficacious as plain
Cod Liver Oil.
It is far superior to all other so-called
Emulsions.

It is a perfect Emulsion, does not separate or change.
It is wonderful as a flesh producer.
It is the best remedy for Consumption,
Scrofula, Bronchitis, Wasting Diseases,
Chronic Coughs and Colds.

Sold by all Druggists.
SCOTT & BOWNE, Chemists, N. Y.

LIBRARY OF THE U. S. NATIONAL BUREAU OF STANDARDS
133648
MAY 25 1889
SCIENCE

SCIENCE

[Entered at the Post-Office of New York, N. Y., as Second-Class Matter.]

A WEEKLY NEWSPAPER OF ALL THE ARTS AND SCIENCES.

SEVENTH YEAR.
VOL. XIII. No. 329.

NEW YORK, MAY 24, 1889.

SINGLE COPIES, TEN CENTS.
\$3.50 PER YEAR, IN ADVANCE.

THE DAFT ELECTRIC ROAD IN CINCINNATI.

In response to the request for data as to the electric road known as the "Kerper Walnut Hills Electric Road," now being operated by the Daft system of double-trolley underneath contact, it may be said that it is not generally known that this is the only system of double-trolley underneath contact in successful commercial operation in the United States to-day. It is not intended to imply that there had not been attempts made in this direction; but it has generally been claimed, that, with parallel wires, a double underneath

as presenting features which would recommend itself to the general public. Some difficulty was met with in the operation of this road at first, owing to the peculiar demands made upon it at the McMillan Street and Gilbert Avenue junction. Here concentrates an enormous traffic from the Walnut Hills district and the outlying suburbs; in fact, the narrow artery at the head of Gilbert Avenue was practically the only outlet for the vast traffic into and out of Cincinnati.

To Mr. George B. Kerper great credit is due for the solving of what was a most vexatious problem. By him a further extension



DAFT ELECTRIC ROAD, WALNUT HILLS, CINCINNATI.

contact was impracticable. Not that such operation was not desirable, because the obtainment of absolute freedom from interruption to telegraphic, telephonic, and fire-alarm service that such a system gave, could not well be any thing else but desirable.

To Mr. George B. Kerper, the president of the Mount Adams and Eden Park Inclined and Gilbert Avenue Railways, credit is due for the introduction of electricity for the operation of street-railways in Cincinnati. More than a year ago he foresaw that this new force was moving rapidly to the front in its adaptability to street-car propulsion. Casting about, he selected the Daft system

of the road into Mount Adams and Eden Park Cut was determined upon, a new contract was made, and in thirty days from the date thereof the Daft Electric Company had completely reconstructed the whole line, refurnished its entire equipment, substituting the double underneath for the double overhead contact, and, without a break, set the car in commercial operation.

As a confirmation of the judgment of Mr. Kerper as to the value of the Daft system, the remarkable manner in which this double underneath contact trolley furnished by the Daft Company fulfils its purpose, the symmetrical and enduring character of its struc-



DAFT ELECTRIC ROAD, CINCINNATI, ROUNDING CURVES.

ture, the high speed of the cars (going much faster than the cables), the easy motion of the car, the freedom from jerking and lack of danger elements, fully attest the wisdom displayed.

The cars as now equipped are able to tow additional cars, their equipment being of sufficient power. They have fully demonstrated their efficiency in many instances; in one case having pushed the Avondale cars up the 7½-per-cent May Street grade when the horses were stalled from overloading, and in another pushing the heavy cable-trains back upon the track at a recent occurrence.

The performance of regular commercial service by these Daft motor cars over a road upon which there are not over six hundred feet of straightaway track (in one mile there being six cross-overs, eight curves, and grades as high as 7½ per cent, travelling for a portion of the road over a regular cable-line), and the ease with which they are able to run away from the cable-cars, mounting grades continuously wet by street-sprinkling carts, demonstrate that the Daft system in Cincinnati has scored a complete success, and justifies the confidence reposed in it by the managers of the street-railway company.

Praises for the manner of its construction, its equipment, and its operation, are heard everywhere. One of the most remarkable features about this line is the double underneath contact trolley. It requires no attention from driver or conductor: in fact, were it not for the ordinances requiring a conductor to each car, his services would be wholly unnecessary. The trolley moves with the same ease as the car upon the track, and its liability to leave the wires is very much less. Its construction is such that it regulates itself to all the various dips, angles, curves, etc., with the greatest facility.

Another important feature of the Daft system is its great economy.

The power is taken from the engine which drives the Gilbert Avenue cable, and so some fluctuation of speed in the generator results, but not sufficient to interfere in any way with the successful operation of the electric road.

Half-hourly records are kept of voltmeter and ammeter readings, the dynamo speed, and the temperature of the engine-room. From these it can readily be seen when the car is ascending grades, when descending, when at grade, when with more than an ordinary load, etc. At the dynamo station it is practicable to tell at any hour of the day the relative position of the cars to the line. Power is only absorbed by the motors upon the car to meet the requirements made upon it by their several loads. Of course, under such circumstances, when there is no demand for power, there can be no expenditure, and the result is the highest economy. It is usual with street-railway people to base the success of any system, whether it be by horses, by cable, or by electricity, upon the dollar-and-cents basis. In this respect the Daft system recommends itself to thoughtful business-men.

INSECTICIDES AND THEIR APPLICATION.

As the season of the annual warfare between vegetable life and its insect enemies has come round once more, our readers will probably find interesting a report on insecticides recently published by the Ohio Agricultural Experiment Station. The director of the station states that insecticides, or the substances used for destroying insects, may broadly be divided into two classes: (1) internal poisons, or those which take effect by being eaten along with the ordinary food of the insect; and (2) external irritants, or those which act from the outside, closing the breathing-pores, or causing death by irritation of the skin. Besides these, however, various other substances are used in preventing insect-attack, keeping the pests away because of offensive odors, or acting simply as mechanical barriers.

The most important insecticides are the poisons. Of these the most popular are the various combinations of arsenic, known as "Paris green," "London purple," "slug-shot," and a large number of patent insecticides sold under various names.

Paris green is a chemical combination of arsenic and copper, called arseniate of copper. It contains about fifty-five or sixty per cent of arsenic, and retails at about thirty cents per pound. It is

practically insoluble in water, and may be applied either dry or wet. In the former case it should be well mixed with some fine powder as a diluent; plaster, air-slacked lime, flour, road-dust, and finely sifted wood-ashes, all answer the purpose fairly well, though lime or plaster is usually preferable. The proportion of poison to diluent varies greatly with different users: one part poison, to fifty, and even one hundred, of diluent, will usually be effective, if the mixing be thoroughly done. In the wet mixture for fruit and shade trees, use one pound poison to 150 gallons water, and keep well stirred. The chief objection to Paris green is that it is so heavy that it settles quickly to the bottom of the vessel, — very much more quickly than London purple. It is also more expensive.

London purple is a by-product in the manufacture of aniline dyes, produced by Hemingway's London Purple Company of London, England. It contains nearly the same percentage of arsenic as Paris green, and is much cheaper, retailing at about fifteen cents per pound. It is a finer powder than the green, and consequently remains in suspension much longer. It may be used in the same way, — as a powder or in water, — and the proportions given above answer very well for it.

White arsenic is sometimes recommended as an insecticide, but fortunately is rarely used. It is much more dangerous to have around than either of the above highly colored compounds, and in practice is very liable to burn the foliage to which it is applied.

The principal substances used for killing insects, by contact, are the following: —

Hellebore is a powder made of the roots of a plant called white hellebore (*Veratrum album*). It is a vegetable poison, but much less dangerous than the mineral arsenical poison, and kills both by contact and by being eaten. It may be applied as a dry powder or in water (an ounce to three gallons). It retails at about twenty-five cents per pound, and is especially excellent for destroying the imported currant-worm.

Pyrethrum is an insecticide of recent introduction, made from the powdered flowers of plants of the genus *Pyrethrum*. There are three principal brands upon the market, known as "Persian insect-powder," "Dalmatian insect-powder," and "buhach," the last being a California product. The greatest obstacle to the use of pyrethrum has been the difficulty of obtaining the pure, fresh article. If exposed to the air, the poisonous principle volatilizes, and the powder is worthless: hence dealers should purchase a fresh supply each season, and should keep it in air-tight vessels. Pyrethrum is used mainly either as a dry powder or in water (one ounce to three gallons), but may also be used in the form of a tea or a decoction, a fume, or an alcoholic extract diluted. For use as a dry powder, it may advantageously be diluted with six or eight parts of flour. It is especially excellent for clearing rooms of flies and mosquitoes, and for killing the common cabbage-worms. It is practically harmless to man and the higher animals.

Kerosene emulsion is made by adding two parts of kerosene to one part of a solution made by dissolving half a pound of hard soap in one gallon of boiling water, and churning the mixture through a force-pump with a rather small nozzle until the whole forms a creamy mass, which will thicken into a jelly-like substance on cooling. The soap solution should be hot when the kerosene is added, but of course must not be near a fire. The emulsion thus made is to be diluted, before using, with nine parts cold water. This substance destroys a large number of insects, such as the chinch-bug, cabbage-worm, and white grub, and is a comparatively cheap and effective insecticide. Besides its use as an emulsion, kerosene alone is frequently used for various pests. It is especially valuable in destroying vermin on domestic animals and in hen-houses.

Carbolic acid, especially in its crude state, is valuable for various insecticidal purposes. An excellent wash for preventing the injuries of several tree-borers is made by mixing one quart soft soap, or about a pound of hard soap, with two gallons water, heating to boiling, and then adding a pint of crude carbolic acid. Carbolic-acid soaps are largely used for destroying vermin on domestic animals.

Tobacco is a very valuable insecticide for use against vermin on domestic animals and green-house pests. It may be used in the form of a decoction, a smoke, or dry. The refuse stems from the

cigar-factories are generally easy to obtain, and, if fresh, are effective in destroying the pests mentioned.

Bisulphide of carbon is a volatile substance used for destroying grain insects, ants, the grape phylloxera, and other insects which may be reached by a vapor. It is inflammable, and should never be used in the vicinity of a fire. Benzine is another volatile substance, used for much the same purposes as the last. Gasoline may also be mentioned in the same connection.

Coal-tar has been largely used in the West for destroying Rocky Mountain locusts, being placed on flat pans, on which the insects jump and are caught. It is also employed to prevent the migra-

opportunities; but it is absolutely necessary that the first attacks of the ravenous little creatures be promptly met. Do not delay a single day, for they increase in numbers with marvellous rapidity; and one day is sufficient for millions of eggs to be laid, to reproduce in a short time larger hosts, even should we be successful enough to destroy the original advance guard. Promptness in this will save one-half the trouble and expense later on. In applying insecticides, it should be borne in mind that "a little is as good as a feast." It is not necessary to drown the insects with solutions, or to bury them with powder, to kill them, — the least particle of poison is sufficient to do its deadly work, — but it is necessary that



LEGETT'S POWDER-GUN.

tions of the chinch-bug. A shallow V-shaped channel is made with the corner of a hoe along the borders of the field to be protected, and tar poured in. So long as the tar does not dry out, the immature chinch-bugs cannot cross it.

Lime and plaster are excellent for use in preventing the depredations of certain insects. Plaster may be dusted on melon and other vines to drive off flea-beetles; and fresh-slacked lime may be dusted or sprayed (a peck to fifty gallons of water) on grapes, peaches, etc., to prevent rose-beetle injuries. Gas-lime is sometimes recommended as an insecticide, but seems to be little used in America. It is valuable as a fertilizer, and can be obtained at little cost.

"the least particle" and the insect come in contact. It is much better to reach every portion of the plant or tree, underneath as well as above, with a fine spray of fluid or a slight dusting of powder, than to apply liberally in some parts and carelessly overlook others, as is the too general custom. To fight insects effectually, it must be done thoroughly, and every inch must be covered. Besides, there is much less danger of burning or injuring the leaves and fruit by light applications.

The recently improved implements for applying powders or fluids are great economizers, covering larger surfaces with less material, doing it with greater speed, and reducing the danger of injury to plants to a minimum. Among them we will mention



DOUBLE-CONE POWDER-BELLOWS.



VAPORIZING-BELLOWS.

Soluble phenyl and paraffine-oil are two English insecticides frequently recommended for trial here, but which are as yet little used. For the following facts concerning the newer inventions for the application of insecticides we are indebted to Peter Henderson & Co., seedsmen of this city.

The enormous damage done by insects to our fruits, vegetables, grain, etc., is almost beyond belief, — amounting, it is claimed by competent authorities, to from \$200,000,000 to \$250,000,000 per annum in the United States alone, — and their ravages are steadily increasing. Fortunately the extensive experiments in insecticides and implements for applying them enable us to fight them so well that the damage done is scarcely felt when the most is made of our

Leggett's powder-gun, in which a rapidly revolving fan-wheel blows the powder through a long tin tube with such force that it is widely and lightly distributed over a large surface. Sectional tubes can be added, so the powder will go up into the tallest fruit-trees; and, as the under side of the leaves are reached as well as above, it is an exceedingly effectual implement. A short curved tube comes with it for applying powders to low-growing plants, by which the under side of the foliage is reached as well. The supply of powder can be regulated to such a nicety, that Mr. Leggett claims he can make half a pound of London purple cover an acre. Woodason's improved double-cone bellows is also worthy of special mention. It is impossible to clog it, as a series of perforated tubes

run through the powder-chamber, keeping the powder constantly stirred up; and, no matter in what position it is held, the same regular supply is blown out. A detachable spout enables the operator to blow up under the foliage of vines and potatoes without stooping and getting into tiresome positions.

For applying fluids, there is an ingenious device nearly ready to be put on the market, which looks not unlike a Babcock fire-extinguisher. It is carried on the back of the operator, which enables him to carry twice the quantity of fluid with greater ease than by the old method, with a bucket. But its great merit lies in the fact that the fluid is forced out by compressed air, through two short pieces of hose, which are held in each hand, enabling two rows to be easily covered at a fair walk. The fluid can be applied in the form of mist, spray, or stream, at will; and, when the air has been exhausted, a few movements of the small pump-handle are sufficient to recharge it. Vaporizing-bellows are also exceedingly valuable for applying solutions of alcohol, kerosene, fir-tree oil, and other insecticide solutions of like character, which are such thorough insect-extermiators, but so dangerous to the plant when carelessly applied by syringe or sprinkler. With the vaporizing-bellows, these strong fluids can be applied almost like vapor, and the insects are killed without danger to the plants. Some of the newer spraying-pumps for orchard and field use are a step in the right direction. A "return discharge" is added, the mouth of which can be placed near the suction-pipe at the bottom of the barrel; and it keeps the solution thoroughly churned and mixed, as no stirring with a stick can do. When kerosene emulsion, fir-tree oil, or other oily insecticide is used, which rises naturally to the surface, the mouth of the return discharge should be placed on or over the surface. Kerosene, when intelligently applied, is a valuable remedy. We know of its being used, to the exclusion of all other insecticides, in greenhouses containing the rarest plants; and brighter, cleaner, healthier stock we never saw. But it is used with discretion. On woody and hardier plants, such as camellias, palms, azaleas, etc., one pint of kerosene to four gallons of water is used; and for delicate-foliaged plants, from one-third to one-half less kerosene is used. When applying the solution, one man is constantly drawing and forcing the fluid back through a syringe into the bucket, while another fills his syringe with the thoroughly churned solution, and applies it to the plants: therefore these return-discharge pumps are gotten up to work on the same correct principle as that of the two men just described, for applying not only kerosene, but London purple and Paris green poisoned waters as well; for these two powders are not soluble, and soon settle to the bottom, leaving the surface water too weak, and that at the bottom so strong that the foliage is likely to be injured.

Insect-killing powders are much more efficacious when blown into the plant than when dusted on, as is the usual practice. When blown on with a bellows or other implement, the powder separates into clouds of impalpable dust; and the force causes it to penetrate the innermost crevices, destroying the hidden insects and larvæ by filling their breathing-pores (which, as all know, are situated in rows on each side of their bodies), thus suffocating them. This is the main reason why non-poisonous powders are frequently as effectual as poisonous. We know of a firm of large cabbage-growers in Florida who have saved their crops for several years, while their neighbors' have been almost a total loss, simply by blowing Persian insect-powder of *high grade* into each plant with a finely-distributing bellows. Their men go over the fields occasionally, not stopping to see whether a cabbage is affected or not, and simply puff a small quantity of powder into each in a rapid, business-like manner; and the result speaks for itself. You will notice that we emphasize "high grade" in connection with the Persian powder. We do so, because the cheap grades are almost worthless. The "high grade infallible" is produced from the half-opened flowers and buds of *Pyrethrum roseum* or its hybrids, that from the collected wild flowers being superior to the cultivated; while the cheaper grade is made from opened flowers gathered later in the season, with frequently the flower-stems ground in; and lots of useless cheap stuff is sold which is made from the stalks and stems of the plant, ground and colored so finely that to the uninitiated it appears better than the superior grades. The insect-destroying properties of the Persian powder depend largely on the

fineness to which it is ground, enabling it to penetrate the breathing-pores of the insect, and on its resinous properties causing it to adhere and suffocate them. This resinous property is easily injured by exposure, and generally entirely destroyed by dampness. Dalmatian powder and buhach are made from the same family, grown in other sections of the world, the former being from Dalmatia, and the latter from California. All are equally good if the flowers are gathered at the proper stage and thoroughly ground. Persian powder has been considered superior, simply because it was formerly made under the supervision of the Hungarian Government, who exacted purity and other conditions which insured a high grade, which gave the powder its reputation. The pyrethrum

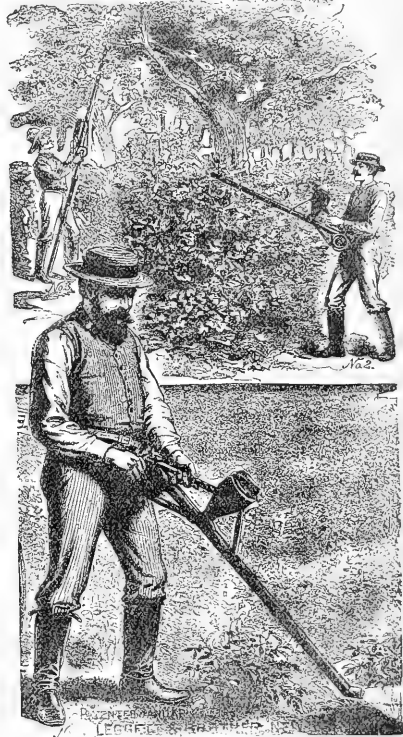

LEGGETT'S POWDER-GUN IN OPERATION.

grown in California has been proved to be equally as efficacious, when correctly prepared, as that from the Caucasian Mountains; the climatic conditions of the latter having no superior influence, as is generally supposed.

In poisonous powders, London purple is rapidly taking the lead. It is largely used in the public parks and in government experimental farms, and is considered superior to Paris green on account of being more soluble, there being less danger of burning the foliage with it. It is said to go further, and is certainly much cheaper, which is accounted for by its being a by-product. When used as a powder, it also has the advantage of being more readily seen on the plants. The adulterants usually mixed with it are either land-plaster, road-dust, plaster-of-Paris, or cheap flour; and it is advisable to mix thoroughly at least twenty-four hours before use, which allows the adulterant to absorb the poison, making it more effectual. Where small areas only have to be gone over, flour is the best, as it adheres tenaciously to the foliage, and it is more inviting to the insectivorous appetite than minerals. When mixed with flour, one pound of London purple to twenty to thirty pounds

of flour is the proper proportion, according to the tenderness of the plants; mixed with land-plaster or plaster-of-Paris, one pound of the poison to a hundred and fifty pounds of the adulterant; with dry road-dust, one pound of the poison to a bushel and a half of the dust. In making liquid solutions, mix one pound of London purple with two hundred gallons of water, but first wet the powder and form a thin paste to prevent it from forming lumps. It should be put in the water twelve hours at least before use, for the best results. Paris green can be mixed in the same proportions, and in the same manner, as above.

WHITE'S STREET-RAILWAY RAIL AND CHAIR.

THE accompanying illustrations show an improved form of rail for street-railways, designed and manufactured by R. T. White of Boston. Fig. 1 shows the rail in section. Two pendant sides or girders are rolled integral with the top or tread of the rail, thus giving greater strength than the ordinary girder-rails having a central vertical rib. This rail has many advantages over the common form of tram or girder rails, being easier to lay and pave to;

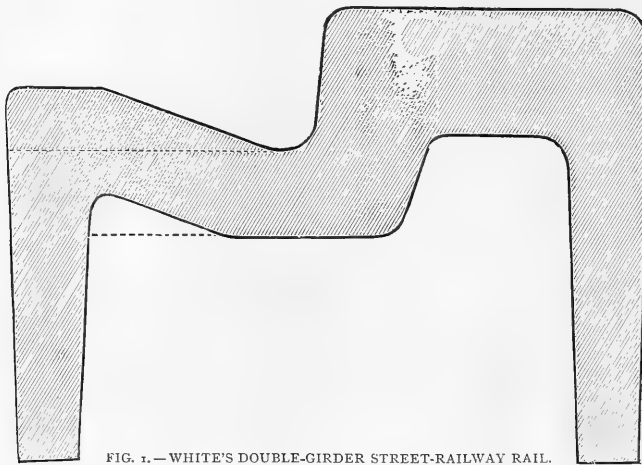

FIG. 1.—WHITE'S DOUBLE-GIRDER STREET-RAILWAY RAIL.

and the paving, on settling, cannot drop under the head and flange of the rail, — a very serious defect with the common form of girder-rails. The top or wearing part of this rail may be made as shown by the full or dotted lines; but, by making it as shown by the full lines, more wearing surface can be obtained on the head of the rail before the flange of the wheel touches the bottom of the groove. Carriage-wheels can easily pass over or out of this rail, and the groove cannot become clogged, as the flange of the car-wheel acts as a wedge as it passes along, forcing stones or dirt out of the way.

Fig. 2 shows the method of laying the new rail. It is secured on a chair by a bolt passing through the pendant sides of the rail and through the upper end of the chair. These chairs are placed at suitable intervals along the rails, and a similar chair of sufficient length is used at the ends, for connecting the rails together, thus making a substantial and practical joint. The chairs are set on and secured to wooden sleepers by lag screws, as shown; but the wooden sleepers may be dispensed with by enlarging the base of the chairs sufficiently to give them a solid bearing when tamped in the ground, or they may be set in concrete. In this case, tie-rods would be used to hold the rails to gauge.

FROM 1877 to 1888, forty-nine cases of leprosy have been treated at the St. Petersburg hospitals. About one-half of these are reported to be of subjects born in the city proper. Of the others, some come from the Baltic provinces, but there are also a few from districts where hitherto leprosy has been unknown.

ROYAL SOCIETY OF CANADA.

THE seventh annual meeting of the Royal Society of Canada took place in Ottawa on Tuesday, May 7. From the secretary's report, it seems that the delay in the appearance of the "Transactions of the Society" was caused by the incomplete nature of many of the papers. Four vacancies were filled during the year, — three in the English section, and one in the mathematical. In 1887 a committee was appointed to consider the proposition of taking steps in the direction of an imperial union of the services of similar societies, in connection with the Imperial Institute, to co-operate in developing and illustrating the resources of the empire. A favorable report having been returned, the committee was further instructed to communicate on the subject with the authorities of the Imperial Institute.

Delegates from affiliated societies were introduced, representing the Society of Canadian Literature, the Natural History Society, the Numismatical and Antiquarian Society, the Society for Historical Study, the Literature and History Society, the Geographical Society, the Quebec Institut Canadien, the Ottawa Institut Canadien, the Field Naturalist Club, the Entomological Society, the

Toronto Canadian Institute, and the Nova Scotia Historical Society.

Mr. Sandford Fleming, in his presidential address, touched on the fact, that, of the eighty original members, seven had passed away, and that the society had reason to congratulate itself upon the justification of all its elections. The address consisted mainly of an examination and inquiry into the origin of the two great races which form the Dominion. L'Abbé Casgrain followed with an address on the objects of the several sections. The scope of the papers may be gathered from the following partial list: "The Study of Political Science in Canada;" "Trade and Commerce in the Stone Ages;" "The Cartography of the Gulf of St. Lawrence;" "Nematophytin;" "De Marseilles à Oran, Souvenirs d'Afrique;" "L'Empereur Maximilian du Mexique;" "The Historical Influence of Physical Geography;" "Canadian Pre-Railway Transcontinental Journeys;" "Trilinear Co-ordinates on the Sphere, and Oblique Co-ordinates in Geometry of Three Dimensions;" "A Problem of Political Science;" "Papers on Higher Mathematics;" "The Ore Deposit of the Treadmill Mine, Alaska;" "The Microscopical Character of the said Ore;" "Fossil Sponges from Beds of the Quebec Group of Sir William Logan at Little Metis;" "Copper Deposits of the Sudbury District;" "Geography and Geology of the Big Bend of the Columbia."

On Wednesday evening a public meeting of the French section was held. Principal Grant addressed the audience on "Who are Canadians?" and L'Abbé Casgrain gave an oration on "The Death of Montcalm."

At a general meeting on Wednesday, and another on Thursday, it was resolved that the council elect four members for three years from the past membership of the council, in order to insure permanency; it was suggested that in future the meetings of the society be inaugurated by a conversazione; the question of extending the term of presidency from one to three or to five years was discussed, and deferred till next session; a committee was appointed to welcome, in the name of the society, the American Society of Mining Engineers in Ottawa in the autumn; a committee was nominated to meet the American Association for the Advancement of Science in Toronto; and the following officers for the ensuing year were elected: L'Abbé Casgrain, president; Principal Grant, vice-president; Dr. Bourinot, secretary; and Dr. Selwyn, treasurer.

Mr. Sandford Fleming entertained a select party of members at luncheon in the Rideau Club, and on Thursday afternoon the entire society was invited to a garden party at Government House.

ELECTRICAL NEWS.

Overhead Wires for Electric Railways.

THE rapidity with which electric street-railways have been introduced into towns and the suburbs of cities, and the success that has attended their introduction, have called the attention of the

system will probably work well on level lines, but can hardly be economically used when grades of four per cent and over are to be taken. The conduit system could possibly be made to work if enough money were spent on it, — \$50,000 or \$60,000 a mile, — but so far it has not been a success. In Boston it has not worked satisfactorily; and at San José, Cal., where it has been from time to time reported as successful, it has turned out a flat failure. In fact, for an extended system of street-railways, the only electric system which would be any thing more than an experiment is the overhead system. In Boston two lines have been in operation for some time; and they have worked so successfully, and have seemed so unobjectionable, that the Board of Aldermen has given permission to the West End Street Railway Company — a company operating all of the important street-railway lines in Boston — to equip their entire system with the overhead electric wires. There can be no doubt of the advantage that this will be to the public. It will allow rapid transit to the suburbs, and in the crowded portions of the town the cars will make much better time than is possible with horses; they will be under better control, and will occupy less space in the streets.

In fact, the question is getting to be, not shall we use electricity on our railroads, but what system shall we adopt? Shall we use the overhead, or shall we wait for a storage-battery? It is

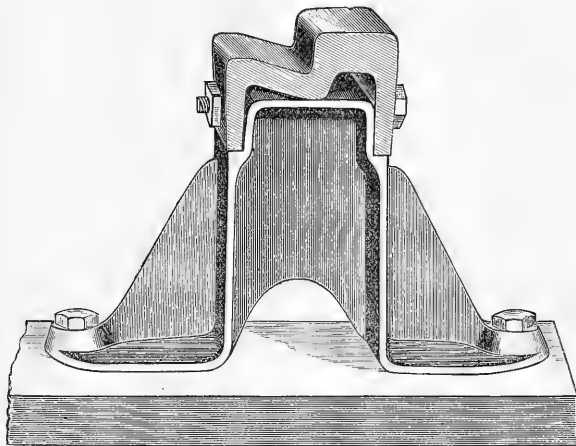

FIG. 2.—WHITE'S DOUBLE-GIRDER STREET-RAILWAY RAIL.

managers of the larger city lines to this method of traction. Its advantages are unquestionable: it is cheap, it is clean, it gives a rapid and easy service to the public, the cars are more readily and safely handled than by any other known method. There is one legitimate objection to it, and but one; and that is the necessity, except in special cases, of overhead wires to convey the electric current from the power-station to the cars. The public is prejudiced, and generally justly prejudiced, against overhead wires. Overhead wires mean to most of us a confused network of telegraph, telephone, and electric-light wires, unsightly and dangerous. But the wires used for electric railroads are very different from these. The poles used to support them are only slightly larger than the ordinary lamp-posts: they may be made even less objectionable. The line consists of a small span wire going from pole to pole, with the conducting wires supported by these, and extending over the track, one small wire for each track. An inspection of some of the latest and best-equipped electric roads shows a marked advance over those of a year or a year and a half ago. If expense is not spared, the most sightly of the present roads can be improved on, and two or three thousand dollars a mile is a small sum when a city road is to be equipped.

There are alternative electrical methods which do not involve an overhead structure, but they are not at the present time successful enough to warrant their general adoption. The storage-battery

probable that many of the managers will decide to put in the overhead system until the secondary battery is ready to take its place. The loss will not be very great, and two or three years' successful operation will more than pay for the change. The equipment of the Boston roads — if they are equipped — will give a decided impulse in this direction.

SOME EXPERIMENTS ON LIGHT AND ELECTRICITY.—The following is from the London *Electrician*: "An experiment described by M. J. Borgman has an important bearing upon the explanation of the remarkable discovery of M. Hallwachs, in which a beam of light seems to act as a conductor for an electric current. The latter experiment consisted in placing a piece of metallic gauze parallel with but insulated from a second sheet of metal. The first is connected with the positive, the second with the negative, pole of a battery, and in one of the leads a delicate galvanometer is placed. If, now, a beam of light be made to pass through the gauze, and to fall on the plate behind, a current is set up in the circuit, and continues to flow as long as the illumination is maintained. It has, moreover, been shown that the action is due to the ultra-violet waves. Now, M. Borgman wanted to ascertain whether or not the effect was instantaneous; that is to say, whether the commencement and the cessation of the current was or was not simultaneous with that of the illumination. M. Borgman probably reasoned, that, if the beam acted in some sense as a con-

ductor of the current, the effect must be instantaneous; while, if the phenomenon resulted from some secondary action, it would probably go on increasing up to a certain point with the duration of the illumination, and it would also probably continue for a time after the light had been cut off. His method of making the test was equally simple and ingenious. The light was interrupted at rapid intervals by means of a rotating disk with holes or slits, and he placed a telephone in circuit with the battery. It is, then, obvious, that, if the effect is instantaneous, the telephone will produce a note corresponding in pitch to the velocity of the disk; if otherwise, there will be silence. There was silence. A make and break in any other part of the circuit could be heard, but not in the beam of light; hence we must seek for some secondary action on the surface of the plates to explain M. Hallwach's experiments."

THE ELECTRO-CHEMICAL EQUIVALENT OF SILVER.—A very important electrical constant— one often used in the measurement of electric currents—is the amount of silver deposited in a given time by a given electric current. Determinations have been made by Kohlrausch, Rayleigh, and Mascart, the results of the last differing from those of the first two by as much as one part in four hundred. Recently Pellat and Potier have repeated the experiments, using to measure the currents an electro-dynamometer constructed by M. Pellat, and taking every precaution to insure accuracy. The result obtained gives 1.1192 milligrams of silver deposited in one ampère in a second. The previous results are, Kohlrausch, 1.1183; Rayleigh, 1.118; Mascart, 1.1156; Pellat and Potier, 1.1192. The mean is very near to Rayleigh's value.

THE VOLTAIC CURRENT OBTAINED WITH BISMUTH IN A MAGNETIC FIELD.—The following experiments are due to Dr. G. P. Grimaldi. A wide U-tube contained a solution of bismuth chloride in hydrochloric acid. In the two limbs of the tube dipped two wires of chemically pure bismuth very carefully polished. One limb of the tube was placed between the conical pole-pieces of a Faraday electro-magnet of medium size in such a way that the surface of the liquid was in the most intense part of the field. The two wires were joined up to a very sensitive Thomson astatic galvanometer. On closing the galvanometer circuit, a current was observed which at first varied rapidly, but which finally reached a permanent value. This was compensated by means of a shunt containing a standard element, and the galvanometer was brought back to zero. If then the electro-magnet was excited by a powerful current, a permanent deflection of the galvanometer was observed; if the magnetizing current was broken, the galvanometer returned to zero. The current produced by magnetism, which the author calls the galvano-magnetic current, is independent of the intensity and direction of the current first observed in closing the galvanometer circuit before the magnet circuit is made. The latter is variable; the former is always in the same direction,—in the galvanometer circuit, from the magnetized bismuth wire to the non-magnetized one; and in the liquid, from the non-magnetic metal to the magnetic one. The intensity of the galvano-magnetic current depends on the state of the surface of the metal, and to get regular results it is necessary to carefully polish the bismuth wires. To give an idea of the magnitude of the electro-motive force of the galvano-magnetic current, the author states that in the various experiments hitherto made under good conditions with various wires, and in various modifications, it has varied from $\frac{1}{100000}$ of a Daniell cell, the magnetic field being produced by a Faraday magnet of ordinary size, excited by a current of eight to twelve ampères, and with conical poles seven millimetres apart. With less powerful magnetizing currents, the results are smaller; and, with a current of two ampères, the galvano-magnetic current is scarcely appreciable. The direction of the galvano-magnetic current is independent of the direction of the field: its intensity sometimes varied a little when the field was reversed, and sometimes remained constant.

NOTES AND NEWS.

THE fourth annual meeting of the Science Club of the University of Kansas, Lawrence, was held Friday, May 17. The following is a list of the papers read: "Proximate Analysis of the Mountain Sage," by L. E. Sayre, John Scott, and E. Morris; "On

the Action of Various Organic Acids on Calomel," by E. H. S. Bailey and W. B. Hilton; "Blue-Printing," "Columns of Uniform Strength," and "Maximum Bending Moment in Beams and Arch-Ribs," by E. C. Murphy; "Notes on the *Lanidae*," and "Notes on Bird-Migration, Spring, 1889," by V. L. Kellogg; "On Some Corrections on the Thomson Calorimeter," by L. I. Blake; "Development of the *Luccinea* and the *Planorbias*," and "The Nervous System of Some Invertebrate Types," by Gertrude Croty; "The Psychology of Counting," and "A New System of Derived Units," by W. S. Franklin; "A Case of Atavism," by E. E. Slosson; "On the Quality of Commercial Potash and Soda," by George F. Weida; "Coals of Kansas," by E. H. S. Bailey and L. T. Smith; "Methods of Stating the Results in Water-Analysis," by E. C. Franklin; "The *Mallophaga*," by V. L. Kellogg; "The Mode of Respiration of Salamanders," and "Curve of Daily Mean Temperatures for Twenty-one Years," by F. H. Snow; and "Proximate Analysis of the Fruit of the Pawpaw (*Asimina triloba*)," by L. E. Sayre and B. L. Hill.

—At a recent meeting in New York of the American Institute of Mining Engineers, Mr. Oberlin Smith of Bridgeton, N. J., read a paper on the making of nails of good quality from tin-scrap. This process undertakes to use this material just as it is, without trying to separate its constituents at all, and to use it, moreover, for a purpose in which the qualities of both these constituents—namely, the tensile strength and ductility of the iron, and the resistance of the tin to corrosion—are directly employed with advantage. The nail was invented, in its original shape, by Mr. George H. Perkins of Philadelphia, and has been developed, through various forms, until it has almost reached a commercial stage, the machine in which it is to be made in marketable shape being nearly completed. Mr. Smith has been associated with Mr. Perkins in its development. The machine now under construction has been very much simplified, and made enormously strong and heavy. It is adapted to cutting, crushing, gripping, and heading the nails at one operation, and can be run as fast as an expert operator can feed the material. Its feed probably varies, with jagged, irregular scrap, from thirty to ninety nails per minute, although straight strips of sheet metal can be fed by hand into a machine running as high as 240 strokes per minute. During the course of their experiments, various forms of nails have been tried. Among others were straight cylindrical nails with conical points, straight square nails with pyramidal and with wedge-shaped points, hexagonal nails, etc. The most practical form seems to be the square taper nail with about the same shape as the ordinary cut nail, but is somewhat stronger and a good deal tougher. The economy of this system of nail-making is obvious. The scrap can be bought for about seventeen cents per hundred pounds, and a boy can make perhaps a hundred pounds of nails per day. The most economical system of manufacture will probably be to run one or more nail-machines at each large "tinshop," set as close as possible to the presses which produce the scrap, so as to avoid the expense of unnecessary handling, and the extra tangling-up incident thereto.

—The bearing of chemistry upon construction is thus illustrated by the *Lumber Trade Journal*: It is safe to say that no two varieties of wood possess the same essential chemical characteristics, and, the instant one possessing much alkali is placed near another that gives acid in its re-action, it will invite rapid dissolution and decay. What is true with reference to wood applies with all the force to the other materials used in structures. Two uprights, the main-stay of a quite large country bridge, rotted off at the ends when bolted together with an iron bolt. New ones were put in, and fastened by wooden pins of the same variety; and ten years have elapsed, and still they stand. In the first instance, beech, which is known to contain much acetate, was used, and the iron soon oxidized, transmitting the rot to the wood, and, though the rest was perfectly sound, the wood about the splice soon rotted off; while in the latter case the same wood from the same tree was used, but the wooden pins did not rust, and the joint remains firm and sound at this writing, and it is now nearly ten years since the renewal was made. Now, if a wood like ash or oak, having less acetate in its composition, had been used, instead of rotting or oxidizing, it would have tended to preserve the iron, hence would last

longer than if fastened with pins made of its own species of wood, or any, for that matter.

— Charles Lamb was possibly not far wrong, says *The Horological Journal*, when he conjectured that Adam had a sun-dial in Paradise. Dials are probably older even than alchemy. The Babylonians had them; though the Egyptians, that wondrous people who knew most of the things the moderns have rediscovered, seem not to have used them. The Babylonians gave them to the Greeks; the Greeks, to the Romans; and the Emperor Trajan is credited with an epigram upon the art of dialing. Naturally dials are most frequent in lands where the sun shines, as a matter of course, and not as a rare complacence. French and Italian gardens are full of them. To the walls of sunny *châteaux* they are fixed in hundreds. In the old days, when there was time for sentiment, and room for it, sun-dials were favorite gifts from great personages to one another,—from people to princes, and from princes to people. Cosmo de' Medici, whose fitful humors so angered Benvenuto Cellini, gave one to the Florentine students of astronomy; and on the wall of Sta. Maria Novella it still marks the time of day. But even in our own cold land of fibre and complexion there are dials not a few. In Mrs. Gatty's book some eight hundred inscriptions are set down; and, as some favorite legends are common to many dials, the recorded number is probably close upon a thousand.

— Mr. G. T. Shepley, the architect of the Leland Stanford, jun., University, states in the San Francisco *Building Advertiser* that the work on the large dormitory in connection with the university has been commenced. The buildings completed, or nearly so, number fourteen, and consist of lecture-rooms, reception-rooms, laboratories, and all the requisite departments for a complete educational course. The dormitory will be situated about a thousand feet from the other buildings. It will be 275 by 145, four stories high, presenting a very imposing structure. The material used is San José stone. The building will accommodate two hundred students. Single rooms will be 18 by 26, and double rooms 24 by 26. Altogether there will be from one hundred and twenty-five to one hundred and fifty rooms. There will only be one dining-room for the two hundred students, and this will occupy the central portion of the lower floor. The kitchen, laundries, etc., are in the basement; but, as the dining-room is raised considerably above the floor on which it is situated, there will be plenty of light and air afforded for the basement. All the fifteen buildings will be heated by steam and lighted by electricity from one central station placed in the rear of the quadrangle. The university will not resemble any of the Eastern universities to any great extent. All the old colleges are built around quadrangles, and in this one point the Leland Stanford, jun., University will resemble them, but in no other. There will be a magnificent view from all the sleeping-rooms of the dormitories.

— M. J. Violle has been investigating the alloy of the standard international kilogram, says *Nature*. The alloy of platinum and iridium in the proportion of ten per hundred, prepared with the greatest care by M. Matthey, is here found to be still somewhat defective. M. Violle's researches show that an alloy of nine parts platinum and one iridium yields more uniform and accurate results, both as regards density and specific heat. The density thus obtained is an absolute constant, incapable of further modification under cold hammering, annealing, or any other severe test.

— In the *Canadian Record of Science* for April, in a paper on the glaciation of eastern Canada, Robert Chalmers, of the Geological Survey of Canada, maintains that the investigations hitherto made in regard to the glaciation of eastern Canada show that instead of its having been caused by a continental ice-sheet moving over the region from north to south, as has been supposed, local glaciers upon the higher grounds, and icebergs or floating ice striating the lower coastal and estuarine tracts, during a period of submergence, were agents sufficiently powerful to produce all the phenomena observed. The latter theory, with some modifications, is the one so long maintained by Sir William Dawson, who has studied the glaciation of this country for forty years or more. A number of other observers have of late years been at work, however, and Sir William's views are now, Mr. Chalmers holds, about

to receive abundant confirmation. The large mass of new evidence obtained, and now available for co-ordination and study, is, however, so scattered through the reports of the Geological Survey and various scientific periodicals, as to be somewhat difficult of access. A good deal of unpublished material, too, relating to this subject, is now in the hands of the Geological Survey staff. The object in this paper, therefore, is simply to collect and correlate all the main facts within reach relating to this important question, briefly summarizing the results, and referring the student for fuller details to the reports and publications alluded to.

— The following recommendations are given by the Forestry Division of the Department of Agriculture in regard to the cheaper coatings for keeping moisture out of timber: Never apply paint or any other coating to green or unseasoned timber. If the wood was not well dried or seasoned, the coat will only hasten decay. Good coatings consist of oily or resinous substances which make a smooth coat capable of being uniformly applied. They must cover every part, must not crack, and possess a certain amount of plasticity after drying. Coal-tar, with or without sand or plaster, and pitch, especially if mixed with oil of turpentine and applied hot (thus penetrating more deeply), answers best. A mixture of three parts coal-tar and one part clean unsalted grease, to prevent the tar from drying until it has had time to fill the minute pores, is recommended. One barrel of coal-tar (three to four dollars per barrel) will cover three hundred posts. Wood-tar is not serviceable because it does not dry. Oil paints are next in value. Boiled linseed-oil, or any other drying vegetable oil, is used with lead or any other body, like powdered charcoal, which will give substance to it. Immersion in crude petroleum is also recommended. Charring of those parts which come in contact with the ground can be considered only as an imperfect preservative; and unless it is carefully done, and a considerable layer of charcoal is formed, the effect is often detrimental, as the process both weakens the timber and produces cracks, thus exposing the interior to ferments. Lastly, in communities where durable timber is scarce, it will pay to establish a plant for impregnating timber with antiseptics by the more costly process described in "Forestry Bulletin," No. 1.

— At Reinickendorf, a village near Berlin, it is reported by *Building*, a consumptive sanitarium is to be erected on a novel plan, utilizing the supposed therapeutic influence of association with certain animals. A large cylindrical building will be occupied in the upper part by the patients, while the ground floor will be given up to the accommodation of large numbers of milch cows, the exhalations from which will be conducted to the apartments above. A whey and buttermilk diet will also be contributed by the under boarders.

— The iridium anti-friction metal is now being introduced into England. This metal has undergone some very successful tests in America, Professor Thurston having compared the behavior of a brass made of this alloy with one of the Pennsylvania Railroad Company's standard phosphor-bronze bearings. The tests extended over eight hours, the mean speed of revolutions being 400 per minute. The pressure at starting on each brass was 200 pounds, which was increased by an additional 200 pounds at the end of every two hours. The behavior of the two alloys was, it is stated, practically identical. The iridium metal contains no iridium, the term apparently being used simply to indicate that the material is a hard alloy, though it has a low melting-point, and can be cast round journals in place in the same way as babbitt-metal. If desired, however, it can be cast and machined in the same way as ordinary gun-metal.

— A generous gift of \$150,000 was made recently, says *The American Geologist*, to the University of Minnesota by Ex-Governor and Regent John S. Pillsbury of Minneapolis. It was conditioned only on the pledge by the Legislature that the university should not be weakened by the division of the funds that now constitute its endowment, but that the so-called agricultural land grant (under the law of Congress of 1861) should remain inseparably connected with the university proper. This pledge the Legislature gave. The gift will be used, as intended, to complete and furnish the new Science Hall. At the university of California the

Lick Astronomical Observatory was the result of a large private donation. At Madison, Wis., the Washburn Observatory was largely the gift of the citizen whose name it bears, and citizens of Michigan erected and furnished the Detroit Observatory at the University of Michigan. The donation of Gov. Pillsbury, however, seems to be the first of importance to a State university in behalf of what are generally known as natural sciences.

— A correspondent of the *Revue Scientifique* vouches for the following story: For about twenty years he was in the habit of visiting two or three times each year a farm where was kept a flock of geese, numbering from thirty to thirty-five in the early part of the winter, and in the spring four or five, left for breeding purposes; these also generally being killed a few months later, after the new broods had attained their growth. In the month of July, 1862, on a feast day, the farmer and his men being absent, the geese were forgotten, and were attacked by dogs, which killed the most of them. The next evening at twilight the farmer thought they must have been attacked a second time. He found them flying about in their pen, much frightened, but the dogs were nowhere to be seen. The next day this terror re-appeared at the same hour, as it did on the following day and from that time on. The correspondent of the *Revue* had forgotten this fact, when, ten years later, he chanced to be on the farm one evening, and heard the cackling of the apparently frightened geese. When he asked for an explanation, he was told that this had been kept up from the time they had been attacked by the dogs, that there had been no repetition of the attack, and that the flock had been renewed in the mean time at least three times. If this story is well authenticated, we have a case of the transmission of terror to the third generation in a family of geese.

— Loss and gain of nitrogen, M. P. P. Dehérain has determined by the experiments carried on at Grignon from 1875 to 1889, according to *Nature*. A general survey of the results of these experiments leads to the conclusion that all soils containing considerable quantities of nitrogen in combination, say two grams to the kilogram, lose, if cultivated without manure, far more nitrogen than is absorbed by the crops, but in proportions varying according to the nature of those crops, — more with beet root, less with maize grown for fodder, still less with potatoes and wheat. But when the ground has thus been impoverished, no longer containing more than 1.45 or 1.50 grams to the kilogram, the loss ceases, and the ground begins, on the contrary, to recover a certain proportion of nitrogen, the gain being much greater on grass-grown than on tilled lands.

— The Swiss Federal Council has invited the European governments to be present at a conference to be held in Berne next September. The object of the conference is international legislation in regard to labor. The council suggests the following points for the consideration of the conference: the prohibition of labor on Sunday, or at least rest on one day out of seven; a fixed minimum age for the admission of children into factories; the maximum length of a day's labor for young working-people; the prohibition of the employment of young men and women in pursuits especially injurious to the health or dangerous; and the restriction of night-work for young men and for women.

— To-morrow the first working detachment of the Nicaragua Canal Company will leave this port for Greytown. The party is in charge of Lieut. Usher, United States Navy. A large number of friends interested in the success of the enterprise has been invited to accompany the expedition down the bay to wish it *bon voyage*.

— It is proposed to hold an international novelties exhibition in the Great Central Hall, London, commencing May 29. The exhibition, according to the prospectus, has been undertaken for the purpose of introducing and bringing before the public the many meritorious novelties in the arts, sciences, and manufactures which have been invented and produced in recent years, not alone in Great Britain, but also on the Continent and in the United States. The Central Hall contains 26,000 superficial feet floor-space, and is situated in the very heart of London. The hall is lavishly decorated, and has been designed with special attention to the re-

quirements of an exhibition. Of the space at the disposal of the executive, 5,000 superficial feet have been guaranteed to the commissioners representing the exhibition abroad, who are now selecting the most recent and eligible inventions and novelties produced in their respective countries. A certificate has been obtained from the Board of Trade, protecting any unregistered patents and designs which may be shown at the exhibition.

— A new adulteration of coffee has been recently discovered in Germany. M. Stutzer of Bonn states that this artificial coffee is made from burnt farina, afterwards agglutinated by the aid of dextrine or some similar substance. In Cologne there are two factories which turn out these coffee-beans.

— The fourteenth annual meeting of the American Association of Nurserymen will be held in Chicago on June 5 and 6. The programme shows that addresses on an unusually wide range of topics may be expected from speakers well qualified to give instruction. These meetings have proved of great value, both from an educational and from a business point of view, and the nurseryman who neglects to attend them fails to live up to his privileges.

— Engelmann of Leipzig has undertaken the republication of a number of classical memoirs under the editorship of Professor W. Ostwald of Leipzig. The first memoir is the well-known paper of Helmholtz on "The Conservation of Energy," first published in 1847. Other memoirs of Jauss and of Dalton will follow at an early date. The title of the series is "Die classiker der exacten Wissenschaften."

— The Council of the Geological Society of America recently held a meeting at Washington, according to *The American Geologist*. Nominations for fellowship were made to the society of about fifty candidates, all of whom had expressed a desire for election. Professor C. H. Hitchcock was designated to make arrangements for an excursion from Toronto, and another attempt is likely to be made in favor of the Huronian region. He was instructed to correspond with the local committee at Toronto, and with the officers of the Canadian Survey. The programme of the meetings of the society at Toronto was ordered to be independent of that of the association. The committee on revising the constitution held a meeting, and decided on several important matters relating to the constitution. The committee on plan of publication, through Mr. W. J. McGee, secretary, made a voluminous report embodying facts concerning the manner and success of publications by various leading scientific societies in Europe and America. This committee will render a final report, making recommendations of its conclusions to the council at its next session, probably at Toronto.

— Work has just begun on a new building for the Massachusetts Institute of Technology, Boston. The building, which is to include five stories and a basement, will measure 148 by 50 feet, being built of brick with sandstone trimmings. It will be designed after the order of mill-construction, and will cost about \$70,000. The basement and the greater part of the first two floors are to be occupied by the department of mechanical engineering. Cotton machinery, hydraulic testing-machines, shafting tests, and testing-machines for the strength of materials, are to be put in here. The light-running machinery is to be located on the second floor, and above this the department of civil engineering is to be situated. The new building will probably be completed about the first of next winter.

— According to an English provincial paper, a Mr. Cash, a board schoolmaster, and Mr. Pringle, a solicitor, were out photographing, and a plate was exposed on a river-view near Ipswich. When the plate was developed, "there was plainly revealed, in the foreground of the picture, the figure of a woman apparently floating upright in the water, as it is declared that drowned bodies sometimes will, after immersion for a certain length of time. The face and head are clearly outlined; the arms are hanging straight by the side of the body, which is clad in ordinary female attire, and is visible to the waist; and the portrait generally appears to be that of a tall and comely young woman." The schoolmaster and solicitor, apparently thinking there was some peculiar phantom in the river invisible to the eye, but able to impress the plate, took a chief

of police into their council, and the collective wisdom of the three took the form of trying to capture the phantom by dragging the river. In commenting on this, *The Photographic News* expresses the opinion that possibly by this time Messrs. Cash, Pringle, and the chief of police have learned that phantom images on gelatine plates are not extremely rare, as a minute hole in a drying-cup-board or box will often cast an image on a plate. Again, such phantom images occasionally arise from a minute hole in the camera, plate-box, or even the dark slide. Most likely a little inquiry will serve to identify the original of the phantom portrait.

—At a late meeting of the Minnesota Academy of Natural Sciences, Mr. A. D. Meads of the Minnesota Geological Survey read a description of the Stillwater (Minn.) deep well, we learn from *The American Geologist*. It was begun in June, 1888; and the work has continued, with little interruption, up to the present time, when the depth has reached about 3,400 feet. Gas, probably local accumulations of marsh-gas along the shore of Lake St. Croix, led to the drilling; but a spirit of laudable curiosity to know what is below the city, on the part of several of the citizens who pay the costs, has taken the place largely of all expectations of finding gas, and is now the principal motive for continuing the work. The well starts at about 740 feet above the sea, and after passing through 701 feet of drift, white, friable sandstone, and green shales, belonging to the St. Croix and so-called Potsdam of the North-west, enters a series of dark-red and brown shales and brown felspathic sandstones, which exhibited a thickness of more than 1,500 feet. These gradually assume the characters of a volcanic detrital tuff,—"amygdaloidal," calcitic, kaolinic, still brown, slightly silicious,—and finally, at the depth of about 3,300 feet, unmistakable beds of trap-rock were encountered, alternating with sandstone beds. At this depth some grains of native copper were seen in the drillings. Water was found in the sandstones near the top of the drill, and down to the depth of about 740 feet. Small quantities of salt water were obtained at about 1,950 feet, and at the depth of 2,250 feet a small amount of gas was said to have been noted in connection with another stratum giving brine. Mr. Meads's main conclusions were as follows: 1. The Stillwater well is wholly below the Trenton limestone. 2. From 717 feet to the bottom of the well is Keweenaw. This thins out or runs deeper toward the south, not appearing at the depth of 1,160 feet at Hastings. 3. The Keweenaw rocks at Stillwater are almost identical with those at Keweenaw Point. 4. The well may be of some value as a source of water-supply; but as a source of gas the prospects are poor—or we might say there are no prospects whatever. 5. The well is of great value to geologists, as it fixes the place of the Keweenaw below the light-colored sandstones of the North-west, and hence effectually removes them from the mesozoic age. In several places the brown shales and sandstones that here are shown to overlie the traps, have been pierced by wells in Minnesota, but not penetrated, and hence the question was left open as to the age of the traps. This question is, therefore, no longer a debatable one.

—Mr. Robert Damon of Weymouth, England, the well-known naturalist and geologist, died suddenly on Saturday, May 4, from heart-disease.

—The following resolution of the government of Bombay, which has just been published, tells its own story, and, as *Nature* believes, adds another to the already numerous examples of the well-judged munificence of the Parsee community of Bombay. The resolution is entitled "Scientific Medical Research." "(1) The sum of Rs. 75,000 having been placed at the disposal of his Excellency the Governor by Mr. Framjee Dinshaw Petit, for the purpose of erecting and fitting a laboratory for scientific medical research, on a site which has been approved by the donor in the immediate vicinity of the Grant Medical College, the governor in council has much pleasure in accepting the offer, and, in doing so, desires publicly to thank Mr. Framjee Dinshaw Petit for his munificence in supplying an institution the want of which has long been felt by those most interested in promoting the cause of higher medical education in this presidency; (2) the governor in council is pleased to direct that the institution shall be called 'The Framjee Dinshaw Petit Laboratory for Scientific Research; (3) instructions for the

preparation of the necessary plans and estimates for the proposed building have already been given."

—Last winter the Vienna Medical School was attended by one hundred and fifty British and American medical graduates, among whom were many Edinburgh men. As many medical students, on their arrival at Vienna, do not know German, the Vienna *Weekly News* has opened a special "medical inquiry office" near the hospital, where information as to lectures, lodgings, etc., is given without charge to British and American medical men. The same journal publishes weekly a list of forthcoming courses of lectures at the Universities of Vienna and Berlin.

—At the Academy of Sciences, April 29, we learn from *Nature*, M. G. Lippmann read a paper on "A Means of Obtaining Photographs of True Chromatic Value by the Use of Colored Glasses." By the judicious employment of green, yellow, and red glass in the way he explained, excellent results have been obtained even with present plates, notwithstanding their greater sensitiveness to blue. The impressions are described as clear, and free from brown patches; the green foliage, the red or yellow draperies, instead of yielding brown tints, being reproduced in delicately modelled design, as in a well-executed engraving.

—The British consul-general at Patras, in his report for the past year, referring to the Corinth Canal, says that the managing committee has decided to defer payment of interest due to the shareholders. The canal was to be completed within 1888, at a cost of 30,000,000 francs; but this is not possible before 1891, at a cost of double the estimated expenditure. The canal is nine-tenths of a mile in length. According to the original plan, it was reckoned that 8,000,000 cubic metres of earth should be extracted at the cost mentioned, which included 5 per cent interest per annum to shareholders. A committee having been appointed by the government to inquire into the difficulties which have arisen, it was informed that the period for completing this work should be extended, and that the angles of slope should be reduced, and the sides protected by walls to prevent any earth-slips. On account of these alterations, the period for completing the work is extended to November, 1891, the amount of cubic metres of earth to be extracted is increased to 10,000,000, and the cost to 60,000,000 francs.

—According to the latest educational report of 1884, only 1,466,913 of the 15,000,000 children in the Russian Empire attended schools. About 90 per cent, therefore, of young Russia receive no instruction at all. In 60 governments there is only one school for secondary instruction to every 18,000 boys and 22,000 girls. Only 63 per cent of the boys of an age to attend a public high school can be accommodated. For girls, the number of such schools is even more insignificant. The schoolmaster cannot be said to be abroad in Russia yet.

—A novel idea has been put into execution in the machinery hall of the Paris Exhibition, with a view of facilitating the circulation of visitors in the vast building. Two travelling platforms sixty feet long, and capable of carrying ten tons each, are mounted upon the latticed iron girders that connect the columns carrying the shafting. Visitors will be admitted on payment to these platforms, which will be caused to traverse up and down the machinery hall by electric transmission. Access to the platforms will be obtained by elevators placed at each end of the machinery hall.

—The committee appointed to arrange the meeting of the International Congress of Geologists for 1891, according to *The American Geologist*, met in Washington April 20, and elected the following officers: permanent chairman, Professor J. S. Newberry; vice-chairman, G. K. Gilbert; secretary, H. S. Williams. The committee also added to its number the following gentlemen: Dr. T. Sterry Hunt, Professor E. D. Cope, and Dr. Persifor Frazer. Provision was made for three sub-committees,—(1) on the scientific programme of the congress, (2) on excursions, and (3) on arrangements in Philadelphia. The committee adjourned to meet at Philadelphia in November at the time of meeting of the National Academy. A majority of the committee were present at the Washington meeting.

SCIENCE:

A WEEKLY NEWSPAPER OF ALL THE ARTS AND SCIENCES.

PUBLISHED BY

N. D. C. HODGES,

47 LAFAYETTE PLACE, NEW YORK.

SUBSCRIPTIONS.—United States and Canada.....		\$3.50 a year.
Great Britain and Europe.....		4.50 a year.
Science Club-rates for the United States and Canada (in one remittance):		
1	subscription 1 year.....	\$ 3.50
2	" 1 year.....	6.00
3	" 1 year.....	8.00
4	" 1 year.....	10.00

Communications will be welcomed from any quarter. Rejected manuscripts will be returned to the authors only when the requisite amount of postage accompanies the manuscript. Whatever is intended for insertion must be authenticated by the name and address of the writer; not necessarily for publication, but as a guaranty of good faith. We do not hold ourselves responsible for any view or opinions expressed in the communications of our correspondents.

VOL. XIII. NEW YORK, MAY 24, 1889. No. 329.

CONTENTS:

THE DAFT ELECTRIC ROAD IN CINNATI.....	391	NOTES AND NEWS.....	398
INSECTICIDES AND THEIR APPLICATION.....	393	READING AS A MEANS OF TEACHING LANGUAGE TO THE DEAF	
WHITE'S STREET-RAILWAY RAIL AND CHAIR.....	396	<i>A. Graham Bell</i>	402
ROYAL SOCIETY OF CANADA.....	396	EXPLORATIONS OF CAPT. BINGER....	404
ELECTRICAL NEWS.		GUSTAVE EIFFEL.....	406
Overhead Wires for Electric Railways.....	397	MENTAL SCIENCE.	
Some Experiments on Light and Electricity.....	397	Psychic Cures.....	406
The Electro-Chemical Equivalent of Silver.....	398	BOOK-REVIEWS.	
The Voltaic Current obtained with Bismuth in a Magnetic Field....	398	The Primitive Family in its Origin and Development.....	407
		Hygienic Physiology.....	408
		A Hand-Book of Cryptogamic Botany.....	408
		Outlines of Lessons in Botany....	408
		AMONG THE PUBLISHERS.....	408

READING AS A MEANS OF TEACHING LANGUAGE TO THE DEAF.¹

"I would have a deaf child read books in order to learn the language, instead of learning the language in order to read books."

It delights me to observe in America a gradual change from the scholastic method of teaching language to that which has been so properly called by Mr. Scott Hutton the "natural method." But there is one point in the natural method to which I would direct your attention.

When we study the methods by which languages are naturally acquired by hearing children, we observe that comprehension of the language always precedes a child's attempt to express ideas in that language,—he understands the language before he uses it; whereas, in our attempts to apply the natural method to the deaf, we try to make the child use the language before he understands it.

I was very much struck by the remark of Mr. Job Williams, that it is practice, practice, practice, that gives a perfect command of language; that it is the frequency of repetition of words that impresses them upon the memory. Now, what sort of repetition do we give to the hearing child? Will any member of this conference make the experiment? It is an interesting one. Take a book in-

¹ An address delivered before the sixth national conference of superintendents and principals of institutions for the deaf (Gallaudet meeting), held at the Mississippi Institution, Jackson, Miss., April 14-17, 1888, by Alexander Graham Bell.

tended for children's use, and read it aloud. Test the speed of your reading, and you will find that two hundred words a minute is not a rapid rate.

A stenographer would say that one hundred and fifty words a minute is above the average rate of public speaking; but this is for language in which long words are of frequent occurrence, and where a deliberateness of utterance is employed that is uncommon in talking to children. Not only do short words predominate in our conversation with children, but mothers and nurses gabble at such express speed that a stenographer would probably give up in despair the attempt to transcribe the conversation. I am convinced from experiment that the average rate of nursery gossip exceeds two hundred words a minute. However, to be well within the mark, let us assume one hundred and fifty words as the average rate, and calculate upon this supposition the number of words-presented to the ears of a hearing child in the course of a day. Let us suppose that if these words were concentrated into one continuous talk, without any pause, it would amount to a speech of four hours in length, and surely this is not an excessive assumption. One hundred and fifty words a minute amounts to nine thousand words an hour, or thirty-six thousand words in four hours. This means that we shower at the ears of the hearing child no less than thirty-six thousand words a day; and, as the whole vocabulary we use in talking to children hardly exceeds three hundred words, this means a very great daily repetition.

We not only talk to a child at the rate of thirty-six thousand words a day, but we do this for three hundred and sixty-five days in the year (we do not stop on Sundays); and we do this for two years at least before we expect the child to turn round and talk to us. If, then, we attempt to apply to the deaf the natural method of learning language, what sort of repetition of words to the eye should we give the deaf child before we exact from him any great efforts at English composition? In the natural method of learning language, *comprehension always precedes expression*. But in our schools for the deaf this process is generally reversed. For example: in our sign-institutions a story is told in signs, and pupils who know little or nothing of the English language are required to go through the drudgery of writing out the story in words. Would not the converse process be more natural and profitable? Even in schools where the sign-language is not employed, action-writing is largely resorted to. For example: a teacher will take a book from a pupil, open it, pretend to read it, then close it and lay it upon the table. She then asks her class to express in English words what she has done.

While this plan furnishes an admirable exercise in composition for older pupils, it is surely out of place with pupils who cannot understandingly read an ordinary book. It reverses the process of nature, which demands that comprehension shall precede expression; that a *child must understand a language before he uses it*.

Now, we know perfectly well that if we can repeat words to the eyes of deaf children with any thing like the frequency and clearness with which we present them to the ears of the hearing, the deaf will come to master the language by the same natural process that produces comprehension in the hearing child. The great difficulty is how to do this. The speed of writing, even at a scribble, hardly exceeds thirty words a minute. The speed of the manual alphabet can be made to approximate one hundred words a minute, but very few teachers exceed an average speed of eighty words per minute. It is obvious, then, that the teacher cannot, by his own exertions, even approximate to the speed of speech.

Is there no hope, then, for the deaf child? Must the acquisition of English always be to him a long and laborious task? Must he acquire imperfectly, after years of labor, a language which is mastered by the hearing infant before he is four years of age, and which foreigners, commencing at the age when the deaf child enters school, acquire in a few months? I do not think so. I think that there is hope for the deaf child by the adoption of a plan that can be ingrafted on any system of instruction.

Though the speed at which we write is limited to about thirty words a minute, the speed at which we read is very different, especially when the words are presented in print so that the letters are clear and unambiguous. I gave an interesting novel the other

day to a friend, and noted the time when the reading began, and also the time when the book was closed. I then made a calculation of the number of words read, and I found that *more words had been read in an hour and a half than a hearing child hears in the course of a day.*

Other experiments have convinced me that the speed of silent reading, at least for those who know the language, averages from three hundred to even four hundred words a minute. I say, then, there is hope for the deaf, by putting books before them and accustoming them to form the habit of reading.

I would urge upon all superintendents and principals of schools for the deaf the importance of introducing reading as a regular school exercise, for the purpose of teaching language. I would introduce into the very youngest classes the practice of reading, *regardless of the fact that the children may not understand the meaning of the words on the printed page before them.* By this practice a repetition of words to the eye would be secured, which could not probably be obtained in any other way, and reading would co-operate with the regular instruction of the schoolroom to bring about a gradual comprehension of language.

I would place in the hands of the youngest pupils, in printed form, the stories that hearing children love to hear, and require them to read those stories, whether they understand them or not, without giving them any explanation of the meaning. Then, after their allotted task is completed, I would give them a reward.

I would show them a picture, or act the story out in natural pantomime. I do not hold, with many of my friends, that signs have not their use. I believe that signs, like pictures, are capable of being used so as actually to facilitate the acquisition of our language by the deaf. *The proper use of signs is to illustrate language, not to take its place.*

I do not know, however, if you will applaud me when I say that I do not here allude to the sign-language. There is the same distinction between pantomime and the sign-language that there is between pictures and the Egyptian hieroglyphics. Egyptian hieroglyphics consist of abbreviated conventionalized pictures, just as the sign-language consists of abbreviated conventionalized pantomime. No one will deny that the exhibition of a picture may add interest to the story that we tell a child. It illustrates the language, and it may be of invaluable assistance to him in realizing our meaning; but is that any reason why we should teach him English through Egyptian hieroglyphics?

The moment you teach one language through another, the pupil thinks in the language of communication, and acquires the other as a foreign tongue, just as the hearing children in our public schools continue to think exclusively in English, however many languages may be included in their curriculum of studies. The natural method demands that you shall teach a language *by using it for the communication of thought without translation into any other tongue.* If you want your child to learn German or French, the English language is an obstacle in the way, and retards his mastery of the foreign tongue, just as the use of the sign-language in our institutions retards the acquisition of English. If you send your child to Germany or France, or so surround him with German or French speaking people that communication is carried on exclusively in one or the other of these languages, he acquires the French or German as a native tongue.

I have no doubt that all things have a use, and even the sign-language may have a use in missionary work among the adult deaf; but I do not think it should have a place in the school, or be used in the instruction of the young, for it comes between the deaf child's mind and the English language he is striving to master.

If words are impressed upon the memory by frequency of repetition, then *the duller a pupil is, the more necessary is that repetition, and the more harmful the sign-language.*

But I am wandering from the subject. If we make a deaf child, perforce, as a regular school exercise, read, not a few paragraphs, but pages upon pages of a book, he will obtain that repetition to the eye which the teacher cannot give him by writing or by the manual alphabet. Let the pupil spend half an hour or an hour a day in reading (or spelling upon his fingers) the language that describes a fascinating tale. Do not show him a picture, do not

make him a sign, do not give him any explanation of the meaning until he has finished his allotted task. Then let the story be acted out, and let pictures be freely used, till he gets the meaning, not necessarily of the individual words and phrases, but of the story as a whole. He learns thus that the printed language in the book expresses a pantomime, or a series of pictures; that it represents, indeed, a narrative that absorbs and fascinates him.

Now, when he is called upon to go through his next daily task, he knows that the language expresses a story of some kind that will interest him, and all the time he is reading or spelling his mind is being exercised. Curiosity compels him to speculate, and he wonders what sort of a pantomime will be acted out, what sort of pictures will be shown him. *He frames in his mind an hypothetical story, which may or may not be right, but the pantomime or pictures will ultimately correct it. He is deriving ideas of some sort directly from the printed words.* This is the sort of exercise that the child needs. This is the kind of mental operation that goes on in the mind of the hearing child when he sits on his father's knee, and listens to the story of adventure or to the fairy-tale. In both cases the comprehension of the language is imperfect; in both cases errors are corrected and interest aroused by the exhibition of pictures, or by the use of dramatic gestures and natural pantomime.

I therefore strongly recommend the introduction of reading as a school exercise,—the introduction of interesting stories expressed in ordinary language, idiomatic phrases and all, not language stilted in expression, containing sentences exclusively arranged upon simple grammatical models. If the pupil is to make progress in his knowledge of ordinary language, the language must be above him, and not degraded to an unnatural level. Teachers may say, "Why use idiomatic phrases that cannot possibly be explained to the deaf child?" But he never can come to understand them until he has seen them, any more than the hearing child can understand them until he has heard them. The hearing child learns to understand by hearing, and the deaf child will come to know by seeing. Frequency of repetition will impress the idiomatic phrases on his mind, and much reading will bring about this frequent repetition in ever-varying contexts.

I may allude here to an experiment that I made upon myself, which has an important bearing on this whole subject. I obtained a work upon the education of the deaf, written in the Spanish language (of which language I knew nothing). I determined to ascertain how far I would come to understand the language by forcing myself to read the book. I read very carefully thirty or forty pages, and could make but little of it. The Latin roots helped a little, and I understood a few technical words here and there, but that was all. I refused at first the aid of a dictionary for a dictionary stops the current of thought. I read thirty or forty pages, and then paused.

Now, a number of words had occurred so frequently that I remembered them, though I knew not their meaning. These words I sought in the dictionary, and then I resumed my reading. I found that these words formed the key to the next thirty or forty pages, and that the meaning of many expressions that would otherwise have been obscure became manifest. New words also explained themselves by the context.

Every now and then, after reading a few pages, I resorted to the dictionary, and sought the meaning of those unknown words that I could remember without looking at the book. I then turned back to the beginning and read the whole a second time, and I was delighted to find that a very great portion of the meaning of that book revealed itself to me. Indeed, I felt convinced, that, if I wanted to comprehend the Spanish language, all I had to do was to read, and read, and read, and I should come to understand it.

The application of the deaf is obvious. The methodical instruction in the schoolroom, and the efforts of the teacher, take the place of the dictionary to the deaf child, and reading, reading, reading, with a desire to understand, will give that frequency of repetition to the eye that is essential to the mastery of language. To express the theory in a single sentence, *I would have a deaf child read books in order to learn the language, instead of learning the language in order to read books.*

Now, the books that are best fitted for this end are not those which are most commonly found in school libraries intended for the use of deaf children. We may be guided in our choice by the age of the child. We should place in the hands of the child such books as are of absorbing interest to hearing children of his age. If we wish the child to learn language, quantity of reading is more important than quality. For little children, such stories as "Jack the Giant-Killer," "The Three Bears," "Cinderella," and all the host of fairy-stories that so fascinated us when we were children, will be the best. For boys of twelve and thirteen I am afraid that the so-called "blood and thunder" novels would teach more language than "Stanley's Travels in Central Africa," or the best text-books of history. It is not necessary, however, to place in the hands of deaf children books of doubtful character, in order to give them reading of absorbing interest, while the press of this country continues to furnish such fascinating, entertaining, and at the same time elevating and improving literature for the young as has been prepared for them by such writers as Louisa Alcott, Elijah Kellogg, Margaret Sangster, and the scores of other authors of juvenile books of our time. A plentiful supply of interesting tales should be provided, sufficiently short to be read through at a single sitting, and of a character that could be illustrated by pictures and natural pantomime. Of course, suitable selection must be made of subjects; but I cannot too strongly impress upon you my conviction, that, for *language-teaching, mere quantity of reading is more important than quality*. For advanced pupils, the society novels and plays that are usually banished from the libraries of our institutions are what are wanted, especially those society novels that are written in conversational style, and abound in questions and answers. Ordinary books of history and travel are too often written in what may be called "book language," and not in the language of the people. But in novels and plays will be found the language of conversation, and these also are the books that will stimulate the pupil to read.

As your pupils become familiar with the printed page, they will take in words by the eye with greater and greater rapidity, until ultimately a speed of reading will be obtained of from three hundred to four hundred words a minute. Think what this means if the child reads for only an hour a day during the whole period of his school course! Think, too, of what value the habit of persistent reading will be to your pupils in adult life!

I believe, that, in the acquisition of language by the deaf, reading will perform the function that hearing does for the ordinary child. I do not think that any more important habit can be formed by the pupil than the habit of reading; for, after all, the utmost that you can do for his education in his school life is to introduce him to the wider literature of the world.

EXPLORATIONS OF CAPT. BINGER.

MORE than two years have passed since a marine officer set sail from Bordeaux (Feb. 20, 1887), destined to become renowned as a great explorer. After having for some time conscientiously studied the customs and the language of the people living about the Senegal, Capt. Binger returned to France, harboring the plan which he is about to execute.

His numerous studies and careful researches culminated in the following plan: to fill the large blank space which on our charts is situated in the bend of the Niger; and to connect the investigations and surveys made on the right bank of the river by French officers, and previously by the French explorer René Caillé, with those of Barth and with the surveys of the lower course of the Niger.

His first objective point was to be the city of Kong, the situation of which is approximately given on all our maps. According to one authority, it was said to be a great market-place, a place of meeting for caravans, and a centre of trade; while, according to other authorities, its existence was a matter of doubt, as this name of "Kong" ("mountain") was said to denote merely the watershed between the Atlantic Ocean and the Gulf of Guinea. The plan once conceived, Capt. Binger, on account of his indomitable energy and his perfect health, was the right man to carry it through, in the face of serious dangers. It required a march into unknown

regions. He was to be the first white man seen by the natives of that region; and his knowledge of the native tongue, spoken on the banks of the Senegal and the upper Niger, was of no use to him when once he had entered the unknown territory, as the language in the region to be traversed differs from that spoken throughout the French possessions.

On the 15th of May, Capt. Binger passed the post at Kayes on his way to Bamako, whence he was to start. From this point, in the beginning of June, he addressed a letter to the *almamy* ("chief") Samory, — the same who, by the treaty of March 23, 1887, had placed his states under French protection, — informing him of his intention to march into his country. The *almamy* pleaded that the war with King Tiébe, his powerful neighbor to the east, and the unfortunate condition of his country, would not permit him to receive the traveller, and refused to receive him. After a short time, however, he changed his mind; and, hoping to turn the chances of war in his favor, he wrote to Col. Gallieni, governor of Senegambia, asking him to send a re-enforcement of thirty soldiers from the colony. This request decided Capt. Binger to march on. He only wanted a pretext for doing so, and hoped he would be able to study the position of King Samory, and report to the commander of the French Sudan.

In the war mentioned above, Capt. Binger had tried to act as mediator. He settled upon the 30th of September as the date of his departure, but Samory interfered. First, his son, Karamoko, warned Capt. Binger that the roads leading to Kong and Tegrera were not safe, that it would be preferable to wait, and adduced many other reasons to induce him to give up his plans.

When Capt. Binger insisted upon his departure, Samory declared that he would not let him depart until he had taken Sikasso and several other cities in the neighborhood of Kong. This answer did not satisfy Capt. Binger; and therefore he demanded a final answer from Samory as to whether or not he would give him permission to traverse his country; but again no definite answer, and pretexts without end were the only result. Tired of these performances, Capt. Binger decided to move on as soon as practicable, and run the risk of Samory's hostility; but his energy and his firmness had been effective. He soon after received a confidential visit from the king and his son, begging him not to forget them, and to bring them some cartridges on his return.

The return to Benokubugula was effected by way of Saniema and Komina. Here, again, Capt. Binger found traces of the ravages of war. Komina, which some years before consisted of seventeen villages, — a much-frequented centre of almost four thousand inhabitants, — was nothing but a ruin. A few lemon-trees bore fruit as an emblem of former prosperity. "Since the *almamy* has come here," said a native to the captain, "the land is lost; the soil was good; one mule cost *ba unoro* ('fifteen francs'); now we can barely find enough to eat."

On the 7th of October, Capt. Binger re-entered Benokubugula, tired out, but still in good spirits. With the exception of the information gained as to the position of the *almamy*, his journey had been void of results.

After resting for several days, Capt. Binger resumed his march on the 16th of October, but not without having to overcome the same obstacles he had met with at Wolosebugu and Sikasso, — that of being unnecessarily detained. Near Tengrera, threatened by the inhabitants with the loss of his head if he proceeded farther, he was deserted by his escort, and at Furu — the boundary of the lands of Samory — he had to pay heavily for the permission to cross. At last he entered the dominions of Tiébe, accompanied by a guide and two men from Niele, captives of Pegue, chief of this part of Follona.

The captain first crossed Pomporo, where he was not disturbed, although he had not been officially received by the dignitaries of the village. At Dionmantene several men joined his small caravan.

After he had arrived within five miles of Niele, he was taken sick with bilious-fever, and during this time was well treated by Pegue, who daily sent him eggs, chicken, and honey.

During his rapid convalescence he tried his best to persuade Pegue to admit him to his capital, but in vain. Pegue refused, as he was influenced by his *kentelala* ("magicians"), who associated

the death of Tidiani, shortly after the departure of Lieut. Caron from Bandiagara, with the death of the chief of Furu two days after the passage of the caravan. He was therefore obliged to depart without having seen either Pegue or his capital; at least, he had received all assurances of Pegue's friendship for the French, and his promise to permit the passage of any Frenchman, provided he came alone, and not on horseback. There was no use mentioning a treaty, and the situation was not favorable.

If Samory was successful, he would reduce Nièle to ashes. Tiébe, in his turn, would do the same. An alliance between Tiébe

is divided into seven large parts and several suburbs, and contains one grand mosque and several of less importance. It is under the government of the family of Wattara. The *fama* is called Wamoko-Ule-Wattara; the chief magistrate, Diawara-Wattara; the religious chief of the population, a Musselman, is the *almamy*, Sitafa-Sakhanoko. The chief products of industry are woven goods and indigo dyes. At Marrabatou, one of the suburbs, there are more than forty dyeing-establishments.

To return to Capt. Binger, he was received with a good deal of distrust by the people, who saw in him a spy of Samory's. But as

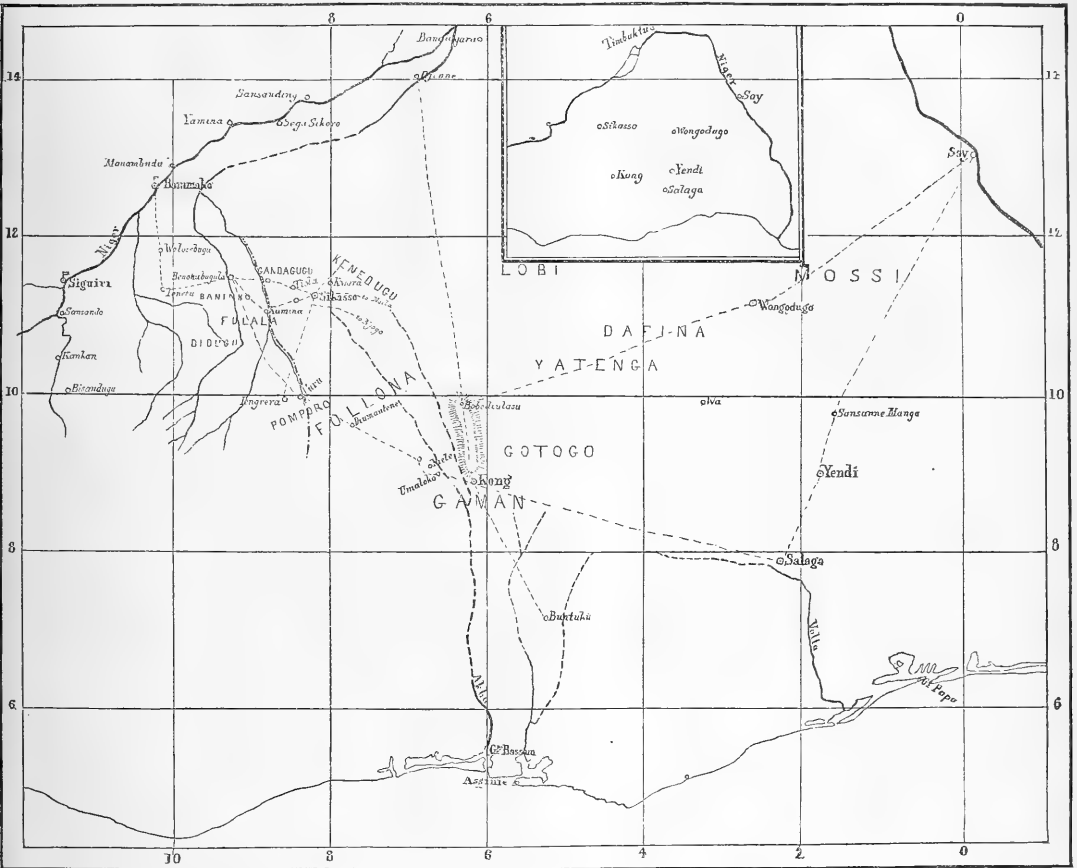

CAPT. BINGER'S JOURNEYS IN THE NIGER REGION.

and Pegue was out of the question, because the former was deterred for his cruelty, and the latter would not accept the proffered conditions. On the 3d of February, Capt. Binger left the village, and, passing Nièle, started for Umaloko, in the country of Kong. He was accompanied by one of Pegue's servants, who was to lead him safely into the first villages of the country of Kong.

On the 20th of February he arrived at Kong, having traversed two great rivers from 40 to 80 metres broad, which, coming from Sikasso, flow towards the south, and unite shortly before reaching Kong. They form, without doubt, either the Aleka (Abka or Akbo) or the Volta.

Kong, situated in west longitude $6^{\circ} 9' 43''$, and north latitude $8^{\circ} 54' 15''$, is a city of ten thousand inhabitants, and lies in a large plain at an altitude of from six hundred to seven hundred metres.

the marabouts, the leading class, decided in his favor, his safety was assured.

From the latest news, dated at Kong, March 10, and received at Bammako June 21, it was seen that Capt. Binger was to leave Kong about the middle of March, and to turn northward to Bobodulasu, where he was to arrive on the 6th or 7th of April. Thence his route lay to Wondodugu. From Wondodugu he intended to make his way to the Niger at Say, then to return to Kong by way of Sansanne-Mango, Yendi, Salaga, and Ngottogo. From Kong, finally, he wanted to reach the coast, passing through the capital of Buntuku, the position of which was not accurately determined by the English Capt. Lonsdale, who visited it in 1883.

It is now ten months since we have had news of the enterprising traveller. From the time of his departure at Bammako, up to

the time of his arrival at Kong,—a period of six months and a half,—he must have traversed from seven hundred to a thousand miles. Judging from this fact, it would take him at least a year to complete his proposed tour from the city of Kong, and his return to the same. We must not be surprised at not having heard from him: that may be due to a lack of opportunity for sending messages.

Having given this description of the journey of Capt. Binger, we can but wish that it may terminate as well as it has begun.

GUSTAVE EIFFEL.

BEFORE proceeding to speak of the Eiffel Tower in detail, *Engineering*, in its issue of May 3, in which is a noteworthy survey of the opening Paris Exhibition, takes occasion to say a few words about Gustave Eiffel and his works. Born at Dijon in 1832, he passed brilliantly through the Ecole Centrale, and commenced the active pursuit of his profession in 1855. One of his first works was the completion of the foundations of the great railway-bridge of Bordeaux by means of compressed air,—a system then but little known in France. After this work, M. Eiffel constructed a large bridge over the Nive at Bayonne, and two others at Capdenac and at Florac.

In 1867 he was intrusted by M. Krantz, the commissioner-general of the Paris Exhibition of that year, with the task of checking experimentally the calculations made for the large buildings. In 1868 he constructed, under the direction of M. de Nordling, engineer of the Orleans Company, the viaducts with iron piers, upon the line between Commentry and Gannat. It was in these viaducts that he first employed the system consistently followed by him afterwards, of wrought-iron braced structures, instead of cast-iron columns or masonry piers. A little later he introduced, with great success, a system of launching bridges from their site of erection on the ground across the piers previously built to receive them. His first attempt in this direction was in 1869, with the Sioule viaducts, followed by another at Vianna, in Portugal, where iron girders more than 1,800 feet in length were launched into position. Then came the viaduct of Tardes, near Montluçon, which was launched at a height of 328 feet above the ground, over piers 340 feet apart.

M. Eiffel was the first among French engineers to employ the system of erecting bridges of great span without scaffolding, by building out the structure piece by piece. His first work of this class was at Cubzac, near Bordeaux, where he crossed a river with a bridge 236 feet span without any staging. At Tan-an, in Cochin China, he erected in a similar way a bridge of 262 feet span. Of arched bridges built in the same manner, the most important, until it was surpassed by the viaduct of Garabit, was the great bridge over the Douro, at Oporto, the central span of which is 534 feet, and the rise of arch 138 feet, the height of rails above the water-level being no less than 200 feet. But he surpassed himself in the Garabit viaduct, where an arch 541 feet span crosses the torrent of the Truyère 400 feet above it. Among the other great engineering works carried out by M. Eiffel must be mentioned the Pesth railway-station; the Szegedin bridge; the principal façade of the Paris Exhibition of 1878; and the dome of the Observatory at Nice, 75 feet in diameter, and weighing more than 100 tons, which floats within a circular trough, so that the effort required to move it is almost inappreciable. Scarcely less remarkable as an engineering work, and as a triumph of the founder's art, is the gigantic statue of Liberty, modelled by Bartholdi, and presented by France to the United States, where it now stands lighting the entrance to the harbor of New York.

The great series of locks which were to have formed a sort of giant staircase for the passage of ships across the Isthmus of Panama was elaborated as to design, and considerably advanced as to execution, when the great work collapsed. From the foregoing rapid sketch, it will be seen that few engineering constructors have carried out so many important and original works as M. Eiffel; and the success which has uniformly attended him was a guaranty for the stability and beauty of his latest effort, the Column of the Republic, and his own monument.

Of course, the idea of a tower of gigantic height is not a new

one. Not to mention the efforts of the early engineers which had the unexpected result of inventing foreign languages, there are three better authenticated and more recent proposals than the instance in which the sons of men said, "Go to, let us build us a tower whose top may reach unto heaven, and let us make us a name." The earliest was that of the splendid but eccentric genius Trevithick in 1833; then came the proposal of the well-known American engineers, Messrs. Clarke & Reeves, who offered to construct for the Philadelphia Exhibition, in 1876, a tower, 1,000 feet in height, of wrought iron, and about 150 feet in diameter at the base. Finally, in 1881, a M. Sebillot proposed to light Paris electrically by a 1,000-foot tower.

Excepting the American project, none of these schemes had any practical value, but the proposal of Trevithick is worth referring to here. He suggested, in a letter published in the *Morning Herald* of July 11, 1832, that the passing of the Reform Bill should be commemorated by a gigantic tower made of cast iron, 1,000 feet in height, 100 feet in diameter at the base, and 12 feet in diameter at the top. It was to be set upon a stone plinth 60 feet high, and was to have a capital 50 feet in diameter, supporting a colossal statue. The shape was to be that of a cone, and an internal cylinder 10 feet in diameter was to run from the ground to the top of the structure. Trevithick proposed that the tower should be composed of 1,500 symmetrical segments, with internal flanges around their edges for bolting them together. Each segment was to be pierced with a large circular opening for lessening the weight and reducing the wind-pressure. The total weight was to be about 6,000 tons, and each of the cast-iron panels was to weigh about 3 tons. The contract price offered for the castings was £7 per ton, the total estimate of expense was under £80,000, and Trevithick undertook the erection of the column in a period not to exceed six months. Passengers were to be raised to the top of the tower in the central cylinder, which was to be fitted with a piston providing accommodation on its upper surface for twenty-five persons; and the piston was to be raised from the bottom to the top by compressed air forced into the cylinder, and controlled by suitable valves. Fortunately for the memory of Trevithick, this scheme remained upon paper.

The Eiffel Tower is the natural development of the class of work upon which its constructor has been occupied for so many years. It was the direct outcome of a series of investigations undertaken by M. Eiffel in 1885, with a view of ascertaining the extreme limits to which the metallic piers of viaducts could be pushed with safety, this special line of investigation having reference to a proposed bridge with piers 400 feet in height and 140 feet of base. The idea of the great tower followed, preliminary plans were prepared, and calculations made by two of M. Eiffel's principal engineers,—MM. Nougier and Koehlin,—and by M. Sauvestre, architect. Naturally, the leading principle followed was that adopted by M. Eiffel in all his lofty structures; namely, to give to the angles of the tower such a curve that it should be capable of resisting the transverse effects of wind-pressures, without necessitating the connection of the members forming these angles, by diagonal bracing. The Eiffel Tower, therefore, consists essentially of a pyramid composed of four great curved columns, independent of each other, and connected together only by belts of girders at the different stories, until the columns unite towards the top of the tower, where they are connected by ordinary bracing. Iron, and not steel, was used in the construction throughout.

MENTAL SCIENCE.

Psychic Cures.

OUR first record of the practitioners of the healing art describes them as invested with the priestly function, thus making the cure of physical ills a result of intellectual and religious influence. When reading the records of the past in the light of modern knowledge, we can trace almost at every point the very marked influence of mental states in the cure, sometimes described as miraculous, of disease. The repute of drugs altogether harmless, or of the physician who gave the drug, is often due to the successful action of the patient's own belief upon his susceptible system. And quite as truly are the wonderful cases of the infliction of ills by

secret curses and superstitious rites to be accounted for upon the same principle.

In more recent times the success of a host of quack remedies, supported by quasi-scientific proofs, is to be referred to the same influence of mind upon body. The existence of such influence, and its great power for good or ill, is fully admitted by modern science; its practical application has, however, been left almost exclusively to charlatans and empirics. Naturally the physician has encountered the general fact of mental influence, and more or less unconsciously profited by its benefits; but the outspoken recognition of psychic states upon physical ills has been rare, owing to the endangering of one's reputation to which such a step would lead. The result has been that a special sect, ignorant of all rational physiology, has taken up the valuable kernel of truth, and surrounded it with an enormous shell of fantastic doctrines, semi-religious and altogether unscientific, in which the original kernel is warped quite out of recognition.

In recent years the question has assumed a more scientific aspect, owing to the light shed upon it by the researches in hypnotism. In this condition, in which suggestions are obeyed with abnormal readiness, it has been shown that functions ordinarily beyond voluntary control can be influenced, and thus a way be opened up for acting upon disturbed functions and diseased conditions. With a sensitive subject, a burn can be suggested at the spot where a coin touches the skin, and the inflammation, the scar, and all, will result. Further, if the suggestion be given that of two wounds the one will heal very quickly and the other slowly, one may find the inflammation almost entirely gone from the one on the following day, while on the other it will be evident for days or even weeks. If nature's process can thus be hastened or retarded, though in a somewhat abnormal condition it is true, why should it not be possible to systematically utilize this power in the case of real ills? Isolated examples of such attempts can be pointed out. Dr. Esdaile in India performed many operations in which hypnotism was the only anæsthetic used, and Dr. Liebault of Nancy has for many years been treating his patients by hypnotic suggestion whenever it seemed desirable. The writer has recently had an opportunity to witness the well-systematized procedures of two physicians at Amsterdam — Drs. Van Renterghem and Van Eeden — in the same direction. These physicians regard hypnotism as a form of sleep very variable in intensity, and passing imperceptibly into a normal sleep. They find a very large percentage (about 75 per cent or more) partially susceptible to its influence, and make no claim beyond the power to appeal by this means to natural restorative processes where the usual means of treatment have been of little avail. The process is a gradual one, and the suggestion must be very frequently repeated before a complete cure is effected. There is no element of the mysterious about their proceedings, but simply a methodical attempt to test the powers of mental influence upon physical ills.

As just noticed, they recognize different degrees of hypnotic sleep, and regard the memory that the subject retains of what has been done during the hypnotic condition as a convenient point of distinction between them. In the lightest sleep the patient remains fully conscious of what has been going on, and can give an accurate account of it. When the sleep is deeper, his remembrance is vague, and hints must be given in order to recall the events. In the deeper sleep all recollection is gone. Of 178 persons, only 7 could not be hypnotized, and 79 were thrown into a deep sleep. The procedure is very simple, and depends entirely upon the acceptance of a suggestion. The eyelids are closed and held for a moment, the patient being told to go to sleep; or the patient fixates the physician's eye for a moment, with the same result. A breath upon the eyelids, or touch upon the nose, easily awakens the sleeper. While in this condition, the suggestions are given that the pain will be gone, that the power to move a paralyzed limb will return, that sight or hearing will improve, that hallucinations will not recur, and so on, to suit the requirements of each case. In cases of paralysis the limbs are moved for the patient, gradually extending the range of the movement, and suggesting the same motions to be effected voluntarily by the patient. In cases of partial blindness, exercises in seeing and distinguishing different objects are made under hypnotic suggestion. In brief, each case

must be treated individually; and it requires the utmost tact, aided by a pleasing and impressive manner, to accomplish the best results. To the effects of such indirect suggestions, every candid physician will testify.

As to the time of cure, this depends upon the special malady and the individual. Sometimes a single suggestion will suddenly effect an almost complete cure, while in other cases the progress is very slow. The more gradual cures are to be preferred as being more in harmony with nature's methods. The kinds of disease most readily yielding to this treatment at once suggest the processes here involved. Hysterical affections make up a considerable portion of the cases treated; and in these the combined psycho-physiological disturbance is more mental than physical. But paralysis, rheumatic troubles, palpitations of the heart, digestive irregularities, and nearly all the ills that flesh is heir to, are found upon the list of successfully treated cases. They are all, however, functional troubles. In cases of organic trouble it is evident that restoration is not more possible by this method than by another. The difficulty is, that severe functional troubles may take the appearance of being organic, especially in cases of complicated disease. It must be admitted, however, that the benefits of hypnotic treatment have a much wider extent than what are generally understood by hysterical affections. Of 162 cases treated, 91 are regarded as restored to health, 46 have improved, and only 25 have been treated without avail. The main point at issue will probably be the permanence of such cures. The question has not been studied sufficiently long to admit of a positive answer, but the proper basis for a conclusive verdict is rapidly being accumulated. As far as the evidence goes, it points to as large a percentage of permanent cures as is effected by treatment by any other method. Cases are not unknown in which, after all skill has been applied, a sudden shock or accident has effected a complete and permanent restoration. The sudden cures of hypnotism may be regarded as affiliated with this class. The far more numerous gradual cures are naturally subject to relapses, and repeated suggestion is necessary to continue the progress.

Another point that will not fail to be raised is the danger incident to such methods. The dangers are real, and of many kinds; but they are all such as, in the hands of a skillful physician, are reduced to a minimum. The avoidance of unpleasant suggestions, an easy awakening from the sleep, the suggestion that no one else but the physician can hypnotize the patient, — all contribute to a successful result.

The entire question is one that the future must decide; but it should be recognized that attempts are now in progress to clear this very fertile field of the weeds that have grown upon it, and cultivate it assiduously for the advancement of science and the benefit of mankind.

BOOK-REVIEWS.

The Primitive Family in its Origin and Development. By C. N. STARCKE. (International Scientific Series.) New York, Appleton. 12°. \$1.75.

The object of this work is to set forth the nature of the family as it exists in the most primitive form known to us, and so far as possible, to trace its origin and the course of its development. To accomplish this end, the use of the comparative method is of course essential; and hence the author takes us over the whole field of savage life, and gathers proofs and illustrations from every quarter of the globe. Mr. Starcke's views on many of the subjects treated are opposed to those hitherto prevalent, and his book is largely a polemic against the writers with whom he disagrees. Thus it has been quite commonly held that in many tribes, if not in all, the earliest state of society was one of promiscuous intercourse between the sexes, and evidence of this has been believed to exist in the widely diffused custom of reckoning descent through the mother alone. Mr. Starcke denies all this, and maintains that "the social life of man begins with the partially aquatic family, and the family group which is ruled by the father in virtue of his physical superiority. . . . Clans are subsequently formed, which, as their internal cohesion increases, gradually pass from the paternal

to the maternal line of descent" (p. 53). His account, however, of the way in which the maternal line originated is very obscure. Again, it has been a common opinion that the clan was developed out of the family, and the tribe out of the clan, so that the origin of government is to be traced back to the patriarchal rule of the father over his family. This also Mr. Starcke denies, holding that "the primitive organization of the clan is derived from that of the tribe, and not of the family. . . . The clan differed from the tribe as a part from the whole. . . . The family, on the other hand, is an altogether independent formation which flourishes within the tribe or clan. . . . The family does not develop into a clan" (pp. 276, 277). Marriage, in Mr. Starcke's view, arose, not from the sexual instinct nor from the affections, but from the desire of the man to have somebody to keep house for him. Many usages connected with the family are to be explained, in our author's opinion, by legal regulations. Thus he thinks that the names used to designate the various degrees of relationship were "the faithful reflection of the juridical relations which arose between the nearest kinsfolk of each tribe. Individuals who were, according to the legal point, on the same level with the speaker, received the same designation" (p. 207). In the same way he endeavors to account for exogamy and endogamy by legal regulations; but unfortunately he fails to tell us why the legal relations of persons came to be such as they were, rather than otherwise.

Such are Mr. Starcke's views on some of the leading topics discussed; and it is evident that they furnish material for considerable controversy. We shall not undertake any criticism of them, however, at the present time, but content ourselves with simply setting them forth. But there are certain literary faults in the book which can hardly be passed over. One of these is the obscurity with which some of the author's views are stated, which leaves the reader in doubt as to what he is trying to prove. Another fault, especially in the earlier chapters, is the excessive amount of detail, which makes us lose sight of the point under discussion in the mass of disconnected facts. In spite of these defects, however, the book will be interesting to all students of primitive society, and none the less so, perhaps, on account of its controversial character.

Hygienic Physiology, with Special Reference to the Use of Alcoholic Drinks and Narcotics. By JOEL DORMAN STEELE, Ph.D. New York and Chicago, Barnes. 12^o. \$1.

THIS is a revised edition of the well-known "Fourteen Weeks in Human Physiology," and therefore needs no special comment. The subject of disinfectants occupies but a single page, and is unfortunately not in accord with the best knowledge that we possess on this important subject. The published reports of the American Public Health Association furnish more reliable information as to methods of disinfection, and we are surprised that in the preparation of this volume they were not consulted, rather than adopting the recommendations of the National Board of Health, which were reliable ten years ago, but are, so far as we know, not followed by any sanitary authorities at the present day.

A Hand-Book of Cryptogamic Botany. By ALFRED W. BENNETT and GEORGE MURRAY. London and New York, Longmans, Green, & Co. 12^o. \$5.

THAT a text-book on this subject is greatly needed will be readily understood when the statement is made that no general hand-book on cryptogamic botany has appeared in the English language since that of Berkeley in 1857. As the authors of the present volume truly say, since then this department of botanical science has gone through little less than a revolution. Not only has the number of known forms increased enormously, but additions of great importance have been made to our knowledge of structure by the use of the microscope, and to the genetic connection of different forms by the careful following-out of the life-history of particular species. The main object of the present work is to bring within the reach of botanists, and of the public generally who are interested in the study of nature, an acquaintance with the present state of knowledge in this branch of science. The authors recognize that the question of terminology is one of the greatest stum-

bling-blocks to the student of cryptogamy; and they have, commendably we think, simplified the scientific terms whenever possible. Thus they employ throughout the volume "sporangium," "archegonium," "antheridium," "cœnocyte," "sclerote," "epiderm," etc., in place of the Latin and Greek forms hitherto used. The arrangement of the subject-matter is admirable, and the illustrations are sufficiently abundant and well executed for the purpose for which they were designed. Of the type and paper, and the general execution of the work, too much cannot be said in the way of praise.

Outlines of Lessons in Botany, for the Use of Teachers, or Mothers studying with their Children. By JANE H. NEWELL. Boston, Ginn. 16^o.

THESE lessons are suitable for children of twelve years and upward, and are arranged after the plan of Gray's "First Lessons" and "How Plants Grow," and are intended to be used in connection with either of those books. The author's aim has been to prepare such outlines as will aid teachers in fostering in their pupils the power of observation and clear expression. The volume deals with plants and their uses as food, clothing, fuel, and in the purification of the air. Directions are given for the raising of the morning-glory, sunflower, bean, and pea in the schoolroom or at home, and what to observe in the roots, stem, buds, branches, and leaves of these and other plants. Twenty-five well-drawn figures aid the text very materially.

AMONG THE PUBLISHERS.

TICKNOR & Co. have in preparation Pfeiffer's "American Mansions," a series of designs by Mr. Carl Pfeiffer for dwelling-houses of various classes, with all their details, both decorative and constructive, carefully worked out.

— Charles Scribner's Sons will publish shortly the second volume of Professor Charles W. Shields' "Philosophia Ultima;" and "Progress of Religious Freedom as shown in the History of the Toleration Acts," by the Rev. Dr. Philip Schaff.

— Roberts Brothers published on the 14th the second division of Rénan's "History of the People of Israel," from the reign of David up to the capture of Samaria.

— D. Appleton & Co. have ready "The Primitive Family in its Origin and Development," by Professor C. N. Starcke of the Copenhagen University, which forms Vol. LXV. of the International Scientific Series; Part V. of Vol. III. of Roscoe and Schorlemmer's "Treatise on Chemistry," covering "The Chemistry of Hydrocarbons and their Derivatives;" and "How to Study Geography," by Francis W. Parker, which forms Vol. X. of the International Education Series. They have in preparation "An Epitome of Herbert Spencer's Synthetic Philosophy;" "Stellar Evolution," by Dr. James Croll; "European Schools in 1888," by Dr. L. R. Klemm; "A Dictionary of Terms in Art;" and the annual volume for 1888 of "Appletons' Annual Cyclopædia."

— The J. B. Lippincott Company will publish next week, by subscription, the first volume of "The Cyclopædia of the Diseases of Children," by American, British, and Canadian authors, edited by John M. Keating, M.D.

— Professor John F. Genung of Amherst College has published through Messrs. Ginn & Co. of Boston a "Handbook of Rhetorical Analysis," intended to be a companion to his treatise on rhetoric. It consists of extracts from some twenty English writers, mostly of the present century, with notes and questions designed to lead the student to a proper appreciation of the qualities of style and thought which they exhibit. Most of the extracts are excellent, some of them being chosen for their style, and others for the depth of thought or power of invention shown in them. The editor's notes and questions are very numerous, and sometimes very suggestive, and we should think the volume would be quite useful to students of style and composition.

— As evidence of the wide interest that has been taken during the past year in the contents of *The Forum*, is cited the fact that in that period more than three thousand editorial articles suggested by *Forum* articles were printed in American and English papers.

—Gebbie & Co., Philadelphia, will shortly publish "Half a Century of Music in England," by the late Francis Hueffer. The book was finished just before the death of the popular author.

—D. C. Heath & Co. will soon publish the "Public School Music Course," by Charles E. Whiting, formerly teacher of music in the Boston public schools. It will be a series of six graded music-readers, adapted to all the primary and grammar-school

grades, and intended to lead up to the author's "High School Music Reader." Time-names, breathing-marks, etc., are included, and every thing necessary for a complete music course. There is a large number of one, two, three, and four part songs, selected from the best German, English, French, and American composers. Each of the first three numbers has, besides the songs, over three hundred exercises. The first two books will be illustrated.

Publications received at Editor's Office,
May 6-11.

- AMERICAN Water-Works, The Manual of, 1888. New York, Engineering News 611 p. 8¢.
- CASEY, J. A Treatise on Spherical Trigonometry, and its Application to Geodesy and Astronomy. London and New York, Longmans, Green, & Co. 160 p. 12¢. \$1.50.
- CONNECTICUT Agricultural Experiment Station, Annual Report of, for 1889. Part I. New Haven, State, 48 p. 8¢.
- CONNECTICUT State Board of Health, Eleventh Annual Report of the, for the Year ending Nov. 30, 1888; with the Registration Report for 1887, relating to Births, Marriages, Deaths and Divorces. New Haven, State, 509 p. 8¢.
- GENUNG, J. F. Handbook of Rhetorical Analysis. Boston, Ginn, 306 p. 12¢. \$1.25.
- GOULD, J. The Birds of Great Britain. Part XIV. London and Manchester, H. Sotheran & Co. Colored plates. 19. 63 75.
- A Monograph of the Trochilidae or Humming Birds. Part XXI. London and Manchester, H. Sotheran & Co. Colored plates. 19. 63 75.
- The Birds of New Guinea and the Adjacent Papuan Islands, including any New Species that may be discovered in Australia. Part XXII. London and Manchester, H. Sotheran & Co. Colored plates. 19. 63 75.
- HOG Cholera: its History, Nature, and Treatment, as determined by the Inquiries and Investigations of the Bureau of Animal Industry. Washington, Government, 103 p. 8¢.
- KLEIN, E. The Bacteria in Asiatic Cholera. London and New York, Macmillan, 170 p. 16¢. \$1.25.
- METEOROLOGICAL Bibliography of. Part I. Temperature. Ed. by Oliver L. Fassig. Washington, Signal Office, 381 p. 8¢.
- MINNESOTA, The Geological and Natural History Survey of. Sixteenth Annual Report for the Year 1887. St. Paul, State, 504 p. 8¢.
- NEW YORK Meteorological Observatory of the Department of Public Parks, Central Park, New York City, Report of, for the Year 1889. New York, Daniel Draper, Ph. D., 8¢.
- PIERSON, E. DeL. The Black Ball. Chicago, New York, and San Francisco, Belford, Clarke, & Co. 223 p. 12¢. 50 cents.
- ROOSVELT, C. The Art of Protecting Domestic Industries; The Science of Government, founded on Natural Law; Paradox of Political Economy. New York, The Author, 123 p. 8¢.
- STARBUCK, C. N. The Primitive Family in its Origin and Development. (Internat. Scient. Ser.) New York, Appleton, 315 p. 15¢. \$1.75.
- TAYLOR, J. E. The Playtime Naturalist. New York, Appleton, 257 p. 12¢. \$1.50.

Correspondence solicited with parties seeking publishers for scientific books.

N. D. C. HODGES,
Publisher of Science,
47 Lafayette Place,
New York.

Old and Rare Books.

One Million Magazines. Back numbers, vols. and sets—old and new, Foreign and American. CATALOGUE UPON APPLICATION.
A. S. CLARK,
34 Park Row, New York City.

BACK NUMBERS and complete sets of leading Magazines. Rates low. AM. MAG. EXCHANGE, Schoharie, N.Y.

H. WILLIAMS,
Dealer in Old Magazines, Reviews, &c. Scientific periodicals a specialty. 39 Macdougall St., N.Y.

Just Published.

1 Vol., 400 Pages, 30 Full-page Plates, and 75 Illustrations in Text. Price \$6.00.

Sewerage and Land Drainage,

BY
GEORGE E. WARING, JR.,

Honorary Member of the Royal Institute of Engineers (Holland); Member of the Institution of Civil Engineers (England); Fellow of the Sanitary Institute of Great Britain; Corresponding Member of the American Institute of Architects;

CONSULTING ENGINEER
For Works of Sanitary and Agricultural Drainage.

D. VAN NOSTRAND COMPANY,
PUBLISHERS,
23 Murray and 27 Warren Streets, New York.



GAUSS AND WEBER, who proposed and employed the system of absolute measurements, early in the present century.

**The Electrical Articles
IN SCRIBNER'S MAGAZINE**



are begun in The June Number, by Prof. C. F. Brackett of Princeton, by a paper entitled "Electricity in the Service of Man," setting forth in a clear, precise way, some of the common methods by which the more important electrical phenomena are produced. The illustrations are copious and beautiful. Other articles in the series will follow (*i.e.*), "Electricity in Modern Telegraphy," by Charles L. Buckingham, chief electrical expert of Western Union Tel. Co.; "Electricity in Lighting," by Henry Morton, President Stevens' Institute; "Electricity in the Household," by A. E. Kennelly, chief electrician in laboratory of Thomas A. Edison; "Electricity in relation to the Human Body," by Dr. M. Allen Starr; "Electricity in Warfare," by Lieut. W. S. Hughes, U.S.N.; "Electricity in Large Industries," etc., etc., etc.

This will be one of the most interesting and valuable series of articles ever attempted. Nothing will be left undone to make it surpass in popularity the "Rail-road Series," begun about a year ago in Scribner's.

Among other valuable Articles in The June Scribner are one on "Building Loan Associations," and another on "Striped Bass Fishing."

Price 25 cents a number, \$3 00 a year. Begin your subscription with June No., which contains the first of the electrical articles.

CHARLES SCRIBNER'S SONS, Publishers.

743-745 BROADWAY, NEW YORK.

— The question of what to cook for young children, and how to cook it, is given considerable prominence in the May number of *Babyhood*, which contains an article on the subject, the first of a series. The number contains also an article on constipation, by Dr. John Dorning, which is designed to answer the surprisingly large number of questions concerning this widespread trouble of infancy that are constantly being addressed to the medical editor of *Babyhood*. A new feature of decided educational value is the introduction of a department of "Botany for the Little Ones," showing how the study of plant-life may be rendered fascinating to the youngest children. The mothers themselves contribute to the "Parliament" an unusually large number of interesting letters on such topics as "Dress Reform and Physical Improvement," "Kill or Cure Methods," "Ways and Means at the Table," "An Effectual Method of Subduing Restlessness," "Pastimes in Travelling with Children," etc.

— "People I've Smiled With, or, Recollections of a Merry Little Life," is the happy title of Marshall P. Wilder's forthcoming book which Messrs. Cassell & Co. will publish within a few weeks. Everybody knows Marshall Wilder, and everybody likes him and admires the plucky fight he has made against physical odds. He gets an unusual amount of pleasure out of life, and gives a great deal to other people too. He has a sunny disposition, and he knows how to make people laugh. The consequence is, that he is in constant demand for public halls and private houses; and he has not only made a lot of money, but he has made hosts of friends. In this country he counts among the late Gen. Grant, Ex-President Cleveland, the late H. W. Beecher, Gen. Sherman, James G. Blaine, Gen. Horace Porter, Chauncey M. Depew, and scores of others. In England he hobnobbed with the "swells" from the Prince of Wales down the list. All of these he serves up in his kindly way as "People I've Smiled With."

— Early in June, Longmans, Green, & Co. will issue in New York the first number of *The New Review*, an English monthly started by Mr. Archibald Grove, a young Oxford man. In the strength of its articles and in the reputation of its contributors, it is to rival the *Nineteenth Century*, while its low price will put it within reach of a far wider public. Three Americans—Lady Randolph Churchill, Mr. Henry George, and Mr. Henry James—are among the contributors to the first number.

— The *Nineteenth Century* for May (New York, Leonard Scott Publication Company, 29 Park Row) more than retains the high place this review has made for itself. The reader will doubtless turn first to Dr. Wace's reply to Professor Huxley's rejoinder on agnosticism in the April number, in which he emphasizes the position he took in his previous paper, and takes Professor Huxley to task for some of his misstatements. The Bishop of Peterborough also has a brief word to say on the same subject. Lord Armstrong reviews the "New Naval Programme," recently adopted in England, which he considers of a more systematic and business-like character than any similar document previously emanating from the admiralty. Professor Edward Dicey has a paper on the "Lesson of Birmingham," in which he reviews the meaning of the late election in that city. The Countess of Jersey has a pleasant paper on the "Hindu at Home," describing the daily life of the Hindus. Miss Clementina Black summarizes a remarkable speech by a working-woman at the formation of a trades-union in Liverpool. Professor H. Geffcken, who achieved notoriety in connection with the publication of the Emperor Frederick's diary, and who has the subject of special persecution by Prince Bismarck, contributes a paper on "Church and State in Germany," in which he makes an eloquent plea for the restoration of the independence of the Evangelical Church. An especially timely paper is a story of a visit by Edward Clifford to Father Damien and the lepers, whose recent death has concentrated public attention upon his heroic work in the Sandwich Islands. Frederick Marshall writes on "Society and Democracy in France," depicting some of the later changes in French social growth. Frederick Greenwood discusses "Misery in Great Cities," comparing the relative advantages of city and country life, and suggesting remedies for the alleviation of the condition of the working-people. Frederic Harrison reviews the results of the Parnell trial as affecting the cause of home rule, which is, he

says, "by far the largest, most momentous, and most complex question which has ever divided England since the Revolution." The number concludes with a paper by Mr. Gladstone, entitled "Italy in 1888-89," in which he records the observations made in his recent visit to that country. Mr. Gladstone had not visited Naples for twenty-nine years, and is therefore able to note astonishing changes. He reviews the results of the Italian revolution, and considers the present condition of the country both internally and as a European power.

— When Mr. Bright had to make a great speech, says the *Contemporary Review*, he brooded over it day after day, but he did not care to don all his preparation at his desk or in solitude. As arguments and illustrations occurred to him, he liked to try their effect by talking them over with his friends; and when he was at home, if nobody else was within reach, he talked them over with his gardener. The speech took shape in conversation. Then he made the notes which he intended to use when the speech was delivered. He gave an account of these notes in a letter, in which he said, "As to modes of preparation for speech-making, it seems to me that every man would readily discover what suits him best. To write speeches, and then to commit them to memory is, as you term it, a double slavery, which I could not bear. To speak without preparation, especially on great and solemn topics, is rashness, and cannot be recommended. When I intend to speak on any thing that seems to me important, I consider what it is that I wish to impress upon my audience. I do not write my facts or my arguments, but make notes on two or three or four slips of paper, giving the line of argument, and the facts, as they occur to my mind, and I leave the words to come at call while I am speaking. There are occasionally short passages which, for accuracy, I may write down, as sometimes also, almost invariably, the concluding words or sentences may be written. This is very nearly all I can say on this question. The advantage of this plan is, that, while it leaves a certain and sufficient freedom to the speaker, it keeps him within the main lines of the original plan upon which the speech was framed; and what he says, therefore, is more likely to be compact, and not wandering and diffuse." It was his habit, when he spoke on the platform, to place his notes on the brim of his hat, which stood on the table before him. They were written on half-sheets of note-paper. Extracts of more than three or four lines in length which he intended to quote in support of his statements were usually written on similar half-sheets, separately numbered, and were carefully placed on the table by the side of the hat. His annual speeches to his constituents rarely extended over less than an hour; and they as rarely exceeded an hour and five minutes. But the sheets of notes varied greatly in number: sometimes he had only four or five, sometimes he had eight or nine, and I think that occasionally he had still more.

— Lee & Shepard have just ready "Incidents of a Collector's Rambles," by Sherman F. Denton of the Smithsonian Institution, — a volume of travel by a keen observer of nature, and a graphic story-teller, illustrated with views and pictures of strange people and things seen in the far-off countries which he has visited; "Burgoyne's Invasion of 1777," with an outline sketch of the American invasion of Canada, 1775-76, by Samuel Adams Drake, with maps, portrait, and illustrations,—the first of a contemplated series of decisive events in American history, designed as a textbook for supplementary reading in schools and for general reading; "Every-Day Business," notes on its practical details, arranged for young people by M. S. Emery; and "Observation Lessons," — a manual for teachers, presenting practical methods of teaching elementary science to the young, — by Louisa P. Hopkins, of Boston public schools.

— Little, Brown, & Co. have just ready the American edition of "A Complete Concordance to the Poems and Songs of Robert Burns," compiled and edited by J. B. Reid.

— *Harper's Weekly* of last week contains an eight-page supplement with an article on "Prehistoric Arizona," by Col. R. J. Hinton, illustrated by Harry Fenn.

— D. Appleton & Co will publish early in the summer, "Days Out of Doors," by Dr. Charles C. Abbott, whose "Naturalist's Rambles about Home" is so well known.

GUARANTY INVESTMENT COMPANY

CAPITAL \$250,000.

Offices: Atchison, Kan. 191 Broadway, New York. 222 Walnut St., Phila.

Hon. ALBERT H. HORTON (Chief Justice, Kansas Supreme Court), Topeka, Kan., Pres't.

7% Guaranteed Farm Mortgages 7%

The Guaranty Investment Company makes loans upon fertile farms in the choicest portions of Kansas and Nebraska and has adopted the policy of sending a Committee of its Investors each year to examine its loans and methods of business.

The Committee this year consisted of PROF. A. H. BERLIN, Principal of the High School Montrose, Pa., and MAJ. THEODORE L. POOLE, Ex-U. S. Pension Agent, Syracuse, N. Y. Both of these gentlemen are persons of the highest character and have the confidence of the Communities in which they reside.

The Committee has recently returned and has made a very interesting Report upon the general development of Kansas and Nebraska as well as the business of the Company. The Company will be glad to send this Report to any address.

The following names are taken from the long list of Investors in our Mortgages:

(See if Some Friend of Yours is not in the List.)

William A. Cauldwell, 59 Liberty St., N.Y.
Palmer Cox, 68 Broadway, N.Y.
Rev. Jos. H. Rylance, D.D., 11 Livingston Place, N.Y.
Rev. Brady R. Backus, D.D., 360 West 28th St., N.Y.
Rev. R. M. Sommerville, 126 West 43th St., N.Y.
Dr. Robert A. Murray, 125 West 23d St., N.Y.
Dr. James P. Tuttle, 136 West 41st St., N.Y.
H. Edwards Rowland, 218 Fulton St., N.Y.
Irving H. Tift, Esq., 271 Broadway, N.Y.
Prof. D. G. Eaton, 55 Pineapple St., Brooklyn, N.Y.
Dr. F. E. Thwing, 156 St. Marks Ave., Brooklyn, N.Y.
Dr. C. C. Miles, Greenport, N.Y.
John V. N. Bergen, Fort Jefferson, N.Y.
Benj. W. Stillwell, Yonkers N.Y.

R. C. Coleman, Goshen, N.Y.
Mrs. Samuel Carlisle, Newburg, N.Y.
Dr. C. C. Bartholomew, Ogdensburg, N.Y.
Rev. Nelson Millard, D.D., Rochester, N.Y.
Rev. Horace G. Hinsdale, D.D., Princeton, N.J.
Dr. Charles M. Howe, Passaic, N.J.
George A. Skinner, 5 Railroad Place, Newark, N.J.
Dr. Edwin M. Howe, 85 Halsey St., Newark, N.J.
Dr. H. G. Buckingham, Clayton, N.J.
Dr. Martin Cole, Jr., Hainesville, N.J.
Mortgage Trust Co. of Pa., Philadelphia, Pa.
Miss Mary Miller, 230 Spruce St., Philadelphia, Pa.
Henry D. Biddle, 311½ Walnut St., Philadelphia, Pa.

Dr. Calvin C. Halsey, Montrose, Pa.
Rev. William Baldwin, Great Bend, Pa.
Gen. William Lilly, Mauch Chunk, Pa.
Second Nat. Bank, Mauch Chunk, Pa.
Enos E. Thatcher, West Chester, Pa.
Mrs. Townsend Poore, Scranton, Pa.
Rev. Burdett Hart, D.D., New Haven, Conn.
Dr. Frank H. Wheeler, New Haven, Conn.
Charles R. Christy, Stamford, Conn.
Mrs. Catharine P. Fuller, Woodmont, Conn.
Miss Jessie Henderson, Lenox, Mass.
Dr. M. J. Halloran, Worcester, Mass.
Albert Walker, Bennington, Vt.

Address for Report and Monthly Bulletin

HENRY A. RILEY, General Eastern Manager, 191 Broadway, N.Y.

A NEW MAGAZINE—THE SWISS CROSS
Devoted to spreading a love of nature among the people. Edited by HARLAN H. BALLARD, President of the Agassiz Association, and succeeding *St. Nichol* & as the official magazine of that body. \$1.50 a year. Sample copy fifteen cents for trial subscription for 3 months.
N. D. C. HODGES, PUBLISHER.
Mention this magazine 4 Lafayette Place, New York.

Original, Simple, Natural, Suggestive, Comprehensive, Educational and helpful entirely apart from the memory phase of the subject. JOURNAL OF EDUCATION

Memory SHEDD'S NATURAL METHOD, PRACTICAL, SCIENTIFIC.

Entirely different from any other memory method. Thoroughly taught by correspondence. ENDORSED BY LEADING EDUCATORS. DESCRIPTIVE PAMPHLET FREE. MEMORY SCHOOL, 4 W. 14th STREET NEW YORK CITY.

IMPROVING THE MEMORY PICK

and facilitating the acquirement of knowledge by lectures and correspondence. Classes forming. "MEMORY and its Doctors," from Simonides to "Loisette," mailed for 10 cents. DR. PICK, 24 Union Square, N. Y. City.

Schools.

CONNECTICUT, NEW HAVEN, MRS. CADY'S SCHOOL FOR YOUNG LADIES. Prepares for Smith and Wellesley, and admits to Vassar by Certificate. Circulars. Early application necessary.

INDIANA, TERRE HAUTE, ROSE POLYTECHNIC INSTITUTE.—A School of Engineering. Well equipped, well equipped departments of Mechanical and Civil Engineering. Electricity, Chemistry, Drawing. Extensive Shops & Laboratories. Expenses low. For catalogue address T. C. Mendenhall, Pres.

NEW JERSEY, PLAINFIELD, THE CHESTNUTS.—Parents with daughters to educate, or orphan girls with companion, may find a comfortable home, with school instruction by applying to Miss E. E. Kenyon.

SUMMER DRESSES.

We call attention to the following specialties for this week:
Black and White Striped Armure Royale, at 80 cents; regular price, \$1.15.
Black Satin Princess, \$1; regularly, \$1.25.
1,000 yards Pekin Printed Foulé at 75 cents per yard, case price, \$1.25.
1,500 yards Figured Bengaline, at 75 cents, former price, \$1.25.
1,750 yards Silk Warp Henrietta, at 75 cents, usual price \$1.
These fabrics are all peculiarly adapted for use at this season of the year.

JAMES McCREERY & CO.
BROADWAY AND ELEVENTH STREET, NEW YORK.



KIMBALL'S STRAIGHT CUT CIGARETTES

Unsurpassed in quality. Used by people of refined taste. Highest award at Brussels, 1888. The finest smoking mixtures are of our manufacture. Fifteen First Prize Medals. WM. S. KIMBALL & CO., Rochester, N.Y.

Readers of Science Corresponding with or visiting Advertisers, will confer a great favor by mentioning this paper.

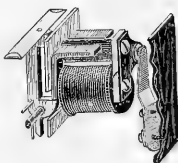

A DROP IN THE PRICE OF GRAVITY

GRAVITY DROP ANNUNCIATORS.

DON'T FORGET THE

DUST-PROOF BELLS.

HAZAZER & STANLEY,

32 Frankfort Street, N. Y.

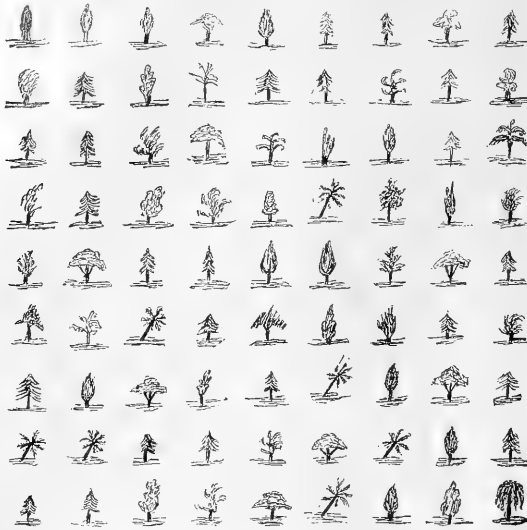

Can any reader of Science solve the following puzzle?

A man having 81 trees to cut, arranged as above, cuts nine each day for nine days without cutting on any one day more than one tree from any line, vertical, horizontal, or diagonal.

Any one who will have the following blank filled out by a responsible Newsdealer, and mailed to us, will be allowed a three months' subscription to *Science*.

N. D. C. HODGES,
47 LAFAYETTE PLACE, NEW YORK.

1889.

To the News Company.

You may add to my regular order five copies of SCIENCE each week (returnable).

SCIENCE CLUBBING RATES.

10% DISCOUNT.

We will allow the above discount to any subscriber to *Science* or *The Swiss Cross* who will send us an order for periodicals exceeding \$10, counting each at its full price.

	Per Subscription.	With Science.	With The Swiss Cross.
Agricultural Science.....	\$ 2.50	\$ 5.30	\$ 4.50
American Agriculturist.....	1.50	4.30	2.50
American Analyst.....	1.00	4.25	2.25
American Architect and Building News.....			
Imperial edition.....	10.00	12.80	11.00
Gelatine.....	7.00	9.80	8.00
Regular.....	6.00	8.80	7.00
American Gardener.....	1.00	4.25	2.25
American Journal of Philology.....	3.00	5.25	4.25
American Machinist.....	2.50	5.30	4.50
American Naturalist.....	4.00	7.50	5.50
Andover Review.....	4.00	6.80	5.00
Atlantic.....	4.00	6.80	5.00
Babyhood.....	1.50	4.30	2.50
Bible.....	1.50	3.75	1.75
Bradstreet's.....	5.00	7.80	6.00
Brain.....	3.50	6.30	4.50
Building (weekly).....	6.00	8.80	7.00
Carpentry and Building.....	1.00	4.25	2.25
Century Magazine.....	4.00	6.80	5.00
Chautauquan, The.....	1.50	4.30	2.50
Christian Union, The.....	3.00	5.80	4.00
Christian Worker, Illustrated.....	2.50	5.30	3.50
Cosmopolitan, The.....	3.00	4.80	3.00
Critic.....	3.00	5.80	4.00
Eclectic Magazine.....	5.00	7.80	6.00
Edinburgh Review.....	4.00	6.80	5.00
Electrical World.....	4.00	6.80	5.00
Electrician and Electrical Engineer.....	3.00	5.80	4.00
Electrical Review.....	3.00	5.80	4.00
Engineering and Mining Journal.....	4.00	6.80	5.00
English Illustrated Magazine.....	4.00	6.80	5.00
Forest and Stream.....	4.00	6.80	5.00
Forum, The.....	5.00	7.80	6.00
Godey's Lady's Book.....	2.00	4.80	3.00
Harper's Bachelor.....	4.00	6.80	5.00
Harper's Magazine.....	4.00	6.80	5.00
Harper's Weekly.....	4.00	6.80	5.00
Harper's Young People.....	2.00	4.80	3.00
Herald of Health.....	1.00	2.25	2.25
Illustrated London News (Amer. reprint).....	4.00	6.80	5.00
Independent, The.....	5.00	7.80	6.00
Inter Ocean, The.....	1.00	4.25	2.25
Iron Age (weekly).....	4.50	7.30	5.50
Journal of Philology (Eng.).....	2.50	5.30	3.50
Journal of Speculative Philosophy (begins with Jan. No.).....	3.00	5.80	4.00
Judge.....	4.00	6.80	5.00
L'Art.....	12.00	14.80	13.00
Life.....	5.00	7.80	6.00
Lippincott's Magazine.....	3.00	5.80	4.00
Littell's Living Age.....	8.00	10.80	9.00
Little Men and Women.....	1.00	4.25	2.25
London Quarterly.....	4.00	6.80	5.00
Macmillan's Magazine.....	5.00	7.80	6.00
Magazine of American History.....	5.00	7.80	6.00
Medical and Surgical Journal.....	5.00	7.80	6.00
Mechanical Engineer.....	2.00	4.80	3.00
Metal Worker.....	1.00	4.25	2.25
Microscope, The.....	1.00	4.25	2.25
Nature.....	6.00	8.80	7.00
New Princeton Review.....	3.00	5.80	4.00
North American Review.....	5.00	7.80	6.00
Outing.....	3.00	5.80	4.00
Overland Monthly.....	4.00	6.80	5.00
Pansy.....	1.00	4.25	2.25
Political Science Quarterly.....	3.00	5.80	4.00
Popular Science Monthly.....	5.00	7.80	6.00
Popular Science News.....	1.00	4.25	2.25
Portfolio, The.....	7.50	10.30	8.50
Practioner.....	3.00	5.80	4.00
Public Opinion.....	3.00	5.80	4.00
Puck.....	5.00	7.80	6.00
Puck (German).....	5.00	7.80	6.00
Scientific American.....	3.00	5.80	4.00
Supplement.....	5.00	7.80	6.00
Architect and Builders' edition.....	2.50	5.30	3.50
Scientific Monthly.....	3.00	5.80	4.00
Southern Cultivator.....	1.50	4.30	2.50
Springfield Republican (weekly).....	1.00	4.25	2.25
Sunday School Times.....	2.00	4.80	3.00
Teachers' Institute.....	1.25	4.25	2.25
Texas Siftings.....	1.00	4.80	3.00
Trained Nurse.....	1.50	4.30	2.50
Treasure-Trove.....	1.00	4.25	2.25
Truth-Seeker, The.....	3.00	5.80	4.00
Wide Awake.....	1.40	4.20	2.40
Young Folks' Journal.....	1.00	4.25	2.25



BRANCH AT 728 CHESTNUT ST.
PHILADELPHIA, PA.

JOHN HASTINGS = A=R=HART = JOS=TRIPP =
Prest. Genl. Mgrs. V. Prest.

ENGRAVING FOR
ARTS ILLUSTRATIVE
AND ADVERTISING
PURPOSES

67-71 PARK PLACE
NEW YORK

N. D. C. HODGES,
47 Lafayette Place,
New York.

C. & C. ELECTRIC MOTOR COMPANY.

Electric Motors
FOR
Arc and Incandescent Circuits, Most Economical Motor on the Market.
Regulation Perfect.
Motors Designed for all Power Purposes.

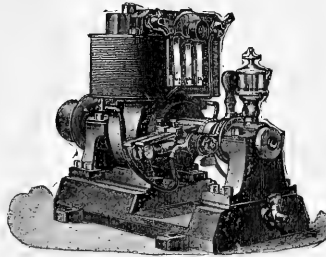

OFFICE and MANUFACTORY:
402 and 404 Greenwich Street, New York City.
New England Office, 19 Pearl St., Boston.
Philadelphia Office, 301 Arch St.
Western Office, 139-141 Adams Street, Chicago.
Southern Office, 25 Carondelet Street, New Orleans.

"The Week, one of the ablest papers on the continent."—*Descriptive America.*

ENLARGED AND IMPROVED.
THE WEEK:
A Canadian Journal of Politics, Literature, Science and Arts.
PUBLISHED EVERY FRIDAY.
\$3.00 per Year. \$1.00 for Four Months.

THE WEEK has entered on its SIXTH year of publication, greatly enlarged and improved in every respect, rendering it still more worthy the cordial support of every one interested in the maintenance of a first-class literary journal.

The independence in politics and criticism which has characterized THE WEEK ever since its first issue will be rigidly maintained; and unceasing efforts will be made to improve its literary character and increase its value and attractiveness as a journal for the cultured home. Many new and able writers are now, or have promised to become, contributors to its columns, and the constant aim of the Publisher will be to make THE WEEK fully equal to the best literary journals in Britain and the United States.

As heretofore, PROF. GOLDWIN SMITH will, from time to time, contribute articles. London, Paris, Washington and Montreal letters from accomplished correspondents will appear at regular intervals. Special Ottawa Letters will appear during the sessions of Parliament.

THE WEEK in its enlarged form will be the same size as "Harpers Weekly," and the largest paper of its class on the continent.

SEND FOR FREE SAMPLE COPY.

C. BLACKETT ROBINSON, Publisher,
5 Jordan St., Toronto.

A NEW MAGAZINE—THE SWISS
Devoted to spreading the knowledge of the people. Edited by HARLAN H. BALLARD, President of the Agassiz Association, and succeeding St. Nicholas as the official magazine of that body. \$1.50 a year. Sample copy 10 cents, or 25 cents for trial subscription for 3 months.
N. D. C. HODGES, PRINTER,
Mention this paper. 47 Lafayette Place, New York.

Wants.

A YOUNG MAN can have lucrative engagement, not only a fixed salary, but according to his work accomplished in travelling for SCIENCE. A personal interview invited.
N. D. C. HODGES,
47 Lafayette Place, New York.

MECHANICIAN.—An optician and maker of instruments of precision of experience would be glad of a position where his skill would be valued in connection with some higher educational institution. Address G. J., care of SCIENCE, 47 Lafayette Place, New York.

Scientific Apparatus.

J. GRUNOW,
621 Sixth Avenue, New York.
Established 1852.

MAKER OF

Microscope Stands, Oil Immersion Objectives and Abbe Condensers for Bacterial and Histological work, of Objectives, Camera Lucida and other accessory apparatus.

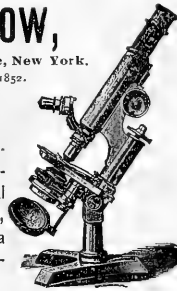

IMPROVED OIL LIGHT
MAGIC LANTERNS.

Also Lime and Electric Light Apparatus, and mechanical, plain, and fine colored views.

J. B. COLT & CO., Manufacturers,
No. 16 BEEKMAN STREET, NEW YORK.

MAGIC LANTERNS Stereopticons and the Best Views for Public, Church, Home, and Scientific Exhibitions. Best apparatus, new views. Largest stock. Reduced prices. 24 Years' Practical Experience. Illus. Catalogue Free.

GEO. H. PIERCE,
136 S. Eleventh St., Philadelphia, Pa.

ELECTRICAL TESTING BUREAU,

Johns Hopkins University, Baltimore, Md.
Resistance Coils and Boxes Compared.
Am meters and Volt meters calibrated.
Condensers standardized.
Primary and Secondary Batteries Tested.
Efficiency of Dynamometers Determined.
Insulation of Cables and Wires Tested.
Etc., Etc.
Circulars describing Methods Used, Prices, Etc., sent on Application.
Address as above.

MORRIS EARLE & CO.
SUCCESSORS TO
R. & J. BECK,

1016 Chestnut Street Phila
Microscopes and all Accessories and Apparatus. Photographic and Photo-Micrographic Apparatus and Outfits.

Spectacles, Eye Glasses, Opera and Marine Glasses, etc.
Illustrated Price List mailed free to any address. Mention SCIENCE in corresponding with us.



Amateur Outfits in great variety, from \$5.00 upward. Send for Catalogue or call and examine. More than 40 years established in this line of business.

E. & H. T. ANTHONY & CO.,
551 Broadway, N.Y.

Manufacturers and Importers of PHOTOGRAPHIC INSTRUMENTS, Apparatus and Supplies of every description. Sole proprietors of the Patent Detective, Fairy Novel, and Bicycle Cameras, and the Celebrated Stanley Dry Plates.



GOOD NEWS TO LADIES.

Greatest inducements ever offered. Now's your time to get orders for our celebrated Teas and Coffees, and secure a beautiful Gold Band or Moss Rose China Tea Set, Dinner Set, Gilt Band Moss Rose Toilet Set, Watch, Brass Lamp, or Webster's Dictionary. For full particulars address THE GREAT AMERICAN TEA CO., P. O. Box 289. 81 and 83 Vesey St., New York

A TEMPORARY BINDER

for Science is now ready, and will be mailed postpaid on receipt of price.



Half Morocco - 75 cents.
This binder is strong, durable and elegant, has gilt side-title, and allows the opening of the pages perfectly flat. Any number can be taken out or replaced without disturbing the others, and the papers are not mutilated for subsequent permanent binding. Filed in this binder, Science is always convenient for reference.

N. D. C. HODGES,
47 Lafayette Place, N. Y.

Readers of Science

Corresponding with or visiting Advertisers will confer a great favor by mentioning the paper.

Sprague Electric Railway and Motor Company.

For Stationary or Railway Work,
for Mining or Engineering
operations the SPRAGUE MOTORS
are unexcelled.

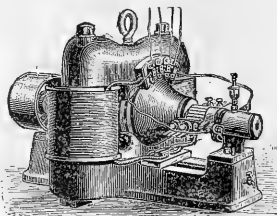

Estimates given for complete
Power Installations.

Send for Circulars and full
Information.

16 and 18 BROAD STREET, NEW YORK.

The Mutual Life Insurance Company

OF NEW YORK.

RICHARD A. McCURDY, PRESIDENT.

ASSETS - - - \$126,082,153 56

The Largest and best Life Insurance Company in the World.

The New Business of the Mutual Life Insurance Company in 1888

Exceeded \$103,000,000.

Its Business shows the Greatest Comparative Gain made by
any Company during the past year including

A gain in assets of.....	\$ 7,275,301 68
A gain in income of.....	3,096,010 06
A gain in new premiums of.....	2,333,406 00
A gain in surplus of.....	1,645,622 11
A gain in new business of.....	33,756,792 85
A gain of risks in force.....	54,496,251 85

The Mutual Life Insurance Company

Has Paid to Mutual Life Insurance Co. of N.Y. Insurance Organization \$272,481,839 82.

Arnold, Constable & Co.

INDIA PONGEES, CORAHs.

Great novelty of style and color is
to be found in these fabrics. Un-
surpassed for durability and wear.
Late importations are now being
opened.

Broadway & 19th St.

New York.

SOMETHING NEW
THE PATENT
ADJUSTABLE BRUSH.

LIQUID GLUE
ALWAYS
READY FOR USE
RUSSIA CEMENT CO.

Patent Pocket Can. No waste.

THE STRONGEST
GLUE
IN THE WORLD.
2 GOLD MEDALS
RUSSIA CEMENT CO.

Used by thousands of first-class mechanics and by such manufacturers as Pullman Palace Car Co., Mason & Hamlin Organ and Piano Co., etc., etc.

Repairs Everything.
Its success has brought a lot of imitators copying us in every way possible. Remember that THE ONLY GENUINE LePage's Liquid Glue is manufactured solely by the
RUSSIA CEMENT CO.
GLOUCESTER, MASS.
Send 10c. and dealers' card who doesn't keep it in stock, for sample.

FOOD ADULTERATION

And its Detection. With photomicrographic plates and a bibliographical appendix. By J. P. Battershall. 328 pages, 8vo, cloth. Price, \$3.50. Circulars and Catalogues on application. E. & F. N. SPON, 12 Cortlandt St., New York.

Readers of Science
Corresponding with or visiting Advertisers
will confer a great favor by mentioning the paper.

PARIS EXPOSITION.

The Cheque Bank issues Cheques, either singly or put up in Books, for the special use of VISITORS to the PARIS EXPOSITION, who can cash the same at upwards of seventy Banking Houses, situated in different parts of Paris, without charge.

Visitors' mail matter can be addressed to them, Care of the Societe Generale, 4 Place de l'Opera, opposite the Grand Hotel, where English is spoken.

Every Cheque that is issued by the Cheque Bank is EQUAL TO CASH, as Bank Notes are, for the Bank's Capital, Guarantee Fund and Customers' Balances are invested in British Government Securities, or held in Cash in the Bank of England, and can be cashed in every town in Europe without charge.

For Handbook containing list of 2,500 Banking Houses who cash the cheques, free of charge, apply to

CHEQUE BANK, Limited,
Capital, £100,000. Guarantee Fund, £27,000.
Trustees, The Right Honorable John Bright, M.P., The Right Honorable Earl Beauchamp.
NO. 2 WALL STREET, NEW YORK.

Visitors to Europe and Paris Exposition should carry a book containing Cheque Bank Cheques, which are absolutely safe and cheaper than Letters of Credit, and much more convenient; are payable on presentation without charge at 2,500 Banking Houses and 250 of the principal Hotels in Europe.

Scott's EMULSION
OF Pure
Cod-Liver
Oil
AND
HYPOPHOSPHITES
ALMOST AS PALATABLE
AS MILK.

So disguised that the most delicate stomach can take it.

Remarkable as a FRESH PRODUCER. Persons gain rapidly while taking it.

SCOTT'S EMULSION
Is acknowledged by Physicians to be the FINEST and BEST preparation of its class for the relief of
CONSUMPTION, SCROFULA, GENERAL DEBILITY, WASTING DISEASES OF CHILDREN, and CHRONIC COUGHS.
ALL DRUGGISTS. Scott & Bowne, New York.



SCIENCE

[Entered at the Post-Office of New York, N. Y., as Second-Class Matter.]

A WEEKLY NEWSPAPER OF ALL THE ARTS AND SCIENCES.

SEVENTH YEAR.
VOL. XIII. No. 330.

NEW YORK, MAY 31, 1889.

SINGLE COPIES, TEN CENTS.
\$3.50 PER YEAR, IN ADVANCE.

THE WIDDIFIELD AND BOWMAN ELECTRIC CAR-BRAKE.

AMONG the brakes tried at the Burlington brake tests in 1886, was that invented by Mr. W. P. Widdifield and A. T. Button of Uxbridge, Ontario, Can., who had a train of fifty cars equipped with their "independent momentum brake." At those tests it was demonstrated that this brake, in common with all of its competitors, developed very objectionable shocks at the rear end of long trains, owing to the fact that the brake-power could not be transmitted to the rear car quickly enough to prevent the concussion of the cars closing together. The inventors have now overcome this

working contact with the axle-pulley *C*. The pulley *e* immediately rotates, winding on its axle the chain *v*, which, through compound levers, *w* and *r*, brings the large friction-wheel *d* in frictional contact with the axle-pulley *c*, and causing it to rotate and wind upon its axle the power brake chain *s*.

Only a momentary impulse of electricity is required to apply the brake by turning the switches *Z'* or *Z''*, as the armatures of the brake-magnets are provided with a ratchet bar and pawl, *l* and *m*, which catch and hold the pulley in gear, and with a working pressure exactly in proportion to the electro-motive force of the current passed through the magnet *F*, and which can be regulated at the will of the operator. It remains in this condition until released by

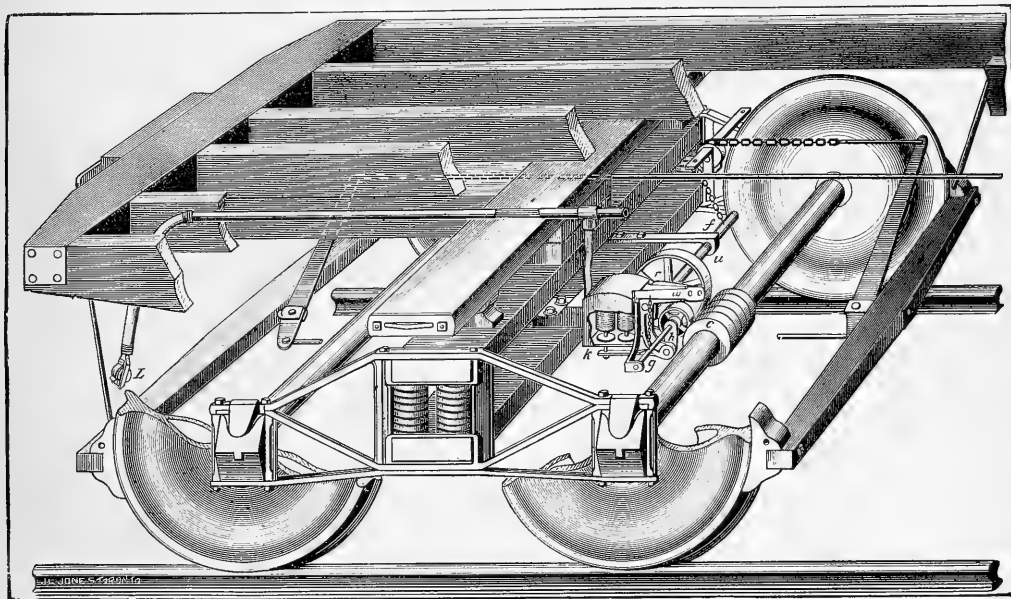

FIG. 1.—THE WIDDIFIELD AND BOWMAN ELECTRIC BRAKE.

difficulty by the use of electricity, which gives simultaneous application or release of the brakes on the longest train.

Referring to the accompanying illustrations, Fig. 1 shows the application of the brake to the truck of the car, and Fig. 2 shows the details of the operating mechanism attached to the different cars; Fig. 3 shows the arrangement of the circuits, switches, and batteries; and Fig. 4, the coupling between the different cars.

A friction-pulley, *c*, about six inches in diameter, composed of fibre and soft metal, is cast on one of the car-axes. To apply the brakes, a momentary current of electricity is passed through conductors *B* and *C* (Fig. 3), causing electro-magnet *F* (Fig. 2), through its connection with spring-lever *l*, to bring the pulley *e* in

the operator by closing the circuit through conductors *B* and *D*, and magnet *f*, the armature-core of which, *n n*, is thus drawn upward, and trips the ratchet-pawl, and thus releases the brake.

The electrical energy is supplied by a storage-battery of about 10 cells, located on the locomotive; and it is estimated that a battery having a capacity of 100 ampère hours will, in ordinary freight-train service, require charging only about once in six months. In addition to the battery on the engine, an auxiliary battery is placed on the rear car, in order that, when circumstances require it, the brakes can be controlled from the rear of the train.¹

¹ The brake and release magnets being in multiple arc, the power per car is the same, whether the train consist of one car or any number of cars.

Both brake and release circuits are normally open ; but magnets *Q* and *Q'* are in closed circuits with one or two cells, and so located that if the circuit *TB* should be broken by the train accidentally separating, the armatures *P''* and *P'''* instantly fall, and automatically close the circuits on the conductors *C* and *B*, thus applying the brake to both sections of the train automatically.

The engine plant is light and portable, and can at any time be transferred from one locomotive to another by two men in a few minutes' time.

On May 21 a trial of this brake took place on the Lehigh Valley Railway. The train consisted of fourteen empty box-cars equipped with the brake, engine, tender, caboose, and one passenger-car

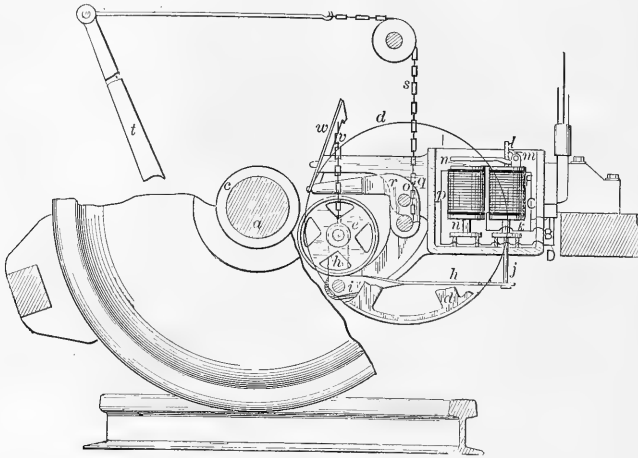

FIG. 2.

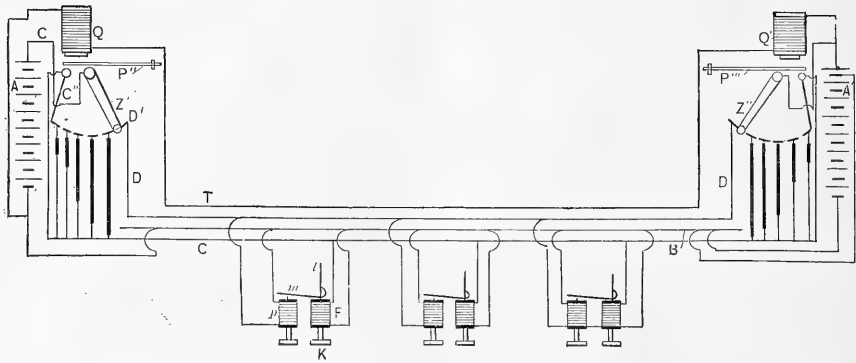

FIG. 3.

It will be seen that a very small amount of electrical energy is required, by the introduction of the compound levers and friction gear, multiplied several hundred times before it reaches the brake-beams.

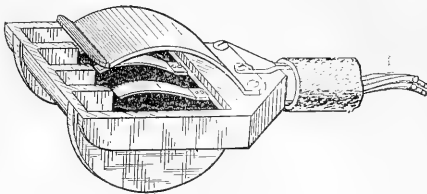

FIG. 4.

The inventors claim that this brake will perform all the functions of the air-brakes, and has the very important advantages that the train-men never lose control of it, as is the case with the air-brake, when a train is accidentally separated, and also that it will stop the longest train with no shock whatever.

without the brake. A run was made from Mauch Chunk to Slatington, a distance of eleven miles, and return. On the down trip twelve stops were made on grades varying from seven feet to forty feet per mile. The results of a number of tests were as follows : the first test, service stop for orders, smooth even stop ; second, service stop at Mr. Lentz's office, smooth even stop ; third, break-away, brakes applied automatically (speed, 25 miles), stopped in 17 seconds ; fourth, brakes applied from the top of the car (speed 25 miles), stopped in 20 seconds ; fifth, emergency stop (speed 35 miles), in 17 seconds ; sixth, emergency stop, 6 cars in front only, braked (speed, 20 miles), in 25 seconds ; seventh, long-service stop (speed, 30 miles), in 11 seconds ; eighth, slow-up to 5 miles an hour, and go ahead ; ninth, short-service stop (speed, 25 miles), in 38 seconds ; tenth, emergency stop (speed, 30 miles), in 20 seconds ; eleventh, fly cars into siding ; twelfth, emergency stop (speed, 35 miles), in 22 seconds.

The eighth, "slow-up," was a good even partial stop, with quick release of brakes, when ordered to go ahead. The eleventh, "fly car on to siding," was particularly well done, and the control of the brake-power from the caboose was very favorably commented on. The return trip was made during a shower. Several emer-

gency and service stops were made to test the brakes on a slippery rail, all of which were made with great success. The extreme smoothness of the stops, absence of shocks to rear car, the perfect control of the brakes both from the engine and caboose, were noticeable features in this test.

less than one minute per day. This is on a road about $1\frac{1}{4}$ miles long, having 34-per-cent grades, operating trains at from 4-minute to $1\frac{1}{2}$ -minute intervals (since reduced to $1\frac{1}{4}$ minutes), with a speed of 10 miles per hour. It may be doubted if any road in this or any other country can show a better record. The grips

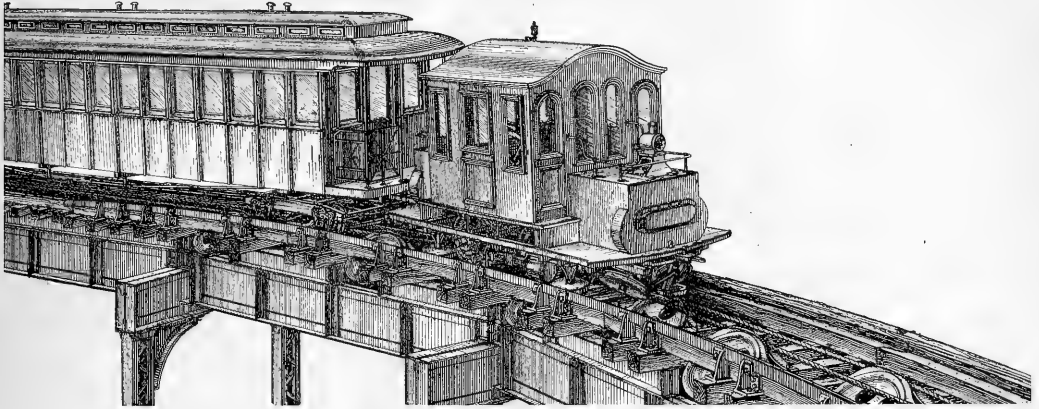

FIG. 1.—RAPID TRANSIT CABLE COMPANY'S GRIP MOTOR.

CABLE RAILWAYS.

CABLE railways have, where properly constructed, given great satisfaction, and the system has steadily grown in favor since its introduction on Clay Street, San Francisco, Cal., in 1873. The best example of a line of this character for heavy service is to be

there used consist of two pairs of packed wheels or rollers, set in frames opposite each other. Between these is a pair of solid gripping-jaws. The cable is first brought into contact with the rollers, after which the jaws come into action, and serve as a lock. This grip has these great disadvantages, however: inability to take hold

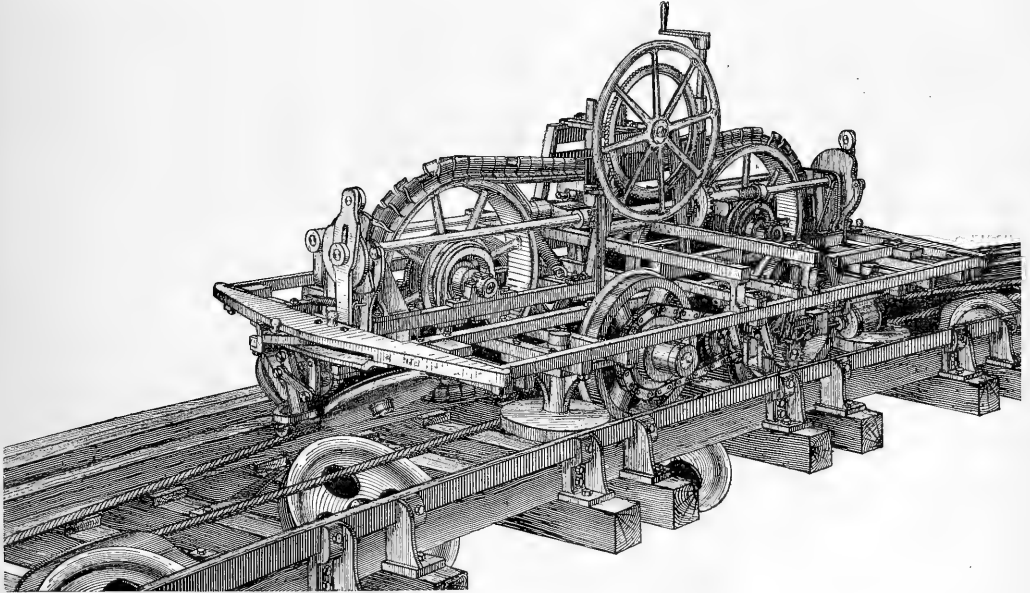

FIG. 2.—MOTOR WITH CAB REMOVED.

found on the New York and Brooklyn Bridge, over which passengers were first taken Sept. 24, 1883, from which time to May 1, 1888, 91,376,778 passengers were carried; and the delays to traffic due to the cable system amounted in the aggregate to but 20 hours and 46 minutes,—an average per month of only $2\frac{3}{4}$ minutes; or

of the cable except at certain fixed points, or to operate on curved tracks; and too small contact of the rollers with the cable; and, to exert the requisite gripping-power on the cable, it must be applied with great force, especially at the time of starting the train, when the greatest power is required. This "pinch" on the cable

is destructive to the strands, and the solid jaws are brought into action too quickly; yet the first cable was in continuous use from the opening of the railway to Nov. 7, 1886, and the second was

3. Can a sufficiently powerful grip be devised to haul the heavy trains in use on elevated railways, provided the ability to grasp the cable is demonstrated?

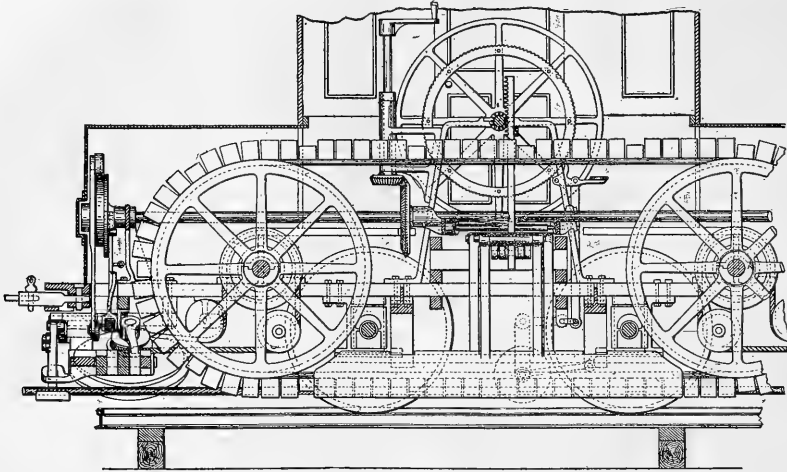

FIG. 3.

still serviceable in April, 1888, while the roller-packing gives a service of 20,000 miles.

But grips on each car, and ten miles per hour, regardless of its inapplicability to curved lines or inability to take hold of the cable, would not answer for elevated railways; and a cable moving at a

4. Will any saving be effected in operating expenses by substituting cable and stationary engines for the system now in use?

To each and all of these questions the Rapid Transit Cable Com-

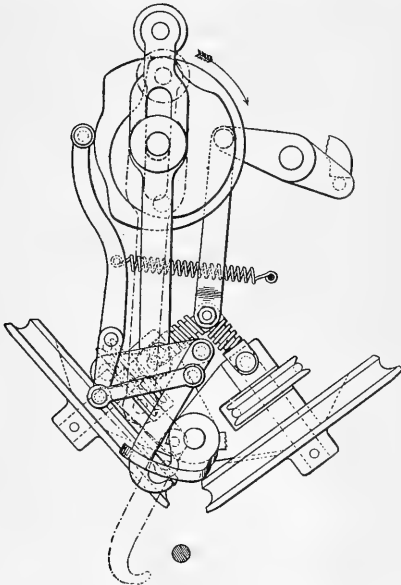

FIG. 4.

greater speed would, if brought into contact with such rollers, very soon destroy the packing.

1. Is it, then, possible to run a cable at sufficient speed to provide rapid transit?

2. Is it possible, provided the required speed can with safety be obtained, to grasp the cable with any effective gripping-device without great destruction to either cable or grip, or both?

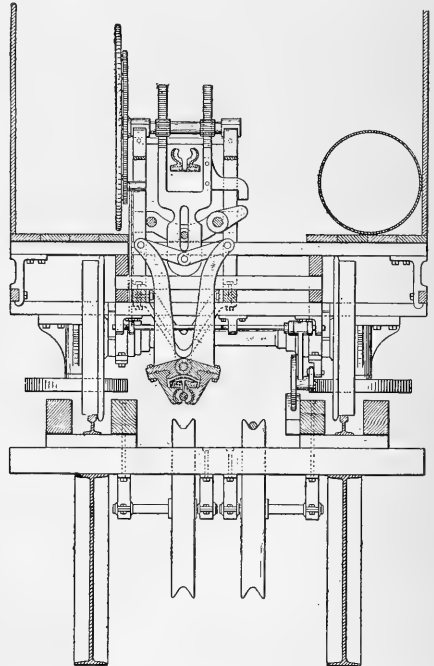

FIG. 5.

pany of New York reply in the affirmative, and endeavor to prove their position as follows:—

1. The present elevated railways in New York are operated at an average speed, including stops, of 12.18 miles per hour, or 17.86

feet per second; express-trains, 18.23 miles per hour, or 26.74 feet per second. Allowing for station stops, the maximum speed will be under 20.5 miles per hour, or 29.9 feet per second.

The speed at which a cable for the transmission of power can be run may be determined by the liability of the pulleys to burst under

brakes are brought into action, and the pulling-power of the cable gradually overcomes the inertia of the train.

3. In answer to the third question it is sufficient to state that the length of the gripping-surface is 60 inches, which, used with a cable of $1\frac{1}{4}$ inches diameter, and assuming only three-fourths of

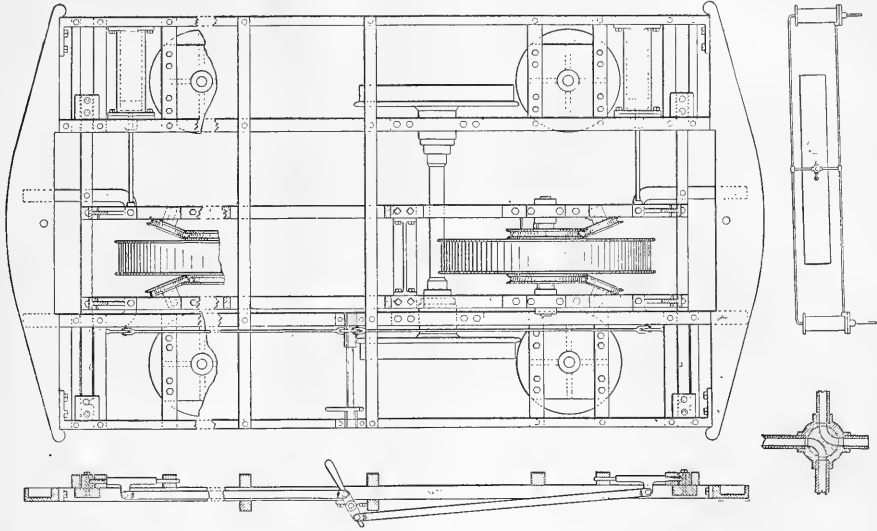

FIG. 6.

the action of centrifugal force, and this safe speed is determined by Professor Unwin, for cast iron of 4,500 pounds per square inch tensile strength, to be 215 feet per second; so that, if we adopt 25 miles per hour as the desired velocity, which is nearly one-fourth greater than now used, we shall have for our working speed 36.66 feet per second, or about one-sixth of the safe limit for cast-iron pulleys. Hence there can be no question as to speed.

2. To one familiar only with the cable grips at present in use, it is but natural that this second question should cause considerable apprehension, for there is not one which could be successfully used for such velocity as has been above assumed. But the Rapid Transit Cable Company have had this question of providing a gripping-apparatus applicable for heavy trains and high velocity constantly in view, and their experiments and labors have been largely devoted to overcoming the difficulties encountered; in fact, it may be said to have been a *sine qua non*, and they are at last prepared to claim a successful solution of the problem. Their grip for such service as is now under consideration is placed on a separate truck or car, and hauls the train as a locomotive; but instead of weighing 23½ tons, concentrated as largely as possible on four driving-wheels, it weighs less than 10 tons; it is supplied with pumping-cylinders to provide compressed air or vacuum for operating train-brakes, and for moving itself about yards or switching from one track to another. Curves of any radii which are practicable for any other motive power are passed with equal facility, and the cable can be picked up at any and all points on the line. It is arranged for duplicate cables, as is also the driving-machinery, so that in case of any accident the idle cable may be picked up without a delay exceeding five minutes, wherever the trains may be. The gripping-device gives a very long contact, thus reducing the unit pressure on the cable for a given weight of train. The gripping surface is of leather; and, to still further protect the parts in contact from excessive wear, a very simple device sets the movable gripping-parts into motion automatically before they are brought into contact with the moving cable. Thus that which in all other grips would be speedily cut out by the cable is in this case preserved, and little or no cutting can take place. When the parts are moving at the cable speed, the pressure is applied, the grip-

periphery to be subjected to the gripping-pressure, will give an available area of 246 square inches. The friction of leather on a cable may safely be taken as 0.6 of the pressure applied, so that for every pound of pressure there is 0.6 of a pound of pulling-power. An elevated-railway locomotive with 37,400 pounds on

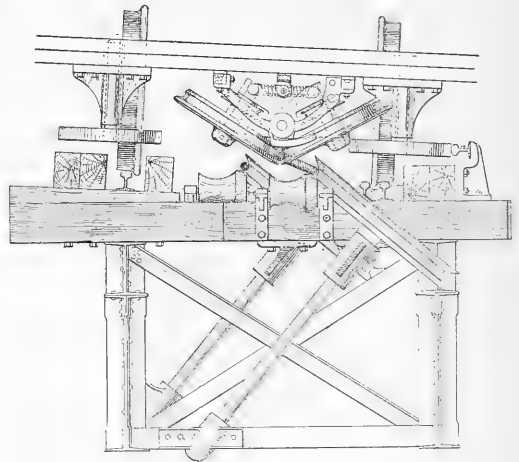

FIG. 7.

drivers, may, under the most favorable conditions, exert from one-third to one-fourth of this weight as tractive force, an average of 11,400 pounds, which this grip will produce with less than 78 pounds per square inch, which may be multiplied several times without injury to cable or grip.

4. Next as to the question of economy. In a cable system,

water and coaling stations are unnecessary; less water is needed, less oil and waste, and from one-half to one-third the quantity of coal, which may be of an inferior quality, costing perhaps one-half of what is now paid. Grades cease to be obstacles, and expensive constructions like that in New York at 110th Street and Eighth Avenue become unnecessary, and stations are made more accessible. It is clear that to stop five-car trains weighing 100 tons, with engine $23\frac{1}{2}$ tons (together $123\frac{3}{4}$ tons), requires more braking-force

trains of the Manhattan Elevated Railway of New York City travelled a total of 7,202,966 miles during the year ending Sept. 30, 1887, carrying 158,783,241 passengers. The expense of operating the road for the same period was \$4,508,467, being 61.89 cents per train-mile run, or 2.79 cents for each passenger. A carefully prepared table of the work done by the cable-road on the New York and Brooklyn bridge for the year ending May 31, 1887, shows a total of 877,496 train-miles run, and 26,388,808 passengers carried.

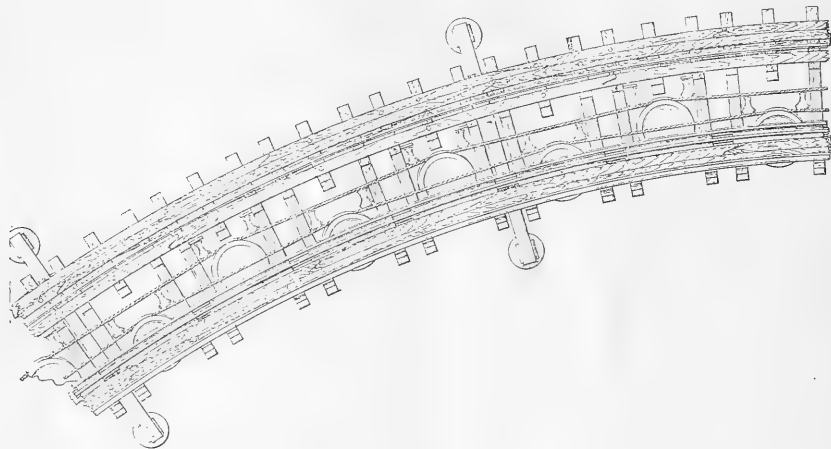

FIG. 8.

than the same train of cable-cars with a 10-ton motor, a total of 110 tons; it is also evident that the lighter train will attain full speed more quickly. The horse-power of a locomotive is least at starting, just at the time when the greatest effort is needed; whereas with the cable-train the motive power (the cable) is already in full speed, with the power of the enormous driving-engines ahead of it. It is a question in cable-traction how to come into full speed slowly enough; and therefore, to be entirely successful, a cable-road requires the most perfect differential grip.

The operating expenses were \$402,894, being 45.84 cents per train-mile, or 1.52 cents per passenger. In this particular instance it would appear that the cost of carrying each passenger on the cable-road was less than half that on the steam-road, while the cost per train-mile run was at least one-fifth less on the former than on the latter.

In Fig. 1 the Rapid Transit Cable Company's motor is seen respectively, coupled to a train; and in Fig. 2 it is represented with the cab removed.

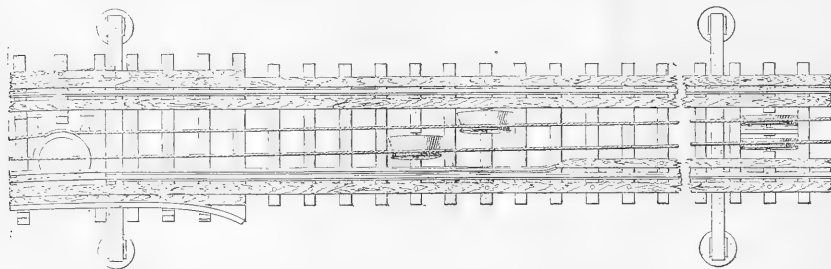

FIG. 9.

As to the amount of power expended in driving the plant, reference is made to Mr. Leverich's paper on the New York and Brooklyn Bridge, wherein it is stated that the highest horse-power developed by the engines was 394.5, and that to drive the plant alone, cable included, required 47.7 horse-power, which gives 87.99 per cent to be utilized for cars and passengers.

A comparison of the motive-power expenses of cable and locomotive roads may be made from recent reports. According to the report of the railroad commissioners of the State of New York, the

Fig. 3 is a partial longitudinal section on a broken plane, in which is shown the revolving belt of clips, with inner surfaces of leather, between which the travelling cable is held; and the large capstan-wheel for applying and releasing the gripping-jaws, through which the belted clips run (as shown in dotted lines), and are forced with greater or less pressure against the cable, thus retarding the belt proportionately from the consequent friction of the outer metallic plates of the clips in contact with the metallic guide and gripping-jaws. This produces a greater or less differential

speed of the revolving belt and travelling cable to the speed of the motor, and thus enables a gradual start or variable train-speed without injury to the grip or cable. To the left of the capstan-wheel is a vertical shaft having on top a crank with handle or a wheel, and terminating below in a bevel-gear wheel which engages with another keyed to the long shaft, by means of which the pick-up is operated, as well as the carrying-sheaves at the end of the motor, which serve to properly guide the cable in its relationship to the revolving belt, and cause it to revolve at the same speed as the travelling cable, before their contact. These are all very simply and positively accomplished by the continuous turning of the one crank, which, being a uniform motion, precludes any confusion of the operator.

Fig. 4 shows the pick-up and supporting wheels in detail, and their transposition when operated. Though the pick-up is capable of being worked at any time, its use is seldom required, as the cable travels through the supporting wheels almost continuously, — during stops at stations and when varying the speed, — and is seldom dropped but at crossings, ends of sections, and the termini. In dotted lines below the capstan-wheel is the automatic tripping-device to release the cable at the end of a section or at any fixed point.

Fig. 5 is a cross-section showing the shape of the clip-belt in its position between the gripping and braking jaws, which get their force from the connected compound levers and toggle, actuated by the large capstan-wheel. This grip is seen holding the right-hand cable, but may be easily shifted on its movable supporting-frame, pneumatically with cylinders, as shown in plan view in Fig. 6 (or with a capstan-bar), by the engineer or grip-man, to the centre (as required with a single cable), or to accommodate the left-hand cable (as in this duplicate system); which cable is seen supported by the end guide-wheels (previously referred to in connection with Figs. 3 and 4) in Fig. 7 in their relationship with the guard-wheels to the guard-rail and curve-carrying sheaves, Figs. 8 and 9 respectively showing the same duplicate cables in plan of track on curve, and its approach. This motor is also provided with combined air-pumps and engine-cylinders, and reservoirs.

Being adapted to a duplicate cable system that provides against the delays which might possibly occur in the use of a single cable, the grip is shifted to a position directly over the cable it is desired to take (see Fig. 6), two methods being provided in case of accident to one or the other. The horizontal crank or wheel actuating the vertical shaft (see Fig. 3) is then revolved continuously in the same direction. This causes the pick-up at each end of the motor (see Figs. 3 and 4) to descend, pass under the cable, lift it, and throw in the carrying-wheels (see Figs. 3 and 4) to support the cable in an elevated position, to be gripped by the clip-belt after the same has been put into motion by contact of the same supporting-wheels with the travelling cable; following which the pick-up is lowered slightly, and withdrawn to one side of the cable. The train can now be started and speeded with a graduation exactly as the operator may intend by the turning of the large capstan-wheel that governs the powerful mechanical combination (see Fig. 4) which actuates the braking and gripping-jaws, increasing or lessening the required tractive power, and correspondingly regulating the speed of the train without any undue exertion of the operator.

If for any reason it should be necessary to communicate with or signal to the power-house, or stop one cable and start the other, it may be done direct from the trains or motors, at any point on the line of railway, by a patent electric device; and, in the event of thus transferring the power from one to the other of the duplicate cables, the grips are shifted conformably (see Fig. 6).

THE WORK OF THE PEABODY MUSEUM OF AMERICAN ARCHÆOLOGY AND ETHNOLOGY.

THE twenty-second annual report of Professor F. W. Putnam shows that the work of the Peabody Museum of American Archaeology and Ethnology is constantly growing in importance. From the interesting contents of his report we glean the following facts.

The museum purchased for a moderate sum, from the Rev. Samuel Lockwood of Freehold, N.J., a collection of particular importance in supplementing the Abbott collection from the vicinity

of Trenton. Over thirty years ago Mr. Lockwood investigated the great shell-heap at Keyport, and was the first to call attention to its character. This shell-heap, with many of the objects from it, was afterwards described by Dr. Rau, and has become historical in American archaeology. From this large refuse-pile the most important part of the Lockwood collection was obtained. In addition, there are many stone implements from various places in Monmouth, Middlesex, Mercer, and Ocean Counties. Among them are several paleolithic implements, and a large number of argillite points, found under peculiar conditions, and showing a degree of weathering which is conclusive evidence of their extreme antiquity. As the shell-heap at Keyport, once covering a mile or more in length along a narrow strip, bordered upon one side by the ocean and on the other by Raritan Bay, is entirely obliterated, it is of importance that the materials obtained from it be now in the museum for comparison with the very extensive collections from the shell-heaps of New England. The fact that at certain places on this narrow strip between the bay and the sea the prevailing implements were of argillite and of great antiquity has a peculiar significance in connection with those from Trenton, and again points to an intermediate period between the paleolithic and the late Indian occupation of New Jersey. The collection also contains three Indian crania from Monmouth County, and a few objects from various places beyond the immediate region of Keyport. Mr. Lockwood has a considerable number of field notes, made during his long-continued explorations of the vicinity of Keyport, and it is his intention to prepare a full account of his observations and of the collection, for publication by the museum.

In the list of officers given in connection with the last report, it will be noticed that the name of Mr. Hilborne T. Cresson of Philadelphia is given as a special assistant in the field. Mr. Cresson, while studying abroad, became interested in the archaeology of France and Switzerland, and while at home has devoted his leisure time to a study of American archaeology, upon which he has published several important papers. About 1870 his attention was called to the existence of stakes or piles, observed by a fisherman, in the mud at the mouth of Naaman's Creek, a small tributary of the Delaware River. Circumstances at the time did not permit of more than a hasty examination and the taking of a photograph of the locality. It was not until Mr. Cresson's return from France, in 1880, that means were furnished, by a gentleman of Philadelphia, to prosecute the work. His examinations soon led to the discovery of three distinct localities, near to each other, which he designated Stations A, B, and C, and around which were found a very important and instructive collection of stone implements, a few points and fragments of bone, and a human tooth. At one station a number of fragments of rude pottery were found, and at this were obtained the several pile-ends now in the museum. This collection he has generously given to the museum, and proposes soon to prepare a full account of his discoveries for publication. The museum is also much indebted to Mr. A. B. Huey of Philadelphia for a number of specimens which he obtained while with Mr. Cresson during the examination of Station B, and to Mr. W. R. Thompson of Philadelphia, for several potsherds, and a large stone maul with a hole drilled through it, from the same station.

When it is recalled that this is the first indication in North America of any thing even remotely resembling the crannoge-like structures of the European bogs, the importance of Mr. Cresson's labors will be appreciated; and the museum is fortunate in having his co-operation in its work, — a co-operation which he states he freely gives from his appreciation of the objects and methods of the museum. The specimens are now exhibited in the museum, and are of great importance in the study of the periods of occupation of the Atlantic coast. The discovery by Mr. Cresson of the fact that at only one station pottery occurs, and also that at this station the stone implements are largely of jasper and quartz, with few of argillite, while at the two other stations many rude stone implements are associated with chipped points of argillite, with few of jasper and other flint-like material, is of great interest in connection with the specimens collected by Dr. Abbott and Mr. Lockwood in New Jersey, to which allusion has been made.

In connection with his studies of the river-stations, Mr. Cresson has examined the peat marshes and land along the shore of the

Delaware, and has obtained stone implements from various points, both personally and by interesting friends and residents in the work he was engaged upon. He has also made a collection to show the character and relation of the peat to the river-deposits, and in various ways has made a thorough study of the connection of the river-stations with the early inhabitants of the shore.

Mr. Cresson's investigations have also been carried on in relation to the paleolithic implements found in the gravel, and he has been so fortunate as to discover two specimens *in situ* in the older gravel near Claymont, Newcastle County, Del. He also, in company with Mr. Thompson, made a visit to Indiana, and examined the gravel on White River above Medora in Jackson County. Here he was so fortunate as to find a large paleolithic implement of gray flint, in place in the gravel of the bluff of the east fork of White River. A rudely chipped implement, probably of later date, was also found in the gravel about a mile distant from the first, and was presented to the museum by Mr. Thompson.

Mr. Cresson has prepared a full account, which will soon be printed, of the discovery of these implements. In the mean while it is only necessary to call attention to the importance of these discoveries in relation to the distribution of paleolithic man in America. The value of the material for this purpose cannot be over-estimated, containing as it does nearly all the implements known from the New Jersey gravels, in the Abbott and Lockwood collections, the two specimens from Delaware and one from Indiana in the Cresson collection, the two from Ohio found by Dr. Metz, and the Babbitt collection from Minnesota. For comparison with these, the museum has numerous specimens from the gravels of France and England.

Professor Putnam's remarks on the results of his researches on the Serpent Mound will be read with interest. He says, —

"We have discovered many facts pointing conclusively to considerable antiquity in the occupation of the region about the Serpent Mound. We know historically that a hundred years ago the region was inhabited by Indians, and we have found graves that probably belong to that time, or immediately preceding it, and we have also found another class of burials having every indication of far greater antiquity. Here upon the Serpent Mound Park, the property of the museum, and not far from the Serpent, are three burial-mounds with two entirely different methods of burial. Here are a village site and a burial-place occupying the same area. A recent and an early period are everywhere evident as the exploration goes on. Every thing relating to the construction of the great earthwork points to antiquity. The signs of the later occupation of the region about it have nothing remarkable: simple ash-beds where the dwellings stood; burials in the black soil, with or without protecting stones about the graves; no elaborate structures or indications of special ceremonies in connection with the burial of the dead; intrusive burials in a conical burial-mound; — every thing, on the one hand, pointing to a recent and not long-continued abode upon the spot; on the other hand, antiquity and special ceremonies; — a conical mound of considerable size, erected as a monument over the body of a single person, buried after some great ceremony in connection with fire; another mound under which were four graves (one deep down in the clay under many large stones; three others over this, with large stones about the graves and over them, and a mound of earth over all); in another instance a grave deep in the clay, with flat stones at the bottom, upon which the body was placed, and over the body many large stones, covered by the black soil of recent formation; and in this black soil, over the stones, a grave of the later period; in another place, under the black and recent soil, stones irregularly placed upon the clay, marking graves, or places where fires were made; two and three feet under these once surface-piles of stones, the graves, with skeletons so far decayed that only fragments could be secured (in several instances only the outlines of the bones could be traced in the clay; in some cases the bones in part were preserved by the infiltration of iron, and the crevices in the clay about the bones were filled with limonite, — all showing great antiquity in contrast to the more recent burials). These older burials were made in connection with ceremonies during which fire played an important part, as shown by the burial of ashes and burnt materials with the bodies, and also by the stone fireplaces near the graves.

In several of these ancient graves, objects were found similar to those which we have obtained in the ancient mounds of other parts of the State. In the recent graves, with the skeletons just under the recent black soil, only now and then an arrow-point of flint or a stone celt was found, with fragments of rude pottery, such as are distributed over the surface of the village site. In the ancient graves not a fragment of pottery was found. In one of the oldest graves containing two skeletons were nearly fifty stone implements and several ornaments, among them one cut out of a crystal of galena.

"Of the two periods, our explorations have shown that it can hardly be questioned but that the Serpent Mound was built by the people of the first, that it was connected with their beliefs and their ceremonies, and that in its sacred precincts some of their dead were buried.

"This seems to be the legitimate conclusion reached by our work to this time. I shall still have time for further explorations before leaving this interesting spot, and there is much to be done in the immediate vicinity another year."

NOTES ON THE USE OF GRATINGS.¹

THE ghosts are very weak in most of my gratings. They are scarcely visible in the lower orders of spectra, but increase in intensity, as compared with the principal line, as the square of the order of the spectrum: hence, to avoid them, obtain magnification by increasing the focal distances instead of going to the higher orders. The distances from the principal line in my gratings are the same as the distances of the spectra from the image of the slit when using a grating of 20 lines to the inch. They are always symmetrical on the two sides, and about $\frac{1}{10}$ of an inch for the violet and $\frac{1}{2}$ of an inch for the red in a grating of 21 feet 6 inches radius in all orders of spectra. When the given line has the proper exposure on the photographic plate, the ghosts will not show, but over-exposure brings them out faintly in the third spectrum of a 20,000 grating or the sixth of a 10,000 one. They never cause any trouble, as they are easily recognized and never appear in the solar spectrum. In some cases the higher orders of ghosts are quite as apparent as those of the first order.

The gratings with 10,000 lines to the inch often have better definition than those of 20,000, as they take half the time to rule, and they are quite as good for eye-observation. They can also be used for photographing the spectrum by absorbing the overlying spectra, but there are very few materials which let through the ultra-violet and absorb the longer wave-lengths. The 10,000 gratings have the advantage, however, in the measurement of wave-lengths by the overlapping spectra, although this method is unnecessary since the completion of my map of the spectrum. By far the best is to use a 20,000 grating, and observe down to the D line by photography, using erythrosin plates from the F line down to D. Below D, cyaninè plates can be used, although the time of exposure is from ten to sixty minutes with a narrow slit. The solar spectrum extends to wave-length 3,000, and the map has been continued to this point. Beyond this, the coincidence with the solar spectrum cannot be used, but those of the first and second or second and third spectra can be.

Some complaints have been made to me that one of my gratings has no spectrum beyond 3,400, even of the electric arc. I have never found this the case, as the one I use gives wave-length 2,200 readily with thirty minutes' exposure on slow plates, requiring five minutes for the most sensitive part, and using the electric arc. With sensitive plates, the time can be diminished to one-fifth of this.

For eye-observations, a very low power eye-piece of one or two inches focus is best. This, with a focus of 21 feet 6 inches, is equivalent to a plane grating with a telescope of a power of 100 or 200.

In measuring the spectra, an ordinary dividing-engine, with errors not greater than $\frac{1}{1000}$ of an inch, can be used, going over the measurements twice with the plate reversed between the separate series. The plates are on so very large a scale, that the microscope must have a very low power. The one I use has a 1-inch

¹ From Johns Hopkins University Circulars, May, 1889.

objective and a 2-inch eye-piece. The measured part of the plate is about a foot long, the plates being 19 inches long.

All the spectrum photographs taken at different times coincide perfectly, and this can be used for such problems as the determination of the atmospheric lines. For this purpose, negatives at high and low sun are compared by scraping the emulsion off from half the plates, and clamping them together with the edges of the spectra in coincidence. The two spectra coincide exactly line for line except where the atmospheric lines occur.

This method is specially valuable for picking out impurities in metallic spectra, using some standard impurity in all the substances to give a set of fiducial lines; or, better, obtaining the coincidence of all the metals with some one metal, such as iron. Making the iron spectrum coincide on the two plates, the other spectra can be compared. This is specially possible, because the focus of a properly set up concave grating need not be altered in years of use; for, when necessary, it can be adjusted at the slit, keeping the distance of the grating from the slit constant.

The spectrum of the carbon poles is generally too complicated for use with anything except the more pronounced lines of metals, there being, at a rough guess, 10,000 lines in its spectrum. However, in photographing metallic spectra, but few of these show on the plate, as they are mostly faint. The spark-discharge gives very nebulous lines for the metals.

Most gratings are ruled bright in the higher orders; but this is more or less difficult, as most diamond-points give the first spectrum the brightest. Indeed, it is very easy to obtain ruling which is immensely bright in the first spectrum. Such gratings might be used for gaseous spectra. Short-focus gratings of five feet radius of curvature, very bright in the first order, require only a fraction of a second exposure for the solar spectrum, and the spectrum of a gas can be obtained in less than an hour. H. A. ROWLAND.

NOTES AND NEWS.

A SCHOOL for boys will open Wednesday, July 3, 1889, at North Edgecomb, Me., and will continue through the long vacation. Its primary object will be to fit boys for the college-admission examinations in the fall; but others who desire to advance in their studies, or to make up deficiencies during the summer, will there find an excellent opportunity. Especial attention will be paid to those who have been conditioned in the spring examinations. The staff of instructors will consist of four Harvard graduates, who are specialists in their several departments, and experienced tutors. The location affords good facilities for tennis and base-ball, as well as for boating, bathing, and fishing. As an experienced man will have special charge of the out-of-door sports of the students, a few boys will be received who do not wish to study, but who desire to pass the summer, or a portion of it, in a pleasant and healthful locality which combines country and seashore advantages. For further particulars, address Louis L. Hooper, Harvard University, Cambridge, Mass.

It has been announced that in the event of the final loss of the McGraw-Fiske suit, involving \$1,500,000, bequeathed to the library of Cornell, Mr. Henry W. Sage of Ithaca would pay for the library building, to cost over \$200,000, on which work has begun. But it has not been made public till now, that, in addition to standing the cost of the building, Mr. Sage offers, if the suit is lost, to give the library an endowment of \$300,000. If the McGraw-Fiske suit is won, as is confidently expected, Mr. Sage's half a million will probably come to the university for other purposes. The giving of this sum will make Mr. Sage's benefactions to the university amount to about \$1,000,000 in cash, besides counsel and services.

In the *American Journal of Science* for March, 1887, and the *London, Dublin, and Edinburgh Philosophical Magazine* for the same month, Mr. Henry A. Rowland has published a list of standard wave-lengths, as far as could be observed with the eye, with a few imperfectly observed by photography, the whole being reduced to Bell's and Pierce's values for absolute wave-lengths. Mr. Bell has continued his measurements, and found a slightly greater value for the absolute wave-length of the D line, and Mr. Rowland has reduced his standards to the new values. Nearly the whole

list has been gone over again, especially at the ends around the A line and in the ultra-violet. The wave-lengths of the ultra-violet were obtained by photographing the coincidence with the lower wave-lengths,—a method which gives them nearly equal weight with those of the visible spectrum. The full set of observations will be published hereafter, but the present series of standards can be relied on for relative wave-lengths to .02 division of Angström in most cases, though it is possible some of them may be out more than this amount, especially in the extreme red. As to the absolute wave-length, no further change will be necessary, provided spectroscopists can agree to use that of Rowland's table, as has been done by many of them. By the method of coincidences with the concave grating, the wave-lengths have been interwoven with each other throughout the whole table, so that no single figure could be changed without affecting many others in entirely different portions of the spectrum. The principal difference from the preliminary table is in the reduction to the new absolute wave-length, by which the wave-lengths are about 1 in 80,000 larger than the preliminary table. It is hoped this difference will not be felt by those who have used the old table, because measurements to less than .1 division of Angström are rare, the position of the lines of many metals being unknown to a whole division of Angström. As the new map of the spectrum has been made according to this new table, there seems to be no further reason for changing the table in the future. No attempt has been made to reduce the figures to a vacuum, as the index of refraction of air is imperfectly known; but this should be done where numerical relations of time period are desired. In the column giving the weight, the primary standards are marked S, and the other numbers give the number of separate determination of the wave-length, and thus, to some extent, the weight. Many of these standards are double lines, and some of them have faint components near them, which makes the accuracy of setting smaller. This is specially the case when this component is an atmospheric line whose intensity changes with the altitude of the sun. The principal doubles are marked with d; but the examination has not been completed yet, especially at the red end of the spectrum, and a table of the standard wave-lengths is given on p. 78 of the May number of the "Johns Hopkins University Circulars."

—Schneider & Co. of France have recently taken out a patent, as we learn from *The Engineering and Mining Journal*, for manufacturing steel containing a variable portion of copper, which is to be used in making artillery of large caliber, armor-plates, rifle-barrels, and projectiles. Ordinary copper is used for the purpose, care being taken to prevent it from oxidizing before it is mixed with the steel in the crucible; and the composition contains two to four per cent of copper, the alloy being capable of far more resisting power and more elastic and malleable than simple steel would be. This new material will also probably be valuable for making girders for building-purposes and ship-plates.

—Mr. J. S. Ames, in writing of the concave grating in theory and practice, says a word as to the difficulties of ruling gratings, which may explain why so many orders received at the Johns Hopkins University for gratings remain unfilled. It takes months to make a perfect screw for the ruling-engine, but a year may easily be spent in search of a suitable diamond-point. The patience and skill required can be imagined. For the past year, all attempts to find a point for the new ruling-engine have failed; and it is only within a few days that one has been found. Most points make more than one "furrow" at a time, thus giving a great deal of diffused light. Moreover, few diamond-points rule with equal ease and accuracy up hill and down. This defect of unequal ruling is especially noticeable in small gratings, which should not be used for accurate work. Again, a grating never gives symmetrical spectra, and often one or two particular spectra take all the light. This is of course desirable, if these bright spectra are the ones which are to be used. Generally it is not so. These individual peculiarities of gratings were fully treated by Professor Rowland in his lectures during the spring term of 1888, and have been embodied by him in a complete mathematical theory of the grating, which he has nearly ready for publication. It is not easy to tell when a good ruling-point is found; for a "scratchy" grating is

often a good one; and a bright ruling-point always gives a "scratchy" grating. When all goes well, it takes five days and nights to rule a six-inch grating having 20,000 lines to the inch. Comparatively no difficulty is found in ruling 14,000 lines to the inch. It is much harder to rule a glass grating than a metallic one; for to all of the above difficulties is added the one of the diamond-point continually breaking down. For this reason, Professor Rowland has ruled only three glass gratings, one of which has been lost, and the other two are kept in his own laboratory. These two were used by Dr. Bell in his determination of the absolute wave-length of the D lines.

— Among the interesting and successful recent inventions is a rolling-mill for producing sheet metal direct from the molten state, instead of rolling it from a billet or bar. A machine of this character has been at work for several months at the can-factory in Maywood, near Chicago. It is used for making sheet solder, six or eight inches wide, and $\frac{1}{16}$ of an inch thick, which it produces at the rate of 400 feet a minute. *The Engineering and Mining Journal* describes the apparatus as consisting of hollow rolls with cold water running through them. The water is introduced through the axles, and the rolls are of sufficient size to at once change the jet of melted metal into solid form as fast as it is fed. The powerful compression exerted by rolls upon the molten metal in forcing it between the two surfaces, and at the same time changing it to a solid body, tends to give to the sheet an even and highly finished surface. The inventors of the machine believe that the principle could be successfully applied to the rolling of Bessemer steel, as well as to softer metals. Mr. O. W. Potter, and other officers of the North Chicago Rolling Mill Company, recently examined the machine, and expressed themselves as being favorably impressed with its work.

— The *Railroad Gazette* calls attention to a double locomotive for the Indian State railways which is a novel departure from the common practice. The design is really a permanent double-header; that is, it is intended for use when the conditions are such as to require the use of two locomotives of the ordinary type, continually in tandem. This arrangement removes the necessity for two tenders, and renders easier the transmission of signals from one cab to another. There is nothing in this arrangement to criticise: it is really almost the only plan upon which locomotives of great capacity can be constructed with any approach to a minimum of weight per running foot of track. This general plan is not new in America, however. The well-known William Mason, of the Mason Locomotive Works of Taunton, Mass., constructed locomotives on this general plan many years since; and recently the South Side Rapid Transit Co. of Chicago, while investigating the possibilities of extending the usefulness of the proposed structure in years to come, decided that the adoption of a locomotive of a design similar to the one described above would enable them to haul nearly double the number of cars around the sharpest curves without increasing the load per running foot of the structure. *Engineering*, London, contains further description, together with an inset showing the locomotive quite completely.

— *Garden and Forest* states that in the garden of Professor Charles N. Shepard, Charleston, S.C., is a rose remarkable for its size and vigor. The original stock, a Banksian rose, was planted more than fifty years ago; but, at heights varying from ten to fifteen feet, grafts of Maréchal Neil, Marie Van Houtte, Devoniensis, Cloth of Gold, Madame Eugénie Verdier, and other choice varieties, have been inserted, and these have made wonderful growth. The trunk at the base is nearly a foot and a half in diameter; and the branches cover two trellises, each some forty feet long and twelve feet wide, besides rioting over a piazza sixty-five feet long and forty-five feet high, while the topmost shoots are aspiring to cover the roof. From a photograph it can be seen that this great vine was thickly covered from bottom to top with finely developed flowers.

— Our own missionaries in China frequently allude to cases of opium-poisoning, says *The Missionary Herald*. They are often summoned in haste to treat those who have by this method attempted suicide. Rev. Mr. Dixon, a missionary of the English Baptist Mission at Tai-yuen-fu, reports, that, during the three years he has been connected with the mission, he has attended

some thirty-six cases of attempted suicide by opium. He affirms that nine out of every ten men and women smoke the drug, beginning about twenty years of age, some of them earlier. The excess in this indulgence is such as to impoverish the people, and the poor wretches who are unable to obtain the supply they crave often end their sufferings by borrowing enough to destroy life. In Mr. Dixon's list of cases, there are young men and old men, girls and wives, beggars and officials. One of the occasions which frequently leads to this rash step is anger which has been excited by some trivial circumstance. Opium is an awful scourge in China, and brings in its train innumerable evils, of which, perhaps, opium suicide is not the worst.

— Four locomotives to be run by soda, which takes the place of fire under the boiler, have been built in Philadelphia, says the *Railway Age*, for service on the streets of Minneapolis, Minn., where steam-engines are forbidden. The engine is about sixteen feet long, entirely boxed in, with no visible smoke-stack or pipes, as there is no exhaust or refuse. The boiler is of copper, eighty-four and one-half inches in diameter and fifteen feet long, having tubes running through it as in steam-boilers. Inside the boiler will be placed five tons of soda, which, upon being damped by a jet of steam, produces an intense heat. In about six hours the soda is thoroughly saturated, when the action ceases. A stream of superheated steam from a stationary boiler is then forced through the soda, which drives out the moisture, and the soda is ready for use again. The exhaust steam from the cylinders is used to saturate the soda, and by this means all refuse is used. These engines are the first of their kind that have been built in this country. They will have the same power as those used on the New York elevated roads. Soda-engines are used in Berlin and other European cities very successfully, and they also traverse the St. Gothard Tunnel, under the Alps, where the steam-engines cannot be used, because the tunnel cannot be ventilated so as to carry off the noxious gases generated by a locomotive.

— In 1864 a hot-headed French inventor offered to contract for churches and cathedrals, including a peal of bells, says *The Paper Makers' Circular*, to be constructed entirely of paper. From chimes to cannons was but one step, and the Gallic inventor announced his readiness to supply a train of artillery of any given caliber, made of the same material. Building-paper is enjoying a perfect boom just now, and is proving a fine material in the hands of architects and builders for several uses, inside and out. The advantages, briefly stated, are: continuity of surface, or its adaptability for making into rolls of almost any width and length, and flexibility; or by gluing several layers together it may be made stiff, and will stop the passage of air because of the absence of joints; unlike wood, it has no grain, and will not split; it is unaffected by change of temperature, and thus has an advantage over sheet-metal for roofing materials; though in its natural condition it is affected by moisture, it can be rendered waterproof by saturating with asphalt or by various other methods; being a non-resonant body, it is well fitted to prevent the passage of sound; it is a non-conductor of heat, and can also be made of incombustible material, like asbestos, or rendered resistant to fire by chemical treatment.

— The electrical census machine is described as follows in *The Engineering and Mining Journal*: "The census-collector will call with his printed blank, and answers to questions will be written in the usual way. These sheets will then be placed before a person who operates a machine which may be likened to a typewriter, except, that, instead of the usual ink-mark on paper, small round holes are punched in a card. The cards, one for each person, are about $6\frac{1}{2}$ inches in length by 3 inches in width, and the particular position of a hole in a card indicates an answer to some of the questions in the printed blank. As many as 250 items of information can be punched out upon a card, although no one card would ever have more than one-tenth part of the whole number: as, for example, no one person can be classed as both white and black, American and foreign born, and if foreign born he can only come from one country. These cards, when punched, are placed one at a time in a sort of press, and a lever operated by one hand is brought down, when a series of pins are brought against the

card. Whenever a hole has been punched in a card, the corresponding pin passes through into a mercury-cup beneath, completing an electric circuit. These circuits, one for every hole, pass out to a large number of counters which operate electrically, and which add upon their dials all items of the same kind upon the same dials: as, for instance, all white men upon a dial marked "white males;" all business or professional people, upon dials which indicate their particular business or profession. The cards, as they leave the press, are all sorted by means of an electrical sorting device, whereby they may be separated into groups or States of the Union. It will thus be seen that the machines are much more reliable than the most accurate human agency, and that one machine will do the work of a large number of clerks. The next census of this country will be taken with these machines, and two will be sent to New York soon for the 1890 census-taking."

—The report of the royal commission appointed to consider the expediency of establishing a teaching university for London has been laid on the table of the House of Commons, and *Nature* states that the Blue Book may be expected soon. The commissioners are agreed, first, that the petition of the Royal Colleges of Physicians and Surgeons to be authorized to grant degrees in medicine should not be entertained; second, that it is desirable that London should have a teaching university. On the third point—whether a charter shall be granted to the associated colleges of King's and University, constituting these colleges the Teaching University of London—the commission are divided. The three commissioners connected with the teaching profession (Sir William Thomson, Professor Stokes, and Mr. Welldon) are in favor of it; the three lawyers (Lord Selborne, Sir James Hannen, and Dr. Ball) are opposed to it. The report ends with a request that this question be referred back to the commission for their further consideration, in order that they may determine whether it is not possible to devise a scheme of common action between the two colleges and the existing University of London.

—The Swedish Government has decided, *Nature* announces, to send a man-of-war to New York to bring home the body of Capt. Ericsson, who expressed a strong desire to be buried at Langban-shytan, in Vermeland, the place of his birth. In his will no directions are given as to the disposal of his valuable collection of models, but Swedish journals state that the executors will present them to the Smithsonian Institution.

—According to *Allen's Indian Mail*, the Madras Museum now possesses the skeleton of the largest elephant ever killed in India. This elephant was the source of great terror to the inhabitants of South Arcot, by whom it was killed and buried. The museum authorities despatched a taxidermist to the spot to exhumate the bones and transfer them to Madras. The skeleton is exactly 10 feet 6 inches in height, being 8 inches higher than the highest hitherto measured in the flesh by Mr. Sanderson.

—The Upsala University and the Swedish Geographical Society have sent Dr. Carl Forsstrand to study the marine fauna of the West Indian Islands during the present summer.

—Mr. Chardonnet has succeeded in preparing a new artificial silk,—a silk which bears the same relation to the natural article as celluloid does to ivory. Its preparation is somewhat as follows: Cellulose (cotton, or whatever may be available), after being treated with a mixture of nitric and sulphuric acids in equal proportion, as for the making of gun-cotton, is dissolved in a mixture of alcohol and ether, to which is added some perchloride of iron or protochloride of tin and tannic acid. The solution thus obtained is placed in a vertical vessel terminating in a small tube or in a diaphragm pierced with fine holes, so that it can run out into a vessel full of water slightly acidulated with nitric acid. The fine fluid filament which comes out takes on immediately a more or less solid consistency, and forms a thread, which can be wound on a spool. The thread thus obtained resembles silk very closely, and is equally strong and elastic. It is not attacked by water, cold or warm, nor by the acids and alkalis moderately concentrated. By introducing into the solution coloring-materials, one may obtain threads of

any desired shade. This artificial silk is said to be extremely inflammable,—an objection which it is hoped to overcome. It is probable that the nitric acid can be replaced by some other which will render it less combustible. When this progress has been realized, we shall have a new textile fabric of the greatest importance.

—Madrid has for a long time shared with St. Petersburg and Buda-Pesth the monopoly of being one of the most unhealthy cities in Europe. From 1880 to 1887 the number of deaths averaged 41.2 per thousand. In 1887, on account of epidemics of scarlet-fever and diphtheria, this figure rose to 45 per thousand. As a result, the public and the authorities have been aroused, and the government has just ordered certain measures to improve the sanitary condition of the city, including improved drainage systems, methods of disinfection, the inspection of the food-supplies, the organization of proper hospitals, etc.

—Laura Bridgman, the famous deaf and blind mute, died May 24 in the Perkins Institution for the Blind in South Boston, of erysipelas, which finally attacked the heart. She had been ill for about three weeks, and retained her consciousness almost unto the last. The story of her afflictions, and of the wonderful way in which she was enabled to triumph over them, had made her name known throughout the civilized world. She was born in Hanover, N.H., Dec. 21, 1829, and, although subject to fits in infancy, was an intelligent and healthy child, with all normal faculties, at two years old. At that time she was prostrated by a fever, which raged for seven weeks, destroying sight and hearing, and blunting the senses of taste and smell. She did not recover her health for two or three years, and was cut off, necessarily, from all ordinary human communication, although she exhibited signs of intelligence, and proved her recognition of different members of her family by certain motions which she herself invented. She was seven years old when she was put under the control of Dr. Samuel G. Howe in the institution of which she remained an inmate for so many years, and her education was begun.

—A writer in the *Pall Mall Gazette* says, that, including five drowning cases, the fatal accidents from all causes in connection with the Forth Bridge amount to 53. As regards those killed in the actual construction of the bridge, there have been 44 lives lost, death taking place either at the time of the accident or soon after. The total number of accidents which had occurred up to September, 1888,—mostly in the four years beginning with September, 1884,—was 543, of which the greater part, of course, were of the description ranging from "serious" to "slight." Of these 543 cases, 84 were treated in hospital, and 459 at the homes of the injured persons. The following hair-breadth escapes are recorded: One man trusted himself to work at a height of 120 feet over the waters of the Firth, simply grasping a rope. His hands got numbed with cold, his grasp relaxed, he fell backwards down, and down, into the water; and he was fished up alive. In another instance a spanner fell a distance of 300 feet, knocked off a man's cap, and fell on the wooden stage at his feet, and went clean through a four-inch plank. In another case somewhat similar, a spanner which fell from a great height actually tore a man's clothes from his waistcoat to his ankle, and left him uninjured. One of the most thrilling incidents heard of was that in which the "staging," or scaffolding on which the men work high up in mid-air, gave way, carrying a number of poor fellows in its fall. Two of these men, striking some portion of the work in their descent, were killed before they reached the water; one or two others who fell clear of the girders were rescued from the Firth little the worse for their fall and immersion; two others, however, managed as they fell to grasp at one of the struts high up above the water, and there they clung for dear life. To effect their rescue was itself an undertaking of no slight danger; but efforts were promptly made, and before long the man who happened to be nearest the rescuer was reached. And this brave fellow, hanging there to the ironwork, actually persuaded the rescuers to delay taking him off before they saved his companion. "Never mind me!" he said: "I can hold a bit longer; go and see to my mate, for he's getting dazed, and he'll drop." We are glad to record that this hero, and his mate too, were saved.

SCIENCE:

A WEEKLY NEWSPAPER OF ALL THE ARTS AND SCIENCES.

PUBLISHED BY

N. D. C. HODGES,

47 LAFAYETTE PLACE, NEW YORK.

SUBSCRIPTIONS.—United States and Canada.....\$3.50 a year.
Great Britain and Europe..... 4.50 a year.

Science Club-rates for the United States and Canada (in one remittance):

1 subscription 1 year..... 8 3.50
2 " 1 year..... 6.00
3 " 1 year..... 8.00
4 " 1 year..... 10.00

Communications will be welcomed from any quarter. Rejected manuscripts will be returned to the authors only when the requisite amount of postage accompanies the manuscript. Whatever is intended for insertion must be authenticated by the name and address of the writer; not necessarily for publication, but as a guaranty of good faith. We do not hold ourselves responsible for any view or opinions expressed in the communications of our correspondents.

VOL. XIII. NEW YORK, MAY 31, 1889. No. 330.

CONTENTS:

THE WIDDIFIELD AND BOWMAN	EDITORIAL.....	422
ELECTRIC CAR-BRAKE..... 411	Sanitary Condition of Paris.— Horse-Flesh as Food in France.	
CABLE RAILWAYS..... 413	BAKING-POWDERS.....	422
THE WORK OF THE PEABODY MUSEUM OF AMERICAN ARCHAEOLOGY AND ETHNOLOGY..... 417	THE MINERAL WEALTH OF BRITISH COLUMBIA.....	426
NOTES ON THE USE OF GRATINGS H. A. Rowland 418	AMONG THE PUBLISHERS.....	429
NOTES AND NEWS..... 419	LETTERS TO THE EDITOR. Fog. H. A. Hazen 429	

NOW THAT THE PARIS EXPOSITION is attracting a great crowd of strangers to Paris, it is not without interest to note the excellent sanitary condition of that city. The mortality has at no time this year reached so small a figure as in the week ending May 4. The average for this week in the past five years has been 1,122. This year the mortality was only 984; and in the week following, it fell to 951. Typhoid-fever especially has shown, since 1888, a constant decrease. More than all others, this affection belongs to the list of diseases which may be avoided; and it is only necessary that there should be due energy on the part of the public authorities to reduce its frequency in a notable proportion. While typhoid-fever and varioloid have decreased, it is unfortunate to note that this is not true of measles and of diphtheria. This results, no doubt, from the fact that the measures which can stay the progress of these diseases depend more upon individual initiative than on public measures. Among the causes which may explain the improved health of Paris may be noted the increased use of the conveyances which are placed by the police at the disposal of those wishing to transport persons suspected of being affected with contagious diseases. In 1886 these carriages were called for only at the rate of thirty to forty per month. In 1888, in the month of April, this number had increased to 211; and in the April just passed, to 231. Another cause acting beneficially is doubtless the improvement in the quality of milk,—an improvement due to the constant control exercised by the city laboratory.

IN 1856, ISIDORE GEOFFROY-SAINT-HILAIRE, in a work of considerable importance on food-substances, and in particular on horse-flesh, wrote, "There are millions of Frenchmen who never eat meat, and each month there are millions of kilograms of good meat all over France turned over for industrial uses of secondary importance, or even thrown away." Since that time, and in a great measure as the result of the persevering efforts of Mr. Decroix, a retired military veterinarian, and to-day the honorary president of the Society for the Prevention of Cruelty to Animals in France, horse-flesh has entered in every part of France into every-day use. In Paris alone the number of horses slaughtered for food-purposes has risen since 1866 from 902 to 17,256 in 1888. The greatest consumption, as is well known, was during the years 1870 and 1871; but there has been a constant increase from 1872 on. In addition to the horses consumed, there are also a considerable number of asses and mules. From Paris the use of horse-flesh has extended into the provinces, and at this time there are in all the large cities of France slaughter-houses for the purpose. The animals are no longer allowed to die of disease or of old age after their usefulness as beasts of burden has come to an end, and it is claimed that a horse twenty years old in good condition is more tender than a young one if thin and hard-used. In the Department of the Seine alone, on the 1st of January, there were 132 establishments for the slaughter of horses. The price of horse-flesh is but little more than half of that of beef for the corresponding parts; and it is claimed by Mr. Decroix that horse-flesh is more healthy and more nourishing than that of beef, and that, in equally good condition, five pounds of beef are required to give the same amount of nourishment as four pounds of horse-flesh.

BAKING-POWDERS.

HENRY B. CORNWALL, Ph.D., professor of analytical chemistry at the John C. Green School of Science, Princeton College, has, during the past year, made analyses of the different brands of baking-powders sold in New Jersey, in order to determine their ingredients, the leavening power or strength of each, and the healthfulness or otherwise of the residues left in the bread after baking. A full report of the results will be found in the "Report of the Dairy Commissioner of New Jersey for 1888." Professor Mallett of the University of Virginia has recently completed an investigation of the baking-powders in general use, and his results are reported in full in the *London Chemical News* of Dec. 7 and 14, 1888. The whole subject of baking-powders has therefore been very thoroughly examined into by two competent and disinterested chemists; and the advantages and disadvantages of the different brands duly set forth in their reports. The opinions given in the report of Professor Cornwall are based on some 55 analyses of 39 brands of baking-powders, as follows:—

	Analyses.	Brands.
Cream-of-tartar and bicarbonate-of-soda powders.....	13	8
Phosphate-of-lime and bicarbonate-of-soda powders.....	7	4
Alum, phosphate-of-lime, and bicarbonate-of-soda powders	26	20
Alum and bicarbonate-of-soda powders.....	6	4
Unclassified.....	3	3

Large quantities of inferior baking-powder were found to be sold in bulk by manufacturers. This is put up in boxes by the retailer, and a fancy label affixed, he knowing nothing about the composition of the substance, its cheapness only concerning him. During the time the samples from Professor Cornwall's analysis were being completed, it was ascertained that some of the makers and dealers in the inferior grades of baking-powders joined with their business that of lottery or gift enterprise; and plates, cups, lamps, pewter casters, and other household goods, were given away with a certain number of cans, or a can of baking-powder was given with a certain quantity of tea or coffee. It was stated in one sec-

tion of the State that one enterprising manufacturer offered a wagon with each purchase of a certain number of cans.

In commenting on this report of Professor Cornwall, the dairy commissioner, Dr. Newton, says that from inquiries made in various parts of New Jersey, and from knowledge gained in conversation with those conversant with the habits of all classes of people, he should say that the use of baking-powders is confined to the preparation of biscuits, cake, and articles other than bread. The biscuit thus prepared is usually eaten hot, and constitutes a very large portion of the dietary of the working-people. In the homes of many of the wage-workers, this biscuit made with baking-powder is the usual form of bread used for at least two-thirds of the time; fresh, yeast-leavened bread being the exception. This, of course, does not obtain in the large cities, where bread is easily bought. It may be said, without fear of contradiction, that bread made by means of yeast is by far the most satisfactory and the most healthful of all the preparations of flour. It contains no residue about which there can be any controversy, it contains no added chemical; it retains, with but little change, the nutritive elements of the flour. Hence, while baking-powders may answer for occasional use, they cannot be recommended as a complete substitute for yeast, as their action is different from and the product dissimilar to that obtained from fermentation.

A baking-powder should answer to all of the following requirements: 1. It should generate the maximum amount of gas; 2. It should contain no unhealthful ingredients; 3. It should leave in the loaf no unhealthful residue; 4. The elements should be combined in such proportions that the residue is neutral in re-action.

Dr. Newton further says that the evidence is conclusive, and certain points to these facts: that alum residue does affect digestion, and that these residues are more or less soluble, and are carried into the system. Hence it is suggested, that, if any person wishes to avoid a possible danger to health, he should refuse to buy alum-powders. It must be stated, however, that the evidence in the case is not as strong as with other chemical agents, and we cannot speak of the results following the constant ingestion of small quantities of the soluble alum compounds with the certainty that we do when considering lead and other toxic agents, which are poisonous when taken in very minute quantities and continuously. All that he can do officially, while there is yet doubt on this question, is to give the public the benefit of that doubt, and advise the use of these preparations with great caution until the problem is positively settled by experiments on the lower animals. As will be seen by reading Professor Cornwall's paper, some alum combinations are known to be dangerous to health: these he has indicated. He cautions the public that baking-powders sold by weight, and without any name on the package, are to be avoided, as any manufacturer responsible for his preparations will not be ashamed to print his name on the label.

In the introduction to his report, Professor Cornwall remarks, that although nothing is so well adapted as yeast for making a palatable and digestible bread, yet their greater convenience or the necessities of the case may sometimes be a reason for using baking-powders even for making bread, and they are very largely used in preparing various articles of food which largely take the place of bread. It becomes, therefore, a very important question to determine the probable effects of the many different kinds of baking-powders on the health of the consumer.

He explains the action of baking-powders as follows: The baking-powders render the bread¹ light, through the action of gas set free in the dough. This gas is almost exclusively carbonic-acid gas, the carbon dioxide of the chemist. The carbonic acid is set free from bicarbonate of soda by the action of some acid substance, which yields a part or the whole of its acid to the soda, thereby expelling the carbonic acid.

Carbonate of ammonia has been to some extent employed. This substance is solid at ordinary temperatures, and is converted into gas by the heat in baking, but is not alone suitable for a baking-powder, because it may easily remain to some extent in the bread after baking, imparting to it not only an unpleasant taste, but possibly, even probably, unwholesome properties.

¹ For convenience, the term "bread" will be used to include any articles made with baking-powders.

Formerly the cook made the baking-powder, when needed, by mixing in due proportions the two salts commonly used,—cream-of-tartar and bicarbonate of soda. The cream-of-tartar (bitartrate of potash) contains more of the tartaric acid than is necessary to neutralize the potash in it, and this excess of acid liberates the carbonic acid from the bicarbonate of soda. The re-action takes place only when the two salts become dissolved in the dough, and these salts were especially adapted to the purpose because they dissolve but slowly; so that there is a continual and gradual liberation of the gas, keeping the bread light until the baking is finished. Bicarbonate of soda is better than simple carbonate, also, because it yields twice as much gas.

There were serious objections to the old-fashioned process. Apart from impurities in the salts, which are quite as prevalent in some of the modern baking-powders, the cook needed to exercise unusual care in measuring the two salts, so as to avoid getting too much of one or the other; and quite as great care was needed to thoroughly mix the two, so that they might exercise their full action on one another, without which the familiar yellowish or brownish "soda" spots would be produced. A really well-made baking-powder obviates all the evils resulting from these causes, as well as from the use of impure or deteriorated materials.

The requisites of a good baking-powder are (1) that the ingredients, in the quantities used, shall not injure the health of the consumer; (2) that the powder shall yield the largest amount of gas that can be obtained from wholesome ingredients, and in such a way as to produce the best effects (boiled with water, it should give a neutral or very nearly neutral solution); (3) that the powder shall keep its strength, and also not cake or become lumpy under the ordinary conditions of storage and use.

The caking of the powder is due to the fact that some of the active ingredients are often of such a nature as readily to absorb moisture from the air, so that they partly dissolve, and not only cause caking, but also loss of "strength" through the escape of carbonic-acid gas. This evil is greatly reduced by the use of well-dried materials, and by the addition of dry starch-powder, wheat-flour, or similar farinaceous substance, so that a well-made powder loses very little strength. In good cream-of-tartar baking-powders, about twenty per cent of such a "filling" body is often used. More than this is unnecessary, and simply lowers the cost of the product. A little less is sometimes used. In the majority of alum-powders the strength is only one-third or one-half what it might be; and in many cases this is, no doubt, due to excess of the starch or flour thus sold at the price of baking-powder. It may be argued that the strength of the powders is purposely kept down to a standard that will permit the use of the customary "two teaspoonfuls."

The statements on labels, that a powder "is made from pure ingredients," has little significance, unless the ingredients of the powders are also given. An alum-powder may be made of pure alum; a mixed powder may contain pure bisulphate of soda and pure tartaric acid; even an acid-phosphate-of-lime powder may be made of pure materials, so far as concerns the addition of any adulterant by the compounder, and yet the acid phosphate may be full of sulphate of lime, originally present in it by the nature of the process of manufacture. Thus, a maker of baking-powder might be sending out an article containing much *terra alba* (sulphate of lime); and yet, because he knew he had not put in any *terra alba* as such, he would claim that his powder was pure.

Cream-of-Tartar Powders.

The cream-of-tartar itself is a natural constituent of grape-juice, and probably no material has ever been devised for making baking-powders that is open to less objection than cream-of-tartar, unless possibly the acid phosphates.

Acid-Phosphate-of-Lime Powders.

The acid phosphate of lime (also called superphosphate of lime) has of late been much used in baking-powders, and there seems to be no physiological objection to its use. Indeed, it is claimed that its use restores to the finest wheat-flour the phosphoric acid which is so necessary to our health, and which has been in great part removed with the bran. Other acid phosphates have been to some extent employed, but the acid phosphate of lime far the most

widely. Unless properly prepared, the acid phosphate may not be so unobjectionable a substance. It is made by acting upon ground bones with sulphuric acid. The result is sulphate of lime and the acid phosphate of lime. If, now, the latter, which is freely soluble in water, is leached out, leaving the sulphate of lime behind, we have the acid phosphate in fit condition to be used. It is mixed with starch, dried, and brought into the market as a cream-of-tartar substitute. Frequently, however, the sulphate of lime is left with the acid phosphate, and will then bring about any ill effects that may justly be attributable to the sulphate. Moreover, unless the sulphuric acid used has been carefully purified, it may bring no inconsiderable quantities of lead, and even arsenic, into the baking-powder.

Bisulphate of Potash and Soda Powders.

Bisulphate of potash has been to some extent used in baking-powders. Its ready solubility would render it unsuitable for use alone; but, when used, it has probably been for the purpose of securing a more rapid liberation of carbonic acid at first. Used with bicarbonate of soda, it leaves a residue of sulphate of potash and sulphate of soda; and the sulphate of potash is a very objectionable substance, if present in any considerable quantity. Stillé and Maisch say of it, "Formerly used as a purgative. It is so in smaller doses than other salines. Its action is apt to be harsh and burning in the abdomen." The dose is one-fourth to one-half ounce.

The sulphate of soda (Glauber's salt) is also an active purgative, very little used in England or in this country for administration to human patients, but it is used in Germany very largely in place of our more commonly employed sulphate of magnesia (Epsom salts). The dose of sulphate of soda as a purgative is one-half ounce to one ounce, from which it appears that it is a much more active drug than Rochelle salt.

Bisulphate of soda has been used in baking-powders, in combination with other acid principles. Its action on bicarbonate of soda results in a residue of sulphate of soda. The effects of such a residue will be referred to under alum-powders.

Sesqui-Carbonate of Ammonia.

Carbonate of ammonia, used in small quantities, is perhaps unobjectionable; but probably, if any considerable quantity were employed, disagreeable physiological effects might be expected, irrespective of the unpleasant odor and taste that the ammonia compounds would impart to the bread, which always shows ammonia re-action, even when small quantities only were used in making it. The ammonia salts in general appear to be much more irritating and stimulating than the corresponding soda or even potash salts. Stillé and Maisch say of carbonate of ammonia, "It is irritant, and if long continued, even in doses which the stomach will tolerate, it impairs nutrition." In doses of five to ten grains, it increases the fulness and force of the pulse, and causes a sense of tightness in the head. It is a very powerful agent. The ordinary dose is two to ten grains. Evidently, such a substance needs to be used with care in preparing foods.

Alum Baking-Powders.

Of late years the alum baking-powders, being more cheaply made, have come into extensive use, and have met with considerable opposition on the score of qualities alleged to be injurious to the health. The alum used in this part of our country is now almost exclusively burnt ammonia alum; and, since the potash alum is more expensive, the same is probably true of alum baking-powders in general. The crystallized alums are less frequently employed, because they are too easily soluble; but they may be used in connection with the burnt alum, to secure at first a more rapid escape of carbonic-acid gas. The alumina is present in the bread, partly as hydrate and partly as phosphate of alumina, in case simple alum baking-powders are used. Where acid phosphates are also used in sufficient quantity, the alumina remains in the bread as phosphate.

Professor Mallett regards it as a fair conclusion that not only alum itself, but the residues which its use in baking-powder leaves in bread, cannot be viewed as harmless, but must be ranked as objectionable, and should be avoided when the object aimed at is the production of wholesome bread.

Tartaric Acid and Tartrates in Alum-Powders.

The makers of alum baking-powders sometimes add tartaric acid or bitartrates to their powder, either with or without the addition of acid phosphate of lime. This is doubtless done with the best intentions, either to secure a more rapid escape of carbonic-acid gas at the outset, or otherwise improve the powder. Such additions in the case of several samples have been found, but the presence of tartaric acid or tartrates in alum-powders is very objectionable. If added in sufficient quantity to otherwise pure alum-powders, they prevent the precipitation of the insoluble hydrate of alumina entirely when the powder is boiled with water, and they may render much of the alumina soluble in water even after the bread is baked. Without doubt, it would then be readily soluble in the digestive organs, producing there the effects due to alum or any other soluble aluminum compound. Not even the boldest advocates of alum-powders have denied the injurious tendencies of soluble aluminum compounds in the bread.

Acid Phosphates in Alum-Powders.

The addition of acid phosphate to alum-powders can only be regarded as an improvement, provided the acid phosphate is free from sulphate of lime, lead, or other objectionable substances, and the powders are put up in truly air-tight packages. Otherwise the deterioration leads to the use of larger quantities of the powder, and often with the result of introducing larger quantities of the alumina compounds into the bread.

Results of Analysis.

The following tables give the results of analysis of the samples, so far as was necessary to classify them and determine their "strength;" that is, the percentage of carbonic-acid gas. The cubic inches of gas are given from one ounce avoirdupois of powder, at a temperature of 60° F., and barometer at thirty inches.

I. Cream-of-Tartar Powders.—In this class are placed all powders giving re-actions for tartaric acid and potash, and free from the phosphates, alumina, and any considerable quantity of soluble sulphates. Ammonia was sometimes present, whether as sesqui-carbonate or bitartrate was not determined. Free tartaric acid was found in one case. Its presence has no effect on the wholesomeness of the powder, nor has the small amount of ammonia in any case found. The writer's experience is that the powders free from ammonia compounds yield just as light biscuits, etc., as the others. As regards purity of materials, there seems little choice between the higher grades of these powders.

II. Acid-Phosphate-of-Lime Powders.—The first two of these were packed in tightly corked glass bottles, and contained enough starchy material to keep them from deteriorating in these bottles. The bread preparation consisted of two separate powders, each in a paper package. One was bicarbonate of soda; the other, acid phosphate of lime mixed with starch. The strength was determined on a mixture of the two in the proportions directed on the packages. The wheat-powder was put up in tin boxes, without starch or other filling. One sample was in excellent order; the other, much caked.

III. Alum and Phosphate Powders.—This class embraces powders showing ammonia, soluble sulphates, alumina, and phosphates, when tested as already described. Inasmuch as some of these powders showed considerable alumina in the simple water solution, a more detailed examination of them is recommended, for the reasons already given. The actual presence of acid phosphate of lime, or of any other acid phosphate, was not proven; but all contained some phosphate, and have therefore been classed as indicated, although probably in every case they were made with acid phosphate of lime. As already mentioned, the low grade of several is perhaps from deterioration, due to the presence of the acid phosphate in packages not sufficiently air-tight. Acid phosphate will not keep well when mixed with bicarbonate of soda, except in well-corked bottles. Tin cases are not tight enough. Many of these powders contained sulphate of lime, chemically equivalent to *terra alba*. This was, perhaps, in no case added as an adulterant, but was a part of the acid phosphate of lime used; the latter not having been separated from the sulphate of lime formed in its

manufacture. The presence of this sulphate of lime must be regarded as objectionable. None of these powders are as strong as they might be made, and most of them are very deficient in strength. Apart from questions of healthfulness, there can be no economy in buying some of these powders.

IV. Alum-Powders. — Here are classed the powders showing the same re-actions as the preceding class, but free from phosphates. All appeared to be ammonia alum-powders, but re-actions for potash and tartaric acid were not wanting among them. Only one of them begins to come up to the strength which a "straight" burnt ammonia alum-powder might have.

V. Unclassed Powders. — The composition of these is such as to present their coming under any of the previous heads.

I. Cream-of-Tartar Powders.

Analyst's Number.	Brand.	Carbonic-Acid Gas, Per Cent.	Cubic Inches Carbonic-Acid Gas, Per Ounce.	Remarks.
4	The Best.....	11.60	107.3	
5	Sea Foam.....	10.86	100.5	{ Yields a little ammonia and soluble sulphate.
23	Sterling.....	11.70	108.2	Yields ammonia re-actions.
29	Health.....	6.96	64.4	{ Final re-action of aqueous solution strongly alkaline.
50	Health.....	7.23	67.1	
39	None Such.....	12.64	116.9	
40	Cleveland's.....	13.27	122.7	Received in June.
43	Cleveland's.....	13.82	127.8	Received in November.
41	Royal.....	13.56	125.43	{ Yields ammonia re-actions. Received in May.
42	Royal.....	13.06	120.8	{ Yields ammonia re-actions. Received in November.
45	Price's "Cream".....	11.95	110.5	{ Received in May. Contains free tartaric acid.
53	Price's "Cream".....	12.20	112.9	Received in December.
	Average (8 brands).....	11.60		{ Excluding 29 and 50, average is 12.43 per cent of carbonic acid.

II. Acid-Phosphate-of-Lime Powders.

Analyst's Number.	Brand.	Carbonic-Acid Gas, Per Cent.	Cubic Inches Carbonic-Acid Gas, Per Ounce.	Remarks.
46	Horsford's Phosphatic.....	14.95	138.3	{ Received in August. In eight-ounce glass bottle.
54	Horsford's Phosphatic.....	14.01	129.6	{ In retail dealer's stock one year. A little gas escaped on opening the four-ounce bottle.
47	Rumford's Yeast-Powder....	13.51	125.0	{ Received in May. In eight-ounce glass bottle.
43	Rumford's Yeast-Powder....	13.89	128.5	{ Received in August. In eight-ounce glass bottle.
49	Horsford's Bread Preparation	15.39	142.4	{ Received in August. Bicarbonate of soda and acid phosphate put up in separate papers. The acid phosphate was not quite free from soluble sulphates
21	Wheat.....	15.62	144.5	In tin box; in good order.
52	Wheat.....	5.83	53.9	In tin box; much caked.

III. Alum and Phosphate Powders.

Analyst's Number.	Brand.	Carbonic-Acid Gas, Per Cent.	Cubic Inches Carbonic-Acid Gas, Per Ounce.	Remarks.
1	Patasco.....	8.32	77.0	
2	Washington.....	8.81	82.5	Received in May.
27	Washington.....	9.97	92.2	Received in November.
3	Davis' O. K.....	8.99	83.2	
7	McDowell's G. & J.....	9.70	89.7	
9	Lincoln.....	9.73	90.0	
10	Kenton.....	7.01	64.8	{ Received in October. Another sample, received in May, gave 3.81 per cent.
11	State.....	6.70	62.0	Received in October.
15	State.....	8.42	77.9	Received in May.
13	On Top.....	9.17	84.8	
16	Perfection.....	5.09	47.1	{ In paste-board box with tin ends.
19	Silver Star.....	9.51	88.0	
24	Our Own.....	10.47	96.8	
35	White Star.....	10.09	93.3	
28	Somerville.....	8.39	77.6	
30	Grape.....	10.02	92.7	
31	Sovereign.....	8.96	82.9	
32	A. & P. (Atlantic & Pacific)..	8.97	83.0	
33	Higgins.....	6.63	61.3	Received in September.
51	Higgins.....	11.30	104.5	Received in December.
34	Windsor.....	8.77	81.1	
37	Brooks & McGeorge.....	10.16	94.0	
38	Henkel's.....	10.24	94.7	
	Average (20 brands).....	8.97		

IV. Alum Powders.

Analyst's Number.	Brand.	Carbonic-Acid Gas, Per Cent.	Cubic Inches Carbonic-Acid Gas, Per Ounce.	Remarks.
8	Miles' "Prize".....	9.63	89.1	{ Shows potash re-actions, and reduces silver abundantly.
20	Four Ace.....	10.31	95.4	
26	Feather Weight.....	9.63	89.1	
36	One Spoon.....	16.77	155.1	{ Two other samples gave respectively 15.35 and 16.73 per cent.

NOTE. — Since the rapidity with which a baking-powder gives off carbonic acid gas in the cold varies with the ingredients used, it was deemed worth while to test some powders as follows: Forty-five grains (three grams) of each was mixed, with as little shaking as possible, with one-sixth ounce (five cubic centimetres) of water, and the volume of gas evolved in five minutes was measured.

Cleveland's yielded 49.6 per cent of its carbonic acid.
 Royal " " 45.6
 Horsford's " " 68.8
 A "straight" " " " "
 burnt alum " " 6.3

V. Unclassed Powders.

Analyst's Number.	Brand.	Carbonic-Acid Gas, Per Cent.	Calc. Intra-Car- bonic-Acid Gas Per Ounce.	Remarks.
6	Silver Prize.....	8.14	75.3	Shows potash and ammonia re-actions, and reduces silver abundantly. Contains a soluble alumina compound. Shows ammonia re-actions; contains much soluble sulphate and some free tartaric acid.
22	Orange.....	8.00	74.0	
18	Our Best.....	6.15	56.9	

Professor Cornwall says, in conclusion, "Our investigations show, that, while especially the higher grades of cream-of-tartar and acid-phosphate-of-lime powders are maintained at a quite uniform standard of excellence, the State is flooded, also, with many baking-powders of very poor quality,—cheap goods, poorly made. Of the thirty-nine brands examined, twenty-five contain alum or its equivalent, in the shape of some soluble alumina compound; eight are cream-of-tartar powders, with small quantities of other ingredients in several cases; four are acid-phosphate-of-lime powders; two belong properly under none of the above classes.

"With one exception, the powders containing alum all fall below the average strength of the cream-of-tartar powders, and in the majority of cases they fall much below the better grades of the cream-of-tartar powders."

"In the cream-of-tartar and the acid-phosphate-of-lime powders, no indications of substances likely to be injurious to health, in the quantities used, have been found.

"More evidence against the use of alum in baking-powders might have been presented, but it would have been of a similar nature to that which has already been given. In the writer's opinion, the presence of alum in baking-powders is objectionable, since, under certain conditions, it may exert an injurious effect on the digestion. The effects may not be very marked in the case of any individual consumer; but that they can be induced to a greater or less extent, seems to be well established.

"There appears to be ample ground for requiring that the makers of baking-powders should publish the ingredients used in their powders, in order that the consumer, who may justly have doubts of the desirability of using certain kinds, may be protected. At present the only guaranty of an undoubtedly wholesome and efficient article appears to be the name of the brand.

"Moreover, since it is quite possible to put up the baking-powders in such a way as to preserve their strength very thoroughly, and since it is evident that many makers fail in this respect, it would not seem unreasonable to require that baking-powders should not be sold unless they will yield a certain percentage of carbonic-acid gas. The bad effects of the 'heavy food' prepared with some of the baking-powders among our samples must certainly be felt by those who use them, and who are yet too ignorant to know where the trouble lies. It is for this class especially that nearly all legislation relating to securing good food and drugs is enacted.

"Since it is evident that some of the alum-powders are so prepared as to increase the extent of any injurious effect, owing to the mixture of ingredients whose combination cannot be justified on any grounds, it is recommended that a special and more thorough examination of such be made, with a view to preventing their manufacture."

THE MINERAL WEALTH OF BRITISH COLUMBIA.

In 1877, Mr. George M. Dawson prepared, in connection with the Canadian Government Surveys for the Canadian Pacific Railway, a general note on the mines and minerals of economic value of British Columbia, which was published in the "Railway Survey Report" for that year, and was afterwards reprinted, with some

additions, in the "Report of Progress of the Geological Survey for 1877-78." Since that time great changes have occurred in respect to the aspects of mining in British Columbia, and important additions have been made to our knowledge of its mineral resources and geology. In view of these, and the increasing interest now manifested in the development of the natural resources of the province, and the numerous inquiries constantly received on that subject, it appeared to be desirable to place the available information respecting its mineral wealth in the hands of the public in a summarized form. With this object in view, Dr. Dawson began the revision of the publication first referred to, but soon found, that, in order to obtain a reasonably satisfactory result, it would be necessary practically to rewrite the whole. The work has in consequence assumed proportions larger than were at first contemplated, and now appears as "The Mineral Wealth of British Columbia" (Montreal, Dawson Brothers), with an annotated list of localities of minerals of economic value.

The object of this publication is twofold. It is, in the first place, intended to serve in some measure as an exponent of the mineral wealth of the province to which it refers; to provide an answer of a general kind to the inquiries now so frequently made on this subject; and to collect for this purpose, in a convenient form, brief summaries of the facts contained in the several official reports on the geological features of the province, with specific references to the pages in which they are treated of at greater length. In the second place, it is designed to place in the hands of the "prospector" or miner a convenient synopsis of facts, with a list of localities likely to be of interest to him. In the endeavor to carry out this second purpose, it has been considered advisable to add notes on such general principles, and to advance such suggestions, as, from the study of the geological features of the province (dating from 1874), appear to be of importance, and likely to be of service at the present time in guiding the search for or exploitation of its metalliferous deposits. In further pursuance of this object, some facts resulting from late practice and investigations in other mining regions are alluded to, and their application to the problems of development in British Columbia is briefly noted.

While the important developments now in progress in the province appear to call for the present publication, it is to be anticipated that within a short time any thing that can now be said regarding vein-mining will be relegated to a position of merely historical interest.

The province of British Columbia, with an area of 390,344 square miles, includes a length of over 800 miles of the Cordillera belt of the West Coast,—a region of mountains and of geological disturbance, which, in this part of its extent, between the Pacific Ocean and the elevated western margin of the Great Plains, has a breadth averaging about 400 miles. This great mountain region extends north-westward and south-eastward, and constitutes the effective cause which has produced the similar trend of the Pacific coast between the same parallels of latitude. It represents the northern continuation of the most important metalliferous area of the United States, essentially repeating its main orographic features, though presenting also some notable differences of a general kind, as well as many local peculiarities.

The Cordillera belt, in British Columbia, may be described as comprising four great mountain systems or principal axes of uplift and geological disturbance, which are, in the main, nearly parallel to each other and to the coast,—the Rocky, the Gold, the Coast, and the Vancouver ranges.

The Rocky Mountain range proper is the farthest inland, and has an average breadth, in its southern part, of about sixty miles, but is decreased near the Peace River to forty miles or less, and apparently loses its importance and regularity locally where cut through by the Liard, though recovering both still farther to the north-westward. Near the 49th parallel, several summits occur in this range which exceed 10,000 feet in height; but northward few attain this elevation till the headquarters of the Bow River are reached. About the sources of the North Saskatchewan and Athabasca, the range appears to culminate, and Mounts Brown and Murchison occur, with reputed heights of 16,000 and 13,500 feet respectively. Near the Peace, few summits exceed 6,000 feet, so far as known. Though more or less extensive snow-fields occur in many

places, true glaciers are found only about the heads of the Bow, North Saskatchewan, and Athabasca. Some of the valleys penetrating this range on the east are lightly timbered or in part prairie-like in character, but as a rule the mountains are thickly wooded wherever sufficient soil exists for the support of trees; and, owing to the greater rainfall on the western slopes of the range, the forests are there often very dense.

Crystalline schists and granite are scarcely known in any part of the Rocky Mountains between the 49th and 60th parallels, the ranges being built up chiefly of a great series of paleozoic rocks, extending from the Cambrian to the carboniferous, with a total thickness of more than 28,000 feet in the Bow River region. There are also, however, more or less isolated basins of rocks of cretaceous age, which rocks were evidently at one time continuous with those of the same age in the eastern foot-hills and Great Plains. In these basins, beds of bituminous coal and of anthracite are found. Deposits of copper ores and of galena are so far the most important metalliferous minerals discovered in association with the older rocks of this mountain system.

The south-western side of the Rocky Mountain range is defined by a very remarkable, straight, and wide valley, which can be traced uninterruptedly from the 49th parallel to the head waters of the Peace, — a distance of 700 miles or more. This valley is occupied by the upper portions of several of the largest rivers, including the Kootanie, Columbia, Fraser, Parsnip, and Finlay. Gold-placers have been found and worked at a number of points along this valley, and important discoveries of various ores are now being made in its vicinity near the Upper Columbia and Upper Kootanie. It is naturally adapted to become a main line of communication between the southern and northern portions of the province, near its eastern boundary.

The next mountain system to the south-west of the Rocky Mountains is referred to under the general name of the "Gold Range," though really a complex and somewhat irregular mountainous belt, which includes several more or less distinct and partly overlapping ranges. The Purcell, Selkirk, and Columbia¹ ranges constitute its southern part, while to the north it is represented by the Cariboo Mountains, and still farther northward — after an important interruption — by the Omenica and Cassiar Mountains. These mountains are, generally speaking, less rugged in detail than the Rocky Mountains, including extensive areas of high, rolling plateau country, and supporting in their southern and more massive portion numerous glaciers and wide snow-fields. The highest summit so far actually measured is Mount Donald, on the line of the Canadian Pacific Railway, 10,645 feet. The forests of the Purcell, Selkirk, and Columbia ranges are dense and tangled; and these mountains are much more difficult to traverse, and even less perfectly explored, than the corresponding portion of the Rocky Mountains. Granites and crystalline schists of great age are abundant in the Gold Range, together with great masses of paleozoic rocks, respecting the structural relations of which very little is as yet known.

The Gold Range, as a whole, doubtless constitutes the most important metalliferous belt of the province. The richest gold-fields are closely related to it, and discoveries of metalliferous lodes are reported in abundance from all parts of it which have been explored. The deposits already made known are very varied in character, including highly argentiferous galenas and other silver-ores and auriferous quartz veins.

Between the Gold and Coast Ranges lies a region, which, for purposes of description, has been named the "Interior Plateau of British Columbia," having an average width of one hundred miles and a mean elevation of about 3,500 feet. Its height, on the whole, increases to the south; while northward it falls gradually toward the group of large lakes and the low country about the head waters of the Peace. This has, over a considerable part of its area, been covered by widespread flows of basalt and other volcanic rocks in the later tertiary period. It is now traversed in various directions by a system of deep, trough-like valleys of erosion, generally occupied by streams and rivers. Water standing at an elevation of three thousand feet above the present sea-level would flood most of these, and would divide its surface into a number of

islands, while a large tract of country about the 53d and 54th parallels of latitude would be completely submerged. In some places the plateau is pretty level and uniform, but many portions of it attain an elevation much exceeding the mean above stated; and it is usually only when broadly viewed, and in contrast with its bounding mountain ranges, that its character as a plateau is apparent. Its main area is practically closed to the north, about latitude 50° 30', by the ends of several intercalated mountain ranges, in which many of the summits attain a height of 8,000 feet. Nearly coincident with the 49th parallel is a second transverse mountainous zone, formed in the same way, the only orographically important gap in which is that found in the vicinity of the Okanagan River. The southern portion of the Interior Plateau includes much open country, constitutes the best grazing region of British Columbia, and affords, besides, some good agricultural land. To the north, with increasing moisture, it becomes generally forested, but embraces large areas which are suitable for eventual agricultural occupation.

The tertiary rocks of the Interior Plateau hold in many places beds of lignite or of coal. Where not concealed by the later rocks, the formations preponderantly represented belong to the paleozoic age. These include very notable developments of materials originally volcanic in origin. The geological structure is scarcely less complex than that of the mountain regions, and much yet remains to be done toward its elucidation. The Interior Plateau also presents some important granitic areas, and, particularly toward its south-western border, limited basins of cretaceous rocks. As a metalliferous region, it is destined to take high rank, particularly, it is believed, in respect to the precious metals, though its ores are too varied in character to admit of description in a few words. Placer deposits of gold have been worked in a number of widely separated localities, and platinum is abundant in the Similkameen region.

The Cascade Range of Oregon and Washington is largely composed of erupted volcanic materials, to which its characteristic features are due, though these materials rest upon a basis of older rocks. Its course is north and south, and it is definitely terminated in the vicinity of the international boundary. Near the mouth of the Fraser River its place is taken by a new mountain system, geographically and geologically distinct, in the composition of which volcanic ejectamenta play no prominent part. This forms the third member of the Cordillera in British Columbia, and, under the name of the "Coast Ranges," pursues a direct north-westward course for over 900 miles, forming throughout this distance the bordering mountain-zone of the continent. The Coast Ranges have an average width of about one hundred miles, and consist of numerous constituent ridges and minor mountain-axes with varied trends, frequently separated by deep parallel and transverse valleys. The average altitude of the higher summits is between 6,000 and 7,000 feet, while some exceed 9,000 feet. Glaciers are of frequent occurrence, and large in size, in the northern portions of the Coast Ranges. The mountains are, as a rule, densely forested and extremely rugged, the flora of their seaward slopes being that characteristic of the West Coast, and co-ordinated with its great humidity, while on north-eastern flanks the forest resembles that of the inland ranges.

Geologically the Coast Ranges owe the greater part of their elevation to a period later than the cretaceous, of which formation patches are found in them at great heights. The rocks consist chiefly of gray granites and granitoid materials, with which are associated gneisses and other crystalline schists, as well as paleozoic rocks resembling some of those of the Interior Plateau. In association principally with the last-named rocks, gold-placers occur locally. Copper and iron ores are frequently found, and rich silver ores have been discovered.

The name "Vancouver Range" may be applied as a general one to the fourth great mountain-axis, which, in a partially submerged condition, appears in Vancouver and in the Queen Charlotte Islands, and is continued southward nearly to the Columbia River by the Olympian Mountains of Washington Territory. The islands of the Alaskan archipelago have, on the map, the appearance of constituting a northern continuation of the same mountain system; but they may be more appropriately regarded, from an oro-

¹ The name "Gold Range" is often specially applied to that here spoken of as the Columbia Range.

graphic point of view, as forming a partially submerged lateral expansion of the Coast Ranges. The highest mountain of Vancouver Island—Victoria Peak—reaches an elevation of 7,484 feet, while there is a considerable mountainous area in the centre of the island which surpasses 2,000 feet in average altitude. Several summits in the Queen Charlotte Islands exceed 4,000 feet.

The Vancouver Range, while still to a considerable extent formed of crystalline rocks like those of the Coast Ranges, is principally composed of stratified rocks of paleozoic and triassic age, and is flanked in places, both on Vancouver and on Queen Charlotte Islands, by cretaceous rocks, which are here important because of their coal-bearing character. The areas underlain by these rocks are in general comparatively low, and hilly rather than mountainous; while a large tract of level land, based upon the tertiary formation, occurs in the north-east part of the Queen Charlotte Islands. Gold-placers have been worked in several places on Vancouver Island, but few ever attained much importance. Iron, copper, and lead ores and gold-bearing quartz are also known to occur in connection with this mountain-axis; but up to the present time the coal deposits have proved to be vastly its most important feature.¹

The general correspondence of that portion of the Cordillera belt included in British Columbia with that of the western portion of the United States, in some parts of which mining operations of the first importance have been in progress now for many years, has already been alluded to. No feature of the geology of the continent is more remarkable than the general persistence of certain zones of similar rocks in a direction coincident with that of the Cordillera itself,—a circumstance in part due to the original similarity in conditions of deposition of sediments, and in part to their equal participation, at a later date, in changes produced by like metamorphic agencies. The similarity thus observed, in a series of geological zones parallel to the general direction of the Pacific coast, is here more striking than the continuity of the constituent orographic uplifts of the mountain-belt, and contrasts very markedly with the diversity of rock-formations found to occur where this belt is crossed at right angles. While metalliferous deposits individually are inconstant, and even the best defined lodes can be followed, in the vast majority of cases, for but a moderate distance, their character is found to depend fundamentally upon that of the enclosing or adjacent rocks, in which, under the required local dynamic and other agencies, these deposits are found to recur with nearly identical features. It is not intended here to discuss the resemblances and differences of the various rock series met with in the corresponding region in the Western States with those of British Columbia; but it may be mentioned that the metalliferous districts of the province may with advantage be compared by the miner with those which have already been more fully developed in each corresponding portion of the Cordillera region to the south, and that from such rational comparisons useful indications may be derived in the present early stages of the development of the mines of British Columbia.

The Rocky Mountains proper, as previously defined, can scarcely be traced southward, with identical characters, farther than the main head waters of the Missouri, beyond which the eastern ranges of the Cordillera become more lax and irregular. The Gold Range may, however, be followed farther in a southerly direction, being continued by the Cabinet, Cour D'Alaine, and Bitter Root Mountains for about 300 miles. The Interior Plateau of British Columbia represents the Great Basin of Utah and Nevada, and the Great Plains of the Columbia, and combines to some extent the features of both; though differing markedly from the first in the fact that it is not here self-contained as to its drainage, and from the second in the diminished importance of its tertiary lava-flood. It has already been stated that the Coast Ranges of British Columbia are not continued to the south of the international boundary. They resemble the Sierra Nevada more closely than they do the Cascade

Mountains of Washington Territory and Oregon, and hold a similar relation to the interior basin with that held by the Sierra. While, however, the Sierra owes its elevation to a time immediately antedating the cretaceous, the main uplift of the Coast Ranges of British Columbia occurred at or after the close of that period. The Vancouver Range, again, dating from the same period with the last, is not traceable south of the Columbia River, beyond which, in Oregon and California, the Pacific is bordered by a range of coast-hills, which, from a geological point of view, are of very recent origin.

In California the principal auriferous territory coincides with the run of a certain belt of slaty and schistose rocks, which occurs on the western flank of the Sierra Nevada; these rocks being referred, by their contained fossils, to the triassic and cretaceous divisions of the geological scale. In British Columbia, while rocks of triassic age are largely developed, and in some cases with characters identical with those of the Californian gold-bearing rocks, no such persistent belt of these rocks is found in connection with the Coast Ranges, where (from what has just been said of the resemblance of the two mountain systems) it might, from analogy, have been sought for. While local occurrences of rich gold-placers are known, in association with slates probably of triassic age, on both sides of the Coast Ranges, the main auriferous territory in the province is found to align itself on the Gold Range; and the original deposits of gold, from which the placers have been supplied, are already known to exist in different series of rocks widely separated in age, and ranging all the way from the triassic to the Cambrian. While, therefore, there is no single well-developed gold-producing region, as in California, the area and mass of the rocks throughout which deposits of gold may be hopefully looked for are here greatly increased. The circumstances would also warrant the belief that the mode of occurrence of gold in its original matrix might differ from that found to the south, and in particular that this might be more varied. So far as investigation has gone, such a belief appears to be well grounded, and it would seem that to a very considerable extent the natural laws of this mining-field must be worked out independently.

In correspondence with the absence of the tertiary coast-hills of California, in which, under peculiar conditions of mineralization, the cinnabar ores of that State are developed, it is observable that in British Columbia no really important deposits of mercury have yet been discovered. It is by no means improbable that mercury ores may yet be developed in the province; but, if so, it cannot be in any continuation of the Californian cinnabar belt, and the conditions of such deposits may be expected to prove unlike.

Another and very important point of diversity is found as respects the cretaceous rocks of the southern and northern coast regions. In California and Oregon the mineral fuels which have been found and worked are lignites of tertiary age and of an inferior value. Similar fuels are known on the coast of British Columbia: but the rocks of the cretaceous here assume the rôle of a coal-bearing series, and yield coals of excellent quality, which more than hold their own in competition with all other fuels employed on the Pacific.

Still another noteworthy circumstance of difference, and one which is applicable to practically the entire area of the province when it is contrasted as a whole with the Pacific States, is that which has been produced by the general spread and movement of ice over this region during the glacial period. The changes thus effected in the distribution of surface materials, and directions of drainage, have most important bearings on the question of placer mining. They have also encumbered the surface of considerable tracts with "drift" deposits, which, while tending to produce a more fertile soil, largely conceal the indications to which the prospector generally trusts in more southern latitudes. At the same time, a great part of the oxidized upper portions of metalliferous veins, together with the atmospherically decayed country-rock associated with these, has been removed; thus often obscuring the outcrops of such veins, which would otherwise be well marked, and in the treatment of certain classes of ores rendering it necessary to begin work from the first with machinery and processes which in some other regions are only required after considerable depths have been attained.

¹ In connection with the foregoing outline of the ruling physical and geological features of the province, it should be stated, that while these features are moderately well known in the southern portion of the province, and as far northward as the 56th degree of latitude, and while in connection with the Yukon expedition some accurate information has been obtained for the extensive northern portion, there yet remains a large region, chiefly included between the 56th and 58th parallels, which, though touched upon here and there by the gold-miner, is yet almost unknown geographically and geologically.

These conditions, brought about by action during the glacial period, are among those which, in Dr. Dawson's opinion, have most tended heretofore to retard the development of metalliferous mining in British Columbia. Other circumstances which have operated in the same direction are, the densely wooded character of a great part of the country; the fact that the rivers are suited for navigation only in detached reaches; the remoteness from the coast of the richest and best-known placer-mining districts; and the cost of labor, supplies, and machinery, which may be regarded as in part concomitants, in part direct results, of these. Owing to the inaccessibility of the country, it has, till very recently, been prospected and exploited by the placer-miner alone, who has been deterred by no difficulty from reaching the most remote spots in which rumor, or reasoning of his own, lead him to expect the existence of the precious metal. Little knowledge or effort was expended in the search for metalliferous veins. Many such deposits supposed to be of value, were, it is true, located, and time and money which could ill be spared often uselessly spent upon them, leading only to discouragement. Even where the indications met with were altogether favorable, the original discoverer generally found that the capital and knowledge required for their development were not at his command, and it was difficult to interest those capable of dealing with such mines in a region which they could not easily visit and become familiar with at first-hand. With regard at least to the whole southern portion of the province, however, all this is now happily changed.

While speaking of causes which have hitherto stood in the way of vein-mining, it must also be mentioned that not the least important of these has been, and still is, the fictitious or exaggerated value too frequently placed upon entirely undeveloped discoveries. While it is manifestly right that the discoverer should be properly remunerated, it should be remembered that a mere surface showing, however promising, generally requires the expenditure of a large sum before its true value can even be ascertained, and that till thus developed it is unreasonable to expect a large payment for any mining claim.

In preceding paragraphs particular attention has been drawn to certain notable differences between the better-known and more fully developed regions of the southern part of the Pacific slope and those of the province of British Columbia, chiefly as a note of caution against the rash assumption of complete uniformity in conditions too often made without due investigation. The salient fact of the general identity of the structural features of the Cordillera region south and north, however, remain, and is such, that from this alone, even without taking into consideration the numerous and important discoveries already made, we should be justified in predicting an eventual great development of metalliferous mining in the province. It has already been stated that British Columbia includes a length of over 800 miles of the most important metalliferous belt of the continent; and, adding to this the northern extension of the same belt beyond the 60th parallel, we find that within the boundaries of Canada its entire length is between 1,200 and 1,300 miles. This, as has elsewhere been noted, is almost precisely equal to the whole length of the same region included by the United States from the southern line of Canada to the northern boundary of Mexico; and Dr. Dawson, after having enjoyed exceptional opportunities of investigation, feels no hesitation in recording his belief that the northern moiety of the Cordillera will ultimately prove to be susceptible of a development corresponding in importance to that which has already been attained in the southern.

British Columbia first rose from the position of a fur country to the rank of a colony, on the discovery of gold upon the Lower Fraser in 1858. Its subsequent history for a number of years is substantially that of the sudden rise and subsequent slow decline in importance of placer gold-mining. Coal-mining has, however, concurrently advanced, slowly but steadily, till it has obtained its present pre-eminent position. Such historical facts as appear to be important to the appreciation of these industries are touched on later in connection with them. With respect to vein-mining proper, we have as yet to chronicle merely the first steps; but in the southern part of the province the completion of the Canadian Pacific Railway has at length afforded the necessary impetus in this direction, and it is very gratifying to find, as an immediate

consequence, that this part of the country is rapidly beginning to prove its valuable character, and to justify the confidence which those best able to form an opinion on the subject have always felt and frequently expressed. Every thing which has been ascertained of the geological character of the province as a whole, tends to the belief, that, so soon as similar means of travel and transport shall be extended to what are still more inaccessible districts, these also will be discovered to be equally rich in minerals, particularly in the precious metals, gold and silver. In the southern district, for which information is most complete, praiseworthy efforts are now in progress, at a number of widely separated localities, toward the exploitation of ores, which, in many cases, have already been proved to be of an exceptionally valuable character. Here, at least, there is every reason to believe that we are on the point of witnessing the inauguration of an era of mining activity of the most important kind.

AMONG THE PUBLISHERS.

The *Journal of Morphology* for June, being the first number of Vol. III. (Boston, Ginn), contains the following articles, besides eight lithographic plates: "The Actinaria of the Bahamas," by Playfair McMurrich; "Contributions to the Osteology of the North American Passeres," "Notes on the Anatomy of Speotyto," by R. W. Shufeldt; "Variation of the Spinal Nerves in the Caudal Region of the Domestic Pigeon," by James I. Peck. The second number, that for August, will contain "The Mechanical Origin of the Structures of the Hard Parts of the Mammalia," by E. D. Cope; "The Embryology of Blatta and Doryphora," by William M. Wheeler; besides numerous cuts and seven lithographic plates. For the third number, the "Embryology of Linnbricus," by E. B. Wilson, is promised, and a paper by William Patten, dealing with the general embryology, including the segmental sense-organs, of arthropods. This number will probably be issued in October. A fourth number will probably be given with this volume, but its contents cannot be definitely stated. The subscription price is nine dollars for the volume, whether including three numbers or four.

—We have just received the first part of Vol. I. of the new "Century Dictionary," published by The Century Company, New York. This number appears in a unique and attractive binding, embracing the letters from A to Appet, and will be a welcome addition to the library. The work will be completed in six volumes of four parts each.

LETTERS TO THE EDITOR.

Fog.

A GREAT deal of discussion has recently taken place on the properties of fog and its causes. One writer attributes the celebrated London fog to the cooling of the air by radiation from hill-sides near the city, which air, flowing down, envelops the city. It has also been suggested that a cool northerly wind on the west side of a storm flows into the saturated air on the south side, and condenses fog. Again, over Newfoundland it is thought that a saturated current flows from the southward to cooler waters, often having ice floating in them, and thus produces fog. The objection to the first theory is, that the cause assigned could not develop a fog 500 or 1,000 feet thick. In the second case it seems plain that the cool north wind is always dry, and would quickly render the air unsaturated. In the last case, while the cause assigned might produce a fog just at sea-level, yet this would hardly be extensive enough, and it is probable that a calm is essential in fog-production.

Fog, it is admitted, is simply cloud composed of water-dust or solid minute spheres of water from $\frac{7}{10000}$ to $\frac{1}{10000}$ of an inch in diameter. It is supposed by some that a dust-particle must be a nucleus for each sphere. When we consider the billions of such spheres in a cubic inch of fog, we may well halt, and demand that the moisture in a few cubic feet of fog be evaporated, and the trillions of dust-particles massed under a microscope, where they certainly ought to be visible. The laboratory experiments advanced to prove this theory seem entirely inadequate, when we consider the extreme improbability of such an hypothesis.

It would seem as though our views as to the condensation of these fog-particles, and consequent liberation of latent heat, must be very much modified. We are told that moist air, say, at 99 per cent relative humidity, has different properties from saturated air at 100 per cent. The first, by theory, has a diminution in temperature of one degree in 188 feet vertical height; while the second, at 80°, has a diminution of one degree in 500 feet. It does not seem possible for such enormous differences to exist in two masses of moist air so near alike. It is supposed that dry air has a capacity for molecules of vapor without change of volume, and dependent entirely upon the temperature. For example: a cubic foot of dry air weighs, at sea-level, 566 grams; the same saturated will weigh 571 grams at 56°, and 576 grams at 77°. If it weighs 571 grams at 77°, we say it is half saturated. It would seem as though the arrangement of the molecules must be precisely the same in the latter case as when the humidity is 99.9 per cent or 100 per cent, except that they are in a condition, in the moister air, to unite more readily. It would be a great stretch of the imagination to consider that there is any marked difference in the condition of the molecules at 99.9 per cent and at 100 per cent.

Suppose we cool saturated air very slightly: all the molecules cannot remain as vapor, but some of them coalesce, as do globules of mercury when they touch each other. It would seem probable that if, as many admit, rain is simply the coalescing of a very great number of minute cloud-particles, we may extend the same action a step farther back, and consider that the original molecules also mechanically coalesce without setting free any latent heat. If this be so, there certainly is not needed any dust-particle as a nucleus for the mingling. We have now our air still saturated with vapor, and at the same time full of, say, double molecules of vapor. If we cool still more, the double molecules add others to themselves, and we finally have our fog or fog-particles floating in saturated air.

It has been thought that these particles (spheres) are kept in suspension very much as dust is, but this hypothesis seems untenable. Others have considered that each sphere is electrified, and repels every other sphere; and there is some color to this from the fact that a vivid flash of lightning overhead is often followed by a heavy and sudden downpour of rain. It seems probable that we

can extend this hypothesis still farther back, and regard each molecule as electrified. May not the coalescing of these molecules be dependent upon their electrical state as much as or even more than upon their cooling? The principal point to be borne in mind is, however, that the formation of fog and cloud is a purely mechanical process, unaccompanied by the evolution of heat. A striking proof of this was observed during an ascent of Greylock, in Massachusetts, on Dec. 15, 1883. At the summit the wind was blowing a whole gale, and the temperature was -7°, with the air saturated but perfectly clear. In a few minutes there were just barely perceptible little white particles upon the overcoat. In a very short time the aggregation of particles, absolutely invisible to the eye, had become completely white. On the trees the particles had massed nearly an inch thick. Another proof of this mechanical aggregation is found in making observations with Regnault's dew-point apparatus. It would be supposed that as the dew-point is reached there would be a uniform deposit of molecules upon the plate; but this is not the case, as there are spaces between the dew-particles. The effect is most noticeable when hoar-frost is beautifully deposited in very marked lumps, at temperatures below freezing.

The cause of fog seems briefly as follows: 1. It is essential that there be no wind. I do not mean that the wind does not blow the fog after it is formed, but there must be little or none while it is forming. 2. The sky must be clear. We often notice a cloudless sky after a fog is dissipated. On weather-maps, "fog" is entered as "fair," for, though not a particle of sky is visible, yet it is almost a certainty that the sky is clear. 3. The air must be saturated, or nearly so. It is very surprising how rarely the last condition occurs at inland stations. A relative humidity of 95 per cent has been noted in the air, in which rain is falling, and had been falling continuously for seventeen hours. This condition almost always can occur only to the south, south-east, or north-east of a storm. At nightfall, whenever these conditions combine, there is a rapid radiation from the earth to the sky, which speedily supersaturates the overlying air; and, after that, radiation from the upper surface of the fog continues the process, and extends the fog upward until the action ceases with the rising of the sun.

H. A. HAZEN.

Washington, D.C., May 24.

Publications received at Editor's Office, May 13-25.

BACIGALUPI, E. G. Immunity through Leucocytines. Tr. by R. F. Rafal, M.D. New York, J. H. Vail & Co. 170 p.

CENTURY Dictionary, The. Vol. I. Part I. A-Appet. New York, The Century Co. 272 p. f. \$2.50

CHURCH, I. P. Mechanics of Engineering. New York, Wiley. 822 p. 35¢. 85¢.

COUSINS, R. H. A Theoretical and Practical Treatise on the Strength of Beams and Columns. London and New York, E. & F. N. Spon. 170 p. 12¢. \$2.50

GRAEVES, J. Statistics for Beginners. London and New York, Macmillan. 179 p. 16¢. 90 cents.

GUIMPS, R. de. Pestalozzi: his Aim and Work. Tr. by Margaret C. Crombie. Syracuse, N.Y., C. W. Bardeen. 290 p. 12¢. \$6.00.

HAMBLETON, G. W. The Cure of Consumption. London, Balliere. 30 p. 12¢.

HAYES, P. S. Electricity and the Methods of its Employment in removing Superfluous Hair and other Facial Blemishes. Chicago, W. T. Keener. 128 p. 16¢.

JOHNSON, Laura Winthrop. Eight Hundred Miles in an Ambulance. Philadelphia, Lippincott. 131 p. 16¢. 75 cents.

PRÉVOST, L'Abbé. The Story of Manon Lescaut and of the Chevalier des Grieux. Tr. by Arthur W. Gunther. Chicago, New York, and San Francisco, Belford, Clarke, & Co. 310 p. 12¢.

ST. JOHN, E. A Postal Dictionary. New York, Evening Post. 91 p. 24¢. 15 cents.

STARR, L. Hygiene of the Nursery. 2d ed. Philadelphia, Blakiston. 280 p. 12¢. \$1.

STOWELL, T. B. Syllabus of Lectures in Anatomy and Physiology. 3d ed. Syracuse, N.Y., C. W. Bardeen. 120 p. 12¢.

TEACHER'S Outlook, The, a Monthly Magazine devoted to General Literature, Science, Health, Industrial and National Affairs. Vol. I. No. 1. Des Moines, Ia., Teacher's Publ. Co. 22 p. 8¢.

THOMAS, C. Aids to the Study of the Maya Codices. Washington, Government. 115 p. 4¢.

U. S. GEOLOGICAL SURVEY. Topographical Maps of Portions of Oregon, Virginia, West Virginia, New Mexico, North Carolina, Nevada, Massachusetts, Texas, Maryland, Alabama, Missouri, and Kansas. Washington, Government, 1889. 28 maps, 43 by 53.5 cm.

WALWORTH, J. H. A Splendid Egotist. Chicago, New

York, and San Francisco, Belford, Clarke, & Co. 240 p. 12¢.

WHITTIER, J. G. The Tent on the Beach. (Riverside Literature Series, No. 41.) Boston and New York, Houghton, Mifflin, & Co. 72 p. 16¢. 15 cents s.

Correspondence solicited with parties seeking publishers for scientific books.

N. D. C. HODGES,
Publisher of Science,
47 Lafayette Place,
New York.

Old and Rare Books.

One Million Magazines. Back numbers, vols. and sets—old and new, Foreign and American. CATALOGUE UPON APPLICATION.

A. S. CLARK,
34 Park Row, New York City.

BACK NUMBERS and complete sets of leading Magazines. Rates low. AM. MAG. EXCHANGE, Scholharie, N.Y.

H. WILLIAMS,
 Dealer in Old Magazines, Reviews, &c. Scientific periodicals a specialty. 39 Macdougal St., N.Y.

THE LAST NUMBER EDITED BY ALLEN THORNDIKE RICE.

North American Review, JUNE, 1889,

WITH A PORTRAIT OF MR. RICE.

CONTENTS.

Wealth..... Andrew Carnegie
 What is the Destiny of Canada? Erastus Wiman
 Unhappy Marriages in Fiction... Andrew Lang
 How to Restore American Shipping, Nelson Dingley, Jr.
 Last Days of the Steam Engine, R. H. Thurston
 The Inevitable Surrender of Orthodoxy, The Rev. Minot J. Savage
 How a Census is Taken..... Carroll D. Wright
 The Mischievous Ice-Fletcher, Dr. William A. Hammond
 Religious Value of Enthusiasm, William Booth, of the Salvation Army
 Sir Arthur Sullivan and Piracy, Alexander P. Browne
 Why Am I a Quaker?..... J. A. R.

NOTES AND COMMENTS.

Iconoclasm Necessary to Progress, Percy Douglas
 Illustrious Seconds..... Gertrude F. Atherton
 The Politics Nearest Home..... Sylvester Baxter
 America for the Americans..... M. A. Westcott
 An Ignominious Destiny..... William Matthews
 A Plea for the Dialect Story, William E. Baldwin

All Newsdealers. Fifty Cents.

GUARANTY INVESTMENT COMPANY

CAPITAL \$250,000.

Hon. ALBERT H. HORTON (Chief Justice, Kansas Supreme Court), Topeka, Kan., Pres't.

7% Guaranteed Farm Mortgages 7%

The Company calls the special attention of Investors to the following points :

- I. All loans guaranteed and interest payable semi-annually at the Importers' & Traders' National Bank, New York.
- II. Unusual fulness of information, not only about the security itself, but about the general development of the section where the farm is located.
- III. An examination each year of the general business of the Company and the Mortgages themselves by a COMMITTEE OF INVESTORS sent for the purpose.
- IV. Many hundred Mortgages taken and NOT A SINGLE FORECLOSURE.
- V. Exhibitions in New York at frequent intervals, of Kansas and Nebraska Farm Products. The Exhibition at the American Institute in the fall of 1888, received the *HIGHEST AWARD* of superiority.
- VI. Monthly Bulletins giving full information about all Mortgages offered for sale.

Address for Monthly Bulletin and Investors' Committee Report for 1888,

HENRY A. RILEY, General Eastern Manager, 191 Broadway, N.Y.

ESTABLISHED 1859.

H. A. DREW,
Commercial Printer,
5 Clinton Place, near Broadway,
New York.

Wedding Orders, Souvenirs, Invitations, Orders of Dance, etc., etc., done in the latest and most elaborate styles, at reasonable prices.
All Favors promptly attended to.

Specialties in Silks.

We shall put on sale, this week, one line of Black Faille Francaise, 20 inches wide, at 75 cents per yard; and a very large purchase of Plain Colored Gros Grains, in over 30 desirable shades, at 75 cents per yard.

These goods are of exceptional value, and calculated to give excellent satisfaction.

Samples sent on request.

JAMES McCREERY & CO.
BROADWAY AND ELEVENTH ST.,
NEW YORK CITY.

THE
American Bell Telephone
COMPANY.
95 MILK ST., BOSTON, MASS.

This Company owns the Letters Patent granted to Alexander Graham Bell, March 7th, 1876, No. 174,465, and January 30, 1877, No. 186,787.

The Transmission of Speech by all known forms of **ELECTRIC SPEAKING TELEPHONES** infringes the right secured to this Company by the above patents, and renders each individual user of telephones, not furnished by it or its licensees, responsible for such unlawful use, and all the consequences thereof and liable to suit therefor.

Original, Simple, Natural, Suggestive, Comprehensive, Educational and helpful entirely apart from the memory phase of the subject. JOURNAL of EDUCATION

Memory SHEDD'S NATURAL METHOD, PRACTICAL, SCIENTIFIC.
Entirely different from any other memory method. Thoroughly taught by correspondence.
ENDORSED BY LEADING EDUCATORS.
DESCRIPTIVE PAMPHLET FREE.
MEMORY SCHOOL, 4 W. 14th STREET NEW YORK CITY.

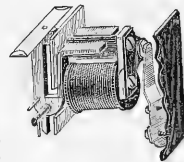

A
★
DROP
IN THE
PRICE
★ OF

GRAVITY
DROP
ANNUNCIATORS.

DON'T FORGET THE
DUST-PROOF BELLS.

HAZAZER & STANLEY,
32 Frankfort Street, N. Y.

IMPROVING
THE
MEMORY PICK

and facilitating the acquirement of knowledge by lectures and correspondence. Classes forming. "MEMORY and its Doctors," from Simonides to "Loisette," mailed for 10 cents.
DR. PICK, 24 Union Square, N. Y. City.

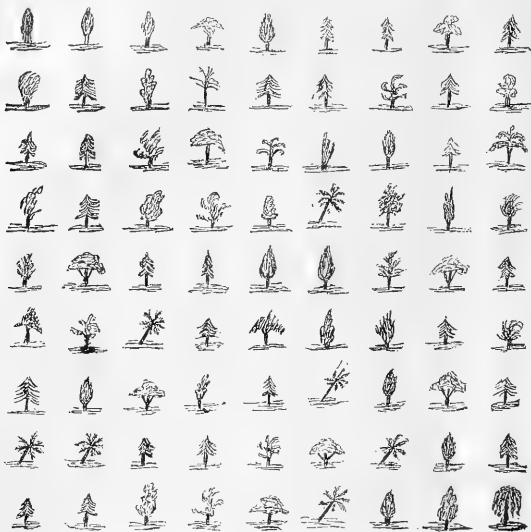

Can any reader of Science solve the following puzzle?

A man having 81 trees to cut, arranged as above, cuts nine each day for nine days without cutting on any one day more than one tree from any line, vertical, horizontal, or diagonal.

Any one who will have the following blank filled out by a responsible Newsdealer, and mailed to us, will be allowed a three months' subscription to *Science*.

N. D. C. HODGES,
47 LAFAYETTE PLACE, NEW YORK.

1889.

To the *News Company.*

You may add to my regular order five copies of SCIENCE each week (returnable).

SCIENCE CLUBBING RATES.

	10% DISCOUNT.		Year's Subscription.	With Science.	With The Swiss Cross.
We will allow the above discount to any subscriber to <i>Science</i> or <i>The Swiss Cross</i> who will send us an order for periodicals exceeding \$10, counting each at its full price.					
Agricultural Science.....	\$ 2.50	\$ 2.25	\$ 4.50	\$ 4.05	\$ 4.50
American Agriculturist.....	1.50	1.35	2.50	2.25	2.50
American Analyst.....	1.00	.90	2.25	2.02	2.25
American Architect and Building News.					
Imperial edition.....	10.00	12.80	11.00		
Gelatine.....	7.00	9.80	8.00		
Regular.....	6.00	8.80	7.00		
American Garden.....	1.00	1.25	2.25		
American Journal of Philology.....	3.00	3.25	4.25		
American Machinist.....	2.50	3.30	3.50		
American Naturalist.....	4.00	5.30	5.00		
Andover Review.....	4.00	6.80	5.00		
Atlantic.....	4.00	6.80	5.00		
Babyhood.....	1.50	4.30	2.50		
Babylond.....	1.50	3.75	1.75		
Bradstreet's.....	2.00	4.80	6.00		
Brain.....	3.50	6.30	4.50		
Building (weekly).....	6.00	9.80	7.00		
Carpentry and Building.....	1.00	4.25	2.25		
Century Magazine.....	3.00	5.80	4.00		
Chautauquan, The.....	1.50	4.30	2.50		
Christian Union, The.....	3.00	5.80	4.00		
Christian Worker, Illustrated.....	2.50	5.30	3.50		
Cosmopolitan, The.....	2.00	4.80	3.00		
Critic.....	3.00	5.80	4.00		
Eclectic Magazine.....	5.00	7.80	6.00		
Edinburgh Review.....	4.00	6.80	5.00		
Electrical World.....	3.00	5.80	4.00		
Electrician and Electrical Engineer.....	3.00	5.80	4.00		
Electrical Review.....	3.00	5.80	4.00		
Engineering and Mining Journal.....	4.00	6.80	5.00		
English Illustrated Magazine.....	3.00	5.80	4.00		
Forest and Stream.....	4.00	6.80	5.00		
Forum, The.....	5.00	7.80	6.00		
Godley's Lady's Book.....	2.00	4.80	3.00		
Harper's Bazar.....	4.00	6.80	5.00		
Harper's Magazine.....	4.00	6.80	5.00		
Harper's Weekly.....	4.00	6.80	5.00		
Harper's Young People.....	2.00	4.80	3.00		
Health and Home.....	4.00	6.80	5.00		
Herald of Health.....	1.00	4.25	2.25		
Illustrated London News (Amer. reprint).....	4.00	6.80	5.00		
Independent.....	3.00	5.80	4.00		
Inter Ocean, The.....	1.00	4.25	2.25		
Iron Age (weekly).....	4.00	7.30	5.50		
Journal of Philology (Eng.).....	2.50	5.30	3.50		
Journal of Speculative Philosophy (begins with Jan. No.).....	3.00	5.80	4.00		
Judge.....	4.00	6.80	5.00		
L'Art.....	12.00	14.80	13.00		
Life.....	5.00	7.80	6.00		
Lippincott's Magazine.....	4.00	6.80	5.00		
Littell's Living Age.....	8.00	10.80	9.00		
Little Men and Women.....	1.00	4.25	2.25		
London Quarterly.....	4.00	6.80	5.00		
Macmillan's Magazine.....	3.00	5.80	4.00		
Magazine of American History.....	5.00	7.80	6.00		
Medical and Surgical Journal.....	5.00	7.80	6.00		
Mechanical Engineer.....	2.00	4.80	3.00		
Metal Worker.....	1.00	4.25	2.25		
Microscope, The.....	1.00	4.25	2.25		
Nature.....	6.00	8.80	7.00		
New Princeton Review.....	3.00	5.80	4.00		
North American Review.....	5.00	7.80	6.00		
Outing.....	3.00	5.80	4.00		
Overland Monthly.....	4.00	6.80	5.00		
Pansy.....	1.00	4.25	2.25		
Political Science Quarterly.....	3.00	5.80	4.00		
Popular Science Monthly.....	5.00	7.80	6.00		
Popular Science News.....	1.00	4.25	2.25		
Portfolio, The.....	7.50	10.30	8.50		
Practitioner.....	3.50	6.30	4.50		
Public Opinion.....	3.00	5.80	4.00		
Puck.....	5.00	7.80	6.00		
Puck (German).....	5.00	7.80	6.00		
Queries.....	1.00	4.25	2.25		
Rural New-Yorker.....	2.00	4.80	3.00		
St. Nicholas.....	3.00	5.80	4.00		
School Journal.....	2.50	5.30	3.50		
Scientific American.....	3.00	5.80	4.00		
Supplement.....	5.00	7.80	6.00		
Architect and Builders' edition.....	2.50	5.30	3.50		
Scientist's Magazine.....	3.00	5.80	4.00		
Southern Cultivator.....	1.50	4.25	2.25		
Springfield Republican (weekly).....	1.00	4.25	2.25		
Sunday School Times.....	2.00	4.80	3.00		
Teachers' Institute.....	1.25	4.25	2.25		
Texas Sittings.....	4.00	6.80	5.00		
Trained Nurse.....	1.50	4.30	2.50		
Treasure-Trove.....	1.00	4.25	2.25		
Truth Seeker, The.....	3.00	5.80	4.00		
Wide Awake.....	1.00	4.25	2.25		
Young Folks' Journal.....	1.00	4.25	2.25		

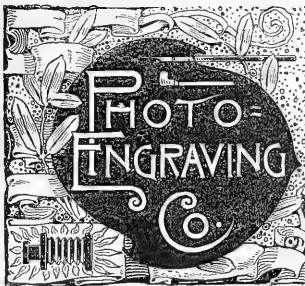

JOHN HASTINGS = Pres't.
A=R=HART = Gen-Manager
JOS=TRIPP = V-Pres't.

ENGRAVING FOR ALL ILLUSTRATIVE AND ADVERTISING PURPOSES

BRANCH AT 72 B. CHESTNUT ST. PHILADELPHIA, PA.

67-71 PARK PLACE, NEW YORK.

N. D. C. HODGES,
47 Lafayette Place,
New York.

C. & C. ELECTRIC MOTOR COMPANY.

Electric Motors
FOR
Arc and Incandescent Cir-
cuits, Most Economi-
cal Motor on the
Market.
Regulation Perfect.
Motors Designed for all
Power Purposes.

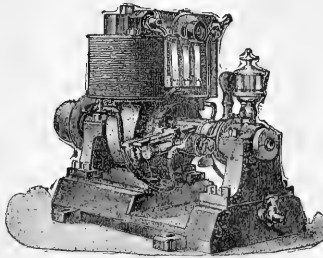

OFFICE and MANUFACTORY:
402 and 404 Greenwich Street, New
York City.
New England Office, 19 Pearl St., Boston.
Philadelphia Office, 301 Arch St.
Western Office, 139-141 Adams Street,
Chicago.
Southern Office, 25 Carondelet Street,
New Orleans.

16 PAGES. **THREE** 16 PAGES.

Hundred Thousand subscribers for *The Family Journal* and *Ladies' Companion* wanted. It is the most interesting and instructive paper ever issued. Subscribers will receive during the coming twelve

MONTHS

novels written by American Authors, complete in each three numbers. The story of popular works of fiction will be retold by a novel reader, the most interesting and unique feature ever introduced in any publication, giving the substance of popular and standard books by famous writers in a space easily read by the busiest people. We have engaged

FOR

this work a widely known and popular writer. Comments on Current Events, Fashions, New and Original Ideas and Designs for Ladies' Fancy Work and Household Decoration, Letters from Correspondents and their Answers. Also collages and summaries of the United States will be treated one each month in an illustrated article, showing the particular advantage of each, cost of attendance, etc. Invaluable to parents having sons or daughters whom they desire should receive the advantages of a higher education than the ordinary school affords. Articles on Painting and Drawing, giving home instruction by a well-known artist. A trial subscription of this elegant paper will be sent to any address, three months, for

TEN CENTS.

Liberal pay for literary work adapted to our columns, and for new and original drawings, designs and ideas on any subject which we can use. Premium List the most complete in the world. We offer inducements to our readers and agents approached by no other publishing house. The celebrated Gilbert Our Waist Linings, which we send post paid to any one sending us two yearly subscribers at 10 cents each is also worth 16 cents. 12¢ sent to any agent for one year, 50 cents; six months, 25 cents, and three months trial subscription for only 10 cents.

TRY IT! TRY IT! TRY IT!
and you will become a permanent reader. Address:
John L. Douglass, Publisher,
322 Broadway, N. Y.

A NEW MAGAZINE—THE SWISS
Devoted to spreading a love of
nature among the people. Edited
by HARRY H. KALMAN, President of the Agnesis Association,
and succeeding *St. Nicholas* as the official magazine of that body. 31.50 a year. Sample copy 10 cents, or 25 cents for trial subscription for one month.
N. D. C. HODGES, PUBLISHER,
Mention this paper. 47 Lafayette Place, New York.

Wants.

A YOUNG MAN can have lucrative employment, not only a fixed salary, but according to his work accomplished in travelling for SCIENCE. A personal interview invited.
N. D. C. HODGES,
47 Lafayette Place, New York.

MECHANICIAN.—An optician and maker of instruments of precision of experience would be glad of a position where his skill would be valued in connection with some higher educational institution. Address G. J., care of SCIENCE, 47 Lafayette Place, New York.

Scientific Apparatus.

J. GRUNOW,

621 Sixth Avenue, New York.
Established 1852.

MAKER OF

Microscope Stands,
Oil Immersion Objectives and Abbe Condensers for Bacterial and Histological work, of Objectives, Camera Lucida and other accessory apparatus.

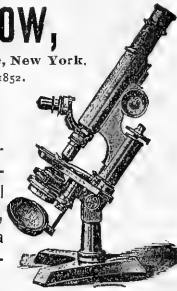

IMPROVED OIL LIGHT MAGIC LANTERNS.

Also Lime and Electric Light Apparatus, and mechanical, plain, and fine colored views.
J. B. COLT & CO., Manufacturers,
No. 16 BEEKMAN STREET, NEW YORK.

MAGIC LANTERNS Stereopticons and the Best Views for Public, Church, Home, and SCIENTIFIC Exhibitions. Best apparatus, new views. Largest stock. Reduced prices. 24 Years' Practical Experience. Illus. Catalogue Free.
GEO. H. PIERCE,
136 S. Eleventh St., Philadelphia, Pa.

ELECTRICAL TESTING BUREAU,

Johns Hopkins University, Baltimore, Md.
Resistance Coils and Boxes Compared.
Am meters and Volt meters calibrated.
Condensers standardized.
Primary and Secondary Batteries Tested.
Efficiency of Dynamos and Motors Determined.
Insulation of Cables and Wires Tested.
Etc., Etc.
Circulars describing Methods Used, Prices, Etc., sent on Application.
Address as above.

MORRIS EARLE & CO.
SUCCESSORS TO
R. & J. BECK,

1016 Chestnut Street, Phila.

Microscopes and all Accessories and Apparatus. Photographic and Photo-Micrographic Apparatus and Outfits.

Spectacles, Eye Glasses, Opera and Marine Glasses, etc.

Illustrated Price List mailed free to any address. Mention SCIENCE in corresponding with us.



Amateur Outfits in great variety, from \$3.00 upward. Send for Catalogue or call and examine. More than 40 years established in this line of business.

Schools.

CONNECTICUT, NEW HAVEN,
MRS. CADY'S SCHOOL FOR YOUNG LADIES.
Prepares for Smith and Wellesley, and admits to Vassar by Certificate. Circulars. Early application necessary.

NEW JERSEY, PLAINFIELD.
THE CHESTNUTS.—Parents with daughters to educate, or orphan girls with companion, may find a comfortable home, with school instruction by applying to Miss E. E. Kenyon.

A TEMPORARY BINDER
for *Science* is now ready, and will be mailed postpaid on receipt of price.



Half Morocco - 75 cents.
This binder is strong, durable and elegant, has gilt side-title, and allows the opening of the pages perfectly flat. Any number can be taken out or replaced without disturbing the others, and the papers are not mutilated for subsequent permanent binding. Filed in this binder, *Science* is always convenient for reference.

N. D. C. HODGES,
47 Lafayette Place, N. Y.

Readers of Science
Corresponding with or visiting Advertisers, will confer a great favor by mentioning this paper.

Sprague Electric Railway and Motor Company.

Lightest Weight Consistent with
Highest Efficiency.
SIMPLE IN CONSTRUCTION.
Not Liable to get out of Order.

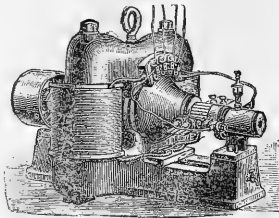

Bearings Self Oiling,
NON-SPARKING IN OPERATION.
Commutator Wear Reduced
to a Minimum.

16 and 18 BROAD STREET, NEW YORK.

The Mutual Life Insurance Company OF NEW YORK.

RICHARD A. McCURDY, PRESIDENT.

ASSETS - - - \$126,082,153 56

The Largest and best Life Insurance Company in the World.
The New Business of the Mutual Life Insurance Company in 1888
Exceeded \$103,000,000.
Its Business shows the Greatest Comparative Gain made by
any Company during the past year including

A gain in assets of.....	\$ 7,275,301 68
A gain in income of.....	3,096,010 06
A gain in new premiums of.....	2,333,406 00
A gain in surplus of.....	1,645,622 11
A gain in new business of.....	33,756,792 85
A gain of risks in force.....	54,496,251 85

The Mutual Life Insurance Company

Has Paid to Policy-holders since its Organization \$272,481,839 82.

PARIS EXPOSITION.

The **Cheque Bank** issues Cheques, either singly or put up in books, for the special use of **VISITORS** to the **PARIS EXPOSITION**, who can cash the same at upwards of **seventy** Banking Houses, situated in different parts of Paris, **without charge**.
Visitors' mail matter can be addressed to them, Care of the Societe Generale, 4 Place de l'Opera, opposite the Grand Hotel, where English is spoken.
Every Cheque that is issued by the **Cheque Bank** is **EQUAL TO CASH**, as Bank Notes are, for the Bank's Capital, Guarantee Fund and Customers' Balances are **invested in British Government Securities**, or held in Cash in the **Bank of England**, and can be cashed in every town in Europe without charge.
For Handbook containing list of **2,500** Banking Houses who cash the cheques, *free of charge*, apply to

CHEQUE BANK, Limited,
Capital, £100,000. Guarantee Fund, £27,000.
Trustees, The Right Honorable John Bright, M.P.,
The Right Honorable Earl Beauchamp.
NO. 2 WALL STREET, NEW YORK.

Visitors to Europe and Paris Exposition should carry a book containing **Cheque Bank Cheques**, which are absolutely safe and cheaper than Letters of Credit, and much more convenient; are payable on presentation *without charge* at 2,500 Banking Houses and 250 of the principal Hotels in Europe.

**KIMBALL'S
STRAIGHT CUT
CIGARETTES.**
Unsurpassed in quality.
Used by people of refined taste.
Highest award at Brussels, 1883.
The finest smoking mixtures are of our manufacture.
Fifteen First-Prize Medals.
WM. S. KIMBALL & CO.,
Rochester, N.Y.

**SOMETHING NEW
THE
ADJUSTABLE BRUSH.**

Patent Pocket Can. No waste.

**THE
STRONGEST
GLUE
IN THE WORLD.
2 GOLD MEDALS
RUSSIA & GENEVA
Stouffer & Thos.**

Used by thousands of first-class mechanics and by such manufacturers as Pullman Palace Car Co., Mason & Hamlin Organ and Piano Co., &c., &c.
Repairs Everything.
Its success has brought a lot of imitators copying us in every way possible. Remember that **THE ONLY GENUINE Le Page's Liquid Glue** is manufactured solely by the **RUSSIA CEMENT CO. GLOUCESTER, MASS.**
Send 10c. and dealers' card who doesn't keep it in stock, for sample.

**ESTERBROOK'S
STEEL PENS.**
OF SUPERIOR AND STANDARD QUALITY.
Leading Nos.: 048, 14, 130, 135, 239, 333
For Sale by all Stationers.
THE ESTERBROOK STEEL PEN CO.,
Works : Camden, N. J. 26 John St., New York.

**THE GREAT AMERICAN
TEA
COMPANY**

**GOOD NEWS
TO LADIES.**
Greatest inducements ever offered. Now's your time to get up orders for our celebrated **Teas and Coffees**, and secure a beautiful Gold Band or Moss Rose China Tea Set, Dinner Set, Gold Band Moss Rose Toilet Set, Watch, Brass Lamp, or Webster's Dictionary. For full particulars address **THE GREAT AMERICAN TEA CO.,**
P. O. Box 259. 31 and 33 Vesey St., New York.

**FOOD
ADULTERATION**
And its Detection. With photomicrographic plates and a bibliographical appendix. By J. P. Battershall, 328 pages, 8vo, cloth. Price, \$3.50. Circulars and Catalogues on application.
E. & F. N. SPON,
12 Cortlandt St., New York.

Readers of Science
Corresponding with or visiting Advertisers
will confer a great favor by mentioning the paper.

What Scott's Emulsion Has Done!

Over 25 Pounds Gain in Ten Weeks.
Experience of a Prominent Citizen.

THE CALIFORNIA SOCIETY FOR THE
SUPPRESSION OF VICE.
SAN FRANCISCO, July 7th, 1886.

I took a severe cold upon my chest and lungs and did not give it proper attention; it developed into bronchitis, and in the fall of the same year I was threatened with consumption. Physicians ordered me to a more congenial climate, and I came to San Francisco. Soon after my arrival I commenced taking **Scott's Emulsion of Cod Liver Oil with Hypophosphites** regularly three times a day. In ten weeks my avoirdupois went from 155 to 180 pounds and over; the cough meantime ceased. **C. R. BENNETT.**

SOLD BY ALL DRUGGISTS.

SCIENCE

[Entered at the Post-Office of New York, N.Y., as Second-Class Matter.]

A WEEKLY NEWSPAPER OF ALL THE ARTS AND SCIENCES.

SEVENTH YEAR.
VOL. XIII. No. 331.

NEW YORK, JUNE 7, 1889.

SINGLE COPIES, TEN CENTS.
\$3.50 PER YEAR, IN ADVANCE.

SOME NEW ELECTRIC MOTORS.

FOR several years past the C. & C. Electric Motor Company have devoted their entire energies to the manufacture of small motors, having built thirty-six hundred motors of $\frac{1}{2}$ horse-power, and over five hundred $\frac{1}{4}$ and $\frac{3}{8}$ horse-power motors. While this company have built motors as large as 5 horse-power, they have not until recently, when the new shops were completed, undertaken to sup-

The machines present a few peculiarities. The field-magnet cores are drop-forged, are circular in shape, and are concentric with the shaft, being oblong in cross-section, and of a width equal to the axial length of iron in the armature. These cores, when bolted to the base of the pole-pieces, completely surround the armature, which is of the drum type, and in its general proportions resembles a Gramme ring, in which the radial depth is increased until the annular ring reaches the shaft, thus forming a drum ar-

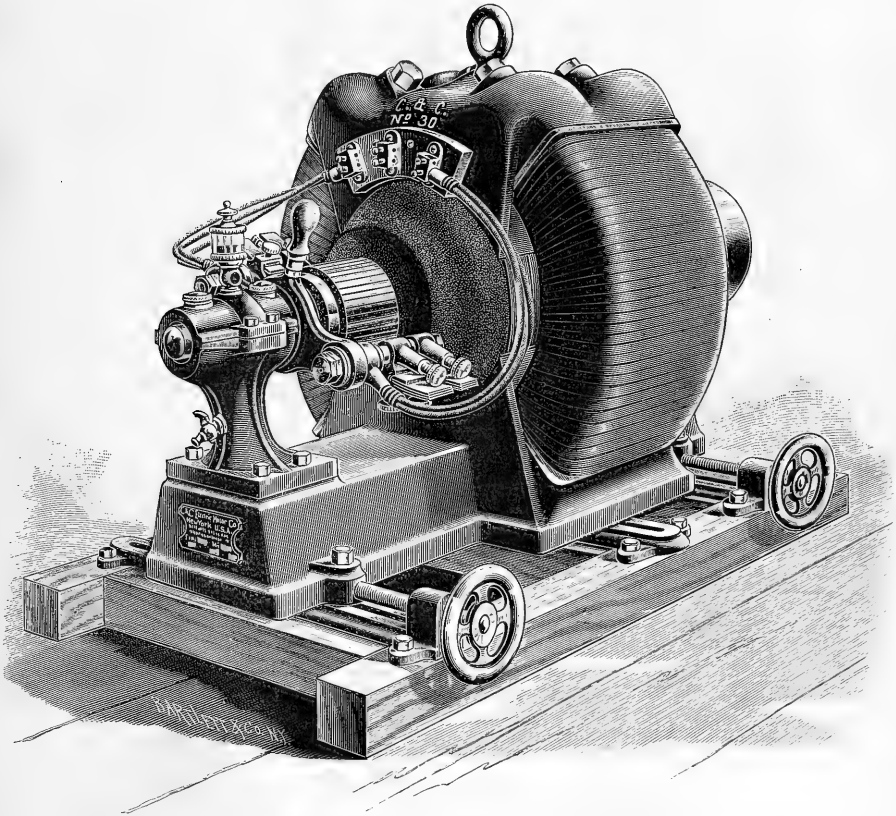

FIG. 1.—FIFTEEN-HORSE-POWER C. & C. MOTOR.

ply those of larger power, their old shops having been fully occupied with orders for small motors.

We recently described their new factory, and since the company moved in, Mr. Lemuel William Serrell has designed for them motors as large as 25 horse-power. The design of these larger motors is shown in the accompanying cuts. Fig. 1 is of a 15 horse-power, Fig. 2 of a 3 horse-power, motor.

mature of large diameter. This form requires little wire, and the air-space resistance between the pole-piece and the armature is reduced to a minimum.

The windings are calculated by dealing with the magnetic circuit as if it were an electric circuit, following Ohm's law: magnetic potential taking the place of volts; and lines of force, current; and the resistance of the iron when below saturation to the flow of

lines of force, the resistance of a wire to an electric current. The shortest possible length for the magnetic circuit is obtained by giving a circular form to the machine. The result shows that the machines have come out very close to their estimated power, the

claimed to have considerable advantage over most slow-running fans. Two of these fans have been successfully employed to ventilate a hall 100 feet square, being placed opposite each other, and both used as exhausts. Another method employed is to place one

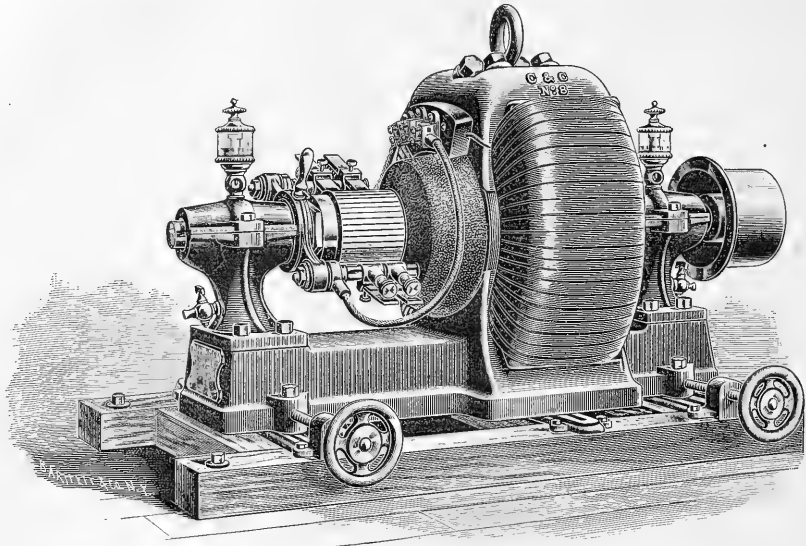

FIG. 2.—THREE-HORSE-POWER C. & C. MOTOR.

actual number of volts developed being 109 against 110 in a 3-horse power motor. It has been aimed at to eliminate Foucault's currents and undue heating.

of these fans at either end of a hall, one running as an exhaust, and the other forcing air in.

WATER-FILTRATION.

PROBABLY at no time has the condition of the water-supply of our cities and towns received more attention than at present, and perhaps no one thing has conduced to this state of affairs more than the discovery that certain salts contained in the earth act as renovators of all so-called "spring" waters, purging them, so to speak, of the foul matters held both in solution and in suspension.

Up to the time of this discovery, it was thought that the earth acted merely as a filter or strainer on a large scale, and that each grain or atom of earth acted its part toward opposing or arresting impurities in the passing water; in other words, that only mechanical straining or filtering took place, and nothing more.

Multitudes of filters have been made and put in operation in all ages and countries with the expectation of seeing the water emerge from them as pure and sparkling as from a good "spring," and the greatest surprise has been manifested at the failure to secure the same results when apparently every condition was supplied. The question remains, "Was every condition supplied?" Modern science answers, "No."

The peculiar action of the above salts upon the portion of impurities said to be held in solution is well illustrated by the effects produced by dissolving soap in a water of great (so called) hardness. The white flakes that almost instantly appear are composed not alone of dissolved soap (for soft water would not show such individualized flakes), but a mixture of soap and some substance hitherto held in undisturbed solution in the water, but now withdrawn from that condition and floating about in mechanical suspension.

It will be plain that if this soap-treated water was now poured into the earth at one point, and made to emerge at another some distance off, it would be found purged of not alone the soap it contained, but also of the modicum of foreign matter held in its embrace, and which went to make up the quality of hardness spoken of.

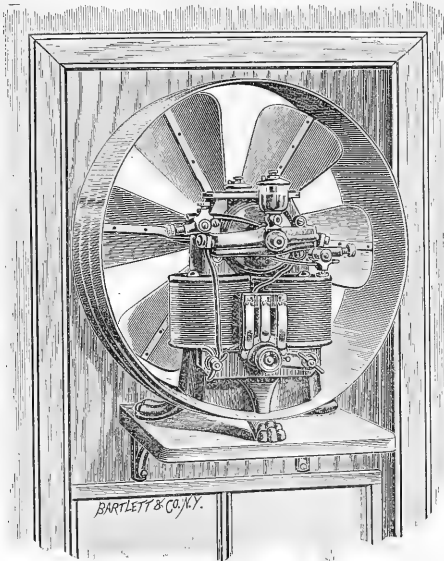

FIG. 3.—THE C. & C. COMPANY'S MOTOR AND EXHAUST FAN.

Another application of this motor is to the driving of ventilating-fans. Fig. 3 shows a $\frac{1}{4}$ -horse-power incandescent motor fan outfit. This apparatus at a speed of one thousand revolutions a minute is

This subject is so little (generally) understood, that it seems necessary to use the above illustration for the benefit of the casual reader, although to the chemist a hundred different applications of the same law will suggest themselves. Indeed, it is noted here for the purpose of calling more emphatic attention to the simple fact that water may contain impurities in absolute (chemical) solution, and that such impurities, by the addition of another substance, may be rendered tangible, and capable of withdrawal from the water by purely mechanical means.

Equally clear and understood should be the statement that water may contain impurities in a state of fine (mechanical) suspension,—so fine that they would flow wherever water would flow,—and these, by the addition of another substance to the water, be made to flock together into groups, a thousand or two into one (as clouds are condensed into drops); and that one, with its fellows, be tangible, and easily removed from the water by purely mechanical means.

It follows, that if the earth contains in abundance this "substance," which has the dual property of disengaging matter held in solution, and rendering the same tangible, and also of curdling together matter held in so fine a state of division as to almost elude the senses into a state of perfect tangibility, we at once get at the secret of how nature makes the true spring-water, so wonderfully pure and sweet to the taste, as well as brilliantly clear, and inviting to the eye.

What is this substance or substances? Usually some combination of lime, iron, potassium, aluminum, etc., with other bases, such as sulphur or carbon,—all existing naturally in the great mother matrix, the earth.

The almost universal diffusion of the aluminiferous earth (red clay) makes that substance take a more prominent place among the agents above alluded to. Water cannot flow far in any part of the world without encountering in its course the coagulating or curdling effect of this single element. Some of these clays are more heavily charged or freighted with aluminous compounds than others. Waters fouled by such are more quickly subsided. In this fact we have a clew to the explanation of why it is, that, of two different waters showing the same degree of turbidity from clayey impurities, such impurities will subside quickly in one, while in the other they may not subside in months. As proof that the quick subsidence is due to the presence of these salts, we have only to add a minute proportion of such (usually aluminum sulphate) to the other water to produce the same effect. Hence, when water issues from the earth in a very clear and perfect state, we may always be sure that it has encountered somewhere on its travels a body of earth or mineral containing a suitable coagulant, the action of which coagulant upon the water accounts for its wonderful purity aside from and entirely independent of the mere filtering effect of the earth.

It has remained for the present decade to apply the above knowledge to the art of filtration of water, and for the first time produce results equal to nature.

As this industry extends, it will become a common thing to see "spring" water issue from our city faucets, as is already the case in a few American cities, notably Atlanta, Long Branch, and Newport.

The study of this subject furnishes a striking example of Nature's exhibiting, in the humble wayside "spring," the results of her perfect handiwork for the observation and admiration of man throughout all ages and countries, only to deliver up her secret to the pale student of this century of science.

JOHN A. CALDWELL.

THE USE OF SPIRIT AS AN AGENT IN PRIME MOVERS.

A PAPER on the above subject was prepared by A. F. Yarrow at the request of the Council of the London Society of Arts, and was presented May 22. It did not treat of the adoption of spirit or liquid hydrocarbons, such as petroleum, when used as a substitute for coal as fuel, which is an entirely distinct subject, but with the use of volatile liquids in lieu of water, to produce power, when converted by heat from the liquid to the vapor state, in the

same way that power is obtained from the conversion of water into steam.

In the year 1856 this subject attracted much attention in France; and, as a matter of fact, several large steamers were built, and ran between Marseilles and Algiers, in which ether was evaporated in combination with steam for working the propelling machinery. The engines were on the Du Tremblay system. The steam, after having performed work in one cylinder, instead of going at once to the condenser, was used to evaporate ether in a tubular evaporator, by which means a portion of the remaining heat in the steam was absorbed instead of being wasted. The ether vapor so produced was used in another cylinder, the additional power thus obtained being a clear gain. These steamers ran, making regular voyages, for some years, but were ultimately abandoned.

The gain obtained is clearly due to the ether taking a portion of the heat of the exhaust steam, and turning it to useful account, which would otherwise be wasted in raising the temperature of the condensing-water. The ether used evaporates at about 104° F.: it will therefore be seen to what a low temperature the steam or water can be brought down, and still be useful in evaporating the ether.

The system was no doubt economical as regards fuel; but the ether was so difficult to keep, that a renewal of about one gallon per hour was required to make good the leakages. There was also serious risk of explosion on account of these leakages, because the ether, when free, rapidly vaporizes, and when in this state is explosive if mixed with the atmosphere. The difficulties which at that time had to be dealt with are, however, now greatly reduced. Ether, being the spirit used, was far more costly than other volatile liquids which are available now, and consequently any leakage then represented an important item in the working expenses; also, at that period, means for obtaining good workmanship were not available to the engineer, as they are at present, accuracy of workmanship, and soundness of materials, being essential points in dealing with the vapor of these volatile liquids, as it penetrates joints and castings which no steam would. In fact, an amount of care is necessary beyond what is needed in the best steam-engine practice, and sufficiently good work was not available thirty-two years ago.

The success of some small boats lately built in the United States, propelled by spirit vapor, induced Mr. Yarrow to take the matter up with a view to investigate it, and see whether the results would justify his going fully into the matter with a view to its further development. These preliminary investigations look promising.

The apparatus with which the experiments were tried was a small steam-engine of ordinary construction, which actuates a shaft and fly-wheel in the usual way. There was a brake attached to the shaft, with a spring balance and index; also a revolution counter, so that he was enabled to obtain the actual power developed. There was also fitted to this little engine an ordinary indicator, from which to obtain diagrams.

The steam-boiler had no special feature about it: it had simply a combustion-chamber and a straight flue through to the funnel. There was no attempt at economy of fuel, because there was no object in so designing it, all he wished to obtain being the comparative results on a common basis. The heat was obtained by means of ordinary gas, burnt in a large Bunsen burner. Gas was selected as the means of heating because the exact quantity could be accurately regulated and recorded, and with this view there was attached to the inlet pipe a gas-meter. The exhaust from the cylinder passed out, and terminated in a coil of pipe immersed in a tank of running water for the purpose of condensing the steam. From there the condensed steam ran into a hot-well, and passed on to the feed-pump on the engine, and was forced back into the boiler, so that an entire circuit was made. This completes the arrangement for working the engine by steam.

For the corresponding system, when spirit vapor was used, inside the upper part of the boiler was a copper coil, the inlet to which was at the side, and the outlet at the top, whence it passed to the engine. The exhaust pipe from the cylinder was led in this case into a tank where the vapor was condensed, and passed on to the hot-well, thence to the pump, and was forced back into the coil inside the boiler, thus making this circuit complete. Two sets of pipes, condensing-coils, etc., were adopted, so as to avoid, as far as

practicable, any mixture of water and spirit, which would tend to vitiate the experiments.

The heat from the gas-flame is first taken up by the water in the boiler, and is then passed on to the copper coil, and evaporates the spirit; the water only acting as a convenient means of transmitting the heat from the flame to the spirit. By these means it was possible to try steam and spirit vapor under precisely similar circumstances with regard to boiler efficiency.

The experiments consisted of several continuous trials, each of three hours duration, alternately with steam and with spirit vapor. The upshot of these experiments was, that although the amount of gas consumed during the three hours was practically the same, being at the rate of 82 and 83 cubic feet, the power obtained, as tested on the brakes, was, in the case of spirit, nearly twice that recorded in the case of water, the powers being as 4,722 to 2,524.

At equal intervals during these trials, diagrams were taken with an ordinary indicator. The working-out of these diagrams gives a power, in the case of spirit, of 11,975 foot-pounds per minute, and, in the case of water, of 5,199 foot-pounds per minute, which more than confirms the results obtained by the brake.

Touching the class of spirit used for the experiments, Mr. Yarrow mentioned that it was a hydrocarbon distilled from petroleum, having a specific gravity of about .680. The reason this spirit was adopted was because it is low in price, and can be easily procured; and also, being obtained from petroleum, it is of an oily nature. A spirit which is not oily in its character would be deficient in lubricating-power, and therefore not so suitable for working the machinery.

Touching the evaporation of spirit to produce power in actual practice, at present the only application which has been successfully developed is for the propulsion of launches. It is termed the "Zephyr" system. For small sizes, certainly there would seem to be no question, that, where the spirit is obtainable, this system is destined to take the place of steam, not so much on account of the probable increased efficiency, as the general convenience of the arrangement. A launch propelled on this plan, 36 feet long by 6 feet beam, and built of steel, has a total weight, including machinery, of only one ton; while, had it been propelled by steam, the weight would have been considerably greater.

Mr. Yarrow did not venture to assign any reason for the apparent gain in the use of spirit over water, but pointed out, that, in a condensing-engine, the two great losses of heat are due, first, to the waste gases which pass up the funnel, and simply go to raise the temperature of the surrounding air; and, second, to the loss arising through raising the temperature of the condensing-water, which goes to warm the sea.

As regards the first loss, it is self-evident, that, owing to the low temperature at which the spirit evaporates, the products of combustion are available to produce evaporation down to a much lower temperature than in the case of water. As an illustration of the low temperature at which the waste gases pass away in the "Zephyr" launches, when going at full speed, it is quite possible to hold one's hand immediately over the funnel.

The results of these experiments give reasonable ground for believing that this system, in some form, is capable of further and possibly extensive development.

WEST INDIAN HURRICANES.

JUNE is the first of the five months that constitute the hurricane season, and every navigator bound for the tropics should now be on his guard, and watch for the earliest indications of an approaching cyclone, lest it may be of hurricane violence. The "Pilot Chart" last month contained a small chart illustrating the general tracks along which these storms move, together with a diagram explaining the importance of the fact that the tracks recurve in a latitude dependent upon the month. In June, for instance, the point of recurvature is in about latitude 20° to 23° north, and here the entire storm moves in a northerly direction, while in lower latitudes it moves north-westerly, and in higher latitudes north-easterly. Each of the accompanying diagrams is therefore applicable to a slightly different belt of latitude, according to the month, as stated therein. There may be an occasional exception, but a navigator can at first only be guided by the general rule.

A careful study of these diagrams will, it is thought, enable a navigator to form a clear idea as to the general character of West Indian hurricanes. It should, of course, be understood that no two hurricanes are exactly alike; and a master of a vessel can only be guided by what is known from the experience of others, his own experience, and the indications that he can obtain from the weather, wind, barometer, cloud-movements, etc. It is now generally recognized that the old 8-point rule is not always a safe guide for action; and, although the storm-card based upon it has been published on the "Pilot Chart" up to the present time, efforts have been made to explain the spirally inblowing character of the winds in a cyclone. The old storm-card and the 8-point rule can no longer be recommended, except, perhaps, as a rough-and-ready rule for those who will not take advantage of the progress that has been made since this old rule was established. By looking at any one of these diagrams, for instance, it will be seen that the bearing of the centre is hardly ever exactly eight points to the right of the wind, but is generally considerably more than that, especially in rear of the storm. It will be noticed, also, that the storm is never exactly circular, and that its shape changes as it moves along its track. The limited space on the chart forbids any detailed discussion of the subject; but the following brief *résumé*, prepared for the information and guidance of practical navigators during the present hurricane season, is taken from the June "Pilot Chart":—

The hurricane regions embrace the tropics north of the 10th parallel, the Caribbean Sea, Gulf of Mexico, and a broad belt curving north-westward from about St. Thomas, and following the Gulf Stream toward the Grand Banks of Newfoundland.

The earliest indications are, unusually high barometer, with cool, dry, fresh winds, and very transparent atmosphere; a long, low ocean-swell from the direction of the distant storm; light, feathery plumes of cirrus clouds, radiating from a point on the horizon where a whitish arc indicates the bearing of the centre.

Unmistakable signs of a hurricane are the following: As the cirrus veil spreads overhead, with halos about the sun and moon, the barometer begins to fall, slowly but steadily, and the ocean-swell increases; the air becomes heavy, hot, and moist; dark red and violet tints are seen at dawn and twilight; the heavy cloud-bank of the hurricane soon appears on the horizon, like a distant mountain range; the barometer falls more rapidly, and the wind freshens, with occasional squalls of fine, misty rain.

As to general size and velocity of progression, the storm area is smaller in the tropics than farther north, the cloud-ring averaging about 500 miles in diameter, and the region of stormy winds 300 miles or even less. In low latitudes the entire storm moves westward and north-westward about 17 miles an hour; in middle latitudes, north-westward and northward, moving more slowly as it recurs; and finally north-eastward, with a velocity of translation of 20 or even 30 miles an hour, its area increasing rapidly as it follows the Gulf Stream toward the Grand Banks, and sweeps across the Atlantic toward northern Europe.

One of the most important indications that an approaching storm is of hurricane violence is the marked cyclonic circulation of the wind, lower and upper clouds, etc. This may be easily appreciated by remembering that a cyclone of any great intensity is an ascending spiral whirl, with a rotary motion (in the northern hemisphere) against the hands of a watch, as shown on the diagrams. The surface wind, therefore, blows spirally inward (not circularly, except very near the centre); the next upper current (carrying the low scud and rain clouds), in almost an exact circle about the centre; the next higher current (the high cumulus), in an outward spiral; and so on, up to the highest cirrus clouds, which radiate directly outward. The angle of divergence between the successive currents is almost exactly two points of the compass. Ordinarily, with a surface wind from the north, for instance, the low clouds come from the north also; on the edge of a hurricane, however, they come from north-north-east invariably. In rear of a hurricane, the wind blows still more nearly inward. With a south-east wind, for instance, the centre will bear about west, the low clouds coming from south-south-east (two points to the right of the wind), etc. Great activity of movement of the upper clouds, while the storm is still distant, indicates that the hurricane is of great violence.

Another very important fact (established by Meldrum at Mauritius) may be stated thus: When a hurricane is moving along the equatorial limits of a trade-wind region, there is a belt of intensified trades to windward of its track. Not until the barometer has fallen about six-tenths of an inch is it safe to assume, that, because the trade-wind increases in force and remains steady in

good reason to suspect that a hurricane is approaching, consider the latitude you are in, and the month, with a view to decide the probable direction in which the storm is moving, and when its track is likely to recurve. Early action may thus be taken to avoid its path. When the decided fall of the barometer, freshening rain-squalls, and other unmistakable signs, indicate that the cyclone is close upon you, observe the shifts of wind very carefully, in order to determine whether you are to the right or left of the storm-track. Remember that it is sometimes best to lie to when thus observing the shifts of wind. A fast steamer, for instance, may run into the dangerous semicircle of a slow-moving cyclone, and yet get shifts of wind characteristic of the navigable semicircle. If the freshening gale remain steady in direction, you are on the track of the advancing storm: square away, at all hazards, and run with the wind on the starboard quarter, keeping your compass course as the wind shifts; if obliged to lie to, do so on the port tack. If the wind shift to the right, you are to the right of the storm-track: put the ship on the starboard tack, and make as much headway as possible; if obliged to lie to, do so on the starboard tack. If the wind shift to the left, you are to the left of the storm-track: bring the wind on the starboard quarter, and keep your compass course, if possible; if obliged to lie to, do so on the port tack. Any attempt to cross the storm-track is dangerous; but, if you decide that it must be attempted, crowd sail and keep the wind well on the starboard quarter. In scudding, always keep the wind well on the starboard quarter, in order to run out of the storm. If obliged to lie to, always do so on the coming-up tack, so that the wind will shift aft, and not take you aback. Should you get into the central calm of a tropical cyclone, look out for a terrific squall from a point of the compass almost exactly opposite to that from which the wind was blowing when it fell calm.

So long as the barometer continues to fall, the centre is getting nearer. When it steadies and begins to rise, this marks the nearest point; and here the shifts of wind will be most sudden and violent, and the sea highest and most confused. If, when lying to, the wind begins to shift in the opposite direction to what it did at first, it is evidence that the storm-track is recurring, and your semicircle is changed: immediate action must be taken to suit the new conditions. But if your vessel is making any great headway, it may give you a shift of wind contrary to what you would have if lying to: this must be always borne in mind. Cool weather is characteristic, in extra-tropical regions, of the navigable semicircle, owing to the indraught from the north-westward; warm weather, on the contrary, indicates the dangerous semicircle, where the air is drawn in from the south-eastward.

After encountering a hurricane in the tropics, a northward-bound vessel is very liable to encounter the same storm again in higher latitudes, after it has recurved. The navigator should therefore remember that there is a hurricane off to the westward, and look out for it as he goes north.

There are two cyclone currents to be considered, — a current moving in a circular direction around the centre, caused by the wind; and a current which follows the storm along its track. These vary considerably with different storms, but should always be taken into account when near the coast.

The testimony as to the great value of the use of oil in heavy seas is so conclusive that it is now recognized by every commercial nation. No ship can afford to neglect its use in an emergency, when heavy broken seas threaten to come on board. Once tried, its value will never be disputed. Fifty-four reports have already been received this year from masters of vessels who have used oil with great success: thirteen of these refer to a single storm, the hurricane off Hatteras, April 6-9, and new reports are received almost every day.

ELECTRICAL NEWS.

The Average Efficiency of Incandescent Lamps.

At the meeting of the Institute of Electrical Engineers, held on May 22, Mr. W. H. Peirce read a paper under the title "Relation between the Initial and Average Efficiency of Incandescent Electric Lamps," which gave the results of experiments made by him for the Chicago, Burlington, and Quincy Railroad. Four

The small arrows fly with the wind, and the dotted lines (radiating from the centre) join points having same wind-direction (stated at outer arrow). The ovals are isobars, the barometer falling .20 of an inch from one curve to the next inner one. The shaded area is the region where it is most dangerous for a vessel. The average size of one of these storms in different latitudes can be estimated by means of the scale of miles accompanying each diagram.

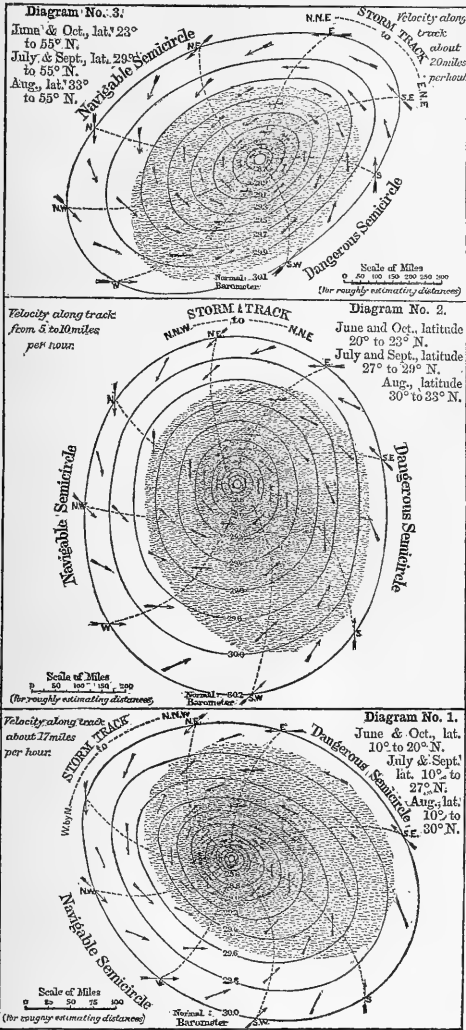

direction, you are on the track of the storm. By attempting too early to cross its track, running free as soon as the wind begins to freshen, you are liable to plunge directly into the vortex of the hurricane.

Brief rules for action are the following: Watch carefully for the earliest indications, recording observations of barometer, thermometers, wind and weather, for future reference. When there is

makes of lamps were used in the tests, their candle-power and efficiency being determined at intervals during a working period of 850 hours. There were fifteen commercial lamps of each make at first, but afterwards some additional lamps were sent from the factories. The methods of tests used were calculated to give accurate results, and much care was taken in the measurements, there being frequent comparisons of both current and potential measuring-instruments with standards; while the Methuen burner used in determining the candle-power was compared with standard candles, and found to be practically correct.

The results of the measurements can hardly be regarded as flattering to incandescent-lamp manufacturers. The initial efficiency of the lamps varied from about 3 watts to the candle-power (about fifteen 16-candle-power lamps to the electrical horse-power) to 5 watts to the candle-power (nine lamps to the horse-power). As time went on, however, the lamps, from the blackening of the globes and the increased resistance of the filaments, grew dimmer, until the candle-power had gone down in some cases to six or eight candles; while the efficiency had decreased, until in some cases lamps which gave a candle-light with an expenditure of 3 watts, finally required 7 watts to give the same light. The highest average efficiency for any make of lamps, for 800 hours, was 4.58 watts, the lowest 5.8 watts, per candle-power. Probably the most satisfactory of the lamps experimented on had an average efficiency of about 4.8 watts; the final candle-power, after 900 hours' service, being about 14, the initial being 16 candles.

An important point brought out in these tests is the marked decrease in the candle-power of commercial lamps, even after a moderate service. It is not at all satisfactory to consumers to have the lamp gradually decrease in brightness until it finally does not give enough light to read by, and to this cause may doubtless be attributed the comparatively slow introduction of the light. If the users are to replace the lamps, it is hardly in human nature to do so until they are broken, and a life of 2,000 or 3,000 hours is not uncommon. At the end of that time, a 16-candle lamp is giving about six candles, and that at a very low efficiency. There are many electric-light companies that guarantee twelve 16-candle lamps to the mechanical horse-power (equivalent to an efficiency of the lamp of about 3 watts to the candle). It is possible that a plant might give such results for a few hours; but, if these tests are to be trusted, none of the lamps in extended commercial use can do better than a candle-power for 4.8 watts, with the light at the end of 900 hours having 85 per cent of its initial brilliancy. The practical life of the lamp, then, is limited by two things,—the breaking of the filament, and the decrease of candle-power. This latter has not been recognized as it should have been, and Mr. Peirce's paper is of value in calling attention to it.

INHERENT DEFECTS OF LEAD SECONDARY BATTERIES.—A paper under this title was read at the meeting of the Institute of Electrical Engineers by Dr. Louis Duncan. It consisted mainly of a description of and deductions from a series of experiments which had been carried on by himself and Mr. Henry Wiegand during the past year; the principal points investigated being the loss of energy in charging and discharging such cells, with the causes of their deterioration. The cells experimented on were of the "grid" type, in which the active materials—peroxide of lead and spongy lead—are pasted into hourglass-shaped cavities in a cast-lead "grid." This type is the one almost universally used in commercial work, and it has so far been the most successful. The defects of these batteries lie (1) in the limited storage capacity, it being but one-eighth of the calculated value; (2) in the loss of energy in charge and discharge; (3) in the deterioration; (4) in the low discharge rate allowed by considerations of efficiency and length of life. The loss of energy exhibits itself by two effects,—a lower potential difference on discharge than on charge, and a loss in ampère hours between charge and discharge. The loss of energy must be traced to two things,—the production of heat or the formation of irreversible chemical products. It is known that the electro-motive force of a secondary battery is greater as the strength of the acid increases. When the strength is greatly diminished, there is a formation of irreversible sulphates of lead and a rapid corrosion of the plates. It is also known that discharge of the cell consists in a sulphating of both plates, causing a weakening of the

acid; charge results in desulphating, strengthening the acid. In the plugs of active material, where diffusion is slow, there must be considerable differences of density in the acid between charge and discharge, this being especially the case when the current rate is considerable. We can consider, then, that the charge is in strong acid; the discharge, in weak. To these considerations correspond the facts that the electro-motive force is higher on charge than discharge; that a rapid discharge lowers the electro-motive force, which, however, rises again after a period of repose; and that a rapid discharge causes a deterioration of the plates. To see if there were any ground for these suppositions, experiments were made on the rate of diffusion of acid from the plates, and it was found to be slow, especially with partly run-down plates, this corresponding to the fact that fully charged plates can be discharged more rapidly than partly discharged ones. To fix the losses of energy which result in heat effects, a cell was discharged in a calorimeter, and the rise of temperature and other data observed under various circumstances. The first thing that appeared was, that there was a much greater heating during charge than during discharge, there being sometimes an absolute fall of temperature in the latter case, when the C^2R effect was allowed for. This is partly due to the weakening and strengthening of the acid in the solution, there being of course a corresponding absorption or production of heat. Every one who has mixed acid and water is aware of the latter fact. Again, on charging or discharging for short periods, allowing the cell to stand idle for the same length of time, it was observed that the temperature continued to rise after the current had stopped. This was accounted for by supposing, that, the distribution of current in the plugs not being uniform, different parts of the same plug would be in different chemical states, and local currents would be produced, tending to make the plug uniform. These local currents cause losses, which exhibit themselves finally as heat. The principal cause of loss, however, seems to be due to the electrolysis of the solution, the loss from this cause appearing as heat, and in the liberation of oxygen and hydrogen from the two plates. The other losses are mainly due to the formation of irreversible products in the form of lead salts. In one discharge and charge cited, the total loss was 98 watt hours. Of these, 51 watts were accounted for in heat; the remainder must have been due to irreversible chemical actions. The heat losses may be classed as (1) the Joule effect, measured by C^2R ; (2) heating due to eddy-currents; (3) heating due to electrolysis of the solution into free hydrogen and oxygen. It should be noted that the alternate heating and cooling due to the strengthening and weakening of the acid is reversible, and therefore does not appear as a loss. Of the losses due to chemical actions during charge, which are not reversed on discharge, the most important, as far as loss of energy goes, is the electrolysis of the solution into free hydrogen and oxygen. The most important, so far as deterioration goes, is the formation of salts of lead on discharge in the weak acid in the plug, from the material of the support-plate. This last effect is exaggerated by rapid discharge, or by discharging until the formation of the more bulky sulphate of lead has greatly decreased the diffusion.

HEALTH MATTERS.

WOMEN'S BREATHING.—Our readers will doubtless remember the claim made by Dr. Thomas J. Mays of Philadelphia, that he had succeeded in demonstrating that the statement made in almost every text-book on physiology, that it was natural for women to breathe from the chest, was wrong; that the abdominal type of respiration, as ordinarily observed in men, was the natural type of women as well, and the costal type as seen in women is the result of modern dress. This claim he supported by the result of an examination of eighty-two American Indian girls. Dr. J. H. Kellogg, from an examination of Chinese and other women untrammelled by tight-fitting dress, finds the abdominal type present in them. Other observers, notably Hutchinson, in twenty-four girls whose waists had never been constricted by corsets or other appliances, found the costal type present. The question of what is the natural type of respiration may therefore still be regarded as *sub judice*, unless, which perhaps may be the truth, both types are natural under varying conditions, independent of dress.

FILTERS. — Dr. Currier of New York has recently been engaged in examining into the efficacy of filters and other means employed to purify drinking-water. His paper on the subject is published in the *Medical News*. He summarizes the result of the investigation as follows: Boiling sterilizes water, and within thirty minutes will have killed harmful bacteria. Drugs and other agents acting chemically, if used in amounts which are commonly safe, do not sterilize water. The prolonged heat which water undergoes in the usual process of distillation destroys all germs which may be in the water undergoing the process. Ordinary filters, even if satisfactory as strainers, fail to remove all bacteria from drinking-water. So far from lessening the number in the original water, the filtering substance may allow a more rapid multiplication than these micro-organisms would ordinarily undergo in the unfiltered water on standing; and the germs of disease, even if held back by the filtering substance, may be harbored in all filters. The finer the substance through which the water passes, and the lower the pressure, the more perfect is the action of the filter in holding back the bacteria. Of all substances thus far furnished for domestic filters, porous rebaked porcelain, carefully selected, has been found to be the best. If thick and strong enough to allow the use of a large surface, and the substance remain perfect (without flaw or break), this may yield a fair flow of clear water, free from all bacteria; yet, under our ordinary Croton pressure of one atmosphere or less, this yield is only in rapid drops, unless the apparatus be complex. To insure the permanency of this action, the filter should be occasionally sterilized throughout, by steaming or by other means; for, under prolonged pressure, various kinds of bacteria can go through, and in the copious organic matter collected on the filter some harmful micro-organisms can retain a high degree of vitality for weeks longer than they have ever been found to live in pure water. Where filtering is really necessary, it is in general best for the community that it be done carefully on a large scale through sand-beds upon which a fine layer of organic and inorganic matter is expressly produced by sedimentation, because of its valuable action in holding back the great majority of the bacteria. A bad water filtered is less desirable than a pure water in its natural state. When, therefore, filtration is employed because of real danger of infection, the filtered water should, as a rule, be furthermore boiled, as the entire absence of sediment and cloudiness does not insure that the bacteria of disease may not have made their way through the filter.

ASPHYXIATION BY ILLUMINATING-GAS. — At a recent meeting of the American Gaslight Association of Toronto, the following rules were given, to be followed when men are overcome by gas: 1. Take the man at once into fresh air. Don't crowd around him. 2. Keep him on his back. Don't raise his head nor turn him on his side. 3. Loosen his clothing at his neck and waist. 4. Give a little brandy and water, — not more than four tablespoonfuls of brandy in all. Give the ammonia mixture (one part aromatic ammonia to sixteen parts water) in small quantities, at short intervals, — a teaspoonful every two or three minutes. 5. Slap the face and chest with the wet end of a towel. 6. Apply warmth and friction if the body and limbs are cold. 7. If the breathing is feeble or irregular, artificial respiration should be used, and kept up until there is no doubt that it can no longer be of use. 8. Administer oxygen.

CANCER CONTAGION. — The contagiousness of cancer is still a mooted question. Dr. Arnaudet, in *La Normandie Médicale*, maintains the affirmative of the question, and gives the following facts to support his views: At Saint-Sylvestre-de-Cormelles, which has a population of about four hundred persons, there were seventy-four deaths in eight years. Of these, eleven were from cancer. In the neighboring villages of Normandy, although exact figures are wanting, the death-rate from cancer is said to be nearly the same. Of these eleven cases, six occurred within a limited area, and the order of their occurrence was such as to suggest a possible connection between them. The first case was that of a man living in an elevated portion of the hamlet; the next case was a man living on the side of the hill below the first; then three cases occurred almost simultaneously in persons living close together in the valley at the foot of this hill; and the sixth patient was a near neighbor of the first, on the plateau above the valley. In none of these cases could

any history of heredity be obtained, and they were all free from the reproach of alcoholic addiction. In five of the cases the cancer was seated in the stomach, and in the sixth the location of the disease was in the neck. Dr. Arnaudet believed that the germ of the disease, microbial in its nature, was carried in the water. None of the patients drank water, but they were all moderate consumers of cider, and that was the beverage that the author accused of being the carrier of the contagion. In making cider, the inhabitants of that region added water taken from the swampy ground; and the darker the color of the water, consequently the more impure, the higher it was esteemed as a diluent of the apple-juice.

NOTES AND NEWS.

THE invention and development of electric welding of solid bodies by Professor Elihu Thomson has been followed by a method of making endless pipes by the adaptation of the discovery to that purpose. This has apparently been done by Mr. Elias E. Ries of Baltimore. The smooth interior of the pipe is secured by the use of a removable refractory core, made of some insulating material, or the same object is attained by subjecting the interior of the pipe while being welded to compressed air or fluid pressure.

— In a description of the Calais harbor works in *Engineering*, occurs the following reference to the use of the water-jet for sinking the piles of the protecting dike or dam of the sluicing-basin: "The engineer in charge of this portion of the work sunk all the piles with the help of water-jets, — a system which has, of course, been in use for many years for sinking cylinders and iron piles, but which, we believe, had never been previously employed in this particular manner. The first trials were made in 1877, and the results obtained were so remarkable that the method was followed throughout nearly the whole of the work. Before this means was tried, the operation of driving a panel of sheet piling 9 feet high and 6 feet wide required 900 blows from a 1,300-pound weight, and the average time occupied was 8½ hours. The sand offered so much resistance, that the thickness of the piling had to be increased from 3-inch to 5-inch, and even then the wood was frequently broken. All these difficulties disappeared with the introduction of the water-jet, which was forced into the sand by hand-pumps through a 1-inch nozzle connected to rubber tubes. Much wider panels could be lowered in this manner, and the time of sinking was reduced to about one hour, while in many cases the operation was completed in 15 minutes. The number of blows from the falling weight never exceeded 50, and were only necessary to overcome the friction between the adjoining panels, which were tongued and grooved so as to make a tight joint. As a rule, the weight of the 1,300-pound top resting on the head of a 10-foot pile sufficed to drive it almost instantly into its place."

— An international congress of agriculture and forestry will be held in Vienna during the summer of 1890.

— We learn from the *American Lancet* that since its establishment the Minnesota Board of Medical Examiners have had eighty-six applications for examination for a license to practise medicine. Of these, six were refused admission because they had not taken three full courses of lectures of six months each. Of the eighty entering the examination, fifty-one were found able to pass the same, and twenty-nine were rejected as not possessing the knowledge of medicine required by the board. Of those passing, forty-nine are regular, and two are homœopathic. Of those rejected, eighteen were regulars, eight homœopaths, and three eclectic. Students from two-term medical colleges cannot even get a chance to be examined in Minnesota.

— An improved method of producing phosphorus has lately been patented in Paris. It consists, as described in *The Engineering and Mining Journal*, in treating bones or powdered mineral with nitric acid. A large proportion of the calcium is then removed from the solution — on the addition of potassium sulphate to liquid — in the form of calcium sulphate. The liquid then contains phosphoric acid and potassium and calcium nitrates. After removing the precipitated calcium sulphate by means of filtration, sufficient mercurous nitrate is added to precipitate the phosphoric acid as mercury phosphate. The phosphate of mercury so ob-

tained is collected and dried, and afterwards distilled with carbon, when mercury and then phosphorus are distilled over. The mercury may be reconverted into nitrate to serve as a second charge; and the liquors, after removing the mercury phosphate, yield, on adding more potassium sulphate, a solution from which potassium nitrate can be crystallized.

— According to the Rome correspondent of the London *Daily News*, the Pope has decreed, owing to the wishes expressed by Padre Denza more than a year ago, that the works for the Astronomical Observatory, to be erected in the Vatican, are to be begun at once. The site selected is the tower over the rooms occupied by the master of the Sacred College, it being the most elevated building of the Vatican Palace. The cost is estimated at a million of francs.

— It is reported in the Chinese press that the Marquis Tséng, so well known in Europe as the ambassador of China to this country, has been appointed to the control of the Foreign Science College in Peking.

— The Botanical Gardens at Edinburgh are now for the first time opened to the public on Sundays.

— Dr. John Gibson, who has for some time been engaged in superintending the physical work of the Fishery Board for Scotland, has recently completed a series of investigations which are likely to throw considerable light on the problems connected with ocean-currents. The detailed results will appear in the next annual report of the Fishery Board; but, from a preliminary note communicated to the Royal Society of Edinburgh, *Nature* states that it appears that two chemically distinct kinds of sea-water are present in the North Sea. The difference between these two waters is rendered perfectly distinct by sufficiently accurate determinations of the relation between chlorine and density, and is not due to river-water flowing into the North Sea. Water in which the relative proportion of chlorine is high reaches the North Sea from the surface of the Atlantic, round the north of Scotland and also through the English Channel, while water in which the relative proportion of chlorine is low flows into the North Sea from the north, and has been found on the surface as far north as 79° north latitude. The determinations of chlorine and density in the samples of ocean-water collected during the "Challenger" expedition, as published in the "Challenger" reports, seem to show that similar differences of composition exist in ocean-waters. To judge from these determinations, the mass of ocean-water, especially in southern latitudes, approximates in chemical composition to that flowing, as above mentioned, into the North Sea from the surface of the Atlantic. The water in which the relative proportion of chlorine is less appears to have been met with chiefly to the north of the equator and to the south-west of the principal outlets from the Arctic Ocean. This, as well as its chemical composition, seems to point to an Arctic origin.

— A catalogue of minerals and synonyms alphabetically arranged for the use of museums, by T. Egleston, Ph.D., has been published as Bulletin No. 33 of the United States National Museum. This catalogue was commenced in the year 1867, for use in arranging the collections of the School of Mines of Columbia College; but after many months' labor, when the work was nearly completed up to that date, it was abandoned on account of the press of other duties. In the last year, however, having occasion to make some investigations, and finding it almost impossible to get at the different synonyms of the various minerals on account of the imperfections of the indices of the various works, the work was taken up again and finished. It was found that the progress of the science since 1867 had been so great that the work previously done had to be altogether abandoned, so that all that is left of it is the general plan. It is hardly to be hoped that this catalogue is without errors, or that every name which has been published has been found. There are, however, several thousand more names contained in it than in any other published index.

— In 1885, after peace had been declared between France and China, the viceroy, Li Hung Chang, obtained the imperial sanction for opening military and naval schools at Tien-Tsin, where Chinese pupils could receive instruction in Western sciences. Consul

Smithers of Tien-Tsin says that the military school has been in operation five years, and has 150 pupils. It has four German professors, and the instruction is entirely in the German and Chinese languages. The naval school is divided into two departments, — the executive, for the training of naval officers; and the engineering, for the training of engineers. The number of pupils is 120, selected from the different provinces of the empire, and the length of the course is five years. The director of studies is assisted by three English professors, two of whom belong to the English Navy. The director himself, Yen Tsung Kwang, is a graduate of the foreign school at Foochow, and has served in the navy. A school for instruction in telegraphy was organized in 1880, and at present has forty-eight pupils. The instructors in this school are Danes, but the instruction is given in the English language. A local medical school, with a hospital attached, was founded some years ago by the viceroy. This school is now about to be re-organized, with an eminent foreign doctor at its head, the object being to qualify young men for the medical profession, and attach them to the army and navy as well as other branches of the public service. In addition to the schools already mentioned, Consul Smithers, writing under date of the 31st of December last, says that an Anglo-Chinese college was to be opened early in 1889. The building for this college was commenced in 1887. It is a fine Gothic structure situated on the left bank of the Peiho, and has accommodations for 300 students. In conclusion, the United States consul says, "When it is considered that hitherto the officers in the Chinese army and navy below the rank of general and admiral have been taken from the uneducated classes, and have obtained their commissions often by purchase, and that both branches of the service have been without a medical staff, the importance of the educational establishments at Tien-Tsin, promoted and fostered by the viceroy, cannot be overestimated."

— In an article on the Strong locomotive, in the May number of the *Engineering Journal*, it was stated that the run which the Strong engine made from Jersey City to Buffalo on the Erie Railroad was the longest continuous run of which we have any record, with the exception of a trip from Jersey City to Pittsburgh on the Pennsylvania Railroad some years ago. This statement, which was made from memory and without investigating the records, was, it appears, erroneous, and is corrected in the June issue. The train, which was famous at the time as the "Jarrett and Palmer Fast Train," and which ran from Jersey City to San Francisco in 84 hours, was drawn over the Central Pacific Railroad from Ogden to Oakland, 879 miles, by a single locomotive, which, like the Strong locomotive, made stops at several points. The greatest speed attained at any point on the journey was 60 miles an hour; the average speed for the whole distance, 36.8 miles an hour. The engine which made this very unusual run was an ordinary eight-wheel engine, No. 149, built by the Schenectady Locomotive Works, having 16 by 24 inch cylinders and 5-foot drivers. Only the necessary stops were made, and the full time was 23 hours, 59 minutes. As before noted, while neither this run nor the run of the Strong locomotive were continuous in a certain sense, both of the engines having made stops at several points, the run made from Jersey City to Pittsburgh on the Pennsylvania Railroad was really continuous, the engine having gone over the entire distance without stopping, water being taken up from the track-tanks on the way. This, of course, does not detract from the work done by the Strong engine; it only shows that such runs can be made on occasion; but their rarity goes to prove that the making them is too much for the ordinary locomotive.

— The United States steamship "Yantic," Commander C. H. Rockwell, U.S.N., commanding, sailed from New York, May 11, on a cruise off the coast to destroy derelict vessels, information regarding which was supplied by the United States Hydrographic Office. May 18, in latitude 37° 35' north, longitude 69° 55' west, she sighted the water-logged schooner "Alice Borda," of Camden, N.J., with deck-houses, hatches, and mizzenmast gone, mainmast out of step and leaning forward. Torpedoes were exploded astern, under the bilge on each side, under the heel of the bowsprit, and inside the port quarter, breaking her up very well. She was then set on fire, and, it is supposed, went down on the night of the

19th, although it was very difficult to destroy her, being lumber-laden. Unfortunately the "Yantic" encountered a hurricane of great violence the afternoon of the 21st, by which she was dismasted and compelled to give up her cruise and return to New York.

—Erastus Wiman, in a letter to the editor of the *Railroad Gazette*, states that the use of mica, ground by the cyclone pulverizer, as a lubricant, is assuming very great importance in connection with railways. The managers of a cyclone plant, which has been erected at Denver for the New Mexico Mica Mining Company, have ground mica to such an excessive fineness that the tests of the material as a lubricant have been very successful. A letter just received from Denver states that on the Rock Island Road the mica experiment was very satisfactory. They cooled off journals that came in heated, by applying mica, and the agent reports that one which came in very hot was sent forward as soon as the mica lubricant had been applied. The train despatcher received reports from different stations on the road, that it had cooled off, and was running all right. The experiments that have been made with mica lubricant and mica dope have been successful. The one was made with crude oil and mica, and the other with mica and the residuum from the wells, being a very much cheaper grade of oil. The officials of the Union Pacific and of the Denver and Fort Worth Roads have applied for the privilege of a test. It will be curious if this singular mineral should be found to be a lubricant, to serve so useful a purpose as that of a substitute for that crudest of devices, a huge clot of waste saturated with oil.

—The American steamship "Santiago," Captain Allen, passed through the centre of a water-spout on April 29, latitude 25° 38' north, longitude 76° 47' west. The detailed report forwarded by Chief Officer Calloway is one of the best ever received by the United States Hydrographic Office.

—Professor J. Burkitt Webb of Stevens Institute, Hoboken, N. J., is conducting a series of experiments with graphic reproduction processes, there being quite a need of some method whereby he can distribute diagrams and plates on graphical statics of a nature that cannot be set up in type, and yet would not repay the cost of engraving. Notwithstanding all the efforts of inventors, this problem does not seem to be solved, as the processes in vogue either yield poor results or involve much labor or cost.

—Recent analyses of commercial fertilizers and manurial substances sent to the Massachusetts State Agricultural Experiment Station for examination show that both cottonseed-meal and linseed-meal must be counted among our cheapest concentrated fodder ingredients, on account of the high commercial value of the fertilizing constituents they contain, varying from \$22.70 to \$25 per ton in the former, and from \$21.76 to \$24.04 in the latter. The samples of linseed-meal differed somewhat in their mechanical condition, which may be merely incidental. Their variation in composition, if obtained from the same lot of seed, is mainly due to the particular mode used to secure the oil of the seed. The old process consists in the use of a powerful press; the new process, in the abstraction of the oil by means of benzine or bisulphide of carbon. The latter mode of treatment aims, for economical reasons, at a more complete abstraction of the oil than the press can accomplish. To this circumstance it is mainly due that, as a rule, the meal obtained by the use of the old process contains in the same quantity more oil and less nitrogen containing organic constituents than that obtained by the new process.

—William Wallace, the chimney-repairer, is never out of work. He sets up his own peculiar device for staging, which enables him to complete a job in about the time that it takes to erect an ordinary staging. "Steeple Jack," as he is called, first places a long light ladder against the chimney that is to be operated on. Then, mounting it, he drives a peculiarly shaped iron pin into the brick-work, and binds the top of the ladder fast to this pin. Standing on the top round of this ladder, he drives another pin into the chimney as high above his head as he can reach. A rope is then passed over this pin, and made fast to a round in a second ladder about three feet from its bottom round. This ladder is then hoisted up until it rests on top of the first ladder. It is then made

fast to the lower pin; and then "Steeple Jack" mounts to the top of it, and, driving in another pin, secures the top round to that. From this ladder a third is hoisted as before; and Jack and the ladders, as many of them as may be necessary, continue to rise as far as may be desired. It is estimated that he has climbed about fifteen miles up into the air in this way. The only accident he ever met with was at Mansfield, Mass., when he fell from a chimney with a ladder. He landed in a tree, however, and escaped injury. His set of ladders is his only staging, and he can mount a 180-foot chimney in three hours. He raises his own brick and mortar by standing on top of the chimney and pulling them up. He learned his trade with the original "Steeple Jack Davis," in England, and has travelled extensively through Europe with his ladders, besides working in most of the large cities in this country.

—The Astley-Cooper prize, of a value of \$1,500, will be awarded in 1892. The question proposed is "The Influence of Micro-organisms upon Inflammation." The papers of those contesting for the prize should be written in English or accompanied by an English translation, and should be addressed before the 1st of January, 1892, to the Guy Hospital, London. The prize will not be awarded to two or three working together.

—The ship "Hvidjörnen" arrived at Copenhagen on May 21 from Greenland, having on board Dr. Fridtjof Nansen and his companions, who succeeded in crossing Greenland from east to west on snow-shoes. The members of the expedition received an enthusiastic welcome from a large crowd. Dr. Nansen has made further report of the experiences of his party in their journey across the Greenland ice. Before they got a landing on the east coast, they drifted for twelve days in the ice in the boats in which they had been left by a Norwegian sealer. They strove hard to reach the shore, but thrice, when on the point of succeeding, were carried out again to sea. For a whole day and night they expected to perish in the tremendous breakers of the sea against the ice rim. Dr. Nansen's account of his adventures, as it appears in the London *Daily News*, contains the following: "After two days, near the dreaded glacier of Puitsortok, we met a native camp of about seventy men, part of whom were bound for the north. We were glad of the meeting, and counted on valuable help from their knowledge of the currents on the coast. We were, however, disappointed, for, instead of taking the lead, they let us break the ice, and contented themselves with following in our wake. Some days after, having reached latitude 63°, some other natives who saw us took to flight, thinking us supernatural beings, though we made signs that we wished to be good friends. We took no brandy. At first it was warm in the daytime, and we walked at night; later we reversed the proceeding. At first there were plenty of wide crevices, and we had to be constantly on the alert to prevent an accident. On the third day a downpour of rain commenced, which kept us in our tent for three days. When we proceeded, no drinking-water was to be had: we were forced to melt the snow for cooking purposes and for our tin bottles. When we had altered our course, we got a side wind, and rigged masts and sails on the sledges, made of the tent flooring and tarpaulins. The wind abating, we had to give up sailing, and used our snow-shoes and skates. The drifting snow hampered our progress, but the surface was still even like a floor, and the ground still rose, till, at the beginning of September, we had climbed to a height of 9,000 feet. We were now on an extensive plateau like a frozen sea. We were more than two weeks passing over it. The cold was most severe, the thermometer falling below the scale, and, as I calculate, no less than 50° below zero Centigrade. One morning I found that in the thermometer under my pillow the spirit had receded below 40° into the ball. On Sept. 7 a severe snow-storm nearly overturned our tent, and on the next day we were overtaken by an awful drift. The tent was completely buried, and we had to dig it out. On the 19th there was again a favorable wind, and we lashed the sledges together, and, as we used the sails, it was unnecessary to pull. We held on to the sledges, standing on our snow-shoes as we rattled down the slope at a splendid rate. It was the pleasantest skating I ever had in my life. The same afternoon we sighted the first hilltop on the western coast. It was already dusk when we noticed a dark object ahead, and, rushing on, we discovered a fearful

crevice, which brought us to a sudden stop. It was high time: we were already on the very edge, and in two seconds more we should have been swallowed up in the bottomless abyss. We came across several more, and, in spite of the greatest care, we had other hair-breadth escapes. Once we were within an ace of destruction through a snow-bridge falling."

— The *Journal de la Chambre de Commerce de Constantinople* says that the cultivation of the red-pepper plant occupies a very important place among the several branches of cultivation practised in Turkey. This cultivation is chiefly making progress in the cantons of Karadja Abad, in the districts of Vardar Yenidje and of Védine, vilayet of Salonica. Formerly the production of red pepper was unimportant, for it was limited to the requirements of local consumption in the vilayet; but, since foreign countries have bought these peppers, cultivation has rapidly extended. The plant itself prefers a sandy and humid soil, where it grows sometimes almost in the water. It is estimated that the plant produces from 120 to 400 okes (oke = 2.84 pounds) of pepper per deunum (deunum = 40 square paces), according to quality. On an average, the expenses do not exceed 300 gold piastres for the cultivation of each deunum; and an oke of this pepper costs from 30 paras up to 5½ piastres, according to quality. The profit realized on the average is from 300 to 350 piastres per deunum. Harvesting only commences when the plants are entirely red. The produce of the first gathering is of superior quality; but that of the last is bad, as the pepper-plant reddens imperfectly in the autumn. This year the yield of red pepper has reached, in the canton of Yenidje Karadja Abad, the figure of 350,000 okes, and in that of Védine Karadja Abad, about the same amount. Of this yield, 45 per cent is exported to Europe; 30 per cent to Bulgaria, Servia, and Austria-Hungary; the remainder being sent to different parts of the Turkish Empire.

— The seed-trade appears to be destined to a very great expansion in California at a not very distant period. In the single county of Santa Clara, not less than 1,200 acres are now devoted to the production of garden-seeds. Over 60,000 pounds of lettuce-seed, and 120,000 pounds of onion-seed, have been shipped east from these grounds in a single season. In other counties a quite important business has been developed in the production of clover-seed, beans, and peas, for the supply of distant markets. While that State may not secure the monopoly of the seed-business, because good seeds are grown in the Atlantic States, the rapid increase of business in California indicates that one, at least, of the great centres of the seed-business, is to be in that State. The quality of many small seeds produced there, such as onion and lettuce, will have much to do in bringing the seed interest into greater prominence.

— The *June Magazine of American History*, with which its twenty-first volume is completed, opens with a sketch of "The Historic Capital of Iowa," now the seat of the State University, written by Mrs. Eva Emery Dye of Iowa City. The second contribution is an account of "The Ancient and Honorable Artillery Company of Massachusetts," by C. E. S. Rasay, M.A., the romantic story beginning with the first settlers of New England, and closing with the recent interchange of civilities between the Ancient and Honorable London and American Artillery Companies, the two oldest military organizations in the world. Following these, Georgia divides the honors of the number with Iowa and Massachusetts in an able article by T. K. Oglesby, on "Georgia and the Constitution." "The Last Twelve Days of Major John André," by Hon. J. O. Dykman, unfolds a suggestive field of study, and is to be continued through two future issues of the magazine. "A Boston Writing School before the Revolution," by William C. Bates, gives a picturesque picture of men and scenes in that early period. No feature of the June number, however, will be likely to attract more attention than the "Evolution of the Constitution," by C. Oscar Beasley. "The Study of the Mental Life of Nations," by Franklin A. Beecher; a hymn, "The Washington Centennial," by J. R. Barnes; "A Hundred Years to Come," by an unknown author; and three letters of Hon. Roger Griswold to his wife, contributed by Mrs. J. Osborne Moss, — may be noted.

— Since salicylic acid has been prohibited for the preservation of drinks and foods, some brewers have undertaken to use benzoic acid for the preservation of beers. In doses of five to six grams to the hectolitre, benzoic acid, if not especially poisonous, is at least active in preventing to a noticeable extent the assimilation of the albuminoids, and in modifying the mucous secretions. From this result digestive troubles in those persons who continue to use it for any length of time. Notwithstanding the small amount used industrially, it is probable that this use should be prohibited, as is that of salicylic acid. All antiseptics interfere with the normal digestive powers of the human system, and consequently with proper nutrition, and it is necessary that their use in the industries should come to an end.

— Professor F. E. Nipher made a verbal report at a meeting of the Engineers' Club of St. Louis, May 15, on a recent investigation into the performance of an engine working at a fixed cut-off without governor. Measuring the brake horse-power, the pressure of the supply-steam, and speed, he finds that the performance of the engine is represented by an hyperbolic parabolid, in which the lines of constant load and the lines of constant speed are rectilinear elements. At any fixed pressure, the relation between output and speed is represented by a parabola, the vertex of which represents a condition of maximum output. The condition of maximum output at any pressure is, that the moment of the force on the brake-arm must be one-half that moment, M' , which will bring the engine to rest, while the speed must be one-half that speed, N' , which the engine would have if the load were entirely removed. The maxi-

mum output is then in horse-power, $\frac{\frac{1}{2}\pi}{33000} MN'$. Professor Nipher

stated that he should proceed to determine whether mean effective pressure might be substituted for pressure of supply-steam. His present opinion was that it could. In that case, indicated horse-power could be represented as a function of the same co-ordinates, P and N . The equation for indicated horse-power is

$P N = \frac{33000}{\frac{1}{2}\pi R^2 L}$ (indicated horse-power), where R is piston radius,

and L is stroke. This is also an equation of the hyperbolic parabola, the axes of which are in an entirely different position from those of the surface of brake horse-power. Both surfaces contain the pressure axis. The difference between the two horse-power ordinates will give the real engine friction for any load and speed. It follows from these equations that the work consumed in the friction of an engine is constant for all loads if the speed is constant.

— Two naturalists, the one a Hollander, and the other a German, — Messrs. Kannegieter and Fruhstörfer, — have just started on a zoological exploration to Borneo, Java, and Sumatra.

— At the meeting of the Royal Meteorological Society, London, May 15, Mr. W. H. Dines gave an account of some experiments made to investigate the connection between the pressure and velocity of the wind. These experiments were made for the purpose of determining the relation between the velocity of the wind and the pressure it exerts upon obstacles of various kinds exposed to it. The pressure-plates were placed at the end of the long arm of a whirling-machine which was rotated by steam-power. The author gives the results of experiments with about twenty-five different kinds of pressure-plates. The pressure upon a plane area of fairly compact form is about a pound and a half per square foot, at a velocity of twenty-one miles per hour; or, in other words, a pressure of one pound per square foot is caused by a wind of a little more than seventeen miles per hour. The pressure upon the same area is increased by increasing the perimeter. The pressure upon a ¼-foot plate is proportionally less than that upon a plate either half or double its size. The pressure upon any surface is but slightly altered by a cone or rim projecting at the back; a cone seeming to cause a slight increase, but a rim having apparently no effect. At the same meeting Dr. C. H. Blackley told of an improved method of preparing ozone paper, and other forms of the test, with starch and potassium iodide. Some years ago the author made some experiments with the ordinary ozone test papers, but found that the papers did not always give the same result when

two or more were exposed under precisely the same conditions. He subsequently tried what re-action would take place between unboiled starch and potassium iodide when exposed to the influence of ozone; but the difficulty of getting this spread evenly upon paper by hand, so as to insure a perfectly even tint after being acted upon by ozone, led him to devise a new method of accomplishing this. Briefly described, it may be said to be a method by which the starch is deposited on the surface of the paper by precipitation; and, for delicacy and precision in regulating the quantity on any given surface, it leaves very little to be desired.

— A large number of experiments have been carried out at Innsbruck by Professor Peyritsch, and are recorded in the "Transactions of the Imperial Academy of Vienna," vol. xviii. i. p. 597, tending to show that double flowers may be artificially produced by the agency of a mite (*Phytoptus*). It seems that the professor was examining a wild double flower of *Valeriana tripteris*, and discovered that it was infested with the mites in question. He transferred these mites to other plants, chiefly of the orders *Valerianaceae* and *Cruciferae*, and a few *Scrophularineae*, *Compositaceae*, and even others; but the best results were obtained in the first named. Various kinds of doubling were produced, such as petalody of the stamens and pistil, proliferation and duplication of the corolla, etc., as well as torsions and fasciations of the shoot. The leaves were also affected, the margin showing teeth like those of a comb. By infecting the plant at different times, either the leaves or the flowers may be influenced, and it appears that the parasite must attack the organ in its earliest stages. Professor Peyritsch thinks that there are certain mites which produce double flowers in certain plants, as the mites in which he was particularly interested were always most abundant in certain species, and less so in others.

— The introduction of *Phylloxera* into Asia Minor appears to have been the result of a deliberate importation of the vines from a country where the disease was known to exist.

— An interesting note, by Mr. Arthur A. Rambaut, on some Japanese clocks lately purchased for the Dublin Science and Art Museum, has been reprinted from the "Proceedings of the Royal Dublin Society." These clocks, though differing in other respects, agree in this particular: that the time is recorded, not by a hand rotating about an axis, but by a pointer attached to the weight, which projects through a slit in the front of the clock-case. This pointer travels down a scale attached to the front of the clock, and thus points out the hour. Mr. Rambaut has consulted several persons who have been resident for some time in Japan, but none of them has ever seen clocks of like construction in actual use. A young Japanese gentleman to whom the specimens have been shown, says that he has heard of such clocks being used in rural parts of Japan about twenty or thirty years ago, but that they have been almost completely superseded by clocks made on the European plan.

— An international congress of chronometry will be opened at the National Observatory, Paris, on Sept. 7. An influential organizing committee has been formed, of which Vice-Admiral de Fauque de Jonquières has accepted the presidency. Those who wish to become members should communicate with the secretary, M. E. Caspari.

— *Engineering* reports that arrangements have been made for the despatch of another exploring and prospecting expedition for the Australian interior. The funds for the undertaking are to be chiefly provided by the Central Australian Exploring Association, which is an offshoot of the South Australian branch of the Geographical Society. Baron von Muller of Melbourne has taken an interest in the enterprise, and it is hoped that a portion of the funds available for exploration in the hands of the Geographical Society in Victoria will be placed at the disposal of the expedition. The leadership of the party has been undertaken by Mr. W. H. Tietkens, an experienced Australian explorer. The party will probably consist, in addition to the leader (upon whom will also devolve the duties of botanist, prospector, mineralogist, and surveyor), of three men and a black boy, with twelve camels, two horses, and provis-

ions for six months. The starting-point will be Alice Springs, and the expedition, travelling ordinarily at the rate of one hundred miles per week, except when engaged in the work of prospecting, will proceed to Lake Amadens with a view to examining carefully the surrounding country.

— The Paris correspondent of the London *Daily News* says the Zoological Society of France has warned the French Government that a great ornithological calamity is impending. The Department of the Bouches du Rhône has hitherto been one of the chief landing-places for swallows coming from Africa. Engines for killing them, formed of wires connected with electrical batteries, have been laid in hundreds along the coast. When fatigued by their over-sea flight, the birds perch on the wires, and are struck dead. The bodies are then prepared for the milliner, and crates containing thousands of them are sent on to Paris. This has been going on for some years, and it has been noticed this spring that swallows have not landed on the low-lying coast, but have gone farther west or east, and that they go in larger numbers than formerly to other parts of Europe. There are places, says the Zoological Society in its petition, where they used to be very numerous, but which they have now deserted, although there has been no falling-off in the gnats and other flying insects on which they live.

— A sub-committee of the Royal Agricultural Society of South Australia has undertaken to raise subscriptions in aid of the destruction of sparrows in South Australia, and it is proposed to have monthly competitions in the production of sparrows' heads and sparrows' eggs. These competitions will take place after the next autumn show in Adelaide. At the autumn show there will be a grand prize competition, when prizes of £2, £1 10s., 10s., and 5s. will be offered for the largest numbers of sparrows' heads, and the same value in prize-money will also be offered for the largest numbers of sparrows' eggs. Additionally to this, every competitor who fails to secure a prize, and yet brings in one hundred or more heads or eggs, will receive a bonus of 2s. 6d., and any one producing under one hundred and not less than fifty heads or eggs will receive a bonus of 1s.

— A report comes to the Entomological Museum, Washington, from Mr. J. W. Beach of Batavia, Boone County, Ark., to the effect that a general alarm prevails in that section of the country for many miles around in regard to the chinch-bug. They did a considerable amount of damage there last year, and those that wintered over have already destroyed many fields of grain this spring. The wooded country in places is reported full of them; so much so, that the people are contemplating setting fire to their woodlands.

— The weight of the smoke-cloud which daily hangs over London has been estimated by Professor Chandler Roberts, says the *Engineering Times*, to amount to about 50 tons of solid carbon and 250 tons of carbon in the form of hydrocarbon and carbonic-oxide gases. Calculated from the actual result of tests made by the Smoke Abatement Committee, the value of coal wasted in smoke from domestic grates amounts, upon the annual consumption of 5,000,000 of people, to £2,256,500. The cost of cartage on this wasted coal is calculated to be £268,750, while the unnecessary passage of about 1,500,000 horses through the streets in drawing it, adds seriously to the cost of street cleaning and repairing. Then there is the cost of taking away the extra ashes, £43,000 per year. Summing it all up, the direct and indirect cost of waste coal may be set down at £2,600,000, plus the additional loss from the damage done to property caused by the smoky atmosphere, estimated by Mr. Chadwick at £2,000,000, the whole aggregating £4,600,000.

— "The Summer Care of Children" is made the subject of a timely paper in the June number of *Babyhood*, by Dr. H. D. Chapin. Equally practical is the article on "Nursery Cookery," by Dr. Sarah E. Post. Other articles of interest to parents are, "The Musical Education," "Where shall we spend the Summer?" "Botany for the Little Ones," etc. Much valuable advice is offered concerning earache, the promotion of the sucking power, and the many questions of food, dress, etc., asked by correspondents.

SCIENCE:

A WEEKLY NEWSPAPER OF ALL THE ARTS AND SCIENCES.

PUBLISHED BY

N. D. C. HODGES,

47 LAFAYETTE PLACE, NEW YORK.

Subscriptions.—United States and Canada.....	\$3.50 a year.
" Great Britain and Europe.....	4.50 a year.
Science Club—rates for the United States and Canada (in one remittance):	
1 subscription 1 year.....	\$ 3.50
2 " 1 year.....	6.00
3 " 1 year.....	8.00
4 " 1 year.....	10.00

Communications will be welcomed from any quarter. Rejected manuscripts will be returned to the authors only when the requisite amount of postage accompanies the manuscript. Whatever is intended for insertion must be authenticated by the name and address of the writer; not necessarily for publication, but as a guaranty of good faith. We do not hold ourselves responsible for any view or opinions expressed in the communications of our correspondents.

VOL. XIII.

NEW YORK, JUNE 7, 1889.

No. 331.

CONTENTS:

SOME NEW ELECTRIC MOTORS.....	431	RECENT DISCOVERIES IN CENTRAL AFRICA.....	442
WATER-FILTRATION <i>John A. Caldwell</i>	432	A SANDY SIMOOM IN THE NORTH-WEST.....	444
THE USE OF SPIRIT AS AN AGENT IN PRIME MOVERS.....	433	THE SPIDER-BITE QUESTION.....	444
WEST INDIAN HURRICANES.....	434	BOOK-REVIEWS. A Text-Book of Pathology, Systematic and Practical.....	445
ELECTRICAL NEWS. The Average Efficiency of Incandescent Lamps.....	435	Elementary Text-Book of Zoology.....	445
Inherent Defects of Lead Secondary Batteries.....	436	Pestalozzi: his Aim and Work.....	445
HEALTH MATTERS. Women's Breathing.....	436	The Electric Motor and its Applications.....	446
Filters.....	437	Examination of Water for Sanitary and Technical Purposes.....	446
Asphyxiation by Illuminating-Gas.....	437	The Bacteria in Asiatic Cholera.....	446
Cancer Contagion.....	437	First Book of Nature.....	446
NOTES AND NEWS.....	437	AMONG THE PUBLISHERS.....	446
EDITORIAL.....	442	LETTERS TO THE EDITOR. A New Chemical Experiment.....	449
Preliminary Work on the Next Census.—Science, Falsely so called.		<i>J. R. Eaton</i>	449
		Relative Frequency of Letters and Combinations.....	449
		<i>H. Y. T.</i>	449

THE VARIOUS MEDICAL ASSOCIATIONS and the medical profession will be glad to learn that Dr. John S. Billings, surgeon in the United States Army, has consented to take charge of the "Report on the Mortality and Vital Statistics of the United States," as returned by the eleventh census. As the United States has no system of registration of vital statistics, such as is relied upon by other civilized nations for the purpose of ascertaining the actual movement of population, our census affords the only opportunity of obtaining any thing near an approximate estimate of the birth and death rates of much the larger part of the country, which is entirely unprovided with any satisfactory system of State and municipal registration. In view of this, the Census Office, during the month of May this year, will issue to the medical profession throughout the country 'physician's registers' for the purpose of obtaining more accurate returns of deaths than it is possible for the enumerators to make. It is earnestly hoped that physicians in every part of the country will co-operate with the Census Office in this important work. The record should be kept from June 1, 1889, to May 31, 1890. Nearly 26,000 of these registration-books were filled up and returned to the office in 1880, and nearly all of them used for statistical purposes. It is hoped that double this number will be obtained for the eleventh census. Physicians not receiving registers can obtain them by sending their names and addresses to the Census Office; and with the register, an official envelope, which

requires no stamp, will be provided for their return to Washington. If all medical and surgical practitioners throughout the country will lend their aid, the mortality and vital statistics of the eleventh census will be more comprehensive and complete than they have ever been. Every physician should take a personal pride in having this report as full and accurate as it is possible to make it. All information obtained through this source will be held strictly confidential. It is equally important to the country that the returns in relation to farm-products and live-stock should be full and correct. The enumerator in the house-to-house visit he will make during the month of June, 1890, is constantly met with the fact that farmers keep no books, and hence returns are not infrequently guess-work. The census year begins June 1 next, and ends May 31, 1890. If farmers throughout the country would note this fact, and keep account of the products of their farms during the census year, it would be of material aid in securing reliable returns for the eleventh census.

SOME ONE RECENTLY SENT Professor C. M. Woodward, director of the Manual Training School, Washington University, St. Louis, Mo., a copy of a small periodical called "Microcosm," in which there was a prize essay by a Mr. Reuben Hawkins of Chillicothe, Mo., which has some interest. This article Professor Woodward picks to pieces in *The Teacher* for May. The author begins by quoting the familiar ideal experiment of firing a cannon-ball horizontally from the top of a tower, under the assumption that the force of gravity is constant, and that there is no resisting medium. The question is as to the time occupied in reaching a lower horizontal plane. Mr. Hawkins says that the common answer that the time occupied by the projectile is the same as the time occupied by a ball falling vertically from the muzzle of the gun to the same horizontal plane, is wrong, and his prize money is won by an argument in support of his assertion. Professor Woodward states that he has no idea who Mr. Hawkins is, nor does he know what facilities he has had for acquiring correct notions of mechanics and correct methods of reasoning, and had his essay not been indorsed by the editor, A. Wilford Hall, Ph.D., LL.D., in a commendatory note as well as by a prize, he should not have spent a moment on it. But when he sees such unspeakable trash commended and rewarded by a man who claims to have some understanding of the principles of physics, he feels constrained to protest. Mr. Hawkins's argument begins with some propositions in regard to the resultant of two forces acting on the same body, substantially as follows: If two equal forces act in direct opposition, the resultant is nothing. If two equal forces act in the same direction or in conjunction, the resultant is equal to their sum, or twice one of the component forces. Now, if one of the forces is turned to a mean position between the two just considered, that is, to a position at right angles to the second force, or in "half position" as Mr. Hawkins calls it, the resultant must be the mean of the former resultants. The mean of zero and two is one. Hence the resultant of two forces at right angles to each other is just equal to one of them. All this, and more of the same kind, Dr. Hall indorses as follows: "The foregoing article from the able pen of Mr. Hawkins was written substantially before our prize offer was published. From its highly scientific character, however, and from the fact that this number of the *Microcosm* will reach more than twenty thousand professors and teachers, we deemed it important to give it the position of Prize Essay No. 1." How far such teaching may do mischief is a question, but its existence is worthy of occasional note.

RECENT DISCOVERIES IN CENTRAL AFRICA.

THE results of Van Gèle's exploration of the Obangi, of Junker's discoveries on the Upper Welle, Stanley's great journey up the Aruvimi, and Delcommune's ascent of the Lomami, have materially added to our knowledge of Central Africa, the river systems of

which were, until a few years ago, one of the most baffling problems to geographers. On the accompanying sketch-map the rivers of Central Africa are shown according to the present state of our knowledge. The numerous large rivers south of the great bend of the Kongo offer an excellent means of communication, and will undoubtedly be of great help to the commercial development of that region. The hopes that were for some time entertained, of finding an equally valuable commercial route north of the Kongo, have not been fulfilled, navigation being interrupted by numerous rapids. Stanley's expedition has proved that there is no prospect of ever opening a trade-route from Stanley Falls to the Albert Nyanza, and that the natural outlet of the lake region must be by way of the east coast. On the other hand, Mr. Delcommune's ascent of the Lomami has proved that the market of Nyangwe is easily accessible from the west coast, the river being navigable at a point only three

no serious obstacles are found on the route, and that the cost of construction will be moderate. It is estimated that the journey from Matadi to Stanley Pool will occupy two days. Thus the termini of navigation on the upper and lower river will be connected by an easy route. The commercial examination of the interior seems to give good promise, and ere long we shall see a trade spring up sufficient to warrant the construction of a railroad. At present serious attention is given to the improvement of the caravan-route near the bank of the Kongo. The attempts at stock-raising are giving fair results, and soon transport on carts drawn by oxen, or on the back of oxen, will take the place of the caravans of carriers.

According to the *Mouvement géographique*, the general trade of the Kongo Free State amounts at present to 7,392,348.17 francs, or approximately \$1,500,000, the staple produce being palm-kernels,

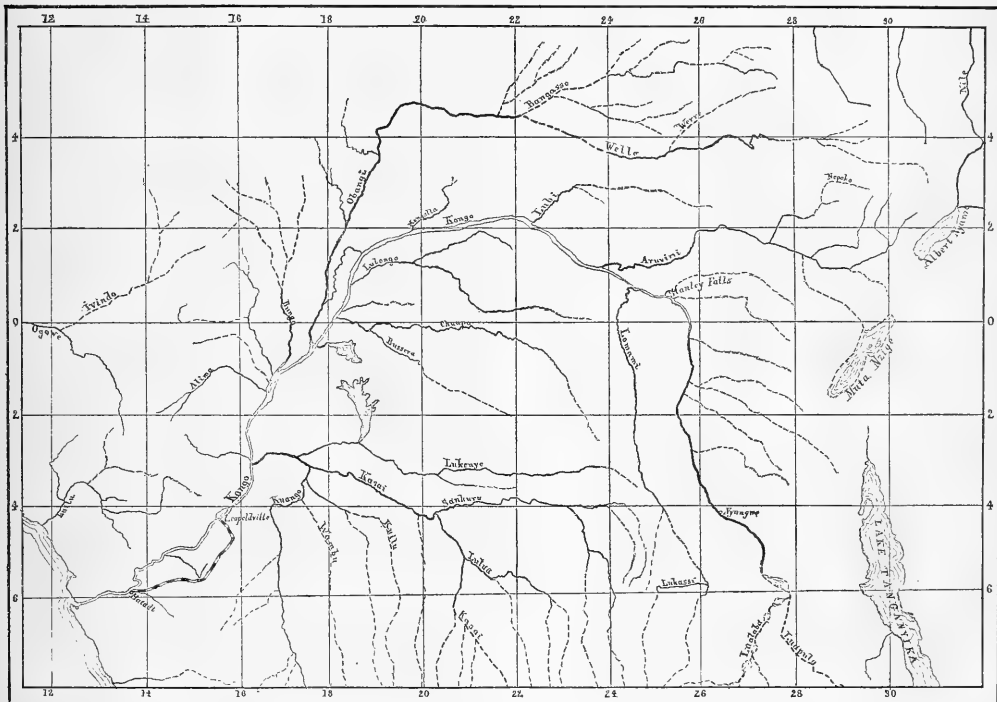

MAP SHOWING RECENT DISCOVERIES IN CENTRAL AFRICA.

days' journey distant from Nyangwe. The importance of this fact cannot be rated too highly. Stanley Falls seemed to be the terminus of navigation on the Kongo; and the countries Urua and Katanga, which were first visited by Reichard, appeared to be almost inaccessible. The Lomami, however, offers an easy means of access, and will lead to the opening of these remote regions. This is the more important, as, according to Reichard, the Lualaba above Nyangwe is navigable as far as Lake Upemba.

As will be seen from our map, there remains one great unknown country bounded by the Kongo on the west side, and by a line running from the north point of Lake Tanganyika to the south point of Lake Albert Nyanza on the east side. In this region the Arabs have recently made rapid progress, and villages are being devastated and depopulated. Trade is being organized at the cost of the well-being of the natives, and the great markets on the Kongo are supplied by the slave-caravans ravaging this region.

In the present map the planned railroad from Matadi to Leopoldville has also been indicated. The surveys have proved that

ivory, and palm-oil. Coffee has recently attained considerable importance. The growth of the state is such, that, for administrative purposes, it had to be divided into eleven districts, each of which, two only excepted, has its chief station. Three of these districts comprise the Lower Kongo, five the Upper Kongo and the adjacent territory, one the Kasai, one the Aruvimi and Welle, and the last the Lualaba.

The rapid progress in opening Central Africa, starting from the west coast, is the more welcome, as there seems to be no end to the political complications in East Africa. Although Lieut. Wissmann has defeated the Arabs, their resistance has not been broken, and it is doubtful how far into the interior his influence will expand. Military expeditions into the interior of Central Africa are hardly possible, on account of the vastness of the territory and the difficulties offered by the climate, and the effects of long-continued wars must be to close the routes from Zanzibar to the lake region. If the Kongo Free State is successful in keeping the devastating slave-trade out of the greater part of its territory, it will doubtless

be successful in opening Central Africa to the influence of European civilization, to the benefit of both the African and the needs of our culture.

A SANDY SIMOOM IN THE NORTH-WEST.¹

MAY 6 and 7, 1889, will long be remembered by the residents of the North-west. On those days culminated the violence of the dry, south-easterly wind which had prevailed in some portions of the North-west, particularly in central and eastern Dakota, for several days previous. The wind itself, while not specially violent, varying from twenty to forty miles an hour, and perhaps in some places fifty miles an hour, was remarkable for carrying with it clouds of dust and sand, which filled the air and penetrated into houses, and blinded the traveller who happened to be caught in the roads, and compelled the cessation of nearly all outside labor. The wind prevailed over a large area. It seems to have reached farthest east, and been most violent, on the 6th and 7th of the month. The newspapers gave telegraphic accounts of it in Nebraska, South and North Dakota, Iowa, and Minnesota. It probably also affected western Wisconsin and considerable portions of Missouri.

A strong south-easterly parching wind, prevailing for several days, about that time in the spring, is a familiar fact to old residents who have taken note of the peculiarities of the north-western climate. It more frequently comes after spring vegetation is more advanced than it was this season on the days mentioned; and its effect on small, tender twigs is disastrous. It is enervating to all animals, and merciless on the wilting vegetation. But prior to this wind, which was followed everywhere by copious rains, the spring of 1889 in the North-west had been dry; and this was intensified in its effect on young vegetation by the preceding dry and open winter. All springs and streams were unwontedly low: hence the soil was loose, and exposed to the attack of this wind. Grass was not so large as usual, and did not shield the soil. Extensive prairie and forest fires had recently denuded large tracts of much of the protection which vegetation otherwise would have furnished. Circumstances were favorable, therefore, for the air to become filled with flying particles, caught up from the ploughed fields, from the blackened prairies, from the public roads, and from all sandy plains. These particles formed dense clouds, and rendered it as impossible to withstand the blast as it is to resist the blizzard which carries snow in the winter over the same region. The soil to the depth of four or five inches in some places was torn up, and scattered in all directions. Drifts of sand were formed, in favorable places, several feet deep, packed precisely as snow-drifts are under a blizzard. It seemed as if there were great sheets of dust and dirt blown recklessly in mid-air; and when the wind died down for a few moments, the dirt, fine and white, almost seemed to lie in layers in the atmosphere, clouding the sun, and hiding it entirely from sight for an hour or more at a time. It was so fine, and penetrated the clothing so, that life was burdensome to those who must face the storm. Mr. C. W. Fink of Woolsley, near Huron, Dak., stated that it was almost impossible to live out of doors at some periods of the storm, and that he would "much rather take his chances in the big blizzard of two years ago." While on his way to St. Paul over the St. Paul, Minneapolis, and Manitoba Railroad, Mr. Fink said the train passed through what was apparently a storm of fine dust which seemed to be almost white. It looked much like a snow-storm, and the sun was hid. It was impossible to distinguish obstacles at a distance of more than a few feet away. These phenomena in their intensity did not appear at Minneapolis; but they were witnessed in the more open or originally prairie tracts, and are given on the authority of others. During a residence of seventeen years at Minneapolis, the writer has not before witnessed any thing that would compare with this simoom-like storm.

The occurrence of this storm has a bearing on theories of the origin of the loess. Its area is that over which the loess is abundant. It would not take long for any beholder to be convinced that there was enough material being transported in the wind to constitute, when deposited in water, or even piled up as dunes and spread as surface sheets, after a few years, a stratum as thick as,

and constituted like, that of the Missouri-Mississippi Valley. Given such a wind over the same region, periodically, under the same parched condition of the surface, it would only require an expanse of water in which this dust could settle, to form a loess clay, or loam. With the accompanying and following rains, other particles would be washed down from the lands, mingling with some strata of sand or of gravel, and a transition from loess to drift-sand would be built up such as has been described in several places.

THE SPIDER-BITE QUESTION.

THE following item appeared in the *Evening Star* (Washington) for March 12, 1889, and is a fair sample of the newspaper reports in reference to spider-bites which are so common: "Mr. Tileston F. Chambers, son of Mr. D. A. Chambers of this city, came home from Princeton with several fellow-students to spend the inauguration holidays. On Saturday, March 2, he was bitten twice on the arm by what the doctor said must have been a black spider, with the most alarming results. Blood-poisoning and jaundice followed, but by careful treatment he is now rapidly recovering. The physician said that another bite would undoubtedly have proved fatal."

Learning by correspondence from Mr. D. A. Chambers that the physician in charge was Dr. Z. T. Sowers of Washington, a well-known and prominent practitioner, a representative of the Entomological Bureau, Washington, called upon Dr. Sowers, who stated that he knew little more than was given in the newspaper statement. He said that he had had several such cases in his practice, and that he was accustomed to attribute these bites to black spiders, for the reason that he knew of no other insect found in such localities which could produce the effect. The room in which young Mr. Chambers was bitten was one which had long been disused, and he occupied it on the night of March 2, for the reason that the rest of the house was full of inauguration visitors. Thus there is nothing special connected with this instance.

Professor Riley, United States entomologist, is under the impression that certain of these cases result from the bite of the blood-sucking cone-nose (*Conorhinus sanguisuga*),—an insect which is occasionally found in houses, and which is able to inflict a very severe wound with its beak.

Evidence in regard to fatal bites is very weak, with the exception of the genus *Latrodectus*, and this genus is never found in out-houses or disused rooms. Dr. Elliott Coues calls attention to the fact, that, if the *Latrodectus* stories are true, we have a case in this creature of the most powerful poison known. With the most poisonous snakes an appreciable quantity of poison, say one or two drops, is injected into the wound, but with the *Latrodectus* an infinitely smaller quantity seems to produce as strong an effect.

In this connection the editor of *Insect Life* quotes an item for the reliability of which the *Scientific American* is responsible: "Professor Breeger has recently investigated the poisons of spiders. He found that the Russian varieties of spider, *Phalanchium* and *Trochosa* (*Tarantula*), are non-poisonous, but that a third, *Caracurt*, or 'black wolf,' secretes a powerful poison, forming twenty-five per cent of its whole weight. This substance is a peculiar unstable alkaloid, destroyed at 60° C. or by alcohol. Introduced into the circulation of warm-blooded animals, one-thirtieth of a milligram per kilogram of the animal treated was sufficient to cause death. It exceeds in power all known vegetable principles and prussic acid, being comparable in toxicity with the poison of snakes."

The following letter from Mr. R. Allan Wight of New Zealand, also bearing on the subject, is appended: "What Dr. Wright told you about the *Katipo* is perfectly correct. I was then living close by, and knew all the parties and all the circumstances, and my sons also remember it all. It was as clear a case of *Katipo* poisoning as possible; and the man said he saw the spider bite him, and minutely described the spider, which description tallied exactly with its proper one. A case occurred at Whangarei a few weeks ago, where a man was bitten and suffered a good deal, and I have written to the medical man who attended him, and will let you know the result. I am also going soon on another long tour

¹ From the *American Geologist*.

in the north, where I shall be able to get many tales and reliable information from both natives and white men as to the *Katipo*, and will let you know when I come back. I drove over to a man who is said to have lost his arm through a *Katipo*, but I found that he does not know one when he sees it, did not see the bite inflicted, was in a place where the *Katipo* does not live, and when the arm was removed the bone was diseased (honeycombed). That is one of those tales people hear, and which make it difficult to believe any thing. I feel certain the *Katipo* is a very dangerously poisonous spider, but I never but once saw a case with my own eyes. It was many years ago, and I was out with a war party of Maoris. One night we found ourselves in an unpleasant position, as far as they were concerned. On our rear there were a number of nice hollow places to sleep in; but as these were Maori ovens, in which men had been cooked for a cannibal feast, the natives not only would not sleep in them, but they would not let me: so we lay down on the bare shingle beach, with no tent, in a high wind, and before us at a short distance was an island that is (they say) inhabited by evil spirits; so, with spirits both before and behind, we lay awake, talking in subdued whispers.

"I had my head on a rush bush; but they would have me shift it on to a rock, because they said the *Katipo* lived in the rushes by the seaside. I was anxious for them to sleep, knowing that to-morrow we would want all our strength; but it was no use, for by and by a man screamed out that the *Katipo* had bitten him, and in a moment lights were brought, and, sure enough, the *Katipo* was there, within a foot of the wound, under his mat. The arm swelled, but not so much as to give alarm. What alarmed me more were his weakness and languor, and the lowness of his pulse and his heart-action. The poison certainly was a powerful narcotic, if symptoms go for any thing. I gave him all the brandy we had, and the natives pretty well burned his wound, and rubbed and rubbed at him till they got him into a perspiration; but he did not properly recover for several days, and, if one had only known, it would have been a mercy to have let him die (which I believe he would). So I thought when I saw him gasping his life away with blood and froth flowing from his mouth. Ugh! That is one of the several scenes I do not care to think about. By the by, I could not get the specimen. The Maoris burned it, as they said the *Katipo* is an 'evil spirit, and, if we did not burn it, the man would die.' I have many chiefs here, and I asked them only to-day, but no one ever heard of but one *Katipo*, — the black spider, with a vermilion spot on the abdomen."

BOOK-REVIEWS.

A Text-Book of Pathology, Systematic and Practical. By D. J. HAMILTON, M.B. Vol. I. London and New York, Macmillan. 8°. \$6.25.

FROM the pen of the professor of pathological anatomy of the University of Aberdeen we should expect a text-book of pathology which would be both systematic and practical, and we are not disappointed. The first volume only has been published; but the second is in process of preparation, and will be issued with the least possible delay. The contents of the volume before us are divided into three parts. Part I. treats of the technique, including the *sectio cadaveris*, or autopsy, the preparation of tissues for detailed examination, and the microscope. In this portion of the work, practical bacteriology also is discussed. Part II. deals with general pathological processes, including infiltrations and degenerations, inflammation, suppuration, healing and organization, ulceration, and dropsy. In Part III. we find considered diseases of the various organs and tissues, new formations and tumors, diseases of the blood, the heart, and the blood-vessels. In an appendix are thoroughly described the methods of making casts and models, which are most important adjuncts to every pathological museum. The author promises us that in the second volume he will discuss systematic bacteriology *in extenso*; and, as this subject has now become so important, we shall look for this volume with great interest. The methods described in the volume before us are, as a rule, the most advanced and the best. We think that the method of making Esmarch's tubes might have received more attention

than has been given to it, on account of its advantages over Koch's plate method. Nothing is said of rolling these tubes on ice, which is now done in most of the American laboratories, perhaps for the reason that the method is not known in the British Isles. It will be found by those who try it superior to cold water. Taken as a whole, we have nothing but praise for Mr. Hamilton's book; and, if it receives the attention of the medical profession of this country as it deserves, it will soon become the leading text-book of pathology in our medical colleges.

Elementary Text-Book of Zoölogy. By Dr. C. CLAUß. Tr. and ed. by Adam Sedgwick, M.A., and F. G. Heathcote, M.A. 2 vols. 2d ed. London and New York, Macmillan. 8°. \$8.

MR. SEDGWICK, lecturer of Trinity College, Cambridge, and examiner in zoölogy in the University of London, undertook the translation of this work of Claus ("Lehrbuch der Zoologie") to supply a want, which had long been felt in England by both teachers and students, of a good elementary book on this subject. The reputation of Professor Claus's works on zoölogy in Germany, and indeed throughout the civilized world, naturally suggested this one to Professor Sedgwick as the one best adapted to supply the deficiency which existed, and in the two volumes before us we have the most complete elementary text-book on this subject in the English language. Others, to the extent to which they go in the treatment of special subjects, may be equally good; but none that we have seen can claim the same degree of excellence and completeness combined. The work is illustrated with 706 woodcuts; and as to its general excellence, we need but call attention to who its publishers are.

Pestalozzi: his Aim and Work. By BARON ROGER DE GUIMPS. Tr. by Margaret C. Crombie. Syracuse, C. W. Bardeen. 12°. \$1.50.

THIS is a convenient biography of Pestalozzi by one of his own disciples; and Miss Crombie has rendered a service to English and American educators by bringing it out in their own language. The arrangement of the work is not always the best, and some points are not made so clear as might be wished; but nevertheless it gives a very fair account of Pestalozzi's life, and of his educational theory and practice. He was born in 1746, and quite early showed that interest in the education and moral elevation of the masses which was the ruling motive of his life. He first undertook to be a clergyman, but, not succeeding in that profession, attempted that of law, from which he was excluded by the Swiss authorities, to whom his political views were obnoxious. He then engaged for some years in farming, having in the mean time taken a wife; but his want of business skill led to ultimate failure, so that he was reduced almost to beggary. After this he tried his hand at authorship, in which he had some successes and some failures; and it was not until he was over fifty years of age that he found his true vocation of teaching, which thereafter continued to be his occupation most of the time during the remaining thirty years of his life. Every one of his schools ultimately came to a disastrous end, owing in great part to his own want of business skill and managing tact. Nevertheless, he was able to put in practice his new method of teaching, which, in the opinion of his admirers, is the greatest improvement ever made in education.

What this method was, his biographer does his best to explain; yet he confesses in the end that "the world has not yet got a clear answer to the oft-repeated question, 'What is Pestalozzi's method?'" It seems evident, however, that it consisted mainly in what are now called object-lessons combined with drawing, while learning from books was almost totally excluded. He had, we are told, an utter contempt for book-learning, and he seems to have thought that the whole educational practice of the world for two thousand years had been wrong, and that nothing but a revolution would set things right. The accounts given in this book, however, do not justify any such inference. Pestalozzi tried his method first on his own son, with the result that the boy was not educated at all, but grew up an ignoramus. At the age of eleven he could not read, and when, at fourteen, he was sent to school, he made a complete failure in his studies, as he afterwards did in business. It is clear that Pestalozzi's method was only adapted to the earliest

years of school-life; and his biographer expressly says that older pupils who came to him for instruction went away disappointed. In short, his method, as modified and applied by his successors, has proved a useful auxiliary in early childhood to the regular system of education; but that is all that can be claimed for it. His love of children, however, and his ardent interest in the poor and ignorant, with his lifelong efforts for their improvement and elevation, are worthy of all praise. It is these noble qualities of the man that give the chief interest to his biography; and there is not a teacher anywhere that cannot learn something in this respect by a perusal of this work.

The Electric Motor and its Applications. By MARTIN and WETZLER. New York, W. J. Johnston. 4°. \$3.

THIS is a revised and enlarged edition of a work first published about two years ago, and reviewed in these columns at that time. While considerable space is given to the theoretical and historical views of the electric motor, the book is mainly devoted to its more modern development and application. The present work is in great part a reprint of the first edition, to which have been added nearly a hundred pages of new matter, thus giving a complete review of the subject treated down to the end of 1888. The new chapters contain a description of all the noteworthy motors and electric-railway systems introduced since the publication of the earlier edition, as well as a discussion of alternating-current and thermomagnetic motors. Thus the new portion of the book not only comprises instances in which electric power has advanced from the experimental stage to that of successful practice, but also casts a glance at the results which the future may be expected to yield. The book is worthy a place in the library of every electrician, and to the general reader it is not without interest.

Examination of Water for Sanitary and Technical Purposes. By HENRY LEFFMANN and WILLIAM BEAM, Philadelphia, Blakiston. \$1.25.

THIS is an admirable little manual of one hundred and six pages, giving in clear and concise language the most trustworthy and practicable processes for the examination of water. The soap-test for the determination of the hardness of water, which has been so long in use by chemists, has been abandoned by the authors as inaccurate, and in its place they have recommended the method devised by Hehner, in which sodium carbonate and sulphuric acid are employed. For the determination of nitrate and nitrites the calorimetric tests are advised to the exclusion of the more troublesome and uncertain processes heretofore in use. In order to have the advanced nomenclature and notation of the present time kept constantly in mind, a set of labels for the re-agents has been provided, and is furnished with the book. Among the special features of this volume are the chapters describing the action of water on lead, and the technical application to be deduced from an analysis of a given specimen of water, its action on boilers, etc.

The Bacteria in Asiatic Cholera. By E. KLEIN, M.D. London and New York, Macmillan. 16°. \$1.25.

THIS volume is a reprint of a series of articles published in the *Practitioner* in 1886 and 1887, together with a number of contributions which have since been made to the knowledge of the comma bacilli of Koch. Klein may be regarded as the most pronounced opponent of Koch's theory that the comma bacillus is the cause of Asiatic cholera. That he is, however, not the only one, is shown by the statement in the volume before us, that Baumgarten, Pettenkofer, and Enmerich in Germany; Roy, Sherrington, and Brown in England; and Shakspeare in America,—hold the same opinion as Klein. While denying the causal relation between the comma bacillus of Koch and *Cholera Asiatica*, Klein, nevertheless, recognizes its diagnostic importance. On this point he says he agrees to the proposition, that, if in any case of diarrhoea the choleraic comma bacilli can be shown both by the microscope and by culture-experiments to exist, then the suspicion that it may be a case of Asiatic cholera is quite justified: for if it should be found, that, in a locality which is in communication by sea or land with an infected country, one or more suspicious cases of diarrhoea had occurred, the demonstrations by culture-experiments of the

presence in the intestinal discharges of the choleraic comma bacilli would fully justify us in regarding such cases with grave suspicion as being probably, though not necessarily, choleraic. At all events, sanitary officers, for the sake of the public weal, would be justified in treating these cases as cases of cholera, and in taking measures of isolation and disinfection. It is impossible at the present time to decide between such men as Koch and Klein and their adherents. Each day new facts are being discovered, and views which seemed to rest on a firm foundation have had to be abandoned in the light of newly discovered evidence. Klein shows very plainly that many of Koch's earlier statements in reference to the presence or absence of the comma bacillus have already required great modifications. Fortunate it is that all are agreed, that, whether Koch's comma bacillus cause the Asiatic cholera or not, its presence is sufficient evidence of the existence of that disease to demand of sanitary officials the most rigid isolation of the suspicious case, and the most thorough disinfection of his clothing and surroundings.

First Book of Nature. By JAMES E. TALMAGE. Salt Lake City, Utah, Contributor Company.

THIS little book is designed to assist in the elementary study of the simplest objects of nature,—such as all people have more or less necessity of dealing with,—and as a help to mothers, and teachers in primary schools, will prove of great assistance. It deals with the simplest facts in the animal, vegetable, and mineral kingdoms, and such facts as every one ought to know. The ignorance of many of these simple facts on the part of many persons who are presumably educated is both lamentable and ridiculous. In a legal trial which occurred some time since, in which complaint was made that a crowing rooster was a nuisance, and kept in violation of an ordinance prohibiting the keeping of noisy animals in the city, it was maintained that an action could not lie, because a rooster was not an animal. Had those who held this opinion read this "First Book of Nature," such a blunder could not have been made.

AMONG THE PUBLISHERS.

"THE Voltaic Accumulator," an elementary treatise by Emile Reynier, translated from the French by J. A. Berly, C.E. (New York, E. & F. N. Spon), describes in a didactic manner the whole of the practical and scientific acquisitions made in the domain of the voltaic accumulator from Planté to our days. It brings together, summarizes, explains, and classifies the notions, theories, and inventions relating to secondary currents, and reviews the principal applications of the latter.

"Eight Hundred Miles in an Ambulance" is the title of a little volume of papers republished from *Lippincott's Magazine*, and describing the adventures of Mrs. Laura Winthrop Johnson on a journey across the Western plains with an army paymaster.

—Mr. B. P. Shillaber (Mrs. Partington) is writing his reminiscences of the last half-century.

—P. Blakiston, Son, & Co., medical and scientific publishers, booksellers, and importers, 1012 Walnut Street, Philadelphia, have just published the "Medical Directory of Philadelphia and Camden, 1889," containing lists of physicians of all schools of practice, dentists, druggists, veterinarians, and chemists, with information concerning medical societies, colleges, and associations, hospitals, asylums, charities, etc.; and "A Manual of Chemistry," for the use of medical students, by Brandreth Symonds, A.M., M.D., assistant physician Roosevelt Hospital, out-patient department, and attending physician Northwestern Dispensary, New York.

—Robert Carter & Brothers will publish, by arrangement with the author and English publisher, the autobiography of John G. Paton, missionary to the New Hebrides.

—John Wiley & Sons announce "Philosophy of the Steam-Engine Developed," by Professor Robert H. Thurston; "Composition, Digestibility, and Nutritive Value of Food," by Professor H. A. Mott; and "General Motions of the Atmosphere, Cyclones, Tornadoes, Water-Spouts, Hail-Stones, etc.," by Professor William Ferrel.

— *The American Garden* of New York has taken another step forward by the incorporation of its business under the title of "The Garden Publishing Company, Limited." The management goes on largely in the same hands, but with the more intimate connection of several able men, who really have had much to do in making *The American Garden* what it has become; and, with increased means, the editor expects to more rapidly improve the magazine, and increase the business in proper lines. The organization of the new company stands as follows: Lawson Valentine, president; Charles Barnard, vice-president; L. H. Bailey; John DeWolf, secretary; Edgar H. Libby, treasurer. Mr. Valentine is also president of the Christian Union Company; a prominent member of the great publishing-house of Houghton, Mifflin, & Co., owner of Houghton Farm; and president of the Lawson Valentine Company, makers of fine varnishes. Mr. Barnard is connected with The Century Company, author of that wonderfully successful

drama, "The County Fair," author of numerous successful books on technical subjects, and a practical horticulturist as well. Professor Bailey is head of the new horticultural department at Cornell University, and a thoroughly practical man of wide experience. Mr. DeWolf is a professional landscape-gardener, for several years head of the art department and assistant editor of *The American Garden*. Mr. Libby has been the editor and publisher for four years and a half, and has pushed the business with hard work and exceptional skill.

— The editorial management of the *North American Review* is at present in the hands of Mr. William H. Rideing.

— Macmillan & Co. will publish shortly an appendix to Grove's "Dictionary of Music and Musicians," which completes the fourth and concluding volume of the work. A full index to the work is in preparation, which will be published later in a separate volume.

Publications received at Editor's Office,
May 27-June 1.

- DAWSON, G. M. Report on an Exploration in the Yukon District, N. W. T., and Adjacent Northern Portion of British Columbia, 1887. Montreal, Dawson Bros. 277 p. 8°. 30 cents.
- EMERSON, R. W. The Fortune of the Republic and other American Addresses. (Riverside Literature Series, No. 42.) Boston and New York, Houghton, Mifflin, & Co. 109 p. 16°. 15 cents.
- GRIMES, J. S. Geonomy: Creation of the Continents by the Ocean Currents. And Kosmonomia: the Growth of Plants and the Cause of Gravitation. Philadelphia, Lippincott. 139 p. 16°. 50 cents.
- KELLOGG, M. M. Tullii Cicerois Brutus de Claris Oratoribus. Boston and London, Ginn. 296 p. 12°.
- KING, C. "Laramie;" or, The Queen of Bedlam. A Story of the Sioux War of 1876. Philadelphia, Lippincott. 277 p. 12°. \$2.
- SANBORN, J. W. Go to the Ant and learn Many Wonderful Things. Cincinnati, Cranston & Stow; New York, Hunt & Eaton. 119 p. 12°.
- THOMSON, J. Travels in the Atlas and Southern Morocco. New York, Longmans, Green, & Co. 488 p. 8°. \$3.
- VIGNOLES, O. J. Life of Charles Blacker Vignoles. London and New York, Longmans, Green, & Co. 407 p. 8°. \$5.

Old and Rare Books.

One Million Magazines. Back numbers, vols. and sets—old and new. Foreign and American. CATALOGUE UPON APPLICATION.
A. S. CLARK,
34 Park Row, New York City.

BACK NUMBERS and complete sets of leading Magazines. Rates low. AM. MAG. EXCHANGE, Schoharie, N. Y.

H. WILLIAMS,
Dealer in Old Magazines, Reviews, &c. Scientific periodicals a speciality. 39 Macdougall St., N. Y.

Readers of Science

Corresponding with or visiting Advertisers will confer a great favor by mentioning the paper.

Correspondence solicited with parties seeking publishers for scientific books.

N. D. C. HODGES,
Publisher of Science,
47 Lafayette Place,
New York.

IN PRESS FOR EARLY PUBLICATION.

GEOLOGY AT A GLANCE.

Ives Strata Map of the United States,

In which the Architecture of the Earth's Crust is Graphically Exhibited, Illustrating Fundamental Facts alike of

STRUCTURAL GEOLOGY AND PHYSICAL GEOGRAPHY.

The Strata Map is a device for the more efficient teaching of Physical Geography and Elementary Geology in Schools. It consists of a series of Superimposed Maps, of DIFFERENT COLORS, representing the several geological formations of the district, enclosed in a frame, the whole hinged to ad-

mit of examination in detail. By its means *superposition, denudation, and outcrop* of strata are graphically exhibited, with the phenomena of *escarpments, outliers, inliers, dip, strike, conformability, &c.*, and the Cards may be bent to show *synclinal or anticlinal* folds.

OPINIONS OF EMINENT GEOLOGISTS.

- Yale University, Professor James D. Dana, "Well fitted for the use of instruction in the science."
Professor Addison E. Verrill, "It will be of very great advantage in the teaching of geology."
Harvard University, Professor N. S. Shaler, "An extremely useful adjunct to our means of illustration."
Johns Hopkins University, President D. C. Gilman, "Wherever American geology is taught your map should be a part of the apparatus."
Pennsylvania University, Professor Geo. A. Koenig, "The map will be of special use in schools, which can only devote a short time to the study of Geology."
Michigan University, Professor Alexander Winchell, "It seems to me that the device will commend the study of Geology to many persons who might otherwise regard the subject as difficult and uninviting. The work prepared by Mr. Ives ought to be used extensively in American schools."
Cornell University, Professor H. Shaler Williams, "A valuable aid to teachers of geology as a means of graphically representing the grand facts of stratigraphy in the Eastern United States."
Columbia College, New York, Professor J. S. Newberry, "A valuable aid in teaching geology, giving as it does to the student a clear idea of the superposition of the different geological systems at a glance."
Dartmouth College, Hanover, N. H., Professor C. H. Hitchcock, "Am satisfied that its use will greatly assist students to understand the geological structure of the country."

- Academy of Natural Sciences of Philadelphia, Professor Angelo Heilprin, "The representation of Strata, as imposed one upon the other, by means of cardboard is certainly a good plan, for apart from rendering more intelligible the general expressions of the Map, it permits of ready alteration and the possibility of constantly bringing the map up to date, in other words to make it conform to more recent discoveries."
Boston Society of Natural History, Professor Alpheus Hyatt, "Your map representing superposition and the various phenomena of geological science, so far as the distribution of rocks on this continent is concerned, has greatly interested me. I think that in the hands of a good teacher it would prove an efficient and useful adjunct in the teaching of geology."
American Museum of Natural History, Professor R. P. Whitfield, "In the direction of a want long felt by Teachers of Geology and will undoubtedly be appreciated by them as well as by the student."
U. S. Geological Survey, Major J. W. Powell, Director, "After examination I am able to state that the work has been executed with care and fidelity, and I believe it will be a valuable aid to teachers."
New York State Survey, Professor James Hall, State Geologist, "I believe that maps constructed upon this method would be extremely useful in the hands of competent teachers."
Pennsylvania Survey, Professor J. P. Lesley, State Geologist, "A piece of new and useful apparatus for teaching Geology, by representing to the eye of the student the areas of superimposed formations. I cordially recommend it to teachers and students."
New Jersey Survey, Professor Geo. H. Cook, State Geologist, "It is very neatly done and must prove a great help to intelligent teaching and studying of Geological Science."

N. D. C. HODGES, 47 Lafayette Place, New York, N. Y.

—E. & F. N. Spon announce as in preparation "The Engineers' Sketch-Book of Mechanical Movements, Devices, Appliances, Contrivances, Details, etc.," by T. W. Barber; "Public Institutions; their Engineering, Sanitary, and other Appliances, with the Construction of Special Departments," by F. Colyer; "Practical Gold Mining," a comprehensive treatise on the origin and occurrence of gold-bearing gravels, rocks, and ores, and the methods by which the gold is extracted, by C. G. W. Lock; and "Egyptian Irrigation," by W. Willcocks.

—The Baker & Taylor Company announce for early publication, "The Drill-Master in German, based on Systematic Gradation and Steady Repetition," by Solomon Deutsch, Ph.D., author of "Letters for Self-Instruction in German," etc. This work the author claims to be an application of the principle of presenting but one difficulty at a time, and illustrating and explaining it so fully and by such numerous examples that it has ceased to be a difficulty before another step is taken. It is sought less to give grammatical instruction than to cause the language itself to be so learned that the student without a thought of grammar would never use it except in a grammatical manner. They also announce a "Genealogy of the Farnham Family," by J. M. W. Farnham.

—A. S. Barnes & Co. will publish at once Ex-United States Minister Theodore S. Fay's long-promised work, "The Three Germanies." Dr. Philip Schaff, who read the work in manuscript, says of it, "Few men have had better opportunities to study the history of Germany than Theodore S. Fay, who for twenty-five years occupied diplomatic positions in the service of the United States at Berlin, London, and Berne, and has been residing near Berlin since his retirement from public life. He was an eye-witness of the important events of 1848, 1866, and 1870. His personal experience and long observation give a fresh and life-like character to his interesting work on 'The Three Germanies,' especially the greater part of the second volume from the reign of King Frederick William III., to the death of Emperor Frederick III. in June, 1888."

—The Worthington Company have ready a large-paper edition (limited to 500 copies) of David M. Main's "Treasury of English Sonnets."

—Mrs. Humphry Ward has given up her visit to this country.

—An outcome of Professor J. P. Mahaffy's tour of Greece will be a book on the monasteries of that country.

—Margaret Deland's new novel will be entitled "Sidney Page." Though not dealing directly with theology, it will have a religious motive.

—The Duke of Argyll has written a new work, entitled "What is Truth?" in which the question is considered from a scientific as well as from a theological point of view.

—Marion Crawford's "With the Immortals" is being translated into French, and Rénan will contribute a preface. The French Academy has awarded to Mr. Crawford a prize of two hundred dollars for his two novels written by himself in French, and entitled "Zoroastre" and "Le Crucifix de Marzio."

—Mr. Joseph Thomson, the author of "Through Masai-Land," and as an African traveller second only to Stanley, has just written a book on his recent explorations, "Travels in the Atlas and Southern Morocco," which will be published immediately in New York by Longmans, Green, & Co. It will contain six maps and more than sixty illustrations.

—Alfred R. Conkling of New York, the nephew of Roscoe Conkling, generally known as Alderman Conkling, has about completed the work of collecting material for his life of his uncle, and has a portion of the book already written. He expects to have the entire work ready for the press in October. The publishers will be Charles L. Webster & Co.

—D. C. Heath & Co. have become the American publishers of the Isaac Pitman's shorthand books. They will shortly publish De Garmo's "Essentials of Method." The function of the book is to discover, through "an analysis of the mental activities involved in knowing, what are the essential elements of good method in teach-

ing." It is accompanied by practical illustrations showing "the application of the general laws of right method to all the branches of the common school curriculum."

—The Long Island Historical Society will soon print, for subscribers, about one hundred and fifty unpublished letters of Washington, from its manuscript collections, in a large and handsome octavo volume, entitled "George Washington and Mount Vernon." It will contain a portrait of Washington, not heretofore engraved, from an original painting by Charles Peale (1787), owned by the Rev. Mason Gallagher of Brooklyn; also a portrait of Betty Lewis, Washington's only sister. The historical introduction and annotations will be prepared by Mr. Moncure D. Conway, biographer of Edmund Randolph.

—L. Prang & Co. have published a little booklet containing illustrations in color of the mayflower and the golden-rod, with charming verses by Hopewell Goodwin, in which each flower sets forth its own merits to the choice for America's national flower. Its object is chiefly to decide which of the two is considered the most popular flower, and which therefore might be considered the national flower of America. To ascertain the respective popularity of these and our other American flowers, and thereby hasten, if possible, a solution of the question, the above little work is published. A postal-card accompanies each book, on which the purchaser is requested to fill out, with full address, his choice, and return it. The result, as it appears from time to time, will be published in the daily papers in different parts of the country, and on Jan. 1, 1890, L. Prang & Co. will mail to every voter the final decision.

—A. C. Armstrong & Son are preparing "The Complete Works of William Wordsworth." They are to be known as the "New Handy Volume Red Line Edition," and will be issued in eight volumes.

—George Brumder, 286 Water Street, Milwaukee, Wis., has just ready the first part of a work on "North American Birds." No efforts have been spared to make this one of the most excellent works on the subject. The colored plates are made after the original water-color paintings by Professor Robert Ridgway of the Smithsonian Institution, Professor A. Goering of Leipzig, and Gustav Muetzel of Berlin. The firm which produced these originals in a highly finished style, Ernst Kaufmann, in Lahr, Germany, and New York, is well known in art-circles for its speciality, chromo-work. Mr. Nehrling is an original writer, not simply a compiler. He has observed the life of our birds in the woods of Wisconsin, where he was born, in the prairies of Illinois, in Florida, Texas, Missouri, and many other States. The work will be in twelve parts, of forty to forty-eight pages reading-matter, and three colored plates, and will be completed in the fall of 1890.

—Swan, Sonnenschein, & Co. have published the collection of early letters of Jane Welsh Carlyle, edited by Mr. D. G. Ritchie. In addition to those of Mrs. Carlyle, the volume includes eleven unpublished letters of Carlyle, dealing chiefly with his studies in connection with the projected history of German literature and his "Cromwell."

—Ginn & Co. announce in the College Series of Latin Authors, Cicero's "Brutus," edited by Martin Kellogg. In the "Brutus" which was composed in 46 B.C., and purports to be a conversation with Atticus and Brutus, Cicero traces the development of oratory among the Romans down to his own time, with critical notices of about two hundred speakers. The long catalogue is relieved of dryness by the dialogue form, the freedom of digression, and by Cicero's fresh and teeming style. Professor Kellogg has edited the work especially for early college-reading. The introduction touches upon points of interest to those to whom Cicero is no stranger, and contains a full conspectus. The notes deal with the subject-matter, historical relations, and diction of the dialogue rather than with the commonplaces of grammar. Parallel passages are freely given, especially from Cicero's other rhetorical works and from Quintilian. The book is believed to be a substantial addition to the apparatus for the intelligent study of one of the most characteristic and valuable works in Latin literature.

— *The Political Science Quarterly* for June, 1889, opens with a study of "Municipal Government in Great Britain," by Albert Shaw of the *Minneapolis Tribune*. The article is based on prolonged and direct investigation, and goes behind the legal institutions to show their actual working. J. Hampden Dougherty describes the movements of the last forty years for amendment of the New York State Constitution, discussing especially the various projects for the reform of our city government. Frederick W. Whitridge writes on "Rotation in Office," advocating a repeal of the four years' law, which he regards as the basis of the spoils system. E. P. Cheyney of Pennsylvania University criticises from a social and economic point of view the decisions of the American courts on conspiracy and boycott cases. Professor J. W. Jenks of Knox College, Illinois, gives a history of the whiskey trust, and its effect on prices. The number contains the usual reviews, by specialists, of recent economic and political literature, and a record of political events continued from the last record published in the *New Princeton Review*.

LETTERS TO THE EDITOR.

A New Chemical Experiment

(which it would not be well to repeat very often).

LATELY, in my lecture to my class on phosphorus and its compounds, I made hydric phosphide in the usual way, by boiling phosphorus in a strong solution of potassic hydrate. That the class might see that phosphorus melted in an alkaline solution would remain in a liquid state after the solution had cooled, I left the pint flask containing the solution *in statu quo* until the next recitation. I had done the same repeatedly, but never before leaving it for so long a time as on this occasion, — from Friday until Monday. On entering the lecture-room on Monday morning, I observed the flask, and remarked, "All right, the phosphorus is still in a liquid condition;" and, mechanically taking up the flask, I gave it a slight shake, when it immediately exploded with a loud report, shattering the flask into minute fragments, and scattering its contents in every direction; the phosphorus, fortunately, instantly solidifying. So, save a slight cut on the wrist, I escaped without injury. It would be interesting to know if any one else ever experienced a like explosion, and the probable explanation of the explosion. A possible explanation is, that the gas had by adhesion become condensed around the phosphorus as the solution cooled, and that, the slight shake overcoming the adhesion, there was a rapid evolution of the gas. It would not be advisable to repeat the experiment without the face and hands and clothing were well protected. In this connection I would urge that it would be well if chemists, on noticing any like dangerous phenomena not laid down in the text-books, would publish the fact for the benefit of the brotherhood, to prevent serious accidents.

I well remember how near I came meeting with a serious accident from the explosion of a large piece of sodium thrown upon water; the old text-books, written when the price of sodium was as great as for potassium, thus rendering the former too expensive to use except in very small quantities, stating that sodium would not take fire like potassium. The explosion of sodium has resulted in the devising of that most brilliant of all chemical experiments, the ice-volcano.

It is not, perhaps, generally known that iodide of nitrogen, if left standing in aqua ammonia for twenty-four hours, will explode while wet; and even when freshly prepared, if partially dried and then scattered over the surface of a tank of water, it will for hours after

repeatedly explode on slightly agitating the water. Many years ago I devised a method of exploding with safety a mixture of phosphorus and potassic chlorate, which I give for the benefit of the young experimenter. Place powdered potassic chlorate (no more than will cover a nickel, if exploded within doors) upon a board, and wet it with a solution of phosphorus in carbon disulphide (an inch of phosphorus will dissolve in an ounce and a half of carbon disulphide in a few minutes). In from five to ten minutes, or as soon as the mixture is dry, touch it with a long pole, or even stamp heavily on the floor, and a loud explosion will result.

A quantity sufficient to cover a dollar out in the air will shatter a thick plank, and make considerable of a hole in the ground. I have never experimented with large quantities, but presume that rocks might be thus shattered.

J. R. EATON.

Liberty, Mo., June 1.

Relative Frequency of Letters and Combinations.

IN a recent number of the *Phonographic World* a correspondent asks, "In English composition, (1) what is the relative frequency of the occurrence of the various letters of the alphabet; (2) in what proportion does each letter precede and follow each other letter of the alphabet; and (3) what syllables occur the most?"

In answer to the first question, it may be stated that in a font of type for printer's use, as supplied by type-founders, the different letters are usually supplied in about the following proportion: *e*, 1,200; *t*, 900; *i*, 865; *a*, 850; *n*, *o*, and *s*, 800 each; *h*, 640; *r*, 620; *f*, 450; *d*, 440; *l*, 400; *u*, 340; *c* and *m*, 300 each; *w* and *y*, 200 each; *g* and *z*, 170 each; *b*, 160; *v*, 120; *k*, 80; *g*, 50; *j* and *x*, 40 each; *p*, 20.

Some years ago I undertook to analyze 10,000 words of everyday English, from the editorial columns of twenty leading dailies, 500 words from each, selected from articles in which no undue prominence appeared to be given to any particular word. My object was to ascertain what combinations of two or more letters occurred with greatest frequency. My eyesight failed before my task was half completed; but the result of my labors, as far as they went, may be of interest in connection with the foregoing questions. In 3,500 words, as far as my analysis extended, I found that two-letter combinations occurred as follows: —

Times.		Times.		Times.		Times.	
th.....	605	is.....	175	as.....	111	me.....	89
in.....	314	at.....	173	it.....	111	ma.....	88
an.....	312	or.....	153	al.....	110	co.....	85
of.....	236	es.....	128	he.....	94	be.....	77
re.....	232	se.....	121	ha.....	93	le.....	77
er.....	227	ed.....	120	ve.....	92	pr.....	72
on.....	205	to.....	120	de.....	91	la.....	71
en.....	186	ar.....	117	ou.....	90	ll.....	70

This, of course, does not answer the questions asked, but the material furnished may be of some assistance to the inquirer, should he wish to pursue the subject further.

It may be added, that in the number of words mentioned, the word *the* occurred 250 times; *of*, 180 times; *and*, 144 times; *to*, 79 times; and *in*, 74 times. 918 words occurred only once each, 163 twice, and 65 three times. The three-letter combination *the* (in *there*, *them*, etc., as well as alone) occurred 400 times; *and*, 172 times; *ing*, 114 times.

A very suggestive point to type-writer manufacturers and inventors is the fact that in all these words the letter *s* occurred but 8 times, while *th* occurred 605 times, and *the*, 400 times.

H. J. T.

New York, June 4.

INDUSTRIAL NOTES.

A New Photographic Lens.

THE Messrs. Beck have just turned out of their factory, and Morris Earle & Co., 1016 Chestnut Street, Philadelphia, have received from them, a new combination of their excellent lenses whereby one Iris diaphragm tube is adapted to carry three different sets of lenses, so that a photographer can take 4 × 5, 4½ × 6½, and 5 × 8 views by means of adapting the three sets of lenses. Messrs. Earle & Co. have also recently received a new four-inch

rectilinear, with Iris diaphragm, from the same firm, — the smallest lens they have ever turned out for photographers' purposes. This is meant to take lantern-slide negatives particularly, and is one of the finest lenses ever received from them.

A Beautiful Portfolio of Paintings in Water Colors.

The manufacturers of the well-known Scott's emulsion of cod-liver-oil are issuing the most beautiful portfolio of eight artistic studies (birds and flowers) that has ever come under our notice. This work is worth at least two dollars, but Messrs. Scott & Bowne, with their usual enterprise, have made arrangements

whereby they can supply a copy by mail to any one who will write to them, enclosing twenty-five cents in stamps or post-office order. This is a chance seldom offered, and all lovers of art should avail themselves of it. Mention this paper, and address Scott & Bowne, 132 and 134 South Fifth Avenue, New York.

Magnesium Flash-Lamp.

A lamp for burning pure magnesium has been invented by Mr. E. M. Pine, one of the most successful of amateur photographers, whose flash-light photos were awarded the first prize at the Pittsburgh exhibition in 1888. Recognizing the danger attending the use of the various explosive compounds heretofore used for illuminating, Mr. Pine has succeeded in inventing a lamp for burning



pure magnesium, as shown in the accompanying illustration, after much experimenting, and believes his lamp, for brilliancy, rapidity, and simplicity, as has been pronounced by professional photographers who have tested it, to be a most complete flash-lamp. Its construction is said to insure perfect combustion; and, as magnesium is non-explosive, absolute safety is assured. The lamp is so portable that it can be easily carried in the pocket, weighing about four ounces.

Paris Exposition and International Congress of Electricians.

James W. Queen & Co., Philadelphia, call the attention of college professors and others interested in scientific work, who are intending to visit the Paris Exposition this summer, to the following facts. They have most excellent representatives in Paris who

have had the experience of many years in the selection and purchasing of scientific apparatus of every description for college use. In consequence of this, it has occurred to them that it might be a convenience to their patrons when in Paris to be supplied with letters of introduction to these agents.

By means of such letters, those professors who intend purchasing apparatus will have the assistance of competent persons, who are well acquainted with all the prominent makers, their apparatus, and prices. Thus much valuable time may be saved that might otherwise be spent in hunting up dealers and making bargains with them, — a rather unsatisfactory operation, especially to those not thoroughly conversant with the French language. Furthermore, it is often a great inconvenience and annoyance, after apparatus may have been purchased satisfactorily, to attend to the details of shipping and passing through the United States Custom-House "free of duty." James W. Queen & Co. will be pleased to relieve purchasers entirely of all this care, so that they need have nothing to do but select the apparatus.

Another advantage of this arrangement is, that there need be no expenditure on the part of colleges at the time of ordering apparatus. Apparatus ordered through these agents will be forwarded in the firm's weekly shipments as soon as a few pieces are ready, thus saving much time.

Those among the electrical fraternity who expect to attend the International Congress of Electricians will please note that they as well as college professors will find it to their advantage to advise with the firm's agents before buying apparatus for their companies or for themselves personally. Messrs. Queen & Co. do not wish professors or electricians, if they avail themselves of the offer of letters of introduction, to feel under obligations to purchase any thing. They will also be pleased to furnish letters to their agents in England, Germany, and Switzerland, if desired.

ONE LANGUAGE FOR THE WHOLE WORLD.

WORLD-ENGLISH :

THE UNIVERSAL LANGUAGE. 25 CENTS.

EVERY one has heard of the butcher who, after a long search for his knife, at last found it in his mouth: so speakers of English have been seeking for a universal language, when, lo! it is in their mouths. The intelligibility of English words has been obscured by a dense mist of letters. This is now dispersed by A. Melville Bell, who has already won a world-wide reputation through his invention of "Visible Speech," the great boon to deaf-mutes. Professor Bell calls this new discovery of his "World-English," and the result is a language which cannot fail to meet with acceptance, and at once supersede the supposed necessity for "Volapuk," or any other artificial language. No language could be invented for international use that would surpass English in grammatical simplicity, and in general fitness to become the tongue of the world. It is already the mother-tongue of increasing millions in both hemispheres, and some knowledge of the language is demanded by all educated populations on the globe. Social and commercial necessities require that the acquisition of this knowledge shall be facilitated, and it is believed that Professor Bell's invention has removed the last impediment to English becoming the universal language, for which vague desires have long been entertained, although hitherto only futile efforts have been made.

Ex-President Andrew D. White, of Cornell University, says: "I believe that the highest interests of Christian civilization and of humanity would be served by its adoption. China and Japan would be made English-speaking people within fifty years, and so brought within the range of Christianizing and civilizing ideas, in the largest sense. All existing missionary work is trivial as compared with this. For your system would throw wide open those vast countries, as, indeed, all the countries of the world, to the whole current of English and American thought."

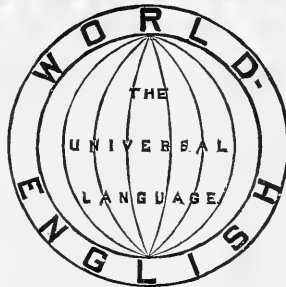

For Diffusion of English throughout the World
AS
THE UNIVERSAL LANGUAGE
This "Hand-Book of World-English" is the Complete, Simple,
and Efficient Medium.
FOREIGNERS

Will Acquire, by Means of this Hand-Book, a
PERFECT PRONUNCIATION OF ENGLISH.
FOR Primary School Pupils and Illiterate Adults
World-English is a Royal Road to Reading.
To Teachers of English and Modern Languages
This Hand-Book will be of Primary Importance
as a Phonetic Directory.

DEFECTS OF SPEECH

Will be Readily Corrected by Means of the Articulative Directions in this Hand-Book.

HAND-BOOK OF WORLD-ENGLISH,

25 CENTS.

The plan of this little book is altogether new. Letters and sounds are so associated, in all the exercises, that from the mere knowledge of letters a learner cannot fail to pronounce words with certainty. English reading will thus be easily acquired, whether by natives or foreigners, children or adults.

The general resemblance of World-English to Literary English is such that any reader of the latter decipheres the former at sight, or, at most, after a few minutes' study of the new letters. A like result may be anticipated for those who shall learn to read from World-English. They will transfer their power of reading to the literary form of the language, almost without effort. The orthographic aspect of words will, besides, be so fixed in the eye, by contrast, that spelling will be remembered as — what it really is — a pictorial association with words.

No special training is required to qualify teachers for using this book. The subject can even be successfully introduced in the kindergarten and the nursery. This phonetic mode of initiation in reading cannot be too strongly urged on the attention of School Boards on both sides of the Atlantic.

The ordinary orthography of each word is interlined with the World-English version throughout the Exercises and Readings.

So set down, our tongue is the best for the world to unite upon. — *Boston Traveller*.

The idea of Mr. Bell has much to recommend it, and the presentation is charmingly clear. — *American, Phila.*

The result is a language which cannot fail to meet with acceptance. — *Boston Traveller*.

Has the merit of great ingenuity. — *Railway Age*.
His treatise, as a study of English orthoepy, condenses the result of much thought and experience in small compass. — *The Critic*.

World-English deserves the careful consideration of all serious scholars. — *Modern Language Notes*.

World-English is the English language unburdened of its chaotic spelling. — *Popular Science Monthly*.
We commend it to the attention of teachers. — *Ottawa Globe*.

"World-English" and "Hand-Book of World-English" can be had of all booksellers, or will be sent for 50 cents, post free, by the publisher.

N. D. C. HODGES, 47 Lafayette Place, New York.

GUARANTY INVESTMENT COMPANY

CAPITAL \$250,000.

Offices: Atchison, Kan. 191 Broadway, New York. 222 Walnut St., Phila.

Hon. ALBERT H. HORTON (Chief Justice, Kansas Supreme Court), Topeka, Kan., Pres't.

7%₀ Guaranteed Farm Mortgages 7%₀

The Guaranty Investment Company makes loans upon fertile farms in the choicest portions of Kansas and Nebraska and has adopted the policy of sending a Committee of its Investors each year to examine its loans and methods of business.

The Committee this year consisted of PROF. A. H. BERLIN, Principal of the High School Montrose, Pa., and MAJ. THEODORE L. POOLE, Ex-U. S. Pension Agent, Syracuse, N. Y. Both of these gentlemen are persons of the highest character and have the confidence of the Communities in which they reside.

The Committee has recently returned and has made a very interesting Report upon the general development of Kansas and Nebraska as well as the business of the Company. The Company will be glad to send this Report to any address.

The following names are taken from the long list of Investors in our Mortgages:

(See if Some Friend of Yours is not in the List.)

William A. Caldwell, 59 Liberty St., N.Y.
 Palmer Cox, 658 Broadway, N.Y.
 Rev. Jos. H. Rylance, D.D., 11 Livingston Place, N.Y.
 Rev. Brady E. Backus, D.D., 360 West 28th St., N.Y.
 Rev. R. M. Sommerville, 126 West 43th St., N.Y.
 Dr. Robert A. Murray, 215 West 23d St., N.Y.
 Dr. James P. Tuttle, 156 West 41st St., N.Y.
 H. Edwards Kowland, 218 Fulton St., N.Y.
 Irving H. Tift, Esq., 271 Broadway, N.Y.
 Prof. D. G. Eaton, 33 Pineapple St., Brooklyn, N.Y.
 Dr. E. P. Thwing, 156 St. Marks Ave., Brooklyn, N.Y.
 Dr. C. C. Miles, Greenport, N.Y.
 John V. N. Bergen, Port Jefferson, N.Y.
 Benj. W. Stilwell, Yonkers, N.Y.

R. C. Coleman, Goshen, N.Y.
 Mrs. Samuel Carlisle, Newburg, N.Y.
 Dr. C. C. Bartholomew, Ogdensburg, N.Y.
 Rev. Nelson Millard, D.D., Rochester, N.Y.
 Rev. Horace G. Hinsdale, D.D., Princeton, N.J.
 Dr. Charles M. Howe, Passaic, N.J.
 George A. Skinner, 5 Railroad Place, Newark, N.J.
 Dr. Edwin M. Howe, 83 Halsey St., Newark, N.J.
 Dr. H. G. Buckingham, Clayton, N.J.
 Dr. Martin Cole, Jr., Hainesville, N.J.
 Mortgage Trust Co. of Pa., Philadelphia, Pa.
 Miss Mary Miller, 1220 Spruce St., Philadelphia, Pa.
 Henry D. Biddle, 312½ Walnut St., Philadelphia, Pa.

Dr. Calvin C. Halsey, Montrose, Pa.
 Rev. William Baldwin, Great Bend, Pa.
 Gen. William Lilly, Mauch Chunk, Pa.
 Second Nat. Bank, Mauch Chunk, Pa.
 Enos E. Thatcher, West Chester, Pa.
 Mrs. Townsend Poore, Scranton, Pa.
 Rev. Burdett Hart, D.D., New Haven, Conn.
 Dr. Frank H. Wheeler, New Haven, Conn.
 Charles R. Christy, Stamford, Conn.
 Mrs. Catharine P. Fuller, Woodmont, Conn.
 Miss Jessie Henderson, Lenox, Mass.
 Dr. M. J. Halloran, Worcester, Mass.
 Albert Walker, Bennington, Vt.

Address for Report and Monthly Bulletin

HENRY A. RILEY, General Eastern Manager, 191 Broadway, N.Y.

Specialties in Silks.

We shall put on sale, this week, one line of Black Faile Francaise, 20 inches wide, at 75 cents per yard; and a very large purchase of Plain Colored Gros Grains, in over 30 desirable shades, at 75 cents per yard.

These goods are of exceptional value, and calculated to give excellent satisfaction.

Samples sent on request.

JAMES McCREERY & CO.

BROADWAY AND ELEVENTH STREET, NEW YORK.

Schools.

CONNECTICUT, NEW HAVEN, MRS. CADY'S SCHOOL FOR YOUNG LADIES. Prepares for Smith and Wellesley, and admits to Vassar by Certificate. Circulars. Early application necessary.

NEW JERSEY, PLAINFIELD. THE CHESTNUTS.—Parents with daughters to educate, or orphan girls with companion, may find a comfortable home, with school instruction by applying to Miss E. E. Kenyon.

The Mutual Life Insurance Company OF NEW YORK.

RICHARD A. McCURDY, PRESIDENT.

ASSETS - - - \$126,082,153 56

The Largest and best Life Insurance Company in the World.
 The New Business of the Mutual Life Insurance Company in 1888 Exceeded \$103,000,000.

Its Business shows the Greatest Comparative Gain made by any Company during the past year including

A gain in assets of.....	\$ 7,275,301 68
A gain in income of.....	3,096,010 06
A gain in new premiums of.....	2,333,406 00
A gain in surplus of.....	1,645,022 11
A gain in new business of.....	33,756,792 85
A gain of risks in force.....	54,496,251 85

The Mutual Life Insurance Company

Has Paid to Policy-holders since Organization \$272,481,839 82.

Original, Simple, Natural, Suggestive, Comprehensive, Educational and helpful entirely apart from the memory phase of the subject. JOURNAL of EDUCATION

Memory SHEDD'S NATURAL METHOD, PRACTICAL, SCIENTIFIC.

Entirely different from any other memory method. Thoroughly taught by correspondence.

ENDORSED BY LEADING EDUCATORS.

DESCRIPTIVE PAMPHLET FREE. MEMORY SCHOOL, 4 W. 14th STREET NEW YORK CITY

IMPROVING THE MEMORY PICK

and facilitating the acquirement of knowledge by lectures and correspondence. Classes forming. "MEMORY and its Doctors," from Simonides to "Loisette," mailed for 25 cents (New Edition).

DR. PICK, 24 Union Square, N. Y. City.

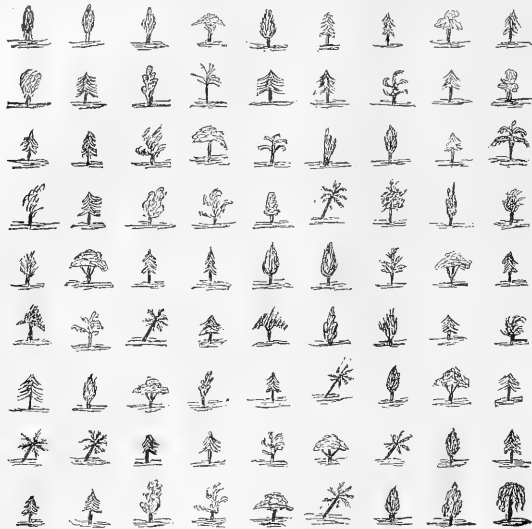

Can any reader of Science solve the following puzzle ?

A man having 81 trees to cut, arranged as above, cuts nine each day for nine days without cutting on any one day more than one tree from any line, vertical, horizontal, or diagonal.

Any one who will have the following blank filled out by a responsible Newsdealer, and mailed to us, will be allowed a three months' subscription to *Science*.

N. D. C. HODGES,
47 LAFAYETTE PLACE, NEW YORK.

1889.

To the _____ News Company.

You may add to my regular order five copies of SCIENCE each week (returnable).

SCIENCE CLUBBING RATES.

	10% DISCOUNT.	Yearly Subscription.	With Science.	With Swiss Cross.
We will allow the above discount to any subscriber to <i>Science</i> or <i>The Swiss Cross</i> who will send us an order for periodicals exceeding \$10, counting each at its full price.				
Agricultural Science.....	\$2.50	\$5.30	\$4.50	
American Agriculturist.....	1.50	4.30	2.50	
American Analyst.....	1.00	4.25	2.25	
American Architect and Building News.....				
Imperial edition.....	10.00	12.80	11.00	
Gelatine ".....	7.00	9.80	8.00	
Regular ".....	6.00	8.80	7.00	
American Garden.....	1.00	4.25	2.25	
American Journal of Phylology.....	3.00	6.25	4.25	
American Machinist.....	2.50	5.30	4.50	
American Naturalist.....	4.00	7.50	5.50	
Andover Review.....	4.00	6.80	5.00	
Atlantic.....	3.00	6.80	4.00	
Babyhood.....	1.50	4.30	2.50	
Babyland.....	.50	3.75	1.75	
Bradstreet's.....	5.00	7.80	6.00	
Brain.....	3.00	6.30	4.00	
Building (weekly).....	6.00	8.80	7.00	
Carpentry and Building.....	1.00	4.25	2.25	
Century Magazine.....	4.00	6.80	5.00	
Chautauquan, The.....	4.00	7.80	5.25	
Christian Union, The.....	3.00	5.80	4.00	
Christian Weekly, Illustrated.....	2.50	5.30	3.50	
Cosmopolitan, The.....	2.00	4.80	3.00	
Critic.....	3.00	5.80	4.00	
Eclectic Magazine.....	5.00	7.80	6.00	
Edinburgh Review.....	4.00	6.80	5.00	
Electrical World.....	3.00	5.80	4.00	
Electrician and Electrical Engineer.....	3.00	5.80	4.00	
Electrical Review.....	5.00	8.20	4.00	
Engineering and Mining Journal.....	4.00	6.80	5.00	
English Illustrated Magazine.....	1.75	4.55	2.75	
Forest and Stream.....	4.00	6.80	5.00	
Forum, The.....	5.00	7.80	6.00	
Godey's Lady's Book.....	2.00	4.80	3.00	
Harper's Bazar.....	4.00	6.80	5.00	
Harper's Magazine.....	4.00	6.80	5.00	
Harper's Weekly.....	4.00	6.80	5.00	
Harper's Young People.....	2.00	4.80	3.00	
Health and Home.....	1.00	4.25	2.25	
Herald of Health.....	1.00	4.25	2.25	
Illustrated London News (Amer. reprint).....	4.00	6.80	5.00	
Independent, The.....	3.00	5.80	4.00	
Inter Ocean, The.....	1.00	4.25	2.25	
Iron Age (weekly).....	4.00	6.80	5.00	
Journal of Phylology (Eng.).....	2.50	5.30	3.50	
Journal of Speculative Philosophy (begins with Jan. No.).....	3.00	5.80	4.00	
Judge.....	12.00	14.80	13.00	
L'Art.....	5.00	7.80	6.00	
Life.....	3.00	5.80	4.00	
Lippincott's Magazine.....	4.00	6.80	5.00	
Little Men and Women.....	1.00	4.25	2.25	
London Quarterly.....	4.00	6.80	5.00	
Macmillan's Magazine.....	3.00	5.80	4.00	
Magazine of American History.....	5.00	7.80	6.00	
Medical and Surgical Journal.....	2.00	4.80	3.00	
Mechanical Engineer.....	1.00	4.25	2.25	
Metal Worker.....	1.00	4.25	2.25	
Microscope, The.....	2.00	4.80	3.00	
Nature.....	6.00	8.80	7.00	
New Princeton Review.....	3.00	5.80	4.00	
North American Review.....	5.00	7.80	6.00	
Outing.....	3.00	5.80	4.00	
Overland Monthly.....	4.00	6.80	5.00	
Pansy.....	1.00	4.25	2.25	
Political Science Quarterly.....	3.00	5.80	4.00	
Popular Science Monthly.....	5.00	7.80	6.00	
Popular Science News.....	1.00	4.25	2.25	
Portfolio, The.....	7.50	10.30	8.50	
Practitioner.....	3.50	6.30	4.50	
Public Opinion.....	3.00	5.80	4.00	
Puck.....	5.00	7.80	6.00	
Puck (German).....	5.00	7.80	6.00	
Quarterly Review (London).....	4.00	6.80	5.00	
Queries.....	1.00	4.25	2.25	
Registered News.....	2.00	4.80	3.00	
St. Nicholas.....	3.00	5.80	4.00	
School Journal.....	2.50	5.30	3.50	
Scientific American.....	3.00	5.80	4.00	
Architect and Builders' edition.....	2.50	5.30	3.50	
Scribner's Magazine.....	3.00	5.80	4.00	
Southern Cultivator.....	1.50	4.30	2.50	
Springfield Republican (weekly).....	1.00	4.25	2.25	
Sunday School Times.....	2.00	4.80	3.00	
Teachers' Institute.....	1.25	4.05	2.25	
Texas Sitings.....	1.00	6.80	5.00	
Trained Nurse.....	1.50	4.30	2.50	
Treasure-Trove.....	1.00	4.25	2.25	
Truth Seeker, The.....	3.00	5.80	4.00	
Wide Awake.....	2.40	5.20	3.40	
Young Folks' Journal.....	1.00	4.25	2.25	

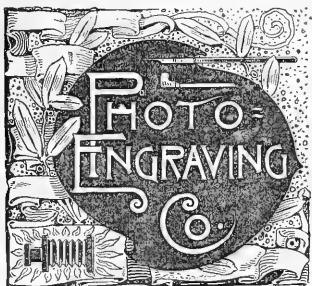

JOHN HASTINGS = PRES.
A-R-MART = Gen. Manager.
JOS. TRIPP = V. Pres.

ENGRAVING FOR ALL ILLUSTRATIVE AND ADVERTISING PURPOSES

BRANCH AT 728 CHESTNUT ST. PHILADELPHIA, PA.

67-71 PARK PLACE, NEW YORK.

N. D. C. HODGES,
47 Lafayette Place,
New York.

C. & C. ELECTRIC MOTOR COMPANY.

Electric Motors
 FOR
**Arc and Incandescent Cir-
 cuits, Most Economical
 Motor on the
 Market.**
Regulation Perfect.
**Motors Designed for all
 Power Purposes.**

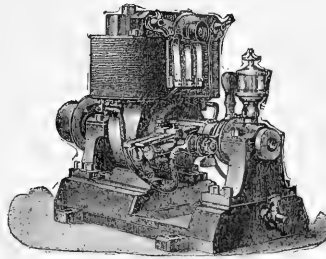

OFFICE and MANUFACTORY:
 402 and 404 Greenwich Street, New
 York City.

New England Office, 19 Pearl St.; Boston.

Philadelphia Office, 301 Arch St.

Western Office, 139-141 Adams Street,
 Chicago.

Southern Office, 25 Carondelet Street,
 New Orleans.

"The Week, one of the ablest papers on the con-
 tinent."—*Descriptive America.*

ENLARGED AND IMPROVED.
THE WEEK:
*A Canadian Journal of Politics, Literature, Science
 and Arts.*

PUBLISHED EVERY FRIDAY.
 \$3.00 per Year. \$1.00 for Four Months.

THE WEEK has entered on its SIXTH year of pub-
 lication, greatly enlarged and improved in every
 respect, rendering it still more worthy the cordial
 support of every one interested in the maintenance
 of a first-class literary journal.

The independence in politics and criticism which
 has characterized THE WEEK ever since its first
 issue will be rigidly maintained; and unceasing ef-
 forts will be made to improve its literary character
 and increase its value and attractiveness as a jour-
 nal for the cultured home. Many new and able
 writers are now, or have promised to become, con-
 tributors to its columns, and the constant aim of the
 Publisher will be to make THE WEEK fully equal
 to the best literary journals in Britain and the United
 States.

As heretofore, PROF. GOLDWIN SMITH will, from
 time to time, contribute articles. London, Paris,
 Washington and Montreal letters from accomplished
 correspondents will appear as regular intervals.
 Special Ottawa Letters will appear during the ses-
 sions of Parliament.

THE WEEK in its enlarged form will be the same
 size as "Harpers' Weekly," and the largest paper
 of its class on the continent.

SEND FOR FREE SAMPLE COPY.

C. BLACKETT ROBINSON, Publisher,
 5 Jordan St., Toronto.

**A NEW MAGAZINE—THE SWISS
 CROSS**
 Devoted to spreading the love of
 nature among the people. Edited
 by HARLAN H. BALLARD, President of the Agassiz Asso-
 ciation, and succeeding *Naturalist*, the official mag-
 zine of that body. \$1.50 a year. Sample copy 10 cents. or 25
 cents for trial subscription for 3 months.
 N. D. C. HODGES, PUBLISHER,
 Mention this magazine 47 Lafayette Place, New York.

Wants.

A YOUNG MAN can have lucrative engage-
 ment, not only a fixed salary, but accord-
 ing to his work accomplished in travelling for
 SCIENCE. A personal interview invited.
 N. D. C. HODGES,
 47 Lafayette Place, New York.

MECHANICIAN.—An optician and maker
 of instruments of precision of experience
 would be glad of a position where his skill
 would be valued in connection with some higher
 educational institution. Address G. J., care of
 SCIENCE, 47 Lafayette Place, New York.

Scientific Apparatus.

J. GRUNOW,
 621 Sixth Avenue, New York.
 Established 1832.
 MAKER OF
 Microscope Stands,
 Oil Immersion Object-
 ives and Abbe Con-
 densers for Bacterial
 and Histological work,
 of Objectives, Camera
 Lucida and other ac-
 cessory apparatus.

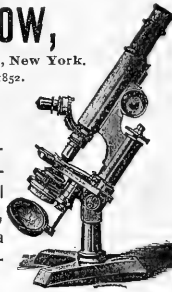

**IMPROVED OIL LIGHT
 MAGIC LANTERNS.**
 Also Lime and Electric Light Apparatus, and
 mechanical, plain, and fine colored views.
J. B. COLT & CO., Manufacturers,
 No. 16 BEEKMAN STREET, NEW YORK.

MORRIS EARLE & CO.
 SUCCESSORS TO
R. & J. BECK,
 1016 Chestnut Street, Phila.
 Microscopes and all
 Accessories and Ap-
 paratus. Photograph-
 ical and Photo-Micro-
 graphic Apparatus and
 Outfits.
 Spectacles, Eye
 Glasses, Opera and
 Marine Glasses, etc.
 Illustrated Price List
 mailed free to any ad-
 dress. Mention SCIENCE
 in corresponding with us.



E. & H. T. ANTHONY & CO.
 591 Broadway, N.Y.
 Manufacturers and Importers of
PHOTOGRAPHIC INSTRUMENTS,
 Apparatus and Supplies of every
 description. Sole proprietors of
 the Patent Detective, Fairy Nov-
 el, and Bicycle Cameras, and the
 Celebrated Stanley Dry Plates.
 All the latest novelties in great variety, from \$5.00 upward.
 Send for Catalogue or call and examine. More
 than 40 years established in this line of business.



Readers of Science
 Corresponding with or visiting Advertisers,
 will confer a great favor by mentioning this paper.

*A few of the earlier bound volumes of "Science" (slightly
 "shop-worn") for sale at \$1.25 per volume. Mailed post-paid
 within the United States on receipt of price.*
N. D. C. HODGES, 47 Lafayette Place, New York.

ELECTRICAL TESTING BUREAU,
 Johns Hopkins University, Baltimore, Md.
 Resistance Coils and Boxes Compared.
 Am meters and Volt meters calibrated.
 Condensers standardized.
 Primary and Secondary Batteries Tested.
 Efficiency of Dynamos and Motors Deter-
 mined.
 Insulation of Cables and Wires Tested.
 Etc., Etc.
 Circulars describing Methods Used, Prices,
 Etc., sent on Application.
 Address as above.

A TEMPORARY BINDER
 for Science is now ready, and will be mailed
 postpaid on receipt of price.
 Half Morocco - 75 cents.
 This binder is strong, durable and
 elegant, has gilt side-title, and allows
 the opening of the pages perfectly
 flat. Any number can be taken out
 or replaced without disturbing the
 others, and the papers are not mutil-
 ated for subsequent permanent bind-
 ing. Filed in this binder, Science is
 always convenient for reference.
N. D. C. HODGES,
 47 Lafayette Place, New York.



Sprague Electric Railway and Motor Company.

Lightest Weight Consistent with
Highest Efficiency.

SIMPLE IN CONSTRUCTION.

Not Liable to get out of Order.

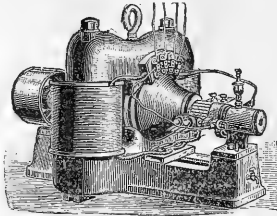

Bearings Self Oiling.

NON-SPARKING IN OPERATION.

Commutator Wear Reduced
to a Minimum.

16th and 18th BROAD STREET, NEW YORK.

CALIGRAPH

MEDAL AWARDED!

GREATEST SPEED ON RECORD!!

126 words per minute, errors excluded.

T. W. Osborne, winner of international contest at Toronto, wrote on the Caligraph Writing Machine 630 words in five minutes, thus gaining for the Caligraph the championship of the world.

30,000
in
Daily Use.

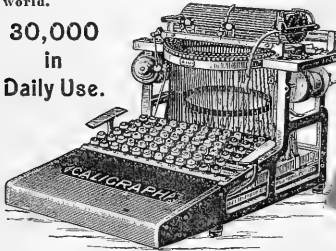

For full and correct account of above test, address
THE AMERICAN WRITING MACHINE CO.,
HARTFORD, CONN.

New York Branch, 237 Broadway.

SOMETHING NEW
THE PATENT
ADJUSTABLE
BRUSH.

LIQUID GLUE
ALWAYS
READY FOR USE

**THE STRONGEST
GLUE
IN THE WORLD.**
2 GOLD MEDALS
LONDON 1883
RUSSIA 1883
St. Petersburg 1889

Used by thousands of first-class mechanics and by such manufacturers as Pullman Palace Car Co., Mason & Hamlin Organ and Piano Co., &c., &c.

Repairs Everything.
Its success has brought a lot of imitations copying us in every way possible. Remember that THE ONLY GENUINE LePage's Liquid Glue is manufactured solely by the
RUSSIA CEMENT CO.
GLOUCESTER, MASS.

Send 10c. and dealers' card who doesn't keep it in stock, for sample.

Patent Pocket Can. No waste.



KIMBALL'S STRAIGHT CUT CIGARETTES.

Unsurpassed in quality.
Used by the world of refined taste.
Highest award at Brussels, 1888.
The finest smoking mixtures are of our manufacture.
Fifteen First Prize Medals.
WM. S. KIMBALL & CO.,
Rochester, N. Y.

REMINGTON STANDARD TYPEWRITER

WON

Gold and Silver Medals

FOR

CHAMPIONSHIP OF THE WORLD.

At Toronto, in open contest, Aug. 13, 1888.

151 Words per Minute, Without an Error.



The above is an authentic record made by Mr. Frank E. McGurrin, at Detroit, on Jan. 21, 1889, on a memorized sentence, thus beating all previous records of correct work, by 30 words per minute and placing the "Remington" still further beyond reach of competition. Photographic copies of certified work furnished on application. WYCKOFF, SEAMANS & BENEDICT, 327 Broadway, N. Y.

PARIS EXPOSITION.

The Cheque Bank issues Cheques, either singly or put up in Books, for the special use of VISITORS to the PARIS EXPOSITION, who can cash the same at upwards of seventy Banking Houses, scattered in different parts of Paris, without

any assistance. Matter can be addressed to them, 2, 500, Boulevard des Capucines, 4 Place de l'Opera, opposite the Grand Hotel, where English is spoken.

Every Cheque issued by the Cheque Bank is EQUAL TO GOLD. Cheque Bank Notes are, for the Bank's Capital, Guarantee Fund and Customers' Balances are invested in British Government Securities, or held in Cash in the Bank of England, and can be cashed in every town in Europe without charge.

For Handbook containing list of 2, 500 Banking Houses who cash the cheques, free of charge, apply to

CHEQUE BANK, Limited,
Capital, £100,000. Guarantee Fund, £27,000.
Trustees, The Right Honorable John Bright, M.P.,
The Right Honorable Karl Beauchamp.
NO. 2 WALL STREET, NEW YORK.

Visitors to Europe and Paris Exposition should carry a book containing Cheque Bank Cheques, which are absolutely safe and cheaper than Letters of Credit, and much more convenient; are payable on presentation without charge at 5,500 Banking Houses and 250 of the principal Hotels in Europe.

FOOD ADULTERATION

And its Detection. With photomicrographic plates and a bibliographical appendix. By J. P. Battershall, 328 pages, 8vo, cloth. Price, \$3.50. Circulars and Catalogues on application. E. & F. N. SPON,
12 Cortlandt St., New York.

Readers of Science

Corresponding with or visiting Advertisers will confer a great favor by mentioning the paper.



DROP

IN THE
PRICE
OF

GRAVITY

DROP

ANNUNCIATORS.

DON'T FORGET THE
DUST-PROOF BELLS.

HAZARD & STANLEY,
32 Frankfort Street, N. Y.

THE GREAT AMERICAN TEA COMPANY

GOOD NEWS TO LADIES.

Greatest inducements ever offered. Now's your time to get up orders for our celebrated
Teas and Coffees, and secure a beautiful Gold Band or Moss Rose China Tea Set, Dinner Set, or Band Moss Rose Toilet Set, Watch, Brass Lamp, or Webster's Dictionary. For full particulars address
THE GREAT AMERICAN TEA CO.,
P. O. Box 239, 81 and 83 Vesey St., New York.

529

93713
JUN 15

SCIENCE

[Entered at the Post-Office of New York, N.Y., as Second-Class Matter.]

A WEEKLY NEWSPAPER OF ALL THE ARTS AND SCIENCES.

SEVENTH YEAR.
VOL. XIII. No. 332.

NEW YORK, JUNE 14, 1889.

SINGLE COPIES, TEN CENTS.
\$3.50 PER YEAR, IN ADVANCE.

WESTINGHOUSE ALTERNATING-CURRENT DYNAMO.

The Westinghouse dynamo for generating an alternating current is shown in the accompanying illustration. It is apparent at a glance that it is different in principle of construction from the ordinary direct-current machine. The field is composed of a series of radial pole-pieces of alternate polarity, the cores of which are cast solid with the casing or body of the machine. The field-coils

zontal plane through the shaft. The armature may be removed and replaced in similar manner.

The general design of the dynamo is symmetrical, and of a character calculated to give the greatest rigidity in its structure. Oil is fed from the cups to the bearings, and allowed to work freely into the drip-pan, and thence into the tank in the base, whence it may be drawn off at the stop-cock, strained, and returned to the oil-cups, thus permitting thorough lubrication without waste of oil.

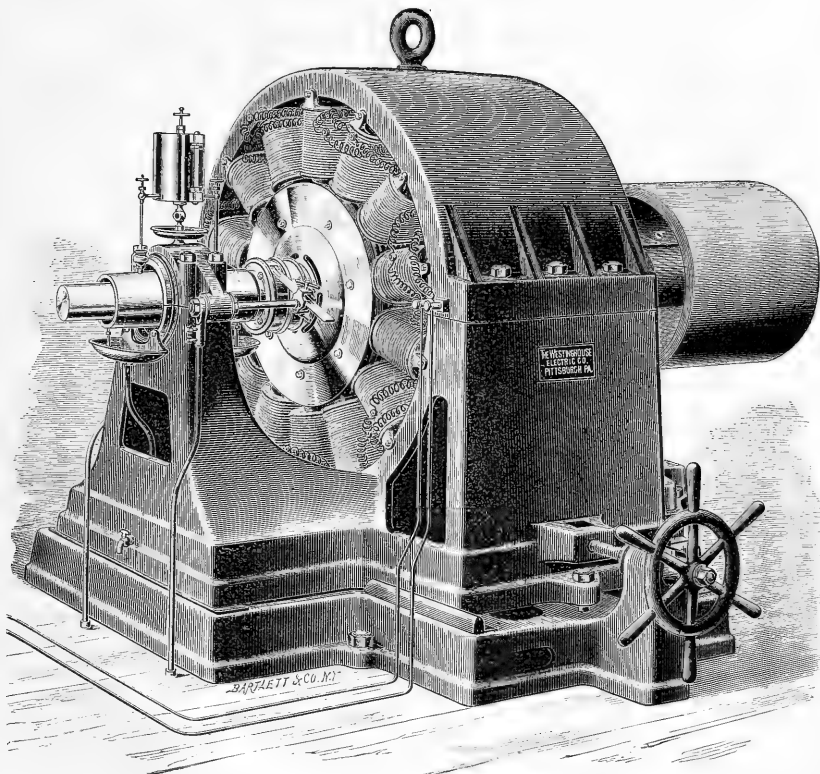

THE WESTINGHOUSE 1500-LIGHT ALTERNATING-CURRENT DYNAMO.

are a series of independent bobbins, which are first wound on shells, then slipped over the pole-pieces, and held in place by bolts. These bobbins, being supplied with a feeble current from the exciter, are subject to no natural deterioration, and are not liable to accident. They can only be damaged by carelessness; and, in case one should be so damaged, it may be easily removed and replaced, as the whole structure of the dynamo parts along a hori-

The illustration shows the side of the dynamo which carries the collecting-ring; the other side has a bearing similar to the one shown, beyond which is an overhung pulley made of compressed strawboard, which is found to be an excellent material for the purpose. The machine rests upon a cast-iron base, and is adjustable by means of a belt-tightener. The dynamo may be run in either direction or placed either way around on the base.

The Westinghouse Company at present manufacture five sizes of these dynamos, having capacities ranging from five hundred to five thousand 16-candle-power lights. The machine shown in the cut is the No. 2 dynamo, having a capacity of fifteen hundred lights.

The field-coils in these machines are supplied with current from a separate exciter, which is simply a small direct-current machine. The exciter may be driven by an independent engine, or it may, if desired, be attached to the shaft of the dynamo, in which case the dynamo is said to be self-exciting.

The armature of this dynamo is a structure of great simplicity. The body is of laminated iron plates, freely perforated for ventilating purposes. A single layer of wire is wound in flat coils back and forth across the face of the armature, parallel with the shaft, being held in place by stops on the ends of the armature. Mica and other insulation is provided, and the whole is wrapped with binding-wire. A ventilator is attached to each end of the armature, drawing a strong current of air through, thus insuring a sufficient degree of coolness. These armatures are uniformly wound to deliver a current of a thousand volts, a higher voltage than this for special circuits being obtained when necessary by means of a special converter. The absence of a commutator will be noticed in the illustration, its place being taken by two plain collecting-rings without breaks of any kind. Narrow collectors rest upon these rings, taking off the current as it is generated. With these collecting-rings it is obvious that the adjustment of the collectors is a matter of indifference, as no sparking can occur under any circumstance, there being no interruption of the current. The matter of dust or more or less oil has no effect, the whole device resolving itself into a detail of great simplicity.

GEOLOGICAL SURVEY OF NEW JERSEY.

THE work of this survey has been steadily prosecuted during the past year. In the annual report for 1887 it was stated that the Topographic and Magnetic Surveys of the State were completed, and that the reports upon these would be prepared and printed as rapidly as possible. This work is done, and the first volume of the final report of the Geological Survey of New Jersey is being distributed. It is an octavo volume of 450 pages, and contains a report on the Geodetic Survey by Professor Edward A. Bowser; on the Topographic and Magnetic Surveys, by C. C. Vermeule, C.E.; and on the climate of the State, by Professor John C. Smock. It also contains two maps of the State on a scale of five miles to an inch, — one showing its civil divisions; and the other, its elevations, mountains, ridges, valleys, and plains, together with its rivers and its drainage areas.

The work now preparing for publication as the second volume of the final report will contain a full catalogue of the minerals found in the State, with their localities; a catalogue of all the plants growing in the State, with notes of their occurrence and localities; and also catalogues of its vertebrate and invertebrate animals. Appendices to these catalogues will give some practical and economic particulars regarding them. Most of the work of preparing these catalogues is already done.

So much attention has been given in former reports to the study and description of the geological structure of the rocks of the State, that the work still to be done is mainly in combining and systematically arranging the materials which have been collected by various persons who have made New Jersey a study in former years. This is especially the case with the marl and clay formations in the middle of the State, and the limestones, slates, and sandstones in the north and north-western portions. There are some obscure and difficult points of structure in the red sandstone and the gneissic rocks; but it is thought that important progress has been made in clearing up these difficulties, and that the volume on structural geology can be prepared as soon as that above mentioned is out of the way, and that one on the economical geology can then properly complete the series.

The prompt publication and liberal distribution of the results of the State surveys have continued to meet the approval of the citizens, and to supply suggestive and needed information. The expenses of printing, mailing, and expressage are large; but the

returns in the development and wealth of the State abundantly justify the expenditure. The whole system of artesian well-boring was started at the direct suggestion of the survey, and it has brought inestimable sanitary and pecuniary benefits to the whole Atlantic coast, and has been of great service throughout the State. The description of the location and structure of our fire and potters' clays, and its publication, have caused the development of some of the best clay properties in the country, and have made public the immense stores of the best plastic and refractory materials in the immediate vicinity of the great manufactories and markets of the continent. The preparation and publication of the topographic maps, in advance of those of any other State, have tended to draw attention to the peculiar advantages of New Jersey in its location, its varied surface, its healthful seaside and mountain resorts, its water-supply, and its unequalled means of travel and communication. The maps are studied by engineers for projected improvements, by citizens seeking homes in the country, by land-owners who desire to improve or open their properties, as well as by intelligent and inquiring citizens of all kinds who are interested in the development and prosperity of the State. The publication of the condition of the mines, quarries, lime-production, marls, drained lands, water-supplies, and other matters of general interest, is continually inciting to new enterprises and the investment of capital; and the notes in regard to soils and the means for their improvement are helping to develop agriculture, and to greatly increase its products.

The public supply of pure and wholesome water to the people of the cities, towns, and villages, is of growing importance; and it needs to be kept before those who should reap the benefits of it. That there are abundant supplies of the best of water to be found in New Jersey, has been pointed out in several of the annual reports. Perhaps that of 1876 contained the most of detail. A bare repetition of some of the points may help to give a more definite idea of the magnitude and importance of the supply, as well as to keep the subject prominently in view.

From many years' observations it was shown that the annual rainfall varied in different years from about 30 inches in the driest years to about 60 inches in the wettest years, and that the average rainfall in all northern New Jersey was $44\frac{2}{3}$ inches per year. Observations upon the amount of water to be collected from the Croton watershed show that 60 per cent of the rainfall runs off in the streams. For purposes of safe calculation, however, it was assumed that only 40 per cent of the minimum rainfall should be depended upon: 40 per cent of 30 inches is 12 inches. From a square foot of surface, then, a cubic foot of water can be saved every year, or $7\frac{1}{2}$ gallons. From an acre, 326,700 gallons can be collected per year, or nearly 900 gallons per day. From a square mile there can be collected 209,088,000 gallons per year, or daily 572,844 gallons.

The watershed of the Passaic River above Little Falls is 750 square miles, being made up of the drainage areas of the following-named streams: Ramapo River, 148 square miles; Wanoque River, 108; Pequannac River, 82; Rockaway River, 165; Whippany River, 59; Passaic River, 188; total area of the Passaic and its branches, 750 square miles. Greenwood lake, with a drainage area of 32 square miles, is included in the Wanoque area. Lake Hopatcong, with a drainage area of 27 square miles, naturally found an outlet by the Musconetcong River into the Delaware; but, by the dam across its outlet, its surface has been raised so as to find an outlet by the Morris Canal into the watershed of the Passaic. The total area to be drawn from is, then, 777 square miles. This area can be depended upon to supply 500,000,000 gallons of water daily. At Little Falls, all this water is in one stream, at an elevation of 158 feet above mean tide; and it is only 16 miles from the centre of Newark, and 22 miles from the centre of Jersey City, or only about half the distance from which the Croton water is carried to New York. By going a few miles farther up the streams, most of the water could be collected at an elevation of 250 feet, or high enough to supply all of those cities by gravity.

The quality of this water is unquestionable in purity. It is mostly gathered from a country which is mountainous, mostly in forest, and likely to remain so for a long time to come. As a substitute

for the filthy water supplied to almost half the people of the State, it is of incalculable value, and there should be no delay in securing its health-giving benefits.

The artesian wells bored at various points on the Atlantic coast between Sandy Hook and Cape May continue to yield a supply of good and wholesome water, and some very satisfactory ones have been sunk along the Delaware.

THE MEDBERY UNDERGROUND SYSTEM.

We have to record this time another instance of the moving in cycles of human progress. As the first water-pipes for distributing water through towns were made of wood, to be afterwards made of iron and iron and cement, so now an inventor has produced a wooden pipe, not necessarily for use in conveying water, but more especially for use as a conduit for electric conductors. This pipe is made from long wood fibres, separated, washed free from saps and gums, and then moulded while in a pulpy state into the requisite size and shape, being subjected to great hydraulic pressure. After this it is treated and hardened by a chemical process, that, it is believed, renders it impervious to moisture, acids, or gas. The piping looks not unlike iron, but is, of course, much lighter, and is made in sections which can be joined by threads, like iron pipes, with a sleeve coupling. The pipes can be made continuous, thus preventing gases or moisture coming in contact with the enclosed wires. Each conduit is divided into four or more compartments,

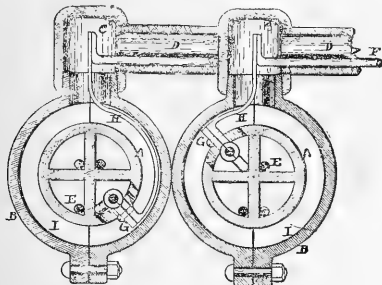

FIGS. 1 AND 2.—THE MEDBERY UNDERGROUND SYSTEM.

as shown in the illustrations; and the wires occupy separate ducts, which precludes the possibility of cross-circuits. The question of insulating wires is one of considerable importance, and the expenditure is necessarily very great; but in this conduit, by reason of the high insulating power of the material, expensive insulation of the wires is avoided.

Another noteworthy feature of this system is the method of distributing to houses and street-lamps. Usually it is necessary to make provision for this when laying the conduit, which is necessarily very expensive; but by this system side taps and connections can be as easily made at any time after the conduit is laid, and without serious expense, as will be explained from the accompanying illustrations, Figs. 1 and 2.

When desiring to make connection with the main line, the conduit is exposed at any point, and an opening is cut in it in any preferred manner. It is usually drilled. The wire is then lifted from its resting-place in the conduit, through the hole in the conduit; and the two parts of the metallic clamp *G*, being first separated, are put over the wire, and firmly attached thereto by means of a screw. The clamp has a chamber into which a suitable metal or solder is melted or fused, making a perfect contact and permanent joint. The two sides of the casing or connecting box (which, it will be seen, has a recess or hollow interior) may be filled with suitable insulating-cement while in a plastic state, and they are then placed about the conduit in such a manner that the extension of the clamp *H* projects through the neck of the casing, as shown in the cut. The bolts are then inserted in the lips of distributing-duct *B*, and screwed up. The cap *C* is then applied, and forced firmly down upon the tapering neck of the casing, after

being properly cemented. The branch wire is then connected with the extension from the clamp *H*, and, when it has been passed through the first length of the branch conduit *F*, the branch conduit is screwed into the threaded hole in the side of the cap *C*, or, preferably, cemented into place. The branch line can thus be extended as far as may be desired. Thus far in the process, connection has been made with one wire only, either the negative or the positive wire, but of course the connection with the other wire will be made in a similar manner.

The system as above outlined is being introduced by the American Indurated Fibre Company of Mechanicsville, N.Y., from whom further information may be obtained. It may be mentioned that satisfactory practical work with it has been done by the Bell Telephone Company of Philadelphia, the Pennsylvania Railroad Company, and other parties.

EDIBLE MUSHROOMS OF THE UNITED STATES.

FOR several years past the division of microscopy of the United States Department of Agriculture has been in receipt of numerous letters from regular correspondents and others, from which it appears that in various localities, representing almost every section and climate of the Union, there are found large quantities of edible mushrooms and other allied fungi; few of which, however, are utilized, owing to the inability of the great majority of the people to distinguish the edible species from the poisonous ones. To ob-

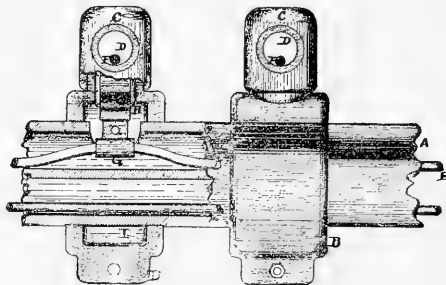

tain some clear and trustworthy criteria by which to make this essential distinction has been the object of the various communications received; and in view of the highly nutritious properties of this class of esculents, and of the great possible value of their aggregate product as indicated by the vast quantities produced in countries where attention is given to their cultivation, the importance of a satisfactory answer to these inquiries will be readily appreciated. This answer is given in a little pamphlet on twelve edible mushrooms of the United States, illustrated with twelve colored types, by Thomas Taylor, M.D., microscopist of the Department of Agriculture, Washington, D.C.

Rollrausch and Siegel, who claim to have made exhaustive investigations into the food-values of mushrooms, state that "many species deserve to be placed beside meat as sources of nitrogenous nutriment;" and their analysis, if correct, fully bears out the statement. They find, in 100 parts of dried *Morchella esculenta*, 35.18 per cent of protine; in *Helvella esculenta*, 26.31 per cent of protine, from 46 to 49 per cent of potassium salts and phosphoric acid, 2.3 per cent of fatty matter, and a considerable quantity of sugar. The *Boletus edulis* they represent as containing in 100 parts of the dried substance 22.82 per cent of protine. The nitrogenous values of different foods, as compared with the mushroom, are stated as follows: "protine substances calculated for 100 parts of bread, 8.03; of oatmeal, 9.74; of barley-bread, 6.39; of leguminous fruits, 27.05; of potatoes, 4.85; of mushrooms, 33.0." A much larger proportion of the various kinds of mushrooms are edible than is generally supposed, but a prejudice has grown up concerning them in this country which it will take some time to eradicate. Notwithstanding the occurrence of occasional fatal ac-

cidents through the inadvertent eating of poisonous species, fungi are largely consumed, both by savage and civilized man, in all parts of the world; and, while they contribute so considerable a portion of the food-product of the world, we may be sure their value will not be permanently overlooked in the United States, especially when we consider our large accessions of population from countries in which the mushroom is a familiar and much-prized edible.

In France mushrooms form a very large article of consumption, and are widely cultivated. Mushroom-beds are cultivated in caves, frequently miles in extent. A cave at Mery is mentioned as containing, in 1867, twenty-one miles of beds, and producing not less than three thousand pounds daily. Another at Frepillon contains sixteen miles of beds. The catacombs and quarries of Paris and vicinity, and the caves of Moulin de la Roche, Sous Bicetre, and Bagneux, produce immense quantities of mushrooms. They are all under government supervision, and are regularly inspected, like the mines.

The mushroom which is cultivated in these quarries and caves, almost to the exclusion of all others, is the "Snow-Ball" (*Agaricus arvensis*). The truffle is held in high esteem, and is largely exported. In 1872 the quantity of truffles exported from France was valued at over 3,000,000 francs; in 1879, at nearly 10,000,000 francs. Immense quantities of the *Agaricus deliciosus* are sold in the Marseilles markets. The *Fistulina hepatica* is also in great demand, and many other varieties appear from time to time in the markets throughout France. The natives of Australia use largely a truffle which attains a weight of more than two pounds, and is known under the name of "native bread." The Chinese, who are noted for the care bestowed on their esculent vegetation, consume large quantities of edible fungi, importing largely from Japan and Tahiti. The trade in edible fungi from Tahiti to China commenced about the year 1866; in 1868 only seventy tons were shipped; in 1873 one hundred and thirty-five tons were exported to China; and in 1874 one hundred and fifty-two tons were exported.

The value of mushrooms imported by Shanghai from Tahiti in 1872 was 107,000 taels; and in 1873, 138,800 taels (the tael is worth about six shillings sterling). The fungus shipped, *Exidia auricula Indæ* is said to be very rich in fungine and nitrogen. It is a very bulky freight: ten tons will occupy the room of thirty tons ordinary freight.

A very laudable practice of the Chinese Government alluded to in an English journal, and which might perhaps be advantageously adopted in this country, is the publishing, for annual gratuitous distribution, of numerous treatises describing the different herbs which can be utilized in whole or in part for food-purposes. One of these treatises is called the "Anti-Famine Herbal," and consists of six volumes, containing descriptions, with illustrations, of over four hundred plants which can be used as food. These volumes are of inestimable value in districts where the ravages of insects, drought, etc., have destroyed the grain and rice crops, and famine is imminent. For some years past New Zealand has exported large quantities of an edible fungus to San Francisco and Hong Kong for the use of the Celestials. A full account of this industry may be obtained from the United States consular reports. The gathering and drying of the fungus gives profitable employment to large numbers of colonial children, as well as to the Maoris. The species grows abundantly in the wooded regions of New Zealand, and when dry is worth from fourpence to fivepence a pound. The Chinese, who are singularly free from prejudice in the matter of food, use it, as they do the edible swallow's nest, as a chief ingredient in their favorite soup. They also employ it as a medicine, and, stranger still, for making a valuable dye for silk. Another remarkable edible fungus of New Zealand is the *Sphaeria Robertsi*, which grows out of the body of a large caterpillar, practically converting the latter into vegetable substance. The caterpillar lives under ground, and the fungus springs upwards through the soil till it reaches a height of eight or ten inches. It is eaten by the Maoris, who employ it also, when burned, as a coloring-matter.

The Japanese grow several species of edible fungi in logs of decaying wood in a manner peculiar to themselves; and, aside from the home consumption, they in one year exported to China mushrooms to the value of \$60,000. In 1879 mushrooms were exported

from Japan to the value of 243,440 yens. The yen is equal to 99 $\frac{7}{10}$ cents. Among the north-eastern tribes of Asia, fungi are largely used as food. One species, when pounded, forms their snuff; while another, the *Fly Agaric*, which is utilized in Europe as a fly-killer, and is regarded as one of the most poisonous forms, is used by them as a substitute for ardent spirits, one large specimen being sufficient "to produce a pleasant intoxication for a whole day." In many parts of Europe fungi are a favorite food, being eaten fresh, and also preserved in vinegar for winter use. For pickling purposes, all kinds, it is said, are gathered, the vinegar being supposed to neutralize the alkaline poison of the noxious species. The common mushroom, the morel, and the truffle, are, however, the favorite edible fungi. In Italy the value of the mushroom as an article of diet has long been understood and appreciated. Pliny, Galen, and Dioscorides mention various esculent species, notably varieties of the truffle, the boletus, and the puff-ball. At Rome it has been the custom of the government to appoint inspectors to examine all the mushrooms brought into market, and to reject such as are poisonous or worthless, which are thrown into the Tiber. It was required also that no mushrooms should be hawked about the streets, but that all should be sent to the central depot for inspection.

The yearly average of the taxed mushrooms sold (all over ten pounds being taxed) in the city of Rome alone, for the past decade, has been estimated at between sixty thousand and eighty thousand pounds weight. Large quantities of mushrooms are consumed in Germany, Hungary, Russia, and Austria, and in the last country a list is published, by authority, of those mushrooms which, upon official examination, may be sold. Darwin speaks of Terra del Fuego as the only country where cryptogamic plants form a staple article of food. A bright yellow fungus allied to *Bulgarin*, forms, with shell-fish, the staple food of the Fuegians. In England the common meadow mushroom, *Agaricus campestris*, is quite well known, and used to a considerable extent among the people, but there is not that general knowledge of and use of other species which obtains on the Continent. Much has been done of late years by the Rev. M. J. Berkeley, Dr. Curtis, Dr. C. D. Badham, Dr. M. C. Cooke, Worthington G. Smith, Professor Charles Peck, and others, to disseminate general knowledge on this subject. That America is no less rich in the quantity and variety of esculent fungi is readily seen by the fact that one hundred and eleven species of edible fungi have been described by the Rev. Dr. Curtis, State botanist of North Carolina, as indigenous to that State alone, and late investigations show that nearly all the species common to the countries of continental Europe are found in different localities in the United States. Dr. J. J. Brown of Sheboygan, Wis., writes that edible mushrooms are found in his neighborhood in great abundance.

Many methods of cultivating the common meadow mushroom have been presented by different growers, but all agree as to the value of the general methods in practice. Nearly every farm and nursery affords the conditions necessary to cultivate the ordinary field-mushrooms; such as sheltered sheds, stables, and small hot-beds for winter cultivation, and melon-patches, cucumber-pits, etc., for summer culture.

Mushroom spawn in "bricks" can be easily obtained from the seedsmen. Natural or virgin spawn, which is considered by many experienced growers as preferable to the artificial, can be obtained in most places where horses are kept. It is found in half-decomposed manure-heaps, generally where horse droppings have accumulated under cover. It is readily distinguished by its white filamentous character and by its mushroom odor. When dried, it can be kept for years.

Mushroom-beds are easily formed on the floors of sheds by carrying in the fresh stable-dung, adding to it about one-fourth of good loam, mixing both together, pressing firmly down, and letting the mass remain about two weeks untouched. By this time the temperature will be on the decline; and when it falls anywhere between 50° and 60° F., break the spawn bricks into pieces two inches square, and plant twelve inches apart, three inches below the surface. By means of any suitable instrument, beat the mass down firmly, then add three inches of good soil, and beat again.

For culinary purposes, mushrooms should generally be allowed a

growth of about six weeks, and when gathered should be carefully cut off with a knife, not broken.

It is recommended that mushroom-beds should not be finally earthed until the spawn is seen beginning to spread its white filaments through the mass; and should it fail to do this in eight or ten days after spawning, the conditions being favorable, it is better to insert fresh spawn or to remake the bed, adding fresh materials if it be found to fail from being too cold. The temperature of the beds at spawning-time should not exceed 80° F.: 70° F. is considered the most suitable regular temperature. It is advisable not to put the spawn at any uniform depth, but so that while one piece of it may be at a depth of six inches, or nearly so, others may touch the surface. This allows the spawn to vegetate at a depth and temperature most congenial to it. Mushrooms may be cultivated in warm cellars, in boxes about four feet square by eighteen inches in depth, for family use.

MINERAL PRODUCTS OF THE UNITED STATES.

The sixth report on "The Mineral Resources of the United States," by David T. Day, chief of the division of mining statistics and technology, United States Geological Survey, is to be issued shortly. This report is for the calendar year 1888, and contains detailed statistics for this period, and also for preceding years, together with much descriptive and technical matter. The following are the totals of the production of the more important mineral substances in 1888:—

Metals.

Iron and Steel.—The principal statistics for 1888 were: domestic iron ore consumed, about 12,060,000 long tons; value at mines, \$28,944,000. This is an increase over 1887 in quantity of 760,000 tons, but a decrease in value of \$4,956,000. Imported iron ore consumed, 587,470 long tons; total iron ore consumed in 1888, about 12,650,000 long tons, or 150,000 tons more than in 1887. Pig-iron made in 1888, 6,489,738 long tons; value at furnace, \$107,000,000. This is an increase over 1887 of 72,590 tons in quantity, but a decrease of \$14,925,800 in value. Steel of all kinds produced in 1888, 2,899,440 long tons; value at works, \$89,000,000. This is a decrease from 1887 of 439,631 tons in quantity, and of \$14,811,000 in value. Total spot value of all iron and steel made in 1888, in the first stage of manufacture, excluding all duplications, \$145,000,000, a decrease of \$26,103,000 as compared with 1887. Limestone used as a flux in the manufacture of pig-iron in 1888, about 5,438,000 long tons; value at quarry, about \$2,719,000.

Gold and Silver.—According to the director of the mint, the gold product was 1,604,927 fine ounces, valued at \$33,175,000. This is about the same as in 1887, being an excess of only \$75,000. The silver product was 45,783,632 fine ounces, of the commercial value of about \$43,000,000, and of the coining value of \$59,195,000. This is an increase of 4,515,327 ounces over the product in 1887. In addition to the product of our own mines, some 10,000,000 ounces of silver were extracted in the United States from foreign ores and bullion.

Copper.—The total product, including the yield of imported ores, increased to 231,270,622 pounds, or 115,635 short tons, during 1888, which is 46,053,291 pounds more than the product of 1887. During the first quarter of 1889 the production was increasing at even a more rapid rate. The prices received by American producers averaged 15.5 cents per pound for Lake copper, 14.5 for Arizona, and 14 for other districts, making the total value \$33,833,954. Montana led in the production, making 97,897,968 pounds. Consumption was somewhat reduced by the high prices.

Lead.—The product increased to 180,555 short tons from 160,700 tons in 1887. The increase was due principally to the heavier receipts of lead in Mexican silver-lead ores from 15,000 tons in 1887 to over 27,000 tons in 1888. The average price in New York was 4.41 cents per pound. The production of white lead, chiefly from pig-lead, was 89,000 short tons, valued at \$10,680,000.

Zinc.—The erection of new works and the extension of old ones led to a further notable increase in the production of zinc in 1888. The additions to capacity were fairly uniformly distributed in the

West, East, and South. Production in 1888, 55,903 short tons, with a total value of \$5,500,855; in 1887, 50,340 tons, worth \$4,782,300. The production of zinc white in 1888, directly from ores, was 20,000 short tons, worth \$1,600,000.

Quicksilver.—The product was 33,250 flasks (of 7½ pounds each) from California, a decline in that State of 510 flasks from 1887, in spite of a very satisfactory price, which averaged \$42.50 per flask, making the total value \$1,413,125. No new valuable deposits were discovered in 1888, and without them it is not probable that the yield of quicksilver will increase.

Nickel.—The industry remains unchanged except for indications of further developments at Lovelock in Nevada, and Riddle in Oregon. The product includes 190,637 pounds of metallic nickel, valued at \$114,382 at 60 cents per pound, and 4,545 pounds, worth \$1,136, exported in ores and matte. Total value, \$115,518. The corresponding value in 1887 was \$133,200.

Cobalt Oxide.—The total product, including the contents of the exported ores and matte, was 12,266 pounds, worth \$18,441. In 1887 the total was 18,340 pounds, worth \$18,774, the lower rate of value in that year resulting from a larger proportion of exported nickel in matte and ore. The price of cobalt oxide remained at \$2 per pound.

Chromium.—The product declined from 3,000 tons in 1887 to 1,500 tons in 1888. The average price in San Francisco remained \$15 per ton. Increased operations are probable in 1889.

Manganese.—The product of manganese and manganiferous iron ores in the United States in 1888 was 239,460 tons, valued at \$876,215. Of this amount, some 25,500 tons would be classed as manganese ores; the remainder, as manganiferous iron ores. Of the manganiferous iron ores, 11,462 tons averaging 11 per cent of manganese, and 189,574 tons averaging 4 per cent of manganese, were from the Colby Mine, Michigan. In addition to the above, some 60,000 tons of argentiiferous manganese ores, valued at \$10 a ton, chiefly for the silver contained in them, were produced in the Rocky Mountain region.

Aluminum.—The past year was more promising than ever before for the production of cheap aluminum. The production of metallic aluminum as an industry distinct from the production of alloys began toward the close of the year, and 500 pounds had been made up to Dec. 31. The production of 3,000 pounds since then indicates that the industry may continue. The exact amount of alloys produced by the Cowles process has not been furnished, but was not markedly different from the product of 1887, when 18,000 pounds of aluminum contained in bronze and ferro-aluminum were produced. The price for metallic aluminum declined to as low as \$4.50 per pound for less favored brands.

Platinum.—Including the platinum and iridium separated from gold by the assay offices and that saved in placer gold-mining, the product was about 500 ounces, valued at \$2,000.

Fuels.

Coal.—The total production of all kinds of commercial coal in 1888 was 142,037,735 short tons (increase over 1887, 18,022,480 tons), valued at the mines at \$204,221,990 (increase, \$30,625,994). This may be divided into Pennsylvania anthracite, 43,922,897 short tons (increase, 4,416,642 short tons), or 39,216,872 long tons, including 38,145,718 long tons shipped by the railroads and canals and reported by their statistician, Mr. John H. Jones, and 1,071,154 long tons sold to the local trade at the mines (increase, 3,943,430 long tons), valued at \$85,649,649 (increase, \$6,284,405); all other coals, including bituminous, brown coal, lignite, small lots of anthracite produced in Colorado and Arkansas, and 4,000 tons of graphitic coal mined in Rhode Island, amounting in the aggregate to 98,114,838 short tons (increase, 13,605,838 tons), valued at \$118,572,341 (increase, \$24,341,589).

The colliery consumption at the individual mines varies from nothing to 8 per cent of the total output of the mines, being greatest at special Pennsylvania anthracite mines, and lowest at those bituminous mines where the coal-bed lies nearly horizontal, and where no steam-power or ventilating-furnaces are used. The averages for the different States vary from 2 to 6.4 per cent; the minimum average being in the Pennsylvania bituminous, and the maximum average being in the Pennsylvania anthracite region.

The total output of the mines, including colliery consumption, was Pennsylvania anthracite, 41,624,610 long tons (increase over 1887, 4,045,863 long tons), or 46,619,564 short tons (increase, 4,531,367 short tons); all other coals, 102,039,838 short tons (increase, 14,152,478 tons); making the total output of all coals from mines in the United States, exclusive of slack coal thrown on the dumps, 148,659,402 short tons (increase, 18,683,845 tons), valued as follows: anthracite, \$89,020,483 (increase, \$4,468,302); bituminous, \$122,497,341 (increase, \$24,492,685); total value, \$211,517,824 (increase, \$28,960,987). The above figures show a notable increase in 1888 over 1887 in the aggregate output and value of both anthracite and bituminous coal, although not as great an increase as occurred in 1887 over 1886 in the value of the anthracite, or in the total tonnage of the bituminous coal.

Coke.—The production of coke in the United States in 1888 was 8,527,560 tons, valued at about \$14,000,000. Pennsylvania produced by far the largest amount, the Connellsville region alone producing 4,955,553 tons; West Virginia, 528,533 tons; Alabama, 518,511 tons; Tennessee, 385,693 tons; and Virginia, 149,099 tons.

Petroleum.—The product of petroleum in the United States in 1888 was 27,346,018 barrels (of 42 gallons each), valued at about \$24,598,559. Of this amount, Pennsylvania produced 16,491,083 barrels; Ohio, 10,010,868 barrels; West Virginia, 119,448 barrels; California, 704,619 barrels; and other States, 20,000 barrels.

Natural Gas.—The amount of natural gas consumed is given in coal displacement; that is, the amount of coal displaced by the use of natural gas. It is estimated that the amount of coal displaced by natural gas in the United States in 1888 was 14,163,830 tons, valued at \$22,662,128. Of this amount, 12,543,830 tons were displaced in Pennsylvania, 750,000 tons in Ohio, and 660,000 tons in Indiana.

Structural Materials.

Building-Stone.—Direct returns from producers of the various kinds of building-stone show that there was but a small gain in value over the figures of 1887. The value of the stone produced in 1888 is \$25,500,000, or \$500,000 more than in the preceding year.

Brick and Tile.—Value, \$48,213,000. This figure represents only a small gain over 1887. This is due rather to increase in the number of manufacturing plants than to increased production at the older and more important sources of supply; in fact, many of the latter show a falling-off in production. Prices also were generally somewhat lower than in 1887.

Lime.—The production is estimated at 49,087,000 barrels, with an average value of 50 cents per barrel, making a total of \$24,543,500 as the value of the year's product. These figures are not largely in advance of those for 1887, and the gains are not so much the results of increased production in the leading lime regions as in localities of minor importance.

Cement.—The amount of cement produced in 1888 is less than for 1887, being 6,253,295 barrels for 1888, valued at 72.5 cents per barrel, making \$4,533,639 as the value of the year's product.

Abrasive Materials.

Buhrstones.—The product which is used for grinding cement, plaster, paints, feed, etc., comes from New York, Pennsylvania, and North Carolina, and is valued at \$150,000.

Grindstones.—Ohio and Michigan furnish practically all the sandstone from which grindstones are made. The product in 1888 increased slightly; 41,000 long tons, worth \$281,800, being produced, against 37,400, worth \$224,400, in 1887. The price varied from \$6.50 to \$10 per ton at the quarries before being finished into grindstones.

Corundum.—Production is limited to the old mines in North Carolina and Georgia: 589 short tons, valued at \$91,620, were produced in 1888 against 600 tons in 1887.

Oilstones and Whetstones.—The production of novaculite from Arkansas increased slightly, making the total, including Labrador oil-stone, etc., 1,500,000 pounds, valued at \$18,000 in the rough state.

Miscellaneous.

Precious Stones.—No systematic mining was carried on in search of gems in 1888; but in mining for other substances, and in chance discoveries, gems worth \$64,850 in the rough state, and gold quartz worth \$75,000, were found.

Phosphate Rock.—The production declined to 433,705 long tons, but the total value increased slightly to \$1,951,673 on account of better prices. The trade in manufactured fertilizers was very prosperous.

Marls.—The production in the Southern States, particularly in Virginia, North Carolina, Alabama, Mississippi, and Florida, is increasing, while the product of New Jersey did not vary from 1887. About 600,000 tons, valued at \$300,000, were produced.

Salt.—The industry shows only slight changes. In 1888 the production was 8,055,881 barrels of 280 pounds, valued at \$4,377,204. In 1887 the product was 8,003,962 barrels, worth \$4,093,846. Kansas became a commercial source of salt in 1888, producing 155,000 barrels, with a prospect of still greater increase in 1889.

Bromine.—The product was 307,386 pounds, worth \$95,290, an increase from 199,087 pounds in 1887, worth \$61,717. The price remained at 31 cents per pound.

Borax.—The production was restricted to 7,589,000 pounds, worth \$455,340, at 6 cents per pound for the average quality. In 1887 the product was 11,000,000 pounds, worth 5 cents per pound.

Sulphur.—The sulphur-refinery in Utah was partially burned. This and litigation over the property prevented any production in 1888. The supply came principally from Sicily, with small importations from Japan. It was practically all made into sulphuric acid.

Pyrites.—Production, 54,331 long tons, valued at the mines at \$167,658, a slight increase in quantity over the previous year.

Barytes.—The production from Missouri, Virginia, and New York increased to 20,000 long tons, worth at the mines \$110,000. In 1887 the product was 15,000 long tons, worth \$75,000.

Gypsum.—The domestic supply comes principally from Ohio and Michigan, with smaller amounts from New York, Virginia, Kansas, Colorado, California, Dakota, and Utah. The product in 1888 was 96,000 short tons of crude gypsum, valued at \$430,000. A large portion of the supply is imported from Nova Scotia, where 126,118 tons, worth \$121,579, were produced in 1888.

Ozocerite.—From the region of Soldier's Summit, Utah, about 20,000 pounds of crude mineral wax were produced, worth \$1,000 in New York, where the material was sold. An increase is probable in 1889.

Soapstone.—Production about 15,000 tons, worth \$50,000 before shipment.

Asphaltum.—The product of 1888 includes 700 tons of gilsonite mined in Utah; 3,100 tons of ordinary asphaltum, principally from California; and 50,000 tons of bituminous rock quarried in California for pavements in competition with asphaltum; total value, \$331,500.

Felspar.—The consumption for potters' use declined to 8,700 long tons, worth, in Trenton, N.J., \$50,000. In 1887, 10,200 long tons were produced, worth \$56,100.

Flint.—For potters' use the consumption was 16,250 long tons. Including that for sandpaper and for glass, the consumption was about 30,000 tons, worth, unground, \$175,000.

Potters' Clay.—The consumption included 18,000 long tons of kaolin or china-clay, 5,250 tons of ball-clay, and 13,500 tons of fire-clay, worth altogether \$300,000.

Mica.—Owing principally to the use of smaller sizes in stoves, the production of sheet mica decreased from 70,500 pounds in 1887 to 48,000 in 1888, valued at \$70,000. There is increased demand for mica waste.

Mineral Paints.—The product, including ochre, metallic paints, and small amounts of umber and sienna, increased to 24,000 long tons, valued at \$380,000.

Graphite.—The production of pure graphite was limited to Ticonderoga, N.Y., and is reported as unchanged. The total production of pure material was 400,000 pounds, worth \$33,000. Small amounts of less pure material for foundry facings, etc., were produced in North Carolina, and at Cranston, R.I.

Fluorspar.—The production limited to the neighborhood of

Roseclare, Ill., and Evansville, Ind., is reported at 6,000 tons, worth \$30,000, an increase of 1,000 tons over 1887.

Insufioral Earth.—The product came principally from Maryland, and amounted to 2,500 short tons, worth, before shipment, \$12,500.

Zircon.—During 1887 and 1888, 25 tons of zircon were mined, principally in Henderson County, N.C., and sold for \$10,000 for the manufacture of incandescent gas-burners. About 4 tons of monazite, 1 ton of allanite, 600 pounds of samarskite, and \$500 worth of yttrium minerals were produced for the same use. About 6 tons of monazite and 5 tons of cerite were also imported.

Mineral Waters.—Amount sold in 1888, 9,628,568 gallons, valued at \$1,709,302. In 1887 the product was 8,259,609 gallons, worth \$1,261,473.

Totals.—The total value of the minerals produced in 1888 was \$591,659,931. It is recognized that this is the sum of the values of substances taken in various stages of manufacture, and hence not strictly comparable with each other; still it is the most valuable means for comparing the total products of different years. The result is an increase of nearly \$50,000,000 beyond the value of the product in 1887. In that year nearly every mineral industry showed an increase, and hence an increased total was evident. But the fact that the increase was so very large was due to rather exceptional conditions in a few important industries, and it could not reasonably be expected that a similar combination of circumstances would result in even a larger total value for 1888. Nevertheless the unprecedented stimulus given to the production of copper by an artificial price increased the total value of that product nearly \$13,000,000, or nearly enough to offset the decline in the total value of pig-iron. The other important factors in the increase were coal and the other fuels, which followed the increased quantity of metals. With the anticipated decline of copper to the normal demand, a decline in the total value of the product in 1889 will not be inconsistent with the natural development of our mineral resources.

THE RAINFALL OF THE PACIFIC SLOPE.

GEN. A. W. GREELY, in compliance with the resolution of the Senate, dated Jan. 4, 1888, has compiled an interesting report on the maximum annual, minimum annual, and on the mean precipitation for each month of the year, for the Western States and Territories, the main part of which is a series of charts. The record from which these charts have been compiled aggregates 4,800 years for 661 stations, thus giving an average of seven years, and three months to each station. The separate records, however, vary from two to forty years in length. The principal object of the report is to clear up the important question of the extent of the arid lands. Regarding this point, the chief signal officer says,—

“One great result which must redound to the benefit of the trans-Mississippi and trans-Missouri country by the publication of these official data will be the dispelling of erroneous and injurious impressions which have long prevailed regarding this region. In the early part of this century this territory was viewed as hardly suited for civilized man; its enormous plains and vast mountains being represented as arid and desert regions, unsuited for cultivation, and in many places even unfit for pasturage. Adventure, exploration, and circumstance have pushed the frontier westward, until the myths of the Great American Desert to the north, and of the rainless ‘staked plains’ to the south, have practically disappeared. It is none the less true, however, that the latest and most reliable text-book of meteorology of this country speaks of the areas between the Sierra Nevada and the Rocky Mountains, including portions of Utah, New Mexico, and California, as a region which is almost entirely destitute of rain, and that farther on the east side of the Rocky Mountains the country is a barren desert, almost without rain.

“As to the value of these charts, there should exist no reasonable doubt, since they not only show prospective settlers in these States and Territories the probable rainfall conditions, but likewise show it to parties contemplating industrial, agricultural, stock, and other investments in these extensive regions. It is evident to all, however, that the rainfall conditions for separate years vary quite considerably; and, indeed, the opinion has been put forth that

these variations are not only enormous, but are so irregular as to render their prediction impracticable, and even that rain does not fall for years in certain sections.

“An examination of the charts of maximum annual rainfall and minimum annual rainfall of these regions shows clearly that rainfall conditions are considerably more equable than has been generally believed; so that the isohyetal lines are quite as regular on these charts of maxima and minima conditions as on those of average conditions. The minimum rainfall has never reached zero for any year, and annual or seasonal rainfalls less than one inch have occurred in south-western California and south-western Arizona at few stations only. These maps of maxima and minima precipitation must be of great practical value as showing the settler or investor exactly the extreme conditions which he must expect to experience in these regions. Another great value of the charts is the bringing to general attention and consideration very extensive areas of country in what has been known as the arid region, where late

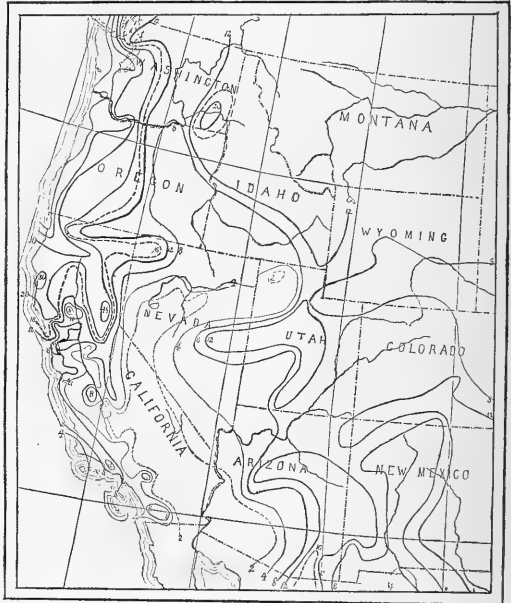

LEAST ANNUAL RAINFALL ON THE PACIFIC SLOPE.

and careful observations have shown the rainfall to be far greater than has been usually attributed, and thus transfer these areas to the sub-humid districts.

“The great extent to which misapprehension as to the rainfall conditions of the arid regions has been corrected by these charts is evidenced by the fact that the area on which the mean annual rainfall is less than ten inches, shown on statistical maps of the ‘Tenth Census’ at 241,000 square miles, has been reduced to 126,000 square miles; while a similar reduction is shown in the area of country where the yearly rainfall is between ten and fifteen inches, which, given in the census chart at 385,000 square miles, is now limited to 259,000 square miles. In other words, the area over which less than fifteen inches of rain fall annually has been reduced almost a quarter of a million (241,000) square miles. A large area of country charted on the statistical map as having an average rainfall of less than five inches now entirely disappears in Texas, New Mexico, Utah, and Oregon, and is materially reduced in Nevada, Arizona, and California.

“Observations over a small, compact agricultural area of South Australia afford very reliable data as to the effect of rainfall upon annual wheat yields. It appears from these observations that

twelve inches of rain in the six winter months produce six bushels of wheat per acre, and that for every increase of rainfall of an inch a like increase occurs in the average production of bushels of wheat per acre."

The minimum rainfall is undoubtedly of the greatest importance to agriculturists, and we reproduce here a portion of the map of minimum rainfall. The point at which a region may be classed as arid, and unfit for successful agriculture, is believed by Gen. Greeley to be fifteen inches. This amount of annual rainfall is not considered sufficient for all crops, nor on all kinds of soil, but may be assumed as an average. Exact observations upon these points are lacking in the United States; but in Australia, observations and experiments have been made, covering now quite a number of years, on wheat, which may be called a test-crop.

The fact that wheat can be grown without irrigation, in a country where the annual rainfall is less than twenty inches, is evidenced by official statistics from Dakota, which show that wheat is grown by tens of millions of bushels yearly in sections where the rainfall ranges from twenty inches downward. In that region over three million bushels of wheat are now grown annually in counties where the rainfall ranges from fifteen and one-tenth down to thirteen and eight-tenths inches.

Perhaps the most careful observations in connection with the effect of rainfall upon pasturage have been made in Australia, the question being very important owing to the immense arid regions in that country. It has been set forth, and probably with a fair degree of authority, that annual rainfall is a most reliable index as to the pastoral capacity of a country, since grass benefits by rain at any season. Australian records show that land favored with less than ten inches of rain a year is quite valueless without irrigation. In such regions only one sheep per square mile can be carried for each inch of rainfall. For from nine to thirteen inches, however, the increase is about twenty sheep per square mile, and for from thirteen to twenty inches of rainfall the increased carrying capacity is about seventy sheep per square mile.

It has been estimated that the sandy land in the San Joaquin valley, California, would feed about one sheep to the acre in its natural state; but when irrigated, and growing alfalfa, it carries twenty.

The question of the amount of minimum rainfall, and of its distribution according to seasons and years, is one of prime importance for the development of the Western States and Territories; and careful and long-continued researches on the meteorological conditions, more particularly on the precipitation, will be of the greatest value to settlers. The chief signal-officer concludes his report with a recommendation to extend observations upon the rainfall in the Western States and Territories by a gratuitous distribution of gauges to reliable voluntary observers who reside in counties from which rainfall reports are not now obtainable.

PRIMARY EDUCATION IN GERMANY.

It is commonly held that in Germany the public-school system, beginning with the university and ending with the primary school, has reached a higher degree of excellence than has been attained anywhere else. The term "Germany" as generally used in this connection is somewhat vague; for the schools are managed differently in different parts, and the various systems are not equally good. In an article in the *Journal of Pedagogy* by O. B. Super of Dickinson College, Carlisle, Penn., a view is given of the system where it has reached its highest excellence.

The first point requiring attention is, that in Germany every thing relating to schools of any kind is done according to a regular system; and this, of course, is a great advantage, to begin with. We sometimes talk of our public school system, but it would be difficult to say what that system is. Ever since there have been white men in America, means have usually been found to give most of the rising generation some kind of an education; and this is about all we can boast of now, for, under the existing order of things, a very large number of children get no education. The census of 1880 shows that we have among us 6,239,958 children who cannot write their names, and this fact alone is enough to prove

that our so-called system comes very far short of doing what it ought to do.

The German Government is careful, first, that suitable buildings are erected for school purposes, and then looks to it that they are provided with proper furniture, books, apparatus, and teachers. Before a new school-building can be erected, the law requires attention to the following particulars: the location must be central; it must be removed from busy streets and noisy or ill smelling factories; the ground must be dry and with sufficient elevation to allow of proper drainage; there must be a dry and clean yard large enough for a play-ground; and the government provides swings, cross-bars, and other appliances for out-door gymnastics. School architecture in America usually depends very much on the character or intelligence of the man who has undertaken the "job." The government further provides the following apparatus for every school: in the primary grades, alphabetical charts, abacus, the metric ruler, two black-boards, a wall-map of the province in which the school is located, a relief-map of Germany, a wall-map of Palestine, and some charts of natural history. In the grammar and high school grades there is much more, including chemical and philosophical apparatus.

But the great point of superiority of their schools lies in the teachers. A good teacher will have a good school in spite of all drawbacks, and a poor teacher will have a poor school in spite of all advantages of building and apparatus. The reason why German teachers, as a rule, are superior to ours, is that the former have been specially trained for their work. With us it seems to be a generally accepted theory that almost any one can teach, provided he knows just a little more than the persons of whom he is to have charge. In Germany, teaching, even in the primary schools, is recognized as a profession, which unfortunately is not the case in this country. Here the average teacher might with propriety be called a sort of "pedagogic tramp;" for in country districts, at least, the same teacher rarely has the same school two successive terms, and the records of some counties in Pennsylvania show that every year more than one-third of the schools have teachers that are entirely without experience, and in many cases they have just "graduated" from the country schools themselves. It will doubtless be found that the same condition of affairs prevails in every State west of Pennsylvania. A very large majority of public-school teachers, if they are men, are only using this occupation as a convenience until they are able to find something more suited to their tastes. If they are women, the probabilities are that in a few years they will marry; and, if they have any thing to do with managing children after that, it will not likely be in the public school. In either case, teaching is looked upon as something one ought to get out of as soon as possible.

In Germany no one is permitted to teach, even in a primary school, unless he has satisfactorily completed the course of study prescribed by the "Teachers' Seminary." Even private schools are subject to the same rigid supervision as the public schools, and no one is allowed to set up a school until he has demonstrated his fitness to teach. With us, private and parochial schools are not seldom worse than the public schools; for, while the former usually have some kind of supervision, the latter have no authorized overseers at all.

In order to be admitted to a "Teachers' Seminary," the applicant must be between sixteen and twenty-four years of age; must have a certificate from his former teacher, testifying to his moral character, good habits, industry, and ability; and must be able to pass an examination in what are usually called "common-school" branches, together with history of Germany, elements of natural philosophy, religious doctrine, and Bible history and music. At the seminary he studies all these, and some higher branches in addition. After completing this course, he must serve two years as assistant to an experienced teacher. If he sustains this ordeal, he is then required to pass a final examination, when he is supposed to be fit to take charge of a low-grade school; but he has now been raised to the rank of a "school-master," is recognized and honored as a member of a noble profession, with a position for life, and a salary that is not large but always sufficient to enable him to maintain his position with respectability, and with the certainty that if he does his work well he will be promoted to the

higher grades of his profession. An examination is necessary before every promotion; so that he must not only teach well, but must keep up with what is going on in the branches which he is required to teach. He teaches about thirty hours a week for ten months of the year, receiving a salary ranging from twenty-five dollars to ninety dollars per month, and a house free of rent. Considering the price of living, this is better compensation than the average American teacher gets. The average salary of the 23,681 teachers in Pennsylvania is \$34.35 per month, and the report from which these figures are taken does not give the lowest salary paid. In some instances it is probably not more than ten dollars a month. As showing the transitory nature of the teacher's occupation in this country, it may be stated, that, of the above twenty-three thousand teachers, over eight thousand had been in the work less than five years. To judge from a statement made some years ago by a prominent Ohio educator, the tenure in that State is still more unstable. Besides, the German village schoolmaster is socially the equal of any of his neighbors, and he and the pastor are the most important personages in the place.

After the German teacher has served ten continuous years, his salary is increased by a small yearly pension; and if he should, on account of age or for any other reason, be unable to continue his labors, his pension is so increased as to afford him a comfortable living. If he dies and leaves a widow, she is pensioned, as are also all children under the age of twelve years whom he may happen to have. The State thus recognizes the teacher in the public school as being of equal value with the soldier; for, if either is disabled in the service, he is pensioned; and if he dies, his family is provided for.

It must not be inferred, from what has been said above, that it is advocated to transfer, as a whole, the German public-school system to the United States. We must make our own system, not borrow one already made. The only object has been to show that in the way of public schools we have more to learn of some European countries than they of us. While it is freely admitted that we have many schools quite as good as any that can be found elsewhere, yet one need only keep his eyes open in order to become fully aware that we have many schools and school-teachers that could not exist under the system sketched above.

DO WARM SUMMERS FOLLOW WARM WINTERS?

ALMOST every newspaper of Boston has recently had something to say about what the weather is to be during the coming summer; and it seems to be an almost unanimous conclusion that the following summer is to be warm because the winter and spring have been warm, or because last summer was cool. This has led Mr. H. H. Clayton to examine the temperature observations made in Milton during the last forty years by Mr. Charles Breck. These observations have been made twice daily from the same thermometer, hanging in the same place since the beginning of the observations in January, 1849. During the forty years, nineteen winters have been warmer than the average, and eight of the following summers have been warmer than the average. There have been eleven cases in which both the winter and spring have been warmer than the average, and following these there have been five summers warmer than the average. There have been six decidedly warm winters, that is, winters whose mean temperature was three degrees or more above the average; and four of the following summers have been warmer than the average. It is seen, then, that only about half of the warm winters were followed by warm summers; or, in other words, cool summers have followed warm winters as often as the reverse. The number of times warm summers have followed cool summers is nine, while the number of times cool summers have followed cool summers is twelve.

In the above, what has been called a warm winter is one in which the mean temperature of the three winter months—December, January, and February—has been higher than the average of forty years; and what has been called a cool summer is one in which the mean temperature of the three months of June, July, and August has been lower than the average of forty years, etc. This, however, is evidently not the definition adopted by people generally in deciding whether a winter or summer is colder or warmer than

usual, for a decided departure of the temperature of a single month in any direction may determine the impression people retain of the entire season. Thus it will surprise most people to learn that the mean temperature of last summer was slightly higher than the average of the last forty years. Both June and August were warmer than usual, and only July was very cool. It will probably be a still greater surprise to learn that the winter of 1887-88, which was generally thought to be a cold winter, was really slightly warmer than usual. December and February were both warmer than usual, and January alone was very cool. Thus people's opinion of a season seems to be largely moulded by the special character of what is usually the most extreme month of the season. If in winter January happens to be exceptionally warm or cold, the winter is decided to be of the same character; or if July happens to be decidedly warm or cool, the summer is thus characterized. It seemed, then, worth while to ascertain from Mr. Breck's record how many warm Julys followed decidedly warm Januaries. There were eight Januaries during the forty years whose average temperature was above 30°, and following these were five Julys warmer than the average of forty years; which indicates but a slight tendency for warm Julys to follow warm Januaries, since the law of chance would indicate that four warm Julys ought to follow eight warm Januaries. The number of times warm Julys have followed cool Julys is twelve; and the number of times cool Julys have followed cool Julys is eight.

Another method frequently used in predicting the weather of a coming season is based on the conclusion that during every year the average conditions remain about the same; and if the first part of the year is very warm, the latter part must be cool. This assumption, however, appears to be entirely unsupported. Mr. Breck's observations show that the mean temperature of one year may differ as much as five degrees from another. Eleven months of 1877 were observed to be warmer than usual, and nearly as great departures in the opposite direction were found in other years.

All of these facts indicate that no conclusion of any value greater than could be gained by mere guessing can be formed in regard to the character of a coming season, merely by knowing the character of a past season, until some law connecting these is worked out. This has been demonstrated over and over again in different parts of the world; but since, of course, people generally cannot keep posted in meteorological literature, there will probably continue to appear such forecasts of coming seasons, based on apparent scientific conclusions. Mr. Clayton feels sure there is a law of recurrence of meteorological phenomena besides the daily and annual periods, and also that it is not of the character usually supposed and discussed above.

NOTES AND NEWS.

IN an account of the Widdifield & Bowman Company's electric and automatic car-brake, in *Science* of May 31, p. 412, second column, 10 lines from the bottom, "in 11 seconds" should read "in 77 seconds." This company now have an office at Room 125, Temple Court, this city.

— Dr. Hellmann has published, in the *Centralblatt der Bauverwaltung*, a brief study of a cloud-burst, Aug. 2 and 3, 1888, in the Riesengebirge, in Silesia. The storm was on the west side of a storm area which was moving northward from Galicia. The rain fell from fifteen to eighteen hours, and in some parts of the Queiss valley its depth reached 200 millimetres, or 7.9 inches. Such a rainfall had not been known there before since 1804. A similar cloud-burst occurred in the region just south-east of this, in the Sudeten and Beskiden Mountains, in 1884, accompanied by a similar unusual progression of a storm area northward over Galicia and Polen.

— The governing committee of the Nineteenth Century Club of New York reports, that, notwithstanding the shadow cast over the club by the death of its founder and president, the last season has been a successful one. The meetings have been marked by a full and sometimes a crowded attendance, the membership is substantially unimpaired, and, so far as the committee can judge, the interest in the club's work remains unabated. The committee believes that nothing more is necessary than to continue on the same

lines, relaxing no effort to make the discussions as interesting as possible, but making no distinctive change in its policy. The secretary's report shows during the past half-year twelve resignations, balanced by the accession of twelve new members. There are at present seventy-one candidates upon the books. The number of gentlemen (104) is still considerably in excess of that of ladies (76). The lecture committee does not make a formal report till the fall meeting, but has reported informally that arrangements are making which will result in a very interesting and brilliant programme next winter. During the past season there has been a preponderance of political topics, owing to the fact that two discussions had to be postponed on account of sickness and death. Mr. Thomas Nelson Page will next season, however, deliver his lecture on the new Southern literature, Richard Watson Gilder of the *Century* to participate in the discussion. Mr. Bronson Howard will also deliver his address on dramatic construction, Mr. A. M. Palmer to be one of the other speakers. Hon. Seth Low has agreed to address the club on the subject, "A Metropolitan University." Three evenings are thus definitely arranged for. There may be also the postponed address from Mr. Frank J. Potter on folk-music, and Mr. George Kennan on some phases of Russian life. There are hopes of securing Sir Edwin Arnold and some other very distinguished men. A most important matter is the offer of Mr. Andrew Carnegie to furnish rooms for the club in his new Music Hall, to be erected at the corner of Seventh Avenue and 57th Street. This very generous offer will enable the club, after next season, to have permanent quarters. Meantime it is possible that in the autumn there may be other plans to consider, in addition to this one; but certainly the club will be obliged for the next winter to occupy the assembly rooms at the Opera House, though the effort will be made to get Tuesday, Thursday, or Friday evenings instead of Wednesday.

— The headquarters of the National Electric Light Association are now located at 18 Cortlandt Street, this city, to which place members are requested to send all notices of change of address or business. The secretary of the association desires to correspond with all present or prospective members manufacturing or dealing in electrical apparatus or supplies, with a view to arranging for an exhibition in connection with the summer meeting at Niagara Falls in August. Negotiations have been consummated with several railroad companies whereby visitors to that meeting will be enabled to travel at reduced rates, and similar negotiations with other companies are pending. A special limited vestibule train, for the exclusive use of delegates to the meeting, has been provided. A special car in this train will be reserved for gentlemen accompanied by ladies. In connection with the proposed exhibition, it is stated that the exhibit at the Chicago convention grew to so large proportions, and the expense was so great, that both the exhibitors and the executive committee took formal action before leaving Chicago, discouraging a large exhibit at Niagara Falls. It is found, however, that some members of the association are members for the sole purpose of making exhibits at the conventions; others have novelties brought out during the current half-year; and some insist on making an exhibit at any rate. It has been thought best, therefore, to provide for an exhibit on a moderate scale, and a number of rooms have been engaged in direct connection with the Convention Hall. Indications are that the Niagara Falls convention will be a large one. There seems to be a prevailing sentiment in favor of the attendance of the wives and lady friends of the members, and special arrangements will be made for their comfort and entertainment.

— Mr. W. H. H. Beadle writes from Chemawa, Ore., to the *American Meteorological Journal*, that as thunder is rare, and by some said not to occur in Oregon, it may be noted for record that at 11.53 A.M., standard time, April 22, peals of thunder and the characteristic rolls and reverberations were heard to the eastward from this place, which is near Salem in the Willamette valley. There was evidently a marked "low." It had rained heavily in the morning, after twenty-four hours southerly wind, and had partially cleared. The sun shone very warm, and a thunder-cloud, such as is common in Michigan summers, passed across the eastern sky from south to north.

— A rather singular personal discussion is just now going on in Vienna, over the new Court Theatre, which is very magnificent, but which has the defect that the actors cannot be heard in it. The architect is Baron von Hasenauer, one of the most distinguished architects in Europe, and the newspapers seem to have been stimulated by his conspicuous professional position to lay a good deal of blame on him for the bad acoustic quality of the building. Naturally, Baron Hasenauer does not like this; and his friends have undertaken to defend him by explaining that the plan of the structure is not due to him, but to the late Professor Semper, who prepared before his death the scheme which was carried into execution by Hasenauer. This explanation, which has probably some reason in it, far from allaying the trouble, has, as it seems, stirred up Professor Hans Semper, the son of the great architect, who demands an opportunity to demonstrate before a jury of architects that the defects of the theatre arise from errors in design and construction which do not exist in the original plans, but were introduced by Baron Hasenauer. Which of the disputants is right it is impossible to say; and, in fact, in matters of the acoustics of buildings, it is beyond the power of any person, architect or not, according to *The American Architect*, to make explanations that are of any value, beyond the most rudimentary observations, for the reason that no one knows, beyond such simple observations, anything about the causes which make a building hard to hear in, or the remedy for such a state of affairs if it exists. Meanwhile, Baron Hasenauer's friends, including Baron Hansen and many other architects of high distinction, have shown their sympathy with him by presenting him with a eulogistic address.

— A device for secret writing by means of the type-writer is mentioned in the *Paper World* as a recent invention. It requires two type-writers similarly adjusted. They are so constructed that the types can be shifted from their normal position; so that the operator, striking the key in the usual way, really writes other letters than those in his copy, forming a cipher copy. The receiver adjusts his machine in an opposite direction, and writes from the cipher copy, and his machine records the letters of the original copy. The principle is very simple, says the *Mechanical News*, and it at once suggests the possibility of applying the principle of the combination lock to such a contrivance for all type-writers, so that each owner of a machine can set it to any combination, which only he and his correspondent should know. This must be feasible; and, if the new invention is of any use at all, its usefulness would be much increased by such a plan.

— Attention has lately been called by the *Philadelphia Press* to the peculiarly corrosive, and consequently destructive, effect of the creosote of wood-soot upon chimneys, owing to the fact that the creosote thus formed from the slow combustion of wood contains so large a proportion of pyrolicious vinegar or crude acetic acid, this acid being formed in large quantities when the combustion of wood is slow; many quarts, in fact, being condensed in cold weather where a large wood-fire is very much checked, only a few hours being required for such condensation. The acid in question dissolves lime readily, carrying it away in solution, and in this manner the mortar is frequently entirely removed from the tops of chimneys in the country, new ones suffering in the same way as the old, instances being numerous where the top courses of brick in chimneys only two years old have become entirely without support other than that afforded by the sand with which the lime was mixed.

— The annual commencement of the University of Pennsylvania — or rather its second yearly commencement, as the three medical faculties held theirs earlier in the year — shows, says *The American*, how much the old monotony of the single course in arts has been broken of late years. Graduates in science, in biology, and in finance, besides those of arts and of the law school, swelled the number to 106. The Wharton School of Finance graduated a strong class of young men deeply interested in the great public questions which are the especial subjects of instruction in this school. One of the class is Mr. Tamio Hayashi, who comes from Japan to learn political economy of the genuine American type. There are three of his countrymen in the class which graduates

next year, and others are preparing to enter. It is proposed to establish in the college faculty a course of study in which the biological sciences will hold the place of honor. In Drs. Leidy and Rothrock and their younger associates in the biological faculty, the university already possesses the means to create a strong school, and we hope the public support will be ample and encouraging.

— A new substance, singular alike in its chemical nature and in its properties, says *Nature*, has been discovered by M. Péchard. It is a mixed acid derived from oxalic and molybdic acids, and is therefore termed "oxalomolybdic acid." The crystals of oxalomolybdic acid, when dry, may be preserved unchanged either in sunshine or in the dark; but, if moist, they quickly become colored blue when exposed to the sun's rays. If characters be written on paper with the solution, they remain invisible in a weak light; but, when exposed to sunshine, they rapidly become visible, turning to a deep indigo color. It is curious that this effect only happens when the solution is spread over paper or other surfaces; for the solution itself may be kept unaltered in the bottle for any length of time, except for a trace of blue at the edge of the meniscus, where, by surface action, a little is spread against the interior glass walls. If a sheet of paper be immersed in a saturated solution of the acid, dried in the dark, and then exposed behind an ordinary photographic negative, a very sharp print in blue may be obtained by exposure to sunlight for about ten minutes. The color instantly disappears in contact with water; so that, if a piece of this sensitized paper be wholly exposed to sunlight, one may write in white upon the blue ground by using a pen dipped in water. If, however, the paper with its blue markings be exposed to a gentle heat for a few minutes, the blue changes to black, and the characters are then no longer destroyed by water.

— The Hydrographical Department of Russia has devoted since 1837, according to *Nature*, a good deal of attention to the secular rising of the coasts of the Baltic Sea, and a number of marks have been made on the rocky coasts of the Gulfs of Bothnia and Finland in order to obtain trustworthy data as to the rate of the upheaval of the coasts. Since 1869, observations have been carried on in a systematic way for measuring the changes in the level of the Baltic at several of the above-mentioned marks, and the results of the observations are now summed up by Col. Mikhailoff in the *Izvestia* of the Russian Geographical Society (vol. xxiv. 3). Taking only those stations at which the secular change could be determined for a number of years, varying from thirty-one to thirty-nine years (1839-78), the rise of the coast in a century would appear to be as follows: Aspö, 20.3 inches; Lehtë, 11.5 inches; Island of Kotkö, 26.7; Sveaborg, 22.8 and 25.1; Hangöudd, 33.7; Island of Skotland, 12.5; Island of Jussari, 31.6; Tverminö, 36.2; Island of Gloskär at Redhamn, 12.2. It thus appears that the figure of about three feet in a century, which was deduced from former observations, cannot be very far from the truth. As to local anomalies, they remain still unexplained.

— Carpenters and other tool-users who keep up with the times now use a mixture of glycerine, instead of oil, for sharpening their edge-tools. Oil, as is well known, thickens, and smears the stone. The glycerine may be mixed with spirits in greater or less proportion, according as the tools to be sharpened are fine or coarse. For the average blade, two parts of glycerine to one of spirits will suffice.

— The Elizabeth Thompson Science Fund, which has been established by Mrs. Elizabeth Thompson of Stamford, Conn., "for the advancement and prosecution of scientific research in its broadest sense," now amounts to twenty-five thousand dollars. As accumulated income is again available, the trustees desire to receive applications for appropriations in aid of scientific work. This endowment is not for the benefit of any one department of science, but it is the intention of the trustees to give the preference to those investigations which cannot otherwise be provided for, which have for their object the advancement of human knowledge or the benefit of mankind in general, rather than to researches directed to the solution of questions of merely local importance. Applications for assistance from this fund, in order to receive consideration, must be accompanied by full information, especially in regard to the fol-

lowing points: 1. Precise amount required; 2. Exact nature of the investigation proposed; 3. Conditions under which the research is to be prosecuted; 4. Manner in which the appropriation asked for is to be expended. All applications should be forwarded to the secretary of the board of trustees, Dr. C. S. Minot, Harvard Medical School, Boston, Mass., U.S.A. It is intended to make new grants at the end of 1889. The trustees are disinclined, for the present, to make any grant exceeding five hundred dollars: preference will be given to applications for smaller amounts. The following is the list of grants made: \$200 to the New England Meteorological Society, for the investigation of cyclonic movements in New England; \$150 to Samuel Rideal, Esq., of University College, London, England, for investigations on the absorption of heat by odorous gases; \$75 to H. M. Howe, Esq., of Boston, Mass., for the investigation of fusible slags of copper and lead smelting; \$500 to Professor J. Rosenthal of Erlangen, Germany, for investigations on animal heat in health and disease; \$50 to Joseph Jastrow, Esq., of the Johns Hopkins University, Baltimore, Md., for investigations on the laws of psycho-physics; \$200 to the Natural History Society of Montreal, for the investigation of underground temperatures; \$210 to Messrs. T. Elster and H. Geitel of Wolfenbüttel, Germany, for researches on the electrization of gases by glowing bodies; \$500 to Professor E. D. Cope of Philadelphia, Penn., to assist in the preparation of his monograph on American fossil vertebrates; \$125 to E. E. Prince, Esq., of St. Andrews, Scotland, for researches on the development and morphology of the limbs of teleosts; \$250 to Herbert Tomlinson, Esq., of University College, England, for researches on the effects of stress and strain on the physical properties of matter; \$200 to Professor Luigi Palmieri of Naples, Italy, for the construction of an apparatus to be used in researches on atmospheric electricity; \$200 to William H. Edwards, Esq., of Coalburg, W. Va., to assist the publication of his work on the butterflies of North America; \$150 to the New England Meteorological Society, for the investigation of cyclonic phenomena in New England; \$25 to Professor A. F. Marion, for researches on the fauna of brackish waters; \$300 to Professor Carl Ludwig, for researches on muscular contraction, to be carried on under his direction by Dr. Paul Starke; \$200 to Dr. Paul C. Freer, for the investigation of the chemical constitution of graphitic acid; \$300 to Dr. G. Müller, for experiments on the resorption of light by the earth's atmosphere; \$300 to Professor Gerhard Krüss, for the investigation of the elementary constitution of erbium and didymium; \$50 to Dr. F. L. Hoorweg, for the investigation of the manner and velocity with which magnetism is propagated along an iron bar; \$150 to Mr. William H. Edwards, to assist the publication of his work on North American butterflies.

— Charles A. Ashburner, the well-known Pittsburgh geologist, had the honorary degree of doctor of science conferred upon him at the commencement of the University of Pennsylvania, June 7, as an acknowledgment of the high scientific value and merit of his surveys and reports for the Geological Survey of Pennsylvania. Dr. Ashburner was graduated from the University of Pennsylvania about fifteen years ago with the highest rank in his class, and immediately entered the corps of the United States Lighthouse Service Survey. Upon the organization of the Pennsylvania Geological Survey, he resigned from the government work, and was appointed assistant of Professor Lesley, State geologist, with whom he has been associated ever since. About two years ago he gave up much of his active State work, and went to Pittsburgh to assume connection with Mr. Westinghouse in his extensive mining interests, particularly in the mining of natural gas; latterly, however, making extensive geological and mining examinations in the Rocky Mountains and on the Pacific slope.

— MM. Mannesmann of Remscheid, Westphalia, are manufacturing fly-wheels capable of double and even treble the speed of fly-wheels made of cast-iron, the resistance of which is generally limited to a speed of forty metres per second for the rim of the wheel. They have succeeded in obtaining fly-wheels which are capable of acquiring three times the speed of ordinary fly-wheels by constructing the nave and the spokes of iron or steel, and making a rim entirely of steel wire wound round and round itself a great many times.

SCIENCE:

A WEEKLY NEWSPAPER OF ALL THE ARTS AND SCIENCES.

PUBLISHED BY

N. D. C. HODGES,

47 LAFAYETTE PLACE, NEW YORK.

SUBSCRIPTIONS.—United States and Canada.....\$3.50 a year.
Great Britain and Europe..... 4.50 a year.

Science Club-rates for the United States and Canada (in one remittance):

1	subscription 1 year.....	\$ 3.50
2	" 1 year.....	6.00
3	" 1 year.....	8.00
4	" 1 year.....	10.00

Communications will be welcomed from any quarter. Rejected manuscripts will be returned to the authors only when the requisite amount of postage accompanies the manuscript. Whatever is intended for insertion must be authenticated by the name and address of the writer; not necessarily for publication, but as a guaranty of good faith. We do not hold ourselves responsible for any view or opinions expressed in the communications of our correspondents.

VOL. XIII. NEW YORK, JUNE 14, 1889. No. 332.

CONTENTS:

WESTINGHOUSE ALTERNATING-CURRENT DYNAMO..... 451	EDITORIAL..... 462
GEOLOGICAL SURVEY OF NEW JERSEY..... 452	The Prevention of Consumption.—The Health of Providence, R.I.—An American Chemical Society.
THE MEDBERRY UNDERGROUND SYSTEM..... 453	CLARK UNIVERSITY..... 462
EDIBLE MUSHROOMS OF THE UNITED STATES..... 453	TO PREVENT CONSUMPTION..... 465
MINERAL PRODUCTS OF THE UNITED STATES..... 455	SIXTH ANNUAL REPORT OF THE SUPERINTENDENT OF HEALTH OF PROVIDENCE..... 466
THE RAINFALL OF THE PACIFIC SLOPE..... 457	BOOK-REVIEWS.
PRIMARY EDUCATION IN GERMANY.. 458	Mechanics of Engineering..... 468
DO WARM SUMMERS FOLLOW WARM WINTERS?..... 459	Elementary Synthetic Geometry of the Point, Line, and Circle in the Plane..... 468
NOTES AND NEWS..... 459	Go to the Ant and learn Many Wonderful Things..... 468
	A Treatise on Spherical Trigonometry..... 468
	A Laboratory Guide in Chemical Analysis..... 468
	Elementary Statics..... 470
	AMONG THE PUBLISHERS..... 470

SOME TIME SINCE, WE REFERRED to the appointment of a commission by the New York City Board of Health for the purpose of formulating a concise statement regarding the contagiousness of tuberculosis and the means of protection therefrom. This commission was formed of Drs. Prudden, Biggs, and Loomis, pathologists to the Board of Health, and in this number we publish their report. In this report the position is taken that consumption is not necessarily an hereditary disease, and that in certain stages its cure is possible. If this dread disease may now be ranked among preventable evils, it is desirable that this should be widely known, and that the means by which this result may be reached may be understood by the public at large. To aid a free discussion of the questions at issue, we print on one of our advertising pages a few questions to which we should be pleased to receive answers.

THE REPORT of the superintendent of health of Providence, a full abstract of which we give in this number, contains many items of interest. The most important of these is the statement that typhoid-fever germs were found in three of the filters in use in that city, in houses where typhoid-fever existed. In this report Dr. Chapin states that the house-filters in common use collect filth and microbes from the water, and act as incubators for the latter. There is no doubt, that, when first put into use, a filter may be of

advantage so far as sifting out the grosser particles of suspended matter; but it soon becomes itself filthy, and the constantly accumulating filth furnishes the most favorable nidus for the growth of disease-germs.

THE CELEBRATION OF THE CENTENNIAL of the discovery of oxygen at Priestley's grave at Northumberland, Penn., in 1874, by a gathering of distinguished American chemists, was the occasion for the suggestion of the formation of an American chemical society, with headquarters in New York. This suggestion was due principally to H. Carrington Bolton; but nothing resulted until 1876, when the American Chemical Society was started, with J. W. Draper as president. After him Dr. J. Lawrence Smith, Professor C. H. Chandler, and Dr. James C. Booth filled the presidential chair. The meetings flourished for a time; but, after a little, the more prominent New York members failed to appear with any regularity, and the management of the society fell into the hands of the lesser members, with the result of a languishing condition of affairs ever since. Some two or three years ago the matter was brought up at a meeting of the American Association, and the formation of a national chemical society, with headquarters at Washington, was advocated. This did not, however, meet the views of all; and a proposal is now made that the American Chemical Society shall be resuscitated, and that the meetings shall be held in conjunction with the meetings of the American Association for the advancement of Science. A committee has been appointed to consider this matter at the Toronto meeting, and delegates from the American Chemical Society and from the chemical section of the Franklin Institute have been appointed.

CLARK UNIVERSITY.

CLARK UNIVERSITY was founded by the munificence of a native of Worcester County, whose plans, conceived more than twenty years ago, have gradually grown with his fortune. His affairs have been so arranged as to allow long intervals for travel and study. During eight years thus spent, the leading foreign institutions of learning, old and new, were visited, and their records gathered and read. These studies centred about the means by which the highest culture of one generation is best transmitted to the ablest youths of the next, and especially about the external conditions most favorable for increasing the sum of human knowledge. To the improvement of these means and the enlargement of these conditions, the new university will be devoted.

It is the strong and express desire of the founder that the highest possible academic standards be here forever maintained; that special opportunities and inducements be offered to research; that to this end the instructors be not overburdened with teaching or examinations; that all available experience, both of older countries and our own, be freely utilized; and that new measures, and even innovations, if really helpful to the highest needs of modern science and culture, be no less freely adopted; in fine, that the great opportunities of a new foundation in this land and age be diligently explored and improved.

He has chosen Worcester as the seat of the new foundation after mature deliberation, first, because its location is central among the best colleges of the East, and, by supplementing rather than duplicating their work, he hopes to advance all their interests, and to secure their good will and active support, that together further steps may be taken in the development of superior education in New England; and, second, because he believes the culture of this city will insure that enlightened public opinion indispensable in maintaining these educational standards at their highest, and that its wealth will insure the perpetual increase of revenue required by the rapid progress of science.

As the first positive step towards the realization of these long-formed plans, Mr. Clark invited the following gentlemen to constitute with himself a board of trustees: Stephen Salisbury, Charles Devens, George F. Hoar, William W. Rice, Joseph Sargent,¹ John D. Washburn, Frank P. Goulding, and George Swan.

¹ Died Oct. 12, 1888.

A charter was granted early in 1887. Land and other property that had been before secured by the founder was transferred to the board, and the erection of a central building was begun.

In the spring of 1888, G. Stanley Hall, then a professor at the Johns Hopkins University, was invited to the presidency. The official letter conveying this invitation contained the following well-considered and significant expression of the spirit animating the trustees: "They desire to impose on you no trammels; they have no friends for whom they wish to provide at the expense of the interests of the institution, no pet theories to press upon you in derogation of your judgment, no sectarian tests to apply, no guaranties to require save such as are implied by your acceptance of this trust. Their single desire is to fit men for the highest duties of life, and, to that end, that this institution, in whatever branches of sound learning it may find itself engaged, may be a leader and a light."

The president was at once granted one year's leave of absence, with full salary, to visit universities in Europe. This year was diligently improved, and a report of its work will be made later.

The plans of the university have now so far progressed that work will begin in October next, in mathematics, physics, chemistry, biology, and psychology. These departments are provisionally arranged below in the order, not of prominence or completeness with which they will be organized at the opening, but only in the order of fulness with which announcements are now ready.

The president of the university has been appointed temporary professor of psychology, and will continue, so far as other engagements will permit, to direct the work of this department as formerly at the Johns Hopkins University. By instruction or seminars, or by careful personal conference and guidance to the best literature, and with the aid of Dr. Sanford, attention will be directed to the following topics: the general properties of the nervous substances; the psycho-physiology of each of the special senses and their defects; the perception of time and space; the time-sense; the psycho-physic law; mental images (morbid and normal) and their associations; the leading topics in the psychology of insanity, especially aphasia, illusions and hallucinations, melancholia, neurasthenia, epilepsy, hysteria, mania, and paralysis; instinct; the psychology of language; myth, custom, and belief anthropologically considered; hypnotism, and the psychological side of the history of philosophy, especially the Greek, German, and English systems. Dr. Hall will also direct the work of a few students of Class III. (below) in the history, methods, and organization of education, elementary, intermediate, and superior. On these topics he will give a special course of lectures during a part of the year.

Opportunities in psychology will be supplemented by work in the biological department, and especially by that of Dr. Donaldson. A well-equipped laboratory of apparatus for research in the various departments of experimental psychology will also be opened in October.

Opportunities for prompt publication of meritorious investigations, together with digests of current literature in this department, will be found in *The American Journal of Psychology*, which is published under the editorial care of Dr. Hall.

Henry H. Donaldson has been appointed assistant professor of neurology. Dr. Donaldson was graduated from Yale College in 1879. After spending a year at the Sheffield Scientific School and another at the College of Physicians and Surgeons in New York City, he was appointed a fellow of Johns Hopkins University for two years, receiving the degree of doctor of philosophy there in 1885. A year and a half was then spent in Europe, chiefly with Professors Guden at Munich, Forel at Zurich, and Golgi at Turin, and on returning he was appointed associate in psychology in the Johns Hopkins University.

Dr. Donaldson will give instruction in the finer anatomy of the central nervous system in man, in the histology of the sense-organs in the vertebrate series, and the localization of function in the brain, together with such other topics as may serve to facilitate study in these lines.

Those desiring further information concerning leading works of reference, or the equipment of the laboratory, can address Dr. Donaldson during the summer at Worcester.

Edmund Clark Sanford, who has been appointed instructor in psy-

chology, was graduated from the University of California in 1883. He has since spent four years at the Johns Hopkins University, where he was appointed fellow in psychology in 1887, and received the degree of doctor of philosophy the following year. The past academic year has been spent as instructor in the undergraduate department of the Johns Hopkins University, and in editing, under Dr. Hall's supervision, *The American Journal of Psychology*.

Dr. Sanford will give the two following special courses: First half-year, the physiological psychology of vision; monocular vision, color-perception, contrast, etc.; binocular vision, stereoscopy, and the horopter; perception of space, nativism, and empiricism. Chief authorities, Helmholtz, Hering, Wundt. The aim will be to demonstrate all the important experiments mentioned in the course, with suitable apparatus. Second half-year, the application of time-measurements to psychology, simple and complicated re-action times, personal equation, association times, and time-sense.

Dr. Sanford will also assist Professor Hall in the work of instruction and in the direction of the psycho-physic laboratory, seminary, etc. It is hoped that fuller opportunities for the study of historical philosophy, logic, and ethics may eventually be offered.

The work of the psychological department is intended for the following classes of students: those who desire to teach philosophy in any or all of its departments; physicians or medical students who wish to become specialists in the treatment of insanity or of diseases with nervous complications; those who desire to study education professionally, and who are advised to give most of their energy to psychology, which is its chief scientific basis, pedagogy being a field of applied psychology.

Some of the special topics into which the work above naturally falls can be attended as a special course by students of other departments. Thus students of biology or pathology may follow the histological course of Dr. Donaldson; students of classics may follow the course in Greek philosophy; of morphology, the lectures on instinct; of astronomy, the lectures on re-action time and the personal equation.

In the department of biology, Warren P. Lombard was appointed assistant professor of physiology in August, 1888. Dr. Lombard was graduated from Harvard College in 1878, and from Harvard Medical School in 1881. In 1881-82 he was prosector and lecturer in the College of Physicians and Surgeons in New York City, and for the next three years, 1882-85, attended lectures and was engaged in research work in Germany, chiefly in the laboratory of Professor Ludwig in Leipzig. The next three years were devoted to research and to the duties of lecturer and assistant in physiology at the College of Physicians and Surgeons, and elsewhere. The present year is being spent in the laboratories of Professors Dastre and Darsonval of Paris, Professor Mosso of Turin, and elsewhere. Work in this department will be conducted with the aid of lectures, laboratory, conferences, etc., and will cover the physiology of digestion, secretion, respiration, circulation, the nerves, muscles, and senses. The laboratory will be well furnished with instruments and other appliances for investigation in each of these special fields.

F. Mall has been appointed adjunct professor of anatomy. Dr. Mall was graduated from the University of Michigan in 1883, where he received the degree of M.D. He studied one year with Professor Kuhne at Heidelberg, and two years with Professors Weigert, His, and Ludwig in the University of Leipzig. Since 1886 he has been successively fellow, instructor, and associate in pathology, in the Johns Hopkins University. Dr. Mall will offer two courses, — one in histology, and one in vertebrate embryology.

Albert A. Michelson has been appointed acting professor of physics. Dr. Michelson was graduated at the United States Naval Academy in 1873, where he afterwards served as instructor in physics and chemistry for four years. He was later attached to the Nautical Almanac Office in Washington. For two years, beginning in 1880, he worked in Europe under Helmholtz, Quincke, Mascart, and Cornu. On returning, he resigned his commission of master (now called lieutenant) in the navy, and became professor of physics in the Case School of Science, Cleveland, O., where he has since remained. In 1888 he was awarded the Rumford medals for his researches on the velocity of light. Dr. Michelson

is a member of the American Academy of Science, corresponding member of the British Association, vice-president of the American Association for the Advancement of Science, etc.

Professor Michelson will give a course of illustrated and experimental lectures in physics, extending through two years. These will treat the chief topics in this department, and will be sufficiently advanced for students intending to make physics a specialty, and will be interspersed by examinations and conferences. This course will be supplemented by a series of lectures or readings in theoretical optics, electricity, and magnetism, or in thermodynamics of a more informal nature. Students with a fair knowledge of integral and differential calculus will have no difficulty in following this course.

A graded course of laboratory instruction will be offered for practical acquaintance with special methods. Dr. Michelson will strive, by advice and example, to encourage a spirit of diligent investigation and original research, particularly in those intending to find their life-work in this department.

The organization of no department will probably be more complete in October than that of chemistry. A large laboratory of about fifty rooms will be ready for occupation, and the names of some of the instructors can be very soon announced. Appliances for the department of mathematics are also liberally ordered. The names of instructors will soon be announced.

The organization of all the above and other departments will be gradual, and the foundation period of the university will cover some years. Apparatus is being extensively ordered of the best makers in this country and in Europe, chiefly from those who devote themselves to the special class of apparatus in which they excel.

Besides field-work, excursions to institutions public and private, coaching and cram classes, examinations, conferences, and other modes by which knowledge now seems best imparted and retained, the following educational methods will probably be prominent:—

Seminaries.—These are stated, perhaps weekly, meetings, often in a department library, for joint, systematic, but conversational work, under the personal direction of the professor, in some special chapter of his subject. Here the results of individual reading are reported for the benefit of all; views are freely criticised; new inquiries, methods, comparisons, standpoints, etc., suggested. From the mutual stimulus thus given, many important works have proceeded; and the efficiency of universities, especially in Germany, where seminaries were first generally introduced, has been greatly increased.

Laboratory Work.—For beginners, this was from the first the best of all forms of apprenticeship, bringing student and professor to a far closer and mutually stimulating relation. Here the manipulation of apparatus is learned, each well-chosen piece of which is an obvious epitome of long lines of research, processes are criticised, results obtained by other investigators are tested, methods are discussed and perfected. The modern laboratory has thus become an unexcelled school of logical mental discipline, from which is developed, as its best product, that rare independence in research which is the consummation of scientific culture.

Lectures.—The trustees desire that each instructor, of however few students, should prepare and deliver regular lectures, with diagrams, illustrative apparatus, and references to standard text-books and the best current literature upon each topic. Advanced students and instructors will also be encouraged to supplement the work of the professors by giving special lectures and courses. Public lectures will from time to time be given.

The following classes of students will be admitted:—

I. *Independent Students.*—This class will include those who have already taken the doctorate or other academic degrees in this country or abroad, and others of sufficient training who have time that may be devoted to particular lines of study or research. For competent men of this class, individual arrangements may be made and an independent room, and even special apparatus and books, provided, that they may pursue their investigations, either alone or with the aid and counsel of the instructors, to the best advantage. Conditions under which a few of the most advanced students of this class can be granted the *venia docendi*, as lecturers or docents, are under careful consideration. It is hoped that some of the per-

manent instructors of the university may be recruited from this class. It is probable that a few of these mature students can be received, not only in the five departments named above, but in others soon to be organized, and in the development of which they may co-operate.

II. *Candidates for the Degree of Doctor of Philosophy.*—Those qualifying for this degree will be matriculated early in the fall, after suitable tests, which will also aid in determining when they can be admitted to the final examination. The full course provided for this class of students will be three years, but admission to advanced standing at the outset is possible; and those found to be qualified may be allowed to take the doctor's examination in two years, or even one. It is to the needs of these students that the lectures, seminaries, laboratories, and collections of books and apparatus will be especially shaped, and no pains will be spared to afford them every needed stimulus and opportunity. It is for them that the fellowships and scholarships are primarily intended, although any of these honors may be awarded to students in Classes I. or III.

III. *Special Students not Candidates for a Degree.*—This class includes those who may desire to devote themselves exclusively to one or more of the special branches, — mathematics, physics, chemistry, biology, or psychology, — but who do not care to matriculate, or become candidates for a degree. These students, provided they satisfy the heads of departments of their training and competency in one subject, in which they must be advanced (although they may be less so, or even beginners, in other subjects), may be allowed entire freedom in their choice and combination of studies, and, as special students, may enjoy all the privileges of the university.

IV. *Medical Students.*—The university offers special facilities in those fundamental disciplines upon which the study of medicine in all its departments now rests. Thus, students of sufficient preliminary training can be admitted in the departments of chemistry, biology, anatomy, physiology, and neurology, and receive here the purely scientific part of a medical education.

V. *Preliminary Candidates or Undergraduates.*—Non-university students of less special or less advanced standing than the above four classes, who are nearly but not quite qualified to become candidates for the degree of doctor of philosophy, may also be received. Students of this class must for the present have completed the work of the first three, or at least of the first two, years of a regular undergraduate course in a college of good standing, or the equivalent thereof. They must satisfy the authorities of the university that they can proceed to the degree of A.B. in one year, and contemplate advancing to a higher degree. The privileges and status of these students will be more fully defined later. They may be elected to scholarships, but not to fellowships.

To no form of educational gift or bequest have probably so many people contributed as to the various forms of individual aid to meritorious students. Under the names of bursaries, stipends, exhibitions, prizes, benefices, etc., as well as of scholarships and fellowships, the revenues of foundations established by and bearing the names of sometimes hundreds of donors in a single university, are annually distributed.

Sometimes these funds were given by men or women themselves, not far removed from need, and are appointed to furnish a student with firewood, a room, a bed, one daily meal, or a coat each year, etc., and sometimes yielding one or two thousand dollars to a single holder. Often many students were provided by a single donor, and some of these European foundations, even the smallest, are centuries old, so sacredly are they guarded, and others are even now being established. The more advanced the education, the more such aids are needed, and the more numerous and substantial do they in fact become in Europe.

So great is now the need of bringing the best intellects to fullest maturity, and so increasingly necessary for the highest scientific attainment are now the leisure, tranquillity, books, and apparatus thus best supplied, that the demand is strong for still more and greater aids of this kind for advanced and competent students.

Several of the wisest governments in Europe, recognizing that the modern world and its rulers are ruled by experts thus best trained, vie with private munificence in supplying such aids. With a deep sense of the peculiar needs of our country in this respect,

the founder of this university, and his wife, have provided such opportunity and incentive here as follows:—

In addition to all previous gifts of the donor, and apart from the permanent funds of the university, full tuition of two hundred dollars each for thirty meritorious students will be paid into the treasury. For eight of these students, thus freed from tuition, Mr. Clark has also established fellowships yielding each holder four hundred dollars per annum, and eight more fellowships yielding each holder two hundred dollars per annum. These, with eight free scholarships as above provided, will be known as the "Jonas G. Clark Scholarships and Fellowships" respectively. Mrs. Clark has established two fellowships yielding four hundred dollars each, and two fellowships yielding two hundred dollars each, per annum. These, with the two remaining scholarships, will be known as the "Mrs. Jonas G. Clark Fellowships and Scholarships" respectively. These six latter are especially provided for the department of psychology, while the twenty-four presented by Mr. Clark are to be distributed among the other four departments at the discretion of the president and faculty.

The founder and his wife unite with the trustees and president in inviting sympathy and practical co-operation in the multiplication of such aids, large or small, temporary or permanent, here at the outset. Both scholarships and fellowships are open only to students in one or more of the five departments announced, and are renewable annually. They are designed to encourage promising young men, graduates of colleges and others, who have developed a preference for particular lines of study in which they desire to attain still further proficiency.

While intended to remove pecuniary hinderances in the way of such students, both scholarships and fellowships are primarily honors, awarded without reference to pecuniary needs. Thus, those desiring to do so may relinquish the emolument, and retain the title of scholar and fellow.

A plain, substantial, and well-appointed central building, 204 by 114 feet, four stories high, and with superior facilities for heating, lighting, and ventilation, has been constructed of brick and granite, and finished throughout in oak. A chemical laboratory, designed after consulting many experts and plans of recent European buildings, and containing about fifty rooms, is nearly completed. The foundations of a still larger department building are laid.

The work of instruction will begin in the five departments above announced, on Wednesday, Oct. 2, 1889.

TO PREVENT CONSUMPTION.

DRS. PRUDDEN, BIGGS, AND LOOMIS, pathologists to the Board of Health of the city of New York, having been requested to formulate a brief and comprehensive statement regarding the contagiousness of tuberculosis and the means of protection therefrom, have submitted the following:—

The disease known as tuberculosis, and, when affecting the lungs, as pulmonary tuberculosis (consumption), is very common in the human being, and in certain of the domestic animals, especially cattle. About one-fourth of all deaths occurring in the human being during adult life are caused by it, and nearly one-half of the entire population at some time in life acquires it. The disease is the same in nature in animals and in man, and has the same cause.

It has been proved beyond a doubt that a living germ, called the "tubercle bacillus," is the cause, and the only cause, of tuberculosis. It does not seem necessary to state the facts upon which this assertion is based, for the observation first made by Robert Koch in 1882 has been confirmed so often and so completely that it now constitutes one of the most absolutely demonstrated facts in medicine.

Tuberculosis may affect any organ of the body, but most frequently first involves the lungs. When the living germs find their way into the body, they multiply there, if favorable conditions for their growth exist, and produce small new growths or nodules (tubercles), which tend to soften. The discharges from these softened tubercles, containing the living germs, are thrown off from the body. In pulmonary tuberculosis these discharges constitute, in part, the expectoration. The germs thus thrown off

do not grow outside the living human or animal body, except under artificial conditions, although they may retain their vitality and virulence for long periods of time, even when thoroughly dried. As tuberculosis can only result from the action of these germs, it follows, from what has just been said, that, when the disease is acquired, it must result from receiving into the body the living germs that have come from some other human being or animal affected with the disease.

It has been abundantly established that the disease may be transmitted by meat or milk from the tubercular animal. The milk-glands in milch cows often become affected with the disease when their lungs are involved, and the milk from such animals may contain the living germs, and is capable of producing the disease. Among stall-fed dairy cows, 20 per cent or 30 per cent are sometimes found to be affected with the disease. Tubercular animals are also frequently killed for food, their flesh sometimes containing the germs, and, if not thoroughly cooked, it is capable of transmitting the disease. Boiling the milk, or thoroughly cooking the meat, destroys the germs. Although the meat and milk from tubercular animals constitute actual and important sources of danger, the disease is acquired, as a rule, through its communication from man to man.

Tuberculosis is commonly produced in the lungs (which are the organs most frequently affected) by breathing air in which the living germs are suspended as dust. The material which is coughed up, sometimes in large quantities, by persons suffering from consumption, contains these germs, often in enormous numbers. This material, when expectorated, frequently lodges in places where it afterward dries, as on the streets, floors, carpets, clothing, handkerchiefs, etc. After drying, in one way or another, it is very apt to become pulverized, and float in the air as dust.

It has been shown experimentally that dust collected from the most varied points in hospital wards, asylums, prisons, private houses, etc., where consumptive patients are present, is capable of producing tuberculosis in animals when used for their inoculation. Such dust may retain for weeks its power of producing the disease. On the other hand, dust collected from rooms in institutions or houses that have not been occupied by tubercular patients does not produce the disease when used for the inoculation of animals.

These observations show, that, where there are cases of pulmonary tuberculosis, under ordinary conditions the dust surrounding them often contains the "tubercle bacilli," and persons inhaling the air in which this dust is suspended may be taking in the living germs. It should, however, be distinctly understood that the breath of tubercular patients, and the moist sputum, received in proper cups, are not elements of danger, but only the dried and pulverized sputum. The breath and moist sputum are free from danger, because the germs are not dislodged from moist surfaces by currents of air. If all discharges were destroyed at the time of exit from the body, the greatest danger of communication from man to man would be removed.

It then follows, from what has been said, that tuberculosis is a distinctly preventable disease. It is a well-known fact that some persons, and especially the members of certain families, are particularly liable to tuberculosis; and this liability can be transmitted from parents to children. So marked and so frequent is this liability, and so frequent is the development of the disease in particular families, that the affection has long been considered hereditary. We now know that tuberculosis can only be caused by the entrance of the germ into the body, and that this transmitted liability simply renders the individual a more easy prey to the living germs when once they have gained entrance.

The frequent occurrence of several cases of pulmonary tuberculosis in a family is, then, to be explained, not on the supposition that the disease itself has been inherited, but that it has been produced after birth by transmission directly from some affected individual. Where the parents are affected with tuberculosis, the children, from the earliest moments of life, are exposed to the disease under the most favorable conditions for its transmission; for not only is the dust of the house likely to contain the bacilli, but the relationship also between parents and children, especially between the mother and child, is of that close and intimate nature especially favorable for the transmission by direct contact.

If, then, tuberculosis is not inherited, the question of prevention resolves itself principally into the avoidance of tubercular meat and milk and the destruction of the discharges, especially the sputum of tubercular individuals. As to the first means of communication, those measures of prevention alone answer the requirements which embrace the governmental inspection of dairy cows and of animals slaughtered for food, and the rigid exclusion and destruction of all those found to be tubercular.

For the removal of the second means of communication, i.e., the sputum of tubercular individuals, the problem is simple when the patients are confined to their rooms or houses. Then, wooden or pasteboard cups, with covers, should always be at hand for the reception of the sputum. These cups are supported in simple racks, and at least once daily, or more frequently if necessary, should be removed from the racks and thrown with their contents into the fire. A cheap and efficient cup answering this purpose is now on the market, and is supplied by the druggists.

The disposition of the expectoration of persons who are not confined to their rooms or homes is a far more difficult problem. The expectoration certainly should not be discharged on the street, and the only practicable means for its collection seems to be in handkerchiefs, which, when soiled, should at the earliest possible moment be soaked in a solution of five per cent carbolic acid, and then boiled and washed. Handkerchiefs thus soiled are exceedingly dangerous factors in distributing tubercle bacilli; for, when the sputum becomes dry, it is easily separated in flakes from the cloth, and then soon becomes pulverized and suspended as dust.

It becomes evident from what has been said that the means which will most certainly prevent the spread of this disease from one individual to another are those of scrupulous cleanliness regarding the sputum. These means lie largely within the power of the affected individual. It is furthermore to be remembered that consumption is not always, as was formerly supposed, a fatal disease, but that it is in very many cases a distinctly curable affection.

An individual who is well on the road to recovery may, if he does not with the greatest care destroy his sputum, diminish greatly his chances of recovery by self-inoculation.

While the greatest danger of the spread of this disease from the sick to the well is in private houses and in hospitals, yet, if this danger is thoroughly appreciated, it is, for the most part, quite under control through the immediate destruction of the sputum and the enforcement of habits of cleanliness. But in places of public assembly, such as churches and theatres, particularly the latter, conditions are different, and the safety would seem to depend largely upon a dilution and partial removal of the floating and possibly dangerous dust by means of adequate ventilation.

Rooms in private houses and hospital wards that are occupied by phthisical patients should from time to time be thoroughly cleaned and disinfected, and this should always be done after they are vacated before they are again occupied by other individuals. Steamship companies should be obliged to furnish separate apartments for consumptive persons, so that no person in the exigencies of travel need be forced to share his room with one who might be a source of active danger to him.

Drs. Prudden, Biggs, and Locomis desire especially to emphasize the following facts: (1) that tuberculosis is a distinctly preventable disease; (2) that it is not directly inherited; and (3) that it is acquired by the direct transmission of the tubercle bacilli from the sick to the healthy, usually by means of the dried and pulverized sputum floating as dust in the air.

The measures, then, which are suggested for the prevention of the spread of tuberculosis are (1) the security of the public against tubercular meat and milk, attained by a system of rigid official inspection of cattle; (2) the dissemination among the people of the knowledge that every tubercular person may be a source of actual danger to his associates if the discharges from the lungs are not immediately destroyed or rendered harmless; and (3) the careful disinfection of rooms and hospital wards that are occupied or have been occupied by phthisical patients.

THE annual meeting of the American Climatological Society will be held in Boston, June 24 and 25; Dr. V. L. Bowditch of Boston, president.

SIXTH ANNUAL REPORT OF THE SUPERINTENDENT OF HEALTH OF PROVIDENCE.

In this report, Dr. Charles V. Chapin, the superintendent of health, records many important facts and observations. The number of deaths reported was 2,608. The population of the city being 121,500, this gives a death-rate of 21.48 per thousand. From consumption there were 359 deaths, an increase of 46 over 1887: 10.39 per cent of all deaths were from diarrhœal diseases. Malarial fever first appeared in Providence in 1880, when one death was reported from that cause. Since that time 92 deaths have occurred from that cause: 9 in 1885, 11 in 1886, 26 in 1887, and 19 in 1888. The disease is confined almost entirely to certain well-defined districts of the city, which are particularly exposed to those influences which have been conclusively shown to be the chief causes of the production of the malarial poison. But 2 deaths occurred from measles, while there were 28 from whooping-cough. There were no deaths from small-pox: indeed, there has been but one death from that disease in Providence since 1875.

Dr. Chapin, in this report, deals specially with two forms of contagious disease, — scarlet-fever and typhoid-fever, — and it is to these two subjects that we shall mainly devote our attention. In writing of scarlet-fever, he says, "Scarlet-fever is one of those contagious diseases which tend to recur in epidemics at more or less regular intervals. Since 1840 there have been ten epidemic periods, separated by intervals of about five years. As is usual with the disease in this part of the world, these epidemics generally have begun in the autumn, and increased in severity until late in the winter or spring. One of these epidemics, though not a severe one either as regards the number of cases or the mortality, began in August, 1884, attained its maximum in November, and was pretty well over by early spring. In 1887 another epidemic occurred, beginning in August.

"During the epidemic of 1884, some efforts were made by this department, chiefly by regulating school-attendance, to check its spread, but apparently without any very great influence. The rapid onset of the disease in the autumn of 1887 so attracted the attention of the public, that it was deemed feasible to adopt more stringent measures. While it cannot be definitely proved that the marked falling-off in the cases and deaths from this disease which immediately followed the adoption of more stringent measures was due to this, yet it is rendered highly probable from the fact that such a decrease in scarlet-fever at that time of the year is markedly at variance with the usual course of the disease in Providence, and indeed in all cities in this climate. Though there is no theoretical reason why scarlet-fever, being a purely parasitic disease, should not be entirely stamped out, yet we can never hope to accomplish this, so long as the public, and physicians also, are as careless about it as they are at the present day. While in the majority of cases, except among the very poor pretty fair isolation is maintained at first, it is not kept up long enough, and children are often allowed to ride in the horse-cars, go to Sunday-school, or visit a clothing store and try on half a dozen different coats, by the end of the third week, and before they have ceased to peel; and the most discouraging thing about it is, that it is often done with the consent of the attending physician. It must, I am afraid, be the duty of the health department to insist upon the contagious nature of this disease for many years to come, and, while striving not to render its rules inoperative by reason of their being too far in advance of public sentiment, strive, whenever opportunity offers, to make them more and more stringent.

"It is popularly believed that nearly every person will have scarlet-fever sooner or later; and I very frequently see persons who say they had rather let their children catch scarlet-fever while they are young, as it would go so much harder with them when they grow up. But such a belief is totally without foundation. During the past five years there were reported about 2,300 cases of scarlet-fever. If we assume that this rate has been continuous for the last fifteen years, then there have been only a little over 7,000 cases of scarlet-fever during that time. If we approach the problem in another way, and take the deaths during the last fifteen years, and assume the mortality to have been ten per cent, which is certainly low, the number of cases during this time is 13,970, or, in

round numbers, 14,000. The total number of children in the city under fifteen years, at the census of 1885, was 34,592; it must now be at least 36,000. Therefore, if we assume that the general death-rate of those who have had scarlet-fever is the same as those who have not, and the same relative figures are true for those who have moved into the city, there must, by the most unfavorable estimate, be one and one-half persons of fifteen years of age living in Providence who have not had scarlet-fever to every one that has. Or if we take the more favorable estimate, which I think is nearer the truth, there are at present four persons of that age who have not had scarlet-fever to every one that has. The age of fifteen is selected because scarlet-fever is rare after that; for, out of nearly a thousand cases in this city, there were only twenty-four over fifteen. The chance, then, of a child's growing up without having scarlet-fever, is even now very good. It can be made still better by a proper observance of sanitary rules. In four cases where children who had been removed at the inception of the disease were taken sick on their return, they were absent from four to five weeks, and were attacked within two or three days after their return. In the other cases the absence continued for from four to six weeks in the majority, but was less than that in some instances, and greater in others. We may, I think, fairly infer from them, that, when a child is exposed to scarlet-fever in its own family, its chances of escaping or contracting the disease are about even. The figures also show that when not brought in such intimate contact, but when merely a resident of the same house but in another tenement, the chance of contracting the disease is much less, being in fact one in seven. The recognition of this fact has made me somewhat more lenient than formerly in excluding children from school. In houses where I am satisfied that there is no direct communication between the families, I only exclude those children in the family in which disease actually exists, allowing the other children in the house to continue their attendance. Of course, where there is any doubt about the children mingling, as there always is in the crowded tenements of the poorer classes, it is necessary to exclude all in the house.

"In regard to fumigation, it is seen, that, in the 114 cases where fumigation with sulphur was done as well as it could be in a private house, the disease extended beyond the family where it first appeared, to others in the house, ten times. This is less often than when fumigation was not done, the ratio then being about one to four, and in the latter case one to eleven. But how much credit is to be given to the fumigation for this, I do not know. When people attend to fumigation properly, they usually are careful about isolation also, and the disinfection of soiled linen, etc., and they are also more thorough in the application of inunction; and it is probable that all these things have as much or more to do with the restriction of the disease than does the final fumigation."

Dr. Chapin speaks doubtfully of inunction of the skin as a preventive of the spread of scarlet-fever. In cases where it was practised, out of 714 susceptible children in families where the disease existed, 467 were attacked, which is a larger proportion than where it was not done. This method was proposed by Dr. Jamieson, and has given good results in Great Britain. Its failure in Providence may be due to its improper performance, or the neglect of parents to continue it long enough.

The number of deaths from typhoid-fever during the first eleven months of 1888, while in excess of the preceding year, was not much above the average for the past few years. The autumn was warm and rainy, and it was thought that the slight increase in this disease might be due to these meteorological conditions. During the last week in November, however, the disease increased greatly and suddenly, and almost as suddenly diminished during the early part of December. During the two weeks ending Dec. 15, 223 cases of typhoid-fever were reported at the superintendent's office, 139 being reported during the week ending Dec. 8. This is the largest number ever reported in one week, except during the epidemic of 1882, when 163 cases were reported during the week ending Nov. 11. The number of deaths in December from typhoid-fever was 47, which has been exceeded only once, by 70 deaths in November, 1882. The next largest number of deaths was 32, in April, 1883. It will thus be seen that the epidemic, though short, was severe.

For this outbreak there must have been some peculiar and local exciting cause. General meteorological conditions must be excluded, for they would have operated over the neighboring country as well as in Providence. There was, it is true, a very heavy rainfall during the year 1888, and particularly in November, and the season was unusually mild; but a local epidemic like this cannot properly be attributed to any such general influences. The cases were scattered very generally and very equally over the city. The only district which had less than its due proportion was that on the summit of the hill on the east side of the Providence River. Local unsanitary conditions, acting only on the individuals attacked, could not stand in a causative relation, as is shown by the report of the medical inspector.

The one cause which seemed most likely to act upon the whole city for the production of this disease was the water-supply. A quite common and absolutely demonstrated cause of typhoid-fever is the pollution of drinking-water with the stools of typhoid patients. Knowing the danger of pollution to which the Pawtuxet River was exposed, and thinking that the source of trouble might possibly be found along its banks, Dr. Chapin proceeded to make a thorough investigation of the river-valley. From inquiries he learned, that, with the exception of one locality, there had been only two or three recognized cases of typhoid in the valley of the river during the autumn months. The exception was at Natick, Below Natick, at Pontiac, is a dam. This is the only obstruction between the pumping-station and Natick. At the latter place are several tenements belonging to the Mill Company, situated from one hundred to one hundred and twenty-five feet from the river-bank on a flat only a few feet above the level of the water. These houses are occupied by French Canadians, and it was among them that the typhoid-fever occurred. The attending physicians — one of Natick, and the other of Centreville — could not state how this epidemic originated, but they assured Dr. Chapin that during the months of September, October, and November there had been about twenty cases of the disease in these houses, and that one or two of the patients were only just convalescent when he visited the village on Dec. 7. These people were ignorant, and no information could be gained by questioning them. They were very careless and filthy in their habits; and the attending physician stated, that, as was to be expected, they made no pretence of disinfecting the excreta of the patients. These houses were all provided with water-tight cemented vaults, situated within fifteen to twenty-four feet of the water's edge, which had not been cleansed for two or three months previous to Dec. 1, and no night-soil had been applied to any land near the river during that time.

Openings had been left in the covers of the vaults, through which it was supposed that the tenants would empty their slops; but the people chose, perversely, to throw them on the ground behind and at the side of the privies. Places were seen on the banks of the stream where these slops, mingled with fecal matter, were slowly working their way into the water. Cases of typhoid began to appear with unusual frequency in Providence about Nov. 23. As there are good reasons for believing that the incubation of typhoid-fever consumes from ten to eighteen days, and as two or three days might elapse before the disease poison was distributed at the house-taps, it is evident that the course of events was as it would have been if the rain of the 9th of November had washed the specific poison into the water.

Examinations were made of the water itself, taken from the distribution in the city, the river, and the two reservoirs. The bacteriological investigations of Dr. Swarts, the medical inspector, have made it certain that the house-filters in common use collect filth and microbes from the water, and act as incubators for the latter, allowing them to rapidly propagate within the interstices of the filtering material, and they are washed out in large numbers as water is drawn through the filter. Such filters have been invariably condemned; for it seemed certain, that, in case there were disease-germs in the water, the so-called filters, instead of removing them, would actually increase the amount of the poison, and so increase the liability to disease in those who use them. During this epidemic a large number of patients were found who had used water thus filtered; and it was especially noticeable that many of the cases which occurred soon after the epidemic proper had

ceased, made use of filters, and it is highly probable that the poison was preserved and increased in amount in these filters.

It was determined to examine these filters (taken from houses where there was typhoid) to learn whether or not they contained the specific organism. As the labor of examining such an enormous number of organisms as were found in the filters is very great, only a few filters were tested. Dr. Swarts examined some, and some were sent to Dr. T. Mitchell Prudden of the College of Physicians and Surgeons, New York, and others to Dr. Harold E. Ernst of Harvard, — all gentlemen thoroughly skilled in bacteriological work. It must be remembered that all these filters were found to be filled with decomposing organic matter, and swarming with countless bacteria. The isolation of one particular species among so many is a task of extreme difficulty, and negative testimony is of little value. Even the most skilled observers abroad have failed to detect this particular organism under similar conditions, although it was known to be certainly present. In the investigations made for this department the organism which produces typhoid-fever was not found in the water itself. Bi-monthly analyses of the water to determine the number of organisms were made on the 1st of December; but, as only a few plate-cultures were made, the negative result obtained can have little value, yet, as the epidemic was rapidly diminishing by the end of the first week in December, it is probable that there were no typhoid organisms in the water itself at the time the analyses were made. The typhoid organisms were, however, found in three of the filters. One of these filters came from the west side of the city, and the others from the east side (one from the northern, and the other from the southern part). None were on the high-service supply.

Filter No. 1, a "Star" filter, was removed from the tap Dec. 8. The patient was taken sick Dec. 1, and the filtered water had not been used for drinking-purposes since that time. There was a trap in the sink-pipe of the sink where the faucet was. There was no water-closet in the house, and the stools of the patient were disinfected and thrown into the vault. Filter No. 2, a "Grant" filter, was removed Dec. 6. The patient was taken sick Nov. 29, and died of hemorrhage Dec. 17. The plumbing of the house was complicated, but perfectly trapped and in good order. Filter No. 3, an "Aborn" filter, was removed Dec. 6. The patient was taken sick Dec. 1. The plumbing was in first-class condition; and the sanitary conditions of the house, one of the finest in the city, perfect.

There is no question that the patients who used these filters were suffering from true typhoid; and there was no chance for these filters, either while in position or after they were removed, to become contaminated, except from the water which passed through them. Besides the typhoid bacilli, several organisms characteristic of fecal matter were found in the filters, indicating the source of the specific contamination. In fact, one of the filters, so far as the organic life was concerned, resembled, as Dr. Prudden said, a mixture of charcoal, water, and human feces.

These investigations demonstrated the presence of the typhoid bacillus in our public water-supply, and also the dangerous character of the domestic filters in common use, and they also prove that the short epidemic of November and December last was due to the pollution of the Pawtuxet River by the stools of typhoid-fever patients.

BOOK-REVIEWS.

Mechanics of Engineering. [Fluids.] By IRVING P. CHURCH. New York, Wiley. 8°. \$3.

IN the preparation of this treatise on hydraulics and pneumatics, which is intended mainly for use in technical schools, the same general design has been kept in view as in the preparation of the preceding and companion work on solids. The author, who is assistant professor of civil engineering at Cornell University, has succeeded in combining clearness with consistency in the setting-forth and illustration of theoretical principles, and has provided numerous and fully lettered diagrams, in which, in the greater number of cases, the notation of the accompanying text can be easily apprehended. Especial attention is invited to the proper use of systems of units in numerical examples, the latter being introduced very copiously and with de-

tailed explanations. The results of the most recent experimental investigations in hydraulics have been taken advantage of in assigning values of the numerous co-efficients necessary to the more thorough comprehension of the subject. Among the investigations thus utilized may be mentioned those of Fteley and Stearns in 1880, and of Bazin in 1887, on the flow of water over weirs; those of Clemens Herschel in testing his Venturi water-meter; and also some recent experiments in the transmission of natural gas and compressed air. Though the action of fluid motors has not been dealt with as extensively as some might have desired, sufficient matter is given in treating of the mode of working steam, gas, and hot-air engines, air-compressors, and pumping-engines, together with numerous examples, to be of considerable advantage to students not making a speciality of mechanical engineering.

Elementary Synthetic Geometry of the Point, Line, and Circle in the Plane. By N. F. DUPUIS. London and New York, Macmillan. 16°. \$1.10.

THIS work is a result of the author's experience in teaching geometry to junior classes in the University of Queen's College, Kingston, Canada, for a series of years. It is not an edition of "Euclid's Elements," and has, in fact, little relation to that work except in subject-matter. There are a number of points in which the book varies from the majority of modern treatises on geometry. The point, the line, and the curve, lying in a common plane, are taken as the geometric elements of plane geometry, and any one of these or any combination of them is defined as a geometric plane figure. Thus, the author defines a triangle as the combination of three points and three lines, and he claims that this mode of considering geometric figures leads naturally to the idea of a figure as a *locus*. The principle of motion and the transformation of geometric figures recommended by Sylvester, and the principle of continuity, are freely employed.

The intention in preparing the work has been to furnish the student with that kind of geometric knowledge which may enable him to take up successfully the modern works on analytic geometry.

Go to the Ant and learn Many Wonderful Things. By JOHN WENTWORTH SANEORN. Cincinnati, Cranston & Stowe; New York, Hunt & Eaton. 12°.

MR. SANBORN, finding that his own children were interested in his experiments with ants, and that they asked him all sorts of questions, sought every possible means for gaining information to instruct them, and as a result of the notes put down by him from time to time, of the information gathered by observation and reading, this little book was prepared. The book tells of the social life of ants, their food, the plants which they seek, the different varieties of ants, with a chapter on foraging ants and ants as social creatures.

A Treatise on Spherical Trigonometry, and its Application to Geodesy and Astronomy. By JOHN CASEY. London and New York, Longmans, Green, & Co. 12°. \$1.50.

THIS manual is intended as a sequel to the author's treatise on plane trigonometry, and is written on the same plan. It is believed, that, though moderate in size, it contains a large amount of matter, much of which is original; the author having turned especially to *Crelle's Journal für die reine und angewandte Mathematik*, Berlin, and *Nouvelles Annales de Mathématiques*, Paris, for recent information. Professor Neuberg of the University of Liège aided considerably in its preparation.

A Laboratory Guide in Chemical Analysis. By DAVID O'BRINE. 2d ed. New York, Wiley. 8°. \$2.

THIS volume is intended for the use of students who possess some knowledge of chemistry, and is especially adapted to the wants of the college or the medical laboratory. In the second edition we note that some of the chapters which were in the first edition have in this been greatly extended, while others are entirely new. Among the items of special interest we would mention the separation of substances by electrolysis, water analysis, and the methods for the detection of ptomaines and alkaloids.

Publications received at Editor's Office,
June 3-8.

- BLAND, F. *The Prophet's Mantle*. Chicago, New York, and San Francisco, Belford, Clarke, & Co. 322 p. 12". 50 cents.
- CARUS, P. *Fundamental Problems. The Method of Philosophy as a Systematic Arrangement of Knowledge*. Chicago, Open Court Publ. Co. 267 p. 12". \$1.
- JOHNSON, W. E. *Treatise on Trigonometry*. London and New York, Macmillan, 504 p. 12". \$2.25.
- KERR, ALVA M. *Iran; or, The Mormon's Daughter*. Chicago, New York, and San Francisco, Belford, Clarke, & Co. 184 p. 12". 50 cents.
- NEW JERSEY, Annual Report of the State Geologist of, for the Year 1888. Camden, Sinnickson Chev, Pr. 86 p. 8".
- SAUVOUR, L. *Les Chansons de Béranger*. New York, Christern; Boston, Carl Schenbof. 228 p. 12".

Old and Rare Books.

One Million Magazines. Back numbers, vols. and sets—old and new, Foreign and American. CATALOGUE UPON APPLICATION.
A. S. CLARK,
34 Park Row, New York City.

BACK NUMBERS and complete sets of leading Magazines. *Rates low.* AM. MAG. EXCHANGE, Schoharie, N.Y.

Schools.

CONNECTICUT, NEW HAVEN.
MRS. CADY'S SCHOOL FOR YOUNG LADIES. Prepares for Smith and Wellesley, and admits to Vassar by Certificate. Circulars. Early application necessary.

NEW JERSEY, PLAINFIELD.
THE CHESTNUTS.—Parents with daughters to educate, or orphan girls with companion, may find a comfortable home, with school instruction by applying to Miss E. E. Kenyon.

Correspondence solicited with parties seeking publishers for scientific books.

N. D. C. HODGES,
Publisher of Science,
47 Lafayette Place,
New York.

READY THIS WEEK.

The Ice Age in North America,

AND ITS BEARINGS UPON THE ANTIQUITY OF MAN.

By G. Frederick Wright, D.D., LL.D., F.G.S.A., Professor in Oberlin Theological Seminary; Assistant on the United States Geological Survey.

With an Appendix on "The Probable Cause of Glaciation," by Warren Upham, F.G.S.A., Assistant on the Geological Surveys of New Hampshire, Minnesota, and the United States.

With 147 Maps and Illustrations. One vol., 8vo, 640 pages, cloth. Price, \$5.00.

The writer has personally been over a large part of the field containing the wonderful array of facts of which he is now permitted to write, but he is one only of many investigators who have been busily engaged for the past fifteen years (to say nothing of what had been previously accomplished in collecting facts concerning the glacial period in this country. His endeavor has been to make the present volume a fairly complete digest of all these investigations.

Although the title of the book is "The Ice Age in North America," it is really a treatise on the whole subject of the glacial period; for, with the vast field open for investigation on this continent and the amount of attention recently given to its exploration, North America is now by far the most favorable place from which to approach the study of ice action and ice periods.

The numerous maps accompanying the text have been compiled from the latest data. The illustrations are more ample than have ever before been applied to the subject, being mostly reproductions of photographs taken by various members of the United States Geological Survey in the course of the past ten years, many of them by the author himself.

D. Appleton & Co., Publishers,
1, 3, & 5 BOND STREET, NEW YORK.

MACMILLAN & CO.

PUBLISH THIS DAY:

Darwinism.

AN EXPOSITION OF THE THEORY OF NATURAL SELECTION, WITH SOME OF ITS APPLICATIONS. By Alfred Russel Wallace, LL.D., F.R.S., etc., author of 'The Malay Archipelago,' etc., etc. With Map, Portrait of the Author, and Illustrations. 12mo, cloth extra, \$1.75.

"The present work contains the conclusions upon this great subject of thirty years of thought and observation. . . . A contribution of the first importance to the literature of the subject. At the same time it would be difficult to find a book more entertaining to the general reader. He writes with the sincerity and easy mastery which comes of fullness of knowledge. There can be no more interesting guide in that great wonderland of science in which he has been so long one of the chief discoverers."—*New York Times*.

Nature Series—New Volumes.

THE CHEMISTRY OF PHOTOGRAPHY. By Raphael Meldola, F.R.S., Professor of Chemistry in the Technical College, Finsbury; City and Guilds of London Institute for the Advancement of Technical Education. Crown 8vo, \$2.00.

"We are delighted with the excellent arrangement and accuracy of the work. There is not, we are sure, a photographic practitioner—whether mainly technologist or essentially artist—who would not benefit largely by a careful study of Prof. Meldola's work."—*Photographic News*.

POPULAR LECTURES AND ADDRESSES. By Sir William Thomson, LL.D., F.R.S., F.R.S.E., &c., Professor of Natural Philosophy in the University of Glasgow, and Fellow of St. Peter's College, Cambridge. In 8 vols. With Illustrations. Crown 8vo. (Nature Series.) Vol. I. Constitution of Matter. \$2.00.

"The subjects of Sir William Thomson's 'Popular Lectures and Addresses' are of such deep interest, both theoretical and practical, and are treated in such a masterly manner that their republication in a collected form was only a question of time."—*Journal of Education*.

THE SCIENTIFIC PAPERS OF THE LATE THOMAS ANDREWS, M.D., F.R.S., Vice-President and Professor of Chemistry, Queen's College, Belfast. With a Memoir by P. G. Tait, M.A., Sec. R.S.E., and A. Crum Brown, M.D., F.R.S., Professors in the University of Edinburgh. 8vo. \$5.00.

"We have here in a compact form the biography and scientific works of a man who has left his mark on the science of his time. The various papers in this volume, and especially the presidential address, show Dr. Andrews to have been not only an accurate and original worker, but a man of wide culture and refined literary taste. The editors have done their work carefully and well."—*Nature*.

New Mathematical Works.

ELEMENTARY SYNTHETIC GEOMETRY OF THE POINT, LINE AND CIRCLE IN THE PLANE. By N. F. Dupuis, M.A., F.R.S.C., Professor of Pure Mathematics in the University of Queen's College, Kingston, Canada. 16mo, \$1.10.

A TREATISE ON GEOMETRICAL CONICS. In Accordance with the Syllabus of the Association for the Improvement of Geometric Teaching. By Arthur Cockshott, M.A., and the Rev. F. B. Walters, M.A. 16mo, \$1.25.

TREATISE ON TRIGONOMETRY. By W. E. Johnson, M.A. 12mo, \$2.25.

A TREATISE ON SPHERICAL TRIGONOMETRY. With Application to Spherical Geometry and numerous Examples. By William J. McClelland, M.A., and Thomas Preston, B.A. Second edition. Complete in one volume. 12mo, \$2.25.

MACMILLAN & CO., PUBLISHERS,
112 FOURTH AVENUE, NEW YORK.

Elementary Statics. By J. B. LOCK. London and New York, Macmillan. 16°. \$1.10.

THIS little book has been prepared as a text-book for students intending to present themselves for the Cambridge previous examination for Woolwich, for the Oxford and Cambridge certificate, and for other English examinations of a similar nature. The author has also endeavored to keep in view the importance of the subject as an introduction to the study of physics and of practical mechanics. A slight knowledge of trigonometry is needed, but considerable portions may be read without any acquaintance with this subject. The truth of the parallelogram of forces is assumed, and, like many English writers, the author bases the whole subject on Newton's laws of motion. A chapter is added on graphic statics, in which is considered the triangle of forces. The examples given are in general simple, but at the end one hundred examples of greater difficulty are inserted.

AMONG THE PUBLISHERS.

IN the first number of *The New Review*, which Longmans, Green, & Co. will issue at once, Senator Naquet, a partisan of Gen. Boulanger, states the general's case by authority, and is answered in the following pages by M. Camille Pelletan. Another burning question, "The Unionist Policy in Ireland," is discussed in the same number by T. W. Russell, M.P. Lady Randolph Churchill contributes to the June number of *The New Review*, notes of travel, called "A Month in Russia;" and another American, Mr. Henry James, supplies an article entitled "After the Play."

— Ward & Downey will publish shortly the first authentic narrative of the early proceedings of Stanley's expedition to relieve Emin Pacha, under the title of "With Stanley's Rear Column." The author, Mr. J. Rose Troup, who was the transport officer of the expedition, will give a full account of the experiences of the party left at Yambuya. His narrative will include a description of the voyage up the Kongo, the camp on the Aruvimi, and a complete diary, showing how events led up to the assassination of Major Bartelot, and the failure of this branch of Stanley's expedition.

— Messrs. Ginn & Co. announce for publication "Algebraic Analysis," by G. A. Wentworth, J. A. McLellan, and J. C. Glashan. This work, which has been previously announced as Wentworth & McLellan's "University Algebra," is intended to supply students of mathematics with a well-filled storehouse of solved examples and unsolved exercises in the application of the fundamental theorems

and processes of pure algebra, and to exhibit to them the highest and most important results of modern algebraic analysis. The work will be issued in two volumes, the first of which closes with an extensive collection of exercises in determinants.

— Cassell & Co. will publish on the 15th, Wilder's "The People I've Smiled With" and a cheaper edition of Max O'Rell's "Jonathan and his Continent."

— D. Appleton & Co. publish this week "The Ice Age in North America, and its Bearings upon the Antiquity of Man," by G. Frederick Wright, professor in Oberlin Theological Seminary, and assistant on the United States Geological Survey, with an appendix on "The Probable Cause of Glaciation," by Warren Upham.

— Houghton, Mifflin, & Co. have just published "The Beginnings of New England," a series of lectures by John Fiske; "Indoor Studies," a new volume of essays, by John Burroughs, chiefly on authors and literary subjects; and two new volumes in their Riverside Library for Young Folks, — "Birds through an Opera-Glass," by Florence A. Merriam; and "Up and Down the Brooks," by Mary A. Bamford. They will publish, in connection with Bickers & Son of London, an *édition de luxe* of Swift's works in nineteen volumes, octavo. Only 250 copies will be placed on the American market. The reprint is after Sir Walter Scott's second edition.

— *The Home Journal*, in its issue of June 12, publishes a summer-resort guide which contains facts of interest concerning summer hotels. The guide gives the features of the hotels, the number of guests each accommodates, with the tariff of charges, the distances, and how to reach the different points.

— Trübner & Co. will issue immediately the first number of a new periodical, *The Periodical Press Index*, a monthly record of leading subjects in current literature. Mr. John S. Farmer, the compiler, has indexed about 160 different publications in the first number. There will also be issued a yearly summary volume, which will include all that is contained in the twelve monthly numbers.

— The May number of the *Modern Science Essayist* (Boston) contains an essay on "The Descent of Man," by E. D. Cope, Ph.D. The June number is devoted to the "Evolution of the Mind," by Robert G. Eccles, M.D.

— Nos. VII., VIII., and IX. of the *Johns Hopkins University Studies* (seventh series) are devoted to "The River Towns of Connecticut, a Study of Wethersfield, Hartford, and Windsor," by Charles M. Andrews.

INDUSTRIAL NOTES.

New England Electric Company.

THE New England business of the Sprague Electric Railway and Motor Company of New York will hereafter be conducted by

The Detroit Fair.

A fair and exposition will be held in Detroit from Sept. 17 to 27. The above cut shows the building. Its dimensions are, height, 70 feet; length, 500 feet; depth, 250 feet; height of corner towers, 116 feet; height of main tower, 200 feet; exhibition space, 200,500

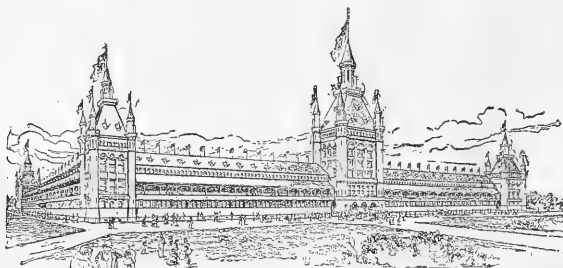

THE DETROIT FAIR BUILDING.

the New England Electric Company, with offices at 55 Oliver Street, Boston. Mr. F. J. Sawyer is president of the new company, and Mr. Edward Blake, treasurer.

square feet. The art building will contain 10,000 feet of exhibit surface. There will be stock stables and an agricultural field of fifteen acres.

GUARANTY INVESTMENT COMPANY

CAPITAL \$250,000.

Hon. ALBERT H. HORTON (Chief Justice, Kansas Supreme Court), Topeka, Kan., Pres't.

7% Guaranteed Farm Mortgages 7%

The Company calls the special attention of Investors to the following points :

- I. All loans guaranteed and interest payable semi-annually at the Importers' & Traders' National Bank, New York.
- II. Unusual fulness of information, not only about the security itself, but about the general development of the section where the farm is located.
- III. An examination each year of the general business of the Company and the Mortgages themselves by a COMMITTEE OF INVESTORS sent for the purpose.
- IV. Many hundred Mortgages taken and NOT A SINGLE FORECLOSURE.
- V. Exhibitions in New York at frequent intervals, of Kansas and Nebraska Farm Products. The Exhibition at the American Institute in the fall of 1888, received the *HIGHEST AWARD* of superiority.
- VI. Monthly Bulletins giving full information about all Mortgages offered for sale.

Address for Monthly Bulletin and Investors' Committee Report for 1888,

HENRY A. RILEY, General Eastern Manager, 191 Broadway, N.Y.

ESTABLISHED 1859.

H. A. DREW,
Commercial Printer,
5 Clinton Place, near Broadway,
New York.

Wedding Orders, Souvenirs, Invitations, Orders of Dance, etc., etc., done in the latest and most elaborate styles, at reasonable prices.

All Favors promptly attended to.

BLACK GOODS.

We are now offering the balance of our Brocade and Striped Black Grenadines from \$1.25 to \$3 per yard.

Especial attention is directed to a line of Mexican Grenadines, all silk, at 75 cents per yard; formerly \$1.50.

Also to Embroidered and Striped Black Crepe de Chine, from \$3 to \$6 per yard, and to a lot of Black Brocaded Mohairs, which we are closing out at 50 cents per yard.

All the above goods are of the best quality and in most desirable styles.

JAMES McCREERY & CO.
BROADWAY AND ELEVENTH STREET,
NEW YORK.

THE American Bell Telephone COMPANY.

95 MILK ST., BOSTON, MASS.

This Company owns the Letters Patent granted to Alexander Graham Bell, March 7th, 1876, No. 174,465, and January 30, 1877, No. 186,787.

The Transmission of Speech by all known forms of ELECTRIC SPEAKING TELEPHONES infringes the right secured to this Company by the above patents, and renders each individual user of telephones, not furnished by it or its licensees, responsible for such unlawful use, and all the consequences thereof and liable to suit therefor.

Original, Simple, Natural, Suggestive, Comprehensive, Educational and helpful entirely apart from the memory phase of the subject. JOURNAL OF EDUCATION

Memory SHEDD'S NATURAL METHOD, PRACTICAL, SCIENTIFIC.

Entirely different from any other memory method. Thoroughly taught by correspondence.

ENDORSED BY LEADING EDUCATORS.
DESCRIPTIVE PAMPHLET FREE.
MEMORY SCHOOL, 4 W. 14th STREET, NEW YORK CITY.

"The Week, one of the ablest papers on the continent."—*Descriptive America.*

ENLARGED AND IMPROVED.

THE WEEK:

A Canadian Journal of Politics, Literature, Science and Arts.

PUBLISHED EVERY FRIDAY.

\$3.00 per Year.

\$1.00 for Four Months.

THE WEEK has entered on its SIXTH year of publication, greatly enlarged and improved in every respect, rendering it still more worthy the cordial support of every one interested in the maintenance of a first-class literary journal.

The independence in politics and criticism which has characterized THE WEEK ever since its first issue will be rigidly maintained; and unceasing efforts will be made to improve its literary character and increase its value and attractiveness as a journal for the cultured home. Many new and able writers are now, or have promised to become, contributors to its columns, and the constant aim of the Publisher will be to make THE WEEK fully equal to the best literary journals in Britain and the United States.

As heretofore, PROF. GOLDWIN SMITH will, from time to time, contribute articles. London, Paris, Washington and Montreal letters from accomplished correspondents will appear at regular intervals. Special Ottawa Letters will appear during the sessions of Parliament.

THE WEEK in its enlarged form will be the same size as "Harpers' Weekly," and the largest paper of its class on the continent.

SEND FOR FREE SAMPLE COPY.

C. BLACKETT ROBINSON, Publisher,
5 Jordan St., Toronto.

IMPROVING THE MEMORY PICK

and facilitating the acquirement of knowledge by lectures and correspondence. Classes forming. "MEMORY and its Doctors," from Simonides to "Loisette," mailed for 25 cents (New Edition).

DR. PICK, 24 Union Square, N. Y. City

DAFT ELECTRIC LIGHT CO.

Power Stations.

Electric Railways.

Stationary Motors

Car Motors 15 to

$\frac{1}{2}$ to 100 H.P.

250 H.P.

Executive Office, - - - 115 Broadway, New York.

Factory, Jersey City, N.J.

Please Mention "Science."

To Prevent Consumption.

The attention of physicians is called to the report of Drs. Prudden, Biggs, and Loomis, on p. 465, and an expression of their opinions is desired, by the editor of *Science*, 47 Lafayette Place, New York, on the following points:—

1. Is consumption a distinctly preventable disease?
2. Is consumption directly inherited?
3. Is consumption transmitted by the tubercle bacilli?
4. What measures, if any, should be taken against the use of tubercular meat and milk?
5. What measures, if any, should be taken to limit the freedom of persons affected with tuberculosis?

REMARKS.

C. & C. ELECTRIC MOTOR COMPANY.

Electric Motors
 FOR
Arc and Incandescent Circuits, Most Economical Motor on the Market.
Regulation Perfect.
Motors Designed for all Power Purposes.

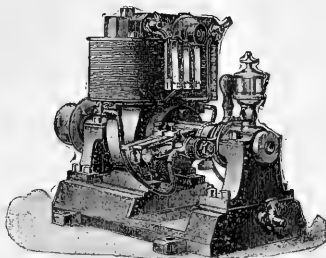

OFFICE and MANUFACTORY:
 402 and 404 Greenwich Street, New York City.
 New England Office, 19 Pearl St., Boston.
 Philadelphia Office, 301 Arch St.
 Western Office, 139-141 Adams Street, Chicago.
 Southern Office, 25 Carondelet Street, New Orleans.

16 PAGES. **THREE** PAGES.

Hundred Thousand new subscribers for *The Family Journal* and *Ladies Companion* wanted. It is the most interesting and instructive paper ever issued. Subscribers will receive during the coming twelve

MONTHS

novels written by American authors, complete in each three numbers. The story of popular works of fiction will be retold by a novel reader, the most interesting and unique feature ever introduced in any publication, giving the substance of popular and standard books by famous writers in a space easily read by the busiest people. We have engaged

FOR

this work a widely known and popular writer. Comments on foreign and original drawings, designs and ideas on any subject which we can use. Premium List the most complete in the world. We offer inducements to club raisers and agents approached by no other publishing house. The celebrated Gilbert Cut Waist Machines, which we send post paid to any one sending us two yearly subscribers at 60 cents each is alone worth 70 cents. 12¢ Sent to any address, post paid one year, 70 cents; six months, 35 cents; and a three months trial subscription for only 10 cents.

TEN CENTS.

TRY IT! TRY IT! TRY IT!
 and you will become a permanent reader. Address:
John L. Douglass, Publisher,
322 Broadway, N. Y.

A NEW MAGAZINE—THE SWISS CROSS
 Devoted to spreading a love of nature among the people. Edited by HARRIS H. BALLARD, President of the Agassiz Association, and succeeding *Nature* as the official magazine of that body. \$1.50 a year. Sample copy 10 cents. 50 cents for trial subscription for 3 months.
N. D. C. HODGES, PUBLISHER.
 Mention this magazine 47 Lafayette Place, New York.

Wants.

A YOUNG MAN can have lucrative engagement, not only a fixed salary, but according to his work accomplished in travelling for SCIENCE. A personal interview invited.

N. D. C. HODGES,
 47 Lafayette Place, New York.

MECHANICIAN.—An optician and maker of instruments of precision of experience would be glad of a position where his skill would be valued in connection with some higher educational institution. Address G. J., care of SCIENCE, 47 Lafayette Place, New York.

Scientific Apparatus.

J. GRUNOW,
 621 Sixth Avenue, New York.
 Established 1852.

MAKER OF

Microscope Stands, Oil Immersion Objectives and Abbe Condensers for Bacterial and Histological work, of Objectives, Camera Lucida and other accessory apparatus.

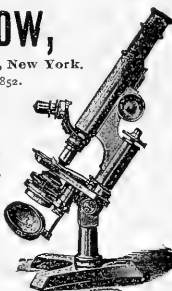

MORRIS EARLE & CO.
 SUCCESSORS TO
R. & J. BECK,

1016 Chestnut Street, Phila.

Microscopes and all Accessories and Apparatus. Photographic and Photo-Micrographic Apparatus and Outfits.

Spectacles, Eye Glasses, Opera and Marine Glasses, etc. Illustrated Price List mailed free to any address. Mention SCIENCE in corresponding with us.



IMPROVED OIL LIGHT MAGIC LANTERNS.

Also Lime and Electric Light Apparatus, and mechanical, plain, and fine colored views.

J. B. COLT & CO., Manufacturers,
 No. 16 BEEKMAN STREET, NEW YORK.



E. & H. T. ANTHONY & CO.

591 Broadway, N. Y.

Manufacturers and Importers of PHOTOGRAPHIC INSTRUMENTS, Apparatus and Supplies of every description. Sole proprietors of the Patent Detective, Fairy Novelty, and Bicycle Cameras, and the Celebrated Stanley Dry Plates.

Amateur outfits in great variety, from \$5.00 upward. Send for Catalogue or call and examine. 27 More than 40 years established in this line of business.

Readers of Science

Corresponding with or visiting Advertisers, will confer a great favor by mentioning this paper.

A few of the earlier bound volumes of "Science" (slightly "shop-worn") for sale at \$1.25 per volume. Mailed post-paid within the United States on receipt of price.

N. D. C. HODGES, 47 Lafayette Place, New York.

ELECTRICAL TESTING BUREAU,

Johns Hopkins University, Baltimore, Md.
 Resistance Coils and Boxes Compared.
 Am meters and Volt meters calibrated.
 Condensers standardized.
 Primary and Secondary Batteries Tested.
 Efficiency of Dynamos and Motors Determined.
 Insulation of Cables and Wires Tested.
 Etc., Etc.
 Circulars describing Methods Used, Prices, Etc., sent on Application.
 Address as above.

A TEMPORARY BINDER

for Science is now ready, and will be mailed postpaid on receipt of price.

Half Morocco - 75 cents.



This binder is strong, durable and elegant, has gilt side-title, and allows the opening of the pages perfectly flat. Any number can be taken out or replaced without disturbing the others, and the papers are not mutilated for subsequent permanent binding. Filed in this binder, *Science* is always convenient for reference.

N. D. C. HODGES,
 47 Lafayette Place, New York.

Sprague Electric Railway and Motor Company.

Lightest Weight Consistent with
Highest Efficiency.

SIMPLE IN CONSTRUCTION.

Not Liable to get out of Order.

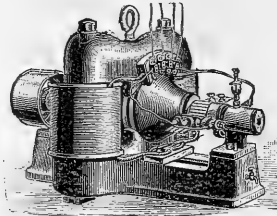

Bearings Self Oiling,
NON-SPARKING IN OPERATION.
Commutator Wear Reduced
to a Minimum.

16 and 18 BROAD STREET, NEW YORK.

The Mutual Life Insurance Company OF NEW YORK.

RICHARD A. McCURDY, PRESIDENT.

ASSETS - - - \$126,082,153 56

The Largest and best Life Insurance Company in the World.

The New Business of the Mutual Life Insurance Company in 1888

Exceeded \$103,000,000.

Its Business shows the Greatest Comparative Gain made by
any Company during the past year including

A gain in assets of.....	\$ 7,275,301 68
A gain in income of.....	3,096,010 06
A gain in new premiums of.....	2,333,406 00
A gain in surplus of.....	1,645,622 11
A gain in new business of.....	33,756,792 85
A gain of risks in force.....	54,496,251 85

The Mutual Life Insurance Company

Has Paid to Policyholders of this Organization \$272,481,839 82.



**KIMBAL'S
STRAIGHT CUT
CIGARETTES.**
Unsurpassed in quality.
Used by people of refined taste.
Highest award at Brussels, 1888.
The finest smoking mixtures are of
our manufacture.
Fifteen First Prize Medals.
WM. S. KIMBALL & CO.,
Rochester, N.Y.

ESTERBROOK'S STEEL PENS.

OF SUPERIOR AND STANDARD QUALITY.
Leading Nos.: 048, 14, 130, 135, 239, 333
For Sale by all Stationers.
THE ESTERBROOK STEEL PEN CO.,
Works: Camden, N. J. 26 John St., New York.



GOOD NEWS TO LADIES.

Greatest inducements ever offered. Now's your time to get up orders for our celebrated Teas and Coffees, and secure a beautiful Gold Band or Moss Rose China Tea Set, Dinner Set, Gold Band Moss Rose Toilet Set, Watch, Brass Lamp, or Webster's Dictionary. For full particulars address
THE GREAT AMERICAN TEA CO.,
P. O. Box 239. 81 and 83 Vesey St., New York.

PARIS EXPOSITION.

The Cheque Bank issues Cheques, either singly or put up in books, for the special use of VISITORS to the PARIS EXPOSITION, who can cash the same at upwards of seventy Banking Houses, situated in different parts of Paris, without charge.
Visitors of small matter can be addressed to them, Care of the Societe Generale, 4 Place de l'Opera, opposite the Grand Hotel, where English is spoken.
Every Cheque that is issued by the Cheque Bank is EQUAL TO CASH, as Bank Notes are, for the Bank's Capital, Guarantee Fund and Customers' Balances are invested in British Government Securities, or held in Cash in the Bank of England, and can be cashed in every town in Europe without charge.

For Handbook containing list of 2,500 Banking Houses who cash the cheques, free of charge, apply to
CHEQUE BANK, Limited,
Capital, £100,000. Guarantee Fund, £27,000.
Trustees, The Right Honorable John Bright, M.P., The Right Honorable Earl Beauchamp.
NO. 2 WALL STREET, NEW YORK.

Visitors to Europe and Paris Exposition should carry a book containing Cheque Bank Cheques, which are absolutely safe and cheaper than Letters of Credit, and much more convenient; are payable on presentation without charge at 2,500 Banking Houses and 250 of the principal Hotels in Europe.

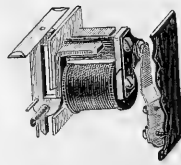

A
★
DROP
IN THE
PRICE
OF
★

GRAVITY

DROP

ANNUNCIATORS.

DON'T FORGET THE
DUST-PROOF BELLS.

HAZAZER & STANLEY,

32 Frankfort Street, N. Y.

SOMETHING NEW
THE PATENT
ADJUSTABLE PRUSH.

LIQUID GLUE
ALWAYS READY FOR USE
MANUFACTURED BY
RUSSIA CEMENT CO.
GLOUCESTER, MASS.

**THE STRONGEST
GLUE**
IN THE WORLD.
2 GOLD MEDALS
awarded at the
EXPOSITION
UNIVERSELLE
RUSSIA CEMENT CO.
GLOUCESTER, MASS.

Used by thousands of first-class mechanics and by such manufacturers as Pullman Palace Car Co., Mason & Hamlin Organ and Piano Co., &c., &c.

Repairs Everything.
It success has brought a lot of imitations copying us in every way possible. Remember that THE ONLY GENUINE LePage's Liquid Glue is manufactured solely by the
RUSSIA CEMENT CO.
GLOUCESTER, MASS.
Send 10c. and dealers' card who doesn't keep it in stock, for sample.

Patent Pocket Can. No waste

FOOD ADULTERATION

And its Detection. With photomicrographic plates and a bibliographical appendix. By J. P. Battershall. 328 pages, 8vo, cloth. Price, \$3.50. Circulars and Catalogues on application. E. & F. N. SPON, 12 Cortlandt St., New York.

SCIENCE

[Entered at the Post-Office of New York, N. Y., as Second-Class Matter.]

A WEEKLY NEWSPAPER OF ALL THE ARTS AND SCIENCES.

SEVENTH YEAR.
VOL. XIII. No. 333.

NEW YORK, JUNE 21, 1889.

SINGLE COPIES, TEN CENTS.
\$3.50 PER YEAR, IN ADVANCE.

THE NEW TWO-THOUSAND-TON CRUISERS.

THE new 2,000-ton cruisers authorized by an act of Congress approved in September, 1888, are improvements on the Yorktown and Concord class of vessels, being somewhat larger, and intended to make higher speed. They are twin-screw protected cruisers, having, in addition to coal protection to the machinery, a curved steel deck covering the magazines and steering-gear, besides the

These vessels, in their batteries, show how the modern idea of a ship's armament has changed, even in the short time that has elapsed since the United States began the rehabilitation of the navy. Guns of heavy calibers and few in number have gradually given place to those lighter in weight but greater in number, and capable of firing in a given time a much greater weight of projectiles. The main batteries of these vessels, which are the first to carry rapid-fire guns in the primary battery, will be made up of two

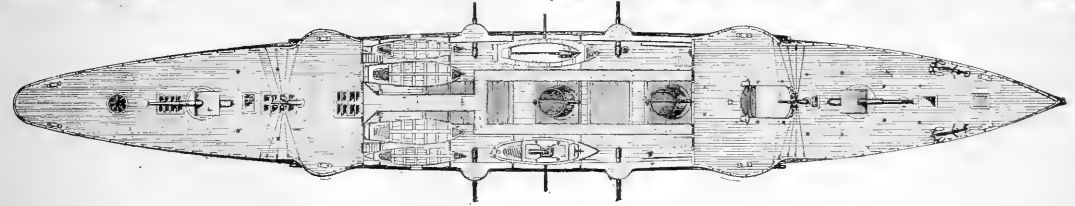
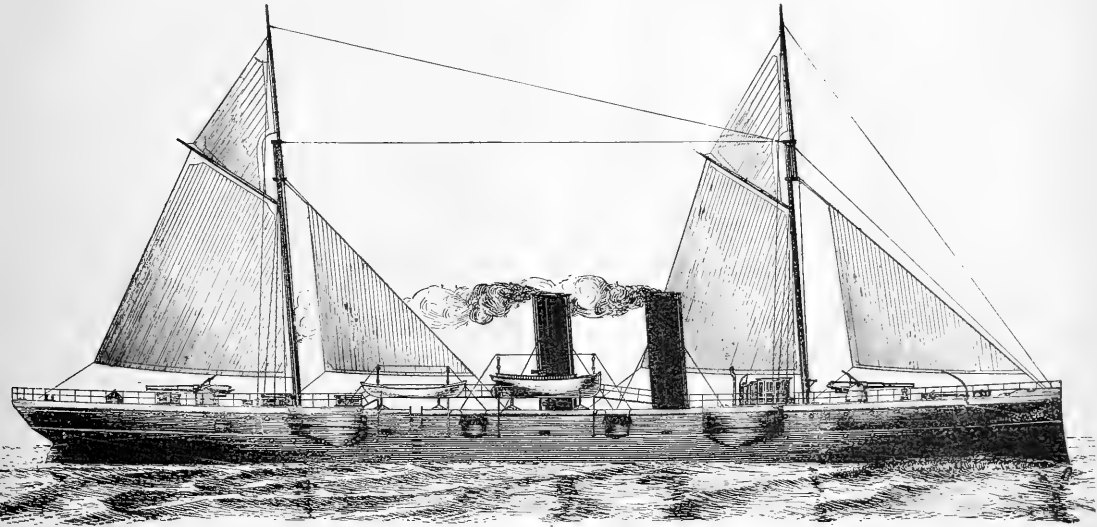

NEW 2000-TON CRUISERS.

engines and boilers, and also a coffer-dam protection extending throughout the entire machinery space. The interior arrangements of quarters are thought to be better than those aboard any of the other vessels, and present many innovations that will without doubt meet the hearty approval of those detailed to occupy them. The ventilation and lighting of all below-deck quarters, storerooms, passages, and so forth, are of the latest approved designs, and will conduce greatly to the health, comfort, and contentment of officers and crew.

six-inch and eight four-inch rapid-fire guns; the secondary batteries being two six-pounders, two three-pounders, two revolving cannon, and one Gatling gun. The motive power for the twin screws is furnished by two triple-expansion engines of 5,400 horse-power. The boilers are of steel, five in number, of the return fire tubular type, designed for a pressure of 160 pounds. Three of these boilers are double-ended; and the others, to be used as auxiliaries, are single-ended. The engines and boilers are in separate water-tight compartments. There will be independent air and circulating

pumps, and auxiliary condensers, and pumps for the auxiliary machinery. The torpedo outfit for auto-mobile torpedoes, probably of the Howell type, will consist of six launching-tubes, — one forward, another aft, and two on each broadside, — and in addition there will be the usual outfit of boat torpedoes. The rig is that of a two-masted schooner of small sail area, steam being the motive power on which the main deplacement will be placed. The cost of these cruisers will be \$700,000 each. The bids for them will be opened in August next.

ELECTRICAL POWER TRANSMISSION AT VIRGINIA CITY, NEV.

"MORE power, economical power," has now for several years been the imperative demand of the owners of mining properties on

At the stamp-mill of the Nevada Mill and Mining Company, water-power was obtained at the level of the mill from a reservoir on the side of the mountain. The mill contains 60 stamps, with their complement of pans, settlers, agitators, rock-breakers, etc. The water-power readily available was entirely inadequate for the operation of the mill.

The problem was submitted to the Brush Electric Company through its agents, the California Electric Light Company of San Francisco. A solution was speedily offered, and the plans were accepted by the owners of the Nevada Mill and Chollar Mine. The shaft of the latter is close to the stamp-mill. It was proposed to collect the waste water from the surface wheel at the mill, convey it in pipes to the shaft of the Chollar Mine, and thence down the shaft until a sufficient head should be obtained to produce the power required. The scheme was novel, and presented many diffi-

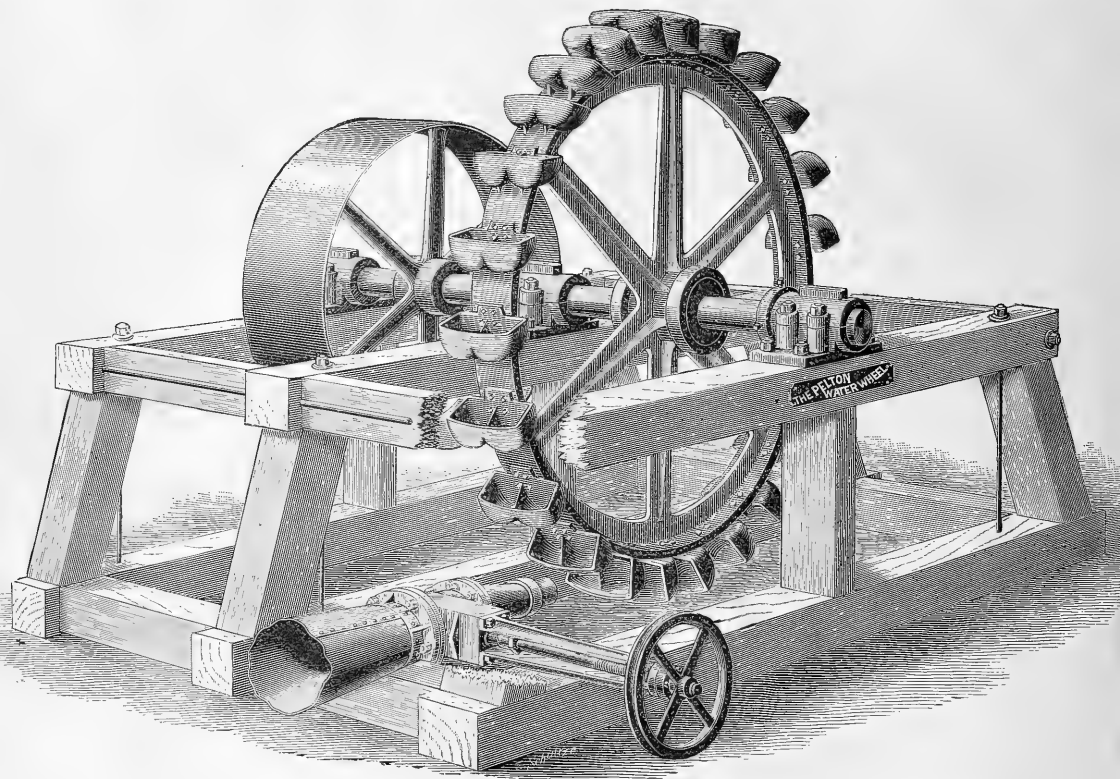

THE PELTON WATER-WHEEL USED UNDER 1680 FEET HEAD IN THE CHOLLAR MINE.

the celebrated Comstock Lode at Virginia City. The problem has been to work the enormous quantities of low-grade ore at a profit. Large sums have been expended in carrying water from streams in the neighboring Sierra Nevada Mountains for a distance of some thirty miles, to be utilized at the mines and mills on the Comstock. But this supply of water is limited and variable, and by no means meets the demand. Operations have frequently been suspended on this account, causing great loss to the mine-owners, and hardship to the laborers dependent upon the active working of the ores.

The best engineering talent of the country has been called to work on this vital problem of power-supply, and new arrangements have been made for increasing the amount of water; but vast powers now within reasonable range are still running to waste, which the use of electricity alone can conserve.

culties. However, experts pronounced the plans feasible, and work was begun last winter.

At the 1,650-foot level of the Chollar Mine a subterranean chamber was excavated out of solid porphyry for the reception of the dynamo electric generators and water-wheels. This chamber is 50 feet in length by 25 feet in width, and 12 feet in height, clear of all timbers. From the tank containing the waste surface water, two wrought-iron pipes are led to the subterranean chamber, one 10 and one 8 inches in diameter. At the bottom of the shaft a Y unites these two pipes into a single one 14 inches in diameter, out of which six 6-inch pipes run to the nozzles of the water-wheels provided to drive the large Brush dynamo electric generator.

The underground electrical station is of the most interesting character, and is shown in our illustrations. The large Brush pri-

mary generators, of which there are six, are adapted to the conditions by a few mechanical changes from the standard pattern. They are mounted on a heavy cast-iron base, and are provided with an extended shaft and outer bearing. On the armature shaft, and between two bearings, the Pelton wheel is mounted and enclosed in a water-tight cover. The cut of the generator is made from a photograph taken at the Brush Electric Company's works

excellent forms of water-wheels, the Pelton was selected as best adapted to work under the special circumstances. This wheel is the outgrowth of the old hurdy-gurdy form, and, as will be seen from the illustration, its buckets are provided with a very ingenious wedge-shaped partition, by which the stream of water is divided, and sweeps out through the curved sides in such a way as to produce a re-actionary effect in addition to the impact. By the pe-

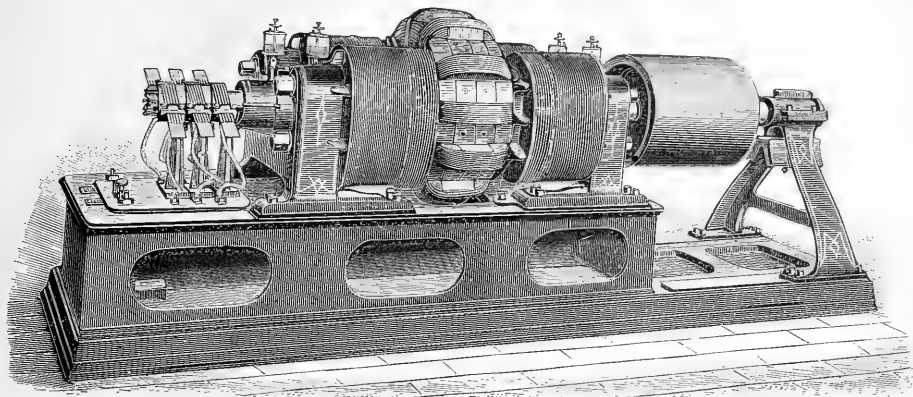

BRUSH DYNAMO, CHOLLAR MINE.

at Cleveland, before shipment, and shows a pulley on the armature shaft, arranged for testing-runs at the factory. The water-wheel is attached to the armature shaft at the place occupied by this pulley, and a coupling is provided for detaching this entire end of the shaft carrying the wheel from the other end carrying the armature.

These Brush generators are each of 130-horse-power capacity,

and the peculiar construction of the buckets, all the water is also thrown down and out of the way of the wheel. The six Pelton wheels are each 40 inches in diameter, are made of phosphor-bronze, and weigh 220 pounds. They drive the generators at the rate of 900 revolutions per minute. The compact arrangement of combined dynamo generator and water-wheel makes it almost impossible for the visitor to the underground chamber to realize the enormous

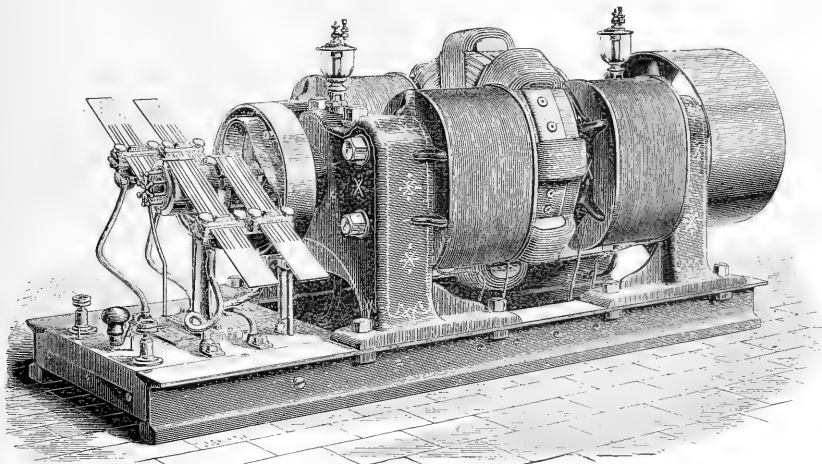

BRUSH ELECTRIC MOTOR, EIGHTY HORSE-POWER, NEVADA MILL.

and are compound wound for constant current. The electrical curve from these machines is almost ideally perfect, and they require no regulator whatever. The current remains of constant strength under all conditions of load.

The head of water at the underground chamber is 1,680 feet. It has never before been attempted to run a water-wheel under such enormous pressure. This was indeed one of the most serious problems involved in this remarkable installation. From the various

amount of power here at work. The machines are placed in parallel rows of three, and the swift-revolving armatures are all that can be seen in motion as evidence of the 800 horse-power generated. The chamber is brilliantly lighted by 36 Swan incandescent lamps, operated in multiple series from one of the Brush generators, and there are several of the same lamps in the incline. Each generator circuit is provided with a dead-beat ammeter of the Brush pattern; and a Brush voltmeter is also at hand, which is

capable of measuring up to 3,000 volts. The generator circuits are led to a switch-board in the same dynamo-room, where any generator can be thrown on to any one of the outgoing motor circuits.

Leaving this subterranean power station, and ascending the

The electric-motor room is shown in one of the large illustrations. The six motors are of the regular Brush constant-current type, each of 80-horse-power capacity, and are arranged in a single row parallel with the main driven shaft, to which they are all belted in the ordinary manner. The surface water-wheel is also

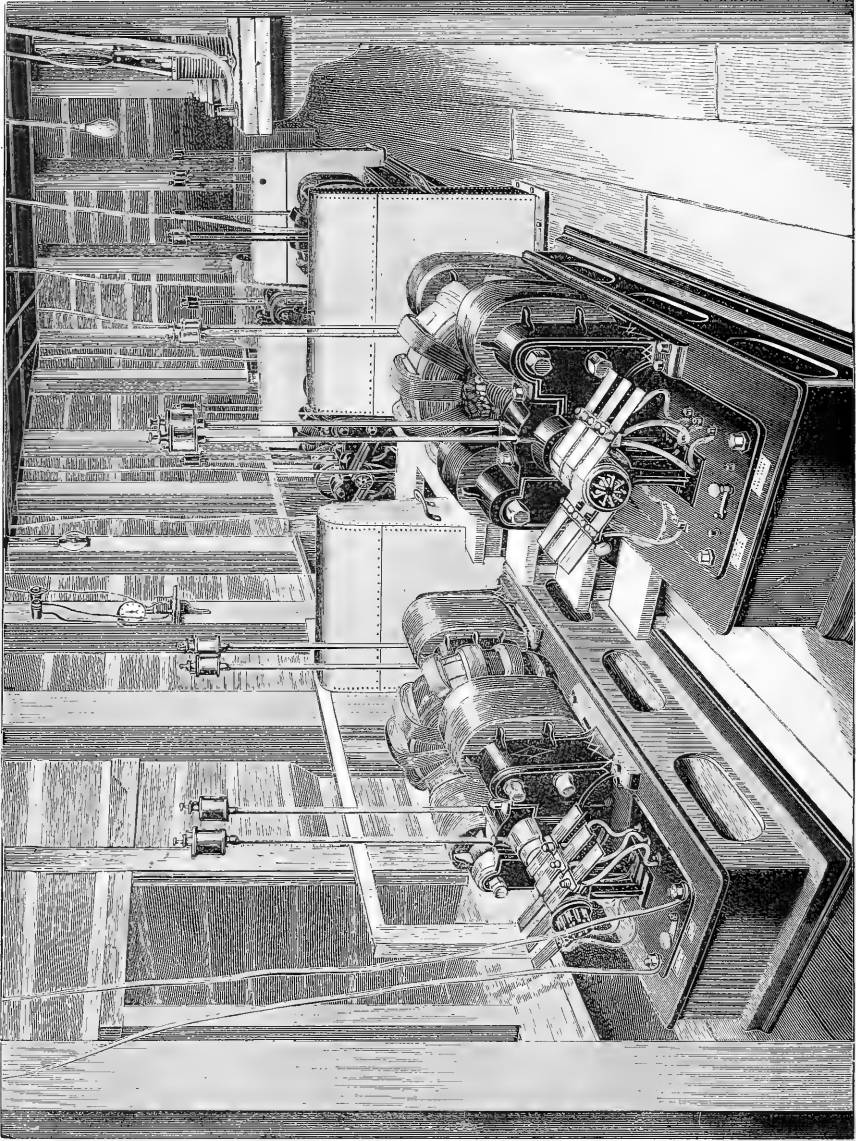

UNDERGROUND BRUSH POWER STATION AT THE 1660-FOOT LEVEL OF THE CHOLLAR MINE.

Chollar shaft, are the circuits of copper wire, one to each generator. At one point these circuit wires pass through a shower-bath of spray, but the insulation is so perfect that no leakage has yet developed. The wires issue from the mine shaft, and are carried above ground to the electric-motor room at the Nevada Mill. The total length of each circuit is a little more than a mile.

connected to this same shaft. It will be noted that there is here a very novel and interesting feature. This surface wheel uses the water in the first instance, and furnishes part of the power to drive the main shaft. The waste water, after this primary use, is carried down the Chollar shaft to the underground chamber, where it drives the dynamos which generate the electric current and ener-

gize the electric motors above ground, which in turn furnish additional power to the main shaft.

Each electric motor has its own independent circuit fed from one of the generators. The well-known Brush centrifugal governor, with which each motor is fitted, regulates the speed sensi-

none was encountered. The motors have not given a moment's trouble or annoyance of any kind from the start.

Some idea of the economic value of this electric power plant to the mine-owners may be got from a statement of the saving effected by it. The surface wheel alone requires 312 miner's inches of

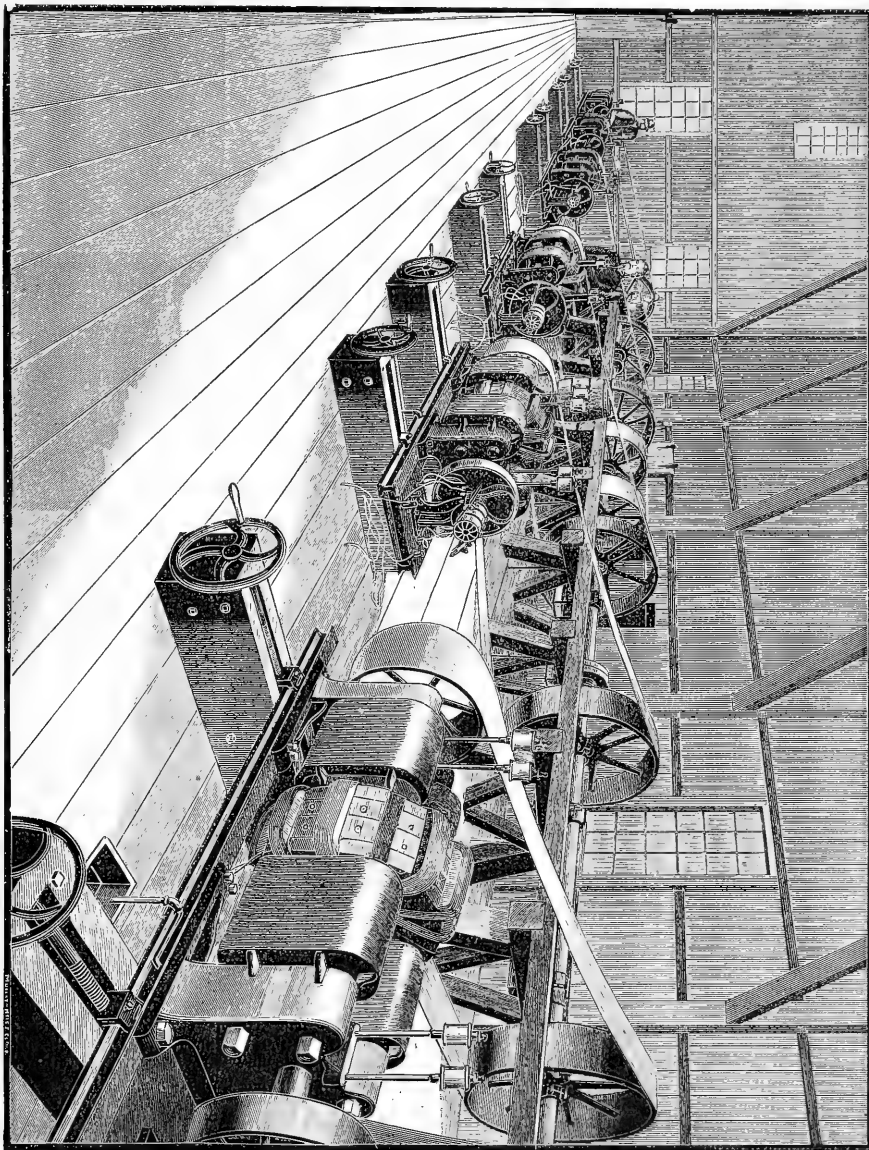

BRUSH MOTOR-ROOM AT NEVADA MILL.

tively, and all or any number of the motors work perfectly in a battery together or with the water-wheel. In the motor-room there is also an ammeter for each electric motor, to show at all times the current flowing in each circuit. The motors run at a speed of 850 revolutions per minute. Some difficulty was anticipated in operating the motors together on one shaft in the manner described, but

water to develop power sufficient to drive 40 of the 60 stamps with which the mill is equipped. Moreover, this amount of water is seldom available. Two of the electric motors, working in addition to the surface wheel, will perform the same service with but 72 miner's inches of water, thus effecting a saving of about 77 per cent.

The net commercial efficiency of the plant, taking into account all elements of loss, including that in the conducting wires, is about 70 per cent: in other words, 70 per cent of the power applied to the shafts of the generators in the underground chamber is delivered for work at the main line shaft in the mill.

The waste water from the 1,650-foot level of the Chollar Mine is piped into the Suto Tunnel. It is now proposed to use this water a third time at a lower level for other work, by means of a similar application of electrical machinery.

It was expected at the outset that many difficulties would be met in an installation of such novel and original character, which was also by far the largest ever attempted. The projectors, the Brush Electric Company and their agents, the California Electric Light Company, who assumed charge of the details of the erection, were very greatly pleased to find that their forethought had eliminated the troubles anticipated and predicted in almost all respects. Two purely technical difficulties were encountered when the plant was started experimentally, which caused some delay and anxiety. They were, first, the lack of any governing appliance for the water-wheels; and, second, the damage to the primary generators caused by the extreme heat and dampness in the underground station.

The Brush Electric Company, in its original plans and specifications, stipulated that the water-wheel should be governed within reasonable limits; but this requirement was not met, and the first generator and motor, started up experimentally, showed the necessity of this provision. The Brush Company was surprised to receive by telegraph the first intimation that the makers of the water-wheels had wholly neglected such an important matter, but was fortunately able to close the breach at once. A water-wheel governor, invented and sketched out by Mr. W. B. Devereux, the prominent mining engineer, of Aspen, Col., had been placed in the hands of the company some time previously, and working drawings of it had been made at Cleveland. These were at once sent to California, the governors were quickly made, and this source of trouble was overcome. Mr. F. E. Smith, the electrical engineer in charge of the installation, made several modifications of the governor, after watching its performance, which proved of much value, and it has worked perfectly in practical service.

The second difficulty was met with equal promptness, and likewise entirely overcome. The temperature of the subterranean power chamber is about 72° F. The atmosphere is almost saturated with moisture, — 78 per cent. Any piece of metal taken into it begins immediately to "sweat." The generators, when placed in this chamber, were soon covered and saturated with moisture, and began to show leaks, while the motors above ground were absolutely free from any trouble.

The Brush Company was at once notified of this unanticipated source of difficulty, and Mr. Brush speedily devised a method of insulation which would certainly and completely resist the moisture of the sublimated atmosphere. Since its application the generators have worked admirably, and the entire plant is now at work regularly, performing its expected duty, and economizing the power available, as stated above.

The achievement of the Brush Electric Company, in connection with this plant on the Comstock, is a very notable one, and of the greatest interest to mining engineers. The plant is the largest electrical power plant in the world. The company is making a specialty of powerful generators and motors for power transmission and distribution, and is taking large orders for them, not only in this country, but also for foreign shipments. The latest contract announced is one with the Calumet and Hecla Mining Company for five of the large Brush generators of 130 horse-power, and five of the 80 horse-power Brush motors. A power station will in this case be built above ground for the generators, and the motors will be used for driving pumps underground. The plant goes to the copper-mine at Calumet, Mich.

A MODEL SCHOOL OF ARCHITECTURE.

THE department of architecture of Columbia College has closed its work for the year with its annual exhibition of drawings. This department was organized eight years ago largely through the liberality of Mr. F. A. Schermerhorn, who contributed the neces-

sary funds to place it on a firm basis. It has grown with unusual rapidity, and is now one of the strongest parts of the School of Mines of Columbia College. During the past year, sixty-five students were registered in the department, an increase of twenty-five over the preceding year. The money furnished by Mr. Schermerhorn has enabled the trustees to supply a liberal collection of apparatus, models, books, photographs, and drawings; and the whole forms a collection of working material not equalled by another institution of the same kind in the country. Columbia is fortunate, also, in possessing in Professor William R. Ware, who has charge of this course, a teacher who combines sound technical knowledge with a warm sense of architectural form, and it is to him that the success of this school of architecture is chiefly due.

With a large body of students it is, of course, possible to produce large quantities of work, and this was the first noticeable feature in the recent exhibition. Four or five rooms were completely filled with the work of the students. Specimens were shown in all departments of architectural drawing. There were studies in historical ornament, many of them highly spirited sketches; problems, with details and perspectives; original designs; carefully prepared elevations; studies in perspective, in shades, and shadows; pencil drawings from the cast; memory drawings, — sketches from descriptions of photographs, and highly interesting as showing the attention that must have been given to the study of styles in order to produce such results; free-hand sketches of actual buildings and from photographs; applications of design and water colors. Nor was the quality of the work less noticeable than the quantity. In a collection of the work of an entire year, some drawings would be necessarily included that are more or less imperfect; but there were few of these, and they all evinced an extraordinary degree of application on the part of the students, and untiring energy on the part of the teachers and instructors.

Many of the pen-and-ink drawings were exquisitely done, and compared very favorably with the work of more experienced draughtsmen. The work of the students in this department does not cease with the conclusion of the college year. On the contrary, they are encouraged to enter architects' offices, and to make frequent sketches during the summer. One hundred drawings are required to be handed in at the beginning of the college year as evidences of summer work, though each day passed in an architect's office is accepted as the equivalent for a drawing. The hand and mind of the student are thus kept in constant practice, and there is no doubt but that much of the superior work in this school arises from the fact that the work is constant the year round, and is not interrupted by three months of idleness. One of the most interesting sections of the exhibition was that devoted to summer work. The exhibit was large, and included specimens of all kinds of drawings, both from actual buildings and from photographs. The quality of the subjects was an interesting commentary on the manner in which the tastes of these young men had been trained.

The problems of execution included a staircase, with perspective and detail drawings, elevation and details of a classical window, and several other subjects. All these were class-work, and were marked with the criticisms of the professor. Another interesting series were designs for a wrought-iron gate, and some studies for a Roman villa, by the first-year students. Space does not permit, nor is it necessary, to enumerate all the drawings shown. The exhibition was one to have been seen to be appreciated. The work was characterized not only by marked ability on the part of the students, but also testified to the great care and thought displayed by the teachers. The drawings showed an enthusiasm for the work which is not always to be found among undergraduates.

A word as to methods. The course in architecture extends over three of the four years' course in the School of Mines. The first college year is devoted by all the students to general studies; but in the second year the class is divided into sections, each pursuing a technical study. In the course in architecture, drawing is an important feature throughout the three years. In the first year the elements of architecture, with the forms and proportions of the five orders, are taught, together with the study of Greek and Roman architectural history. In the second year technical studies in the mechanics of solids are introduced, and a survey made of the ma-

terials employed in construction, their application and uses. In the fourth year, studies in the properties of materials are continued, and contracts, specifications, superintendence, and the details connected with the practical work of the architect, are considered. Throughout the whole course there are lectures and exercises in the history of architecture, as well as in the history of painting and sculpture, the aim being to make the students familiar with designs and styles which they might never even see in the daily routine of an architect's office.

The future of the department of architecture in Columbia College promises to be unusually brilliant. The trustees of the college have recently established a two-years' fellowship in architecture, which is the most valuable prize now open to architectural students in America. The conditions under which this will be awarded have not been decided as yet; but it will doubtless be a travelling fellowship, open to all the graduates of the department, thus enabling the recipient to pass two years in travel abroad. The income amounts to \$1,300 for the two years. New York will soon possess, in the Museum of Architectural Casts now being prepared for the Metropolitan Museum of Art, the finest collection of architectural models in the world. No part of this collection is yet in place, though a portion of it has been received at the museum, and the promises of the museum authorities indicate a collection of extraordinary value and interest. With this collection within easy reach, Columbia College will stand easily in the front rank of architectural schools in this country, and will compare favorably with the best in Europe. Each year witnesses some new improvement to the department, both in the way of teaching and in the apparatus. The schools of architecture in this country are limited in number, and it will require hard work on the part of the others to keep abreast with Columbia.

BARR FERREE.

NANSEN'S EXPEDITION ACROSS GREENLAND.

DR. FRIDTJOF NANSEN, whose daring expedition across the inland ice of Greenland excites so much well-merited admiration, gives the following description of his dangerous trip:—

"In the beginning of May, 1888, myself and the companions whom I had selected, Lieut. Dietrichson, Capt. Sverdrup, Mr. Christiansen, and the Lapps Samuel Balto and Ole Ravno, were ready to leave Christiania. After having reached Scotland, we sailed on the Danish steamer 'Thyra' for Iceland, whence the Norwegian sealer 'Jason' took us across Danmark Strait to the east coast of Greenland. The 'Jason' is a wooden steamer with full rigging. She is built for navigation in the ice-covered polar seas. Her bow is strengthened in order to withstand the heavy pressure of the ice setting along the east coast of Greenland. I hoped to find the ice sufficiently loose to permit us to reach the mainland by means of boats in the beginning of June. On June 11 we sighted the coast north of Angmagalik, where Capt. Holm's expedition wintered in 1884-85. We approached the land to within forty miles, but here our progress was stopped by the ice. As it seemed to fill the sea as far as the coast, I did not feel justified in an attempt to force a landing. For this reason we staid on the 'Jason,' which went sealing in Danmark Strait. After the sealing was finished,—about the middle of July,—we approached the coast of Greenland for a second time. At this season the belt of ice was not by any means as extensive as it had been in June. On July 17 we approached Angmagalik to within twelve miles, but we were again arrested by a heavy pack. As I supposed that we should be unable to approach any nearer the coast, I resolved to leave the steamer, and to attempt a landing. We left the 'Jason' with two boats, which were about twenty feet in length. Besides the boats, we carried a tent, two sleeping-bags made of deer-skin, and five long and narrow sledges for carrying provisions, ammunition, instruments, etc.

"In the beginning we made fair progress, as the ice was sufficiently loose to permit our boats to pass between the floes. Eventually we had to cut off a projecting point, but no serious obstacles were met with. At a few places we had to drag the boats over a floe, but our progress warranted the hope that we would reach the mainland on the following day. The farther we progressed, however, the closer the ice was packed, and the oftener the boats had to

be dragged over the ice. On one such occasion one of our boats was stove. She was unloaded as quickly as possible, and the necessary repairs were made. Thus four hours were lost. When we were ready to start, we found the ice so closely packed that we had to drag the boats continually. Travelling was made still more difficult when heavy showers of rain set in. We were thoroughly tired out, and it was necessary to encamp on the ice in order to regain strength to await the loosening of the pack. While we were encamped, the current carried the ice rapidly southward, and the distance to the coast was rapidly increasing. When it cleared up again, we discovered that we were about fifteen miles south of Sermilik Fiord. We endeavored to reach the coast; but travelling was extremely difficult, as the ice consisted of small and closely packed floes. Besides this, the current continued to carry us southward, and it seemed that the distance which separated us from the coast was continually increasing. Thus the day was spent. The weather was fair, but the current thwarted all our endeavors. At one time we were close to the shore; then the current carried us far out into the sea, and we felt the heavy swell of the ocean. One night, when sleeping in our tent, we felt a heavy swell, and the small floe on which we had pitched our tent was subjected to heavy pressure. On the next morning we saw that the floe was cracked near our camp, and that we were close to the edge of the pack near the open sea. The boats were made ready, and preparations were made to leave the ice. At night we had approached the edge of the pack still more closely. The sea washed over our floe, the size of which was rapidly decreasing. We knew what was before us. In order to be ready to take up the struggle with full strength, I ordered everybody to turn in. Sverdrup was ordered to watch, and to call all hands when it should be necessary to leave the floe. Sverdrup, however, did not call us, and when we arose on the next morning we heard the breakers at a long distance. During the night our floe had been so close to the sea that one of our boats was threatened by the waves; but all of a sudden it was drawn towards the land, and entered the pack-ice.

"After a few days the current carried us so close to the land, that we were able to reach the coast. On July 29 we went ashore near Anoritok in 61° 30' north latitude. During our twelve-days' stay on the ice, we were carried southward sixty-four miles. On the whole, the weather had been fair. Now we were on shore, but far southward from the point where I had hoped to reach Greenland, and where I intended to begin my journey inland. Therefore we had to go northward along the coast, as I was unwilling to change my plans.

"We started on the journey along the coast in the best of spirits. Whenever the ice was too close to the shore, we had to cut our way by means of axes, and we succeeded in making slow progress. On July 30 we passed the glacier Puisortok, which is so much feared by the East Greenlanders. On a point at the north side of the glacier we fell in with a party of natives who had visited the west coast on a trading excursion. This party, who were travelling in two women's boats, had met another party travelling in two boats, who were going southward on a visit to the west coast. We pitched our tent alongside their camp, paid them a visit, and were kindly received. On the next day we travelled in company with the first party northward, and reached the island of Ruds. The Greenlanders let us take the lead, in order to make use of the clear water made by our boats. In the afternoon rain set in. The Eskimo pitched their tents, while we continued our journey. Everywhere the ice lay close to the shore, and huge icebergs were pushed into the sea by the glaciers. At Tingmiarmiut we heard the dogs of the Greenlanders howling; but we had no time to spare, and continued our journey. On Griffenfeldt's Island we were overtaken by a northerly gale. At Akornarmiut we fell in with a new party of natives. They, however, were extremely timid, and as soon as they saw us they took to their heels, leaving behind their tents and one dog. We succeeded, however, in making friends with them by giving them a number of trinkets as presents, and on parting we were sincere friends. Numerous kayaks accompanied us when we continued our journey.

"Finally, on Aug. 12, we reached Umivik, whence, under the existing circumstances, I intended to start on my trip across the

inland ice. At this place the ice reaches the sea. Only a few *munataks* (summits of mountains) emerge from the ice, while there are no extensive stretches of land. A few days were spent in necessary preparations. Our boats were hauled on shore, turned upside down, and in one of them our spare ammunition was stored, in case we should be compelled to retrace our steps and winter on the east coast.

"On Aug. 15 we started inland. Our baggage was packed on five sledges, of which Sverdrup and myself dragged the heaviest one, while the others dragged one each. Every one had to drag a load of two hundred pounds, — a task which was made very difficult by the comparatively steep ascent of the ice, which was crossed by numerous deep fissures. During the first and second days we made fair progress, particularly as we slept during the day-time, and travelled at night on harder and better ice. On the third day we were overtaken by a terrible rain-storm, which detained us for three days. Then we proceeded in regular marches without meeting with any serious obstacles. The ground rose continually. The snow was hard but uneven. Thus we had proceeded for nine days in the direction of Christianshaab, the colony on the west coast which we tried to reach. Then, all of a sudden, a strong and continuous snow-storm set in. The road began to be bad, and we made slow progress. I saw, that, under these circumstances, it would take a long time to reach Christianshaab. It was near the end of August, and I expected that it would be extremely difficult to travel on the inland ice as late as September. On Aug. 27 I resolved to change my course, and to attempt to reach Godhaab. Thus we shortened the distance to be traversed; and the snow-storm, which for several days had blown right into our teeth, was more favorable to us, and helped us to drag our sledges. On the other hand, I knew that the descent from the inland ice to Godhaab would be much more difficult than at Christianshaab; but we resolved to make a boat, in case the land near Godhaab should prove too difficult.

"We were in about 67° 50' north latitude, and about forty miles distant from Godhaab Fiord, when we changed our course. Our sledges were provided with sails, for which purpose we used pieces of cloth. For three days we travelled on in this way; then the wind calmed down. Travelling became very difficult, and we had to use snow-shoes in order to prevent sinking into the snow. The surface was level and without fissures, but the ground was rising continually. It was not until the beginning of September, when we had reached a height of nine thousand or ten thousand feet, that we had reached the top of the plateau. We were on an enormous plain, level as a floor, and like a vast frozen sea. The snow was loose and fine. Small needles of ice were falling continually, and the temperature was so low that the mercury became solid. Unfortunately, I had no alcohol thermometer to show the lowest temperature, which must have been between 40° and 50° below zero. One night the minimum next to my pillow was — 31° F. We did not suffer, however, with the cold, except during a snow-storm.

"At last, on Sept. 19, a favorable easterly wind began to blow. We tied the sledges together, set sail, and made rapid progress westward. We were descending at the same time. In the afternoon we discovered the first mountain of the west coast. At night I suddenly discovered through the falling snow a dark spot, which we approached without fear of any danger. When we were at only a few steps distance, I discovered that the dark spot was a fissure. We succeeded in stopping the sledges at a few feet distance, but thereafter we proceeded more cautiously.

"The ice grew more impassable the more closely we approached the coast. Besides this, we had to change our course, as we had entered the great glacier emptying into Godhaab Fiord. On Sept. 24, at a small lake south of Kangersunek, we finally reached the land. Here we left part of our sledges and provisions, and went along the river Kukasik toward Ameragola, where we arrived on Sept. 26.

"Thus the inland ice was crossed; but we had to reach an inhabited place as soon as possible, as our provisions began to be exhausted. Besides this, our throats and mouths were swollen and sore by the long-continued use of pemmican. It was impossible to reach Godhaab by land, and we turned to building a small boat.

The felt floor of our tent was used as a cover of a frail frame which was built of willows and of a few poles. On Sept. 29, Sverdrup and myself started for Godhaab, while the others went to fetch the rest of our baggage from the edge of the inland ice. With great difficulty we succeeded in reaching New Herrnhut, a missionary station, on Oct. 3. After a visit to the missionary, we proceeded to Godhaab, which lies a short distance off. We were received very kindly. Two kayaks, with the necessary implements, were despatched at once to Ameragola to fetch the rest of our party. Unfortunately they were delayed by stormy weather, and we did not meet at Godhaab until Oct. 12. An attempt to return to Norway on the steamer 'Fox' from Ivigtut failed; but I must confess that I do not regret the necessity of having wintered in Greenland, as I had thus an opportunity to make a thorough acquaintance with the Greenlanders."

Thus Dr. Nansen concludes his preliminary report, which is soon to be followed by a scientific report. On April 16 the ship 'Hvidbjørnen' arrived at Godhaab, and on April 25 Dr. Nansen and his party left this place. After a brief stay at Sukkertoppen, which is situated a little more to the northward, and an unsuccessful attempt to cross the ice-pack of Davis Strait, the ship returned home. On May 19 the land of Norway was sighted, the next day Cape Skagen was reached, and on May 21 the steamer arrived at Copenhagen.

SIXTEENTH ANNUAL REPORT OF THE BOARD OF HEALTH OF NEW HAVEN.

In this report the efficient health-officer, Dr. S. W. Williston, presents in concise form the influences which have conspired to bring about a comparatively high death-rate in the city, — higher than in any year since 1881, though distinctly less than the average in the preceding years. This increase has been chiefly due to zymotic diseases, one-fourth of all the deaths being due to preventable causes. The mortality from diphtheria and membranous croup was nearly twice that of 1887; that from measles and diarrhoeal diseases was also high. From small-pox there were two deaths during the year. The history of these cases is both interesting and instructive, and emphasizes the necessity for a correct diagnosis in this disease. The first case was that of an engineer who contracted the disease in New York City. He had been vaccinated early in life, and thus escaped with varioloid, not more than thirty or forty pustules appearing on his body. His wife, attending him, was in due time taken with the same form of the disease. Both cases were treated for measles, both had measles previously, and both had been vaccinated in childhood. The family living on the floor below, consisting of Mr. D., his wife, and child, had never been vaccinated, save Mr. D. The wife was first to contract the disease, having nursed the second patient. She died of confluent small-pox. The daughter, six years of age, contracted the disease from her mother, but so soon that vaccination after the recognition of the disease did not suffice to prevent its occurrence, of which she died. A middle-aged lady, a relative, called in to nurse Mrs. D., was vaccinated for the first time six days after exposure. The vaccination formed a typical pustule, but did not prevent the occurrence of the disease in a mild form. The disease was confined to the one house; and all those thrown in contact with the cases, who had been properly vaccinated, escaped. The two who had never been vaccinated died. One who was first effectively vaccinated six days after exposure, had it in a mild form. The two who had not been vaccinated since childhood had a light varioloid. In commenting on this case, Dr. Williston says, "And yet, I am sorry to say, in the light of such evidence, that has been so often repeated, there are physicians in New Haven to-day who do not believe in vaccination!"

The history of typhoid-fever in New Haven during the year is of special interest with reference to the localities in which this disease appeared. In recent years in Brooklyn this fever has seemed to be especially virulent in the better portions of the city, and to be practically absent from those sections in which the sanitary conditions are inferior; so much so, that it has become a popular impression in that city that typhoid-fever is a disease of the rich and well-to-do, and not of the poor. This was not true of New Haven

during 1888. Of the total cases, 210 in number, one-third occurred in the seventh ward, whose population is one-tenth of the entire city. Dr. Williston states that this ward is known to be in poor sanitary condition. The greatest factor in the mortality of the city was pulmonary consumption, which caused 217 deaths; next comes pneumonia, with 142. From infantile diarrhoea there were 137 deaths; from old age, 50; cancer, 40; and typhoid-fever, 38.

NOTES AND NEWS.

THE meeting of the Society of Microscopists will be held at Buffalo, N.Y., beginning on Aug. 21. Professor T. J. Burrill, Champaign, Ill., is the secretary.

— The peasant proprietors in Russia, says a writer in the *Nineteenth Century*, can neither pay the money owing to the government for their land, nor even the state and communal taxes, and are flogged by hundreds for non-payment. In one district of Novgorod, fifteen hundred peasants were thus condemned in 1887. Five hundred and fifty had already been flogged, when the inspector interceded for the remainder. Widespread famine is found over a great part of the country. Usurers, the bane of peasant proprietors in all countries, are in possession of the situation. The Koulaks and Jew "Mir-eaters" supply money on mortgage, then foreclose, and, when the land is in their possession, get the work done for nothing as interest. These bondage laborers, as they are called, are in fact slaves, and are nearly starved, while the small pieces of land are often re-united into considerable estates, and their new owners consider they have only rights, and no duties. Meantime, as forced labor is at an end, and free labor is of the worst possible kind, the old land-owners can get nothing done. They have tried to employ machines, bought by borrowing from the banks, and are now unable to repay the money. The upper class has been ruined, with no advantage to the peasant.

— The thirty-eighth meeting of the American Association for the Advancement of Science will be held at Toronto, Ont., beginning on Tuesday, Aug. 27, 1889, at noon, by a meeting of the council at the Queen's Hotel, where will be the hotel headquarters of the association. On Wednesday, Aug. 28, the first general session of the meeting will begin at ten o'clock in the forenoon in the Convocation Hall, University Buildings. After the adjournment of the general session, the several sections will organize. In the afternoon the vice-presidents will give their addresses before their respective sections; and in the evening there will be a general session, when the retiring president, Major J. W. Powell, will deliver his address. The sessions will continue until the Tuesday evening following, and on Wednesday morning, Sept. 4, a meeting of the council will be held. Saturday, Aug. 31, will be given to excursions. The meeting will close with excursions extending to Sept. 7. The general sessions and the meetings of the sections will be held in the University Buildings, where also will be the offices of the local committee and of the permanent secretary during the meeting. Board and lodging for members and their families may be had at moderate rates in several hotels and boarding-houses within easy reach of the place of meeting; and, as the local committee will provide a lunch, members will not be obliged to return to their lodgings during the heat of the day. In the evening, when not otherwise engaged, it is expected that the members of the association and of the local committee will meet socially in the reception-rooms at the hotel. A special circular in relation to railroads, hotels, excursions, and other matters, will be issued by the local committee, and members who are about changing their address for the summer should notify the local secretary at once. It can now be stated, however, that arrangements have been made by Mr. Dudley and the special committee on transportation by which members and their families will be, in general, able to obtain return tickets for one-third the regular rate, provided members are particular in complying with the conditions of the agreements with the passenger agents of the several railroad associations, which will be given in detail in the local committee circular. Without obtaining such a certificate as will be described in the local committee circular, to be countersigned at the meeting, the reduced rate for return ticket cannot be secured. For all matters pertain-

ing to membership, papers, and business of the association, address the permanent secretary at Salem, Mass., up to Aug. 22. From Aug. 22 until Sept. 9, his address will be A.A.A.S., Toronto, Ont. Members remitting back assessments before Aug. 22 will receive their receipts and volumes of "Proceedings" at once from Salem; those paying by mail after that date (and not present at Toronto) must not expect their receipts and volumes until after the meeting. The Cleveland volume of "Proceedings" will be sent during this month to all members who have paid the assessment for that meeting. The assessment receipt for the Toronto meeting must be shown at the time of registering, in order to obtain the association badge, which entitles the member to the privileges of the meeting. If members pay the assessment for the Toronto meeting in advance, and remember to take the assessment receipt to Toronto, they will save standing in the crowd before the secretary's desk, and can register at once on arrival after the opening of the register on Aug. 27. Under the rule which took effect in 1884, members have the privilege of registering members of their families (not including men over twenty-one years of age) by paying the sum of three dollars for each individual to be registered. These associate members will receive badges entitling them to all the privileges extended to members generally by the local committee. Special information relating to any of the sections will be furnished by their officers. Arrangements have been made for a discussion in Section B on the "Relative Merits of the Dynamometric and Magnetic Methods of obtaining Absolute Measurements of Electric Currents." Professor Thomas Gray of the Rose Polytechnic Institute will open the discussion with a paper on the subject, and he will exhibit one or more of Sir William Thomson's most recent forms of electric balance. Arrangements have been made by the local committee for the proper care and exhibition of instruments and specimens, for the details of which, and for all other local matters, members should address the local secretary. In anticipation of the circular to be issued by the local committee, it is only necessary here to give the names of Charles Carpmael, Esq., president of the committee; and of Professor James Loudon, local secretary, Toronto, Ont. Members of the association arriving in Toronto before the meeting should call for information at the temporary office of the local secretary, near the Union Railway Station.

— The Entomological Club of the American Association will meet at 9 A.M., Aug. 28, in the room of Section F, University Buildings, where members of the club will register, and obtain the club badge. Members of the club intending to contribute papers will send titles to the president, Mr. James Fletcher, Government Experimental Farms, Ottawa, Can. The Botanical Club will hold a meeting, as usual, on Tuesday, Aug. 27, in the room of Section F, University Buildings. Communications should be sent to the president, Professor T. J. Burrill, Champaign, Ill., or to the secretary, Douglas H. Campbell, 91 Alfred Street, Detroit, Mich. The Society for the Promotion of Agricultural Science will hold its tenth annual meeting in Toronto, beginning on Monday evening, Aug. 26, in the room assigned to Section I in the University Buildings, and continuing on Tuesday. For further information address Professor W. R. Lazenby, secretary, Ohio State University, Columbus, O. The American Geological Society will hold its meeting in Toronto on Aug. 28 and 29. Professor James Hall, Albany, N.Y., is the president; and Professor J. J. Stevenson, University of City of New York, secretary.

— Mr. Samuel Butler concludes a whimsical article in the *May* number of the *Universal Review* — an article which he hopes may give his readers absolutely no food whatever for reflection — with words which, though themselves whimsical, are not without their salt of truth, and might perhaps frustrate the very hope which he expresses. "I have sometimes thought," he says, "that, after all, the main use of a classical education consists in the check it gives to originality, and the way in which it prevents an inconvenient number of people from using their own eyes. That we will not be at the trouble of looking at things for ourselves if we can get any one to tell us what we ought to see, goes without saying; and it is the business of schools and universities to assist us in this respect. The theory of evolution teaches that any power not worked at

pretty high pressure will deteriorate; originality and freedom from affectation are all very well in their way, but we can easily have too much of them; and it is better that none should be either original or free from cant but those who insist on being so, no matter what hinderances obstruct, nor what incentives are offered them to see things through the regulation medium. To insist on seeing things for one's self is to be an *ἰδιώτης*, or, in plain English, an idiot; nor do I see any safer check against general vigor and clearness of thought, with consequent terseness of expression, than that provided by the curricula of our universities and schools of public instruction. If a young man, in spite of every effort to fit him with blinkers, will insist on getting rid of them, he must do so at his own risk. He will not be long in finding out his mistake." There is a fine flavor of "Hudibras" in this view of the case, which Mr. Sully might use as an example of heredity.

—The university delegates have decided, says the *Educational Times*, to arrange a second meeting of university extension and other students in Oxford in August next. The objects of the meeting are to stimulate and direct systematic home study by means of short courses of lectures, to supplement university extension teaching by a brief period of residence and study in Oxford, and to afford opportunities for conference between teachers and others interested in education on the best means of developing university extension and other educational work. The meeting will be divided into two parts. The arrangements for the first part, which will last ten days, will be similar to those which were successful last year. The second part of the meeting will consist of a supplementary period of three weeks' quiet study. The first part of the meeting will begin with an inaugural address by Professor Stuart, M.P., on Tuesday, July 30, and will end on Friday evening, Aug. 9. During the ten days there will be delivered on each morning, at 10.15, and at noon, short courses of lectures on history, literature, science, art, and political economy, and a number of evening lectures of a more general character. Among those who have already promised their assistance are Professor Max Müller, Professor S. R. Gardiner, Sir Robert Ball, Mrs. Fawcett, Rev. W. Hudson Shaw, Messrs. Arthur Sidgwick, R. G. Moulton, R. W. Macan, H. J. Mackinder, E. B. Poulton, D. S. M'Coll, F. Madan, etc. The second part of the meeting will begin on Saturday morning, Aug. 10, and end on Friday evening, Aug. 30. It is proposed that this period should be devoted to quiet study. Lectures will be delivered each morning at 9.45 and 11.45, and a class will be held after each lecture. The courses will be longer than those of Part I., and will deal in greater detail with the subjects then introduced.

—The strife between "Classics" and "Moderns" has assumed great proportions in Holland. Professor Naher of the University of Amsterdam has made the proposal that Greek should be removed from the curriculum of the gymnasia, and should only be compulsory for those who wish to study philology. It is to be noted that Herr Naher is a professor of classical philology. At present, every Dutch student, to obtain a certificate of maturity, must show proficiency in German, French, and English, as well as in Greek and Latin.

—The Michigan Legislature has just appropriated for the Michigan Mining School, \$104,000 for the furnishing and maintenance of the school during the years 1889 and 1890.

—The annual report of the Ohio Meteorological Bureau for 1888 shows that at the close of 1887, forty-seven observers were reporting to the bureau. Five of the number were officers of the United States Signal Service, and six were reporters of rainfall only. The number of stations now reporting is fifty-two. The work of the observers is entirely voluntary and without pay. It has been performed continuously and faithfully, as the tabulated results show. The distribution of weather telegrams, through the kindly interest of Gen. A. W. Greely, chief signal-officer at Washington, D.C., has been continued through the year. Of the thirty-six stations to which the telegrams were sent at the beginning of the year, seventeen were discontinued during the year, mainly because of the failure of display-men to properly display the predictions and report to the bureau. Seventeen new stations were added during the

year. These telegrams are furnished at government expense, the only conditions imposed being that the places receiving them should provide proper flags and arrange for their prompt display on receipt of the telegrams, and to report monthly on printed forms supplied for the purpose. The board of directors acknowledge their indebtedness to Gen. Greely for the encouragement and material aid which he has given in the prosecution of the work of the bureau. Without it, it would have been impossible to perform the work which has been done the past year with the funds set apart by the State for the purpose. In addition to the reports of current weather observations, a number of interesting and important special reports have been published in the monthly numbers through the year.

—Dr. George Owen Rees, F.R.S., died at Mayfield, Watford, Herts, on May 27. Dr. Rees took his degree of M.D. at Glasgow in 1837, and became a fellow of the Royal Society in 1843.

—We learn from *Nature* that the foundation-stone of the Framjee Dinshaw Petit Laboratory of Scientific Research, in Bombay, was laid on April 8 by Lord Reay. Mr. Petit, the son of the donor, explained that it had appeared to his father desirable, in the interests of medical education, that a laboratory for scientific research in biological and physical sciences should be established. He had long cherished the wish to have the properties of Indian drugs investigated, and made known to medical students. The laboratory will be connected with the Grant Medical College.

—Every one who takes the slightest interest in natural history will be sorry to learn that the kangaroo is in danger of being extinguished. Its skin is so valuable, says *Nature*, that large numbers of young kangaroos are killed; and high authorities are of opinion, that, unless the process is stopped, Australians will soon have seen the last specimen of this interesting animal. Mr. R. G. Salomon, one of the largest tanners in the United States, whither kangaroo-skin is chiefly sent, urges that a fine should be imposed for the killing of any kangaroo whose skin weighs less than ten-twelfths of a pound; and from a note on the subject in the *Zoologist*, by Mr. A. F. Robin of Adelaide, we are glad to see that a serious attempt is being made to secure the enforcement of this restriction throughout Australia and Tasmania, and the proclamation of a close season between Jan. 1 and May 1. We must hope that the Australian legislatures will understand the necessity of taking speedy action in this matter. It would be scandalous if, in deference to the wishes of a few greedy traders, they were to allow Australia to lose the most famous and most interesting of its characteristic fauna.

—A report was issued on Oct. 16, 1888, from the province of Santa Catherina, Brazil, on the newly introduced ramie-plant. The reporter, who is director of a colony called Grao Para, says that 1,000,000 plants are growing there of the sort called *Urtica utilis*, which is best qualified to resist cold, and able to survive frosts in the ground, without being pulled up and stored. It is not being propagated by seeds, but by transplanting its very numerous suckers, and putting them into the ground horizontally, so that they grow from each knot. They grow best in sandy soil, as in stiff wet soil the roots rot, but they must be strictly protected from wind. They are planted in August and September, and cropped as soon as they are six feet high, and are dark brown at the base. The colony, says the *Textile Recorder*, has a Delantsheer machine moved by water-power, which cost £120 on the spot. At the Concours International de la Ramie, on the Quay d'Orsay, this machine was stated to cost £40. This machine gives satisfactory but not very good results. The colony got the first prize, a gold medal, at Antwerp, for its ramie-fabrics, and a manufacturer in the United States offered, without success, to supply machinery gratuitously to the colony in return for a monopoly of its produce of ramie. Commander Joaquim Caetano Pinto introduced the plant from Europe, and on Jan. 5, 1889, he signed a contract with the minister of agriculture by which he engages to import to the colony, at the public expense, two hundred more families of immigrants. The government also undertakes to help him by a donation of £3,000 for the first hundred families, and as soon as they have arrived, but not sooner, to begin making a road to the nearest railway-station on

the D. Thereza Christina line. It may be added that Brazil is peculiarly suitable for ramie, as here its uncontrollable tendency to spread would not give the considerable inconvenience which it does in older countries.

— The news comes from Madras that that portion of the world is ravaged both by famine and cholera. The province of Ganjam is where the epidemic has reached its greatest intensity. The official figures put the deaths at one thousand per week from cholera.

— During a discussion over the educational budget in the Belgium Senate recently, a member attracted attention to the constant increase in the number of students at the universities, — an increase which showed, in his opinion, that the examinations were too easy, and which threatened to overload the liberal professions.

— Since the end of the third week in May the water of the Seine has been distributed in two *arrondissements* of Paris. Usually this only happens during the hottest weather, towards the end of June or the early part of July. This year it will probably be necessary by that time to furnish the Seine water to a large part of Paris. The water is not considered especially healthful, and will attract the attention of visitors to the exposition by its yellow color.

— Sir John Bennett Lawes, the eminent agricultural scientist, of Rothamstead, has, it is stated, just completed arrangements for bequeathing to the cause of agricultural science the sum of £100,000, together with fifty acres of land and the laboratory and museum at Rothamstead. In the latter are stored more than 45,000 bottles of experimentally grown produce, of animal products and of soils. The income of the fund will be handed over to a committee of nine persons, including the owner of Rothamstead for the time being.

— Professor Dr. Foster, director of the University Ophthalmic Clinique at Breslau, has recently drawn the attention of parents and pedagogues to what he believes is often the cause of shortsightedness in the young; namely, that they are allowed to wear collars which are too tight for them. In three hundred cases that had come under his notice the patients were suffering from a chronic complaint brought on by a disturbance in the regular and normal flow of blood, caused by the wearing of collars which were not large enough.

— India, it would seem, is practically uneducated. The total number of scholars in schools and colleges of all sorts is only three and a quarter millions, or $1\frac{1}{4}$ per cent of the entire population. These are mainly confined to the cities and towns; and out of 250,000,000 in all India, less than 11,000,000 can read and write. A census of the illiterates in the various countries of the world, recently published in the *Statistische Monatsschrift*, places the three Slavic states of Roumania, Servia, and Russia at the head of the list, with about 80 per cent of the population unable to read and write. Of the Latin-speaking races, Spain heads the list with 63 per cent, followed by Italy with 48 per cent, France and Belgium having about 15 per cent. The illiterates in Hungary number 43 per cent, in Austria 39, and in Ireland 21. In England we find 13 per cent, Holland 10 per cent, United States (white population) 8 per cent, and Scotland 7 per cent, unable to read and write. When we come to the purely Teutonic states, we find a marked reduction in the percentage of illiterates. The highest is in Switzerland, 2.5; in the whole German Empire it is 1 per cent; in Sweden, Denmark, Bavaria, Baden, and Württemberg, there is practically no one who cannot read and write.

— The problem of separating the mica in the tin ores by a simple and effective process is claimed to have been solved by Professor Carpenter of Dakota. If this should be true, says *The Engineering and Mining Journal*, and the deposits in the Black Hills prove any thing like as extensive as they have been represented, it ought to aid the establishment of a vast tin-plate industry to compete with the foreign producers.

— The success of the petroleum borings in Galicia would lead us to expect, according to *The Engineering and Mining Journal*, that the Austro-Hungarian Empire will be totally independent of a foreign supply of oil. Formerly there was a tendency to speak

slightingly of Galician oil-deposits, owing to the fact that a large proportion of the wells were dug by hand. Of late years the American method of drilling has been introduced, and many Galicians have become accomplished drillers. In the Lodyna district, wells of a profitable character have been bored. Galician wells have not the copiousness of Russian; but a readier market exists for the oil, and the demand for Lodyna petroleum is such that it is sold at a high rate long in advance of appearing on the surface. The oil-belt of Lodyna is five miles long, and intersected by a railway, thereby enabling the oil to be sent to the refineries at a trifling expense. A few years ago all the refineries in Galicia did not produce 1,000,000 gallons of refined oil, but now their production exceeds 6,000,000 gallons. The Austrian Government takes great interest in the development of the petroleum industry, and has adopted a protective policy which has already succeeded in establishing the Galician oil-trade on a firm basis. In consequence of this and of such successes as the recent borings at Lodyna, where wells have been struck giving a profit of 500 or 600 per cent, the financial and commercial world in Austria has been deeply moved, and petroleum has caused much excitement.

— *Forest and Garden* states that important rose-shows in England this summer will be held as follows: July 2, Boston, Sutton; July 10 and 11, Brighton, Ealing; July 17, Bedford; July 26 and 27, Wilmslow.

— James K. Reeve, in *The Chautauquan* for July, makes some very practical suggestions regarding perfume flower-farming. He says, "The Hon. Norman J. Coleman, late commissioner of agriculture of the United States, in a recent personal letter to the writer of this paper, stated that in his opinion there is in this country, undoubtedly, a vast and undeveloped field suitable for the culture of perfume-yielding plants and flowers, notably on the borders of the Gulf of Mexico, and expressed the belief that the commercial floriculture of this region may yet rival the production of the Mediterranean coast, and become not only the great flower-garden of America, but of the world. A leading perfumer of New York tells me that experiments in perfume flower-culture have been made in most of our Southern States, and that domestic pomades have been frequently offered to dealers, but not of a quality sufficiently good to warrant their use. They attribute this to ignorance of the conditions necessary to the proper production of the pomades, and not to any lacking element in our floriculture. As a home industry in which the surplus labor of a household could be profitably employed, there is nothing which seems at once so practicable and pleasing as this. When flowers are introduced into our gardens as a commercial factor, the gardens will receive more of the time and attention of that portion of our households who most need the out-door life, the strength and color, the health and happiness, that may be found in them.

— The site for the zoölogical garden in Washington has been selected. It comprises about one hundred and fifty acres to the north-west of the city, about two miles from the White House, along the banks of Rock Creek, and is said to be in every way well adapted for its purpose. Before next winter the necessary arrangements will probably be so far advanced that the animals now housed in the grounds of the Smithsonian Institution can be removed to their new quarters.

— Professor Patrick of the Iowa Agricultural College, says *Garden and Forest*, undertook last winter to make a chemical study of apple-twigs to ascertain whether he could detect differences of composition between the young growth of such varieties as are hardy and those which are not hardy in that region. At the same time and for the same purpose a microscopic examination was made of apple-twigs by Dr. Halsted. It would be a great advantage if hardy and tender varieties could be distinguished from each other by a chemical analysis or an examination of their cell-structure. Professor Budd, indeed, has expressed the opinion that there was an apparent difference in the structure and composition of the trees which proved hardy in Iowa and those which were tender. The results of Professor Patrick's analysis "lend, perhaps, some slight encouragement" to this idea. Professor Halsted found "no parallelism between microscopic structural differences and ability to withstand the influences of a trying climate."

SCIENCE:

A WEEKLY NEWSPAPER OF ALL THE ARTS AND SCIENCES.

PUBLISHED BY

N. D. C. HODGES,

47 LAFAYETTE PLACE, NEW YORK.

SUBSCRIPTIONS.—United States and Canada.....\$3.50 a year.
Great Britain and Europe..... 4.50 a year.
Science Club-rates for the United States and Canada (in one remittance):

1	subscription 1 year	\$ 3.50
2	“ 1 year	6.00
3	“ 1 year	8.00
4	“ 1 year	10.00

Communications will be welcomed from any quarter. Rejected manuscripts will be returned to the authors only when the requisite amount of postage accompanies the manuscript. Whatever is intended for insertion must be authenticated by the name and address of the writer; not necessarily for publication, but as a guaranty of good faith. We do not hold ourselves responsible for any view or opinions expressed in the communications of our correspondents.

VOL. XIII.

NEW YORK, JUNE 21, 1889.

No. 333.

CONTENTS:

THE NEW TWO-THOUSAND-TON CRUISERS..... 471	EDITORIAL..... 482
ELECTRICAL POWER TRANSMISSION AT VIRGINIA CITY, NEV. 472	Teaching Girls Music. — Pulmonary Consumption. — Deaf-Mute In- struction in Cincinnati.
A MODEL SCHOOL OF ARCHITECTURE <i>Barr Ferree</i> 476	DANGER LURKING IN DECOMPOSING ANIMAL OR VEGETABLE FOOD... 483
NANSEN'S EXPEDITION ACROSS GREEN- LAND..... 477	BOOK-REVIEWS.
SIXTEENTH ANNUAL REPORT OF THE BOARD OF HEALTH OF NEW HAVEN..... 478	Fundamental Problems..... 484
NOTES AND NEWS..... 479	Hygiene of the Nursery..... 484
	Statics for Beginners..... 484
	AMONG THE PUBLISHERS..... 484
	LETTERS TO THE EDITOR.
	Cloud and Fog <i>H. A. Hasen</i> 487
	Osteological Notes <i>D. D. Stade</i> 488

PROFESSOR WÄTZOLDT, the director of the Elisabethschule (a girls' school in Germany), has addressed a most serious warning to parents and guardians on one of the evils of the present system of teaching girls. It is on the subject of what Wagner has contemptuously called *Hammermusik*. The professor begins by pointing out that the terms "musician" and "pianoforte-player" are not at all convertible. Then he refers to the illogical conduct of so many parents, who, for the sake of their children's health, ask them to be excused certain subjects of the school course, while they encourage them in the most excessive exertions at the pianoforte. Now, there is no subject which, if taught seriously, makes such a demand upon the store of nervous energy of the body as instrumental music. The brain, the eye, and the hands are all exercised at once; hence the frequent injury to health in the case of girls who have not a strong constitution. The professor has collected some statistics which show that more than half the pupils are taught the pianoforte, and that after their tenth year they spend twice as much time daily at it as at their other home lessons. Many girls complain of feeling tired, absent-minded, fidgety, of headaches and sleeplessness; and these complaints grow worse as they grow older. In all cases where the parents could be prevailed upon to diminish the hours of pianoforte practice, or stop it altogether, a marked improvement in general health was the invariable result. Herr

Wätzoldt, therefore, recommends (1) that pianoforte instruction, should not begin until the age of twelve; (2) that only girls of sound health, and who show some talent for music, should be made to play. We also agree with the final observations of the professor, who must be a true lover of genuine music. "It is an indubitable fact," he says, "that nine-tenths of the girls, after years of arduous practice, only attain to a certain automatic technique, which kills all true feeling for art, and renders a normal bodily development impossible. We know how difficult it is to fight against the fashions and vanities of the day; but, if it is only shouted from the house-tops that true art and culture have nothing whatever to do with mediocre *Klavierhammern*, there will be some, at least, in the maddening crowd that will pause and reflect; and these, by a lucky chance, sometimes become leaders who set a better fashion to the unreflecting masses."

PULMONARY CONSUMPTION IS MORE TO BE FEARED in every community than any other disease that affects mankind. Cholera, yellow-fever, and small-pox — diseases that paralyze with fright entire countries — are exceedingly limited in their results, in comparison with the slaughter of consumption. Last year Florida was panic-stricken from the havoc of yellow-fever; but during the same year consumption destroyed more than twice as many lives in the little State of New Hampshire, and not a tremor ran through the body corporate. The average annual death-rate in this country, from cholera, yellow-fever, small-pox, typhoid-fever, diphtheria, and scarlet-fever, all combined, does not reach the enormous total of deaths from consumption. It is time that some determined and systematic effort be made to lessen this disease which is now regarded by so many as preventable. Among the general sources of infection there is one, at least, that should be removed, or, if not wholly removed, greatly lessened by legal action, and that is the sale of tuberculous food-products. Such foods, chiefly in the form of tuberculous meat and milk, particularly the latter, are undoubtedly extensively sold to unsuspecting consumers; and that the results are not infrequently lamentable, no sanitarian doubts. The general government has taken no measures to restrict this abuse, nor have the individual States. To illustrate: the New Hampshire State Board of Health says that very recently complaint was made to the Board of Cattle Commissioners that some disease existed in a herd of thirty cows in a certain town of the State; and, under the assumption that the disease might be pleuro-pneumonia, the government, upon notification, sent a competent veterinary surgeon to inspect the herd. The inspector immediately diagnosed tuberculosis, had an infected cow killed, and the post-mortem examination revealed tubercles in nearly every organ of the body, including the udder. The inspector reported that about seventy-five per cent of the herd was already infected. All, or nearly all, the cows were being milked, and the product being sold daily to a milk-dealer for distribution among his customers. The dairyman, ignorant of the character of the disease, was bringing up a baby upon the milk of a single cow in which the disease had advanced nearly to its fatal termination. Under the laws of New Hampshire, neither the Board of Cattle Commissioners nor the State Board of Health has any authority to deal with tuberculosis in cattle in a way necessary to restrict its spread among other herds, or to prevent the dangers to which it subjects the human family.

THERE ARE CONNECTED with the public-school system of Cincinnati, classes for the instruction of deaf-mutes. Two of these classes receive their education through the well-known methods of signs or finger-movements; while at the Sixth District School on Elm Street, above Fifteenth Street, there is a separate school of

some thirty pupils, who are being taught to readily understand every thing said to them by watching the movements of the speaker's lips, and are themselves in turn taught to speak and read aloud through the oral method. This class of scholars was organized some three years ago, and resulted in the formation of a society for the improved instruction of deaf-mutes. About one year ago the society succeeded in having provision made whereby the classes should form part of the public-school system. There should be better provision made, however, for the development of this branch of the public-school system. More room is needed for the pupils; additional instructors are required; and, beyond any question of dispute, this work, so well begun by private subscription, should be fostered and cared for out of the school fund. There are now being made efforts to have schools located in different parts of the State, and at the next session of the Legislature there will be presented a bill in which the State will be expected to pay for the education of all deaf-mute citizens of the State by this oral method.

DANGER LURKING IN DECOMPOSING ANIMAL OR VEGETABLE FOOD.¹

MUSCARINE as a product of putrefaction has already been alluded to by me in my last report for the chemical department of the Agricultural College, and in foreign scientific journals, where the case has attracted some attention as furnishing facts previously unknown. My connection with the occurrences reported originated through the death of four persons from the consuming of fish-containing-food in a slightly putrid condition; and my analysis of the food was undertaken at the solicitation of the police department of the Hokkaidō Chō.

Two adults and two children living in Chitose died suddenly with symptoms of narcotic poisoning. Post-mortem examination, however, failed to satisfactorily account for death; but the appearance of the organs, together with the ante-mortem symptoms, were considered by the officiating physicians to resemble poisoning from the poisonous mushroom (*Agaricus muscarine*).

Specimens of the food eaten by the deceased were therefore sent me for chemical examination. The articles received were two; namely, a variety of edible mushroom, and a native food called "sushi," consisting of a mixture of fish and rice with a little *saké*, which is allowed to ferment and become vinegar before the mixture is eaten. The fish was *gnozi*, one of the most common and wholesome of Japanese river-fish. In the former of the two substances subjected to examination, no trace of alkaloid or other injurious substance could be detected. The "sushi," however, reached me in an advance stage of putrefaction. (This food is usually eaten in a condition decidedly "strong.") I was therefore compelled to recognize the uselessness of attempting the elimination or recognition of alkaloids by the usual methods of procedure, and to admit the extreme probability of the presence of some ptomaine as a product of decomposition. The methods pursued and the results obtained may possibly require a brief introduction, that the facts involved may be the better recognized. Only the briefest possible *résumé* of the facts necessary for a better consideration of the questions involved is here admissible. The relations between alkaloids and albuminoids are known to be most intimate. The latter, acted on by certain micro-organisms, undergo a decomposition known as putrefaction, and the life-function of certain of these organisms results in the conversion of albuminoids into alkaloids; this latter group of compounds consisting chiefly of poisonous substances, until recently supposed to be exclusively of vegetable origin. Though numerous instances of poisoning through the consumption of food undergoing the process of putrefaction are recorded, and as long ago as 1822 Garpert and Stick made known the existence of a specific poison in decomposed animal matter, it was not till 1877 that really definite knowledge was evolved from the facts accumulated. The Italian chemist Selmi then first isolated a basic compound, of alkaloid character and toxic properties, of unmistakable putrefactive origin, and named by the discoverer "*cadavres alkaloid*," or "ptomaine."

¹ Report by H. E. Stockbridge, Ph.D., of the Government Agricultural College, Sapporo, Japan.

In 1880 the Italian minister of justice appointed a commission of chemists and pharmacists to investigate the entire field thus opened, and formulate the facts gathered. The work thus begun has been continued by the investigators of different countries, until there are now known and isolated not less than twelve of these alkaloids of putrefaction, seven of which have been made known through the labors of Dr. Brieger of Berlin since 1883. It is chiefly to this investigator that we are indebted for the enunciation of reliable methods of elimination and recognition.

The method adopted by me in the investigation undertaken was in most respects identical with that recommended by Brieger, the modifications being only such as were suggested by the somewhat peculiar nature of the substance and the circumstances demanding the examination; the ptomaines thus far eliminated being for the most part insoluble in ether, while the latter removes large quantities of organic matter, the presence of which renders subsequent purification more difficult. I first subjected the mass to one hour's extraction with warm ether in an automatic extraction apparatus of my own device. The extract thus obtained was set aside for future examination; and the residue, slightly dried, and free from fats and other ether-extracted matter, was heated with water acidulated with hydrochloric acid for two hours, the temperature being kept below 100° C. The solution thus obtained was evaporated to a thick sirup over the water-bath, an acid re-action being carefully maintained, and the residue extracted several times with absolute alcohol, until the addition of alcohol failed to precipitate more nitrogenous matter. The fluid solution was then evaporated to dryness, the residue taken up in 90 per cent alcohol filtered and precipitated with platinic chloride. The precipitate thus formed was then treated with an excess of water; the alkaloid-platinum double salt, if present, going into solution, from which the insoluble platinum compound was separated by filtration. The solution was next subjected to a stream of hydrogen sulphide till all platinum was precipitated, the solution being then neutralized by sodium carbonate, and evaporated to dryness. This residue was repeatedly washed with absolute alcohol, and the solution obtained evaporated to dryness over the water-bath and then taken up in water. This solution should now contain the pure hydrochloride salt of any alkaloid extracted from the original substance by the acidulated water.

Allowed to slowly evaporate over sulphuric acid, fine laminar opaque crystals were formed, which were found to be soluble in alcohol and in water, but insoluble in ether. The aqueous solution gave with phospho-molybdic acid and with mercuric-potassium iodide amorphous precipitates. Mercuric chloride produced a white amorphous precipitate, crystallizing after some time. With gold chloride, a bronze-colored non-crystalline precipitate was obtained.

Platinum bichloride yielded a fine slightly crystalline precipitate of great insolubility. Excess of bromine-water produced a reddish-brown precipitate, soon disappearing.

The identity of the compound with muscarine, the poisonous constituent of the "toadstool," seems to be thus established, and is further confirmed by the evidence of the post-mortem on the victims of the consumption of the food from which the alkaloid was isolated. The official report of the examining physicians mentioned muscarine symptoms. No mushrooms were, however, found in the stomachs, though, because of the symptoms, some were furnished me for analysis. The further confirmation of elemental analysis has not yet been possible, since the total amount recovered was not more than sufficient for analysis; it was therefore deemed inexpedient to resort to the destruction of what might, under the circumstances, be required as evidence. A combustion analysis will, however, ultimately be made, and the results recorded. The ether extract made before the treatment with acidulated water, was subsequently found to contain an alkaloid yielding white crystals over sulphuric acid, and a crystalline precipitate with gold chloride. I have as yet, however, been unable to establish the identity of this compound, and therefore reserve further details, together with results of efforts to "cultivate" these products of decomposition at will, for some subsequent report.

Muscarine, so far as I am able to ascertain, has not heretofore been recorded among the ptomaines isolated and named, although

its existence as a product of putrefaction has been suspected; and Brieger speaks of the "*muscarin äuliche Wirkung*" of an alkaloid isolated by him, but is not satisfied of its identity, as this alkaloid is not included in the list of those discovered and recorded by him.

The case I have here reported is, moreover, doubtless the only one yet investigated wherein muscarine, heretofore known only as a vegetable alkaloid, has been found as a decomposition-product in a food the consumption of which has resulted in death, attended by the well-known symptoms of muscarine-poisoning. The facts observed and here recorded seem to present one more illustration of the intimacy existing between the composition and decomposition of animal and vegetable organisms, and furnish an additional proof of the interest and importance of this new field of investigation. Interest in the researches made in this new domain must be proportional to their importance, capable as they are of developing facts of so universal significance, and dealing with transformations occurring not only in the food we may eat, but in any animal body as well, and demanding new methods of lego-chemical investigation.

During the past year I have continued the investigation begun the previous season, and am now able to report the repeated isolation of muscarine as a product of the putrefaction of the food from the eating of which the four people at Chitose died, and, moreover, have been so fortunate as to discover two new and heretofore unknown ptomaines. One of these was obtained from the original ether extract; but, though their character has been carefully studied, I prefer to reserve opinion as to identification.

Discussion of the scientific interest and value of these facts is here out of place; but their practical value is, however, of widespread importance and applicability, both from sanitary and legal points of view. We are forced to recognize the danger of eating either animal or vegetable food after decomposition has begun, since this process may result in the development of deadly poisonous alkaloids resembling in physiological properties, strychnine, morphine, brucine, and other of the most powerful poisonous alkaloids hitherto known only as products of vegetable growth. Many diseases of a cholera-like character, perhaps even this most dreaded malady itself, may result from the consumption of food in which the process of putrefaction has begun. From a legal standpoint, chemists, physicians, and jurists are now compelled to recognize the possibility that many supposed cases of criminal poisoning are in reality the result of ptomaine-formation, either in food or in the decomposing body after death.

BOOK-REVIEWS.

Fundamental Problems. By DR. PAUL CARUS. Chicago, Open Court Publ. Co. 12°. \$1.

THE author of this work is the editor of the *Open Court*, a paper professing to teach a new religion, and most of the chapters of which the book consists have already appeared in the columns of that paper. The object of the book is to set forth the philosophy of Dr. Carus, which, we suppose, must be taken as the basis of that improved religion which the *Open Court* was founded to teach. One merit the work certainly has: it is, except in the ethical part, plainly written, and leaves no doubt as to what the author's philosophy is. It is a crude and crass materialism. Indeed, we have never seen a work in which the materialistic view was presented in so extreme a form as in this of Dr. Carus. Thus, in discussing the origin of feeling, he says, "We must expect the solution of this problem from biological investigations. . . . The conditions of feeling must exist in the inorganic matter of our world, and the appearance of the phenomena of sensation will be found to depend upon a special form in which the molecules of protoplasma combine and disintegrate" (pp. 10-11). And elsewhere he says that "it is not improbable that feeling will be demonstrated as a special kind of reflex action in organized substance" (p. 185). "The ego . . . is the result of the innumerable and complicated nerve organisms in our body" (p. 214). And then, as if these assertions were not sufficient, Dr. Carus declares "it is undeniable that immaterial realities cannot exist. The thing exists by its being material" (p.

86). He ridicules the idea of a First Cause, even when conceived as the Unknowable, and calls it a chimerical nonentity. God is variously spoken of as the All-existence and as the order of the world. The doctor's ethical theory is confused and inconsistent. He rejects utilitarianism, and at first adopts Kant's view that the moral law is purely formal, without any reference to ends; yet again he says that man is moral "by observing and conforming to the cosmical order of nature;" and both these views are supplemented by the theory that morality consists in living for the ideal, though what the ideal is we are nowhere informed. Such are Dr. Carus's views; and we are constrained to say that we do not think they will revolutionize either philosophy or religion.

Hygiene of the Nursery. By LOUIS STARR. 2d ed. Philadelphia, Blakiston. 12°. \$1.

WHEN the first edition of this manual appeared, we said, that, of the many books which have been published on this subject, this was by far the best. This, the second edition, is, by virtue of a thorough revision and numerous additions, superior to the first. It has our hearty commendation.

Statics for Beginners. By JOHN GREAVES. London and New York, Macmillan. 16°. 90 cents.

THIS work on "Statics for Beginners," by John Greaves, fellow and mathematical lecturer of Christ College, Cambridge, England, assumes no knowledge beyond "Euclid," Books 1-6, and elementary algebra, with a few propositions in trigonometry. Collections of easy examples are inserted after the more important propositions, while examples of greater difficulty are given at the ends of the chapters.

AMONG THE PUBLISHERS.

MESSRS. GINN & Co. announce as in preparation "Practical Latin Composition," by W. C. Collar, A.M., head master of the Roxbury Latin School, Boston, and author of "The Beginner's Latin Book" and "Collar's Eysenbach." This book embodies a method that has been followed by the author for many years with the most satisfactory results. A brief explanation of the method will show how rational it is, how well it accords with the principles of language-teaching now most approved, and how simple and effectual an aid it should prove to a real understanding of Latin. The book consists of three classes of exercises, all based on selections from the Latin authors usually read in schools. The first exercise of each group contains easy sentences to be turned into Latin orally,—sentences involving the use of words, idioms, and constructions of the Latin text assigned for study in preparation. The second exercise consists of a short passage of continuous English to be written out in Latin, based on the same Latin text as the preceding. The third exercise, which may be omitted at the teacher's option, contains questions in Latin, to be answered in Latin, on the subject-matter of the original, but not introducing either words or grammatical principles that are unfamiliar. Notes and occasional grammatical references accompany the exercises.

—"From Nineveh to the Lake; the Deluged Valley of the Conemaugh; Scenes Afoot," is announced by Alex. Y. Lee, architect and civil engineer, 96 4th Avenue, Pittsburgh, Penn. This is an extended bird's-eye view of the valley of the Conemaugh, Johnstown, and the lake, finely lithographed and drawn from personal sketches, and based upon surveys of the Pennsylvania Railroad.

—Roberts Brothers have just ready, in their series of Balzac's works, "Seraphita," which is the completing volume of Balzac's three philosophical novels, of which "The Magic Skin" and "Louis Lambert" have already been issued by this house. Many critics have so little understood the real meaning of "Louis Lambert" and "Seraphita," that they have wondered why the author gave them a place in the *Comédie Humaine*, which, nevertheless, without them, would be a temple without a pediment, as M. Taine very clearly saw and said. Mr. George F. Parsons takes advantage of Miss Wormeley's translation to state and prove and elucidate this truth in an introduction, and all serious readers who follow it throughout will never regret that they have thus prepared themselves to understand Balzac's work.

— Barnicott & Son, Taunton, England, have issued another edition of their useful "Country Gentleman's Reference Catalogue to the Best Works on Agriculture, Botany, Natural History, Sporting, Recreations, Domestic Management, and Kindred Subjects."

— Sir Morell Mackenzie, in the *Contemporary Review*, in writing of stimulants and the voice, says, "Tobacco, alcohol, and fiery condiments of all kinds are best avoided by those who have to speak much, or at least they should be used in strict moderation. I feel bound to warn speakers addicted to the 'herb nicotian' against cigarettes. Like tipping, the effect of cigarette-smoking is cumulative, and the slight but constant absorption of tobacco juice and smoke makes the practice far more noxious, in the long-run, than any other form of smoking. Our forefathers, who used regularly to end their evenings under the table, seem to have suffered little of the well-known effects of alcohol on the nerves; while the modern tippler, who is never intoxicated, is a being whose whole nervous system may be said to be in a state of chronic inflammation. In like manner cigarette-smokers (those, at least, who inhale the smoke, and do not merely puff it 'from the lips outward,' as Carlyle would say) are often in a state of chronic narcotic poisoning. The

old jest about the slowness of the poison may seem applicable here; but, though the process may be slow, there can be little doubt that it is sure. Even if it does not kill the body, it too often kills or greatly impairs the victim's working efficiency and usefulness in life. The local effects of cigarettes in the mouth must also be taken into account by those whose work lies in the direction of public speech. The white spots on the tongue and insides of the cheeks, known as 'smoker's patches,' are believed by some doctors with special experience to be more common in devotees of the cigarette than in other smokers. This unhealthy condition of the mouth may not only make speaking troublesome, or even painful, but it is now proved to be a predisposing cause of cancer. All fiery or pungent foods, condiments, or drinks tend to cause congestion of the throat; and, if this condition becomes chronic, it may lead to impairment, if not complete loss, of voice. The supposed miraculous virtues of the mysterious possets and draughts on which some orators pin their faith exists mainly in the imagination of those who use them: at best, they do nothing more than lubricate the joints of the vocal machine, so as to make it work more smoothly."

**Publications received at Editor's Office,
June 10-15.**

- BALZAC, H. de. *Seraphita*. Tr. by Katharine Prescott Wormeley. Boston, Roberts, 275 p. \$1.50.
 COCKSOTT, A., and Walters, P. B. *A Treatise on Geometrical Conics*. London and New York, Macmillan, 205 p. 12°. \$1.25.
 CRANE, T. F. *La Société française au Dix-Septième Siècle*. London and New York, Putnam, 342 p. 24°. \$1.50.
 HELPS, A. *Essays written in the Intervals of Business*. London and New York, Macmillan, 130 p. 16°. 60 cents.
 PAUL, H. *Principles of the History of Language*. Tr. by H. A. Strong. New York, Macmillan, 512 p. 8°. \$3.

- WALLACE, A. R. *Darwinism: an Exposition of the Theory of Natural Selection with Some of its Applications*. London and New York, Macmillan, 494 p. 12°. \$1.75.
 WRIGHT, G. F. *The Ice Age in North America and its Bearings upon the Antiquity of Man*. New York, Appleton, 622 p. 8°. \$5.

FOR SALE.

Three original drawings by Baron Cuvier. No. 1, in pencil, *The Anatomy of a Snail*. No. 2, in water-colors, *Kingfisher and Insects*. No. 3, in water-colors, *Insects*. The two last were drawn when Cuvier, a lad of sixteen, was at the University of Stuttgart. Price \$50. Apply to T. H. H., Office of "Science," 47 Lafayette Place, New York.

Schools.

CONNECTICUT, NEW HAVEN,
MRS. CADY'S SCHOOL FOR YOUNG LADIES.
 Prepares for Smith and Wellesley, and admits to Vassar by Certificate. Circulars. Early application necessary.

NEW JERSEY, PLAINFIELD.

THE CHESTNUTS.—Parents with daughters to educate, or orphan girls with companion, may find a comfortable home, with school instruction by applying to Miss E. E. Kenyon.

NO. 1. NOW READY.

THE NEW REVIEW.

Edited by Archibald Grove.

CONTENTS FOR JUNE 1889.

GENERAL BOULANGER:—

I. **His Case** (Written with his authority).
 By Alfred Naquet (Member of the French Senate).

II. **His Impeachment.** By Camille Pelletan (Member of the French Chamber).

After the Play. By Henry James.

The Homes of the People. By Earl Compton, M.P.

National Muscle. By Lord Charles Beresford.

The Religion of Self-Respect. By Mrs. Lynn-Linton.

The Unionist Policy for Ireland. By J. W. Russell, M.P.

A Month in Russia. By Lady Randolph Churchill.

Published monthly 15 cents. Yearly Subscription \$1.75.

LONGMANS, GREEN & CO.,

15 EAST SIXTEENTH ST.,

NEW YORK.

Old and Rare Books.

One Million Magazines. Back numbers, vols. and sets—old and new, Foreign and American.

CATALOGUE UPON APPLICATION.

A. S. CLARK,

34 Park Row, New York City.

BACK NUMBERS and complete sets of leading Magazines. Rates low. AM. MAG. EXCHANGE, Schoharie, N.Y.

Houghton, Mifflin & Co.'s New Books.

Emerson in Concord.

By EDWARD WALDO EMERSON. With a new Portrait. Crown 8vo, gilt top, \$1.75.

A charming book, portraying Mr. Emerson in private life, as "the citizen and villager and householder, the friend and neighbor."

George Washington.

In the Series of American Statesmen. By HENRY CABOT LODGE, author of "Alexander Hamilton" and "Daniel Webster" in this series. 2 volumes, 16mo, gilt top, \$2.50.

Thackeray's Works.

New Illustrated Library Edition.

VANITY FAIR and LOVEL THE WIDOWER. 2 volumes.

THE HISTORY OF PENDENNIS. 2 volumes.

MEMOIRS OF YELLOWPLUSH.

BURLESQUES, etc. 2 volumes.

The first volumes of a very desirable Illustrated Library Edition of Thackeray's Works, to be made more complete than any existing edition, in 22 volumes, with bibliographical and bibliographical introductory essays. Crown 8vo, gilt top, \$1.50 a volume.

The Beginnings of New England.

The Puritan Theocracy in its Relations to Civil and Religious Liberty. By JOHN FISKE. With maps. Crown 8vo, gilt top, \$2.00.

Mr. Fiske has here produced a book of equal interest and importance. His conscientious thoroughness of research, his marvellous candor, and the unsurpassed clearness of his style are conspicuous in this work.

Indoor Studies.

By JOHN BURROUGHS. 16mo, gilt top, \$1.25.

CONTENTS: Thoreau—Science and Literature—Science and the Poets—Matthew Arnold's Criticism—Arnold's View of Emerson and Carlyle—Gilbert White's Book—A Malformed Giant—and several briefer essays.

N. B.—The price of Mr. Burroughs's other books, heretofore \$1.50 each, is now \$1.25.

Riverside Library for Young People.

Sterling and interesting books of history, biography, travel, natural history, adventure, etc., written by authors specially qualified, for boys and girls forming private libraries.

1. **THE WAR OF INDEPENDENCE.** By JOHN FISKE.

2. **GEORGE WASHINGTON;** An Historical Biography. By HORACE E. SCUDDER.

3. **BIRDS THROUGH AN OPERA-GLASS.** By FLORENCE A. MERRIAM.

4. **UP AND DOWN THE BROOKS.** By MARK E. BAMFORD.

With Illustrations. 16mo, 75 cents each.

Picturesque Alaska.

By ABBY JOHNSON WOODMAN. With an Introduction by J. G. WHITTIER, and Illustrations. 16mo, \$1.00.

Mrs. Woodman tells in an entertaining way her experiences and observations during a recent visit to Alaska, and gives no little information which will be useful to Alaska tourists.

HOUGHTON, MIFFLIN, & CO., Boston.

11 East Seventeenth Street, New York.

— A new magazine idea has been struck by *Scrivener's*, the July issue of which will be a fiction number for midsummer reading, containing seven complete short stories, bright, entertaining, and richly illustrated by skilful artists like Frederic Remington, Robert Blum, and Chester Loomis. The number will also contain the ninth instalment of Mr. Stevenson's "Master of Ballantrae," and the second article in the electric series. This last is by Charles L. Buckingham, the electrical expert and attorney for the Western Union, and is on "The Telegraph of To-day." This will be abundantly illustrated with views from the great operating-room of the Western Union in New York, from the main office of the Commercial Cable Company, and from other interesting sources. Telegraphing from moving trains and between ships at sea will be clearly explained.

— Messrs. Ginn & Co. announce for publication "A School Iliad, with Vocabulary," edited for schools by Professor T. D. Seymour of Yale College, author of "The Language and Verse of Homer," etc., with introduction, commentary, and illustrated vocabulary. Two editions will be published, — the first consisting of three books, to be ready June 20; and the second, of six books, to be ready some time this summer. The introduction presents, in brief but systematic form, the most important facts regarding Homeric life, the Homeric poems, Homeric style, syntax, dialect, and verse. The commentary is adapted to the wants of beginners in Homer. The notes are copious for the first three books. They are less copious for Books IV.–VI., but the commentary on Book VI. is fuller than that on Books IV. and V. The vocabulary is illustrated with more than twenty woodcuts, most of which are new in this country.

— Frederick Warne & Co. have now ready "Fifty Years on the Trail," a true story of Western life, by John Y. Nelson and Harrington O'Reilly, illustrated by Paul Frenzeny, who has also lived among the scenes in which this story of wild frontier life is laid. Nelson was an old-time scout, guide, and interpreter before cities and towns drove out Indians and buffaloes, and with the aid of his collaborator he has made a book of four hundred pages, which appears with appropriate cover-design.

— T. Y. Crowell & Co. publish the following important books, in paper covers, at fifty cents each, this month: "Ivan Ilyitch and Family Happiness" and "My Confession," two contrasting works by Count Lyof N. Tolstoj; and Dr. George Brandes' new book, "Impressions of Russia," which will throw fresh light on a very interesting subject.

— D. C. Heath & Co. will publish in September "A German Reader, for Beginners in School or College," by Edward S. Joynes, editor of the "Joynes-Meissner German Grammar."

— The Cambridge University Press, according to the London *Academy*, has now nearly ready for publication "The Collected Papers of Henry Bradshaw," the late university librarian, and a wonderful scholar.

— Roberts Brothers announce for fall publication "The Life of Louisa M. Alcott," by Ednah D. Cheney, her lifelong friend. Miss Cheney has written her biography of the author of "Little Women" in a manner to interest the youngest readers of that wonderfully successful book, who will eagerly read the story of Miss Alcott's home life, and her efforts to write stories for the boys and girls she loved so dearly. Two portraits will be included in the book.

— The July number of *The Chautauquan* presents as its opening article a study by Gen. H. V. Boynton on "Our National University," the city of Washington. Elizabeth Robins Pennell gives some advice about "Outings for Thin Pocket-Books." The "Sunday Readings" are selected by Bishop Vincent. Professor La-Roy F. Griffin of Lake Forest University furnishes a timely article on "The Art of Keeping Cool." Ida M. Tarbell sketches the life of Madame de Staël. A brief description of "Student Life in Germany" is given by F. M. Warren, Ph.D. Olive Thorne Miller continues her observations of bird-life, this time writing of their "Baby-Days." Professor A. P. Coleman, Ph.D., of Victoria University, relates some thrilling experiences of his while canoeing on the Columbia. "The Foreign Element and Prohibition" is the subject of a thoughtful article by the Hon. Albert Griffin, chairman

of the Anti-Saloon Republican National Committee. Bishop Mal-lalieu tells of his sight-seeing in holy Moscow. John Murdoch describes "Hunting and Fishing at Point Barrow." James K. Reeve suggests perfume flower-farming as "a home industry in which the surplus labor of a household could be profitably employed." "Chautauqua Life in 1800" is a valuable historical article by Francis Newton Thorpe, Ph.D. Ripley Hitchcock gives a delightful account of "Country Club Life," and interesting facts regarding "The Jews in the United States" are given by Philip Cowen.

— A. D. F. Randolph & Co. will publish at once "A New World Switzerland," by Victor Tisset, translated by Mrs. Wilson.

— The *Contemporary Review* for June (New York, Leonard Scott Publication Company, 29 Park Row) opens with a paper by Archbishop Walsh, entitled "Arbitration or the Battering-Ram?" in which he relates some of the leading incidents that have marked the course of his efforts in the cause of peace. The archbishop is an ardent advocate of the efficacy of arbitration, and he describes the progress made thus far by that method in settling the Irish question. Sir Morell Mackenzie contributes the first of two papers on speech and song, which, in view of the author's connection with the late Emperor Frederick, promise to possess exceptional interest. W. T. Stead, editor of the *Pall Mall Gazette*, contributes an article on "Madame France and her General," in which he treats of the rise, progress, and possible future of Boulanger. France, he argues, is wearied of the republic, and Boulanger is simply a distraction. The republic has committed many grave and glaring faults, especially the policy of colonial extension; the administration has been tainted with corruption; the government is intensely anti-clerical; and stupendous financial crises have happened under it. Frederick Greenwood traces the decline of English influence in continental politics in a paper entitled "The Mysteries of our Foreign Relations." Vernon Lee presents some irrelevant talks on the use of the beautiful, in a paper entitled "Orpheus in Rome." Edwin Hatch argues that the tendency of the present age has been to transfer the basis of theology from metaphysics to history. E. J. Goodman describes that well-known English institution the Savage Club, and tells some interesting stories in connection with it. G. B. Hill presents a somewhat novel view of Dr. Johnson's character in an article on "Dr. Johnson as a Radical." Sir William Dawson contributes a brief note, in which he defends himself on some of his views of Genesis. The number concludes with two papers on "The Volunteers," by C. B. Brackenbury and Lord Mayor Whitehead.

— The *Nineteenth Century* for June (New York, Leonard Scott Publication Company, 29 Park Row) opens with an appeal against woman suffrage, signed by a number of representative English women, including such names as Lady Frederick Cavendish, Lady Randolph Churchill, Mrs. Knox-Little, Mrs. Humphry Ward, Mrs. Huxley, Mrs. Lynn Linton, Mrs. Alma Tadema, Mrs. Matthew Arnold, and Mrs. Max Müller. Professor Edward Dicey presents a short but strong article on the "Ethics of Political Lying." Mlle. Blaze de Bury contributes the first of two papers on the "Theatre Francais and its Societaires," in which she traces the continuity of common interests which has kept this body together for two centuries, and explains Molière's ideas in creating it. In an article on "A Bird's-Eye View of India," Lady Grant Duff argues that India is a continent, not a people, and that its real characteristics are practically unknown in England. Lady Verney writes on "Six Generations of Czars," summarizing the personal history of the czars for the last two hundred years, and deducing therefrom the personal traits of the present ruler. Prince Krapotkin writes on the "Great French Revolution," which he regards as a necessity and the greatest moving force in modern history. He argues that the condition of the Russian peasantry to-day, compared with that of the French, is sufficient proof of the benefits wrought by the revolution. Mrs. Priestly writes on the "Mysteries of Malaria," reviewing the recent progress made in analyzing the disease. Edward Clifford, whose paper on "Father Damien and the Lepers" last month attracted so much attention, contributes an article on the "Hawaiians and Father Damien." Samuel Plimsoll presents some interesting facts on marine insurance, in an article which is a continuation of papers on the same subject in the March and April

numbers of the *Review*. The Rev. H. P. Dunster argues for an extension of the postal service, in a paper entitled "An Agricultural Parcels Post," in which he maintains that the post-office should give facilities for the distribution of food. E. N. Buxton contributes an eminently readable article on "Sardinia and its Wild Sheep," descriptive of a hunt in the wilds of Sardinia. Lord Ebrington describes a "By-Election in 1747," giving the full details of the expenses of parliamentary methods more than one hundred years ago, and throwing much light on early politics. The number concludes with a long essay by Professor Huxley on "Agnosticism and Christianity," written in his most characteristic vein, which forms an important contribution to the already extensive list of papers on this subject published in this *Review*.

— Messrs. Longmans, Green, & Co. send us the first number of the *New Review*, a magazine of ninety-six pages, which is sold for the low price of fifteen cents. The prospectus lays great stress on the eminence of the contributors that have been engaged, and conveys possibly the impression that the writer's name will be considered of more account than the quality of his work. However, the articles in this first issue are on the same level as those of its larger rivals, though some of them are too brief for a proper presentation of the subject treated. The opening paper, on "Gen. Boulanger," is the best, and will of course attract the most attention. It is in two parts. The first, written with the general's own authority and presenting his side of the case, is by Alfred Naquet of the French Senate; the second, presenting the opposite side, by Camille Pelletan of the French Chamber. It appears that the general's followers are animated by dislike of parliamentary government, and, though professing to be republicans, they really want a sort of dictatorship tempered by the *plébiscite*. French parliamentarism has not been so successful as might be wished, owing to the fact that the ministry are not at liberty to dissolve the Chamber and appeal to the people; but to seek a remedy, as M. Naquet would do, in the virtual abolition of parliamentary government, seems very unwise. M. Pelletan thinks the rise of Boulangerism an almost unaccountable phenomenon, but attributes it partly to the discontent which various classes feel towards the present government, and partly to the passion of the French people for a hero. It is plain, from the tone of the two articles, that the general's partisans are more hopeful than his opponents; and the outcome of the struggle will be looked for with much interest. The second paper in the *Review* is a rambling dialogue, "After the Play," by Henry James, designed as a critique of the contemporary drama. Earl Compton writes of "The Homes of the People," presenting anew the evils of the tenement-house system in cities, and advocating the erection of new and improved dwellings by the cities themselves. Lord Charles Beresford writes on "National Muscle;" Mrs. Lynn Linton, on "The Religion of Self-Respect;" and Mr. G. W. Russell, on "The Unionist Policy for Ireland." Mr. Russell's paper, though brief, is very suggestive, advocating measures for assisting the Irish tenants to purchase their holdings, and also a system of local government for Ireland similar to that already established in England. The concluding article is by Lady Randolph Churchill, detailing her observations during a month in Russia. It is written in a clear and simple style, and shows great keenness of observation, and will be sure to interest those who like to read about social life and customs. On the whole, the *New Review*, notwithstanding the brevity of some of its articles, promises to be a formidable rival of the older English reviews, as well as of some published in the United States.

— European scholars are devoting much attention at present to the centenary of the French Revolution and its influence upon European politics. The *Fortnightly Review* for June (New York, Leonard Scott Publication Company, 29 Park Row) opens with two papers on the Revolution,— the first, "What the French Revolution did," by Frederic Harrison, a brilliant and scholarly paper; and the second, by Gen. Viscount Wolsley, entitled "The French Revolution and War," in which he investigates the influence which that event exerted upon the science of warfare. The Marquis of Lorne presents a review of "Five Years' Advocacy of Provincial Parliaments," which he suggested some time since as a solution of the Irish difficulty; William Day, in a paper on "Turf Reform,"

argues for the necessity of devising fresh regulations, and instituting more stringent measures for purifying the turf and benefiting the whole racing community; E. C. K. Gonner writes on "The Foreigner in England," and maintains that there are many serious grievances arising from unrestricted immigration to England, calling for immediate action on the part of the authorities; Professor E. A. Freeman contributes a note on "The House of Hapsburg in South-eastern Europe," in which he questions some statements made by Mr. J. D. Bouchier in a paper on the same subject in the March number of the *Review*; Lady Dilke describes some benefit societies and trades unions for women,— a subject of much importance to all laboring women; Dr. Robson Roose presents some good and careful rules on the "Art of Preserving Life;" an anonymous writer criticises some recent changes made by the British Government in the matter of the Egyptian bonds; and Frederick Greenwood contributes an interesting sketch entitled "A Conversation in a Balcony." The number concludes with an eminently readable paper on "The Women of Spain," by Emilia Pardo Bazan.

LETTERS TO THE EDITOR.

*.*Correspondents are requested to be as brief as possible. The writer's name is in all cases required as proof of good faith.
The editor will be glad to publish any queries consonant with the character of the journal.

Cloud and Fog.

THE formation of cloud has been generally ascribed to the rising of a mass of saturated air to a cooler stratum, where the cooling due to expansion and that from the surrounding air produces a supersaturation and visible cloud. Not long since, Mr. John Aitken of Scotland propounded the rather startling theory that cloud could not be formed without the intervention of solid particles of dust, smoke, or other substance. This view was based on laboratory experiments, in which dust-free air seemed to show no condensation upon rarefaction. It would seem as though this view can hardly be possible. If two molecules of vapor have been sufficiently cooled, why may they not coalesce into a double molecule of water? If we consider that each double molecule of water needs a solid particle for a nucleus, there will be needed enormous quantities of these particles in each cloud, and more, it would seem, than can possibly be present in the cloud-forming strata.

A few experiments have been tried in cloud-formation, and a brief review of these is given here, the complete discussion and experimental proofs being reserved for another occasion. Most of the experiments were made with a clear glass water-bottle holding a half-gallon, and having three openings at the top. These were fitted with absolutely tight rubber stoppers having openings, which allowed the use of wet and dry thermometers to determine the moisture, and the use of glass tubes whereby the air could be compressed or exhausted at pleasure. An attempt was made to saturate the air by first passing it through a bottle of water; but, this not succeeding, it was passed through a bottle full of cracked pumice and water, a U-tube of the same, another U-tube having cotton soaked in water, and a straight tube with four inches of cotton (also wet). Near the compressor was a tube having three inches of dry cotton, and in the tube passing into the bottle there was another pledget of cotton. It was still found, after passing through this mass of moisture, that the air was not saturated, and it seems a practical impossibility to perfectly saturate air. Even after heating the bottle and tube of pumice nearly to boiling, the air was not saturated. It would seem as though this might explain in part the non-success of some former experiments in producing cloud in dust-free air.

Experiment 1.— Air was introduced into the bottle, as near saturated as possible, and then the whole was heated to 110°. The dry bulb rose a little faster than the wet. On suddenly cooling the outside, no cloud was observed, nor did the thermometers come together, but moisture was deposited on the sides.

Experiment 2.— The air was again heated to 110°, and it was mingled with nearly saturated air at about 65°. No cloud was observed.

Experiment 3.— The air was again heated, and a small piece of ice was suspended near the top. No cloud was observed, but a

beautiful white streak ran perpendicularly from the ice to the bottom, where it recurved, and finally disappeared in thin filaments. It was discovered that this was due to camphor-smoke purposely introduced. No appearance with ice was noted in dust-free air.

Experiment 4.—Nearly saturated air, with a little smoke, was compressed, and suddenly released from pressure. A haze filled the whole bottle.

Experiment 5.—On repeating this again and again, occasionally introducing a little smoke, it was found that the degree of saturation made little difference. Finally the haze was produced in air having a relative humidity of two per cent and a dewpoint of -21° , the outside air being at about 80° .

Experiment 6.—The bottle was filled full with water, removing every particle of air. All the dust-particles were driven from the compressor, and by it the water was forced out with air nearly saturated. On compressing this air, absolutely dust-free, and releasing it, a beautiful mist of clearly rounded water-particles was noted. The appearance was very different from the cloud-haze before noted, which had no rounded particles, but was an indefinite white haze. The difference between the two could not for a moment be mistaken.

Experiment 7.—On introducing a little smoke, the haze was very prominent at first; but, after a few compressions, the haze began to disappear, and there were seen together both haze and mist. The haze was finally entirely sifted out, but repeated compressions and expansions failed to change the mist in any way.

Experiment 8.—Dust-free air, nearly saturated, was suddenly expanded by an air-pump, and the mist appeared as before under compression, but was much shorter lived. No. 7 was also repeated with the air-pump, but the effects in all cases were less marked than under compression. It appeared in the air-pump experiment as though the mist formed at the top of the bottle, and it was feared that there might possibly be a leakage around the stoppers or tubes. This led to No. 9.

Experiment 9.—The bottle was filled full and inverted, great care being taken that not a particle of dust should get in. A little water was left at the bottom, and this formed a most effectual stop for all ingress of air. The air-pump gave the same mist as before.

The following are the proofs that the mist was formed in nearly saturated air without the intervention of solid particles of any kind: 1. The haze from dust or smoke was entirely different from the mist in dust-free air; 2. It was a very easy matter to sift out the smoke-haze by repeated compressions, but not so the mist; 3. The mist was the same so long as the compression and saturation remained constant (it was impossible to diminish this after hours of labor); 4. The mist settled down to the bottom after each compression, and finally moistened it with drops, showing that an enormous number of mist-globules had settled. If each mist-globule had taken a dust-particle along, it is easy to see that after a very short time every mote would have been deposited.

Conclusions.—1. It seems practically impossible to perfectly saturate air by cooling, by expansion, by mixture of cold and warm air, by passing through wet substances, or in any analogous manner. 2. This is probably the reason that no permanent haze cloud or mist has yet been formed by direct experiment. 3. Cooling by expansion or in any other way, and consequent condensation, is not needed to display invisible smoke or moisture particles. 4. The mixing of two bodies of air of widely different temperature, and nearly saturated, will not produce a cloud. 5. The sudden cooling of nearly saturated air will not produce a cloud. 6. A velocity of one hundred and more miles per hour of an ascending current will hardly suffice to produce cloud or mist by expansion in nearly saturated air. 7. It seems possible to unite smoke-particles so as to form visible haze in dry air. This may be a mechanical aggregation due to a violent bombardment of the particles on sudden expansion. 8. The same statement may be made of moisture-particles in nearly saturated air.

Some of these conclusions are very remarkable, and I sincerely trust that other experimenters will make the few simple trials needed. To one having access to a laboratory the whole expense will be practically nothing.

H. A. HAZEN.

Washington, June 21.

Osteological Notes.

PROFESSOR FLOWER, in his admirable hand-book on the osteology of the *Mammalia*, lays special stress on the disposition of the lateral bones of the cranium as constituting points of difference between the *Catarrhini* and *Platyrrhini*, the Old and New World monkeys.

On careful examination of the skulls in this museum in reference to this subject, I find that there are exceptions to almost every rule, that might be offered, and that authorities differed even on these exceptions. Notwithstanding these differences, however, it may be affirmed that (1) the *Catarrhini*, as is the rule in man, have the alisphenoid join suturally with the parietal and frontal, with one or both, or they may have the squamosal join with the frontal; (2) the *Platyrrhini* have the parietal and malar join suturally, thus preventing the union of the alisphenoid with the parietal and frontal, or of the union of the squamosal with the frontal.

It is generally taught that the *os planum* of the ethmoid enters into the formation of the inner wall of the orbit in man and apes only. Gegenbaur, on this point, says, "Except in some *Edentata*, it is in the Primates only that a portion of the lateral surface reaches to the median boundary of the orbit, where it forms the *lamina papyracea*." The great anatomist overlooks the *Felida* in the order of the *Carnivora*, in many of which family, as in the domestic cat (*Felis domestica*), in the tiger (*Felis tigris*), in the jaguar (*Felis onca*), and in the lion (*Felis leo*), as well as in several of the *Viverrida*, the *os planum* is distinctly visible in the wall of the orbit.

The perforation of the transverse processes of the seventh cervical vertebra by the vertebral canal, as also the presence of an articular cavity on the hinder edge of the body of this same vertebra for the reception of the head of the first rib, are distinctive characters in some of the orders of the *Mammalia*, and considerable importance has been laid upon their presence or absence in the matter of classification.

Seventh Cervical Vertebra.

Primates.	Transverse Process.	Articular Cavity.
Homo.....	Perforated	Absent.
Gorilla.....	"	Present.
Chimpanzee.....	Imperforate	"
Orang.....	"	"
Hylobates ¹	"	"
Carnivora.....	"	Absent.
Ungulata ²	"	Present.
Proboscidea.....	"	"
Cetacea.....	Imperfectly developed	"
Sirenia.....	"	"
Insectivora.....	Imperforate	"
Chiroptera.....	"	"
Rodentia ³	"	"
Edentata ⁴	"	"
Marsupialia.....	Perforated	"
Monotremata ⁵	"	"

¹ In the other primates the perforate or imperforate condition of the transverse process of the seventh cervical vertebra varies much. Mivart says that he has never seen it perforated in *Hylobates*, *Mycetes*, *Brachyurus*, *Nyctipithecus*, *Chrysothrix*, *Hapale*, *Lemur*, *Galago-arcotobus*.

² The giraffe has the seventh cervical perforated.

³ *Lepus* has the seventh cervical perforated.

⁴ In the Sloths the three-toed has the eighth cervical perforated, and the two-toed, the sixth cervical.

⁵ The *Echidna* has the seventh cervical imperforate, and the *Ornithorhynchus* has an articular cavity for first rib on the same.

The above table, based upon an examination of the articulated and disarticulated skeletons in this collection, may prove serviceable to those interested.

D. D. SLADE.

Mus. Comp. Zool., Cambridge, Mass., June 12.

GUARANTY INVESTMENT COMPANY

CAPITAL \$250,000.

Offices: Atchison, Kan. 191 Broadway, New York. 222 Walnut St., Phila.

Hon. ALBERT H. HORTON (Chief Justice, Kansas Supreme Court), Topeka, Kan., Pres't.

7% Guaranteed Farm Mortgages 7%

The Guaranty Investment Company makes loans upon fertile farms in the choicest portions of Kansas and Nebraska and has adopted the policy of sending a Committee of its Investors each year to examine its loans and methods of business.

The Committee this year consisted of PROF. A. H. BERLIN, Principal of the High School Montrose, Pa., and MAJ. THEODORE L. POOLE, Ex-U. S. Pension Agent, Syracuse, N. Y. Both of these gentlemen are persons of the highest character and have the confidence of the Communities in which they reside.

The Committee has recently returned and has made a very interesting Report upon the general development of Kansas and Nebraska as well as the business of the Company. The Company will be glad to send this Report to any address.

The following names are taken from the long list of Investors in our Mortgages:

(See if Some Friend of Yours is not in the List.)

William A. Caldwell, 59 Liberty St., N.Y.
 Palmer Cox, 658 Broadway, N.Y.
 Rev. Jos. H. Ryland, D.D., 11 Livingston Place, N.Y.
 Rev. Brady E. Backus, D.D., 360 West 28th St., N.Y.
 Rev. R. M. Sommerville, 126 West 43rd St., N.Y.
 Dr. Robert A. Murray, 274 West 23d St., N.Y.
 Dr. James P. Tuttle, 125 West 48th St., N.Y.
 H. Edwards Rowland, 218 Fulton St., N.Y.
 Irving H. Tift, Esq., 271 Broadway, N.Y.
 Prof. D. G. Eaton, 55 Pineapple St., Brooklyn, N.Y.
 Dr. E. P. Thwing, 126 St. Marks Ave., Brooklyn, N.Y.
 Dr. C. C. Miles, Greenport, N.Y.
 John V. N. Bergen, Fort Jefferson, N.Y.
 Benj. W. Schiell, Yonkers, N.Y.

R. C. Coleman, Goshen, N.Y.
 Mrs. Samuel Carlisle, Newburg, N.Y.
 Dr. C. C. Bartholomew, Ogdensburg, N.Y.
 Rev. Nelson Millard, D.D., Rochester, N.Y.
 Rev. Horace G. Hinsdale, D.D., Princeton, N.J.
 Dr. Charles M. Howe, Passaic, N.J.
 George A. Skinner, 5 Railroad Place, Newark, N.J.
 Dr. Edwin M. Howe, 85 Halsey St., Newark, N.J.
 Dr. H. G. Buckingham, Clayton, N.J.
 Dr. Martin Cole, Jr., Hainesville, N.J.
 Mortgage Trust Co. of Pa., Philadelphia, Pa.
 Miss Mary Miller, 1200 Spruce St., Philadelphia, Pa.
 Henry D. Biddle, 311½ Walnut St., Philadelphia, Pa.

Dr. Calvin C. Halsey, Montrose, Pa.
 Rev. William Baldwin, Great Bend, Pa.
 Gen. William Lilly, Mauch Chunk, Pa.
 Second Nat. Bank, Mauch Chunk, Pa.
 Enos E. Thatcher, West Chester, Pa.
 Mrs. Townsend Poore, Scranton, Pa.
 Rev. Burdett Hart, D.D., New Haven, Conn.
 Dr. Frank H. Wheeler, New Haven, Conn.
 Charles R. Christy, Stamford, Conn.
 Mrs. Catharine P. Fuller, Woodmont, Conn.
 Miss Jessie Henderson, Lenox, Mass.
 Dr. M. J. Halloran, Worcester, Mass.
 Albert Walker, Bennington, Vt.

Address for Report and Monthly Bulletin

HENRY A. RILEY, General Eastern Manager, 191 Broadway, N.Y.

ONE LANGUAGE FOR THE WHOLE WORLD.

WORLD-ENGLISH:

THE UNIVERSAL LANGUAGE. 25 CENTS.

EVERY one has heard of the butcher who, after a long search for his knife, at last found it in his mouth: so speakers of English have been seeking for a universal language, when, lo! it is in their mouths. The intelligibility of English words has been obscured by a dense mist of letters. This is now dispersed by A. Melville Bell, who has already won a world-wide reputation through his invention of "Visible Speech," the great boon to deaf-mutes. Professor Bell calls this new discovery of his "World-English," and the result is a language which cannot fail to meet with acceptance, and at once supersede the supposed necessity for "Volapük," or any other artificial language. No language could be invented for international use that would surpass English in grammatical simplicity, and in general fitness to become the tongue of the world. It is already the mother-tongue of increasing millions in both hemispheres, and some knowledge of the language is demanded by all educated populations on the globe. Social and commercial necessities require that the acquisition of this knowledge shall be facilitated, and it is believed that Professor Bell's invention has removed the last impediment to English becoming the universal language, for which vague desires have long been entertained, although hitherto only futile efforts have been made.

Ex-President Andrew D. White, of Cornell University, says: "I believe that the highest interests of Christian civilization and of humanity would be served by its adoption. China and Japan would be made English-speaking peoples within fifty years, and so brought within the range of Christianizing and civilizing ideas, in the largest sense. All existing missionary work is trivial as compared with this. For your system would throw wide open those vast countries, as, indeed, all the countries of the world, to the whole current of English and American thought."

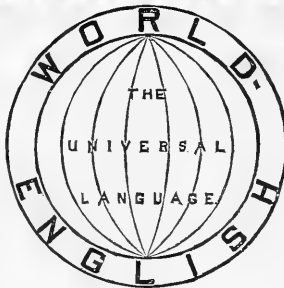

For Diffusion of English throughout the World

AS THE UNIVERSAL LANGUAGE

This "Hand-Book of World-English" is the Complete, Simple, and Efficient Medium.

FOREIGNERS

Will Acquire, by Means of this Hand-Book, a PERFECT PRONUNCIATION OF ENGLISH.

For Primary School Pupils and Illiterate Adults

World-English is a Royal Road to Reading.

To Teachers of English and Modern Languages

This Hand-Book will be of Primary Importance as a Phonetic Directory.

DEFECTS OF SPEECH

Will be Readily Corrected by Means of the Articulate Directions in this Hand-Book.

HAND-BOOK OF WORLD-ENGLISH,

25 CENTS.

The plan of this little book is altogether new. Letters and sounds are so associated, in all the exercises, that from the mere knowledge of letters a learner cannot fail to pronounce words with certainty. English reading will thus be easily acquired, whether by natives or foreigners, children or adults.

The general resemblance of World-English to Literary English is such that any reader of the latter decipheres the former at sight, or, at most, after a few minutes' study of the new letters. A like result may be anticipated for those who shall learn to read from World-English. They will transfer their power of reading to the literary form of the language, almost without effort. The orthographic aspect of words will, besides, be so fixed in the eye, by contrast, that spelling will be remembered as — what it really is — a pictorial association with words.

No special training is required to qualify teachers for using this book. The subject can even be successfully introduced in the kindergarten and the nursery. This phonetic mode of initiation in reading cannot be too strongly urged on the attention of School Boards on both sides of the Atlantic.

The ordinary orthography of each word is interlined with the World-English version throughout the Exercises and Readings.

So set down, our tongue is the best for the world to unite upon.—*Brooklyn Eagle*.

The idea of Mr. Bell has much to recommend it, and the presentation is charmingly clear.—*American*, Phila.

The result is a language which cannot fail to meet with acceptance.—*Boston Traveller*.

Has the merit of great ingenuity.—*Railway Age*.

His treatise, as a study of English orthoepy, condenses the result of much thought and experience in small compass.—*The Critic*.

World-English deserves the careful consideration of all serious scholars.—*Modern Language Notes*.

World-English is the English language unburdened of its chaotic spelling.—*Popular Science Monthly*.

We commend it to the attention of teachers.—*Ottawa Globe*.

"World-English" and "Hand-Book of World-English" can be had of all booksellers, or will be sent for 50 cents, post free, by the publisher,

N. D. C. HODGES, 47 Lafayette Place, New York.

DAFT ELECTRIC LIGHT COMPANY.

Power Stations.

Stationary Motors

1/2 to 100 H.P.

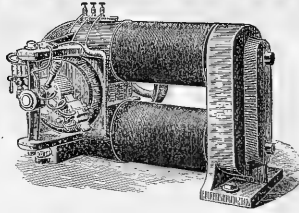

Electric Railways.

Car Motors 15 to

250 H.P.

Executive Office, 115 Broadway, N.Y.
 FACTORY, JERSEY CITY, N. J. Please Mention "Science."

Any one who will have the following blank filled out by a responsible Newsdealer, and mailed to us, will be allowed a three months' subscription to *Science*.

N. D. C. HODGES,

47 LAFAYETTE PLACE, NEW YORK.

SCIENCE CLUBBING RATES.

	10% DISCOUNT.		
	Year's Subscription.	With Science.	With The Swiss Cross.
Agricultural Science.....	\$ 2.50	\$ 5.30	\$ 4.50
American Agriculturist.....	1.50	4.30	2.50
American Architect and Building News.....			
Imperial edition.....	10.00	12.80	11.00
Gelatine ".....	7.00	9.80	8.00
Regular ".....	6.00	8.80	7.00
American Garden.....	1.00	4.25	2.25
American Journal of Philology.....	3.00	6.25	4.25
American Machinist.....	2.50	5.30	4.50
American Naturalist.....	4.00	7.50	5.50
Andover Review.....	4.00	6.80	5.00
Atlantic.....	4.00	6.80	5.00
Babyhood.....	1.50	4.30	2.50
Bradstreet's.....	5.00	7.80	6.00
Brain.....	3.50	6.30	4.50
Building (weekly).....	6.00	8.80	7.00
Carpentry and Building.....	1.25	4.25	2.25
Century Magazine.....	4.00	6.80	5.00
Chautauquan, The.....	1.50	4.30	2.50
Christian Union, The.....	3.00	5.80	4.00
Cosmopolitan, The.....	2.00	4.80	3.00
Critic.....	3.00	5.80	4.00
Eclectic Magazine.....	5.00	7.80	6.00
Edinburgh Review.....	4.00	6.80	5.00
Electrical World.....	3.00	5.80	4.00
Electrical and Electrical Engineer.....	3.00	5.80	4.00
Electrical Review.....	3.00	5.80	4.00
Engineering and Mining Journal.....	4.00	6.80	5.00
English Illustrated Magazine.....	4.00	6.80	5.00
Forest and Stream.....	4.00	6.80	5.00
Forum, The.....	5.00	7.80	6.00
Harper's Bazar.....	4.00	6.80	5.00
Harper's Magazine.....	4.00	6.80	5.00
Harper's Weekly.....	4.00	6.80	5.00
Harper's Young People.....	2.00	4.80	3.00
Illustrated London News (Amer. reprint).....	4.00	6.80	5.00
Independent, The.....	3.00	5.80	4.00
Iron Age (weekly).....	4.50	7.30	5.50
Journal of Philology (Eng.).....	2.50	5.30	3.50
Judge.....	4.00	6.80	5.00
L'Art.....	12.00	14.80	10.00
Life.....	5.00	7.80	6.00
Lippincott's Magazine.....	3.00	5.80	4.00
Littell's Living Age.....	5.00	7.80	6.00
London Quarterly.....	4.00	6.80	5.00
Macmillan's Magazine.....	3.00	5.80	4.00
Magazine of American History.....	5.00	7.80	6.00
Medical and Surgical Journal.....	5.00	7.80	6.00
Mechanical Engineer.....	5.00	7.80	6.00
Metal Worker.....	1.00	4.25	2.25
Microscope, The.....	1.00	4.25	2.25
Nature.....	6.00	8.80	7.00
North American Review.....	5.00	7.80	6.00
Outing.....	3.00	5.80	4.00
Overland Monthly.....	4.00	6.80	5.00
Quarterly Science Journal.....	3.00	5.80	4.00
Popular Science Monthly.....	4.00	6.80	5.00
Popular Science News.....	1.00	4.25	2.25
Portfolio, The.....	7.50	10.30	8.50
Practitioner.....	6.00	8.80	7.00
Public Opinion.....	3.50	6.30	4.50
Queries.....	2.00	5.80	4.00
Puck.....	5.00	7.80	6.00
Puck (German).....	5.00	7.80	6.00
Quarterly Review (London).....	4.00	6.80	5.00
Scientific American.....	3.00	5.80	4.00
Supplement.....	5.00	7.80	6.00
Architect and Builders' edition.....	2.50	5.30	3.50
Scribner's Magazine.....	3.00	5.80	4.00
Texas Sittings.....	4.00	6.80	5.00
Trained Nurse.....	1.50	4.30	2.50

..... 1889.
 To the News Company.

You may add to my regular order five copies of SCIENCE each week (returnable).

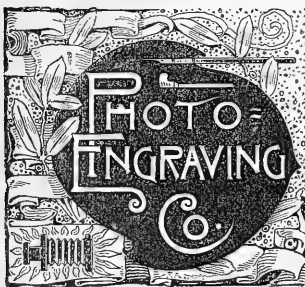

JOHN HASTINGS = A=R=MART = JOS=TRIPP
 P'rest. Gen' Managers V P'rest.
ENGRAVING FOR ALL ILLUSTRATIVE AND ADVERTISING PURPOSES

BRANCH AT 728 CHESTNUT ST. PHILADELPHIA, PA.

67-7 PARK PLACE, NEW YORK.

INDUSTRIAL NOTES.

Electric Shell Hoist for War-Vessels.

We publish in this issue of our paper a view of one of the electric hoists built by the Sprague Electric Railway and Motor Company of New York, for the new United States cruiser "Atlanta." This hoist is the first of its kind that has been built for this work, and this commencement of the use of electric power on shipboard is most novel, and promises to extend rapidly. The advantages of electric power for the manifold uses on board vessels, over transmission of power by steam to different portions of the vessel, are many, and the general adoption of incandescent lighting on shipboard enables such motors to be operated without additional dynamo installation.

The hoist which we illustrate is of three horse-power, using the regular Sprague graphite brushes, and can be run forwards or backwards with the greatest facility by the simple movement in one direction or another of an electric switch. By means of this same switch the speed can be varied to any degree desired.

Although built for the special purpose of hoisting shells, this

New York, 50 incandescent; Lawrence Line Company, Lawrence, Mass., 50 incandescent; Riverside Mills, Providence, R.I., 25 incandescent.

The Complete Combustion Boiler.

Mr. Francis E. Galloupe, mechanical engineer, tested the evaporative performance of a 100-horse-power steam-boiler having the downward draught furnace, at the works of the Suffolk Cordage Company, Chelsea, Mass., Feb. 25.

The boiler tested was a horizontal, cylindrical, multitubular boiler, and did not differ in design, either of the general construction or portions occupied by the water and steam, from that of the ordinary form, except in the furnace. The furnace is built of steel plates riveted like those of the shell, and is placed entirely within the shell of the boiler, and surrounded by water spaces. At the back end of the grate a hanging water-leg of steel plates, riveted to the crown sheet of the furnace, extends downward to within eighteen inches of the ash-pit or furnace bottom. The grate is formed of water tubes entering the front side of the water-leg, at the back end of the grate, at a moderate inclination from the hori-

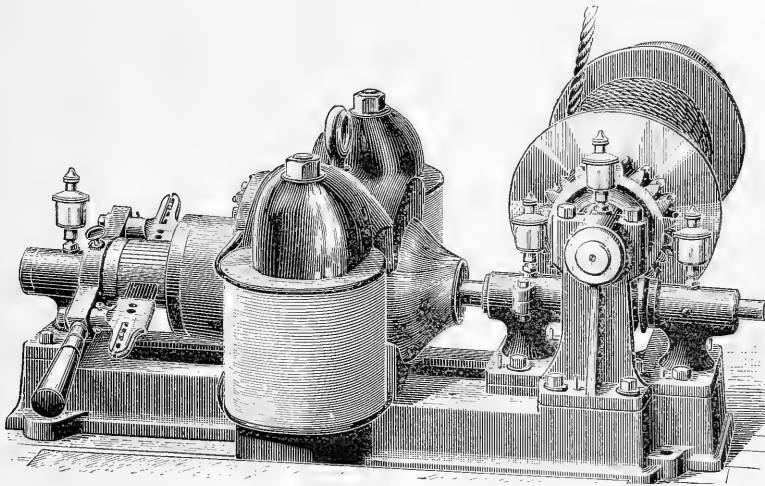

SPRAGUE ELECTRIC SHELL HOIST.

combination promises to meet a large demand for small hoists in manufacturing and other industries, where the small space occupied by an electric motor is quite a desideratum.

The tendency among the leading electric supply companies seems to be gradually towards electric motor combinations with other machines, like the above; and experience shows that such combinations create a demand as their advantages become recognized.

New Electric-Light Plants.

The Thomson-Houston Electric Company reports the following sales: Narragansett Pier, R.I., 30 arc, 1,000 incandescent; Seattle, W.T., 50 arc; Brockport, N.Y., 20 arc; Troy, O., 50 arc; Somerville, Mass., 100 arc; Binghamton, N.Y., 150 arc; Philadelphia, Penn., 100 arc; Lowell, Mass., 50 arc; Boston, Mass., 1,000 alternating; Springfield, Mass., 90 arc; Minneapolis, Minn., 150 arc, 1,200 incandescent; Rochester, N.H., 50 arc; Chelsea, Mass., 100 arc; Norwich, Conn., 400 incandescent; Goldsboro, N.J., 45 arc, 600 incandescent; Sorrento, Me., 30 arc. They also report the following isolated plants: Wamsutta Mills, New Bedford, Mass., 400 incandescent; Bennett Manufacturing Company, New Bedford, Mass., 600 incandescent; Whittle & Hanrahan, Providence, R.I., 15 arc; H. Ricker & Sons, Poland Springs, Me., 12 arc; Jewell Milling Company, Brooklyn, N.Y., 300 incandescent; M. W. Hyer,

zontal, and enters a gun-metal box in front, just below the furnace doors. Return tubes, also inclined, extend from this box beneath the grate tubes back to the water-leg, and insure a circulation of water from the main shell and water-leg, through the grate tubes. The space beneath the grate, ordinarily the ash-pit, is the combustion-chamber, the air for combustion being admitted through the fire-doors above the grate, and drawn down through the grate-bars by the chimney draught, where it becomes highly heated before or during its combination with the hot gases from the coal. Beyond the water-leg, extending up to the crown sheet of the furnace, is an extension of the combustion-chamber, which forms the passage to the tubes, the tube sheet being eighteen inches horizontally from back of the water-leg. The hot gases pass from this point through the tubes, which form a large absorbing area, directly to the uptake and chimney.

The position and arrangement of the furnace resemble that in the locomotive boiler, with the addition of a deflecting arch, which tends to mix the hot gases on their way to the tubes, and, as would be expected from this construction of an internal furnace entirely surrounded by the water-heating surfaces of the boiler, the boiler made steam very quickly, and almost immediately on lighting the fire.

During the trial a large Brown engine, stated to have been developing about 210 horse-power, was run by the steam from the

boiler under test, in connection with one other boiler of usual form; and although all the machinery of the works, including about 35 horse-power used in running generators for electric lights, was thrown on the engine, no difficulty was found in holding the steam-pressure required, with the flue damper one-third open, and fire-doors closed or placed ajar for a considerable portion of the time. The boiler showed considerable reserve capacity for an increase of power, whenever a demand was made upon it.

In the matter of safety it would seem that this construction is safer than the ordinary form. The crown sheet over the furnace has usually the least depth of water over it of any plate in a boiler exposed to the action of the fire, and is at the same time exposed to the fiercest temperature of the fire. The result of low water, should the crown sheet not be covered, would be, in the ordinary case, to burn the plate, with a resulting bulging of the sheet, or

great a quantity of air, which would be heated and wasted; or (3) by too strong a draught in the flue to the chimney, which would take off the hot gases before there was time for the absorption of their heat by the boiler. At the beginning of the test, the flue damper was open, and the temperature in the uptake was 590° F. On closing the damper to about one-third opening, at which point it was kept during the remainder of the trial, temperatures varying from 330° to 375° F. were obtained. At the steam-pressure carried, the temperature of the steam and water in the boiler was about 330° F., showing that the loss of heat above this temperature through the chimney was very small, varying from nothing to at no time more than about 40° F.

The firing was skilfully managed, and, so far as could be determined, no unnecessary amount of air was admitted. The percentage of refuse to the coal burned (9.91) shows that the coal, which

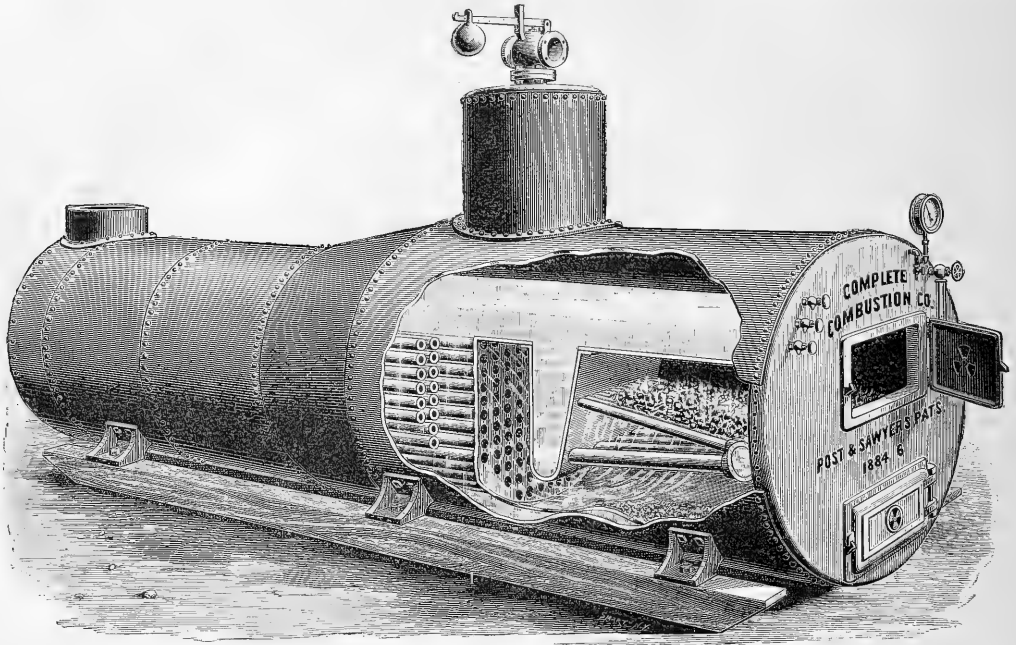

COMPLETE COMBUSTION BOILER.

perhaps the explosion of the boiler. In this boiler the hottest temperature of the fire is beneath the grate, where all the surrounding surfaces are protected by water, which instantaneously absorbs the heat coming in contact with them; while the direction of the draught being downward and away from the crown sheet, and the latter being still further cooled by the entering air used for combustion, the crown sheet is kept comparatively cool, with, in any case, little probability of burning. Should the water-level be lowered below the grate, the grate-tubes would burn off, and destroy the fire.

An important advantage in supplying the air above the grate is that it is never necessary to open the combustion-chamber to the outside air, which cools the entire boiler, and causes loss of heat in the ordinary boiler whenever the furnace is fired. Throughout the trial the ash-pit doors were kept closed.

The boiler was covered with asbestos, brick setting being unnecessary on account of the use of the internal furnace. Since the radiation from the steam and water surfaces of the boiler was reduced by the covering to a minimum, the only losses of heat that could occur were either (1) by not supplying air in the right quantity or manner to consume the coal perfectly; (2) by admitting too

was the best dry Cumberland to be had, was quite perfectly consumed.

From the above considerations and conditions, it would be expected that this boiler, properly run, would give high economical results. These were an evaporation from an average temperature of 53½° F. into steam of an average gauge pressure of 80 pounds, of 9.82 pounds of water per pound of coal. The equivalent evaporation, reduced to the standard of from and at 212° F. was 11.78 pounds, and per pound of combustible, 13.08 pounds. The average result of a large number of tests made with different boilers at the Centennial Exhibition of 1876 was 10.99 pounds of water per pound of combustible.

The boiler shows, as above, good proportions; and the conditions of setting, draught of chimney, etc., were favorable. The steam appeared to be of excellent quality, free from moisture, and there was no priming. The coal was charged as dry coal, no deduction being made for moisture. The water-consumption was accurately obtained by weighing all the water fed to the boiler, and there was no leakage. The water-level in the boiler was the same at the beginning and end of the test, and the steam-pressure made uniform at both times.

C. & C. ELECTRIC MOTOR COMPANY.

Electric Motors
FOR
Arc and Incandescent
Circuits, Most Eco-
nomical Motor on
the Market.
Regulation Perfect.
Motors Designed for all
Power Purposes.

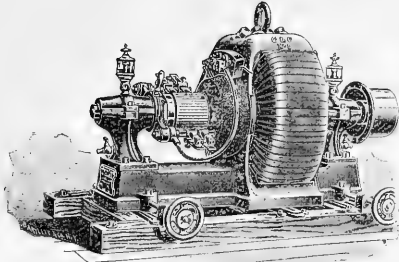

OFFICE and MANUFACTORY:
402 and 404 Greenwich Street, New
York City.
New England Office, 19 Pearl St., Boston.
Philadelphia Office, 301 Arch St.
Western Office, 139-141 Adams Street,
Chicago.
Southern Office, 25 Carondelet Street,
New Orleans.

"The Week, one of the ablest papers on the continent."—*Descriptive America.*

ENLARGED AND IMPROVED.

THE WEEK:

A Canadian Journal of Politics, Literature, Science and Arts.

PUBLISHED EVERY FRIDAY.

\$3.00 per Year. \$1.00 for Four Months.

THE WEEK has entered on its SIXTH year of publication, greatly enlarged and improved in every respect, rendering it still more worthy the cordial support of every one interested in the maintenance of a first-class literary journal.

The independence in politics and criticism which has characterized THE WEEK ever since its first issue will be rigidly maintained; and unceasing efforts will be made to improve its literary character and increase its value and attractiveness as a journal for the cultured home. Many new and able writers are now, or have promised to become, contributors to its columns, and the constant aim of the Publisher will be to make THE WEEK fully equal to the best literary journals in Britain and the United States.

As heretofore, PROF. GOLDWIN SMITH will, from time to time, contribute articles. London, Paris, Washington and Montreal letters from accomplished correspondents will appear at regular intervals. Special Ottawa Letters will appear during the sessions of Parliament.

THE WEEK in its enlarged form will be the same size as "Harpers Weekly," and the largest paper of its class on the continent.

SEND FOR FREE SAMPLE COPY.

C. BLACKETT ROBINSON, Publisher,
5 Jordan St., Toronto.

A NEW MAGAZINE—THE SWISS CROSS
Devoted to spreading a love of nature among the people. Edited by HARLAN H. BACLAND, President of the Agassiz Association, and succeeding *St. Nichol* as the official magazine of that body. \$1.50 a year. Sample copy 10 cents, or 25 cents for trial subscription for 3 months.
N. D. C. HODGES, PUBLISHER,
Mention this magazine 47 Lafayette Place, New York.

Wants.

A YOUNG MAN can have lucrative engagement, not only a fixed salary, but according to his work accomplished in travelling for SCIENCE. A personal interview invited.

N. D. C. HODGES,
47 Lafayette Place, New York.

MECHANICIAN.—An optician and maker of instruments of precision of experience would be glad of a position where his skill would be valued in connection with some higher educational institution. Address G. J., care of SCIENCE, 47 Lafayette Place, New York.

Scientific Apparatus.

J. GRUNOW,

621 Sixth Avenue, New York.
Established 1852.

MAKER OF

Microscope Stands,
Oil Immersion Objectives and Abbe Condensers for Bacterial and Histological work, of Objectives, Camera Lucida and other accessory apparatus.

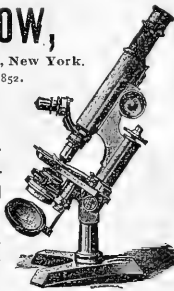

MORRIS EARLE & CO.
SUCCESSORS TO

R. & J. BECK,

1016 Chestnut Street, Phila.

Microscopes and all Accessories and Apparatus. Photographic and Photo-Micrographic Apparatus and Outfits.

Spectacles, Eye Glasses, Opera and Marine Glasses, etc.

Illustrated Price List mailed free to any address. Mention SCIENCE in corresponding with us.



IMPROVED OIL LIGHT MAGIC LANTERNS.

Also Lime and Electric Light Apparatus, and mechanical, plain, and fine colored views.

J. B. COLT & CO., Manufacturers,

No. 16 BERMAN STREET, NEW YORK.



E. & H. T. ANTHONY & CO.
591 Broadway, N.Y.

Manufacturers and Importers of PHOTOGRAPHIC INSTRUMENTS,

Apparatus and Supplies of every description. Sole proprietors of the Patent Detective, Fairy No. 1, and Bicycle Cameras, and the Celebrated Stanley Dry Plates.

Amateur outfits in great variety, from \$5.00 upward. Send for Catalogue or call and examine. More than 40 years established in this line of business.

Readers of Science

Corresponding with or visiting Advertisers, will confer a great favor by mentioning this paper.

A few of the earlier bound volumes of "Science" (slightly "shop-worn") for sale at \$1.25 per volume. Mailed post-paid within the United States on receipt of price.

N. D. C. HODGES, 47 Lafayette Place, New York.

ELECTRICAL TESTING BUREAU,

Johns Hopkins University, Baltimore, Md.
Resistance Coils and Boxes Compared.
Am meters and Volt meters calibrated.
Condensers standardized.
Primary and Secondary Batteries Tested.
Efficiency of Dynamos and Motors Determined.

Insulation of Cables and Wires Tested.
Etc., Etc.
Circulars describing Methods Used, Prices, Etc., sent on Application.
Address as above.

A TEMPORARY BINDER

for Science is now ready, and will be mailed postpaid on receipt of price.

Half Morocco - 75 cents.



This binder is strong, durable and elegant, has gilt side-title, and allows the opening of the pages perfectly flat. Any number can be taken out or replaced without disturbing the others, and the papers are not mutilated for subsequent permanent binding. Filed in this binder, *Science* is always convenient for reference.

N. D. C. HODGES,

47 Lafayette Place, New York.

Sprague Electric Railway and Motor Company.

Lightest Weight Consistent with
Highest Efficiency.

SIMPLE IN CONSTRUCTION.

Not Liable to get out of Order.

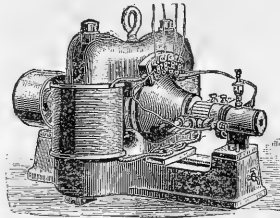

Bearings Self Oiling,
NON-SPARKING IN OPERATION.
Commutator Wear Reduced
to a Minimum.

16 and 18 BROAD STREET, NEW YORK.

The Mutual Life Insurance Company

OF NEW YORK.

RICHARD A. McCURDY, PRESIDENT.

ASSETS - - - \$126,082,153 56

The Largest and best Life Insurance Company in the World.

The New Business of the Mutual Life Insurance Company in 1888

Exceeded \$103,000,000.

Its Business shows the Greatest Comparative Gain made by
any Company during the past year including

A gain in assets of.....	\$ 7,275,301 68
A gain in income of.....	3,096,010 06
A gain in new premiums of.....	2,333,406 00
A gain in surplus of.....	1,645,622 11
A gain in new business of.....	33,756,792 85
A gain of risks in force.....	54,496,251 85

The Mutual Life Insurance Company

Has Paid to Policy-holders and Beneficiaries \$272,481,839 82.



**KIMBALL'S
STRAIGHT CUT
CIGARETTES.**

Unsurpassed in quality.
Used by people of refined taste.
Highest award at Brussels, 1888.
The finest smoking mixtures are of
our manufacture.
Fifteen First Prize Medals.
Wm. S. KIMBALL & CO.
Rochester, N.Y.

IMPROVING THE MEMORY PICK

and facilitating the acquirement of knowledge by
lectures and correspondence. Classes forming,
"MEMORY and its Doctors," from Simonides to
"Loisette," mailed for 25 cents (New Edition).

DR. PICK, 24 Union Square, N. Y. City.



GOOD NEWS TO LADIES.

Greatest improvements ever of-
fered. Now's your time to get
up orders for our celebrated
Teas and Coffees, and secure
a beautiful Gold Band or Moss
Rose China Tea Set, Dinner Set,
Gold Band Moss Rose Toilet Set, Watch, Brass Lamp,
or Webster's Dictionary. For full particulars address
THE GREAT AMERICAN TEA CO.
P. O. Box 239. 31 and 33 Vesey St., New York.

OUR 75 CENT COLORED SILK.

We have had unusual success
with this line of Gros Grains.

They are 19 1-2 inches wide, have
a fine cord weave, and are in 40
different, excellent shades. Under
ordinary circumstances they would
sell for \$1 per yard.

Send for samples; they will surely
please you.

JAMES McCREERY & CO.

BROADWAY AND ELEVENTH STREET,
NEW YORK.

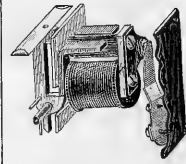

A
★
DROP
IN THE
PRICE
OF

GRAVITY

DROP

ANNUNCIATORS.

DON'T FORGET THE
DUST-PROOF BELLS.

HAZAZER & STANLEY,

32 Frankfort Street, N. Y.

SOMETHING NEW
THE PATENT
ADJUSTABLE BRUSH.

Patent Pocket Com. No waste.

THE STRONGEST
GLUE
2 GOLD MEDALS
IN THE WORLD.
LONDON 1883 & 1884
RUSSIA
NEW ORLEANS
1884
Stouffer's Make

LIQUID GLUE
ALWAYS
READY FOR USE
MANUFACTURED BY
THE PATENT BRUSH CO.
NEW YORK, U.S.A.

Repairs Everything.
Its success has brought a lot of
imitators copying us in every way
possible. Remember that THE
ONLY GENUINE LePage's Liquid
Glue is manufactured solely by the
RUSSIA CEMENT CO.
GLOUCESTER, MASS.
Send 10c. and dealers' card who
don't keep it in stock, for sample.

FOOD ADULTERATION

And its Detection. With photomicrographic plates and
a bibliographical appendix. By J. P. Battershall, 328
pages, 8vo, cloth. Price, \$3.50. Circulars and Catalogues
on application. E. & F. N. SPON,
12 Cortlandt St., New York.



SCIENCE

[Entered at the Post-Office of New York, N.Y., as Second-Class Matter.]

A WEEKLY NEWSPAPER OF ALL THE ARTS AND SCIENCES.

SEVENTH YEAR.
VOL. XIII. No. 334

NEW YORK, JUNE 28, 1889.

SINGLE COPIES, TEN CENTS.
\$3.50 PER YEAR, IN ADVANCE.

A GOOD RECORD FROM ATLANTIC CITY.

THE road which has been running upon the Sprague electric system at Atlantic City, N.J., continues to be visited by a large number of street-railway men from all parts of the country, and electricians and others interested in electric traction. A record of the operation of this road since the first cars were started shows that a grand total of 6,464 separate trips have been taken by the cars in operation upon this road. During this time, and in spite of the fact that the motors used upon this road were of the new Sprague type, which had hitherto not been tried upon any road, not a single

order has been increased to sixteen electric cars, each capable of drawing an additional car.

One noticeable characteristic of this road is the extremely light and ornamental character of the overhead system. The poles are of iron throughout the entire length of the line, and are placed between two tracks, using the double-bracket method of support for the trolley-wire. These poles, which were put up by the Pennsylvania Railroad Company, show how unobjectionable a system using overhead wires may be when sufficient regard is paid to this feature of the system.

The accompanying engraving gives a view of one of the Sprague



SPRAGUE ELECTRIC RAILWAY AT ATLANTIC CITY, N.J.

trip was lost by the electric cars. This is a record which it would be hard to duplicate in the records of any other machine used for the first time, and it is only additional evidence toward showing the superiority of the electric motor in simplicity, efficiency, and durability to other types of machines, and the care with which the leading electric supply companies are building their apparatus. The original order of the Pennsylvania Railroad Company, which controls the system of street-railways at Atlantic City, was for six cars, each to be equipped with two 15-horse-power Sprague motors, and each to be capable of drawing an ordinary street-car. Since the demonstration of its successful operation at Atlantic City, this

electric cars in operation at Atlantic City, N.J., drawing one ordinary car.

At the annual meeting for the election of fellows of the Royal Society, London, on June 6, the following were elected: John Aitken, Dr. Edward Ballard, Alfred Barnard Basset, Horace T. Brown, Latimer Clark, Professor David Douglas Cunningham, Lazarus Fletcher, William Botting Hemsley, Charles Thomas Hudson, Professor Thomas McKenny Hughes, Edward B. Poulton, Professor William Johnson Sollas, Charles Todd, Herbert Tomlinson, Professor Gerald F. Yeo.

THE CLARK ELECTRIC COMPANY'S APPARATUS.

The accompanying illustrations show the new apparatus of the Clark Electric Company. The dynamo shows some points of interest in details. It has an unusually long and deep commutator, provided with two independent brushes on each side, either one of

sent not only to the outside of the armature, but to its inner surface as well; and by this means an enormous increase of the polar surface is secured, which is claimed to render the wire cores more effective than a sheet-iron core. The machines are shunt wound, and are claimed to be the only high-tension arc-light machines so constructed. They are calculated throughout to secure the highest

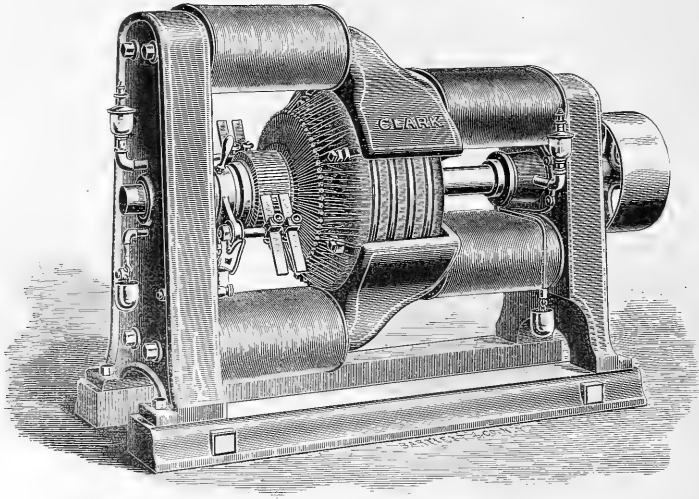

CLARK ELECTRIC COMPANY'S DYNAMO.

which is able to carry the current, thus allowing the brushes to be changed or turned over while the machine is in operation. The shaft is very strong, being made of cast steel, and runs in gun-metal bearings. The armature cores are made of cotton-insulated iron wire wound into the proper form. A better division of the

possible efficiency, and it is stated that after a long run no portion of the machine is ever found uncomfortably warm to the hand.

The principles on which the Clark automatic regulator works will need a word of explanation. The dynamos made by the Clark Company are shunt wound; and instead of using an adjustable

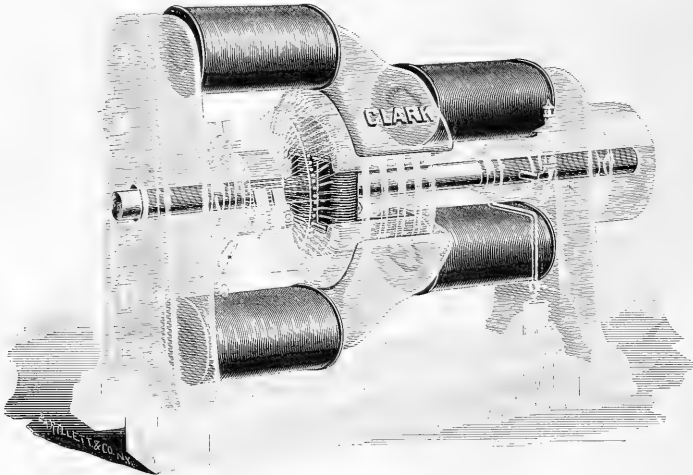

CLARK ELECTRIC COMPANY'S DYNAMO, SHOWING INTERIOR FIELD.

iron is thus obtained than by making the cores of sheet-iron rings with insulating material between them; but, as the core in this method of construction is laminated in both directions instead of only in one, its magnetic resistance is somewhat increased, which is a serious objection to such cores in most machines. In these machines, however, the pole-pieces of the field-magnets are pre-

rhostat in the field-magnet circuit, as is the usual practice with machines of this class, the exciting current is varied by means of an adjustable counter electro-motive force. This is accomplished as follows: the armature of the small regulating-machine shown in the cut is included, by means of its brushes and commutator, in the field-magnet circuit of the dynamo. This armature is of the Sie-

mens type, but wound with a large number of turns of fine wire, as the current passing through it is very small, in the arc machines never exceeding .4 of an ampère. When the current passes through the circuit, the armature revolves, and the machine becomes a motor, of course setting up a counter electro-motive force, the amount of which will depend upon the velocity of revolution of the armature, and the strength of the field in which it revolves. The speed of the armature is limited to a certain number of revolutions per minute by means of a small belt running from the pulley on the armature shaft to another one on the dynamo shaft, or on a line shaft, or some other revolving shaft whose speed is constant. As the speed of the armature cannot change, its counter electro-motive force can only change by reason of a change in the magnetic strength of its field-magnets. The main current, on its way to the

cut. It consists of a solenoid, located in the main circuit, whose armature is attached to a lever. The other end of this lever carries a sliding contact piece, which slides over a number of sections or contacts of copper. A number of small spirals of german-silver wire are connected to these contacts, and arranged so as to form an adjustable shunt for the field-coil of the regulator, whose resistance in the 30-light regulator is only .15 of an ohm. By means of this arrangement, when the main current falls a trifle, the resistance of the german-silver coils is diminished, and a greater portion of the main current is shunted through them, instead of pass-

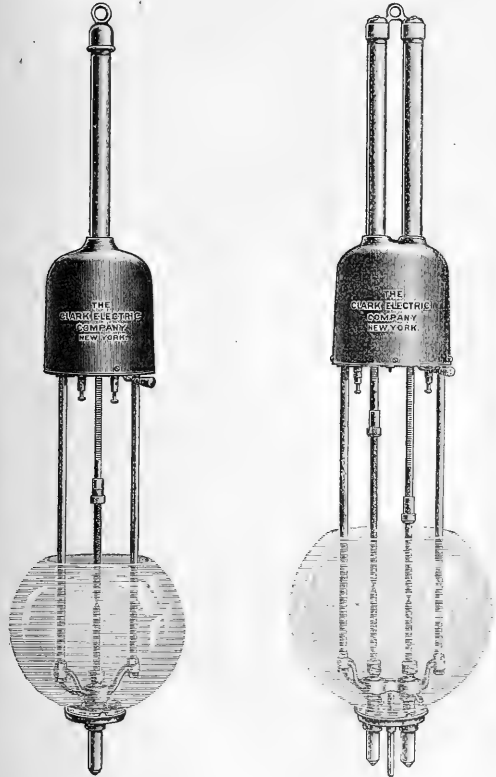

CLARK ELECTRIC COMPANY'S LAMPS.

line, passes through the coils of the regulator field-magnets, and thus supplies the field in which the regulator armature revolves. If from any cause the main current should increase in strength, it will at once cause an increase in the power of the field of the regulator, and an increase in the counter electro-motive force of its armature, which, being opposed to the exciting current of the dynamo field, reduces that current at once, and with it the strength of the magnetic field of the dynamo. This at once reduces the generating power of the dynamo, and brings the current back once more to its standard strength. If the strength of the main current should decrease for any reason, the opposite action will take place, the regulator field-magnet decreasing in strength, the counter electro-motive force of its armature diminishing, and the current through it and the field-magnets of the dynamo increasing, thus restoring the strength of the main current. There is another piece of apparatus included in the regulator, and shown at the back of

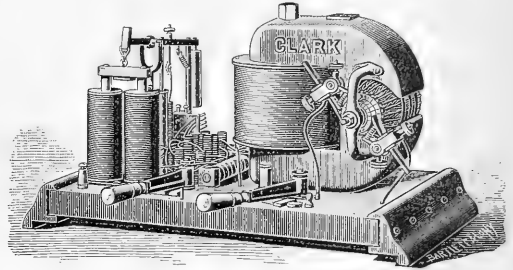

CLARK ELECTRIC COMPANY'S AUTOMATIC REGULATOR.

ing through the field-magnet coils. This, of course, causes a further reduction of the magnetism of the regulator field-magnets, the reverse action taking place when the current rises. It will be seen by this description that the regulating power depends upon the disturbance which is to be corrected; and the greater the disturbance, the greater is the regulating power; and, as it is not necessary that anything should move, the regulating influence can be exercised to a great extent instantaneously, while the entire power of the regulator can be exerted in the fraction of a second that is required for the lever of the solenoid armature to move.

It is stated that the 30-light regulator exerts a counter electro-motive force under extreme variations of the main current, ranging from three or four volts to seven hundred volts, which is enough to control the dynamo under the most violent changes of load; and, as there is no train of gears nor ratchet movements to be put in

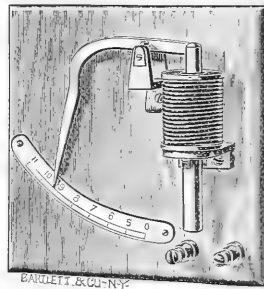

CLARK ELECTRIC COMPANY'S AMMETER.

motion, the regulation is accomplished in much less time than with any other device in use. The simple form of ammeter shown is supplied with each plant.

The arc-lamps shown in the illustrations are storm-proof, and do not require any hoods or other devices to protect them. The binding-posts are on the under side of the case, and will not become short-circuited by sleet or snow. The switch is also on the under side of the case, where it can be seen by the person operating it. These lamps have been exposed to the worst storms of the past winter; and, although at times completely covered with ice and snow, they have never failed to start when the current was turned on. The movement is claimed to be the most powerful ever put into a lamp. The moving parts are heavy in proportion, the carbon-holding rod alone weighing sixteen ounces.

THE WARD RAM FOR WAR-SHIPS.

IN a recent article on "Naval Wars of the Future," Admiral Porter, who is doubtless our highest authority on such matters, says, "Then there is the ram with which most of the sea-fights of the ancient Greeks were won. All foreign navies have vessels fitted as rams, which are expected to perform great service in

in 1878, by bad management, struck the 'Grosser Kurfurst' in the side and under water. The latter ship was sunk, and the former so damaged that she had great difficulty in getting into port."

In a similar irreverent way he says, "Neither fleet has what may properly be called 'rams;' both trust to the underwater 'snout,' which caused the sinking of the 'Grosser Kurfurst' and the disabling of the 'König Wilhelm.'" He also puts in the mouth of a

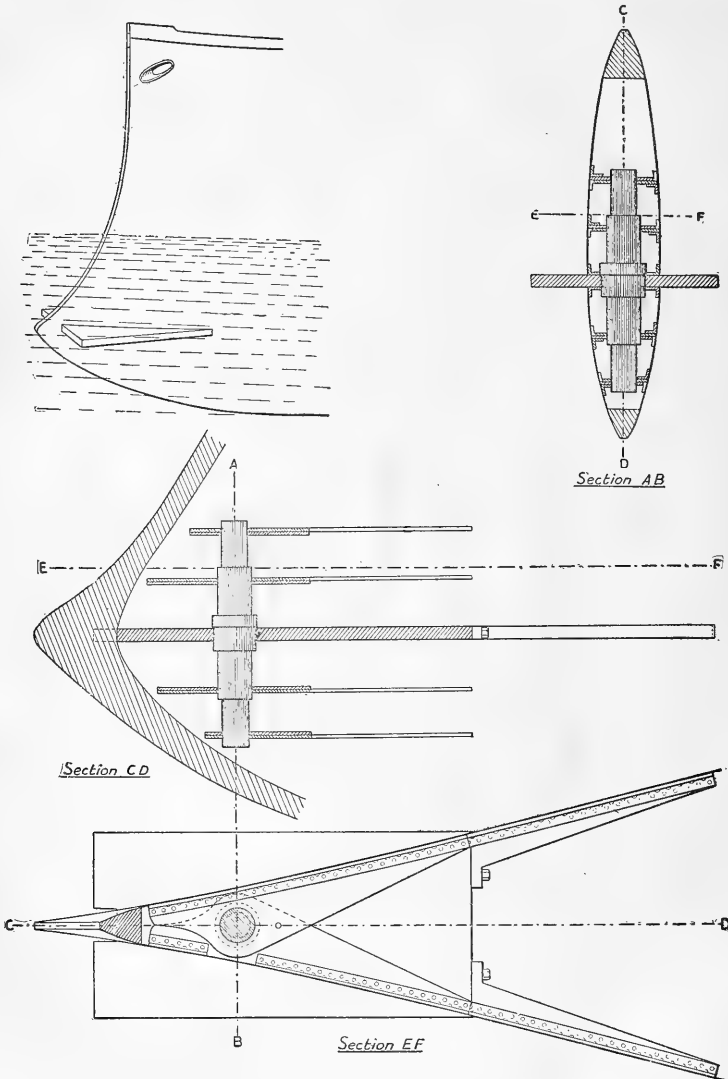

THE WARD RAM FOR WAR-SHIPS.

time of war. The 'ram' is simply an elongation of the bow under water; and although, no doubt, a vessel so fitted would inflict great injury on an enemy by running into her, she would be liable to injure herself quite as much, and go to the bottom with her foe. No modern rams have been tried in war, and ships so constructed will most likely be failures. In proof of this, take the case of the armor-clad frigate 'König Wilhelm,' of the German Navy, which

supposed English naval officer the saying, "Why have not the admiralty built proper rams, for those are the largest kind of projectiles?"

This description of a "proper ram" is certainly correct, for the blow given by a ship weighing, say, five thousand tons, moving at even as slow a rate as twelve miles per hour, would have many times the force of the heaviest projectile from the largest ordnance

ever constructed. The method of utilizing this force for the destruction of an enemy's ship, by vessels as now built, is to seize the opportunity when the intended victim is aground, at anchor, or in some way not in motion, and then to strike her as nearly at right angles to the exposed side as possible. This, of course, causes the complete stoppage of the attacking vessel, after which the engines are to be reversed, and the ram released. If the blow is given at an acute angle, or the attacked vessel is in rapid motion across the line of attack, the wrenching force produced would be perhaps more dangerous to the giver than to the receiver, owing to the lack of lateral strength in the form of ram as now universally built.

The consequence of this well-known lateral weakness of the regulation ram is, that all naval officers share Admiral Porter's opinion that no ship has yet been constructed that would serve the purpose of a ram; and they recognize the fact that the cases are few and far between in which a commander would be justified in risking his ship and his reputation in what he would himself feel to be a most reckless form of attack.

In view of this well-known idea, it seems strange that the form of ram shown in our illustration has not long ere this forced itself into use, as the thing, when once seen, looks too obvious and simple not to have come forward to fill the acknowledged want.

With a ram formed as this one is, the most advantageous angle of attack is precisely that which would be the most dangerous with the usual pattern, or, say, about twelve degrees. Every sailor knows how handily he can lay his ship alongside of a wharf or another vessel in such a manner as to foul his anchor when it is hanging at the bow, and this is the manœuvre by which he can use this ram with the best effect. The corner of the heavy iron plate will, as it touches the enemy's side, enter it with ease as far as the projection from the side of the bow will allow, and will cut a long furrow, plough-like, under the water-line. This attack does not necessitate any stoppage of the ship which acts on the offensive, as is the case where the blow is given "end on," which is an advantage of great moment in a strong current, a narrow passage, or when crowded by hostile or friendly vessels.

Having delivered her blow in passing, she is at once on her course again, and ready for whatever is required by the exigencies of the engagement.

The ram here illustrated, for use on war-vessels, is the invention of Mr. John F. Ward, M. Am. Soc. C. E., of Jersey City, N. J. Ships' rams, as usually constructed, present a sharp vertical cutting edge with comparatively little horizontal width. Such a ram, by striking squarely the side of an enemy's ship, may doubtless inflict much damage; but there is also great danger of wrenching off the ram of the attacking ship, by reason of a glancing blow or the swinging action of a strong current, or of so straining the frame of the attacking vessel that the ram would be practically valueless for further service.

The present device is intended to overcome the inherent disadvantages of the older form, and it accomplishes this end by a departure from former practice as radical as it is simple. Instead of a vertical plane of attack, we have here a horizontal ram, with projecting ends extending transversely through the bows of the war-ship, and presenting on either side of the stem an attacking angle of strong and heavy iron plate, so located as to strike below the water-line, and to be effective at almost any angle of approach. The most dangerous blow of all to an enemy with this ram would probably be an almost parallel glancing attack, which would tear a long, narrow path through the plating of the enemy's ship, and rupture any frame in the track of the ram. A hole of this nature would be most difficult to stop, and would to a considerable extent cancel the advantages of water-tight compartments in a war-vessel.

The drawings show the ram as arranged in the bow of the ship, though of course this arrangement might be modified at the will of the naval constructor, and in accordance with the type of vessel upon which it is to be used. The plate as shown here is about 6 inches thick, and about 8 feet wide and 16 feet long. Through the forward half of this plate passes a steel shaft about 24 inches in diameter, which is further braced 2 feet and 4 feet above and below the main plate by other stiffening plates, about 1½ inches thick, strongly secured to the sides of the ship by angle-iron; and

the main plate is also in like manner connected with the ship's sides. The purpose of this steel shaft and the supplementary plates is to transmit the strains coming upon the angle of attack of the main plate to as great a surface as possible in the bow of the ship. In the plan shown, this surface distribution amounts to about 269 square feet.

The plan or "Section E F" is proposed for the adaptation of this ram to a war-ship already built, in which the difficulty of adjusting a large single plate to the position required for the shaft is overcome by making the plate in pairs. This plan also shows heavy bars or brackets in the rear of the ram-plate, for further connecting it with the ship's side, and transmitting strain from the ram to the ship.

SANITARY CEILINGS AND WALLS.¹

MUCH has been done by the sanitarians of the country, and especially the Board of Health of this State, to try to enlighten the people sufficiently in regard to the unsanitary nature of the prevailing modes of coating, or recoating and ornamenting, the ceilings and walls of rooms for domestic habitation; yet much remains to be done in this direction. The reason is, no doubt, that those who strongly condemned the prevailing modes offered no relief, gave no way of any kind by which the people could even plainly cover their ceilings and walls. Professor R. C. Kedzie, in his lectures when president of the State Board of Health some years ago, advised his audience to forego the pleasure of decorated walls, or to simply whitewash them with lime, rather than stop what he terms "wall-respiration" by sealing or strangling the pores in the plaster with paste and paper, kalsomine, or paint. He illustrated to his audience, by means of blowpipes filled with dried mortar, and some coated with paper, others with paint and kalsomine, how readily air passes through walls of ordinary mortar and with stucco finish (the so-called hard finish), or when simply whitewashed, and how this "wall-respiration" was prevented by all the other modes; and under the professor's directions the State published a book entitled "Shadows from the Walls of Death," and placed copies of it in all the public libraries, with this Bible inscription on its cover: "And behold if the plague be in the walls of the house with hollow streaks, greenish or reddish, then the priest shall go out of the house to the door of the house, and shut up the house seven days. . . . And he shall cause the house to be scraped within round about, and they shall pour out the dust that they scrape off without the city into an unclean place."

This book contains seventy-five specimens of arsenical wall-papers, all gathered from the paper-stores of Michigan, and gives authenticated cases of poisoning from many of these papers; and on all of them arsenic was found in the colors, not only green, but nearly all colors and tints, and some also in making the finish or lustre. A year or two ago the sanitarians of Massachusetts made quite an effort in this direction, introducing a bill in the Legislature to prohibit the sale of such paper; but the paper-men used their influence against it, sent representatives to the Legislature, who claimed or pretended to prove that there was no foundation to the claims made by the sanitarians, and the bill was defeated.

Now, while there are many cases where the people have suffered from arsenical wall-paper, I am fully satisfied from a thorough study of this subject of wall-coatings constantly for fifteen years, and quite a portion of the time applying the same, removing old papers and kalsomine, and from talking with sanitarians and scientists on the subject, that a greater amount of sickness is caused from other conditions of the walls, and conditions that generally prevail, and in nearly every house, than from the very dangerous arsenical wall-papers; and I believe in many of the cases cited, where it was proven that the patients had suffered in rooms coated with paper which proved on examination to contain arsenic, that other conditions connected with the same paper and walls contributed largely to the troubles.

Before going further, I wish to explain that I will show, before the completion of this paper, how people may decorate their rooms in a way that is approved of by the sanitarians who had before condemned every thing used for the purpose, except lime white-

¹ Abstract of a paper read by M. B. Church of Grand Rapids at a sanitary convention at Hastings, Mich., Dec. 4, 1888.

wash. By the method I shall give, and illustrate with specimens I have with me, I will show that walls can be ornamented with any degree of elaboration desired, or plain, and at much less expense than with any of the old modes. The article has been sold for some years, and I find it in use by most of the sanitarians I talk with on this subject.

We will now consider the prevailing modes a little further. It is well known that most houses are papered, and that care has been taken in most cases to choose dark papers with many figures, for the same reason that a workman prefers a colored shirt; and I think I do not overstate when I say that seven-eighths of the buildings papered are papered more than once, that is, that two or more layers have been pasted on, one upon another, and that a large portion of these, say one-half of them at least, have from six to a dozen layers on. It seems as though people should only need to be reminded of this nasty practice, saying nothing about its effect upon health, to induce them to at least remove the old coats of paper and paste, after they have become filled with filth, before applying new coats. It is not necessary for me to explain, what every person knows, that flour-paste will soon mould; that it is a ready absorbent of moisture and disease germs; also that paper is a very ready absorbent. They may not be aware, however, that the coloring and bronzes, which are pulverized metals, brasses, etc., are only temporarily held upon the face of the paper with animal matter (glue), that soon decays; and glue is the greatest absorbent of moisture, and the natural culture-ground for the germs. If these little pests get sufficient heat while there, they will flourish (and the rooms are sometimes very warm above the lines of the doors and windows, with a moderate fire); and where repeated coats of this paste, paper, and glue are applied, from which outdoor air with its purifying effects is excluded by the respirating pores being sealed or strangled, the danger is much greater. The glue soon rots sufficiently to allow the air or any friction to remove small particles to which these germs have attached themselves to float about the room unseen, until they lodge in the system of some unsuspecting victim, whose physical condition is such that they take effect; then they still have the little particles of fertilizer with them to help give them a start on their deadly mission.

Dr. Henry B. Baker, secretary of our State Board of Health, has shown us many different kinds of these little bacilli, some of which he had printed cuts of, taken from photographs. He explained how, by the aid of the latest improved microscopical instruments, it was possible to distinguish these pests one from the other,—those causing typhoid-fever from those causing consumption, etc.,—and explained how their growth can be watched, where they have been caught on bits of moistened glue; how they must come to a certain state of maturity before they are dangerous; and that they do not then take effect unless the lungs, or other parts of the body they strike, are in such a weakened or inflamed condition that nature cannot expel them.

The fact that these conditions do not always cause serious mischief; that some people do live in rooms the walls of which are in a very unsanitary condition, and probably filled with vermin, contagion, and filth, without apparent or immediate injury to them,—causes many to think that these claims made by the sanitarians are without foundation, or not of vital importance, while they probably suffer from these causes, more or less, which they attribute to having taken cold, or to having committed some impropriety in eating or overwork; and when they become very sick, they flee to another climate, if they are well-to-do, where they often recover, probably by getting in a room not in so bad a condition, and return home to have the old trouble return, and continue to breathe this slow death-dealing matter, to save the expense of removing the filth from the walls, or because they do not believe or have not heard the warning.

Another unsanitary practice is what is known as kalsomining, which is the covering of ceilings and walls with coats of inert powders and colors, temporarily fastened to the wall with the same kind of animal matter used in coating wall-papers. This glue coat also strangles the wall, but is not so bad as wall-paper, seldom contains as much poison, and does not admit of coating so many times without falling off, though there is more glue in it (and it rots sooner) to be set afloat. Another bad practice is the painting

of walls with oil-paint, composed of lead, zinc, and colors mixed with oils. This seals the pores of the walls more effectually than does the kalsomine or wall-paper, but remains longer before it decays sufficiently for small particles of the lead to be dislodged, though it always gives off a slight smell of paint, and when the room has been closed it always has a stuffy or stifled smell, something as do also all rooms covered with many layers of wall-paper. The painted walls can be washed; but, even if washed frequently, the fine cracks always found in walls will be washed full of filth and the germs of disease, if any, in the room.

The article or process I have referred to as being adapted to making a clean, cheap, and sanitary coat for walls, is composed mainly of sulphate of lime, known as gypsum or alabaster, which has been calcined by subjecting it to great heat in retorts, or boiled in large kettles until its water of crystallization is driven off, so that, when water is added to it again, it will again take up its original water of crystallization. This process is called "setting," and takes place naturally in about seven or eight minutes, reforming a stone much like the original stone in the quarry, but more porous. This rock in the natural state, as we grind it at Grand Rapids for use on farm-crops, contains from 35 to 40 per cent of sulphuric acid. The better grades of this rock, after calcining, are so manipulated in making this article for walls, which is known as alabastine, that this setting process is retarded for a number of hours, adapting the plastic, or liquid, to being spread upon walls with a brush in a very thin condition; so that fifty coats, as applied to walls from time to time, form a hard, porous shell not thicker than card-paper; and the coat is not of a glue or paste nature, the size and admixtures used to retard the setting having been absorbed by the base in taking up its water in setting. There is only one other article on the market that is claimed to produce the effects produced by alabastine, and that is called "anti-kalsomine and plastic." These articles are made in many shades, ready for the brush, by adding water. Many kalsomines are put up and sold in the same form, but are dependent on glue to hold them to the walls.

The late Richard A. Proctor explained, in one of his last contributions to the *Inter-Ocean*, how much moisture, in tons, would be thrown off by respiration from an audience of a certain size in a given number of hours. That this moisture is condensed mainly on the walls of the room, is easily seen by rubbing the finger on almost any painted wall, where the moisture does not penetrate readily, but is on the surface, as is often seen on windows. This is sometimes seen on paper and kalsomine; but they absorb moisture so quickly that it does not show on the surface, though they attract more than the paint. That this moisture carries contamination with it, is certain; also that it rots such materials. The paint, as explained before, is not quickly rotted, but oxidizes slowly, so that the effect from it is not so bad as from paper or kalsomine. That air passes through walls is proven by the dust-marks seen on plastered walls, or those that have been only whitewashed or alabastined, indicating the spaces between the lathing caused by the dust being filtered from the air more between the laths than on them.

It should be borne in mind that it is not claimed that the amount of air that will pass through walls the pores of which have not been strangled, cuts any considerable figure in furnishing air to the inmates of the room, but that this purifying of the ceilings and walls takes place by the constant passing of pure air through and through them, oxidizing, or practically burning, these little germs, as it is well known pure air will do. In one of Professor Kedzie's lectures, he cites experiments made by Professors Marker and Shultz, in which they prove that a difference of 20 degrees in temperature on either side of a wall of brick and mortar would cause 8 cubic feet of air to pass through each yard of such wall every hour.

I have some samples here of the sanitary coating I have referred to, applied on panels, showing sections of quite elaborate designs, as well as plain work. I will explain them. This panel I now show you is finished mainly in what is called relief-work. This corrugated work on the lower portion is done by applying the alabastine thick; then a coarse graining-comb was drawn through it in various shapes, before it set. The colors having been ground

in and chemically united, it forms a solid tint all the way through the mass; so that slight abrasions, like cutting it off with a knife, still show the same color. Half of this combing has been varnished, which you see produces a somewhat darker and a satin or leather like effect. This varnished work is washable, and is as easily cleaned as any varnish. The centre is simply bronze in the varnish. The upper portion, or decorated frieze, has less body on, and was made by dipping each corner of a wide brush in the two different tints, which easily produced the blended or soft shaded effect. The ribbon was put on with a thin coat of the material through a paper stencil, and the vine in the same way. The flowers were put on with oil-color. The other side has at the bottom what is called heavy stippling, and a slight representation of bas-relief, that is sunk below the surface. The frieze above is ornamented in what is called flat relief, to imitate solid or high relief. The blended grounds of the frieze have been stippled; that is, pounced with the ends of a brush or with a covered block, to give it a slightly roughened effect. These effects are admitted, even by paper-dealers, to be finer than it is possible to produce with the finest papers, and will make a blended tint or whitened wall, on which borders, leaves, etc., can be applied with stencils, and keep within bounds of the expense of papering.

Here we have a plain tinting on large sheets of paper with what is called a combination stencil border. The background of the border was put on with one paper stencil, and the other or main stencil was used over it. This plain tint has the same stencil border on with one tint, which can be done as easily and as cheaply as the cheapest wall-papering. Here we represent a wall blended from top to bottom in two shades. The manufacturers will show any painter so that he can do this blending easily, and usually with one coat. This and the relief-work is done with a late make of this material, made for this kind of work. When it is necessary to renew alabastine, you have no old paper or kalsomine to take off, but simply to repeat the process. I should add, it will be seen, as this forms a stone cement that hardens with age, it precludes any possibility of the colors being liberated to float around the room, as they do from paper and kalsomine, even if they were poisonous. Some claim that a wall should be impervious instead of porous. This might do very well with perfect ventilation, if it were possible to have such a wall; but one partially so is only strangled, and gives a better chance for matter behind to ferment and the germs to propagate. Now, we show here sections of this work varnished, which is nearer impervious than any wall I have ever seen, as the varnish combines with the outer part of the porous stone surface by penetrating into it; also there is nothing behind but the pure stone cement of a cold nature, the air has access to the back of the varnish, and there is absolutely no chance behind for fermentation or decay. However, for plain work, it is as well, and as cheap in the end, without varnish (as it will stand some cleaning, with care, to remove spots); and the surface can be recoated almost as cheaply as the wall can be washed. Then you have a choice of new tints; and any broken places in the plaster, which always occur, are filled and cemented by brushing on this cement again with a brush.

NOTES AND NEWS.

THE senior class this year at Harvard numbers 210, and is the smallest class in the university.

—It looks as though California would have the largest crop of grapes in the history of the State. Manager Clarence Wetmore of the Viticultural Commission says, "There are some localities where, from present appearances, the Zinfandel will not yield as heavy as last year. White grapes in most localities are settling for a full crop, and, if nothing unfavorable happens from now till vintage time, we ought to produce from 20,000,000 to 35,000,000 gallons of wine. The raisin-crop will be a heavy one, even with the loss of several thousand acres of vines in Los Angeles County by disease. The State will probably produce 1,000,000 boxes. The outlook for the wine-market is not very good. At least half of the 1888 vintage is in the hands of producers, who will not sell at the ruling low prices. On this account there will not be sufficient coopeage to handle all the wine grapes that will be thrown on

the market. As a consequence, most varieties of wine grapes will bring low figures. There is great need of distilleries in this State to convert low-priced grapes into brandy, for which there is a steady demand."

—Below is the speech in which Professor Taylor of the University of Edinburgh proposed the name of Professor Whitney of Yale for the honorary degree of LL.D., which was conferred: "I have now to ask your lordship to confer the degree in absence on William Dwight Whitney, professor of Sanscrit and comparative philology in Yale College. After studying Sanscrit at Berlin and Tübingen for three years, Professor Whitney was appointed to the chair of Sanscrit and comparative philology in Yale College in 1854. In 1856, in conjunction with Professor Von Roth, he edited the Sanscrit text of the Atharva-Veda. During the last thirty years he has been one of the master spirits of the American Oriental Society, having been for several years its corresponding secretary, and latterly its president; and in the journal of that society he has published a translation of an astronomical work termed the "Surya Siddharta," the text and a translation of two Vedic grammatical works, an Index Verborum to the Atharva-Veda, and other important works. He is also the author of an excellent Sanscrit grammar, treating of the language in its historical development, and supplemented by an important catalogue of all genuine Sanscrit roots. Among his other works must be mentioned the "Language and the Study of Languages," the "Life and Growth of Language," the "Essentials of English Grammar," and his collected "Oriental and Linguistic Studies." Nor has he disdained less recondite subjects; for he has also published a German grammar and German reader, two admirable works of their kind. It is mainly to Professor Whitney's unwearying labors as a teacher and an author that America is indebted for the flourishing school of Oriental philology, in which he is *facile princeps*, and on those grounds he was invited to become one of our tercentenary honorary graduates. I have now the honor of requesting that the degree be conferred upon him in absence."

—At the Eiffel Tower, on May 29, Thomas E. Brown, jun., the engineer of Otis Brothers & Co., subjected the Otis lift to a final test before handing it over for public use. The lift, the car of which consists of two compartments, one above the other, weighs 11,000 kilos (24,000 pounds), and, loaded with 3,000 kilos (7,000 pounds) of lead,—that is to say, weighing 14,000 kilos (31,000 pounds),—was raised to a considerable height. There, according to *The Engineer*, it was fastened with ordinary ropes, and, this done, it was detached from the cables of steel wire with which it is worked. What was to be done was to cut the ropes, and allow the lift to fall, so as to ascertain whether, if the steel cables were to give way, the brakes would work properly and support the lift. Two carpenters, armed with great hatchets, had ascended to the lift, and were ready to cut the cables. At a given signal a blow cut the rope. The enormous machine began to fall. Every one was startled; but in its downward course the lift began to move more slowly, it swayed for a moment from left to right, stuck on the brake, and stopped. There was a general cheering. Not a pane of glass in the lift had been broken or cracked, and the car stopped without shock at a height of ten metres (33 feet) above the ground.

—In the Pearson process of manufacturing aluminium, as stated in the *Journal of the Society of Chemical Industry*, one hundred parts by weight of cryolite are mixed with fifty parts of bauxite, kaolin, or aluminium hydrate, fifty parts of calcium chloride, oxide, or carbonate, and fifty parts of coke or anthracite, all being in powder. The resulting mass is heated to incipient fusion in a furnace or in a crucible made of, containing, or lined with, carbon, in which case, the carbon may be omitted from the mixture. The heating is continued for two hours, at the end of which time it is alleged that the aluminium is reduced, and exists disseminated in minute globules throughout the mass. A mixture of twenty-five parts each of potassium and sodium chlorides is then added, and the temperature raised to bright redness: the aluminium collects at the bottom of the crucible. A better separation is, however, effected by powdering, washing, and drying the melt, and adding it to fused zinc, which alloys with the aluminium, and can afterwards

be removed by distillation. If copper be used instead of zinc in this process, aluminium bronze is obtained. Other fluxes than those mentioned may be employed.

— A submarine bridge is proposed between Sweden and Copenhagen by a Swedish engineer, Mr. Rudolph Littlejeqrist. The distance, according to *The Engineering and Mining Journal*, is two and a half miles, and the proposed structure would join Elsinore to Helsingborg by a bridge made up of one hundred feet spans, carrying a single line of rails. It is to be submerged sufficiently to allow ships to pass over it. The bridge would be incased in a double tube, with an outer skin of iron and an inner one of steel, and the space between the shells filled with concrete. It is foreseen that the outer shell might rust away in time; but it is believed that the concrete would remain intact, and protect the steel. The piers would be ordinary caissons, filled with concrete, and placed one hundred feet apart. The tubes would rest on these piers, and the girders would take a bearing on blocks inside the tube immediately over the piers. The tube would be floated out in one hundred feet lengths and lowered to place, and a massive collar of concrete put over the joints. Pontoons, with legs at each corner, worked by hydraulic rams, so as to give a stable platform, would be used in sinking the tubes. The estimated cost of the submerged work is about \$3,500,000, not including the approaches.

— According to the *Moniteur de la Céramique et de la Verrerie*, a method of electroplating glass and porcelain has been devised by M. Hansen. The chief difficulty hitherto experienced has been to obtain a conducting surface which would not prevent the proper adherence of the metallic coating. M. Hansen uses chloride of gold or of platinum dissolved in sulphuric ether, to which sulphur dissolved in some heavy oil is added. This compound, after having been slightly heated, possesses sufficient consistency to allow of a film being laid on the glass with a brush. The object treated in this way is then moderately heated in a muffle until the sulphur and chlorine are completely volatilized, the gold or platinum adhering firmly to the surface. The best copper bath is two parts of sulphate of copper to three of distilled water. In silver-plating, seventeen parts of nitrate of silver and thirteen parts of cyanide of potassium, dissolved in three hundred parts of water, are used. For gold-plating, seven parts of gold are used, which are preferably dissolved in *aqua regia*, and precipitated by means of ammonia. This precipitate, while still wet, is then placed in a warm solution, consisting of nine parts of cyanide of potassium and ninety parts of water.

— We recently published an extract from *Engineering*, descriptive of the use of the water-jet in sinking the wooden piles used in the construction of the Calais harbor-works, in which the remark was made, "We believe [the water-jet] had never been previously used in this particular manner." In response to this, Mr. L. Y. Schermerhorn, in a letter to *The Engineering and Building Record*, says that in 1881 he compiled a paper giving, as far as known, the history of the water-jet as an aid in engineering construction, which was published by the Engineering Department of the United States Army. From this paper it is clearly established that the use of the water-jet in sinking both wooden bearing and sheet piles had been applied in this country long previous to 1877, the date of its use at Calais. In 1852, Lieut. George B. McClellan used the water-jet for sinking piles in the government wharf at Decrows Point, Matagorda Bay, Texas. In 1854, Lieut. W. H. Stevens made a similar use of the water-jet in sinking sheet and bearing piles in the construction of a jetty for the protection of Fort Livingston, La., and for the foundations for lighthouses in the vicinity. In 1862, Mr. J. W. Glenn placed five thousand wooden piles across the channel to Mobile harbor, to prevent the entrance of the Federal fleet, by pumping them down with a water-jet. In 1867-69, O. Chanute, chief engineer of the Kansas City Bridge, used the water-jet for sinking bearing piles. In 1868, T. J. Whitman, chief engineer of the St. Louis water-works, applied the water-jet for sinking sheet piles for the coffer-dam about the foundation of the engines. In 1872, Major P. C. Hains used the water-jet in sinking piles for lighthouse foundations. In 1873, C. C. Martin, superintending engineer New York and Brooklyn Bridge, sunk sheet piles by aid of the water-jet. From the foregoing, it is evident that the water-

jet had been used in this country by engineers for sinking bearing and sheet piles nearly a quarter of a century previous to its use at Calais.

— According to the *Japan Weekly Mail*, an earthquake of a most unusual character was recorded at 2h. 7m. 41s. P.M., on Thursday, April 18, in the Seismological Observatory of the Imperial University, Tokio. The peculiarity lies, not in its violence, but in the extreme slowness of its oscillations. The beginning of the shock had all the characteristics of the ordinary earthquake; but gradually the motion augmented, until at a certain stage of the shock it reached seventeen millimetres, but the ground swayed so gently that the house did not vibrate visibly, nor were the senses alive to it. It took from four to seven seconds to complete one oscillation, — a most unusual phenomenon, and one never before noted in the observatory. The motion was almost entirely confined to the horizontal plane, and mostly south to north, but there were a few vertical motions of equally slow periods. This state of things lasted for ten minutes thirty-six seconds. Professor West of the Engineering College observed the water in a small pond to oscillate gently from north to south. At one time the water-level fell about two inches on one side of the pond, and exposed the bank, while a few seconds later the water immersed it nearly to the same depth, exposing the opposite bank; and this process continued for a quarter of an hour. "Slow oscillations of this nature have been called 'earth-pulsations,' and these usually take place where there is a destructive earthquake or a submarine disturbance going on at a great distance. Earth-pulsations are known to have caused slow oscillations of the water in lakes. From this fact it may not be unreasonable to conjecture that a terrestrial or submarine agitation of unusual magnitude has taken place somewhere. The authorities of the Science College have sent to the Hydrographical Bureau of the Naval Department, asking for information as to the state of the tide and seas. It may be as well to remark that it is not certain whether the maximum motion of seventeen millimetres, as given by the seismograph, is perfectly accurate, as it is very difficult to measure slow oscillation like this with absolute certainty." It is now known as a fact that Vries Island, outside Yokohama Bay, and possibly sixty miles off, was in a state of violent volcanic eruption.

— Naphtha is now much used as fuel in middle Russia. Last year, 880,000 tons of it were sent up the Volga for fuel purposes; and it is expected that the export for the same purpose will this year reach no less than one million tons.

— The province of St. Petersburg is very rich in marshes covered with a thick carpet of vegetation, which conceals water to the depth of several feet, — sometimes twenty-five feet and more. Small lakes and branches of rivers are continually being transformed into such marshes; and M. Tanfilieff, who has studied the way in which the transformation goes on, comes to the following conclusions (*Mémoires of the St. Petersburg Society of Naturalists*, vol. xix.), which are given in *Nature*: "The pioneers of the transformation of a lake into a marsh invariably are flowering plants, such as *Menyanthes*, *Comarum*, *Cicuta*, *Equisetum*, *Carices*, and the like. Their roots and underground stems make a thickly woven floating carpet, which soon totally conceals the water. The *Sphagnum* invades this floating carpet, while the water beneath becomes filled with *débris* of decaying plants, transformed later on into peat-bog. In shallow basins the transformation goes on at a much speedier rate, as their bottoms are invaded by plants, like *Phragmites* and *Scirpus lacustris*, which reach a considerable height, and thus supply, after their decay, a good deal of additional material for the filling-up of the basin. A mass of smaller plants, such as *Lemma*, *Hydrocharis*, *Callitriche*, *Utricularia*, *Hypnum fluitans*, and several others, usually grow also amidst the rushes. Of course, the streamlets which flow into the basin contribute also to fill it up by bringing in sand and loam. As soon as the floating carpet has reached a certain thickness, and the *Sphagnum* has still more increased its bulk, various plants, such as *Drosera*, *Vaccinium*, *Eriophorum*, the dwarf birch, and other bushes, begin to grow upon it, although the space beneath still remains filled with water. As the *Sphagnum* does not grow upon ponds containing a chalky water, its place in such ponds is mostly taken by the

Hypnum; and in these cases a variety of other plants, such as *Typha*, *Stratiotes*, *Butomus*, *Ranunculus divaricatus*, and *Chara fragilis*, make their appearance. As to the *Sphagnum*, it invades wet meadows as well."

— Dr. F. Nansen, at a recent meeting of the Geographical Society of Copenhagen, delivered an interesting lecture, in which he sketched the scientific results of his Greenland expedition. The ice on the east coast, he said, is difficult to pass, because it is intersected by deep fissures. The opinion that the summits which emerge from the inland ice make travelling difficult, must be abandoned. On the contrary, they make the ice more level, and retard its motion. Future expeditions will have to take advantage of this fact. On the plateau the ice is similar to a shining sea. Its surface is covered with loose snow, which is kept in motion by a continuous wind. In the interior there is nothing but ice and snow. There is no point on which the eye can rest, and the traveller has to be guided by the compass, as on the open sea. The snow does not melt, and the snow-fall is very heavy, while there is no rain. It is impossible to cross the interior without the use of snow-shoes. Reindeer might be used, but the difficulty of carrying a sufficient amount of provisions would be enormous. Notwithstanding the low temperature and the heavy snow-falls, the thickness of the ice does not increase, as the glaciers carry enormous quantities into the sea, and as the heat of the interior of the earth is not without influence upon the ice-cap. The temperature of the inland ice increases with increasing depth, and at the point where it rests on the rocks it is undoubtedly melting. The cold on the plateau is intense: the breath of the travellers froze as it left their mouths. On the whole, Dr. Nansen said, the scientific results of the expedition may not have been as great as many had expected, but his expedition had shown that the ice is not impassable, and future journeys would give better results.

— Columbia College makes an announcement of the course in electrical engineering in the School of Mines department. The officers of instruction and government, besides Henry Drisler, LL.D., acting president of Columbia College, are, William P. Trowbridge, Ph.D., LL.D., professor of engineering; Francis B. Crocker, E.M., instructor in electrical engineering; Michael Pupin, A.B., assistant teacher in electrical engineering; and George F. Fisher, registrar. This course in electrical engineering has been established in the School of Mines, open to graduates of that school and of other institutions of like grade and standing. The full course will occupy two years: there is a partial course which can be completed in one year. The course of instruction will comprise: 1. General principles of electricity; 2. Principal phenomena of electricity; 3. Simple applications of electricity; 4. Theory of the dynamo and motor, dynamo and motor regulation, transmission and distribution of power, electric-railway systems and locomotives, telegraph systems (duplex, multiplex, printing, autographic, and submarine), telephone systems, electro-chemistry (including theory of primary and secondary batteries), electro-metallurgy (plating, reduction, separation of metals), electricity applied to mining, torpedoes (stationary and movable). In addition to the lectures and study of standard electrical text-books, there will be examinations and explanations of practical electrical machines and models; examinations and reports of visits to electrical stations, factories, and plants; workshop practice in actual construction of electrical apparatus and machines; designing and drawing of electrical machines and apparatus for construction; design, drawing, and preparing specifications for electrical plants; practical work in setting up and use of instruments for testing; a study of the mathematical relations of electricity, light, heat, magnetism, and mechanical energy; the mathematical determination of electrical laws, units, and constants; and the mathematical theory of flow and action of intermittent and alternating currents. Graduates of the School of Mines, and of other institutions of like grade and standing, will be admitted to the course without examination; but, in cases where there may be any doubt of the proficiency of such graduates, they may be required to pass such examinations as shall be prescribed by the faculty. For particulars as to the course of instruction, etc., in electrical engineering, apply to Professor W. P. Trowbridge, and for general information and circulars, to George F. Fisher, both at

the School of Mines, Columbia College, 49th Street, corner Fourth Avenue, New York.

— This year, according to the *Botanical Gazette*, is the centennial of the introduction of the chrysanthemum into Europe, and of the dahlia into England.

— In a communication to the North London Photographic Society, Mr. J. Jackson stated that he had succeeded in developing gelatino-bromide paper in a dark-room lighted by a gas-jet whose only protection was a globe of ground-glass covered with a thin sheet of yellow paper. Although we should not advise a repetition of this experiment, we desire to call the attention of our readers to it, because it is instructive in showing how unnecessary it is to try the eyes with deep ruby-colored light in the developing-room. It is in this point — namely, the practicability of safely using yellow rather than red light — that the statement of Mr. Jackson is valuable. He claims that his success was largely due to the amount of actinic light kept back by the ground-glass. This is also quite true; and the estimate has been made that ground-glass absorbs fully one-tenth of the light passing through it. The use of yellow light in the developing-room, when properly managed, is not only safe, but actually better than red light. The sensitive-film need not be exposed to the yellow light for any long time, and, if necessary, the developing-pan may be covered with some opaque substance.

— The question is sometimes asked, "What forms of vessel are best for washing paper prints, and of what material is it advisable to make them?" For amateurs who work on a small scale, and who can give constant attention to their prints, an ordinary deep porcelain tray of large size is as good as any thing. The water may be admitted through a rubber tube long enough to curl on the bottom, and thus give a circular impulse to the flow of water and at the same time keep the prints from sinking to the bottom. A stout glass rod (or, better, a slip cut from a long piece of glass) is laid across each corner of the tray, so that when the prints are floated upward they may not escape. Neither iron nor tin should ever be used. Zinc, however, may be made to serve a useful purpose for the final washings of silver prints, if a good coating of some waterproof varnish be first applied. Black asphaltum or heavy shellac repeatedly laid on would answer. Wood is a safe material so far as any effect upon the prints is concerned. It should be well dried before being made up, and plenty of pure paraffine melted into its pores by means of a hot flat-iron. The only trouble with these wooden trays is that they generally split apart or open at the seams if laid away out of use for a time.

— Madison University, Hamilton, N.Y., will be known, as soon as legal preliminaries can be effected, as Colgate University. The change found many advocates, and naturally some opponents; but at a joint session of the boards of the university and executive society a free and satisfactory discussion of the reasons for the change showed a vast preponderance of opinion in favor of it. The move for selecting the name "Colgate" is to recognize the eminent services of the Colgate family of New York of the generations past and present, in behalf of the university and its interests. The reasons for dropping "Madison" are the many serious and annoying mistakes made by confounding the New York institution with the University of Wisconsin at Madison, frequently spoken of as "Madison University."

— Among recent deaths of English scientific men reported in *Nature*, we note that of Mr. John Frederick La Trobe Bateman, F.R.S., who died at Moor Park, Farnham, at the age of seventy-nine, after a severe illness (Mr. Bateman was well known as the engineer who supplied Glasgow with water from Loch Katrine); of Eugen Ferdinand von Homeyer, the eminent ornithologist, who was born at Herdin, near Anklam, in 1809, and died at Stolp, in Prussia, on June 1 (he had been president of the Ornithological Society at Berlin, was the author of several works, and possessed the largest existing collection of European birds); of Dr. Bernhard Weissenborn, the zoologist to the German Kamerun Expedition, from a fever contracted through the hardships of the work and the bad climate; and of Dr. C. Jessen, the naturalist, formerly professor at Greifswald, and lately at the Berlin University.

SCIENCE:

A WEEKLY NEWSPAPER OF ALL THE ARTS AND SCIENCES.

PUBLISHED BY

N. D. C. HODGES,

47 LAFAYETTE PLACE, NEW YORK.

Subscriptions.—United States and Canada.....\$3.50 a year.
Great Britain and Europe..... 4.50 a year.
Science Club-rates for the United States and Canada (in one remittance):

1	subscription 1 year.....	\$ 3.50
2	" " 1 year.....	6.00
3	" " 1 year.....	8.00
4	" " 1 year.....	10.00

Communications will be welcomed from any quarter. Rejected manuscripts will be returned to the authors only when the requisite amount of postage accompanies the manuscript. Whatever is intended for insertion must be authenticated by the name and address of the writer; not necessarily for publication, but as a guaranty of good faith. We do not hold ourselves responsible for any view or opinions expressed in the communications of our correspondents.

VOL. XIII. NEW YORK, JUNE 28, 1889. No. 334.

CONTENTS:

A GOOD RECORD FROM ATLANTIC CITY.....	493	ETHNOLOGY.	
THE CLARK ELECTRIC COMPANY'S APPARATUS.....	494	Marriage Ceremonies of the Bilqula 505	
THE WARD RAM FOR WAR-SHIPS.....	496	HEALTH MATTERS.	
SANITARY CEILINGS AND WALLS.....	497	American Public Health Association 505	
NOTES AND NEWS.....	499	Ice-Water.....	506
EDITORIAL.....	502	The Mortality among Nurses.....	506
River-Pollution in Connecticut.....		Underground Water and Bacteria..	506
DR. H. MEYER ON STANLEY'S EXPEDITION.....	502	The Fly as a Disease-Carrier.....	506
THE LAKES OF THE SAN JOAQUIN VALLEY.....	503	BOOK-REVIEWS.	
THE CAMERA ABROAD.....		Principles of the History of Language.....	506
Ellerslie Wallace 504		Seraphita.....	507
PREPARATION AND PROPERTIES OF MANGANESE.....	504	La Société Française au Dix-septième Siècle.....	507
		AMONG THE PUBLISHERS.....	507

TWO YEARS AGO the Connecticut Legislature very commendably appropriated five thousand dollars for the investigation of the pollution of streams, intrusting the work to the State Board of Health. The results of the investigations, carried on by Dr. S. W. Williston, have shown the rapid and alarming increase of river-contamination, a half-dozen of the rivers already being very greatly or excessively polluted. The Naugatuck, for instance, — a stream upon which are situated many of the large metal-manufactories of the State, and with a summer-weather flow of about ten million cubic feet at its mouth, — receives not less than twenty-five hundred tons of manufactory refuse annually, in addition to the sewage of about seventeen thousand people. At the last session of the Legislature a like appropriation was intrusted to the Board of Health for the investigation of the potable waters of the State, which investigation will be carried on, under the direction of the secretary, Dr. C. A. Lindsley, by Drs. H. E. Smith, T. G. Lee, and S. W. Williston, of the Medical Department of Yale University, and will include the monthly examination of potable waters, chemically, bacteriologically, and microscopically, on essentially the same plan as that so extensively and thoroughly pursued by Professors Drown and Sedgwick for the Massachusetts Board of Health. The results of the investigations cannot help but be valuable, as hitherto scarcely any attention has been given to the subject in the State, and many of the waters used for domestic purposes are at times confessedly bad.

DR. H. MEYER ON STANLEY'S EXPEDITION.

DR. H. MEYER, at a recent meeting of the Berlin Geographical Society, delivered an interesting lecture on Stanley's expedition. We learn from this experienced traveller that the region traversed by Stanley was, up to this date, totally unknown. From his letter the general outlines of its topography have become known. The upper course of the Aruvimi is not the Nepoko, as Junker was inclined to think, but its source is in the Speke Mountains, north-west of Lake Albert Nyanza, in which the source of the Welle-Obangi is also situated. The length of the river is approximately 1,000 miles. Whether the Muta Nzige belongs to its system or not, is doubtful. Stanley assumes that the latter belongs to the Kongo basin, as the southern affluent of the Albert Nyanza, the Semliki or Kakibi, is said not to come from the Muta Nzige, but to rise in the mountains of Ruwenzori, which were discovered by Stanley, and are described as a high snow-covered mountain about fifty miles south of Lake Albert. It may be that it is the same as the Gambaragara Mountains. If Stanley's observations, according to which the level of the Muta Nzige is lower than that of the Victoria Nyanza, be correct, it cannot belong to the system of that lake.

From the Kongo to the Albert Nyanza the country rises gradually, and attains an altitude of 5,200 feet close to the lake. There is a sudden fall to the lake, which is 2,900 feet high; and the high range of mountains which is seen on the west side of the lake is nothing else than the eastern slope of this plateau. Stanley found the level of the Albert Nyanza considerably lower than at his first visit, and expresses his opinion that this fact is a consequence of the rapid erosion of the Nile at Wadelai, and the deepening of the outlet of the lake. It is more probable that this lowering of the lake-level is due to a change of climate, as all the lakes of Central Africa show the same phenomenon.

Stanley describes the whole region between the Kongo and the Albert Nyanza as covered with an enormous forest 250,000 square miles in extent. This does not appear probable, as Stanley travelled most of the time close to a great river, and met with open country as soon as he left its course. On his former journeys he has also concluded erroneously, from the appearance of the banks of the Kongo, that the whole region is covered with dense forests, while it is to a great extent open land.

A description of the vegetation of this country from so excellent an observer as Dr. Junker, who reached the Nepoko coming from the north in 1882, is of interest. He says, "Close to the river, on the walls of its deep valley, and frequently beyond the upper edge of the latter, dense forests are found. Scarcely a ray of the sun penetrates these dark masses of trees. The woods are sometimes as wide as one or two miles. As every small river has a rim of such forests, and the land is drained by a great number of brooks and rivers, these forests, notwithstanding their narrowness, resemble the extensive tropical woods of South America."

If we compare this description with Livingstone's, Grenfell's, Delcommune's, Wissmann's, and other reports on the forests of Central Africa, we will be safe in assuming, instead of Stanley's 250,000 square miles of forest, about 25,000 square miles.

The tribes inhabiting the region between the Kongo and Nepoko construct conical huts. East of the Nepoko, Stanley found the Mabode, who build square houses, and who were first described by Junker. Farther east he met one hundred and fifty villages of dwarfs, who are called Wambutti. He compares them to the Tikki Tikki or Akka, who live a little farther north. Junker met them among the Mabode on the Nepoko. They were called Achooa.

Stanley's reports regarding the state of affairs in Emin's province are very meagre. He confirms Emin's former report, that there are fourteen stations which are garrisoned by two battalions of regulars, who have 1,390 guns. Besides the regulars, Emin has irregular soldiers, sailors, tradesmen, merchants, and servants, — about 8,000 all told. Besides these, there are 10,000 women and children.

Evidently it is not the object of Stanley to take Emin home from his province; but, on the contrary, he intends to enable him to hold his own, and to enlarge his influence, by supplying him with

ammunition and provisions. Emin Pacha is an Egyptian officer, and Stanley travels as well for the Egyptian Government (which is almost an English government) as for the English Relief Committee, the president and secretary of which are Mackinnon and Mackenzie, who are also directors of the English East African Company. This fact is very significant.

Undoubtedly Stanley's silence regarding his interview with Emin Pacha is due to the fact that this interview was of a political character, and that its subject is not yet to be made public. It is very remarkable that Stanley did not carry a single line from Emin. His object was to save Emin's province for Egypt, that is to gain it for England, and to forestall any other power which might contemplate occupying that territory. We believe that Stanley has succeeded in doing so. Emin continues to consider himself an Egyptian officer. As the Sudan continues to be closed, his next object will be to open communication with the east coast through English territory, and thus his further course becomes self-evident. Stanley states in his letter that he does not contemplate returning on the Kongo route. Mr. Stokes, agent of the missions at the Victoria Nyanza, informed Dr. Meyer that he had long ago sent hundreds of loads of goods and provisions for Stanley to Kavirondo, on the east side of the Victoria Nyanza. The second English relief expedition, which started from Mombas in November of last year through English territory, and which was greatly helped by the discoveries of Count Teleki, who returned at that time to Mombas from the interior, will probably have advanced sufficiently far to help Stanley in reaching the coast and protecting the expedition from any attacks of the Wagonda. The latest rumors of Stanley's march eastward are quite probable, and presumably he will reach the coast at Mombas. But it is improbable that Emin Pacha will accompany him. He will stay at his post for Egypt — and for England.

THE LAKES OF THE SAN JOAQUIN VALLEY.

THE rapid contraction by evaporation of the three lakes of the upper San Joaquin valley, the consequent concentration of their waters into alkaline lyes too strong for animal life, and the nature of the soils laid bare on their margins, have formed the subjects of investigation and discussion in several reports of the Agricultural Experiment Station of the University of California, especially in connection with the reclamation and cultivation of alkali soils. It is a matter of regret that it has not been possible to pursue the subject by personal visits as systematically as its practical importance and theoretical interest might have warranted; for we are here in presence of a group of phenomena that have been repeated many times in past geological epochs, and for the study of which, in their physical, chemical, and biological aspects, opportunity is not often afforded. Hence, while the information and data given in a bulletin issued by the experiment station June 15, are of necessity incomplete and fragmentary, they are of interest as affording an insight into processes regarding which but little is thus far on record.

A personal examination of Kern Lake, and of the region lying between it and Buena Vista Lake, as well as of the Mussel Slough country, made under the auspices of the United States census in March, 1880, satisfied Professor E. W. Hilgard that in none of these rich agricultural sections could the slightest increase of alkali be safely risked; and analyses subsequently made of the waters of both Kern and Tulare Lakes prove that a very few years' use of the water then filling either of these reservoirs would be promptly fatal to the productiveness of the lands irrigated. As regards Kern Lake, this was obvious enough from a casual examination and tasting of the water. Having been shut off from the natural influx of Kern River for a number of years, it has been rapidly evaporating and receding from its former shores, so that at the time of Professor Hilgard's visit a difference in level of over four feet had been produced in fifteen months, leaving high and dry a boat wharf built at that distance of time. About eighteen months before, all the fish and turtles in the lake had suddenly died, creating a pestilential atmosphere by their decay; and even the mussels were mostly dead, a few maintaining a feeble existence. A strong alkaline taste and soapy feeling of the water fully justified their choice of evils. The tule marsh, laid dry by the recession of the lake, was

thickly crusted with alkali; and the tules were dead, except where still moistened by the water of the lake, showing that the latter was not yet too strong for such hardy vegetable growth, albeit fatal to animal life.

Buena Vista Lake was stated to be in a similar condition, but not yet quite so far advanced in evaporation, and still maintaining some animal life in its waters, having lost its connection with the river more recently. Tulare Lake is well known to be full of fish, and, as it annually receives the overflow of Kern and the regular inflow of King's River, its evaporation and recession have been much slower; yet its water's edge is now distant several miles from the former shore-line, and, as the water of the river is more and more absorbed by irrigation, it will doubtless continue to recede until a point is reached at which the regular seepage from the irrigated lands will balance the evaporation.

A comparison of an analysis in 1888 with those made in 1880 shows that the solid contents of the water of Lake Tulare had increased very nearly two and a half times in eight years, and that its concentration approximated closely to that of Kern Lake in 1880. Yet it appears that an abundance of fish survived, at least of certain kinds, although the mussels had already succumbed.

Having been informed in November, 1888, that "the fish in Tulare Lake were dying by shoals," Mr. J. G. Woodbury of the State Fish Commission visited the north-eastern part of the lake, near the mouth of Cross Creek, during the first week in February.

On inquiry about the reported dying of the fish, the fishermen said that it occurred last summer and autumn, and that it was mostly catfish, "greasers," and some of the so-called trout, also some carp, but very few perch. Now, it is the perch that is so much valued by the fishermen; in fact, the perch is what they fish for, as the catfish do not sell so well, and the greasers are of no account. The "trout," they say, are very soft, and do not keep well, also are very insipid.

The perch are certainly very fine fish, large, bright, and clean-looking; they are also very good eating, as Mr. Woodbury had occasion to verify. These perch have enormous mouths, and in that of every one in the pound can be seen a "shiner" (or "slick," as they call the fish) with the tail sticking out of the great mouth, being drawn farther in as the process of digestion proceeds. One perch which he took along to have cooked, he took by the gills, and, looking down his big mouth, saw the tail of a fish, which he readily got hold of with his fingers and pulled out. It was six inches long, and only had its head partly digested. The fishermen say that all these perch, when caught, have fish in their mouths, in proof of which he pulled out one at random with a dip-net, and showed the perch with a shiner's tail still out of the mouth.

The fishermen state that no catfish are now caught, while two and three years ago they would get a wagon-load at each haul; also that trout are now seldom caught, although they used to be very abundant. The men expressed no opinion as to the cause of the death of the fish, but stated that the catfish especially were drifted upon the shore, dead, by thousands. Catfish, however, are found by millions at present in the creeks and sloughs that run into the lake.

All the shore of the lake for miles was strewn with mussel or clam shells. The surface of the ground was white with them, and the wheels of the carriage crushed through them, as though more than half the substance of the ground was actually made up of shells. These shells extend here as thickly as on top, down to the depth of a hundred feet. Not a live clam can be found in the lake now. Ten years ago there were large numbers of live mussels in Tulare Lake, and the hogs used to live on them. They would wade out into the lake, and plunge their heads under water, get hold of a mussel, and hold their noses up in the air and chew it up.

For the whole distance of twenty miles from Tulare City the country is of remarkable fertility, almost level; and, where put into wheat, the growth was strong even to within two miles of the shore of the lake. The lake must have been at some time a good deal lower than it is now, for near the mouth of Cross Creek there are many stumps which were under water only last year, and among which the fishermen used to get their nets entangled. These stumps are now just at the water's edge.

Analyses show an extremely rapid increase of the solid contents of the water between June, 1888, and February, 1889, as compared with the effect produced during the previous seven and a half years. The latter was about two and a half times or 150 per cent on the whole, or an average of 13 per cent a year; while in the eight months preceding the last examination the increase was nearly 45 per cent. It should be noted that these eight months were remarkable for very great evaporation elsewhere on the coast, also, and that they formed the end of three years of rather deficient rainfall in the State. The more abundant moisture of the season just passed may have stopped or perhaps even reversed the process.

It is hoped that all persons who may, from their own observation, be able to throw light upon the history of the recession of these lakes, will communicate the facts, so as to place them on record.

THE CAMERA ABROAD.

In a recent article in *The Swiss Cross*, when speaking of photographing in foreign countries, I advised every one to become familiar, to some extent at least, with the French language, and particularly with the technical terms used in photography; the different portions of the apparatus; the chemicals; short phrases to be used in the custom-house, to the police, to hotel servants, etc.

I need hardly say that those who intend to visit the German fatherland ought to pursue the same course with the German language. As a general rule, the traveller will find that English is spoken tolerably well almost everywhere; but it is when he goes out, and rambles about in the country or in the older and more picturesque portions of cities and towns, that he comes in contact with a class of persons who rarely speak any other tongue than their own. The mere presence of a stranger in such places will attract notice. Any thing like sketching, drawing, or photographing will be sure to draw a crowd of idlers, who will sometimes render work in these places very unpleasant, or even at times quite impracticable. A little knowledge of the native tongue is invaluable under such circumstances.

I have frequently been asked the question whether the lower orders of the people in different European countries acted differently toward the out-door photographer. On the whole, I think I can say that there is less annoyance in Germany than in most other countries. I must, however, make this reservation: that if a public school is dismissed while the photographer is anywhere near, there is sure to be trouble. The children crowd around the camera, and spoil every thing. On one occasion I was fairly driven from the field from this cause; for, even knowing the language, I found it impossible to keep them from encroaching. There is no ill nature, however, in this sort of interference with photographic work; but in some parts of the Netherlands I have had very disagreeable encounters with drunken roughs, who persisted in standing directly in front of the instrument, even when they saw plainly that they were hindering the work.

Supposing that the amateur starts for Germany on one of the comfortable Bremen or Hamburg steamers from New York: he will find himself pretty well in the fatherland from the moment when he sets foot on the vessel. The officers and crew are German to a man. The food is German, and so are the customs observed on the vessel. A very pretty one is the music which is generally furnished by the stewards during the dinner-hour every day, and early on Sunday mornings. At these times some piece of a solemn or religious character is always selected, and the effect made upon the mind by being thus awakened on a steamer in mid-ocean by religious music is not soon forgotten. The music at dinner, however, even on Sundays, is any thing but solemn in character; and the choruses to the well-known German convivial songs are joined in by all the passengers who can sing, and roared out right lustily, to the great satisfaction of those who, not being able to sing, contribute their part in screams of laughter and ringing applause. The good cheer at the table does not suffer neglect during all this babel of sounds, and, let me say in parenthesis, it is of unsurpassed quality. Americans are too apt to associate ideas of German cookery with sauerkraut and beer; but on these vessels such ar-

ticles are rather conspicuous by absence, and the table is furnished with every luxury that a pampered appetite could demand.

If the photographic apparatus is of small and convenient size, there will be numerous scenes and incidents on board a large ocean-steamer worthy of being recorded. The same apparatus could hardly be expected to answer for groups on the deck and for effective views of vessels passing. While steaming in the harbors of cities like New York, Hamburg, or Bremerhaven, capital instantaneous shots may be made at the water-craft of all kinds, but a lens of long enough focus to reach them nicely would probably be found unmanageable for groups of people on deck. If photography be attempted at sea while the vessel is rolling, take care to keep the camera level with the horizon, no matter what position the ship may assume. This, of course, is easier to say than to do; but, if neglected entirely, the pictures will make the level surface of the ocean appear like a steeply inclined plane. Remember that the forward part of the vessel is the most desirable standpoint for the camera, because the jarring motion of the screw is less felt here than in the after part. If the instantaneous shutter was a rather slow-working one, the outlines of the picture might be doubled by the vibration of the screw.

Those who are fond of making studies of clouds will here have an excellent opportunity. As a general rule, the best time to work is in the afternoon; and in selecting a position for the camera, take care that none of the ship's braces or shrouds cut across the field of the lens. This may happen at times when work has to be attempted in a hurry; as, for instance, when the pilot is taken on, when the tug comes for the mail, etc.

Great care must be taken not to expose the outfit, and particularly the sensitive plates or paper, to the damp sea-air for a longer time than is absolutely necessary. The sliding doors in the plate-holders should be constantly looked to, and special examinations made by red light at night to see that the spring cut-off in the slot of the holder closes properly when the door is withdrawn. A little time and trouble bestowed in this manner will be well rewarded by clean results, free from light-streaks and fog; for it will often happen that the cut-off swells just enough to leave a crack open when the door is pulled out, and the consequence is that every exposure is "light-struck." It is a good plan to take a sheet of fine sandpaper, a small screw-driver, and a sharp pocket-knife on all photographic excursions, so as to be prepared for accidents of the kind. The practice of throwing the focusing-cloth over the holder when the door is drawn out is a great protection to the film, and should always be done.

The port of Bremerhaven, where the amateur will probably land in Germany, offers little of interest; but just the reverse is true of Bremen, seventeen miles away. Of this I will speak in my next.

ELLERSLIE WALLACE, M.D.

PREPARATION AND PROPERTIES OF MANGANESE.¹

The properties of manganese, like those of iron, appear to differ according to the method used in the reduction of the metal. When obtained from the oxide by heating with carbon, most authorities agree in the statement that the metal oxidizes so readily in the air that it can be preserved only under "rock oil" or in well-sealed vessels. In water it is said to "oxidize rapidly, with evolution of hydrogen, and crumbles into a dark gray powder." Cast manganese containing eight per cent of iron is said to be unaltered in the air.

In the year 1869, some manganese prepared after the process of Brunner (the reduction of the chloride mixed with fluorspar, by means of sodium) was found to have as little tendency to oxidation as iron. Repeating recently this process, pure chloride of manganese was fused in a clay crucible, and poured on a stone slab. When cold, it was pulverized, and mixed with an equal weight of powdered fluorspar. This mixture, divided into portions of one ounce, was introduced into a French clay crucible, previously heated to redness. Eighty grains of sodium, cut into small pieces and freed from naphtha, being added to each portion, the crucible was covered, and re-action allowed to take place before adding an-

¹ Paper read at the meeting of the chemical section of the Franklin Institutes Philadelphia, May 21, by Charles Bullock.

other charge. After six ounces of the mixture had been added, the contents of the crucible was covered with fused chloride of sodium in powder, the cover replaced, and the heat carried to quiet fusion. After the flux became entirely fluid, the heat was continued for ten minutes. The crucible was then removed from the fire, and, after cooling, the metal was found as a button at the bottom.

Three crucibles, of the capacity of eight fluid ounces each, were used at a time in a furnace without artificial blast. Care is necessary not to urge the heat too high, otherwise the crucibles will not resist the action of the fluorspar flux. The French-lead crucibles (Beaufay) were used, on account of their greater freedom from iron and silica; they also resist the flux better than the Hessian, black lead, or iron crucibles. The yield of manganese, under favorable circumstances, was about twenty per cent of the chloride used.

Reduction was also tried by using fused chloride of sodium without fluorspar. The yield of metal was much less, and differing in some of its properties from that obtained with the use of fluorspar. Manganate of soda was formed when sodium chloride alone was used as a flux. Manganese thus obtained is very brittle, with a steel-white fracture so hard that a file will scarcely touch it. The edges of the fractures scratch, and almost cut, glass. The metal retains the brightness of a fractured surface after prolonged exposure to the air, and appears not more disposed to oxidation than iron. It is entirely passive to magnetic attraction.

The specific gravity of the metal obtained when fluorspar was used was 7.072. When remelted under fused sodium chloride, the specific gravity rose to 7.153. The metal obtained without the use of fluorspar was less brittle, and had a different fracture. Its specific gravity was 7.231. Authorities differ regarding the specific gravity of manganese, ranging it from 6.85 to 8.013.

An examination of the metal obtained, using fluorspar as a flux, showed the absence of iron and the presence of calcium, demonstrating the reduction of some of the latter metal from the spar. This may account in a measure for the increased specific gravity on remelting under sodium chloride, as also the greater specific gravity of the metal when the spar was not used. As calcium has the specific gravity of 1.57, a small amount alloyed with the manganese would sensibly affect its gravity.

ETHNOLOGY.

Marriage Ceremonies of the Bilqula.

MR. PH. JACOBSEN, in a letter to his well-known brother, Capt. A. Jacobsen, gives the following description of the marriage ceremonies of the Bilqula of British Columbia. An Indian who intends to marry, calls upon his intended wife's parents, and arranges with them how much he is to pay for permission to marry the girl. Among people of high descent this is done by messengers, sometimes as many as twenty being sent to call on the girl's father. They are sent by the man's parents before the young man is of age. In many instances both man and girl are not more than eight or nine years old. The messengers go in their boats to the girl's house, and carry on their negotiations without going ashore, where the relatives of the girl are standing. The messengers of the young man's parents praise his excellence and noble descent; the great exploits of his father, grandfather, and ancestors; their wars, victories, and hunting expeditions; their liberality at festivals; etc. Then the girl's relatives praise the girl and her ancestors, and thus the negotiations are carried on. Finally a number of blankets are thrown ashore by the messengers; and the girl's relatives protest, and maintain that the number is not sufficient to pay for the permission to marry the girl. In order to obtain their consent, new blankets are thrown ashore one by one, the messengers continually maintaining that the price paid is too great. Generally from twenty to fifty blankets, each of the value of about half a dollar, are paid.

After this the boy and the girl are considered engaged. When they come to be grown up, the young man has to serve a year to his father-in-law. He must fell trees, fetch water, fish, and hunt for the latter. During this time he is called Kos, which means

"one who woos." After a year has elapsed, the marriage is celebrated. At this time great festivals are celebrated. Seven or eight men perform a dance. They wear dancing aprons and leggings, trimmed with puffin-beaks, hoofs of deers, copper plates, and bells. If the groom should be a wealthy man, who has presented to his wife many small copper plates, such as are used as presents to a bride, these are carried by the dancers. The singing-master, who beats the drum, starts a song in which the dancers join. The song used at the marriage festival is sung in unison, while in all other dances each dancer has his own tune and song. The first dancer wears a ring made of cedar-bark. His hair is strewn with eagle-down, which flies about when he moves, and forms a cloud around his head. The groom presents the first dancer with a piece of calico, which the latter tears to pieces, which he throws down in front of each house of the village, crying, "Hoip!" in order to drive away evil spirits. These pieces of calico which he throws down in front of the houses have a lucky meaning, and at the same time express the idea that the groom, when he comes to be a wealthy man, will not forget the inhabitants of any house when giving a festival. The dancers swing their bodies and arms, stamp their feet, and show the copper plates to the lookers-on. Then the bride's father brings a great number of blankets, generally double the number of those he had received from the groom, and gives them to his daughter. The bride orders a few blankets to be spread before the groom. She sits down, and he puts his hand upon her head. Then the groom is given for each of the parts of his body one or more blankets. Finally he is given a new blanket. After the bride's father has given a blanket to each dancer and to the drummer, the villagers are invited to a great feast. At this time groom and bride eat for the first time together.

HEALTH MATTERS.

American Public Health Association.

THE preliminary circular relating to the next meeting of this association has just been issued. The meeting will be held at Brooklyn, N.Y., Oct. 22-25, 1889.

The executive committee have selected the following topics for consideration at said meeting:—1. The causes and prevention of infant mortality. 2. Railway sanitation: (a) Heating and ventilation of railway passenger-coaches; (b) Water-supply, water-closets, etc.; (c) Carrying passengers infected with communicable diseases. 3. Steamship sanitation. 4. Methods of scientific cooking. 5. Yellow-fever: (a) The unprotected avenues through which yellow-fever is liable to be brought into the United States; (b) The sanitary requirements necessary to render a town or city proof against an epidemic of yellow-fever; (c) The course to be taken by local health authorities upon the outbreak of yellow-fever. 6. The prevention and restriction of tuberculosis in man. 7. Methods of prevention of diphtheria, with results of such methods. 8. How far should health authorities be permitted to apply known preventive measures for the control of diphtheria. 9. Compulsory vaccination. 10. Sanitation of asylums, prisons, jails, and other eleemosynary institutions.

Papers upon miscellaneous sanitary subjects not included in the above list will be received by the executive committee, subject to the requirements of the By-Laws. Preference will be given, however, to papers upon the subjects selected by the committee in making up the daily programme of the meeting.

It is confidently expected that the Brooklyn meeting will be the largest and most important ever held by the association. The local committee of arrangements have already organized, and have the preliminary local work well under way. No efforts will be spared to make the meeting a grand success, and every arrangement necessary to the comfort of those attending will be made in ample season.

The growth and work of this association constitute a monument to American hygiene. It was organized in 1872, and has grown to be the largest association of its kind in the world, and embraces in territorial area the United States, the Dominion of Canada, and the Provinces. It has published fourteen large volumes on health subjects, one volume on disinfectants (which is the most complete

work of its kind in the English language), over one hundred and twenty thousand copies of the Lomb Prize essays, besides numerous reprints. The influence of this great work upon the public-health interests of the country can scarcely be estimated.

ICE-WATER.—In the opinion of the editor of *The Sanitary Volunteer*, the official organ of the New Hampshire Board of Health, there is a great deal of sentiment and many opinions, regarding the use of ice-water, that vanish when the light of reason and experience is turned upon them. The fact is, that ice-water, drank slowly and in moderate quantities, constitutes a healthful and invigorating drink. There is no doubt that ice is a great sanitary agent, and every family ought to be provided with it during the warmer months of the year. It is true that the inordinate use of ice-water, or its use under some special conditions and circumstances, is attended with great danger: so is the improper use of any other drink or food. The assumption that iced water is dangerous, and that iced tea, or iced coffee, or iced lemonade is a harmless substitute, is simply a delusion. As the source of danger feared by some is the degree of cold, we fail to see clearly how flavor modifies the effect of temperature. There are some individuals, undoubtedly, who cannot drink ice-water without injury, and who ought never to use it, but to a great majority of persons it is refreshing and healthful. Its use, temperate and discreet, is in no way to be condemned, which cannot be said of some of its substitutes.

THE MORTALITY AMONG NURSES.—The advocates of the non-bacillary origin of tuberculosis have sought support for their position in the immunity often enjoyed by nurses and attendants on the phthisical. That this immunity is the exception, and not the rule, seems indicated by recent studies by Cornet. In the *Zeitschrift für Hygiene*, Cornet publishes the tabulated results of his comparison of the mortality rates in the population of towns and cities and in nurses. These results are summarized in *The Medical News*. A large proportion of German nurses are members of religious orders, who, by reason of their secluded, regular lives, are removed from many causes of acute disease. Such nurses are in the best mental and moral condition to insure health, for which and other reasons the infective diseases ought not to be especially prevalent among them. Care was taken to select orders whose members serve for life and remain celibate. The material collected was from 38 cloisters, embracing an average yearly service of 4,028 women, whose aggregate service in years was 87,450. An examination of this material during twenty-five years revealed 2,099 deaths, 62.88 per cent of which were from tuberculosis, or nearly two-thirds. The usual proportion of deaths from tuberculosis is from one-seventh to one-fifth. Next to tuberculosis comes typhoid, while cancer shows a slightly increased rate of mortality. Death occurred among these nurses at an average age of 36.27 years, an average shorter life than that of workmen exposed to the inhalation of injurious dust, by eight or ten years. The death-rate from tuberculosis among nurses attains its maximum between the thirtieth and fortieth years, and then steadily declines. When a comparison of the death-rate of nurses and the population of a town is made, it is found that between the ages of 15 and 20 the mortality among nurses is four times that of other population; from 20 to 30, three times; from 30 to 40, twice as great; afterward becoming about equal. The explanation of these facts is found in the prevalence of tuberculosis among nurses, it being nine times more frequent than among other classes. All infective diseases are more frequent among nurses until the fortieth year of life, after which their death-rate is lower than that of other classes. It is further shown that during the first six months of service the nurse enjoys comparative immunity from infection. After that, the mortality and morbidity rate steadily rises for three years, during which the greatest number of deaths occur. The life chances of nurses do not compare favorably with others. A nurse beginning her profession at seventeen has twenty-one and a half years of life less than a woman of the same age not exposed to infective diseases. So far as relative age is concerned, a nurse at twenty-five has the chance for life commonly enjoyed at fifty-eight; at thirty-three years, the outlook of a person aged sixty-two.

UNDERGROUND WATER AND BACTERIA.—Underground water and bacteria were the theme of a recent lecture delivered by Dr. C. Fraenkel, assistant to the famous bacteriologist, Dr. Robert Koch, in the Hygienic Institute at Berlin. The gist of the lecture was that the underground water of Berlin is free from bacteria, that this surprising fact is due to the great filtering-power of the ground, and that consequently the water drawn from the artesian wells is perfectly wholesome. These results do not correspond with those obtained in New York, where the water from artesian wells has in many, if not all, cases proved to be impure.

THE FLY AS A DISEASE-CARRIER.—With the bacteriologists, another domestic animal, the fly, is coming in for his share of incrimination for spreading infectious diseases. It has long been known that, if not the house-fly, at least some kinds which are near relations of his, have sometimes been guilty of causing malignant pustule by carrying the contagion of anthrax from diseased animals or animal substances to man. During the past year Dr. Alessi has been experimenting with flies to determine their liability to spread the infection of tuberculosis. The bacillus of this disease was found in the intestines and the excrement of flies which had feasted on tuberculous sputa; and their dried feces, in which, with the aid of the microscope, the bacillus was known to exist, was used for inoculating rabbits, and the animals became tuberculous. Thus it is found that the digestive tract of the fly is harmless to the germ. Spillmann and Haushalter have also made similar researches, with the same results; and lately, according to the *Annals d'Hygiene Publique*, a Mr. Howe, who has studied the subject in the Nile country, has found that the granular ophthalmia of that region can be spread by means of house-flies passing from the eyes of those who are affected with the disease to other persons.

BOOK-REVIEWS.

Principles of the History of Language. By HERMANN PAUL.
Tr. by H. A. Strong. New York, Macmillan. 8°, \$3.

PROFESSOR STRONG has done a service to English readers by translating this work, which contains a more comprehensive survey of the principles of linguistic science and of the methods of studying it than can readily be found elsewhere. It may be said to consist of two parts, though they are not sharply separated. The earlier chapters deal mainly with the general principles of language and the chief determining causes of its development, while in the later ones these principles are followed out into their applications, and discussed with great fulness of detail, and wealth of illustration. Professor Paul has a very clear and correct conception of his favorite science, of its relation to the other sciences, and of the right mode of studying it. The science of language is not an exact science, much less a physical science, as Professor Max Müller maintains, but a department of history. Its principal-basis is psychology, and the leading facts with which it deals are groups of ideas. The physical factor, however, must not be ignored; for language consists of spoken sounds, and it is only through the medium of the material world that we are able to communicate with our fellowmen. Nevertheless, the chief factor in its development is not the body, but the mind, and mind as it exists in society.

Having thus clearly indicated the scope and method of the science, Professor Paul goes on to state the leading causes of linguistic development. One of the chief of these is the tendency to sound-change; that is, to variability of pronunciation, which arises from slight changes in muscular action due to variations in the sensations attending such action. Another potent cause is change in the signification of words, which is perpetually going on, and which enriches the expressive power of language incalculably without adding any new words. This change in the signification of words is sometimes a restriction of the original meaning, sometimes an extension of it; while in other cases it takes the form of metaphor or some other figure of speech. Analogous to those developments are the numerous changes in syntax, while another and perhaps still more potent agent in the development of speech is composition, leading to inflection and word-formation. Professor

Paul also maintains, with many other scholars, that the power of original creation in language is by no means lost, but is as active to-day as ever; and he gives many examples of words of recent origin which he holds to be underived from any others. All original creations, both earlier and later, he believes to be imitative, so that on this point he is directly at issue with many other philologists. These are the fundamental causes of the development of language; but to these must be added analogy, which has a powerful influence by multiplying forms and usages that have arisen in some other way.

Having thus traced the outline of his subject, Professor Paul pursues it into all its ramifications through a series of chapters, which we have not space to analyze here, but which are sure to interest every student of philology. In these days, when there is so much superficial writing, it is pleasant to meet with a book at once so thoughtful and so scholarly as this by Professor Paul; and, though there are things in it that are sure to provoke criticism, it will be of great value to all students of the history of language.

Seraphita. By HONORÉ DE BALZAC. Tr. by Katharine P. Wormeley. Boston, Roberts. 12°. \$1.50.

THIS work is another of its author's studies in occultism. The leading character in the story, called sometimes Seraphita and sometimes Seraphitus, is intended as an example of the "twin soul" which we are told every one must have in order to attain to supreme felicity. Hence she is represented as acting in some cases like a woman, and in others as a man, though the reader may think that she doesn't act much like either. To make the bisexual quality still more prominent, this "strange being" is represented in her feminine character as inspiring love in a young man, and in his masculine character as awakening the same sentiment in a young woman. She talks grandiloquent nonsense about heaven, hell, prayer, and other themes of that sort, and at last is "translated" to the spiritual world; and so the story comes to an end. As for the story itself, it has very few incidents, and no interest at all except what attaches to its occult "philosophy," if any one can take an interest in that. For our part, we find it repulsive, like every thing else of the same sort; being neither philosophy nor religion, but a mere mass of fiction put forward as truth. Besides the principal story, the book contains two shorter ones of a similar character, which call for no special remark. There is also a long and wordy introduction by G. F. Parsons, which neither adds to nor elucidates the text, and has, so far as we can see, no reason to be.

La Société Française au Dix-septième Siècle. Ed., with notes, by Thomas F. Crane. London and New York, Putnam. 24°. \$1.50.

THIS book, which is intended primarily for students of French, consists of a large number of extracts giving an account of the new social life that arose in France in the early part of the seventeenth century. Every one knows that society and conversation have long been more important elements in French life than in that of other nations, and have had greater influence on French literature than

on any other. Students of literature and of social life are therefore alike interested in tracing the origin and growth of that society for which France has long been noted, and Professor Crane here offers them help in so doing. He has restricted himself to a portion only of seventeenth-century society, neglecting that of the court entirely, while even some elements of literary society are passed over. The extracts given treat successively of the Hôtel de Rambouillet and the persons who frequented it, of Mademoiselle de Scudéry and her rather pedantic companions, of the affected set who were nicknamed the *Précieuses*, and of the rules of politeness that prevailed in that age. As far as they go, they give a pretty clear view of the society of which they treat, of its follies and foibles, as well as its excellences; and they also show to some extent the growth of literature and the development of literary style. Some passages are almost repulsive from the self-admiration and mutual admiration they exhibit; but these were necessary to give a faithful picture of the times. Professor Crane's introduction gives useful information respecting the leading persons and topics dealt with, and other points of a more special character are treated in the notes. The book is convenient in form, and well printed.

AMONG THE PUBLISHERS.

THE July *Atlantic* opens with an article by Miss Preston, giving an account of the last days of Cicero, one of a series which she has been contributing to the *Atlantic*. Professor N. S. Shaler, who is a person to speak with authority, writes about "The Problem of Discipline in Higher Education," which will be read by student and teacher with equal interest. Mr. H. L. Nelson has an article on the "Speaker's Power," not a consideration of the power of oratory, but the power of the Speaker of the House of Representatives. Mr. W. H. Downes has an interesting paper on the "Old Masters" which may be seen in New York, and it is surprising to find how large a representation can be seen there. Another article is "Books that have Hindered Me," by Agnes Repplier. So much has been written about books that have helped various people, that Miss Repplier has decided to write about the books that did not help her. Among these she mentions "Sandford and Merton," Milton's "Areopagitica," and the "Heir of Redclyffe." The number closes with a knowing article on "Trotting Races," by H. C. Merwin.

— A. D. F. Randolph & Co. will publish at once the Duke of Argyll's work entitled "What is Truth?"

— J. S. Ogilvie has just ready, in his Fireside Series, "The History of the Great Flood at Johnstown, Penn."

— D. Appleton & Co. will publish immediately "Days Out of Doors," by Charles C. Abbott, author of "A Naturalist's Rambles"; "The History of a Slave," a startling picture of slavery in the Barbary States, by H. H. Johnston; and an interesting work on "Stellar Evolution and its Relations to Geological Time," by James Croll.

"Yours, Merily," Marshall P. Wilder.

THE PEOPLE I'VE SMILED WITH.

RECOLLECTIONS OF A MERRY LITTLE LIFE, by MARSHALL P. WILDER. The American Humorist. With two Portraits. Extra cloth, Gilt top, etc., \$1.50.

"Blessed be he who with merry quip, beguiles tedious hours or causes one flower of merriment to bloom in the desert of selfishness and sorrow. . . His name is synonymous with mirth."—*John A. Cockerill, Editor N.Y. World.*

"The book is full of good stories and clever bits of pen portraiture. None can read it and not be amused. It is impregnated with a fund of humor, that is simply irresistible."

IN ANSWER TO REPEATED CALLS, WE HAVE PREPARED AN EDITION IN PAPER BINDING AT 50 CENTS OF THE MOST POPULAR BOOK OF THIS YEAR.

JONATHAN AND HIS CONTINENT.

RAMBLES THROUGH AMERICAN SOCIETY, by MAX O'RELL and JACK ALLYN. Paper, 50 Cents. Cloth, Gilt, etc., \$1.50.

"A volume of sparkle and delight from title page to finish."—*Detroit Free Press.*

"There is not a dull page in it."—*N.Y. World.*

"One reads the book with a perpetual smile on one's face."—*Chicago News.*

"Will be read, talked of, and enjoyed."—*Boston Home Journal.*

Complete Catalogue Free to any Address.

CASSELL & COMPANY, LIMITED, 104 & 106 FOURTH AVENUE, NEW YORK.

THE FORUM FOR JULY.

In the July number of The Forum, Prof. Geo. J. Romanes answers, in behalf of the Darwinians, the criticisms made of the Darwinian doctrine, by Prof. Mivart. It is an important summary of the present position of the best evolutionist thought.

Prof. W. J. McGee, of the U. S. Geological Survey, explains the supply of the different kinds of fuel, with especial reference to deposits in the United States. Other articles are:

The Scholar in American Life. Bishop Henry C. Potter. A Market for Books. Edward Everett Hale. Republican Party Prospects. Senator Justitia S. Morrill. The Ethics of Journalism. W. S. Lilly. The Attitude of the French Canadians. Honoré Beaugrand. Late Theories Concerning Fever. Dr. Austin Flint. Organizations of the Discontented. Richard J. Hinton. Domestic Service. Jennie Cunningham Croy. The Better Side of Anglo-mania. Rev. H. Price Collier.

50 CTS. A COPY. \$5.00 A YEAR.

THE FORUM PUBLISHING CO.,

253 Fifth Ave., New York.

Macmillan & Co's New Scientific Books.

WALLACE'S DARWINISM.

DARWINISM. An Exposition of the Theory of Natural Selection, with some of its Applications. By ALFRED RUSSELL WALLACE, LL.D., F.L.S., author of "The Malay Archipelago," etc., etc. With Map, Portrait, and Illustrations. 12mo, \$1.75.
 "The present work contains the conclusions upon this great subject of thirty years of thought and observation. . . . A contribution of the first importance to the literature of the subject. At the same time it would be difficult to find a book more entertaining to the general reader. He writes with the simplicity and easy mastery which comes of fullness of knowledge. There can be no more interesting guide in that great wonderland of science in which he has been so long one of the chief discoverers."—*New York Times*.

GALTON'S NATURAL INHERITANCE.

NATURAL INHERITANCE. By FRANCIS GALTON, F.R.S., author of "Inquiries into Human Faculty," etc., etc. 8vo, \$2.50.
 Mr. Galton is the highest authority on this subject; a new book by him is an event in the scientific world."—*Boston Advertiser*.
 "Mr. Francis Galton, whose studies in heredity have been lifelong, whose methods are so patient, is the last man in the world to ventilate startling theories or to assert ill-digested things as facts. . . . For perfecting philosophical inquiry, for prudence and good judgment, Mr. Galton is to be considered as presenting the highest examples of modern research."—*New York Times*.

WEISMANN ON HEREDITY.

ESSAYS UPON HEREDITY AND KINDRED BIOLOGICAL PROBLEMS. By Dr. AUGUST WEISMANN. Translated by E. B. Poulton, M.A., F.L.S.; Selmar Schonland, Ph.D., and A. E. Shipley, M.A., F.L.S. 8vo, \$4.00.

THE CHEMISTRY OF PHOTOGRAPHY.

THE CHEMISTRY OF PHOTOGRAPHY. By RAPHAEL MELDOLA, F.R.S., Professor of Chemistry in Finsbury Technical College. With Illustrations. 12mo, \$2.00.
 "Prof. Meldola's work will find a hearty welcome, not only from professional photographers who wish to understand the principles upon which their art is based, but even from chemists and physicists who will find in it no small matter for thought and study. . . . The book deserves very hearty commendation as a popular scientific treatise in the best sense of the term."—*New York Nation*.

SIR WILLIAM THOMSON'S LECTURES.

POPULAR LECTURES AND ADDRESSES ON VARIOUS SUBJECTS IN PHYSICAL SCIENCE. By Sir WILLIAM THOMSON, D.C.L., LL.D., F.R.S.E., Professor of Natural Philosophy in the University of Glasgow. With Illustrations. Vol. I.—Constitution of Matter. *Nature Series*. 12mo, \$2.00.
 "We do not believe that any man of science will rise from the perusal of these papers without a deepening or a shattering of old convictions, and without broader and clearer views of the possibilities of future scientific progress. . . . We await the appearance of the second and third volumes of these papers with great interest."—*Nation*.

THE PLEASURES OF LIFE. Part II.

THE PLEASURES OF LIFE. Part 2. By Sir JOHN LUBBOCK, Bart., M.P., D.C.L., etc. 12mo. Paper, 35 cents; Cloth, 60 cents.

Contents.

Ambition.	Labor and Rest.	Beauties of Nature.	Poetry.
Love.	Wealth.	Religion.	Troubles of Life.
Music.	Art.	Health.	Hope of Progress.

The Destiny of Man.

THE PLEASURES OF LIFE. Parts 1 and 2. Complete in one volume. Cloth, \$1.25.
 "Really admirable. . . . Sir John Lubbock writes in a charming style. . . . A pleasanter little book than this is seldom published. It is at once suggestive and bracing. It settles no deep and dark problem, indeed, but treats the varying phases and vicissitudes of life with a broad and hopeful philosophy, and from points of view the sustained elevation of which adds much to the effect of the whole."—*N. Y. Tribune*.

GLEANINGS IN SCIENCE.

A SERIES OF POPULAR LECTURES ON SCIENTIFIC SUBJECTS. By GERALD MOLLOY. Crown 8vo, \$2.25.

Contents:

I. The Modern Theory of Heat.	II. Lightning, Thunder, and Lightning-Conductors.	III. The Storing of Electrical Energy.
IV. The Sun as a Storehouse of Energy.	V. The Electric Light.	VI. The Glaciers of the Alps.

The lectures are followed by an appendix giving a short account of the recent controversy on Lightning-Conductors.
 The *Literary World* says:—"The object of Dr. Molloy is not to present the discoveries of an original investigator, but to give to the ordinary public an interesting account of recent progress in various branches of physical science. In this the lecturer has been very successful, for the book is very pleasant to read."
 The *Spectator* says:—"Perhaps the lectures on the 'Electric Light' form the most interesting portion of this book, inasmuch as they make us familiar with the methods of appliances to which we owe the marvels of electric lighting. . . . They are arranged in a masterly manner, all the most essential facts representing the production of the electric current, and the marvellous applications by which the current is made to yield the electric light. . . . All the lectures contained in this volume are pervaded by a philosophical spirit which gives a sort of unity to the various subjects outwardly unconnected of which they treat."

Macmillan & Co.'s Complete Catalogue of Publications will be sent free by Mail to any address on application.

MACMILLAN & CO., 112 Fourth Avenue, New York.

—Miss May Kendall, the young English poetess whose semi-humorous, semi-pathetic fantasies, originally contributed to *Longmans' Magazine* and *Punch*, were recently gathered into a volume called "Dreams to Sell," has now written her first novel, "Such is Life." It will be published shortly by Longmans, Green, & Co., both in London and New York.

—Messrs. Macmillan & Co. are publishing a series of "English Classics," consisting of selections from the leading writers in prose and verse, and supplied with numerous and quite elaborate notes. They are edited by various teachers in the colleges of India, and are more particularly intended for Indian students. We some time ago noticed one of the volumes of the series, — the two opening books of "Paradise Lost;" and we have now received another, — "Essays written in the Intervals of Business," by Arthur Helps, edited by Professors F. J. Rowe and W. T. Webb of Calcutta. The essays are of the easy and somewhat commonplace kind which their author was accustomed to write; but they contain many apt remarks, and to certain minds will doubtless be useful. They treat of every-day matters, such as "Practical Wisdom," "Self-Discipline," "Advice," "The Education of a Man of Business," etc., and are written in a smooth and pleasant style. The editors' notes are very full, consisting of analyses and explanations, and supplying all the information that any reader of the essays can possibly require.

—J. B. Lippincott Company announce the early publication of a midsummer novel called "Three Days," by Samuel Williams Cooper. The book will be beautifully gotten up, and fully illustrated by Hal Hurst and C. C. Cooper, jun., the well-known artists.

—Houghton, Mifflin, & Co. have just ready, in the series of American Statesmen, "George Washington," by Henry Cabot, in two volumes. Mr. Cabot has made a thorough study of the civil career and influence of Washington, and his work cannot fail to shed much light on the interior discussions and vexed questions which filled the years preceding, during, and following the Revolution. They have also just ready Edward Bellamy's "Looking Backward," translated into German by Rabbi Solomon Schindler; the

eight part of the third series of W. H. Edwards's handsome work on "The Butterflies of North America;" and two more volumes. in their Library Edition of Thackeray's works, — "Memoirs of Yellowplush" and "Burlesques, etc."

—Cassell & Co. will publish next month, from their London house, "The Year-Book of Commerce." This work, prepared especially for business-men, will form an annual statistical volume of reference, showing the movement of the foreign trade and general economic position of the leading countries of the world. It has been compiled under the authority of the London Chamber of Commerce, and is edited by Mr. Kenric B. Murray. Among the contributors will be Lord Brassey, Dr. R. Giffen, H. C. Burdett (secretary to the Stock Exchange), Mr. J. S. Jeans (secretary to the Iron Trade Association), Major Craigie (secretary to the Central Chamber of Agriculture), Mr. George Martineau, Mr. John Corbett, Mr. E. D. Milliet (of Berne, Switzerland), Mr. Boverton Redwood, Signor Luigi Bodeo (Rome), Dr. Becher (Berlin), M. E. Fournier de Flaux (Paris), etc.

—Messrs. Ginn & Co. announce, in the College Series of Greek Authors, Plato's "Protagoras," the commentary of Sauppe, translated, with additions, by Principal Towle of Norfolk, Conn. The "Protagoras" is perhaps the liveliest of the dialogues of Plato. In few dialogues is the dramatic form so skilfully maintained without being overborne by the philosophical development. By the changing scenes, the variety in the treatment of the theme, and the repeated participation of the bystanders, the representation of a scene from real life is vivaciously sustained. Noticeable, too, is the number of vividly elaborated characters: Socrates ever genial, ready for a contest, and toying with his opponents; Protagoras, disdainful toward the other sophists, condescending toward Socrates; Prodicus, surcharged with synonymic wisdom; Hippias, pretentious and imposing; the impetuous Alcibiades; and the tranquil Critias. Herr Geheim-Rath Sauppe is the Nestor of German philologists, and his introduction and commentary have been accepted as models by scholars. In this edition, those additions have been made which seemed desirable for the use of American classes.

GUARANTY INVESTMENT COMPANY

CAPITAL \$250,000.

Hon. ALBERT H. HORTON (Chief Justice, Kansas Supreme Court), Topeka, Kan., Pres't.

7% Guaranteed Farm Mortgages 7%

The Company calls the special attention of Investors to the following points:

- I. All loans guaranteed and interest payable semi-annually at the Importers' & Traders' National Bank, New York.
- II. Unusual fulness of information, not only about the security itself, but about the general development of the section where the farm is located.
- III. An examination each year of the general business of the Company and the Mortgages themselves by a COMMITTEE OF INVESTORS sent for the purpose.
- IV. Many hundred Mortgages taken and NOT A SINGLE FORECLOSURE.
- V. Exhibitions in New York at frequent intervals, of Kansas and Nebraska Farm Products. The Exhibition at the American Institute in the fall of 1888, received the *HIGHEST AWARD* of superiority.
- VI. Monthly Bulletins giving full information about all Mortgages offered for sale.

Address for Monthly Bulletin and Investors' Committee Report for 1888,

HENRY A. RILEY, General Eastern Manager, 191 Broadway, N.Y.

DAFT ELECTRIC LIGHT COMPANY.

Power Stations.

Electric Railways.

Stationary Motors

1/2 to 100 H.P.

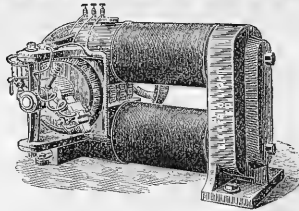

Car Motors 15 to

250 H.P.

Executive Office, 115 Broadway, N.Y.
FACTORY, JERSEY CITY, N.J. Please Mention "Science."

The Mutual Life Insurance Company

OF NEW YORK.

RICHARD A. McCURDY, PRESIDENT.

ASSETS - - - \$126,082,153 56

The Largest and best Life Insurance Company in the World.

The New Business of the Mutual Life Insurance Company in 1888

Exceeded \$103,000,000.

Its Business shows the Greatest Comparative Gain made by any Company during the past year including

A gain in assets of.....	\$ 7,275,301 68
A gain in income of.....	3,096,010 06
A gain in new premiums of.....	2,333,406 00
A gain in surplus of.....	1,645,622 11
A gain in new business of.....	33,750,792 85
A gain of risks in force.....	54,496,251 85

The Mutual Life Insurance Company

Has Paid to Policy-holders since Organization \$272,481,839 82.

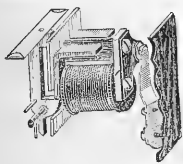

A
★
DROP
IN THE
PRICE
★ OF

GRAVITY DROP ANNUNCIATORS.

DON'T FORGET THE
DUST-PROOF BELLS.

HAZAZER & STANLEY,

32 Frankfort Street, N. Y.

Mineral Lands.

MANGANESE DEPOSITS. — A rich deposit of Manganese is for sale. Apply to H. N., care of Science, 47 Lafayette Place, New York.

GOLD-BEARING QUARTZ VEINS. — Any one wishing to engage in gold mining will learn of a newly discovered vein by applying to H. N., care of Science, 47 Lafayette Place, New York.

RED SLATE. — A valuable deposit of red slate for sale. Apply to H. N., care of Science, 47 Lafayette Place, New York.

A POCKET WRENCH



AND SCREW DRIVER COMBINED.
Turns Nuts, Gas Burners or Pipe without adjustment.
Made of Best Polished Steel. Sent by mail for 25cts.
POCKET WRENCH CO., P. O. Box 62, New York City.

PATENTS.

Until October 1st, my fees, as attorney, due only on allowance if desired. Write
W. H. BARCOCK,
513 Seventh St., Washington, D. C., P. O. Box 220.
Formerly Examiner in Patent Office.
THIRTEEN YEARS' PRACTICE.

THE

American Bell Telephone COMPANY.

95 MILK ST., BOSTON, MASS.

This Company owns the Letters Patent granted to Alexander Graham Bell, March 7th, 1876, No. 174,465, and January 30, 1877, No. 186,787.

The Transmission of Speech by all known forms of ELECTRIC SPEAKING TELEPHONES infringes the right secured to this Company by the above patents, and renders each individual user of telephones, not furnished by it or its licensees, responsible for such unlawful use, and all the consequences thereof and liable to suit therefor.

OUR 75 CENT COLORED SILK.

We have had unusual success with this line of Gros Grains.

They are 19 1-2 inches wide, have a fine cord weave, and are in 40 different, excellent shades. Under ordinary circumstances they would sell for \$1 per yard.

Send for samples; they will surely please you.

JAMES MCCREERY & CO.

BROADWAY AND ELEVENTH STREET,
NEW YORK.

C. & C. ELECTRIC MOTOR COMPANY.

Electric Motors
FOR
Arc and Incandescent
Circuits, Most Eco-
nomical Motor on
the Market.
Regulation Perfect.
Motors Designed for all
Power Purposes.

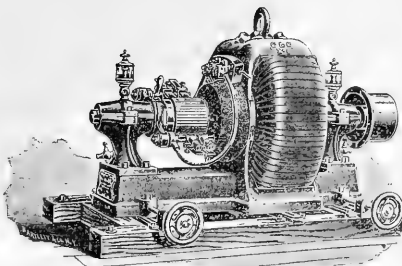

OFFICE and MANUFACTORY:
402 and 404 Greenwich Street, New
York City.
New England Office, 19 Pearl St., Boston.
Philadelphia Office, 301 Arch St.
Western Office, 139-141 Adams Street,
Chicago.
Southern Office, 25 Carondelet Street,
New Orleans.

16 PAGES. **THREE** 16 PAGES.

Hundred Thousand new subscribers for *The Family Journal and Ladies' Companion* wanted. It is the most interesting and instructive paper ever issued. Subscribers will receive during the coming twelve

MONTHS

novels written by American Authors, complete in each three numbers. The story of popular works of fiction will be retold by a novel reader, the most interesting and unique feature ever introduced in any publication, giving the substance of popular and standard books by famous writers in a space easily read by the busiest people. We have engaged

FOR

this work a widely known and popular writer. Comments on Current Events, Fashions, New and Original Ideas and Designs for Ladies' Fancy Work and Household Decoration, Letters from Correspondents and their Answers. The colleges and seminaries of the United States will be treated one each month in an illustrated article, showing the particular advantage of each, cost of attendance, etc. Invaluable to parents having sons or daughters whom they desire should receive the advantages of a higher education than the ordinary school affords. Articles on Painting and Drawing, giving home instruction by a well-known artist. A trial subscription of this elegant paper will be sent to any address, three months, for

TEN CENTS.

Liberal pay for literary work adapted to our columns, and for new and original drawings, designs and ideas on any subject which we can use. From our list the most complete in the world. We offer inducements to club raisers and agents approached by no other publishing house. The celebrated Gilbert Cuy Waist Linings, which we send post paid to any one sending us two yearly subscribers at 60 cents each is alone worth 70 cents. For sent to any address, post paid one year, 50 cents; six months, 25 cents, and a three months' trial subscription for only 10 cents.

TRY IT! TRY IT! TRY IT!

and you will become a permanent reader. Address:

**John L. Douglass, Publisher,
322 Broadway, N. Y.**

ESTABLISHED 1859.

H. A. DREW,

Commercial Printer,

5 Clinton Place, near Broadway,
New York.

Wedding Orders, Souvenirs, Invitations, Orders of Dance, etc., etc., done in the latest and most elaborate styles, at reasonable prices.

All Favors promptly attended to.



GOOD NEWS TO LADIES.

Greatest inducements ever offered. Now's your time to get up orders for our celebrated **Tea and Coffee**, and secure a beautiful Gold Band or Moss Rose China Tea Set, Dinner Set, Gold Band Moss Rose Toilet Set, Watch, Brass Lamp, or Webster's Dictionary. For full particulars address **THE GREAT AMERICAN TEA CO.,** P. O. Box 229, 31 and 33 Vesey St., New York.

Scientific Apparatus.

J. GRUNOW,

621 Sixth Avenue, New York.
Established 1852.

MAKER OF

Microscope Stands,
Oil Immersion Objectives and Abbe Condensers for Bacterial and Histological work, of Objectives, Camera Lucida and other accessory apparatus.

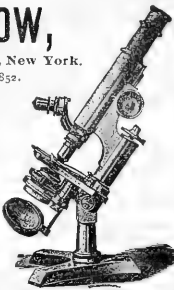

MORRIS EARLE & CO.

SUCCESSORS TO

R. & J. BECK,

1016 Chestnut Street, Phila.

Microscopes and all Accessories and Apparatus, Photographic and Photo-Micrographic Apparatus and Outfits.

Spectacles, Eye Glasses, Opera and Marine Glasses, etc.

Illustrated Price List mailed free to any address. Mention *SCIENCE* in corresponding with us.

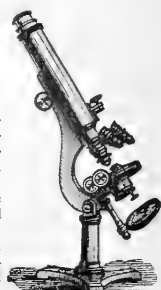

IMPROVED OIL LIGHT MAGIC LANTERNS.

Also Lime and Electric Light Apparatus, and mechanical, plain, and fine colored views.

J. B. COLT & CO., Manufacturers,
No. 16 BEEKMAN STREET, NEW YORK.



E. & H. T. ANTHONY & CO.
591 Broadway, N. Y.

Manufacturers and Importers of PHOTOGRAPHIC INSTRUMENTS, Apparatus and Supplies of every description. Sole proprietors of the Patent Detective, Fairy Novel, and Bicycle Cameras, and the Celebrated Stanley Dry Plates.

Amateur Outfits in great variety, from \$300 upward. Send for Catalogue or call and examine. *SCIENCE* More than 40 years established in this line of business.

A NEW MICROSCOPE.

Having invented an improved form of microscope, I will assign an interest in the patent for financial assistance in manufacturing. It is believed that a powerful instrument may be made on the new principle at low cost.

FRANK ANTON BECKER, 530 E. 16th St., N. Y.

A TEMPORARY BINDER

for *Science* is now ready, and will be mailed postpaid on receipt of price.

Half Morocco - 75 cents.



This binder is strong, durable and elegant, has gilt side-title, and allows the opening of the pages perfectly flat. Any number can be taken out or replaced without disturbing the others, and the papers are not mutilated for subsequent permanent binding. Filed in this binder, *Science* is always convenient for reference.

N. D. C. HODGES,
47 Lafayette Place, N. Y.

Wants.

A YOUNG MAN can have lucrative engagement, not only a fixed salary, but according to his work accomplished in travelling for *SCIENCE*. A personal interview invited.

N. D. C. HODGES,
47 Lafayette Place, New York.

Old and Rare Books.

One Million Magazines. Back numbers, vols. and sets—old and new, Foreign and American. CATALOGUE UPON APPLICATION.

A. S. CLARK,

34 Park Row, New York City.

BACK NUMBERS and complete sets of leading Magazines. Rates low. AM. MAG. EXCHANGE, Schoharie, N. Y.

Schools.

CONNECTICUT, NEW HAVEN,

MRS. CADY'S SCHOOL FOR YOUNG LADIES. Prepares for Smith and Wellesley, and admits to Vassar by Certificate. Circulars. Early application necessary.

NEW JERSEY, PLAINFIELD.

THE CHESTNUTS.—Parents with daughters to educate, or orphan girls with companion, may find a comfortable home, with school instruction by applying to Miss E. E. Kenyon.

Sprague Electric Railway and Motor Company.

Lightest Weight Consistent with
Highest Efficiency.

SIMPLE IN CONSTRUCTION.

Not Liable to get out of Order.

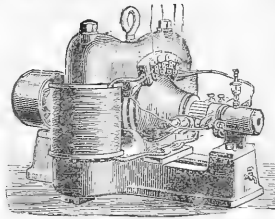

Bearings Self Oiling.

NON-SPARKING IN OPERATION.

Commutator Wear Reduced
to a Minimum.

16 and 18 BROAD STREET, NEW YORK.

NO OTHER Life Policies as liberal cost as little money, no others as cheap give as much for the money, as those of

THE TRAVELERS OF HARTFORD, CONN.

Best either for Family Protection or Investment of Savings. Non-forfeitable, world-wide, lowest cash rate.

All claims paid without discount, and immediately on receipt of satisfactory proofs.

Assets,
Surplus,

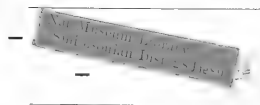

\$10,383,000.
\$2,041,000.

JAS. G. BATTERSON, President.

RODNEY DENNIS, Secretary.



**KIMBALL'S
STRAIGHT CUT
CIGARETTES**
Unsurpassed in quality.
Used by people of refined taste.
Highest award at Brussels, 1889.
The finest smoking mixtures are of
our manufacture.
Fifteen First Prize Medals.
WM. S. KIMBALL & CO.,
Rochester, N. Y.

FOOD ADULTERATION

And its Detection. With photomicrographic plates and a bibliographical appendix. By J. P. Battershall, 328 pages, 8vo. cloth. Price, \$3.50. Circulars and Catalogues on application. E. & F. N. SPON,
12 Cortlandt St., New York.

ESTERBROOK'S STEEL PENS.

OF SUPERIOR AND STANDARD QUALITY.
Leading Nos.: 048, 14, 130, 135, 239, 333
For Sale by all Stationers.

THE ESTERBROOK STEEL PEN CO.,
Works: Camden, N. J., 26 1/2 1/2 St., New York.

SOMETHING NEW
THE PATENT
ADJUSTABLE DRUSH.

THE BEST LIQUID GLUE
ALWAYS READY FOR USE
THE PATENT ADJUSTABLE DRUSH

Patent Pocket Can. No waste

**THE STRONGEST
GLUE**
IN THE WORLD.
2 GOLD MEDALS
RUSSIA & ST. LOUIS 1904

Used by thousands of first-class mechanics and by such manufacturers as Pullman Palace Car Co., Mason & Hamlin Organ and Piano Co., &c., &c.

Repairs Everything.
Its success has brought a lot of imitations copying us in every way possible. Remember that **THE ONLY GENUINE LePage's Liquid Glue** is manufactured solely by the **RUSSIA CEMENT CO.** GLOUCESTER, MASS.

Send 10c. and dealers' card who don't keep it in stock, for sample.

IMPROVING THE MEMORY PICK

and facilitating the acquirement of knowledge by lectures and correspondence. Classes forming, "MEMORY and its Doctors," from Simonides to "Loisette," mailed for 25 cents (New Edition).

DR. PICK, 24 Union Square, N. Y. City.

5 19

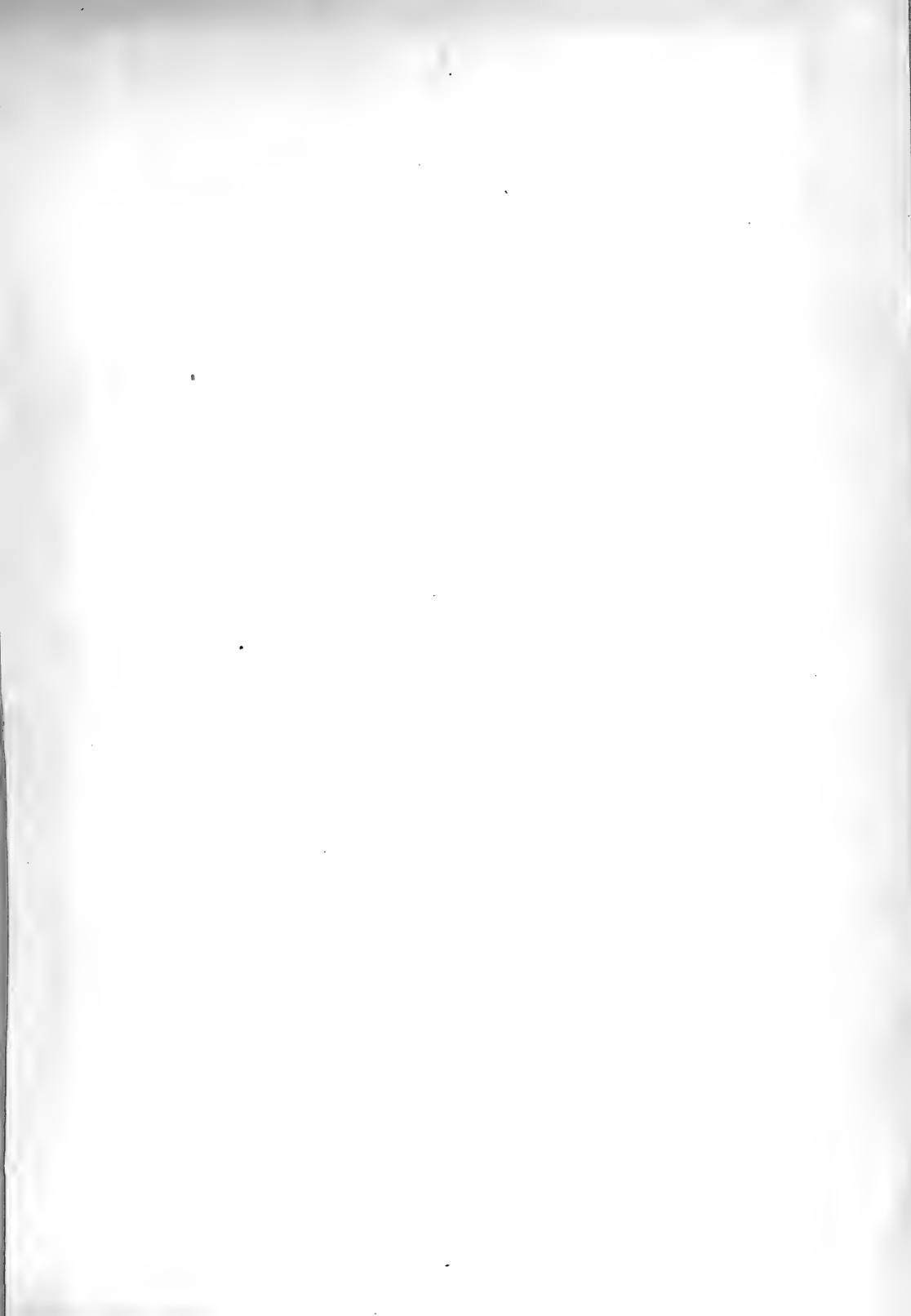

SMITHSONIAN INSTITUTION LIBRARIES



3 9088 01301 4048