

R 11  
6446

HARVARD UNIVERSITY



Library of the  
Museum of  
Comparative Zoology











[August, 1898.]

THE  
SCIENTIFIC TRANSACTIONS



OF THE

ROYAL DUBLIN SOCIETY.

VOLUME VII.—(SERIES II.)

MUS. COMP. ZOOLOGICAL  
LIBRARY

APR 5 1894

HARVARD  
UNIVERSITY

---

I.

A DETERMINATION OF THE WAVE-LENGTHS OF THE PRINCIPAL LINES  
IN THE SPECTRUM OF GALLIUM, SHOWING THEIR IDENTITY WITH  
TWO LINES IN THE SOLAR SPECTRUM. By W. N. HARTLEY, F.R.S.,  
AND HUGH RAMAGE, A.R.C.Sc.I.

(PLATE I.)

---

DUBLIN:

PUBLISHED BY THE ROYAL DUBLIN SOCIETY.

WILLIAMS AND NORGATE,

14, HENRIETTA STREET, COVENT GARDEN, LONDON:

20, SOUTH FREDERICK STREET, EDINBURGH; AND 7, BROAD STREET, OXFORD.

PRINTED AT THE UNIVERSITY PRESS, BY PONSONBY AND WELDRICK.

1898.

---

*Price One Shilling.*

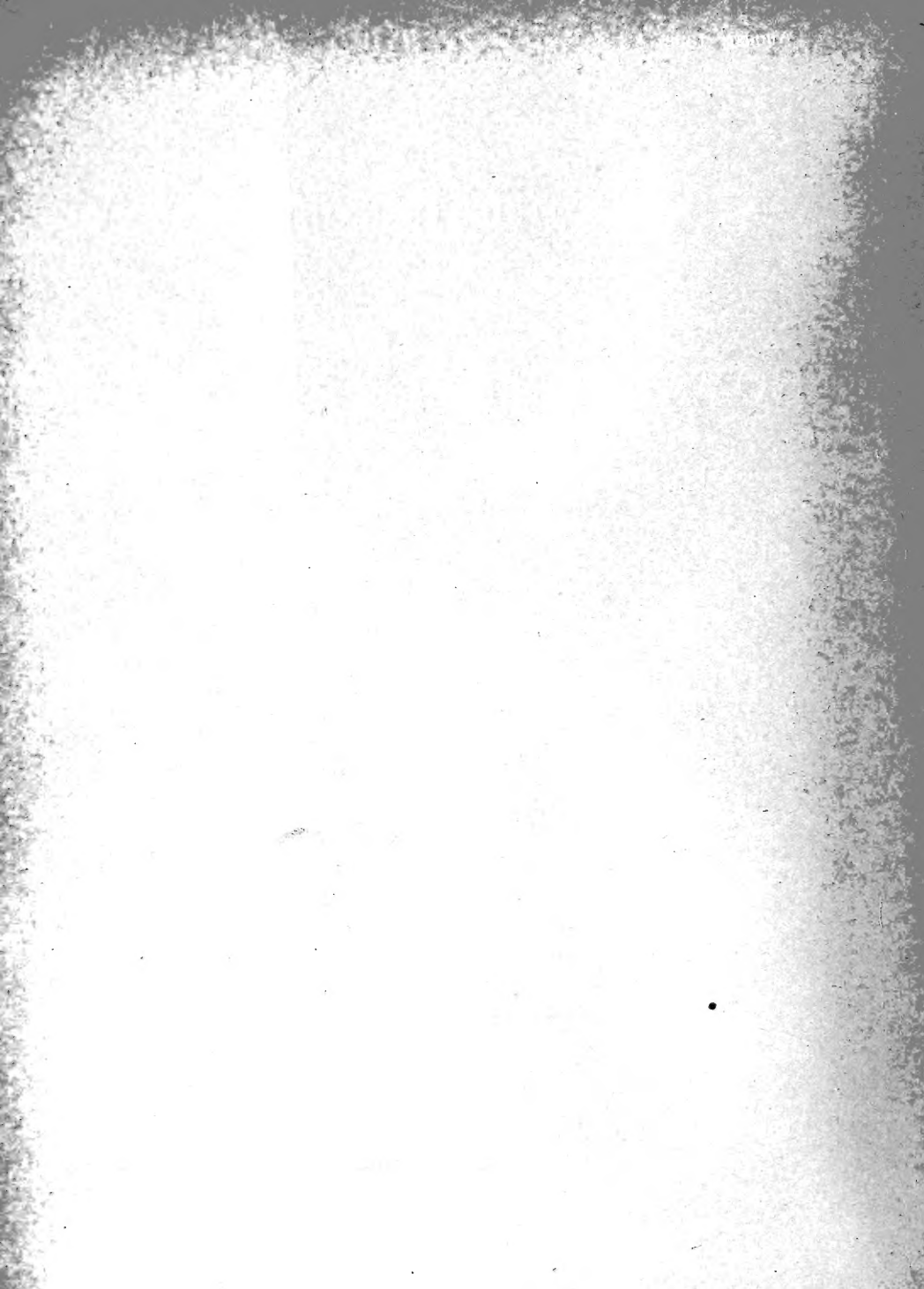

## INDEX SLIP.

---

HARTLEY, W. N., and RAMAGE, Hugh.—A Determination of the Wave-lengths of the principal Lines in the Spectrum of Gallium, showing their identity with two Lines in the Solar Spectrum.  
Roy. Dublin Soc. Trans., S. 2, vol. 7, 1898, pp. 1-6.

RAMAGE, Hugh, and HARTLEY, W. N.—A Determination of the Wave-lengths of the principal Lines in the Spectrum of Gallium, showing their identity with two Lines in the Solar Spectrum.  
Roy. Dublin Soc. Trans., S. 2, vol. 7, 1898, pp. 1-6.

Gallium, Determination of the Wave-lengths of the principal Lines in the Spectrum of.  
Hartley, W. N., and Ramage, Hugh.  
Roy. Dublin Soc. Trans., S. 2, vol. 7, 1898, pp. 1-6.

Wave-length, principal Lines in the Spectrum of Gallium.  
Hartley, W. N., and Ramage, Hugh.  
Roy. Dublin Soc. Trans., S. 2, vol. 7, 1898, pp. 1-6.

INDEX SHEET

HARTLEY, W. N., and RAMAGE, HUGH.—A Determination of the Wave-lengths of the principal lines in the Spectrum of Gallium, showing their identity with two lines in the Solar Spectrum.  
Roy. Dublin Soc. Trans., S. 2, vol. 7, 1898, pp. 1-9.

HARTLEY, W. N., and RAMAGE, HUGH.—A Determination of the Wave-lengths of the principal lines in the Spectrum of Gallium, showing their identity with two lines in the Solar Spectrum.  
Roy. Dublin Soc. Trans., S. 2, vol. 7, 1898, pp. 1-9.

HARTLEY, W. N., and RAMAGE, HUGH.—A Determination of the Wave-lengths of the principal lines in the Spectrum of Gallium, showing their identity with two lines in the Solar Spectrum.  
Roy. Dublin Soc. Trans., S. 2, vol. 7, 1898, pp. 1-9.

HARTLEY, W. N., and RAMAGE, HUGH.—A Determination of the Wave-lengths of the principal lines in the Spectrum of Gallium, showing their identity with two lines in the Solar Spectrum.  
Roy. Dublin Soc. Trans., S. 2, vol. 7, 1898, pp. 1-9.

[AUGUST, 1898.]

THE  
SCIENTIFIC TRANSACTIONS  
OF THE  
ROYAL DUBLIN SOCIETY.

VOLUME VII.—(SERIES II.)

---

I.

A DETERMINATION OF THE WAVE-LENGTHS OF THE PRINCIPAL LINES  
IN THE SPECTRUM OF GALLIUM, SHOWING THEIR IDENTITY WITH  
TWO LINES IN THE SOLAR SPECTRUM. By W. N. HARTLEY, F.R.S.,  
AND HUGH RAMAGE, A.R.C.Sc.I.

(PLATE I.)

---

DUBLIN:  
PUBLISHED BY THE ROYAL DUBLIN SOCIETY.  
WILLIAMS AND NORGATE,  
14, HENRIETTA STREET, COVENT GARDEN, LONDON;  
20, SOUTH FREDERICK STREET, EDINBURGH; AND 7, BROAD STREET, OXFORD.  
PRINTED AT THE UNIVERSITY PRESS, BY PONSONBY AND WELDRICK.

1898.





# SCIENTIFIC TRANSACTIONS

OF THE

## ROYAL DUBLIN SOCIETY.

---

VOLUME VII.

---

### I.

A DETERMINATION OF THE WAVE-LENGTHS OF THE PRINCIPAL LINES IN THE SPECTRUM OF GALLIUM, SHOWING THEIR IDENTITY WITH TWO LINES IN THE SOLAR SPECTRUM. BY W. N. HARTLEY, F.R.S., AND HUGH RAMAGE, A.R.C.Sc.I.

(PLATE I.)

[Read MARCH 16, 1898.]

It having been shown by us\* in the examination of a number of minerals, such as felspar, mica, basalt, pumice from Krakatoa, volcanic dust from New Zealand, iron ores, aluminous minerals, and of meteoric iron and meteoric dust, that gallium is a common constituent, present only in small proportion, it seemed of interest to determine whether traces of this element are to be found in the solar spectrum.

In order to test this matter by a more accurate investigation than is possible with ordinary instruments, we have been glad to avail ourselves of the very kind offer of assistance made by Dr. W. E. Adeney, Curator of the Royal University of Ireland. He has afforded us the means of photographing spectra with the fine Rowland concave grating of twenty-one and a-half feet radius which has been mounted in the Physical Laboratory of the University. The instrument was adjusted so that we could photograph on one plate,  $19\frac{1}{2}$  inches long, the region, in the second order, between wave-lengths 3990 and 4500. Cadet "Lightning plates" were used, and they were developed with hydroquinone.

\* Proc. Royal Society, vol. 60, pp. 35 and 393. Trans. Chemical Society, 1897, pp. 533 and 547. Journal Iron and Steel Institute, 1897, No. ii., p. 182. Scientific Proc. Roy. Dub. Soc., vol. viii. (N.S.), Part vi., No. 68.

We were under the necessity of obtaining a specimen of pure iron for the purpose of obtaining a spectrum of this metal perfectly free from gallium, manganese, and one or two other elements, such as chromium, with which it is usually associated. For this purpose we made use of the iron in a pulverulent form, which is separated from potassium ferrocyanide when this substance is fused with potassium carbonate, and the black powder is separated from the potassium cyanide by solution in water or alcohol, and afterwards washed and dried. We believe this to be the purest form of iron which has yet been made.

To use it in the arc, we are obliged to ram it into carbon tubes, by which treatment it is unfortunately contaminated with carbon, but we have not found other impurities introduced. We have used also the iron residue obtained by the simple ignition of potassium ferrocyanide, the carbon of which must be very pure. For oxyhydrogen flame spectra, it is rolled up in ashless filter-papers and burnt in the flame.

From our knowledge of the spectrum of gallium and of the proportion present in the minerals containing it, we concluded that it would probably be useless attempting to find any lines in the solar spectrum other than the two well-known lines of wave-lengths about 4172 and 4033. We found that the less refrangible of these lines is nearly coincident with an iron line in the arc spectrum of iron and in the solar spectrum, and that the second and more refrangible line is nearly coincident with an iron-manganese line in the solar spectrum. In a case of this kind, where the lines are very feeble and very closely adjacent to others, mere coincidence observed by photographing metallic spectra along with that of the sun is not so satisfactory as actually determining the wave-lengths by measurements. The following is a list of the photographs taken with the Rowland grating:—

Plate I.—(1) Solar spectrum.

(2) Blast furnace iron containing  $\frac{1}{30000}$ th of its weight of gallium, an arc spectrum.

These spectra cannot be considered as showing absolute coincidences with the gallium lines. The arc spectrum contains a very large number of lines belonging to iron, but those of gallium are not distinctly visible, because the iron lines lie over them.

Plate II.—(1) Spark spectrum taken from a solution of gallium chloride between platinum electrodes. Exposure 15 minutes.

(2) Solar spectrum showing where coincidences might be looked for.

This photograph gives the relative intensities of the two lines, the less refrangible being the stronger.

Plate III.—A second plate with the same two spectra, a band of the solar spectrum running through the middle of the spectrum, and a second one touching the edges of the lines.

- Plate IV.—(1) An arc spectrum of pure iron, the metal being prepared from potassium ferrocyanide, by fusion with potassium carbonate.
- (2) The same.
  - (3) The same, with a large proportion of the residue obtained on ignition of gallium ferrocyanide.
  - (4) Similar to (3), but with a smaller proportion of gallium.
  - (5) Solar spectrum photographed on the succeeding day, the sun at the time being too low to show possible coincidences.

In (3) and (4), the gallium lines are beautifully reversed; but in (4), the lines are broad and the reversals much less marked. The reversed lines of gallium are clearly seen to correspond with reversals in the solar spectrum; but the reversals may probably be those of iron lines very closely adjacent to those of gallium.

- Plate V.—(1) Arc spectrum of pure iron from ferrocyanide, with the addition of a gallium compound, on the middle portion only. The solar spectrum is taken with the middle portion cut out.
- (2) Arc spectrum of a small quantity of a gallium compound and a small quantity of the iron also, with the solar spectrum as in (1).

In the oxyhydrogen flame, arc and spark spectra of substances both poor and rich in gallium, the line 4172 is always stronger than 4033.

By measurements of the iron lines and the gallium lines in arc spectra of materials containing different proportions of the two metals, the wave-lengths of the two gallium lines were determined by interpolation from the iron lines. The wave-lengths of the latter used were those determined by Rowland in the solar spectrum. By this method, the wave-lengths of the reversed gallium lines are found to be 4172·214 and 4033·125. These numbers are higher than those obtained by Lecocq de Boisbaudran in the spark, and higher also than our measurements of the lines in the oxyhydrogen spectra photographed with very small dispersion, namely, 4171·6 and 4032·7; but they have been verified to the second decimal place by different measurements.

In Rowland's Table of Solar Spectrum Wave-lengths, published in the "Astro-Physical Journal," vol. i., pp. 139 and 225, there are two lines corresponding to these; but, to judge of the probability of these lines belonging to the element gallium, it is necessary to consider their relative intensities. Rowland measures

the intensities of the solar lines over a wide scale, extending from 1, a line just clearly visible on the map, to 1000, for the H and K lines; and it is remarked that this is hardly enough for the enormous differences in intensity. Below 1, the lines, in the order of faintness, proceed from 0 to 0000, indicating lines more and more difficult to see. The lines in his table which lie near to the two measured lines in the arc spectrum of gallium are the following:—

## SOLAR LINES.\*

$\lambda$	Intensity.
4171·854, Cr, La, Mn, Ni, Fe, . . . . .	3
4172·066, Ti, Fe, . . . . .	2
4172·211, Al (?), . . . . .	1
4172·296, Fe, . . . . .	2
$\lambda$	
4032·610, Fe, . . . . .	2
4032·789, Fe, . . . . .	4
4032·985, . . . . .	000
4033·112, . . . . .	00
4033·224, Fe, Mn, S., . . . . .	7d.

We find that the lines in the solar spectrum most nearly coincident with the gallium lines, according to our determinations of their wave-lengths, are the following:—

Solar Lines.	Intensity.	Gallium Lines.	Intensity.
4172·211, Al, † . . . . .	1	4172·214	1
4033·112, . . . . .	00	4033·125	00

We believe these numbers to be quite accurate to the second decimal place. Our micrometer measures to the ten-thousandth of an inch, and an error of this magnitude makes a difference of 0·0033 in the wave-length. We used lines in the arc spectrum as fiducial lines, which correspond with the following solar lines:—

## SOLAR LINES.‡

4191·595, Fe, 6.	4044·766, Fe, 3.
4187·204, Fe, 6.	4040·792, Fe, 3.
4175·806, Fe, 5.	4034·644, Mn-Fe, 6.
4171·068, Fe, 4.	4032·789, Fe, 4.
4143·572, Fe, 4.	4032·117, Fe, 2.

\* *Astrophysical Journal*, vol. i. 1895.

† Corrected by Rowland, and definitely assigned to aluminium. See the *Astrophysical Journal*, December, 1897.

‡ *Astrophysical Journal*, vol. i., February and March, 1895, and vol. vi., December, 1897.

The wave-lengths of the two gallium lines determined from these are as follows:—

Reversed lines, Plate iv.,	. . .	4172·214 and 4033·125.
Lines in Plate v.,	. . .	4172·214 and 4033·120.

With the stronger line the numbers vary between 4172·210 and 4172·216, and with the weaker line between 4033·117 and 4033·128.

The relative intensities of the two gallium lines are the same in the oxy-hydrogen flame, the arc (bright and reversed lines) and spark spectra; and they are fairly represented on Rowland's scale by 1 and 00.

We consider the wave-lengths determined from the reversed lines to be more accurate than those determined from the bright lines in Plate v. In the latter the gallium lines and closely adjacent iron lines overlap. We therefore adopt 4172·214 and 4033·125 as the wave-lengths of two lines in the spectrum of gallium which have been observed in various substances examined by us.

There are two lines, 4172·296, Fe, and 4033·224, Fe-Mn, which are so closely adjacent that we have not been able to distinctly separate them from the gallium lines, even when working on spectra of the second order, though the ends of the two lines can be observed with the microscope quite distinctly. By working in a clearer atmosphere, with a higher order of spectrum and a narrower slit, it may be possible to distinctly separate two Fraunhofer lines of these wave-lengths.

The evidence that gallium is contained in the sun is of the following character:—

1. This element, in minute proportions, is extraordinarily widely distributed in the crust of the earth, in felspar, mica, basalt, iron ores, and aluminous minerals generally. It is also commonly found, as we have ascertained, in pumice and volcanic dust from New Zealand and Krakatoa; thus proving its presence in the interior of the earth.

2. Gallium is a common constituent of iron meteorites, associated with nickel and cobalt.\*

3. The lines of gallium, both in the arc and spark spectra of a solution of gallium chloride, show that the less refrangible is the stronger line, and that their relative intensities are represented by 1 and 00 on Rowland's scale.

4. In the arc spectrum of gallium, these two lines are very easily reversed.

5. The wave-lengths of the gallium lines, 4172·214 and 4033·125, correspond with two lines in the solar spectrum, one of which has been assigned to aluminium by Rowland, the wave-lengths of which are 4172·211 and 4033·112.

As owing to the chemical properties of gallium oxide—its separation from alumina and other sesquioxide bases is extremely difficult, and requires a very

\* Scientific Proc. Roy. Dub. Soc., vol. viii. (N.S.), Part vi., p. 705.

special and peculiar treatment—we should expect to find that aluminous compounds, from whatever source, and aluminium would furnish the gallium lines, which is exactly in accordance with our experience. There can be no doubt, from the relative intensities of the lines, from their wave-lengths, from the association of gallium with aluminium and with iron, that the solar lines, 4172·211 and 4033·112, have their origin from gallium contained in the sun, which is present in small proportion when compared with iron, and that the solar spectrum, in so far as the proportion of gallium to iron is concerned, may be considered to be fairly imitated by the arc spectrum of blast-furnace iron containing  $\frac{1}{30000}$ th of its weight of gallium, since, if the more volatile metal were in any considerable proportion, the gallium lines would be broader and overlap those of iron with wave-lengths, 4172·296 and 4033·224.

This research brings to light the fact that, where coincidences are few in number, the mere coincidences of lines in the spectra of terrestrial matter with reversed lines in the solar spectrum is not equivalent to a proof of the existence of the elements in the sun or other heavenly bodies, even when the most powerful instruments are employed for resolving the lines. Professor Rowland's tables of solar spectrum wave-lengths show not only how nearly lines of different elements may coincide, but how there are some actual coincidences, as for instance of nickel, with iron lines. Lines may also overlap. Generally speaking, two lines of the same wave-length, belonging to different elements, differ in this respect, that one is strong, and the other weak, or perhaps not so strong.

Examples are familiar to us, and may be cited. For instance, two lines of rubidium are very frequently obscured by two of iron; the strong line of rubidium corresponds with the weak line of iron, and *vice versa*.\* If therefore the two lines appear of the same intensity, we know that rubidium is present; and if the order of their intensity is the reverse of that of the iron lines, we know then that the proportion of rubidium is larger than in the former case. Of course, the presence of iron is determined by other lines than these two which coincide with the rubidium lines. The greater mass of a substance may have the effect of obscuring or extinguishing some of the lines in the spectrum of another element less easily volatilised. On the other hand, the greater mass of a less easily vapourised substance may also obscure the lines of one more volatile which are in close proximity.

In conclusion, we tender our sincere thanks to Dr. Adeney for the aid so cordially given us in obtaining the photographs from which these measurements have been made.

\* Wave-lengths of the rubidium lines, 4215·72 and 4201·98.; wave-lengths of the iron lines, 4216·28 and 4202·15.

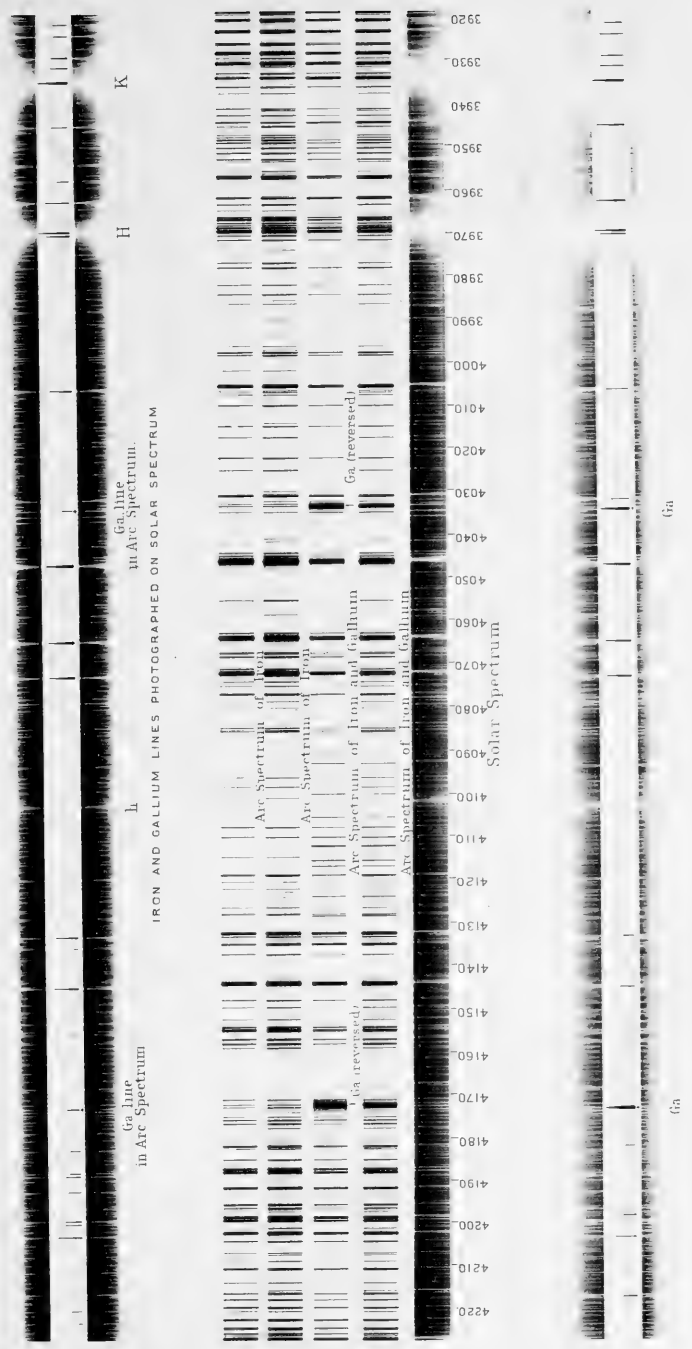

IRON AND GALLIUM LINES PHOTOGRAPHED ON SOLAR SPECTRUM

IRON AND GALLIUM LINES PHOTOGRAPHED ON SOLAR SPECTRUM







## TRANSACTIONS (SERIES II.).

---

VOL. I.—Parts 1–25.—November, 1877, to September, 1883.

VOL. II.—Parts 1–2.—August, 1879, to April, 1882.

VOL. III.—Parts 1–14.—September, 1883, to November, 1887.

VOL. IV.—Parts 1–14.—April, 1888, to November, 1892.

VOL. V.—Parts 1–13.—May, 1893, to July, 1896.

VOL. VI.—Parts 1–16.—February, 1896, to August, 1898.

---

## VOLUME VII.

### PART

1. A Determination of the Wave-lengths of the Principal Lines in the Spectrum of Gallium, showing their Identity with Two Lines in the Solar Spectrum. By W. N. HARTLEY, F.R.S., and HUGH RAMAGE, A.R.C.S.C.I. Plate I. (August, 1898.) 1s.

[JUNE, 1899.]

THE

SCIENTIFIC TRANSACTIONS

OF THE

ROYAL DUBLIN SOCIETY.

VOLUME VII.—(SERIES II.)

---

II.

RADIATING PHENOMENA IN A STRONG MAGNETIC FIELD. PART II.—  
MAGNETIC PERTURBATIONS OF THE SPECTRAL LINES. BY THOMAS  
PRESTON, M.A., D.Sc., F.R.S.

---

DUBLIN:

PUBLISHED BY THE ROYAL DUBLIN SOCIETY.

WILLIAMS AND NORGATE,

14, HENRIETTA STREET, COVENT GARDEN, LONDON;

20, SOUTH FREDERICK STREET, EDINBURGH; AND 7, BROAD STREET, OXFORD.

PRINTED AT THE UNIVERSITY PRESS, BY PONSONBY AND WELDRICK.

1899.

---

*Price One Shilling.*



## INDEX SLIP.

PRESTON, THOMAS.—Radiating Phenomena in a strong Magnetic Field. Part II.—  
Magnetic Perturbations of the Spectral Lines.  
Roy. Dublin Soc. Trans., s. 2, vol. 7, 1899, pp. 7-22.

Magnetic Perturbations of the Spectral Lines.  
Preston, Thomas.  
Roy. Dublin Soc. Trans., s. 2, vol. 7, 1899, pp. 7-22.

Spectral Lines, Magnetic Perturbations of the.  
Preston, Thomas.  
Roy. Dublin Soc. Trans., s. 2, vol. 7, 1899, pp. 7-22.

17

1800

1800

1800

[JUNE, 1899.]

THE

SCIENTIFIC TRANSACTIONS

OF THE

ROYAL DUBLIN SOCIETY.

VOLUME VII.—(SERIES II.)

---

II.

RADIATING PHENOMENA IN A STRONG MAGNETIC FIELD. PART II.—  
MAGNETIC PERTURBATIONS OF THE SPECTRAL LINES. BY THOMAS  
PRESTON, M.A., D.Sc., F.R.S.

---

DUBLIN:  
PUBLISHED BY THE ROYAL DUBLIN SOCIETY.  
WILLIAMS AND NORGATE,  
14, HENRIETTA STREET, COVENT GARDEN, LONDON:  
20, SOUTH FREDERICK STREET, EDINBURGH; AND 7, BROAD STREET, OXFORD.  
PRINTED AT THE UNIVERSITY PRESS, BY PONSONBY AND WELDRICK.

1899.





## II.

RADIATING PHENOMENA IN A STRONG MAGNETIC FIELD. PART II.—MAGNETIC PERTURBATIONS OF THE SPECTRAL LINES. BY THOMAS PRESTON, M.A., D. Sc., F.R.S.

[Read JANUARY 18, 1899.]

IN December, 1897, I laid before this Society an account of some experiments and observations which I had previously made while investigating the modifications which the radiations from a source of light suffers when the source is placed in a strong magnetic field.\* Briefly stated, the results then obtained showed that the majority of the spectral lines behaved according to the expectations of theory, and became resolved into triplets when viewed across the lines of force; but, on the other hand, many lines deviated from this law, and became resolved into quartets, sextets, or other forms, under exactly the same conditions.

In order to explain the existence of these deviations from the ordinary triplet type, it was suggested that they might be due to reversals in the cooler layers of vapour surrounding the source of light; but it was also pointed out that the appearance of these modified forms did not by any means favour that explanation, and, in addition, it was mentioned that deviations from the triplet type ought to be expected, for the conditions necessary to produce pure tripling could not be expected to hold good in all cases.

It was consequently a matter of some importance to determine whether these more complex forms are really due to the action of the magnetic field on the vibrating ions, or to some extraneous cause, such as absorption. I accordingly tried sparking with weak solution, so as to diminish all chance of reversal, but in no case did the quartets or other modifications reduce to the triplet form. On the contrary, they became clearer and more precise as the lines became sharper with the reduced quantity of vapour. Nevertheless this was not regarded as seriously in opposition to the supposition of reversal, for the appearance of reversed lines in a strong magnetic field, where the spark is blown about, might differ from that of ordinary reversals. I then tried to further increase the strength of the

\* See Trans. R. D. S., vol. vi., p. 385, 1898.

magnetic field, and determine if the components of the supposed reversed line remained at the same distance apart, or became more widely separated as the strength of the field increased.

The extent to which I was able to increase the strength of the field at that time was not sufficient, however, to enable me to determine with certainty whether the reversal hypothesis was absolutely untenable or not. For although the components of the supposed reversed line appeared to separate continuously with increase of the magnetic field, yet this separation was not sufficiently great to overthrow the reversal hypothesis, for it might be said that the wider gap between the lines was due to the absorption-band being merely a little wider. The weight of evidence, however, appeared to be against the reversal theory; and, in order to push this test to a definite conclusion, I had a powerful electromagnet of special design built, which, it was hoped, would give a field sufficiently strong to determine matters decisively. I am happy to be able to state that this magnet has in every way acted up to expectation; and, thanks to the courtesy of the University authorities and of the Curator, Dr. W. E. Adeney,\* I was able to resume work at the Royal University with the improved apparatus; and it was soon found that the reversal theory must be abandoned, and that the explanation of the quartets and other deviations from the normal triplet type must be sought for in other agencies.

Before proceeding to the description of these more recent results, we shall refer for a moment to figs. 1 and 2, in order that the explanation which follows may be more easily intelligible. In fig. 1, the three lines *A*, *B*, *C*, are supposed to represent a triplet of the normal type, into which the majority of spectral lines becomes resolved by the action of the magnetic field when the light is viewed across the lines of force. The vibrations in *B* and *C* are parallel to their length, while the vibrations in *A* are in the perpendicular direction. In the same way, fig. 2 represents a quartet produced by the magnetic field, or, if we may say so, a triplet in which the middle line *A* has become converted, by some cause or other, into a doublet. The lines *B* and *C*, as before, have their vibrations parallel to their length, while the pair of lines *A* have their vibrations in the perpendicular direction. We may, therefore, refer to the *B* and *C* as the sides, and to *A* as the middle, of the resolved line, even when *B* and *C* are complex as well as *A*: for *B* and *C*, in some cases, are also resolved into doublets or triplets, but they are always distinguished from *A* by the fact that their plane of polarization is perpendicular to that of *A*. Thus, in general, each of the members, *A*, *B*, *C*, of the triplet, fig. 1, may become

\* Throughout this and the previous investigations I am deeply indebted to Dr. Adeney, for he kindly invited me to the Royal University laboratories, and facilitated my work under conditions which necessarily interfered with his own researches.

resolved into a doublet or a triplet; or  $A$  may be a doublet, while  $B$  and  $C$  are, or are not, further resolved. It may even happen that the constituents of  $A$  become, in some cases, more widely separated from each other than  $B$  is from  $C$ , so that the centre  $A$  of the triplet, as it were, contains the sides within it, and thus we become prepared to consider the case, if any such exists, in which  $B$  and  $C$  are not appreciably separated, or coincide, while the components of  $A$  are at a considerable distance apart.

In order to examine  $A$  separately from  $B$  and  $C$ , advantage may be taken of the fact, that the plane of polarization of  $A$  is perpendicular to that of  $B$

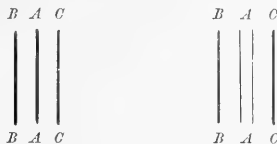

FIG. 1.—NORMAL TRIPLET.

FIG. 2.—QUARTET.

and  $C$ , so that if a Nicol's prism be properly interposed,  $B$  and  $C$  can be extinguished, while  $A$  remains alone in the field of view, or  $A$  may be extinguished while  $B$  and  $C$  remain in the field of view. Instead of using a Nicol's prism, however, it is better to employ a double-image prism—such, for example, as a Wollaston's prism made of quartz. With this piece of apparatus, properly placed before the slit of the spectroscope, two images of the source may be cast upon the slit, one above the other, and completely separated, or overlapping to some extent, as may be desired. One of these images contains the light



FIG. 3.

FIG. 4.

(Showing effect of double-image prism.)

vibrating parallel to the lines of force ( $A$ ), while the other contains the light vibrating in the perpendicular direction ( $B$  and  $C$ ). These two images produce two parallel spectra, one above the other, in the field of view, one of which contains all the middles ( $A$ ) of the lines as modified by the magnetic field, while the other contains all the sides ( $B$  and  $C$ ). As a consequence, the appearance presented in the field of view is somewhat like that shown in figs. 3 and 4, in

which fig. 3 corresponds to fig. 1, and fig. 4 to fig. 2. The action of the double image prism is thus to separate the middle from the side constituents, while, at the same time, it possesses the advantage of showing all the constituents simultaneously,\* and shows each of them unblurred by overlapping with the others.

The question now before us is, can the quartet shown in fig. 2 be derived from the triplet of fig. 1 by reversal of the central line *A*, or does the doubling of *A* depend upon other causes?

In answer to this question, as has been already remarked, the appearance of the doublet *A* is against the reversal hypothesis, and it is further established beyond all doubt, by means of my improved magnetic field, that the distance between the components of *A* increases proportionately to the strength of the field just as the distance between the side lines *B* and *C* increases with the strength of the field. Further, when *B* and *C* are each a doublet or a triplet, the distance between the members of each of these doublets or triplets increases with the strength of the field in the same direct ratio. In fact, as the strength of the field increases, the system of lines which constitute *A*, *B*, and *C* separate laterally according to a uniform scale; and, in face of these facts, the reversal hypothesis becomes quite untenable.

The general phenomenon, therefore, which remains to be explained is the resolution of each member of the normal triplet (fig. 1) into a doublet or a triplet or some other system; and, as we shall see immediately, the electromagnetic theory proposed by Dr. Larmor † may be extended to embrace all the phenomena yet observed. Before proceeding to consider this explanation, however, it may be well to refer briefly to a particular type of modification which was recently announced as having been observed by MM. Becquerel and Deslandres, ‡ and subsequently by Messrs. J. S. Ames, R. F. Earhart, and H. M. Reese. § This particular type is referred to by them as an example of "reversed polarization," that is a case in which the modified line shows as a triplet in the magnetic field, but in which the vibrations in the centre line *A* are parallel to the lines of force while the vibrations in *B* and *C* are perpendicular to the lines of force—the reverse of the normal case. Stated in this way, the phenomenon is very startling, and seems, at first sight, quite contradictory to all theoretical expectations. But if we return to fig. 4, and take into consideration the remarks already made, viz. that the components of *A* may be widely

\* This device was employed independently by the author and MM. Becquerel and Deslandres. A double-image prism was also used, in a different way by M. Cornu.

† Dr. J. Larmor, *Phil. Mag.*, vol. xlv., p. 505, 1897.

‡ *Comptes Rendus*, t. 126, p. 997, April, 1898.

§ *Astrophysical Journal*, vol. viii., p. 48, June, 1898.

separated, while  $B$  and  $C$  are not sensibly separated, or coincide, we see that the case cited by the French and American authors, if it exists, presents no further difficulty, being merely an extreme case of the ordinary quartet form shown in fig. 4. Thus, in fig. 5 we have a quartet in which the separation of the central part  $A$  is nearly as great as that of the side lines  $B$  and  $C$ , while in fig. 6 the case is shown in which the separation of the components of  $A$  exceeds that of the side lines  $B$  and  $C$ ; and, in fig. 7, the extreme case is shown in which  $B$  and  $C$  coincide, or are not visibly separated, while  $A$  is divided into two widely-separated parts. This, then, is the so-called "reversed polarization" type, which, if it exists, forms merely the end link in a continuous chain, and offers no special theoretical difficulties. Once the ordinary quartet is explained, all the foregoing forms become explained, and follow in sequence as expected variations. For the cause which converts  $A$  into a doublet may be sufficiently active to separate



FIG. 5.



FIG. 6.



FIG. 7 (not observed?).

the constituents of  $A$  by an amount which may be either greater or less than the separation of the side lines  $B$  and  $C$ .

But it is very doubtful if the extreme type (fig. 7) has yet been observed; for although the present writer made an early study of the spectrum of iron, which is the spectrum in which some of the lines are said to show the so-called phenomenon of "reversed polarization," yet in no case has he been able to detect the peculiarity described above. In fact, as I have stated elsewhere,\* the spectrum of iron presents no specially new types of effect, and on my photographic plates the lines referred to by the French and American observers as showing reversed polarization do not show  $B$  and  $C$  as coincident lines, but show  $B$  and  $C$  as two broad, weak lines overlapping at their inner edges, so that a dark rib runs down the centre, giving  $BC$  the appearance of a dark central line (on the negative) winged by two broader and fainter bands. It is thus likely that these lines are really quartets in which  $A$  is a doublet and  $B$  and  $C$  are broad and

\* Proc. Roy. Soc., January, 1898. The doublets referred to in this paper turned out, on further resolution, to be quartets.

not resolved clear of each other, but until this resolution is effected it remains possible that  $B$ ,  $C$  may be a triplet. These lines are all in the ultra-violet part of the spectrum, and are weak, so that a prolonged exposure is necessary to bring out all the details. When the double-image prism is not employed they photograph as triplets, or rather as bands possessing three dense ribs; but this arises from the components of  $A$  overlapping the outer edges of  $B$  and  $C$ , while  $B$  and  $C$  overlap each other a little, and thus form the middle rib of the triplet.

It appears, therefore, that if we can explain the production of the ordinary quartet form (fig. 2) we are on the high road to the explanation of all the other types of modification which the spectral lines suffer in the magnetic field. For this purpose, therefore, let us consider briefly the investigation set forth in Dr. Larmor's paper, already cited. In this investigation he considers the case of a single ion describing an elliptic orbit under a central force directly proportional to the distance. The influence of the magnetic field upon this moving ion (supposed otherwise quite free from restraints) is such that its elliptic orbit is forced into precession round a line drawn through its centre in the direction of the lines of magnetic force. For the equations of motion of the ion moving round the centre of force in the magnetic field are, as a first approximation, the same as those which hold for a particle describing an elliptic orbit under a central force when the orbit is forced to precess or revolve round a line drawn through its centre in the direction of the lines of force. Thus the equations which determine the motions of the ion are—

$$\left. \begin{aligned} \ddot{x} &= -\Omega^2 x + k(n\dot{y} - m\dot{z}) \\ \ddot{y} &= -\Omega^2 y + k(l\dot{z} - n\dot{x}) \\ \ddot{z} &= -\Omega^2 z + k(m\dot{x} - l\dot{y}) \end{aligned} \right\} \dots (1),$$

where  $k$  is a quantity depending on the strength of the field, and the ratio of the ionic charge to the inertia associated with it. While the equations of motion of a particle describing an elliptic orbit under a central force while the orbit is forced to precess with angular velocity  $\omega$  round a line whose direction cosines are  $l$ ,  $m$ ,  $n$  are easily found by taking as axes of reference a system of moving axes which revolve round  $l$ ,  $m$ ,  $n$  with angular velocity  $\omega$ , and are—

$$\left. \begin{aligned} \ddot{x} &= -\Omega^2 x + 2\omega(n\dot{y} - m\dot{z}) + \omega^2 x - \omega^2 l(lx + my + nz) \\ \ddot{y} &= -\Omega^2 y + 2\omega(l\dot{z} - n\dot{x}) + \omega^2 y - \omega^2 m(lx + my + nz) \\ \ddot{z} &= -\Omega^2 z + 2\omega(m\dot{x} - l\dot{y}) + \omega^2 z - \omega^2 n(lx + my + nz) \end{aligned} \right\} \dots (2),$$

and these agree with equations (1), when  $\omega^2$  is small enough to be neglected, and if  $2\omega$  be taken equal to  $k$ .

If  $N$  be the frequency of revolution of the ion in its orbit, and if  $n$  be the frequency of the precessional revolution, then the combined movement is

equivalent to three coexisting motions of frequencies  $N + n$ ,  $N$ , and  $N - n$ , respectively, and consequently a spectral line of frequency  $N$  becomes resolved into a triplet of frequencies  $N + n$ ,  $N$ , and  $N - n$ . This simple theory, therefore, predicts that a single spectral line should become a triplet in the magnetic field, and (since the magnetic force is fixed in direction) that the constituents of the triplet should be plane polarised when viewed across the lines of force. It teaches us that the cause of the tripling is the forced precession of the ionic orbits round the lines of magnetic force, and it assigns a dynamical cause for this precession in the action of the magnetic field on the ionic charge moving through it.

But this simple precessional perturbation of the orbit is obtained on the supposition that the ion is otherwise free from all constraint, or that its freedom is the same in all directions, in the magnetic field. If other constraints come into play on some of the ions, that is, if equal freedom in all directions does not exist, then other perturbations of the ionic orbits must exist, and the spectral lines which are produced by these will show deviations from the normal triplet type when subject to the magnetic field. And, as it is hardly to be expected that perfect freedom from other perturbations should exist, we ought not to be surprised that modifications, other than the normal triplets, are presented when the subject is examined experimentally. Thus, if, besides having the precessional motion, the orbit be forced into an apsidal motion, or a motion of revolution in its own plane, then each member of the precessional triplet will become a doublet, and the normal triplet will become a sextet; such, for example, as that presented by the line  $D_2$  of sodium. Again, if the inclination of the plane of the orbit to the line round which precession takes place be subject to periodic variations, or if it have another precessional motion round another axis, then each member of the precessional triplet will itself be a triplet, and so on for other types of perturbations.

It is, however, unnecessary to enter into detail here concerning these and other similar matters, as they have already been treated very fully by Dr. Stoney\* in the Transactions of this Society, and, indeed, published several years before the facts here requiring explanation were discovered. Dr. Stoney's object was to explain the existence of doublets and equidistant satellites in the spectra of gases, that is in the natural spectra unaffected by the magnetic field—for at that time the influence of the magnetic field was not known to exist. Thus the character of certain spectra indicated that the lines resolved themselves naturally into certain groups, or series of groups. For example, in the case of the monad elements Na, K, &c., the spectrum resolves itself into three series of

\* Dr. G. J. Stoney, Trans. Roy. Dub. Soc., vol. iv., p. 563, 1891—"On the Cause of Double Lines and Equidistant Satellites in the Spectra of Gases."

pairs of lines, like the great *D* pair of sodium, and Dr. Stoney's object was to explain these pairs of lines. In the first place, he showed that if the disturbing forces exist which cause the orbit to revolve in its own plane, that is produce an apsidal motion, then each spectral line will become a pair of lines, and if  $N$  be the frequency of the original line, that is the frequency of revolution of the ion in its orbit, and  $n$  the frequency of the apsidal revolution, then the frequencies of the new pairs will be  $N + n$  and  $N - n$ . This is very easily deduced by Dr. Stoney from the expressions for the coordinates of the moving ion at any time  $t$ . Thus, if a particle describes an elliptic orbit under a central force (law of direct distance) directed towards its centre, its coordinates at any instant may be written in the form

$$x = a \cos \Omega t, \quad y = b \sin \Omega t,$$

in which  $\Omega$  is equal to  $2\pi N$  where  $N$  is the frequency of revolution. But if, in addition, the orbit be forced to revolve round its own centre in its own plane with angular velocity  $\omega$ , then it is easily seen by projection that the coordinates at any time are—

$$\begin{aligned} x &= a \cos \Omega t \cos \omega t - b \sin \Omega t \sin \omega t, \\ y &= a \cos \Omega t \sin \omega t + b \sin \Omega t \cos \omega t; \end{aligned}$$

and these are equivalent to

$$\begin{aligned} x &= \frac{1}{2}(a + b) \cos (\Omega + \omega) t + \frac{1}{2}(a - b) \cos (\Omega - \omega) t, \\ y &= \frac{1}{2}(a + b) \sin (\Omega + \omega) t - \frac{1}{2}(a - b) \sin (\Omega - \omega) t, \end{aligned}$$

while these in turn are equivalent to the two opposite circular vibrations

$$\left. \begin{aligned} x_1 &= \frac{1}{2}(a + b) \cos (\Omega + \omega) t \\ y_1 &= \frac{1}{2}(a + b) \sin (\Omega + \omega) t \end{aligned} \right\} \quad \left. \begin{aligned} x_2 &= \frac{1}{2}(a - b) \cos (\Omega - \omega) t \\ y_2 &= -\frac{1}{2}(a - b) \sin (\Omega - \omega) t \end{aligned} \right\}.$$

The resultant motion is consequently equivalent to two circular motions described in opposite senses, and of frequencies  $N + n$  and  $N - n$  respectively. These circular motions will be polarised when the perturbing forces remain fixed in direction, and for this reason the doublets, &c., produced by the magnetic field are polarised. On the other hand, the doublets, &c., existing in natural spectra are not polarised, and this is what we should expect when we consider the effects of collisions.

This is an analysis of the motion without any regard to the dynamical origin of it. It is merely postulated that certain perturbations exist, and their effects on the pure radiation frequencies are examined. If, however, we treat the question from a dynamical point of view, the equations of motion will exhibit the forces which are necessary to bring about the supposed motion. Thus, if a



particle is attracted to a fixed centre with an acceleration  $\Omega^2 r$ , while its orbit revolves in its own plane with angular velocity  $\omega$ , then, by taking the moving axes of the orbit as axes of reference, the equations of motion become—

$$\left. \begin{aligned} \ddot{x} &= -\Omega^2 x + \omega^2 x + 2\omega \dot{y} \\ \ddot{y} &= -\Omega^2 y + \omega^2 y - 2\omega \dot{x} \end{aligned} \right\} \dots \dots (3).$$

So that, if  $(x, y) = e^{ipt}$  be a solution, we have at once—

$$p = \Omega \pm \omega,$$

which shows at once the doubly periodic character of the motion, and also exhibits the character of the perturbing forces necessary to produce the given apsidal motion of the orbit. For if the orbit were fixed, the equations of motion would be  $(\ddot{x}, \ddot{y}) = -A^2(x, y)$ ; hence the remaining terms on the right hand side of (3) must represent the perturbing forces. Of these the final terms  $2\omega \dot{y}$  and  $-2\omega \dot{x}$  are the  $x$  and  $y$  components of a force  $2\omega v$  (where  $v$  is the velocity of the particle) acting in the plane of the orbit and along the normal to the path of the particle. This represents the force which a charged particle or an ion experiences in traversing a magnetic field when the lines of force are perpendicular to the plane of the orbit, if  $2\omega$  be taken equal to the quantity  $k$  in equations (2). The other pair of terms  $\omega^2 x$  and  $\omega^2 y$  represent a centrifugal force arising from the imposed rotation  $\omega$ . If we neglect  $\omega^2$ , the equations (3) become identical in form with equations (1), and when  $\omega^2$  is not negligible they are identical in form with equations (2), for the values  $(l, m, n) = (0, 0, 1)$ , as they obviously should, for an apsidal motion of an orbit in its own plane is the same thing as a precessional motion of the orbit round an axis perpendicular to its plane. In this case the motion has no component in the direction of the axis round which precession takes place, and consequently the frequencies  $N + n$  and  $N - n$  alone exist, so that the central line of the precessional triplet is absent, and a doublet alone is produced.

In the same way, if we work backwards from the general equations (2) of uniform precessional motion, we see that the perturbing forces consist, firstly, of a force  $2\omega v \sin \theta$ ; where  $v$  is the velocity of the particle and  $\theta$  the angle its direction of motion makes with the axis round which the precession  $\omega$  takes place. This force, which is represented by the terms in  $\dot{x}, \dot{y}, \dot{z}$  of equations (2), acts along the normal to the plane of  $\omega$  and  $v$  (the axis of rotation and the direction of the velocity), and is precisely the force experienced by an unconstrained ion moving in a magnetic field. The remaining terms in  $\omega^2$  are clearly the components of a centrifugal force arising from the rotation round the axis  $(l, m, n)$ ; and this is negligible only when  $\omega$  is relatively small.

## EXPLANATION OF THE QUARTET AND OTHER FORMS.

If the direction  $l, m, n$  be taken to be that of the lines of magnetic force, and if the axis of  $z$  be taken to coincide with this direction, then the equations (2) simplify into

$$\left. \begin{aligned} \ddot{x} &= -(\Omega^2 - \omega^2)x + 2\omega\dot{y} \\ \ddot{y} &= -(\Omega^2 - \omega^2)y - 2\omega\dot{x} \\ \ddot{z} &= -\Omega^2z \end{aligned} \right\} \dots (4),$$

and these are the equations of motion of a particle describing an elliptic orbit which precesses with angular velocity  $\omega$  round the axis of  $z$ . The two first of these equations contain  $x$  and  $y$ , and give the projection of the orbit on the plane  $x, y$  at right angles to the axis of the magnetic field. This projection is an ellipse revolving on its own plane, with an apsidal angular velocity  $\omega$ , and gives rise to the two side lines of the normal triplet of frequencies  $(\Omega \pm \omega)/2\pi$ . On the other hand, the vibration parallel to the axis of  $z$  is unaffected by the precessional motion, and gives rise to the central line of the triplet of frequency  $\Omega/\pi$ .

Now, in order to account for the quartet (fig. 2), we must introduce some action which will double the central line  $A$  while the side lines  $B$  and  $C$  are left undisturbed. That is, we want to introduce a double period into the last of equations (4) while the first and second remain unchanged. This is easily done if we write the equation for  $z$  in the form

$$z = A \sin \Omega t \dots (5),$$

and remark that this will represent two superposed vibrations of different periods if we regard  $A$  as a periodic function of the time instead of a constant. That is, if we take  $A$  to be of the form  $a \sin nt$ , we will have\*

$$z = a \sin nt \sin \Omega t = \frac{a}{2} [\cos (\Omega - n) t - \cos (\Omega + n) t],$$

which represents two vibrations of equal amplitude and of frequencies  $(\Omega - n)/2\pi$  and  $(\Omega + n)/2\pi$  as required to produce the quartet. The magnitude of  $n$  determines whether the separation of the constituents of the central line  $A$  (fig. 2) shall be less than, or greater than, the separation of the side lines  $B$  and  $C$ ; and if the former is sensible while the latter is insensible, we are presented with the

\* If  $A$  be taken of the form  $(a + b \sin nt)$  the central line will be a triplet of frequencies  $N+n, N, N-n$ , and by a similar supposition regarding the perturbing forces, the side lines may become replaced by doublets or triplets. Such doublets and triplets exist, and the amplitudes of their constituents are determined by the quantities  $a$  and  $b$ .

case depicted in fig. 7, although, as I have said before, my observations do not confirm the existence of this case.

The supposition made above to account for the doubling of the middle line, viz. that the amplitude of the  $z$  component vibration varies periodically, is one which appears to be justified when we consider the nature of the moving system and the forces which control it. For the revolving ion is part of some more or less complex system which must set in some definite way under the action of the magnetic field—say with its axis along the direction of the magnetic force—and, in coming into their position, the inertia of the system will cause it to vibrate with small oscillations about the position of equilibrium, and this vibration superposed on the precessional motion of the ionic orbit gives the motion postulated above to explain the quartet.

This, indeed, comes to the same thing, as a suggestion made by Prof. G. F. FitzGerald about a year ago—shortly after I discovered the existence of the quartet form (October, 1897). In Prof. FitzGerald's view, the ion revolving in its orbit is equivalent to an electric current round the orbit, and therefore the revolving ion and the matter with which it is associated behaves as a little magnet, having its axis perpendicular to the plane of the orbit. The action of the magnetic field will be to set the axis of this magnet along the lines of force, and, in taking up this set, the ionic orbit will vibrate about its position of equilibrium, just as an ordinary magnet vibrates about its position of rest under the Earth's magnetic force.

In a similar way a periodic change in the ellipticity of the orbit produces a doubling of the spectral lines previously existing, while a periodic oscillation in the apsidal motion renders the lines nebulous or diffuse; and by treating these cases in the foregoing manner the corresponding forces may be discovered.

It is clear, therefore, that perturbations of this kind are sufficient to account for all the observed phenomena, and that the theory is ready to meet the demands of more complicated types than have yet been observed. It is legitimate to expect that perturbations of this kind will occur in some, at least, of the ionic motions, and, in fact, that they must occur, and that the perfect freedom required for the production of the pure precessional triplet cannot exist in all cases.

The existence of all these variations of the normal triplet is a matter of great interest, not only as showing that the perfect uniformity required for the production of the normal triplet is not maintained in all cases, but also as giving us a further insight into the nature of the conditions under which the ionic motions take place, as well as demonstrating that the causes supposed by Dr. Stoney, in 1881, to be operative in producing doublets and satellites in the natural spectra of gases may be really the true causes by which they are produced.

Nevertheless, Dr. Stoney's explanation of the natural doublets is opposed by a serious difficulty in the fact that the two lines of a given doublet, say the two  $D$  lines of sodium, behave in different ways, as if they arose from different sources rather than from the perturbation of the same source. For, in addition to the differences previously known to exist, there is the difference of behaviour in the magnetic field. Thus,  $D_1$  is a wide-middled quartet, in which the distance between the central lines  $A$  (fig. 5) is nearly as great as the distance between the side lines  $B$  and  $C$ , while  $D_2$  shows as a sextet of uniformly-spaced lines.

In a similar manner individual members of the natural triplets which occur in the natural spectra of the zinc, cadmium, magnesium, &c., groups, behave differently. Thus, if we denote the numbers of one of the natural triplets by the symbols  $T_1$ ,  $T_2$ ,  $T_3$  in ascending order of refrangibility (for example, the triplet 5086, 4800, 4678 of cadmium, or the triplet 4811, 4722, 4680 of zinc, or the green  $b$  triplet of magnesium), we find that  $T_3$  in all cases, in the magnetic field, shows as a pure triplet, or suffers, according to the foregoing, merely precessional perturbation. On the other hand,  $T_2$  shows in each case as a quartet, while  $T_1$  is a more or less diffuse triplet, in which each of the members may prove to be complex on further resolution.\* This would seem to point to an essential difference in the characters of the lines  $T_1$ ,  $T_2$ ,  $T_3$ , as if they sprang from different origins rather than immediately from the same origin.

#### DIFFERENT CLASSES OF NATURAL GROUPS.

It is also of great interest to note that, so far as my observations yet show, the natural groups into which the spectral lines arrange themselves show, as

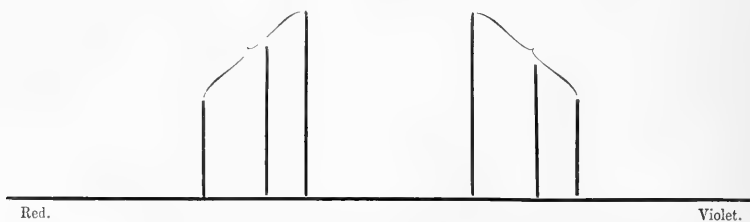

FIG. 8.—TRIPLLET OF SECOND SERIES. FIG. 9.—TRIPLLET OF FIRST SERIES.  
[The ordinates represent the separations  $\delta\lambda$  of the side lines by the same magnetic field.]

groups, a characteristic difference in their behaviour in the magnetic field. Thus, if we take the case of the natural triplets in the spectrum of zinc, we find that these triplets arrange themselves into two series (the first and second

\* See Addendum, p. 21.

subsidiary series of Kayser and Runge), and when the action of the magnetic field is recorded, it is found that the magnetic effect increases with the refrangibility for the members of a triplet of the second series (fig. 8), whereas the reverse is the case for a triplet of the first series (fig. 9). Examples of the former class occur in the natural triplets of cadmium, zinc, and magnesium, already mentioned; and further examples of these and other peculiarities I hope to give in the near future, as soon as I have fully examined and verified them.

#### GENERAL LAW.

The first general survey of the magnetic effect on the spectral lines of any given substance did not appear to favour the view that the phenomena are subject to any simple law. According to the electro-magnetic theory the separation  $\delta\lambda$ , of the side lines of a magnetic triplet, should, under the same conditions, vary directly as  $\lambda^2$ , as we pass from line to line of the same spectrum. The possibility of such a law as this seemed to be refuted by the fact that some lines are largely affected in the magnetic field, while others, of nearly the same wave-length in the same spectrum, are not appreciably affected under the same circumstances. In this connexion, however, I pointed out\* that "it is possible that the lines of any one substance may be thrown into groups for each of which  $\delta\lambda$  varies as  $\lambda^2$ , and each of these groups might be produced by the motion of a single ion. The number of such groups in a given spectrum would then determine the number of different kinds of ions in the atom or molecule.

"Homologous relations may also exist between the groups of different spectra, but all this remains for complete investigation."

Although the investigation referred to in the foregoing is still far from complete, yet the measurements so far made uniformly tend to confirm the above speculation. For the corresponding lines of the natural groups into which a given spectrum resolves itself possess the same value of  $e/m$  or  $\delta\lambda/\lambda^2$ ; and further, this value is the same for corresponding lines in homologous spectra of different substances.

To illustrate the meaning of this, take the case of magnesium, cadmium, and zinc, which are substances possessing homologous spectra, and belonging to the same chemical group (Mendeleeff's second group). The spectra of these metals consist of a series of natural triplets. The first triplet of the series in magnesium is the green *b* group, consisting of the wave-lengths 5183·8, 5172·8, 5167·5, while the first cadmium triplet consist of the lines 5086, 4800, 4678, and the first zinc triplet consists of the lines 4810·7, 4722, 4680. Each of these triplets

\* *Phil. Mag.*, April, 1898, p. 337.

belongs to Kayser and Runge's second subsidiary series, being the first terms, corresponding to  $n = 3$ , in their formula. We should, consequently, expect these groups to behave similarly in the magnetic field, and to show effects which are similar for corresponding lines. That this expectation is realized is shown by the following Table:—

Magnesium.	Cadmium.	Zinc.	$m/e$ or $\lambda^2/\beta\lambda$ .	Character.
5183·8	5086	4810·7	18 approx.	Complex triplets.
5172·8	4800	4722	11·5 ,,	Quartets (Sextets).
5167·5	4678	4680	10 ,,	Pure triplets.

Thus the corresponding lines 5183·8, 5086, and 4810·7 of the different substances possess the same value for  $m/e$ , while the other corresponding lines also possess a common value for the quantity  $m/e$ . The value of this quantity changes from one set of lines to another, showing, as we should expect, that the different sets arise from differences in the source which produces them.

Not only is the quantity  $m/e$  the same for corresponding lines in the same and in homologous spectra, but, as shown in the above Table, the *character* of the magnetic effect is also the same for corresponding lines. Thus, while the lines along the lowest row, 5167, 4678, 4680 are all of the pure triplet type, the lines of the middle row all become resolved into similar quartets in the magnetic field, and the lines forming the top row are all somewhat diffuse, and show as "soft" triplets, of which the constituents may be really complex on further resolution.

It thus appears that the observation of the radiating phenomena in the magnetic field is likely to afford a valuable means of inquiry into the so far hidden nature of the events which bring about the radiation from a luminous body, and also give us, perhaps, some clearer insight into the structure of matter itself.

## ADDENDUM.

Since the foregoing was written I have examined several spectral lines in a magnetic field of which the strength could be gradually increased up to a value considerably exceeding 40,000 C. G. S. units. In this very intense field I had hopes that some further resolution of the spectral lines might be observed, and in this hope I have not been disappointed. For example, the quartet form, such as the lines 5172·8 Mg, 4800 Cd, and 4722 Zn, becomes distinctly resolved into a sextet, the resolution taking place by the splitting up of each of the side lines into a doublet. This is shown in figs. 10 and 11, of which fig. 10 shows the



FIG. 10.



FIG. 11.

magnetic effect as presented to the eye by a field of, say, 20,000 C. G. S. units, whereas fig. 11 shows the further resolution produced by a field of strength approaching 40,000 units. It thus appears that the quartet form as heretofore noticed is really a sextet in which the separation of the components of the side lines is considerably less than that of the components of the middle line.

Even in this intense field the normal, or pure, triplets of the type 5167·5 Mg, &c., remain firm, and do not split up further, or, at least, the evidence of further splitting up is too slight to enable one to state that any positive indication in that direction exists.

In the case of the complex, or diffuse, triplets of the type 5183·8 Mg, 5086 Cd, 4810·7 Zn the character of the resolution become quite cleared up. For what was in the weaker fields merely a diffuse or nebulous triplet is now shown to be a triplet in which each constituent consists of three fine lines. These lines are not of the sharp, steady character possessed by those of the normal triplet, but are of an unsteady, flickering character, and are backed by a good deal of hazy nebulous light. Further, the component nine lines are not equally bright, except in the case of the central three, which are fine and equally spaced. The triplets which form the wings, however, have their outer components

very weak and their inner components very strong, as indicated roughly in fig. 12.



FIG. 12.

This, therefore, is further important information on the similarity, or identity, of the machinery in different substances which originates the corresponding lines in their spectra.





## TRANSACTIONS (SERIES II.).

---

VOL. I.—Parts 1-25.—November, 1877, to September, 1883.

VOL. II.—Parts 1-2.—August, 1879, to April, 1882.

VOL. III.—Parts 1-14.—September, 1883, to November, 1887.

VOL. IV.—Parts 1-14.—April, 1888, to November, 1892.

VOL. V.—Parts 1-13.—May, 1893, to July, 1896.

VOL. VI.—Parts 1-16.—February, 1896, to August, 1898.

---

## VOLUME VII.

PART

1. A Determination of the Wave-lengths of the Principal Lines in the Spectrum of Gallium, showing their Identity with Two Lines in the Solar Spectrum. By W. N. HARTLEY, F.R.S., and HUGH RAMAGE, A.R.C.S.I. Plate I. (August, 1898.) 1s.
2. Radiating Phenomena in a Strong Magnetic Field. Part II.—Magnetic Perturbations of the Spectral Lines. By THOMAS PRESTON, M.A., D.SC., F.R.S. (June, 1899.) 1s.

[NOVEMBER, 1899.]

THE  
SCIENTIFIC TRANSACTIONS

OF THE

ROYAL DUBLIN SOCIETY.

VOLUME VII.—(SERIES II.)

---

III.

AN ESTIMATE OF THE GEOLOGICAL AGE OF THE EARTH.

By J. JOLY, M.A., D.Sc., F.R.S.,

Honorary Secretary of the Royal Dublin Society;

Professor of Geology and Mineralogy in the University of Dublin.

---

DUBLIN:  
PUBLISHED BY THE ROYAL DUBLIN SOCIETY.  
WILLIAMS AND NORGATE,  
14, HENRIETTA STREET, COVENT GARDEN, LONDON,  
20, SOUTH FREDERICK STREET, EDINBURGH; AND 7, BROAD STREET, OXFORD.  
PRINTED AT THE UNIVERSITY PRESS, BY PONSONBY AND WELDRICK.

1899.

---

*Price One Shilling and Sixpence.*



## INDEX SLIP.

Joly, John.—An Estimate of the Geological Age of the Earth.  
Roy. Dublin Soc. Trans., s. 2, vol. 7, 1899, pp. 23-66.

Earth, An Estimate of the Geological Age of the

Joly, John.

Roy. Dublin Soc. Trans., s. 2, vol. 7, 1899, pp. 23-66.

Geological Age of the Earth, An Estimate of the

Joly, John.

Roy. Dublin Soc. Trans., s. 2, vol. 7, 1899, pp. 23-66.



[NOVEMBER, 1899.]

THE  
SCIENTIFIC TRANSACTIONS  
OF THE  
ROYAL DUBLIN SOCIETY.

VOLUME VII.—(SERIES II.)

---

III.

AN ESTIMATE OF THE GEOLOGICAL AGE OF THE EARTH.

By J. JOLY, M.A., D.Sc., F.R.S.,

Honorary Secretary of the Royal Dublin Society;

Professor of Geology and Mineralogy in the University of Dublin.

---

DUBLIN:

PUBLISHED BY THE ROYAL DUBLIN SOCIETY.

WILLIAMS AND NORGATE,

14, HENRIETTA STREET, COVENT GARDEN, LONDON,

20, SOUTH FREDERICK STREET, EDINBURGH; AND 7, BROAD STREET, OXFORD.

PRINTED AT THE UNIVERSITY PRESS, BY PONSONBY AND WELDRICK.

1899.





## III.

## AN ESTIMATE OF THE GEOLOGICAL AGE OF THE EARTH.

By J. JOLY, M.A., B.A.I., D.Sc., F.R.S., F.G.S., M.R.I.A.,

Honorary Secretary of the Royal Dublin Society;

Professor of Geology and Mineralogy in the University of Dublin.

[Read May 17, 1899.]

**Introduction.**

THE extremes to which, in the time of Lyell, the principles of Uniformitarianism were carried did much to injure a doctrine which, properly restricted, defines the only scientific attitude open to the Geologist in dealing with the past and the future.

Rightly defined this doctrine is no other than that held and lived up to by every scientific man. It asserts that we may justly prolong into the past and future the activities of to-day, till sufficient reason be shown to interrupt them by catastrophe or change. The onus of examining into the "sufficient reason" rests with the disciple of Uniformitarianism. It is, in fact, his business to seek and define the limitations in time of the actions he is familiar with.

He differs from the Catastrophist or Convulsionist in the stringency with which he defines and examines the reasons for postulating such changes and catastrophies, and it may be said the reluctance with which he resorts to such modes of explanation. If existing operations, when extended into the past, are not in discord with probabilities, he prefers the existing operations to alternative ones, even if the latter in themselves involve nothing improbable.

The assumption of uniformity of present activities enters into many attempts to estimate the Age of the Earth dated from the beginning of those changes which may be referred to the action of water upon the face of an igneous lithosphere. Such attempts, broadly speaking, deal with the fact that a lithosphere, cooling from fusion, and then subjected to aqueous solution, is molecularly unstable in presence of the latter agency. Nor can final stability be attained till all molecular ties are remade in the common solvent, and retained under the conditions of their formation: in other words, till complete solution has been effected, and all is immersed in the common solvent. It is possible that so long as subsidence and elevation are possible, tides exist, and evaporation progresses, this state cannot be attained. To-day we find ourselves in the midst of these cycles. We perceive soils formed under subaerial actions, partly from former igneous rocks, partly from

former sediments, decaying year by year under the solvent actions to which they are exposed, and then carried away under new molecular arrangements to the common reservoir of the ocean. There further changes of molecular bonding arise, and part become diffused in solution—increasing the density of the ocean—while part form precipitates under the actions of the living or dead molecular forces existing in the new conditions in which they are placed. Thus the land would be melted down into the sea if the disturbed gravitational balance—as well as other causes—did not constantly upraise it from the water, maintaining the cycle of operations.

That these actions have progressed, broadly speaking, at a uniform rate since the earliest recognizable sediments were laid down, is a tenet which has not seriously been impugned. It has been claimed that the rate of removal of the subaerial land surface—by solution and transportation—has been, on the whole, uniform. Of course probabilities only can be advanced in support of such views which must probably for ever remain in the domain of speculative geology.

In the method of approaching the question of the Age of the Earth advanced in this paper, the foregoing tenet requires only acceptance in part—that part of it which refers to the removal of the land surface by *solution*. It has to be accepted as a preliminary step that this, on the whole, has been constant. Herein are involved a constancy, within certain fairly wide limits, of rainfall over the land areas; a constancy within fairly wide limits (which can roughly be defined) of the exposed land area, and a constancy in the nature and rate of solvent actions going on over the land surfaces. The grounds on which this amount of uniformity is accepted are given in this paper. One other tenet must be accepted, that the primeval ocean—that formed on first condensation of the water upon the land—did not contain the amount of dissolved sodium now entering so largely into its constitution. The grounds upon which this is claimed are also dealt with further on.

How can these data be used to determine what may be termed the Epigene Age of the Earth? In the sea or in its deposits those elements are recognisable which enter also into the constituents of the solid part of the Earth's crust. In the rivers these elements are also recognizable as being continually poured into the ocean. Very accurate estimates of the quantities of these elements in the ocean exist. The dissolved contents of many of the great rivers of the Earth and the mean composition and mean volume of the entire river discharge have been estimated.

Now if any of the elements entering the ocean is not again withdrawn, but is, in a word, "trapped" therein, re-appears as no extensive marine deposit, and is not laid down sensibly upon its floor; and if the amount of Uniformity already defined is accepted, evidently in the rate of annual accretion by the ocean from the rivers of this substance and the amount of it now in the ocean, the whole period since the beginning of its supply can be estimated.

Such an element is sodium. We take for this calculation the element alone, thus avoiding the obscure question of its ionisation, which does not concern the issue. The quantity of sodium now in the sea, and the annual rate of its supply by the rivers, lead, it will be seen, to the deduction that the age of the Earth is  $99 \times 10^6$  years. Certain deductions from this are—it will be shown—warranted, so that the final result of this paper will be to show that the probable age is about  $89 \times 10^6$  years. Also, that this is probably a major limit, and that considerable departure from uniformity of activities could hardly amend it to less than  $80 \times 10^6$  years.\*

In the claims to uniformity here involved, much is avoided that is most uncertain in those methods of calculation which repose upon a knowledge of the volume of sediments, removed from the land, and deduced from the geological record. Not only in the latter methods is the rate of denudation of the land surface difficult or impossible to determine with any degree of accuracy, owing to the difficulties attending determinations of the amount of sediment discharged by rivers, but the bulk of the material which has been acted upon must, to a considerable extent, be matter of speculation; for even when the best is done to determine the true thickness of the sedimentary deposits, what is missing at the unconformabilities is, in many cases, unknown.† The method used in this present estimate, on the other hand, involves two quantities, the amounts of which are ascertained with an accuracy depending only on the number of our observations: the dissolved matter in the sea (which is almost homogeneous in composition) and the average dissolved matter in the rivers of the world. That the information regarding the latter quantity available for the present calculation is not final is very probable. A complete knowledge of the dissolved solids of river discharges must involve analyses of all the principal river waters; and these chemical investigations must be combined with volumetric measurements of the discharge. In some cases such observations should be seasonal. Failing such complete knowledge, the data used in this paper may be said to afford an approximation to the nature and amount of river discharge. That no more than an approximate uniformity can be claimed for these factors over the past is doubtless true; but this does not eliminate the necessity of accurate knowledge where such is available in the application of the method, for the possibility of errors occurring of the same sign must always be borne in mind.

\* In Mr. T. Mellard Reade's calculation of a minor limit of the Earth's age from the amount of calcium sulphate in the sea ("Chemical Denudation in Relation to Geological Time." Daniel Dogue. London, 1879), the substance chosen does not possess the requisite qualifications to enter into such a calculation as is advanced here. It may be observed, as not altogether immaterial, that the principal calculations of this paper were made independently of Mr. T. M. Reade's interesting views.

† A good account of the difficulties involved appears in Wallace's *Island Life*, Chap. X.

Although the uncertainty attending the estimates of the volume of sedimentary rocks involved in the recognized geological method of prosecuting inquiry into the Age of the Earth must be admitted, it will be seen further on that the sodium contents of the sea considered in connexion with the knowledge we possess of the chemical composition of the sedimentary and igneous rocks lends support to estimates that have been made of the total bulk of the sedimentaries. Here the two methods of inquiry into the Geological Age of the Earth appear to mutually support one another.

This is involved in the following consideration which for the sake of clearness may be outlined here. The mean composition of the siliceous sedimentary rocks can be arrived at approximately by taking the average of the many reliable analyses available of various classes of such rocks as are most abundant. For present purposes, it is only necessary to consider the alkali content of these rocks. Furthermore, the mean alkali content of the principal igneous rocks, can, in a similar manner, be investigated. The mean composition of these rocks has been estimated with more especial care by F. W. Clarke of the United States Geological Survey, and the composition of the older crust of the Earth in this way approximately determined. It is in the first place found that the alkali content of the latter is considerably in excess of that of the former. Accepting now an approximate estimate of the bulk of siliceous sedimentary rocks, and restoring to this the sodium now contained in the ocean, the sodium content of the original crust, or of the average of the eruptives, is obtained with a fair degree of approximation.

Here we observe in the sodium-deficit of the detrital siliceous sediments the results of its gradual abstraction by the influences of denudation. There can surely be but this one legitimate explanation of the fact that the great bulk of the detrital sedimentaries is deficient in sodium by just that amount of this body as is contained in the ocean, plus a relatively small allowance for the deposits of Rock Salt. It is to be observed that we can effect such a restoration in the case of no other elemental body dissolved in the sea. The amount present of the chemically related substance potassium will not fit the detrital sediments. It exhibits a deficiency. For obvious reasons the calcium and magnesium salts will also be deficient.\*

An interesting fact, however, is in the case of the potassium revealed as the result of very simple calculation. The present potassium discharge of the rivers, if prolonged into the past, as the duration of this is determined by the sodium constituent, would have fed into the ocean just about the missing quantity of

\* The reasons referred to are principally the continual abstraction and precipitation of these bodies from the sea, giving rise to Limestones and Dolomites, and the presence of calcium and magnesium in the ocean sediments.

potassium. The rocks, in short, negative the view commonly urged, that the discrepancy between the alkali ratios (sodium : potassium) of rivers and ocean indicates chemical differences in the river waters of the past. It is quite the other way. Any alteration of the alkali ratio arising from a change in the potash constituent in the river water of former ages will leave the record of the rocks while correct for the soda, incorrect for the potash.

The legitimate deduction appears to be that the potash discharge of the rivers of the past is to be sought for in oceanic deposits and the sediments. This question is briefly considered in this paper.

One other important factor in the legitimacy of the conclusions arrived at in this paper may be referred to here. The assumption that the early waters of the ocean did not contain the sodium at present forming so large a part of its total solid contents is supported, not only as a deduction of the facts just quoted, but by a consideration of the silicated state of the elements on a lithosphere cooling from fusion, and the subsequent effects on such a magma or crust of any probable abundance of acids derived from the chlorine of the ocean, were this free to form hydrochloric acid. It is submitted that such a body of acid vapour and liquid would be neutralised by the various silicated bases, and divided in such proportion among these as would result in what is relatively a small quantity of sodium chloride brought into solution. Our knowledge of the relative abundance of the elements in the Earth's lithosphere enables a very definite allowance for this primæval action to be effected.

The consideration of the question of the uniformity in the rate of denudation involves inferences based on the known deficiencies of rainfall in many parts of the Earth's surface—the "rainless" regions. Where such exist, there will be elasticity as regards subsidence or upheaval and rate of denudation into the ocean. The first causes the inward retreat upon the land of the watershed defining the oceanic supply, the second its outward advance. But there is no reason to suppose the amount of supply will on the whole vary. There is such elasticity to-day to the extent of one-fifth the total land surface of the globe.

In the next place, the nature of the soils derived from rocks of very various origin enters into consideration. Our existing knowledge shows that there is remarkable uniformity in these, whether derived from igneous or sedimentary rocks. It is in the soils that solvent denudation is chiefly effected. The greater alkali content of the eruptives—leading to their more rapid yield of those substances on first breaking down—is probably compensated by their physical character, in many cases conferring greater durability upon them. These and other considerations lead to the view that there is no sufficient evidence to ascribe greater alkali content to the rivers of the past.

The origin of the interstratified beds of Rock Salt, the solvent-denudation of

the sea, and the order of magnitude to be ascribed to an allowance for the latter, are briefly considered in the paper, as well as other questions which arise.

When all corrections are made and the requisite latitude of error taken into account, it would appear that the consideration of solvent-denudation, points to an Age for the Earth, dating from the settlement of water upon its surface, of between 80 and 90 millions of years.

### I.—The Estimate of Geological Time.

On the basis that the ocean possesses an average depth of 2000 fathoms, and occupies  $\frac{8}{11}$  of the area of the globe, its total mass is calculated to be  $1\cdot322 \times 10^{18}$  tons.\* Its ingredients in solution are:—

Chloride of sodium, . . . .	77.758
,, of magnesium, . . . .	10.878
Sulphate of ,, . . . .	4.737
,, of lime, . . . .	3.600
,, of potassium, . . . .	2.465
Bromide of magnesium, . . . .	0.217
Carbonate of calcium, . . . .	0.345
	100.000

and the total salts are approximately 3.5 per cent. of the mass of the whole.

On these data, the absolute masses of the ingredients of the ocean are calculable:—

NaCl, . . . .	$35990 \times 10^{12}$ tons.
MgCl <sub>2</sub> , . . . .	5034 ,, ,,
MgSO <sub>4</sub> , . . . .	2192 ,, ,,
CaSO <sub>4</sub> , . . . .	1666 ,, ,,
K <sub>2</sub> SO <sub>4</sub> , . . . .	1141 ,, ,,
MgBr, . . . .	100 ,, ,,
CaCO <sub>3</sub> , . . . .	160 ,, ,,
	46283 ,, ,,

Of the sodium chloride, 39.32 per cent. is sodium. In the sea, there is, therefore, a mass of sodium in solution amounting to  $14,151 \times 10^{12}$  tons.

Sir John Murray,† as the result of the analyses of 19 rivers—many of which

\* Encyclopædia Britannica—Article, “Sea.” The analyses are Dittmar’s from the Reports of the “Challenger” Expedition.

† Scottish Geographical Magazine, 1887, p. 76.

are principal rivers of the world—arrives at the following estimate of the dissolved materials in tons per cubic mile of river water :—

	Tons.
CaCO <sub>3</sub> , . . . .	326710
MgCO <sub>3</sub> , . . . .	112870
CaSO <sub>4</sub> , . . . .	34361
Ca <sub>3</sub> P <sub>2</sub> O <sub>8</sub> , . . . .	2913
Na <sub>2</sub> SO <sub>4</sub> , . . . .	31805
K <sub>2</sub> SO <sub>4</sub> , . . . .	20358
NaNO <sub>3</sub> , . . . .	26800
NaCl, . . . .	16657
LiCl, . . . .	2462
NH <sub>4</sub> Cl, . . . .	1030
SiO <sub>2</sub> , . . . .	74577
Fe <sub>2</sub> O <sub>3</sub> , . . . .	13006
Al <sub>2</sub> O <sub>3</sub> , . . . .	14315
Mn <sub>2</sub> O <sub>3</sub> , . . . .	5703
Organic matter, . . . .	79020
	762587

He further estimates that the total volume discharged by the rivers *into the ocean* is 6524 cubic miles per annum.

Taking 32·40 per cent. of the sodium sulphate, 27·06 per cent. of the sodium nitrate, and 39·32 per cent. of the sodium chloride as sodium, we obtain a total mass of sodium of 24,106 tons per cubic mile; and multiplying this number by the number of cubic miles of river water annually discharged into the ocean, we find that this amounts to 157,267,544 tons.

The quotient of  $14,151 \times 10^{12}$  divided by  $15,727 \times 10^4$  is very nearly  $90 \times 10^6$ .

From these data then the period of time required to supply its present amount of sodium to the ocean by rivers possessing the average approximate compositions of the existing rivers would be ninety millions of years.

The foregoing figures admit of amendment as the result of a more recent estimate of the volume of the ocean by Sir John Murray.\* He estimates the volume as 323,800,000 cubic miles, very closely. Taking the weight of a cubic mile of sea-water as  $43 \times 10^8$  tons, this affords a mass in tons of  $1\cdot392 \times 10^{18}$  or a mass 5·3 per cent. nearly, in excess of that previously assumed; which of course raises the figures obtained for geological time in years by a corresponding amount. Thus, on this more carefully estimated basis the period of geological denudation becomes  $94\cdot8 \times 10^6$  years nearly.

But this number admits of still further amendment on another and perhaps more complete estimate of the oceanic area. Prof. Hermann Wagner† reconsiders Sir John Murray's estimate just quoted, and arrives at the result that the whole

\* Scottish Geographical Magazine, 1888, p. 1.

† Scottish Geological Magazine, 1895, p. 185.

land surface of the globe is 55,814,000 square miles, and that the oceanic area bears to this the ratio of 2·54 to 1. On this estimate, and accepting Sir John Murray's estimate of the mean depth of the ocean (2076 fathoms = 2·393 miles) the bulk of the ocean in cubic miles is 339,248,000. This gives a mass of  $1·460 \times 10^{18}$ , of which the sodium constitutes  $15,627 \times 10^{13}$  tons, and the period of denudation arrived at is 99·4 millions of years.

This is probably the most accurate basis on which to obtain this quotient, and will be accepted in what follows. The estimate will be modified to some extent on further considerations.

## II.—The Original Condition of the Ocean.

The existence of primitive high temperature conditions affecting the materials of which the Earth is composed is inferred as the result of many observations and analogies. These need not be referred to here.

The globe, as we find it, possesses as its lithosphere siliceous and aluminous compounds which are volatile only at temperatures probably much exceeding 2000° C., and carbonates of the alkaline earths which, at a much lower temperature, dissociate into a gaseous oxide and stable solid oxides. In the hydrosphere now enveloping a large part of the lithosphere, we find a vast bulk of water, gaseous at all pressures above the temperature 370° C., and dissolved in it a quantity of a halogen salt sufficient in amount—as may be easily shown—to cover the entire globe to a depth of 112 feet if crystallized out into solid sodium chloride.

The effect of a temperature so elevated as 1500° C. upon the materials of the Earth's surface will then result as follows, according to our laboratory experiments:—

The carbonic anhydride will, if previously formed, exist in a stable state; free oxygen and hydrogen will represent the present ocean, water gas ceasing to be stable at normal pressures at temperatures somewhat over 1200° C. The alkaline earths, the iron, and the alkalis will be silicated and exist as lime, magnesium, iron, sodium, and potash aluminium silicates in a state of fusion. Quartz melts below 1500° C. and the largely preponderating number of silicates possess melting points ranging between 900° and 1500° C.\*

The chlorine now combined—as assumed—with the sodium in the sea, will have entered most probably into combination with the hydrogen and exist as hydrochloric acid gas. This compound is stable up to 1700° C. nearly.†

That the sodium chloride could not exist as such is shown in the every-day

\* "The Melting Points of Minerals." By J. Joly. Proc. R.I.A., 1891, II., p. 44.

† See the investigation of the stability of the compounds referred to by Carl Langer and Victor Meyer. "Pyrochemische Untersuchungen." Braunschweig, 1885.



operations of the pottery kiln, whereby common salt is decomposed in presence of water vapour, the sodium uniting with the oxygen of the water vapour, and the heated earthenware to form sodium aluminium silicate, and the chlorine with the hydrogen of the water vapour to form hydrochloric acid. The glaze produced in this way on the earthenware is highly insoluble.

Under this condition of temperature a gaseous pressure, of not less than 300 atmospheres—probably between 300 and 400—must have obtained, due to the oxygen, hydrogen, carbonic anhydride, and hydrochloric acid. This pressure cannot, however, be supposed to have influenced the chemical combinations occurring in the liquid silicated magma of the Earth's surface.

If we transfer our attention to a later epoch, when a temperature of, say,  $1000^{\circ}\text{C}$ . was attained, we observe that water vapour would be stable, and a crust would be forming upon the surface of the Earth. We find now events progressing in this early solid crust which have already been indicated by Lord Kelvin.\* The break up and submergence of the denser solid constituting the crust would certainly lead to a considerable intermingling of layers probably previously differentiated by specific gravity acting on a mass which was hardly likely to be molecularly homogeneous throughout. We must note, however, that this action can only have extended to comparatively shallow depths, as such descending fragments would soon find themselves buoyed up and re-fused by the denser magma beneath.

Observations on the behaviour of silicates at high temperature show that these bodies are stable for the most part, certainly up to  $1500^{\circ}\text{C}$ ., but upon complete fusion readily yield up included or combined water. Still, under the conditions of pressure and temperature obtaining at the surface of the Earth at the period we refer to, it is probable that much volatile matter was held in solution in the melted magma, and ultimately trapped in the solid crust. How far this was a glass, or how far crystalline differentiation had progressed, does not much concern the present issues, and is, in any case, difficult or impossible to determine.

We now transfer our attention to yet another period of the Earth's early history. An eventful period, when the temperature near or at the surface had fallen to the critical temperature of water,  $370^{\circ}\text{C}$ . At this temperature a pressure of 196 atmospheres would suffice to liquefy it. The pressure was very probably much above this even at points high up in the atmosphere.

When this critical temperature was attained at such a point in the atmosphere as to be attended by pressure conditions exceeding the critical pressure an instant change of state occurred. The water resulting—almost still a vapour, but possessing a surface, although a highly energetic one—probably floated in the equally

\* "On the Secular Cooling of the Earth," and "On the Rigidity of the Earth." *Mathematical and Physical Papers*. Vol. III. See also Green's "Physical Geology," 1882, p. 655.

dense vapour, or sinking into hotter layers beneath immediately resumed its vapourous state. Its condition was, in fact, highly unstable as regards upward or downward motion;\* finally the temperature sank till water established itself upon the surface: here and there over hotter areas doubtless flashing into vapour, but gradually gaining a resting-place upon the surface.† For a long period the fall in pressure attending its own condensation must have maintained it in a state of ebullition.

Effects were produced at this stage which may well claim here a moment's consideration.

Sensible shrinkage due to secular cooling, and the great earth-folding which has since wrinkled the Earth's surface had not yet taken place. Let us suppose a depression anywhere upon the comparatively uniform surface receiving the precipitated water. Over this area the pressure is increased, elsewhere it is reduced. The effect of this is to cause, on the one hand, a further depression of the early sea bottom, and to establish a drainage into it, and on the other to facilitate the expansion and extrusion of any heated volatile matter held in solution in the lavas beneath the dry land; a diminution of density of the land masses and corresponding upheaval. Further precipitation of water would widen and deepen the early oceans. Finally the uniform pressure of about 300 atmospheres becomes concentrated as a pressure of some 400 atmospheres over perhaps  $\frac{1}{11}$  of the Earth's area, if we assume some such concentration of water as at present exists. The several conditions attending the gradual precipitation of the gaseous envelope upon the surface render it improbable that a uniform ocean covering the entire globe ever existed, even if it *could* have remained in equilibrium on a thinly crusted Earth possessing an energetic substratum.

The effects of this new distribution of pressure must have been to flood the land areas with lavas extruded from beneath. A change of pressure of from 300 atmospheres to one comparatively nil might be represented by an unloading of our present continental areas to the extent of 3600 feet of rock of a specific gravity of 2.5.‡ And this unloading must have been effected in a comparatively short period—"instantaneously," if contrasted with the slow unloading effected by denudation.§ Such a redistribution of pressures must have inaugurated remarkable

\* "A Theory of Sunspots." By J. Joly. Roy. Dub. Soc. Proc., N.S. Vol. VIII., 1898, pp. 697-700.

† Professor Sollas, F.R.S., in his lectures in dwelling on the facts of the inception of ocean basins, has frequently pointed out that these must have dated from the rainfall attendant on the fall of temperature to the critical temperature of water.

‡ One effect of this would be that over the land surfaces the melting point of a rock such as Diabase would be raised about 8° C. This would tend to confer some greater rigidity on the exposed crust of the earth.

§ It is not to be supposed that tidal disturbances permitted this allocation of the surface to take place quietly, and without swaying at each vibration of our satellite, then possibly much closer to the terrestrial surface.

lithological differences in the subaqueous and subaerial portions of the lithosphere. It is to be anticipated that beneath the ocean the effects of the primordial conditions of fusion in presence of volatile matter at high pressure would be more perfectly preserved than over the early land areas, where the reduction of pressure and still shallow crust would tend to the expansion and extrusion of the original magma. A diminished mean density of the sub-oceanic crust does not, however, necessarily follow. On the contrary, the conditions of greater pressure under which it was formed must be supposed to have conferred greater density upon it, and to have favoured the differentiation and crystallization of the denser silicates. If sufficient time elapsed for these differences to become deeply established in the crust of the Earth, a subsequent reversal of the distribution of pressure must be improbable. It is difficult to conceive that the limited range of transportation attending denudation can have led to any extensive subsequent redistribution of equilibrium. Tidal convulsions would appear to be the only refuge of those who object to the permanence of the continents.\*

The upper part of what is now the Earth's solid crust must, as we have urged, have contained, as silicates in the form of slag, lava, or rock, the alkaline earths now appearing chiefly as carbonates, the alkalis now distributed between the salts of the sea and the alkali silicates of the rocks, along with iron and alumina. The early hydrosphere must, for want of other known alternative, be supposed to have contained a quantity of hydrochloric acid roughly represented by the chlorine now in the ocean. Carbonic anhydride also entered into its composition, and the atmosphere, enveloping all, must have still been largely in excess of our present atmosphere, principally owing to the presence of carbonic anhydride and hydrochloric acid. The waters of the early ocean, and the rain which then fell upon the lavas and rocks of the land, possessed solvent powers greatly in excess of what we at present observe. Those who have maintained that the sea was "salt" from the first, if they paused here, would doubtless find considerable support to their views; and, of course, the right or wrong of the matter turns upon what one means by "salt." We are only concerned now with one element of the ocean, the sodium, and it will be easy to show that complete neutralisation of the acid hydrosphere would have been attended, by only a relatively small introduction of sodium into the ocean.

We can make a rough estimate of the results of this primeval chemical denudation—and hence of the correction on the estimate of geological time involved in the primitive saltiness of the ocean—by allocating the action of the acid among the constituents of the early crust; but we have first to inquire into the percentage relations of these constituents.

\* See "Physics of the Earth's Crust" (by the Rev. Osmond Fisher: Macmillan & Co., 1889, pp. 297, 298), where increased density of the lithosphere beneath the ocean is for other reasons inferred.

Mr. F. W. Clarke has estimated the percentage amounts of the elements contained in the Earth's surface crust. In Mr. Clarke's first report,\* the mean of 880 selected analyses of American and European igneous, volcanic, and crystalline rocks is tabulated along with the means of the component analyses divided into local groups, as the rocks of the Western States, of Northern California, of European volcanic and crystalline rock, &c.; and it is remarked as the result of comparing these groups that "the thesis that the crust of the Earth is fairly homogeneous in composition is thus sustained by positive evidence." In a later publication,† 960 analyses are consulted, and these of a still more carefully selected and reliable character, giving an average "which may fairly represent the composition of the older crust of the Earth." The result, which closely agrees with the earlier estimate, is contained in the column below.

SiO <sub>2</sub> ,	. . . . .	59·77
Al <sub>2</sub> O <sub>3</sub> ,	. . . . .	15·38
Fe <sub>2</sub> O <sub>3</sub> ,	. . . . .	2·65
FeO,	. . . . .	3·44
CaO,	. . . . .	4·81
MgO,	. . . . .	4·40
K <sub>2</sub> O,	. . . . .	2·83
Na <sub>2</sub> O,	. . . . .	3·61
H <sub>2</sub> O,	. . . . .	1·51
TiO <sub>2</sub> ,	. . . . .	0·53
P <sub>2</sub> O <sub>5</sub> ,	. . . . .	0·21
		99·14

This approximates to a Diorite, and would fall among Rosenbusch's series of "Granito-dioritischen" and "Gabbro-peridotitischen" magmas.‡

Such a rock or lava attacked by a heated solution of hydrochloric acid must ultimately yield its iron, calcium, magnesium, potash, and soda as chlorides. The atomic percentages of Clarke's average are given by him as follows:—

Iron,	. . . . .	4·71
Calcium,	. . . . .	3·53
Magnesium,	. . . . .	2·64
Potassium,	. . . . .	2·35
Sodium,	. . . . .	2·68

The chlorine taken up may be assumed to be distributed as follows: in the first instance—Fe<sub>2</sub>Cl<sub>6</sub>, CaCl<sub>2</sub>, MgCl<sub>2</sub>, KCl and NaCl.

\* Bulletin of the United States Geological Survey, No. 78, 1891, p. 34.

† Bulletin of the U.S. Geological Survey, No. 148, 1897, p. 12.

‡ Elemente der Gesteinslehre. Stuttgart, 1898, p. 187. See No. 15 of this group for a rough approximation to Clarke's average.

The chlorine will be allocated as follows among these elements :—

4·71 units of weight of iron take up 9·0 units of chlorine nearly; 3·53 units of calcium join with 6·3 units; 2·64 units of magnesium take up 7·6 units; 2·35 units of potassium, take up 2·14 units, and 2·68 units of sodium unite with 4·1 units of chlorine. From this it follows, that the chlorine taken up by the sodium bears to the total amount of acid neutralised the ratio of 1 to 7·5. If then there had not been any supply of chlorine subsequently from the rocks, as there has been, this would represent the fraction of the present sodium chloride which was, with comparative rapidity, thrown into the primeval ocean, in the first stages of denudation. In other words, of the entire quantity of HCl at that early period neutralised by reaction with the constituents of the rocks, only 14 per cent. can have been expended in bringing the sodium into solution as sodium chloride.

If, therefore, we estimate the chlorine in the original ocean, we may, on the foregoing basis, take 14 per cent. of this as having existed in it as sodium chloride.

In estimating the chlorine in the primeval ocean, we have to consider that what is now in it is in excess, to some extent, of what originally existed in it by the amount that has been discharged by the rivers during the subsequent history of the Earth. Clarke shows that careful analysis of rocks reveals this element in many rocks wherein it had previously not been looked for. He estimates that it exists to the extent of 0·01 per cent. of the original crust.\* In river discharges it will be seen (*ante*) to amount to no inconsiderable amount, entering chiefly as chloride of sodium, but also as lithium and ammonium chloride. The chloride of sodium is undoubtedly partly derived from the sea itself. It enters into the composition of rain-water in districts bordering or near the sea. It would appear that further inland it is an inappreciable constituent of rain-water. At Rothamstead, the average of seventy-one analyses afforded 0·33 of chlorides in 100,000. At Land's End, this rose to 21·8 in 100,000. On the west and east coasts of Scotland, it is 1·19 and 1·26 respectively per 100,000. In London, it is 0·12, and in Ootacamund, India, it is only 0·04 per 100,000 parts,† the latter town being some three hundred miles from the coast in South India. The amount in British rivers free from pollution is 1 in 100,000; and evidently, as these represent a concentration to one-third of the rainfall, this amount would be accounted for by the chlorine carried from the sea.

This is not the case with the great rivers of the world. Many of these must derive their chlorides from the rocks by solvent denudation.‡ Some deduction

\* Bulletin U.S. Geological Survey, No. 148, p. 13. See also Bischof's "Chemical and Physical Geology."

† Thorp's "Dictionary of Applied Chemistry"—Article, "Water."

‡ See Bischof's "Chem. Geology," chap vii., vol. i. English Edition, 1854. Bischof thinks the rivers can carry back to the sea only very little from the beds of rocksalt (p. 111).

should, however, be made for the supply referable to the sea. A deduction of 10 per cent. is probably sufficient; it is a correction on a correction. This need be applied to the sodium chloride only, reducing it from 16,657 tons per cubic mile to 15,000 tons in round numbers; and multiplying by the number of cubic miles of river discharge, the total annual supply to the ocean is  $97.8 \times 10^6$  tons of sodium chloride. There are also  $16 \times 10^6$  tons of lithium chloride, and  $6.5 \times 10^6$  tons of ammonium chloride. These quantities include a total of nearly  $76 \times 10^6$  tons of chlorine. If we assume that the final result as to the duration of denudation will not be far from  $86 \times 10^6$  years, we arrive at a total deduction of  $6536 \times 10^{12}$  tons as a correction on the amount of chlorine contained in the sodium chloride of the ocean.

On the other hand, however, an estimate of the total quantity of chlorine in the ocean must take into account the quantity of magnesium chloride present in it. This, calculated on the most recent estimate of the mass of the ocean referred to, *ante*, amounts to  $5568 \times 10^{12}$  tons, containing  $4161 \times 10^{12}$  tons of chlorine. The total chlorine in the original ocean is arrived at by adding to  $24,155 \times 10^{12}$  tons contained in the chloride of sodium,  $4161 \times 10^{12}$  in the magnesium chloride, and subtracting  $6536 \times 10^{12}$  as subsequently introduced. The result is  $21,780 \times 10^{12}$  tons.

We can now apply these figures to correct the original estimate of geological time which assumed that *all* the sodium in the ocean had been delivered by the rivers.

According to the results obtained by considering the effects of solution of a primitive crust approximating to the present eruptive and igneous constituents of the Earth's crust, 14 per cent. of the chlorine fixed in the salts brought into solution would be united with sodium. This we now find will amount to  $3049 \times 10^{12}$  tons, combining with  $1972 \times 10^{12}$  tons of sodium. But we have already seen that to-day there are  $15,627 \times 10^{12}$  tons of sodium in the ocean. The correction is 12.6 per cent. This on the period of  $99.4 \times 10^6$  years is  $12.5 \times 10^6$  years nearly, which is evidently a subtractive correction, and reduces the estimate of geological time to  $86.9 \times 10^6$  years.

This correction is based on the view that the chlorine now in the ocean—or nearly this amount—must originally have been free in the atmosphere and hydrosphere. This is assumed as the only alternative open to us in disposing of this substance. Previous writers have accepted this view. If free it can hardly have been otherwise combined than with hydrogen. The dissociating temperature of HCl is some  $500^\circ$  above that of water; hence the chlorine would have taken its hydrogen before the formation of water was possible.

Serry Hunt has further assumed that sulphur, in the form of acid gas, entered into the composition of the primeval atmosphere. The early high temperature

condition would result in "the conversion of all carbonates, chlorides, and sulphates into silicates; and the separation of the carbon, chlorine, and sulphur in the form of acid gases, which, with nitrogen, watery vapour, and a probable excess of oxygen, would form the dense primeval atmosphere."<sup>\*</sup>

That sulphuric acid existed in the early atmosphere and hydrosphere in, at least, relatively small quantities, is more than probable. In the sea-salts of to-day it forms a relatively small part, and is being supplied by the rivers at a rate which, acting over geological time, is far more than sufficient to account for all that is in it. † It is being constantly thrown down upon the ocean floor in the form of calcium sulphate; constituting about 0·7 per cent. of the red clay, and 0·4 per cent. of the Radiolarian ooze, 0·3 per cent. of the Diatom ooze, and about 0·8 per cent. of the Globigerina ooze, as well as entering into other extensive floor-deposits of the ocean. Sulphur exists, according to Clarke, as a constituent of the fundamental crust, amounting to 0·06 per cent. We find then not only a source of supply in the rocks, but an annual river supply more than adequate to account for what is in the ocean. We cannot, therefore, fairly make allowance for its solvent action in early times. If free, it probably existed in relatively minute quantities.

In the case of carbonic acid we can effect a fairly satisfactory estimate of its amount from the volume of limestone rocks now on the Earth's surface; but in the case of this acid we find a much less energetic body than hydrochloric acid. Its activity has probably extended all through geological time, and its gradual absorption been marked by the limestones of all ages. We must bear in mind, however, what has frequently been pointed out—that the volcanic extrusion of this substance throughout geological time has probably been considerable.

The only warranted correction of large amount appears, then, to be that due to the attack upon the early rocks by the hydrochloric acid. We make a deduction of 12·5 millions of years for the primeval salinity of the ocean brought about by this means. It is, however, evident that the solution of this amount of material was not effected instantaneously, but by an accelerated denudation, extending over some period of time, the duration of which, we can satisfy ourselves, however, is nearly negligible. A rough estimate of the amount of denudation, as a layer of rock removed from the whole terrestrial land surface, is easily arrived at.

We have already found, in fact, that  $1972 \times 10^{12}$  tons of sodium must, roughly, have been dissolved out of the primeval rocks. In Clarke's table of the

<sup>\*</sup> "Chemical and Geological Essays," 1897, p. 40.

† The annual river supply of the element sulphur is about  $124 \times 10^6$  tons, and the mass of S in the ocean is about  $12 \times 10^{12}$  tons. A part of the sulphates of the rivers is derived from rain, and hence from the sea.

atomic ratios of the constituents of these rocks, sodium appears as 2.68 per cent. The entire mass of rock reduced to detrital sediment and brought into solution to supply this amount can, of course, be estimated from this. It amounts to  $73 \times 10^{15}$  tons. On Professor Wagner's determination already referred to, the area of the globe is about  $1965 \times 10^5$  square miles; and taking the specific gravity of the original rock to be that of Diorite (2.95), we find the amount denuded would cover the Earth to a depth of 157 feet.

The most careful estimate of the present mean rate of subaerial denudation of eruptive and crystalline rocks amounts to about 1 foot in 3000 years, removed from the surface, partly in solution, partly by transportation, to the rivers and sea. The primeval ocean was, according to our view, a dilute solution of HCl.

Bearing in mind the fact that the solution of hydrochloric acid would become impoverished as time progressed, and insoluble residues cover up a fraction of the Earth's surface, it would seem to be sufficient to assume that its mean rate of activity was five times that of present subaerial agents. This affords 1 foot in 600 years; or to denude 157 feet of rock, 94,200 years. In fact, even at the present rate of denudation, the large surface we have assumed as exposed to denudation reduces the period of time required to remove such a rock-layer to a negligible duration. The only correction that is admissible would be a unit in the decimal place of our correction of  $12.5 \times 10^6$  years, reducing the correction to  $12.4 \times 10^6$  years, and leaving geological time, dated from the condensation of water upon the globe, to be  $87 \times 10^6$  years.

The foregoing corrections involve not only the assumption that the hydrochloric acid was free, but also that we may assume from the mean analyses of igneous, eruptive, and crystalline rocks, a knowledge of the primeval crust exposed to denudation. The latter assumption appears justified, not only for the reason that any other is gratuitous and *prima facie* unwarranted, but also from the fact that the sodium contents of the sedimentaries, as now existing, if increased by what is now the ocean, reverts very nearly to that of Clarke's primary crust.

The assumption of this acidic denudation of the primeval rocks leaves the ocean charged principally with chlorides at the dawn of geological history. Carbonates must also have entered into the composition of the primeval ocean, probably as minor constituents. Sulphates possibly also existed in relatively small quantities.

Sterry Hunt believed that the waters imprisoned in the pores of the older stratified rocks, and which are "vastly richer in salts of lime and magnesia than those of the present sea," might be regarded as the fossil sea-waters of the ancient ocean. He gives a theory of the subsequent changes in ocean chemistry: suggesting that the carbonates of the alkalis and the alkaline earths in



subsequent geological history carried to the sea by the rivers, would first precipitate the dissolved alumina and the heavy metals, "after which would result a decomposition of the chloride of calcium of the sea-water, resulting in the production of carbonate of lime or limestone, and chloride of sodium or common salt."\*

### III.—The Supply of Sodium by the Rivers.

Before turning to other considerations, we must attend to a correction which we have already touched upon, and which is not negligible. In deducting from the river supply of sodium a quantity equal to 10 per cent. of the sodium chloride as being derived directly from the sea, we evidently reduce our divisor, and so increase our estimate of Geological Time. The deduction of 10 per cent. can of course be accepted as no more than a rough allowance—possibly a little excessive.

The quantity of sodium chloride thus assumed as derived from the sea is 1657 tons per cubic mile of river water, or  $108 \times 10^3$  tons for the entire annual river discharge. Calculating the sodium only, this becomes  $42 \times 10^3$  tons per annum. We have already calculated the quantity of sodium in the ocean of to-day, and found it to amount to  $15,627 \times 10^{12}$  tons. But of this we have reason to believe  $1972 \times 10^{12}$  tons are to be ascribed to the rapid denudation of the original rocks, leaving  $13,655 \times 10^{12}$  tons to be accounted for by subsequent supply from the rivers. This river supply amounts to a total of  $15,727 \times 10^4$  tons per annum, to which must be applied the correction for the observed supply to rivers of sodium abstracted from the sea and precipitated upon coastal countries by rain-water. This, as we have just seen, is estimated at  $42 \times 10^3$  tons per annum. Hence the river supply is now reduced to  $15,307 \times 10^4$  tons. The quotient of  $13,655 \times 10^{12}$  by  $15,307 \times 10^4$  is  $89.2 \times 10^6$ . To this number of years may be added the decimal  $0.1 \times 10^6$  years as the period approximately required to effect the denudation of the primitive rocks to the extent of fixing the free hydrochloric acid, giving, finally, as the estimate of the duration of denudation,  $89.3 \times 10^6$  years.

It must not be understood from the foregoing that we claim a degree of accuracy for our estimate approximating to so small a time interval as 100,000 years. The period is only taken into account as arising from our figures. It will be seen later on that a far larger margin of error is of necessity assumed.

\* "Chemical and Geological Essays," 1897, p. 41. See also Bischof's "Chemical and Physical Geology," London, 1855, Vol. I., p. 7; and Sir A. Geikie's "Text-Book of Geology," 3rd ed., p. 412, "Deposits in Salt and Bitter Lakes."

It will conduce to clearness to summarise here a statement of the corrections.

Basis of Calculation.	Duration, in millions of years, of Geological Time since Condensation of Water on the Globe.
1. If no free acid existed in the primeval atmosphere and the total river supply of sodium be assumed as derived, at a uniform rate, from the rocks, . . .	99·4
2. As 1; but assuming that free acid in the original atmosphere, to the extent calculated from the chlorine now in the sea, less that subsequently supplied by rivers, attacked the original rocks, and became neutralised in negligible time, . . .	86·9
3. As 2; but allowing for a period of acid-denudation at a rate 5 times the average rate of present sub-aerial denudation, . . .	87
4. As 3; and assuming 10 per cent. of the sodium chloride in the river discharge to be derived from the ocean, . . .	89·3

Of these estimates number 4 is based on the most complete estimate of probabilities.

We have still to consider known or possible sources of disturbance which, with our present knowledge, hardly admit of numerical approximation. We hope to show, however, that the resultant of their often opposed effects was probably subtractive, and must be included in an allowance of about 10 per cent.

#### IV.—The Saline Deposits.

Very considerable deposits of Rock Salt, &c., occur among bedded rocks of various ages—even those of early Palæozoic times—as the Salt Range of the Punjab, which dates back to Cambrian age.\* That these in the aggregate represent a very considerable mass of sodium chloride cannot be doubted, although their local character and limited extent reduces this amount probably to but a small fraction of that contained in the sea.

It is believed by some geologists that such beds were derived from the sea by enclosure of bays, &c., and evaporation to dryness of the land-locked water. There are, however, many arguments for believing that such occurrences must have been rare, and for the support of the opposed view that they represent the deposits of areas deficient in rainfall. In the hypothetical, a bar must occur

\* Sir A. Geikie's "Text-Book of Geology," 3rd ed., p. 737.

by crust elevation in such a position as to cut this off and imprison the water. This must be effected sufficiently rapidly to overtake the tidal scour which proves the more effective in preserving the channel of communication with the sea the more narrow the channel becomes. But this is not all. The land-locked bay is very unlikely to contain the salts adequate to account for the thickness of the beds and periodic variations formed in the deposit. Fresh influx of sea-water must be therefore obtained, or the advocates of this view must now join hands with the advocates of the rival theory, and claim "rainless" conditions to finish the deposition of salts in the enclosed area.

In the best example known of a salt lake of marine origin (the Caspian Sea), the waters, as a whole, are not so saline as those of the Mediterranean. Ultimately evaporation must, however, lead to extensive salt deposits in this sea. But these will only to a fractional extent be derived from the sea. "Salt lakes of oceanic origin are comparatively few in number";\* and we see by this example of one, that it by no means follows that the salt deposits so derived ever formed part of the original ocean save to a small extent.

The ordinary history of the Rock-Salt deposit is undoubtedly that of the majority of the present salt lakes of the world. The formation of such deposits is indeed inevitable wherever a depression and rainfall below the amount required to flood the depression to repletion exist. The inflow from the rain to such an inland basin indeed diminishes as the basin fills up, and the evaporation correspondingly increases. When the latter balances the rain supply, the waters continue to grow in salinity, till a salt lake—derived from denudation within the watershed—is formed. Such have been formed in all ages at periods even older than the Silurian. Thus "some of the more important beds of America belong to Upper Silurian, Carboniferous, Triassic, or Tertiary ages, and vary in thickness from a mere film to upwards of 1200 feet," and are ascribed, by Mr. G. P. Merrill, to the evaporation of water in inclosed lakes and seas.†

So far as our present theory is concerned there is no need to take these into consideration; for, in point of fact, they are already considered in the estimate of river supply to the ocean furnished by Sir J. Murray, which takes into account only that falling directly into the ocean. The drainage of the "rainless" regions of the Earth—regions where the rainfall is less usually than 11 inches per annum, and which do not drain into the sea—is excluded. As in the present so in the past, we conclude that such regions existed scattered over the land surface at various periods of the Earth's history; and we find no better confirmation of the preservation of present climatic conditions than exists in these tell-tale beds of

\* Sir A. Geikie's "Text-Book of Geology," 3rd ed., p. 410.

† G. P. Merrill's "Treatise on Rocks and Rock Weathering and Soils," p. 120, 1897.

saline deposits. They furnish a striking support to the Uniformitarian views here advocated.

At the best the stratified salt deposits of the Earth must form only a very small fraction of what has accumulated in the waters of the ocean. The Rock Salt of the latter would cover the entire dry land of the Earth to a depth of 400 feet. The other deposits are entirely local, and but rarely attain this thickness. We see from what has been said that the fractional part of some of these deposits, which actually go to throw error into our calculations, makes so small a part of a small correction, that we are not concerned with its estimation.

#### V.—The Alkalies of the Rocks.

It is a fact of great interest in connexion with our present consideration that the igneous and eruptive rocks, as a whole, possess an amount of soda alkali which preponderates over potash alkali, while, in the case of the sedimentary rocks, this is in the very large number of cases reversed, the potash alkali exceeding the soda alkali.

This becomes clear in the light of what we have already considered as regards the gradual derivation of the salts of the ocean in the process of formation of the sedimentaries, coupled with the fact that, under or during conditions of weathering, potash aluminium silicates are more resistant than soda aluminium silicates. This and another cause for the retention of the latter salts will be reverted to again. The fact we wish to dwell on here is the ultimate one that this chemical distinction, broadly speaking, exists between the igneous and sedimentary rocks. We shall also find that the restoration of the known amount of sodium in the ocean to the sedimentary rocks will bring them up to the sodium percentage of the igneous rocks. A like restoration cannot be effected for the potash alkali owing to reasons we have briefly to point out further on.\*

The average igneous and eruptive primitive crust-rock arrived at by Mr. Clarke (*ante*) possesses the alkali percentage.

K <sub>2</sub> O,	.	.	.	.	.	2·83
Na <sub>2</sub> O,	.	.	.	.	.	3·61

This we may compare with the results of averaging the rock analyses selected by H. Rosenbusch in his “*Elemente der Gesteinslehre.*”†

\* In dealing with this question in this and the ensuing section the sodium and potassium of the sea will be calculated as the oxides for the convenience of frequent references to rock analyses.

† Stuttgart, 1898.

These may be tabulated as follows (the references are to the pages of the work referred to):—

	K <sub>2</sub> O.	Na <sub>2</sub> O.
<i>Eruptive rocks—</i>		
Mean of 19 Liparites, Trachytes, Basalts, &c. (p. 35),	3.03	4.37
<i>Plutonic rocks—</i>		
Mean of 18 Granites (p. 78), . . . . .	4.26	3.80
„ 46 Syenites (pp. 106–126), . . . . .	5.60	6.80
„ 25 Diorites (pp. 140, 141), . . . . .	1.86	3.82
„ 6 Essexites (p. 172), . . . . .	2.49	4.68
„ 8 Theralites and Shonkinites (p. 176), . . . . .	3.86	4.98
„ 14 Gabbros (p. 151), . . . . .	0.77	2.62
Mean of eruptive and plutonic rocks,	3.11	4.44
Also the following dynamically altered eruptive rocks :—		
Mean of 5 Porphyroids and Sericite-gneisses (p. 440),	6.44	1.68
„ 12 Mica-gneisses (p. 468), . . . . .	4.24	2.99
„ 4 Amphibole-gneisses (p. 484), . . . . .	3.14	5.13
„ 6 Pyroxene and Augite-gneisses (p. 486),	2.63	2.66
„ 13 Hälfelinte-gneisses (p. 493), . . . . .	2.18	2.68
„ 10 Amphibolites (p. 515), . . . . .	2.02	3.96
„ 6 Eklogites (p. 520), . . . . .	0.35	1.85
Mean of metamorphic eruptive rocks,	3.00	2.99
Mean of all, . . . . .	3.06	3.72

With reference to the last division of rocks—the metamorphic eruptives—Rosenbusch admits the old standing difficulty of distinguishing between the altered sediments and the altered eruptives. Thus Gneisses derivable from sediments give just such chemical proportions as appear in those referred to eruptive origin. There exists no sure criterion for classing a Gneiss according to its origin (p. 472, *loc. cit.*).

This is a well-known difficulty, and has been the subject of much research and speculation. We dare not do more than suggest here that in doubtful cases the general law of the alkali ratios of eruptives and sedimentaries, where this admits of application, should carry weight with petrologists.

The uncertainty referred to may, of course, affect the estimated composition of the crust-rock and of the siliceous sedimentaries. Examination will, however, show that the uncertainty being confined to a couple of groups only, can probably affect the final averages but little in either case.

We may now refer to a similar table of the sedimentaries: still deriving our figures as averages calculated from Rosenbusch's work:—

	K <sub>2</sub> O.	Na <sub>2</sub> O.
Mean of 16 Sandstones, Quartzites, and Greywackes (p. 391),	1·56	0·92
„ 12 Clays and Shales (p. 420), . . . . .	1·71	0·48
„ 17 Clay-slates (p. 425), . . . . .	2·68	1·19
„ 6 Calcareous Clay-slates and Whet-stones (p. 428),	2·69	0·98
„ 16 Phyllite-schists, or Clay-mica-schists (p. 437), .	3·52	1·53
„ 10 Schists (Sericite, Ottrelite, Chlorite, &c.) (p. 436),	2·36	1·04
„ 13 'Pelit-gneisse' (Phyllite-gneisses) (p. 470), .	3·18	1·69
„ 8 'Psammit-gneisse' (Sandstone-gneisses) (p. 471),	1·95	2·13
„ 3 Amphibole-gneisses (p. 484), . . . . .	1·44	2·65
„ 4 Mica-schists (p. 497), . . . . .	3·85	2·07
Mean of sedimentaries, . . . . .	2·49	1·47

We may observe further that the averages afforded by the valuable collection of analysis of American rocks, compiled by Messrs. Clarke & Hillebrand, will be found to confirm these results.\*

For the original crust, Clarke's alkali ratio works out—

$$\frac{\text{Na}_2\text{O}}{\text{K}_2\text{O}} = \frac{1\cdot29}{1},$$

and Rosenbusch's,

$$\frac{\text{Na}_2\text{O}}{\text{K}_2\text{O}} = \frac{1\cdot22}{1}.$$

On the other hand Rosenbusch's sedimentary rocks show that

$$\frac{\text{Na}_2\text{O}}{\text{K}_2\text{O}} = \frac{0\cdot59}{1}$$

When it is remembered that, age by age, those sediments were being deposited, some directly from the parent igneous rocks, and others by denudation of former sediments, the great importance to the present hypothesis of this broad difference in the alkali ratios, and in the absolute amounts of sodium and potash in the original and derived rocks, must be evident.

If now the inference is right that the missing alkalis were supplied to the ocean, we should expect to find on a rough approximation of the bulk of sedimentaries, and hence of the original rocks giving rise to them, that such a mass of parent rock would be adequate to supply the sodium in the ocean. And this is actually the case; we find, in fact, that the estimated amount of sedimentary strata would,

\* U. S. Geol. Survey. Bulletin No. 148, 1897.

in its formation, be adequate to yield to the ocean the sodium that is in it, assuming these sedimentaries to be derived from rocks having the mean composition of the important eruptive masses now known. Even more, the result of the calculation indicates that what is in the ocean is not quite a full measure of the sodium washed from these rocks. Recollecting that the stratified Rock Salt—the former inland-sea deposits—should enter the estimate on the side of the amount credited to the ocean, the result must be regarded as satisfactorily favouring the hypothesis. The restoration of the potash is attended with difficulties to be referred to later which render such a satisfactory result impossible.

For an estimate of the amount of sedimentary rocks on the Earth's surface we are indebted to Mr. T. Mellard Reade.\* For the average thickness of sedimentary rocks down to the base of the Cambrian, Mr. Reade takes a volume equal to the land area covered to the depth of one mile: this being based on the results of borings, sections, &c. This commends itself as a good approximation. He further, however, assumes that a similar volume of sediment exists under the sea. The latter assumption is probably excessive, even if it includes the relatively small additional amount of dissolved matter in the ocean. Pre-Cambrian sedimentary rocks are so comparatively limited in amount that the inclusion even of these, as defined by our present knowledge, can hardly justify the total of the estimate. However, we will provisionally accept it, and carry out our calculation applied to the mass so defined.

Mr. Reade† estimates 10 per cent. of the land sediments to consist of calcareous rocks, and also that the total mass of calcareous rocks of the Earth would suffice to cover its surface to a depth of one-tenth of a mile. To arrive at the amount of siliceous detrital sediments from these estimates, we must deduct from his estimate of the total sedimentaries such a mass of calcareous rocks as would cover the Earth to a depth of one-tenth of a mile, and further make an allowance for precipitated materials other than calcareous. Neglecting the last deduction as being a comparatively small one, we find that the deduction of the calcareous rocks leaves his estimate of rocks other than calcareous to amount to a layer 1.6 of a mile in thickness over the land-area of the Earth. Hence the mass in tons is equal to  $558 \times 10^5 \times 1.6 \times 2.5 \times 42 \times 10^3$ , or  $94 \times 10^{16}$  tons nearly. The value  $558 \times 10^5$  is the area of the layer in square miles, 1.6 its thickness in miles, 2.5 the assumed specific gravity of the rock, and  $42 \times 10^3$  the mass in tons of a cubic mile of water. The mean soda of the more abundant sedimentaries amounts, as we have seen, to 1.47 per cent. Hence  $13.8 \times 10^{15}$  tons of soda exist in this mass of detrital sedimentary rocks. To this must be added the known amount of soda in the sea, which is obtained by converting  $15,627 \times 10^{12}$  tons of the chloride to the oxide; giving  $21 \times 10^{15}$  tons.

\* *Geol. Mag.*, vol. x., 1893, p. 97.

† *Geol. Mag.*, vol. vi., 1879, and *Proc. Roy. Soc.*, vol. xxviii., 1879, p. 281.

The restoration of this to the rocks therefore raises their amount of  $\text{Na}_2\text{O}$  to  $34.8 \times 10^{15}$  tons.

The total bulk of sedimentary rock, on Mr. Reade's estimate, is however equal to a layer two miles deep over the dry land.\* This amounts to  $116 \times 10^{16}$  tons: hence, with the sodium of the ocean restored to them, we find the soda percentage from the fraction  $\frac{3.48}{116}$ , which is 3.00 per cent. This is about the soda percentage of many Granites, Gneisses, and Diorites, &c., but falls somewhat short of the average of the eruptive and igneous rocks. The stratified salt deposits would somewhat raise the figure to over 3 per cent. Clarke's average original crust has 3.61 per cent.

It appears very probable that we may in part trace the deficiency to the estimate of sedimentary rock beneath the ocean. This must be mainly precipitated material; the detrital deposits can only be a fraction of that upon the land. We can easily see how an estimate on somewhat different and, it is submitted, more satisfactory bases may be effected, bringing almost exact agreement between the restored sediments and the primal rock.

We can use the broad fact—to be presently shown—that the comparison of disintegrated and decomposed rock material of the present day, constituting soils of various rock-formation, reveals a loss of constituents of parent rock amounting on the average to 38 per cent. When it is remembered that such soils represent in many cases, extreme stages of weathering never attained to by many sediments, but that these latter are often the result of little more than disintegration and transportation, it appears probable that 30 per cent. may be assumed as the loss by solution of the entire detrital sediments. We accept one mile deep of these on the land, and, confining ourselves to purely detrital siliceous sediments, assume that as much as 10 per cent. of what is on the land is in the sea, or, say, a total of 1.1 mile deep over the land area. We include in this the Pre-Cambrian detrital sediments.

To recover from this the original mass of parent rock, we assume that a loss of 30 per cent by solution occurred in the process of denudation, or in other words, the 1.1 mile of detrital sediments is 70 per cent. of the original mass of parent rock. The mass of 1.1 mile deep of sedimentary rock of specific gravity of 2.5 will be  $64 \times 10^{16}$  tons. This being assumed as 70 per cent. of the original mass, the latter is  $91 \times 10^{16}$  tons.

\* In stating that there is as much sedimentary rock under the sea as upon the land, Mr. Reade possibly implies that the submarine sediments are to be estimated as possessing a *thickness* of one mile. Mr. Reade's calculation of the geological age of the Earth on the rate of denudation of the sediments appears, however, to involve that the *bulk* of sedimentary material beneath the ocean is, in his opinion, to be taken as about equal to what is upon the land, or the total bulk is equal to the land-area covered to a thickness of two miles. Geol. Mag., Dec. 3, vol. x., pp. 97-100.



The mass of  $64 \times 10^{16}$  tons contains  $940 \times 10^{13}$  tons of  $\text{Na}_2\text{O}$ . Adding the amount in the ocean ( $21 \times 10^{15}$  tons), we obtain  $30.4 \times 10^{15}$  tons. This restored to the original mass of  $91 \times 10^{16}$  tons gives a percentage of 3.34.

It may be independently shown that the soda ratio of the original rock to that of the sedimentaries supports the view that 30 per cent. must have been about the loss, by solution, of the original rock. We assume that the sedimentaries are derived from an original rock, such as Clarke arrived at, but we assume no more.

To see this, we have to refer again to Mr. Merrill's valuable book,\* which gives a useful collection of analyses of rocks and their derived soils.

Omitting a few cases, *i. e.* a Phonolite containing a soda-zeolite giving exceptional results on weathering, an incompletely recorded Basalt, and a Soapstone, his examples give the following results:—

	Percentage loss of entire rock revealed in the residual soil.	Percentage of each constituent lost.	
		$\text{Na}_2\text{O}$ .	$\text{K}_2\text{O}$ .
Granite (p. 209), . .	13.47	28.62	31.98
Gneiss (p. 215), . .	44.67	95.03	85.52
Syenite (p. 216), . .	56.28	97.11	81.85
Diabase (p. 221), . .	14.93	12.83	29.15
„ (p. 222), . .	39.51	95.37	45.88
Basalt (p. 223), . .	60.12	74.41	83.34
Diorite (p. 225), . .	37.51	84.87	38.75
Mean, . .	38.0	69.7	56.3

This indicates that, if at this stage of weathering, these soils were removed, redeposited, and reconsolidated, the mass of the parent rock would have been correctly estimated, on the basis that the mass removed in solution formed but thirty-eight per cent. of the original rock. At this stage of weathering we see that 69.7 per cent. of the original soda was removed.

If we assume that the loss of the soda bears to the loss of the entire rock a constant ratio—and with the exception of the first quoted Diabase this appears supported by the individual examples—we can apply to the mean analysis of the sedimentaries on the one hand, and to that of the mean original crust on the other, to arrive at a rough estimate of the loss of entire rock by solution in the process of formation of the former.

We find that (*ante*) 3.61 per cent. of  $\text{Na}_2\text{O}$  in the crust is represented by 1.47 per cent. in the sediment. From these figures we can calculate the amounts of this constituent lost and saved. To effect this accurately we must suppose some

\* "Treatise on Rocks, Rock Weathering, and Soils." Macmillan, 1897.

one constituent to pass over without loss from the one rock to the other, and use its percentage as a standard of reference by which to compare the loss of alkalis. We take the alumina for this purpose.

The alumina of the original rock in Clarke's average of analysis is 15·38. This is for the parent rock. For the derived rocks we may refer to Rosenbusch's tables (*loc. cit.*), where we find a mean of 16·06 per cent. of  $\text{Al}_2\text{O}_3$ , in the several groups of Slates, Sandstones, Phyllites, Schists, and Gneisses already referred to.\* We now have the data required for our calculation. On these we find, closely :—

$$\begin{aligned} \text{Na}_2\text{O lost} &= 60 \text{ per cent.} \\ \text{,, saved} &= 40 \text{ ,,} \end{aligned}$$

Referring now to the mean loss of soda and of entire rock given in soil-formations, we find that on the same ratio of sodium loss to gross loss, Clarke's original crust-rock should have lost 33 per cent. in affording sediments of the present soda percentage.

If, following this estimate exactly, we assume that the loss by solution in the process of denudation and formation of the detrital siliceous sediments had been 33 per cent. about, and still assuming 1·1 mile as the thickness of the detrital sedimentary mass spread over the land, the mass of the parent rock would calculate out as  $95 \times 10^{16}$  tons, and the restored soda would amount to 3·21 per cent.

*Hence it appears that, if a thickness of 1·1 mile of rock spread over the land area represents the bulk of the entire detrital siliceous sedimentary rocks, inclusive of submarine detritus, and this constitutes 67 per cent. of the entire sedimentaries of the Earth, including matter in solution in the sea, the sodium contained in the sea, added to what is left over in the detrital sediments, would suffice to restore to the entire mass a soda percentage almost equal to that in the eruptive, igneous, and crystalline rocks; the deficiency, about 0·4 per cent., exists partly in Rock Salt deposits. Some of the calcareous rocks,*

\* As follows :—

Mean of 15 Sandstones, &c. (p. 391), . . .	9·34
,, 13 Clays, &c. (p. 420), . . .	19·46
,, 18 Clay-slates, &c. (p. 425), . . .	17·91
,, 6 Calcareous Clay-slates (p. 428), . . .	14·95
,, 20 Phyllites (p. 433), . . .	20·85
,, 10 Sericite-schists (p. 436), . . .	21·62
,, 4 doubtful Phyllites (p. 436), . . .	15·42
,, 13 "Pelit-gneisse" (p. 470) . . .	18·98
,, 8 "Psammit-gneisse" (p. 471), . . .	11·93
,, 3 Amphibole-gneisses (p. 484), . . .	13·54
,, 6 Pyroxen-gneisses (p. 486), . . .	14·93
,, 4 Mica-schists (p. 497), . . .	13·82
Mean of all, . . .	16·06

also, possess an appreciable percentage of alkalis, which has been left out of account in the foregoing estimate of the soda contents of the sedimentaries.

## VI.—The Potash of the Rivers.

The matters referred to in the last section lead to the consideration of an objection—which may be urged against the present thesis—on the inconsistent relations of the alkalis, as estimated in the rivers and in the ocean, an objection which has led to the inference that the river-discharge of to-day must be different in its chemical nature from what it was in the past. We hope to show that this conclusion is arrived at without consideration of the whole facts, and that in truth the record of the rocks is best to be explained by assuming that this river supply was maintained in the past.

The potassium in the ocean, on the most reliable estimate of the mass of the latter, amounts to  $565 \times 10^{12}$ , tons; converted to  $K_2O$ , this becomes  $683 \times 10^{12}$  tons. The mass of  $Na_2O$  in the sea is  $21 \times 10^{15}$  tons. This is a ratio of 1 to 31 nearly.

On the other hand, the annual river-discharge of  $K_2O$  is  $7.3 \times 10^7$ , and the soda-discharge about  $21 \times 10^7$ , or a ratio of about 1 to 2.8. We must then suppose that the rivers are now supplying more potash relatively to soda than formerly, or that some process of abstraction of the potash from the ocean is in continual progress. Before considering the last alternative, we will examine the first to determine if such an explanation will clear away the difficulty.

A deficiency merely due to the river-supply having increased in recent periods should not interfere with effecting such a restoration of the potash percentage of the sedimentary detrital rocks as we effected in the case of the soda. Let us see if we can effect such a restoration. We take the most probable estimate of the sedimentary rocks and that most favourable to the restoration.

This afforded  $64 \times 10^{16}$  tons of detrital rock, and  $91 \times 10^{16}$  tons as the mass of the parent rock. The potash percentage obtained from Rosenbusch's tables of sedimentary rocks amounted to 2.49. Hence we find  $1.594 \times 10^{16}$  tons of  $K_2O$  in the detrital rocks, and adding  $663 \times 10^{12}$  tons contained in the sea we get  $1.66 \times 10^{16}$ . This, on the total mass of  $91 \times 10^{16}$ , is 1.82 per cent. But from Clarke's estimate of the chemical composition of the original crust this should be 2.83, or about 1 per cent. of the potash is missing. On this same estimate of the sedimentary rocks the soda percentage comes out correct within 0.4 per cent., and for that we have the great deposits of Rock Salt as a partial set off.

It is apparent, therefore, that the actual amount in the ocean disagrees with the indications of the rocks, and in the same direction—that of deficiency—as it does with the indications of the rivers.

The missing potash, if we assume the deficiency to be 1 per cent., would amount to  $91 \times 10^{14}$  tons. Assume that this is contained in the oceanic precipitates now forming the ocean floor, and add it to the  $K_2O$  now in solution in the ocean, or, more accurately, what is calculated on the amount of the chloride, the total is  $968 \times 10^{13}$  tons. Compare this now with the sodium of the ocean calculated as soda, and amounting to  $2100 \times 10^{13}$ , and we have a ratio of 1 to 2·2. Had we assumed 0·8 as the missing percentage of potash, allowing such a deficiency as exists in the case of the soda to be accounted for by Glauconite and other marine deposits of the land, and estimating that the deficient 0·8 per cent. existed now in the sub-oceanic deposits, we find in the sea and its deposits  $796 \times 10^{13}$  tons. This bears to the soda the ratio of 1 : 2·7, which fairly well agrees with the ratio obtaining in the alkalis of the rivers.

From these figures we see that *the deficiency indicated by the rocks is quite adequate to justify the supposition that the present alkali ratio of the rivers existed in the past.* To suppose the river-supply still less in the past is to make the record of the sedimentary rocks still more astray ; or, from another point of view, the record of the sedimentary rocks—if we accept the same data as agreed with the facts with regard to soda alkali—suggest that the rivers of the past must have discharged an equal, or even greater, amount of potash than at present.

We may put the matter again in another way, which brings out more clearly the true nature of the evidence:—The ratio of the potash to the soda in the rivers, if preserved throughout the history of denudation, would account for the alkali relations of the primitive and the derived rocks. This is independent of our estimate of Geological Time. The argument is, in fact, mainly directed against any assertion that the relative amounts of the alkalis supplied by the rivers of to-day is at variance with their probable past supplies.

If this ratio has varied seriously in the long past, then a difficulty not easily surmounted has to be faced. The difficulty may be put thus:—The mean potash percentages of the parent and of the derived rocks are determinable, and the difference represents a certain amount of potash which may be considered, within limits, *known.* This must have been removed from the parent rocks in some manner. If not by denudation, then in what manner? The fact that we cannot estimate it in the sediments or in the sub-oceanic deposits appears legitimately referable to our ignorance. The assumption that the rivers supplied less potash in the past leaves the revelation of the rocks inexplicable. The assumption is made in order to explain what is really a hypothetical deficiency (that of the potassium in the oceanic reservoir), and renders inexplicable an actual known deficiency (that of the potassium in the rocks).

The argument thus supports our Uniformitarian views by overbearing an objection often urged against the uniform supply of the constituents of the rivers.

This brings us face to face with the question as to where and in what form this missing potash is to be sought.

The Glauconite deposits of the deep-sea boundaries and the stratified marine sediments undoubtedly must be chiefly made responsible. The composition of this substance is given in the Report on the Deep Sea Deposits of the "Challenger" Expedition, where it is shown that it contains from 2.52 to 4.21 per cent. of potash derived from the sea-water. It may amount to 50 per cent. or 60 per cent. of the shallower deposits, or even more. The percentage of soda is from  $\frac{1}{3}$  to  $\frac{1}{17}$  of the potash, and therefore will hardly enter into consideration in this paper.

The formation of this substance appears dependent on the condition that the organic matter in the chambers of Foraminifera should reach the bottom, which, if so, will perhaps account for the absence of this body from the deeper deposits. The organic matter "transforms the iron in the mud into sulphide, which may be oxidised into hydrate, sulphur being at the same time liberated: this sulphur would become oxidised into sulphuric acid, which would decompose the fine clay," (terrigenous débris), "setting free colloid silica, alumina being removed in solution; thus we have colloid silica and hydrated oxide of iron in a condition most suitable for their combination." "There is always a tendency for potash to accumulate in the hydrated silicate formed in this way, and, as we have stated before, this potash must have been derived from the sea-water."\*

The following extract (page 384) will serve to show the opinions of the authors (Sir J. Murray and Professor Renard) on the widespread nature of this deposit:—

"It has already been stated that glauconite is one of the minerals most widely distributed in sedimentary rocks. It is found in the primary formations of Russia and Sweden among sands and gravels, in the Cambrian sandstone of North America, in the Quebec Group of Canada, and in the coarse Silurian sands of Bohemia. In the secondary formations its presence is more pronounced; for example, in the Lias, and especially in the middle and upper layers of the Jurassic system in Russia, in Franconia, in Swabia, and in England. It has a still greater development in the sands, marls, and chalks of the Cretaceous formation. It will suffice to recall the glauconitic rocks of the Neocomian, of the Gault, and of the Cenomanian in various regions, such as the glauconitic marls of France, Germany, England, and several parts of North America. The abundance of glauconite is continued into the Tertiary formations, from the lowest up to the highest horizons of the series.

"From this rapid enumeration, it is seen that glauconite traverses the whole of the geological periods, and its formation is continued in modern deposits along many continental shores, explored by the 'Challenger' and other expeditions."

\* Report, p. 389.

The analyses show that the mineral may vary in composition. "All that can be said is that the glauconite now forming at the bottom of the sea is, like the glauconite of geological formations, a hydrous silicate of potash and of ferric oxide, containing always variable quantities of alumina, ferrous oxide, magnesia, and often lime" (p. 386).

Merrill gives analyses, showing that the glauconitic marls of New Jersey contain up to 7 per cent. of potash, and remarks on the extent of such beds in the Cretaceous formation of New Jersey.\*

Potash is also taken up by organisms in the sea, more especially by the seaweeds. A very considerable amount must exist in the immense masses of vegetation in the shallower waters of the sea.

There is further a very interesting manner in which potash is abstracted from the sea, and returned to the land, which must, in its extension over Geological Time, have served to return immense quantities to the soils of coastal regions. This is by means of rain-water.

In Dr. Angus Smith's work on "Air and Rain" it is recorded that, near Caen in France, it has been estimated (by M. J. Pierre), that a hectare of land annually receives from the atmosphere, by means of rain, 8.2 kilogrammes of KCl, and 8.0 kilogrammes of  $K_2SO_4$ , amounting to a total of 7.9 kilogrammes of potassium. This is 1.23 tons of potassium per square mile per annum, or 1.48 tons of  $K_2O$ .

Now it is a well-known fact that, whereas sodium salts so brought to the land, are again freely yielded up by the soils, potash salts are retained. Vegetation also requires these salts as an essential constituent, sodium salts are not essential to vegetation.†

In connexion with this, the relative losses of the alkalies as shown in the table (*ante*), compiled from Mr. Merrill's work on "Rock Weathering" should be considered. It appears from that table that the average loss of potash, in the soils taken as examples, was 56.3 per cent., the soda loss being 69.7. According to this, the rivers are not carrying sufficient potash into the sea relatively to soda to account for what is going on under the decomposing effects of subaerial agencies.

We can see, too, that the revelations of the soil analyses are at variance with the broad facts of rock-chemistry to which we have been frequently referring. Thus, if we effect for potash a similar calculation to that carried out for soda, and estimate from the average potash percentages in the sedimentary detrital rocks, and of the primary crust-rock, the amount of potash lost and saved (assuming as before the alumina as the constant factor), we find the  $K_2O$  lost to be 15 per

\* *Loc. cit.*, p. 134.

† See Roscoe's and Schorlemmer's Chemistry, II., Part I., p. 57; also Mendeleeff's Chemistry, 1897, I., p. 546.

cent., and the  $K_2O$  saved to be 85 per cent., which is evidently at variance with the soil analysis.

The discordance appears to be set at rest in the light of what we have already stated regarding the retention of potash in soils, recollecting that the surface soil will be poorest in potash, whether by loss to vegetation, or by leaching out of soluble salts retained in the deeper lying parts. The matter is stated as follows by Mendeleeff\* :—

“The primary rocks contain an almost equal proportion of potassium and sodium. But in sea-water, the compounds of the latter metal predominate. It may be asked, what became of the compounds of potassium in the disintegration of the primary rocks, if so small a quantity went to the sea-water ?

“They remained with the other products of the decomposition of the primary rocks. When Granite or any other similar rock-formation is disintegrated, there are formed, besides the soluble substances, also insoluble substances—sand and finely divided clay, containing water, alumina, and silica. This clay is carried away by the water, and is then deposited in strata. It, and especially its admixture with vegetable remains, retains compounds of potassium in a greater quantity than those of sodium. This has been proved with absolute certainty to be the case, and is due to the *absorptive power of the soil*. If a dilute solution of a potassium compound be filtered through common mould used for growing plants, containing clay and the remains of vegetable decomposition, this mould will be found to have retained a somewhat considerable percentage of the potassium compounds. If a salt of potassium be taken then during the filtration, an equivalent quantity of a salt of calcium—which is also found as a rule in soils—is set free. Such a process of filtration through finely divided earthy substances proceeds in nature, and the compounds of potassium are everywhere retained by the friable earth in considerable quantities. This explains the presence of so small an amount of potassium salts in the waters of rivers, lakes, streams, and oceans, where the lime and soda have accumulated.”

This “*absorptive power of the soil*,” according to Professor Hilgard,† is more displayed in arid than in humid regions.

The conclusion of the whole matter appears to be that, whereas the sodium compounds tend to accumulate in the waters of the ocean, the potassium compounds tend to be stored in the solid form or retained upon the land; and that to the causes which bring about this separation, and not to any differences in part processes of denudation, the remarkable scarcity in the ocean of potassium relatively to sodium is to be ascribed.‡

\* *Loc. cit.*, Vol. I., p. 546, 547.

† Quoted by Merrill. Treatise on “Rocks, Rock Weathering, and Soils,” pp. 369-370.

‡ The Palagonite coating on basic volcanic glass—apparently derived by a hydration and alteration of

## VII.—Uniformity of Denudation by Solution.

*Land area and Rainfall.*—The most prominent considerations involved in the question of how far the present rate of denudation by solution may be accepted as an average of that extending over past times are that of the varying ratios of land and sea areas of the past and the amount of rainfall received upon the latter. The fact that palæontologically similar deposits in the various parts of the world are not necessarily contemporaneous, but homotaxial, debars the geologist from mapping the sediments of any horizon (even were these fully known) as forming part simultaneously of the oceanic area. Could he even claim full assurance here, the land areas supplying the sediments must still remain unknown.

In this difficulty indirect inferences only can be resorted to.

Those who accept the stability of the continents and oceans as a whole cannot well admit that the balance of land and water was ever very seriously interfered with. Sir J. Murray\* has calculated that if the present land of the globe were reduced to the sea level by being removed to and piled up in the shallow waters of the ocean, its extent would be altered from the present  $55 \times 10^6$  to  $80 \times 10^6$  square miles, the ocean simultaneously changing from  $137.2 \times 10^6$  to  $113 \times 10^6$  square miles. The mean height of the land, which is at present 2250 feet, would become 0; while the mean depth of the ocean, at present 2080 fathoms, would increase to 3 miles,  $23.45 \times 10^6$  cubic miles of material being transported into the sea.

If the Earth's crust were rigid, and neither subsidence or elevation ever took place, such a calculation would mark the extreme distribution of the existing sub-aerial material which would be possible under the action of denuding agencies. It could only be brought about by an infinitely prolonged denudation and quiescence of the crust.

As a matter of fact, however, we know that over the continental areas there have been frequent depressions and elevations, and these acting alternately again and again over the same area. The Uniformitarian, we assume, regards this shifting balance of land and water as confined mainly to the area indicated above, the 80 million square miles marking out the elevated plateaux of the globe. The dry land of to-day occupies some 68 per cent. of this area. It cannot be supposed to have ever occupied 100 per cent. of it, for then sediments must have been laid down in the present ocean troughs. That such sedimentation, again, as

the glass, and the taking up of a small additional amount of potash and soda (apparently from the sea)—is hardly sufficiently abundant, according to present knowledge, to justify consideration here. See the Report on the Deposits, p. 304. The Phillipsite appears to be a purely alteration product of the basic *débris*. See Merrill (*loc. cit.*, p. 375).

\* Scottish Geological Magazine, 1888, pp. 1 *et seq.*



we see in the great formations could have been effected without large areas of exposed land is impossible. These rocks infallibly assert the existence of dry land proportional to their own magnitude and complimentary to their own submergence. The sedimentary deposits themselves suggest, then, from the necessities of their supply, a limit on the other side, that is, to the reduction of land area in past times.\*

The conditions of sub-aerial denudation of the present suggest considerable latitude within which the ratio of land to water may vary without affecting the denudation to the ocean. This is shown in the fact that the present amount of rainfall on the land is not sufficient to denude more than four-fifths of its area into the sea. The rainless regions of the Earth are estimated by Sir J. Murray to amount to  $12.2 \times 10^6$  square miles.† Over these regions the rainfall is less than 10 inches, and is re-evaporated without reaching the sea. If the land area were diminished by this number of square miles, the effect on the supply to the ocean would probably be but small. If, on the other hand, it increased beyond its present extent, the rainless area would also most probably increase; but the denudation to the ocean would probably again be only effected in a comparatively small degree. In the extreme case of the entire land plateau being occupied by dry land, the disturbance of balance might so far effect the amount evaporated from the oceans as to diminish the land denudation.

Many causes act to influence the rainfall on the Earth. The larger ones, as we have seen, will hardly act to produce great variations. The smaller we cannot suppose, reasonably, will always conspire to act one way. We have already referred to the fact that, if the non-oceanic origin of the Rock Salt beds be accepted, these deposits point to just such rainless regions in the past as now exist. The most cautious conclusion, we submit, must be that the facts of Earth-history over Geological Time, as we know them, do not point to any great or long-continued changes in the conditions of sub-aerial denudation.‡

\* See Wallace's "Island Life," chap. vi. See also Green's "Physical Geology," 1892, p. 687, *et seq.*, and "Three Cruises of the Blake," by A. Agassiz, 1888, pp. 126 and 166. The question of the permanence of continents and oceans has been so much discussed that further reference here is unnecessary.

† Assuming that over areas with less than 20 inches rainfall there is complete re-evaporation, only 36,697,400 square miles actually drain into the sea. *Loc. cit.*

‡ [Note added in the Press.] The possibilities of Sun-history, however, enter the question. Prof. Perry (*Nature*, July, 13, 1899, p. 247), states it as his belief (in reference to Prof. Newcomb's view that sun-heat can have varied but little during Palaeozoic time), that there may have been millions of years, during which the sun may have been radiating at only one-third or one-tenth, of its present rate. This would of course lead to diminished meteorological activity generally, although the denudative effects due to ice might increase. Those who hold that in the past there was much increased denudative activity should bear the possibility referred to by Prof. Perry in mind.

*Chemical Denudation.*—Quite another factor in the uniformity of solvent denudation is the chemical and physical nature of the rock surfaces and soils exposed during the successive ages of the Earth's history. With reference to the view that in earlier times larger areas of igneous rocks were exposed to denudation than in more modern periods, some remarks on soil and weathering are necessary.

We see in soil-formation of the present day a process of ever deepening disintegration of the parent rock, and simultaneously progressing decomposition of the upper layers. This results in a surface layer, possessing a reduced percentage of the more soluble materials, which protects the richer material beneath. If the rock itself is for physical or chemical reasons highly resisting, the leaching out of soluble materials from the surface layer must ultimately progress further for a given advance of disintegration than if the rock rapidly yields to the actions tending to disintegrate it.

In the surface layer the rain charged with carbonic and humic acids principally exerts its effects, the more soluble constituents yielding of course before the less soluble, and so growing finer in grain as time progresses. The more soluble substances thus become concentrated in the finer constituents of the soil.\*

Ultimately, if mechanically transported to the rivers, a sorting according to mass and dimensions occurs. The finer grained particles are carried on a current which drops the coarser particles. Thus the finer silts are richest in the soluble constituents of the former soils. They constitute material on which vegetation flourishes; and if deposited in the ocean, build up rock-masses rich in alkalies, chiefly—as we have seen—in potash. Nearer the shore, the coarse grits and sandstones, poor in alkalies, accumulate.

Subsequent upheaval brings to the surface rocks, of which the finer-grained and softer varieties are those possessing the larger share of alkalies. These generally, owing to secondary or, in some cases, primary mica, and their fineness of grain, are most distinctly cleavable. Such Slates contain from 3 to 5 per cent. of alkalies.

The dissolved materials pass through a different history, but in the limestones, &c., to which they give rise, most generally there exists an amount of detrital felspathic matter sufficient, when again uplifted and weathered, to yield soils scarcely less rich in alkalies than those derived directly from the parent rock.

This last fact is one of great interest. Merrill shows that soils derived as

\* See "Rocks, Rock-weathering, and Soils," pp. 365, 366, where this is proved by mechanical and chemical analysis.

residual material from the most diverse rocks are very similar in composition.

The full tables should be consulted.\*

	K <sub>2</sub> O.	Na <sub>2</sub> O.
Residual soil from Limestone, Wisconsin, 4·5 feet from surface,	1·61	2·19
Same, 8½ feet from surface, . . . . .	0·93	0·80
Residual soil from Limestone, Wisconsin, 3 feet from surface,	0·83	1·45
Same, 4½ feet from surface, . . . . .	1·60	1·37
From Dolomite, Alabama, . . . . .	2·32	0·17
From Diabase dike, N. Carolina, . . . . .	trace.	trace.
A Gabbro-soil, Maryland, . . . . .	0·86	0·40
Subsoil from Trenton Limestone, Maryland, . . . . .	4·41	0·29
Soil from Triassic Sandstone, Maryland, . . . . .	4·03	0·79
Trenton Limestone, unaltered, . . . . .	not det.	not det.
Residual soil from same, . . . . .	2·50	1·20
Gneiss, Virginia, . . . . .	4·25	2·42
Soil from same, . . . . .	1·10	0·22
Diorite, Virginia, . . . . .	0·55	2·56
Soil from same, . . . . .	0·45	0·56

In the above it appears that the soils derived from the igneous rocks—more especially the more basic ones—show a greater poverty in alkalis than those derived from Limestones and Sandstones. This probably arises, in part, from more soluble alkali constituents being present, but in many cases doubtless from a more resistant parent rock leading to the more complete weathering of the soil. On the other hand, the more soluble Limestones rapidly concentrate their siliceous materials to a soil rich in very fine felspathic and other particles.†

In short, the daily and yearly action of the weather upon such soils would not show a yield of alkali greater in the case of those residual from igneous rocks than from those residual from sedimentary rocks. The attack on the rock beneath must furnish a very minute supply of alkalis contrasted with what is proceeding from the soil. Merrill refers to a calculation in reference to one of the Trenton Limestone soils that, in every cubic foot of soil, “158,000 square feet of surface are exposed to the action of water and air as well as to the roots of growing plants.”‡

It is, too, a fact of common observation and comment, that igneous and eruptive rock masses are more slowly denuded than the majority of sedimentaries. Whether in regions of Limestone or Slate the higher and more abrupt surface features are generally the granitic or igneous masses; and this obtains

\* *Loc. cit.*, pp. 305, 306; also, pp. 358, 359.

† *Loc. cit.*, p. 307.

‡ *Loc. cit.*, p. 308.

although the weathering as dependent on chemical decomposition is most active on the eruptives.\* The effect is greatly physical in origin. "In stratified rocks there is, as a rule, a lack of homogeneity, certain layers being more porous than others, or containing mineral constituents more susceptible to the attacking forces."†

A full account of the conditions at work, so far as our present knowledge extends, appears in Merrill's work, already so frequently referred to.

The entire consideration shows that the greater richness in alkalies of the original igneous rocks is conjoined to such resistant physical properties as in the general case involves the more rapid turn over of the less rich sediments. The frequently greater richness of the residual soils of the latter is a consequence of this.

But apart from such considerations, have we any valid reason to expect in the past a more rapid solution of the rocks than progresses at the present day? Factors enter the question on each side. The denser atmosphere of carbonic anhydride which may have obtained in the Palæozoic epoch, and which would have contributed not only more carbonic acid to the rain, but by its great pressure have enabled this to take up a greater quantity, finds a set-off in the subsequent much greater development of vegetation. The humic and allied acids exert, as is now known, a powerful influence in promoting decomposition. "There is reason to believe that, in the decomposition effected by meteoric waters, and usually attributed mainly to carbonic acid, the initial stages of the attack are due to the powerful solvent capacities of the humus acids."‡ The mechanical action of the roots is also a very important factor. Now these effects of vegetation were probably absent during the Pre-Cambrian and early Palæozoic epochs. Indeed, *if* the dense atmosphere of carbon dioxide existed, its mere mechanical effects when urged to the speed of a gale would have sufficed to destroy any but lowly plants in sheltered positions.§

The carbonic anhydride of the atmosphere of to-day by no means corresponds in amount with that which effects the operations going on in the soils. The percentage of CO<sub>2</sub> in soils is far greater than in the air. The decay of vegetation is probably ultimately responsible for this increase. While the CO<sub>2</sub> in 10,000 parts by weight of the atmosphere may be about six, that in soils, rich in humus, may

\* Merrill, *loc. cit.*, p. 271. The familiar appearance of igneous dykes standing out like walls above surrounding sedimentary rocks is an example.

† *Loc. cit.*, p. 248.

‡ Geikie, "Text Book of Geology," 3rd edition, p. 472.

§ Possibly these mechanical effects may be accountable for the earlier forest vegetation possessing the morphological characters of that now clothing exposed and mountainous regions, rather than those of the leafy trees of our valleys and plains. Its habitat, moreover, appears to have been the marsh and the sunken place.

rise to 5.13 parts.\* This is the atmosphere actually concerned with the destruction of Felspars, &c.

The existing soils of a considerable part of the northern hemisphere are due to the glacial effects of older Quaternary times. However, in the loess of China, Europe, &c., the adobes of America, and similar clays, surface deposits are found which may well have been represented in the remote past. In these we find alkali percentages comparable with the sedimentary soils, the potash ranging from 1.03 to 2.13, the soda from 0.57 to 1.63. The state of comminution is also remarkable.†

The interesting evidence of Pre-Palæozoic granitic decay described by Dr. R. Bell of the Canadian Geological Survey, and referred to by Merrill,‡ should be referred to by those interested in the question, although, as not being of a quantitative nature, the evidence does not, save for its general teaching, concern us here. Other cases of evidence for Pre-Cambrian denudation are mentioned in the same treatise. Mr. Merrill concludes:—

“These, and other illustrations that might be given, point unmistakably to the identity of geological processes and correspondence in results since the earliest times, even did not analogy and the thousands of feet of secondary rocks furnish us safe criteria upon which to base our inferences.”

Approaching finally the question as to whether a correction on the Geological Age of the Earth previously arrived at is fairly due—according to our lights—on the score of the greater mass of detrital sediments now reposing on the land areas compared with those of the earliest times, we have, as we have seen in these very sediments, rocks of a physical character which forbids us to pronounce, in many cases, on the relative effectiveness of igneous and sedimentary rocks, as contributing to solvent denudation. We have also factors of both earlier and later times acting to accelerate solvent denudation. Of these, the least speculative is the influence of vegetation which is a post-Early-Palæozoic factor mainly. Again, the land uplifted from the primeval ocean, after the free acids were for the most part neutralised, was, we must infer, overlain with insoluble siliceous residues. To make any deduction or addition is not warranted. There appears no good reason to suspect that our broad Uniformitarian principles are leading us into considerable error where, more especially, such disturbing causes as we are compelled to recognize are both of positive and negative signs. But the whole consideration should undoubtedly lead us to widen the margin we allow for error in our estimate of Geological Time.

\* Merrill, *loc. cit.*, p. 178.

† Merrill, *loc. cit.*, p. 330.

‡ *Loc. cit.*, pp. 275, 276.

VIII.—**The Alkalies of Sediments and the Geological Age of the latter.**

A very interesting but difficult line of inquiry is suggested in the probable facts of geological denudation which we have reviewed.

If the detrital sedimentaries of more recent geological age are derived, or in part derived, from pre-existing sediments, we would anticipate that the detritals of successive periods should generally show diminishing alkali percentages. The inquiry is complicated by the necessity of observing that rocks of similar origin are in each case compared. The finer grained sediments will be, as we have seen, the richest in alkalies, for the reason that the more soluble constituents of soils are just those which are reduced to the finest dimensions. Hence when, in the course of time, the mechanical sorting of the river exerts such effects as the sieve of the investigator, the finer sediments laid down in sea or lake come to differ in their chemical nature from the coarser. Again, the percentage of soluble material in the soil may, as we have also seen, depend to some extent on the nature of the parent rock; and hence one soil may differ from another in the percentages of alkalies contained in the derived silts. However, by careful attention to the petrological and above all the physical character of the slates or clay slates we compare, some record of progressive change might be expected to be revealed.

Although our investigation labours under the difficulty that the existing records were not sought with a view to its prosecution, there are some broad indications of the evidence we seek, which we are justified in referring to.

Let us look at the analyses of the "Roofing-slates." In these a certain fineness of grain and attendant similarity of history are probably in most cases involved. These are types mainly of the finest sediments. It does not appear that we have any reason to suppose that their deposition, consolidation, and prolonged existence in the rocks added to or subtracted from their original chemical constituents. With these we may probably compare Clay Slates of more modern periods, and the finest muds now being laid down in estuaries and lakes.

Referring to Clarke and Hillebrand's collection of rock analyses,\* we find sixteen analyses of Roofing-slates of Cambrian age from Vermont and New York. The mean percentage of added potash and soda alkalies is 5.05. In Rosenbusch (*loc. cit.*, p. 425) the alkalies in a Welsh Roofing-slate are recorded as 5.38 per cent.; a Cambrian Clay Slate of the Fichtelgebirge, 5.53 per cent.; a Lower Silurian Clay Slate of the same region, 4.10 per cent.; and a Silurian Clay Slate from Christiania, 5.60 per cent. These are otherwise mutually fairly concordant in chemical composition, and also concordant with those from the United States.

\* Bulletin U.S. Geological Survey, No. 148, 1897.

The mean of all these affords 5·08 per cent. of alkalis—the potash in each case exceeding the soda.

In this same table of Rosenbusch's we find a Devonian Roofing-slate, Erdstollen, with 3·04 per cent. of alkalis. Three other Devonian Slates, not named as Roofing-slates (Nos. 2, 3, and 4), show a mean of 3·54 per cent.

In the Culm we find a Roofing-slate having 3·22 per cent. ; another Culm Roofing-slate 5·00 per cent. ; and an Upper Culm grey Clay Slate of the Fichtelgebirge, 2·99 per cent.

If we compare with these ancient sediments those now being deposited, we obtain the following figures :—Bischof records 1·47 per cent. of alkalis in the suspended matter carried down by the Rhine near Bonn.\* Although this is fast moving water, the general analyses otherwise closely resembles Roofing-slates and Clay Slates, as Bischof points out. The mud of the Nile, near Cairo, affords 1·96 per cent.† Merrill gives two analyses of fine muds washed by the sea into harbours and bays on the coast of North Carolina. They are fine, dark-coloured muds, brought down by the rivers and mixed with some decaying animal and vegetable matter. These contained 1·97 per cent. and 2·17 per cent. of alkalis ; or, deducting all organic matter and water (which are temporary constituents), these numbers rise to 2·37 and 2·39 per cent. The mean given by these four modern silts and muds is 2·05 per cent. of alkalis.

Without further investigation the facts recorded can only be advanced as suggestive.

### IX.—The Solvent Denudation of the Ocean.

This subject, of course, closely concerns the matter discussed in this Paper. To assume that no solvent action was exerted by sea-water upon the coasts, and the detrital remains continually being poured into it, would, of course, be erroneous. We can only hope, in the present state of our knowledge, to find some clue as to the magnitude of the time allowance justified by marine solvent denudation.

In the first place, it is to be noticed that this denudation must be progressing chiefly along the immediate coast-lines of the land areas. We can readily arrive at a rough estimate of the area involved. Measurement on a terrestrial globe shows that the coast-lines of the continents and principal islands amounts to  $132 \times 10^3$  miles.‡ Much of this is rock-bound. Along the rock-bound shores the rate of denudation, apart from attrition, is probably extremely slow. Soils cannot here accumulate. Particles removed by attrition are carried out and quickly laid

\* "Chemical and Physical Geology," p. 123.

† *Loc. cit.*, p. 133.

‡ Croll, allowing for bays and inlets and the smaller islands, estimates the coast line at  $116 \times 10^3$  miles. Wallace takes  $100 \times 10^3$  miles. See "Island Life," p. 221.

down in deep water. That the denudation here progressing is mainly mechanical is shown by the smooth surface of rock below water-line. Limestones bordering the sea are often deeply pitted by the solvent action of the weather above high-water mark; beneath this line all is polished smooth.\* Of course this does not show that no solution occurs. It merely connects the retreat and undercutting of sea-coasts with the scouring action of hard silt in the water.

A large part of the coastal lines of the Earth is, however, beach, where the waves are in perpetual motion and where the rounding of the larger stones more especially testify to the activity of erosive action. But making no allowance for rock-bound coasts as a set-off against the neglect of the minor indentation of the shore line, and supposing the active motion of the waves to extend for a distance of 1000 feet into the shallow water, we have an area of 25,000 square miles over which the sea is in active motion.

It is evident that even a very considerable rate of solution over this area would bear but a small proportion to that progressing over the forty-four millions of square miles exposed to chemical actions for a large part, far more active than is exerted by sea-water, and generally in material finer in grain.

This last point may be considered set at rest by the experiments of Daubrée. Enclosing three kilogrammes of felspar in fragments, along with water containing three per cent. of chloride of sodium, in the rotating cylinders used in his well-known experiments, and making all the conditions the same as those obtaining in his experiments in which fresh water was used, he could not obtain, either in a vessel of iron or of stone-ware, any alkaline reactions except the most feeble: "et incomparablement moindre que celle qui se manifeste dans l'eau distillée." The presence of the chloride of sodium appeared to arrest the decomposition.† To this inactive nature of sea-water the prolonged preservation of felspathic fragments on sea-beaches has been ascribed.

There is interesting evidence bearing in this direction, to be derived from the deep-sea deposits. The volcanic *débris*, whether wind or water borne, must be in a fine state of comminution in order to reach the central oceanic deposits.‡ Such particles must sink with extreme slowness through depths measured by miles. Their subsequent sojourn upon the bottom is of unknown duration. Yet it is remarkable that when these deposits are analysed the alkali ratio is that of the igneous, not that of the sedimentary rocks. This is a plain proof that the waters of the ocean do not affect them as would terrestrial rains and rivers.

Thus we find a deep-sea ooze from 5422 metres deep between New Zealand and Tahiti to contain 4.92 per cent. of  $\text{Na}_2\text{O}$ , and 2.82 per cent.  $\text{K}_2\text{O}$ . Another,

\* In the neighbourhood of Dublin—at Donabate—this is clearly shown.

† "Géologie Experimentale," 1., p. 275.

‡ See Wallace's "Darwinism," p. 363, for facts as to these dimensions.



from a depth of 4956 metres, west of the Society Islands, gave 1.83 per cent.  $\text{Na}_2\text{O}$ , and 1.74 per cent. of  $\text{K}_2\text{O}$ .\* In Murray and Renard's Report of the "Challenger" results, it is suggested that some of this volcanic *débris* may come from submarine sources. In any case the pumice and glass of the ocean floor, even when decomposed, retains its igneous alkali ratio. Thus andesitic pumice contained  $\text{Na}_2\text{O}$ , 2.34,  $\text{K}_2\text{O}$ , 1.61 per cent.; basaltic pumice,  $\text{Na}_2\text{O}$ , 2.81, and  $\text{K}_2\text{O}$ , 1.24 per cent. Other concordant examples are given.

Are we to make a correction for oceanic denudation? Are the solvent effects of a magnitude which would result in a noticeable fraction of our estimate of geological time being in excess? If we supposed that the solvent effect of the waves acting on the full coast line of the Earth were not less, not even equal, but 10 times as great as what is continuously progressing in an equal area of the soils, the disproportionality of areas reduces its present solvent effects to  $\frac{1}{177}$ th of the effectiveness of the land in supplying soluble materials to the sea. This would then be a correction of half a million of years on the time estimate.†

In the coastal effects of to-day, this correction would be almost certainly excessive. To these effects must be added those progressing on the immense quantities of fine silt which the rivers pour annually into the oceans, and which has been estimated by Sir J. Murray as 2.5 cubic miles of sediment. Much of this rapidly finds a quiet resting-place, and probably nearly perfect preservation near the coasts. The remainder, borne into deeper water, must yield something to the ocean. We have, as we have seen, evidence that this may not be much; possibly the half million years would more than cover the entire solvent effects of the ocean.

We have to consider, indeed, in this matter that the ocean was not always charged with its present dissolved salts. The primeval ocean, most probably after the free acids were satisfied in the solution of the silicates, carried chiefly chlorides indeed, but chlorides of lime, magnesia and other metals. The subsequent changes were those of replacement for the greater part. We have no reason, however, to suppose that these salts could act substantially differently from the chlorides of sodium now constituting the larger part of the chlorides.‡

We can only, from what we know, gather some idea of the order of magnitude of the correction for oceanic solvent-denudation. It appears almost certain that this cannot exceed a very few million years.

The allowances we felt justified in making in the earlier part of this paper left our estimate at eighty-nine millions of years. The least speculative part of our knowledge inclines us to believe that this is probably a major limit.§ Taking into

\* Rosenbusch, *loc. cit.*, p. 420.

† See also "Island Life," p. 225, foot note.

‡ A. Agassiz thinks the solvent power of the ocean during some of the earlier geological deposits was far less than during later times. See "Three Cruises of the Blake," I., p. 147.

§ See the Summary of positive and negative errors contained in Appendix II. and, more especially, set off 1 and 2 of the errors going to make the estimate a maximum against 1, among those tending to render it a minimum.

account our uncertainty in many particulars attending these corrections, and as to the constancy throughout the past of solvent denudation, and bearing in mind that any approximation to a correction for marine denudation must be attended with this same uncertainty, but that the latter correction will undoubtedly be subtractive, we think that it is at least justifiable to claim that *our present knowledge of solvent-denudation of the Earth's surface points to a period of between eighty and ninety millions of years having elapsed since water condensed upon the Earth, and rain and rivers and the actions continually progressing in the soils began to supply the ocean with materials dissolved from the rocks.*

## CORRIGENDA.

Pages 34 & 35—*Note in reference to the calculation respecting the neutralisation of free hydrochloric acid:—*

The effect of the aluminium should also be taken into account. This would reduce the estimated percentage of acid neutralised in the formation of sodium chloride, and so raise somewhat the estimate of geological time.

The margin of error assumed in the final estimate of geological time must, however, cover the oversight, but leaving the balance of probabilities in favour of a duration more nearly 90 than 80 millions of years.

Page 61, third line from top—*for Erdstollen read* Erbstollen.

Page 66, eighth line from top—*for part read* past.

APPENDIX I.

To facilitate review of the numerical quantities adopted in the calculations involving the Age of the Earth, the chief data are here collected.

Area of land (Murray and Wagner), . . . . .	55,814,000 square miles.
Ratio of oceanic to land-area, . . . . .	2·54 : 1.
Hence, oceanic area, . . . . .	141,767 × 10 <sup>3</sup> square miles.
Mean depth of ocean (Murray), . . . . .	2076 fathoms = 2·393 miles.
Bulk of ocean, . . . . .	339,248 × 10 <sup>3</sup> miles.
Mass of a cubic mile of sea-water, . . . . .	43 × 10 <sup>8</sup> tons.
Mass of ocean, . . . . .	1·460 × 10 <sup>18</sup> tons.
Mass of NaCl in ocean, . . . . .	39,782 × 10 <sup>12</sup> tons.
„ Na „ . . . . .	15,627 × 10 <sup>12</sup> tons.
„ Cl combined with Na in ocean, . . . . .	24,155 × 10 <sup>12</sup> tons.
„ K <sub>2</sub> SO <sub>4</sub> in ocean, . . . . .	1260 × 10 <sup>12</sup> tons.
„ K „ . . . . .	565 × 10 <sup>12</sup> tons.
„ MgCl <sub>2</sub> „ . . . . .	5568 × 10 <sup>12</sup> tons.
„ Cl combined with Mg in ocean, . . . . .	4161 × 10 <sup>12</sup> tons.
Annual river discharge into oceans, . . . . .	6524 cubic miles.
Mass of sodium in a cubic mile of river-water, . . . . .	24,106 tons.
Annual river supply of Na, . . . . .	15,727 × 10 <sup>4</sup> tons.
Annual (calculated) Na <sub>2</sub> O discharge of rivers, . . . . .	21 × 10 <sup>7</sup> tons.
„ „ K <sub>2</sub> O „ „ . . . . .	7·3 × 10 <sup>7</sup> tons.
Estimated bulk of siliceous sedimentary detrital rock = layer 1·1 mile thick over land.	
Soda percentage of primitive rock, . . . . .	3·61.
Potash „ „ „ . . . . .	2·83.
Mean soda percentage of sedimentaries, . . . . .	1·47.
„ potash „ „ . . . . .	2·49.

## APPENDIX II.

The errors possibly affecting the foregoing method of estimating Geological Time are of both signs, and are here enumerated.

Those tending to render the estimate a *minimum* are:—

1. The abstraction of sodium chloride from the ocean by evaporation of sea water in bays or inlets cut off from the sea.
2. The deposition of sodium chloride as a constituent of submarine sediments and deposits.
3. Diminished meteorological activity in the past arising from diminished solar heat, very different distribution of land and water, glacial periods, or other causes.
4. Under-estimate of the supply of sodium chloride to the rivers by rainfall.
5. Diminished river supply of sodium in the past due to lithological differences in rocks and soils exposed to denudation or diminished amounts of organic acids, &c.
6. Under-estimate of the mass of sodium now in the ocean or over-estimate of that delivered in the river-supply to the ocean.
7. Over-estimate of sodium supplied to the ocean by a probable primeval accelerated denudation.

Those tending to render the estimate a *maximum* are:—

1. The supply of sodium to the ocean by direct marine solution of coast materials and sediments.
2. Certain sources of supply of chloride of sodium to the sea otherwise than by normal river supply, as volcanic emissions; denudation of inland Rock Salt deposits into the ocean by brine springs, &c.
3. Increased meteorological activity in the past arising from very different distribution of land and water, glacial periods or other causes.
4. Over-estimate of the supply of chloride of sodium to the rivers by rainfall.
5. Increased river supply of sodium in the past, due to lithological differences in the rocks and soils exposed to denudation or to chemical effects of carbonic acid in rain and river water, &c.
6. Under-estimate of the mass of sodium now in the ocean or under-estimate of that delivered in the river-supply to the ocean.
7. Under-estimate of sodium supplied to the ocean by a probable primeval accelerated denudation.

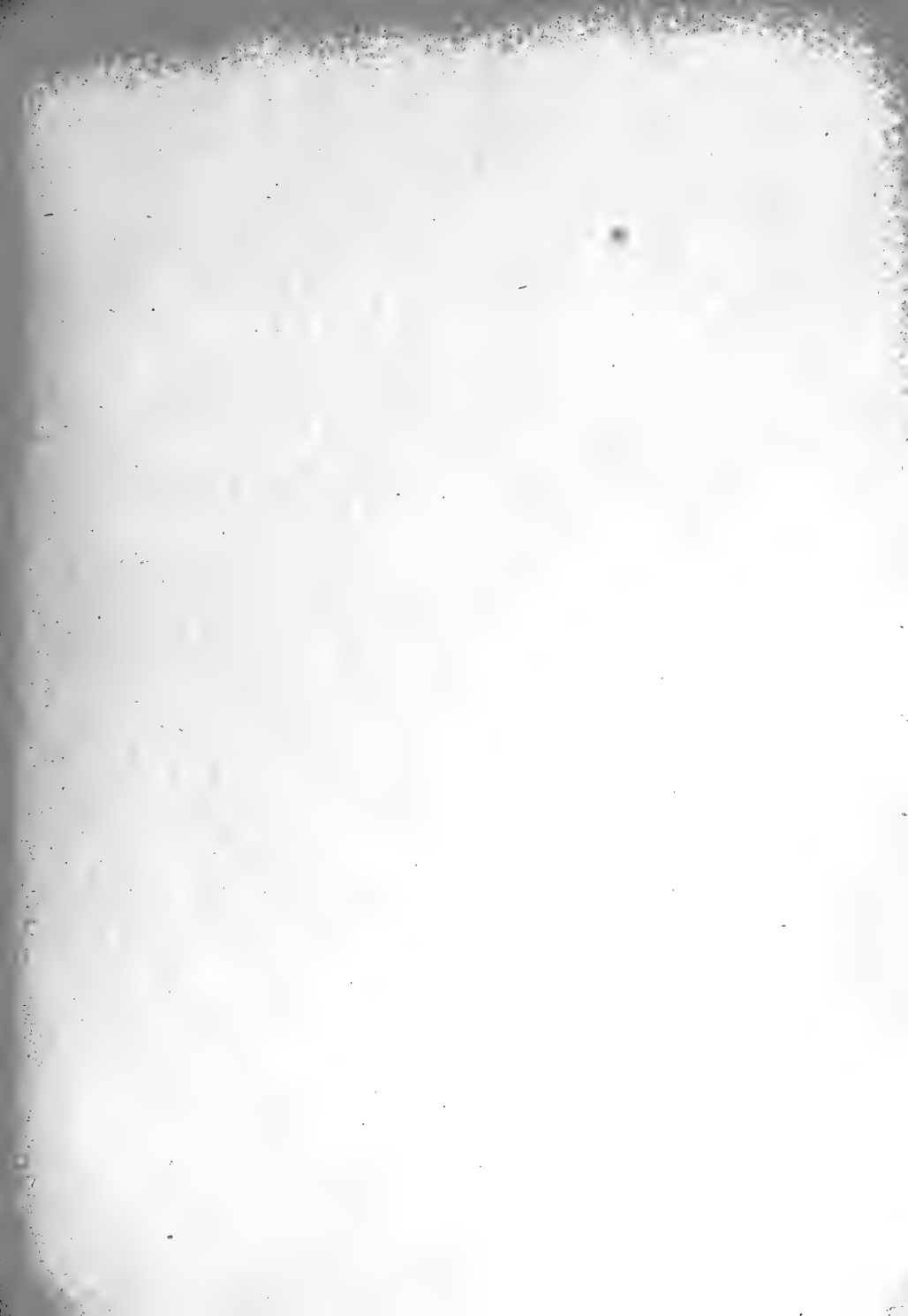

## TRANSACTIONS (SERIES II.).

---

VOL. I.—Parts 1-25.—November, 1877, to September, 1883.

VOL. II.—Parts 1-2.—August, 1879, to April, 1882.

VOL. III.—Parts 1-14.—September, 1883, to November, 1887.

VOL. IV.—Parts 1-14.—April, 1888, to November, 1892.

VOL. V.—Parts 1-13.—May, 1893, to July, 1896.

VOL. VI.—Parts 1-16.—February, 1896, to August, 1898.

---

### VOLUME VII.

PART

1. A Determination of the Wave-lengths of the Principal Lines in the Spectrum of Gallium, showing their Identity with Two Lines in the Solar Spectrum. By W. N. HARTLEY, F.R.S., and HUGH RAMAGE, A.R.C.S.C.I. Plate I. (August, 1898.) 1s.
2. Radiating Phenomena in a Strong Magnetic Field. Part II.—Magnetic Perturbations of the Spectral Lines. By THOMAS PRESTON, M.A., D.SC., F.R.S. (June, 1899.) 1s.
3. An Estimate of the Geological Age of the Earth. By J. JOLY, M.A., B.A.I., D.SC., F.R.S., F.G.S., M.R.I.A., Honorary Secretary of the Royal Dublin Society; Professor of Geology and Mineralogy in the University of Dublin. (November, 1899.) 1s. 6d.

[JANUARY, 1900.]

THE  
SCIENTIFIC TRANSACTIONS

OF THE

ROYAL DUBLIN SOCIETY.

VOLUME VII.—(SERIES II.)

---

IV.

ON THE ELECTRICAL CONDUCTIVITY AND MAGNETIC PERMEABILITY  
OF VARIOUS ALLOYS OF IRON.

By W. F. BARRETT, F.R.S.; W. BROWN, B.Sc.; R. A. HADFIELD, M.Inst.C.E.

(PLATES II. TO IX.)

DUBLIN:  
PUBLISHED BY THE ROYAL DUBLIN SOCIETY.  
WILLIAMS AND NORGATE,  
14, HENRIETTA STREET, COVENT GARDEN, LONDON;  
20, SOUTH FREDERICK STREET, EDINBURGH; AND 7, BROAD STREET, OXFORD.  
PRINTED AT THE UNIVERSITY PRESS, BY PONSONBY AND WELDRICK.

1900.

---

*Price Four Shillings.*





BARRETT, W. F., BROWN, W., and HADFIELD, R. A.—On the Electrical Conductivity and Magnetic Permeability of various Alloys of Iron.  
Roy. Dublin Soc. Trans., s. 2, vol. 7, 1900, pp. 67-126.

Iron, Electrical Conductivity and Magnetic Permeability of various Alloys of.  
Barrett, W. F., Brown, W., and Hadfield, R. A.  
Roy. Dublin Soc. Trans., s. 2, vol. 7, 1900, pp. 67-126.



[JANUARY, 1900.]

THE

SCIENTIFIC TRANSACTIONS

OF THE

ROYAL DUBLIN SOCIETY.

VOLUME VII.—(SERIES II.)

---

IV.

ON THE ELECTRICAL CONDUCTIVITY AND MAGNETIC PERMEABILITY  
OF VARIOUS ALLOYS OF IRON.

By W. F. BARRETT, F.R.S.; W. BROWN, B.Sc.; R. A. HADFIELD, M. Inst. C.E.

(PLATES II. TO IX.)

---

DUBLIN:

PUBLISHED BY THE ROYAL DUBLIN SOCIETY.

WILLIAMS AND NORGATE,

14, HENRIETTA STREET, COVENT GARDEN, LONDON,

20, SOUTH FREDERICK STREET, EDINBURGH; AND 7, BROAD STREET, OXFORD.

PRINTED AT THE UNIVERSITY PRESS, BY PONSONBY AND WELDRICK.

1900.



## IV.

ON THE ELECTRICAL CONDUCTIVITY AND MAGNETIC PERMEABILITY  
OF VARIOUS ALLOYS OF IRON.\*

By W. F. BARRETT, F.R.S.; W. BROWN, B.Sc.; R. A. HADFIELD, M. Inst. C.E.

(PLATES II.-IX.)

[Read FEBRUARY 22 (Part I.); MAY 17 (Part II.), 1899.]

## INTRODUCTORY.

THE first part of the present paper contains the results of an examination of the electrical conductivity of upwards of one hundred alloys of iron, very many of these alloys being entirely new metallurgical products: the second part contains an examination of the magnetic properties of typical specimens of these alloys, complete **B** and **H** curves being made in each case.

In addition to the iron alloys described in the first part, many others were made, but rejected, either owing to the difficulty of getting good castings or the impossibility of forging or rolling the specimens.

*Process of Manufacture.*

For the purpose of the present research, there remained upwards of one hundred different alloys of iron or "steels," which appeared to be fairly homogeneous, and could be forged and rolled. These specimens were rolled into rods of a uniform thickness, and of as small a diameter as could conveniently be obtained. In general the process of manufacture was as follows:—

Ingots,  $2\frac{1}{2}$  inches square, were cast of each alloy; these ingots were then forged and rolled at a bright red heat (about  $900^{\circ}\text{C}$ .) into bars  $1\frac{1}{4}$  inch diameter. These bars were again heated to  $900^{\circ}\text{C}$ . and rolled into the experimental rods, which were of nearly circular cross-section and approximately 0.2 inch in

\* A joint authorship is given to this paper, as the preparation of the various alloys, and the determination of their chemical composition and mechanical properties were undertaken by Mr. Hadfield at the Hecla Steel Works, Sheffield, whilst the investigation of the physical properties of these alloys, described in the present paper, was made by myself, and Mr. Brown, at the Royal College of Science for Ireland.—W. F. B.

diameter (No. 5 B. W. G.). They were then cut into uniform lengths of about 42 inches (106 cms.) long, and once more heated to 700° C. in order to be straightened.

In the first instance the rods were all tested for electric conductivity in the state in which they were received, that is "as rolled" or unannealed, as this is the usual condition under which rods or wires are supplied in commerce. But the effect of rolling in many cases left the rods in a more or less hardened or strained condition, which, as anticipated, was found to affect the electric conductivity to some extent, and still more the magnetic permeability. Hence, in order to reduce them all to precisely the same physical state, they were sent back to Sheffield to be annealed, and on their return were all re-tested.

The annealing was conducted as follows:—The rods were heated in an annealing furnace to a temperature of a white heat (about 1000° C.), and allowed to cool down slowly in an east and west position for a period of nearly 100 hours, so that the cooling occupied upwards of four days and four nights.

In order to compare the electric and magnetic properties of the same alloy, after different thermal treatment, a duplicate set of some of the specimens, especially the "nickel steels," were prepared both in the annealed and unannealed states, the latter meaning "as rolled" without further treatment; a third sample of a few specimens were also prepared which were "water-quenched," *i.e.* the rods were heated to about 1000° C., and plunged into cold water at this white heat.

#### *Composition of the Specimens.*

A chemical analysis of all the specimens was made in the chemical laboratory attached to the Hecla Steel Works. In some cases an ultimate analysis was undertaken; this would have been desirable in every case, but the labour and time involved in an exhaustive analysis of such an extensive series was impracticable in the first instance. Except, therefore, where specially mentioned and the details given, the analysis must be taken to indicate the main constituents of the specimens.

The various alloys of iron, for brevity, though in many cases incorrectly, called "steels," which we have tested, may be divided into three classes:—

- I. Those consisting of one element added to the iron.
- II. Those consisting of two added elements.
- III. Those consisting of three or more elements added to the iron.

Each of these classes consisted of numerous groups, and each group contained from one to a dozen specimens, having different percentages of the added element or elements. After their manufacture a distinctive mark or number was

stamped on each specimen so as to avoid mistakes and facilitate reference. These marks also give some indication of the history of the specimens: thus a series of similar numbers but with different letters attached, e.g. 1167 D, 1167 H, 1167 I, tell us that it is the same batch of "steels," with different proportions of the added element or elements:—

CLASS I.

Group.	Description.	No. of Specimens.	Group.	Description.	No. of Specimens.
1.	Carbon steels, . . . . .	13	5.	Aluminium steels, . . . . .	3
2.	Manganese steels, . . . . .	18	6.	Silicon ,, . . . . .	2
3.	Nickel ,, . . . . .	12	7.	Chromium ,, . . . . .	3
4.	Tungsten ,, . . . . .	4	8.	Copper ,, . . . . .	4

CLASS II.

Group.	Description.	No. of Specimens.	Group.	Description.	No. of Specimens.
9.	Nickel—Copper steel, . . . . .	1	16.	Manganese—Copper steels, . . . . .	2
10.	,, Chromium steels, . . . . .	6	17.	Chromium—Aluminium steels, . . . . .	4
11.	,, Silicon ,, . . . . .	5	18.	,, Silicon ,, . . . . .	3
12.	,, Manganese ,, . . . . .	9	19.	,, Copper steel, . . . . .	1
13.	Manganese—Chromium steels, . . . . .	4	20.	,, Tungsten ,, . . . . .	1
14.	,, Tungsten ,, . . . . .	4	21.	Aluminium—Copper ,, . . . . .	1
15.	,, Silicon ,, . . . . .	2	22.	,, Silicon ,, . . . . .	1

CLASS III.

Group.	Description.	No. of Specimens.	Group.	Description.	No. of Specimens.
23.	Cobalt—Manganese—Silicon steels, . . . . .	2	27.	Nickel—Manganese—Aluminium—Silicon steel, . . . . .	1
24.	Nickel—Manganese—Copper steel, . . . . .	1	28.	Copper—Manganese—Chromium steel, . . . . .	1
25.	Chromium—Tungsten—Copper ,, . . . . .	1			
26.	Chromium—Manganese—Silicon ,, . . . . .	1			

PART I.

ELECTRICAL CONDUCTIVITY.

*Method of Measurement.*

As the rods were about half a centimetre diameter and a little over a metre long, the ordinary method of determining the resistance was unsuitable; accordingly the potential method of measuring conductivity was employed. Each specimen was compared with a standard of pure copper, of high and known conductivity, and also subsequently with a standard iron rod, of the purest commercial iron obtainable. A complete analysis of this standard iron (an excellent

specimen of Swedish charcoal iron, marked S.C.I.) was made with the following result:—

Carbon, . . . . .	0·028 per cent.
Silicon, . . . . .	0·070 „
Sulphur, . . . . .	0·005 „
Phosphorus, . . . . .	0·044 „
Manganese, . . . . .	(a trace) „
Iron, . . . . .	99·85 (by difference).

This standard iron rod was accurately turned to a uniform diameter throughout. Its dimensions were 104 cms. long, and 0·4889 cm. diameter, and it contained, as seen above, less than 0·03 per cent. of carbon. The electrical arrangements, shown diagrammatically in fig. 1, were as follows:—

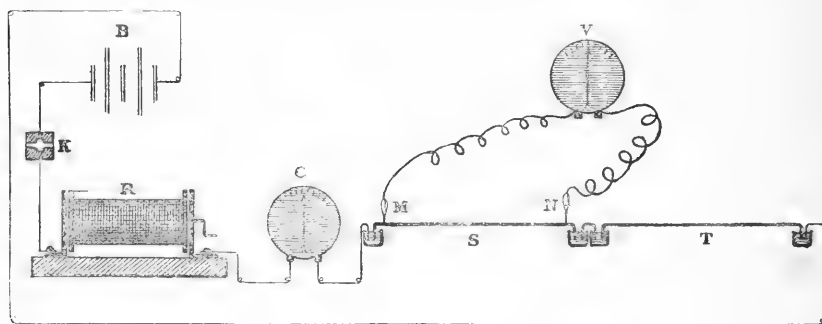

FIG. 1.

The standard rod *S*, and the rod to be tested, *T*, were put in series with a battery *B*, a variable resistance *R*, and a Weston ampère-meter *G* reading to one-hundredths of an ampère; when the plug key, *K*, was inserted, a constant current could be maintained through *S* and *T* by altering *R*. Flexible leads were taken from a sensitive high resistance dead-beat reflecting galvanometer *V*, to two copper knife-edges *M* and *N*, which acted as contact-pieces to the rods. The fall of potential over a definite known length of each rod was thus obtained on reading the deflection given by the potential galvanometer *V*. Contacts were first made with the standard *S*, then with the test *T*, and again with the standard (as a check on the constancy of the current), and the deflection in each case noted. The fall of potential over one-half and over one-quarter of the rod under test was also taken and compared with the standard; by this means the homogeneity and uniformity of sectional area in the rods were tested, as the deflections in these cases should be one-half and one quarter of that given by the whole rod. The diameter of each of the rods under examination was taken in six



different places by means of a micrometer-screw reading to one 0·01 millim., and the mean of the readings was taken as the true diameter: the diameters of the standards were similarly determined once for all.\* The conductivity of the test rod was calculated in terms of pure copper, Matthiessen's standard of pure copper being taken as 100; our own specimen was 1·01 per cent. higher conductivity than Matthiessen's†; allowance for this was made in the following calculation for the conductivity of the rods under test:—

$l$  = length of standard.

$l'$  = length of rod under test.

$d$  = deflection due to fall of potential in standard.

$d'$  = deflection due to fall of potential in test rod.

$a$  = cross-sectional area of standard.

$a'$  = cross-sectional area of test rod.

$c$  = conductivity of standard.

$c'$  = conductivity of test rod.

$$c' = \frac{d l' a}{d' l a'} c.$$

The following comparison of the iron standard with the copper standard will serve as an example of the series of readings taken with all the rods:—

STANDARD IRON (Temperature 15° C.).

MARK.	$d$	$d'$	$a$	$a'$	$l$	$l'$	$c$ .
S.C.I.	140·5	54·8	0·0121	0·1874	100	98	101·01

from which the conductivity  $c'$  was deduced thus:—

$$c' = \frac{140\cdot5 \times 98 \times 0\cdot0121}{54\cdot8 \times 100 \times 0\cdot1874} 101\cdot01$$

or conductivity of standard iron = 16·35, pure copper being taken as 100.

\* The cross-section of the rods was slightly elliptical, and, moreover, not quite uniform throughout their length; later on in the investigation, the mean cross-sectional area of each rod was more accurately and expeditiously determined by measuring the length of the rod carefully, and then obtaining its volume by displacement of water in a long glass tube, 1 cm. diameter, graduated to tenths of a c.c. This method of measurement gave such excellent results that the conductivities of the whole of the *annealed* rods were re-determined after this paper had been printed, and the corrected results were inserted in the proof, wherever any sensible difference was found. Hence the unannealed results are less reliable.

† The standard copper was supplied by Messrs. White & Co., of Glasgow, and the conductivity of the sample determined in Lord Kelvin's Laboratory at the University of Glasgow.

The copper standard was in the form of wire (0.124 cm. diameter), whilst the iron standard and the alloys to be tested were in the form of rods (0.55 cm. diameter). In order to compare the copper and iron standards in the same physical condition, and also to check the comparison of their conductivity just given, a careful comparison was made of the *specific resistance* of the copper and of that of the iron. For this purpose a sample of the standard iron was drawn into wire of about the same diameter as the standard copper: a determination of its specific resistance gave 10.47 microhms per c.c. at 18° C. The specific resistance of the copper was found to be 1.721 microhms per c.c. at 18° C.\* The ratio of the reciprocals of these two numbers give the conductivity of iron as 16.36, copper being taken as 100.

The standard iron *wire* was now compared directly with the standard copper wire by the potential method, and the result gave a conductivity of 16.37 for iron, copper being 100; practically the same result as when the standard iron *rod* was compared with the standard copper *wire*. The mean of these three results gives a value of

$$16.36$$

for the conductivity of our standard iron, Matthiessen's copper being taken as 100 and at the same temperature.

The foregoing experiments also enable us (1) to obtain a factor for the conversion of the conductivities of the various alloys given in the tables below into specific resistances in microhms per c.c.; and (2) to give the conductivities of the alloys in terms of the standard *iron*, taken as 100. In the former case all that is necessary is to divide 172.1 by the conductivity of the specimen as compared with copper, and the result is the specific resistance  $\sigma'$  of the alloy in microhms per c.c.† In the latter case it is only necessary to multiply the conductivity of the specimen in terms of copper by 100, and divide by 16.36, or, in the case of the *annealed* specimens, divide by 16.8. Taking, for example, the last specimen named in the table on the opposite page, 1392 G, which in the annealed state has a conductivity of 9.8, copper being 100, we get

$$\frac{9.8 \times 100}{16.8} = 58.33,$$

which gives its conductivity, taking the standard iron as 100.

\* The resistance of both the iron and the copper here given is somewhat higher than usually stated in the table of physical constants, even at 18° C.; this is due to the fact that both the copper and iron in the above test were unannealed. The resistance of the copper was determined in Lord Kelvin's laboratory as well as by ourselves.

† The reason for this is that the specific resistance  $\sigma$  of the standard copper is 1.721 microhms at the temperature at which the experiments were made, and as  $\frac{\sigma}{\sigma'} = \frac{c'}{c}$   $\sigma' = \frac{1.721 \times 100}{c'}$ .

## CLASS I.

## Carbon Steels.

Beginning with the *Carbon steels*, it is necessary to subdivide the specimens into two series, one of which (A) is freer from other elements, such as manganese and silicon, than the other series (B): as might be expected, the former has a higher conductivity than the latter. The chemical analysis in percentages for each specimen is given in the tables following, *iron being understood in all cases to make up the total to 100*. The last column gives the calculated specific resistance in microhms per c.c. at about 17°C. The letters *Unann.* and *Ann.* signify the conductivity in the unannealed and the annealed conditions respectively.

## Group 1.—CARBON STEELS (Series A).

Marks.	Percentage Composition.			Conductivity Copper = 100.		Specific resistance in microhms (calculated).	
	C	Si	Mn	Unann.	Ann.	Unann.	Ann.
*S.C.I.	0.028	0.07	Trace.	16.4	16.8	10.5	10.2
*B.	0.03	0.14	0.036	15.5	15.7	11.1	10.9
*L.S.S.	0.05	0.02	0.18	14.9	15.2	11.5	11.3
1166 A.	0.14	0.08	—	12.8	13.2	13.4	13.0
1392 H.	0.78	0.10	0.10	10.7	11.8	16.1	14.6
1392 I.	0.83	0.06	0.25	10.3	11.3	16.7	15.2
1392 B.	0.84	0.20	0.18	10.0	10.7	17.2	16.1
1392 A.	0.85	0.17	0.32	9.6	10.5	17.9	16.4
1392 L.	1.09	0.17	0.32	9.8	10.6	17.6	16.2
1392 G.	1.23	0.12	0.14	9.0	9.8	19.1	17.6

It will be seen that the conductivity decreases as the percentage of carbon increases, at first very rapidly, so that the conductivity of chemically pure iron would certainly be higher than the specimen S.C.I. The resistance of the specimen L.S.S. is a little greater than B., owing to the presence of a larger

\* A complete analysis of the first three specimens was made as follows :—

Mark.	C	Si	S	P	Mn	Fe
S.C.I.	0.028	0.07	0.005	0.004	Trace.	99.85
B.	0.030	0.14	0.016	0.065	0.036	99.71
L.S.S.	0.050	0.02	0.011	0.013	0.180	99.72

manganese impurity.\* The specimens 1392 I, B and A, are almost alike in the percentage of carbon they contain, the difference in conductivity being due to the differences in the quantity of silicon and manganese present. It will be noticed that annealing in all cases increases the conductivity. The next series (B) are less pure carbon steels, and have a lower order of conductivity.

#### CARBON STEELS (Series B).

Marks.	Percentage Composition.			Conductivity Copper = 100.		Specific resistance (calculated).	
	C	Si	Mn	Unann.	Ann.	Unann.	Ann.
611	0.58	0.49	0.58	7.5	8.0	23.1	21.5
613	1.00	„	„	6.8	7.7	25.2	22.3
614	1.25	0.46	0.62	6.5	7.3	26.6	23.6

The result of analysis shows that manganese, and, as a rule, silicon, are present in not inconsiderable quantities in these specimens, so that they may be regarded as low manganese steels.

The foregoing results are plotted in the accompanying curves, fig. 2, where percentages of carbon are taken as abscissæ, and conductivity as ordinates.† The departures from the smooth curve which is drawn are not very great, and would doubtless disappear if the specimens were of uniform purity, with the exception of the added carbon. In fact an approximate estimate of the quantity of carbon in any specimen of carbon steel might be quickly obtained by a determination of the electric conductivity of the particular sample, *provided* the other constituents, especially the silicon and manganese, were practically uniform throughout the specimens. On the other hand, from the electrical conductivity of samples of steel, in which the percentage of carbon only is known, we can infer the purity or otherwise of the samples, and can arrange them into series of high or low-class steels. As a matter of fact this was done in the above specimens, when only the amount of carbon present was known; and the division into series A and B was fully justified when we received the full analysis.

It will be interesting to compare the increase of resistance for each *one* per cent. of the added element in these and the other steels in Class I. In every case the comparison will be made of the specimens in the *annealed* state.

The *first* four specimens in Series A show that an increased resistance of

\* The conductivity of 1392 L is a little higher than its composition would indicate. There is probably a slight error here in the chemical analysis of this alloy.

† A slight correction needs to be made in the lower part of series A curve, which should be a little lower than shown, as by mistake this part of the curve was plotted from some annealed specimens, the rest of the curves, both in series A and B, being taken from the unannealed rods.

2.8 microhms per c.c. is produced by a rise in the carbon from 0.028 to 0.14 per cent.; this would indicate an increase of 2.5 microhms in the specific resistance for every *tenth per cent.* of carbon added in these low carbon steels. The last six

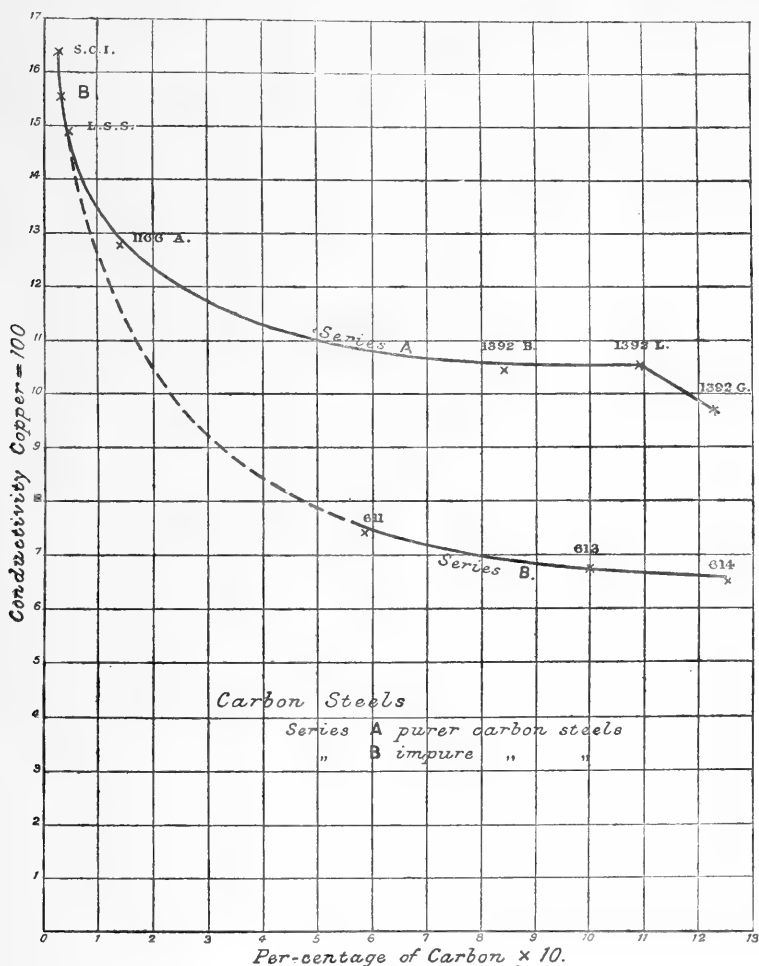

FIG. 2.

specimens in Series A show that an increased resistance of 3.0 microhms is produced by a rise in the carbon from 0.78 to 1.23 per cent.; this gives an increase in the specific resistance of 0.66 microhms for every *tenth per cent.* of carbon

added, or 6.6 microhms for 1 per cent. of carbon. The rate of increase of resistance for a given increment of carbon being some four times greater in the former case than in the latter. This rapid fall of conductivity for the first small additions of carbon is seen in fig. 2 and Plate II.

#### Alloys of Iron and Manganese.

We will next take the alloys of *Iron* and *Manganese*, of which an extensive series was made for this investigation. This series may also be subdivided into two groups, Series A and B, the latter containing higher carbon.

#### Group 2.—ALLOYS OF IRON AND MANGANESE (Series A).

Marks.	Percentage Composition.		Conductivity Copper = 100.		Specific resistance in microhms (calculated).	
	Mn	C	Unann.	Ann.	Unann.	Ann.
48	0.50	0.20	11.4	11.90	14.96	14.46
4147	1.00	0.24	6.9	7.30	24.94	23.57
53	2.25	0.41	5.4	5.90	31.86	29.18
1379 B*	3.50	0.08	5.5	5.80	31.29	29.67
39	4.00	0.36	5.1	6.00	33.74	28.69
34	4.75	0.36	4.5	5.86	38.23	29.38
32	5.15	0.32	3.7	4.60	46.50	37.41
1323 C	5.40	0.15	3.7	5.10	46.51	33.74
1338 B/2	13.00	0.26	2.7	2.80	63.70	61.50
1379 D/2	15.20	0.15	2.56	2.65	67.00	64.94

#### ALLOYS OF IRON AND MANGANESE (Series B).

Marks.	Percentage Composition.		Conductivity Copper = 100.	Specific resistance in microhms (calculated).
	Mn	C	Annealed.	Annealed.
1420 A	1.00	0.75	6.4	26.88
1381	3.81	0.78	3.9	44.12
945 A	7.00	1.20	3.1	58.74
1379 D†	10.10	0.16	2.7	63.72
1310 B	11.50	1.66	2.8	61.50
1010	13.00	1.23	2.7	63.60
30	15.25	1.50	2.6	66.18
598	18.50	1.54	2.5	69.0

\* 1379 B also contains 0.13 per cent. of silicon.

† 1379 D also contains 0.63 per cent. of silicon.

These results are plotted in the accompanying curves, fig. 3. The specimens marked respectively 1379 B and 1323 C, owing to their low carbon, have a higher order of conductivity than their true place in the series, and the former causes the peculiar hump in the curve of Series A.\* When the percentage of manganese in the alloy is high (say over 7 per cent.) the resistance is so great that the presence of  $\frac{1}{2}$  or even 1 per cent. more carbon makes little difference in the conductivity; hence the last two specimens in Series A are plotted in the Series B curve.

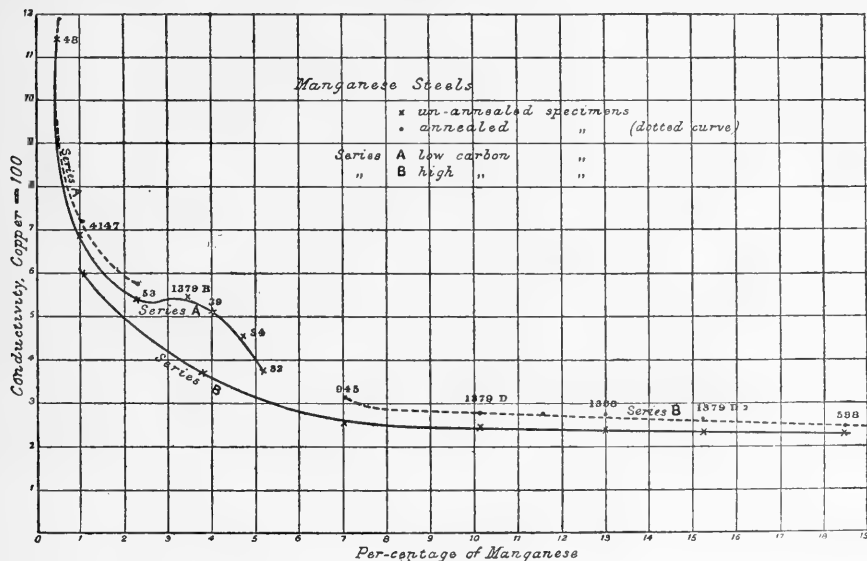

FIG. 3.

As in the case of the carbon steels it will be noticed how very rapidly the conductivity falls for the first small additions of manganese, whereas after 7 per cent. further additions appear to have comparatively little effect on the conductivity. The first two specimens in Series A show that an increase in the percentage of manganese from  $\frac{1}{2}$  to 1 per cent. causes an increase of sp. resistance at the rate of 1.82 microhms for every *one-tenth* per cent. of

\*The curves were engraved in all cases from the earlier determinations of the conductivity. The values shown in the tables for the conductivities of the annealed rods are more correct, the difference being due to the more exact method of finding the sectional area by means of displacement, as already explained in the footnote to p. 71. The specimens marked 39 and 34 have an anomalous conductivity in the annealed state; this result may be due to some change produced by the annealing process. The effect of heat treatment on the physical properties of manganese and nickel steels needs further investigation.

added manganese. The next six specimens in the same series show that an increase of from 1 to 5·4 per cent. in the manganese causes the sp. resistance to rise at the rate of say a quarter of a microhm for every tenth per cent., or 2·3 microhms for each 1 per cent. of added manganese.\*

#### Alloys of Iron and Nickel.

The next group is an extensive and extremely interesting series of alloys of *Iron* and *Nickel*: a large set of these alloys was prepared, ranging from one-quarter per cent. to fifty per cent. of nickel. About one-half of the whole series of specimens were tested for conductivity, these having been rolled into test-rods 106 cms. long, and about half a centimetre in diameter; some specimens were also drawn in the form of wire. The conductivity of the test-rods measured was as follows:—

Group 3.—ALLOYS OF IRON AND NICKEL (Series A).

Marks.	Percentage Composition.				Conductivity Copper=100.		Specific resistance in microhms (calculated).	
	Ni	Mn	Si	C	Unann.	Ann.	Unann.	Ann.
1397 B	0·58	0·18	0·33	0·26	9·0	9·4	19·12	18·31
1287 D	1·92	0·72	0·21	0·14	8·0	8·4	21·51	20·44
„ E	3·82	0·65	0·20	0·19	6·9	7·2	24·94	24·57
„ I	11·39	0·93	0·22	0·18	4·5	4·8	38·23	35·82
„ K	19·64	0·93	0·27	0·19	4·0	4·4	43·01	39·01
„ L	24·51	1·00	0·30	0·16	3·1	3·8	55·50	45·12
1449 A	31·40	0·82	—	0·70	—	2·0	—	86·04

\*The remarkable physical properties possessed by steel containing from 10 to 13 per cent. of manganese were discovered by one of us upwards of twelve years ago. The electric resistance of a wire, containing some 13 per cent. of manganese, was found to be 70 microhms per c.c. at 15° C.

A complete analysis of this alloy showed its composition to be:—

Manganese,	. . . . .	13·75
Carbon,	. . . . .	0·85
Silicon,	. . . . .	0·25
Phosphorus,	. . . . .	0·10
Sulphur,	. . . . .	0·09
Iron,	. . . . .	84·96

100·00

This alloy was non-magnetic; its density was 7·81. The modulus of elasticity (Young's modulus) of the wire in the hard state was found to be  $1680 \times 10^6$  grammes per sq. cm., and in the soft (or suddenly cooled) state  $1500 \times 10^6$  grammes per sq. cm. Unlike carbon steels, the high manganese steels are rendered softer by suddenly cooling. The tenacity of this wire (No. 19 B.W.G., or 0·98 millimetre diameter) was very great; in the hard state the breaking stress of some specimens ranges from 107 to 110 tons per sq. inch, with a scarcely perceptible elongation (about 1 per cent.); in the soft state the tenacity was about half the foregoing.—*Proc. Royal Dublin Society*, 1886 and 1889. W. F. B.



The above results are plotted in the curves shown in fig. 4. The last specimen contains high carbon, and hence its conductivity is of a lower order than it would otherwise be. One other specimen of nickel steel containing high carbon is not included in the foregoing table, as it belongs to a different batch. It is marked 1267 B, and contains 4.75 per cent. of nickel, and 0.8 per cent. of carbon. Its conductivity in the unannealed state was 3.8, and in the annealed state 5.1, copper being taken as 100.

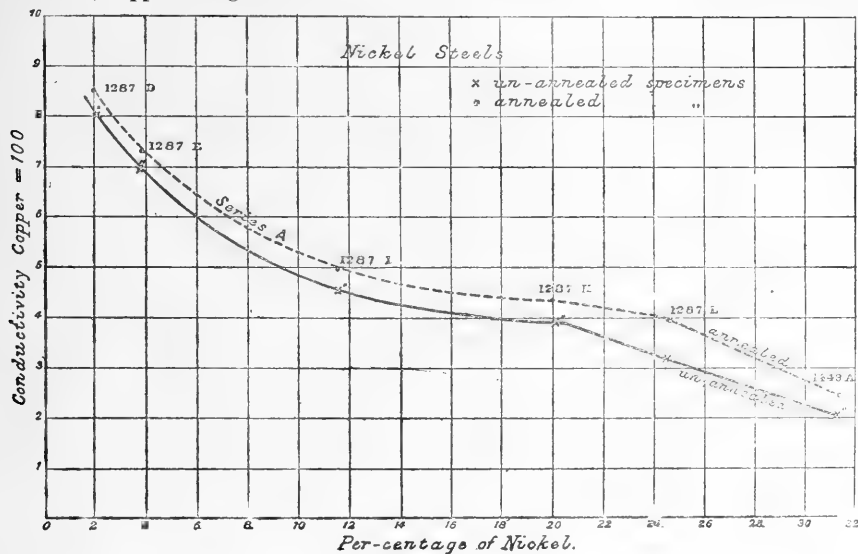

FIG. 4.

It will be noticed annealing has a marked effect in increasing the conductivity of those steels: in fact the particular thermal treatment that certain alloys of nickel steel are submitted to after manufacture is of considerable importance in modifying their physical properties. This will be strikingly seen when the magnetic permeability of these specimens is given. Three specimens of 1287 K and three of 1287 L (19.64 and 24.5% nickel) were made, one being unannealed or left as rolled; the next annealed by slow cooling for 100 hours in the annealing oven; and the third, heated to whiteness, and then suddenly quenched in water. The electric conductivity of each was determined, the water-quenched specimens in each case were found to have a conductivity midway between the rolled and annealed specimens given above in Group 3.\*

\*The specimens 1287 K and L remained bright, with but slight oxidation, in an atmosphere which had oxidised most of the other alloys, and some of them very considerably.

The addition of nickel does not appear to have so great an effect in lowering the electric conductivity of iron as is produced by many other elements. This will be seen from an inspection of the curves in fig. 4 and Plate II., which show that the fall of conductivity by the addition of small percentages of nickel is not so rapid as is the case with carbon, manganese, &c. From 0·58 to 11·39 per cent. of added nickel, the increase of sp. resistance is fairly uniform, being at the rate of 1·6 microhms for each 1 per cent. of nickel added to the iron, a rate that only slightly diminishes even in the alloys containing up to 24 per cent. of nickel. When, however, carbon, silicon, or manganese are also present, even in comparatively small quantities, a considerable reduction of conductivity occurs. Hence the conductivity of the specimens given in Group 3 would, especially in the low percentages of nickel, have been of a higher order had the specimens been able to be manufactured without the admixture of the foreign bodies named. (See also p. 91.)

The following experiments show that the addition of a small quantity of nickel does not have much effect on the conductivity of a *poor* steel. Two specimens, 1420 A and B, were made as nearly alike as possible, except that B had 1 per cent. of nickel added to it. In comparing the conductivity of the two specimens, that which contained the nickel was found to be almost as good a conductor as the specimen 1420 A, which had no nickel; the latter, however, had slightly higher carbon. Much the same result was given by two other specimens, 1397 A and B, one of which, A, contained about half a per-cent. of nickel, and the other had no nickel. Again, in two specimens, 1447 A and B, one with 12·7 and the other with 12·1 per cent. of nickel, the former was found a slightly better conductor than the latter, which had, it is true, a somewhat higher percentage of silicon and carbon.

#### NICKEL STEELS (Series B).

Marks.	Percentage Composition.				Conductivity Copper = 100.		Specific resistance in microhms (calculated).	
	Ni	Mn	Si	C	Unann.	Ann.	Unann.	Ann.
1420 A	—	1·00	—	0·75	5·7	6·4	30·2	26·9
„ B	1·00	1·00	—	0·50	5·6	6·1	30·7	28·0
1397 A	—	0·18	0·44	0·22	9·4	10·1	18·3	17·0
„ B	0·58	0·18	0·33	0·26	9·1	9·6	18·9	17·9
1447 A	12·70	0·61	0·39	0·81	3·7	3·9	46·5	44·1
„ B	12·10	0·61	0·56	0·98	3·6	3·8	47·7	45·3
1449 E	30·00	1·50	—	0·60	—	1·95	—	88·2

It will be noticed that the conductivity of 1447 B in the unannealed state is much lower than 1287 I in Series A, though both have nearly the same percentage of nickel. This is doubtless owing to the high carbon in the former specimen. So also the last specimen of Series A, 1449 A, with 31·4 per cent. of nickel (which might have been included in Series B), doubtless owes its remarkably low conductivity, in part, to the 0·7 per cent. of carbon which is added to the nickel. It may be that a carbide of nickel is formed in these cases, which, diffused throughout the steel, would produce a very high electric resistance. The specimen 1449 E owes its high resistance in part to the presence of manganese; it is really a nickel manganese steel, and as such is given again later in Group 12, p. 89.

The alloy 1449 A was a ductile and beautiful material, and easily drawn into wire. A thin wire of this alloy was, therefore, made and submitted to further examination. Its electric resistance was carefully measured by the usual method, and the specific resistance found to have the large value of 86 microhms per c.c. at 15° C. This corresponds with the estimated specific resistance from the conductivity of a rod of the same material. The temperature coefficient of this remarkable alloy was also determined, and found to be 0·09 per cent. for 1° C.

Enormous as is the resistance of this alloy, it is exceeded by another specimen which has more manganese and less nickel added to the iron; it is, therefore, a cheaper material, and has an equally good temperature coefficient. This specimen, marked 1414 B, contained 25 per cent. of nickel and 5 per cent. of manganese. It is, therefore, a nickel manganese steel, and will be referred to later on with others of the same class in Group 12.

### Tungsten Steels.

We next pass on to the alloys of tungsten and iron.

#### Group 4.—TUNGSTEN STEELS.

Marks.	Percentage Composition.			Conductivity Copper = 100.		Specific resistance in microhms (calculated).	
	Tun	Mn	C	Unann.	Ann.	Unann.	Ann.
1294 F	1·0	0·11	0·16	10·9	11·4	15·8	15·1
1294 H	3·5	0·28	0·28	8·0	9·6	21·5	18·0
1294 I	7·5	0·20	0·38	7·0	8·9	24·6	19·2
1294 L	15·5	0·28	0·76	4·8	6·4	35·7	26·6

The unannealed results are plotted in the next curve; the more rapid fall in the first part of the curve is partly due to the greater purity of the first specimen 1294 F. Annealing, it will be noticed, produces a great increase in the conductivity of the higher tungsten steels. The effect of tungsten on the conductivity of pure iron is less than that of any other added metal which we have so far examined (except in the case of copper, the results of which are indefinite, see p. 85): this will be seen from Plate II. Between  $3\frac{1}{2}$  and  $15\frac{1}{2}$  per cent. of tungsten

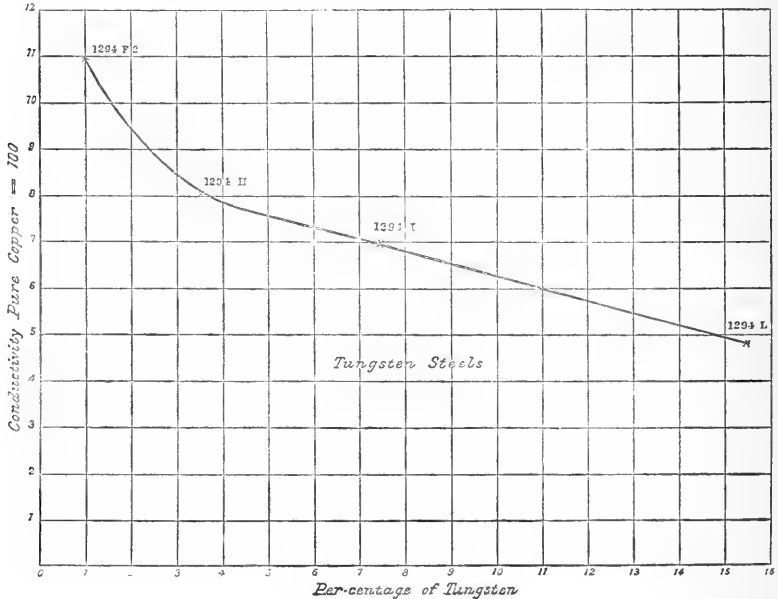

FIG. 5.

in the alloy, the increase of specific resistance is 8.6 microhms, which is equivalent to an increase of 0.72 microhms for every one per cent. of tungsten added to the iron. Comparing 1294 H and I, the increase of specific resistance for one per cent. of added tungsten is only 0.3 microhms, these specimens being more comparable as they contain nearly the same amount of impurities; for lower percentages the rate of increase is higher.

#### Aluminium Steels. Silicon Steels. Chromium Steels.

The next group, alloys of aluminium and iron, are remarkable for their extremely low order of conductivity.

## Group 5.—ALUMINIUM STEELS.

Marks.	Percentage Composition.			Conductivity Copper = 100.		Specific resistance (calculated).	
	Al	C	Si	Unann.	Ann.	Unann.	Ann.
1167 D	0.75	0.17	0.10	6.9	7.8	24.8	22.0
1167 H	2.25	0.24	0.18	3.7	4.4	46.3	39.0
1167 I	5.50	0.22	0.20	2.2	2.5	78.1	70.0

It will be seen, upon referring to Plate II., that the curve is a very smooth one: the samples being fairly uniform in their composition, except as regards the percentage of aluminium. The curve shows us that the reduction of conductivity by adding comparatively small percentages of aluminium to iron is most startling, being greater than that of any other metal so far examined. Between 0.75 and 5.5 per cent. of added aluminium, the specific resistance increases 48.0 microhms, equivalent to an increase of 10.1 microhms for every 1 per cent. of aluminium added to the iron; between 2.25 and 5.5 per cent. of aluminium, nearly the same increase occurs, viz. 9.5 microhms. (See also p. 94.)

The alloy No. 1167 I with  $5\frac{1}{2}$  per cent. of aluminium was soft and ductile: a sample was rolled into strip, and drawn into wire No. 20 B.W.G., and the specific resistance and temperature coefficient of both carefully determined. The mean specific resistance of the annealed wire was found to be 74.69 microhms per c.c. at 15° C.; the resistance of the strip was slightly lower. The specific resistance of the annealed *rod* of the same alloy, calculated from the conductivity given in Group 5, was somewhat lower. The percentage variation of resistance for increase of temperature was found to be 0.063 per 1° C. between 0° and 150° C. This is remarkably good, being exactly ten times less than iron, and nearly as low as German silver, which has a temperature coefficient of 0.044. As the resistance of this aluminium steel is three and a half times greater than German silver, it promises to be a valuable and cheap alloy for use in resistance coils, though we cannot yet speak of its behaviour after repeated heating and cooling.

We now come to the alloys of silicon and iron:—

## Group 6.—SILICON STEELS.

Marks.	Percentage Composition.		Conductivity Copper = 100.		Specific resistance (calculated).	
	Si	C	Unann.	Ann.	Unann.	Ann.
898 E	2.5	0.20	3.65	4.09	47.1	42.1
„ H	5.5	0.26	2.50	2.64	68.8	65.2

Silicon, like carbon and aluminium, has a powerful effect in reducing the conductivity of iron. The composition of the two specimens above-named is fairly uniform, except for the added silicon. Between  $2\frac{1}{2}$  to  $5\frac{1}{2}$  per cent. of silicon, an increase of 7·7 microhms is produced in the electric resistance of the alloy for every 1 per cent. of added silicon; between 0 and  $2\frac{1}{2}$  per cent., the rate of increase is 11 microhms (see p. 89 and bottom of p. 94).

#### Group 7.—CHROMIUM STEELS.

Marks.	Percentage Composition.		Conductivity Copper = 100.		Specific resistance (calculated).	
	Cr	C	Unann.	Ann.	Unann.	Ann.
993	2·00	0·90	—	7·1	—	24·2
1177 I	3·25	0·43	4·8	6·9	35·55	24·9
„ N	9·50	1·09	4·0	4·5	43·45	38·2

The effect of added chromium in reducing the conductivity of iron appears to be nearly the same as that produced by nickel. Unfortunately the carbon as well as the chromium differs in the specimens tested, so the true effect of an increase of chromium in the alloy is doubtful. The large amount of carbon in the first and last specimens augments their resistance; nevertheless, even in this imperfect comparison, an increase of only 1·8 microhms for every 1 per cent. of added chromium is shown, *i.e.* for rich chromium steels: the rate of increase, as in other cases, is higher in alloys containing less chromium (see p. 88).

#### Copper Steels.

The last group in Class I. consists of alloys of iron and copper; of these, three specimens were tested. Other specimens of steels containing copper, along with one or more metals, will be found in Classes II. and III.; one of these, 1149 A, containing, besides copper, one per cent. of aluminium, is repeated here.

#### Group 8.—COPPER STEELS.

Marks.	Percentage Composition.			Conductivity Copper = 100.		Specific resistance (calculated).	
	Cu	C	Mn	Unann.	Ann.	Unann.	Ann.
1264 A	1·59	0·68	0·36	8·7	11·5	19·8	14·9
„ B	2·50	0·59	0·32	9·0	11·9	19·0	14·4
1263 C	2·87	0·17	1·04	8·0	9·8	21·5	17·4
1149 A*	3·75	0·04	0·16	6·9	8·1	24·9	21·0

\* 1149 A. has also one per cent. of aluminium.

Notwithstanding that copper is at least six times the conductivity of iron, alloying iron with a small percentage of copper does not appear to increase its conductivity materially, if at all. This indefinite conclusion is due to the fact that the specimens tested contained a large percentage of carbon or manganese (and 1149 A contained aluminium), so that the true conductivity of a pure alloy of copper and iron is not shown in these results. The only comparison possible is between 1264 A and B, where an increase of 0.9 per cent. of copper *diminishes* the resistance half a microhm, equivalent to 0.6 microhm for one per cent. of added copper; but even here this small decrease may be due to the rather lower carbon and manganese present in 1264 B.

These copper steels were drawn into wire (about No. 20 B. W. G.) and annealed, the specific resistance at 15° C.; and the temperature-coefficient between 10° C. and 120° C. of each specimen was then determined with the following results. The percentage composition is given in the preceding table, and the results are here arranged in the order of increasing resistance.

SPECIFIC RESISTANCE OF COPPER STEELS (Tested in Form of Wire).

Marks.	Specific resistance in microhms.	Percentage variation of resistance per 1° C.
1264 B	13.55	0.457
„ A	13.92	0.418
1263 C	16.15	0.366
1149 A	20.77	0.280

It will be noticed that the specific resistance of these annealed wires, as directly determined, agrees fairly well with the resistance as deduced from the conductivity of the same alloy in the form of a rod, given in the last column of the table in Group 8; the somewhat lower resistance in the former case is doubtless due to slight differences in the annealing of the two series of specimens.

For the convenience of those who prefer results given in terms of resistance rather than conductivity, the curves shown in fig. 6 have been drawn. Here the ordinates are sp. resistances in microhms per c.c. (at about 16° C.), and the abscissæ the various percentages of the elements named which were added to the iron. These curves are, of course, merely the reciprocals of those shown in Plate II., the results having been deduced from the conductivity in the manner already described (p. 72). As the determinations of the conductivity of the specimens in the annealed state were not finished when the figure was engraved, the

FIG. 6.—Curves showing Resistance of Unannealed specimens.

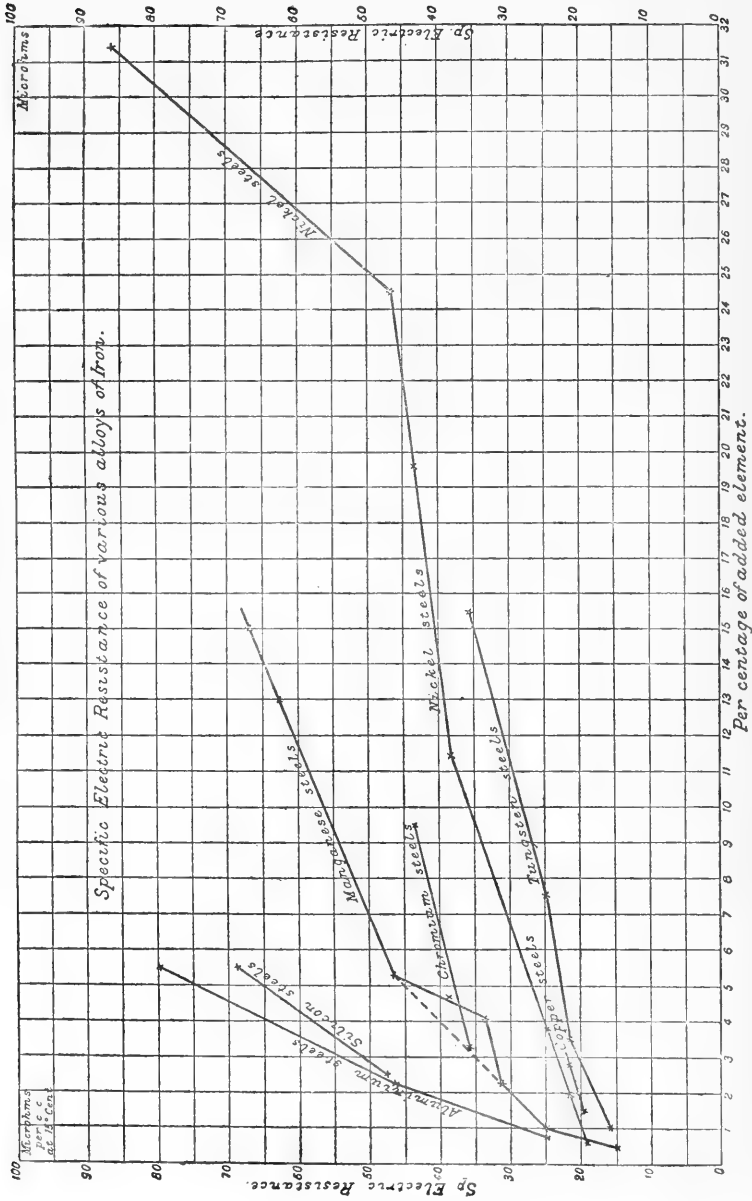

NOTE.—Curves of the later determinations of the *annealed* specimens, which give truer comparative results, will be given in a subsequent paper; or can be drawn from the tables in the present paper.



curves show the resistances in the *unannealed* condition. The effect of annealing is to lower the curves in each case. Some of the irregularities observed, notably the loop in the manganese steels, are smoothed out by annealing, and the position of the copper steels would then be slightly below that of the tungsten steels instead of above, as shown in fig. 6. It must be borne in mind that (1) owing to small irregularities in the sectional area of the rods, and (2) the disturbing influence caused by small variations in the amounts of carbon, silicon, and manganese unavoidably present in the alloys, the curves here shown can only be regarded as an approximate representation of the effect produced by varying amounts of different elements on the conductivity of these alloys of iron.

## CLASS II.

### Effect of two Elements added to Iron or Steel.

We now come to specimens which exhibit the effect of *two* elements added to iron or steel; and for the sake of comparison with the last group, which shows the effect of copper on the conductivity of steel, we will first give a specimen of an iron alloy containing *nickel* as well as copper. The comparison is of interest, as the alloy has practically the same amount of copper and carbon as 1263 C in Group 8, only with 5.75 of nickel added to it.

### Group 9.—NICKEL-COPPER STEEL.

Mark.	Percentage Composition.			Conductivity Copper = 100.		Specific resistance (calculated).	
	Ni	Cu	C	Unann.	Ann.	Unann.	Ann.
1252 B	5.75	2.75	0.18	4.3	4.5	40.0	38.2

It will be noticed that the addition of the nickel reduces the conductivity of the alloy one-half compared with a similar copper steel *without* nickel. In like manner, the addition of copper to a nickel steel reduces the conductivity of the alloy when compared with a similar nickel steel without copper. This may be seen upon referring to the nickel steel curve in Plate II. or fig. 6. We will now take other double alloys of steel where nickel is one of the elements.

Here is a group of alloys of nickel and chromium with iron, arranged in order of conductivity. Their conductivity, it will be noticed, is considerably lower than steels containing corresponding percentages of nickel alone.

## Group 10.—NICKEL-CHROMIUM STEELS.

Marks.	Percentage Composition.			Conductivity Copper = 100.		Specific resistance (calculated).	
	Ni	Cr	C	Unann.	Ann.	Unann.	Ann.
1286 A	2·75	0·75	0·25	6·9	7·2	24·9	23·9
1480	2·00	2·00	0·90	6·7	6·8	25·6	25·3
1286 C	2·50	1·75	0·31	4·9	6·2	35·1	27·7
1327 C	3·25	1·75	0·86	4·2	6·0	40·9	28·5
1210 D	2·50	4·50	0·41	4·0	4·9	43·0	35·1
*1450	12·24	2·01	0·64	3·1	3·3	55·2	52·1

The effect of chromium on the conductivity of these steels is well seen by comparing 1286 A and C, very similar alloys, except that the latter has 1 per cent. more chromium in it: an addition that increases the resistance 3·8 microhms. Compare also 1286 C and 1210 D, which mainly differ in the latter containing 2·75 per cent. more chromium—a difference that increases the resistance 2·6 microhms for each 1 per cent. of added chromium; the resistance increasing at a slower rate as the alloy becomes richer in chromium (cf. Group 7). The last specimen, 1450, has nearly 10 per cent. more nickel than the one preceding it, 1210 D, and also higher carbon and manganese, hence its conductivity is lower, notwithstanding the reduction of  $2\frac{1}{2}$  per cent. in the chromium. A much greater effect is produced on the conductivity by silicon added to a nickel steel, as follows:

## Group 11.—NICKEL-SILICON STEELS.

Marks.	Percentage Composition.			Conductivity Copper = 100.		Specific resistance (calculated).
	Ni	Si	C	Annealed.	Annealed.	
†1447 A	12·70	0·39	0·81	4·0	43·0	
†1447 B	12·10	0·56	0·97	3·8	45·0	
1103 A	3·25	2·00	0·38	3·9	44·0	
1102 A	1·00	2·00	0·79	3·4	50·5	
1103 C	3·50	3·25	0·22	3·0	57·4	

As was the case with the nickel chromium steels in Group 10, the large quantity of nickel present in the first two specimens above, 1447 A and B, has a less effect

\* This specimen also contained 0·54 per cent. of manganese.

† These two specimens also contained 0·61 per cent. of manganese.

on the conductivity than the much smaller quantities of silicon added to the other specimens. Compare also 1103 A and 1103 C, having nearly the same composition, except that the latter has 1.25 per cent. more silicon—an addition that increases the electrical resistance 10.7 microhms for each 1 per cent. of added silicon; whereas, in 1103 A and 1102 A, having the same quantity of silicon, the alloy 1103 A, containing 2.25 per cent. more nickel than 1102 A, has actually a higher conductivity. This is partly due to the fact that 1102 A has 0.41 per cent. more carbon in the alloy than 1103 A; and, as we have seen (p. 80), small percentages of nickel do not injure the conductivity of poor steels.\*

We now pass on to a very remarkable group, the *nickel-manganese* steels. It was found that excellent alloys could be made with large percentages of both these elements added to iron, and the result was a series of alloys, some of which were found to have an extraordinary electrical resistance.

#### Group 12.—NICKEL-MANGANESE STEELS.

Marks.	Percentage Composition.			Conductivity Copper = 100.	Specific resistance (calculated).
	Ni	Mn	C	Annealed.	Annealed.
1420 B	1.00	1.00	0.50	6.00	28.7
1254 C	4.00	3.75	0.57	3.65	47.5
1339	2.57	8.00	1.21	2.45	70.2
1313 C	9.00	10.25	1.40	2.30	74.7
1109 D	14.55	5.04	0.80	2.05	83.0
1414 A	19.00	5.04	0.60	2.10	82.0
1414 B	25.00	5.04	0.60	1.93	89.2
1449 A	31.40	0.82	0.70	2.00	86.0
1449 E	30.00	1.50	0.60	1.95	88.2

The conductivity of 1414 A is rather higher than 1109 D, though it contains  $4\frac{1}{2}$  per cent. more nickel; tested by the file, it was harder than 1109 D: this may be due to a difference in thermal treatment, as the rod 1109 D was "water toughened."

Several of these specimens were drawn into wire, so that their sp. resistances

\* It is of course impossible to plot the relation between the conductivity and composition of these compound alloys, in the form of curves such as are given in Class I., owing to the variation in each of the two or more elements added to the steel.

could be more accurately determined and the variation of resistance with temperature ascertained. Here is the result:—

SPECIFIC RESISTANCE OF NICKEL-MANGANESE STEELS (Tested in the Form of No. 20, B. W. G. Wire).

M. rks.	Specific resistance in microhms at 15° C.	Percentage variation of resistance per 1° C., between 0° and 150° C.
1420 B	28·63	0·150
1109 D	83·11	0·109
1449 A	86·60	0·090
*1449 E	89·17	0·077
1414 A	90·62	0·104
1414 B	97·52	0·085

The specific resistance of most of these alloys is practically the same in the form of wire as that deduced from the conductivity of the rods of similar specimens. The considerably larger resistance of the last two specimens given in the above table is due to the particular samples from which the wires were drawn containing rather more carbon: viz. 1414 A wire had 1 per cent. of carbon; and 1414 B wire was found to have 1·18 per cent. of carbon, nearly double the amount of that in another earlier casting from which the rods were made.

The sp. resistance of the wire 1414 B is the largest yet found in any of these alloys of iron; and we believe it has the highest resistance of any metallic conductor yet obtained as wire in a commercial form. It is sixty times greater than the resistance of pure copper, nearly ten times as great as the best iron (S.C.I.), and  $4\frac{1}{2}$  times greater than German silver.

The temperature coefficient of these two alloys, 1414 A and B, and also of 1449 A and E was found to be fairly low, being less than a sixth of that of iron, and not very much greater than German silver. Hence these alloys, if they do not deteriorate with use, will prove extremely valuable materials for resistance coils and for the purpose of electric-heating. We have not put them to a prolonged test, but so far as our observations have gone they do not appear to undergo any serious change by moderate heating and cooling.†

Turning to the analysis of these nickel-manganese steels given in Group 12 (p. 89), it will be observed that 1109 D, 1414 A, and 1414 B contain the same percentage of manganese, differing mainly in the amount of nickel. 1414 A

\* This alloy was received and tested in the form of strip.

† Upwards of four years have elapsed since the nickel-manganese alloy, 1109 D, now known as reostene, was made by one of us; its electric resistance, determined by us on November 8, 1895, was found to be 83 microhms per c.c., with a temperature variation of a little over 0·1 per cent. Various samples of reostene have been made, and the resistance measured by us from time to time with

contains  $4\frac{1}{2}$  per cent. more nickel than 1109 D, and 1414 B has 6 per cent. more nickel than 1414 A. Taking the sp. resistances of these in the form of wire (being in similar condition), and comparing the increase in resistance for each 1 per cent. of nickel added to the alloy, we find a very similar result to that given previously from the measurements in Group 3. On p. 80 we found that, in alloys of iron containing from 1 to 11 per cent. of nickel, the average increase of resistance for each 1 per cent. of added nickel was 1.6 microhms. From Group 12 we see that in composite steels, containing from 19 to 25 per cent. of nickel, the increase of resistance for each 1 per cent. of added nickel is 1.2 microhms, between these limits the same rate will be found on referring to Group 3, p. 78. From Groups 3 and 12 we get the following:—

Percentages of Nickel in alloy.	Average increase of specific resistance for each 1 per cent. of added nickel.
From 1 to 4 per cent.	2.2 microhms.
„ 1 „ 11 „	1.6 „
„ 19 „ 25 „	1.2 „

This indicates a continuous reduction in conductivity produced by nickel, when added to alloys of iron, even up to very large percentages, though, as already stated, the effect of small quantities of nickel in steel is not nearly so great as that of manganese, silicon, or aluminium.

Having examined the conductivity of the nickel-manganese, or manganese-nickel steels, we will now take a series of specimens where other elements besides nickel are added to manganese steels. Here is a group of manganese chromium steels.

#### Group 13.—MANGANESE-CHROMIUM STEELS.

Marks.	Percentage Composition.			Conductivity Copper = 100.		Specific resistance (calculated).	
	Mn	Cr	C	Unann.	Ann.	Unann.	Ann.
1274 A	3.00	5.00	1.15	2.50	3.6	68.3	47.8
1430	3.09	8.92	1.30	3.40	4.7	50.6	36.6
1233 A	2.60	9.22	1.36	2.48	2.7	69.4	63.7
620	17.50	3.50	0.88	2.20	2.5	79.3	68.8

the same result; the substance has been submitted to prolonged and repeated heating and cooling for upwards of three years, in most cases no sensible deterioration of the material has been noticed. For some time past all the resistance coils in the electric installation of the Royal College of Science have been replaced by reostene with a great saving of space and economy of material. Some specimens of thin reostene wire have, however, undergone a molecular change and become brittle and useless.—W.F.B.

The carbon is high in all these specimens. In the first three specimens the percentages of manganese and of carbon remain about the same, the amount of chromium in each differing; the conductivity it will be seen is very low in all.

From the chemical analysis we should expect to find the conductivity of 1274 A higher than that of 1430, but the reverse is the case, confirmed after several trials. This is, no doubt, due to the difference in hardness, as the latter is distinctly softer to the file than the former.

Annealing makes a great difference in the conductivity of these manganese chromium steels, *e. g.* 1430 in the unannealed state had a conductivity of 3·4, whilst in the annealed state it was 4·7, taking copper as 100. This difference is still more striking in the magnetic permeability of this specimen in the two states (see p. 114). The alloy, 1233 A, is enormously hard, and can hardly be touched by a file.

The next is a series of manganese-tungsten steels.

#### Group 14.—MANGANESE-TUNGSTEN STEELS.

Marks.	Percentage Composition.			Conductivity Copper = 100.		Specific resistance (calculated).	
	Mn	W	C	Unann.	Ann.	Unann.	Ann.
687	2·25	3·25	0·40	4·7	6·2	37·1	27·7
683	3·25	10·00	1·52	3·8	5·5	45·4	31·3
1343 B	10·20	2·11	1·08	2·4	2·6	71·3	65·8
1343 A	11·10	2·85	1·34	2·3	2·5	74·5	68·4

Tungsten, it will be remembered, had the least effect of any element, so far tried, in reducing the conductivity of steel; the addition of manganese to the tungsten steels produces a great drop in the conductivity, as will be seen by comparing 687 above, with 1294 H in Group 4. Compare also the manganese steel 53 in Group 2 with the specimen 687, having the same quantity of manganese and carbon; the effect of 3¼ per cent. of tungsten added to the latter *raises* the conductivity when both specimens are annealed. The same remarkable increase in conductivity will be seen by comparing 683 with 1381 in Group 2, Series B; in the former 10 per cent. of tungsten has been added to a manganese steel. Note also the effect of practically reversing the amounts of tungsten and manganese in the specimens 683 and 1343.

The next group exhibits the effect of adding silicon to manganese steel.

## Group 15.—MANGANESE-SILICON STEELS.

Marks.	Percentage Composition.			Conductivity Copper = 100.		Specific resistance (calculated).	
	Mn	Si	C	Unann.	Ann.	Unann.	Ann.
611	0.58	0.49	0.58	7.5	8.3	23.1	20.7
1379 D	10.08	0.63	0.16	2.6	2.8	65.5	61.1
601	2.00	4.25	0.40	2.3	2.5	73.8	68.4

Other low manganese-silicon steels are given in Groups 1 and 3, Series B, from which 611 is transferred for comparison, and 1379 D is also transferred from Group 2, Series B. By comparing 601 with 687 in Group 14, or with 53 in Group 2, p. 76, it will be seen how powerfully silicon affects the conductivity of steel.

In the next group we see the effect of adding copper to manganese steel.

## Group 16.—MANGANESE-COPPER STEELS.

Marks.	Percentage Composition.			Conductivity Copper = 100.		Specific resistance (calculated).	
	Mn	Cu	C	Unann.	Ann.	Unann.	Ann.
1240	2.0	1.5	0.25	5.8	6.8	29.5	25.2
1260 A	8.0	2.75	0.64	2.4	3.3	71.4	51.8

From Group 2 it will be seen that a steel (53), having  $2\frac{1}{4}$  per cent. of manganese, but no copper, has rather a lower conductivity than 1240 in the above table; the carbon it is true is rather lower in the latter specimen.

We will now examine the effect of adding a second metal to the chromium steels. Here is a group of chromium-aluminium steels.

## Group 17.—CHROMIUM-ALUMINIUM STEELS.

Marks.	Percentage Composition.			Conductivity Copper = 100.		Specific resistance (calculated).	
	Cr	Al	C	Unann.	Ann.	Unann.	Ann.
1178 B	1.75	0.75	0.21	5.2	6.1	33.2	28.0
1179 B	3.50	1.00	0.46	3.4	3.8	49.9	45.0
1178 D	1.50	2.50	0.18	2.9	3.4	58.5	50.3
1178 E	1.50	4.50	0.22	2.2	2.5	77.8	68.4

Comparing 1178 B with 1167 D in Group 5, which has the same amount of aluminium, it will be seen that the addition of 1.75 per cent. of chromium reduces the conductivity only 20 per cent. The greater effect produced by aluminium than by chromium in lowering conductivity is seen by comparing 1179 B and 1178 D. The specimens marked 1178 are similar chromium steels to which varying amounts of aluminium have been added. The increase of resistance thereby produced is very marked, between 1178 B and 1178 E the resistance increases at the rate of 11 microhms for 1 per cent. of aluminium added to these chromium steels, practically the same increase produced by the aluminium as when the chromium was absent (see p. 83). This rate is taken between 0.75 and 4.5 per cent. of added aluminium; between 0 and 1 per cent. the rate of increase of resistance is still higher, as might be expected. By comparing the resistances of the aluminium steels in Group 5, p. 83, with each other, and with a corresponding carbon steel *without* aluminium, the rate of increase of resistance for 1 per cent. of aluminium added to iron will be found almost the same as the rate deduced from these composite steels. The following table shows these results:—

Percentage of Aluminium in Alloy.		Average increase of specific resistance for each 1 per cent. of added aluminium.
From 0	to 2.0 per cent.	12 microhms.
„ 0	„ 4.5 „	11 „
„ 0	„ 5.5 „	10 „
„ 2.25	„ 5.5 „	9.5 „

The next group shows the effect of adding silicon to chromium steels.

#### Group 18.—CHROMIUM-SILICON STEELS.

Marks.	Percentage Composition.			Conductivity Copper = 100.		Specific resistance (calculated).	
	Cr	Si	C	Unann.	Ann.	Unann.	Ann.
518	2.0	1.00	0.76	4.70	5.4	36.4	31.8
517	2.0	1.80	0.86	3.40	3.9	51.0	44.1
1185 F	3.5	2.25	0.54	3.14	3.4	54.8	50.6

The enormous increase in resistance due to silicon is seen by comparing 517 and 518; also by referring to 1177 I in Group 7, a similar chromium steel to 1185 F, but without the silicon. This comparison shows that the rate of increase for each 1 per cent. of added silicon is 15 microhms between 1 and 1.8 per cent. of silicon, and 11 microhms between 0 and 2.25 per cent. of silicon.



The two next specimens show the effect of adding first copper and then tungsten to chromium steel; whilst the effect of the addition of both copper and tungsten to a chromium steel is given in Group 25.

## Group 19.—CHROMIUM-COPPER STEEL.

Mark.	Percentage Composition.			Conductivity Copper = 100.		Specific resistance (calculated).	
	Cr	Cu	C	Unann.	Ann.	Unann.	Ann.
1255 A	5·75	1·8	0·85	4·1	5·5	42·7	31·2

## Group 20.—CHROMIUM-TUNGSTEN STEEL.

Mark.	Percentage Composition.			Conductivity Copper = 100.		Specific resistance (calculated).	
	Cr	W	C	Unann.	Ann.	Unann.	Ann.
1189 B	0·75	2·0	0·25	7·66	9·6	22·5	17·9

Whilst the addition of small percentages of copper and tungsten do not much affect the conductivity of chromium-steel, it will be seen by comparing 1264 A in Group 8 with 1255 A in Group 19, that the addition of chromium to a copper steel largely reduces its conductivity.

The effect of adding 3·75 per cent. of copper to a low aluminium steel has practically no effect in altering the conductivity, as will be seen by comparing the next specimen with 1167 D in Group 5.

## Group 21.—ALUMINIUM-COPPER STEEL.

Mark.	Percentage Composition.			Conductivity Copper = 100.		Specific resistance (calculated).	
	Al	Cu	C	Unann.	Ann.	Unann.	Ann.
1149 A	1·0	3·75	0·04	6·9	8·1	25·0	21·0

On the other hand, the addition of 2·25 per cent. of silicon doubles the resistance of a low aluminium steel, as seen by comparing 1167 D, p. 83, with 803 below.

## Group 22.—ALUMINIUM SILICON STEEL.

Mark.	Percentage Composition.			Conductivity Copper = 100.		Specific resistance (calculated).	
	Al	Si	C	Unann.	Ann.	Unann.	Ann.
803	0·5	2·25	0·67	3·54	4·0	48·6	43·0

## CLASS III.

## Effect of three or more Elements added to Iron or Steel.

This class exhibits the effect of the addition of three or four elements to steel.

## Group 23.—COBALT-MANGANESE-SILICON STEELS.

Mark.	Percentage Composition.				Conductivity Copper = 100.		Specific resistance (calculated).	
	Co	Mn	Si	C	Unann.	Ann.	Unann.	Ann.
1209 C	1.8	1.0	0.64	0.25	6.3	7.4	27.3	23.2
1209 F	7.0	0.8	0.80	0.52	5.1	5.6	33.6	30.7

Hitherto no alloys of steel have been examined containing cobalt; the effect on the conductivity produced by the addition of this element closely resembles that produced by nickel, as will be seen by comparing this group with Group 3, p. 78.

The next specimens show the effect of adding copper to a nickel-manganese steel and to a chromium-tungsten steel.

## Group 24.—NICKEL-MANGANESE-COPPER STEEL.

Mark.	Percentage Composition.				Conductivity Copper = 100.		Specific resistance (calculated).	
	Ni	Mn	Cu	C	Unann.	Ann.	Unann.	Ann.
1261 A	2.9	1.5	2.9	0.17	5.3	6.9	32.7	24.9

## Group 25.—CHROMIUM-TUNGSTEN-COPPER STEEL.

Mark.	Percentage Composition.				Conductivity Copper = 100.		Specific resistance (calculated).	
	Cr	W	Cu	C	Unann.	Ann.	Unann.	Ann.
1249 A	1.75	2.0	2.0	0.48	3.5	5.5	49.0	31.3

This alloy 1249 A was drawn into wire and its specific resistance directly measured in the annealed state, together with its temperature coefficient. The specific resistance at 16° C. was found to be 31.6 microhms per c.c. As will be seen, this result closely agrees with that deduced from its conductivity in the form of a rod. The percentage variation of resistance of this alloy per 1° C. was found to be 0.204 between 10° and 150° C.

## Group 26.—CHROMIUM-MANGANESE-SILICON STEEL.

Mark.	Percentage Composition.				Conductivity Copper = 100.		Specific resistance (calculated).	
	Cr	Mn	Si	C	Unann.	Ann.	Unann.	Ann.
608	2.0	4.25	1.5	1.32	2.5	3.3	68.6	52.1

## Group 27.—NICKEL-MANGANESE-ALUMINIUM STEEL.

Mark.	Percentage Composition.					Conductivity Copper = 100.		Specific resistance (calculated).	
	Ni	Mn	Al	Si	C	Unann.	Ann.	Unann.	Ann.
1411	14.1	5.3	2.3	0.61	0.43	1.94	3.6	88.7	47.8

The above alloy, 1411, exhibits a remarkable increase of conductivity by annealing, amounting to no less than 87 per cent., notwithstanding the curious fact that the annealed specimen was harder to the file than the unannealed. Two sample rods of this alloy were made, one being annealed and the other unannealed, and their conductivities found as above; these were then reversed in their heat treatment, the unannealed specimen being annealed by slow cooling, and the annealed specimen heated and cooled quickly; on re-determining their conductivities a year later, precisely the same results were obtained as those given above, the now annealed specimen again being the harder of the two to the file. There was a considerable want of homogeneity in the physical condition of this annealed rod, one-half having a higher conductivity than the other. The mechanical and physical properties of these composite nickel steels need thorough investigation, as the results promise to be most interesting.

## Group 24 a.—NICKEL-MANGANESE-COPPER STEEL.

Mark.	Percentage Composition.				Conductivity Copper = 100.		Specific resistance (calculated).	
	Ni	Mn	Cu	C	Annealed.	Annealed.	Annealed.	
1424 B	14.44	5.9	2.25	0.83	2.15	80.0		

This specimen, 1424 B, should have been included in Group 24 on the last page: an error, made by the clerk who transcribed the chemical analysis, was not discovered until after the Paper had gone to press. The specimen turns out to be, as the high electric resistance indicated, a nickel-manganese steel, similar to 1109 D in Group 12, p. 89, to which  $2\frac{1}{4}$  per cent. of copper has been added. The effect of this addition is to reduce the resistance slightly.

### Conclusions.

A complete summary and discussion of our results will be given in a subsequent paper, when our experiments, which are still in progress, are more complete. Exact results can only be obtained from a series of specimens where the impurities are either absent, or small and constant in amount; and also where the specimens are in the form of wires or rods turned to a uniform diameter throughout their length, the physical state and prior heat-treatment of each specimen being alike. Although it is difficult to obtain all these conditions, we hope, by a proper selection from a large number of analysed specimens, which have been carefully annealed and turned down to a uniform cross-section, eventually to approach more nearly to an ideal series. So far, however, our results have shown that:—

(1) In all cases a larger, and in some of the alloys a very much larger, increase in electric resistance is produced by the first additions of the added element than for similar amounts added after the alloy is rich in that particular element.

(2) The increase in the electric resistance of iron produced by alloying it with an equal percentage of different elements varies through a wide range, according to the nature of the added element; but this increase of resistivity does not appear to be connected with the specific resistance of the added metal.

(3) Taking the specific electric resistance of mild steel, or of iron containing approximately the same amount of impurities as are present in the alloys we have tested, to be about 15 microhms per c.c. at the temperature of the air, then the addition of corresponding amounts (say 3 per cent.) of the following metals raises the resistance in the case of annealed alloys of iron and

3 per cent of	Tungsten	to about 17,	or an increase of 2 microhms.
„	Nickel	„ 21,	„ „ 6 „
„	Chromium	„ 24,	„ „ 9 „
„	Manganese	„ 30,	„ „ 15 „
„	Silicon	„ 45,	„ „ 30 „
„	Aluminium	„ 48,	„ „ 33 „

With a corresponding alloy of iron and copper, no increase but probably a slight decrease in resistance is produced. No carbon steels containing a corresponding percentage of carbon have been tested; but for very small additions, of under one per cent., the increase of resistance produced in pure iron by the presence of carbon appears to be greater than that caused by the addition of a corresponding amount of any other element.

Why the conductivity of a metal is so much reduced by the presence of a small quantity of certain other elements, and why the effect of these elements should vary in the order we have found, are problems that await explanation. Whether the results are due to the production of a back electro-motive force from the contact of dissimilar elements in the alloy, as suggested by Lord Rayleigh, or to the intermixture of badly-conducting particles produced by the chemical union of a portion of the metal with the added element, or to other causes, are questions upon which our experiments will, we hope, ultimately throw some light. Our results appear to give some support to Lord Rayleigh's conjecture; it will, moreover, be observed that the greatest increase in resistance is produced by the addition of those elements having the lowest atomic or molecular weight. We hope to return to this question in another paper.

Some experiments on the electric resistance of various alloys of iron or steel have recently been made by M. Le Chatelier, and are published in the *Comptes Rendus* for June 13th, 1898. The specimens he used were in the form of short bars, 20 cms. long, and of square section, 1 cm. on the side. The total number of specimens was not very large, and the amount of impurities present in some of them was considerable. M. Le Chatelier finds that the increase of resistance in steel produced by adding one per cent. of the following bodies to iron is:—for silicon, 14 microhms; carbon, 7; manganese, 5; nickel, from 3 to 7 microhms; and for one per cent. of chromium, tungsten, or molybdenum the increase of resistance produced was very small. These results, however, are obtained by taking the increase of resistance between the lowest and highest percentages of the added element in each series of alloys; as the limiting percentages in the specimens examined by M. Le Chatelier were widely different (varying from 0.06 to 1.6 per cent. in the case of carbon, and 0.24 to 13 per cent. in the case of manganese), his results are not strictly comparable with each other. We find, however, that the resistance he obtained for particular specimens is practically the same as that found by ourselves for a similar alloy, with approximately the same amount of impurities.

The late Dr. Hopkinson, F.R.S., also determined the electric resistance of a few specimens of manganese, silicon, chromium, and tungsten steels, which had been subject to different thermal treatment. The general order of conductivity he found agrees with our results, and so does the specific resistance of particular specimens, when those of approximately the same composition and in the same physical state are compared. Nearly all Dr. Hopkinson's specimens had, however, a much higher percentage of impurities than ours, and hence had a resistance above the normal: see *Phil. Trans.*, 1885, Part II., p. 463.

## PART II.

## MAGNETIC PROPERTIES.

In order to examine the magnetic properties of these alloys it was necessary—if complete **B** and **H** curves were to be obtained in each case—to adopt a method that would not consume too much time, and also one that would not involve the making of another set of specimens, which in some cases would have been difficult.

The specimens were accordingly made, as already stated, in the form of rods as long and slender as could be conveniently obtained. In this form both the electric and magnetic resistance could be readily determined. It would have been better to have had the rods of smaller diameter, but this was found to be impracticable in many of the alloys. As, however, the length of all the rods was about 200 times their diameter, the demagnetising reaction due to the poles in

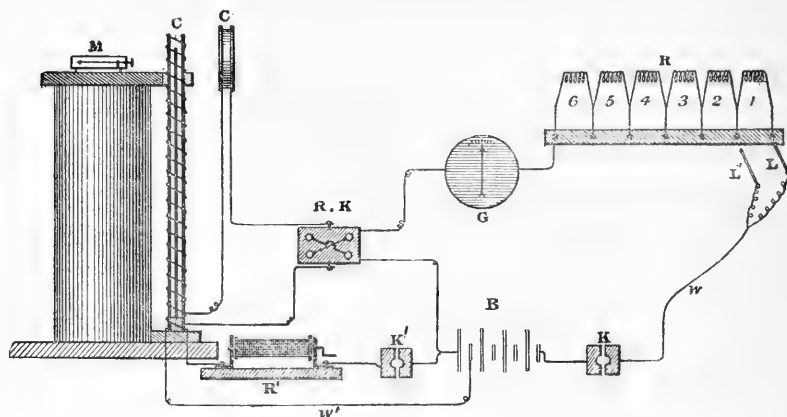

FIG. 7.

most cases was small, inasmuch as the permeability of the majority of the specimens was considerably less than that of iron, varying in fact down to a practically non-magnetic alloy.\* It was this great range in the permeability of the specimens, as well as in their number, which led us to adopt the following magnetometric method of measurement.

A diagrammatic view of the general arrangement of the apparatus is shown in fig. 7. The magnetometer **M** was supported on a solid stone pillar; after various trials the most convenient magnetometer was found to be that used on Lord

\* Experiments were made to compare the **B** and **H** curves obtained by our method of magnetometric measurement, with the results obtained by a ring formed of the same material, using the ballistic method of measurement. A certain correction is necessary for our rods in specimens of high permeability (see footnote, p. 106, and Note A, p. 125).

Kelvin's graded galvanometers.\* One great advantage of this instrument was the ease with which its range could be altered by sliding it to or from the solenoid on a grooved board, or by the addition of an over-head magnet, by means of which the strength of the field at the magnet could be increased by a known amount. The field-magnets usually employed on the instrument were too strong for our purpose, and we had two smaller ones specially made. The strength of these were found to be 0.875 and 2.927 C.G.S. units respectively. These, with the Earth's field, as carefully determined at the place of observation, viz. 0.175 C.G.S., gave us three convenient grades. The standard distance of the magnetometer needle from the upper pole of the rod under test was 45 cms. This distance, in the case of a few of the less permeable steels, was reduced to either 20.9 cms. or 14.75 cms.; these distances being chosen because the deflections, when divided by 5 or 10, respectively, corresponded to those at the standard distance. This ratio, obtained by calculation, was verified by actual experiment at the different distances.

The test-rod was supported vertically, as shown in fig. 7, inside the magnetising solenoid C. The latter was 120 cms. long and 1.7 cms. mean diameter, and wound with 2886 turns of No. 18 B.W.G. double-cotton-covered copper wire, in four layers. This was sufficient to carry a current of 10 ampères for a short time without undue heating. The resistance of the coil was 2.15 ohms, and the magnetising force was 30.2 C.G.S. units per ampère.

In order to neutralize the effect on the magnetometer of the magnetic field due to the solenoid, a compensating coil, C',† was introduced into the circuit, so that the main current passed through it as well as the solenoid. By trial, on moving the compensating coil to and fro, a point of neutralization was found, so that, when no test-rod was present, the magnetometer needle remained unaffected whatever strength of current traversed the solenoid. Any magnetisation of the rods due to the vertical component of the Earth's magnetic field was neutralized by a single layer of wire round the solenoid, through which a small independent current from a single cell was sent by the circuit W'. The strength of this current was adjusted to suit the particular rod under test by means of the rheostat R', or it could be intercepted altogether by the plug key K', as it was not required in the specimens of low permeability.

The main magnetising current was obtained from 1 to 5 cells of a storage battery B, and after traversing the plug key K, and circuit W, entered a series of

\* This magnetic system is composed of four small magnetic needles, about 1 cm. long each, with their poles turned in similar directions, and supported on an iridium-tipped point and sapphire cap. The pointer is an aluminium index, about 9 cms. long, working over a tangent scale.

† In fig. 7 this is also marked C by mistake. The relative distances of the compensating coil and the magnetometer from the solenoid were much greater than would appear from the diagram.

resistances  $R$  by means of the terminal  $L$ . The resistance coils, marked 1 to 6 in the above fig. 7, had values of 41, 10, 5, 3.8, 0.94, and 0.54 ohms, respectively, and were connected with a series of mercury cups. When  $L$  was in the position shown in the diagram, the whole of the resistances were in circuit; then, by inserting the second terminal  $L'$  into the next mercury cup and removing  $L$ , the magnetising current was suddenly increased without any interruption of the circuit. Again, by putting  $L$  into the third mercury cup, and removing  $L'$ , the next step up in the magnetising current was made, and so on, till all the coils were cut out and the maximum magnetising current reached; the process was then repeated backwards, stepping down till all the resistances were again in, when the circuit was broken by removing  $L$ . The reversing key  $R K$  was then thrown over, and a second series of steps up and of steps down were made; the current was then once more reversed, and a third series of like steps made; this completed the cycle for that one rod. Between each of the steps one observer read the deflections on the magnetometer  $M$ , and another read the strength of the magnetising current as measured by a pair of direct reading Weston ammeters, and a Kelvin magneto-static ampèremeter, one of which is shown diagrammatically at  $G$ . One of the Weston instruments was graduated to read 0.001 ampère per division, and the other to read 0.05 ampère per division, while the magneto-static read 0.2 ampère per division. These three instruments thus gave us a continuous scale measuring from 0.001 ampère up to 18 ampères, the Weston ammeters being switched out whenever the current became too large for their respective ranges. Before use, these instruments were carefully tested by means of a Kelvin standard ampère balance.

In order to reduce the rod under test to a non-magnetic state before putting it through the cycle, the reversing key was rapidly oscillated by one observer, whilst another (by shifting the terminals  $L L'$  up and down the mercury cups) threw a gradually increasing or decreasing magnetising current round the solenoid; by this means each test-rod could, in a very short time, be reduced to a neutral state, as shown by the magnetometer needle returning exactly to its zero position. Each rod that was tested was taken through a complete magnetic cycle, with a maximum magnetising force of 45 C.G.S. units. This involved a total of 36 steps in each experiment.

The effect of the various series of steps will be better seen by referring to fig. 8, where the axes  $OH$  and  $OB$  represent, respectively, the magnetising force and the induction produced. The first series of steps up gives the initial curve 1, starting from the origin  $O$ ; the next series down gives the part 2 from the point of greatest induction to where the curve meets the axis  $OB$ ; the circuit is now broken and the current reversed; the next series of steps up gives that part of the curve marked 3, 3, cutting the axis  $OH$ , and extending down to the other



point of maximum induction, and another series down gives the part 4 to where the curve cuts the axis  $OB$  again; the circuit is again broken and the current reversed, and the last series of steps up gives the part of the curve marked 5, 5. This completes the cycle, but another series of steps down was always taken, —*i.e.* repeating the portion 2 of the curve—and finally another series of steps up, corresponding to the upper part of 3, so as to leave the rod in a practically non magnetic state, thus saving time if we found that its cycle had to be repeated. In every case the whole cycle was gone over again, if by inspection of our observations we found any discrepancy between the upper and lower halves of the cycle, that is if the cyclic curve was not perfectly symmetrical above and below the axis  $OH$ . In the plates appended to this paper the position of the cycle below the axis of  $OH$  is therefore omitted. The initial curve 1, fig. 8, is shown in all the plates as a finer line than the continuous cycle of the particular specimen, but represented in the same kind of dotted or continuous curve. For convenience of comparison the  $B$  and  $H$  curve obtained for our standard rod of iron is reproduced in all the plates.

The *residual induction* of the specimen is expressed by the distance  $OR$  (fig. 8); that is to say, the induction which remains in a very long thin rod after the magnetising current is removed: for brevity we will call this the *retentivity*.\* The *coercive force*

is expressed in terms of  $H$  by the distance  $OC$ ; that is to say, the magnetising force required to demagnetise the specimen. The magnetic *permeability* of the specimen varies, of course, with the magnetising force employed, and is expressed by the ratio of the induction  $B$  to the magnetic field  $H$  at any given point. The *hysteresis* loss can be deduced from the areas enclosed by the  $B$ - $H$  curves.†

\* As the residual induction increases with the maximum induction the *ratio* of these two quantities is, strictly speaking, the *retentivity*. The *coercive force* also rises with the maximum induction.

† For the measurement of most of these areas we are indebted to Mr. R. L. Wills, a former senior student in the Physical Laboratory of the Royal College of Science, Dublin, now working in the Cavendish Laboratory, Cambridge, as an 1851 Science Research Scholar. We must also acknowledge the useful assistance rendered to us in the laborious determination of these  $B$  and  $H$  curves by Mr. Wills, in conjunction with Mr. R. G. Allen, another Research student in the Physical Laboratory of the Royal College of Science, Dublin.

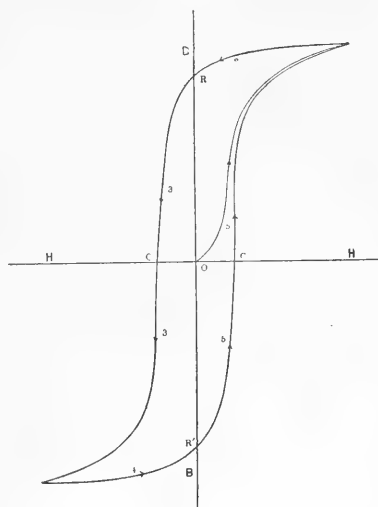

FIG. 8.

The following is an example, taken at random, of the readings obtained in going through a complete cycle for one of the specimens; from these readings the data necessary for plotting one of the curves given in Plates III.–IX. are obtained.

TABLE I.—(MARK 1179 B, PLATE VIII.) *Chromium-Aluminium Steel.*

Steps.	Magnetising current.	Magnetometer Readings.		
		Current direct.	Current reversed.	Current direct.
0	0·00	0·0	+ 19·7	- 20·0
Up 1	0·07	+ 0·3	+ 17·0	- 17·2
2	0·18	+ 2·0	+ 9·3	- 9·7
3	0·31	+ 11·3	- 5·1	+ 6·1
4	0·50	+ 19·9	- 18·2	+ 18·2
5	0·94	+ 27·0	- 26·6	+ 26·3
6	1·19	+ 28·3	- 28·2	+ 28·8
7	1·50	+ 29·9	- 30·0	+ 30·2
Down 6	1·19	+ 29·8	- 29·7	
5	0·94	+ 29·0	- 29·0	
4	0·50	+ 27·0	- 27·0	
3	0·31	+ 25·7	- 25·7	
2	0·18	+ 23·9	- 24·0	
1	0·07	+ 22·0	- 22·0	
0	0·00	+ 19·7	- 20·0	

Column 1 gives the number of the steps, first up and then down, as already explained, p. 102. Column 2 gives the magnetising current round the coil in ampères; these numbers multiplied by 30·2—the magnetic force of the coil per ampère—give the magnetic force  $H$ , acting on the rod in C.G.S. units. Columns 3, 4, and 5 give the magnetometer readings corresponding to the currents named in column 2; the sign + means a reading to the right of zero, and the sign - a reading to the left of zero. In columns 3 and 5 the current through the magnetising coil is in one direction; in column 4 it is reversed. Referring to fig. 8, the initial uprising curve 1 is obtained from the magnetometer readings enclosed within the first bracket in column 3; the position of the curve 2 in fig. 8 is obtained from the readings in the second bracket in column 3; the current is now reversed, and the portion of the curve 3 in fig. 8 is obtained from the first bracket in column 4, and so on till the cycle is complete. The symmetry of the curves is shown by the similarity, for corresponding currents, of the magnetometer readings in the first brackets in columns 4 and 5, and the second brackets in columns 3 and 4.

The magnetometer readings multiplied by a factor give the magnetic induction  $\mathbf{B}$ . This factor varies with each specimen, as it depends on the diameter of the rod under test and the directive force  $F$  at the magnetometer; the length of the rod, 102 cms., is the same in all cases, and the distance between the poles was, in general, 95 cms. The magnetometer scale was such that each division corresponded to an angle whose tangent was = 0.0227, *i.e.*  $\tan \theta = 0.0227 \times$  magnetometer reading. As  $\mathbf{B} = 4\pi\mathbf{I} + \mathbf{H}$ , and the intensity of magnetisation

$$\mathbf{I} = \frac{4r^2 F \tan \theta}{\pi l^2 \left\{ 1 - \left( \frac{r'}{r} \right)^3 \right\}}$$

where  $r$  = distance from upper pole of rod to magnetometer,

$r'$  = " " lower " " "

$d$  = diameter of rod in cms.,

$F$  = directive force at magnetometer,

$\theta$  = angle of deflection of magnetometer needle,

we thus get the value of  $\mathbf{I}$  per scale division of the magnetometer. Inserting the actual values for the particular specimen given (1179 B) in Table I., we have

$$\mathbf{I} = \frac{4 \times 45^2 \times .175 \times .0227}{\pi \times .54^2 \times .921} = 38.1.$$

Taking the highest current given in column 2, Table I., *viz.* 1.5, we have

$$\mathbf{H} = 1.5 \times 30.2 = 45.3;$$

as the magnetometer reading for this magnetising force was 30.0, we have

$$\mathbf{I} = 38.1 \times 30.0 = 1143,$$

therefore

$$\mathbf{B} = 4\pi \times 1143 + \mathbf{H} = 14400.$$

This gives the *maximum induction* of this particular chromium-aluminium steel for a magnetising force of 45.3 C. G. S. units. The *retentivity*, after this force, is shown by the residual induction in the cycle when the current is zero. From columns 4 and 5 in Table I., we see that the mean magnetometer readings on either side of zero is 19.85 for zero current. Working out this value as above, we get  $\mathbf{B} = 9500$ . The *coercive force* of this steel, in terms of  $\mathbf{H}$ , is found where the curve cuts the axis of  $\mathbf{H}$ : here the induction is zero. From Table I., it will be seen that this point lies between the steps up 2 and 3,—*i.e.* when the current is between 0.18 and 0.31 ampère, exactly 0.265 ampère. This current  $\times 30.2$  (the magnetic force of the coil per ampère) = 8 C.G.S. units.

Turning now to Plate VIII., we see from the curve for 1179 B, that

when **H** is 45, **B** is a little over 14,000,

when **H** is 0, **B** is 9500,

when **B** is 0, **H** is 8.

We will now proceed to give a tabulated statement of the results obtained for these three magnetic properties, and will first take those carbon steels we have tried. The **B** and **H** curves for this series were drawn, but are not given in the plates, as there is no particular novelty about them, and are retained until the series is more complete. A more detailed analysis of these and the other steels is given under the respective groups in Part I.; all that is here given is the percentage of the principal element or elements added to the iron. The test rods were, as already stated, 102 cms. long, and varied in diameter from 0·54 to 0·56 cm.\*

Unless otherwise stated, the determinations *in all cases* refer to specimens in the *annealed* state.†

TABLE II.—*Carbon Steels.*

Mark.	Per cent. of carbon.	Max. induction for <b>H</b> = 45.	Retentivity in terms of <b>B</b> .	Coercive force in terms of <b>H</b> .
B	0·03	17480	7120	1·66
L.S.S.	0·05	16920	7400	1·66
1166	0·14	16800	7420	2·00
611	0·58	16280	9040	2·56
613	1·00	14640	8680	6·43
614	1·25	14640	8840	6·43

The specimen marked B is the best commercial iron, but not quite as low carbon as the standard specimen S.C.I.; this latter not having been procured until after most of the magnetic determinations were made. The values obtained

\* In rods of high permeability, having this ratio of length to diameter (about 200 to 1), a correction is necessary for the values of the retentivity and permeability given in our tables and curves. Ewing has shown (*Phil. Trans.*, 1885, Part II.) that whilst the "on" curve—marked 1 in fig. 8—even in a soft-iron rod of 200 diameters is not much below the true value of that given by a much longer rod or ring; the "off" curve—marked 2 in fig. 8—is notably different as it approaches the point where it cuts the vertical axis at R, fig. 8. Here the demagnetising influence of the ends becomes apparent, and the result in soft-iron is to reduce the residual induction, or *retentivity*, about 40 per cent., compared with an endless rod or ring. We have not applied this correction, as the amount varies with the permeability of each specimen. A fair approximation to the true value can be found by inclining to the right, through a small angle, the vertical axis, OB, in the curves, Plates III. to IX. (See Note A at end of this Paper.)

† The absolute values of the maximum induction given in our Plates and Tables are a little too high, as explained in Note B, p. 126. The word "retentivity" must be understood to be the *residual induction* after our maximum field of 45 units has been reduced to zero.

for the specimen B are repeated in each table for convenience of comparison.\* It will be noticed from Table II. that the maximum induction for the highest field we employed (viz.  $\mathbf{H} = 45$ ) decreases as the percentage of carbon increases, and the coercive force increases in a similar manner. When the carbon reaches 1 per cent. the addition of  $\frac{1}{4}$  per cent., as in the specimens marked 613 and 614, has practically no effect on the maximum induction and coercive force, but as will be seen from the next table, the permeability for low magnetising forces is considerably higher in 613 than in 614. The fuller chemical analysis, of these and the other steels given in Part I., that was subsequently made, reveals the same fact, noticed in electrical conductivity, that small quantities of impurities seriously affect the magnetic property of these alloys.

We have mentioned two other magnetic properties of considerable practical importance which can be deduced from the  $\mathbf{B}$  and  $\mathbf{H}$  curves, viz. (1) the permeability ( $\mu = \mathbf{B}/\mathbf{H}$ ) of each specimen for any given value of  $\mathbf{H}$ , up to the highest magnetic field we employed; and (2) the hysteresis loss per complete cycle, *i.e.*, the energy dissipated in each alloy in passing through a complete magnetic cycle. The work,  $W$ , thus done in ergs per cubic centimetre can be found by measuring the area of the cycle curve.†

The next table gives the permeability for a magnetising force of 8 C.G.S. units, and the hysteresis loss of a few of the carbon steels; the maximum magnetising force of the cycle being in all cases 45 C.G.S. Here, and in all subsequent tables, the permeability is that given by the initial ascending curve shown by a thin line on the curves in the plates.

TABLE III.—Carbon Steels.

Mark.	Per cent. of carbon.	$\mu$ for $\mathbf{H} = 8$ .	Energy dissipated per complete cycle.
B	0.03	1560	11090
L.S.S.	0.05	1440	11463
611	0.58	950	22815
613	1.00	570	33730
614	1.25	375	34370

The work done in magnetising these steels, as might be expected, increases as the percentage of carbon increases, the permeability diminishing at the same time. We now pass to alloys of iron and manganese, of which the specimens marked (p) in Table IV. are given in Plate III.; another specimen of steel with 1 per cent. of manganese, 1420, is given in the annealed and unannealed states on Plate V.

\* The specimen B is called "Iron" in all the tables, except the carbon steels.

† For  $W = \frac{1}{4\pi} \int \mathbf{H} d\mathbf{B}$ , see "Ewing's Magnetic Induction in Iron and other Metals," chap. iv.

TABLE IV.—*Alloys of Iron and Manganese (Plate III.).*

Mark.	Per cent. of Mn.	Max. Induction, $H = 45.$	Retentivity.	Coercive force.
Iron (p)	0·03	17480	7120	1·66
48 (p)	0·5	16700	8730	3·2
4147 (p)	1·0	16200	9990	3·4
53 (p)	2·25	15400	9900	6·0
1379 B	3·5	12530	8950	17·8
1381*	3·8	3300	1550	20·0
39 (p)	4·0	9800	6080	16·2
34 (p)	4·75	8730	5590	19·6
945 A* (p)	7·0	4090	2320	20·0
1379 D	10·1	670	250	15·0
1310 B*	11·5	1200	590	13·0
1338 (p)	13·0	280	†	†
1379 D/2	15·2	0	†	†
30*	15·25	270	†	†
598*	18·5	225	†	†

From the above table it will be seen that a great drop takes place in the maximum induction, and a corresponding rise in the coercive force, when the quantity of manganese added to steel is somewhere between 3 and 4 per cent. The sudden rise in coercive force at this point is shown in fig. 12, p. 117. Upon referring to Plate III. the wide difference between the curves for specimens marked 53 and 39 is at once apparent. When the quantity of manganese in the alloy rises to between 7 and 10 per cent., further additions of manganese seem to have much less effect on the magnetic properties of the alloy; a 13 per cent. manganese steel, such as 1338, is practically non-magnetic. Upon referring to Plate II., showing the electric conductivity of manganese steels, the conductivity is likewise seen to decrease up to a 7 per cent. manganese steel, and then remains nearly constant up to the highest percentage tried.

Judging from the specimens here tested, a remarkable feature in the magnetic properties of the high manganese steels is the part played by the presence of carbon. Although the specimen marked 1310 B has 1 per cent. more manganese, it is considerably more magnetic than 1379 D. On turning to Group 2, p. 76,

\* These specimens all contain high carbon from 0·78 to 1·66 per cent. See Group 2, series B, p. 76.

† The curves in the last four specimens lay so close to the axis  $H$ , that the values of retentivity and coercive force were too small to be correctly measured.

it will be seen that 1310 B contains 1·5 per cent. more carbon than 1379 D. Again, 1379 D/2 has low carbon, and the specimen marked 30, with practically the same amount of manganese, has upwards of 1 per cent. more carbon; the former specimen is non-magnetic, but the latter is slightly magnetic, as also is 598, with 18·5 per cent. of manganese, and 1·54 per cent. of carbon. In the low manganese steels, carbon, as might be expected, decreases the magnetic induction, as will be seen by comparing specimen 4147 on Plate III., and 1420 on Plate V., both having 1 per cent. of manganese, but the latter having higher carbon. Even up to  $3\frac{1}{2}$  per cent. manganese steel the presence of carbon injuriously affects the magnetic condition as seen on comparing 1379 B and 1381 in the above table. The magnetic measurements of these specimens have been repeated with concordant results. The hardness of these specimens, as tested by the file, precisely agrees with their relative magnetic conditions: thus the specimen 1381 is considerably harder than 1379 B; and 1379 D harder than 1310 B; whilst 598 and 30 are softer than 1379 D/2. The condition in which the carbon exists in these steels is obviously very important; the chemical analyses given does not show this, and this point requires further elucidation.

The next table gives the permeability and hysteresis loss for those manganese steels given in Plate III.

TABLE V.—Alloys of Iron and Manganese (Plate III.).

Marks.	Percentage of Mn.	$\mu$ for $H = 8$ .	Energy dissipated per cycle.
Iron	0·0	1560	11090
48	0·5	1020	20460
4147	1·0	1000	23090
53	2·25	990	31860
39	4·0	130	41070
34	4·75	75	41000
945 A	7·0	27	20460
1338	13·0	0	980

The permeability of the last specimen was too small to be measured as will be seen from Plate III. The rapid fall of permeability between  $2\frac{1}{4}$  and 4 per cent. of manganese is remarkable; beyond this percentage the hysteresis loss diminishes, owing to the steel passing into a non-magnetic state. We will next take the alloys of iron and nickel.

TABLE VI.—*Nickel Steels* (Plate IV.).

Marks.	Percentage of Nickel.	Max. Induction for $H = 45$ .	Retentivity.	Coercive force.
Iron	0·0	17480	7120	1·66
1287 D	1·92	16750	8250	2·67
„ E	3·82	17000	8350	2·76
1267 B	4·75	11060	7300	14·28
1287 I	11·39	8560	4790	17·33
{ 1447 B	12·1	4330	2370	22·4
{ „ <i>unann.</i>	„	100	40	—
{ 1447 A	12·7	4630	2690	22·1
{ „ <i>unann.</i>	„	195	73	—
{ 1287 K	19·64	8100	4970	20·0
{ „ <i>unann.</i>	„	5940	3890	24·3
1287 L	24·5	4440	2820	22·5
{ 1449*	31·4	2890	1100	0·5
{ „ <i>unann.</i>	„	4680	1700	2·0

Two or three of the above specimens are not shown on Plate IV., which already is, we fear, somewhat overcrowded. The magnetic properties of the nickel steels form a very interesting study from several points of view. It will be noticed that the maximum induction for a field of 45 C.G.S. units is almost the same for the specimens 1287 D and E as for good iron, that is to say, up to nearly 4 per cent. of nickel the maximum induction in a field of 45 C.G.S. units appears to be scarcely affected, though, as will be seen from the next table, the permeability is somewhat less. The rather lower value of 1287 D in Table VI. is probably accidental, and may be due to a physical difference in this specimen. As the nickel increases from about 5 per cent. to about 18 per cent., the maximum induction and retentivity both decrease, and the coercive force increases; but with a still higher percentage of nickel, whilst the induction remains about the same, the coercive force suddenly falls: a remarkable softening of the steel, produced by the addition of over 20 per cent. of nickel, is seen in the specimen 1449. It will also be noticed, that as we pass from about 4 to 5 per cent. of nickel, a sudden increase in coercive force takes place, indicating an equally sudden rise in hardness. This is well seen in fig. 12, p. 117, which, however, does not show anything higher than 15 per cent. of nickel. This sudden change, first from softness to hardness, and then

\* The **B** and **H** curve for this specimen in the annealed state is given on Plate V., owing to the crowding of Plate IV.: the word 'unannealed' should have been added after '1449' in Plate IV.



the reversal back to softness by increasing the percentage of nickel, was most unexpected. Upon putting another set of specimens to mechanical tests for tensile strength and resistance to compression, similar changes in the mechanical properties were observed at nearly corresponding percentages. The following curves illustrate this remarkable behaviour. In fig. 9 the coercive force in C. G. S. units of these nickel-steels is plotted, the abscissæ being percentages of nickel, and the ordinates coercive force  $\times 2$ . This curve shows the relative magnetic hardness of these alloys; the relative magnetic softness is shown by the reciprocals of the coercive force, which are also plotted on the same figure. In fig. 10 the tensile strength in tons per sq. inch is shown, the abscissæ being as in fig. 9, and

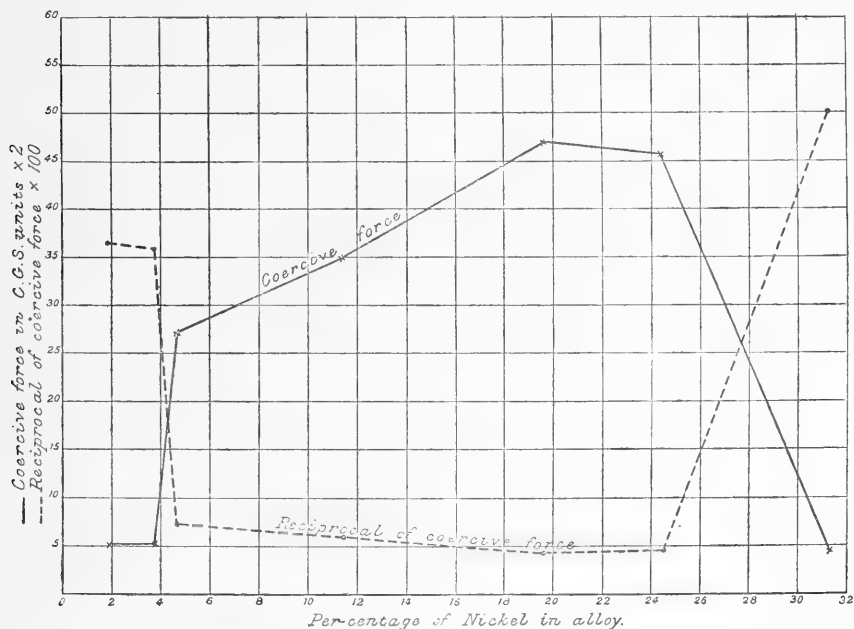

FIG. 9.

the ordinates the breaking stress in tons per sq. inch. Again in fig. 11 the reduction in length per cent. produced by a compression load of 100 tons per sq. inch is shown, the ordinates in this case being the percentage reduction.\*

This latter curve illustrates the mechanical softness of these alloys, and will be seen to be very similar to that of the magnetic softness on fig. 9, whereas the curve on fig. 10, showing the tenacity, resembles the magnetic hardness shown on fig. 9.

\* See paper on *Nickel Steels*, by R. A. Hadfield, *Proc. Institute of Civil Engineers*, March, 1899.

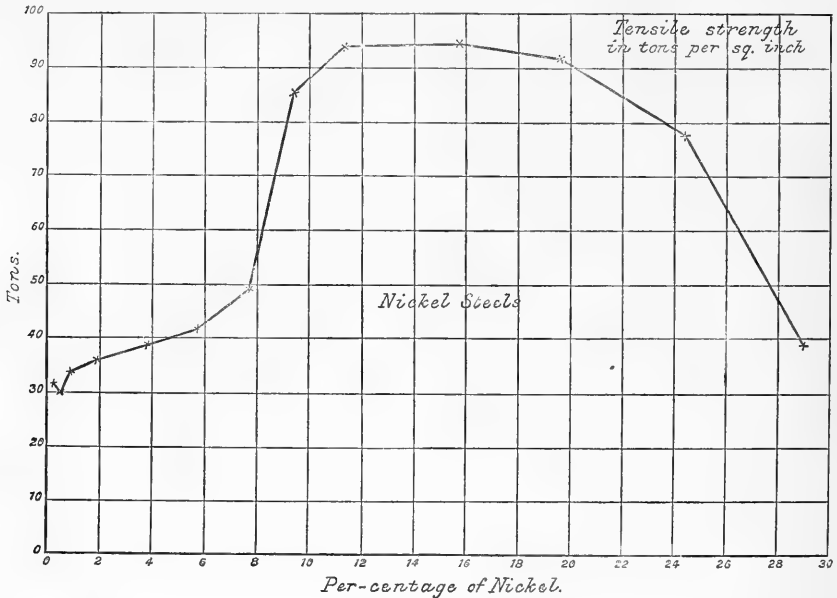

FIG. 10.

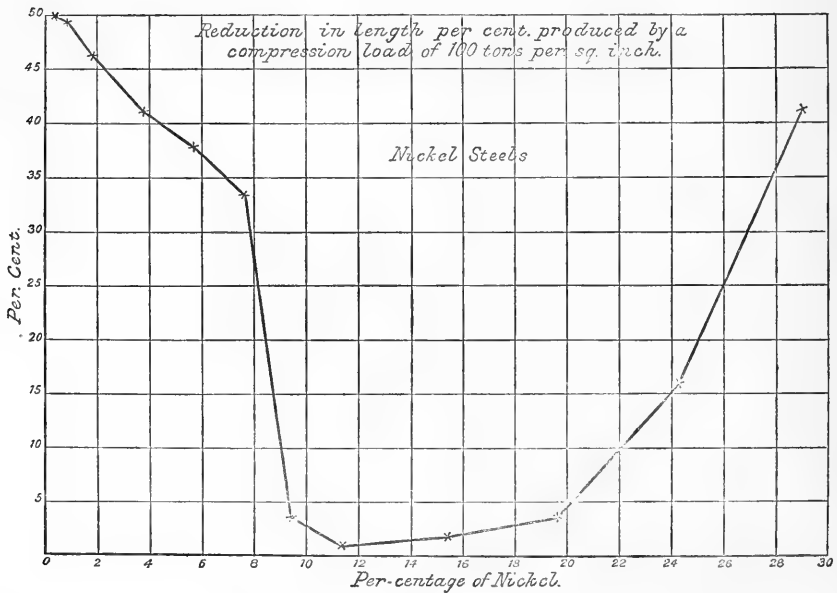

FIG. 11

There is, however, this difference; the first flexure in the magnetic properties of the curve appears to take place at about 4 per cent., whereas the first flexure in the mechanical properties takes place a little under 8 per cent.; the second flexure occurs at about 24 and 20 per cent. respectively. This is better seen by referring to the hysteresis loss in Table VII. These slight differences, probably due to differences in heat treatment, will doubtless be cleared up by further experiments, when a more complete set of these nickel steels has been prepared for the determination of their magnetic properties.

The effect on the magnetic and mechanical properties produced by the prior heat treatment, to which these steels have been subjected, is most marked, especially in certain percentages of nickel.\* This is well seen from Table VI. The specimens containing 12·7 and 12·1 per cent. of nickel were only slightly magnetic in the unannealed condition, in a field of 45, whereas they were fairly magnetic when annealed. In much stronger fields, however, their magnetisation in *both* physical states rises considerably, and soon much exceeds that of the higher nickel steels, which are saturated in lower fields. The permeability and the hysteresis loss of several of the nickel steels is shown on the next Table.

TABLE VII.—*Nickel Steels.*

Marks.	Percentage of Nickel.	$\mu$ for $H = 8$	Energy dissipated per cycle.
Iron	0·0	1560	11090
1287 D	1·92	1290	15760
„ E	3·82	1280	16340
1267 B	4·75	140	41000
1287 I	11·39	120	33000
{ 1447 B	12·1	115	22500
{ „ <i>unann.</i>	„	0	—
{ 1447 A	12·7	60	25000
{ „ <i>unann.</i>	„	0	900
{ 1287 K	19·64	96	38000
{ „ <i>unann.</i>	„	60	36130
1287 L	24·5	50	22850
{ 1449	31·4	365	930
{ „ <i>unann.</i>	„	300	2420

\* This subject, as is well known, was first investigated by the late Dr. Hopkinson, who discovered that steels containing from  $4\frac{1}{2}$  per cent. of nickel and upwards could exist in a stable magnetisable or non-magnetisable state, according to the prior temperature to which they had been subjected. Dr. Hopkinson also found that nickel steels, up to  $4\frac{1}{2}$  per cent., were capable of higher magnetisation than wrought iron, in fields of from 30 to 50 C. G. S. units: see *Proc. Royal Society* for 1889 and 1890.

Up to nearly 4 per cent. of nickel the hysteresis loss increases but slightly, being less than that occurring with a corresponding addition to iron of any other element, so far tried, except aluminium and silicon. As before stated, an increase in magnetic hardness occurs at about 4 per cent. of nickel, and hence the hysteresis loss is seen to rise suddenly in the specimen 1267 B. The reverse effect produced by still larger additions of nickel is also well seen, the change taking place at about 20 per cent. of nickel. The increase of permeability in the last specimen is remarkable, a rod of this alloy being practically saturated in a field of about 16 C.G.S. units. Notice also the opposite effects produced by annealing in the different percentages of nickel.

The great permeability of the low and very high nickel steels is remarkable, and ought to be determined for still lower magnetising forces. It was noticed that under the feeble force of the Earth's magnetic field the high nickel steel, 1449 (annealed), had a higher permeability than a specimen of the very best iron. In a future series of experiments the magnetic properties of these and the silicon and aluminium steels under small magnetic forces, and at different temperatures, will be investigated.

The effect of annealing on the magnetic properties of alloys is further seen in a striking manner in Plate V., which contains the **B** and **H** curves of a nickel chromium, and a manganese chromium steel, compared with good iron and a low manganese steel.

TABLE VIII.—*Effect of Annealing* (Plate V.).

Marks.	Percentage.			Max. Induction, <b>H</b> = 45.	Retentivity.	Coercive force.
	Ni.	Mn.	Cr.			
Iron	—	—	—	17480	7120	1·66
{ 1420	—	1·00	—	15000	8800	7·74
{ „ <i>unann.</i>	—	„	—	14000	10180	15·74
{ 1430 A*	—	3·09	8·92	13280	11100	11·36
{ „ <i>unann.</i>	—	„	„	470	†	†
{ 1450 A	12·24	0·54	2·01	3720	1710	22·05
{ „ <i>unann.</i>	„	„	„	200	†	†

It will be seen that whilst the annealed specimens of 1430 A and 1450 A are magnetic, the former strongly so, the unannealed specimens are only slightly magnetic in a field of 45 C.G.S. units. In the steel 1420, with 0·5 per cent. of carbon, the coercive force is doubled in the unannealed specimen, that is to say, the hardness in the two states differs widely.

\* This specimen also contains 1·3 per cent. of carbon.

† These values were too small to be estimated, the specimens being almost non-magnetic, in the field.

TABLE IX.—(Plate V.)

Marks.	$\mu$ for $\mathbf{H} = 8$ .	Energy dissipated per cycle.
Iron	1560	11090
{ 1420	340	36700
{ „ unann.	210	57300
{ 1430 A	155	47060
{ „ unann.	0	480
{ 1450 A	37	19950
{ „ unann.	0	550

The specimen, 1430 A, has nearly 9 per cent. of chromium added to a steel containing 3 per cent. manganese, and also very high carbon. Upon referring to Tables IV. and V., it will be seen that a corresponding steel without the chromium has higher coercive force but lower retentivity, and on comparing the respective areas of the curves given in Plates III. and V., the larger hysteresis loss in the manganese chromium steel is apparent. This comparison is of the *annealed* specimens; the effect of annealing is seen to be much greater on the chromium-manganese steel, which is but feebly magnetic in the unannealed state in this field. The large hysteresis loss, shown by 1420 in the *unannealed* condition, is due to its high coercive force combined with great induction and retentivity; the large area of this curve is seen on Plate V. On referring to Group 2, p. 76, it will be noticed that this steel has 0.75 of carbon and 1 per cent. of manganese, whereas 4147 has the same percentage of manganese and only 0.24 carbon. This small difference in the carbon will be seen to make a great difference in the hysteresis loss of the annealed specimens in the two cases (see Tables V., p. 109, and IX. above); in the unannealed state probably a still greater difference would be found; the specimen 4147, however, was not tested before being annealed.

The next Table gives the magnetic properties of all the tungsten steels we have examined.

TABLE X.—Tungsten Steels. (Plate VI.)

Marks.	Per cent. of tungsten.	Maximum induction, $\mathbf{H} = 45$ .	Retentivity.	Coercive force.	$\mu$ for $\mathbf{H} = 8$ .	Energy dissipated per cycle.
Iron	0.0	17480	7120	1.66	1560	11090
1294 F	1.0	16600	8320	3.23	1360	14590
„ H	3.5	16400	12500	5.73	1180	25830
„ I	7.5	15920	13580	9.02	410	49000
„ L	15.5	11560	9620	13.92	117	45320

The most interesting fact in the above results is the small decrease in induction, together with the great increase of retentivity and coercive force up to a  $7\frac{1}{2}$  tungsten steel; the retentivity being higher in this last steel, 1294 I, than in any alloy we have examined. Tungsten steel has long been used for making permanent magnets, but the percentage of tungsten added to the steel is important. The highest magnetic power attainable with the greatest retentivity evidently lies between a 4 and 7 per cent. tungsten steel.

The large hysteresis loss in 1294 I is due to the great increase in retentivity and coercive force combined with the high induction in this specimen. The steady rise in coercive force with increase of tungsten is well seen in fig. 12, p. 117.

It must be remembered that all our specimens (except a few duplicates marked unannealed) had been most carefully annealed (see p. 68) before being tested magnetically. Hence the coercive force and the hysteresis loss are very much less than would be found in unannealed or hardened specimens.

The next series is a small group of aluminium steels.

TABLE XI.—*Aluminium Steels.* (Plate VII.)\*

Marks.	Per cent. of Al.	Maximum induction, $H = 45$ .	Retentivity.	Coercive force.	$\mu$ for $H = 8$ .	Energy dissipated per cycle.
Iron	0	17480	7120	1.66	1560	11090
1167 D	0.75	16500	8000	2.00	1517	11620
„ H	2.25	16500	7620	1.87	1620	10960
1167 I	5.50	13410	3480	1.43	1095	6825

The remarkable fact is revealed that the addition of aluminium to steel but slightly affects its magnetic induction and coercive force up to  $2\frac{1}{4}$  per cent. A larger percentage softens the steel and the retentivity and coercive force both fall. This reduction of coercive force is seen in fig. 12. The hysteresis loss, which is increased by the addition of most other elements to iron, is slightly decreased in a  $2\frac{1}{4}$  per cent. aluminium steel, and considerably decreased in the  $5\frac{1}{2}$  per cent. specimen, notwithstanding the maximum induction, in a field of 45 C.G.S. units, still remains very high.

The permeability of the  $2\frac{1}{4}$  per cent. aluminium steel, at a magnetizing force of 8 C.G.S. units, is even higher than good iron: the fuller chemical analysis of these steels is given in group 5, p. 83.

\*The curve, 1178 D, belongs to Table XII., aluminium-chromium steels.

The effect on magnetic hardness produced by different percentages of various metals added to iron is shown in fig. 12, where the ordinates represent coercive force and the abscissæ percentages of the added element. The steady rise in the case of the tungsten steels is noticeable. The wonderful softness produced by the addition of silicon to steel is not shown in fig. 12, but will be referred to presently.

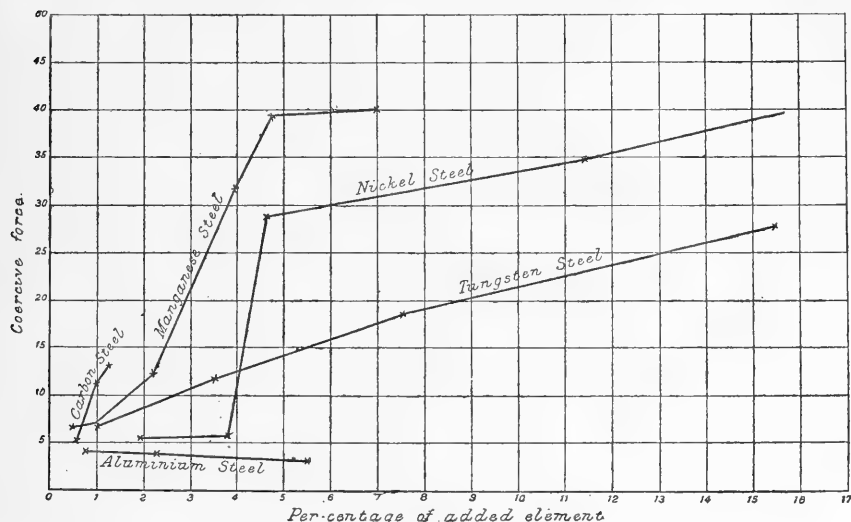

FIG. 12.

The addition of chromium to aluminium steel has the effect of hardening it, and, therefore, injuring the valuable magnetic properties of a pure aluminium steel. Aluminium and chromium have, therefore, opposite effects on steel magnetically.

TABLE XII.—Chromium Aluminium Steels (Plate VIII.).

Marks.	Percentage.		Max. induction.	Retentivity.	Coercive force.	$\mu$ for $H = 8$ .	Energy dissipated per cycle.
	Cr	Al					
Iron	—	—	17480	7120	1.66	1560	11090
1178 D	1.5	2.25	14460	8990	3.52	1130	18090
„ E	1.5	4.50	13705	6860	1.77	1042	13830
„ B	1.75	0.75	15070	9690	6.00	964	26550
1179 B	3.50	1.00	14400	9500	8.00	363	35780

It is instructive to note the difference in this respect between the specimens 1178 E and 1179 B. When the amounts of chromium and aluminium are nearly reversed, the hardness of the latter specimen is seen in its high coercive force and low permeability. By comparing 1167 D, Table XI., with 1178 B, Table XII., we see that the addition of 1.75 per cent. of chromium to a low aluminium steel more than doubles the hysteresis loss, whilst the coercive force is increased three times. The large amount of aluminium in 1178 E lowers the coercive force, and hence much reduces the hysteresis loss of this specimen.

The addition of small percentages of copper does not seem to have much effect on the magnetic properties of steel as is seen by comparing 1264 A and B in the next Table, which are similar steels, except that 1264 B has about 1 per cent. more copper.

TABLE XIII.—*Copper Steels.*

Marks.	Per cent. of copper.	Max. induction, H = 45.	Retentivity.	Coercive force.
Iron	0.0	17480	7120	1.66
1264 A	1.59	15010	10840	5.0
„ B	2.5	14860	10740	5.4
*1263 C	2.87	15160	9810	5.3

The large coercive force of these copper steels may be due to the high carbon or manganese they contain, as will be seen by referring to the full analysis given in Group 8. Another steel containing  $14\frac{1}{2}$  per cent. of copper with manganese and chromium is given in Table XV. The B and H curves of these copper steels have not been engraved, and it also seemed hardly worth while to determine their hysteresis loss.

Passing on to the effect produced by *Chromium* on the magnetic properties of iron, we have examined two specimens of chromium steel, besides several other chromium steels, containing nickel or tungsten in addition to chromium. The percentage composition of these and other steels is given in the next table. A nickel chromium steel, 1450, has already been given in Table VIII., p. 114; comparing this with 1447 A and B (see p. 110), which have the same quantity of nickel but no chromium, we find all three barely magnetic in a field of 45, in the *unannealed* state, but magnetic in a field of 300, the induction of 1447 being twice that of 1450, showing the effect of chromium.

\* This specimen has also 1 per cent. of manganese.



TABLE XIV.—Chromium, Nickel-Chromium, and other Steels.

Marks.	Percentage.				
	Cr	Ni	W	Mn	C
1177 I	3.25	—	—	—	0.43
„ N	9.50	—	—	—	1.09
1286 A	0.75	2.75	—	—	0.25
„ C	1.75	2.50	—	—	0.31
1210 D	4.50	2.50	—	—	0.41
1189 B	0.75	—	2.00	—	0.25
687	—	—	3.25	2.25	0.40
1254 C	—	4.00	—	3.75	0.57

TABLE XIV.—(continued).

Marks.	Max. Induction, $H = 45$ .	Retentivity.	$\mu$ for $H = 8$ .	Coercive force.
Iron	17480	7120	1560	1.66
1177 I	12280	8480	150	12.25
„ N	12600	10560	460	8.25
1286 A	16990	7980	1250	3.00
„ C	15610	11450	500	7.9
1210 D	14060	10100	—	13.1
1189 B	16470	12510	1160	5.3
687	15820	12430	840	6.5
1254 C	6610	3890	125	19.6

It will be observed that a  $3\frac{1}{4}$  per cent. chromium steel has a high coercive force and low permeability, but when the chromium is increased to  $9\frac{1}{2}$  per cent. the coercive force is diminished and the permeability increased, whilst the max. induction remains practically the same. Whether this anomalous behaviour be due to the higher carbon in the latter specimen, or some accidental difference in annealing, we cannot say. Adding nickel to a low chromium steel improves it magnetically, the max. induction is increased, and the permeability very largely so, as in specimen 1286 A, which has under 1 per cent. of chromium. As the quantity of chromium increases in the next two specimens, the nickel remaining

nearly constant, the steel becomes much harder magnetically, the permeability falls rapidly, and the coercive force and hysteresis loss each rise to a high figure.

The above table also affords an interesting comparison of the magnetic effect produced on a chromium steel by adding tungsten instead of nickel. In 1286 A we have a nickel-chromium, and in 1189 B a tungsten-chromium steel of nearly the same relative composition. The last two specimens in Table XIV. show the effect of adding tungsten and then nickel to a *manganese* steel. The nickel-manganese steel is much worse magnetically than the tungsten-manganese steel. This difference is, however, probably due to the fact that the quantity of manganese is  $1\frac{1}{2}$  per cent. larger in the former alloy. We have already found that when the quantity of manganese added to steel lies between 3 and 4 per cent., a great change for the worse is produced in the magnetic properties of the alloy, as will be seen by referring to Table IV. and Plate III.

It is not therefore surprising that high nickel-manganese steels have an enormous electrical as well as magnetic resistance. Out of the group of nickel-manganese steels given in Group 12, p. 89, the following are practically non-magnetic in a field of 45, and, even when annealed, are only feebly magnetic in a field of 300 C. G. S. units. Beginning with the least magnetic, we have 1109 D, 1414 A, 1414 B, 1339, 1313 C, also the two manganese-tungsten steels, 1343 B and 1343 A, given on p. 92, and the copper-manganese-chromium steel, 1424 B, given on p. 97. In addition to the foregoing feebly magnetic steels, those manganese steels containing 13 per cent. of manganese and upwards are also nearly non-magnetic. (See Table IV., p. 108.)

We do not propose, in the present paper, to enter upon a discussion of the interesting facts revealed by the above results, or the relative effect of different elements, when alloyed with iron, in reducing or destroying its magnetic susceptibility. We hope to return to this question in another paper. One element, aluminium, may actually increase the susceptibility of iron in comparatively low magnetic fields, and another, silicon, has the same effect still more conspicuously, as will be seen below.

---

ADDED NOVEMBER, 1899.

The group of steels contained in the next Table shows the most remarkable result we have yet obtained, the effect produced on the magnetic properties of iron by the addition of *silicon*. Ordinary steel usually contains a small quantity of silicon, and it was noticed early in this investigation that the increase of silicon did not magnetically injure, but rather improve, a carbon steel; its magnetic effect appeared to resemble that produced by aluminium.

Unfortunately, most of the specimens contained in Table XVI. were examined too late to have their **B** and **H** curves inserted on Plate IX., which contains only the first two specimens, 1397 A and B; these also show that a small percentage of silicon improves, magnetically, a low nickel steel. As the carbon is low in all these specimens (except 803), they may more properly be called silicon-iron alloys than silicon steels.

TABLE XVI.—*Silicon-Iron Alloys.*

Mark	Percentage.		
	Si	Ni	C
1397 A*	0·44	—	0·22
„ B*	0·33	0·58	0·26
898 E	2·5	—	0·20
„ H	5·5	—	0·26
803†	2·25	—	0·67
1103 A	2·0	3·25	0·38
„ C	3·25	3·50	0·22

TABLE XVI.—*Silicon-Iron Alloys (continued).*

Marks.	Max. Induction, <b>H</b> = 45.	Retentivity.	$\mu$ for <b>H</b> = 8.	Coercive force.
Iron	17480	7120	1560	1·66
1397 A	15720	10800	640	7·46
„ B	16940	12040	920	7·33
898 E	16640	4080	1680	0·90
„ H	16480	3540	1680	0·85
803	16000	8320	1345	3·70
1103 A	16240	6990	1120	2·00
„ C	15960	7270	1280	1·90

The interesting fact is revealed by the above Table that the addition of 2 to  $5\frac{1}{2}$  per cent. of silicon to steel, as in the specimens 898 E and H, increases the magnetic softness to such an extent that the coercive force and retentivity are reduced to nearly one-half that of the standard iron rod, which contains only 0·03 per cent. of carbon. The permeability of these specimens is also higher than iron for magnetising forces below saturation, whilst the max. induction

\* These two specimens contain 0·18 per cent. of manganese.

† This specimen also contained 0·5 per cent. of aluminium and high carbon: it is therefore a silicon aluminium steel.

is not very much lower than iron.\* As 2 or 3 per cent. of added nickel also improves steel magnetically, it was interesting to see what magnetic effect would be produced in steel by the addition of both silicon and nickel in these percentages. This is shown in specimens 1103 A and C, which, however, are not as good as the silicon steels alone.

Owing to the very high permeability of the silicon steels, it was desirable to compare one of them more fully with the purest specimen of commercial iron obtainable, containing only 0.028 per cent. of carbon (marked S. C. I.), which specimen, moreover, had been carefully annealed.† For this purpose the specimen 898 H, with 5.5 per cent. of silicon was selected, and the permeability determined with magnetising forces varying from 2 to 40 C. G. S. units: the results are given in the next Table.

TABLE XVII.—*Permeability of Silicon Iron compared with best Wrought Iron.*

Magnetising field in C. G. S. units.	S. C. I.	898 H.
2	1840	2240
4	2050	2630
8	1610	1680
12	1200	1160
16	965	910
20	800	745
30	560	515
40	435	400

It will be noticed that for magnetic fields up to 8 C. G. S. units the permeability of 898 H is higher than nearly pure iron. For weaker fields than the above the permeability of 898 H, as might be expected, compared still more favourably with the best iron. The vertical force of the Earth's magnetic field (0.45 C. G. S. units at the place of observation) produced in 898 H a magnetic induction of 1240, and in S. C. I. an induction of 600. For this weak field the permeability of the silicon steel is therefore rather more than double that of the best iron.

\* Since the foregoing results were obtained we notice that Mr. F. C. Caldwell has recently found that silicon increases the permeability of *cast-iron*, when present in amounts varying from 1.8 to 4.6 per cent., for inductions up to 8000 C. G. S. It does not appear, however, that Mr. Caldwell obtained a permeability higher than that given for Bessemer iron, owing to the nature of the material he employed.—(See *Science Abstracts*, May, 1899, p. 300, taken from a paper in the *Electrical World*, an American journal.)

† The full analysis of this specimen is given in Part I, p. 73.

A correction is of course necessary for the demagnetising effect of the ends in all these highly permeable specimens; see Note A at end. Experiments are in progress with more slender and carefully turned rods and rings of silicon iron, and the best iron (S. C. I.), in order to compare more accurately their magnetic properties; as far as they have gone, these confirm the general results above stated. The comparatively small susceptibility of iron to feeble magnetic forces has been long known, but we believe that hitherto no other substance has been found better than iron in this respect.

The coercive force of the silicon steel is about one half that of the best iron, S. C. I., its retentivity is also much less, and the hysteresis loss per complete magnetic cycle is therefore much smaller. The **B** and **H** curves of S. C. I., and the 5½ per cent. silicon steel, were carefully plotted, their areas measured, and the ergs dissipated per complete cycle, with a maximum magnetising force of 45 C. G. S. units, were found, with the following results:—

TABLE XVIII.

Marks.	Percentage.		Energy dissipated per complete cycle.
	C	Si	
Iron (B)	0.03	—	11090 ergs.
„ (S. C. I.)	0.028	—	10100 „
Silicon Steel (898 H)	0.26	5.5	6500 „

It is hardly necessary to point out the great importance of the above results from a theoretical as well as practical point of view. We may add that these silicon-iron alloys, as well as some of the manganese steels, manganese-nickel steels, and tungsten steels are patented products.

Some low silicon steels were tested by Mme. Sklodowska Curie in her investigation on the magnetic properties of tempered steels. Mme. Curie states that “the presence of small quantities of silicon does not appear sensibly to alter the magnetic properties of steel.”\* But in the table of results, given by this able experimenter, it will be seen that a tempered steel, containing 1.28 per cent. of silicon, has its coercive force reduced about 32 per cent. when compared with steel containing the same percentage of carbon, but without silicon.

The specimens employed by Mme. Curie were those used by M. le Chatelier, to which we have referred on p. 99, and consisted of short bars, whose length was only twenty times their diameter; the magnetic reaction of the ends was

\* See *Bulletin de la Société d'encouragement pour l'industrie nationale*, Janvier 1898, p. 53.

therefore in some cases considerable, and the correction which it was necessary to apply was uncertain in amount. The coercive force found in Mdme. Curie's experiments seems abnormally large, but the specimens used were highly tempered, and for the most part contained high carbon; hence a comparison is not possible between these results and our own, except perhaps in a few carbon steels, which were in similar physical states. In these, Mdme. Curie finds the coercive force increases regularly as the amount of carbon present increases, up to 1·2 per cent.; whilst the residual induction, or retentivity, reaches a maximum at 0·5 per cent. of carbon, and then decreases. Both these results we have also found, as will be seen in the table given on p. 106. We may add that our experiments were made, though not published, some years prior to the appearance of Mdme. Curie's paper.

A careful determination of the magnetic properties of a few carbon steels and alloys of steel with manganese, chromium, and tungsten was made by Dr. J. Hopkinson, the result being given in his classical paper already referred to, p. 99.\* Dr. Hopkinson employed the "yoke" method, and used much higher magnetising forces than we have done; his specimens were few, and as a rule contained high carbon, as well as being in different physical states. Where his specimens and ours are comparable, the results—though obtained by wholly different methods of experiment—are not far apart, his maximum induction is of course higher, owing to his magnetising force being 200, whilst ours was 45 C. G. S. units, and in some similar specimens he finds a higher coercive force than we do.

It is interesting to compare the results obtained by Dr. Hopkinson, Professor J. A. Ewing, and ourselves with a specimen of good annealed iron. Hopkinson used the "yoke" method, with short, turned, cylindrical bars; Ewing† used a wire, the length of which was 400 diameters, and employed the ballistic method of measurement; we used nearly cylindrical rods, with a length of 200 diameters, and the magnetometric method. Here are the results for magnetising forces of 200, 17, and 45 C. G. S. respectively:—

	Hopkinson. $H = 200.$	Ewing. $H = 17\cdot3.$	Our results (uncorrected).
Maximum induction, . . .	19540	13450	17480
Residual induction, . . .	7080	10980	7120
Permeability $H = 8,$ . . .	1400	1550	1560
Coercive force, . . . . .	1·63	1·90	1·66
Energy dissipated, in ergs, .	10290	9300	11090

The specimen of iron we used was of higher purity than the sample used by

\* *Phil. Trans. of the Royal Society*, 1885, Part II., p. 455.

† *Ib.*, p. 523.

Hopkinson, and probably than that used by Ewing. In a specimen of *very pure* iron from the Elswick works, the maximum induction in the same field as ours, 45 C.G.S., is given as 17450 by Messrs. Lydall and Pocklington in the *Proceedings of the Royal Society*, vol. 52, p. 228. From tests made on a sample of Hadfield's dynamo "steel," Prof. Ewing gives the maximum induction at 45 as 16900, more complete tests at Finsbury College, with a ring of the same steel, gave the following values:—

Maximum induction,	. . .	16480,	for H = 45·5.
Permeability,	. . .	1600,	„ „ = 8·0.
Coercive force,	. . .	1·75	„ „ = 65·0.
Loss in ergs per cycle,	. . .	12080,	„ „ = 65·0.

The correction for the demagnetizing action of the ends raises the residual induction and permeability in our specimen of iron, as will be seen in Note A here appended.

In conclusion, we desire again to express our thanks to Mr. Allen and Mr. Wills for frequent assistance in the numerous observations required in the second part of this paper.

---

#### NOTE A.

As we have already pointed out, a correction is necessary for the demagnetizing reaction of the ends in our rods, especially in those of high permeability. Prof. J. A. Ewing, F.R.S., has shown (*Phil. Trans.*, 1885, Part II., p. 536) that "even when dealing with the softest iron, we may take a rod, whose length is not less than 300 diameters, as giving results scarcely different from those given by a ring or longer rod": and, "in hard iron and in steel a smaller ratio of length to diameter would, no doubt, give an equally good approximation to the condition of endlessness." In his work on *Magnetic Induction in Iron and other Metals*, p. 31, Ewing gives a table of correcting factors for rods of various lengths. The rods we have tested are 200 diameters long, and, according to Ewing, the actual magnetizing force is the original force in the solenoid, diminished by 0·000125 times the induction for any given point. Thus, if we take a point on the **B**—**H** curve of our annealed iron (this curve is repeated in each plate), where **B** = 16000, we find **H** = 16·5; then the actual value of **H** for this induction will be 16·5 - 2 = 14·5, since 0·000125 × 16000 = 2; and so on for any other point on the curve. It therefore follows that the values of **H** must not be measured from the vertical axis **OB**, but from a line inclined to the right, and drawn through **O** to a point whose co-ordinates are **B** = 16000 and **H** = 2: this line will make an angle of two degrees with **OB**. It is easy to draw such a line on our plates, by placing a straight-edge

at O and at the middle of the first division to the right of OB at the point 16000. It will be seen that, practically speaking, this correction only affects the values of the residual induction and permeability shown on our plates and tables, and mainly of those specimens having a high permeability. Thus the residual induction of iron will be raised in round numbers from 7000 to 10,000, or about 40 per cent., whilst that of a specimen of lower permeability, like 1267 B on Plate IV., will be raised only  $2\frac{1}{2}$  per cent. The values given in our tables are deduced from the experimental results, without any corrections being applied; for the correcting factor really relates to long ellipsoids, and it is only as a first approximation that it can be applied to cylindrical rods such as ours.\*

As already stated on p. 100 we have had some of our specimens made in the form of rings; these were turned out of a solid block of the material in as nearly as possible the same physical state as our annealed rods. The experiments on these rings are still in progress, and when completed we shall be able to obtain a more accurate knowledge of the demagnetizing factor for specimens having a wide range of permeability.

It is perhaps desirable to repeat that we have used the word "retentivity" in our tables as a brief expression for the residual induction after a maximum magnetising force of 45, but the true definition of retentivity is that given by Du Bois in his recent work on the Magnetic Circuit, viz. the *ratio* of the residual to the maximum induction.

---

#### NOTE B.

Owing to difficulties in exact magnetometric measurements in an unsuitable laboratory, we have found, since this paper was in type, that the values assigned to the induction **B** in our Plates and Tables must be reduced about 2 per cent., but this only affects the absolute values, and not the comparative results.

A recent repetition of the magnetic cycle with our best annealed iron rod S.C.I. turned down till its length was 255 diameters, together with a redetermination of the Earth's horizontal force in a better place of experiment, gave a maximum induction (for 45 C.G.S. units) of 16750. This is about four per cent. lower than we have given in our tables for our standard iron rod marked B, but this latter, though less permeable in low fields than S.C.I., has a higher induction at 45, probably due to its slight difference in chemical composition or annealing.

\* It appears from some recent experiments by Mr. C. G. Lamb, M.A., "On the distribution of magnetic induction in a long iron bar," that the employment of a constant demagnetizing factor is not quite correct. Mr. Lamb concludes that "the magnetometric method with long cylindrical rods, although extremely useful for comparative work, must be used with much caution in determinations of an absolute character."  
—*Proceedings of the Physical Society*, December, 1899, p. 517.



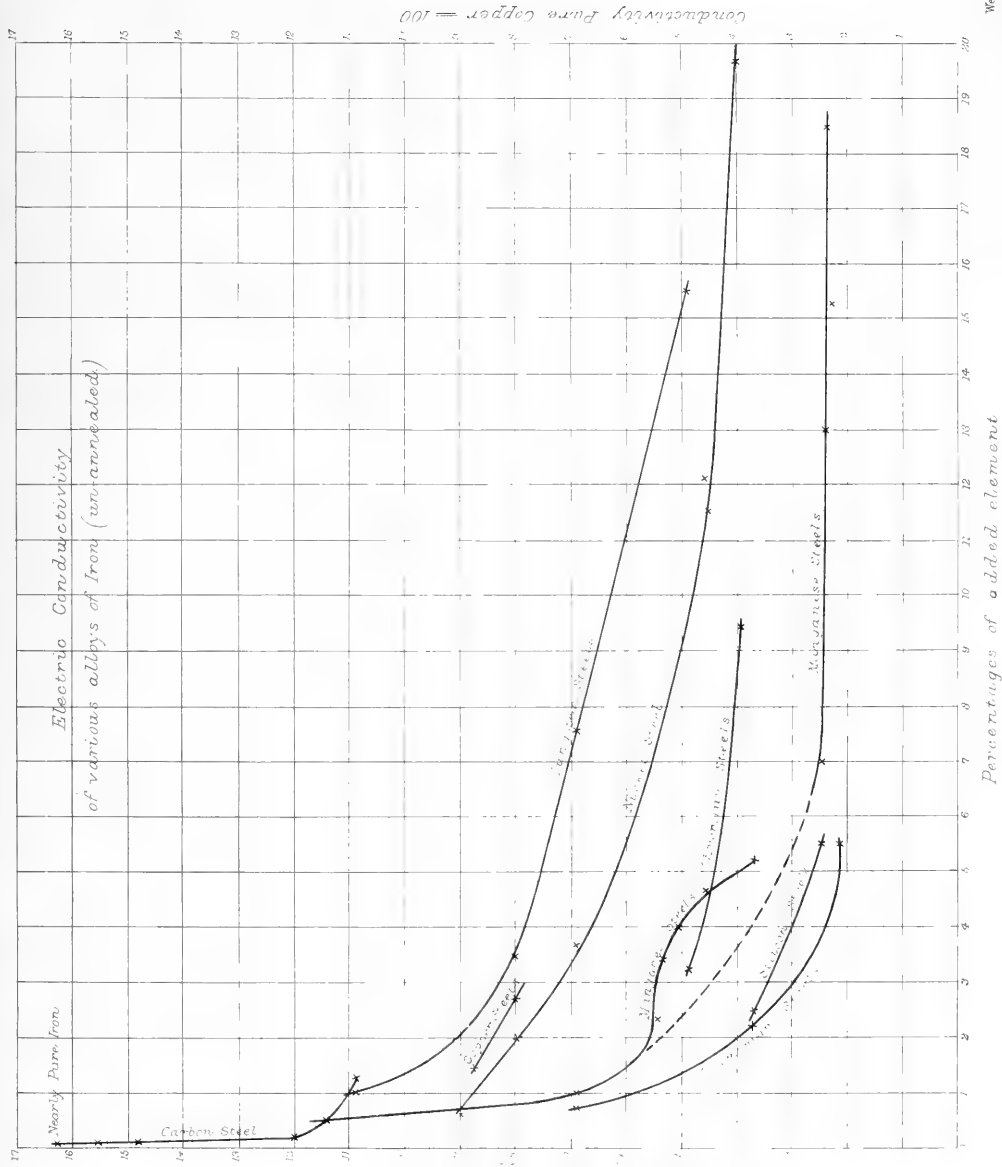



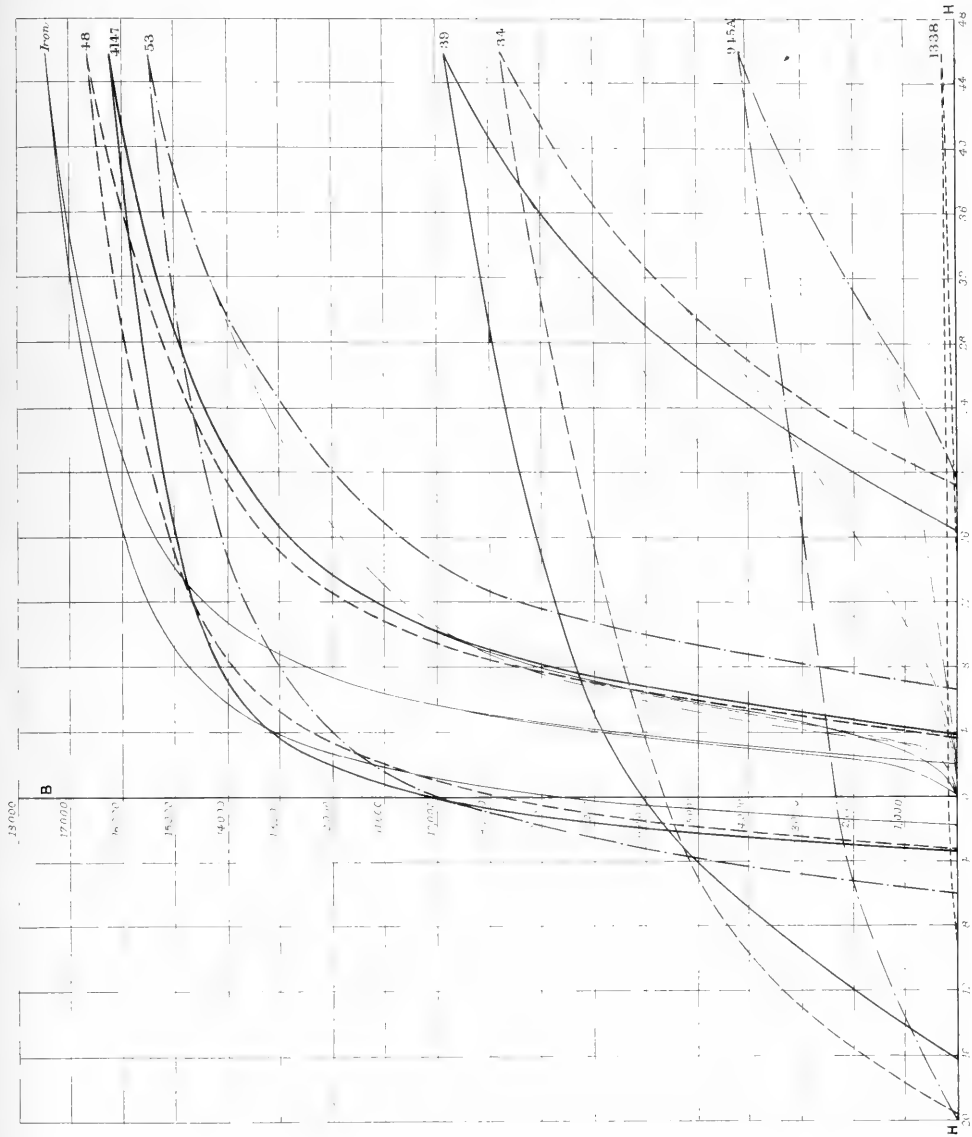

Temp. Steels, etc.

MANGANESE STEELS



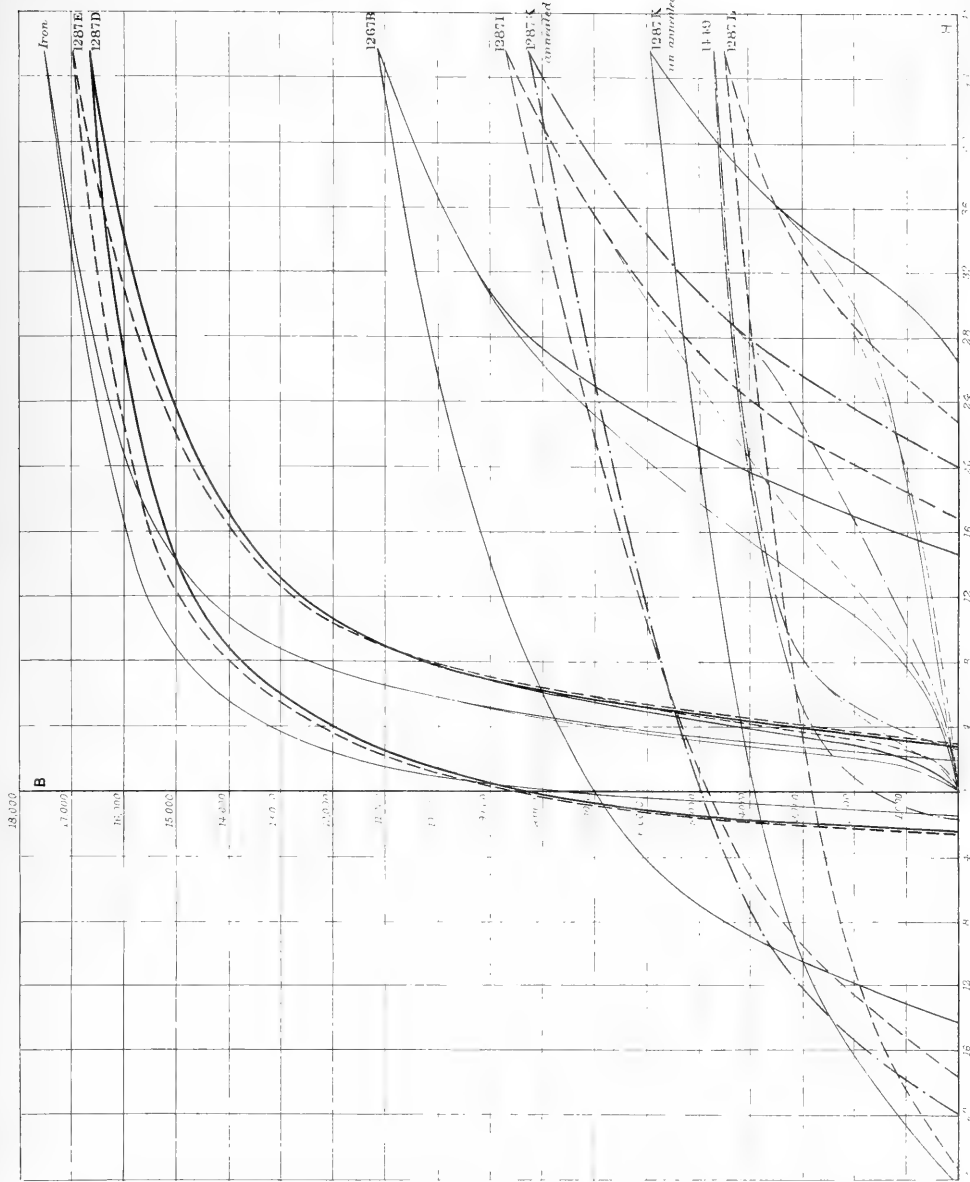



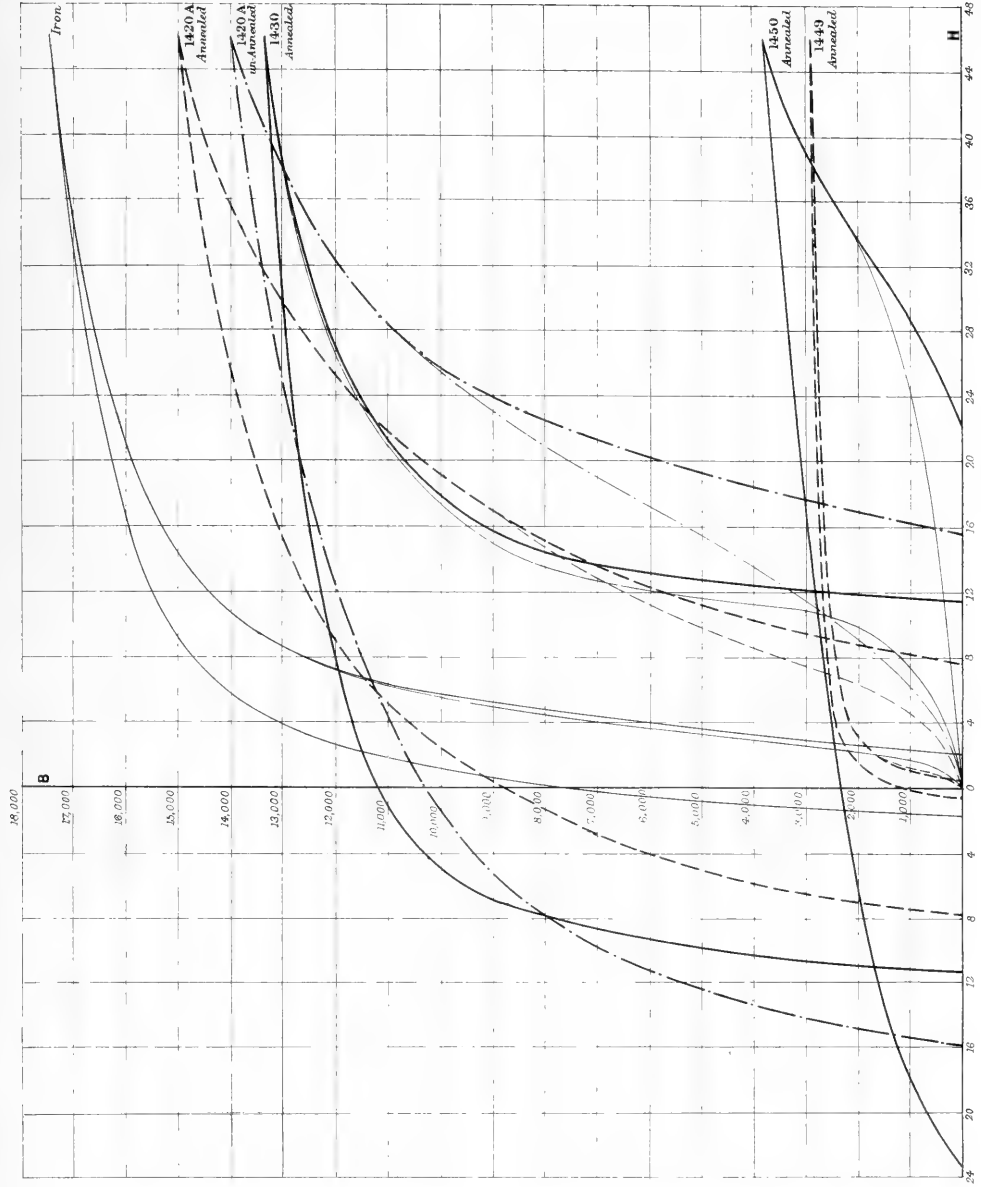

NI. AND CR. STEELS. (effect of annealing)





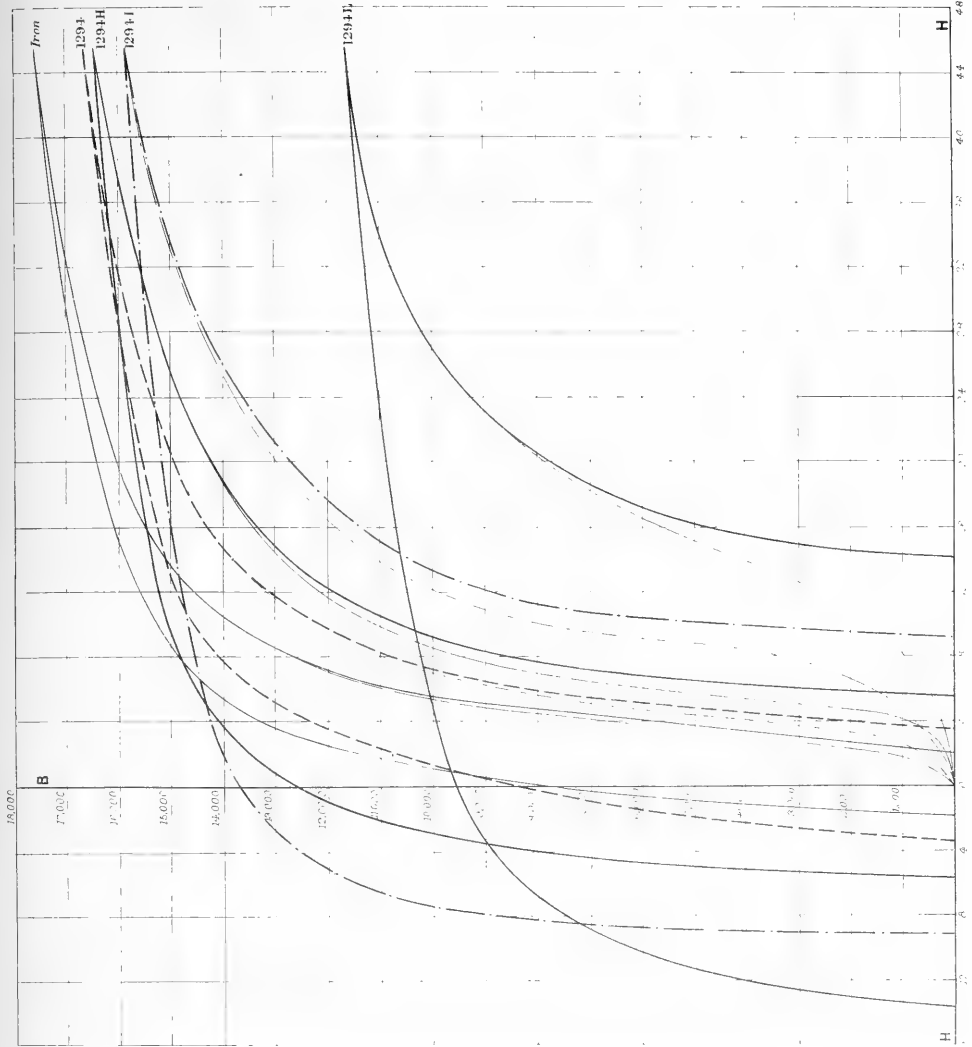



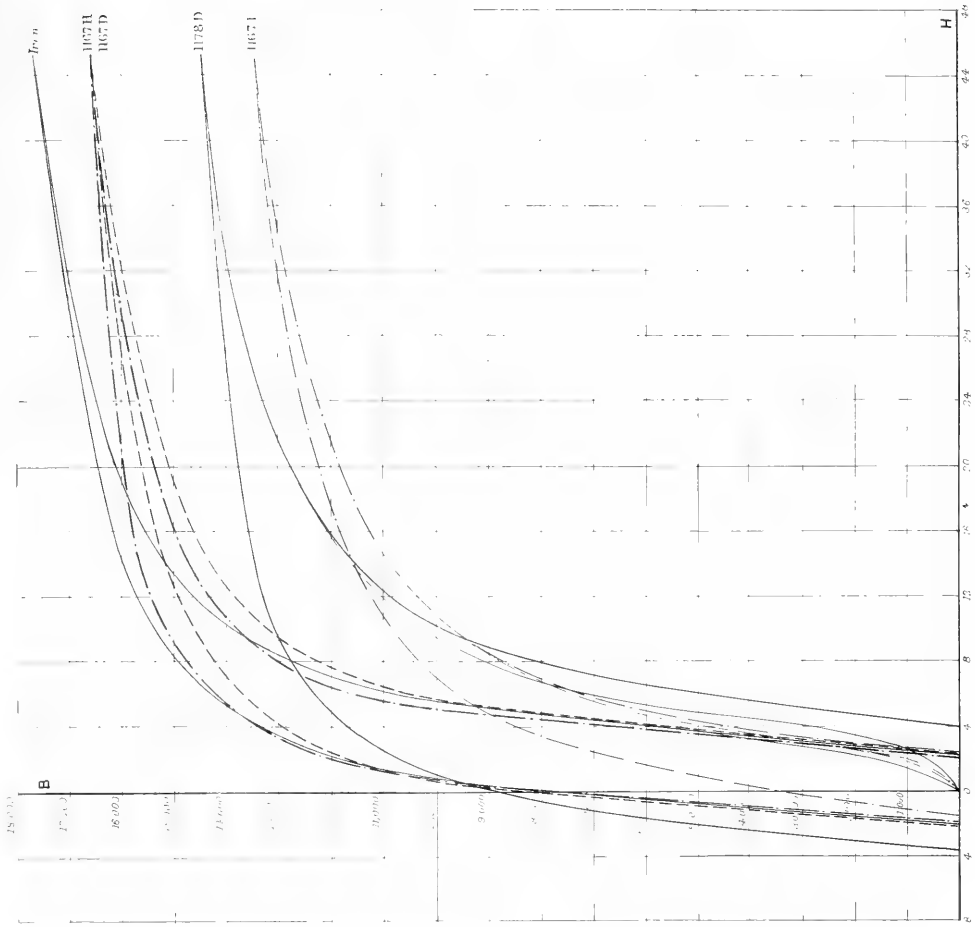



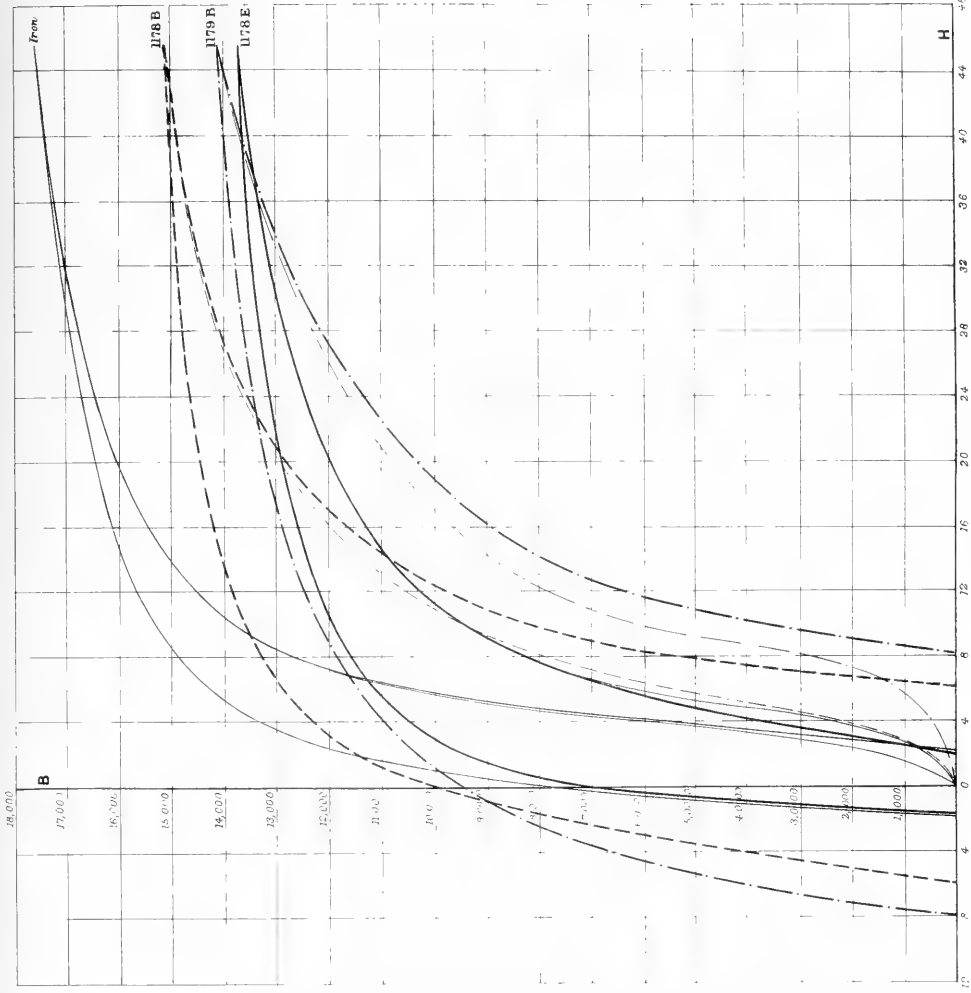

CHROMIUM - ALUMINIUM STEELS.

Met Herman Ltd.



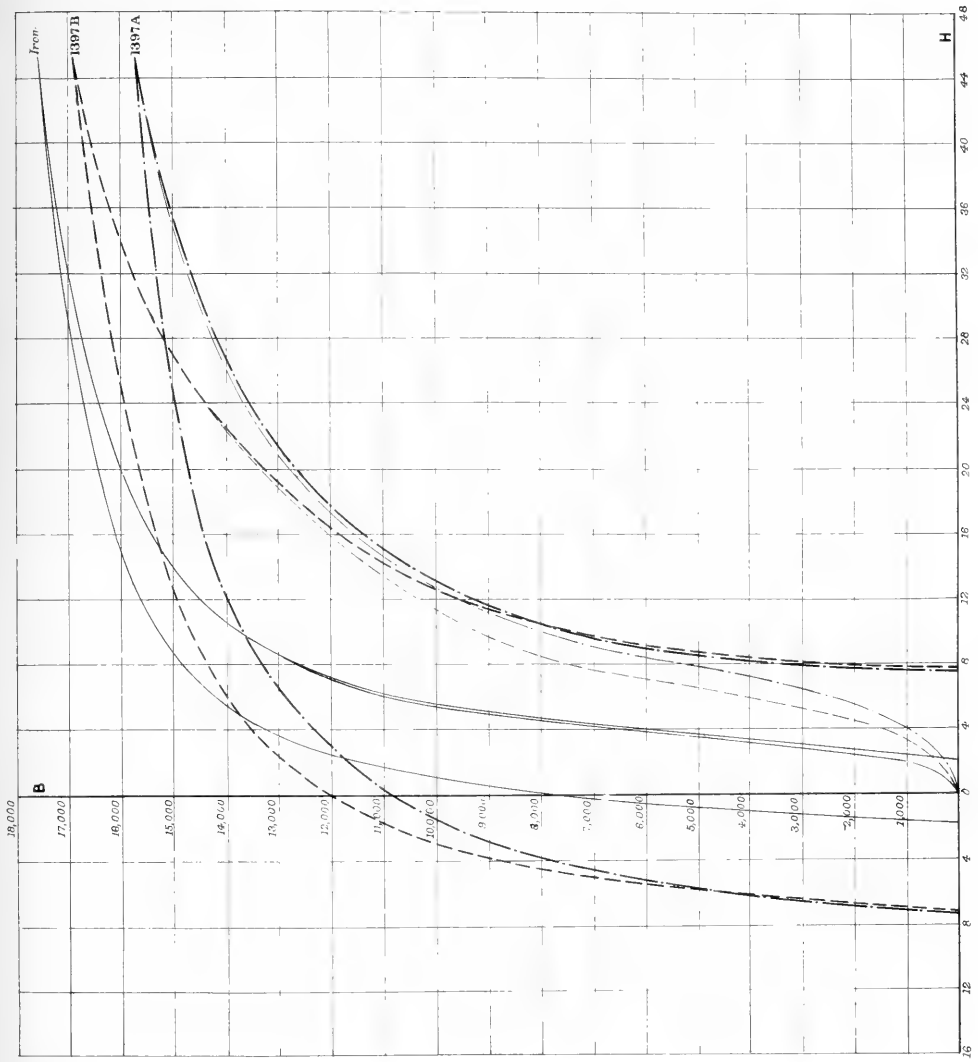

MANGANESE-SILICON STEELS.







## TRANSACTIONS (SERIES II.).

---

- VOL. I.—Parts 1-25.—November, 1877, to September, 1883.  
VOL. II.—Parts 1-2.—August, 1879, to April, 1882.  
VOL. III.—Parts 1-14.—September, 1883, to November, 1887.  
VOL. IV.—Parts 1-14.—April, 1888, to November, 1892.  
VOL. V.—Parts 1-13.—May, 1893, to July, 1896.  
VOL. VI.—Parts 1-16.—February, 1896, to August, 1898.
- 

### VOLUME VII.

**PART**

1. A Determination of the Wave-lengths of the Principal Lines in the Spectrum of Gallium, showing their Identity with Two Lines in the Solar Spectrum. By W. N. HARTLEY, F.R.S., and HUGH RAMAGE, A.R.C.SC.I. Plate I. (August, 1898.) 1s.
2. Radiating Phenomena in a Strong Magnetic Field. Part II.—Magnetic Perturbations of the Spectral Lines. By THOMAS PRESTON, M.A., D.SC., F.R.S. (June, 1899.) 1s.
3. An Estimate of the Geological Age of the Earth. By J. JOLY, M.A., B.A.I., D.SC., F.R.S., F.G.S., M.R.I.A., Honorary Secretary of the Royal Dublin Society; Professor of Geology and Mineralogy in the University of Dublin. (November, 1899.) 1s. 6d.
4. On the Electrical Conductivity and Magnetic Permeability of various Alloys of Iron. By W. F. BARRETT, F.R.S.; W. BROWN, B.Sc.; R. A. HADFIELD, M. Inst. C.E. Plates II. to IX. (January, 1900.) 4s.
5. On some Novel Thermo-Electric Phenomena. By W. F. BARRETT, F.R.S., Professor of Experimental Physics in the Royal College of Science for Ireland. Plate IXA. (January, 1900.) 1s.
6. Jamaican Actiniaria. Part II.—Stichodactylinæ and Zoantheæ. By J. E. DUERDEN, Assoc. R. C. Sc. (Lond.), Curator of the Museum of the Institute of Jamaica. Plates X. to XV. (January, 1900.) 3s.

[JANUARY, 1900.]

THE  
SCIENTIFIC TRANSACTIONS

OF THE

ROYAL DUBLIN SOCIETY.

VOLUME VII.—(SERIES II.)

---

V.

ON SOME NOVEL THERMO-ELECTRIC PHENOMENA.

By W. F. BARRETT, F.R.S.,

Professor of Experimental Physics in the Royal College of Science for Ireland.

(PLATE IXA.)

---

DUBLIN:  
PUBLISHED BY THE ROYAL DUBLIN SOCIETY.  
WILLIAMS AND NORGATE,  
14, HENRIETTA STREET, COVENT GARDEN, LONDON;  
20, SOUTH FREDERICK STREET, EDINBURGH; AND 7, BROAD STREET, OXFORD.  
PRINTED AT THE UNIVERSITY PRESS, BY PONSONBY AND WELDRICK.

1900.

---

*Price One Shilling.*

FRIST  
SEP  
SALE



## INDEX SLIP.

BARRETT, W. F.—On some Novel Thermo-Electric Phenomena.  
Roy. Dublin Soc. Trans., s. 2, vol. 7, 1900, pp. 127-132.

Thermo-Electric Phenomena, On some Novel.  
Barrett, W. F. Roy. Dublin Soc. Trans., s. 2, vol. 7, 1900, pp. 127-132.

1917

Journal of the

1917

[JANUARY, 1900.]

THE  
SCIENTIFIC TRANSACTIONS  
OF THE  
ROYAL DUBLIN SOCIETY.

VOLUME VII.—(SERIES II.)

---

V.

ON SOME NOVEL THERMO-ELECTRIC PHENOMENA.

By W. F. BARRETT, F.R.S.,

Professor of Experimental Physics in the Royal College of Science for Ireland.

(PLATE IXA.)

---

DUBLIN:  
PUBLISHED BY THE ROYAL DUBLIN SOCIETY.  
WILLIAMS AND NORGATE,  
14, HENRIETTA STREET, COVENT GARDEN, LONDON,  
20, SOUTH FREDERICK STREET, EDINBURGH; AND 7, BROAD STREET, OXFORD.  
PRINTED AT THE UNIVERSITY PRESS, BY PONSONBY AND WELDRICK.

1900.





## V.

## ON SOME NOVEL THERMO-ELECTRIC PHENOMENA.

By W. F. BARRETT, F.R.S.,

Professor of Experimental Physics in the Royal College of Science for Ireland.

(PLATE IXA.)

[Read FEBRUARY 22, 1899.]

IN the course of a determination of some of the physical properties possessed by various new alloys of iron, which had been prepared by Mr. R. A. Hadfield, of Sheffield, I found the thermo-electric behaviour of a particular nickel steel, to which five per cent. of manganese had been added, to be so remarkable that it seemed worthy of a separate note.

The analysis of this alloy (kindly supplied to me by Mr. Hadfield) was as follows:—

Iron, . . . .	68·8 per cent.
Nickel, . . . .	25·0 ,,
Manganese, . . . .	5·0 ,,
Carbon, . . . .	1·2 ,,

The specific electrical resistance of this alloy was found by Mr. Brown and myself to be higher than any other alloy we had hitherto examined.\* It amounted to no less than 97·52 microhms per cubic cent. (at 15° C.). At the same time its variation of resistance with change of temperature was comparatively small, the temperature coefficient being 0·08 per cent. per degree C. (between 0° and 250° C.).

The thermo-electric behaviour of the various alloys of iron which Mr. Hadfield had kindly placed in my possession was in course of investigation, and the enormous electrical resistance of this specimen, and of another similar alloy with somewhat less nickel, led me to try earlier than I should otherwise have done some of its other physical properties.

A preliminary experiment was made by coupling a wire of this new alloy successively with different metals and testing the thermo-electric power of the various junctions up to a red heat. When an iron wire was used as the second metal the thermo-electric force quickly rose till a certain temperature much below redness was reached, and then remained almost stationary, notwithstanding the

\* See Trans. R.D.S., Vol. VII., Part 4.

temperature of the junction rose from a black up to a bright white heat; the cool junctions being throughout kept in water at the temperature of the room, or in ice. Here, then, we have the thermo-electric force arrested when a certain temperature is reached, and remaining nearly the same in spite of the increasing difference of temperature between the cool and hot junctions. We know that so long as the *difference* of temperature between the cool and hot junctions in any thermo-couple remains constant, and the circuit is unchanged, the potential difference also remains constant; but if the difference of temperature between the cool and hot junctions alters, then the potential difference, as a rule, also changes; and for *small* changes of temperature the electro-motive force thus set up is, in most cases, proportional to the change of temperature. This, of course, is the principle upon which the thermo-electric pile is used as a delicate thermometer; and with certain alloys this proportionality holds good through a wide range of temperature.

In order to measure the exact temperature of the hot junction, a thermo-electric couple, formed of a platinum wire twisted with a wire of an alloy of platinum containing 10 per cent. of rhodium, was employed. With this couple the E. M. F. steadily rises, as the difference of temperature between the hot and cold junctions increases, through an enormous range of temperature. This pyrometer, devised by M. Chatelier, has the great advantage of occupying a very small space, and very rapidly assuming the temperature to which it is exposed. For pyrometric purposes, it is, of course, necessary first to plot a curve expressing the relation between temperature and the resulting E. M. F. This curve in the case of the Chatelier couple is approximately a parabola; but as Professor Callendar, F.R.S., has shown, in the course of his admirable researches on the platinum resistance pyrometer, the departure from a true parabolic curve is considerable when a wide range of temperature is to be measured by a Pt and Pt-Rh thermo-couple.\* The vapour of boiling water ( $100^{\circ}$  C.) and of boiling sulphur ( $445^{\circ}$  C.) are the most convenient and reliable fixed points for plotting the lower part of the scale.† For the higher parts I have used the freezing point of pure silver ( $961^{\circ}$  C.), and of potassium sulphate ( $1066^{\circ}$  C.).‡

A reflecting galvanometer was employed, a dead beat high-resistance instrument, of the D'Arsonval type, made by Ducretet, of Paris. Owing to its high resistance the alterations in the resistance of the circuit during the heating and cooling of the couple introduced no sensible error, the deflections being proportional to the E. M. F. and not to the current.

\* *Philosophical Magazine*, February, 1899.

† The thermo-couple must, of course, be protected from the sulphur by being enclosed in a hard-glass tube. To obtain the boiling-point of sulphur it is best to employ a hard-glass flask with a long neck, all except the lower portion of the flask being jacketed with asbestos. A convenient arrangement is supplied by the Cambridge Scientific Instrument Company, this I used.

‡ Heycock and Neville, *Trans. Chem. Society*, 1895.

The value of the scale-reading of the galvanometer in microvolts was accurately determined by means of a standard cell and potentiometer, one scale division being found to be equal to 26·5 microvolts. With a similar couple Professor Callendar found the E. M. F. in microvolts at three points ought to be as follows:—

100° C.	.	.	.	650 microvolts
445°	.	.	.	3630 „
1000°	.	.	.	9550 „

the other junctions being in ice. My own determinations at 100° C. and 445° C. gave almost identically the same values in microvolts; this may be accidental, but the variations of thermo-electric power in different specimens of platinum is probably very slight. I therefore took Professor Callendar's value in microvolts for 1000° C. in preference to the rather different number I obtained.\* The results are plotted in the curve shown in Plate IX*a*, marked "pyrometer couple."

We will now return to the thermo-electric behaviour of this nickel-manganese-iron alloy. An iron wire, drawn from the purest commercial iron, was coupled with a wire of the alloy. The wires were twisted together at the junction and then brazed. After insulation with asbestos they were lashed alongside of the platinum-rhodium pyrometer couple, and the pair of couples were then inserted in the centre of a thick iron tube held horizontally in, and heated by, a gas furnace, the temperature of which could be raised to a white heat. The cooler junctions of both couples were kept in ice, and pairs of readings were taken as the temperature was raised, and again as it was lowered; the rise and fall being slow and steady in both cases. As the readings of each couple were taken alternately, to obtain a true comparison three readings were necessary in each case, first, of one couple *A*; then, of the other *B*; then, of *A* again; the mean of the first and last readings of *A* being comparable with *B*. The galvanometer being extremely dead-beat, all three readings could be taken closely together. This comparison was repeated two or three times every minute during heating and cooling, thus several series of readings for about every 10° C. rise or fall of temperature were obtained; the readings which corresponded to similar temperatures in heating and cooling being remarkably concordant, allowance being made for a very small constant difference to be mentioned in the sequel.

The results are plotted in the second curve shown on Plate IX*a*. It will be seen that, up to a temperature of 320° C., the E. M. F. of the nickel-steel alloy and iron couple rose rapidly; it then remained absolutely constant until

\* As (within the limits of the scale) the E. M. F. of the thermo-couple is directly proportional to the scale-readings of the galvanometer, it is easy, when the E. M. F. in microvolts at 100° and 445° C. is found, to determine the higher points in the curve by means of the ratio given above: the scale-readings being plotted as ordinates and the temperatures as abscissæ.

the temperature rose to  $500^{\circ}$ , and after this, only a small change occurred up to the highest temperature attainable in the gas furnace employed. The mean E. M. F. between  $300^{\circ}$  and  $1000^{\circ}$  C., being in round numbers 4000 microvolts, and the extreme variations from the mean E. M. F. throughout this range of  $700^{\circ}$  C.,—that is, from a low black heat to a white heat, being less than 170 microvolts, or about + and - 4 per cent. of the E. M. F. at  $300^{\circ}$  C., the cooler junction being kept at  $0^{\circ}$  C. It will be noticed there is a slight and curious oscillation of the E. M. F. about the mean line between  $300^{\circ}$  and  $1100^{\circ}$  C., the curve cutting the mean E. M. F. at four points, viz., at  $310^{\circ}$ ,  $540^{\circ}$ ,  $810^{\circ}$ , and  $1030^{\circ}$  C.

The couple was next exposed to a very low temperature obtained from solid  $\text{CO}_2$ , but though a temperature of  $-80^{\circ}$  C. was reached (the other junction being still kept in melting ice), no other anomalous action occurred, the reverse E. M. F. increasing rapidly as the temperature fell. On again raising the temperature to a white heat, the phenomena previously observed were exactly reproduced, and continued to be so on repeated heating and cooling.

In place of nearly pure iron, other substances were tried as the second metal in conjunction with this alloy. Ordinary commercial iron wire gave a very similar result, the oscillations from the mean E. M. F. being slightly greater. With an ordinary mild steel wire as the second metal, the nickel manganese alloy now gave a different result; this is shown on the lower curve in the Plate. The E. M. F. is less, remains constant only between  $400^{\circ}$  and  $600^{\circ}$  C.; then begins to fall and continues falling slowly to the highest temperature reached, over  $1000^{\circ}$  C.

Platinum, copper, and other metals were also tried in conjunction with this alloy, but in no case was there observed the singular constancy of E. M. F. through a wide range of temperature which occurred when iron was the second metal. With platinum, the E. M. F. has an opposite sign (to that occurring when the alloy is coupled with iron) up to a temperature of  $210^{\circ}$  C.; inversion takes place at this temperature, after which the E. M. F. rapidly rises with increasing temperature in an approximately parabolic curve.

A small thermo-electric battery was formed of strips of this alloy with strips of iron, the strips being insulated by asbestos, and brazed at their junctions; 25 of these couples give an E. M. F. of  $\frac{1}{10}$  of a volt when heated over any flame, the cooler junctions being kept in ice-cold water. A convenient standard of E. M. F. might thus be made if the mean of the readings between  $300^{\circ}$  and  $1000^{\circ}$  C. are taken. Whether repeated heating and cooling of the alloy will affect its E. M. F. I cannot say, but I have not yet observed any injury resulting from this cause.

We know so little of the whole subject of thermo-electricity, that the explanation of the remarkable behaviour of this alloy can only be a matter for conjecture. Some light may be thrown on it by the results obtained from the other alloys of iron, when their thermo-electric behaviour is examined. So far I

have found that reducing the nickel in the alloy from 25 to 19 per cent., the other constituents remaining the same, does not destroy the sudden arrest of E. M. F. at about 300° C.; but the range of temperature where the E. M. F. is nearly constant is less, extending from about 400° to 750° C.

It has been suggested that the peculiar thermo-electric property of this alloy may be connected with the effect observed by Lord Kelvin, the so-called Thomson effect, whereby a kind of electric convection of heat occurs. It is very possible that it may have some connexion with this, and hence with the *neutral point*, which occurs in the thermo-electric behaviour of certain pairs of metals, such as copper and iron. It is well known that at a certain critical difference of temperature between the hot and cold junctions of, say, a copper-iron couple, the potential difference due to heat disappears; as the temperature rises, inversion of the current occurs; and a second inversion may occur at a still higher temperature. In the phenomenon described in this paper, the E. M. F., it is true, does not fall to zero. If, however, the cooler junction were kept at a temperature of 310° C., this would be the case; and we should then have a series of three successive small inversions of E. M. F., occurring at 540°, 810°, and 1030° C. In a copper-iron couple the neutral point is 275° C., that is to say, no E. M. F. is produced by heat when one of the junctions is as much *above* 275° as the other is *below* that temperature, the neutral point being the arithmetic mean of the temperatures of the hot and cold junctions. If, therefore, the cold junction in a copper-iron couple be kept at 0° C., the thermo-electric current falls to zero when the hot junction is at 550° C., the current being inverted as the temperature rises beyond this.

I have noticed that the temperature of the neutral point in a copper-iron, or copper-steel couple, is not the same during the *heating* as during the *cooling* of the couple. Moreover, in a couple formed of copper and mild carbon steel, the neutral point becomes lower in successive heatings. Thus, at the *first* heating the temperature of inversion was approximately 640° C., and in cooling, 500° C.; in the *second* heating, 550° C., and in cooling, 465° C.; in the *third* heating, 520° C., and in cooling, 465° C. The difference between the temperature of inversion in heating and cooling becoming less in each successive heating and cooling. The cool junction was here at 16° C. throughout, the neutral points at the 1st, 2nd, and 3rd heatings and corresponding coolings of the couple, would therefore be approximately as follows:

*Neutral points of copper-steel couple.*

	First,	Second,	Third Heating.
When heating, . . .	328°	283°	268° C.
When cooling, . . .	258°	241°	241° C.

It is obvious, therefore, that the curve representing the thermo-electric force of

a copper-steel couple at different temperatures is not the same for a rising as for a falling temperature. This I have found to be the case with couples formed of several other metals, provided one element of the couple is iron or steel or other alloy of iron. When the other metal is platinum, the difference in the two curves is well seen, though with a platinum-iron couple, the difference of E. M. F. in heating and cooling is less marked than with a platinum-steel couple. In the latter case, a considerable area is enclosed by the curves (representing the relation between thermo-electric force and temperature) during heating and during cooling. Hence, at a given temperature, say  $500^{\circ}$  C., of the hot junction, the E. M. F. of a platinum-steel couple is considerably *higher* during heating than during cooling.

The reverse is the case with a couple formed of Hadfield's nickel-manganese-steel and copper, or a couple formed of the same alloy with platinum; in both these cases at any given temperature, the E. M. F. is *lower* during heating than during cooling. With a couple formed of the same alloy and iron, as described in the earlier part of this paper, there is also a slightly lower E. M. F. at corresponding temperatures during heating than during cooling, but the difference only exists at certain parts of the scale, and is so small that it could not be shown on the curve as reduced in the Plate. With the nickel-manganese-steel alloy mentioned on the top of p. 115 (containing 19 instead of 25 per cent. of nickel) coupled with iron, the E. M. F. is slightly *higher* at corresponding temperatures in heating than in cooling up to the level part of the curve, *i.e.* about  $400^{\circ}$  C., where the E. M. F. becomes almost the same in heating as in cooling—very slightly lower, however—and remains so until the curve rises, when the E. M. F. again becomes higher at corresponding temperatures in heating than in cooling up to the highest temperature reached: in this case, therefore, the curves showing the E. M. F. during heating and cooling cross each other twice, first at about  $400^{\circ}$  and next about  $800^{\circ}$  C.

I hope, in a subsequent paper, to give the results of further investigation which I am pursuing on this interesting phenomenon, together with the curves for the E. M. F. of various couples during heating and cooling—*thermo-electric hysteresis curves* as they may be called.\* It is very probable that the peculiar thermo-electric deportment of iron, and some of the alloys of iron described in this paper, is intimately associated with the phenomenon of recalescence, or rather of the series of recalescent points which exist in iron and steel.

\*As was pointed out by Professor G. F. FitzGerald, F.T.C.D., F.R.S., at the meeting of the Society when this paper was read, the thermo-electric hysteresis here referred to is, no doubt, the cause of the thermo-current which is produced in an iron wire steadily moved through a flame, a phenomenon first noticed and investigated by Dr. F. T. Trouton, F.R.S. See *Proc. Royal Dublin Society*, March, 1886. I am also greatly indebted to Professor FitzGerald for other suggestions he has made in reading the proof of this paper.

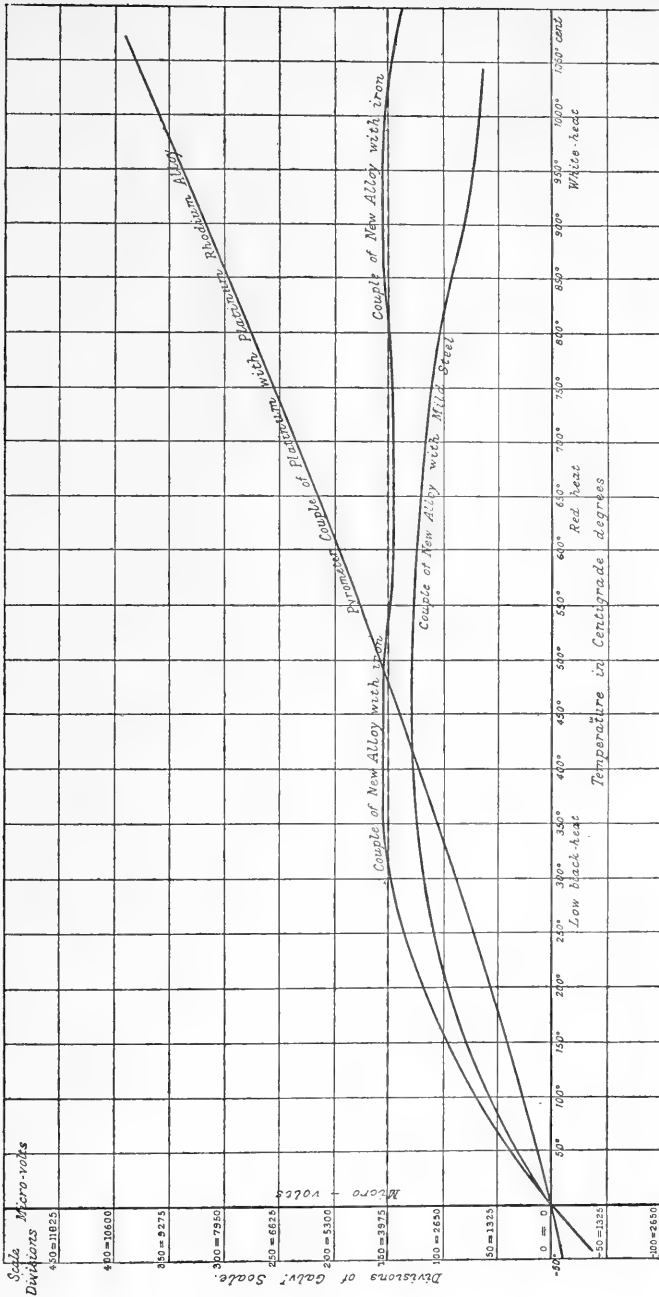

THERMO-ELECTRIC CURVES OF HADFIELD'S NICKEL-MANGANESE-STEEL ALLOY.





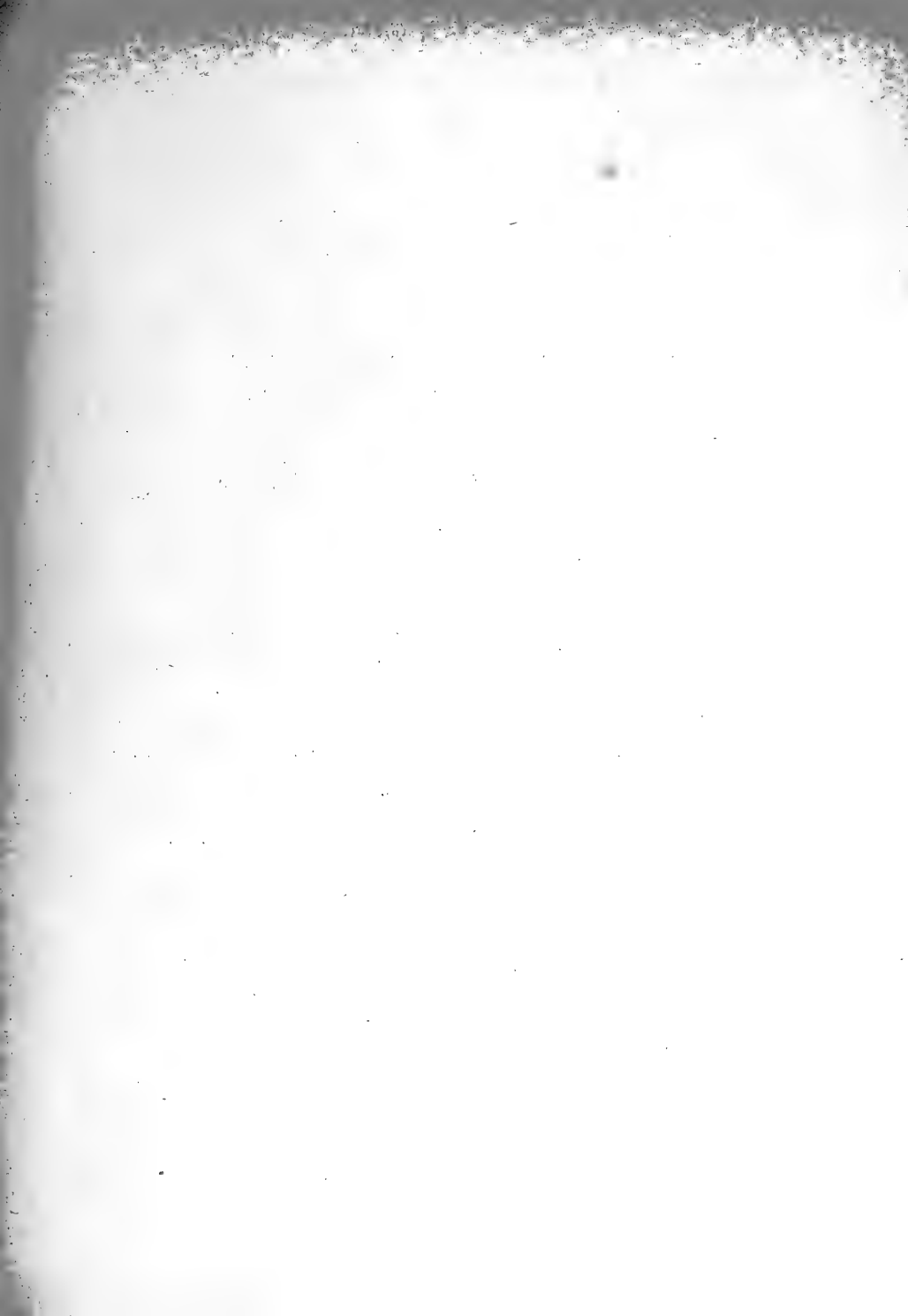

## TRANSACTIONS (SERIES II.).

---

VOL. I.—Parts 1-25.—November, 1877, to September, 1883.

VOL. II.—Parts 1-2.—August, 1879, to April, 1882.

VOL. III.—Parts 1-14.—September, 1883, to November, 1887.

VOL. IV.—Parts 1-14.—April, 1888, to November, 1892.

VOL. V.—Parts 1-13.—May, 1893, to July, 1896.

VOL. VI.—Parts 1-16.—February, 1896, to August, 1898.

---

### VOLUME VII.

#### PART

1. A Determination of the Wave-lengths of the Principal Lines in the Spectrum of Gallium, showing their Identity with Two Lines in the Solar Spectrum. By W. N. HARTLEY, F.R.S., and HUGH RAMAGE, A.R.C.S.C.I. Plate I. (August, 1898.) 1s.
2. Radiating Phenomena in a Strong Magnetic Field. Part II.—Magnetic Perturbations of the Spectral Lines. By THOMAS PRESTON, M.A., D.SC., F.R.S. (June, 1899.) 1s.
3. An Estimate of the Geological Age of the Earth. By J. JOLY, M.A., B.A.L., D.SC., F.R.S., F.G.S., M.R.I.A., Honorary Secretary of the Royal Dublin Society; Professor of Geology and Mineralogy in the University of Dublin. (November, 1899.) 1s. 6d.
4. On the Electrical Conductivity and Magnetic Permeability of various Alloys of Iron. By W. F. BARRETT, F.R.S.; W. BROWN, B.Sc.; R. A. HADFIELD, M. Inst. C.E. Plates II. to IX. (January, 1900.) 4s.
5. On some Novel Thermo-Electric Phenomena. By W. F. BARRETT, F.R.S., Professor of Experimental Physics in the Royal College of Science for Ireland. Plate IXA. (January, 1900.) 1s.
6. Jamaican Actiniaria. Part II.—Stichodactylinae and Zoantheae. By J. E. DUERDEN, Assoc. R. C. Sc. (Lond.), Curator of the Museum of the Institute of Jamaica. Plates X. to XV. (January, 1900.) 3s.

[JANUARY, 1900.]



THE

SCIENTIFIC TRANSACTIONS

OF THE

ROYAL DUBLIN SOCIETY.

VOLUME VII.—(SERIES II.)

---

VI.

JAMAICAN ACTINIARIA. PART II.—STICHODACTYLINÆ AND ZOANTHÆÆ.

By J. E. DUERDEN, Assoc. R. C. Sc. (Lond.), Curator of the Museum of the Institute of Jamaica.

(PLATES X. TO XV.)

---

DUBLIN:

PUBLISHED BY THE ROYAL DUBLIN SOCIETY.

WILLIAMS AND NORGATE,

14, HENRIETTA STREET, COVENT GARDEN, LONDON,

20, SOUTH FREDERICK STREET, EDINBURGH; AND 7, BROAD STREET, OXFORD.

PRINTED AT THE UNIVERSITY PRESS, BY PONSONBY AND WELDRICK.

1900.

---

*Price Three Shillings.*



INDEX SLIP.

DUERDEN, J. E.—Jamaican Actinaria. Part II. Stichodactylinae and Zoanthes.  
Roy. Dublin Soc. Trans., s. 2, vol. 7, 1900, pp. 133-220.

Actinaria, Jamaican.  
Duerden, J. E.  
Roy. Dublin Soc. Trans., s. 2, vol. 7, 1900, pp. 133-220.

1707 211

1707 211 - 1707 211

1707 211 - 1707 211

[JANUARY, 1900.]

THE  
SCIENTIFIC TRANSACTIONS  
OF THE  
ROYAL DUBLIN SOCIETY.

VOLUME VII.—(SERIES II.)

---

VI.

JAMAICAN ACTINIARIA. PART II.—STICHODACTYLINÆ AND ZOANTHEÆ.

By J. E. DUERDEN, Assoc. R. C. Sc. (Lond.), Curator of the Museum of the Institute  
of Jamaica.

(PLATES X. TO XV.)

---

DUBLIN:  
PUBLISHED BY THE ROYAL DUBLIN SOCIETY.  
WILLIAMS AND NORGATE,  
14, HENRIETTA STREET, COVENT GARDEN, LONDON,  
20, SOUTH FREDERICK STREET, EDINBURGH; AND 7, BROAD STREET, OXFORD.  
PRINTED AT THE UNIVERSITY PRESS, BY PONSONBY AND WELDRICK.

1900.





## VI.

## JAMAICAN ACTINIARIA. PART II.—STICHODACTYLINÆ AND ZOANTHÆ.

By J. E. DUERDEN, Assoc. R. C. Sc. (Lond.), Curator of the Museum of the Institute of Jamaica.

(PLATES X. TO XV.)

[Read DECEMBER 21, 1898.]

THE first instalment of this series (1898) was limited to the Zoanthæ occurring in the shallow waters around Jamaica, and ten species are described therein. As a result of trawling recently carried on over some of the deeper regions of the Caribbean Sea three other species of the same order, all belonging to the one genus *Parazoanthus*, have been procured. The account of these is included at the end of the present contribution.

This second communication describes seven species belonging to the mainly tropical order *Stichodactylinæ*. Several have already been anatomically studied and described by Professor M<sup>c</sup>Murrich in his "Actinaria of the Bahamas" (1889); and it is interesting to compare the many points of resemblance and difference as revealing the features of stability or of variation within the same form.

When the paper was practically completed I received the extremely valuable memoir by Professor A. C. Haddon, "The Actinaria of Torres Straits" (1898), in which, besides describing fifty-five species from that particular locality, the author attempts a classificatory revision of the whole group.

Torres Straits has proved itself extremely rich in *Stichodactylinæ*. In so far as my results agree with those of Professor Haddon, I have been enabled to bring the present contribution into harmony with his conclusions.

Mention must also be made of Dr. Casimir R. Kwietniewski's "Actinaria von Ambon und Thursday Island" (1898), an important paper also devoted to tropical Actiniæ, published while Haddon's memoir was going through the press, and therefore not referred to by him.

As it is not likely that Professor Haddon will, for some time, conduct other such elaborate investigations in this branch of zoology, he has most generously placed at my disposal his microscopic preparations of species already described by him, and has also lent me portions of his extensive collection of Actinozoan literature, favours specially appreciated in such an isolated position. For these, and for other encouraging help, I here beg to express my sincerest gratitude.

The present species are arranged as follows :—

Tribe.—HEXACTINIÆ, Hertwig.

Order.—STICHODACTYLINÆ, Andres.

Sub-order.—HETERODACTYLINÆ, n. s.-o.

Family.—PHYMANTHIDÆ, Andres.

Genus.—PHYMANTHUS, Milne Edwards.

*Phymanthus crucifer* (Lesueur).

Family.—RHODACTIDÆ, Andres.

Genus.—ACTINOTRYX, Duchassaing and Michelotti.

*Actinotryx Sancti-Thomæ*, Duchassaing & Michelotti.

Sub-order.—HOMODACTYLINÆ, n. s.-o.

Family.—DISCOSOMIDÆ, Klunzinger.

Genus.—RICORDEA, Duchassaing & Michelotti.

*Ricordea florida*, Duchassaing & Michelotti.

Genus.—STOICHACTIS, Haddon.

*Stoichactis helianthus* (Ellis).

Genus.—HOMOSTICHANTHUS, n. g.

*Homostichanthus anemone* (Ellis).

Genus.—ACTINOPORUS, Duchassaing.

*Actinoporus elegans*, Duchassaing.

Family.—CORALLIMORPHIDÆ, Hertwig.

Genus.—CORYNACTIS, Allman.

*Corynactis myrcia* (Duchassaing & Michelotti).

Tribe.—ZOANTHÆ, Hertwig.

Family.—ZOANTHIDÆ, Dana.

Sub-family.—MACROCNEMINÆ, Haddon & Shackleton.

Genus.—PARAZOANTHUS, Haddon and Shackleton.

*Parazoanthus tunicans*, n. sp.

„ *monostichus*, n. sp.

„ *separatus*, n. sp.

## Tribe.—HEXACTININÆ, Hertwig, 1882.

Actiniaria with paired mesenteries. The mesenteries of each pair are provided with longitudinal muscular fibres on the faces turned towards each other, and with transverse muscles on the faces turned away from each other, except in the case of two (sometimes more, one or none) pairs—the directives—in which this arrangement of the musculature is reversed, so that the longitudinal muscles are on the faces which look away from each other. The number of pairs of perfect mesenteries is at least six, but may be eight, ten, or irregular, and they usually increase simultaneously in the same multiples.

The above definition is, in the main, that adopted by all writers since Professor R. Hertwig founded the tribe. As a result, however, of later investigations it has been found that exceptions may occur in almost every part of the original definition. Many forms are now known in which the hexamerous symmetry is replaced by an octamerous, decamerous, or irregular arrangement; the directives may be absent, reduced to only one pair, or increased to more than two pairs. Even the increase in pairs of the cycles beyond the primary does not always proceed in regular multiples of the latter, or simultaneously. This is shown in *Ricordea florida* (Pl. XI., fig. 6; Pl. XII., fig. 1), where the pairs of the third cycle are developed very irregularly and never in proper alternation, *i.e.* double the number of the first or second cycle, as the rule of symmetry demands; the hexamerous plan is here likewise departed from.

Gonidial or oesophageal grooves, included by Hertwig in his definition, are now known to be so variable in number, or even to be absent in so many cases, that their inclusion in the tribal definition is of no importance. Dr. O. Carlgren (1893) adds that the column-wall and stomodæum are devoid of ectodermal longitudinal muscular and ganglionic layers, but, in the present paper, these are shown to occur in several species, and are already known for several others.

## Order.—STICHODACTYLINÆ, Andres, 1883.

Hexactininae in which more than one tentacle may communicate with a mesenterial chamber. Usually a peripheral series of one or more cycles can be distinguished from an inner accessory series, the members of which are radially arranged or in groups, and are often of different form. Sphincter muscle either endodermal or absent.

The division of the tribe Hexactininae into the two orders, Actininae (in which

only a single tentacle communicates with a mesenterial chamber) and Stichodactylinae (in which more than one tentacle may communicate with a mesenterial chamber), has the advantage of being founded upon an external character which can be readily observed, and which must certainly be regarded as of some fundamental importance in Actinian morphology.

For better comparison of the tentacular relationships, I give a plan of a portion of the disc in each case.

It is doubtful as to how far the Stichodactylinous condition is homologous throughout the order, for important differences obtain in each of the seven species to be described.

In the Phymanthidæ the marginal tentacles are in numerous, alternating, entacmæous cycles, arranged exactly as are the tentacles in the Actiniæ. The inner, so-called tentacles are nothing more than mere discal tubercles, more or less irregularly arranged, and histologically differ entirely from the outer series. From the evidence afforded by its peripheral tentacles, I regard the family as approaching the Actiniæ more closely than any of the others.

The arrangement is somewhat similar in Actinotryx, but the marginal tentacles are all in a single cycle, though they probably represent two or three series for some reason not separated centripetally. The disc tentacles are irregularly arranged with regard to the mesenterial chambers; and their dendritic form is perhaps but an exaggeration of the tubercular tentacle of Phymanthus. The arrangement of the outer and inner groups in Actinotryx recalls that in Corallimorphus, though the form of the tentacles presents a great contrast.

The case of Corynaectis is otherwise. So far as my experience goes, no distinction can be made between a peripheral and an inner series, though Haddon (1898, p. 466) makes a generic character of such a separation. The tentacles in each radial series follow one another in regular sequence, and afford the same histological details, pointing to a common origin; the relative sizes are, however, the reverse of those in the Actiniæ, *i.e.* the inner are the smaller, and the outer the larger.

A somewhat similar arrangement holds in the genera Stoichactis and Ricordea. The tentacles in the same radial row follow one another in a regular manner; but with regard to the conditions at the margin, however, the species vary. In *Stoichactis helianthus* a single outermost cycle alternates with all the radial rows. In *Ricordea florida*, on the other hand, the outermost cycle but one alternates with all the rows within, and with the cycle peripheral to it; these two marginal cycles are somewhat larger, and are often of a colour distinct from that of the inner tentacles.

Homostichanthus possesses about a dozen outer cycles of tentacles, often distinguished from the inner series by the innermost cycle being differently

coloured from all the rest. They are all, however, on the same radii as the inner rows, which are not cyclic.

In Actinoporus the tentacles are simple or lobed vesicles, are practically all alike, and occupy all the radial divisions, two or more irregular rows communicating with the same mesenterial chamber.

Where the tentacles are so crowded, some of these relationships and distinctions are not easily recognized in contracted, preserved specimens. In living polyps, they can more readily be made out, often facilitated by colour distinctions.

I think it is desirable to have some division expressive of the similarity, or otherwise, of the tentacles in any genus, and therefore propose the following Sub-orders:—

#### HETERODACTYLINÆ.

Stichodactylinae, in which the tentacles are of two forms, usually marginal and accessory, and separated by a naked portion of the disc. *Examples*—Phymanthus, Actinotryx, Rhodactis, Cryptodendron, Heterodactyla.

#### HOMODACTYLINÆ.

Stichodactylinae, in which the tentacles are all of one kind, simple or complex, and usually follow one another in continuous rows. *Examples*—Discosoma, Ricordea, Stoichactis, Radianthus, Corynaetis, Homostichanthus, Actinoporus.

Generally the more central tentacles are smaller or less complex than the more peripheral, but within the same species they are all formed on one plan.

Dr. Carlgren (1891, 1893) has erected the tribe Protantheæ, of which the most salient character is that the column-wall and stomodæum possess an ectodermal ganglion and longitudinal muscle layer. First formed to include the genera Gonaetinia and Protanthea, in his later paper he embraces *Thaumactis medusoides*, Fowler, and the genera Corynaetis and Corallimorphus, representing the families Thaumactinidæ and Corallimorphidæ respectively. *Thaumactis* has since been shown by Professor Haddon and myself (1896, p. 158) to be included in the family Aliciidæ, and I do not consider the presence of an ectodermal musculature of sufficient importance to warrant the separation of the Corallimorphidæ from its more natural place among the Stichodactylinae.

A columnar and stomodæal ectodermal musculature and nerve layer are now known for many Hexactinidæ, the other characters of which indicate that they belong to totally different families. Professor M<sup>c</sup>Murrich (1893, p. 143) refers to the probable occurrence of an ectodermal musculature in *Halcurias pilatus*; I have recorded it (1897) in two species of *Bunodeopsis*, and describe its presence in

several of the forms to follow. From his paper just received, I find that Professor Haddon and myself have independently come to the same conclusion with regard to the degree of importance to be attached to these histological details. In the same contribution Haddon discusses at some length the points at issue between Carlgren's tribe PROTANTHÆ and the PROTACTINIÆ of M<sup>c</sup>Murrich.

Regarding it as a relic from the ancestral Scyphistoma, Haddon (p. 411) considers that the ectodermal columnar and stomodæal musculature may persist amongst the lowest, *i.e.* the least specialized, members of various groups. This view of its significance is further supported by the fact that it is often associated with a practically homogeneous mesogloæa, and sometimes with the absence of the "Flimmerstreifen" of the mesenterial filaments. Such is the case in *Corynactis* and *Ricordea*, and partly so in *Cerianthus*, in each of which an ectodermal musculature occurs; but in *Phymanthus*, and one or two others where the same structure is also developed, the mesogloæa is fibrous and includes numerous cells.

In a recent paper (1898), I have endeavoured to show that the combination of external and anatomical features met with in several of the Stichodactylinæ here described, are such as are also characteristic of the Madreporaria.

Sub-order.—HETERODACTYLINÆ, n. s.-o.

Family.—PHYMANTHIDÆ, Andres.

- Thalassianthinæ*, . . . (pars), M. Edwards, 1857.  
*Phyllactinæ*, . . . (pars), Klunzinger, 1877.  
*Phymanthidæ*, . . . Andres, 1883; M<sup>c</sup>Murrich, 1889; Kwietniewski, 1898; Haddon, 1898.

Stichodactylinæ, in which the tentacles are of two kinds: marginal tentacles arranged in several alternating entacmæous cycles, laterally tuberculiferous, or frondose; inner tentacles radially or irregularly arranged, very small, tubercular or papilliform.

Genus.—PHYMANTHUS, Milne Edwards.\*

- Actinia*, . . . (pars), Lesueur, 1817.  
*Actinodendron*, . . . (pars), Ehrenberg, 1834.  
*Phymanthus*, . . . Milne Edwards, 1857; Klunzinger, 1877; Andres, 1883; M<sup>c</sup>Murrich, 1889; Kwietniewski, 1898; Haddon, 1898.

\* While this contribution was going through the press I received from Prof. A. E. Verrill a copy of his paper: "Descriptions of new American Actinians, with critical notes on other species, I." Amer. Journ. Science, vol. vi., 1898, pp. 493-498. In connexion with the genus of the species here referred

Phymanthidæ, in which the column is provided with longitudinal rows of verrucæ in its upper part, and terminated by a cycle of rounded acrorhagi. Sphincter muscle endodermal and very feeble, or absent. An ectodermal muscular and nervous layer are often present on the column-wall and stomodæum.

Professor Haddon (1898, p. 495) separates the genus *Thelaceros*, of Chalmers Mitchell (1890), from *Phymanthus*, solely on account of the absence of verrucæ on its column-wall. Kwietniewski (1898, p. 419), on the other hand, includes his species, *P. levis*, under the genus, although devoid of these structures, and places *Thelaceros* as a synonym of *Phymanthus*. It is clearly a matter of little moment which limitation is followed. As demonstrating the relationship of the two, it is important to note that Mitchell (p. 555) found a thick ectodermal musculature on the stomodæum of his Celebes representative.

***Phymanthus crucifer* (Lesueur).**

(Pl. x., figs. 1 and 2; Pl. xi., figs. 1 and 2.)

*Actinia crucifera*, . . . Lesueur, 1817, p. 174.

*Cereus crucifer* (*Actinia*), Duchassaing and Michelotti, 1866, p. 125; pl. vi., fig. 13.

*Phymanthus cruciferus*, . . . Andres, 1883, p. 501.

*Phymanthus crucifer*, . . . McMurich, 1889, p. 51, pl. ii., fig. 1; pl. iv., figs. 6-11.

With the exception of the oral disc, the polyps are usually buried in coral sand, or gravel; the pedal disc is firmly adherent to rocks and stones, and adapts itself to the irregularities of their surface. In preserved specimens the base is flat, with coarse radial, and fine circular wrinklings, and is a little larger in diameter than the proximal region of the column.

The column is erect and smooth in the living condition, but exhibits coarse transverse and vertical wrinklings in contracted preserved specimens. When alive, the polyps are somewhat trumpet-shaped, expanding very slowly from the narrow region just above the limbus, until, in the upper region, they extend to two or three times their lower diameter. Distally the column is folded, and, *in situ*, this region rests upon the surface of the coral sand. The column is very thin-walled, and the lines of attachment of the mesenteries show through.

to, Prof. Verrill remarks (p. 496): "The generic name *Epicystis* [Ehr., Corall. rothen Meeres, p. 144, 1834] was proposed for the *Actinia crucifera* Les., *A. ultramarina* Les., and *A. granulifera* Les., the first being put in sect. *a*. Therefore, it is necessary to take the former as the type of the genus, which is evidently entirely distinct from the true *Phymanthus*.

Four to six very distinct, sucker-like verrucæ are developed in each row, and a few smaller examples may be continued below; the larger are capable of attaching pieces of fine gravel, fragments of shells, etc., to the column. The rows of verrucæ correspond with only certain of the mesenterial divisions as seen externally, and sometimes a single apical verruca may alternate with the principal rows.

A circle of prominent, rounded acrorhagi occurs at the apex of the column; these are double in number the rows of verrucæ, and alternate with the outermost row of tentacles. Sometimes a smaller acrorhagus alternates with the larger. A shallow fossa intervenes between the cycle of acrorhagi and the commencement of the tentacular region.

The peripheral tentacles are numerous, slightly entacmæous, shortly conical, and overhanging, the oral face being longer than the external. The number varies; the normal arrangement appears to be 6, 6, 12, 24, 48, &c.; one specimen bore 19, instead of 15, enclosed within the radii from two tentacles of the first cycle; the tentacles of many small polyps were counted in which the normal 96 were present, while in one specimen the irregular number 106 occurred (Pl. x., fig. 1).

In the majority of polyps, the tentacles bear several transverse, opaque thickenings, most strongly developed along the oro-lateral area of the tentacles, where a distinct bilobation is often observable (Pl. x., fig. 2). Six or seven pairs of tubercles, arranged pinnately, may be present on the larger tentacles, diminishing a little in prominence both proximally and distally. The tentacles are smooth for some little distance from their origin, and remain so throughout their outer concave aspect.

Many polyps were procured wholly destitute of the thickenings, the tentacles being quite smooth, differently coloured, and presenting an entirely distinct appearance from the usual form. At first I had no hesitation in regarding these as a second species; but an acquaintance with scores of specimens, all living within the same area, revealed every stage in the presence or absence of the tubercles, some examples having only odd tentacles smooth, while others have only a few tuberculated.

The disc is very large, thin-walled, and, periphally, is thrown into 8–12 folds, and may overhang the column to a great extent; its middle region is flat, or may be slightly convex. The surface of the disc is characterized by the presence of small, wart-like projections, varying in size and arranged mostly radially; they correspond with the first and second cycles of tentacles, and sometimes with the lower orders. In large specimens, the tubercles may extend in great numbers over nearly the whole of the disc, even as far as the peristome, and vary considerably in number, size, and distance apart in each row. Before the peristome is reached they become more closely and irregularly arranged, and seem to correspond with all the mesenterial spaces (Pl. x., fig. 1).



Water was freely emitted through the tubercles when the animal was compressed in collecting, though it may be doubted if this occurs naturally. The peristome is slightly raised, and the gonidial grooves are well-marked, the two lips being thicker and lighter than the rest of the stomodæal walls.

The polyps possess very limited powers of retraction; the disc and tentacles are not infolded.

The colours are very variable, partly dependent upon the age of the specimens and whether the tentacles are smooth or bear thickened bands—but all gradations can be traced in an abundant series. The prevailing disc colours are brown and green, often iridescent, with opaque white spots and blotches; those of the column are scarlet and crimson on a white or cream ground.

The base is white, or may exhibit bright, radiating scarlet bands. The column is usually cream white, with irregular, longitudinal patches of scarlet; the verrucæ display a very pronounced deep crimson centre. The column-wall is light grey in young specimens, darker above. In these small forms the tentacles are also greyish, the thickenings appearing as transverse white bands. The concave, outer aspect of the tentacles is white, and a V-shaped white patch, with the angle open, occurs at the base. In some the thickenings are of the same brown colour as the tentacle itself. The smooth tentacles are brown or reddish brown, with light crimson tips, and three longitudinal lighter lines traverse the whole length.

The disc bears white, green, and blackish patches; a black or brown radial patch occurs at the inner aspect of the base of each of the primary tentacles, and two towards the base of the four next cycles. The peristome is usually iridescent green.

The dimensions are likewise very variable according to age. Many young specimens were collected, in which the length of the column was only 1.1 cm., and the diameter, 0.8 cm. When extended the disc is about 5.5 cm. across in large examples, but may be as much as 9 cm.; the length of the column is generally about 6 cm.; the diameter across the middle, 1.7 cm., and across the base, 2.5. The innermost tentacles measure 0.7 cm. in length.

The figure of this species given by Professor M Murrich (1889, Pl. II., fig. 1), represents the more usual appearances of the Jamaican specimens, and I have not considered it necessary to add another. The marginal tentacles should, however, be compared with that on Pl. x. of the present paper.

#### ANATOMY AND HISTOLOGY.

The ectoderm of the base is a very deep, columnar epithelium, much broader than either of the two other layers, and, in sections, is thrown into strong folds, partly followed by the mesogloea. Long, narrow, supporting cells are

the chief constituents, but a few gland cells are also intermingled, though not by any means so thickly as in the ectoderm of the column-wall. Towards the mesogloea a fibrillar layer is very clearly displayed. No ectodermal muscle is present, or is only of the weakest character. The mesogloea is typical of its condition throughout the polyp, being very fibrous, and containing numerous cellular constituents. To its shrinkage is perhaps due, in some degree, the fine display of both the ectodermal and endodermal fibrillar layers which occur throughout all the polyps sectionized.

As shown in the ectoderm of Pl. xi., fig. 1, very fine fibrils, arranged in an almost parallel manner, extend from the delicate muscular layer, and afterwards unite to form an extremely thin layer. This latter usually appears as if made up of very delicate interlacing fibrillæ; and on its outer side another series of fibrils, irregularly arranged, are given off, and are connected with the cells of the ectoderm. For the sake of distinction I restrict the term nerve layer to the delicate, interlacing layer, and speak of that between it and the muscle layer as the fibrillar layer. Sometimes, as is represented in the endoderm of the same figure, the fibrils extending from the muscle fibres do not unite to form a definite nerve layer, but interlace and are reticular in section. What appear to be Ganglionic cells are distributed among the fibrillæ. Appearances similar to the above are also represented in the section through a portion of the tentacle and also of the gonidial groove of *Homostichanthus anemone* (Pl. xv., fig. 1; Pl. xiv., fig. 2), and can be made out in sections of most species.

The endoderm of the base contains many zooxanthellæ, which, along with the cell protoplasm and nuclei, are mostly concentrated towards the free border of the layer. A well-marked fibrillar stratum extends for some distance from the endodermal muscle, and the latter is arranged on fine mesogloéal plaitings.

The column-wall throughout is of only medium thickness, and becomes thinner towards the apex; the mesogloea is nowhere much broader than the ectoderm or endoderm. The ectoderm is very deeply ridged in places, the elevations being partly followed by long processes of the mesogloea, often branching, and much longer than the whole thickness of the wall. The supporting cells are scarcely so long as at the base; but unicellular glands, some with granular contents and others quite clear, are abundant. Maceration preparations reveal the presence of numbers of small nematocysts. A very weak longitudinal ectodermal muscle is present, and a nervous layer is readily distinguishable in places. The endoderm is a deep layer containing zooxanthellæ; its constituent cells are considerably elevated between the mesenteries where these are closely arranged. Throughout the column the endodermal circular musculature is developed with exceptional uniformity, the mesogloea being finely plaited for its support, and a nervous layer is clearly seen in some parts (Pl. xi., fig. 1).

As already ascertained by M<sup>c</sup>Murrich, there is no special concentration of the endodermal muscle to form a sphincter; indeed, the musculature, if anything, becomes more feeble towards the apex.

The verrucæ are readily distinguished from the rest of the column by the absence of gland cells from the ectoderm, and by the nuclear zone being broader and staining more deeply.

Sections through the acrorhagi reveal a thinner wall, an absence of gland cells, and small nematocysts.

In the tentacles, both the ectodermal and endodermal muscles are well-developed on mesogloæal plaitings. The nematocysts in the former layer are extremely small, and, in both, the fibrillar layer extends for some distance from the mesogloæa. Zooxanthellæ are abundant in the inner layer. Where the sections include one of the tentacular swellings, the enlargement is seen to be due to a slight increase in thickness of the endoderm, but more especially of the mesogloæa.

The disc is much like the tentacles in structure, but thinner-walled, and fewer nematocysts occur in the ectoderm. The mesogloæa is thrown into elongated branching folds to serve as an additional support to the endodermal circular muscle.

Sections through the wart-like projections reveal slight, hollow upgrowths of the disc; the mesogloæa and musculature become so attenuated as to be with difficulty recognizable, and the ectoderm is thinner than elsewhere, but apparently does not exhibit any new structural elements. Like M<sup>c</sup>Murrich, I have been unable to determine if the tubercles are actually perforated, but the delicacy attained by both the mesogloæa and ectoderm at the apex is an indication that the production of a temporary opening by any pressure from within would be a matter of very little difficulty. It has already been noted that water may be emitted in the living condition. M<sup>c</sup>Murrich (1889, pl. iv., fig. 11) gives a figure of a section through one of the disc tentacles.

The stomodæum is very elongate and oval-shaped in transverse sections, and extends almost across the coelenteron, the pair of directives at each extremity being much shorter than the lateral complete mesenteries. In longitudinal sections, the stomodæum is comparatively short. Its walls are thin, and the ectoderm is thrown into irregular vertical folds, partly followed by the mesogloæa. The gonidial grooves are clearly indicated at each end, their walls unfolded, and not much thicker than the rest of the stomodæum. At each end the groove is prolonged for some distance below the lateral walls, the directives remaining attached all the way. All the other mesenteries, however, are very deeply concave along their free edge towards their attachment to the stomodæal wall, so that in transverse sections through this region a short portion of each mesentery

still remains attached to the stomodæum and hangs freely from it, while the longer portion is connected with the column-wall and appears as a free mesentery. Histologically, the stomodæal ectoderm consists mainly of ciliated supporting cells and long, narrow gland cells with finely granular contents; the nuclei of the former give rise to a brightly-staining middle zone. A weak longitudinal ectodermal musculature and a nervous layer are distinctly recognizable. Nematocysts cannot be detected in sections. The mesoglæa is folded on its endodermal border for the support of the weak endodermal muscle. The endoderm itself is an extremely narrow layer, displaying nerve fibrillæ.

In polyps small enough to be sectionized as a whole, twelve pairs of perfect mesenteries are present, of which two pairs are directives. These constitute the first and second cycles; and it is usually found that the members of the second cycle become free in advance of the others; the directives, as already stated, extend much below the others, retaining their attachment to the prolonged gonidial grooves. A third cycle of twelve mesenteries alternates with the complete members, and extends some distance within the cœlenteron, while a fourth cycle of twenty-four mesenteries extends but a little beyond the column-wall. In dissections of large polyps, a fifth cycle of forty-eight pairs of mesenteries occurred, the fourth cycle now stretching well within the cœlenteron, and the third cycle becomes connected with the stomodæum for some distance. Trilobed mesenterial filaments are borne by the members of the first three cycles. The mesenteries are exceptionally narrow, and, as a whole, occupy but a small proportion of the cœlenteron. The perial stomata are very pronounced, but the marginal stomata are small and not readily distinguished.

The retractor muscle is arranged on very narrow, bifurcating, mesoglæal processes and gives rise to a thickened band, distally situated at a considerable distance from the column-wall (Pl. XI., fig. 1), but nearer proximally. In sections it commences as a rounded or acute enlargement, and centrally diminishes gradually. The musculature beyond the region of the retractor is very feeble, except towards the origin of the mesentery in the column-wall, where, in the region below the stomodæum, a parieto-basilar muscle is well developed, and a strongly plaited pennon is present. The endodermal muscle is continued between the mesoglæa at the base of the mesentery, and that of the column-wall. The retractor is developed on all the cycles of mesenteries except the lowest; while in the proximal region a muscular layer is continued all round the smallest mesenteries, the mesoglæa being folded. The oblique musculature is very feeble.

The mesenterial epithelium is narrow, except towards the origin of the mesenteries, where it broadens, and what appears to be nerve fibrillæ become very obvious; the cell contents are here aggregated mostly peripherally (Pl. XI., fig. 1).

For a short distance both above and below the inner termination of the

stomodæum the mesenterial filaments are trilobed in transverse section, the middle lobe bearing the glandular streak or Nesselldrüsenstreif, and each lateral lobe a ciliated streak or Flimmerstreif (Pl. XI., fig. 2). I have elsewhere (1898, p. 644) suggested that it is scarcely correct to regard the term middle lobe as synonymous with the two first terms, nor the lateral lobes as synonymous with the second terms. The lobes are very complex in their structure, and different regions in each are marked out by very distinct histological characters.

In *Phymanthus*, as in practically all compound filaments, the apical region of the middle lobe can be sharply distinguished histologically from its lateral regions. The apex stains more deeply, owing to the presence of numerous ciliated supporting cells with oval nuclei, and usually contains intermingled granular gland cells and nematocysts. Beyond this the histological elements are not so closely aggregated; the cell nuclei are rounded, the ciliated layer is not so strong, nematocysts are absent, and zooxanthellæ usually occur. With very little alteration this tissue is continued for a short distance on to the lateral lobes, where it becomes replaced by another, which is at once distinguished from all other structures of the Actinian polyp by the brightly-staining, homogeneous character of its cell constituents. Both in sections and in macerations, these are seen to consist of ciliated supporting cells, the oval nucleus being arranged at different heights in the various cells, so as to produce a nucleated zone, extending practically across the thickness of the layer; neither gland cells nor nematocysts are ever mingled with the supporting cells, and the ciliation usually persists in preserved specimens, even when absent from all other regions of the polyp.

The hinder region of the filament, where it is connected with the mesentery, displays still another histological modification. From the lateral mesogloæal axis a fibrillar reticulation is developed, and extends nearly to the periphery of the layer, but there becomes more like the ordinary endoderm in character, possessing nuclei, gland cells, and, usually, zooxanthellæ. As this passes on to the mesentery, it becomes indistinguishable from the mesenterial endoderm. The mesogloæa of the axes supporting the middle and lateral lobes also becomes modified. It is broader than the mesenterial mesogloæa immediately behind, and oval or stellate cells are numerous developed, so that the whole structure stains very deeply, and stands out very prominently from the surrounding tissue. Similar details are afforded by the filaments of nearly all Actiniaria which possess a trifid mesogloæal axis (cf. Pl. XI., fig. 2 and Pl. xv., fig. 4, the latter a zoanthid).

It is usual to recognize in the trilobed mesenterial filament only the glandular streak and the ciliated streaks, and these terms have been generally employed as synonymous with the middle and lateral lobes, respectively. It seems desirable, however, to distinguish more closely the various regions exhibiting a different histological structure, and presumably performing a different function. The term

*glandular streak*, and its German equivalents, Drüsenstreif or Nesseldrüsenstreif, I would restrict to the tissue at the apical region of the middle lobe; *ciliated streak*, or Flimmerstreifen, to the deeply-staining, strongly-ciliated region of the lateral lobes; *intermediate streak*, to the region on each side, partly developed on both the middle and lateral lobes, and separating the two zones already indicated; *reticular streak*, to the tissue along the basal region of the filament, the term most nearly expressing its character in microscopic sections.

When the ciliated streak disappears proximally, and the filament becomes what is known as simple, a trilobed outline in transverse section is nevertheless often preserved. Here the lateral enlargements, however, bear no relation except that of position, with the true trilobed filament. They are of the same significance as those to be described in connexion with *Corynaectis myrcia* (Pl. xv., fig. 3), that is, each is simply a swelling of the ordinary mesenterial endoderm, there being little histological modification and no special supporting mesogleal axis.

Histologically the whole of the terminal lobe in the simple filament appears to correspond with the apical tissue of the middle lobe in the trifoliate filament, that is, with the glandular streak as here restricted. Nematocysts generally become more numerous proximally, and the filaments are branched along with the free edge of the mesentery.

A peculiarity connected with the glandular streak in the present species is that the actual apex in some cases becomes deeply grooved, resembling that figured by the Hertwigs (1879, pl. v., fig. 14) for one of the lower mesenteries of *Sagartia parasitica*, and recalling the condition in the so-called "ectodermal filaments" of the Alcyonaria.

Ripe ova were present on mesenteries of the higher orders, in one specimen sectionized. McMurrich found all the mesenteries, even the directives, to be gonophoric. His Bahaman specimens were also hermaphrodite, but none of the Jamaican examples show such a combination of gonads, nor was this the case with the two species described by Kwietniewski (1898).

The species is found in considerable numbers, associated with *Asteractis*, in the crevices of coral rock, or on stones embedded in the coral sand, in the shallow waters on the south east-shore of Drunkenman Cay, outside Kingston Harbour.

They are seen with only the disc exposed, the overhanging portion of the column resting on the surface of the sand, while the base may be buried to a considerable depth.

The mottled, greyish colours of the younger forms harmonize with their surroundings, but the brighter colours of the adults offer a great contrast. It is among the abundance of specimens occurring at Drunkenman Cay, that the forms with smooth tentacles are to be procured. Large examples of the species

are also met with at Port Antonio. All these possess the thickenings on the tentacles, and the disc tubercles are strongly developed.

It is evidently a common West Indian anemone, having been recorded from the following localities: attached to stones on the sand-banks of the island of Barbados (Lesueur); St. Thomas and Barbados (Duchassaing and Michelotti); usually fastened to blocks of coral rock in shallow water, Bahamas (M<sup>c</sup>Murrich).

Professor M<sup>c</sup>Murrich has already described the form in considerable detail. The salient features in which the Jamaican examples differ are the variability in colour, and the entire absence, in some instances, of the thickenings on the tentacles. The first mentioned character is especially noticeable in young specimens, these being largely a mottled grey and black, in strong contrast with the more brilliant colours of the large examples. *P. mucosus*, from the Australian seas, also displays somewhat similar colour variations.

The presence or absence of the thickenings on the tentacles would be worthy of at least specific distinction were it not that every gradation can be traced between the two extremes.

In respect to the tubercles on the tentacles the West Indian representative of the genus should be compared with the several species known from the Indo-Pacific region. The former never shows anything beyond simple or bilobed thickenings on the oro-lateral aspect of its tentacles, while the tentacles on *P. loligo*, Ehr., from the Red Sea, may bear pedunculate and branched outgrowths; *P. mucosus*, H. & S., and *P. levis*, Kwiet., also carry slightly dendritic appendages.

#### Family.—RHODACTIDÆ, Andres.

*Phyllactinidæ* (pars), . . Klunzinger, 1877.

*Rhodactidæ*, . . . . Andres, 1883; (pars) M<sup>c</sup>Murrich, 1889; Haddon, 1898.

Stichodactylinæ, in which the tentacles are of two forms, marginal tentacles of the ordinary form, arranged in a single cycle; inner tentacles lobed or tuberculi-form and irregularly arranged.

Under this family Professor M<sup>c</sup>Murrich includes the two West Indian species, *Actinotryx* (*Rhodactis*) *Sancti-Thomæ* and *Ricordea florida*. Owing to more recent researches, it seems to me imperative to remove *Ricordea* from this association and to assign it a place among the Discosomidæ, a position already hinted at both by MM. Duchassaing and Michelotti (1866, p. 122), and by Professor Verrill (1869, p. 462).

The form and arrangement of the tentacles must undoubtedly be the determining consideration in the classification of the order; and in the two species mentioned, these bear no close relation one to the other. *Ricordea* agrees with the chief characteristic of the Discosomidæ in possessing tentacles all of one form and

covering nearly the whole of the disc, while there is a marked difference, both in form and histology, between the marginal and discal tentacles in *Actinotryx*.

In important anatomical details, such as the deep stomodæal folds, absence of gonidial grooves, and ciliated streak, *Actinotryx* and *Ricordea* are related; but, excepting perhaps the last mentioned, evidently not much reliance can yet be placed upon these for indicating broader relationships.

It is a question of choosing between external characters, and internal anatomy and histology as the chief factors of relationship. In the order *Stichodactylinae*, at any rate, I am of opinion that the best results will be attained by giving the greater prominence to the arrangement of the tentacles among the former. The frequent multi-oral condition of the disc occurring in both, must assuredly be looked upon as a specific peculiarity.

Haddon (1898, p. 477) includes the four genera, *Rhodactis*, *Actinotryx*, *Ricordea*, and *Heteranthus* in the family. The second genus was instituted by Duchassaing and Michelotti (1860, p. 45) for a West Indian form, which later was regarded by M<sup>c</sup>Murrich as allied to the *Rhodactis rhodostoma* of the Red Sea, and was therefore transferred to that genus. From details of this species supplied by Dr. Carlgren, Haddon (p. 477) considers that the two should remain as distinct genera, and this is the conclusion I have followed.

Genus.—**ACTINOTRYX**, Duchassaing & Michelotti.

*Actinotryx*, . . . Duchassaing and Michelotti, 1860; Andres (*Actinothrix*),  
1883 (pars); Haddon, 1898.

*Rhodactis*, . . . M<sup>c</sup>Murrich, 1889.

*Rhodactidæ*, in which the column is smooth. Marginal tentacles short, in two or three series, but forming only one cycle; inner tentacles dendritic or lobed, partly separated into a middle discal group and a perioral group. Sphincter muscle feeble or absent. An ectodermal muscular layer on the column-wall and stomodæum. Stomodæum deeply furrowed. No gonidial grooves. Mesenterial filaments devoid of ciliated streak.

The history of the genus has just been given under the discussion on the family.

**Actinotryx Sancti-Thomæ**, Duch. & Mich.

(Pl. x., figs. 3-6; Pl. xi., figs. 3, 4; Pl. xii., fig. 3).

*Actinotryx Sancti-Thomæ*, Duchassaing & Michelotti, 1860, p. 45, pl. vii.,  
fig. 2; 1866, p. 35.

*Actinothrix Sancti-Thomæ*, Andres, 1883, p. 509.

*Rhodactis Sancti-Thomæ*, M<sup>c</sup>Murrich, 1889, p. 42, pl. i., fig. 9, pl. iv., figs. 2, 3.



The base is very spreading, irregular in outline, and firmly fixed to coral rock, adapting itself to the irregularities of the surface; in diameter it is larger than the column. A brownish, cuticular layer occurs between the ectoderm of the base and the surface of attachment, and may either be detached with the polyp or remain adhering to the rock. The internal, radiating mesenterial lines are clearly indicated through the thin basal-wall.

The column is short, thin-walled, and semi-transparent, the mesenterial lines showing through; the surface is smooth, and thrown into delicate longitudinal ridges and furrows, and occasionally transverse wrinklins are indicated. The limbus is spreading and irregular, and the polyps are generally constricted a little above the middle. The upper region of the column and the disc usually overhang so as to hide the parts below. Individual polyps are generally oval in outline in transverse sections.

A single cycle of very short tentacles occurs at the apex of the column or margin of the disc, a longer tentacle alternating with a short one, or there may be two or three of the latter between two longer ones. Much irregularity occurs in this respect. In shape the tentacles may be shortly acuminate, or cylindrical and rounded at the tips. A small, nearly horizontal, tentaculiform outgrowth projects from near the base of many of the larger tentacles, and, occasionally, from the middle tentacle of an alternating three.

The disc is divisible into two regions: a peripheral, naked area, limited outwardly by the marginal cycle of tentacles; and a larger, inner area bearing the branching outgrowths described as tentacles. The peripheral portion of the disc is very thin, and sometimes stands as a distinct parapet or collar around the inner part; at other times it is entirely reflexed (Pl. x., fig. 3). The discal tentacles are very short, thick, columnar outgrowths which divide towards the apex into numerous—6 to 12—small, tubercular, finger-shaped, or pointed processes. A few, irregularly arranged examples may occur near the mouth, or they may be practically absent from this region. The organs are capable of assuming the flaccid condition, or one of distension, independently of one another. They may be distributed over the whole disc except near the margin, but are always less numerous centrally. The distinction between the discal and the perioral series is not always apparent. Usually the tentacles appear irregularly disposed, but occasionally an arrangement in cycles, or, more often, in radial series, is evident. It is doubtful if more than two or three ever communicate with the same mesenterial chamber (Pl. x., figs. 3-6).

In the living condition the disc usually overhangs so as to hide the base and column; but the peripheral, naked portion of the disc may be vertically elevated as much as 4 mm. above the central part. In retraction the capitular part of the column closes over the rest of the disc as a thin, radiately marked, semi-trans-

parent membrane, and all the marginal tentacles come together in the centre and close up the aperture.

The peristome is considerably elevated and usually elongated; like the rest of the disc it bears tuberculate bodies, which are here usually a little smaller. The mouth is circular in small forms, elongated in larger. The stomodæal wall is thrown into numerous, deep, much flattened folds, and is capable of considerable eversion. It is very sharply marked off from the disc. Twenty folds were counted in a very small specimen, and over thirty occurred in another; true gonidial grooves do not occur (aglyphic).

Polyps are occasionally come upon in which the disc bears two or more distinct mouths, without any indication of longitudinal fission.

The coloration varies much in detail in different polyps. The column-wall is light or dark brown, usually darker above, but lighter again towards the apex, the latter often showing an iridescent green tinge. The disc is an iridescent green, with brown, radiating lines separating it into narrow, radial areas; or, the general surface of the disc may be brown, and the radiating lines iridescent green.

Some of the radial bands may be nearly opaque white. The larger marginal tentacles are a faint blue below, brownish or rose-coloured distally; the smaller tentacles are brown. The disc tentacles are brown and iridescent green, or may be a deep blue purple. The stomodæal-walls are white.

The dimensions are very variable. The base may be 2.5 cm. across; the column 1.4 cm. in diameter, and 1 to 2 cm. high. The length of the larger marginal tentacles is 0.2 cm. One specimen was obtained with a disc 5.4 cm. in length, and length of mouth, 1.3 cm.

#### ANATOMY AND HISTOLOGY.

The ectoderm of the base is formed of high supporting cells, along with a few mucous cells. In sections the nuclei of the former give rise to a distinct narrow zone, situated a little nearer the mesogloea. A very thick, brown, cuticular membrane, which readily strips off, is still present in some examples, and is continued for a short distance up the column. The mesogloea, as is the case throughout the whole polyp, is very thin, and rather large ovate cells are sparsely scattered through it; a very weak musculature appears both on its ectodermal and endodermal borders. The endoderm is much narrower than the ectoderm, and is well supplied with gland cells, but devoid of zooxanthellæ.

The ectoderm of the column-wall is a high layer, and crowded with clear, unicellular, mucous glands, so that an outer zone appears colourless, the contents of the glands not staining. The cells are extremely delicate, and in sections are nearly always collapsed or shrunk; indeed the tissues as a whole are less resistant

than any other form I have studied. This is probably a result of the excessive abundance of glandular cells in both ectoderm and endoderm. The nuclei of the ectodermal cells of the column-wall become aggregated towards the mesogloea, and the muscular layer is distinctly recognizable where much shrinkage has not taken place. No nematocysts are present.

The mesogloea is thin, but distally is formed into irregular plaits for the support of the endodermal muscle. On its ectodermal aspect it is thrown into the deep ridges with wide intervening furrows, already noticed among the external characters.

The endoderm bears numerous zooxanthellæ, especially above, and also scattered nematocysts. The cells are long and narrow, and the nuclei are arranged in a very narrow zone. The endodermal musculature commences a little above the base as a very thin, smooth layer; distally, however, it is more developed on slightly branching mesogloéal plaitings, being most concentrated just below the marginal tentacles (Pl. XL, fig. 3). This exaggeration should probably be regarded as a diffuse endodermal sphincter muscle, continuous on the one hand with that of the column-wall, and on the other with that over the smooth naked portion of the disc. It is obvious that no very precise distinction can be drawn in the early stages of development between a strong endodermal muscle and a concentration which may be spoken of as a diffuse endodermal sphincter; and, even in the same species, there is undoubtedly much variation in the extent of the mesogloéal foldings, according to the degree of retraction in which the polyp happened to be preserved.

The musculature appears to be a little better developed than was found by Prof. M<sup>c</sup>Murich in his Bahaman specimens. In these the circular muscle of the column is described as being throughout exceedingly feebly developed. The extent of development here given was met with in two examples sectionized; but in a third the concentration of the muscle fibres and folding of the mesogloea was observable to a much less degree, the condition evidently being about the same as that found by M<sup>c</sup>Murich. The two first specimens were somewhat infolded in preservation, while the other was extended.

Professor M<sup>c</sup>Murich (p. 44) notes as a peculiar feature of the ectoderm of the disc, marginal tentacles, and disc tentacles that nematocysts are entirely absent. I have made a careful investigation of this exceptional condition, and, so far as regards the results obtainable from sections, my experience agrees with that of M<sup>c</sup>Murich, but on submitting the marginal tentacles to maceration I find ectodermal nematocysts very abundant at the tips. They are elongated, rounded at each end, and the spiral thread is not very distinct, while the interior presents a granular appearance. The endoderm also contains many nematocysts, but they are of a totally different character. Maceration of the ectoderm of the disc

tentacles does not, however, yield any stinging cells. Gland cells are not developed in the marginal tentacles to the same extent as in the column-wall. The endodermal muscle is continued into the tentacles only as a very thin layer, the mesogloea not being plaited; but, in the naked region of the disc, directly from the base of the tentacles, it is again strongly developed on mesogloéal plaitings, and extends the whole width of the naked area, practically disappearing again as the disc tentacles are reached. The ectoderm of the disc, though still containing gland cells, is narrow, but the endoderm becomes enormously thickened, and presents the appearance of an extremely loose vesicular tissue. In the disc tentacles, the ectoderm and mesogloea are thin, but the large cavity is almost filled with the loose endodermal tissue, among which are numerous zooxanthellæ and medium-sized ovate nematocysts, with a loose thread thrown into four or five loops; an extraordinarily large stinging cyst is met with here and there. These latter are enormous, horn-coloured cysts when mature, and bear tubercular or spine-like outgrowths. They are by far the largest met with in any anemone described from this region (Pl. XI, fig. 4).

The constituent cells of the endoderm readily separate on maceration. The supporting cells are of the usual type, but longer, and the free extremity is ciliated; the small nucleus occurs about the middle of the length. In places where one or more zooxanthellæ are enclosed the cell is greatly swollen.

The stomodæum is round in transverse section, but short vertically, and its walls are very deeply folded in the latter direction. These foldings which are so marked a feature amongst the external characters are seen on anatomical examination to be elevations of the ectoderm followed by the mesogloea, but not by the endoderm. They often branch even more than is shown in M<sup>c</sup>Murrich's figure (1889, Pl. iv., fig. 3). The ectoderm presents the usual characters, having a clear peripheral zone ciliated on the outside, a broad middle zone of oval deeply-staining nuclei, and a narrow fibrillar zone. Nematocysts of various sizes are present, including the large, colourless cysts with a spiral thread. A feeble longitudinal musculature can be detected. The endoderm is much like that of the column-wall, but deeper, and fewer zooxanthellæ and no nematocysts occur. The endodermal muscle is clearly distinguished, and rather strong, arranged on small mesogloéal plaitings.

As already remarked by Prof. M<sup>c</sup>Murrich the arrangement of the mesenteries is difficult to determine, and appears very irregular in the alternation of perfect and imperfect pairs, as does also the number of pairs. In addition to the complete mesenteries an imperfect series is well developed, extending some distance within the cœlenteron, and, in certain regions, a second incomplete order is also formed. The pairs are closely situated at about equal distances all the way round, the endocœles and exocœles being of nearly equal width; the endoderm of the column-

wall within the mesenterial spaces is sometimes much elevated. The number of mesenteries is considerable, one small specimen possessed fourteen complete pairs, and another eighteen. The mesogläea is very thin, and the vertical retractor muscles are extremely weak, so as to render it almost impossible to determine the directives. I have been able to definitely ascertain the presence of the latter in only one instance, but others may occur. The parieto-basilar muscle, though weak, is clearly distinguishable on each side. The endoderm is a thick, highly glandular layer, and medium-sized stinging cysts are abundant in places. In some instances the coelenteron appears filled with the mucus extended from the endoderm cells.

The mesenterial filaments consist only of the middle glandular streak or Nesseldrüsenstreif, the lateral ciliated streak or Flimmerstreifen being absent (Pl. XI., fig. 4). They are seen to originate in direct continuity with the ectoderm of the stomodæum. At first, owing to the strongly folded condition of the stomodæal ectoderm the mesenterial filament is irregular, or rather the appearance is presented as if a portion of the terminal region of the stomodæum were still connected with the free edge of each mesentery. It is only a little below the stomodæum that the ordinary rounded appearance is assumed, but the Nesseldrüsenstreif is never clearly marked off from the mesenterial epithelium (Pl. XI., fig. 4). The nematocysts in the upper region are elongated and narrow, but below they are much larger, oval, and strongly spinous. Different stages in the growth of the large tuberculated nematocysts can be distinguished, the contents of the younger staining deeply with carmine. The mature individuals present a peculiar appearance when a group is cut through transversely. Irregular spine-like projections extend all the way round the thick horn-coloured wall, the interior appears filled with some coagulated substance, and here and there a cut end of the thread is indicated. The spiral threads themselves are finely and regularly spirally marked. Towards the free end of the mesenteries in the lower regions the endoderm is often loaded with zooxanthellæ.

Of several specimens sectionized, only one contained reproductive organs, spermaria apparently in a dehiscing condition (Pl. XII., fig. 3). The reproductive cells are found in the interior of the mesogläea, and in escaping break through the endodermal tissue. They occur in only a few of the mesenteries.

In three polyps dissected in the living condition, a few embryos were found. They are large, dark-green, ovoid bodies, slightly narrower at one end, and about 1 mm. in length. On cutting open the animal, they escaped freely into the water.

Prof. M<sup>c</sup>Murrich (1891, p. 303) found that the polyps retain the embryos in the interior of the body until they are furnished with two or four perfect mesenteries. During the month of September I observed examples in process of parturition. The disc and upper part of the column were almost entirely infolded,

and then rapidly extended, several opaque, yellowish-green embryos being extruded each time.

The species is found rather plentifully around the coral reefs of most of the Port Royal Cays, and very large examples were obtained around Maiden Cay, and also at Port Antonio. It was met with at New Providence, Bahamas, by Professor McMurrich, while Duchassaing and Michelotti collected their types at St. Thomas; so that it probably occurs on the coral reefs throughout the Antillean area.

The polyps occur in water of from two to three fathoms, firmly attached to coral rock, and usually in company with living coral. Associations of several scores may occur, giving a carpet-like appearance to the sea-floor.

The body-wall and disc are very delicate; after a little rough handling in collecting the mesenterial filaments readily protrude, especially through the disc, and an abundance of mucus is also given out. Such a protrusion of the mesenterial filaments through any part of the body-wall is rarely met with in *Actiniæ*, but is a usual occurrence among the corals.

The asexual reproduction by intracalyceinal fission is the same as in *Ricordia florida*, except that one does not so often meet with individuals showing the multi-oral condition, fission and separation evidently taking place more readily. A very elongated example was procured having a small second mouth at one end, round which the disc tentacles had become closely aggregated, but the column-wall showed no sign of division.

The multiple arrangement presented by the tentaculate areas in *Actinotryx bryoides*, described by Professor Haddon from Torres Straits, is in marked contrast with their irregular disposition in the West Indian species, as also the seven or eight smaller peripheral tentacles alternating between two larger. The "one or two short knob-like tentacles on most of the crenulations of the parapet" are perhaps comparable with the horizontal outgrowths on some of the marginal tentacles in the present form.

Sub-order.—HOMODACTYLINÆ, n. s.-o.

Family.—DISCOSOMIDÆ, Klunzinger.

*Discostomine*, . . . Verrill, 1869.

*Discosomide*, : . . (pars), Klunzinger, 1877.

*Discosomide*, . . . Andres, 1883; McMurrich, 1889, 1893; Kwietniewski, 1897, 1898; Haddon, 1898.

Stichodactylinæ, in which the column-wall is smooth or provided with verrucæ towards its upper portion. Oral disc usually of large size and lobed. Tentacles numerous, and covering the greater portion of the surface of the disc; all short

and of one form; either finger-shaped, knobbed, pointed, or vesicle-like; a peripheral series, arranged in cycles, is usually distinguishable from an inner series, arranged only in radial rows; one or more rows may communicate with the same mesenteric space. Mesenteries very numerous, many of which are perfect. Sphincter muscle present or absent.

As the Actiniaria of tropical regions are more studied, the genera embraced under this family become more and more numerous. In addition to the type genus *Discosoma*, the genera *Radianthus*, *Stichodactis*, and *Helianthopsis*, all erected by Kwietniewski (1898), are anatomically known; Haddon (1898) adds *Discosomoides* and *Stoichactis*; while in the present communication I increase the family by including within it the genera *Actinoporus*, *Homostichanthus*, and *Ricordea*.

From these, and from the definition given above, it will be seen that the family includes a very heterogeneous assemblage of forms, corresponding in this respect with the *Sagartidæ* among the *Actiniæ*. The only constant feature appears to be that the tentacles are all of the same form in any one species, and cover the greater portion of the disc; but apparently in no two genera are the peripheral and the inner tentacles similarly related. It will probably be found advisable later to separate as sub-families forms in which only one row of tentacles communicates with a mesenteric chamber from those in which, as in *Actinoporus*, two or more rows may originate from the same mesenteric chamber.

Following the work of M<sup>c</sup>Murich, Simon, and Kwietniewski upon various forms, Professor Haddon (1898, p. 469), in his recent paper, endeavours to introduce some order into the group, but significantly remarks: "This family will require a good deal of working at before it can be satisfactorily classified." He does not, however, attach that importance to the relationships of the peripheral to the inner tentacles, and of both to the mesenteric chambers, from which I am hopeful that much assistance can be obtained in arranging the numerous members of the family.

Genus.—**RICORDEA**, Duchassaing and Michelotti.

*Ricordea*, . . . Duchassaing and Michelotti, 1860; M<sup>c</sup>Murich, 1896;  
Haddon, 1898.

*Heteranthus*, . . . (Klunzinger, 1877), M<sup>c</sup>Murich, 1889.

*Discosomidæ*, in which the marginal tentacles are small, dicyclic, finger-shaped or slightly knobbed; inner tentacles a little smaller, of the same form, in single radial rows. Sphincter muscle absent. No gonidial grooves. An ectodermal longitudinal muscular layer on the column-wall, and on the stomodæal wall. Numerous perfect mesenteries; mesenteric filaments devoid of ciliated streak.

My reasons for transferring this genus from the family Rhodactidæ, where it has usually been placed, to the family Discosomidæ, are given under the discussion on the former family.

Succinctly, the history of the genus is as follows: MM. Duchassaing and Michelotti (1860) first established *Ricordea* for the species about to be noticed; in 1877, Klunzinger erected the genus *Heteranthus* for a very similar form, *H. verruculatus*, from the Red Sea; Andres associated this latter species with the genus *Actinotrix*, which Duchassaing and Michelotti had erected for the form here described as *Actinotryx Sancti-Thomæ*, placing *Ricordea florida* among the "species incertæ sedis." M<sup>c</sup>Murich (1889), considering Duchassaing and Michelotti's definition of their genus *Ricordea* to be only specific, not generic, in character, disregarded it in favour of Klunzinger's *Heteranthus*; in a later paper M<sup>c</sup>Murich (1896) returns to the original term *Ricordea*.

As at present known the genus includes with certainty only the one species, *R. florida*. The precise position of *Heteranthus verruculatus* cannot be established until an anatomical examination of it has been made. Haddon (1898, p. 481) suggests that two or three other species, described under different generic terms, may also be included along with *R. florida*.

*Ricordea* is undoubtedly closely allied to the two genera *Discosomoides* and *Discosoma*, as these are defined by Haddon (p. 470) from Simon's researches. The three agree in having a smooth column-wall, tuberculiform or papilliform tentacles, no gonidial grooves, numerous perfect mesenteries, and sphincter muscle absent or weak. Both *R. florida* and *D. nummiforme* are, in addition, characterized by the clearness of their mesogloea, and the exceptional structure of their mesenterial filaments.

***Ricordea florida*.**—(Pl. x., fig. 7; Pl. xi., figs. 5, 6; Pl. xii., figs. 1, 2; Pl. xiii., fig. 1), Duchassaing and Michelotti.

*Ricordea florida*, . . . Duchassaing and Michelotti, 1860, p. 42, pl. vi., fig. 11; 1866, p. 122; Andres, 1883, p. 572; M<sup>c</sup>Murich, 1896, p. 188.

*Heteranthus floridus*, . . . M<sup>c</sup>Murich, 1889, p. 47, pl. i., fig. 10; pl. iv., figs. 4–5.

The base is usually smaller in diameter than the column, and adheres so closely to the irregular surfaces of coral rock as to render almost impossible the removal of the polyp without injury or the separation of fragments of the rock.

The column is short and variously outlined. Simple forms are cylindrical, but compound examples are elongated laterally and sinuous above; the limbus is generally irregular, and often of less diameter than the more distal part of the



column. The column-wall is smooth and delicate, and the insertion of the mesenteries shows through. The wall is finely ridged in the living condition; while, in preserved specimens, it is thrown into rather deep, close, zigzag, vertical striæ, but no verrucæ occur.

The tentacles are short, knobbed or rounded at the apex, and arranged in two series: a marginal cyclic group, and an inner radiating group. The former are dicyclic and entacmæous; the latter extend for various distances from near the margin towards the centre, diminishing slightly in size centripetally. In places, a distinct serial arrangement of the radial tentacles is exhibited, those of the first order reaching as far as the peristome, the second and alternating order a little shorter, and a third and fourth still more so. The shortest series contains only two or three tentacles in each row. This regular and evidently normal arrangement is departed from in other parts of the disc. About 60 rows were counted in one specimen, but the number varies with the size of the polyp. Each marginal tentacle consists of a short stalk narrowing a little above, and terminating bluntly or in a slight knob. Professor M<sup>c</sup>Murich describes and figures the marginal tentacles of the Bahaman specimens as conical.

The inner tentacles are on the same radii as the outer cycle of marginal tentacles, thus alternating with the members of the first marginal cycle. They vary in length from 0.2 cm. to mere tuberculiform processes, the outer being the larger. Like those of the margin they terminate in a rounded or slightly knobbed manner, and the members of each radial row are in close contiguity peripherally, but become more distant one from the other centrally. Only a few of the radiating rows reach the peristome, and the tentacles here are a little larger than those for some distance behind (Pl. x., fig. 7; Pl. xi., fig. 5).

The disc is sinuous, and usually elongated or irregular in outline. It is often reflexed at the margin, and so thin-walled that in some the movements of the internal larvæ could be distinguished. The peristome is round and considerably elevated, ending sharply at the oval mouth. The stomodæal walls show about twelve very deep, flattened folds, but no gonidial grooves are indicated.

The number of oral apertures is inconstant. Probably the majority of Jamaican examples have more than one. A specimen was come upon which possessed seven mouths of different sizes. Duchassaing and Michelotti regarded five as normal when the development is complete. An example bearing three apertures was met with in the act of vertical fission, the elongated columnar constriction being nearly broken down; others were collected, joined only by a thin basal membrane. The disc and tentacles can be completely infolded, so that no part of them is visible.

The base is white, the proximal region of the column is flesh-coloured, the distal a very dark brown or may be bluish towards the margin. The marginal

tentacles have a green, blue, or brown stem, and the knob green or yellowish-green, or white in one variety. Often there is a marked difference in colour between the dicyclic marginal tentacles and the inner radiating group. The disc is richly coloured; green or blue along the radii, but towards the inner naked area, dark purplish brown. The peristome is bright green; the walls of the stomodæum are white or light green.

Specimens were procured at Port Antonio in which the tip of the disc tentacles was coloured bright orange red. They were associated with other polyps of the more usual colours, to which they presented a marked contrast. Duchassaing and Michelotti also refer to a similar variety.

Around the Port Royal Cays two other slight colour varieties occur, also in close association; in one green and purplish brown predominate, and in the other light green or grey. They are readily distinguishable when seen *in situ* in patches of considerable size, the members of any one patch being alike, much in the same way as has often been described for groups of *Corynactis*.

The dimensions are very variable. The height of the column in extension may vary from 1.1 cm. to 2.7 cm., while the diameter may be 1.7 cm. The greater length of the disc of a specimen with four mouths, and also of one with a single mouth, was 3.5 cm.; another bearing two apertures was 5.5 cm. in extension, with a diameter of 3.8 cm., and a length of 4 cm. in contraction.

The length of the marginal tentacles of the inner eye is 0.5 cm.

#### ANATOMY AND HISTOLOGY.

In endeavouring to remove the animal from the rock to which it is attached, the base often becomes partly destroyed. Where perfect, however, the basal ectoderm is seen to be formed of elongated columnar cells, which are mostly large, unicellular glands, aggregated, along with the narrow supporting cells, around fine mesogloæal processes. A thick cuticular membrane, apparently formed of coagulated mucus, is present in some specimens between the ectoderm and the foreign object to which the polyp is attached.

The mesogloæa of the base, like that throughout the whole polyp, is a thin clear layer, and comparatively few cells are included within it. It stains slightly with borax carmine. In regard to the abundance of the mesogloæal cells, the species is intermediate between their practical absence in *Corynactis* and the great quantity in most *Actiniæ*. In the upper part of the polyp the layer is almost completely homogeneous, an included cell occurring but rarely. In these places it is indistinguishable from the mesogloæa of *Corynactis* and the *Madreporaria*. The endoderm of the base presents no important characteristics, and is practically devoid of zooxanthellæ.

As noticed among the external characters, the ectoderm of the column-wall is thrown into fine ridges and grooves. In section the former are shown to be supported by comparatively long mesoglaeal processes, which may even become branched (Pl. XI, fig. 6). Numerous clear gland cells are present in the layer, along with fewer granular gland cells; many of the former are fixed with the mucus in the act of streaming out. A very distinct though weak ectodermal musculature is seen in transverse sections, more readily noticeable on the mesoglaeal processes. The mesoglaea is thin for its whole length, and becomes even more so towards the apex. The endodermal muscle is recognizable throughout the extent of the column as a feeble layer, but the fibres become a little stronger towards the apex, though no concentration which can be regarded as a special sphincter muscle takes place. The mesoglaea is thrown into very slight folds for its support, and very fine fibrils pass from these towards the free surface of the endoderm, where the nuclei and zooxanthellae are mostly concentrated. The commensal algae are much more abundant in the distal regions of the polyps than proximally.

The marginal and the disc tentacles display a similar structure. For the greater part of the length of the stem the ectoderm contains many gland cells, and its histology closely resembles that of the column-wall. Towards the free termination an important modification takes place; the majority of the cells are no longer broad and glandular, but elongated, narrow, and closely aggregated, while deeply-staining nuclei are abundant. A peripheral zone is made up almost entirely of large elongated endocysts, with a fine spiral thread inside. In the deeper parts of the layer others are seen in different stages of development, and very distinct fibrillar and nervous layers occur just outside the ectodermal muscle. The ectodermal and endodermal musculature are both very feeble.

Professor McMurrich (p. 48) found the tentacles in the Bahaman examples characterized by the total absence of nematocysts, a condition at variance with the Jamaican representatives, where both the marginal and disc tentacles are crowded with nematocysts around their extremity, rather more so in the marginal than in the inner tentacles. In a very young specimen sectionized, however, I was unable to discover any, even on maceration.

The mesoglaea of the tentacles is extremely thin, except proximally, where it becomes broader and almost homogeneous. The ectodermal muscle is rather strong around the base of the tentacles, but weakens distally. Numerous zooxanthellae are present in the thickened endoderm.

The ectoderm of the disc contains very many, clear gland cells, and a few narrow nematocysts, and, in places, large, granular gland cells; endodermal and ectodermal musculatures on fine mesoglaeal processes are also clearly indicated. Zooxanthellae are abundant in the discal endoderm, while few nuclei are to be seen in the mesoglaea.

The stomodæal ectoderm is deeply folded, a salient feature being the comparatively large mesogloæal processes, resembling those of the column-wall, which support the folds. As shown in the section figured (Pl. XI., fig. 6), these bear no relation to the attachment of the mesenteries on the inner side. There is no modification in structure indicating gonidial grooves. Large nematocysts, such as are met with in the mesenterial filaments, occur sparingly in the ectoderm, and a feeble ectodermal musculature can be discerned.

The mesenteries are very irregular in their development, but the hexamerall condition is evidently the normal; one or more incomplete pairs may occur in the exocœles between the perfect pairs, or a pair may consist of one perfect and one imperfect mesentery. This irregular arrangement is consonant with what has been already noted for the tentacles, and is likewise probably connected with the usual method of reproduction by fission.

At least three distinct orders are indicated in most polyps, though many of the members of the third order may be wanting. The section (Pl. XI., fig. 6), of a young specimen shows thirty-six mesenteries of varying degrees of development; of these only thirteen reach the stomodæum. Another presented twenty-four pairs, of which eight pairs were perfect, though in two pairs one mesentery in each fell short of the stomodæum. A very small example sectionized exhibited only seven complete mesenteries, all arising from a region embracing little more than one-half of the circumference of the column-wall, while those arising from the remainder were all incomplete. The mesenteries become very numerous and closely arranged in large specimens.

Another polyp, sectionized later, is diagrammatically represented in transverse section in fig. 1, Pl. XII.; two pairs of directives occur, with three pairs of complete mesenteries on one side and four on the other. The members of the third order are present in some of the exocœles, but never in two pairs, one on each side of the pairs of the second order, as in the case where the cycles are developed regularly.

The retractor muscles, though feeble, are sufficiently well developed to allow of the arrangement in pairs being easily followed. No directives were distinguishable in two young specimens, but in another two pairs occurred. The parieto-basilar muscles are very distinct on each face, but the mesogloæa is smooth, and affords no indication of any basal pennon. The retractor muscles are supported, in places, on rather considerable plaitings of the mesogloæa, but the distribution of the plaitings is very irregular, and rarely presents the same appearance on any two mesenteries. In some cases they may form two or three thickened vertical bands. In the mesentery represented in fig. 2, Pl. XII., only one of these was present. Beyond the retractor region, the mesogloæa becomes extremely thin, sometimes appearing to originate from the side of the thicker part, instead of being a con-

tinuation of it. The retractor muscle extends over the whole face of the mesentery, and similarly with the oblique muscle on the other face.

The mesenterial endoderm is a rather broad layer, and, in the upper region, its cells contain numerous zooxanthellæ. Clear mucus is sometimes seen in the act of being extruded from many of the cells, and an occasional granular gland cell is present.

The mesenterial filaments have only the central portion or Nesselldrüsenstroif developed throughout their extent. This bears very large oval nematocysts with the spiral thread somewhat loosely arranged. They are located in the deeper parts of the filaments, and a narrower kind occurs at the margin. The filaments can be traced in connexion with the stomodæal ectoderm, and are nowhere very sharply marked off from the mesenterial epithelium (Pl. XIII, fig. 1).

No reproductive organs were present in the half dozen examples sectionized.

The species is found very abundantly, in water of three or four feet, growing on the coral rock around all the Port Royal Cays associated with *Actinotrix Sancti-Thomæ*; also at Laughlands, St. Ann, and at Port Antonio. Duchassaing and Michelotti record it from St. Thomas, and M<sup>c</sup>Murrich from the Bahamas.

The polyps are always aggregated in patches, often several feet across, as a result of their usual method of reproduction by fission. They display but little activity in opening and closing, the extended condition being by far the more usual. An excessive amount of clear mucus is given out on handling, rendering it very difficult to remove them from their attachment, and interfering somewhat with their proper preservation.

#### Genus.—**STOICHACTIS**, Haddon.

*Discosoma*, . . . M<sup>c</sup>Murrich, 1889, 1893; Kwietniewski (pars), 1898.

*Stoichactis*, . . . Haddon, 1898.

Discosomidæ, usually of large size; column smooth below, and with verrucæ above. Tentacles vary in form, from moderately short and subulate, to short and blunt, and even to quite small and capitate; not more than one row communicates with a mesenterial chamber. Sphincter muscle strong and circumscribed. Generally two gonidial grooves.

Consequent upon the researches of Dr. J. A. Simon (1892), on the type species of Discosoma—*D. nummiforme*, it was clear that some of the species included under the genus would have to be separated. For forms similar to the West Indian Discosomid, which M<sup>c</sup>Murrich first anatomically investigated, Haddon erects the above genus and includes, in addition, two Australian representatives—*S. Fenti*

(H. & S.) [the type], and *S. Haddonii* (S.-Kent), and also *D. Fuegiensis* (Dana). The sphincter muscle is remarkably similar in all four.

*D. tuberculata*, Kwiet., should also probably be transferred to *Stoichactis*, but not *D. ambonensis*, Kwiet., in which the tentacles are placed in radial groups, so that more than one row communicates with a mesenterial chamber.

Whether, as in the form I identify as *D. helianthus* (Ellis), a single marginal cycle of exocoelic tentacles alternating with all the endocoelic radiating rows will be found in other representatives of the genus remains to be seen. Until this is ascertained it seems doubtful if the character should be assigned generic rank, and I have therefore omitted it.

***Stoichactis helianthus* (Ellis).**

(Pl. XI., fig. 7; Pl. XIV., fig. 1.)

- Actinia helianthus*, . . . Ellis, 1767, p. 436, pl. xiii., figs. 6, 7; Ellis and Solander, 1786, p. 6.  
*Hydra helianthus*, . . . Gmelin, 1788, p. 3869.  
*Discosoma helianthus*, . . . Milne-Edwards, 1857, p. 256; Duchassaing and Michelotti, 1866, p. 122; Andres, 1883, p. 493.  
*Discosoma anemone*, . . . M<sup>c</sup>Murrich, 1889, p. 37, pl. i., fig. 8; pl. iii., figs. 15–16, pl. iv., fig. 1.

The base is a little larger in diameter than the lower part of the column; usually it is firmly adherent to the surface of rocks, or may be buried in the sand. It adapts itself to the irregularities of any object to which it is attached, and is generally deeply wrinkled in consequence; preserved examples show concentric and radiating ridges and furrows.

The column is short and salver-shaped, narrowing a little above the base, and then expanding enormously in a crateriform manner, so as to completely overhang and hide the basal part. Usually the column is only partly embedded in sand, the overhanging distal region being free and resting on the surface. Its walls are somewhat thick, but slightly transparent; the surface is smooth, and grooved in correspondence with the attachment of the mesenteries. Distally vertical rows of oval green verrucae occur, but they are evidently incapable of attaching foreign particles to the column. The apex of the column, corresponding with each mesenterial space, is slightly rounded, but is not modified to form an acrorhagus. A well-marked fossa occurs between the apex of the column and the base of the outermost row of tentacles.

The disc is greatly expanded, but remains flat, never being thrown into folds as in the next species. By far the greater part of it is covered with radiating tentacular rows of various lengths; the central, naked area is smooth, and the

peristome somewhat elevated. Towards the periphery the tentacles are so close that the actual surface of the disc can scarcely be seen; centrally, as the rows begin to cease, the disc itself is more exposed. In a large specimen, 160 rows were counted near the periphery, the longest row containing 24 tentacles, all of which communicate with the same mesenterial space; interspaces may occur at almost any point showing where tentacles have failed to develop. Usually no serial order in the lengths of the various rows is apparent, though in young examples an arrangement in three or four orders can sometimes be made out. In larger specimens, all kinds of irregularities in the way of omissions may occur; a bifid example is occasionally come upon, and small tentacles are seen in process of development all round the margin.

A single outermost cycle alternates with all the radial rows (Pl. XI., fig. 7).

Viewed from within, in dissections, the rows of tentacles are seen to communicate with the endocœlic chambers by large, closely arranged, circular apertures; the outermost cycle is exocœlic in position. The tentacles are short and digitiform, but vary a little in shape and size, according to the amount of distension; sometimes they are quite collapsed. In the preserved condition the tentacles of some polyps retain the finger-shape in all, while, in most, they become short and vesicle-like, a denser apical area denoting the extent of the distribution of the nematocysts. The surface of the tentacles may be very finely fluted, from apex to base, in preserved specimens, and the discal ectoderm forms still finer ridges and furrows.

The mouth is large and oval; two gonidial grooves are always present, readily distinguished by their thick lips. In large polyps three grooves are sometimes met with.

The base is white or cream-coloured; the column white or cream below, and a little darker above. Sometimes large, irregular, green patches may occur on the column and distally irregular vertical rows of small, oval-shaped, green areas represent the verrucæ, the number and closeness varying in the same specimen in different rows. The disc may be a lighter or darker olive brown, and the tentacles are the same, but irregular patches of different intensity are usually exhibited.

The peristome is a brownish yellow, the lips a rich yellow, the stomodæal wall white.

The waters at Port Antonio contain a remarkable colour variety. The entire column and disc, with the exception of the green verrucæ and a slight brown tint on the peristome, are colourless and perfectly transparent. The tentacles, on the other hand, are a clear, delicate, sulphur yellow. It is scarcely possible to imagine a form differing more in colour from the ordinary condition; seen on the dark sea-floor, they are very attractive objects. Odd brown tentacles may be scattered among the yellow ones, and one or two examples showed considerable areas of

the disc with the usual colours, demonstrating that we are dealing with a mere colour variety, between which and the normal every gradation may occur.

The diameter of the base is about 5 cm., and the height of the column 4 cm. The diameter of the disc is 10 to 12 cm., or may be even more. The tentacles are about 0.6 cm. in length, and vary but little in different regions of the disc. They are often largest in diameter at the tips, where they may measure 0.2 cm. across. The diameter of the naked part of the disc across the mouth is 2.5 cm.

Prof. M<sup>c</sup>Murrich's figure (1889, Pl. 1., fig. 8, *Discosoma anemone*) represents the usual appearance of the Jamaican specimens.

#### ANATOMY AND HISTOLOGY.

The column-wall is of only moderate thickness, the mesogloea being often narrower in section than the ectoderm. The latter is deeply folded, the mesogloea partly following. In the ectoderm the nuclei of the supporting cells are distributed with considerable uniformity in sections, not limited to a zone as is generally the case. Very numerous, long, granular gland cells are included among the supporting cells. There is no trace of any ectodermal musculature. The mesogloea shows a delicate, fibrous structure, and numerous included cells. On its endodermal border it presents narrow, slightly branching plaits for the support of the circular musculature, and very fine fibrils pass into the denser peripheral part of the endoderm, in some places giving rise to a distinct nerve layer. Ganglionic cells are recognizable between the muscular and nervous layers. The endoderm is much thinner than the two other layers, and contains many zooxanthellæ and granular gland cells.

Where sections pass through verrucæ, the ectoderm undergoes certain modifications: gland cells are absent, and the region stains more densely than the ordinary ectoderm. Very delicate processes, like endocils, also appear on the surface, and the remains of the layer of cilia are more obvious than elsewhere.

The sphincter muscle is a strong, circumscribed, endodermal representative. It is recognized as a large outgrowth from the column-wall, a little below the outermost cycle of tentacles, and is made up of several lobes. The pedicle is broad and short, and a narrow mesogloæal axis extends nearly the whole length. From this axis delicate processes are given off—sometimes on one side, sometimes on the other, or on both together—for the support of the musculature. The lobes are so deeply separated that often a portion of the coelenteron is enclosed in sections. The surrounding endodermal layer resembles that of the column-wall, and contains numbers of gland-cells and zooxanthellæ. Owing to the lobed character, the appearance presented by the muscle varies in different sections. As indicating the possible amount of this variation, the figure given by M<sup>c</sup>Murrich (1889, pl. III., fig. 15) should be compared with that on (Plate XIV., fig. 1).



The tentacles appear as simple outgrowths of the disc, no special sphincter being developed at their origin. The three layers are about equal in thickness, and may be a little folded in preserved material. Nematocysts are only borne towards the apex of the tentacles, but there is little or no enlargement distinguishing the capitulum from the stem. The nematocysts are rather long and very narrow, and the spiral thread inside is easily recognized. They are closely packed in a peripheral zone; below this is a broad nuclear zone; then a clearly defined thin nervous layer; and, lastly, the longitudinal ectodermal muscle on fine mesogloæal plaitings. The endoderm is crowded with zooxanthellæ and gland cells; the granular contents of the latter are in many cases in the act of being extruded into the tentacular cavity. There is only the merest trace of an endodermal musculature; endodermal nerve fibrillæ are distinguishable, but do not unite into a distinct layer, as in the ectoderm.

The ectoderm of the disc is devoid of cnidocysts, but contains numerous glandular cells with granular contents. A weak, radial, ectodermal musculature occurs, and the circular endodermal muscle is more strongly developed than in the tentacles, the mesogloæa being deeply plaited; the nerve fibrillæ are clearly seen in places, united into an extremely thin layer some distance from the muscle layer. Gland cells are abundant in the endoderm.

In a dissection of a small specimen, through the middle of the stomodæal region, twelve pairs of perfect mesenteries occurred, of which two pairs were directives; an alternating cycle of twelve pairs extended about half-way towards the stomodæum; and, of the third cycle, made up of twenty-four pairs, some extended only just beyond the column-wall, while others were larger. In other and larger specimens numerous irregularities were presented, pairs belonging to any of the cycles being missing or present in excess. The number of perfect mesenteries in these becomes very considerable, appearing as if closely arranged all round in alternating perfect and imperfect pairs as described by M<sup>c</sup>Murrich (p. 40). In one example, where the disc was exceptionally transparent, thirty-six pairs of mesenteries reaching the stomodæum could be counted.

The first part of a mesentery is narrow; it then thickens abruptly, the retractor muscle extending nearly across the face, again terminating in an abrupt manner in the imperfect pairs, but gradually in the perfect. The microscopic appearance of the retractor muscle is figured by M<sup>c</sup>Murrich. All the mesenteries in section appear at first undulating on both sides, due to the enlargement of the mesogloæa, but become straight towards the stomodæum. On the face opposite the retractor muscle a thin musculature occurs all along, but the mesogloæa is not plaited. The parieto-basilar muscle appears developed on this face only. The endoderm is loaded with glandular cells, and fine nervous fibrillæ occur between the musculature and the denser peripheral parts of the endoderm.

The parietal mesenterial stomata are small, circular apertures, located a little distance from the column-wall just below the sphincter muscle; the perioral are somewhat larger.

Gonads were restricted in one specimen to the second cycle of mesenteries. Prof. M<sup>c</sup>Murrich (1889, p. 40) found that "the reproductive organs were present on all the mesenteries, with the exception probably of the directives."

This species is very abundant in the neighbourhood of the coral reefs around Jamaica, wherever these have been examined, sometimes partly buried in the sand, but more often attached to rocks. Isolated individuals may occur, but usually a number are closely aggregated, so close, at times, as to give rise to a polygonal outline of the discs, the result of mutual pressure. The associate habit and often the presence of more than two gonidial grooves are no doubt indicative of reproduction by fission; and Prof. M<sup>c</sup>Murrich obtained several specimens at the Bahamas in various stages of division. A small, brightly-coloured Crustacean has been found on one or two occasions living on the disc; but this commensalism is evidently not so constant a feature of the West Indian species as of those described and figured by Mr. Saville-Kent, from the Australian Barrier Reef. Here a brilliantly-coloured fish and one or two species of prawns are commensal with the polyps, and may pass in and out of the gastric cavity.

My reasons for regarding the *Discosoma anemone*, described by M<sup>c</sup>Murrich, as the *Actinia helianthus*, of Ellis, are given at the end of the description of the next species.

#### Genus.—**HOMOSTICHANTHUS**, n. g.

Discosomidæ, in which the tentacles are slightly knobbed and arranged in numerous peripheral cycles and radiating rows, a single row communicates with each endocœle and exocœle. Column-wall devoid of verrucæ; disc much folded. Two deep gonidial grooves. Sphincter muscle restricted.\*

The generic term has reference to the practical similarity of all the rows of tentacles, both endocœlic and exocœlic.

\*Prof. Haddon (1898, p. 432) employs this useful term for an endodermal sphincter muscle, in form intermediate between the diffuse and the truly circumscribed types. It refers to an intermediate stage, in which the mesogæal plaitings, for the support of the musculature, do not arise from a common axis, but from several principal axes of less complexity. He further suggests "constricted" for the typical circumscribed muscle. (cf. figs. 3 and 7, Pl. XIII., "diffuse endodermal muscle"; fig. 6, Pl. XII., "restricted endodermal muscle"; figs. 1, Pl. XIV., fig. 2, Pl. XV., "circumscribed (constricted) endodermal muscle"; also, "aggregated," M<sup>c</sup>Murrich, 1893, p. 152, pl. xxii., fig. 23.)

**Homostichanthus anemone** (Ellis).

(Pl. x., fig. 8; Pl. xii., figs. 4–6; Pl. xiv., fig. 2; Pl. xv., fig. 1.)

*Actinia anemone*, . . . Ellis, 1767, p. 436, pl. 19, figs. 4, 5; Ellis and Solander, 1786, p. 6, &c.*Hydra anemone*, . . . Gmelin, 1788, p. 3869.*Discosoma anemone*, . . . Duchassaing, 1850, p. 9; Milne Edwards, 1857, p. 257; Duchassaing and Michelotti, 1860, p. 38, pl. vi., figs. 2, 3; Duchassaing and Michelotti, 1866, p. 122. Andres, 1883, p. 493. [non M<sup>r</sup>Murrich, 1889.]

The base is flat and usually buried in sand for some distance below the surface of the sea-floor; or may be fixed to rocks, gravel, or other foreign bodies. It is thin-walled and semi-transparent, the radiating mesenterial attachments showing through. In diameter it is slightly larger than the lower part of the column, but much less than the upper overhanging region. Particles of sand and gravel may adhere, and occasionally remnants of a coarse cuticular membrane. When not attached, as in the laboratory, the base is very distensible, and preserved examples exhibit radiating and concentric basal foldings.

The column for its whole length is buried in sand, and is greatly elongated, somewhat cylindrical, erect, smooth, distensible, and devoid of verrucae. Distally the internal attachment of the different orders of mesenteries is apparent through the thin wall; an additional cycle of pairs is in this way seen to commence about half-way up the column, and to extend as far as the apex. The distal region is strongly folded, and, along with the disc, overhangs the proximal region; *in situ* this area rests upon the sea-floor, or the whole polyp may be buried so that only the crests of the discal folds are visible. Around the apex of the column are small, obtuse elevations which may perhaps be regarded as acrorhagi. They are a little lighter in colour and correspond with alternate mesenterial spaces. A shallow fossa occurs between the circle of acrorhagi and the outermost cycle of tentacles. In preserved specimens the column is divided into deep longitudinal and transverse foldings. When alive the polyps are capable of considerable retraction, and, if disturbed, withdraw themselves for some distance below the surface of the sea-floor.

The disc is large, and peripherally is thrown into deep folds, nine to twelve, or even more, in number. The central naked area is comparatively small and flat, and the peristome but slightly raised. Generally the disc is only partly retracted so that its diameter is not larger than that of the column; it can, however, be completely withdrawn so as to be wholly hidden.

The tentacles are short, smooth, slightly capitate, and arranged in numerous

nearly similar rows; in a good-sized specimen over 300 radiating rows were counted. The apex may be shortly and bluntly conical. All the tentacles are of about the same size, but may vary a little with the amount of distension, sometimes becoming quite flaccid on the withdrawal of water.

The tentaculate area of the disc is divisible into two very distinct regions—an outer, in which the tentacles form about twelve cycles, each containing the same number; and an inner, in which the rows begin to terminate at different distances from the mouth. Only thirty or forty rows are continued the full length of both regions, but all extend across the first. In large specimens no serial order is obvious in regard to the lengths of the inner rows, but three or four orders can be made out in young specimens (Pl. XII., fig. 4). Peripherally, the tentacles are so closely arranged that on a slight contraction of the polyp the apices press one against the other and assume a polygonal outline, and sometimes more than one row appears to communicate with a mesenterial chamber. Small developing examples may occur among the others, especially at the margin which appears to be a region of continuous active growth. Occasionally a bifurcated tentacle is come upon, and omissions may occur here and there, especially in the inner series. Only one row communicates with each mesenterial space. The organs possess considerable adhesive power when alive, though not so marked as in the former species, and can move about independently of one another.

The gonidial grooves are very distinct, the two enclosing lips being thick and protuberant. The walls of the stomodæum are slightly ridged, and so delicate that the mesenterial lines show through. In a state of repose the mouth is comparatively small and oval, but in preserved specimens it is widely open and nearly circular.

A small specimen, only about two centimetres in diameter, which I regard as an immature form, was found at Port Antonio adhering to a *Thalassia* leaf. It differed from the ordinary condition in having several tentacles distended to two or three times the size of the others, giving the disc quite a peculiar appearance.

The colour of the base may be faint scarlet, the intensity varying in different examples; or, it may be cream-white with only minute flecks of scarlet. In most the lower region of the column is a very bright scarlet or orange-red, sometimes in small patches on a cream ground. Distally the column is dark brown or steel grey. Occasionally the column-wall may be almost devoid of colour, except in the distal region, which always passes gradually into a very dark brown. The brown coloration is evidently determined by the presence of zooxanthellæ in the endoderm. Histologically it is shown that these occur only in the upper part of the column.

The disc varies much in colour in its different regions. Peripherally, where the tentacles are closely aggregated, it is usually a uniform light or dark yellowish-

brown; more centripetally, it is divided into narrow, radiating areas separated by dark lines. Each area consists of distinct, opaque white patches, or of continuous, opaque white bands, and corresponds with the rows of tentacles. The central, naked part of the disc is darker, and usually shows a purplish tinge, and a few white flecks may be scattered about. The margin of the lips is a stronger purple. The tentacles, both in different regions of the disc, and even in different parts of the same tentacle, also vary considerably. At their origin the short stems are of much the same colour as the portion of the disc from which they arise. Many of the inner show an opaque white circle at the place of origin. The tips of most are strongly coloured; at their thickest part is an opaque white annulus, while the area immediately above may be greyish, yellowish-brown, or iridescent green. The last-mentioned condition is usually exhibited by the peripheral cycles, and the first cycle of this series often projects slightly beyond the others, its tentacles having intensely opaque white tips, which give a marked peculiarity to the colour-pattern of the disc. Usually the tips of the internal tentacles are whiter than those of the outer. At any part of the tentacular area, larger, bright green tentacles may occur.

The capitula of all the tentacles of several specimens obtained near the bathing place at Port Antonio were a bright-green, and the white opacity on the disc was absent, the whole surface, except the purple peristome, being a rich dark brown.

As mentioned by Duchassaing and Michelotti, the brighter colours are sometimes evanescent or may undergo modification. The rich, tentacular colours of some specimens kept in the laboratory, and exposed to the full sunlight for a few hours, practically disappeared, the whole disc and tentacles being reduced to a thin, opaque white and delicate brown. Others, especially those not so brightly coloured, showed no alteration.

The diameter of the expanded disc, in the living condition, varies from 10 to 15 cm., or may even expand to as much as 20 cm. The diameter of the column may be about 6 cm., but depends much upon the amount of distension; the height is from 7 to 8 cm., but in a tall jar in the laboratory the column elongated to as much as 9 or 10 cm., and swayed to and fro. The length of the tentacles is 0.4 cm., and the greatest diameter, which is towards the tips, is 0.2 cm. The disc of specimens preserved in formol is about 5.5 cm. in diameter, and the column about 3.5 cm. in height, and the same in diameter.

#### ANATOMY AND HISTOLOGY.

The basal ectoderm is a broad layer, constituted mostly of supporting cells, among which are a few granular gland cells. The mesogloea is usually narrower than the ectoderm, and is finely fibrous in character, with

many included cells. On its inner border it gives rise to short, branching processes for the support of the weak endodermal muscle. The endoderm is much the narrowest of the three layers, and, in places, shows a distinct nervous layer.

The column-wall is much and deeply folded, and is of only medium thickness, the mesoglœa throughout being of about the same breadth as the ectoderm. The fine ridges noticed among the external characters are seen in sections to be produced either by coarse bulgings, or by long, narrow processes of the middle layer. Long gland cells with granular, non-staining contents occur in the ectoderm in much greater abundance than at the base. No ectodermal musculature can be distinguished. The inner border of the mesoglœa is thrown into very delicate, branching processes for the support of the endodermal circular muscle; this extends the whole length of the column, and is often most strongly developed in the lower part of the column. At the actual apex, however, it is better developed, and gives rise to a feeble sphincter muscle of the restricted type. The endoderm is fibrillar or reticular on its mesoglœal aspect; towards the free border the cells bear zooxanthellæ, the nucleus of which stains deeply and is highly refractive. From the lower stomodæal region downwards, the algæ are practically absent from the columnar endoderm of the column, and none occur at the base.

Considering the magnitude attained by the polyps, the sphincter muscle (Pl. XII., fig. 6) is remarkably feeble. The fibres are arranged on a few, narrow, branching mesoglœal processes, developed for some little distance along the apex of the column-wall, the whole being intermediate in form between a circumscribed muscle, such as that of *Stoichactis*, and a diffuse sphincter, as in *Corynactis*. In truly radial sections, the middle mesoglœal processes are a little longer and more branching than are represented in the partly tangential figure given, very closely resembling those of *Radianthus macrodactylus* (H. & S.), figured by Haddon (1898, pl. xxxi., figs. 2, 3). In complete retraction of the polyps, the disc can be entirely hidden.

The tentacles are all alike in structure. The apex is crowded with long narrow nematocysts showing the internal spiral thread; an occasional granular gland cell also occurs. A marked histological difference is apparent between the capitulum and the stem, nematocysts occurring only in the former. In the stem the ectoderm is narrower, and gland cells are more numerous, while the mesoglœa thins towards the apex. The endoderm is a thick layer, with irregular internal boundaries; small zooxanthellæ are abundant, and less so glandular cells with highly refractive contents. Both the endodermal and ectodermal muscles are very feeble, and connected with the latter, a fibrillar and a nervous layer show very distinctly at the capitulum. Nematocysts are absent from the ectoderm of

the disc, gland cells occur, and the endodermal muscle is much stronger than in the tentacles.

The stomodæum is greatly folded in all the sections, the ectoderm being followed by long, narrow or broad processes of mesoglæa. The first layer is densely crowded with large, granular gland cells extending completely across, but stinging cells are rare. A very delicate nerve layer can be discerned, and the merest trace of ectodermal and endodermal musculatures. Zooxanthellæ are scarce in the endoderm, but gland cells are numerous.

The gonidial grooves are interesting in the amount of histological detail indicated, and remarkable for the enormously exaggerated endoderm (Pl. xiv., fig. 2). The ordinary stomodæal ectoderm and mesoglæa narrow just before reaching the groove, and then all the three layers become much thickened, the endoderm most so. In the ectoderm, the nuclei are nearly all restricted to a narrow, extremely well-defined zone, a little below the ciliated margin; for a short distance within this zone the layer is almost clear, and then another nucleated zone is apparent, but in this case the nuclei are much fewer and do not stain so deeply. Then comes another clear zone, and afterwards a nervous layer from which fibrillæ extend to a very feeble muscle layer, apposed to the inner face of the mesoglæa. Ganglionic cells are scattered here and there among the fibrillæ. The whole succession of details can be easily traced all round the gonidial ectoderm. The mesoglæa is smooth on its ectodermal aspect, but the endodermal aspect is irregular; it is finely fibrous in structure, and many isolated cells are included.

The endoderm of the groove is enormously swollen, and of peculiar structure. Nearly all the nuclei and protoplasmic contents are aggregated towards its periphery, the greater portion of the layer appearing highly reticular in section; granular gland cells are scattered about, more numerous towards both its internal and external limitations. The mesoglæa of the directive mesenteries as it passes through the endoderm is extremely narrow.

Several specimens dissected transversely exhibit numerous pairs of mesenteries, arranged in four orders. The number is very variable, no two of the examples being alike. Two gonidial grooves and two pairs of directives were, however, present in each case. To the naked eye both sides of the groove are smooth, and readily distinguished from the rest of the stomodæum by being unfolded; the mesoglæa and endoderm are also much thickened. Twelve pairs of perfect mesenteries were present in a transverse dissection through the middle stomodæal region of a rather small polyp, and also second and third imperfect cycles. In places these exhibited the normal regularity, but in some of the exocœles additional imperfect pairs belonging to lower cycles occurred, and all stages in the development of new pairs could be traced. In another polyp between thirty and forty pairs of perfect mesenteries were counted in sections through the middle stomodæal region,

while some of the free pairs were attached higher up. The members of the fourth cycle extended only a short distance from the column-wall. It would thus appear that the normal arrangement of the mesenteries in the stomodæal region of young polyps is as follows:—the first cycle of twelve pairs of perfect mesenteries constitutes the first and second orders; a second cycle is formed of twelve alternating pairs; and a third cycle of twenty-four pairs. Beyond this irregularities begin to step in. In older specimens many more than twelve pairs become united with the stomodæum. The region of the directives is always that of most forward growth.

The mesenteries present a concave outline as they cease their connexion with the stomodæum, so that in sections through the lower region of the latter the free edge of the mesenteries, bounded by a mesenterial filament, appears twice, one part being in connexion with the column-wall, and the other, shorter part with the stomodæum. The six mesenteries of the second series become free in advance of those of the first.

The retractor muscles extend across nearly the whole face of the mesentery, but are nowhere much thickened, resembling somewhat those of *S. helianthus*. They differ in this respect from those of *A. elegans*, which are circumscribed and project considerably.

The parieto-basilar muscle is strongly developed on both faces, and supported on numerous fine mesogloæal plaitings, but a separate pennon is not present, at any rate in the upper region. The nervous layer and fibrillæ are very distinct in this region.

The retractor muscle commences abruptly and extends along the greater part of the face of the mesentery, terminating more gradually centripetally. The mesogloæal processes are long, narrow, and branching, and constitute nearly the whole of the thickness of the mesentery. The endodermal epithelium is very narrow comparatively, and contains numerous granular gland cells. There is little trace of any oblique musculature. The mesenteries are very narrow beyond the retractor region.

The mesenterial filaments are typical in character, closely resembling those of *Phymanthus crucifer*, already described. The trilobed condition occurs on the first two or three cycles, and is continued for but a short distance below the aboral termination of the stomodæum. The Nesseldrüsenstreif or glandular streak at the apex of the middle lobe, is very limited in its extent, and the first portion of the intermediate streak is characterized by an abundance of small zooxanthellæ. The Flimmerstreifen or ciliated streaks also occupy but a small region of the lateral lobes. The cells of the reticular streak contain but little protoplasm, while the mesogloæal axis in all three lobes is crowded with small, deeply-staining cells.

Below the stomodæum the mesenteries branch considerably at their free extremity, each division being terminated by a simple, more or less rounded filament. As each side of the filament approaches the mesenterial epithelium, its



cells stain more deeply, and, compared with the more apical region, fewer gland cells are discernible.

At various places around Port Antonio, on the north-east side of the island, the species occurs in some abundance, usually with the column and part of the disc buried in the sand or among the roots of various marine plants, such as *Thalassia* and *Ruppia*. In water of from 4 to 5 feet around the bathing place belonging to the Titchfield Hotel many specimens are to be found, including the green variety. It does not affect a social habit, as is often the case with the previous species, and is entirely absent from around the Port Royal Cays and other spots on the south side of the island.

Duchassaing and Michelotti met with the form at Guadalupe and St. Thomas. Ellis records it merely from the West Indies.

Though there can be no doubt as to the distinctness of these two West Indian Discosomids, yet, owing to the incomplete descriptions and figures of the earlier authors, some difficulty exists as to their identification with one or the other of Ellis's species. Assuming that the distinctions between the two forms indicated by Ellis were simply due to different degrees of contraction, or to age, Professor McMurich regarded them as synonymous, and describes both as *D. anemone*. Notwithstanding the few details given by the older writers, there is every likelihood that McMurich's Bahaman representative is really the *helianthus* of Ellis, and also of Duchassaing and Michelotti, and this is the determination which I have followed above. Ellis mentions the flat salver-shape for *helianthus*, while Duchassaing and Michelotti refer to the greenish-brown verrucæ; again, Ellis records the angular form of disc of *anemone*, and the two later authors refer to the colour variation.

I follow Haddon (1898, p. 473) in transferring *helianthus* (= *anemone*, McMurich) to his new genus *Stoichactis*, and find it necessary to erect another genus for *anemone*.

The following tabulated characters will enable the two to be readily distinguished in collecting:—

*Stoichactis helianthus.*

Polyps often closely associated. Column short, salver-like, verrucose, usually not embedded; little retractile power.

Disc flat; an outermost cycle of tentacles alternates with all the other rows. Occasionally more than two gonidial grooves.

Colour of tentacles mostly greenish yellow, with lighter and darker patches; undergo no rapid variation in colour.

*Homostichanthus anemone.*

Polyps scattered. Column long, cylindrical, non-verrucose, usually completely buried; capable of considerable retraction.

Disc sinuous; a series of about twelve cycles of tentacles constitutes a distinct peripheral zone. Only two gonidial grooves.

Colour of tentacles bright emerald green, with opaque white and brown; stronger colours readily change in intensity.

Genus.—**ACTINOPORUS**, Duchassaing.

*Actinoporus*, Duchassaing, 1850; Duchassaing & Michelotti, 1860.

Discosomidæ, in which a radial tentaculate area, bearing more than one row of tentacles, communicates with each mesenteric chamber. Tentacles all vesicle-like, either simple or lobed, no distinction between a peripheral and an inner series. The column-wall is provided with verrucæ distally. Sphincter muscle strong and circumscribed. Mesenteries all complete. A weak ectodermal musculature on the column and stomodæum.

The genus was instituted by Dr. Duchassaing (1850, p. 10) for a single West Indian species of anemone, differing much in regard to its tentacles from any other known form. Later, in collaboration with Michelotti (1860, p. 46), he gives a further description of the genus, in which he evidently regards the tentacular areas as homologous with the frondose areas occurring in *Oulactis*, the internal cycles of ordinary tentacles, present in the latter, being wanting.

An acquaintance with these two genera demonstrates, however, that no such relationship can be sustained; the frondose areas in *Oulactis* are of columnar origin, and occur outside the sphincter region, while those of *Actinoporus* are discal, and within the sphincter region.

The most salient character of the genus is the occurrence of more than one row of tentacles communicating with each endocœle and exocœle, a feature unique among the Actiniaria, unless the same may be said of *Actinodendron* and of *Discosoma ambonensis*. Kwietniewski (1898, p. 410) describes the tentacles of the latter as in radial groups, a condition which seems to me, should certainly warrant at least the generic separation of the form from other Discosomæ, in which only one radial row communicates with each mesenterial chamber.

In the tentacular areas of the oral disc one may perhaps see some relation of degree between this genus and *Actinodendron*. In this latter, as figured and described by Haddon (1898), the forty-eight tentaculate areas, which likewise correspond with both the endocœles and exocœles, are prolonged for some distance as non-retractile lobes, and the tentacles on them are small, arise in an irregular manner, and are dendritic or form "conical bossy agglomerations." One may perhaps regard the lobes of *Actinodendron* as extensions of the sharply defined areas in *Actinoporus*, and the dendritic tentacles as exaggerations of the vesicular outgrowths in the West Indian genus.

From an acquaintance with only a single specimen of *Actinoporus*, it would be premature to regard the possession of only one gonidial groove (monoglyphic), associated with two pairs of directives, as a constant generic character.

**Actinoporus elegans**, Duchassaing.

(Pl. x., fig. 9; Pl. xi., fig. 8; Pl. xiii., figs. 2, 6; Pl. xiv., fig. 3; Pl. xv., fig. 2.)

*Actinoporus elegans*, . . . Duchassaing, 1850, p. 10; Milne-Edwards, 1857,  
p. 277; Duchassaing and Michelotti, 1860,  
p. 46, pl. vii., fig. 6; 1866, p. 132.

*Aureliania elegans*, . . . Andres, 1883, p. 497.

The base is buried to a considerable depth in sand and gravel, and is thin-walled, the lines of attachment of the mesenteries showing through; towards the margin it may also be deeply grooved in correspondence with the mesenteries. In diameter it is scarcely larger than the column.

The column is greatly elongated, cylindrical, smooth, strongly ridged and grooved above and below, and, but for a thin opaque whiteness, nearly transparent. A row of circular transparent verrucæ occurs on all the ridges, rendered very evident by the absence of the opaque whiteness, they appear more like vesicles in the preserved polyp. Along some ridges the transparent discs are not so perfectly circular as on others, and they may be in more than a single series, or even become contiguous. In the preserved condition the column is coarsely wrinkled transversely, less so longitudinally, and is of greater diameter above than below. A smooth, deep fossa exists between the marginal verrucæ and the tentacles.

The disc is flat or partly folded, not much broader than the column, and made up of forty-eight long, radiating, triangular areas, separated one from the other by deep, smooth sulci. A small, central area is naked and smooth. The areas bear extremely short, capitate or spheroidal tentacles, which seem to be little more than small vesicular outgrowths of the disc. These are often bifurcated or lobed, and extend from the fossa to near the mouth, increasing a little in size from within outwards. Odd smaller vesicles occur among the larger. Over the greater part of the disc the tentacles arrange themselves approximately in two rows along each side of a radiating area, but they communicate in an irregular manner with the cœlenteron. Towards the centre of the disc they form but a single row along the middle of the radiations. Some rows extend slightly more centrally than others, but no serial arrangement can be distinguished.

As a whole the tentacles give to the disc, both in the living and preserved condition, a finely beaded appearance; peripherally they completely hide its actual surface, but are more distant towards the middle. They possess apparently no power of retraction, and communicate with both the endocœles and exocœles,

though a slight disparity occurs in that forty-eight rows occur, while there are twenty-five pairs of mesenteries, forming, of course, fifty mesenterial chambers. The disc overhangs the column a little, and can be almost completely retracted.

The base presents a very delicate opaque whiteness, and nearly the whole superficial area of the column shows a similar opacity, particularly evident in the upper region; clear and transparent areas may, however, remain in places, as at the verrucæ. In the more distal region some of the ridges may be a delicate transparent brown. The colours of the knobs of the tentacles are variable, and not arranged according to any definite pattern. They are mostly opaque white, with various mottled colours on a clear transparent ground; spots of yellow, brown, pink, red, and white are irregularly mingled. The marginal tentacles are more spotted with opaque white than are those more internal. Preserved in formol the specimen changed its colour as a whole to a dark brown.

The column may extend to as much as 15 cm. (6 inches) in height, and is about 5 cm. in diameter.

#### ANATOMY AND HISTOLOGY.

The ectoderm of the base is an exceptionally deep layer. Large numbers of long, unicellular glands occur of about the same diameter throughout, and contain finely granular matter.

The mesoglœa is narrower than the outer layer, and is slightly fibrous in character; numbers of small cells are included within it. Internally it is finely plaited for the support of the endodermal muscle, which is here feebly developed. The endoderm is the narrowest of the three layers, and presents irregular internal limitations, and many granular gland cells.

The column-wall is much and deeply folded, and of moderate thickness in each of its three layers. Peripherally the ectoderm appears somewhat dense, owing to the great abundance of unicellular glands with finely granular contents; the cells extend from the inner limits of the layer, but become more swollen towards the outer surface. Though the polyp was nearly transparent when alive, the column-wall changed to an opaque dark brown on preservation in formalin, and the contents of the ectodermal cells appear yellowish brown on microscopic examination. The nuclei of the ectodermal supporting cells are mostly aggregated within a middle zone, and a slight ectodermal musculature is developed.

The fibrous nature of the mesoglœa is more obvious in the column than at the base, and the layer is very irregular in its outline, giving rise to numerous, deep folds on both its outer and inner aspects. On its endodermal border it forms, in addition, long, narrow, branching processes for the support of the strong,

endodermal, circular muscle. Towards the proximal region of the column, these processes become more numerous and longer, being even longer than the mesoglaea is broad.

The endoderm is devoid of zooxanthellæ, and such is the case throughout the polyp. For some distance from the mesoglaea it is constituted largely of delicate fibrils, while the protoplasmic contents are aggregated near the free, irregular border. A nervous layer is distinctly shown in places.

Sections through the verrucæ present no histological difference from the rest of the column-wall, except that all three layers are thinner and the musculature is weaker. It is doubtful as to how far they can be compared with the verrucæ in the species already described. They certainly possess no adhesive power.

The ectoderm at the fossa is strongly ciliated, the cilia being still obvious in preserved material, though this is not the case elsewhere on the column.

The sphincter muscle (Pl. xv., fig., 2) is an enormous, circumscribed, endodermal representative, hanging by a very narrow base from the floor of the fossa. Even to the naked eye it is a very pronounced outgrowth, 7 mm. in length. It breaks up into many large lobes, the appearance differing much in different sections, and in places seems to enclose portions of the cœlenteron. A narrow mesoglaeal axis extends down the middle, and from it branching processes arise in a somewhat pinnate manner, and are continued into each lobe. A peduncle is practically absent, and the mesoglaea of the sphincter is in continuity with that of the column-wall only within very narrow limits, the ordinary endodermal muscle being traceable nearly across the connexion. The mesoglaeal processes branch very much; the lining muscle fibres are not represented in the figure. Though differing in detail, and many times larger, it will be seen, on comparison of the two figures, that the muscle is exactly of the same type as that in *S. helianthus* (Pl. xiv., fig. 1). It is probably the largest circumscribed sphincter known in any Actinian.

In radial sections through the disc, the tentacles are displayed as crowded, irregular, thin-walled, vesicular outgrowths of the disc; and, compared with those of the column, each of the three component layers undergoes some modification. The ectoderm loses its gland cells, and the outer half is constituted almost entirely of a clearly-defined zone of small nematocysts; the inner half of the ectoderm, on the other hand, appears as a nuclear zone. Neither an ectodermal nor an endodermal musculature is distinguishable, and the mesoglaea is nowhere plaited. The endoderm is very narrow, and brown pigment granules take the place of zooxanthellæ.

Where a section passes through a group of tentacles (Pl. xiv., fig. 3), the disc is indistinguishable from the tentacles themselves, and the two are practically alike in structure, the disc being thin-walled and possessed of a nematocyst layer; a

feble circular endodermal muscle is, however, present in the perioral region of the disc.

The tentacles in this species therefore differ from those of the two previous forms in not having a capitulum histologically distinct from a stem, and also in not being much differentiated in structure from the disc itself.

Towards the middle of the disc, that is, in the naked area, the details, however, approach more closely those of the column; gland cells, with highly refractive contents, occur in the ectoderm, and the endodermal muscle is stronger.

The wall of the stomodæum is much folded, both vertically and transversely. The ectoderm is broad, ciliated throughout, and bears numerous, long, granular, gland cells, and a less number of oval-shaped nematocysts, much larger than those of the tentacles. A very weak ectodermal musculature is discernible. The endoderm is slightly pigmented like that of the disc and tentacles, and contains a few highly refractive gland cells.

A transverse section through the polyp, in the middle stomodæal region, shows to the naked eye the following details:—

Twenty-five pairs of mesenteries, all of which are complete; of these two pairs are directives, so that of the other pairs, twelve occur on one side, and eleven on the other. No incomplete mesenteries are developed. A single deep gonidial groove, with very smooth walls and much thickened mesogloea, is included between one of the pairs of directives, but no indication of a second is presented in connexion with the opposite pair.

The inner mesenterial stomata occur just within the lips, and the outer a little from the column-wall, about a centimetre below the sphincter muscle. Both are rather large apertures of about equal size. The retractor muscles of the mesenteries are large, thick, oval, or reniform projections from one face, and are attached by only a narrow, short pedicle; on the opposite face of the mesentery a very distinct pennon arises a little beyond the insertion of the mesentery in the column-wall.

In a section below the stomodæal region, the same twenty-five pairs of mesenteries occur, and, with their mesenterial filament and gonads, completely fill the coelenteron. Towards the basal part of the column, alternate larger and smaller pairs are exhibited, but irregularities occur, in one region seven pairs being of the same size. The number of mesenteries bearing mesenterial filaments begins to diminish, until a little above the base they are met with only on four. In the single example studied, the gonads were bright red in colour, and a reddish oil was extracted by alcohol.

The microscopic appearance of a portion of a mesentery, near its place of origin in the column-wall, is represented in Pl. XIII., fig. 2. The pennon is seen to be strongly developed, and the mesogloea long and deeply plaited on both sides. In the

upper region of the column, from which the figure was taken, the pennon is near the wall, but below it becomes further and further removed as the parieto-basilar muscle becomes stronger.

The enormous circumscribed retractor muscle of each mesentery is arranged on branching, mesogloæal processes, the mesogloæal axis from which they arise being very thin. The muscle layer is continued along the face of the mesentery beyond the swelling as far as its connexion with the stomodæal wall, but the mesentery, as a whole, is very thin, both before and beyond the enlargement. The mesenterial endoderm contains abundant, deeply-staining, granular cells, and a nervous layer is distinctly separable in places, especially near the pennon.

The mesenterial filaments are trilobed in the upper region, and exhibit the usual details of structure. The glandular and intermediate streaks are densely crowded with gland cells with brown granular contents. Proximally the middle lobe becomes highly glandular; and the mesenterial endoderm immediately behind is swollen. Its cells, along with those of the mesenterial epithelium, contain much dark granular matter.

Female gonads occurred on prolongations of some of the mesenteries, but, owing to the crowded condition of the cavity it was impossible to determine their precise arrangement. In the gonad region the mesogloæa of the mesenteries becomes extremely thin, the endodermal epithelium is much broadened, and the contents of the cells highly granular in character, while pigment granules and granular gland cells occur along the margin.

So far as could be determined from dissections, the twelve pairs of mesenteries constituting the first and second orders, and including the directives, are fertile.

I have identified this peculiar species as the *Actinoporus elegans*, of Duchassaing, although certain differences call for notice. The colour in the Guadaloupe specimens is stated to be blue, and the tentacles reddish white, while the length is given as 35 mm. It is a species which suggests the possibility of much colour variation, but it seems a little remarkable that the Jamaican specimen should be three or four times larger than the others.

Only a single specimen was obtained from along the shore to the east of Wood Island, Port Antonio, during the temporary establishment at the latter place of a Marine Laboratory in connection with the Johns Hopkins University. This was collected by Dr. H. L. Clark, and kindly handed over to me. Although the locality was afterwards carefully searched on many occasions, no other example could be found. The column was buried for a considerable distance in the muddy sand, the disc alone being exposed. Large specimens of *Asteractis*, which have the same habit, occur in the vicinity. The skeleton of a crab, with all the

flesh digested, was extruded by the animal while under observation in the laboratory.

MM. Duchassaing and Michelotti obtained their specimens upon submerged rocks at Guadaloupe.

Andres places the species, as *Aureliania elegans*, among his *Aurelianiidæ dubiæ*. It is undoubtedly a Discosomid as here defined, and not enough is yet known of the British Aureliania to warrant such a generic relationship. The perfect similarity of type of its sphincter muscle with that of *S. helianthus* must be taken into account in any consideration of its relationships.

Family.—CORALLIMORPHIDÆ, Hertwig.

*Corallimorphidæ*, . . . Hertwig, 1882 ; M<sup>c</sup>Murrich, 1893 ; Haddon, 1898.

*Corynactidæ*, . . . Andres, 1883.

Stichodactylinæ, in which the tentacles are all of one form, capitate, and comparatively few; a distinction between a peripheral cyclic series and an inner radial series may or may not be apparent. Muscular system weak in all parts of the body; sphincter muscle absent or weak.

This family was established by Professor R. Hertwig (1882, p. 21) for the reception of two species of "Challenger" Actiniæ, both belonging to the genus *Corallimorphus* of Moseley (1877). The genus was considered to bear a close relation to both *Discosoma* and *Corynactis*, and, in the "Supplement" (1888, p. 10), the latter is definitely included in the family. In his great work, published a year later, Andres employed the more preferable family name *Corynactidæ* to embrace the genera *Corynactis*, *Corallimorphus*, and *Capnea*. Of the two terms having thus practically the same significance, Hertwig's, bearing priority, must be the one employed.

The characters which Hertwig regarded as of greatest diagnostic importance in the genus *Corallimorphus*, and which at that time held also for the family, were, "the double corona of tentacles, the equal distribution of the reproductive elements, and the absence of the circular muscle." These can now be retained only for *Corallimorphus*. In *Corynactis* there is not the same distinction between an outer and an inner series of tentacles, the distribution of the gonads is not fully known, while a circular muscle, though not strong, certainly exists.



Genus.—**CORYNACTIS**, Allman.

- Corynactis*, . Allman, 1846; Johnson, 1847; Milne-Edwards, 1857; Gosse, 1860; Andres, 1883; Hertwig, 1888; Haddon, 1898.  
*Draytonia*, . Duchassaing and Michelotti, 1866.

Corallimorphidæ, in which the column-wall is smooth, tentacles knobbed, arranged in several cycles and in radiating rows, the outer larger than the inner. Tentacles and mesenteries generally tetramerous. Gonidial grooves present or absent. An ectodermal longitudinal muscular layer on the column-wall and on the stomodæal wall; endodermal sphincter muscle very weak. Mesenterial filaments devoid of ciliated streak. Mesogloæa practically homogeneous.

All the representatives of the genus are small polyps, and the descriptions of the various species given by the older writers refer only to the external features. The most salient of these are the knobbed tentacles, and the communication of more than one with a mesenterial space. In the present species, and in *C. viridis*, they are tetramerous, but in *C. carnea*, Stud., according to Kwietniewski's (1898) observations, the mesenteries appear to be hexamerous.

Professor Hertwig (1888) was the first to make a histological examination of any member of the genus, and to discover the presence of longitudinal muscle fibres on the outer side of the body-wall. Professor Haddon and myself (1896, p. 152) found the same in *C. australis*, and Haddon (1898, p. 467) in *C. hoplites*.

MM. Duchassaing and Michelotti erected the genus *Draytonia* for the species about to be described, distinguishing it from *Corynactis* on account of the circle of green spots upon the capitulum and disc. In the specimens which I have examined, the pigment spots do not project above the smooth surface, and those on the column cannot be in any way regarded as acrorhagi, and may or may not be present. They are certainly not deserving of generic distinction.

Haddon (1898, p. 468) refers to the curious fact that an "emerald green ring round the capitulum is characteristic of forms so widely distributed as European Seas (*C. viridis*), off the coast of Buenos Ayres (*C. carnea*), and Port Phillip, Australia (*C. australis*)." In the present instance the ring is represented by a circle of spots of the same colour.

***Corynactis myrcia*** (Duchassaing and Michelotti).

(Pl. x., fig. 10; Pl. xii., fig. 7; Pl. xiii., figs. 3-5; Pl. xv., fig. 3.)

- Draytonia myrcia*, . Duchassaing and Michelotti, 1866, p. 124, pl. ii., fig. 8.  
*Corynactis myrcia*, . Andres, 1883, p. 485.

The base is spreading, and in diameter larger than the column. It is irregular

in outline, tough, and firmly adherent to various objects. Polyyps are met with in groups, and are occasionally found connected, one with another, by a thin basal expansion or cœnosarc. The column is short, mammiform or cylindrical in retraction, irregular in outline below, and circular or oval above. The surface is smooth, and the walls thin and translucent, the lines of attachment of the mesenteries showing through, and dividing the whole column into slight ridges and furrows.

The tentacles are arranged in cycles and in radiating rows, each row communicating with one mesenterial space. In one specimen in which the tentacles could be counted they numbered 48, arranged in four cycles in the formula 8, 8, 16, 16. The innermost tentacles are very short, appearing as mere tubercles on the disc; the intermediate show a distinct stem and knob, while the outermost are still larger, and overhang in extension; the stems are conical, and the knobs rounded. The disc is oval or circular, smooth, thin-walled, and nearly transparent, the mesenterial lines showing through; the oral cone may be very prominent. The mouth is oval; the walls of the stomodæum are deeply ridged and furrowed, and very protrusible; no gonidial grooves are indicated. The disc and tentacles may be entirely hidden in retraction.

The column is brown below, and almost colourless or crimson above; a circle of small, emerald green, capitular spots may or may not be present. The stems of the tentacles are translucent and colourless or yellowish; the knobs rose, red, or orange. The disc is brown, with white radiating lines; the peristome bears a narrow circle of emerald green spots; the stomodæal wall is white.

When retracted, the polyyps measure about 0·7 cm. in diameter, and are the same in height.

#### ANATOMY AND HISTOLOGY.

Examined histologically the ectoderm of the base and also of the column-wall is remarkable for the abundance of large unicellular mucous glands, mingled with the narrow supporting cells. They appear to constitute the greater part of the layer, becoming more swollen towards the free surface, where they give rise to an almost clear zone. The contents are sometimes clear and homogeneous, and do not stain in borax carmine; in most cases, however, they are finely granular, and take up the colour slightly. The nuclei of the supporting cells are arranged in a zone a little within the middle of the layer, while the most internal region of the ectoderm exhibits nerve and muscle fibrils. The ectodermal musculature is discernible on the base, but becomes stronger on the column-wall, the cut ends of its fibrils appearing as a very distinct layer in transverse sections.

Throughout the base and column-wall the ectoderm remains a high columnar

epithelium, and in the latter is considerably folded in preserved material, the foldings being followed by the mesoglæa. A cuticle is not distinguishable.

The mesoglæa is very variable in thickness, owing to its numerous foldings. It is remarkably clear and homogeneous; no fibrillar structure is indicated, and it is practically devoid of any structural elements, isolated cells occurring with extreme rarity. Even after the other structures of the polyps have been deeply stained the mesoglæa remains colourless and indistinguishable from the field of the microscope. The same phenomenon is presented throughout the polyp, and evidently throughout the genus, and is that characteristic of the mesoglæa of the *Madreporaria*.

The endoderm of the base and column is scarcely narrower than the ectoderm, and gland cells with dense, highly-refractive contents, occur sparingly. Zooxanthellæ are absent throughout the polyp. The circular endodermal muscle is feebly developed in the base, but becomes stronger in the column, being supported on small mesoglæal plaitings, and enlarges distally to form the sphincter muscle.

The sphincter muscle (Pl. XIII., fig. 3) is endodermal, and intermediate in character between a diffuse and restricted form. The muscle fibres are very strong and closely arranged, and become concentrated on long mesoglæal processes; these latter, however, never become so long and branching as in *C. viridis* and *C. carnea*, but are stronger than those of *C. australis*.

The knobs of the tentacles consist almost wholly of a very deep ectoderm; the mesoglæa and endoderm extend into them but a short distance, and they never exhibit any lumen.

An outer broad zone of the ectoderm is largely made up of very long, narrow nematocysts showing the internal spiral thread distinctly. Occasionally a large, oval, stinging cyst is also seen, and in the deeper parts of the ectoderm are abundant, oval-shaped, deeply-staining bodies, evidently nematocysts in various stages of development, though some are granular gland cells. The endoderm contains an extraordinary quantity of granular pigment matter.

The ectoderm of the stems (Pl. XIII., fig. 5) is devoid of nematocysts, and in structure is much like that of the column-wall, being highly glandular. A weak ectodermal musculature is supported on branching, mesoglæal processes. From the muscle fibres on these processes very delicate fibrils radiate in a peculiar brush-like manner. The muscle is better developed proximally than distally, and is practically absent from the knob. Internally the mesoglæa forms deep, rounded plaits recognizable in longitudinal sections. The endodermal muscle is very weak, and the endoderm contains but little of the granular matter so abundant in the knob; the tissue nearly fills the lumen in retracted examples.

The disc closely resembles the stem of the tentacles in structure; the mesoglæa

is delicately plaited for additional support to the endodermal and ectodermal musculature.

The stomodæum is oval in transverse sections, and the ectoderm is thrown into about twenty very deep and regular longitudinal folds, the mesoglœa also following. In position the folds bear a rough approximation to the points of attachment of the complete mesenteries. No indication of gonidial grooves is presented. Haddon (1898, p. 468), on the other hand, found three gonidial grooves in one example of *C. hoplites*, and one in another.

The stomodæal ectoderm is uniformly ciliated, and the supporting cells give rise to the usual zone of brightly-staining nuclei; several varieties of nematocysts are represented, and various kinds of elongated, granular gland cells.

Following the folds of the ectoderm the mesoglœa is very thick and triangular in transverse section, but between the folds it becomes extremely narrow; a weak musculature occurs on both its ectodermal and endodermal surfaces. The endoderm is a broad layer, constituted largely of gland cells, some with clear contents, and others which are granular and stain readily.

The mesenteries are tetramerous and arranged in three cycles; eight perfect pairs, of which two pairs are directives, represent the first and second cycles, and are about equally developed, while eight, incomplete, alternating pairs represent the third. In the upper region of the stomodæum an odd member of the free series may be connected with the stomodæal-wall for some distance, and, in one or two cases, remains attached for practically the whole stomodæal extent. This is especially noticeable in the region of one of the pairs of directives, as compared with the lateral pairs. In one instance an odd member of two pairs of the third cycle is connected with the stomodæum throughout its length, but on one side it is the mesentery next the directives, while in the other it is the next but one which is perfect. This latter condition is shown in Pl. XIII., fig. 4, where the second mesentery from the left, belonging to the third order, has just ceased its connexion at the termination of the stomodæum. Otherwise the regularity of the mesenteries in this species is in striking contrast with the lack of symmetry met with in other representatives of the genus.

The mesoglœa of the mesenteries is thick for some distance from its origin in the column-wall, and on one side it then forms plaits of greater or less complication (Pl. xv., fig. 3). These are of the same character as in *Corynactis australis*. The folds support the vertical retractor muscle, which also extends along the whole face of the mesentery. In no case does the muscle give rise to a thickened band, as in most members of the Actiniæ.

Beyond the region of greatest plaiting the mesoglœa narrows considerably; and here, in the proximal part of the polyps, the surface of the mesoglœa of the opposite face also becomes delicately plaited for the support of the oblique

musculature. Distally the mesenterial endoderm closely resembles that of the column-wall, but contains a greater number of the glandular cells, with highly refractive contents. Proximally it becomes swollen, and contains many granular particles of various sizes, while elongated gland-cells are still more numerous.

The parieto-basilar muscles are developed for some distance along each face of the mesentery, and are continued a short way on to the column-wall. There is no trace of any mesogloæal folding or pennon.

Both cycles of perfect mesenteries remain connected as far as the inner termination of the stomodæal-wall. I have not been able to determine any definite order in which they become free, but the directives at one end remain united further than the opposite pair, the laterals being the first to cease their connexion.

The imperfect mesenteries project for some distance within the cœlenteron. In section they are almost as broad as the complete mesenteries, and the mesogloæa terminates in numerous processes, each surrounded by a muscular layer, which, so far as it extends, is as strongly developed as on the first cycle. All the endocœlic and exocœlic spaces are practically equal, and the mesenteries by no means fill the cœlenteric space.

The terminal edge of the stomodæum is reflected as a whole, so that in sections through this region the wall is double in all its three layers (Pl. XIII., fig. 4). The reflected ectoderm passes for some little distance outwardly along each face of the mesenteries, and appears in perfect continuity with the tissues forming the mesenterial filaments. At first the filaments are very irregular and narrow in outline, forming only a slightly rounded termination to the mesenteries; they are, however, histologically very distinct from the rest of the mesenterial epithelium. Lower they become more characteristic, and are either rounded or cordate in section (Pl. xv., fig. 3).

The mesenterial filaments are remarkable in that only the middle terminal lobe, the glandular streak or Nesselldrüsenstreif, is ever developed; the lateral lobes, bearing the ciliated streak or Flimmerstreifen, so characteristic of most Actiniaria, are never produced.

A little below the aboral termination of the stomodæum the mesenterial endoderm is considerably swollen immediately behind the filament, so as to produce in section somewhat the appearance of a trilobed filament; but these enlargements cannot be regarded as at all comparable with the lateral lobes of the more usual Actinian filament. Except in length of the constituent cells they differ in no important respect from the remainder of the mesenterial epithelium into which they often graduate insensibly, while the distinctly lobed character is not presented by all the mesenteries. Further, the mesogloæal axis never sends a branch into these swellings for the support of the cells, as is the case where the Flimmerstreifen are developed. Such a filament is characteristic of the Madreporaria, and

occurs also in the proximal region of many Actiniaria after the ciliated streak has ceased to exist.

The mesoglaeal axis of the mesentery, completely surrounded by a weak musculature, passes into the base of the filaments, and there becomes slightly expanded, sending a branch to each side. The cells on the anterior or inner border are much longer than on the sides and behind. They are mostly strongly ciliated supporting cells, with which are mingled glandular cells of various kinds, and large oval nematocysts with a loose internal thread. The latter are of the same form as occur more rarely in the ectoderm of the stomodæum and knobs of the tentacles.

In the stomodæal region the imperfect mesenteries are devoid of filaments; they appear, however, immediately below and completely resemble those on the chief mesenteries.

Proximally the mesenteries branch at their free termination, each branch being capped by a filament in which the large nematocysts predominate.

No gonads were present in any of the polyps examined.

On one occasion six specimens were collected at Drunkenman Cay, all closely associated within a crevice in the coral rock in shallow water; and another time several polyps were come upon living together on a live Pinna shell from Harbour Head, Kingston Harbour. When irritated they are capable of sending out quantities of clear mucus.

The species was first obtained by Duchassaing and Michelotti from St. Thomas, and described by them under the term *Draytonia myrcia*; Andres places it among his "Corynaetidae dubiae," under the genus *Corynaetis*. The correctness of this generic transference I have already referred to.

Its histological characters should be compared with those of *C. australis* (1896, pp. 152-3), and it will be seen that the two closely agree. The mesenteries are, however, more regular, and the sphincter muscle slightly better developed in the present species. The sphincter also differs from that of *C. viridis*, Allm. (1896, pl. viii., fig. 11).

The connexion of one polyp with another by a basal expansion, and the usual occurrence in groups are indicative of asexual reproduction, a method already known to occur in the British Globehorn, *C. viridis* (1860, p. 291). The irregularities in the arrangement of the mesenteries noted in *C. australis* (1896, p. 152), and in *C. hoplites* (1898, p. 468), are probably also due to this process. In the Australian representative it was found that some specimens possessed only one pair of directives, while others had two.

Attention should be directed to the tetrameral arrangement of the mesenteries, corresponding with the tetrameral tentacles; the extraordinary development of

gland cells, both in the ectoderm and endoderm is noteworthy; and also the very large, oval cnidocysts in the knobbed tentacles, stomodæal ectoderm, and mesenterial filaments. The mesogloea is an exceptionally homogeneous layer, and the retractor muscle of the mesenteries is arranged on only slight mesogloéal folds, never becoming circumscribed. Undoubtedly one of the most important anatomical features is the absence from the mesenterial filaments of any lateral lobes bearing the Flimmerstreif.

Tribe.—ZOANTHEÆ, R. Hertwig, 1882.

Family.—ZOANTHIDÆ, Dana, 1846.

Sub-family.—MACROCNEMINÆ, Haddon and Shackleton, 1891.

For the definitions of the Tribe, Family, and Sub-family, the first instalment of this series should be consulted, or better, the original papers of Haddon and Shackleton (1891, 1891*a*).

Genus.—PARAZOANTHUS, Haddon and Shackleton, 1891.

Macrocnemic Zoantheæ, with a diffuse endodermal sphincter muscle. The body-wall is incrustated. The ectoderm is continuous. Encircling sinus as well as ectodermal canals, lacunæ, and cell-islets in the mesogloea. Dioecious. Polyps connected by thin cœenchyme, rarely distinct.

The characters of greatest generic importance are the macrocnemic arrangement of the mesenteries, a feature shared with the genus *Epizoanthus*, and the presence of a diffuse endodermal sphincter muscle.

In their "Review of the British Actiniæ," Haddon and Shackleton assign to the genus three European forms; *P. axinella* (Schmidt), *P. anguicomus* (Norm.), and *P. Dixoni*, n. sp., and, in their Report on the Zoantheæ collected by Professor Haddon in Torres Straits, make an addition of two new species, *P. dichroicus* and *P. Douglasi*. In the paper on Jamaican Zoantheæ, I show that the *Gemmaria Swiftii*, of Duchassaing and Michelotti (1860), must be transferred to *Parazoanthus*, and also advert to the fact that Carlgren (1895) has demonstrated that the supposed Antipatharian genus *Gerardia*, Lac.-Duth, must probably be regarded as belonging to the same genus. Reviewing the Zoanthean genera in his latest paper, Haddon (1898, p. 408) confirms Carlgren's statements with respect to this form, and locates *Gerardia* between the genera *Parazoanthus* and *Epizoanthus*.

Recent trawling in the Caribbean Sea has brought up from the Pedro Banks distant about 50 miles south-west of Jamaica, a branching Hydroid over 100 cm. in height, the trunk and main divisions of which are entirely incrustated with a single Zoanthid colony. It bears a very close external resemblance to *Parazoanthus*

*dichroicus*, Hadd. and Shackl., but histological characters reveal that the two are quite distinct. I propose to term it *Parazoanthus tunicans*, on account of its investing habit.

Quantities of sponges were also trawled on the same occasion, many of which displayed small commensal anemones distributed over nearly their whole surface. On some massive, black sponges, two or three feet in diameter, the polyps appeared as distinct, white, circular discs, but on a dark, purplish sponge they were in small colonies, producing short catenulations.

A detailed study discloses that these two, though somewhat similar in their habit, are distinct species.

Anatomical examination leaves no doubt that the first sponge-incrusting form is a *Parazoanthus*, and I propose to term it *P. separatus*, in emphasis of the distinct character of its individual polyps. With regard to the generic position of the second, some uncertainty prevails. Owing to the remarkable shortness (0·5 mm.) of the polyps, and the presence of numerous large sponge spicules in the capitular region, I have failed to make out the arrangement of the mesenteries, or to discover any sphincter muscle.

Considering, however, the extreme weakness of the musculature in all the other parts of the polyp, and the thinness of the mesogloea in the capitulum, there can be no doubt that any sphincter occurring will conform to the type characteristic of *Parazoanthus*; and further, comparing all its external and anatomical features with those already known in other species, I have little or no hesitation in assigning the form to the present genus. I propose for it the term *Parazoanthus monostichus*, the polyps being usually arranged in a single row.

A comparative study of the different representatives of the genus calls for a few remarks of more general interest in Actinian morphology.

In respect to both its musculature and the mesenterial filaments, *Parazoanthus* displays conditions which lead one to place it as the lowest of the Zoanthean genera, a position already assigned it by Haddon and Shackleton on less conclusive grounds. Taking the mesenteries only into account Haddon considers the other sub-family—the *Brachyzeneminae*—may be regarded as slightly more primitive.

The musculature in all the species of *Parazoanthus* is weak. This is especially true of the sphincter muscle. In all other genera of the Zoantheidæ the sphincter is embedded in the mesogloea, and is usually of considerable strength; in *Zoanthus* it is even double, being subdivided into an upper and a lower portion.

The diffuse, endodermal sphincter characteristic of the genus represents merely a concentration in the capitular region of the circular endodermal muscle which lines the column, usually throughout its length.

As the sphincter becomes more strongly developed, the mesogloæal foldings



supporting it become deeper and deeper to give increased area for its support, until they may ultimately unite at their free edges, the muscle thus passing from the endodermal to the mesogloæal stage.

In *P. Swiftii*, where the general endodermal musculature and the sphincter are comparatively well developed, small portions of the latter do actually appear to become cut off from the endoderm and become wholly included within the mesogloæa (1898, pl. xx., fig. 5). The mesogloæal bays are, however, so deep as to suggest the possibility that the appearance of included muscle fibres may be merely a result of the direction in which the section is taken. Such would be the case if the depressions were deep and oblique to the plane of the section. The endodermal muscle is, of course, mesogloæal at the origin of a mesentery in the column-wall.

Concerning the sphincter of *P. dichroicus*, Haddon and Shackleton (1891 *a*, p. 699) remark:—"Near the upper extremity (in contracted specimens), it appears to become embedded in the mesogloæa, a few simple cavities being visible in our sections." We thus possess in the genus, indications, at any rate, of how the actual transference from an endodermal to a mesogloæal muscle is effected (cf. Haddon, 1898, p. 432).

The musculature is everywhere very feeble in *P. separatus*, and the sphincter certainly remains entirely endodermal. The polyps of *P. monostichus* are only about half the size of the former; and such a muscular weakness is indicated in all the organs that, independently of the interference of the incrustations, the sphincter would probably be difficult of recognition.

Two of the four Antillean species of *Parazoanthus* which I have examined, exhibit in their mesenterial filaments a simpler condition than that characteristic of other Zoanths.

The structure of the upper part of the Zoanthean filament is well known. It is trifold or V-shaped in transverse section. A middle apical portion of ciliated supporting cells, granular gland cells, and nematocysts, constitutes the glandular streak, Drüsenstreif, or Nesseldrüsenstreif; the outer layer of the two lateral components consists entirely of narrow, ciliated, supporting cells, and forms the ciliated streak or Flimmerstreif. Coming between the Flimmerstreif and Drüsenstreif on each side is a tissue more nearly resembling the ordinary endoderm, and described by Professor von Heider (1895, p. 127 and fig. 16), as the "Entodermwucherung." I do not, however, regard it as homologous with the thickening of the mesenterial endoderm immediately behind the filament in its simple form as von Heider appears to (cf. his fig. 28).

Though differing in form the Zoanthean filament accords in histological detail with that of most other Actiniaria; the "Entodermwucherung," corresponding with what I have termed the "intermediate streak."

A peculiarity connected with the Zoanthean filament is that the Flimmersstreifen extend for some distance up each face of the perfect mesenteries, just before the latter cease their connexion with the stomodæum; the middle portion is folded and in actual contact with the mesentery, while the two ends, or at any rate the centrifugal end, may hang freely in transverse sections. The whole structure has been denominated by Haddon and Shackleton (1891, p. 619), the "reflected ectoderm," these authors regarding it as representing a portion of the stomodæal ectoderm which has become transferred to the face of the mesenteries. In the adult the reflected ectoderm and mesenterial filaments are always found in absolute continuity with the ectoderm of the stomodæum. And it has also been demonstrated by M<sup>c</sup>Murrich (1891) and others, that even at an early stage in the development of the embryo such a relationship can be recognized.

While not inclined to accept the ectodermal origin of the "reflected ectoderm," or of any portion of the mesenterial filaments, the former term may be employed for the present as referring to parts now well known in Zoanthean morphology. The Hertwigs (1879) first emphasized the fact that trifoliate mesenterial filaments may appear on mesenteries of the lower orders which never reach the stomodæum, and in all their structural details are indistinguishable from those occurring on the first order; and this appears to me to militate most strongly against an ectodermal origin to any part of the Actinian filament. I regard the continuity of the strongly ciliated stomodæal ectoderm, reflected ectoderm, and the Flimmerstreifen and Drüsenstreif of the mesenterial filaments as having a physiological rather than a morphological significance, as being necessary, in fact, for the proper maintenance and regulation of the internal circulation of the respiratory and digestive fluids in the mesenterial chambers of and around the stomodæal region.

The histological characters of the tissues point to this, while the similarity of structure is not so great as is sometimes assumed. The uniform nature of the cells composing the Flimmerstreifen certainly contrasts strongly with the variety met with in the stomodæal ectoderm, with the exception of those lining the gonidial grooves. The grooves are usually more strongly ciliated, and but few glandular or stinging cells occur amongst the supporting cells.

Less differences exist between the Drüsenstreif and stomodæal ectoderm, while the Entodermwucherung shows no histological relationship with the latter.

The ciliation of the gonidial grooves, reflected ectoderm, and the Flimmersstreifen is more pronounced than that of any other region of the Actinian polyp, and usually persists in preserved specimens even when not observable elsewhere. The histological elements are also more specialized, pointing to a specialized function. The cells are almost entirely of the extremely narrow ciliated type, each with an oval-shaped nucleus, often larger in diameter than the cell itself,

and arranged at a different height in different cells in such a way that in sections they give rise to a very characteristic deeply-staining zone. Elsewhere in the polyp the association of histological elements is more varied, glandular cells or nematocyst-bearing cells mingling with supporting cells.

In two of the present species of *Parazoanthus*—*P. separatus* and *P. monostichus*—little or no reflected ectoderm is developed, and the mesenterial filaments are simple throughout, that is, only the middle lobe is present, not the lateral lobes. In longitudinal sections the ectoderm of the stomodæum is seen to be in continuity with the similarly deeply-staining tissue along the free edge of the mesenteries, but this is not continued for any distance up the faces of the latter; while transverse sections through the free edge of the mesenteries never present any structure which can be regarded as the Flimmerstreifen. *P. tunicans* exhibits on some of the mesenteries a weakly developed reflected ectoderm, and the filaments are trilobed for a very short distance below the termination of the stomodæum (Pl. xv., fig. 4).

In the figure which Haddon and Shackleton (1891, pl. lx., fig. 6) give of a transverse section through the terminal region of the stomodæum of *P. axinellæ*, the reflected ectoderm is strongly displayed, and on the free mesentery the filament exhibits the characteristic trifoliate appearance. In the genus *Parazoanthus* then every stage can be obtained in the presence or absence of the typical trifid Actinian filament, the variation evidently being dependent in some degree upon the dimensions obtained by the polyps.

The absence of the Flimmerstreifen from the mesenterial filaments is now known for several Actinaria outside the Zoantheæ, and is the condition exhibited throughout the Madreporaria, as far as these have been studied. The character must be regarded as indicative of a lower degree of Actinozoan development, and in the two species of *Parazoanthus* mentioned, may be correlated with the very diminutive size of the polyps not necessitating the same vigorous internal circulation.

Professor Haddon and Miss Shackleton draw attention to the fact that the endoderm is often implicated in the upward reflection of the lower edge of the stomodæum. It is very noticeable in *Parazoanthus axinellæ*, the appearance in which species they figure. The same condition is also to be observed in all the species of *Parazoanthus* coming under my notice, as well as in many other Actinaria and Madreporaria. In longitudinal sections it is evidenced by a strongly marked concave border to the mesentery as it leaves the stomodæum.

As the authors referred to remark, it has probably no morphological significance, and is no doubt exaggerated in a retracted state of the polyps.

The members of the genus exhibit a certain relationship in regard to the presence or absence of pigment granules and of zooxanthellæ. It is usually

noticed that where the former are present in excessive amount, the latter are absent, and *vice versa*; the two may, however, exist side by side in the same species. The granules are recognized as very small spheroidal bodies of various sizes, devoid of a nucleus and cell-wall, these being easily detected in the commensal algæ.

Most of the tissues of *P. Swiftii* are densely loaded with bright yellow granules of all sizes, but no zooxanthellæ occur. The endoderm of *P. dichroicus* is also stated to be richly pigmented, and no zooxanthellæ are seen. The converse holds in *P. tunicans*, the endoderm cells throughout contain an abundance of unicellular algæ, but pigment granules are practically absent; *P. monostichus* and *P. separatus* show an admixture of granules and zooxanthellæ. In the latter species a peculiar accumulation of brown pigment granules is found in the endoderm, about midway along the width of the mesenteries, this being the only occurrence in the polyp.

Similar relationships of granules and zooxanthellæ are afforded by other families of Actiniaria. According to my observations pigment granules only are present in *Bunodes granulifera* and *B. Krebsii*, while they are replaced by zooxanthellæ in *Aulactinia stelloides*. Most Sagartidæ contain zooxanthellæ, but in *Sagartia nivea* (Verrill), the substitution of granules has occurred. The latter condition is also the case in *Actinoporus elegans* and in *Corynactis myrcia* already referred to.

It seems likely that in some cases the pigment granules may perform the same function as the commensal algæ—that of respiration. If this be so, we may perhaps regard them as free chromo-plasts, aggregated in the other case within distinct cells, the zooxanthellæ.

Although the amount and relative proportion of the inclusions vary, yet a curious similarity in their nature holds throughout the genus. Fine sand-grains and siliceous sponge spicules, with an occasional Radiolarian and Foraminiferal test, are characteristic of each species. Carlgren found much the same in *Gerardia*.

Haddon and Shackleton note the inclusions to be fairly numerous in *P. anguicomus*, and less so in *P. azinellæ* and *P. dixonii*. Calcareous sand-grains predominate in *P. tunicans*, and sponge spicules in *P. monostichus*, while both are numerous in *P. separatus*. In the two latter the majority of the spicules are similar to those of the sponge with which the anemone is commensal.

A certain selection in the disposition of the foreign inclusions is also observable. Practically all the calcareous sand-grains of *P. tunicans* are limited to a narrow zone around the boundary of the ectoderm and mesogloæ; while the sponge spicules are distributed throughout the middle layer, extending even to its inner boundary (Pls. XIII. and XIV., fig. 4). Further, the spicules are most numerous in the capitular

region, as is also the case with the two other species, rendering suitable sections in this region difficult to prepare. As the sponge spicules are very long in *P. monostichus*, much longer in fact than the thickness of the capitular wall, they are of necessity disposed in a regular circular series, very obvious in thick transverse sections (Pl. XIII., fig. 9).

The outer part of the column-wall of *P. Swiftii* is loaded with inclusions, but none extend beyond the encircling sinus. The mesogloea there becomes extremely homogeneous in structure, an included cell even occurring but rarely. Such a strongly marked division of the mesogloea into two parts—an outer, containing the inclusions, canals, cell-islets, etc., and an inner, practically homogeneous in nature and separated from the former by the encircling sinus—appears to be more or less general throughout the genus.

The size of the colonies and the extent to which the cœnenchyme is developed are likewise features of some importance. The simplest stage is exemplified by *P. separatus*, where each polyp is distinct and surrounded by only the merest trace of cœnenchyme. To include this exceptional instance, I have slightly added to the previous definitions of the genus. The few polyps in any colony of *P. monostichus* also afford but a bare indication of connecting cœnenchyme; while in a colony of *P. tunicans* or *P. dichroicus*, hundreds of polyps are, as it were, inserted in a common incrusting cœnenchyme. *P. Swiftii* is somewhat intermediate in the dimensions attained by its colonies and the amount of cœnenchyme produced. A few polyps only constitute a distinct colony, each arising from a clearly separable, though very limited, cœnenchyme.

The species I have examined, support the experience of Haddon and Shackleton (1891, p. 623), that “all the members of a single colony of dioecious Zoantheæ belong to the same sex.” All the numerous polyps of *P. Swiftii* and *P. tunicans* sectionized were crowded with ova. It seems remarkable that of very many examples of *P. separatus* and *P. monostichus*, microscopically examined, none showed any trace of reproductive cells.

#### **Parazoanthus tunicans, n. sp.**

(Pl. x., fig. 11; Pl. XIII., fig. 7; Pl. xv., figs. 4, 5.)

Each colony consists of a thin cœnenchyme from which numerous polyps arise at short distances apart, the whole completely incrusting the main stems and smaller branches of a large Plumularia. On the smaller branches the polyps are arranged in a distichous manner, in a plane at right angles to that of the pinnulæ of the Hydroid, and the polyps on the two sides are either opposite or alternate. On the thicker stems their distribution becomes more irregular, and the polyps extend all round; they often arise obliquely to the surface of the cœnenchyme.

To the naked eye the surface of the cœnenchyme and column-wall is quite smooth, but with a lens minute white granulations—the foreign inclusions—are disclosed. The walls are thick and firm, but in some cases superficial wrinklings may be observed in preserved specimens.

The polyps were examined only in their retracted or partly retracted state. They are capable of complete retraction, in which condition they are usually mammiform; or they may be slightly longer, and flattened or rounded above, a small aperture remaining in the middle. Towards the base the column enlarges in diameter, especially in the most retracted individuals.

The capitular ridges are small, and can be distinguished and counted only with the assistance of a lens; they are wedge-shaped and acute, and vary in number from 14 to 16. The ridges and furrows are most distinctly indicated during partial extension.

The tentacles are short, apparently rounded at their apex, and dicyclic, fourteen to sixteen occurring in each cycle. The mouth is rounded or slit-like, and the lips prominent.

The colour of the cœnosarc and column-wall is greyish, being determined by that of the included particles; the tips of the capitular ridges are a little lighter; the tentacles and disc are brown.

The height of retracted polyps above the cœnenchyme is about 2 mm., and the diameter the same.

#### ANATOMY AND HISTOLOGY.

The ectoderm of the column-wall is a continuous layer, that is, it is not broken up by crossing strands of mesogloea, as is the case in many Zoanthæ. Superficially, it is devoid of any recognizable cuticle or sub-cuticle, and the constituent cells are more rounded than columnar in outline. The internal limitations of the layer are very irregular and indeterminate in places, most of the inclusions occurring around its boundary with the mesogloea, while cells pass from it into the mesogloea (Pl. XIII., fig. 7; Pl. xv., fig. 4).

Small colourless nematocysts occur, but are not very numerous.

The mesogloea is moderately thick, and near its internal border contains a narrow, interrupted, encircling sinus filled with cells closely resembling those of the ectoderm; in the distal region, where the sinus becomes broader, it includes numerous nematocysts.

Isolated cells and cell-islets are scattered throughout the mesogloea; and a few siliceous sponge spicules are included, in addition to the predominating calcareous sand-grains. The latter are very small and practically limited to its peripheral border; they are dissolved out by acids leaving only irregularly-shaped lacunæ. In regard to the foreign inclusions, a decided selection is manifested in

that the calcareous incrustations are limited towards the periphery of the wall, while the siliceous sponge spicules and a few Radiolarian tests are more internal and more distal.

The endoderm cells are loaded with zooxanthellæ. Proximally there is only a faint indication of an endodermal circular musculature, but towards the apical region the fibres become stronger and more concentrated, and constitute a weak, diffuse, endodermal sphincter muscle, the mesogloea forming deep, closely-arranged bays for its reception. No part of the muscle, however, becomes actually enclosed in mesogloea, except at the places where the mesogloea of the mesenteries is united with that of the column-wall (Pl. XIII., fig. 7).

The cœnosare surrounding the Hydroid stem, and connecting one polyp with another, contains inclusions similar to those of the column-wall. Irregular channels with a thick lining of endoderm serve as a means of communication between the cœlenteron of one polyp and another. In sections the Hydroid stem is completely embedded in mesogloea; this latter also contains abundant cells and cell-islets.

The ectoderm of the tentacles discloses a peripheral zone of small, narrow nematocysts throughout its length. The mesogloea is thin and very slightly plaited for the support of a weak ectodermal and endodermal musculature, and a nervous layer connected with the former is distinguishable. The endoderm is loaded with zooxanthellæ, and completely fills the lumen in contracted tentacles.

The disc is extremely thin-walled, but becomes a little thicker near the tentacular region, where nematocysts and gland cells occur.

The stomodæum is of small vertical extent. A single gonidial groove is indicated, very shallow in some examples and deeper in others, while the walls rarely display any vertical folding. The ectoderm is constituted of the usual ciliated supporting cells, granular gland cells, and but few nematocysts; in the region of the groove, glandular cells are very scarce. An ectodermal and endodermal musculature can be made out, though but feebly developed; an ectodermal nervous layer is also displayed. The mesogloea is much thinner than the ectoderm, and undergoes no additional thickening at the groove. The endoderm is broad, and its cells contain many zooxanthellæ.

At its lower termination the wall of the stomodæum is backwardly and outwardly directed for a short distance; and the ectoderm is in continuity with the tissue of almost exactly similar nature which runs radially along the edge of the perfect mesenteries, and, as the "Reflected ectoderm," passes for a very short distance up each face of the perfect mesenteries.

The reflected ectoderm is not developed to the same extent on all the mesenteries, and very rarely presents a similar appearance on the two faces of the same mesentery. It is constituted of extremely narrow ciliated supporting cells,

the oval nuclei of which are arranged at different heights in the different cells, so that a distinct, deeply-staining, nuclear zone is produced in sections (Pl. xv., fig. 4).

In transverse sections, a little above the stomodæal termination, the reflected ectoderm is thrown into a few short vertical folds, and centrifugally is free from the mesentery, while centripetally it can be traced in continuity with the ectoderm of the stomodæum.

This continuity is, however, not one of exactly similar tissues throughout, but is interrupted at places by a tissue of a different nature. The cell nuclei of this are rounded, and not arranged in a distinct zone, and the whole stains less deeply and contains zooxanthellæ and granular gland cells. To this tissue, as met with in *Zoanthus chierchia*, von Heider (1895, p. 129) has applied the term *Drüsenwulst*." Though its presence can be easily recognized in *P. tunicans*, it is not so well developed as in the genus *Zoanthus*, where, owing to the increased size and length of the polyps, the reflected ectoderm and mesenterial filaments are better displayed and more favourable for study.

As shown in Pl. xv., fig. 4, a filament is a complex structure, the sagittate or lanceolate form in transverse sections being characteristic of the *Zoanthææ*. The outer border of the lateral lobes is constituted of ciliated, extremely narrow cells, the associated nuclei forming a very regular, densely-staining zone. It is to this tissue that I consider the term ciliated streak or *Flimmerstreif* should be restricted, and not applied to the lateral lobe as a whole, as is usually done. The inner layer of the lobes is formed of endoderm cells, indistinguishable from the epithelium of the mesentery. The tissue occurring around the termination of the middle lobe is made up of ciliated supporting cells, granular gland cells, and nematocysts. The term glandular streak, *Drüsenstreif*, or *Nesseldrüsenstreif* should, in my opinion, be employed only for this part of the middle lobe, the intermediate streak coming between it and the ciliated streak. Towards its termination the mesogloea is slightly swollen, and delicate muscular fibres border it anteriorly.

The mesenteries exhibit the macrocnemic arrangement, that is, the dorsal, or sulcular pair of imperfect directives has a pair of mesenteries on each side—of which the first is a perfect mesentery, and the other an imperfect—and the succeeding pair consists of two perfect mesenteries (Pl. xv., fig. 4). Beyond these the pairs consist of an imperfect and a perfect mesentery until the neighbourhood of the ventral or sulcar directives is reached, when the arrangement in pairs becomes a little irregular, this being the region in which new mesenteries are added. In one polyp eight perfect mesenteries occurred on each side, while in another eight were present on the left and six on the right side.

The mesenterial musculature is extremely feeble, and the parieto-basilar is clearly distinguishable. The mesogloea is broad at its origin in the column-wall,



but narrows rapidly beyond. A very short basal canal and several cell-islets occur in the expanded portion. The mesenterial endoderm is broad and loaded with zooxanthellæ; nematocysts also occur sparingly.

Male gonads were present in all the numerous polyps sectionized from the one colony. The surrounding mesenterial epithelium is enormously thickened and the ripe spermata are enclosed in the very thin mesogloea. Around their margin are the deeply-staining sperm mother-cells; filling the greater part of the interior are the heads of the ripe spermatozoa, while towards one side are aggregated the tails of the spermatozoa (Pl. xv., fig. 5).

One very large, much-branched colony was trawled from a depth of 10–14 fathoms on the Pedro Bank, 11th April, 1898, incrusting an aborescent *Plumularia*, as much as 100 cm. high. The cœnenchyme was continuous nearly throughout the surface of the Hydroid, only the smallest terminations being free.

Apparently no Zoanthid at all resembling this form has been described from Antillean waters, nor as a member of the nearly related Actiniarian fauna on the western coast of Central and South America.

In habit and external features it compares most closely with *Parazoanthus dichroicus*, Hadd. and Shack. (1891, p. 698), obtained by Prof. Haddon from Torres Straits, incrusting a specimen of *Plumularia ramsayi*. It thus forms another instance of the strong relationship, particularly in the Zoantheæ, which is being established between the Actinaria of the Australian and Caribbean seas.

The capitular ridges in *P. dichroicus* are about eighteen, an increase of two or three beyond the number prevailing in *P. tunicans*.

I have never observed any dichroic effect given to the alcohol from preserved material, a peculiarity emphasized in the specific name of the former. Histologically important differences are indicated, which leave no doubt as to the distinctness of the two species.

The incrusting particles of sand are siliceous in the older species and calcareous in the new; the encircling sinus is filled with dark-brown granular pigment in the one, but not in the other. The latter distinction is associated with the absence of zooxanthellæ in the pigmented form, while they are abundant in *P. tunicans*, which, conversely, is devoid of pigment. The mesenterial musculature is less developed in the last-mentioned species.

External characters alone readily separate it from all other known species of *Parazoanthus*.

***Parazoanthus separatus*, n. sp.**

(Pl. x., figs. 12, 13; Pl. xiii., fig. 8; Pl. xiv., fig. 4.)

In their retracted condition the isolated polyps present themselves as small,

circular, light-coloured discs, or low mammiform prominences, distributed with considerable regularity over the surface of massive, dark-coloured sponges. What may be regarded as a very narrow border of cœnenchyme surrounds each individual polyp. Only occasionally are two or more polyps still united as a result of reproduction by budding, and all stages in the separation of one from the other can be observed. A thin cœnenchyme connects two polyps before their isolation, but chain-like colonies are never produced, as in the next species. The column-wall is smooth, but with a lens, minute, white, incrusting granulations are seen. These give a certain rigidity to the polyps, so much so that, in preserved material, the walls readily split in two.

Retraction is complete in most examples; only a very small circular depression remains above, not sufficiently large to allow the mouth or disc to be seen. The capitular ridges are wedge-shaped, and number from twelve to sixteen, twelve being the most usual. The tentacles are extremely short, and, as seen in sections, are almost invariably twenty-four, arranged in two cycles. The disc is circular and semi-transparent, and exhibits radiating grooves corresponding with the internal attachment of the mesenteries. The peristome is raised, the mouth slit-like.

The cœnenchyme and column are dull white, due to the numerous included calcareous sand-grains; the tentacles and disc are dark brown.

The diameter of retracted polyps is about 2·5 mm., the height 1·5 mm.

#### ANATOMY AND HISTOLOGY.

All that portion of the wall of the polyp which is embedded in the sponge may be regarded as the base, and discloses a different histological character from that of the free column-wall. It is convex in outline, but somewhat flattened and expanding peripherally, and is sharply marked off from the surrounding sponge tissue, showing that there is no intimate cellular relationship between the two. A very thin cuticle can also be traced (Pl. XIV., fig. 4).

The ectoderm in places is not readily distinguishable from the mesogloea, the latter layer being so crowded with cells as to render the ground substance almost unrecognizable (Pl. XIII., fig. 8). The ectodermal cells are large and more or less spherical in outline, not forming a columnar epithelium; their protoplasm stains very strongly.

The mesogloea is broad, and, as a whole, stains very deeply, the result of the presence of the cellular constituents, mostly in the form of cell-islets. Cells are included to an extent greater than I have met with in any other Actinian; they are all large, and the cytoplasm, in addition to the nucleus, readily takes up

any stain. The matrix is scarcely discernible except at the inner border, where it may sometimes be observed in connexion with a mesentery. Sponge spicules are present in both the ectoderm and mesogloea, though not to the same extent as might have been expected from the nature of the commensalism. Lacunae also occur in decalcified specimens, indicating where calcareous sand-grains had been included. The endoderm is a broad layer, crowded with zooxanthellae. No basal musculature has been detected.

At the boundary of the base and column occurs an expansion of the wall, there being, as noticed amongst the external characters, a slight formation of coenenchyme (Pl. xiv., fig. 4).

The ectoderm of the column-wall is a broad continuous layer, the columnar character of the cells not being clearly indicated in sections. Its internal limits are ill-defined, partly owing to the foreign inclusions tending to break up the layer, and also to the fact that abundant cells pass from it into the mesogloea. A small oval nematocyst, which does not stain, is scattered sparingly and irregularly throughout.

The mesogloea contains small, rounded or elongated cells with granular protoplasm, and also cell-islets, not, however, to the same extent as in the mesogloea of the base. Towards its internal border a very irregular, narrow, encircling sinus occurs, and beyond this it is much more homogeneous. Owing to the strongly cellular nature of the outer region of the mesogloea the encircling sinus is not so distinct as in most of the species investigated by Haddon and Shackleton, nor as in *P. tunicans*, where the mesogloéal matrix is much more uniform. The cells included in the sinus possess very granular protoplasm, and abundant nematocysts similar to those in the ectoderm; these latter are particularly numerous in the distal region of the polyps.

Numerous cellular connexions can be traced between the irregular internal limits of the ectoderm and those of the encircling sinus.

The whole mesogloéal layer contains foreign inclusions, more abundant, however, peripherally; they are mainly calcareous sand-grains which are dissolved out by acids. Silicious sponge spicules are particularly abundant in the upper region of the column, and always remain in microscopic preparations. The sand-grains are more restricted in their distribution to the region of contact of the ectoderm and mesogloea.

The endoderm of the column-wall resembles that of the base, but above is much thickened between the mesenteries, while it is narrow below. An extremely weak, endodermal musculature extends the whole length of the column. At the capitulum, the mesogloea becomes sinuous in sections, and the muscle fibres are here a little stronger and represent the sphincter muscle (Pl. xiv., fig. 4).

The sphincter is of a diffuse endodermal character; the mesogloéal folds

are rather narrow and deep, but the presence of numerous sponge spicules interferes with a detailed study. As noticed amongst the external characters the polyps are capable of excessive retraction, so much so as to obliterate a great part of the cœlenteric space, and produce a great displacement of the disc and stomodæal walls.

The ectoderm of the tentacles presents throughout its extent a peripheral layer of small, narrow nematocysts, differing from the oval form in the column-wall. Below this nematocyst layer a nuclear zone is usually separable from the more internal nervous and muscular elements. An ectodermal and an endodermal musculature are developed; the former much the stronger. The layer of nerve fibrils is often distinguishable in connexion with the ectoderm. The mesoglaea is very thin, but a little better developed proximally; it is finely plaited for the support of the ectodermal musculature.

The endoderm contains zooxanthellæ, and very often fine pigment granules; these latter are also found in the ectoderm. Spicules occur in some abundance in the tentacular tissues, somewhat more numerous in the outer than in the inner cycle. Though such a position for inclusions is exceptional they are met with in all the examples studied, and in such a manner as to leave little doubt that they are not the result of displacement during the preparation of the sections.

The disc is very thin, and peripherally closely resembles the tentacles in structure; a few nematocysts occur in the ectoderm, as well as numerous deeply-staining granular gland cells.

The vertical height of the stomodæum is remarkably small in contracted specimens (Pl. xiv., fig. 4); and in a series of transverse sections the sulcar end terminates in advance of the sulcular. The single gonidial groove is clearly indicated. In transverse sections the wall is usually cut through twice as a consequence of the partial reflection of the internal termination of the stomodæum. As seen in the figure, the stomodæal wall passes slightly upwards and outwards for a considerable distance. The ectoderm displays the usual histological structure, consisting mainly of ciliated supporting cells, the combined nuclei of which give rise to a very distinct zone; granular gland cells, which also stain deeply, are abundant, especially in the upper regions, but nematocysts do not appear to be developed. No ectodermal musculature is discernible over any part of the stomodæum. The mesoglaea is very thin, and undergoes no appreciable thickening at the groove. In vertical sections the stomodæal ectoderm is in continuity with the mesenterial filaments; but there is no special formation of reflected ectoderm.

Owing to the extreme retraction and the shortness of the stomodæum, some difficulty is experienced in making out the arrangement of the mesenteries; but

out of numerous examples sectionized, I have been able to definitely ascertain the macrocemic arrangement in several.

The mesenteries below the stomodæum are very short in transverse sections, and extend but a little distance vertically; two or three are continued for some way below the others, but which are in relation to the directives could not be determined. As the free edge of the mesentery leaves the stomodæum it becomes deeply concave. Owing to this, and the shortness of the stomodæum, the perfect mesenteries in transverse sections of some retracted polyps appear free even before the stomodæum is reached, one half being still connected with the concave disc, and the other with the column-wall, each with the filamental tissue at its free termination.

The endodermal epithelium of the mesenteries resembles that of the body-wall, and contains many zooxanthellæ.

In the upper region of the polyps, the mesenterial mesogloea as it leaves the column-wall is much and irregularly thickened, and contains cell-islets, but beyond this the layer is extremely thin. There is a distinct indication of a parieto-basilar muscle on each side, but the longitudinal musculature is not sufficiently developed to allow of a study of the paired arrangement of the mesenteries being made.

No reflected ectoderm occurs on any of the mesenteries. In transverse sections around the termination of the stomodæum an appearance of such is presented, but it is merely the Drüsenstreif which here runs horizontally. The tissue is never folded, as is usually the case, with the reflected ectoderm, while granular cells and nematocysts are present in addition to the supporting cells. Vertical sections also reveal a similar absence.

For some little distance from their origin at the stomodæum, the filaments in section have an irregular outline. They are simple throughout their length, consisting only of the middle lobe or Drüsenstreif. In the lowermost region the mesenteries may divide at their free edge into three branches, each capped by a filament which is cordate in transverse section. The latter is sharply cut off from the rest of the mesentery, and stains much more deeply. The mesenterial endoderm is usually thickened immediately behind the filament, in some cases partly surrounding the filament; otherwise it differs in no important respect from the remaining mesenterial epithelium.

No gonads were present in any of the numerous examples sectionized.

The form described above was trawled on several occasions from a depth of 10–14 fathoms on the Pedro Banks, Caribbean Sea, embedded in the superficial tissues of some massive, dark-coloured sponges. From the number of sponges trawled, each bearing the commensal Zoanthid, the species must be very abundant

in these regions. The individual polyps are closely scattered over the whole superficial area of the sponge, and are arranged with considerable regularity as regards distance apart. They are generally a little closer and less regular in the lower region of the sponge, where growth cannot be proceeding so rapidly as more distally. Numerous small pores are distributed over the sponge, and in most of these a commensal *Alphæus* was found.

I have hesitated for some time as to whether the form can be referred to any of the known Antillean sponge-incrusting species. The one most likely is *Zoanthus parasiticus*, D. & M., in which the polyps are isolated.

This is, however, stated to be a veritable *Zoanthus* with fleshy walls, not hardened by fleshy inclusions. Under these circumstances I think it is best to regard the species as distinct, awaiting further discoveries to indicate the true nature of the *Zoanthus*. The Caribbean Sea is obviously very rich in examples of anemones commensal with sponges, but this and the next described species, along with *P. Swiftii*, are readily distinguished both externally and anatomically.

**Parazoanthus monostichus**, n. sp.

(Pl. x., fig. 14 ; Pl. XIII., fig. 9.)

The polyps give rise to extremely small colonies embedded in the superficial tissues of a dark purplish sponge, over the whole of which they are distributed with considerable regularity. In the retracted condition of the polyps, the colonies appear as minute, light-coloured catenulations, contrasting strongly against the dark sponge. From two to seven or eight individual polyps are associated in a single row, but sometimes one or two may be produced laterally, and so give rise to an irregularly-shaped colony. Rarely the polyps are isolated. An extremely narrow border of cœnenchyme surrounds each colony or individual. Multiplication takes place by budding, and the individuals are often so closely contiguous that no intervening cœnenchyme is apparent. All stages in the separation of one polyp from another can be observed, the cœnenchyme becoming drawn out more and more until the constriction breaks down. In retraction the polyps are flattened and scarcely raised above the general surface of the sponge. They appear to be incapable of complete retraction ; the capitulum is always fully visible, and a wide apical aperture remains in most, so that the mouth and central part of the disc are exposed. The capitular ridges are wedge-shaped, and number about 10. The surface is smooth, but minute, opaque white particles are embedded in the capitular region.

The polyps have been observed only in the semi-retracted condition, so that no details of the external appearance of the tentacles and disc can be added. The mouth is slightly oval.

In preserved specimens the cœnenchyme and column are a dull white, due to the included particles.

The diameter of the retracted polyp is about 1 mm., and the height 0·5 mm. The species is probably the smallest Actinian known.

#### ANATOMY AND HISTOLOGY.

Owing to the exceptional smallness of the polyps and the inclusion of numerous large, silicious, sponge spicules, the anatomical study of the species is carried out under considerable difficulties, and characters of fundamental importance, such as the arrangement of the mesenteries and the nature of the sphincter muscle, remain in some uncertainty.

The ectoderm of the base is in contact with the tissues of the sponge on the one hand, and on the other is scarcely distinguishable from the outer part of the mesoglœa, numbers of its cells passing into the latter. The individual cells are not disposed to form a columnar epithelium, as is usually the case, but are rounded or irregular in shape, and both the nucleus and the cytoplasm stain deeply.

The mesoglœa is divisible into two portions: an outer, broader part, much broken up by sinuses and cell-islets; and an inner, narrow, limiting part, more uniform in structure, and thickening along the line of attachment of the mesenteries. The former broadens much in some regions, and the large individual cells of the cell-islets, all with deeply-staining contents, become more distinct from one another. The endoderm is a somewhat thick layer, and contains abundant zooxanthellæ.

The outline of the base is convex, and in vertical sections across the length of the colonies the proximal region of the wall of the polyp is a little expanded laterally, constituting a narrow cœnenchyme. The mesoglœal layer here becomes thickened, and many silicious sponge spicules are included.

Large, perfect sponge spicules, arranged very closely in a circular manner, are particularly numerous in the capitular region of the column-wall (Pl. XIII., fig. 9), while calcareous sand-grains are scarce.

The ectoderm of the column-wall is a layer of non-columnar cells, and medium-sized, colourless, oval nematocysts are abundant, especially in the more distal regions. A cuticle is also observable. The internal limitations of the ectoderm are irregular, the layer passing more or less insensibly into the mesoglœa. The latter is so crowded with cells, that it stains nearly as deeply as the ectoderm. Large cell-containing spaces, connected with the ectoderm, probably represent the encircling sinus characteristic of the genus, and met with in the two previous species, but, owing to the numerous inclusions, it is impossible to make out the

relations of one cavity to another. More internal than these cell-spaces the mesogloea is practically homogeneous, and affords a sharp boundary line with the endoderm.

The endoderm is broad and contains numerous zooxanthellæ; its cells are much elongated in the narrow mesenterial spaces. Only faint indications of an endodermal circular musculature can be made out. It is unfortunate that in the capitular region, where the sphincter muscle should occur, the walls are so thin and the large sponge spicules so closely aggregated, as to render suitable sections a matter of practical impossibility. The delicate walls in every case readily break away with the inclusions.

From a knowledge of related forms it can, I think, be safely inferred that if a sphincter is developed it will be of an endodermal, diffuse, and extremely weak type. The power of retraction is not possessed to the same degree as in the previous species.

The ectoderm of the tentacles is a broad, columnar layer; small, narrow nematocysts occur peripherally, and occasionally one of the larger oval forms similar to those in the column-wall. The merest traces of an ectodermal and also of an endodermal musculature can be detected. The mesogloea is extremely narrow; the endoderm is loaded with zooxanthellæ and with deeply-staining granules of various sizes, and, in retracted examples, completely fills the lumen.

The disc in all its three layers is a very thin structure. In retracted specimens it is deeply concave outwardly, affording space above for the tentacles, while below it comes almost in contact with the floor of the coelenteron, nearly obliterating the coelenteric cavity. In consequence of the extreme shortness of the polyps as a whole, and of this approximation of the disc and base, the study of the paired arrangement of the mesenteries is almost fruitless.

The peristome remains elevated, and the stomodæum is comparatively large in sections. As shown in Pl. XIII., fig. 9, transverse sections pass at the same time through the column-wall, tentacles, elevated peristome, and stomodæum; only exceptionally can a mesentery be traced from the column-wall to the stomodæum.

The stomodæum is usually oval-shaped in transverse sections, and the single gonidial groove is clearly indicated; the lateral walls may be thrown into a few vertical folds. The ectodermal epithelium consists mainly of ciliated supporting cells with nematocysts and gland cells; the two latter are practically absent at the sulcar end where the groove occurs. Large granular gland cells, the contents of which do not stain in borax carmine, are also met with. The mesogloea is a very thin layer, thickening somewhat at the groove; the endoderm is broad and crowded with zooxanthellæ.

In vertical sections the stomodæal ectoderm is seen to be in continuity with the filamental tissue of the mesenteries. The lower termination of the stomodæum is



folded backwardly and outwardly, so that in transverse sections through this region its endoderm and ectoderm are cut through twice; and, further, the ectoderm appears to be continued radially for some distance along the mesenteries. The mesenterial filaments are, however, simple throughout, that is, only the middle lobe is present, the lateral lobes with the Flimmerstreifen not being developed.

Although numerous polyps have been sectionized, it has been found impossible to make out the complete arrangement of the mesenteries. In most ten mesenteries are perfect, being united with the stomodæum at varying intervals. Nine perfect mesenteries occurred in one example. No certain indications of imperfect mesenteries were afforded. The mesogloea of the mesenteries is swollen at its origin in the column-wall and encloses cell-islets; beyond the origin it thins rapidly. An extremely weak parieto-basilar musculature occurs. The retractor muscle fibres of the mesenteries are similarly very feeble, the mesogloea being slightly plaited to give increased support; the fibres appear to be strongest about the middle of the width of the mesentery. The mesenterial endoderm is broad and crowded with zooxanthellæ; it is more swollen below, and contains an abundance of small, spherical, apparently non-nucleated bodies, which stain deeply. Pigment granules are practically absent, but about the middle of transverse sections of mesenteries a peculiar accumulation of fine, yellowish brown granules occurs on each face, very limited in its radial extent. The endoderm throughout the polyps occasionally contains large zooxanthellæ-like bodies with a highly refractive cell-wall. No gonads were indicated in any of the polyps sectionized.

The species was trawled on only one occasion, February 10, 1898, at a depth of 10–14 fathoms, on the Pedro Bank, Caribbean Sea, commensal with a silicious sponge.

In a list of the Actiniaria around Jamaica (1898*a*), I identified the form as the much debated *Bergia catenularis*, Duch. & Mich., its commensal habit and very decided catenulariform appearance suggesting this species most forcibly. I am now convinced, however, that the safest course is, for the present, to regard it as a new species and await the possibility of discovering others which may approach the older species more closely. Especially may this be the case in regard to the nature of the cœnenchyme connecting the individual polyp. From Duchassaing and Michelotti's figure, *B. catenularis* appears to have this better developed than in the present species, and more in the form of stolons, but I do not attach much importance to the statement that the connexions arise from the upper part of the polyps. This is probably merely a result of the colonies being partly embedded in the sponge, and *P. monostichus* affords indications of the same feature. There is little doubt that the two species of *Bergia* will, when rediscovered and sectionized, be found to belong to the genus *Parazoanthus*.

It is evident that we have in West Indian waters many species of small Zoanths commensal with sponges; and, where such very few external characters are available for diagnostic purposes, their identification with previously described forms must be a matter of some uncertainty, unless one has the actual types or a number of the different species for comparison. When this can be done it will be found much easier to unite supposed new forms with the older than to rectify the confusion of synonymy.

Now that a few more representatives of these commensal anemones are available for comparison the present species appears to agree more closely with Duchassaing and Michelotti's *Gemmaria Swiftii* than does the form I identified as such in the former paper on the Jamaican Zoantheæ.

---

#### REFERENCES.

1767. ELLIS, J. :  
 "An account of the *Actinia sociata*, etc."—Phil. Trans., vol. lvii.
1786. ELLIS, J., and SOLANDER, D. :  
 "The Natural History of many curious and uncommon Zoophytes collected from various parts of the Globe."—London.
1788. GÆLLEN, J. F. :  
 In Linnæus' "Systema naturæ."—Edit. xiii., Lipsiæ.
1817. LESNEUR, C. A. :  
 "Observations on several species of the genus *Actinia*. Illustrated by figures."—Jour. Acad. Nat. Sci., Philadelphia, vol. i., pp. 169-189.
1834. EHRENBURG, C. G. :  
 "Die Korallthiere des Rothen meeres."—Berlin.
1846. DANA, J. D. :  
 "Report on Zoophytes."—U. S. Explor. Exped., 1838-1842.—Philadelphia.
1846. ALLMAN, G. :  
 "Description of a new genus of Helianthoid Zoophytes (*Corynactis*)."—Ann. Mag. Nat. Hist., vol. xvii.
1847. JOHNSTON, G. :  
 "A History of British Zoophytes," 2nd Edit.—London.
1850. DUCHASSAING, P. :  
 "Animaux Radières des Antilles."—Paris.
1857. MILNE-EDWARDS, H. :  
 "Histoire Naturelle des Coralliaires or Polypes proprement dits," vol. i.—Paris.
1860. GOSSE, P. H. :  
 "Actinologia Britannica. A History of the British Sea-Anemones and Corals."—London.

1860. DUCHASSAING, P., ET MICHELOTTI, J. :  
 "Mémoire sur les Coralliaires des Antilles."—Mem. Reale Accad. Sci. Turin, Ser. II.,  
 Tom. XIX.
1866. DUCHASSAING, P., ET MICHELOTTI, J. :  
 "Supplément au Mémoire sur les Coralliaires des Antilles."—Mem. Reale Accad. Sci. Turin,  
 Ser. II., Tom. XXIII.
1869. VERRILL, A. E. :  
 "Notes on Radiata. Review of the Corals and Polyps of the West Coast of America."—  
 Trans. Connect. Acad., vol. i., 1868-1870.
1877. KLUNZINGER, C. B. :  
 "Die Korallthiere des Rothen Meers. Theil I., Die Aleyonarien und Malacodermen."—Berlin.
1877. MOSELEY, H. N. :  
 "On new forms of Actiniaria dredged in the deep sea; with a description of certain Pelagic  
 surface swimming species."—Trans. Linn. Soc., 2 ser. Zool., vol. i.
1879. HEETWIG, O. u. R. :  
 "Die Actinien anatomisch und histologisch mit besonderer Berücksichtigung des Nerven-  
 muskelsystems untersucht."—Jena.
1882. HEETWIG, R. :  
 "Report on the Actiniaria dredged by H. M. S. 'Challenger' during the years 1873-1876."  
 —Zoology, vol. vi.
1883. ANDRES, A. :  
 "Le Actinie."—Atti. R. Accad. dei Lincei, ser. 3a, vol. XIV. (also in "Fauna u. Flora d.  
 Golfes v. Neapel," ix., Leipzig, 1884).
1888. HEETWIG, R. :  
 "Report on the Actiniaria dredged by H. M. S. 'Challenger' during the years 1873-1876."—  
 Supplement. Zoology, vol. XXVI.
1889. M<sup>c</sup>MURRICH, J. P. :  
 "The Actiniaria of the Bahama Islands, W. I."—Journ. Morphol., vol. III., No. 1.
- 1889 a. M<sup>c</sup>MURRICH, J. P. :  
 "A contribution to the Actinology of the Bermudas."—Proc. Acad. Nat. Sci., Philadelphia.
1890. MITCHELL, P. C. :  
 "*Thelaceros rhizophoræ*, n. g. et n. sp., an Actinian from Celebes." Quar. Jour. Micr. Sci.,  
 (N.S.), vol. XXX.
1891. M<sup>c</sup>MURRICH, J. P. :  
 "Contributions on the Morphology of the Actinozoa. II. On the development of the  
 Hexactiniae."—Jour. Morph., vol. IV., No. 3.
1891. CARLGREN, O. :  
 "*Protanthea simplex*, n. gen. n. sp., eine eigentümliche Actinie, Vorl. Mitteilung." Öfversigt  
 Kongl. vet.-Akademiens Förl., No. 2.
1891. HADDON, A. C., and SHACKLETON, ALICE M. :  
 "A Revision of the British Actiniae. Part II. : Zoantheæ."—Trans. Roy. Dublin Soc., vol. IV.  
 (ser. II.).

- 1891a. HADDON, A. C., and SHACKLETON, ALICE M. :  
 "Reports on the Zoological Collections made in Torres Straits by Prof. A. C. Haddon, 1888-1889. Actiniæ: I. Zoanthæ."—Trans. Roy. Dublin Soc., vol. iv. (ser. II.).
1892. SIMON, J. A. :  
 "Ein Beitrag zur Anatomie und Systematik der Hexactinien. Inaug. Dissertation."—München.
1893. M<sup>c</sup>MURRICH, J. P. :  
 "Report on the Actiniæ collected by the U. S. Fish. Commission Steamer 'Albatross' during the winter of 1887-1888."—Proc. U. S. National Mus., vol. xvi.
1893. CARLGREN, O. :  
 "Studien über Nordische Actinien, I."—Kongl. Svenska vet.-Akademiens Handl., Bd. 25.
1893. SAVILLE-KENT, W. :  
 "The Great Barrier Reef of Australia."—London.
1893. CARLGREN, O. :  
 "Ueber die Gattung *Gerardia*, Lac.-Duth."—Ofversigt af Kongl. Vet.-Akademiens Förhandlingar, No. 5.
1895. VON HEIDER, A. R. :  
 "Zoanthus chierchiæ, n. sp."—Arbeit. Zool. Inst. Graz., v.
1896. M<sup>c</sup>MURRICH, J. P. :  
 "Notes on some Actinians from the Bahama Islands, collected by the late Dr. J. I. Northrop." Ann. N. Y. Acad. Sci., vol. ix.
1896. HADDON, A. C., AND DUERDEN, J. E. :  
 "On some Actiniaria from Australia and other Districts."—Trans. Roy. Dublin Soc., vol. vi. (ser. II.).
1896. KWIETNIEWSKI, C. R. :  
 "Revision der Actinien, welche von Herrn Prof. Studer auf der Reise der Korvette Gazelle um die Erde gesammelt wurden."—Jenaische Zeitschr., Bd. xxx.
1896. KWIETNIEWSKI, C. R. :  
 "Actiniaria von Ternate." Abhandl. d. Senckenb. Naturf. Ges., Bd. xxiii.
1897. DUERDEN, J. E. :  
 "The Actinarian Family Aliciidae." Ann. Mag. Nat. Hist., Ser. 6, vol. xx.
1898. DUERDEN, J. E. :  
 "Jamaican Actiniaria. Part I. : Zoanthæ. Trans. Roy. Dublin Soc., vol. vi. (ser. II.).
1898. DUERDEN, J. E. :  
 "The Actiniaria around Jamaica."—Journ. Instit. Jamaica, vol. II., No. 5.
1898. KWIETNIEWSKI, C. R. :  
 "Actiniaria von Ambon und Thursday Island."—Jenaische Denkschriften, viii.
1898. HADDON, A. C. :  
 "The Actiniaria of Torres Straits."—Trans. Roy. Dublin Soc., vol. vi. (ser. II.).
1898. DUERDEN, J. E. :  
 "On the Relations of certain Stichodactylinae to the Madreporaria."—Jour. Linn. Soc., vol. xxvi.

EXPLANATION OF PLATE X.

## PLATE X.

### Figure

1. *Phymanthus crucifer*. Plan of tentacular arrangement. Owing to the closeness of the mesenteries, only the pairs corresponding with the first five cycles of tentacles are represented. The two outermost cycles (vi., vii.,) of tentacles appear as if communicating with the same mesenterial chamber as some of the higher orders; this is, of course, not the case in the actual polyp.
2. *Phymanthus crucifer*. Single tentacle of the first cycle. Slightly enlarged.
3. *Actinotryx Sancti-Thomæ*. A small polyp with the smooth peripheral region of the disc reflected. Natural size.
4. *Actinotryx Sancti-Thomæ*. A portion of the peripheral tentaculiferous part of the disc.  $\times 3$ .
5. *Actinotryx Sancti-Thomæ*. Single discal or accessory tentacle.  $\times 3$ .
6. *Actinotryx Sancti-Thomæ*. Plan of tentacular arrangement. The peripheral series form only a single cycle, but are of three orders, not always regularly alternating. The inner series constitute a middle discal and a peristomial group.
7. *Ricordea florida*. Polyp with two oral apertures. The tentacles are often a little more knobbed than is here indicated. Natural size.
8. *Homostichanthus anemone*. Polyp, drawn from partly shrunk specimen preserved in formol.
9. *Actinoporus elegans*. Living polyp. Slightly reduced.
10. *Corynactis myrcia*. Retracted and extended polyps, still connected by a narrow cœnosarc. Slightly enlarged.
11. *Parazoanthus tunicans*. Portion of colony incrusting *Plumularia*. Natural size.
12. *Parazoanthus separatus*. Portion of a sponge with commensal polyps; retracted condition. Natural size.
13. *Parazoanthus separatus*. A single polyp.  $\times 3$ . The three last figures were drawn by Miss Verley.
14. *Parazoanthus monostichus*. Portion of sponge with numerous colonies. Natural size

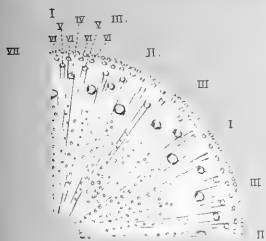

1.



2.



3.

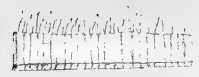

4.



5.



6.

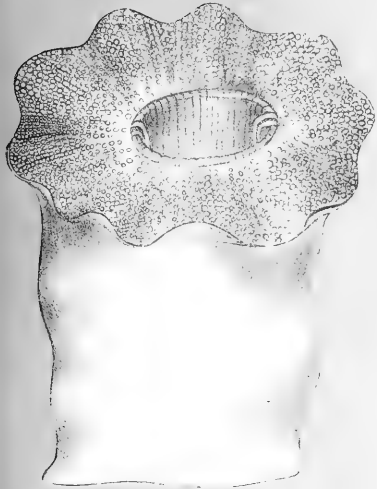

8.



7.



9.

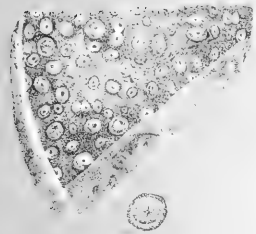

12.

13.



11.



10.

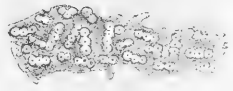

14.





EXPLANATION OF PLATE XI.

# PLATE XI.

## LETTERING ON THE FIGURES.

<p><i>col. w.</i>, . . . . . column wall.  <i>c. is.</i>, . . . . . cell-islet.  <i>c. s.</i>, . . . . . ciliated streak (Flimmerstreif).  <i>cu.</i>, . . . . . cuticle.  <i>d.</i>, . . . . . directives.  <i>disc.</i>, . . . . . disc.  <i>ect.</i>, . . . . . ectoderm.  <i>ect. can.</i>, . . . . . ectodermal canal.  <i>ect. m.</i>, . . . . . ectodermal muscle layer.  <i>enc. s.</i>, . . . . . encircling sinus.  <i>end.</i>, . . . . . endoderm.  <i>end. m.</i>, . . . . . endodermal muscle layer.  <i>fb. l.</i>, . . . . . fibrillar layer.  <i>fos.</i>, . . . . . fossa.  <i>gl. c.</i>, . . . . . gland cell.  <i>g. gr.</i>, . . . . . gonidial groove.  <i>g. s.</i>, . . . . . glandular streak.  <span style="padding-left: 40px;">(Drüsenstreif, Nesseldrüsenstreif).</span>  <i>inc.</i>, . . . . . incrustations.  <i>i. s.</i>, . . . . . intermediate streak.  <i>lac.</i>, . . . . . lacunæ.</p>	<p><i>m.</i>, . . . . . mesentery.  <i>m. fl.</i>, . . . . . mesenterial filament.  <i>mes.</i>, . . . . . mesoglea.  <i>mg. st.</i>, . . . . . marginal stoma.  <i>mr. m.</i>, . . . . . macronemic mesentery.  <i>nem.</i>, . . . . . nematocyst.  <i>nr. l.</i>, . . . . . nerve layer.  <i>ob. m.</i>, . . . . . oblique muscle.  <i>p. b. m.</i>, . . . . . parieto-basilar muscle.  <i>per. st.</i>, . . . . . perioral stoma.  <i>r. ect.</i>, . . . . . reflected ectoderm.  <i>r. m.</i>, . . . . . retractor muscle.  <i>r. s.</i>, . . . . . reticular streak.  <i>s. d.</i>, . . . . . sulcar directives.  <i>sl. d.</i>, . . . . . sulcular directives.  <i>s.p.</i>, . . . . . spermarium.  <i>sph. m.</i>, . . . . . sphincter muscle.  <i>st.</i>, . . . . . stomodæum.  <i>tent.</i>, . . . . . tentacle.  <i>zoox.</i>, . . . . . zooxanthella.  <i>I., II., III., &amp;c.</i>, . . . . . orders of mesenteries or tentacles.</p>
---	---

**Figure**

1. *Phymanthus crucifer*. Transverse section through a portion of the column-wall and a mesentery of the first order, and one of the mesenteries of the fourth order, taken a little below the stomodæal region. × 320.
2. *Phymanthus crucifer*. Transverse section through a trilobed mesenterial filament. × 320.
3. *Actinotryx Sancti-Thomæ*. Vertical section through the upper region of the column-wall, showing the mesogleal plaitings for the support of the sphincter muscle. × 250.
4. *Actinotryx Sancti-Thomæ*. Transverse section through a mesenterial filament, just below the stomodæal region. One of the large nematocysts is represented in longitudinal section and another in transverse section. × 250.
5. *Ricordea florida*. Plan of tentacular arrangement. The members of the outermost cycle are in the same radial areas as the inner tentacles, and alternate with those of the next cycle within. The arrangement in orders is not very regular in larger polyps.
6. *Ricordea florida*. Transverse section through the stomodæal region to show the irregular arrangement of the mesenteries, and the columnar and stomodæal mesogleal processes. Only a few of the columnar processes are represented. × 12.
7. *Stoichactis helianthus*. Plan of tentacular arrangement in a young specimen. The members of the outermost cycle communicate with the exocœles and alternate with all the radial rows, which are endocœlic.
8. *Actinoporus elegans*. Plan of tentacular arrangement.

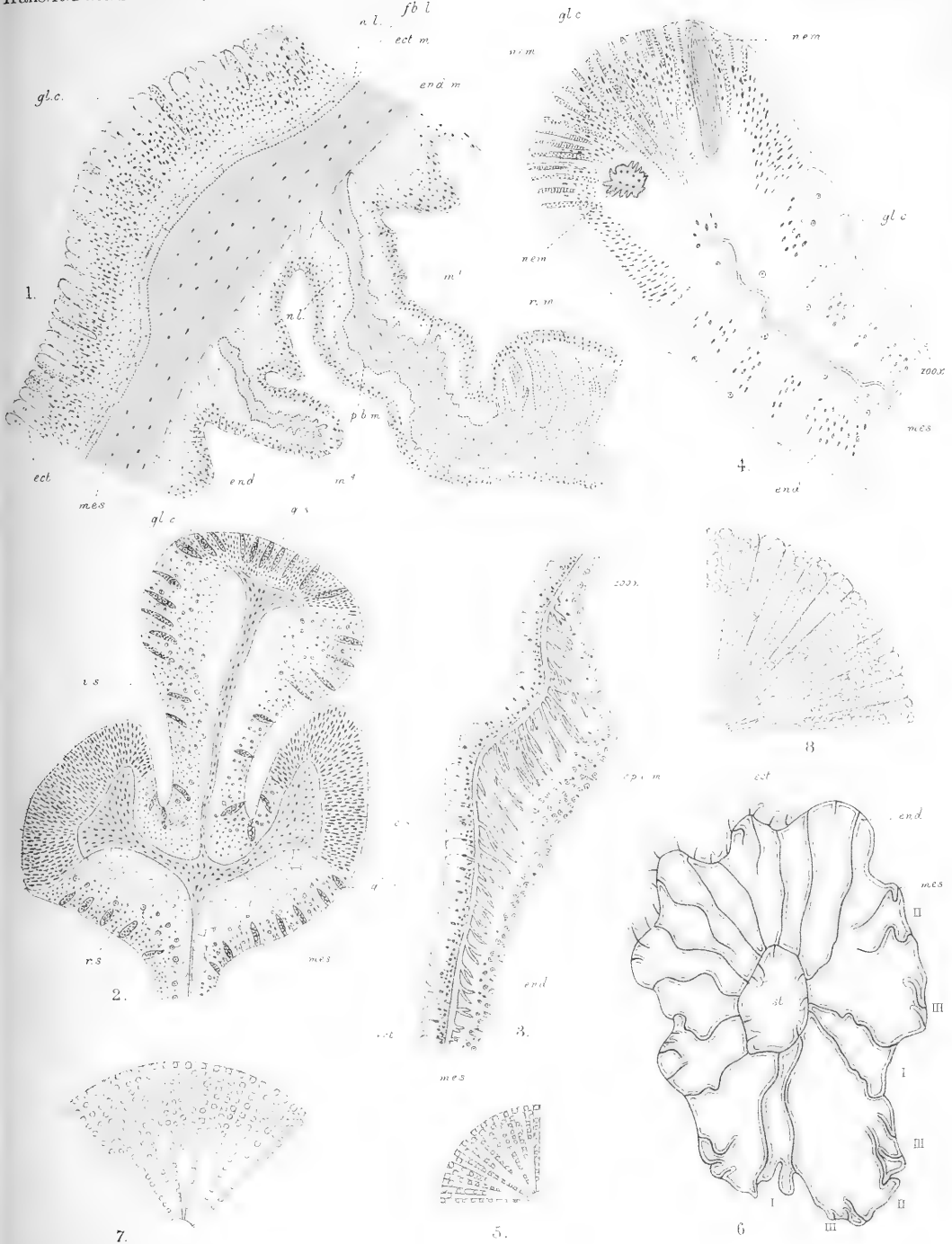



EXPLANATION OF PLATE XII.

## PLATE XII.

### LETTERING ON THE FIGURES.

<p><i>col. to.</i>, . . . . . column wall.  <i>c. is.</i>, . . . . . cell-islet.  <i>c. s.</i>, . . . . . ciliated streak (Fimmerstreif).  <i>cu.</i>, . . . . . cuticle.  <i>d.</i>, . . . . . directives.  <i>disc.</i>, . . . . . disc.  <i>ect.</i>, . . . . . ectoderm.  <i>ect. can.</i>, . . . . . ectodermal canal.  <i>ect. m.</i>, . . . . . ectodermal muscle layer.  <i>enc. s.</i>, . . . . . encircling sinus.  <i>end.</i>, . . . . . endoderm.  <i>end. m.</i>, . . . . . endodermal muscle layer.  <i>fb. l.</i>, . . . . . fibrillar layer.  <i>fos.</i>, . . . . . fossa.  <i>gl. c.</i>, . . . . . gland cell.  <i>g. gr.</i>, . . . . . gonidial groove.  <i>g. s.</i>, . . . . . glandular streak.  <span style="padding-left: 40px;">(Drüsenstreif, Nesselrüsenstreif).</span>  <i>inc.</i>, . . . . . incrustations.  <i>i. s.</i>, . . . . . intermediate streak.  <i>lac.</i>, . . . . . lacunæ.</p>	<p><i>m.</i>, . . . . . mesentery.  <i>m. fil.</i>, . . . . . mesenterial filament.  <i>mes.</i>, . . . . . mesogloea.  <i>mg. st.</i>, . . . . . marginal stoma.  <i>mr. m.</i>, . . . . . macrocnemic mesentery.  <i>nem.</i>, . . . . . nematocyst.  <i>nr. l.</i>, . . . . . nerve layer.  <i>ob. m.</i>, . . . . . oblique muscle.  <i>p. b. m.</i>, . . . . . parieto-basilar muscle.  <i>per. st.</i>, . . . . . perioral stoma.  <i>r. ect.</i>, . . . . . reflected ectoderm.  <i>r. m.</i>, . . . . . retractor muscle.  <i>r. s.</i>, . . . . . reticular streak.  <i>s. d.</i>, . . . . . sulcar directives.  <i>sl. d.</i>, . . . . . sulcular directives.  <i>sp.</i>, . . . . . spermarium.  <i>sph. m.</i>, . . . . . sphincter muscle.  <i>st.</i>, . . . . . stomodæum.  <i>tent.</i>, . . . . . tentacle.  <i>zoox.</i>, . . . . . zooxanthellæ.  <i>I., II., III., &amp;c.</i>, . . . . . orders of mesenteries or tentacles.</p>
--	---

#### Figure

1. *Ricordea florida*. Transverse section through the stomodæal region of a polyp in which the mesogloæal plaitings for the support of the retractor muscle are displayed, as also the irregular development of the pairs of mesenteries of the third order. Three pairs of perfect mesenteries occur on the one side of the directives and four pairs on the other. × 12.
2. *Ricordea florida*. Transverse section through a portion of the column-wall and a mesentery of the first order. × 320.
3. *Actinotryx Sancti-Thomæ*. Transverse section through a fertile mesentery with ripe spermata in act of dehiscing. × 75.
4. *Homostichanthus anemone*. Plan of tentacular arrangement. An outer series of cycles in which the same number of tentacles occurs in each endocœle and exocœle can be distinguished from an inner series in which the cycles are imperfect, and more separated one from the other.
5. *Homostichanthus anemone*. Radial section of portion of column-wall. × 320.
6. *Homostichanthus anemone*. Tangential section through the periphery of the disc and uppermost region of the column-wall. The portion represented is but slightly tangential, so that only two mesenteries are cut through, and two tentacles are in communication with an exocœle and two with an endocœle. The mesogloæal plaitings supporting the restricted sphincter muscle are a little longer in a truly radial section than are here represented. × 25.
7. *Corynactis myrcia*. Plan of tentacular arrangement.

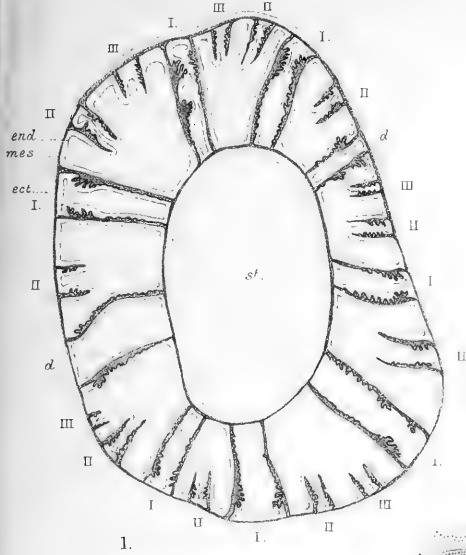

1.



2.

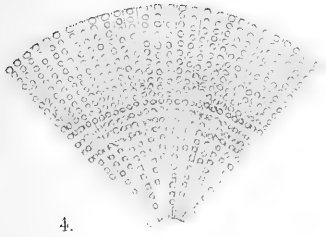

3.



4.



5.

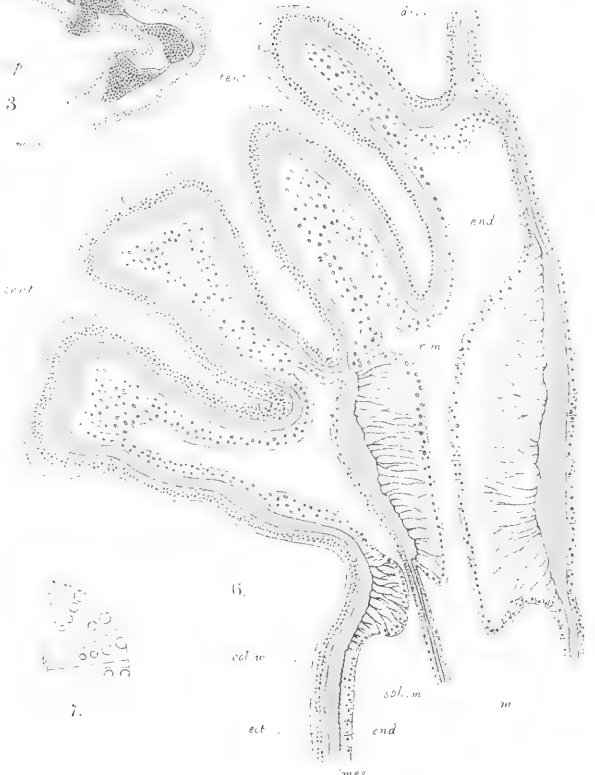

6.



7.





EXPLANATION OF PLATE XIII.

# PLATE XIII.

## LETTERING ON THE FIGURES.

<p><i>col. w.</i>, . . . . . column wall.  <i>c. is.</i>, . . . . . cell-islet.  <i>c. s.</i>, . . . . . ciliated streak (Flimmerstreif).  <i>cu.</i>, . . . . . cuticle.  <i>d.</i>, . . . . . directives.  <i>disc.</i>, . . . . . disc.  <i>ect.</i>, . . . . . ectoderm.  <i>ect. can.</i>, . . . . . ectodermal canal.  <i>ect. m.</i>, . . . . . ectodermal muscle layer.  <i>enc. s.</i>, . . . . . encircling sinus.  <i>end.</i>, . . . . . endoderm.  <i>end. m.</i>, . . . . . endodermal muscle layer.  <i>fb. l.</i>, . . . . . fibrillar layer.  <i>foss.</i>, . . . . . fossa.  <i>gl. c.</i>, . . . . . gland cell.  <i>g-gr.</i>, . . . . . gonidial groove.  <i>g. s.</i>, . . . . . glandular streak            (Drüsenstreif, Nesseldrüsenstreif).  <i>inc.</i>, . . . . . incrustations.  <i>i. s.</i>, . . . . . intermediate streak.  <i>lac.</i>, . . . . . lacunæ.</p>	<p><i>m.</i>, . . . . . mesentery.  <i>m. fil.</i>, . . . . . mesenterial filament.  <i>mes.</i>, . . . . . mesoglea.  <i>mg. st.</i>, . . . . . marginal stoma.  <i>mr. m.</i>, . . . . . macrocnemic mesentery.  <i>nem.</i>, . . . . . nematocyst.  <i>nr. l.</i>, . . . . . nerve layer.  <i>ob. m.</i>, . . . . . oblique muscle.  <i>p. b. m.</i>, . . . . . parieto-basilar muscle.  <i>per. st.</i>, . . . . . perioral stoma.  <i>r. ect.</i>, . . . . . reflected ectoderm.  <i>r. m.</i>, . . . . . retractor muscle.  <i>r. s.</i>, . . . . . reticular streak.  <i>s. d.</i>, . . . . . sulcar directives.  <i>sl. d.</i>, . . . . . sulcular directives.  <i>sp.</i>, . . . . . spermarium.  <i>sph. m.</i>, . . . . . sphincter muscle.  <i>st.</i>, . . . . . stomodæum.  <i>tent.</i>, . . . . . tentacle.  <i>zoox.</i>, . . . . . zooxanthellæ.            I., II., III., &amp;c., . . . . . orders of mesenteries or tentacles.</p>
---	---

Figure

1. *Ricordea florida*. Transverse section towards the free edge of a mesentery a little below the stomodæal region, showing the imperfect mesenterial filament. × 250.
2. *Actinoporus elegans*. Transverse section through a portion of the column-wall and of a mesentery, in the upper region of the polyp. × 320.
3. *Corynactis myrcia*. Radial section through the infolded region of the column-wall. × 250.
4. *Corynactis myrcia*. Transverse section through a portion of a polyp near the aboral termination of the stomodæum. The stomodæal wall is folded backwardly and outwardly upon itself, so that it is here cut through twice, and the enclosed endoderm is shown on the left side. The stomodæum first terminates opposite the pair of directives. As the mesenteries cease their connexion they retain around their free edge a tissue like that of the stomodæal ectoderm which passes insensibly into the mesenterial filaments. × 50.
5. *Corynactis myrcia*. Transverse section through the stem of a tentacle showing the brush-like character of the fibrillæ radiating from the mesogleal folds. × 320.
6. *Actinoporus elegans*. Radial section through the upper part of the polyp. Slightly reduced.
7. *Parazoanthus tunicans*. Radial section through the distal region of the column-wall. × 75.
8. *Parazoanthus separatus*. Vertical section through the base. × 250.
9. *Parazoanthus monostichus*. Transverse section of a polyp through the elevated peristome and capitular region. The peripheral tissues are disorganized as a result of the presence of the numerous circularly-arranged sponge spicules. × 75.

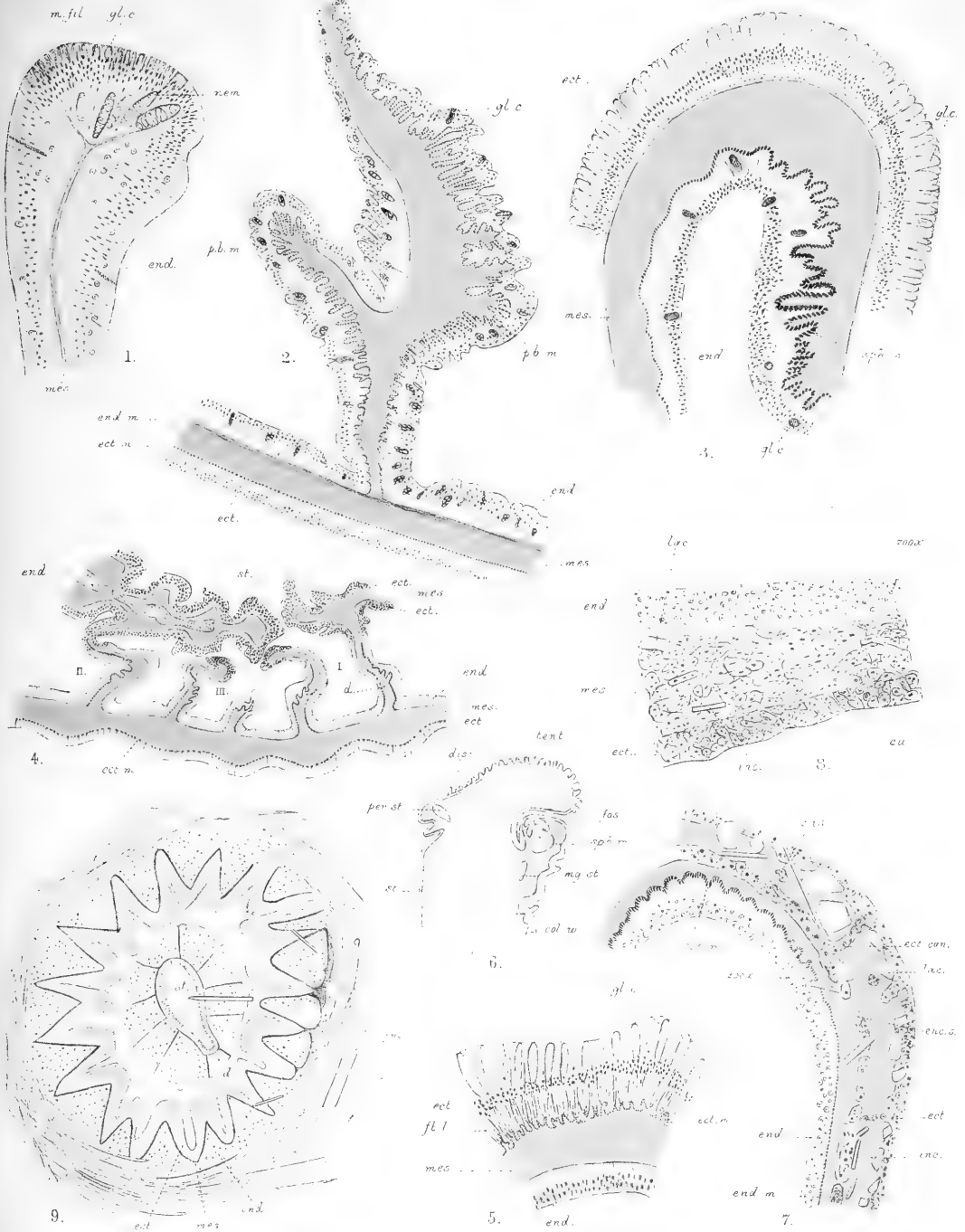



EXPLANATION OF PLATE XIV.

## PLATE XIV.

### LETTERING ON THE FIGURES.

<p><i>col. w.</i>, . . . . . column wall.</p> <p><i>c. is.</i>, . . . . . cell-islet.</p> <p><i>c. s.</i>, . . . . . ciliated streak (Flimmerstreif).</p> <p><i>cu.</i>, . . . . . cuticle.</p> <p><i>d.</i>, . . . . . directives.</p> <p><i>disc.</i>, . . . . . disc.</p> <p><i>ect.</i>, . . . . . ectoderm.</p> <p><i>ect. can.</i>, . . . . . ectodermal canal.</p> <p><i>ect. m.</i>, . . . . . ectodermal muscle layer.</p> <p><i>enc. s.</i>, . . . . . encircling sinus.</p> <p><i>end.</i>, . . . . . endoderm.</p> <p><i>end. m.</i>, . . . . . endodermal muscle layer.</p> <p><i>fb. l.</i>, . . . . . fibrillar layer.</p> <p><i>fos.</i>, . . . . . fossa.</p> <p><i>gl. c.</i>, . . . . . gland cell.</p> <p><i>g. gr.</i>, . . . . . gonidial groove.</p> <p><i>g. s.</i>, . . . . . glandular streak. (Drüsenstreif, Nesselrüsenstreif).</p> <p><i>inc.</i>, . . . . . incrustations.</p> <p><i>i. s.</i>, . . . . . intermediate streak.</p> <p><i>lac.</i>, . . . . . lacunæ.</p>	<p><i>m.</i>, . . . . . mesentery.</p> <p><i>m. fil.</i>, . . . . . mesenterial filament.</p> <p><i>mes.</i>, . . . . . mesogloea.</p> <p><i>mg. st.</i>, . . . . . marginal stoma.</p> <p><i>mr. m.</i>, . . . . . macrocnemic mesentery.</p> <p><i>nem.</i>, . . . . . nematocyst.</p> <p><i>nr. l.</i>, . . . . . nerve layer.</p> <p><i>ob. m.</i>, . . . . . oblique muscle.</p> <p><i>p. b. m.</i>, . . . . . parieto-basilar muscle.</p> <p><i>per. st.</i>, . . . . . perioral stoma.</p> <p><i>r. ect.</i>, . . . . . reflected ectoderm.</p> <p><i>r. m.</i>, . . . . . retractor muscle.</p> <p><i>r. s.</i>, . . . . . reticular streak.</p> <p><i>s. d.</i>, . . . . . sulcar directives.</p> <p><i>sl. d.</i>, . . . . . sulcular directives.</p> <p><i>sp.</i>, . . . . . spermarium.</p> <p><i>sph. m.</i>, . . . . . sphincter muscle.</p> <p><i>st.</i>, . . . . . stomodæum.</p> <p><i>tent.</i>, . . . . . tentacle.</p> <p><i>zooz.</i>, . . . . . zooxanthellæ.</p> <p>I., II., III., &amp;c., . . . . . orders of mesenteries or tentacles.</p>
--	--

**Figure**

1. *Stoichactis helianthus*. Radial section through the fossa and across the sphincter muscle. × 50.
2. *Homonstichanthus anemone*. Transverse section through the stomodæal wall enclosing a gonidial groove. × 50.
3. *Actinoporus elegans*. Vertical section through the apex of the column and the periphery of the disc. × 50.
4. *Parazoanthus separatus*. Radial section through one-half of a retracted polyp. The section passes through a mesenteric chamber. × 75.

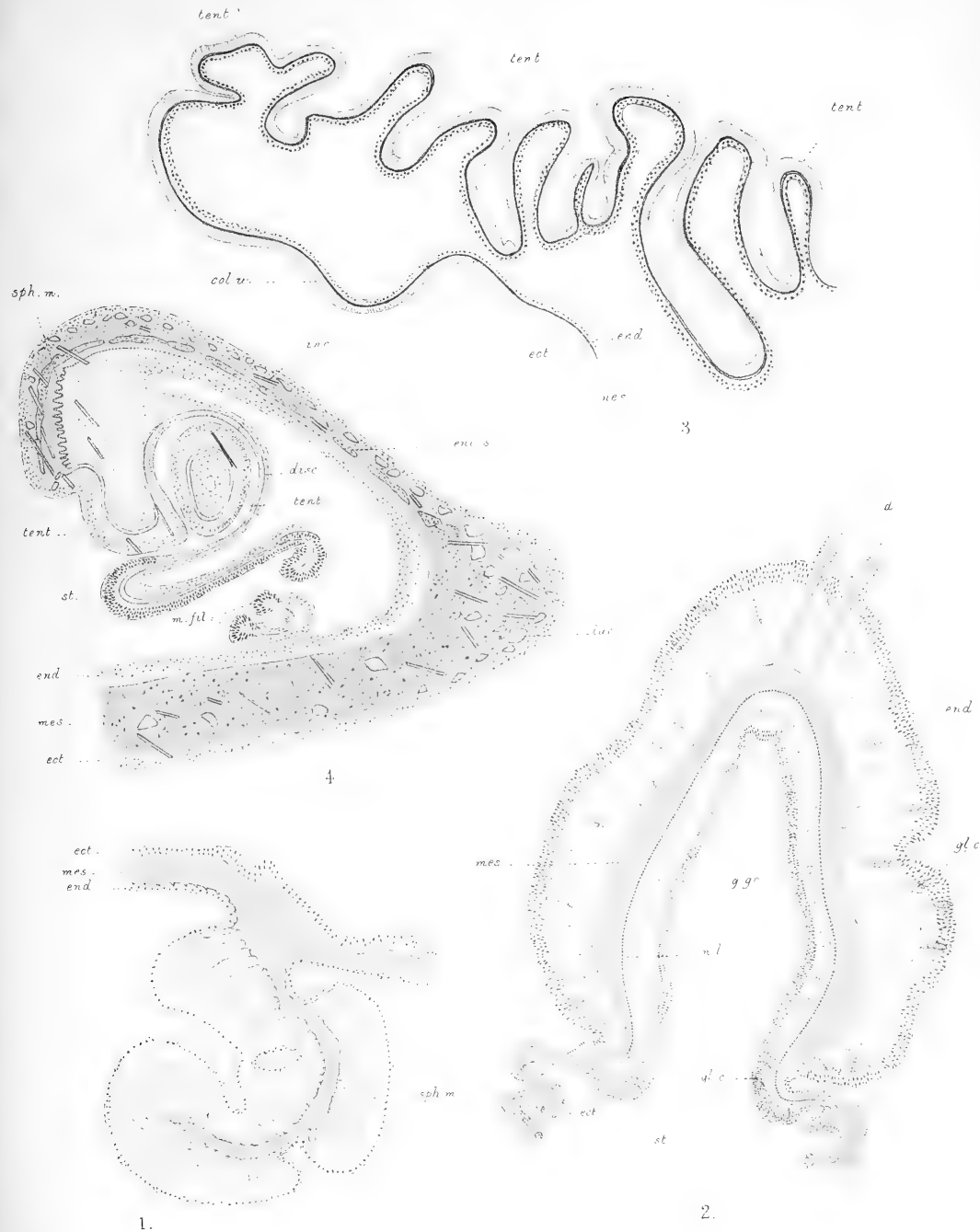

1.

2.





EXPLANATION OF PLATE XV.

# PLATE XV.

## LETTERING ON THE FIGURES.

<p><i>col. w.</i>, . . . . . column wall.  <i>c. is.</i>, . . . . . cell-islet.  <i>c. s.</i>, . . . . . ciliated streak (Flimmerstreif).  <i>cu.</i>, . . . . . cuticle.  <i>d.</i>, . . . . . directives.  <i>disc.</i>, . . . . . disc.  <i>ect.</i>, . . . . . ectoderm.  <i>ect. can.</i>, . . . . . ectodermal canal.  <i>ect. m.</i>, . . . . . ectodermal muscle layer.  <i>enc. s.</i>, . . . . . encircling sinus.  <i>end.</i>, . . . . . endoderm.  <i>end. m.</i>, . . . . . endodermal muscle layer.  <i>fb. l.</i>, . . . . . fibrillar layer.  <i>fos.</i>, . . . . . fossa.  <i>gl. c.</i>, . . . . . gland cell.  <i>g. gr.</i>, . . . . . gonidial groove.  <i>g. s.</i>, . . . . . glandular streak.  <span style="padding-left: 2em;">(Drüsenstreif, Nesselldrüsenstreif).</span>  <i>inc.</i>, . . . . . incrustations.  <i>i. s.</i>, . . . . . intermediate streak.  <i>lac.</i>, . . . . . lacunæ.</p>	<p><i>m.</i>, . . . . . mesentery.  <i>m. fil.</i>, . . . . . mesenterial filament.  <i>mes.</i>, . . . . . mesogloea.  <i>mg. st.</i>, . . . . . marginal stoma.  <i>mr. m.</i>, . . . . . macrocnemic mesentery.  <i>nem.</i>, . . . . . nematocyst.  <i>nr. l.</i>, . . . . . nerve layer.  <i>ob. m.</i>, . . . . . oblique muscle.  <i>p. b. m.</i>, . . . . . parieto-basilar muscle.  <i>per. st.</i>, . . . . . perioral stoma.  <i>r. ect.</i>, . . . . . reflected ectoderm.  <i>r. m.</i>, . . . . . retractor muscle.  <i>r. s.</i>, . . . . . reticular streak.  <i>s. d.</i>, . . . . . sulcar directives.  <i>st. d.</i>, . . . . . sulcular directives.  <i>sp.</i>, . . . . . spermarium.  <i>sph. m.</i>, . . . . . sphincter muscle.  <i>st.</i>, . . . . . stomodæum.  <i>tent.</i>, . . . . . tentacle.  <i>zoox.</i>, . . . . . zooxanthellæ.            I, II, III, &amp;c., . . . . . orders of mesenteries or tentacles.</p>
---	---

**Figure**

1. *Homostichanthus anemone*. Transverse section through the knob of a tentacle. × 320.
2. *Actinoporus elegans*. Radial section through the wall of the fossa and across the sphincter muscle. × 25.
3. *Corynactis myrcia*. Transverse section through a mesentery a little below the stomodæal region. The mesenterial filament at the free end is simple, while the endoderm behind is swollen, giving somewhat the appearance of a trilobed filament. × 320.
4. *Parazoanthus tunicans*. Transverse section of a polyp through the lower part of the stomodæum. The lacunæ represent the spaces from which the calcareous incrustations have been dissolved; the sponge spicules remain. × 50.
5. *Parazoanthus tunicans*. Section through a fold of a mesentery containing three spermaria. × 320.

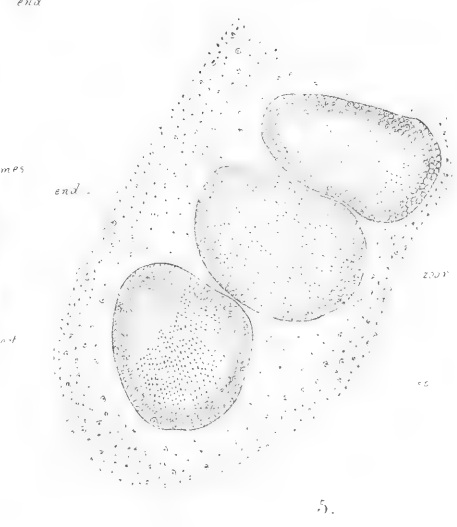
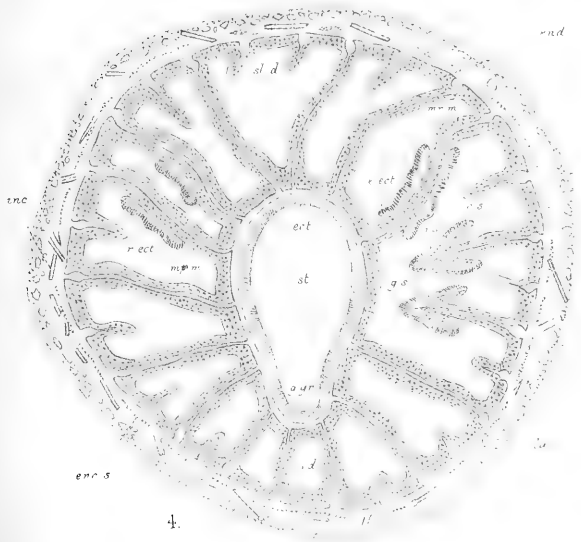
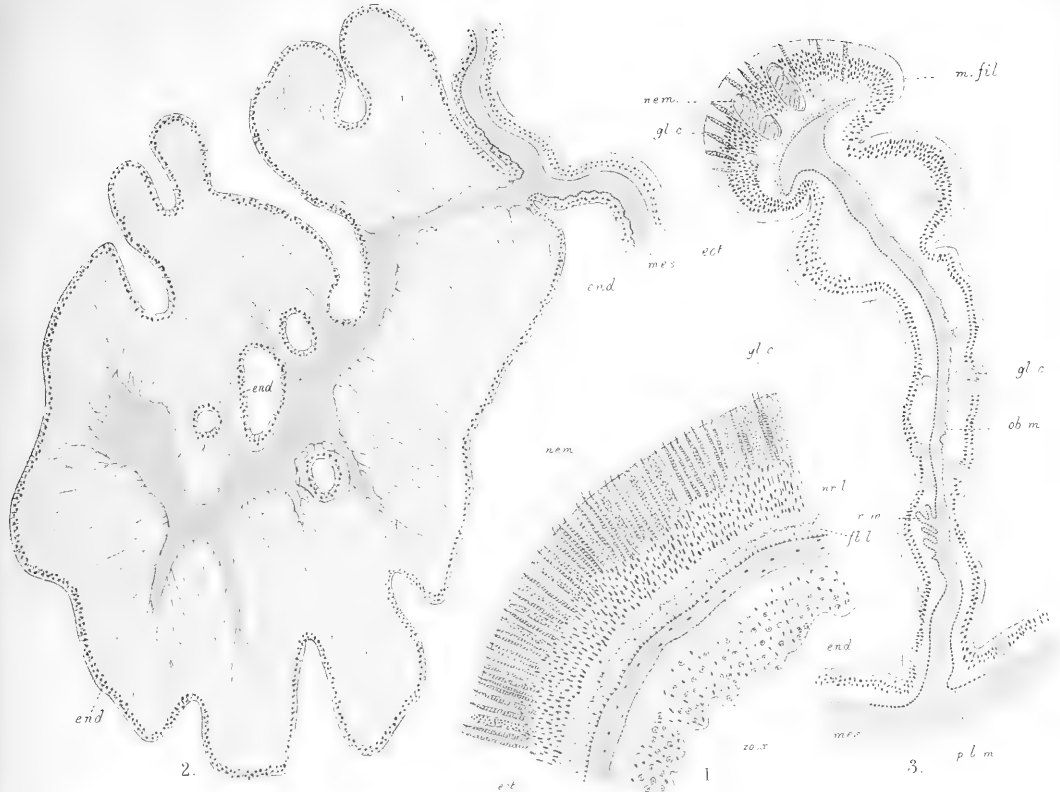





## TRANSACTIONS (SERIES II.).

---

VOL. I.—Parts 1-25.—November, 1877, to September, 1883.

VOL. II.—Parts 1-2.—August, 1879, to April, 1882.

VOL. III.—Parts 1-14.—September, 1883, to November, 1887.

VOL. IV.—Parts 1-14.—April, 1888, to November, 1892.

VOL. V.—Parts 1-13.—May, 1893, to July, 1896.

VOL. VI.—Parts 1-16.—February, 1896, to August, 1898.

---

### VOLUME VII.

#### PART

1. A Determination of the Wave-lengths of the Principal Lines in the Spectrum of Gallium, showing their Identity with Two Lines in the Solar Spectrum. By W. N. HARTLEY, F.R.S., and HUGH RAMAGE, A.R.C.S.C.I. Plate I. (August, 1898.) 1s.
2. Radiating Phenomena in a Strong Magnetic Field. Part II.—Magnetic Perturbations of the Spectral Lines. By THOMAS PRESTON, M.A., D.SC., F.R.S. (June, 1899.) 1s.
3. An Estimate of the Geological Age of the Earth. By J. JOLY, M.A., B.A.I., D.SC., F.R.S., F.G.S., M.R.I.A., Honorary Secretary of the Royal Dublin Society; Professor of Geology and Mineralogy in the University of Dublin. (November, 1899.) 1s. 6d.
4. On the Electrical Conductivity and Magnetic Permeability of various Alloys of Iron. By W. F. BARRETT, F.R.S.; W. BROWN, B.Sc.; R. A. HADFIELD, M. Inst. C.E. Plates II. to IX. (January, 1900.) 4s.
5. On some Novel Thermo-Electric Phenomena. By W. F. BARRETT, F.R.S., Professor of Experimental Physics in the Royal College of Science for Ireland. Plate IXA. (January, 1900.) 1s.
6. Jamaican Actiniaria. Part II.—Stichodactylinæ and Zoanthææ. By J. E. DUERDEN, Assoc. R. C. Sc. (Lond.), Curator of the Museum of the Institute of Jamaica. Plates X. to XV. (January, 1900.) 3s.

[APRIL, 1900.]

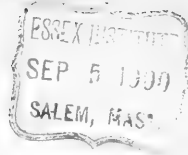

THE

SCIENTIFIC TRANSACTIONS

OF THE

ROYAL DUBLIN SOCIETY.

VOLUME VII.—(SERIES II.)

---

VII.

SURVEY OF FISHING GROUNDS, WEST COAST OF IRELAND, 1890-1891.

X.—REPORT ON THE CRUSTACEA SCHIZOPODA OF IRELAND.

By ERNEST W. L. HOLT, AND W. I. BEAUMONT, B.A., CANTAB.

(PLATES XVI.)

---

DUBLIN:

PUBLISHED BY THE ROYAL DUBLIN SOCIETY.

WILLIAMS AND NORGATE,

14, HENRIETTA STREET, COVENT GARDEN, LONDON;

20, SOUTH FREDERICK STREET, EDINBURGH; AND 7, BROAD STREET, OXFORD.

PRINTED AT THE UNIVERSITY PRESS, BY PONSONBY AND WELDRICK.

1900.

---

*Price One Shilling and Sixpence.*





## INDEX SLIP.

HOLT, Ernest W. L. and Beaumont, W. L.—Survey of Fishing Grounds, West Coast of Ireland, 1890-1891. X. —Report on the Crustacea Schizopoda of Ireland. Roy. Dublin Soc. Trans., s. 2, vol. 7, 1900, pp. 221-252.

Crustacea Schizopoda of Ireland, Report on the.

Holt, Ernest W. L.

Roy. Dublin Soc. Trans., s. 2, vol. 7, 1900, pp. 221-252.



[APRIL, 1900.]

THE  
SCIENTIFIC TRANSACTIONS  
OF THE  
ROYAL DUBLIN SOCIETY.

VOLUME VII.—(SERIES II.)

---

VII.

SURVEY OF FISHING GROUNDS, WEST COAST OF IRELAND, 1890-1891.

X.—REPORT ON THE CRUSTACEA SCHIZOPODA OF IRELAND.

By ERNEST W. L. HOLT, AND W. I. BEAUMONT, B.A., CANTAB.

(PLATES XVI.)

---

DUBLIN:  
PUBLISHED BY THE ROYAL DUBLIN SOCIETY.  
WILLIAMS AND NORGATE,  
14, HENRIETTA STREET, COVENT GARDEN, LONDON;  
20, SOUTH FREDERICK STREET, EDINBURGH; AND 7, BROAD STREET, OXFORD.  
PRINTED AT THE UNIVERSITY PRESS, BY PONSONBY AND WELDRICK.

1900.



## VII.

SURVEY OF FISHING-GROUNDS, WEST COAST OF IRELAND, 1890-1891.  
X.—REPORT ON THE CRUSTACEA SCHIZOPODA OF IRELAND. BY  
ERNEST W. L. HOLT, AND W. I. BEAUMONT, B.A., CANTAB.

(PLATE XVI.)

COMMUNICATED BY DR. R. F. SCHARFF.

[Read APRIL 19, Received for Publication MAY 30, 1899. Published APRIL 30, 1900.]

WHEN the Survey terminated in 1891 all the collections, with the exception of certain duplicates otherwise disposed of by the Society, were handed over to the National Museum. A great deal of the material remained still unexamined, or had only been roughly sorted by one of us during the survey. This was especially the case with the smaller Crustacea and other minute forms taken in fine-meshed nets of various descriptions. We have recently been able, by the permission of Dr. R. F. Scharff, to examine a number of bottles containing such gatherings, and now present the results of our observations in so far as concerns the Schizopoda.

At the same time, since the energies of the Society are once more directed to the marine zoology of the country, we have endeavoured to compile as complete a list of Irish members of the group as can be obtained from all the material in the national collection, and from the meagre literature of the subject. Such a list, imperfect as it certainly is, cannot fail to be useful as a basis for future observations. It has been brought as far as possible up to date, while in press, by observations made at the Society's Marine Laboratory during the present year, and by the examination of the "Oceana" Collection.

Though in themselves of no commercial value, the Schizopoda form a most important item in the food of fishes, while the observed conditions of their distribution, and the pelagic or partially pelagic habit of at least some of the species appear likely to yield results of interest, were the subject adequately studied.

Norman's admirably useful synopsis of the British members† is sufficiently recent to enable us to confine our introductory remarks to a brief comparison of

† "British Schizopoda of the families Lophogastridæ and Euphausidæ." *Ann. Mag. Nat. Hist.*, S. 6, ix., 1892, p. 454, and "British Mysidæ," *ibid.*, x., 1892, p. 143.

the Irish fauna, as we at present know it, with that of the British Isles generally. Norman's list contains one species of Lophogastridæ, seven of Euphausidæ, and thirty-three of Mysidæ. Of the Euphausidæ, *Boreophausia inermis* (Krøyer), *B. Ruschii* (M. Sars), *Thysanoessa longicaudata* (Krøyer), and *Nematoscelis megalops*, G. O. Sars, have not yet been taken in Irish waters. *Nematodactylus bööpis*, Calman, a recent addition to the family from deep water off the S.W. of Ireland, cannot yet be included in the British fauna, since it has only been taken at 1020 fathoms, or 20 fathoms below the line of soundings which constitutes Norman's western boundary of our zoological dominions. The same remark applies to *Eucopia australis*; and these species will probably be met, as predicted by Norman in the case of *Euphausia pellucida*, Dana, within the British area.

Recent observations have altered Norman's list of British species of Mysidæ in personnel, but not in number, *Siriella frontalis*, M.-Edw., having been expunged from the list, while *Dasymysis (Acanthomysis) longicornis*, M.-Edw., has been added thereto.

We can find no record of the following species from Irish waters, nor are they represented in our material:—

*Siriella norvegica*, G. O. Sars.

*S. jaltensis*, Czern.

*S. Brooki*, Norman.

*Erythropus Goëssi*, G. O. Sars.

*E. elegans*, G. O. Sars.

*Schistomysis Helleri* (G. O. Sars).

*S. Parkeri*, Norman.

As some set-off to these deficiencies, we are able to add two species to the British list, viz. *Parerythropus obesa*, G. O. Sars, and *Mysidella typica*, G. O. Sars.

Two\* species, *S. norvegica* and *E. elegans*, have been recorded by Walker from the Irish Sea.† It seems improbable that they are absent from the coast of county Down, and, in fact, the observed differences in the British and Irish lists are unlikely to survive a proper investigation of the Irish area. The Society's surveying expeditions were concerned with the fishing-grounds, at that time in many cases unexplored. These grounds are mostly at considerable depths, and comparatively little time was available for inshore operations with nets suitable for the capture of Mysidæ and the like. Hence it is by no means remarkable that the littoral forms, which are a large proportion of the above list, do not

† Though the localities of some of Walker's records from the Irish Sea are actually nearer to the Irish than to the English coast, the deep channel to the westward of the Isle of Man appears to be the natural line of demarcation between Great Britain and Ireland.

appear in the collection. The bulk of the survey material was taken in bags of mosquito-netting suspended inside the large beam trawl. This is, apparently, a most efficacious method of collecting Schizopods, but has the disadvantage of injuring the specimens on account of the strain against the meshes resulting from the comparatively high speed at which the trawl is hauled, and the frequent irruption of large fish, crabs, sand, and other injurious matters. Mosquito-netting is, moreover, rather coarse for such small creatures as *Erythrops elegans*, &c., and this must be borne in mind in considering the evidence afforded by our record of the numbers of different species taken in the several hauls.

In the systematic list it will be understood that we adopt Norman's classification and synonymy, unless the contrary is expressly stated. Further, in the brief account which we have given of the distribution, it has seemed to us desirable to condense the references by ascribing to Norman (A. M. N.\*) those records, whether original or compiled, which appear in his paper. In some cases we have condensed the record still further, as by substituting "E. and W. Scotland" for various localities on both coasts. Professor Sars' work is too well known to need mention here; while Norman has himself acknowledged the assistance of Mr. Thomas Scott† and others in the communication of British forms. The most important paper, after Norman's, dealing with Irish Schizopoda, is that of Mr. A. O. Walker.‡ Records other than Irish, which have appeared subsequent to Canon Norman's, are indicated by the author's name or initials. Mr. Walker's records from the Irish Sea, which are of importance on account of the propinquity of the localities to the Irish area and of the absence of any records from the adjacent parts of the Irish coast, are to be found in the Transactions of the Liverpool Biological Society. Where a locality is followed by a colon or full stop without the citation of an authority, it must be taken that we are ourselves responsible, while a note of exclamation indicates the confirmation by ourselves of the record of a previous observer.

Sub-order.—SCHIZOPODA.

Family.—LOPHOGASTRIDÆ.

Genus *Lophogaster*, M. Sars.

*Lophogaster typicus*, M. Sars.

*Not in the Survey Collection.*

*Museum, Dublin.*—50 miles W.  $\frac{1}{2}$  S. of Dursey head, 214 fathoms. July 15th, 1886.

† Mr. Scott's recent records are indicated below by the initials T. S.

‡ Trans. Liverpool Biol. Soc., xii., 1893, p. 164 (A. O. W.\*).

*Previous Irish Records.*—Off S. W. of Ireland, 90 (and 1630) fathoms (A. M. N.\*); off Co. Kerry, 40 fathoms (A. O. W.\*).

*Distribution.*—East of Shetland (A.M.N.\*).

Norway; Bay of Biscay; south of Cape of Good Hope (A. M. N.\*): Mediterranean (Caullery, Pruvot).

Family.—**EUPHAUSIDÆ**.†

Genus **Nyctiphanes**, G. O. Sars.

**Nyctiphanes norvegica** (M. Sars).

*Survey.*—Station 115, off the Skelligs, 62 to 52 fathoms, mud and sand. August 20th, 1890.

Station 165, 28 miles N.W. of Achill Head, 154 fathoms, sand, April 20th, 1891 (a number of specimens in the stomach of a black-mouthed dog-fish, *Pristiurus melanostoma*: they were bright blue before preservation).

*Marine Laboratory.*—8 miles off Achill Head, 13th April, 1899 (many specimens in stomach of mackerel from surface drift-net).

*Museum, Dublin.*—No. 114, 1896. Whitepool Bay, Co. Antrim, per Mr. R. Welch. A number of specimens cast up on the beach.

*Previous Irish Records.*—Off Valentia (A. M. N.\*): Valentia Harbour (A. O. W.\*): off N. of Ireland (Herdman).

*Distribution.*—East and west coasts of Scotland (A. M. N.\*): Irish Sea and North Channel (Herdman).

Norway, Faroë Channel, &c.; N.E. America (A. M. N.\*): Bay of Biscay (Caullery): N.E. America (Herdman).

The presence of these Schizopods in the stomach of a ground-fish like *Pristiurus* affords fairly conclusive proof that they are not at all times pelagic in habit. The specimens from off the Skelligs may have been taken either at the bottom or during the ascent of the net, and the same remark would seem to apply to creatures taken in any ordinary net which cannot be opened and closed at given depths. Professor Herdman obtained his material entirely at the surface by means of the pumps of an Atlantic liner (Trans. Liverpool Biol. Soc., xii., 1898, p. 33); and it is noteworthy that the species was only met with off the coasts of the European and American continents, and not in the central part of the Atlantic.

† *Euphausia pellucida*, Dana; *Stylocheiron* sp. See Note added in Press, p. 250.



**Nyctiphanes Couchii** (Bell).

Plate XVI., fig. 1; and fig. I., p. 226.

*Thysanopoda Couchii*, Bell, "British Stalk-eyed Crustacea," 1853, p. 346.

Bell's figure, the only drawing of the species with which we are acquainted, is on a very small scale, and not wholly satisfactory. By the kindness of Mr. C. Green, B.A. (T.C.D.), we are able to give a more detailed illustration of the whole animal, the subject in this case being a male from Valentia Harbour. We are indebted to Mr. M. F. Woodward for a dissection and drawing of the branchial apparatus of the same specimen, and of the copulatory processes of the first pleopods of this and the preceding species. We take the subjoined diagnosis, with slight verbal alteration, from Norman.

*Carapace* without lateral spines, its lobes not produced over the eyes. *Rostrum* broadly and bluntly triangular, concealing the base of the eye-stalks. A spine over the base of the *telson* and a small simple ventral preanal spine. In the male the *antennules*, in addition to the usual reflexed membranous leaflet at the end of the first joint, have another reflexed membranous leaflet at the end of the second joint of the peduncle, the distal portion of the leaflet being cut into digitated processes.

The copulatory apparatus of the inner plate of the first pleopod (fig. I., p. 226, 8) in a specimen of 12 mm. is not unlike that of *N. australis*, G. O. Sars (*cf.* Sars, Challenger Report, XIII., Pl. xxi., fig. 6). It is much less complicated than in full-grown *N. norvegica* (*cf.* fig. I., 9). We have had no opportunity of examining males of the last-named species at sizes corresponding to what appears to be the fully-developed condition of *N. Couchii*. (See Note added in Press, p. 250.)

*Not in the Survey Collection.*

Valentia Harbour, surface, September 30th, 1898, per Miss C. Delap.

*Previous Irish Record.*—Off Valentia (A. M. N.\*).

*Distribution.*—Banff; coast of Cornwall (A. M. N.\*): off Penlee Point, and in Cawsand Bay, Plymouth: Firth of Tay (per W. T. Calman).

Genus *Thysanoessa*, F. Brandt.

*Thysanoessa neglecta* (Kröyer).

*Survey.*—Station 130, Kenmare river, off Sneem, 24 fathoms, mud. March 30th, 1891 (in net attached to trawl, day-time).

Station 144, west of Inishmore, Aran Islands, about 45 fathoms, April 7th, 1891 (in large tow-net, near surface, midnight).

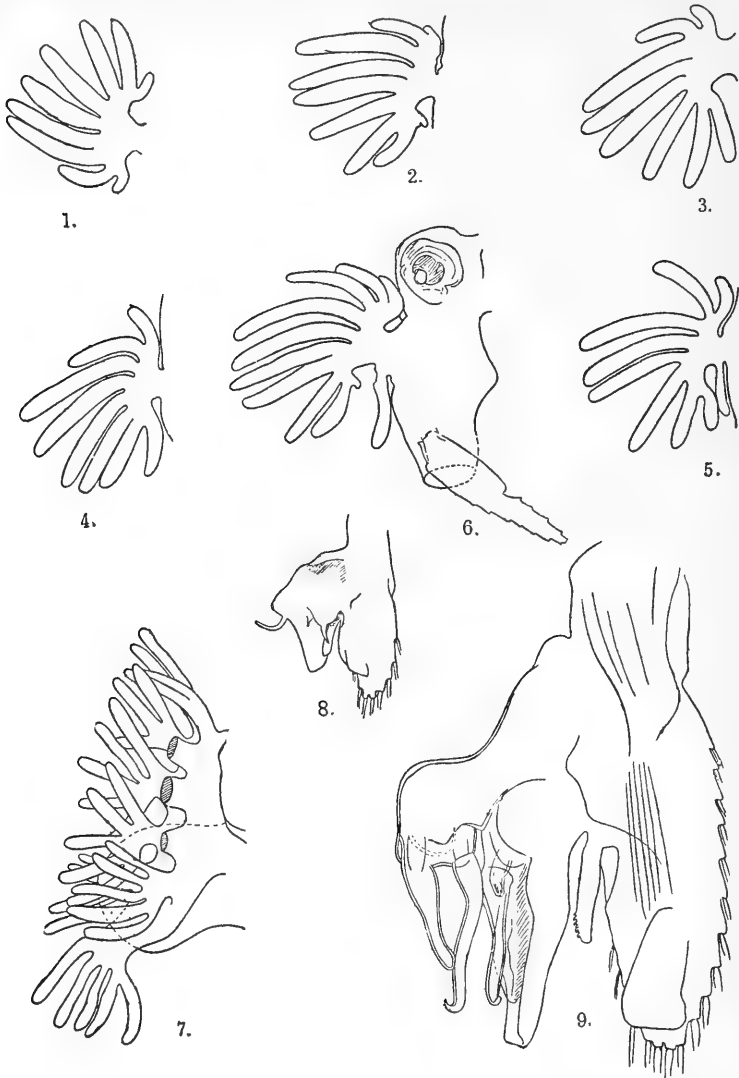

FIGS.

- 1-5. The five anterior gills of the right side of *Nyctiphanes Couchii*, ♂, 12 mm., arranged in the natural order.
6. The sixth gill, with luminous organ and exopodite, of the same specimen.
7. The seventh thoracic appendage of the same specimen. Three of the external gill-plumes have been cut off.

FIG. 1.

FIGS.

8. Inner plate of the first pleopod of the same specimen.
9. Inner plate of the first pleopod of *Nyctiphanes norvegica*, ♂, 35 mm., from Upper Loch Fyne.

All figures drawn to the same scale with camera lucida.

The numerous specimens of St. 144 were taken while the S.S. "Harlequin" was tending on some local boats engaged in experimental mackerel-fishing. Some mackerel were caught, but their food was not examined.

*Marine Laboratory.*—4 miles west of High Island, Co. Galway, surface and bottom tow-nets at night, 16th June, 1899, and very common in stomachs of mackerel from surface drift-nets about the Bofin islands during the same month.

*No Previous Irish Record.*

*Distribution.*—Aberdeen; Firth of Forth; Loch Seaforth (A. M. N.\*): off Hebrides; mouth of English Channel (Ortmann).

Norway; Finmark; Siberia; N.E. America (A. M. N.\*): Bay of Biscay (Caullery).

Genus—**NEMATODACTYLUS**, Calman.

**Nematodactylus bööpis**, Calman.

CALMAN, Trans. R. I. Acad., xxxi., 1896, p. 17, Pl. II.

Off S.W. of Ireland, 1020 fathoms (Calman).

The species is not definitely British, as Norman's limit is the 1000 fathoms line. It is mentioned here for purposes of convenience.

Genus—**EUCOPIA**, Dana.

**Eucopia australis**, Dana.

CALMAN, Trans. R. I. Acad., xxxi., 1896, p. 15.

Off S.W. of Ireland, 1020 fathoms (Calman).

This is a cosmopolitan species from the deep water of the oceans; Calman considers that its occurrence at or near the surface must be regarded as exceptional. It has not yet been taken actually within the limits of the British area.

Family.—**MYSIDÆ**.

Sub-family.—**SIRIELLINÆ**.

Genus **Siriella**, Dana.

**Siriella Clausii**, G. O. Sars.

*Not in the Survey Collection.*

*Marine Laboratory.*—Blacksod Bay, 29th March, 1899, 6–8 fathoms; Inisbofin Harbour, 4th to 18th August, 1899, very common in surface and midwater nets at night, but not found, perhaps on account of abundance of drift-weed, during the day.

*Previous Irish Record.*—S.E. of Ferry pier, Valentia Harbour (A. O. W.\*)

*Distribution.*—Loch Fyne (A. M. N.\*): off Plymouth.†

Mediterranean (A. M. N.\*).

† A *Siriella* of rather abnormal character, from Start Bay, is also probably referable to this species.

**Siriella armata** (Milne-Edwards).

*Siriella intermedia*, Gourret, Ann. Mus. Hist. Nat. Mars., iii., 1889, Mem. v., p. 183, Pls. xvii, xviii.

*Survey*.—Blacksod Bay, August 6th, 1890.

Station 145, Killeany Bay, Aran, April 8th, 1891.

Killeany Bay, July 26th, 1890.

*Marine Laboratory*.—Mouth of Killeany Bay, 25th March, 1899; Blacksod Bay, 29th March, 1899; Ballynakill Harbour, 15th May, 1899; Bofin Harbour, August, 1899 (common among weeds, but only one young example in tow-net with *S. Clausii*).

*Museum, Dublin*.—No. 195, 1895. Roundstone.

*Previous Irish Record*.—Valentia Harbour (A. O. W.\*).

*Distribution*.—E. and W. Scotland; Isle of Man; S. and S.W. England (A. M. N.\*): Irish Sea (A. O. W.).

Trieste, Goletta (A. M. N.\*): Marseilles (Gourret): Brittany; Gulf of Lyons (Pruvot): off Vlieland, North Sea (Ehrenbaum). Jersey (A. M. N.\*).

We have recently shown (*Ann. Mag. Nat. Hist.*, s. 7, March, 1899, p. 151) that British records of *S. frontalis* refer in reality to *S. armata*, there being no evidence of the occurrence of the former within the British area. The variability of certain characters, noted in Plymouth examples of *S. armata*, is equally present in Irish specimens.

We believe that *S. intermedia*, Gourret, from Marseilles, is separated by its discoverer from *S. armata* on quite insufficient grounds. The least unimportant distinction that we can discover in the text is the relative shortness of the rostrum; but this disappears in the light of Gourret's own remark (*op. cit.*, p. 182) that Marseilles examples of *S. armata* have a shorter rostrum than is figured by Sars.

Pruvot, who enumerates in his list both *S. armata* and *Mysis Griffithsiae*, Bell, may intend thereby to convey the intimation that he rejects Norman's view of the identity of these species with each other. On the other hand the entry may be no more than evidence of carelessness of compilation.

Sub-family.—GASTROSACCINÆ.

Genus **Gastrosaccus**, Norman.

**Gastrosaccus spinifer** (Goëss).

*Survey*.—Station 223, Loughrosmore Bay, 9 to 4 fathoms, sand. May 21st, 1891.

*Marine Laboratory*.—Blacksod Bay, 29th March, 1899.

*Museum, Dublin*.—No. 195, 1895. Roundstone.

*Previous Irish Records*.—Port Magee entrance, Valentia Harbour (A. O. W.\*): at surface, off N. and N.E. Ireland (Herdman).

*Distribution*.—E. and W. Scotland; Whitby; Starcross (A. M. N.\*): Dogger Bank (T. S.): Irish Sea (A. O. W.).

Sweden; Denmark; mouth of the Seine (A. M. N.\*): Heligoland, coasts of Germany and S. Norway (Ehrenbaum): Channel Islands (Walker and Hornell).

#### **Gastrosaccus sanctus** (Van Beneden).

*Survey*.—Station 145, Killeany Bay, Aran. April 8th, 1891.

*Marine Laboratory*.—Mouth of Killeany Harbour, 25th March, 1899; off Bofin Harbour, 17 fathoms, 17th July, 1899; Bofin Harbour, 4th and 5th August, 1899, common in surface tow-nets at night, but only one specimen found, in a bottom net, during the day time.

*No Previous Irish Record*.

*Distribution*.—Irish Sea (A. O. W.): Plymouth (W. Garstang!): Jersey (A. M. N.\*).

Belgium; Boulogne; Naples; Goletta (A. M. N.\*): Black Sea; Sea of Azov (Sowinski, 1894, 1895).

Most of the specimens from Bofin have practically no trace of the upturned processes of the hind margin of the carapace, though agreeing in other respects with the type. The same peculiarity has been observed in material from Plymouth, and appears to require further attention.

#### Genus **Haplostylus**, Kossmann.

This genus is distinguished from *Gastrosaccus* by the rudimentary condition of the inner branch of the third pleopod of the male. Forwardly directed lobes of the posterior margin of the carapace are invariably absent.†

#### **Haplostylus Normani** (G. O. Sars).

*Gastrosaccus Normani*, G. O. Sars, *et auct.*

*Not in the Survey Collection*.

*Irish Record*.—Off Valentia (A. M. N.\*).

*Distribution*.—Rockall (A. M. N.\*). Plymouth.

Mediterranean (A. M. N.\*).

† We are indebted to Mr. W. T. Calman for the reference on which our diagnosis is founded.

Genus **Anchialus**, G. O. Sars.

**Anchialus agilis**, G. O. Sars.

*Survey*.—Station 118, Ballinskelligs Bay, 32 to 28 fathoms, soft mud. August 21st, 1890.

Station 121a, off Ballycottin, 41 fathoms, sand. August 28th, 1890.

*No Previous Irish Record.*

*Distribution*.—Plymouth (A. M. N.\*!).

Naples; Messina (A. M. N.\*): Channel Islands (Walker and Hornell).

Sub-family.—HETEROMYSINÆ.

Genus **Heteromysis**, S. I. Smith.

**Heteromysis formosa**, S. I. Smith.

*Not in the Survey Collection.*

*Irish Record*.—Valentia Harbour, shore (A. O. W.\*).

*Distribution*.—Firth of Forth, Guernsey (A. M. N.\*). Plymouth (W. Garstang!).

Norway; coast of United States (A. M. N.\*).

Sub-family.—LEPTOMYSINÆ.

To include a new-comer, *Parerythrops obesa*, G. O. Sars, Norman's synopsis of this sub-family may conveniently be altered by substituting "*Male with at least the second to fifth pairs of pleopods greatly developed and adapted for swimming,*" for "*male with all the pleopods, etc.*"

Genus **Erythrops**, G. O. Sars.

**Erythrops serrata**, G. O. Sars.

*Survey*.—Station 115, off the Skelligs, 62 to 52 fathoms, mud and sand. August 20th, 1890.

Station 143, west of Inishmore, Aran, 46 to 44 fathoms. April 7th, 1891.

Station 125, 40 miles west of Bolus Head, 115 fathoms. March 23rd, 1891.

The contents of the surface and bottom tow-nets of Station 125 were accidentally mixed. Obvious derivatives of the bottom are sand, small crabs, and bivalve shells. Two much-damaged Schizopods are almost certainly also from the bottom. One of them, a headless, limbless, and macerated specimen, with a broken telson, is

only recognisable from one of the inner uropods, which has the inner margin finely serrulated throughout. This character appears to be confined to *E. serrata*. In other respects the uropod conforms equally to this species.

*Previous Irish Records*.—Off Valentia, 80 to 100 fathoms (A. M. N.\*): Mr. A. O. Walker has recorded the species from Station 115, having no doubt received specimens accidentally mixed with Amphipods, etc., from the same haul.

*Distribution*.—Shetland; Moray Firth; Firth of Forth (A. M. N.\*): Loch Fyne (T. S.): Irish Sea (A. O. W.).

Norway, 30 to 200 fathoms (G. O. S.): Denmark (A. M. N.\*).

It would appear, from the examination of Irish specimens, that existing descriptions of this species require modification. We find that the serrulation of the inner uropod, a character hitherto held to be of unreservedly specific value, is by no means constant; but is, in fact, practically confined to females and immature males.

In females, of which thirty were examined, the serrulation was invariably well-marked.

In the male it appears to be lost with maturity, as testified by the perfection of the pleopods, and particularly by the full development of the setæ of the copulatory process of the antennule.

Thus, of fifty-six males, twenty-four are devoid of serrulation on the inner uropods, and twenty of these, in which the antennules remain uninjured, have the setæ fully developed.

The remaining thirty-two males have the inner uropod serrulated; in twenty-five the setæ of the antennule are undeveloped; in two the setæ are minute; in one the setæ are about half-grown. In the remaining four the antennules are not available. A length of 10 mm., from the tip of the antennal scale to the extremity of the uropod, approximately represents, for our specimens, the greatest length of males with serrulated uropods.

We considered it possible that the above remarks might be of purely local application, the absence of serrulation being a racial, rather than a specific, character. Sars' figures (Monogr. over Mysider, Tab. II.) could not be taken as evidence, since it was not certain that the serrulated uropod of his figure 11 was taken from the same individual of which the anterior parts, with fully developed setæ, are shown in his figure 10. However, we have since found in the Museum some specimens of *E. serrata* from the Asbjornsen collection, which appear to have been named by Professor Sars himself. One of them is a mature male, and its inner uropods are as innocent of serrulation as in the case of examples from the West of Ireland. The Asbjornsen specimens are from Lofoten. (See Note, p. 250.)

It is possible that these facts are quite familiar to Professor Sars, but if he has published any modification of his original diagnosis, it has escaped our notice.

Genus **Parerythrops**, G. O. Sars, Monog. over Mysider, Pt. I.,  *nec*  Pt. III.

**Nematopus**, G. O. Sars.

*Eyes* short, not flattened, nearly globose, remote from each other; pigment of dull fulvous colour, not soluble in spirits. *Antennal scale* very short; external margin not ciliated, terminating in a spine-point. *Legs* of moderate length, rather robust; tarsi of (about?) three articulations, besides the stout nail. *Telson* elongate, sub-triangular; lateral margins entire; apex narrowly truncate, beset with four slender spines and two setæ. *Pleopods* in female small, simple; in male first pair small, simple; remaining pairs biramous, natatory. (Abbreviated from G. O. Sars.)

**Parerythrops obesa**, G. O. Sars.

Pl. XVI, figs. 2, 3.

**Parerythrops obesa**, G. O. Sars, *Carcinolog. Bidrag. Norg. Faun.*, I.  
Monog. over Mysider, 1870, p. 41.

*Carapace* of about equal horizontal width throughout, the greatest width being much more than half the length; anterior margin produced so as to form nearly a right angle. *Pleon* less than half as wide as cephalothorax, its last segment longer than the others. *Eyes* large, sub-globose; internal margin but slightly emarginate. *Antennule*, peduncle a little longer than the eye; its distal articulation longer than the united length of the two proximal. *Antennal scale* a little longer than peduncle of antennule, sub-rhomboidal, about three times as long as wide; outer margin terminating in a spine, beyond which the linguiform apex is produced so as to occupy nearly half the length of the scale. *Telson* nearly equal in length to the last segment of abdomen; elongate, sub-triangular, greatest width much less than length; lateral margins nearly straight; apex very narrow, squarely truncate; outer pair of terminal spines not half as long as the inner pair. *Uropods*, outer about one-third longer than inner; the latter with about 20 strong spines occupying the greater part of its inner margin. *Pigment* of adult bright red. *Length* of adult female about 13 mm., of male about 14 mm. (After G. O. Sars.)

*Survey*.—Station 115. Off the Skelligs, 62 to 52 fathoms, mud and sand. August 20th, 1890.

*No Previous British Record.*

*Distribution*.—Norway; Lofoten; Finmark, 30 to 200 fathoms (G. O. S.).



The species is added to the British Fauna on the evidence of a single female, so much battered that some of the generic characters cannot be observed. The telson, however, remains available, and is of a form only met with, so far as we know, in the genera *Parerythrops* and *Metererythrops* (*vide* figs. 2, 3).

In distinguishing between the three known species, *P. obesa*, *M. robusta*, S. I. Smith, and *P. abyssicola*, G. O. Sars, the small size of the eyes in the last named is a very obvious character. The two first have large eyes of about the same size and form. So far as we can determine, in the absence of the adjacent appendages, and from the defective condition of the cephalothorax, the eyes in our specimen are too large to permit of its being assigned to *P. abyssicola*. Moreover, the outline of the faceted area agrees, on the testimony of Sars' figures, rather with *P. obesa* than with *P. abyssicola*. While in other characters the latter closely resembles *P. obesa*, *M. robusta* differs from either in having a much more elongate telson. In our specimen it is about equal to the last segment of the abdomen; in *M. robusta* it is about one-third as long as the entire pleon. Minor differences observed by Sars in the characters of the antennules, antennal scales, and legs are of no use to us, as our specimen has lost all these appendages.

*P. obesa* and *P. abyssicola* are not separated by any very well-marked characters of the telson, but, although the lateral margins of this structure are rather more curved than in Sars' figure of *P. obesa*, they agree with that species rather than with *P. abyssicola*. The proportions of the terminal spines are also in harmony with *P. obesa* rather than with *P. abyssicola* (*cf.* Sars, *op. cit.*, Pl. III., fig. 18, Pl. XXVIII., figs. 9, 10, Pl. XXIX., figs. 7, 8).

The single inner uropod which remained entire in our specimen was broken in manipulation, but has been carefully reconstructed by Mr. Green (fig. 3). At present it has fewer spines than in any of Sars' species, but some have almost certainly been broken off.

#### Genus *Mysidopsis*, G. O. Sars.

#### *Mysidopsis didelphys* (Norman).

*Survey*.—Station 115. Off the Skelligs, 62 to 52 fathoms, mud and sand. August 20th, 1890.

Station 125. 40 miles west of Bolus Head, 115 fathoms. March 23rd, 1891.

We have already mentioned, under *E. serrata*, the accidental mixing of the contents of the bottom and surface nets of Station 125. The bottle contains a mangled specimen, apparently a *Mysidopsis*, and probably referable to this species. The total length is about 7 mm. The cephalo-thoracic shield is displaced; the trunk is much macerated; the legs have disappeared, except the

exopodite of one. The eyes are large, of a pale reddish colour. What remains of one antennal scale has the characters of the genus. The pleopods are simple. The telson is broken off rather short, but the proximal spines of the lateral margins are rather few, as in *M. didelphys* rather than *M. angusta*. There is a single spine on the ventral side of the oteocyst, a character common to these two species. The size of the eyes, the lateral margins of the telson, and the somewhat robust form of the whole animal are sufficient, as we think, to justify our determination.

From Station 115, in addition to sixteen mature and half-grown specimens, we have two which are quite small. They can be referred without difficulty to the same species as the larger ones, and serve, by comparison, to confirm our determination of the mangled example from Station 125. *M. didelphys* is recorded by Sars from 50 to 150 fathoms, whereas *M. angusta* has not yet been taken below the 50 fathom line.

*Previous Irish Record.*—Off Valentia (A. M. N.\*).

*Distribution.*—Shetland; Firth of Clyde; Loch Fyne; Moray Firth; Firth of Forth; off Tynemouth (A. M. N.\*).

Norway; Denmark (A. M. N.\*).

#### ***Mysidopsis gibbosa*, G. O. Sars.**

*Survey.*—Station 118, Ballinskelligs Bay, 32 to 28 fathoms, soft mud. August 21st, 1890.

*Marine Laboratory.*—Fahy Bay, Ballynakill, 5th March and 18th May, 1899.

*Museum, Dublin.*—No. 195, 1895. Roundstone.

*Previous Irish Records.*—Valentia (A. M. N.\*): Valentia Harbour (A. O. W.\*).

*Distribution.*—Loch Fyne; Firth of Forth (A. M. N.\*): Plymouth (W. Garstang!); Start Bay; Irish Sea, Port Erin (A. O. W.).

Norway; Denmark; Mediterranean (A. M. N.\*).

#### ***Mysidopsis angusta*, G. O. Sars.**

*Survey.*—Station 118, Ballinskelligs Bay, 32 to 28 fathoms, soft mud. August 21st, 1890.

Station 148, 7 miles S.S.W. of Gregory Sound, Aran, 38 fathoms, sand. April 9th, 1891.

*Previous Irish Record.*—Valentia Harbour (A. O. W.\*).

*Distribution.*—E. and W. Scotland (A. M. N.\*): Dogger Bank (T. S.): Start Bay, and off Plymouth.

Norway; Naples (A. M. N.\*).

**Mysidopsis hibernica**, Norman.

Pl. XVI., figs. 4, 5.

*Survey*.—Station 115, off the Skelligs, 62 to 52 fathoms, mud and sand. August 20th, 1890.

[ *Previous Record*.—Valentia (A. M. N.\*).

The species has hitherto been known from a pair of examples captured by Norman in Dr. Jeffrey's yacht "Osprey," at Valentia in 1870. No note was made of the "circumstances as to the depth, etc.," under which they were obtained, so that our record furnishes the first exact information on this point. The length is given by Norman as 15 mm. Our solitary example is considerably smaller; and, if only young examples were present at the time we were fishing, many may have escaped through the meshes of the mosquito-net bag. As usual, the anterior appendages are rather defective, the antennal scales having disappeared, and the antennules being more or less denuded of setæ. Hence the characters of these appendages are not available for specific diagnosis. The telson and the inner uropod (figs. 4, 5) are, as we think, in sufficiently close agreement with Norman's diagnosis (*Ann. Mag. Nat. Hist.*, s. 6, October, 1892, p. 165, pl. ix., figs. 2, 3, 4) to warrant us in referring the specimen to *M. hibernica*. It will be noticed, however, that the apex of the telson diverges slightly from the type. In Norman's figure there is shown but a slight emargination of the posterior border between the inner pair of terminal spines, whereas Mr. Green's drawing shows that the Skelligs specimen has a distinct notch in this position; while the terminal spines (the longer of which have lost their points) are by no means symmetrical. Slight variations and abnormalities of this structure must be quite familiar to every student of the family. If Norman's figures 2 and 3 (*loc. cit.*) are drawn to the same scale, the telson must, relatively to the length of the inner uropod, be rather shorter in the Skelligs example than in the type. We believe that we have evidence, from the analogy of other members of the family, that such a difference is often explicable by the size of the specimens, the length of the telson tending to increase with age. In our specimen the lateral margins of the telson have fewer spines than are shown in Norman's figure, as, indeed, might be anticipated from its small size (*cf.* especially *Schistomysis spiritus*).

The typical structure of the telson cannot be held to be certainly known until more specimens have been examined. Although the asymmetry of the Skelligs example suggests abnormality, it is quite possible that a notch in the posterior border is more usual than a simple emargination.

Genus **Leptomysis**, G. O. Sars.

**Leptomysis gracilis**, G. O. Sars.

*Survey*—Station 118. Ballinskelligs Bay, 6 fathoms, sand. 21st August, 1890.

Station 121a. Inside the Nymph Bank, off Ballycottin, 41 fathoms, sand. 28th August, 1890.

Station 130. Kenmare river, off Sneem, 24 fathoms, mud. 30th March, 1891.

*No Previous Irish Record.*

*Distribution.*—E. Scotland; Shetland (A. M. N.\*): Plymouth (W. Garstang!).

Norway; Boulonnais, France (A. M. N.\*): North Sea, central parts (Ehrenbaum).

*L. gracilis* does not figure in Walker's records from the Irish Sea, so that a considerable gap occurs in the recorded distribution of this species on the British coasts. On the south and east coasts of England the gap is possibly due to want of observation, but it is much less likely that any Schizopod, abundant on the W. coast of England and Scotland, should escape the attention of Mr. Walker and Mr. Thomas Scott.

An abnormal example in the Irish collection has one large median terminal spine on the telson, and two large postero-lateral spines, which each appear to have been separated from the median by one (possibly two) small spines, now missing. Many lateral spines have been lost by the telson, and the antennal scales are imperfect, but the hispid skin and characteristic rostrum sufficiently associate the specimen with *L. gracilis*.

**Leptomysis mediterranea**, G. O. Sars.

*Survey*—Station 145. Killeany Bay, Aran. 8th April, 1891.

A single specimen, 18 mm. long, caught in a small calico trawl. The large number of setæ on the distal joints of the antennal scales is noteworthy = 12 on the internal, 16 on the external border.

*Marine Laboratory.*—Mouth of Killeany Bay, 25th March, 1899.

*No Previous Irish Record.*

*Distribution.*—Channel Islands; Starcross, Devon (A. M. N.\*): Plymouth (W. Garstang!).

Spain; Mediterranean (A. M. N.\*): Heligoland (Ehrenbaum).

**Leptomysis lingvura**, G. O. Sars.

*Leptomysis Marioni*, P. Gourret, "Revision d. Crust. podophthalm. Golfe de Marseille."—Ann. Mus. Hist. Nat. Marseille, III., 1889, Mem. v., p. 185; pl. xviii., figs. 8-14.

*Survey*.—Station 118. Ballinskelligs Bay, 32 to 28 fathoms, soft mud. 21st August, 1890.

*Museum, Dublin*.—No. 195, 1895. Roundstone.

*Previous Irish Records*.—Lough Kay, Valentia; Dingle Bay (A. O. W.\*).

*Distribution*.—Firth of Forth (T. S.): Loch Fyne; Northumberland; Durham; Starcross (A. M. N.\*): Irish Sea, Port Erin and Colwyn Bay (A. O. W.): Plymouth.

Norway; Boulonnais; Mediterranean; Black Sea (A. M. N.\*): N.-W. France (Pruvot. *L. Marioni*).

While *Leptomysis sardica* (G. O. Sars) is considered by Norman to be merely a small race of *L. lingvura*, it would appear, from the remarks of the same observer, that typical examples of the latter occur in the Mediterranean (Adriatic), as well as in the Atlantic. We see no reason to doubt the accuracy of Norman's views as to the identity of the two species.

We further believe that *L. Marioni*, of Gourret, is not to be distinguished from *L. lingvura* by any characters of specific moment. It does not appear that the author was acquainted with Sars' Norwegian monograph, nor is it certain that the distinctions which are drawn between *L. sardica* and *L. Marioni* are based on the examination of a series of the latter sufficiently numerous to eliminate the probability of the occurrence of intermediate varieties. *L. sardica* appears to have been known to Gourret only from the figures of Sars, and in the case of an appendage not figured for *L. sardica*, comparison has been somewhat futilely instituted with *L. mediterranea*. The mandible is figured and compared with that of *L. mediterranea*, as figured by Sars. The difference would be the more remarkable if Gourret's drawing were not obviously taken from a specimen distorted in manipulation. In the position in which they are shown the anterior denticulations of the cutting edge have no very obvious function. We have examined the mandibles of *L. lingvura*, and consider it possible that Gourret's figure 8, pl. xviii., may have been based on a distorted appendage of similar structure. The anterior denticulations, though very different in position, are not widely dissimilar from those of *L. Marioni* (as figured). The distinctive characters of the outer process of the antennule in *L. Marioni* do not appear to us of much importance, and, in so far as concerns the length of the first joint of the process, Gourret's species would seem to resemble *L. lingvura*.

We suppose that a comparison of the first maxillæ of *L. Marioni* and *L. sardica* contains a clerical error, whereby the latter species has been substituted

for *L. mediterranea*, since Sars neither figures this appendage of *L. sardica* nor includes a description of it in the diagnosis of the species.

With regard to the second maxilla *L. mediterranea* is the species selected for comparison. The differences noted as distinguishing *L. Marioni* are less strongly marked, as far as Gourret's figure appears from the whole context to be reliable, when the last-named species is compared with *L. lingvura*. The outer processes (fouets) of the second maxillæ of a specimen examined are somewhat conical, and have but few marginal setæ.

The maxillipeds are stated to differ slightly from those of *L. mediterranea*, but in the case of the second pair such difference appears only to bring them more into conformity with *L. lingvura*.

The inner uropod of *L. Marioni*, if notably different from that of *L. sardica*, is certainly distinguishable from that of *L. lingvura* in no important particular.

The spinulation of the telson in *L. Marioni* is undoubtedly different from that which typically obtains in *L. lingvura*. In the latter there are two (in *L. sardica* three) small median spines, bordered by a large spine on each side. Each large spine is separated laterally from another large spine by three (in *L. sardica* four) smaller ones. In *L. Marioni* there are eight small median spines, of which the two most central are rather larger than the rest. Lateral to these on either hand are two large spines separated by seven smaller ones. The difference in size between the larger and smaller spines is much greater in *L. Marioni* than in *L. lingvura*; and the distinction between the two forms in this particular is, in effect, that the four large spines of the extremity of the telson are separated by more numerous and smaller spinules in *L. Marioni* than in *L. lingvura*.

The analogy of other forms, notably *Siriella armata*, inclines us to distrust most strongly the specific value of such a distinction, based on the examination of an unknown and possibly small number of examples; the more especially since the supposed differences in other parts appear altogether trivial, not to say illusory. *L. Marioni* may therefore be relegated, for the present, to the synonymy of *L. lingvura*, or may, at most, be held to be a race of the latter characterised by difference of the number of spinules on the terminal portion of the telson.

Sub-family.—MYSINÆ.

Genus **Hemimysis**, G. O. Sars.

**Hemimysis Lamornæ** (Couch).

*Not in the Survey Collection.*

*Marine Laboratory*.—Blacksod Bay, 6-8 fathoms, 29th March, 1899. Two specimens, pigment bright red.

*No Previous Irish Record.*

*Distribution*.—Falmouth; Plymouth; Seaham; N. Wales; E. and W. Scotland (A. M. N.\*).

Norway; Sweden; Denmark; Naples; Black Sea (A. M. N.\*).

Genus **Macropsis**, G. O. Sars. (See Note added in Press, p. 250.)

Genus **Macromysis**, A. White.

**Macromysis flexuosa** (Müller).

*Not in the Survey Collection.*

*Marine Laboratory*.—Aran; Blacksod Bay; Ballynakill; Inisbofin; 1899.

*Museum, Dublin*.—No. 85, 1893, Bantry Bay, per A. R. C. Newburgh.

No. 122, 1892, Bantry Bay.

No. 122, 1892, Dunbeacon Harbour, Bantry Bay.

No. 122, 1892, S.W. of Ireland.

Unregistered. Dunbeacon Harbour; Broadhaven, 1873; Merrion, Co. Dublin, per G. Y. Dixon.

*Previous Irish Records*.—"All our coasts" (A. M. N.\*).

*Distribution*.—British coasts.

Atlantic coasts of the European continent; Baltic; Black Sea (?), (A. M. N.\*).

Of all British Mysidæ with which we are acquainted, the genus *Macromysis* appears to present the greatest difficulty in the determination of the species, on account of the unsatisfactory nature of the characters by which *M. flexuosa* and *M. neglecta* have been separated by Sars and Norman. Were it not for the high authority of these observers, we might be inclined, with little ceremony, to relegate one species to the synonymy of the other, a proceeding hardly justified by our experience of the family. We must, however, admit that we have never seen a really typical specimen of *M. neglecta* as redefined by Norman. The distinctive characters of the two may be summarised (from Norman) as follows:—

*M. neglecta*.

*M. flexuosa*.

*Antennal scale*.—*Ca.* 5 times as long as broad; not twice the length of peduncle of antennule; apex extending twice the length of spine of external margin.

7 to 8 times as long as broad; more than twice the length of peduncle of antennule; apex scarcely extending beyond spine.

*Tarsus*.—5-articulate, last 4-articulate.

6-articulate, last 5-articulate.

*Telson*.—Cleft  $\frac{1}{2}$  of total length, very narrow and constricted at base; 18 to 20 lateral spines.

Cleft  $\frac{1}{3}$  of total length, moderately open; 21 to 27 lateral spines.

*Length*.—20 mm.

25 mm.

The above characters, if constantly found associated in individuals, would certainly enable us to name specimens either *M. flexuosa* or *M. neglecta*, leaving to higher authorities the task of deciding whether or no the somewhat minute differences enumerated were really of specific moment. However, in the Irish examples, the characters prove to be mixed in individuals or compromised by the occurrence of intermediate conditions.

The number of joints in the tarsus has the appearance, on paper, of a well-defined character, and it may be easy for an expert to count the joints in all examples. We ourselves have often experienced the greatest difficulty in this matter, since the proximal articulation is often so faintly indicated, even under a moderately high power, that it is impossible to decide whether it is entitled to rank. Moreover, the number of joints often varies in the anterior legs of the same individual, as may be seen by the following figures:—

*Articulations of tarsus of legs, from in front backwards.*†

Specimen.	Specimen.
A. 6, 6, 6, 5, 5, 4.	I. 5, 5, 6, 5, 5, 4.
B. 5, 5, 6, 5, 5, 4.	J. x, x, $\frac{6}{6}$ * x, 5 (?), $\frac{4-5}{4}$ (??).
C. 5, 6, 6, 6, 5, $\frac{5}{5}$ .	K. An anterior leg, 4.
D. 5-6 (?), x, $\frac{6}{6}$ , 6, 6, 5.	L. $\frac{5}{5}$ , $\frac{5}{5}$ , x, 5, 4.
E. 5, $\frac{5-6}{6}$ (?), 6, 5-6 (?), 5, 4-5 (??).	M. 4-5 (?), 5, 5, 5, 5 (?), $\frac{4}{4}$ .
F. 5, 5-6 (??), 5-6 (?), 5, 5, 4.	N. x, 5, a leg anterior to last 4.
G. 5, 6 (?), 6 (?), 5, 5 (?), 4.	

If the presence of a sixth articulation is a crucial point of distinction, A to J must be *M. flexuosa*, while L to N are *M. neglecta*. The specimens are enumerated in the order of size, A to K measuring 24 to 15 mm. (including antennal scales and telson); L to M 13 to 12 mm. In the case of *Schistomysis ornata*, Norman, in deciding *P. Keruillei* to be a synonym of the first-named species, attaches no importance to the extra joint of the tarsus present, but apparently not invariably, in large specimens. We cannot see why the character should have greater value in *Macromysis*, in which, indeed, we have given some little evidence that the number of joints may increase with the age or size of the specimen; although since M and N are fully developed males, it be not correlated to sexual maturity.

† Two figures separated by a hyphen and followed by a note of interrogation indicate that the existence of the larger number of articulations (six in 5-6?) is doubtful. The doubt is greater where two notes of interrogation are employed. A single figure followed by a note of interrogation means that the proximal articulation was observed, but only indistinctly formed. Figures shown as fractions ( $\frac{5}{5}$ ) refer to a pair of legs.



The relations of the antennal scale to the peduncle of the antennule give results as follows:—A. antennal scale fully double the length of the peduncle of the antennule; C. distinctly more than double; D. about double; E. barely double; F. somewhat less than double; G. barely double; H. about double; I. distinctly less than double; J. scales both perfect, but of unequal length: the longer one about double the length of the peduncle of antennule; K. slightly less than double; M. slightly less than double; N. distinctly less than double.

The relative length and breadth of the scale can only be ascertained by isolating this appendage. In the few cases in which this has been done, the breadth has proved to be about one-sixth of the length. Such a proportion is intermediate between the conditions of *M. flexuosa* and *M. neglecta*. In shape, on comparison with Sars' figures, the antennal scale appears to incline to the condition of the last-named species. Specimens C and D have the apex of the scale as in *M. flexuosa*; in A the shape is intermediate; in B and K the scale is imperfect; in the remaining specimens the shape approaches *M. neglecta*. But, as far as one can judge without detaching the scale, the width is in all cases intermediate.

At what point of constriction the cleft of the telson may be held to incline to one species rather than to the other is difficult to decide, but comparison with Sars' figures appears to range our examples as follows (the fraction indicates the length of the cleft in the total length of the telson):—

A. ca. $\frac{1}{5}$ “ <i>neglecta</i> ”;	F. $\frac{1}{5}$ “ <i>neglecta</i> ”;	K. $\frac{1}{6}$ “ <i>flexuosa</i> ”;
B. ca. $\frac{1}{5}$ “ <i>neglecta</i> ”;	H. intermediate;	L. $\frac{1}{7}$ “ <i>flexuosa</i> ”;
C. $\frac{1}{5}$ to $\frac{1}{6}$ “ <i>neglecta</i> ”;	I. $\frac{1}{6}$ ;	M. $\frac{1}{5}$ ;
E. $\frac{1}{6}$ “ <i>flexuosa</i> ”;	J. $\frac{2}{11}$ ( $\frac{1}{6}$ );	N. ca. $\frac{1}{5}$ “ <i>flexuosa</i> .”

The lateral spines of the telson are:—

A. $\frac{20}{21}$ ;	E. 21;	H. 22;	K. 22;	N. $\frac{20}{21}$ .
B. 24;	F. $\frac{23}{23}$ ;	I. $\frac{24}{24}$ ;	L. $\frac{20}{21}$ ;	
C. 22;	G. $\frac{21}{22}$ ;	J. $\frac{20}{21}$ ;	M. $\frac{20}{23}$ ;	

The preceding details may be summed up in a table showing to which species the individuals incline in the characters of different parts.

	Length in mm.	Tarsus.	Antennal scale compared with peduncle of antennule.	Shape of antennal scale (not width).	Length of cleft of telson.	Shape of cleft of telson.	Lateral spines of telson.
A. ♀	24	"flex."	intermed.	intermed.	"negl."	"negl."	intermed.
B. ♀	23	"flex."			"negl."	"negl."	"flex."
C. ♀	23	"flex."	"flex."	"flex."	intermed.	"negl."	"flex."
D. ♀	22	"flex."	intermed.	"flex."			
E. ♀	18	"negl."	"negl."	"negl."	"flex."	"flex."	"flex."
F. ♀	18	"flex."	"negl."	intermed.	"negl."	"negl."	"flex."
G. ♀	17	"flex."	"negl."	"negl."			"flex."
H. ♀	16		intermed.	"negl."		intermed.	"flex."
I. ♀	16	"flex."	"negl."	"negl."	"flex."		"flex."
J. ♀	15	"flex."	"negl."		"flex."		intermed.
K. ♂	14	"negl."(?)	"negl."	"negl."	"flex."	"flex."	"flex."
L. ♀	13	"negl."			"flex."	"flex."	intermed.
M. ♂	12	"negl."	"negl."	"negl."	"flex."	"negl."	intermed.
N. ♂	12	"negl."(?)	intermed.	"negl."	"flex."	"negl."	intermed.

The net result appears to us to prove that if *M. flexuosa* and *M. neglecta* have been rightly separated, their distinctive characters have been very imperfectly defined. As the species stand at present, the Irish examples which we have seen are typical of neither. Two characters, those of the tarsus and of the lateral spines of the telson, are almost certainly variable with the size of the example.

#### **Macromysis neglecta** (G. O. Sars).

As appears from our remarks under the preceding, we have great doubts as to the validity of this species.† Our doubts appear to be shared by Ehrenbaum. Specimens have been recorded under this name as follows:—

*Irish Record.*—Valentia Harbour (A. O. W.\*).

*Distribution.*—Loch Fyne; Starcross; Plymouth; North Wales; Guernsey (A. M. N.\*); Irish Sea (A. O. W.).

Norway; Denmark (A. M. N.\*): Heligoland (Ehrenbaum).

† In the museum are four specimens from the Asbjornsen collection (Christiania) named by Professor Sars. We have examined them in so far as was possible without isolating the appendages. They consist of two males, 16 and 17 mm. *ca.*, including antennal scales and uropods, and two females, 17 and 20 mm. In each of the four we have found at least one leg with the tarsus 6-articulate. The two males have 22 lateral spines on the telson, a number in excess of that assigned to the species by Norman, but perhaps,

**Macromysis inermis** (Rathke).

*Not in the Survey Collection.*

*Marine Laboratory.*—Inisbofin Harbour, 4th and 5th August, 1899, surface tow-net at night. Young examples, apparently referable to this species.

*Irish Record.*—Valentia Harbour (A. O. W.\*).

*Distribution.*—Shetland; east and west coasts of Scotland; Northumberland; Plymouth (A. M. N.\*); North Wales; Isle of Man (A. O. W.).

Norway; Sweden; Denmark; Baltic; Murman Sea; Spitzbergen (A. M. N.\*); Heligoland (Ehrenbaum).

Genus **Schistomysis**, Norman.**Schistomysis spiritus**, Norman.

*Survey.*—Station 115, off the Skelligs, 62 to 52 fathoms, mud and sand. August 20th, 1890.

Station 223, Loughrosmore Bay, Co. Donegal, 9 to 4 fathoms, sand. May 21st, 1891.

*No Previous Irish Record.*

*Distribution.*—Shetland; Durham; Banff; Firth of Forth; Jersey (A. M. N.\*); Plymouth (W. Garstang!); Irish Sea, Puffin Island (A. O. W.).

Norway; North Sea; Denmark; Holland; Boulogne, France (A. M. N.\*).

The gathering from Station 223 contains a specimen of 10 mm., and a number of smaller immature forms. The spines of the inner uropod, in the latter, are comparatively few in number and consequently much less crowded than in the adult condition. In the specimen of 10 mm. (and in one of 12 mm. from Plymouth) the spines are still less dense than in the adult, but have the characteristic arrangement. Other characters, which need not be detailed, leave no doubt as to the specific determination.

**Schistomysis ornata** (G. O. Sars).

*Survey.*—Station 118, Ballinskelligs Bay, 32 to 28 fathoms, soft mud. August 21st, 1890.

Station 121*a*, inside the Nymph Bank, off Ballycotton, 41 fathoms, sand. August 28th, 1890.

Station 130, Kenmare River, off Sneem, 24 fathoms, mud. March 30th, 1891.

covered by Sars' diagnosis (20 *ca.*). We have compared the otolith of the larger specimen of each sex with that of a *M. flexuosa* from Christiania Fjord, and are unable to detect any proportional difference in size. In so far as concerns the characters of the antennal scales, and of the cleft of the telson, the determination appears to be in harmony with the descriptions of the two species.

Station 148, seven miles S.S.W. of Gregory Sound, Aran, 38 fathoms, sand. April 9th, 1891.

*Marine Laboratory.*—Blacksod Bay, 6–8 fathoms, 29th March, 1899. Numerous examples, divergent in some characters from the type. We have observed the same peculiarity in specimens from the estuary of the Tamar, and propose to revert to the matter on a future occasion.

*Previous Irish Records.*—Off Valentia (A. M. N.\*): Port Magee entrance, Valentia Harbour, 15 fathoms (A. O. W.\*).

*Distribution.*—Shetland; east Scotland; Durham; Liverpool Bay (A. M. N.\*): Irish Sea (A. O. W.): Dogger Bank (T. S.): off Plymouth and Tamar estuary.

Norway; Denmark; Holland; N. W. France (A. M. N.\*): Baltic, North Sea (Ehrenbaum).

### **Schistomysis arenosa** (G. O. Sars).

*Not in the Survey Collection.*

*Marine Laboratory.*—Off the White Strand, Ship Sound, Inisbofin, 2–5 fathoms, 20th and 22nd July, 1899, very abundant.

*No Previous Irish Record.*

*Distribution.*—Starcross, Devon (A. M. N.\*): Plymouth (W. Garstang!): Mediterranean (A. M. N.\*).

Genus **Mysis**, Latreille.

**Mysis relicta**, Lovén.

*Museum, Dublin.*—Lough Neagh, near mouth of Antrim river, per Dr. R. F. Scharff.

*Previous Irish Record.*—Lough Neagh (A. M. N.\*). *Mysis chamaeleon*, recorded by Bell, on the authority of W. Thompson, from the stomachs of pollen in Lough Neagh, can only be referable to this species.

*Distribution.*—Lakes Venern, Vettern, Malar, etc., Sweden; Lake Mjosen, Norway; Lake Onega, Russia; Lake Ladoga, Putko, etc., Finland; northern part of Gulf of Bothnia; Lakes Michigan and Superior, in America (A. M. N.\*).

Lough Neagh appears to be regarded by geologists as due to a comparatively late subsidence of the basalt of the Bann valley, but the exact period is disputed. It may be presumed that *M. relicta* did not enter the Lough by the navigation canal; it certainly cannot have ascended the Bann, which is in places much too rapid to permit of such an achievement. The most closely allied marine species is *M. oculata*, the sub-Arctic habitat of which is perhaps of some importance in considering the age of the Lough.

Genus *Neomysis*, Czerniavsky.*Neomysis vulgaris* (J. V. Thompson).

*Not in the Survey Collection.*

*Irish Records.*—River Lee, up to Cork and Cove (J. V. Thompson): Belfast Lough (W. Thompson).

*Distribution.*—"All round our coast in brackish water" (A. M. N.\*).

European Atlantic coasts (except Spain and Portugal); Baltic; White and Murman Seas; Black Sea (?) (A. M. N.\*): Bouches du Rhône (A. F. Marion *in litt.*)

*Dasymysis*, gen. nov.

Synon. *Acanthomysis*, Czerniavsky.—*Monogr. Mysid. imprimis Imperii Rossici*, 1882, *Fasc. I.*, p. 134.

*Skin* hispid. *Antennal scale* lanceolate, setiferous on both margins. *Tarsus* with about three articulations and a slender nail. *Telson* linguiform, entire; proximal part of lateral margins naked, or with a few spines near the base; distal parts of margin densely armed with numerous unequal lanceolate spines. In the male, the first, second, and fifth *pleopods* are like those of the female; the third is hardly at all modified; the fourth with a peduncle and two branches, the inner as usual in *Mysinae*; the outer narrowly cylindrical, somewhat flexuous, bi-articulate, the proximal joint elongate, the distal very short and beset with two short subequal setiform flagella.

Type. *Mysis longicornis*, Milne-Edwards.—"Hist. Nat. Crust.," 1837, ii., p. 459, pl. xxvi., figs. 7-9. G. O. Sars—"Middelhav. Mysider," 1877, p. 22, pls. 9, 10, = *Acanthomysis platydens*, Czerniavsky, *op. cit.* p. 137.

The genus *Acanthomysis*, instituted by Czerniavsky, with *M. longicornis* (G. O. Sars) as the type, cannot be retained, since it is stated that the pleopods are as in *Mysis*, the type being thus excluded. The genus *Mysis*, as restricted by Czerniavsky himself, contains the species *M. relicta*, *M. oculata*, *M. mixta*, and several others of more doubtful value. The three which we have named have the pleopods very different from those of *M. longicornis*. The third pleopod of the male has a well-developed basal joint, and two distinct, if short, branches. The fourth pleopod of the male has the outer branch multi-articulate, and much stouter than in *M. longicornis* (*cf.* G. O. Sars, "Monog. over Mysider," pp. 69,

73, 76, pls. xxxi.—xxxiii.). In so far as the pleopods are concerned *M. longicornis* might be included in the genus *Neomysis*, from which, however, it is distinguished by other characters.

***Dasymysis longicornis* (M.-Edw.).**

*Mysis longicornis*, Milne-Edwards, *loc. cit.*

? *Mysis longicornis*, Heller, "Crust. pod. Südl. Europ.," 1863, p. 302.

*Mysis longicornis*, G. O. Sars, *loc. cit.*

*Acanthomysis platydens*, Czerniavsky, *loc. cit.*

*Acanthomysis longicornis*, Czerniavsky, *op. cit.*, "Fasc. III.," p. 75.

*Acanthomysis spinosissima*, Czerniavsky, *op. cit.*, "Fasc. I.," p. 135, pls. xxxi., xxxii.

*Form* narrow and slender, abdomen nearly straight. *Skin* hispid in all parts. *Rostrum* obtusely angular. *Eyes* large, pyriform, widely separate, extending well beyond the lateral margin of carapace. Peduncle of *antennule* rather elongate, the second joint dorsally produced into a forwardly-directed process; the last joint rather tumid and nearly equal in length to the first. *Antennal scale* but slightly extending beyond peduncle of antennule, narrowly lanceolate in form, its extremity divided from the rest by an oblique suture. *Tarsus* about three-articulate, the proximal articulation the longer, nail slender but distinct. *Telson* elongate, entire; widely dilate at the base, thence suddenly constricted; the posterior part narrowly linguiform, and densely armed at the margin with numerous, unequal, lanceolate, straight or slightly curved spines, their extremities with a distinct axial marking.† *Inner uropod* hardly longer than telson, narrowly lanceolate, base swollen; otocyst oval, large; inner margin in region of otocyst beset with a row of spines of gradually increasing size. *Outer uropod* one-fourth longer than inner, very narrow, with a slight outward curve, apex obliquely truncate. Male, with the fourth *pleopod* not reaching the posterior extremity of the sixth segment. *Length* of female scarcely 9 mm. *Pigment* blackish-brown, not abundant.

*Survey*.—Station 118, Ballinskelligs Bay, 32 to 28 fathoms, soft mud. 21st August, 1890.

*Previous Irish Record*.—None.

† The external chitinous sheath of the spine is suddenly thickened towards the distal end, the lumen being thus reduced in such a way as to present the appearance of an axial line. This character (also present in *L. apiops* (?)) appears to have suggested to Mr. Walker that the extremity of the spine is trigonal.

*Distribution*.—Start Bay, Devon: off Plymouth (E. W. L. H. and W. I. B.). Irish Sea (A. O. W.).

Naples (M.-Edw., G.O.S., Czerniavsky): Algeria(?) (Lucas).

We found this species extremely abundant in Start Bay in 1898,† while later in the same year a single specimen was recorded from the Irish Sea by Mr. Walker.‡ Our present record deals with material collected nine years ago, so that it is improbable that the appearance of the species in British collections is due to a recent extension of range. Mr. Walker speaks of the difficulty of distinguishing this form from *Leptomysis apiops*, G. O. Sars, but the latter has a smooth skin, while that of *D. longicornis* is most conspicuously hispid.

The synonymy of the species is chiefly the result of the misplaced industry of Czerniavsky, who, mistrusting the identity of Sars' species with the imperfectly defined *M. longicornis* of Milne-Edwards, changed the specific name of the former to *A. platydens*, while nevertheless including Milne-Edwards' species in the genus of which Sars' species was made the type. At the same time a new species, *A. spinosissima*, was erected for the reception of specimens, also from the Bay of Naples, which do not appear to us to differ from the type in any essential feature. Since no note is made of the character of the skin in Czerniavsky's dichotomic table (*op. cit.*, p. 137), it may be presumed that *A. spinosissima* is as hispid as *D. longicornis*. In the same table the dimensions of the two species have been transposed, *A. spinosissima* being in fact founded on specimens considerably smaller than those described by Sars. To this difference in size may, perhaps, be ascribed such discrepancies (other than those of slight abnormality of the telson, *cf.* Pl. xxxi., fig. 19) as Czerniavsky was able to detect.

#### Sub-family.—MYSIDELLINÆ.

#### Genus *Mysidella*, G. O. Sars.

*Body* short and robust. *Eyes* well developed or rudimentary. *Antennal scale* small, lanceolate, setose on both margins. *Peduncle of antennule* in male with only a very small hirsute lobe. *Labrum* obtuse in front, produced behind into two unequal lobes. *Mandible* large, the incisive extremity very much dilate and flattened, in the form of a blade without a trace of teeth or spines. *First maxilla*, its processes strongly incurved; the outer large, compressed, sub-spathulate, with obliquely

† *Journ. M. B. A.*, N. S., v., 1898, p. 344.

‡ *Ann. Rep. Port Erin Biol. Stat.*, 1898, p. 15.

truncate edge set with numerous unguiform spines; the inner in the form of a setose tubercle. *Second maxilla* small and feeble. *First maxilliped* strong; basal joint without an incisive lamina, second joint very short, third rather swollen; penultimate without setæ, but strongly spined at the external apex; last joint very small and armed with a long, narrow apical spine. *Legs* small and feeble, sparsely setose; tarsus with few articulations, nail inconspicuous. *Incubatory pouch* of female of three lobes on each side, the anterior pair rudimentary. *Genital appendages* of male very long, anteriorly directed, without setæ. *Pleopods* rudimentary, simple, alike in both sexes. *Telson* short, anterior part of lateral margin naked, posterior part closely spined, a small apical cleft. *Uropods* short, subequal; otocyst well developed. (Abbreviated from G. O. Sars.)

### ***Mysidella typica*, G. O. Sars.**

(Pl. xvi., figs. 6, 7.)

*Mysidella typica*, G. O. Sars, Carcinolog. Bidrag til Norges Fauna, I. Monogr. Mysider, Hefte III., 1879, p. 86, pls. xxxv., xxxvi.

*Body* rather abbreviate; cephalo-thorax short, sub-gibbous; abdomen much more slender, cylindrical, slightly tapering, last segment short; last two segments of cephalo-thorax exposed dorsally. *Rostrum* distinctly angular. *Eyes* well developed, but not large, rather remote from each other, bright fulvous. *Peduncle of antennule* scarcely one-fourth as long as the cephalo-thorax, its basal joint short, nearly as wide as long. *Antennal scale* three times as long as wide, reaching by scarcely a third of its length beyond peduncle of antennule, outer margin nearly straight, inner distinctly arcuate, apex bluntly acuminate. *First maxilliped* with the penultimate larger than the preceding joint, and armed with three teeth. *Legs*, first hardly longer than second maxillipeds; tarsus shorter than preceding joint, 2-articulate; nail slender, setiform; second to fifth legs sub-equal in length; tarsus longer than preceding joint, 3-articulate; posterior leg much longer than the rest, very narrow; tarsus elongate, 3-articulate. *Telson* hardly one-fourth as long as abdomen, about twice as long as wide, linguiform, tapering distinctly towards the apex; anterior half of lateral margin naked, posterior half with about eighteen closely set spines of gradually increasing length, apex obtusely rounded, with a short, narrow rectilinear cleft; each side of cleft with (about) two to four minute spines. *Inner uropod* a little longer than telson, about seven-eighths as long as the outer, its inner margin spined throughout (from the level of the centre of the otocyst). *Colour*, body pellucid with a little red pigment here and there. *Length*



of adult female hardly exceeding 8 mm. (Abbreviated with slight alteration from G. O. Sars.)

*Survey.*—Station 115, off the Skelligs, 62 to 52 fathoms, mud and sand. August 20th, 1890 (in muslin bag attached to trawl).

*No Previous British Record.*

*Distribution.*—Western Norway, 50 to 150 fathoms (G. O. Sars).

Our material consists of two specimens, both of adult size. Though considerably damaged, their determination is not difficult. Mr. Green has depicted a first maxilliped of one specimen, and the telson and inner uropod of the other (figs. 6 and 7). The maxilliped has lost most of its setæ. It will be noticed that the cleft of the telson has only two spines on one side and three on the other. Sars describes and figures four on each side, but the variation is unimportant.

[NOTES ADDED IN PRESS.]

NOTES ADDED IN PRESS.

**Euphausia pellucida**, Dana. Taken in the serial tow-nets of Station 2 of Mr. George Murray's "Oceana" Expedition,  $52^{\circ} 45' N.$ ,  $12^{\circ} 27' W.$ , 453 fathoms.

An oceanic species of very wide distribution, *not previously recorded from within the British area.*

---

**Stylocheiron** sp. Taken in company with the last. *No member of this genus has hitherto been recorded from within the British area.*

---

**Nyctiphanes Couchii** (Bell). Evidence presented by a small example (about 6 mm. long), taken off Plymouth, points to the absence of exopods on the fifth and sixth pairs of legs in the female of this species, as in *N. australis*. The imperfect condition of the remaining female specimens in our possession does not permit of the complete establishment of this point. In the female *N. norvegica* exopods are present on all the legs (except the last pair, which are quite rudimentary throughout the genus), as in the males of all three species.

---

**Macropsis Slabberi** (Van Beneden). A single specimen taken in a surface tow-net at night, Inisbofin Harbour, 5th August, 1899.

*No Previous Irish Record.*

*Distribution.*—Firth of Forth; Falmouth (A. M. N.\*): Whitsand Bay; Tamar Estuary.

Sweden; Denmark; Holland; Belgium; Mouth of the Seine; Mediterranean; Black Sea (A. M. N.\*): Heligoland; German North Sea Coast (Ehrenbaum); Channel Islands (Walker and Hornell).

---

**Erythrops serrata**, G. O. Sars. Specimens from the Clyde, communicated by Mr. W. T. Calman, agree in particulars of serrulation of the inner uropod with the Irish examples.

## LIST SHOWING THE COMPARATIVE REPRESENTATION OF DIFFERENT SPECIES IN THE SURVEY HAULS.

## Station 115, 62 to 52 fathoms:—

<i>Erythroptis serrata</i> , ..	very numerous.
<i>Mysidopsis didelphys</i> , ..	18.
<i>Mysidella typica</i> , ..	2.
<i>Mysidopsis hibernica</i> , ..	1.
<i>Parerythroptis obesa</i> , ..	1.
<i>Schistomysis spiritus</i> , ..	1.
<i>Nyctiphanes norvegica</i> , ..	1.

## Station 118, 32 to 28 fathoms:—

<i>Schistomysis ornata</i> , ..	many.
<i>Leptomysis gracilis</i> , ..	rather less numerous.
<i>Mysidopsis angusta</i> , ..	30 ca.
<i>Leptomysis lingvura</i> , ..	15 ca.
<i>Dasymysis longicornis</i> , ..	4.
<i>Anchialus agilis</i> , ..	2.
<i>Mysidopsis gibbosa</i> , ..	1.

## Station 121 a, 41 fathoms:—

<i>Anchialus agilis</i> , ..	6.
<i>Leptomysis gracilis</i> , ..	1.
<i>Schistomysis ornata</i> , ..	1.

## Station 125, 115 fathoms:—

<i>Mysidopsis didelphys</i> , ..	1.
<i>Erythroptis serrata</i> , ..	1.

## Station 130, 24 fathoms:—

<i>Leptomysis gracilis</i> , ..	14.
<i>Thysanoessa neglecta</i> , ..	12 or 13.
<i>Schistomysis ornata</i> , ..	12 ca.

## Station 143, 46 to 44 fathoms:—

<i>Schistomysis ornata</i> , ..	4.
<i>Erythroptis serrata</i> , ..	2.
<i>Mysidopsis angusta</i> , ..	2.

## Station 144, surface over 45 fathoms, ca:—

<i>Thysanoessa neglecta</i> , ..	many.
----------------------------------	-------

## Station 145, 5 fathoms or less:—

<i>Siriella armata</i> , ..	9.
<i>Gastrosaccus sanctus</i> , ..	5.
<i>Leptomysis mediterranea</i> , ..	1.

## Station 148, 38 fathoms:—

<i>Schistomysis ornata</i> , ..	6.
---------------------------------	----

## Station 223, 9 to 4 fathoms:—

<i>Schistomysis spiritus</i> , ..	many.
<i>Gastrosaccus spinifer</i> , ..	2.

EXPLANATION OF PLATE XVI.\*

Figure

1. Male of *Nyctiphanes Couchii*, 12 mm., from Valentia Harbour.
2. Telson and inner uropod of *Parerythrops obesa* from S.W. Ireland, dorsal aspect.
3. The same, ventral aspect.
4. Telson and inner uropod of *Mysidopsis hibernica* from S.W. Ireland, dorsal aspect.
5. Inner uropod of same, ventral aspect.
6. Telson and inner uropod of *Mysidella typica* from S.W. Ireland, dorsal aspect.
7. First maxilliped of same.

[In figs. 4 to 6 the setæ have been omitted.]

\* Owing to a misunderstanding, for which the editor is in no way responsible, the plate was allowed to go to press before certain necessary corrections had been made. The exopodite of the sixth leg (the penultimate thoracic appendage, the last being rudimentary) is not shown; and the structure of the remaining legs is obscure, each exopodite appearing to consist of a single ciliated joint directly articulated to the rest of the limb. This erroneous impression is conveyed by the complete masking of the basal portion of the endopodites by the proximal joints of the exopodites. The gills are shown in accurate detail in fig. I., p. 226.

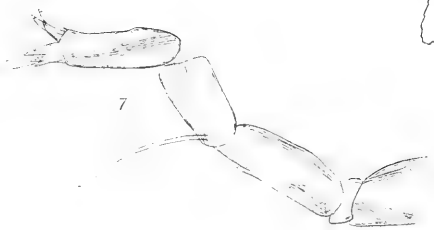
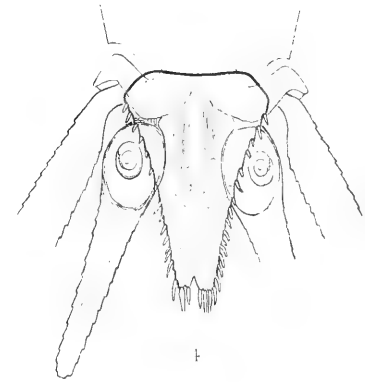
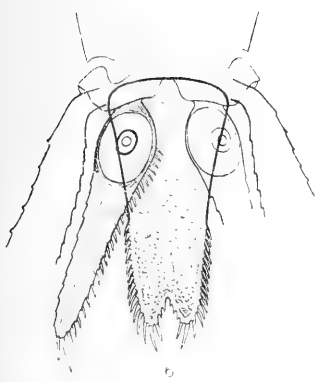
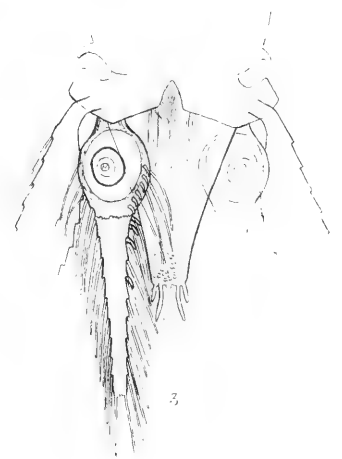
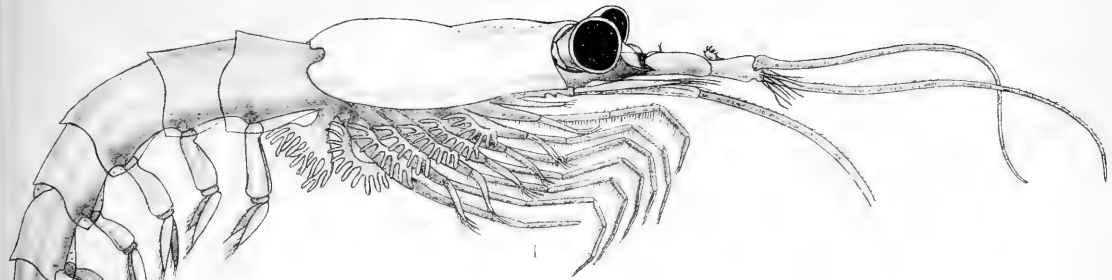





## TRANSACTIONS (SERIES II.).

---

VOL. I.—Parts 1-25.—November, 1877, to September, 1883.

VOL. II.—Parts 1-2.—August, 1879, to April, 1882.

VOL. III.—Parts 1-14.—September, 1883, to November, 1887.

VOL. IV.—Parts 1-14.—April, 1888, to November, 1892.

VOL. V.—Parts 1-13.—May, 1893, to July, 1896.

VOL. VI.—Parts 1-16.—February, 1896, to August, 1898.

---

### VOLUME VII.

#### PART

1. A Determination of the Wave-lengths of the Principal Lines in the Spectrum of Gallium, showing their Identity with Two Lines in the Solar Spectrum. By W. N. HARTLEY, F.R.S., and HUGH RAMAGE, A.R.C.S.C.I. Plate I. (August, 1898.) 1s.
2. Radiating Phenomena in a Strong Magnetic Field. Part II.—Magnetic Perturbations of the Spectral Lines. By THOMAS PRESTON, M.A., D.SC., F.R.S. (June, 1899.) 1s.
3. An Estimate of the Geological Age of the Earth. By J. JOLY, M.A., B.A.I., D.SC., F.R.S., F.G.S., M.R.I.A., Honorary Secretary of the Royal Dublin Society; Professor of Geology and Mineralogy in the University of Dublin. (November, 1899.) 1s. 6d.
4. On the Electrical Conductivity and Magnetic Permeability of various Alloys of Iron. By W. F. BARRETT, F.R.S.; W. BROWN, B.Sc.; R. A. HADFIELD, M.Inst.C.E. Plates II. to IX. (January, 1900.) 4s.
5. On some Novel Thermo-Electric Phenomena. By W. F. BARRETT, F.R.S., Professor of Experimental Physics in the Royal College of Science for Ireland. Plate IXA. (January, 1900.) 1s.
6. Jamaican Actiniaria. Part II.—Stichodactylinae and Zoanthæ. By J. E. DUERDEN, Assoc. R. C. Sc. (Lond.), Curator of the Museum of the Institute of Jamaica. Plates X. to XV. (January, 1900.) 3s.
7. Survey of Fishing Grounds, West Coast of Ireland, 1890-1891. X.—Report on the Crustacea Schizopoda of Ireland. By ERNEST W. L. HOLT, and W. I. BEAUMONT, B.A., Cantab. Plate XVI. (April, 1900.) 1s. 6d.



[SEPTEMBER, 1900.]

THE  
SCIENTIFIC TRANSACTIONS  
OF THE  
ROYAL DUBLIN SOCIETY.

VOLUME VII.—(SERIES II.)

---

VIII.

THE ACTION OF HEAT ON THE ABSORPTION SPECTRA AND CHEMICAL  
CONSTITUTION OF SALINE SOLUTIONS.

By W. N. HARTLEY, F.R.S., Royal College of Science, Dublin.

(PLATES XVII. to XXII.)

---

DUBLIN:  
PUBLISHED BY THE ROYAL DUBLIN SOCIETY.  
WILLIAMS AND NORGATE,  
14, HENRIETTA STREET, COVENT GARDEN, LONDON;  
20, SOUTH FREDERICK STREET, EDINBURGH; AND 7, BROAD STREET, OXFORD.  
PRINTED AT THE UNIVERSITY PRESS, BY PONSONBY AND WELDRICK.

1900.

---

*Price Three Shillings and Sixpence.*



## INDEX SLIP.

---

HARTLEY, W. N.—The Action of Heat on the Absorption Spectra and Chemical Constitution of Saline Solutions.  
Roy. Dublin Soc. Trans., 2, vol. 7, 1900, pp. 253-312.

Absorption Spectra and Chemical Constitution of Saline Solutions, Action of Heat on the.  
Hartley, W. N.  
Roy. Dublin Soc. Trans., 2, vol. 7, 1900, pp. 253-312.

Heat, Action of, on the Absorption Spectra and Chemical Constitution of Saline Solutions.  
Hartley, W. N.  
Roy. Dublin Soc. Trans., 2, vol. 7, 1900, pp. 253-312.

Saline Solutions, Action of Heat on the Absorption Spectra and Chemical Constitution of.  
Hartley, W. N.  
Roy. Dublin Soc. Trans., 2, vol. 7, 1900, pp. 253-312.

INDEX 211P.

HARTLEY, W. N.—The Action of Heat on the Absorption Spectra and Chemical Constitution of Saline Solutions. *Trans. Roy. Dublin Soc.*, vol. 7, 1906, pp. 323-317.

Absorption Spectra and Chemical Constitution of Saline Solutions. Action of Heat on the. *Hartley, W. N.*  
*Trans. Roy. Dublin Soc.*, vol. 7, 1906, pp. 323-317.

Heat, Action of on the Absorption Spectra and Chemical Constitution of Saline Solutions. *Hartley, W. N.*  
*Trans. Roy. Dublin Soc.*, vol. 7, 1906, pp. 323-317.

Saline Solutions, Action of Heat on the Absorption Spectra and Chemical Constitution of. *Hartley, W. N.*  
*Trans. Roy. Dublin Soc.*, vol. 7, 1906, pp. 323-317.

[SEPTEMBER, 1900.]

THE  
SCIENTIFIC TRANSACTIONS  
OF THE  
ROYAL DUBLIN SOCIETY.

VOLUME VII.—(SERIES II.)

---

VIII.

THE ACTION OF HEAT ON THE ABSORPTION SPECTRA AND CHEMICAL  
CONSTITUTION OF SALINE SOLUTIONS.

By W. N. HARTLEY, F.R.S., Royal College of Science, Dublin.

(PLATES XVII. TO XXII.)

---

DUBLIN:  
PUBLISHED BY THE ROYAL DUBLIN SOCIETY.  
WILLIAMS AND NORGATE,  
14, HENRIETTA STREET, COVENT GARDEN, LONDON;  
20, SOUTH FREDERICK STREET, EDINBURGH; AND 7, BROAD STREET, OXFORD.  
PRINTED AT THE UNIVERSITY PRESS, BY PONSONBY AND WELDRICK.

1900.



VIII.

THE ACTION OF HEAT ON THE ABSORPTION SPECTRA AND CHEMICAL CONSTITUTION OF SALINE SOLUTIONS. BY W. N. HARTLEY, F. R. S., Royal College of Science, Dublin. (Plates XVII. to XXII.)

[Read FEBRUARY 21, 1900.]

CONTENTS.

	PAGE		PAGE
Introduction, . . . . .	253	Photographed Spectra of Didymium Sulphate, Praseodym Ammonium Nitrate, and Neodym-ammonium Nitrate, . . . . .	290
Early experiments of Schenbein, von Babo, and Schiff, on the constitution of Saline Solutions, . . . . .	254	Recent experiments of Muthmann and Stützel on Neodym and Praseodym Salts, and of Ostwald on Permanganates discussed, . . . . .	292
Researches of Gladstone, Bunsen, Melde, Burger, H. W. Vogel, Landauer, Morton and Bolton, and Russell, on the Absorption Spectra of Solutions, . . . . .	254	Deductions and Conclusions, . . . . .	293
Method of Experimenting, . . . . .	256	The Spectrum of Potassium Permanganate described and measured, . . . . .	294
<b>PART I.</b>		<b>PART V.</b>	
The Absorption Spectra of Nickel and Copper Salts described and measured, . . . . .	258	<i>The Molecular Constitution and Dissociation Phenomena of Saline Solutions.</i>	
Spectra of Anhydrous Substances and Salts not dehydrated at 100° C., . . . . .	259	The action of different Solvents, . . . . .	296
The molecular weight of Anhydrous Haloid Salts determined by Beckmann's method, . . . . .	261	The effect of heat on the Absorption Spectra. Conclusion I., . . . . .	297
The Composition of the Hydrates of Nickel Bromide and Iodide determined, . . . . .	262	Reactions of Salts in solution at different temperatures, . . . . .	298
<b>PART II.</b>		Conclusion II., . . . . .	298
Spectra of Cobalt Salts described, . . . . .	267	Crystallized Hydrates generally dissolve in cold water without dissociation of the Molecule. Conclusion III., . . . . .	298
Method of photographing the Absorption Spectra in the region of Coloured Rays, . . . . .	268	Dehydration of a Crystalline Hydrate in an Aqueous Solution by Alcohol and the recrystallization of the original Salt on Evaporation, . . . . .	300
Varying limits of accuracy in the measurements of Absorption Spectra, . . . . .	269	No evidence of Alcoholates being formed. Experiments of Potilitzin on Cobalt Chloride, . . . . .	301
Cobalt Salts form Oxychlorides, Oxybromides, and Oxyiodides, . . . . .	278	Tabulated statements of the changes in colour of Aqueous Solutions of Salts, &c., . . . . .	302
Evidence that the Haloid Salts are not Hydrolysed, . . . . .	278	Evidence of several Hydrates of the one Salt being simultaneously present in the same Solution, . . . . .	303
<b>PART III.</b>		Remarkable behaviour of Cupric Bromide, . . . . .	303
The action of heat on the Absorption Spectra of Chromium Salts. Measurements of Spectra, . . . . .	279	Conclusions IV. and V., . . . . .	304
Change in the Chemical Constitution of Chromium Salts when their solutions are heated, . . . . .	281	The colour relations of Solid Salts to those of the same substances in Solution, . . . . .	304
The experiments of Schrotter, Kruger, and Löswel discussed, . . . . .	283	The most stable Hydrates in concentrated Solutions of Cupric Chloride and Bromide, and Nickel Bromide and Iodide, . . . . .	306
Thermo-chemical researches of Recoura on the Constitution of Chromium Salts, . . . . .	286	Evidence of the Compounds formed in some Aqueous Solutions, . . . . .	306
Chromoxalates and Chromo-sulphates, their constitution, . . . . .	287	Reference to Rüdorff's, De Coppet's, and Thomsen's experiments on the formation of Liquid Hydrated Salts, . . . . .	307
Lapraik's investigation of the Spectra of Chromium Salts, and evidence of the existence of two Chromoxalic Acids, . . . . .	287	Conclusion VI., . . . . .	307
<b>PART IV.</b>		Conclusion VII., and references to Ostwald's and Ewan's Observations on the Absorption Spectra of very Dilute Solutions, . . . . .	307
Spectra of Salts of Uranium, Didymium, and Permanganates described, . . . . .	287	Summary and General Conclusions, . . . . .	308 to 312
Measurements of Spectra of various Didymium Salts, . . . . .	288		
Reference to the investigation of Bunsen and of H. Becquerel, . . . . .	289		

Introduction.

IN the years 1874-75 the Secretary of the Royal Society (now Sir George Gabriel Stokes) did me the honour of presenting for publication two papers with the

above title, one was a preliminary notice,\* the other a detailed account of the spectra of a number of metallic salts, together with the conclusions arrived at as to their chemical constitution when dissolved in water.

The bare conclusions were published in the Proceedings as an abstract of the Paper.†

The greater part of the memoir was withheld for a time merely for the purpose of reducing arbitrary measurements of the spectra to wave-lengths, and of inserting Fraunhofer's lines in the diagrams. It happened that in consequence of an illness, and other circumstances which intervened, the experimental details here recorded were put aside and overlooked, but the results obtained twenty-four years ago have quite recently been confirmed in several particulars.

The following passage appears in the original communication and is still of some interest:—

“When a substance is dissolved in water, it is at present an unsolved problem what the exact constitution of the resulting liquid really is. If the salt be anhydrous like common salt, it may possibly combine with a portion of the water to form a more complex molecule, which in its turn is dissolved, or the whole of the water may combine with the salt to form a still more complex liquid molecule. In the case of this latter alternative, such solutions are chemical compounds. On the other hand, if the substance is one in which water forms an integral part of the molecule of the salt, it may be dissolved without the molecule undergoing any chemical change, or the salt may be separated from its water of crystallization, and be dissolved as an anhydrous or partially dehydrated substance.”

There are many observed phenomena connecting the absorption spectra of saline solutions with the molecular constitution of the dissolved salts which have not yet been published, and at the present time are perhaps of greater interest than at any earlier date.

Schœnbein,‡ von Babo, Schiff,§ and others have observed the darkening of both solids and solutions by the action of heat.|| Gladstone's¶ experiments show rather that haloid salts are not decomposed by solution in water, as was formerly supposed, and furthermore that cupric chloride in solution, on addition of further quantities of water, forms differently hydrated compounds.\*\*

In 1857, Dr. Gladstone published his well-known Paper “On the use of the Prism in Qualitative Analysis.”†† The effect of heat on coloured liquids was also

\* Proc. Roy. Soc., vol. xxii., p. 241. † Proc. Roy. Soc., vol. xxiii., p. 372.

‡ Jahresbericht, 1852, p. 301; 1853, p. 312; 1857, p. 72; 1859, p. 53.

§ Ann. Ch. Phar., cx., p. 203.

|| Gmelin's “Handbook of Chemistry,” English edition, vol. 5, p. 337.

¶ Jour. Chem. Soc., vol. 7, p. 211.

\*\* See also Jour. Chem. Soc., vol. 13, p. 206, 1875.

†† Jour. Chem. Soc., vol. x., p. 79; Phil. Mag., vol. xix.; Proc. Roy. Soc., vol. ix., pp. 66-74, 1859; Jour. Chem. Soc., vol. xi., pp. 36-40, 1859.



studied by Gladstone. E. J. Houston\* has dealt chiefly with the spectrum observations of substances unaffected in chemical composition by change of temperature, as ferric oxide and cuprous iodide, &c. He concluded that heat caused the colour of the substance to pass from one of a greater to one of a less number of vibrations per unit of time. Similar phenomena were studied by Ackroyd, and termed metachromism or colour change.†

A most important paper by Bunsen was published, in 1866, on the absorption spectra of salts of didymium.‡ He examined the salts both in the crystalline state and in solution, and found that they presented several differences. The width of the absorption bands varies with the thickness and the quantity of salt contained in the absorbing medium. Solutions of the chloride, sulphate, and acetate, each containing the same quantity of didymium yielded different spectra, the bands being shifted towards the red with increase in the molecular weight of the salt. Drawings to scale are given, but it is to be regretted that the measurements were not reduced to wave-lengths. It may be mentioned that an instrument of great dispersion was found necessary to establish the fact that the bands were shifted, and that each of the bands near D, E, and F showed this displacement.

The interpretation of this phenomenon, according to the views which I have expressed elsewhere, is, first, that the salts are not hydrolysed into an acid and a base; secondly, that chloride, sulphate, and acetate each exists as an integral molecule in the solution; and thirdly, that as the molecular mass of the didymium salt is increased, its rate of vibration is proportionally retarded.§

Melde investigated the spectra of mixed coloured solutions, and studied also the action of heat on absorption bands.||

H. Burger believed that the changes observed by Melde were not merely physical, but partly chemical, taking into account the work of Magnus and H. W. Vogel.¶

Landauer showed that saffranin and its salts formed differently coloured hydrates in solution, and could undergo dehydration to a greater or less extent by the addition of more or less strong sulphuric acid to the aqueous solution.\*\*

W. J. Russell made a very careful examination of the salts of cobalt,†† in the fused state, and when mixed with other fused salts, in various indifferent solvents, in alcohol and acids.

\* Chem. News, vol. xxiv., p. 177.

† Chem. News, vol. 34, p. 75, 1876; and Phil. Mag., vol. 2, p. 423, 1876.

‡ "Ueber die Erscheinungen beim Absorptions-Spectrum des Didyms." Pogg. Ann., vol. 128, p. 100.

§ Trans. Chem. Soc. vol. xxxix., p. 165, 1881.

|| Pogg. Ann., vol. cxxiv., p. 91, and vol. cxxvi., p. 264.

¶ Spectroscopische Untersuchungen über die Constitution von Lösungen. H. Burger. Ber., vol. ii., p. 6, 1876-78, 1878; Praktische Spectralanalyse irdischer Stoffe. H. W. Vogel, pp. 123 and 212.

\*\* Zur Kenntniss der Absorptions-Spectra. Ber., vol. ii., p. 1772.

†† Proc. Roy. Soc., vol. 31, pp. 51-54; and 32, pp. 258-272.

He observed that the haloid salts of cobalt differed in respect to the position of the absorption bands inasmuch as the bromide exhibited a band nearer to the red than the chloride, while that of the iodide was moved still further down. The effect of heat and that of substances capable of combining with water on aqueous solutions of cobalt chloride are identical, as both tend to form the banded spectrum of the anhydrous chloride when viewed in solution.

#### *Method of Experimenting.*

In 1873-74, I examined a number of salts both in the solid state and in solution at different temperatures, but generally at 20° and 100° C. Wedge-shaped cells of glass were used to hold the liquids, and these were heated in an air-bath provided with two sides of glass, so that light might be passed through the cells and projected on to the slit of a spectroscope provided with a single flint-glass prism. The measuring arrangement was a divided circle over which the telescope moved. In measuring dark bands, which gradually merged into bright spaces, the cross-wires in the eye-piece were placed in this position X, and the telescope was moved so that they were only just obscured by the dark shading to the extent of one-half the field of view. The accuracy attainable with consecutive readings was in many cases such as to limit the error to about one minute of arc between 35° and 39° 39', or about  $\frac{1}{2 \times \frac{1}{8}}$ th of the spectrum from  $\lambda$  768 below A, to  $\lambda$  410 or *h*.

The wedge-cells were cut out of thick pieces of glass in the following manner. A block of glass  $\frac{3}{4}$  in. by  $\frac{3}{4}$  in. by 3 in. had a slice off one of its solid angles ground down to 45° for the space of an inch in the centre of the block, and the surface of this was polished. By placing a piece of plate-glass against one of its sides, and fixing it by a metal clamp, a wedge-shaped vessel or hollow prism of 45° was formed, having a depth of  $\frac{3}{4}$  in., the thickest part of the hollow being also  $\frac{3}{4}$  in. The refraction of the liquid prism was thus compensated by the solid prism of glass. Some thinner wedges also were made for darkly coloured liquids. Their dimensions were  $\frac{5}{16}$ ths in. by  $\frac{3}{4}$  in. by 3 in., the thickest part being able to contain a layer of liquid  $\frac{3}{16}$ ths of an inch in thickness.

The air-bath was provided with a thermometer and a Geissler gas-regulator or thermostat, which were placed close to the cell containing the solution under examination. An efficient source of light when the sun was not available consisted of an argand burner of the ordinary construction for gas, into the hollow centre of which a narrow tube of  $\frac{1}{16}$ th of an inch in diameter was introduced. The end of this tube was closed, but the periphery was pierced with small holes. This tube conveyed oxygen into the flame, and yielded a very brilliant light when needed. Most of the salts examined were prepared by myself; some were quite new, and a complete examination of their properties was necessary.

In order to be able to judge from absorption spectra of the condition of a salt when dissolved in water, and of any chemical change taking place when the solution is heated, it is necessary to know the answers to the following questions :—

1st. How far do the absorption spectra of aqueous solutions of various salts of the same metal differ from one another, and how are salts affected by different solvents ?

2nd. What change in the absorption of light is caused by heating coloured solutions to 100° C. ?

3rd. Is there any remarkable difference between the spectra of hot and cold solutions which corresponds to the difference between the crystallized salts at the ordinary temperature and when dehydrated at 100° C. ?

## PART I.

## The Absorption Spectra described.

The spectra of metallic solutions are principally of three kinds:—

- (1) *Continuous spectra, or bands of rays uninterruptedly transmitted.*
- (2) *Groups of rays of different refrangibilities separated by one or more broad absorption bands.*
- (3) *Spectra interrupted by sharp black bands or lines.*

Substances showing such spectra as the second—for instance, chromium salts—are markedly dichroic. I propose to take the simplest spectra first.

*The Spectra of hot and cold Solutions of Copper and Nickel Salts.*—A continuous absorption in the red, or in both red and blue, characterises these substances, and they are therefore generally green or blue in colour.

*The Spectra of Nickel Salts.* (Plate XVII.)

Aqueous Solutions.	Temperature.	Rays transmitted.	REMARKS.
NiCl <sub>2</sub> ·9H <sub>2</sub> O, . . . . .	Centigrade. 20°	λ      λ 613 to 491	{ Thick wedge-cell. Oxyhydrogen light.
” ” . . . . .	100°	598 – 507	—
NiSO <sub>4</sub> ·7H <sub>2</sub> O, . . . . .	18°	588 – 464	Bluish green.
” ” . . . . .	100°	588 – 443	Yellowish green.
Ni(NO <sub>3</sub> ) <sub>2</sub> ·6H <sub>2</sub> O, . . . . .	18°	557 – 462	Green solution.
” ” . . . . .	100°	560 – 464	—
NiSO <sub>4</sub> ·K <sub>2</sub> SO <sub>4</sub> ·6H <sub>2</sub> O, . . . . .	20°	689 – 467	—
” ” . . . . .	100°	689 – 491	—
NiSO <sub>4</sub> ·(NH <sub>4</sub> ) <sub>2</sub> SO <sub>4</sub> ·6H <sub>2</sub> O, . . . . .	16°	659 – 438	—
” ” . . . . .	100°	655 – 446	—
NiBr <sub>2</sub> ·6H <sub>2</sub> O, . . . . .	16°	635 – 602	A brown solution, almost opaque.
” ” . . . . .	100°	at 633 only.	—
NiL <sub>2</sub> ·7H <sub>2</sub> O, . . . . .	16°	643 – 466	A brown solution, almost opaque.
” ” . . . . .	100°	633 – 486	Thin wedge-cell.
Nickel acetate, . . . . .	20°	657 – 472	Thick wedge-cell.
” ” . . . . .	100°	662 – 482	—
Potassio-nickel oxalate, . . . . .	20°	689 – 425	—
” ” ” . . . . .	100°	689 – 491	—
Ammonio-nickel oxalate, . . . . .	16°	659 – 438	—
” ” ” . . . . .	100°	655 – 446	—

The Spectra of Copper Salts. (Plate XVIII.)

Aqueous Solutions.	Temperature.	Rays transmitted.	REMARKS.
CuSO <sub>4</sub> ·5H <sub>2</sub> O, . . . . .	Centigrade. At 20°	λ From 667	} All the yellow, green, and blue transmitted.
Cu(NO <sub>3</sub> ) <sub>2</sub> ·3H <sub>2</sub> O, . . . . .	100°	λ " 665	
CuCl <sub>2</sub> ·2H <sub>2</sub> O, . . . . .	20°	λ " 639	
" " " " " " " "	100°	λ " 639	} The alcoholic solution was of a yellowish green colour; that of glycerine grass-green; but on heating it became similar in colour to the solution in alcohol at 20°.
" " " " " " " "	20°	λ " 593 to 468	
" " " " " " " "	80°	λ " 585 - 478	
" " " " " " " "	100°	λ " 580 - 504	
Solution in glycerine, . . . . .	20°	λ " 659 - 449	
" " " " " " " "	100°	λ " 659 - 477	
Solution in alcohol, . . . . .	20°	λ " 659 - 449	
" " " " " " " "	75°	λ " 659 - 477	

CuCl<sub>2</sub>·2H<sub>2</sub>O.—Solutions in water were mixed with hydrochloric acid, and also with calcium chloride, and examined at 20°, 100°, and 130°. A solution mixed with ammonia was examined at 20° and 100°, but it did not change on heating.

CuBr<sub>2</sub>·5H<sub>2</sub>O.—An aqueous solution was examined at 20° and 100°.

Absorption Spectra of Substances which are not Crystalline Hydrates, or are not dehydrated at 100° C. (Plate XIX.)

Aqueous Solutions.	Temperature.	Rays transmitted.	REMARKS.
CrO <sub>3</sub> , . . . . .	Centigrade. 20°	λ 696 to 676	Thin wedge-cell.
" " " " " " " "	100°	λ 691 - 685	" " "
CrO <sub>3</sub> , . . . . .	20°	λ 696 - 558	Thick wedge-cell.
" " " " " " " "	100°	λ 691 - 565	" " "
K <sub>2</sub> Cr <sub>2</sub> O <sub>7</sub> , . . . . .	20°	λ 711 - 533	" " "
" " " " " " " "	100°	λ 696 - 537	" " "
(NH <sub>4</sub> ) <sub>2</sub> Cr <sub>2</sub> O <sub>7</sub> , . . . . .	20°	λ 685 - 555	" " "
" " " " " " " "	100°	λ 679 - 557	" " "
K <sub>2</sub> CrO <sub>4</sub> , . . . . .	20°	λ 730 - 498	" " "
" " " " " " " "	100°	λ 706 - 504	" " "
2Ce(NO <sub>3</sub> ) <sub>4</sub> ·4KNO <sub>3</sub> ·3H <sub>2</sub> O, . . . . .	34°	λ 676 - 503	{ Faint band at λ 582, probably due to didymium.
" " " " " " " "	100°	λ 696 - 517	—
Pd(NH <sub>4</sub> ) <sub>2</sub> Cl <sub>4</sub> , " " " " " " " "	16°	λ 730 - 565	Thin wedge-cell.
" " " " " " " "	100°	λ 730 - 569	" " "
PdK <sub>2</sub> Cl <sub>4</sub> , " " " " " " " "	20°	λ 730 - 560	" " "
" " " " " " " "	100°	λ 724 - 565	A dull spectrum.
AuCl <sub>3</sub> , . . . . .	16°	λ 649 - 470	—
" " " " " " " "	100°	λ 643 - 477	—
K <sub>2</sub> S <sub>8</sub> , . . . . .	20°	λ 730 - 519	Thin wedge-cell.
" " " " " " " "	100°	λ 730 - 545	" " "
Prussian blue dissolved in } oxalic acid. } A mixture of ferric chloride and } potassium sulphocyanate. }	20° 100° 16° 100°	λ 533 - 451 540 - 451 724 - 604 667 - 568	Dilute solution. Thin wedge-cell. Intensely dark solution. It was therefore diluted.

*Ceric Potassium Nitrate.*—At  $\lambda$  582 there appeared a faint sharp shade, and this doubtless proceeded from a trace of didymium, as it coincides with the centre of the strongest and blackest lines of absorption characteristic of didymium salts. Gladstone has shown that 0.05 per cent. of didymium, in a solution half an inch thick, may be detected by it.\*

*Gold Chloride.*—The darkening in this case is possibly in part due to concentration of the solution by evaporation.

*Potassium Pentasulphide.*—This was made by boiling potash with an excess of sulphur. The solution was kept in a stoppered bottle for two months unopened. It had the characteristic strong yellow colour.

*A mixture of Ferric Chloride and Potassium Sulphocyanate.*—This solution was intensely dark; it was therefore diluted until sufficiently transparent.

None but the red rays were transmitted by the cold solution. The experiments of Schiff† afford strong evidence that, on heating the solution of the mixed salts, the ferric sulphocyanate becomes converted into ferric chloride with the simultaneous formation of potassium sulphocyanate again. This is confirmed by an examination of its spectrum at 20° and 100° C. (Plate XIX.).

From an examination of these substances it appears evident—

1st. That in compounds in which water forms no integral part of the molecule, the action of heat on the absorption spectrum causes little or no alteration. Any measurable change amounts to a slight darkening of the solution by increasing the absorption of the less or more refrangible rays (see Plate XIX.).

2nd. Concentrated solutions of salts, in which water forms an integral part of the molecule, show a very marked change in their spectra when heated to 100°, inasmuch as there is a great increase in the absorption of light resembling that caused by dehydration of the solid substance at that temperature. This is more particularly to be remarked in the haloid compounds, and such substances as are more readily soluble than the sulphates and nitrates (Plates XVII. and XVIII.). It may be seen in the solutions of cupric chloride, in glycerine and hydro-chloric acid, in alcohol, and when mixed with calcium chloride. The solutions were not so concentrated as the aqueous solution, and they do not, on that account, absorb quite so much of the red rays. The glycerine solution behaves, upon heating, in a similar manner, and shows the same change in its spectrum as a dilute blue solution of cupric chloride. A similar change may be noticed in nickel salts.

3rd. The hydrated bromides of nickel and copper exhibit a remarkable change on heating to 100°, inasmuch as they become nearly opaque.

4th. The absorption spectra of the most soluble salts undergo the greatest amount of change upon heating.

\* Jour. Chem. Soc., vol. x., 1857.

† Ann. Ch. Phar. cx., p. 203.

*The Molecular Weight of Anhydrous Haloid Salts.*

In order to ascertain whether the remarkable difference in colour between the hydrated and the anhydrous cupric bromide was due to polymerisation of the latter, a determination of its molecular weight was made by means of Beckmann's (boiling point) apparatus.

$$M = 100 \times c \frac{y}{G(t_1 - t)}$$

The solvent used was alcohol of 99.56 per cent. by weight; therefore, containing less than 0.5 per cent. water. The constant  $c$  for alcohol is 11.5. The jacket, as well as the inner tube, was charged with this alcohol. The temperature in the jacket was 77.5 C.; the temperature in the tube, before adding any of the cupric bromide, was indicated at 1.64 on the scale of the thermometer. Four separately weighed quantities of the salt were added to the alcohol.

	Grs.	Temperature.	Rise.
1st, . . .	0.3640	Initial, . . .	1.64 —
2nd, . . .	0.4810	After 1st, . . .	1.81 0.17
3rd, . . .	0.3705	„ 2nd, . . .	2.05 0.24
4th, . . .	0.2815	„ 3rd, . . .	2.24 0.19
		„ 4th, . . .	2.39 0.15
	<hr/> 1.4970		<hr/> 0.75

$$M = \frac{100 \times 11.5 \times 1.497}{10.615 \times 0.75}$$

$$= 216.7$$

$M$  calculated = 223.52.

Calculations were made from individual quantities, and the following numbers were obtained :—

	Molecular Weight
1st, . . . . .	232.0
2nd, . . . . .	217.1
3rd, . . . . .	227.1
4th, . . . . .	203.3
	<hr/> Mean, . 219.9
Found, 219.9.	Calculated for $\text{CuBr}_2$ , 223.5.

It is quite evident that  $\text{CuBr}_2$  is the formula for cupric bromide.

This determination was made in my laboratory by Mr. J. A. Cunningham, B.A.

Schmujlow determined the molecular mass of *cuprous bromide* by dissolving it in pyridin; his numbers agreed with the formula  $\text{CuBr}$ , but not with  $\text{Cu}_2\text{Br}_2$ . Cupric chloride, in the same way, was found to be  $\text{CuCl}_2$ .\*

\* Zeitschrift für Anorganische Chemie, vol. 15, p. 18, 1897.

It is necessary here to give an account of the hydrates of nickel bromide and iodide, in order to explain the nature of the action of heat upon their absorption spectra and the constitution of their solutions.

*Preparation and Analysis. Nickel Bromide and its Hydrates.*

These salts have been but imperfectly described by Berthelot\* and by Rammelsberg.†

The analysis of the latter lead to a formula for the crystallized hydrated salt of  $\text{NiBr}_2 \cdot 3\text{H}_2\text{O}$ . I have not obtained this as a crystallized salt.

The bromide was prepared in a similar manner to that described for the preparation of haloid cobalt salts.‡

Clippings of rolled nickel were placed in a platinum dish with water and some bromine, and kept in a warm place. The green solution obtained was filtered and evaporated, and finally crystallized by allowing it to remain in a bell-jar standing over sulphuric acid.

Well-formed green crystals were obtained which, while they were very deliquescent in the air, rapidly effloresced over sulphuric acid. In this respect they resemble cupric bromide. The only way they could be dried was by crushing rapidly between folds of blotting paper. The water of crystallization was estimated in the usual way by heating in the steam-oven and weighing at repeated intervals. The nickel was estimated by precipitating a solution boiled in a platinum dish with potassium hydroxide, and igniting the precipitate in a platinum crucible at a bright red-heat over a blow-pipe. The bromine was, of course, determined gravimetrically as silver bromide.

The composition of the salt is  $\text{NiBr}_2 \cdot 6\text{H}_2\text{O}$  as the following figures show:—

*Determination of the Water.*

	I.	II.
Salt taken for analysis, . . . . .	3.5978	2.3960
Loss on heating to 100° C. till weight constant, . . . . .	1.2045	0.7957
H <sub>2</sub> O per cent., . . . . .	33.47	33.21

*Determinations of Nickel and Bromine.*

	I.	II.	III.
Weight of salt taken, . . . . .	0.4347	0.8727	1.2382
Weight of NiO precipitated, . . . . .	0.1042	0.1990	—
Ni per cent., . . . . .	18.83	17.92	—
Weight of AgBr precipitated, . . . . .	—	—	1.4143
Weight of Br, . . . . .	—	—	0.6019
Br per cent., . . . . .	—	—	48.61

\* Ann. Chim. Phys., vol. 44, p. 389. † Pogg. Annalen, vol. 55, p. 243. ‡ Jour. Chem. Soc., vol. 12, 1874.



*Composition of a second Hydrate.*

Some of the hydrated crystalline salt was placed in a watch-glass over sulphuric acid under a bell-jar, and weighed at intervals during a fortnight until the weights became practically constant. The temperature varied from about 11° C. to 16° C. during this period. The colour of this salt is yellow.

	I.	II.
Weight of salt taken, . . . . .	2·1845	5·5618
Loss of weight = H <sub>2</sub> O, . . . . .	0·4931	1·2398
H <sub>2</sub> O lost, per cent. . . . .	22·58	22·29

We arrive then at the following figures as expressing the hydration of the salt dried at the normal temperature when kept in a dry atmosphere.

	I. <i>Per cent.</i>	II. <i>Per cent.</i>
Water lost by crystals at 100° C., . . . . .	33·47	32·21
Water lost over sulphuric acid, . . . . .	22·58	22·29
Combined water in hydrate, . . . . .	10·89	10·92

This is one-third that in the original salt which, as will be seen below, is six molecules.

*Composition of the two Hydrates.*

Found.	I.	II.	Calculated for NiBr <sub>2</sub> ·6H <sub>2</sub> O.
Ni, . . . . .	18·83	17·92	17·96 <i>per cent.</i>
Br, . . . . .	—	48·61	48·97 " "
H <sub>2</sub> O at 20° C., . . . . .	33·47	33·21	33·07 " "
	99·74		100·00
Composition deduced from the Analysis.			Calculated for NiBr <sub>2</sub> ·3H <sub>2</sub> O.
Ni, . . . . .	23·18 <i>per cent.</i>		23·17 <i>per cent.</i>
Br, . . . . .	62·75 " "		62·72 " "
H <sub>2</sub> O, . . . . .	14·07 " "		14·11 " "
	100·00		100·00

*Nickel Iodide and its Hydrates.*

As in the previous case, nickel clippings to the amount of 59 grs. were placed in a platinum dish and covered with iodine and water. As the action was slow some hydriodic acid was prepared specially for the purpose and added to the contents of the dish. As soon as hydrogen was evolved, more iodine was added until all the metal had entered into solution. Excess of iodine was removed by boiling.

The solution while hot and concentrated was of a rich brown colour, but on cooling it became moss-green. The hydrated salt crystallized out in handsome

dark green hexagonal prisms on standing over sulphuric acid. These crystals, while extremely deliquescent in air, were efflorescent when standing over sulphuric acid, and rapidly became transformed into a black amorphous powder. They could not be dried by crushing between blotting paper, as it appeared to form the black anhydrous compound on coming in contact with the salt. This is probably a combination of the salt with cellulose in a manner similar to that of other chlorides.

Light was observed to have a distinct action on the substance so that the third determination of water in the salt was carried out as far as possible in darkness, and the weighings performed in a pair of ground watch-glasses. The nickel was determined as oxide, and the iodine as silver iodide.

The composition of the salt was found to be  $\text{NiI}_2 \cdot 7\text{H}_2\text{O}$ , and not that usually accepted  $\text{NiI}_2 \cdot 6\text{H}_2\text{O}$ .

*Determination of the Water.*

	I.	II.	III.
Weight of salt taken, . . . . .	2.4053	4.4870	4.3206
Loss of weight, . . . . .	0.7099	1.3227	1.1850
H <sub>2</sub> O per cent., . . . . .	29.51	29.47	27.42

Of these I. was kept over sulphuric acid, and weighed at intervals during eighteen days.

II. was heated at 100° C. in the steam-oven for ten successive periods of about three hours each, the salt cooled in a desiccator freely exposed to the light.

III. was heated at 100° C. for seven successive intervals of about three hours each; at each weighing the salts were enclosed in air-tight watch-glasses, and allowed to cool in the dark.

ANALYSES.

*Determination of the Water.*

	I.	II.	III.
Weight of salt taken, . . . . .	2.4053	4.4870	4.3206
Loss of weight, . . . . .	0.7099	1.3227	1.1850
H <sub>2</sub> O per cent., . . . . .	29.51	29.47	27.42

*Determination of Nickel and Iodine.*

	I.	II.	III.
Weight of substance, . . . . .	1.4055	1.0959	0.5669
NiO, . . . . .	0.2361	0.1866	—
Ni, . . . . .	0.1855	0.1466	—
Per cent. of Ni, . . . . .	13.20	13.38	—
Weight of AgI, . . . . .	—	—	0.6087
Weight of I, . . . . .	—	—	0.3289
Per cent. of I, . . . . .	—	—	50.02

## Composition and Formula.

Calculated for $\text{NiI}_2 \cdot 7\text{H}_2\text{O}$ .	Found. <i>Per cent.</i>	Erdmann's Analysis.*
Ni, . . . 13·38	13·29 (mean)	$\text{NiI}_2$ , . . . 72·82
I, . . . 57·86	58·02	
$\text{H}_2\text{O}$ , . . . 28·75	28·80 (mean)	$6\text{H}_2\text{O}$ , . . . 27·18
99·99	100·11	100·00

These numbers agree so very closely with the composition of a salt of the formula  $\text{NiI}_2 \cdot 7\text{H}_2\text{O}$  that I have no hesitation in assigning it that formula, though it is usually stated to be a hexahydrate.

It is completely dehydrated by standing over sulphuric acid and by heating to  $100^\circ \text{C}$ . When dried without the action of heat, it is a black amorphous powder.

These salts were prepared in my laboratory, and analysed by Mr. J. A. Cunningham, B.A., A.R.C.Sc.I.

## PART II.

## Spectra of the Second Kind.

The salts of cobalt for the most part present spectra characterised by broad absorption bands. The bands are readily weakened in intensity by diluting saturated solutions. In this respect the spectra differ widely from those of uranium salts, salts of (didymium) praseo- and neo-dymium, all of which exhibit absorption bands of the third kind and have been closely studied.

The differences arise from differences in the constitution of the spectra, and may best be exemplified by stating that not only are they greatly modified by dilution, but very slight differences in the thickness of the layer of liquid present very different spectra. While in the case of uranium compounds and didymium salts, a small difference in thickness of liquid or even great dilution does not alter the intensity or the width of the absorption bands in a proportionate degree. This is best shown by integrating the spectra, taking for ordinates the proportional thickness of liquid, and for the abscissæ the wave-lengths or oscillation-frequencies of the rays absorbed. The curves so obtained differ so very widely in the two or three classes of salts that they cannot be reproduced as suitable illustrations. There can be no doubt, when all the chemical evidence available is taken into consideration, that the spectra belong to substances quite differently constituted. H. W. Vogel† examined a number of inorganic coloured substances, such as

\* Jour. für prakt. Chem., vol. 7, p. 254.

† Ueber die Verschiedenheit der Absorptionsspectra eines und desselben Stoffs. Ber., vol. xi, p. 913, 1878.

permanganates, solid and in solution, cobalt glass, cobalt hydrate, cobalt chloride, blue, solid, the same red, solid. Cobalt chloride in water, hot and cold, cobalt chloride in alcohol, in strong and dilute solution. Uranium nitrate solid, and dissolved in alcohol and in water.

The change in the spectrum of cobalt chloride, he mentions as one of the most remarkable examples which had come under his observation. He examined also various chromium compounds. Vogel does not appear to have sought the cause of the change in the spectra of these substances. Von Babo\* tried the influence of dehydrating substances and of heat on cobalt chloride solutions. A few drops of a concentrated solution of cobalt chloride, when added to a solution of calcium or magnesium chloride boiling at  $114^{\circ}$ , became blue at ordinary temperatures; a more dilute solution boiling at  $108^{\circ}$  gave a red liquid under the usual conditions, but became blue on boiling.

A solution of common salt mixed with the cobalt compound is red until heated. With zinc chloride the same alteration did not take place, a fact explained by von Babo by the probable formation of a double salt being supposed. If we regard the matter from the point of view that dissociation takes place in these solutions, then the addition of a dehydrating substance facilitates this change in the solution, and the action of calcium and magnesium chlorides is easily understood. In the case of zinc chloride, if we presume, as von Babo suggested, that a double salt is formed, we can just as readily understand that cobalt-zinc chloride does not undergo dissociation, or that the zinc chloride of the compound does not favour it, but on the contrary prevents it, for its very action, as a dehydrating substance attracts water to the molecule and retains it, so that the hydrated zinc-cobalt chloride molecule is not dissociated, or, in other words, the metallic haloid compound is not separated from its combined water at or about  $100^{\circ}$  C., when in solution in water.

\* Jahresbericht, 1857, p. 72.

## The Examination of Cobalt Salts.

The Spectrum of Cobalt Chloride,  $\text{CoCl}_2 \cdot 6\text{H}_2\text{O}$ . Aqueous Solution.

Thin wedge-cell. Sun-light. (Plate XX. A.)

Temperature.	Description of Spectrum.	$\lambda$
At 23° C.	<b>SOLUTION RED—</b> Spectrum begins about the solar line <i>a</i> , or Rays extend to <i>Absorption Band</i> from D to beyond F, or from The spectrum extends as far as the visible rays near <i>h</i> , or to the limit of visibility.	724 679 <b>588 to 468</b> 407
At 33° C.	<b>SOLUTION PURPLISH RED—</b> Spectrum begins at <i>a</i> , or <i>Absorption Band</i> from rather below B towards C, with a further extension by reason of another band developing, to Principal <i>Absorption Band</i> from below D to between F and G, End in the blue at	724 <b>696 to 673</b> 662 <b>619 to 449</b> 407
At 43° C.	<b>SOLUTION PURPLE—</b> Spectrum begins at <i>a</i> , or <i>Absorption Band</i> from below B to a little towards C, There is an extension of the band to about C, or A further extension is seen between C and D, or to From the sharp edge of the band the diffused rays extend, too feeble to admit of the cross- wires being visible. <i>Absorption Band</i> extend- ing as in previous case to near G. Spectrum ends in the blue, or the limit of visi- bility.	724 <b>696 to 681</b> 665 619 407
At 53° C.	<b>SOLUTION PURPLE—</b> Red rays visible at or about <i>Absorption Band</i> extends from $\lambda$ 615 to near G, In the thinner part of the cell an <i>Absorption</i> <i>Band</i> between C and D is clearly visible.	615 <b>615 to 449</b>
At 73° C.	<b>SOLUTION BLUE—</b> Red rays are visible at A little light is transmitted about Great <i>Absorption Band</i> , In the thinner part of the cell two distinct absorption bands were seen.	627 589 <b>589 to 449</b>
At 93° C.	<b>SOLUTION BLUE—</b> Barely a glimmer of red rays was let through about D, and that only in the thinnest part of the cells.	

It was very difficult to make even approximately accurate observations owing to the variations in the illuminations of the field of view in the spectroscope, for, as the light diminished in quantity and intensity, the eye became accustomed to the subdued light, and the cross-wires in the eye-piece became visible in positions where previously they had been obscured. All measurements, therefore, must be regarded merely as approximations. They serve to show that the change is measurable, and to what extent it occurs under different conditions.

The variations in the spectrum of this solution were very striking, as already mentioned in a preliminary note.\* Except by reference to the drawings, no idea of them can be formed.

Occasionally an obscure band of red rays was seen to flash down the dark part of the spectrum about wave-length 720.

In the preparation of the solution of cobalt chloride 10 grs. of  $\text{CoCl}_2 \cdot 6\text{H}_2\text{O}$  were covered with 5 c.c. of water at  $16^\circ\cdot4$ , which caused the temperature to fall to  $12^\circ\cdot0$ , after which it rose. The liquid was allowed to stand until saturated with the salt, but was poured off after a lapse of 48 hours, and the crystals drained from adhering solution and weighed. 8 grs. of  $\text{CoCl}_2 \cdot 6\text{H}_2\text{O}$  were found to have dissolved in 5 c.c. of water at  $16^\circ\text{C}$ ., and the solution measured 9·2 c.c.

#### *The photographed Spectra of Cobalt Chloride Solutions.*

The general results of the examination of the cobalt chloride solutions have been confirmed, as far as practicable, by means of photography, using Cadett and Neall's *Spectrum plates*. The results vary a little from those made by the eye observations for these reasons: first, the source of illumination was sunlight; secondly, the sensitiveness of the eye is not the same as that of the photographic film; and thirdly, it may be pointed out that exactly the same thickness of liquid, or, in other words, the same part of the wedge-shaped cell, was not always examined, though, as nearly as could be judged by the eye, this was adhered to. Then again the extinction of light which rendered the cross-wires visible was judged by the eye, but no such means of measuring could be applied to the photographic method.

It was not found practicable to maintain a strictly stationary temperature, because the necessary heating apparatus could not be interposed between the condensing lens and the slit. The instrument was a spectrograph with four quartz prisms, the same that had been previously used in photographing the spectra of the Bessemer flame, and is figured and described in the *Journal of the Iron and Steel Institute*, No. II., for 1895.

It was adjusted and focussed so as to give special distinctness and sharpness to the red end of the spectrum.

\* *Proc. Roy. Soc.*, vol. xxii., p. 241.

One advantage of the photographic method is seen in the registration of the extent to which the ultra-violet rays are absorbed. Differences of exposure with the same photographic plates do not materially alter the character of the absorption bands, or the extent of the transmitted rays, but differences in the temperature of the solution do make a marked difference. Eye observations do not carry measurements further at the blue end of the spectrum than  $\lambda$  4000, but photography admits of measurements up to  $\lambda$  2872.

The small dispersion in the red compared with the violet and ultra-violet renders the value of linear measurements expressed in terms of wave-lengths much greater in the latter than in the former, as the following readings from the interpolation curve illustrate:—

Colour.	Measurements, Hundredths of an inch.	Corresponding Values in Wave-lengths.	Different Values of one-hundredth of an inch.	Colour.	Measurements, Hundredths of an inch.	Corresponding Values in Wave-lengths.	Different Values of one-hundredth of an inch.
RED.	(B 13.4	6867)		VIOLET.	(H 151.6	3968)	
	14.0	6864	70		148.0	3991	10
	15.0	6794	48		149.0	3981	9
	16.0	6746	46		150.0	3972	9
	17.0	6700	46		151.0	3963	10
YELLOW.	18.0	6654		(P 242.6	3359)		
	(D 38.0	5894)		ULTRA-VIOLET.	248.0	3335	5
	48.0	5730	30	249.0	3330	4	
	49.0	5700	30	250.0	3326	5	
	50.0	5670	31	251.0	3321	4	
	51.0	5639	32	252.0	3327	5	
	52.0	5607		253.0	3312		

The value of  $\frac{1}{1000}$ th of an inch in tenth-metres of wave-lengths is at least nine times as great in the red as in the ultra-violet, six times as great in the yellow, and twice as great in the violet. There is a limit to the accuracy with which absorption spectra may be measured; this differs with different spectra and in the same spectrum with the refrangibility of the rays measured. Absorption spectra, as a rule in the ultra-violet, are much sharper than those in the visible spectrum; it is thus easy to measure them to four figures, but in the red, yellow and green, it is

very questionable whether any value can be attached to measurements carried beyond three figures, unless perhaps in the bands of didymium salts, which are strong and well defined.

Hence the measurements of the cobalt spectra are recorded to three figures only. Absorption bands which are diffuse cannot be accurately measured with great dispersion.

### The Spectra of Cobalt Salts.

$\text{CoCl}_2 \cdot 6\text{H}_2\text{O}$ .—*A saturated Aqueous Solution at 20° C.*

Thin wedge cell, measurements taken at the middle of the cell. Photograph No. 1 :—

	λ
Spectrum begins at . . . . .	656
Rays transmitted from 656 to . . . . .	572
<i>Absorption Band</i> . . . . .	<b>572 to 474</b>
Rays transmitted from 474 to . . . . .	342
End of spectrum.	

At the upper part of the cell :—

Spectrum begins at . . . . .	649
Rays transmitted from 649 to . . . . .	612
<i>Absorption Band</i> . . . . .	<b>612 to 443</b>
Rays transmitted from 443 to . . . . .	372
End of spectrum.	

$\text{CoCl}_2 \cdot 6\text{H}_2\text{O}$ .—*Saturated Aqueous Solution at 20° C.*

Measurements taken at the middle of the cell. Photograph No. 2 :—

	λ
Complete absorption up to where spectrum begins . . . . .	653
<i>Absorption Band</i> . . . . .	<b>653 to 642</b>
<i>Absorption Band</i> , with strongest side towards λ 627, . . . . .	<b>642 to 627</b>
<i>Absorption Band</i> , with its strongest side at λ 612, . . . . .	<b>627 to 612</b>
Rays transmitted strongly to . . . . .	584
<i>Great Absorption Band</i> . . . . .	<b>580 to 450</b>
Rays transmitted from 450 to . . . . .	347

Measurements taken at the upper part of the cell :—

Rays feebly transmitted from . . . . .	627
Spectrum extends to . . . . .	620
<i>Absorption Band</i> . . . . .	<b>620 to 612</b>
Rays transmitted from λ 612 to . . . . .	602
Indications of an absorption band with its centre at . . . . .	608
<i>Absorption Band</i> . . . . .	<b>601 to 597</b>
Rays feebly transmitted to . . . . .	589
<i>Great Absorption Band</i> . . . . .	<b>589 to 436</b>
Rays transmitted from λ 436 to . . . . .	356



Measurements made at the top of the cell :—

	λ
Rays transmitted from λ 627 to . . . . .	584
<i>Absorption Band</i> . . . . .	<b>584 to 436</b>
Rays transmitted from λ 436 to . . . . .	365

Measurements taken at the thin part of the cell :—

Spectrum begins about . . . . .	700
Rays transmitted to . . . . .	552
<i>Absorption Band</i> . . . . .	<b>552 to 514</b>
Rays transmitted from 514 to . . . . .	342

A plate taken with a feeble sun spectrum above the absorption spectra of  $\text{CoCl}_2 \cdot 6\text{H}_2\text{O}$ , in aqueous solution at 20° C., gave the following measurements :—

	λ
The solar spectrum commenced at . . . . .	649
The absorption spectra commenced at . . . . .	645
Rays transmitted to . . . . .	584
<i>Great Absorption Band</i> . . . . .	<b>584 to 436</b>
Rays transmitted from λ 436 to . . . . .	365

A solution in water of  $\text{CoCl}_2 \cdot 6\text{H}_2\text{O}$ , saturated at 20° C., the spectra seen when the solution was cooling down from 60° C. gave the following measurements :—

	λ
Thinner part of cell.	
Barely perceptible transmission of rays from . . . . .	601
to . . . . .	584
<i>Great Absorption Band</i> . . . . .	<b>584 to 436</b>
Weak transmission of rays from . . . . .	466
to . . . . .	337
Thicker part of cell.	
Complete absorption of all rays to . . . . .	440
Rays transmitted from 440 to . . . . .	342

At or about 30° C. :—

Spectrum begins feebly about . . . . .	638
An <i>Absorption Band</i> discernible . . . . .	<b>634 to 627</b>
Rays transmitted from 627 to . . . . .	570
A second <i>Absorption Band</i> is observable, its strongest edge is at λ 612, but it appears to extend a little beyond this . . . . .	<b>620 to 612</b>
Rays transmitted to . . . . .	575
<i>Great Absorption Band</i> . . . . .	<b>575 to 466</b>
Rays transmitted from λ 466 to . . . . .	332

Measurements taken at the thicker part of the cell at a temperature about 30° C. :—

	λ
Rays transmitted from . . . . .	601
but very feebly to . . . . .	589
<i>Absorption Band</i> . . . . .	<b>589 to 450</b>
Rays feebly transmitted from . . . . .	450
to . . . . .	443
Strong spectrum transmitted to . . . . .	334

A series of photographs of spectra was taken from  $\text{CoCl}_2 \cdot 6\text{H}_2\text{O}$  in a saturated solution prepared at  $20^\circ \text{C}$ ., but heated to  $53^\circ \text{C}$ . and allowed to cool. Cadett and Neall's Lightning Spectrum plates were used, but they gave photographs with too little density.

The thinner part of the cell was observed and the coolest solution :—

	$\lambda$
Spectrum begins at . . . . .	656
Rays transmitted to . . . . .	560
But there are three <i>Absorption Bands</i> visible between $\lambda$ 656 and 612.	
<i>First band</i> , feeble, . . . . .	<b>656 to 642</b>
<i>Second band</i> . . . . .	<b>642 to 627</b>
<i>Third band</i> . . . . .	<b>627 to 612</b>
<i>Great Absorption Band</i> . . . . .	<b>565 to 474</b>
Rays transmitted from . . . . .	474
to beyond . . . . .	330

The first, second, and third bands are degraded on the less refrangible side, as on Plate XVIII.

The thicker layer of liquid examined :—

	$\lambda$
Rays transmitted feebly from . . . . .	627
to . . . . .	584
<i>Great Absorption Band</i> . . . . .	<b>584 to 436</b>
Rays transmitted from . . . . .	436
to beyond . . . . .	330

The thicker part of the cell at or about  $50^\circ \text{C}$ . :—

Spectrum begins feebly at . . . . .	612
Rays transmitted to . . . . .	584
<i>Great Absorption Band</i> . . . . .	<b>584 to 442</b>
Rays transmitted from . . . . .	443
to beyond . . . . .	330

The thinner layer of liquid at the lower part of the cell at  $50^\circ \text{C}$ . :—

	$\lambda$
Spectrum begins at . . . . .	623
and continues to . . . . .	584
There is evidence of an <i>Absorption Band</i> between . . . . .	<b>623 and 620</b>
And another <i>Absorption Band</i> between . . . . .	<b>620 and 612</b>
<i>Great Absorption Band</i> . . . . .	<b>584 to 465</b>
Rays transmitted from . . . . .	465
to beyond . . . . .	330

*Cobalt Chloride*,  $\text{CoCl}_2 \cdot 6\text{H}_2\text{O}$ , dissolved in absolute alcohol.—The solution looked blue, but of rather a different tint to that of the hot aqueous solution; it was also more transparent. The band of red light transmitted near C was dis-

tinctly visible. Heating did not affect the spectrum. When a saturated solution of cobalt chloride in alcohol is allowed to crystallize without the action of heat, it deposits red crystals, which are in reality the original hexahydrated salt.\*

Thin wedge-cell, sunlight, Plate XX. B, fig. 1.

*Cobalt Chloride*,  $\text{CoCl}_2 \cdot 6\text{H}_2\text{O}$ .—An aqueous solution was mixed with hydrochloric acid. Plate XX. B, fig. 2, thin wedge-cell, sunlight. The liquid was indistinguishable from the alcoholic solution to the eye, except when examined in very thin layers, when it had a greenish colour.

*Measurements taken.*

		$\lambda$
At 20° C. .	Edge of Absorption Band in the red near D, . . . . .	595
	<i>Absorption Band</i> , . . . . .	<b>562 to 503</b>
	End of visible spectrum, . . . . .	413
At 40° C. .	Red extremity of the spectrum, . . . . .	724
	The band of transmitted rays measured near C, . . . . .	699
	Edge of Absorption Band in the red, . . . . .	609
	<i>Absorption Band</i> in the green, . . . . .	<b>562 to 503</b>
	End of visible spectrum, . . . . .	416

*Cobalt Chloride*,  $\text{CoCl}_2 \cdot 6\text{H}_2\text{O}$  dissolved in glycerine.—Purplish solution, thin wedge, oxyhydrogen light, Plate XXI.

		$\lambda$
At 20° C. .	Spectrum begins, . . . . .	724
	First <i>Absorption Band</i> , . . . . .	<b>696 to 653</b>
	Second <i>Absorption Band</i> , . . . . .	<b>627 to 608</b>
	Third and principal <i>Absorption Band</i> , from near D to beyond F, not exactly measurable	
	End of spectrum visible, . . . . .	423
At 40° C. .	Spectrum begins at . . . . .	741
	Red rays only barely visible.	
	<i>Absorption Band</i> , . . . . .	<b>724 to 680</b>
	End of visible spectrum, . . . . .	413
At 100° C. .	End of visible spectrum, the red rays have almost vanished.	

*Cobalt Chloride*,  $\text{CoCl}_2 \cdot 6\text{H}_2\text{O}$ .—An aqueous saturated solution mixed with calcium chloride solution. The liquid was of the same purple hue as the solution in glycerine. Plate XX. c. Thin wedge-cell, oxygen-gas light.

The measurements were made at the following points, but the absorption bands merged into each other.

		$\lambda$
At 20° C. .	Rays transmitted from . . . . .	718
	First <i>Absorption Band</i> , . . . . .	<b>691 to 659</b>
	Second ,, ,, . . . . .	<b>627 to 604</b>
	Third ,, ,, in the green, . . . . .	<b>560 to 479</b>
	This band is not strong at 20° C.	
	End of the visible spectrum, . . . . .	400

\* For analysis, see p. 299.

At 40°, the red rays, like bands of red light, have blended, and appear to have retired to the upper part of the liquid where the layer is thinnest. The opacity of the liquid has greatly increased by rise of temperature.

At 85°, measurements were made at D,  $\lambda$  598; the rays were absorbed as far as  $\lambda$  588, and then transmitted to 423. The red rays transmitted near B were only very dimly seen.

At 100°, measurements were made at  $\lambda$  581, and at the extremity of the spectrum  $\lambda$  423. A dark band was situated about  $\lambda$  581.

*Cobalt Bromide*,  $\text{CoBr}_2 \cdot 6\text{H}_2\text{O}$ .—Aqueous solution, saturated at 20° C., of a purple colour. Thin wedge, gas-light. This solution absorbs moisture from the air. It was found that 6.592 grs. of the hexahydrate  $\text{CoBr}_2 \cdot 6\text{H}_2\text{O}$  dissolve in 2.129 grs. of water at 16° C., or the salt is soluble in about one-third of its weight of water. Another experiment gave 9.6819 grs. in 2.955 grs. of water, the specific gravity of the solution being 1.6284 at 16° 3 C.

		$\lambda$
At 16° C. .	Rays transmitted from . . . . .	753
	to . . . . .	741
	<i>Absorption Band</i> , . . . . .	<b>631 to 598</b>
	Spectrum ends at . . . . .	512
At 100° C. .	Rays transmitted from . . . . .	581
	to . . . . .	545

The liquid was almost opaque ; measurements made with difficulty.

*Cobalt Bromide*,  $\text{CoBr}_2 \cdot 6\text{H}_2\text{O}$ .—Solution in alcohol, of a blue colour. Thin wedge cell, sunlight.

		$\lambda$
At 16° C. .	Rays transmitted from . . . . .	753
	to . . . . .	741
	<i>Absorption Band</i> , . . . . .	<b>631 to 598</b>
	Rays transmitted from . . . . .	598
	Spectrum ends at . . . . .	512
At 100° C. .	Rays transmitted from . . . . .	581
	to . . . . .	545

Solution almost opaque.

*Cobalt Bromide*,  $\text{CoBr}_2 \cdot \text{H}_2\text{O}$ .—Glycerine solution. Thin wedge cell. Purple colour.

		$\lambda$
At 16° C. .	Rays transmitted from . . . . .	741
	but feebly to . . . . .	724
	Rather more strongly to . . . . .	685
	Feeble <i>Absorption Band</i> , . . . . .	<b>685 to 536</b>
	Rays transmitted from . . . . .	536
	to end of Spectrum at . . . . .	473
At 100° C. .	The solution is unchanged.	

*Cobalt Bromide*,  $\text{CoBr}_2 \cdot 6\text{H}_2\text{O}$ .—Dissolved in absolute alcohol. A freshly prepared solution of a blue colour. Thin wedge.

At 16°, measurements were made at the red end,  $\lambda$  670, and the blue end  $\lambda$  425.

At 70°, measurements as before at  $\lambda$  557 and  $\lambda$  431. There was nothing remarkable in this spectrum beyond the much greater intensity of absorption at the higher temperature.

Another solution prepared in the same way as the preceding, but which had been kept some time and was of a dark greenish tint, was examined.

At 16°, measurements were made at  $\lambda$  592 and  $\lambda$  557.

At 70°, the only measurement possible was of transmitted rays at  $\lambda$  565. The dark green tinge became indigo-blue.

*Cobalt Bromide*, anhydrous,  $\text{CoBr}_2$ .—This was dissolved in absolute alcohol. Thin wedge.

At 20°, the only measurements possible were made at  $\lambda$  585 and  $\lambda$  423.

At 70°, at  $\lambda$  583.8 and  $\lambda$  433. An indigo-blue liquid unaltered by heating. It is quite evident that the blue cobalt bromide in the hydrated state,  $\text{CoBr}_2 \cdot 6\text{H}_2\text{O}$ , is contained in the alcoholic solution of the crystals, and that by heating the solution to 70° it is rendered anhydrous.

*Cobalt Sulphocyanate*,  $\text{Co}(\text{CNS})_2$ .—An aqueous solution of a purplish blue colour, very dark. Thin wedge, sunlight.

At 20°, measurements were made at  $\lambda$  724 and  $\lambda$  711. Spectrum terminates at  $\lambda$  432.

At 100°, the solution was quite opaque at this temperature.

*Cobalt Iodide*,  $\text{CoI}_2 \cdot 6\text{H}_2\text{O}$ .—A cold aqueous saturated solution of the brown hexagonal crystals. The solution is brown at 16°; below this temperature some of the substance crystallizes out, and the liquid becomes red.

The solid salt dissolved in about one-sixth of its weight of water, corresponding to four molecules of water to one of salt, or 16.227 grs. dissolved in 2.675 grs. of water at 16°, forming one of the densest saline solutions known; its specific gravity at 21° C. being 2.0817. Thin wedge, gas-light.

At 20°, a very little light, transmitted at  $\lambda$  627 and 536.

At 50°, a little light transmitted at  $\lambda$  588.

On mixing with water, a red solution is formed. Thin wedge, gas-light.

From 20° to 40°, the rays were transmitted from  $\lambda$  565 to 557.

At 100°, the rays transmitted were from  $\lambda$  563 to 560. The red solution is so diluted that heating to 100° is almost without effect upon it.

*Cobalt Iodide*. Green dihydrate,  $\text{CoI}_2 \cdot 2\text{H}_2\text{O}$ .—A cold saturated aqueous solution is of a very dark brownish green tint. Dilution with water, or absorption of moisture turns it red and of a much lighter shade.

At 20°, a very little light transmitted at  $\lambda$  588.

At 50°, the solution is quite opaque.

The best way to prepare this solution in small quantities is to let the anhydrous salt slowly deliquesce. Thin wedge, gas-light.

At 20°, very little light transmitted at  $\lambda$  585.

At 50°, the solution is quite opaque.

Dilute cobalt iodide, solution, red. This contains a hydrated compound with a greater number of molecules of water than  $\text{CoI}_2 \cdot 6\text{H}_2\text{O}$ . Thin wedge, gas-light.

At 20° to 40°, rays transmitted from  $\lambda$  685 to 557.

At 100°, from  $\lambda$  683 to 560.

Dilute solution of cobalt iodide in glycerine.

At 20°, red. Rays transmitted from  $\lambda$  561 to 545.

At 100°, unchanged.

*Cobalt Iodide*,  $\text{CoI}_2 \cdot 6\text{H}_2\text{O}$ .—Solution in alcohol. Amber brown in colour. Thin wedge, oxygen-gas light.

At 20°, brown. Rays transmitted from  $\lambda$  581 to 536

At 50°, green rays transmitted from  $\lambda$  627 to 503.

In order to ascertain whether heating an aqueous solution to 100° would yield the same compound in solution as would be produced in the dry state by heating the crystallized salt, 5 c.c. of cobalt iodide solution were evaporated down at 100°, and mixed with absolute alcohol till 5 c.c. in volume. This solution was green, and in the thin wedge, with gas-light, the only measurement made at a temperature of 20° was at  $\lambda$  503. When the cobalt iodide in the original aqueous solution was heated to 100° and examined, the transmitted rays were measured at  $\lambda$  588. Both liquids were green, but there was a tinge of a reddish hue transmitted by the aqueous solution. Allowing for the different action of the two solvents, it is quite evident that the same substance was present, but that dissociation had not been complete in the aqueous solution.

When 55 c.c. of the solution were rendered anhydrous by drying at 160°, alcohol dissolved it readily with, at first, a splendid blue tint, which afterwards, became somewhat greenish. The salt crystallized out of this solution as a bluish-green substance. This was apparently a solution of the anhydrous salt, for, on placing it in a desiccator over oil of vitriol, it returned to the anhydrous black compound,  $\text{CoI}_2$ .

*Cobalt Sulphate*,  $\text{CoSO}_4$ .—An aqueous solution of a red colour. Thin wedge, oxygen-gas light.

At 20°, spectrum commences at  $\lambda$  715; all rays more refrangible were not interrupted by an absorption band sufficiently strong to obscure the cross-wires.

		$\lambda$
At 100° C. .	Spectrum begins at . . . . .	715
	<i>Absorption Band</i> , . . . . .	549 to 473
	Spectrum ends at . . . . .	413

No dark lines were observed in the violet, these being part of the solar spectrum, and doubtless the end of the visible spectrum fell short of that usually observed owing to the difference between oxygen-gas light and the sun-rays as a source of illumination.

When the liquid was hot, the dark shading of the absorption band became capable of measurement, but only at the top of the cell where the layer of liquid was thickest, instead of at the middle as was usual. This same solution was placed in a thick wedge-cell in order to measure this absorption band. It must be remarked that the solubility of the sulphate is less than that of the haloid salts of cobalt.

		λ
At 16° C.	Spectrum begins at . . . . .	673
	<i>Absorption Band</i> , . . . . .	<b>544 to 464</b>
	Spectrum ends at . . . . .	407
At 100° C.	Spectrum begins at . . . . .	685
	<i>Absorption Band</i> , . . . . .	<b>613 to 649</b>
	Spectrum ends at . . . . .	406

The green rays were so shaded in the above spectrum as to appear of a dark olive green colour fading into the blue. On heating, they became black. The absorption thus became complete.

*Cobalt Nitrate*,  $\text{Co}(\text{NO})_2$ .—Aqueous solution. Thick wedge. Gas-light. (Plate XXI.)

		λ
At 16° C.	Spectrum begins at . . . . .	724
	<i>Absorption Band</i> , . . . . .	<b>491 to 479</b>
	Spectrum ends at . . . . .	416
At 100° C.	Spectrum begins at . . . . .	696
	<i>Absorption Band</i> , . . . . .	<b>491 to 479</b>
	Spectrum ends at . . . . .	416

Small glass of a deep blue tint. Two thicknesses.

Spectrum begins at . . . . .	718
First <i>Absorption Band</i> , . . . . .	<b>665 to 581</b>
Second ,, ,, . . . . .	<b>549 to 513</b>
Spectrum ends at . . . . .	400

A rise of temperature has no effect on these measurements, though the glass be heated by a Bunsen burner until near the temperature when it begins to soften.

It is thus rendered perfectly clear that anhydrous substances do not undergo any change in composition which is indicated by a change in their spectra on rise of temperature.

The experiments of Tichborne,\* made chiefly on the cobalt and copper chlorides, are similar to those of von Babo† and of Schiff.‡ With dilute solutions in sealed tubes at high temperatures, he obtained apparently the same changes of colour as those I have shown are produced in saturated solutions when heated to 100° C.

All cobalt salts are stated by Bersch§ to be turned blue by heat. The nitrate does so just at the temperature when decomposition of the salt commences; but this cannot in any way be said of the sulphate which may be heated to redness without change. In the case of cobalt nitrate, it is not improbably due to the formation of an oxynitrate; for a blue oxynitrate may be produced by precipitation with alkali, and an intermediate product of the decomposition of cobalt nitrate by heat would probably be an oxynitrate or basic salt.

The view formerly held, that the haloid salts of cobalt and copper when dissolved, and the solution diluted, were decomposed into hydrochlorides of cobaltous or cupric hydroxides, has been recently revived in a modified form by supposing that these and other salts are hydrolysed.

On the authority of Winkelblech,|| it has been stated that the blue precipitate formed by caustic alkali in cobalt chloride solutions is a basic salt, which, by the action of water, is converted into a pink hydroxide. I have completely confirmed this observation, and distinctly shown that the salts are not hydrolysed, the evidence being of the following character:—

When cobalt chloride, bromide, or iodide is mixed with a solution of barium hydrate or of potassium or sodium hydroxides, the liquid being contained in a Torricellian vacuum, and the metallic chloride being in excess in the solution, the salt precipitated is blue, and its composition is that of an oxychloride. It passes into the pink hydroxide by the continued action of water, and when exposed to the air, it undergoes simultaneously more or less oxidation. If washed with water continuously for three weeks, it is found that the salt is losing chlorine, but is still not freed from that substance, notwithstanding it has been in contact with from 1200 to 2500 times its volume of water. If the salt had been hydrolysed, it could not have survived the action of caustic alkali followed by a copious washing with water, and no oxychloride would have been formed, nor would its decomposition in presence of water have been so exceedingly sluggish. Another instance occurs in the case of the hydrated chromium chloride, which, when heated strongly, yields partly anhydrous chromium chloride, and partly chromium oxide. This salt could not have been hydrolysed in its solution or the insoluble  $\text{CrCl}_3$  would not have been formed.

\* Chem. News, vol. xxv., p. 133, 1872.

† Jahresbericht, 1857, p. 72.

‡ Ann. Chem. Phar., cx., p. 203.

§ Wiener Akad. Berichte, lvi. (2), p. 724.

|| Annalen der Chemie, vol. 13, 148, 253.



PART III.

The Action of Heat on the Absorption Spectra of Chromium Salts.

		λ
<p><i>Green Chromium Chloride</i>.—Thin wedge-cell. Gas light. A solution of <math>\text{Cr}_2\text{O}_3 \cdot 16\text{H}_2\text{O}</math> in hydrochloric acid. Not precipitable by ammonium oxalate.</p>	At 20°	Spectrum begins at . . . . . 724 First <i>Absorption Band</i> , . . . . . <b>704 to 685</b> Second " " " " . . . . . <b>673 to 538</b> Spectrum ends, . . . . . 500
	At 100°	Liquid nearly opaque. No measurements possible.
<p><i>Chromium Sulphate</i>, <math>\text{Cr}_2(\text{SO}_4)_3 \cdot 15\text{H}_2\text{O}</math>.—Blue or violet salt. Thin wedge-cell. Deep blue solution.</p>	At 20°	Spectrum begins a little below B, λ 687, . . . . . 691 Rays transmitted to . . . . . 610 <i>Absorption Band</i> , . . . . . <b>610 to 566</b> Rays transmitted to . . . . . 475
	At 100°	Spectrum begins at . . . . . 666 Rays transmitted to . . . . . 627 <i>Absorption Band</i> , . . . . . <b>627 to 573</b> Spectrum ends at . . . . . 497 (See figs 3 and 4, Plate XXI.)
<p><i>Green Chromium Sulphate</i>, <math>\text{Cr}_2(\text{SO}_4)_3 \cdot 5\text{H}_2\text{O}</math>.—Produced from the violet salt by heating to 100°.</p>	At 16°	Rays transmitted from . . . . . 520 to . . . . . 465 No well defined spectrum.
	At 16°	Spectrum begins at . . . . . 662 Rays transmitted to . . . . . 562 <i>Absorption Band</i> , . . . . . <b>562 to 525</b> Spectrum ends at . . . . . 423
<p><i>Violet Chromium Sulphate</i>, <math>\text{Cr}_2(\text{SO}_4)_3 \cdot 15\text{H}_2\text{O}</math>.—0.5 gr. in 4 c.c. of <math>\text{H}_2\text{O}</math>.</p>	At 100°	Spectrum begins at . . . . . 662 Rays transmitted to . . . . . 577 <i>Absorption Band</i> , . . . . . <b>577 to 526</b> Spectrum ends at . . . . . 444
	At 16°	Spectrum begins at . . . . . 662 Rays transmitted to . . . . . 575 <i>Absorption Band</i> , . . . . . <b>575 to 526</b> Spectrum ends at . . . . . 442
<p><i>Green Modification</i>, <math>\text{Cr}_2(\text{SO}_4)_3 \cdot 5\text{H}_2\text{O}</math>.—0.5 gr. in 4 c.c. of <math>\text{H}_2\text{O}</math>.</p>	At 16°	Spectrum begins at . . . . . 715 Rays transmitted to . . . . . 627 <i>Absorption Band</i> , . . . . . <b>627 to 557</b> Spectrum ends at . . . . . 449
	At 50°	Spectrum begins at . . . . . 715 Rays transmitted to . . . . . 627 <i>Absorption Band</i> , . . . . . <b>627 to 557</b> Spectrum ends at . . . . . 464
	At 100°	A little light transmitted between . . . . . 548 & 500 (See figs. 1 and 2, Plate XXI.)
<p><i>Chromic Nitrate</i>, <math>\text{Cr}(\text{NO}_3)_3 \cdot 9\text{H}_2\text{O}</math>.—Violet coloured salt.</p>	At 16°	Spectrum begins at . . . . . 715 Rays transmitted to . . . . . 627 <i>Absorption Band</i> , . . . . . <b>627 to 557</b> Spectrum ends at . . . . . 449
	At 50°	Spectrum begins at . . . . . 715 Rays transmitted to . . . . . 627 <i>Absorption Band</i> , . . . . . <b>627 to 557</b> Spectrum ends at . . . . . 464
	At 100°	A little light transmitted between . . . . . 548 & 500 (See figs. 1 and 2, Plate XXI.)

			$\lambda$
<i>Chromium Nitrate</i> (uncrystallizable).— Solution diluted, being otherwise too opaque.	At 20°	Spectrum begins at . . . . .	673
		Rays transmitted to . . . . .	588
		<i>Absorption Band</i> , . . . . .	<b>588 to 557</b>
	At 100°	Spectrum ends at . . . . .	481
		Spectrum begins at . . . . .	673
		Rays transmitted to . . . . .	588
	<i>Absorption Band</i> , . . . . .	<b>588 to 557</b>	
	Spectrum ends at . . . . .	481	
	<i>Violet Chromium Nitrate</i> .—0.5 gr. dis- solved in 4 c.c. of water.	At 16°	Spectrum begins at . . . . .
Rays transmitted to . . . . .			565
<i>Absorption Band</i> , . . . . .			<b>565 to 507</b>
At 100°		Spectrum ends at . . . . .	462
		Spectrum begins at . . . . .	667
		Rays transmitted to . . . . .	565
	<i>Absorption Band</i> , . . . . .	<b>565 to 507</b>	
	Spectrum ends at . . . . .	462	
	0.5 gr. heated to 100°, dissolved in cold water, and made up to 4 c.c.	At 18°	Spectrum begins at . . . . .
<i>Absorption Band</i> , . . . . .			<b>627 to 507</b>
Rays transmitted to . . . . .			438
<i>Chrome Alum</i> , $\text{KCr}(\text{SO}_4)_2 \cdot 12\text{H}_2\text{O}$ .	At 37°	Spectrum begins at . . . . .	685
		Rays transmitted uninterruptedly to . . . . .	470
	At 100°	Spectrum begins at . . . . .	685
		<i>Absorption Band</i> , . . . . .	<b>627 to 543</b>
		Rays transmitted to where spec- trum ends, . . . . .	503
		When hot the liquid is nearly opaque.	
<i>Chromium Oxalate</i> .—A solution of the violet-grey chromium hydroxide in oxalic acid.	At 20°	Spectrum begins at . . . . .	719
		<i>Absorption Band</i> , . . . . .	<b>706 to 685</b>
	At 100°	Spectrum begins at . . . . .	719
		<i>Absorption Band</i> begins at . . . . .	711
		Nothing visible beyond.	
A similar solution, No. 3.	At 18°	Spectrum begins at . . . . .	719
		<i>Absorption Band</i> , . . . . .	<b>704 to 689</b>
<i>Blue Potassium Chromoxalate</i> , $\text{K}_4\text{Cr}_2(\text{C}_2\text{O}_4)_6 \cdot 6\text{H}_2\text{O}$ .—Thin wedge-cell. Lamp-light. Readings made with great difficulty. Solution nearly opaque when hot.	At 20°	Rays visible at . . . . .	673
		<i>Absorption Band</i> , . . . . .	<b>627 to 497</b>
		Rays transmitted to . . . . .	481
	At 100°	Rays transmitted at . . . . .	673
		<i>Absorption Band</i> , . . . . .	<b>631 to 503</b>
		Rays transmitted to . . . . .	481
<i>Red Potassium Chromoxalate</i> , $\text{K}_2\text{Cr}_2(\text{C}_2\text{O}_4)_4 \cdot 10\text{H}_2\text{O}$ .—Thin wedge- cell. Lamp-light.	At 20°	Spectrum shaded to . . . . .	710
		Rays transmitted to . . . . .	694
		(1) <i>Narrow black band</i> at . . . . .	<b>694</b>
		(2) " " " " at . . . . .	<b>685</b>
	At 100°	<i>Absorption Band</i> , . . . . .	<b>633 to 478</b>
		End of spectrum, . . . . .	464
		Spectrum continuous at . . . . .	673
		<i>Absorption Band</i> , . . . . .	<b>588 to 537</b>
	Spectrum continuous to . . . . .	464	

*Notes on the Salts examined.*

*Chromium Chlorides.*—Chromium forms at least three chlorides, the anhydrous,  $\text{Cr}_2\text{Cl}_6$ , a lilac-coloured compound, is insoluble in water, but it slowly undergoes hydration, and then forms a green solution similar to that obtained when chromium hydroxide is dissolved in hydrochloric acid. But there are at least two varieties of the green chromic chloride, one precipitable by ammonium oxalate, the other not.

*Chromium Sulphate.*—The following experiment shows that the green compound is formed when the violet solution is heated, 0.5 grs. of violet chromic sulphate were dissolved in 4 c.c. of water. A like quantity of the salt was converted into the green compound  $\text{Cr}_2(\text{SO}_4)_3 \cdot 5\text{H}_2\text{O}$  by heating it in a water bath. It was dissolved in water, and made up to the same volume as the first solution. The two solutions were then examined in test-tubes of the same diameter.

*Chromic Nitrate*,  $\text{Cr}_3(\text{NO}_3)_9 \cdot 9\text{H}_2\text{O}$ .—Ordway prepared this salt,\* but it was also prepared and examined by me independently. Blue chromium hydroxide precipitated from chrome alum by ammonia was dissolved in nitric acid as long as the liquid remained blue. If it was seen to change to green, a little more nitric acid was added. The liquid was evaporated in an air-pump bell-jar, but it was difficult to obtain a crop of crystals. After remaining for some time in a desiccator, a number of octahedral crystals were deposited. A second and larger quantity of liquid yielded only an ounce weight of crystals in the course of two years. The mother liquor frequently becomes green and uncrystallizable after it has arrived at such a stage of concentration. The salt itself is of a deep violet colour; it becomes green at  $36^\circ$ , as Ordway has stated. It loses water of crystallization in a dry atmosphere and also at a very gentle heat.

The remarkable change in the spectrum on heating is shown in figs. 1 and 2, plate XX. b. The green rays alone were transmitted by the hot solution, but only a narrow and sharply selected band of these.

After cooling and keeping for some days the liquid had resumed its first condition and gave the original spectrum.

This substance is evidently unchanged by heating to  $100^\circ$ .

Experiments were then made with equal weights of the violet chromic nitrate, one portion being dissolved in water at  $16^\circ$ , the other being heated to  $100^\circ$ , and then dissolved in cold water ( $t = 18^\circ$ ), the two solutions being made up to equal volumes.

The spectrum is practically the same as that of the nitrate solution at  $100^\circ$ ; hence, the violet salt is converted into the green modification by heating the solution to  $100^\circ$ .

\* Phil. Mag., vol. 36, p. 205.

The work of Lapraik, "On the Absorption-Spectra of some Compounds of Chromium,"\* dealt chiefly with chromium salts of organic acids, the only inorganic compounds examined being chromium chlorides. His measurements agree with those given above; but as he examined greater thickness of liquid 2·5 c.m. or 1 inch, he noted more particularly the bands in the red. The thickness examined by me, in each case, was not more than two or three millimetres.

The chromium salts of oxalic acid examined by me, in 1874, were the following:—chromium oxalate, the red and blue potassium chromoxalates and a potassium-calcium chromoxalate.

*Blue Potassium Chromoxalate.*—The solution was almost opaque when hot; the second readings were made with great difficulty. It is evidently the fifth band in Lapraik's spectrum of a similar solution (2) which was measured above.

*Red Potassium Chromoxalate.*—A very fine spectrum, the blue rays well seen, the red and green very bright, red the brighter. The dark line observed by Brewster was not seen with this thin wedge.

It was difficult to reconcile these measurements with those of Lapraik (solution (5)), as he made use of a very much thicker layer of solution; accordingly a saturated solution of the salt at 16° was examined by sun-light, using a dispersion of four quartz prisms, and photographing the spectrum, because it is known that there is a powerful absorption in the ultra-violet. The liquid was contained in a test-tube 15 mm. in diameter, and the sun-rays were concentrated upon it, by a quartz condenser of 3-inch diameter and 6-inch focus.

A series of four photographs was taken at different temperatures: namely, 100°, 75°, 50° and 20°. The absorption is greatest at the highest temperature, where three bands in the red are easily seen, two of them degraded towards the less refrangible side. These bands are not as sharp as they would appear in a cell with parallel sides, the liquid being maintained throughout the exposure of the photographic plate at exactly the same temperature, because the bands widen by rise of temperature, and of course become narrow on cooling. (See Plate XXII.)

*The action of heat on the hydrated compounds of chromium is not simply a dissociation of water-molecules or of acid from base, but a true decomposition resulting in the production of a different class of salts with different generic properties.*

Regarding the salts of chromium and their change of colour by heat, let us examine, first, the observations of Schrötter on the chromic sulphates.† There is an anhydrous red insoluble salt,  $\text{Cr}_2\text{O}_3 \cdot 3\text{SO}_3$ ; a green uncrystallizable but soluble variety,  $\text{Cr}_2\text{O}_3 \cdot 3\text{SO}_3 + 5$  or  $6\text{H}_2\text{O}$ , and a blue crystallized modification,  $\text{Cr}_2\text{O}_3 \cdot 3\text{SO}_3 \cdot 15\text{H}_2\text{O}$ . The last can be converted into the second by desiccation at 100° C., by the action of a temperature of 65° C. or 70° C. on an aqueous solution;

\* Chemical News, vol. 67, pp. 207, 219, 231, 245, and 255, 1893.

† Gmelin's "Handbook of Chemistry," vol. iv., pp. 126–28.

if submitted to the temperature of boiled linseed oil, the red insoluble salt is formed. The red insoluble salt may also be made by adding a great excess of oil of vitriol to either a green or violet solution of chromic sulphate, and boiling till sulphuric acid is evolved; the red salt is then precipitated. Schrötter ascribes the change of colour when violet salts are heated to a loss of water of crystallization, his evidence consisting of the changes referred to above, the salt,  $\text{Cr}_2\text{3}(\text{SO}_4)$ , being unaffected throughout. Loewel\* supposes the violet solutions of chromium to contain normal, and the green, basic salts. Kruger† states that when a green solution of chrome alum, obtained by boiling the strong solution with water, is mixed with alcohol, the spirit takes up a portion of the acid, and the liquid then contains  $\text{K}_2\text{O}\cdot\text{Cr}_2\text{O}_3$ ; this green compound is converted into the violet by adding sufficient acid to reproduce  $\text{K}_2\text{O}\cdot\text{Cr}_2\text{O}_3\cdot 4\text{SO}_3$ .‡ Loewel experimented on solutions of chromium in hydrochloric acid. Two different nitrates of chromium exist—one hydrated and crystallizing in octahedra; the other green, uncrystallizable, and producible by heat. The violet crystals consist of a normal nitrate, with nine molecules of water.

Tichborne attributed the change of colour in chromium solutions when heated to a basic condition of the salt, and not to dehydration.§ His method of working was to heat a dilute solution of a ferric, aluminic, or chromic salt, either to  $100^\circ$ , or, under pressure, to a higher temperature, when the oxides separate out.

I have heated chromic sulphate,  $\text{Cr}_2\text{3SO}_4\cdot 15\text{H}_2\text{O}$  to  $100^\circ\text{C}$ ., when diluted with 10,000 times its weight of water, without the slightest turbidity resulting, and yet a saturated solution of the salt turns green at  $70^\circ\text{C}$ ., and remains perfectly clear. Having weighed all the evidence afforded by our knowledge of chromium compounds, I have obtained new facts leading to a definite conclusion as to the difference in constitution between violet and green salts of chromium. Loewel heated the compound obtained by dissolving chromic hydrate in hydrochloric acid to  $150^\circ\text{C}$ . The resulting compound, if heated to  $300^\circ\text{C}$ ., gives partly the violet insoluble chromic chloride,  $\text{Cr}_2\text{Cl}_2$ , and partly the green oxide,  $\text{Cr}_2\text{O}_3$ , hydrochloric acid being evolved. Therefore, Loewel's conclusion that the constitution of these compounds is that of chromic oxide, combined with hydrochloric acid, is not borne out by facts. That the ultimate change leaves chromium in combination with chlorine is evidence that these two elements were combined directly with each other in the first instance.

With modern formulæ, Loewel's first compound would be  $\text{Cr}_2\text{Cl}_6\cdot 3\text{H}_2\text{O}$ , and the second might be written thus,  $\text{Cr}_2\text{OCl}_4\cdot 2\text{H}_2\text{O}$ ; it is an oxychloride, and its formation may be thus expressed—



\* Journal für praktische Chemie, vol. xxxvii., p. 38.

† Pogg. Annalen, vol. lxi., p. 218.

‡ See also Siewert, Ann. der Chemie, vol. 127, p. 86.

§ Chemical News, 1871, p. 82.

The first action of a temperature of 300° C. is then represented as follows:—

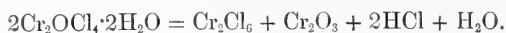

Schrötter's and Loewel's experiments lead to similar results, but are applied to different compounds.

When Kruger operated on a strong solution of chrome alum, he found that from the violet solution the original salt was precipitated by alcohol. If the solution was boiled until green, and alcohol then added, the green salt was precipitated as an oily liquid, and the alcohol contained a portion of the sulphuric acid. The change of colour, therefore, he said, was due to the production of a basic compound. On repeating this experiment, and extending it to other salts, such as the chromic sulphate and chromic nitrate, similar results were not obtained. I operated in the following way, taking four grams of each salt and dissolving it in 40 c.c. of water. The liquid was divided into two equal parts; one was precipitated by alcohol, the other was boiled, allowed to cool, and alcohol in gradually increased quantity added, but the result was only a green solution. The violet hydrated salts, therefore, are insoluble in alcohol, while the green compounds are soluble. It occurred to me that Kruger had added alcohol to the hot liquid, and so obtained a decomposition of the salt; I therefore took a boiled solution, cooled one-half, which still remained green, and made both liquids up to the same bulk with alcohol. The hot solution rendered a green oil-like precipitate; the cold one, however, did not do so. We cannot, therefore, consider it proved that a basic salt existed in both these solutions.

When the so-called chromic hydrate,  $\text{Cr}_2\text{O}_3 \cdot 9\text{H}_2\text{O}$ , is dissolved in nitric acid and kept quite cold, it forms at first a purple solution, but after a certain amount of the acid has been saturated, the solution turns green, the return to a purple colour being caused by a further addition of acid. The green solution is uncrystallizable; the purple, as I have already mentioned, does crystallize. Schrötter\* found that, if as much chromic hydrate as possible is dissolved in sulphuric acid, a green liquid results which contains the salt,  $\text{Cr}_2\text{O}_3 \cdot 2\text{SO}_3$  (A):—

Cr <sub>2</sub> O <sub>3</sub> , . . . .	50.19	50.68 per cent.
SO <sub>3</sub> , . . . .	49.81	49.31 „
	100.00	99.99

When a solution of this salt is boiled, a green precipitate separates which has the composition  $3\text{Cr}_2\text{O}_3 \cdot 2\text{SO}_3$  (B), with probably six molecules of water.

If the green solution obtained by boiling the violet salt be contained in the compound (A), it ought, on the addition of a large quantity of water and subsequent ebullition, to precipitate the compound (B). But it has already been stated that

\* Pogg. Annalen, vol. liiii., p. 513.

15,000 times its weight of water has no such effect. Is this due to the presence of free sulphuric acid in the liquid? The following experiment made with cold boiled chromic sulphate shows that such is the case, for potash was added in considerable quantity before a permanent precipitate was produced; when the perfectly clear liquid was filtered from any turbidity and boiled, a bulky precipitate was thrown down. When this precipitate has been washed free from all traces of sulphuric acid or potassium sulphate, it was dissolved in hydrochloric acid, and tested with barium chloride, which showed the presence of a considerable quantity of sulphuric acid in the substance. When a cold violet solution of chromic sulphate has a drop of alkali added to it, a precipitate is immediately formed, but this, on shaking, dissolves; repeated cautious additions of alkali cause the production of a green solution.

Two experiments were made to ascertain the amount of acid liberated by boiling a violet solution of chromic sulphate. Three grams of the salt were made up to 250 c.c. with water;  $\frac{1}{4}$ th of this being taken, was boiled, and standard alkali was added until the production of a permanent precipitate showed itself; then a further addition of alkali was continued until the absence of a green tint in the liquor indicated the entire precipitation of the chromium.

- (1) 50 c.c. required 34 c.c. of decinormal soda-solution to give a permanent precipitate and neutralised altogether 60 c.c.
- (2) 50 c.c. required 34.5 c.c. and 59 c.c. of soda.

A similar experiment was made with chromic nitrate: 2 grams were dissolved in cold water, and made up 250 c.c.; 50 c.c. of this solution required 27 c.c. of the standard alkali to cause precipitation of all the metal. One-third of this quantity or 9 c.c. were then added to 50 c.c. of the chromic nitrate solution, and on boiling with about a litre of water the insoluble basic compound was precipitated.

These numbers show the fact that 56.6 per cent. of the sulphuric acid in the salt was liberated from the violet salt when the solution was boiled. No doubt temperature and the strength of the solution will modify somewhat the amount of acid liberated.

The green colour is produced apparently independently of the amount of water in the solution, whereas, when a change of colour is owing to dehydration, it takes place only when at a much higher temperature after the addition of water.

Again, the long continued action of an air-pump vacuum in presence of oil of vitriol will give the green colour even to an efflorescent salt like the chromium nitrate. But we find the super-saturation of acids by chromic-hydrate, and the addition of alkali to the violet salts, showing the same changes as that on purple solutions of chromium compounds, while alcohol, a dehydrating agent, has no such action. Water, when added to a green solution, fails to produce the change which

would be expected of it if the green colour be caused by simple loss of water. These facts, taken together, suggest that the green solutions of chromium differ from the violet in the following manner:—

Salts of Chromium, Cr., Violet.		Salts of Chromyl,* Cr <sub>2</sub> O, Green.	
Chloride, . . . .	Cr <sub>2</sub> Cl <sub>6</sub> ·3H <sub>2</sub> O.	Chloride, . . . .	Cr <sub>2</sub> O·Cl <sub>4</sub> ·2H <sub>2</sub> O.
Sulphate, . . . .	Cr <sub>2</sub> 3SO <sub>4</sub> ·15H <sub>2</sub> O.	Sulphate, . . . .	Cr <sub>2</sub> O·2SO <sub>4</sub> ·7H <sub>2</sub> O.
Nitrate, . . . .	Cr <sub>2</sub> 6NO <sub>3</sub> ·9H <sub>2</sub> O.	Nitrate, . . . .	Cr <sub>2</sub> O·4NO <sub>3</sub> ·H <sub>2</sub> O.

The relation of the green to the violet compounds is similar to that existing between the salts of uranium and uranyl: as, for instance, the chloride—

Chloride of Uranium.	Chloride of Uranyl.
U <sub>2</sub> Cl <sub>2</sub> .	U <sub>2</sub> OCl.

If one-third the sulphuric acid in chromic sulphate is neutralised by sodium carbonate, experiment has shown that, though boiling does not precipitate a moderately strong solution, yet ebullition, with about 3000 times its bulk of water, causes a precipitate. This is caused by the formation, first, of chromyl sulphate, which is afterwards decomposed by water at 100° C. to produce the insoluble basic salt.

The view I have advanced of the constitution of the chromium salts was first published in the Proceedings of the Royal Institution of Great Britain for 1875, being contained in a report of a Friday evening lecture "On the Action of Heat on Coloured Liquids."† The experimental evidence was not communicated, but only an outline of the conclusions.

It has been confirmed of late years by the thermo-chemical researches of Recoura.‡ He found that the sulphate Cr<sub>2</sub>O<sub>3</sub>·3SO<sub>3</sub> was split into two molecules represented by 2Cr<sub>2</sub>O<sub>3</sub>·5SO<sub>3</sub> and H<sub>2</sub>SO<sub>4</sub>. When the sulphate was decomposed by alkali, a new hydroxide was formed which combines with only 2H<sub>2</sub>SO<sub>4</sub>; therefore Cr<sub>2</sub>O<sub>3</sub>·SO<sub>3</sub>, a green sulphate, was obtained, Cr<sub>2</sub>O<sub>3</sub>·3SO<sub>3</sub>·11H<sub>2</sub>O in the solid state, which is easily converted by water into the violet modification. It was also shown that, if the compound Cr<sub>2</sub>O<sub>3</sub>·3SO<sub>3</sub> is mixed with a sulphate, such as CuSO<sub>4</sub>, the two instantly combine to form a chromo-sulphate with the formula (Cr<sub>2</sub>4SO<sub>4</sub>)Cu; and that chrome alum, when partially dehydrated, becomes potassium chromosulphate (Cr<sub>2</sub>4SO<sub>4</sub>)K<sub>2</sub>·4H<sub>2</sub>O.

Cross and Higgin§ also have shown the existence of chromo-sulphates.

\* This was the name originally proposed in the paper from which this is an extract, but the compound CrO<sub>2</sub>Cl<sub>2</sub> is now called chromyl chloride.

† See also Proc. Roy. Soc., vol. 33, p. 372, 1875. Abstract, and also Chemical News, vol. 65, p. 15, 1892.

‡ Comptes Rendus, vol. 100, p. 1227; vol. 101, p. 435; vol. 102, p. 515, also pp. 548, 865, and 921; vol. 110, pp. 1029, 1193; vol. 112, p. 1439; vol. 113, pp. 857, 1037; vol. 114, p. 477.

§ Jour. Chem. Soc. Trans., vol. 41, p. 113, 1882.



The measurements of the spectra of chromium oxalate, and the blue and red salts derived from it were made by Lapraik, and are interesting since we know that these latter arise from the formation of a distinct chromoxalic acid as first propounded by Malaguti.\*

Both Clarke and Werner established the formula for the acid,  $H_6Cr_2(C_2O_4)_6$  by determining the constitution of the blue salts, but the acid itself was not isolated. Werner found the red salts to be represented by  $M_2Cr_2(C_2O_4)_4$ . From seven different reactions I deduced the existence of chromoxalic acid, and showed the relationship of the red to the blue salts.† But Lapraik showed from the spectra that there were two compounds formed by dissolving chromium hydroxide in oxalic acid, and he concluded they were two different chromoxalic acids corresponding to the red and the blue potassium salts.‡

## PART IV.

### Spectra of the Third Kind.

Of spectra interrupted by black bands or lines, we have five examples in the salts of uranium, of didymium (neodym and praseodym), samarium, and erbium. Potassium permanganate, also in a very dilute solution, shows seven bands in the blue and green, but their edges are not well defined.

The result of a large number of measurements of the bands seen in the spectra of uranium salts showed that no remarkable alteration occurred when they were heated. The measurements on each side of the different absorption bands remained identical or underwent a slight alteration when the temperature rose from  $16^\circ$  to  $100^\circ$ , showing that the bands were widened. Messrs. Morton and Carrington Bolton also arrived at the conclusion that heat did not affect their spectra.§

The spectra of salts of the rare earths are altered when their solutions are heated; and the extent and nature of the alterations will be seen from the measurements which are given.

Since this work was executed, the separation of compounds of neodym, praseodym, samarium, and thulium has been accomplished, and therefore the didymium salts must be regarded more or less as mixtures.

\* Comptes Rendus, vol. 16, p. 456; F. W. Clarke, Ber., vol. 14, p. 36; and E. Werner, C. S. Trans., vol. 51, p. 383, and vol. 53, p. 404.

† For instance, it was shown by me that potassio-calcium chromoxalate (Proc. Royal Soc., vol. xxi., p. 499) could be prepared by boiling calcium oxalate with Croft's salt, the red potassium chromoxalate. This is a very striking reaction. Proc. Chem. Soc., p. 4, 1887.

‡ Chem. News, vol. 67, p. 255, 1893.

§ Chem. News, vol. 27, pp. 47 to 270, 1872.

*The Spectrum of Didymium Chloride.*

The solution made in 1875 had merely the cerium separated from the other rare earths by the process of Mosander. The didymium hydroxide was precipitated and dissolved in hydrochloric acid, after which it was evaporated and crystallized. The earths, such as erbia, samaria, yttria, and the like, were not removed, but there was an imperfect separation of lanthana.

Measurements were made on each side of the broad bands both at 20° and at 100°. Accordingly they are not exactly comparable with those made by Lecoq de Boisbaudran and others, who adopted a reading at the maximum of absorption or at the centre of each band, because, from the absorption developing more strongly on one than the other, the strength of the solution alters the position of the mean reading. There is this also to be said, that solutions of different strengths yield different spectra; and it was also found that solutions containing the same quantity of didymium hydroxide converted into different salts yielded bands differing in intensity or position. This is partly due to differences in solubility, the sulphate, for instance, being much less soluble than the chloride, and in each case saturated solutions were used. But even when the solutions were not saturated, but diluted so as to contain the same quantity of base in equal volumes of liquid, the chloride differed from the sulphate, the nitrate, and the acetate.

*Didymium Chloride*,  $\text{DiCl}_2 \cdot 2\text{H}_2\text{O}$ .—Thick wedge-cell. The absorption bands are numbered.

BAND I.	(Red).	$\lambda$	$\lambda$
	At 20°, . . . . .	676	to 667
	At 100°, . . . . .	685	to 667

There is an erbium band at 6671 and another at 6839.

BAND II.	(Orange).	$\lambda$	$\lambda$
	At 20°, . . . . .	590	to 577
	At 100°, . . . . .	592	to 577

Bands of both praseo- and neodymium come together here. Pr. 5963 and 5886. Neo. 5824 and 5748.

BAND III.	(Green).	$\lambda$	$\lambda$
	At 20°, . . . . .	540	to 529, extending to 526
	At 100°, . . . . .	540	to 532, ,, 528

Neodymium occurs at 5313, and erbium at 5364.

BAND IV.	(Green).	$\lambda$	$\lambda$
	At 20°, . . . . .	521	to 519
	At 100°, . . . . .	522	to 519

Thalén gives a line of erbium 522·5 to 518.

## BAND V.

(Blue).

At 20°, . . . .	488 to 486,	extending to 481
At 100°, . . . .	488 to 486,	„ 481

There is a praseodymium line at 4823, and Thalén gives an erbium line at 487·7 to 486·5.

## BAND VI.

(Blue).

At 20°, . . . .	478 to 477
At 100°, . . . .	477 to 474

Probably praseodymium, 4823 to 4759.

## BAND VII.

(Blue).

At 20°, . . . .	467 to 455
At 100°, . . . .	469 to 453

There is a praseodymium band hereabouts, 4692.

## BAND VIII.

(Indigo).

At 20°, . . . .	403 to 449 (Neodymium).
At 100°, . . . .	All absorbed. Nothing visible.

As already mentioned in the Introduction, Bunsen,\* in 1886, examined the absorption spectra of salts of didymium both in the state of crystals and in solution, and found that they presented several differences. The width of the absorption bands varies with the thickness of the layer of solution and the quantity of the salt contained in it. Solutions of the chloride sulphate and acetate, each containing the same quantity of didymium, yielded different spectra, the bands being shifted towards the red with increase in the molecular weight of the salt.

It may be mentioned that H. Becquerel† more recently has observed such variations both in the crystallized salts and in their solutions. In any one salt the positions of the bands differ from those of the same salt in solution, and both in the solid and the state of solution the different salts slightly vary. In the measurements which he made he distinguishes the praseodymium from the neodymium, though the two were not separated.

But Becquerel's measurements were made with too small a dispersion to show any marked differences in the spectra of the solutions; and such differences as occur in the solids were shown by Bunsen to be due to double refraction, the ordinary and extraordinary rays exhibiting spectra with the same bands, but in different positions.

\* Ueber die Erscheinungen beim Absorptions-Spectrum des Didyms. Pogg. Ann., vol. 128, p. 100.

† "Sur les variations des spectres d'absorption du didyme." Comptes Rendus, vol. 144, pp. 777-780 and 1691-1693.

*Didymium Potassium Nitrate.*—Thick wedge-cell, sunlight.

From 30° to 60°.

Spectrum begins with a weak band at  $\lambda$  594.  
A feeble absorption extends from 594 to 588.*Absorption Band*—

588 to 581

*Absorption Band*—

533 to 530

*Absorption Band*—

523 to 521

Narrow *Absorption Bands* or lines—

488

478

*Absorption Band*—

454 to 449

At 100°.

Spectrum begins with a dark band at  $\lambda$  600.*Absorption Band*—

600 to 581. Feeble, narrow.

*Absorption Band* or line—

543

*Absorption Band*—

534 to 530

*Absorption Band*—

523 to 521

*Absorption Bands* or lines—

488

478

*Absorption Band*—

454 to 449

The measurement of the decided black band in the red was at 588 on the side of least refrangibility, and a faint shade extended farther in this direction to 594. On heating the solution the band thickened out to 600. In the thin wedge-cell the following measurements were the only ones possible:—

	<i>Band.</i>	<i>Band.</i>	<i>Narrow Band.</i>
At 20° . . . .	588 to 581	533 to 530	455
At 100°, . . . .	588 to 581	533 to 530	455

The narrow band at 455 was described in the note-book as a faint shade.

It will be seen that the principal band, which widens out from 630 to 581 when the solution is heated in the thick cell, here remains quite unchanged at 100°. The measurement at 543 is a feeble band like a line, not visible in the cold solution.

It may be mentioned that, at 588 and 581, the bands belonging to praseodym and neodym meet. The bands at 488 and 454 to 449 are probably due to erbium.

*Didymium Acetate.*—Thin wedge-cell.

At 20°.

Rays visible at 706.

*Absorption Bands*—*Red*, . . . . 685 to 673*Orange*, . . . . 588 to 572*Green*, . . . . { 533 to 529

. . . . { 522 to 519

*Blue*, . . . . { 491 to 488

. . . . { 481 to 478

Edge of a band at 476.

Edge of a band, 466.

*Broad Absorption Band*—*Blue*,\* . . . . 453 to 448

A dark line, 456.

At 100°.

*Absorption Bands*—

704 to 627

598 to 577

Beyond this all was obscured.

\* Probably an erbium band.

At the temperature of  $100^{\circ}$  a basic salt separated; and while this decomposition occurred, the black lines thickened, and those bands which form a group in the green became confused. Only four measurements could be made at this temperature on account of the turbidity of the liquid.

Iodide and bromide of didymium were prepared, but, as they readily decomposed, they were unsatisfactory salts to work with.

*Didymium Sulphate*.—A finely crystallized specimen, sparingly soluble in water. A saturated solution was made at  $20^{\circ}$ . It was photographed with the four-prism spectrograph, the plate being so adjusted, that the zero of the scale used in measuring the spectra was at the edge of the plate, and the red end of the spectra carefully focussed.

The illumination was sunlight, and the solution was contained in a test-tube half an inch in diameter. This salt is not very soluble, as it required more than forty times its weight of water to dissolve it at  $20^{\circ}$ .

## ABSORPTION BAND, I.

	$\lambda$	$\lambda$
At $20^{\circ}$ , . . .	5822	to 5750
At $100^{\circ}$ , . . .	5834	to 5750

## ABSORPTION BAND, II. (not so strong as I.).

	$\lambda$	$\lambda$
At $20^{\circ}$ , . . .	5333	to 5308
At $100^{\circ}$ , . . .	5333	to 5308

Rays transmitted and the spectrum terminates—

	$\lambda$
At $20^{\circ}$ , . . .	3344
At $100^{\circ}$ , . . .	3372

The spectrum begins at  $\lambda$  6198. The second band is much weaker than the first, and is less distinct at  $20^{\circ}$  than when the solution is hot.

It will be seen from these measurements and by inspection of more recent photographs, that at  $100^{\circ}$  the absorption bands have widened slightly, this being particularly noticeable in the first one, and slightly in the second, where it is seen to be shifted, apparently, but this is due to the band having widened on the weaker or less refrangible side when the solution was hot. The most remarkable change in the spectrum caused by rise of temperature is the increased absorption of the ultra-violet rays, which in the cold solution were entirely transmitted as far as the sun's spectrum could be photographed.

Having, in June last, the opportunity of photographing the absorption spectra of neodym-ammonium nitrate and praseodym-ammonium nitrate from small

quantities of these salts which Mr. Hugh Ramage was so good as to lend me, I herewith submit photographs taken with the 4-prism spectrograph. The dispersion of this instrument is considerable as may be understood by the measurements between the D<sup>1</sup> and D<sup>2</sup> lines being 0.045 and 0.05 mm. on different occasions; in wave-length the difference is only four tenth-metres, so that, at this part of the spectrum, 0.01 mm. of linear measurement is equivalent to a difference of  $\frac{1}{10,000,000}$ th of a millimetre in wave-length.

*Neodym-ammonium Nitrate*.—Solution was made by dissolving 2.8 grs. in 2.2 c.c. of water. It was placed in a thin wedge-shaped cell to be photographed.

*Praseodym-ammonium Nitrate*.—Solution was made by dissolving 1.9 grs. of the salt in 2.3 c.c. of water. It was photographed in a similar cell.

The position of the solar lines and of the absorption bands in cold and hot solutions is shown; and it will be observed how the bands in the hot solutions are widened out; also how the absorption increases at the end in the ultra-violet near the lines N and O, Pl. XXII. I beg to express my thanks to Mr. Hugh Ramage for the assistance he gave me, by the loan of these salts, and in other ways when photographing their spectra.

In a recently published paper,\* Muthmann and Stützel remark upon the great difference between the spectra of the nitrate, chloride, and carbonate of neodym. This last compound differs from the others, and possesses a somewhat intense blue colour. The intensity of the absorption was greatly increased; the band in the violet,  $\lambda$  432–434 was no longer visible, and that in the green was stronger than in the nitrate. There was a marked alteration in the wave-lengths of the bands, which showed a shifting towards the red end of the spectrum, the maximum of absorption in the bands being altered to the extent of 7.5 millionths of a millimetre of wave-length in the yellow and green. The neodym carbonate showed, in addition, a fine well-marked dark line in the orange† at  $\lambda$  600.5, which disappeared when the carbonate was converted into salts with mineral acids, but in the acetate, though much weaker, it was visible at  $\lambda$  5970. The relative intensities of the bands in praseodym carbonate, also the order in which the lines disappear upon dilution, are quite different from the nitrate and chloride. For instance, while in the nitrate solution the blue line is the most persistent, that in the yellow about  $\lambda$  596.5 is the last to disappear from the carbonate. As I have explained with regard to the absorption bands in organic compounds, the most persistent bands are those corresponding with the greatest amplitude of vibration.

The authors connect these alterations in the spectra with the state of electrolytic dissociation of the solutions, but meet with a difficulty in accounting for the

\* "Beiträge zur Spectralanalyse von Neodym und Praseodym," Berichte der Deutsch. Chem. Ges., vol. 32, p. 2653, 1899.

† Compare the didymium potassium nitrate and didymium acetate spectra already described.

acetate and carbonate yielding different ions from the chloride and nitrate, or, more precisely, they are at a loss to account for the neodym ion exhibiting a different spectrum when disengaged from these different salts.

From the point of view, which I have held for some years past, there is no difficulty whatever in accounting for these differences, for it is perfectly clear that the absorption spectra of such solutions are not derived from the metal alone or from the metallic oxide, but they are absolutely the property of the salt molecule as a whole, as I have shown to be the case with various organic substances, hydrocarbons, phenols, acids, bases, salts, and dyes, with didymium salts, and other metallic compounds. These absorption bands are as essential a characteristic of the respective salts as the six bands in the spectrum of benzene or the two or three bands in that of cymene. They follow the same rule with regard to the weighting of the molecule, and also as regards dilution and the gradual extinction of the bands. While reserving any opinion upon the question of whether electrolytic dissociation of salts in solution necessarily implies the complete decomposition of the salts into separate ions and a corresponding change in the spectra of the salts, I may remark that, at the present time, there is nothing in their spectra which can be regarded direct and conclusive evidence of this. The experiments of Ostwald,\* carried out on a variety of permanganates, really tell us nothing beyond the fact that great dilution caused the solutions to exhibit three absorption bands, which appeared to be practically identical, though one only of them was measured. The photographs show that the bands were vague, and this is, in fact, the character of all the seven bands, which are situated in the green and yellow region, where dispersion is small and the alteration in the wave-lengths of the absorbed rays is not easily measurable.

Ostwald, in fact, merely gives their positions, and not their wave-lengths. By increasing the dispersion so as to make differences in wave-length appreciable, the bands become so vague that there is nothing which can be measured with any certainty. It occurred to me, on examining the experimental evidence afforded by the spectra of these permanganates, that the differences in atomic weight of the basic elements forming the electro-positive ions of the salts were not sufficiently great to cause any considerable retardation of the intra-molecular vibrations which could be rendered visible at the red end of the spectrum; and that in order to test this matter, substances should be chosen which exhibit sharply defined bands either in the blue, violet, or ultra-violet, where the wave-lengths are shorter and the dispersion greater without loss of definition. In fact, ultra-violet absorption spectra are much more sharply defined than those in the regions of larger wave-length in the direction of the red.

From the salts of didymium, chloride, sulphate, nitrate, and acetate, and also

\* *Zeitsch. für physik. Chemie.*

from the spectra of other saline solutions, such as those of cobalt, nickel, and copper, the following deduction was drawn:—

*The absorption spectra of different salts of the same metal, whether solid or in solution, are not identical, even when the spectrum is a marked characteristic of the metal.*

From the examination of organic substances, whether salts of bases or otherwise, it was concluded that—

*Molecules of compounds—that is to say, molecules composed of dissimilar atoms—vibrate as wholes or units, and the fundamental vibrations give rise to secondary vibrations, which stand in no visible relation to the chemical constituents of the molecule, whether these be atoms or smaller molecules.\**

This conclusion is generally applicable also to metallic salts of inorganic origin, as well as to organic compounds.

When anhydrous compounds are examined the same effect of heat is observed, but the only substance experimented upon was potassium permanganate, the absorption spectrum of which was first described by Vierordt. As there are seven bands in the yellow, green, and blue, of diminishing intensity, and not very sharply defined, it was necessary to examine solutions of different strengths so as to bring into prominence some of the weaker bands. Of course, the stronger bands increase in width, and even become confused as the weaker gain in intensity when stronger solutions are used; hence the measurements are not all comparable with those of Lecoq de Boisbaudran, who used one solution of fixed strength, containing 0.1 gr. of  $\text{KMnO}_4$  per litre.

*Potassium Permanganate,  $\text{KMnO}_4$ .*—A freshly prepared solution. Thin wedge-cell.

ABSORPTION BANDS.	ABSORPTION BANDS.
At 16°.	At 100°.
$\lambda$	$\lambda$
470 to 478	471 to 481
485 - 495	488 - 501
505 - 513	505 - 519
529 - 534	Confused and not measurable.

The mean of the numbers at 16° are 474, 490, 508, and 531.5. The figures of Lecoq de Boisbaudran, representing the maximum intensity of absorption, and for apparently the same bands, are 469.4, 486.1, 504.5, and 524.6. That they are not more nearly in agreement with the above is due to the fact that the maximum of intensity is not in a position intermediate between the two edges of a band, but lies a little to one side or the other. This particular solution shows

\* "Researches on the Relation between the Molecular Structure of Carbon Compounds and their Absorption Spectra." Part VII.—Trans. Chem. Soc., vol. 47, p. 685, 1885.



not only the widening of the bands by the action of heat, but also the way in which those in the green become confused and unmeasurable. It was the strongest of four solutions which were used.

It is difficult to make accurate measurements of these bands on account of their nebulous character. Light does not pass freely between them, but is subject to more or less absorption in the intervening spaces. It was also remarked that measuring four or five bands in permanganate occupied some time, during which the solution was maintained at  $100^{\circ}$ , and at this temperature, evaporation might occur; hence the figures obtained with the stronger solution might be judged to be the more correct. Nevertheless the effect observed with the weaker solutions, which admitted of the four principal absorption bands being measured, was not of any consequence, being, at the most, when there was any change at all, an increase in the width of a band by about a millionth of a millimetre of wave-length. The majority of the saline solutions could undergo no evaporation, because they were so concentrated that their boiling points were far in excess of  $100^{\circ}$  C., and they were not maintained at this temperature for any lengthened period.

## PART V.

### **On the Molecular Constitution and Dissociation Phenomena of Saline Solutions.**

A general statement appeared in the preliminary notice,\* and in the abstract of the original Paper.†

It has been already recognised that the absorption spectra of various salts of the same metal bear some resemblance to each other, but it is a mistake to suppose that they can all be described in general terms. For instance, all cupric salts are not blue, nor nickel green, nor cobalt salts red.

A careful comparison of the cupric salts or of the nickel and cobalt salts, with both in the anhydrous state, as well defined crystallized hydrated salts, and in solution, shows that each molecule has its own spectrum; and the colour is that of the molecule as a whole, and does not consist of the colour of a base added to that of an acid, or of the colour of one ion added to that of another, otherwise it would be easy to predict what would be the colour of any compound. It is quite otherwise when the salts are dissolved in water and the solutions greatly diluted. In this case, whatever the colour of the solution originally may be, it must approach more and more nearly to the absorption spectrum of water, according to the increased proportion of water present.

\*Proc. Roy. Soc., vol. xxii., p. 241, 1874.

†Proc. Roy. Soc., vol. xxiii., p. 372, 1875.

*Absorption Spectra modified by the Solubility of Salts.*

The solubility of salts in water modifies the absorption spectra of solutions; the less soluble salts of any metal form the paler solutions, as might be expected. This is evident on comparing the solutions of the sulphates of similar constitution, such as the sulphates of cobalt, nickel, and copper, with their corresponding chlorides and bromides. The sulphate of each is the least soluble compound.

*On the Action of Different Solvents.*

In so far as the solvent affects the chemical constitution of saline solutions, it is necessary to refer to two classes of solvents, those which are dehydrating agents and those which are not. To the former category belong alcohol, calcium chloride, hydrochloric acid, and, in a modified degree, glycerine. These substances produce, in various degrees, the same general effect as rise of temperature, that is to say, they convert red cobalt compounds into more or less blue liquids, and grass-green copper solutions into brown and opaque liquids. The variations, caused by the difference in solubility of the compounds in the different liquids, have been already mentioned; but it was found that variations in solubility were not involved in modifying the absorption of light in these particular instances; for when an alcoholic solution or a hydrochloric acid solution was diluted with more alcohol or acid, the colour of the liquid altered to no further extent than would have been the case upon the addition of a colourless solvent having no chemical action upon the solution. It did not change the character of the absorption spectrum, but only the depth of tint of the solution.

The action of hydrochloric acid upon solutions of hydrated salts is typical of that of other dehydrating liquids, and may therefore be explained more fully. Concentrated hydrochloric acid contains the anhydrous acid HCl, the heat evolved in the hydration of which exceeds that which accompanies the formation of  $\text{CoCl}_2 \cdot 6\text{H}_2\text{O}$  from the dihydrate  $\text{CoCl}_2 \cdot 2\text{H}_2\text{O}$ , or from the anhydrous chloride  $\text{CoCl}_2$ . Hence when solutions of the two are mixed, there is a change from red to blue caused by the partial or total dehydration of the cobalt chloride in solution. The same action occurs with cupric chloride, the change of colour is from green to brown, and the change of constitution of the solution, if, in the first instance, it is blue, is from that of a solution of the dihydrate  $\text{CuCl}_2 \cdot 2\text{H}_2\text{O}$ , to that of the anhydrous chloride  $\text{CuCl}_2$ . If the solution is green, it is a change from the monohydrate  $\text{CuCl}_2 \cdot \text{H}_2\text{O}$  to the anhydrous state within the solution.\* Examples with other chlorides could be cited, but these examples suffice to show the action of

\* Engel shows that cupric chloride combines with HCl. The formula of one salt is  $\text{CuCl}_2 \cdot 3\text{H}_2\text{O} \cdot \text{HCl}$ , C.R. 106, p. 273, 1888.

hydrochloric acid. In that of calcium chloride we have a similar action, but it is not so energetic. The action of alcohol has been clearly ascertained (see p. 272) to be also that of a dehydrating agent exerted upon the crystalline hydrate in solution. The dehydrating action of glycerine is aided by a rise of temperature.

Let us now consider the action of a solvent which is not a dehydrating agent. When six parts of uranyl nitrate  $\text{UO}_2(\text{NO}_3)_2 \cdot 6\text{H}_2\text{O}$ , or more precisely 6.1 parts, are dissolved in 4.4 parts of washed ether, the crystals enter into a perfectly definite and clear state of solution, from which they may be recovered unaltered by spontaneous evaporation. The ether is saturated with water, and it cannot therefore dehydrate the salt; but when  $\frac{1}{10}$  c.c. of water is mixed with 10 c.c. of this ether, or in the proportion of 1 volume of water to 100 of ether, the water separates as a distinct layer. But the solution of uranyl nitrate contains 1.307 parts of water in combination, or 21.43 per cent., and yet there is no separation into two layers of liquid. If the specific gravity of the ether be taken as 0.75, the proportion of water by volume to ether is as 1.307 to 3.3. Hence the water molecules in this solution form an integral part of the molecule of the uranium salt, and do not exhibit the physical properties peculiar to water. If, however, the uranyl nitrate crystals are moist, the moisture separates from the ether as an aqueous solution of the salt.

I. CONCLUSION.—*When a definite crystalline hydrate dissolves in a solvent which is not water, and is not a dehydrating agent, the molecule of the salt remains intact.*

#### *The Effect of Heat on Absorption Spectra.*

When saturated solutions of coloured salts are heated to  $100^\circ \text{C}$ ., there are few cases in which no change is noticed; generally the amount of light transmitted is diminished to a small extent by some of the more or less refrangible rays being absorbed. There is frequently a complete difference in the nature of the transmitted light. Anhydrous salts not decomposed, hydrated compounds not dehydrated at  $100^\circ$ , and salts which do not change colour on dehydration, give little or no alteration in their spectra when heated.

Solutions of hydrated salts, and most notably of haloid compounds, do change; and the alteration in the spectra, if not always absolutely identical with, is at least very nearly the same, as that produced by dehydration and by the action of dehydrating liquids (such as alcohol, acids, and glycerine) on the salts in the crystalline state or in solution. Allowance must be made for changes in the absorption spectra, owing to differences in the solubility of the anhydrous and the hydrated compounds at the particular temperature, and also in some cases for the different action of solvents on the spectra. The reason of this may be indicated by stating that the

anhydrous compounds are less soluble in such a liquid as alcohol than the corresponding hydrated salts; hence more light is transmitted through the same thickness of solution.

*Solutions of Anhydrous Salts.*

In those cases where a salt is anhydrous its solution is but slightly altered by rise of temperature, if it be altered at all; and such alteration is, as a rule, in the nature of that which would be caused by the concentration of the solution. In other words, it is slightly darkened by the absorption bands being intensified, or in some cases widened. This effect has been already noticed, and measured in salts of didymium.

*Reactions of Salts at different Temperatures.*

It is worthy of remark that substances which exhibit widely different spectra at different temperatures also give different reactions at these temperatures. In salts of chromium, the changes are particularly well marked; and they indicate a change in the constitution of the molecules of the salts which is not a simple dissociation of water-molecules. The thermo-chemical studies of Recoura have explained this action.

II. CONCLUSION.—*In any series of salts which are anhydrous, and which do not form well-defined crystalline hydrates, the action of heat up to the temperature of 100° C. does not cause any further alteration in their absorption spectra beyond that which is usual with substances which undergo no chemical change by such rise of temperature. The change is usually an increase in the intensity of the absorption or a slight widening of the absorption bands.*

It may here be explained that the increase in the intensity of the absorption does not necessarily alter the wave-lengths or the oscillation-frequencies of the absorbed rays; but it is to be explained by the increase in amplitude of the vibrations, whether these be molecular or of intramolecular origin. This is exactly the effect that might be expected to arise from the action of heat. Where the bands are slightly widened, and therefore the wave-lengths of the rays absorbed are necessarily slightly altered, the effect is precisely what is seen when using a more concentrated solution.

III. CONCLUSION.—*As a rule crystallized metallic salts, in which water is an integral part of the molecule, dissolve in water at ordinary temperatures without dissociation of the molecule.*

No more striking instances of the molecule remaining unchanged when it enters into solution can be quoted than those of the hexa-hydrated cobalt chloride;

the green hydrated nickel bromide; the green dihydrate, and brown hexa-hydrate of cobalt iodide.

The first is a familiar example: it is crimson, and readily changes to purple by loss of water on rise of temperature; the second salt consists of a rich grass-green aggregation of crystals. When dissolved in as little water as possible a similar dark green solution is formed. The latter salt occurs in dusky reddish\* brown hexagonal prisms, a saturated solution of which at 16° and 20° has a similar though deeper colour. Other illustrations of this are afforded by copper and nickel compounds. There are, however, a few salts, and these are generally very soluble substances, which do undergo sensible alterations in colour, which alterations have been observed in each case to correspond with that produced by a state of partial or complete dehydration. Such salts are the cupric chloride and the hydrated nickel bromide.

$\text{CuCl}_2 \cdot 2\text{H}_2\text{O}$ † is a pale blue salt; but its solution is grass-green, similar in colour to that of the monohydrated,  $\text{CuCl}_2 \cdot \text{H}_2\text{O}$ . When exposed to the action of moist air, the blue crystals absorb water, gain weight, and, in doing so, turn green, and become moistened with a solution of the salt. A green solution may be obtained which will not deposit the salt  $\text{CuCl}_2 \cdot 2\text{H}_2\text{O}$ , unless evaporated to such a degree that the whole liquid becomes nearly solid. This salt can scarcely be contained in the solution; it must be formed from the liquid as the salt solidifies.

$\text{CuBr}_2 \cdot 5\text{H}_2\text{O}$  is of a golden green colour; its solution in water is intensely dark brown, of the same colour as a solution of the compound  $\text{CuBr}_2$  when dissolved in alcohol or in a minimum of water. The brown solution can be obtained in such a condition that it does not deposit the salt  $\text{CuBr}_2 \cdot 5\text{H}_2\text{O}$ , but only the anhydrous salt  $\text{CuBr}_2$ . The salt  $\text{NiBr}_2 \cdot 6\text{H}_2\text{O}$  undergoes a similar change.

It may here be remarked that whether the brown solution of cupric bromide deposits anhydrous salt or the hydrate  $\text{CuBr}_2 \cdot 5\text{H}_2\text{O}$ , depends upon the temperature.

The following experiment shows how the hexahydrated cobalt chloride may be partially dehydrated by solution in a solvent other than water:—

The crystals were dissolved in strong alcohol of 98 per cent., or thereabouts, forming a beautiful deep blue solution; on partial evaporation, without heat, crystals were deposited, which, on analysis, proved to be the original hexahydrate. This is proved by the following analytical numbers:—At a temperature of 100°, 2 grs. of the salt lost 0.605 grs. of water, corresponding to 30.25 per cent. The conversion of the hexahydrate into the dihydrate at 100°

\* A statement in the last edition of Watts' Dictionary is, in this particular, inaccurate. The salt is described as being red.

† Jour. Chem. Soc., vol. 13, p. 256, 1875.

causes a loss of 30.29 per cent. On further heating the salt to 140°, a further loss of 0.185 grs. occurred, and the colour of the salt changed to a lavender blue in consequence of complete dehydration.

I have observed that the solid anhydrous salt becomes blue when hot, but becomes purple when cold.

It may here be noted that a specimen of cobalt chloride,  $\text{CoCl}_2 \cdot 6\text{H}_2\text{O}$ , well crystallized, has yielded the following numbers:—

When heated to 100° the loss of water was, in two analyses, (1) 39.06 per cent.; (2) 38.92 per cent.: consequently, as the hexahydrate contains 45.5 per cent., the compound dried at 100° contained 6.5 per cent. of  $\text{H}_2\text{O}$ . This corresponds to a salt, with the formula  $\text{Co}_2\text{Cl}_4 \cdot \text{H}_2\text{O}$ , or  $(\text{CoCl}_2)_2 \cdot \text{H}_2\text{O}$ , a hydrate which has not been previously obtained.

The blue solution in alcohol was proved not to be an alcoholate, but either the dihydrate or the anhydrous salt, and most probably the former. This is the nature of the evidence on that point. Equal quantities of 2 grs. of  $\text{CoCl}_2 \cdot 6\text{H}_2\text{O}$  were dissolved in absolute alcohol, and made up a volume of 5 c.c., but previous to solution one of these was completely dehydrated at 150°. In this second case, scarcely the whole of the salt dissolved, on account of its smaller solubility, though the other solution of the hydrated salt was easily made. The anhydrous salt,  $\text{CoCl}_2$ , dissolved with a superb ultramarine tint, which, on getting more concentrated, became darker and indistinguishable from the solution of the hydrated salt. The spectra of the two solutions were not identical, though the difference between them was but slight; and everything pointed to the conclusion that the hexahydrate, by solution in alcohol, is converted into the dihydrate.

The black cobalt iodide,  $\text{CoI}_2$ , dissolves in alcohol with an indigo blue colour; the vivid green bromide,  $\text{CoBr}_2$ , also with a blue colour; and the yellow cupric chloride,  $\text{CuCl}_2$ , with a brown colour. Exposure of these alcoholic solutions to the air yields hydrated compounds; while evaporation *in vacuo*, or over oil of vitriol, leaves the anhydrous salts.

The brown hexahydrated cobalt iodide,  $\text{CoI}_2 \cdot 6\text{H}_2\text{O}$ , is converted into the green,  $\text{CoI}_2 \cdot 2\text{HO}_2$ , when the former is dissolved in alcohol. The brown salt,  $\text{CoI}_2 \cdot 6\text{H}_2\text{O}$ , is a comparatively stable hydrate; it forms a brown solution in water, which becomes green at 50°, of the same colour as that of the solid  $\text{CoI}_2 \cdot 2\text{H}_2\text{O}$ , and also of the alcoholic solution.

The only purely physical change in the spectra effected by rise of temperature is a darkening of the solution; but, in these instances, the salts in solution must necessarily undergo a change in chemical constitution, which is recognised as dehydration.

Since the date of the foregoing experiments, the changes in colour of hydrated

cobalt chloride have been investigated by Potilitzin.\* He failed to obtain Bersch's compound  $\text{CoCl}_2 \cdot 4\text{H}_2\text{O}$ , as a distinct substance; the changes of colour from blue to red he attributed to dissociation, and pointed out that this takes place at a lower temperature when the salt is in solution than when in the solid state, and it is effected by such conditions as the concentration of the solution. He dissolved  $\text{CoCl}_2 \cdot 6\text{H}_2\text{O}$  in absolute alcohol, and evaporated the solution completely at a temperature of  $90^\circ$  to  $95^\circ$  C. The salt, obtained in the form of bluish crystals, had the composition  $\text{CoCl}_2 \cdot \text{H}_2\text{O}$ , as might be expected at this temperature; but, as I have already shown, evaporation at a temperature not exceeding  $20^\circ$  C. reproduces the original hexahydrated molecule.

A reference to the tabulated statement showing the changes in colour of saline solutions when heated, &c., will make it abundantly evident that all the phenomena observed, *e.g.* the several definite absorption spectra of the same solution at different temperatures, are due to dissociation within the solution.

\* Berichte, vol. xvii., p. 276, 1884.

[TABULATED STATEMENT





When a salt is put into water, the water may (1) combine with it, (2) decompose it, or (3) simply liquefy it. With one and the same salt it may depend upon the temperature whether combination, decomposition, or simple liquefaction will take place. The extent of chemical change depends upon—(a) the temperature, and (b) the quantity of water present. The behaviour of salts with water is different with different salts. But as combination is accompanied by heat evolution and simple liquefaction by heat absorption, there is a particular temperature, as Berthelot has shown,\* for each salt, at which when dissolution takes place, heat is neither evolved nor absorbed. Any temperature above this neutral point leads to dissociation of the hydrate in solution which is manifested in coloured salts by a change of colour. In point of fact, saline solutions of crystalline hydrates at ordinary temperatures contain the molecules of hydrated salts, more or less liable to dissociation, or even to complete dehydration. There may be several hydrates present at the same time in the same solution, and even the anhydrous salt may be present with them. Cupric bromide is a salt presenting a notable example, inasmuch as the black anhydrous compound can exist along with green pentahydrate,  $\text{CuBr}_2 \cdot 5\text{H}_2\text{O}$ ; and cobalt iodide is another for the hexahydrate  $\text{CoI}_2 \cdot 6\text{H}_2\text{O}$ ; and the dihydrate  $\text{CoI}_2 \cdot 2\text{H}_2\text{O}$  can exist together in presence of water. The colour of the mixture varies from a yellowish to a greenish brown, and passes through every shade of colour producible by mixing light passed through the red and green solutions in different proportions, or that of a ray of white light which has passed successively through the red and the green solutions.

Some of the hydrated salts are not always easily prepared; for instance, the copper compounds  $\text{CuCl}_2 \cdot 2\text{H}_2\text{O}$ , and  $\text{CuBr}_2 \cdot 5\text{H}_2\text{O}$ , the reason being that the most stable forms of these salts in solution are the molecules  $\text{CuCl}_2 \cdot \text{H}_2\text{O}$ ,  $\text{CuCl}_2$ , and  $\text{CuBr}_2$ .

The cupric bromide  $\text{CuBr}_2 \cdot 5\text{H}_2\text{O}$  undergoes a sort of black efflorescence at or about  $15^\circ \text{C}$ . in air not artificially dried, losing thereby 9 *per cent.* of its water of crystallization. But this salt deliquesces in moist air, and forms a solution of the anhydrous compound which is black, or in very thin layers intensely dark madder brown in colour. The peculiarity of this salt is that the balance in favour of efflorescence or deliquescence depends upon very small differences in the pressure of aqueous vapour in air at the ordinary temperature, and therefore corresponding in barometric pressure of not more than a few millimetres of mercury; so that on each side of a mean condition, we have the formation of two differently constituted molecules, which may be obtained in the form of solutions. Temperature, of course, plays a part in such changes, and complicates the conditions under which the substance crystallizes as a pentahydrate. For instance, the greenish golden crystals deliquesced to black or brown solution at  $15^\circ$ ; but the same salt crystallized

\* *Mécanique Chimique*, vol. ii., p. 160.

out in the golden prisms when the solution was cooled to 7°, the colour of the solution remaining unaltered.

A solution of cupric bromide, which had been evaporated gently by the aid of heat, but still at a low temperature, yielded no crystals at all when cooled from time to time out of contact with air to a temperature as low as 0·5° C. After repeated trials, it was found that the solution had a specific gravity of 1·8, and it seemed to be quite uncrystallizable. It then deposited only the black anhydrous salt, with a fine steely lustre on the faces of the crystals. When the salt so obtained was dried by keeping it for a time over oil of vitriol, it was transferred to a beaker glass, and exposed to air saturated with aqueous vapour at 15° to 17°, but generally at the lower temperature. It then lost its fine steely metallic lustre, swelled up, and became black like charcoal, while at the same time it gained in weight. During the night it became encrusted with the greenish, golden, prismatic crystals; and the minimum thermometer registered a temperature of 8°. These crystals disappeared when the surrounding air had been no warmer than 15°; and they were again reformed, on one occasion in profusion, when the temperature had been so low as 3·5°, and the air saturated with water vapour.

Similar results were observed with crystals of cupric chloride, which were pale blue at 15°, and a deep grass-green solution at 8°, recrystallizing to the blue salt at 15°, and again deliquescing to the deep green solution at the lower temperature, the air being saturated with moisture at the time.

IV. CONCLUSION.—*Crystallized hydrated salts, dissolved in a minimum of water at 20° C., undergo dissociation by rise of temperature. The extent of the dissociation may proceed as far as complete dehydration of the compound, so that more or less of the anhydrous salt may be formed in the solution.*

V. CONCLUSION.—*The most stable compound which can exist in a saturated solution at 16° or 20° is not always of the same composition as the crystalline solid at the same temperature, since the solid may undergo partial dissociation from its water of crystallization when the molecule enters into solution.*

*The Colour Relations of Solid Salts to those of the same Substances in Solution.*

The molecule  $\text{CuCl}_2 \cdot 2\text{H}_2\text{O}$  is a pale blue salt. (See p. 302.) When dissolved in an equal weight of water at 16° C., it forms a grass-green solution, darker than the solid substance. This may be observed with the deliquescing crystals. When five parts of water are added to this, the result is a clear blue liquid. The pale blue crystals of this salt spread over the bottom of a large porcelain dish, standing about three feet from a large window, and about twenty-five feet from a fire, were observed day by day for several weeks to be a green solution in the morning, and blue crystals in the afternoon, the variations in temperature being from 8° to 15°.

$\text{CuBr}_2 \cdot 5\text{H}_2\text{O}$  is a finely crystallized salt with a greenish golden colour. With one-third of its weight of water it forms an intensely dark madder brown solution. The added water here corresponds to about four molecules if the anhydrous salt were used, or six molecules with the above crystallized hydrate. If the saturated solution be mixed with  $1\frac{1}{4}$  to  $1\frac{1}{2}$  volumes of water, it is changed to a grass-green liquid; a further addition of  $1\frac{1}{2}$  volumes of water yields a blue solution; and if the addition of water be continued until the liquid is increased to seven times that of the original solution, a blue colour indistinguishable from that of cupric sulphate is the result.

The lustrous black anhydrous salt,  $\text{CuBr}_2$ , dissolves in water with the same brown colour, and undergoes the same colour changes upon dilution. It is remarkable to see the golden green crystals come out of the solution, which is almost black. There is also a remarkable similarity between the colour of the salt when partially dehydrated and that of the concentrated solution.

This cupric bromide,  $\text{CuBr}_2 \cdot 5\text{H}_2\text{O}$  (see p. 302), is a striking example of a peculiarly unstable condition which characterises the copper and nickel haloid compounds. The simple exposure of the crystals to ordinary undried air at or about  $16^\circ$  causes them to become of a very dark brown colour, almost black, and of the same colour as the solution; and at the same time that they undergo this change in colour, they lose as much as 9 *per cent.* of water. In other words, they effloresce and become brown. In this condition, the compound undergoes deliquescence in moist air, forming a very dark brown solution.

$\text{NiBr}_2 \cdot 6\text{H}_2\text{O}$ , rich emerald green crystals, behaves in the same manner as the cupric bromide; that is to say, it effloresces and becomes brown. A concentrated solution made by adding water to the amount of about one-third the weight of the salt is reddish brown. The amount of added water is from three to three and a-half molecules to one of salt. When two volumes of this solution are mixed with one and a-half volumes of water, the colour changes to a rich yellowish green; if made up to three times its original volume, the liquid is apple-green in colour.

It is quite evident that at  $16^\circ$  and  $20^\circ$ , the most stable hydrates of the foregoing compounds are  $\text{CuCl}_2 \cdot \text{H}_2\text{O}$ ,  $\text{CuBr}_2 \cdot \text{H}_2\text{O}$ , and  $\text{NiBr}_2 \cdot 2\text{H}_2\text{O}$ .

Nickel Iodide,  $\text{NiI}_2 \cdot 9\text{H}_2\text{O}$ , the bluish green crystals of the compounds behave like the cupric and nickel bromides. A solution made from the crystals, with a minimum of water, is of a yellowish brown colour.

The addition of  $2\frac{1}{2}$  volumes of water converts it into a yellowish green liquid, which does not undergo any further alteration by dilution.

#### *Solutions in Alcohol.*

The yellow anhydrous cupric chloride,  $\text{CuCl}_2$ , dissolves in alcohol with a brown colour. The dihydrated salt,  $\text{CuCl}_2 \cdot 2\text{H}_2\text{O}$ , dissolves in alcohol with

the same colour. It is impossible to believe that the latter compound is not dehydrated when it enters into solution in this case. I have failed to obtain any distinct compound of alcohol with cupric chloride; and, even if such could be formed, it is very unlikely that the colour of an alcoholate would be that of a solution of the anhydrous salt.

*On the Compounds formed in Aqueous Solutions.*

With regard to the exact compositions of the compounds formed when aqueous solutions are heated from  $20^{\circ}$  to  $100^{\circ}$ , there can be no doubt that  $\text{CuCl}_2 \cdot 2\text{H}_2\text{O}$ , on solution in water at  $16^{\circ}$  or  $20^{\circ}$ , if the solution be saturated, becomes  $\text{CuCl}_2 \cdot \text{H}_2\text{O}$ ; and, that by heating to  $100^{\circ}$ , at least a portion of the dissolved salt becomes  $\text{CuCl}_2$ , because the change is similar to that which is seen when this compound is dissolved in alcohol. At intermediate temperatures, we have mixtures of two or more compounds. Likewise, when a blue solution of cupric chloride, which undoubtedly contains  $\text{CuCl}_2 \cdot 2\text{H}_2\text{O}$ , is heated it becomes grass-green, and this change is precisely what we know to take place when the compound formed is  $\text{CuCl}_2 \cdot \text{H}_2\text{O}$ . Cupric bromide,  $\text{CuBr}_2 \cdot 5\text{H}_2\text{O}$ , undoubtedly forms the monohydrate,  $\text{CuBr}_2 \cdot \text{H}_2\text{O}$  when the solution is heated. The effect of heating a grass-green or even a blue dilute solution, the former of which certainly contains the compound  $\text{CuBr}_2 \cdot 5\text{H}_2\text{O}$ , is to convert it into a brown liquid, containing apparently the molecule  $\text{CuBr}_2 \cdot \text{H}_2\text{O}$ . Similar remarks are applicable to the nickel salts, the colour changes of the solutions being related in the same way to the colours of the salts in different states of hydration. These changes of colour can be accounted for only by dissociation, molecule by molecule of the water, from the molecules of the hydrated salts, or, what is the same thing, by the existence of different hydrates of the same salt in the solution at different temperatures, or in solutions with varying quantities of water at the same temperature.

When saturated solutions of these salts at  $15^{\circ}$  and  $20^{\circ}$  are diluted with water, heat is in each case evolved. This has been proved in a larger number of instances than those which have been referred to; but the following may be cited:—

A solution of 20 grs. of the pure crystallized  $\text{CuCl}_2 \cdot 2\text{H}_2\text{O}$  were dissolved in 20 grs. of water at  $16^{\circ}$ , with an evolution of heat equivalent to 3.6 units per kilo of the salts: this was then diluted with 100 grs. of water with a heat evolution of 28.8 units. It is evident that chemical combination had taken place between the cupric chloride and water upon its dilution with water.

*Cupric Bromide*,  $\text{CuBr}_2$ .—10 grs. of the black anhydrous crystals were drenched with 5.3 c.c. of water at a temperature of  $19^{\circ} \cdot 2$ ; the temperature rose to  $27^{\circ} \cdot 0$ .

Of the brown solution so formed, 5.0 c.c. at  $20^{\circ} \cdot 0$  were mixed with 4.2 c.c. of water at  $20^{\circ}$ , and the temperature rose to  $24^{\circ} \cdot 5$ , the liquid becoming green.

*Cobalt Bromide*,  $\text{CuBr}_2 \cdot 6\text{H}_2\text{O}$ .—10 grs. were drenched with 5 c.c. of water at  $15^\circ\text{0}$ , which caused the temperature to fall immediately, and it gradually sank to  $8^\circ\text{5}$ .

Some of the solid remained undissolved, as was the case with the copper salt. Of the solution, 5 c.c. were mixed with 5 c.c. of water, both liquids being at  $15^\circ\text{2}$ . The thermometer rose after the mixing to  $16^\circ\text{5}$ .

*Nickel Bromide*,  $\text{NiBr}_2 \cdot 6\text{H}_2\text{O}$ .—10 grs. of the large green crystals were drenched with 6 c.c. of water at  $14^\circ\text{5}$ . The temperature sank to  $11^\circ\text{0}$ . A saturated solution of the salt at  $16^\circ\text{3}$  was mixed with an equal volume or 5.0 c.c. of water at  $16^\circ\text{5}$ , when the temperature immediately rose to  $18^\circ\text{1}$ .

It is evident that in each of these experiments, the cold saturated solution of the salt combined with a further quantity of water to form a more complex molecule in the solution. The results are even more striking with cobalt iodide. In some cases the actual compounds contained in the diluted solutions have been determined by the extent to which the freezing point is lowered (Rüdorff);\* also from thermo-chemical measurements (Thomsen),† and from the vapour pressures of the solutions (De Coppet).‡

VI. CONCLUSION.—*Saturated solutions of hygroscopic and deliquescent salts combine with water when diluted to constitute molecules of more complex hydrated compounds in such solution.*

## VII.

In reviewing the facts already recorded, we arrive at the following statement which may be considered as a law:—

*When a saturated solution of a coloured salt undergoes a great change of colour upon dilution, or any remarkable change in its absorption spectrum due to the same cause, the dilution is always accompanied by a considerable evolution of heat.*

It is impossible to believe that the rise of temperature, upon dilution, is not caused by the formation of a complex hydrated molecule in the solution, because the change in colour is precisely that which occurs in the formation of the crystalline hydrates, and is the reverse of that of heat.

Arguments have been advanced by Ostwald,§ and supported by Ewan,|| from observations on the absorption spectra of very dilute solutions in favour of the electrolytic dissociation theory propounded by Arrhenius. "It is a necessary consequence of this theory that¶ the absorption spectrum of an electrolyte, which

\* Poggendorff's *Annalen*, vol. 114, p. 63, 1861, and vol. 145, p. 599, 1872.

† *Thermochemische Untersuchungen*, vol. iii., 1883.

‡ *Ann. de Chimie et de Phys.*, vol. xxv., 4th Series, p. 502; also vol. xxvi., p. 98, 1872.

§ *Zeitschr. physik. Chem.*, vol. 9, p. 579, 1892.

|| *Proc. Roy. Soc.*, vol. 57, p. 117, 1894.

¶ Nernst's "Theoretical Chemistry." English Edition, pp. 335-337, 1895.

is completely dissociated, should be made up additively from the absorption of rays by the positive and negative ingredients; and therefore that the colour of a dilute solution depends upon the colour of the free ions.”

In short, with sufficient dilution, all copper salts, cobalt salts, and nickel salts should show the absorption spectra, not of the salts, but of the atoms of copper, cobalt, and nickel, respectively, when charged positively with electricity, and should therefore, when the rays are submitted to the action of an equal number of ions, be practically identical for each metallic series of compounds, no matter what the salts may be, provided the negative ions are colourless. Ewan's experiments were ingeniously devised, and carried out with great care. More than a metre of liquid was used in each observation; and the coefficient of extinction was determined for each salt: nevertheless, his results were not in all cases concordant, which he believes was due to some of the salts, such as the acetates undergoing hydrolysis.

A discussion of this question lies outside the scope of the present communication; but it may be remarked that the facts in evidence of the formation of hydrated salts in solution, accompanied by a change of colour, and in a state of such concentration that electrolytic dissociation cannot have effected this change, have not been adequately taken into consideration. In this connexion, it has been stated by Ostwald\* that “changes of the same nature in absorption spectra are evidence of the same kind of molecular change”: and when we are dealing with very dilute solutions of hydrated copper, nickel, and cobalt salts the change of colour caused by dilution is in each case characteristic of the formation of more complex molecules, and not of much simpler ones, such as would result from the dissociation of the metallic salts into ions. We know the colour and absorption spectra of the complex molecules, but we do not exactly know the colour and absorption spectra of the ions which are of simpler constitution.

#### Summary and Conclusions.

When one substance simply dissolves in another, the result is a homogeneous mixture of the two substances in the liquid state.

When a salt dissolves at the ordinary temperature of the air, and without rise of temperature in a liquid which is without chemical action upon it, as a rule the salt is simply liquefied no matter what its constitution may be. Examples of this are afforded by the solution of uranyl nitrate in ether, of praseodym and neodym salts in alcohol or water, and of hexahydrated cobalt chloride and nickel chloride or copper sulphate in water. The spectrum of the solution is not the spectrum of the metal, but of the molecule, whatever it may be in solution. All copper salts

\* *Zeitschr. phys. Chem.*, 9, p. 579, 1892.

are not blue, nor nickel green, nor cobalt red; neither are the respective solutions blue, green, nor red. In the case of crystalline hydrates, with water as a solvent, it depends upon the temperature whether the salt is simply dissolved or converted into another substance, either by further hydration or by partial dehydration in solution. When a salt which is one of several hydrates is dissolved in water, the compound formed in the solution is that which at the particular temperature and degree of concentration of the solution has the greatest stability; it may be simply a homogeneous mixture of the original molecule with water, or of the anhydrous molecule and water, or it may be some intermediate compound according to the nature of the salt, but, in any case, it is that compound which has the greatest stability according to the mass and temperature of the solvent. If the solvent combines with water, the salt formed is that which has the greatest stability under the action of the dehydrating substance at the temperature of the solution.

When a deliquescent salt forms a saturated solution with water, the homogeneous mixture of the salt and water-molecules continues to absorb water as if the solvent substance were not present, that is to say, with evolution of heat until the saturation point has been attained. Slight variations in temperature affect the hydration of the solution, so that it gains or loses with depression and rise of temperature, respectively. Changes in colour and in absorption spectra, which are characteristic of solutions of anhydrous compounds, or of different solid hydrated salts, are also characteristic of aqueous solutions when placed under such conditions as would lead to the formation of such compounds, whether hydrated or anhydrous. For instance, when the temperature of the liquid is favourable to dissociation, then the hydrated molecule is dissociated from more or less of that water, which in the solid is called water of crystallization, and such dissociation occurs at a lower temperature than when the salt is in the solid state.

The action of heat on the absorption spectra of aqueous solutions of salts which do not form hydrates, is not characteristic of any chemical change, but merely of a *purely physical phenomenon* which may be explained by a greater amplitude in the molecular and intra-molecular vibrations. The effect is similar to that caused by concentrating the solutions. But if the absorption spectra of aqueous solutions containing hydrated salts undergo any marked alteration either in the amount of light or in the wave-length of the rays absorbed, this is always accompanied by a change in the composition of the molecule. The nature of the chemical change is either a dissociation of water from the molecules of the salt or a decomposition into a basic compound and free acid, which is a characteristic change when solutions of the blue or purple chromium compounds are changed to green upon raising the temperature of their solutions. In such cases, the reconversion of the solution into its original molecular condition either does not take

place at all, or it takes place very slowly, occupying days or weeks instead of minutes, and is not a result therefore simply of a reduction of temperature. In this it differs from dissociation as generally understood.

Taking any anhydrous series of salts of the same metal, the absorption bands shift towards the red the greater the molecular mass of the salt. This has been repeatedly shown in the case of organic substances,\* and there was no reason to believe that compounds entirely composed of inorganic elements would behave differently; but inasmuch as it might have been supposed that polymerisation had completely altered their properties, and therefore their spectra, it became necessary to ascertain whether this was really the case. It has been proved that these salts are not polymerised when they suffer dehydration, and therefore they do not deviate from the law discovered for organic compounds. It has also been shown in various hydrated salts, such as the sulphate, nitrate, and acetate of didymium, both in the solid and in the state of solution by Bunsen; in the chromium salts of organic acids by Lapraik;† and as the foregoing descriptions show, it is applicable to copper, nickel, and cobalt salts in the state of solutions. Etard‡ examined the spectra of chromium and cobalt solutions, and measured especially the bands in the red, which, as he observes, may be displaced or cease to exist with the same element, according to the nature of the molecules in solution or of the compound observed. In other words, the vibrations of the absorbed rays are of lesser frequency with the greater mass, the molecule being, so to speak, loaded, and its motion retarded.

When the molecule of any haloid salt of copper, nickel, or cobalt is combined with water, we find that the greater the state of hydration the larger the amount of light transmitted, or conversely the less the absorption. As examples, we have the chloride and bromide of copper, also nickel and cobalt, chlorides, bromides, and iodides.

This may be more generally stated in the following manner. In any series of hydrated compounds of the same salt, those with the largest amount of water in the molecule transmit the most light. The haloid nickel and cobalt salts are marked examples, also cupric bromide.

There are one or two instances where this may appear to be not strictly true,

\* "Researches on the Relation between the Molecular Structure of Carbon Compounds and their Absorption Spectra," *Trans. Chem. Soc.*, vol. 39, p. 153, 1881; vol. 41, p. 45, 1882; vol. 47, p. 685, 1885. Also *British Assoc. Report, Section B, Dover*. 1899, p. 15.

† Lapraik, *Jour. für prakt. Chemie* (2), 47, p. 305, 1883; also *Chemical News*, vol. 67, pp. 207–255, 1893.

‡ Étard, *Comptes Rendus*, vol. 120, p. 1057, 1895. It may be remarked that Lapraik attributed the shifting of the absorption towards the red to the greater complexity of the organic acid, and not directly to the increased molecular mass of the compound.



as, for example, with magnesium platinocyanide,\* the crimson colour of which becomes yellow and the crystals opaque by rise of temperature and loss of water ( $2\text{H}_2\text{O}$ ); but it must be remembered that the solution of the red salt is pale yellow or colourless.

When crystalline hydrated salts dissolve in water without molecular change in composition, the absorption spectrum of the solution is that also of the salt, the composition and colour of which is known; therefore any alteration in the spectrum must be the result of a change in composition corresponding thereto. Hence hydrated salts are seen to undergo dissociation at elevated temperatures. Also when saturated solutions are submitted to dilution, the colours of the solution correspond with those of the different known hydrates; and when these changes are accompanied by an evolution of heat, the conclusion is inevitable that these hydrates are formed.

Solutions of different salts of the same metal, the absorption spectra of the compounds of which are a marked characteristic, are not identical, but exhibit many variations. Here it is immaterial to what constituent or part of the molecule the characteristic of the spectrum is due. The vibrations of the absorbed rays are of lesser frequency the greater the molecular mass. But in comparing molecules of cobalt and nickel salts, the atomic mass being very nearly the same in these elements, and also in praseodym and neodym, the difference in the molecular mass of their salts is almost solely due to their non-metallic constituents; and if we select different salts of the same metal, the increase in molecular mass is entirely caused by the sum of the masses of the non-metallic constituents, and therefore the molecules of these compounds vibrate as wholes or units, and not as acid and base, or as electro-positive and electro-negative ions. This has already been pointed out in the following words:—

*“Molecules of compounds—that is to say, molecules composed of dissimilar atoms—vibrate as wholes or units, and the fundamental vibrations give rise to secondary vibrations which stand in no visible relation to the chemical constituents of the molecule, whether these be atoms or smaller molecules.”†*

Whatever their condition may be in enormously diluted solutions, in a state of moderate concentration the molecules of the salts remain absolutely unchanged in this respect at ordinary temperatures. Hence the molecule, as a distinct and

\* According to Buxhoevden and Tammann (*Zeitschrift für Anorganischen Chemie*, vol. 15, p. 319, 1897). There is a series of red hydrates formed between  $0^\circ$  and  $45^\circ$  C. (with from 6.8 to 8 molecules of  $\text{H}_2\text{O}$ ); at  $45^\circ$  a bright yellow hydrate with  $5\text{H}_2\text{O}$ ; at  $60^\circ$  one bright green,  $4\text{H}_2\text{O}$ ; at  $100^\circ$  a white hydrate with  $5\text{H}_2\text{O}$ ; and at  $210^\circ$  an orange red anhydrous salt.

† “Researches on the Relation between the Molecular Structure of Carbon Compounds and their Absorption Spectra.” Part VII. *Trans. Chem. Soc.*, vol. 41, p. 47, 1882; also *Brit. Assoc. Report*, Section B, Dover, 1899, p. 15.

individual particle, is very inadequately represented by our usual chemical formulæ, since these serve merely to symbolise certain well-known chemical reactions, but fail to express any relation between physical and chemical properties, or the dynamic conditions of the molecule. But as certain molecular groupings are characterised by the absorption of rays of particular wave-lengths (absorption bands), it is evidently possible to draw conclusions as to the constitution of substances from their absorption spectra.

#### CONCLUSIONS.

I. *When a definite crystalline hydrate dissolves in a solvent which is not water, and is without chemical action upon it, the molecule of the salt remains unchanged in chemical composition.*

II. *In any series of salts which are anhydrous, and which do not form well-defined crystalline hydrates, the action of heat up to the temperature of 100° C. does not cause any further alteration in their absorption spectra, beyond that which is usual with substances which undergo no chemical change by such rise of temperature. The change is usually an increase in the intensity of the absorption, or a slight widening of the absorption bands.*

III. *As a rule, crystalline metallic salts in which water is an integral part of the molecule, dissolve in water at ordinary temperatures, without dissociation of the molecule.*

IV. *Crystallized hydrated salts dissolved in a minimum of water at 20° C. undergo dissociation by rise of temperature. The extent of the dissociation may proceed as far as complete dehydration of the compound, so that more or less of the anhydrous salt may be formed in the solution.*

V. *The most stable compound which can exist in a saturated solution at 16° or 20° is not always of the same composition as the molecule of the crystallized solid at the same temperature, since the solid may undergo partial dissociation from its water of crystallization when the molecule enters into solution.*

VI. *Saturated solutions of deliquescent salts combine with water when diluted to constitute molecules of more complex hydrated compounds in such solution.*

VII. *When a saturated solution of a coloured salt undergoes a great change of colour upon dilution, or any remarkable change in its absorption spectrum due to the same cause, the dilution is always accompanied by a considerable evolution of heat.*

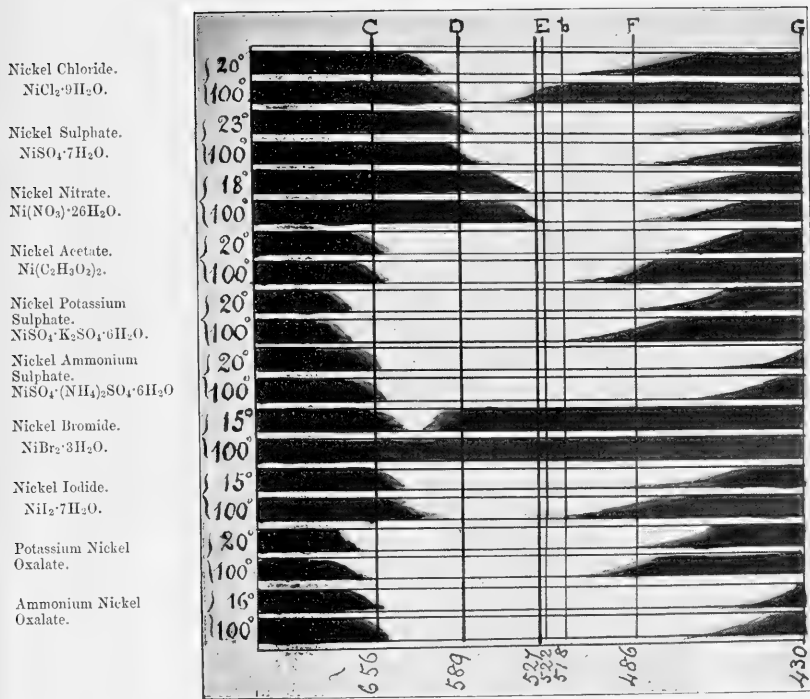

The Absorption Spectra of solutions of Nickel Salts at different temperatures. These solutions vary in colour from bluish green, grass-green, and yellowish green to brown and almost opaque liquids.



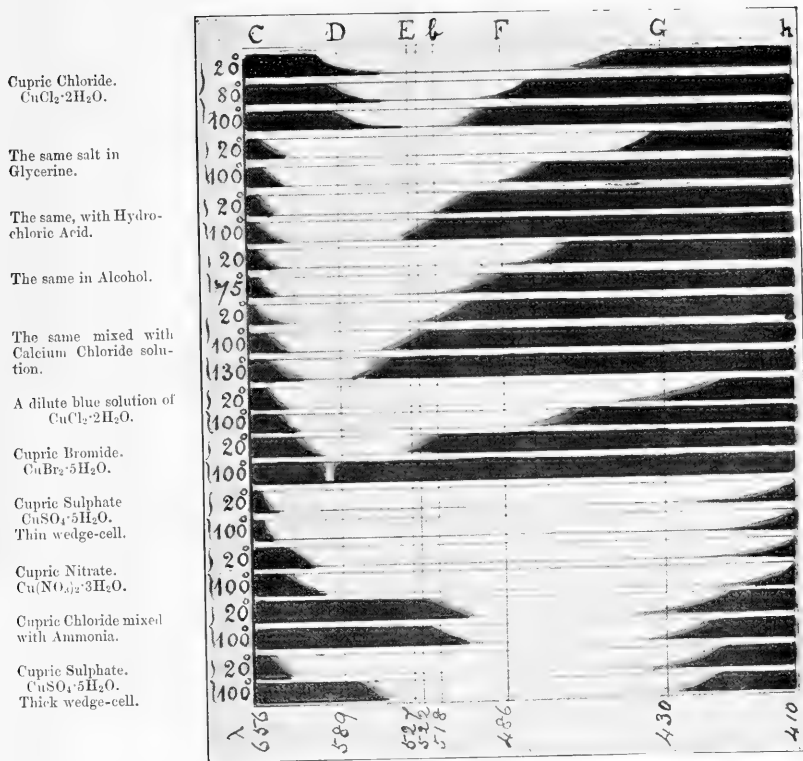

The Absorption Spectra of solutions of Copper Salts at different temperatures.



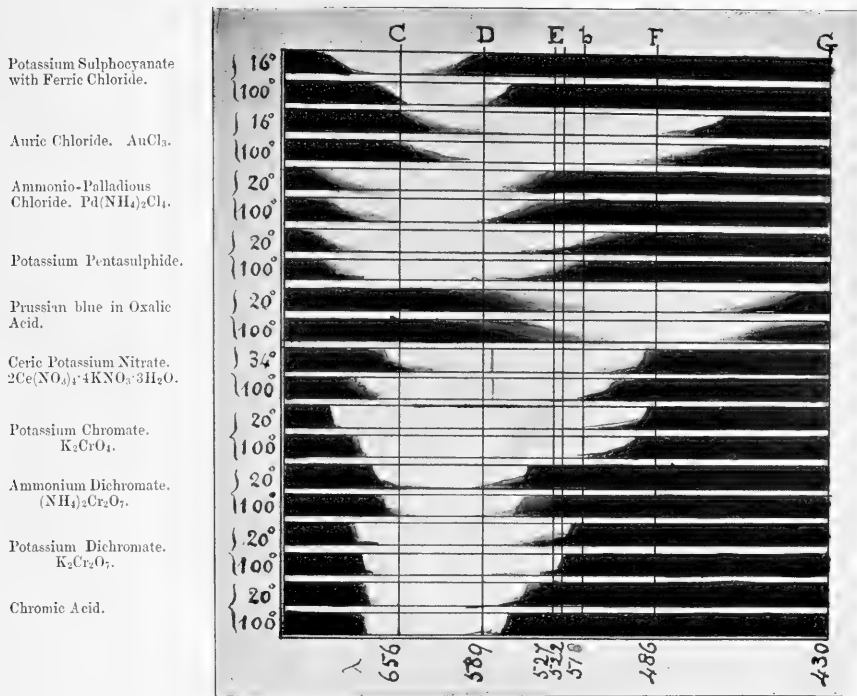

The Absorption Spectra of solutions of various Anhydrous Salts at different temperatures.  
 These show no marked alteration when heated.





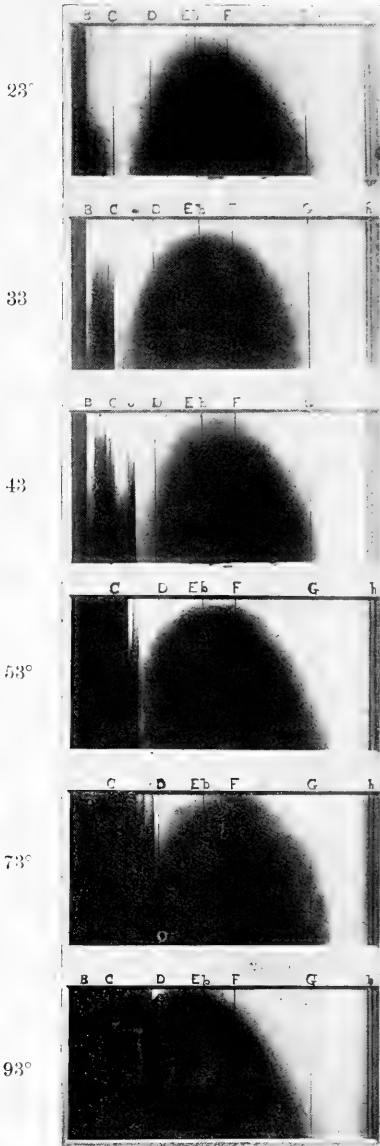

A.  
Spectra of saturated aqueous solution of Cobalt Chloride at different temperatures, showing dissociation of the molecules of Water from the Metallic Chloride.

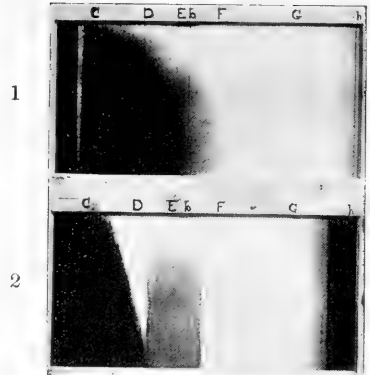

B.  
1. Anhydrous Cobalt Chloride dissolved in Alcohol.  
2. Solution of Cobalt Chloride mixed with Hydrochloric Acid.  
(Both solutions are unaltered by heat.)

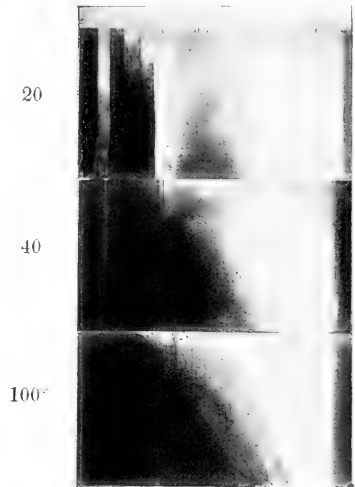

C.  
Spectra at different temperatures of a saturated solution of Cobalt Chloride mixed with a saturated solution of Calcium Chloride.



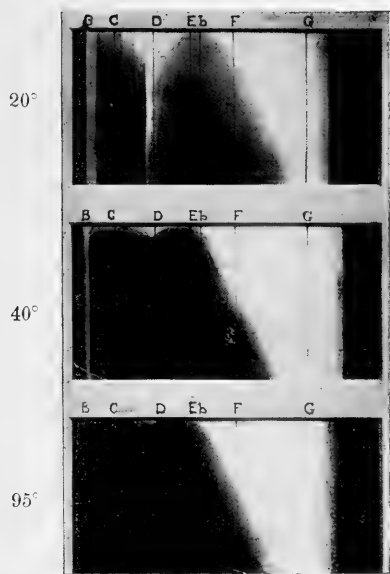

Solution of Cobalt Chloride in Glycerine at different temperatures.

1.  
Chromium Nitrate  
at 16°  
 $\text{Cr}(\text{NO}_3)_3 \cdot 9\text{H}_2\text{O}$ .  
A violet-coloured  
salt.

2.  
The same, at 109°.  
The colour has  
changed to green.

3.  
Chromium sulphate,  
at 20°.  
 $\text{Cr}_2\text{S}(\text{SO}_4)_3 \cdot 15\text{H}_2\text{O}$ .  
A blue or violet salt,  
yielding a deep  
blue solution.

4.  
The same, at 100°.  
The colour has  
changed to green.

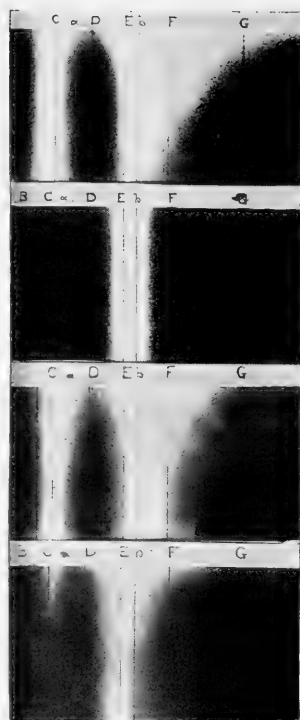

The spectra of solutions of Chromium Salts at different temperatures.



Absorption Spectra

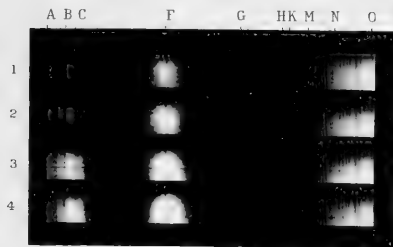

RED POTASSIUM CHROMALATE AT DIFFERENT TEMPERATURES  
 NAMELY: 1 AT 100°, 2 AT 75°, 3 AT 50° AND 4 AT 20° C

W. N. M. 11012

Absorption Spectra.



NEODYMIUM AMMONIUM NITRATE 1 AT 20° C. 2 AT 100° C.  
 PRASEODYMIUM AMMONIUM NITRATE 3 AT 20° C. 4 AT 100° C.

W. N. M. 11013



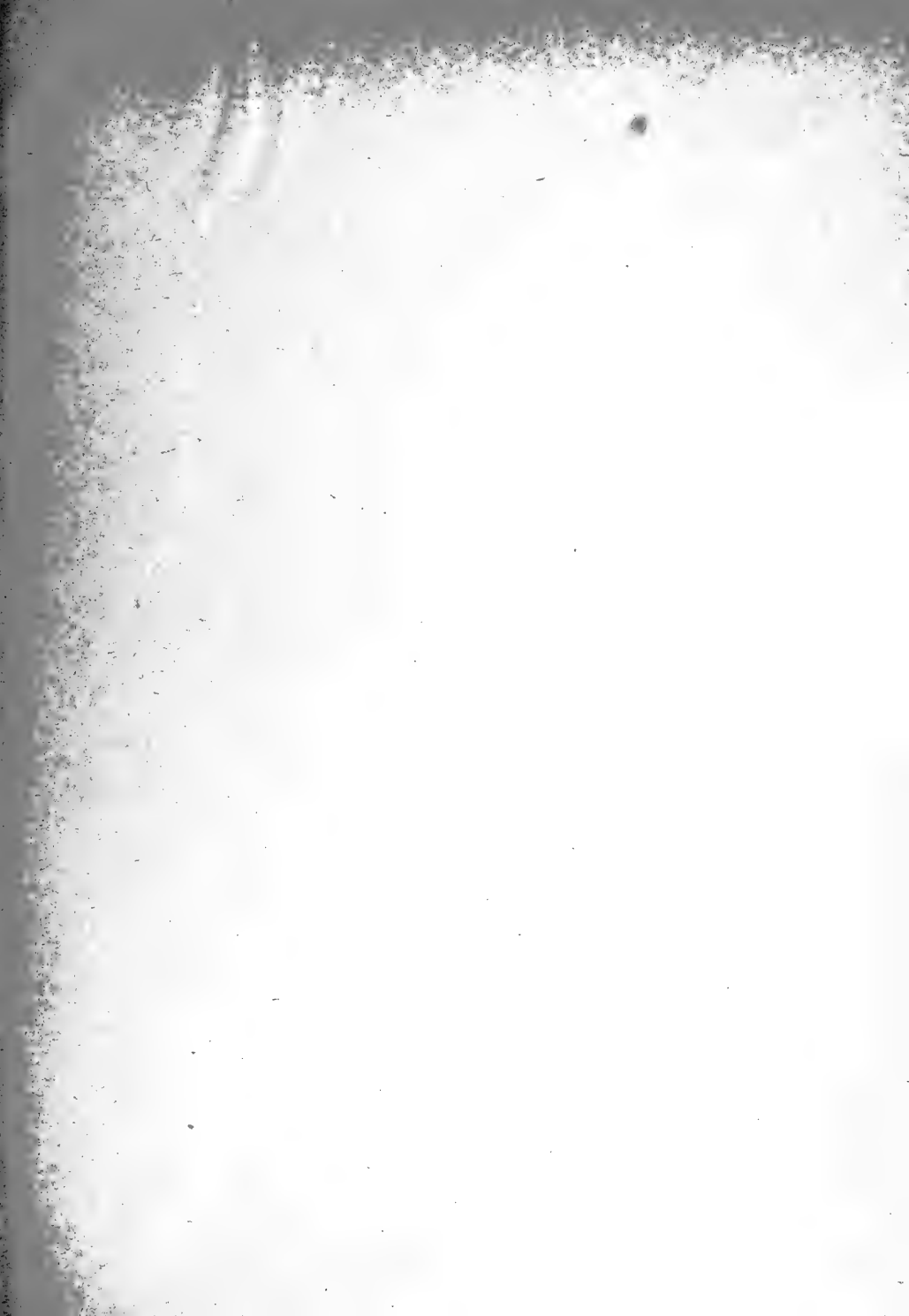

## TRANSACTIONS (SERIES II.).

---

VOL. I.—Parts 1–25.—November, 1877, to September, 1883.

VOL. II.—Parts 1–2.—August, 1879, to April, 1882.

VOL. III.—Parts 1–14.—September, 1883, to November, 1887.

VOL. IV.—Parts 1–14.—April, 1888, to November, 1892.

VOL. V.—Parts 1–13.—May, 1893, to July, 1896.

VOL. VI.—Parts 1–16.—February, 1896, to August, 1898.

---

### VOLUME VII.

#### PART

1. A Determination of the Wave-lengths of the Principal Lines in the Spectrum of Gallium, showing their Identity with Two Lines in the Solar Spectrum. By W. N. HARTLEY, F.R.S., and HUGH RAMAGE, A.R.C.S.C.I. Plate I. (August, 1898.) 1s.
2. Radiating Phenomena in a Strong Magnetic Field. Part II.—Magnetic Perturbations of the Spectral Lines. By THOMAS PRESTON, M.A., D.SC., F.R.S. (June, 1899.) 1s.
3. An Estimate of the Geological Age of the Earth. By J. JOLY, M.A., B.A.I., D.SC., F.R.S., F.G.S., M.R.I.A., Honorary Secretary of the Royal Dublin Society; Professor of Geology and Mineralogy in the University of Dublin. (November, 1899.) 1s. 6d.
4. On the Electrical Conductivity and Magnetic Permeability of various Alloys of Iron. By W. F. BARRETT, F.R.S.; W. BROWN, B.Sc.; R. A. HADFIELD, M. Inst. C.E. Plates II. to IX. (January, 1900.) 4s.
5. On some Novel Thermo-Electric Phenomena. By W. F. BARRETT, F.R.S., Professor of Experimental Physics in the Royal College of Science for Ireland. Plate IXA. (January, 1900.) 1s.
6. Jamaican Actiniaria. Part II.—Stichodactylinae and Zoanthæa. By J. E. DUERDEN, Assoc. R. C. Sc. (Lond.), Curator of the Museum of the Institute of Jamaica. Plates X. to XV. (January, 1900.) 3s.
7. Survey of Fishing Grounds, West Coast of Ireland, 1890–1891. X.—Report on the Crustacea Schizopoda of Ireland. By ERNEST W. L. HOLT, and W. I. BEAUMONT, B.A., Cantab. Plate XVI. (April, 1900.) 1s. 6d.
8. The Action of Heat on the Absorption Spectra and Chemical Constitution of Saline Solutions. By W. N. HARTLEY, F.R.S., Royal College of Science, Dublin. Plates XVII. to XXII. (September, 1900.) 3s. 6d.



[JULY, 1901.]

THE  
SCIENTIFIC TRANSACTIONS  
OF THE  
ROYAL DUBLIN SOCIETY.

VOLUME VII.—(SERIES II.)

---

IX.

ON THE CONDITIONS OF EQUILIBRIUM OF DELIQUESCENT AND  
HYGROSCOPIC SALTS OF COPPER, COBALT, AND NICKEL, WITH  
RESPECT TO ATMOSPHERIC MOISTURE. BY W. N. HARTLEY, F.R.S.,  
Honorary Fellow of King's College, London; Professor of Chemistry, Royal College  
of Science, Dublin.

(PLATES XXIII., XXIV., AND XXV.)

---

DUBLIN:  
PUBLISHED BY THE ROYAL DUBLIN SOCIETY.  
WILLIAMS AND NORGATE,  
14, HENRIETTA STREET, COVENT GARDEN, LONDON;  
20, SOUTH FEDERICK STREET, EDINBURGH; AND 7, BROAD STREET, OXFORD.  
PRINTED AT THE UNIVERSITY PRESS, BY PONSONBY AND WELDRICK.  
1901.

---

*Price One Shilling.*

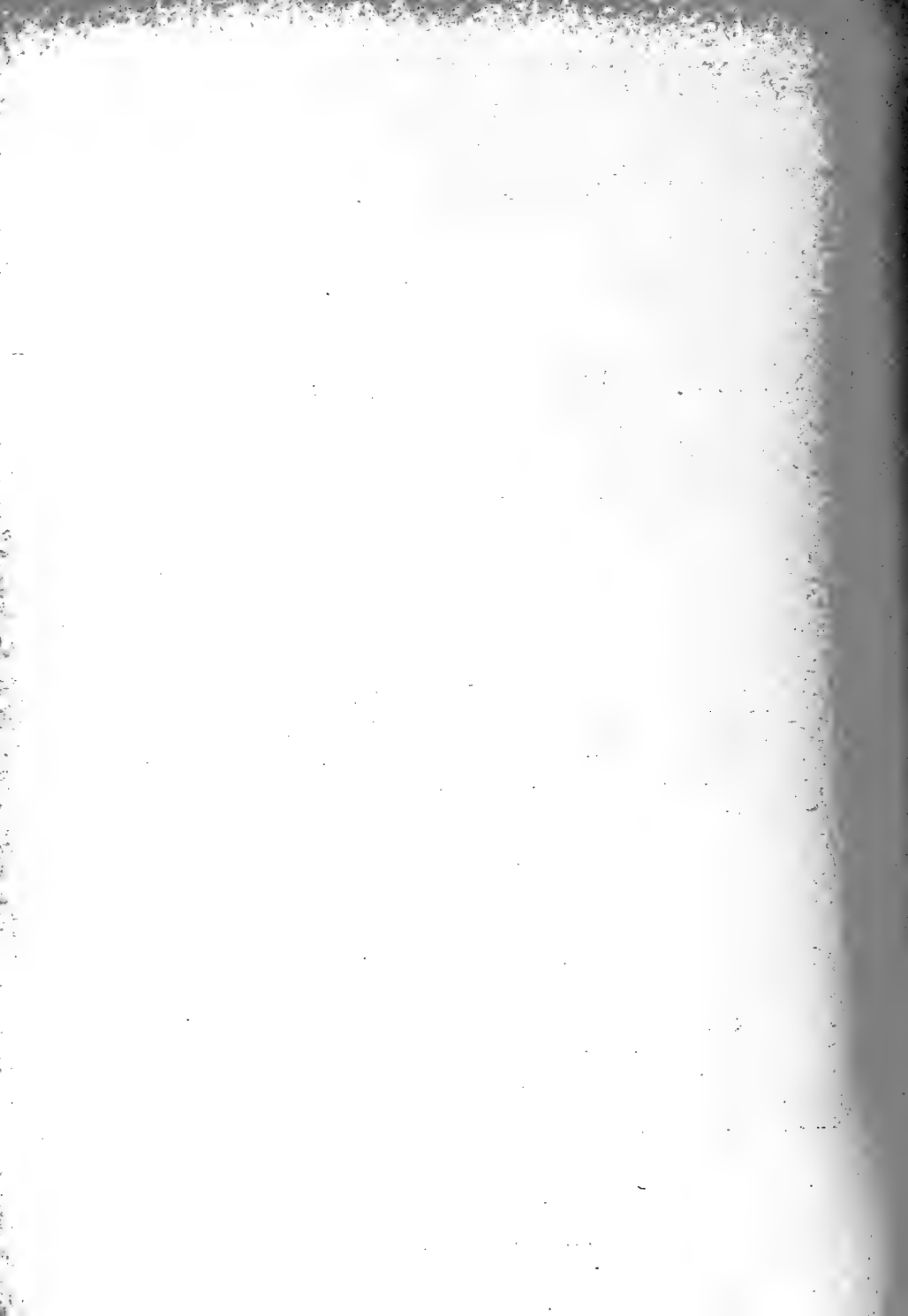

INDEX SLIP.

---

HARTLEY, W. N.—On the Conditions of Equilibrium of Deliquescent and Hygroscopic Salts of Copper, Cobalt, and Nickel, with respect to Atmospheric Moisture.

Roy. Dublin Soc. Trans., 2, vol. 7, 1898-1901, pp. 313-320.

Equilibrium of Deliquescent and Hygroscopic Salts of Copper, Cobalt, and Nickel, Conditions of, with respect to Atmospheric Moisture.

Hartley, W. N.

Roy. Dublin Soc. Trans., 2, vol. 7, 1898-1901, pp. 313-320.

Salts of Copper, Cobalt, and Nickel, Conditions of Equilibrium of Deliquescent and Hygroscopic, with respect to Atmospheric Moisture.

Hartley, W. N.

Roy. Dublin Soc. Trans., 2, vol. 7, 1898-1901, pp. 313-320.

1737-1738

... the Condition of the ... and ...  
... of ... and ... with respect to ...  
...  
...

... of ... and ...  
... with respect to ...  
...  
...  
...

... of ... and ...  
... with respect to ...  
...  
...  
...

[JULY, 1901.]

THE

SCIENTIFIC TRANSACTIONS

OF THE

ROYAL DUBLIN SOCIETY.

VOLUME VII.—(SERIES II.)

---

IX.

ON THE CONDITIONS OF EQUILIBRIUM OF DELIQUESCENT AND HYGROSCOPIC SALTS OF COPPER, COBALT, AND NICKEL, WITH RESPECT TO ATMOSPHERIC MOISTURE. BY W. N. HARTLEY, F.R.S., Honorary Fellow of King's College, London; Professor of Chemistry, Royal College of Science, Dublin.

(PLATES XXIII., XXIV., AND XXV.)

---

DUBLIN:

PUBLISHED BY THE ROYAL DUBLIN SOCIETY.

WILLIAMS AND NORGATE,

14, HENRIETTA STREET, COVENT GARDEN, LONDON;

20, SOUTH FREDERICK STREET, EDINBURGH; AND 7, BROAD STREET, OXFORD.

PRINTED AT THE UNIVERSITY PRESS, BY PONSONBY AND WELDRICK.

1901.



## IX.

ON THE CONDITIONS OF EQUILIBRIUM OF DELIQUESCENT AND HYGROSCOPIC SALTS OF COPPER, COBALT, AND NICKEL, WITH RESPECT TO ATMOSPHERIC MOISTURE. BY W. N. HARTLEY, F.R.S., Honorary Fellow of King's College, London; Professor of Chemistry, Royal College of Science, Dublin. (PLATES XXIII., XXIV., AND XXV.)

[Read MARCH 20, 1901.]

IN two published papers I have described some remarkable changes in colour which are seen on dissolving pure and neutral crystallized salts in water, and on dilution of their saturated solutions with water.\* The behaviour of cupric bromide was described; and the conclusion was drawn that both the chloride and bromide, with two and five molecules of water, respectively undergo partial dehydration when concentrated solutions are prepared at 60° F.

These conclusions appear to have been justified and confirmed by the following experiments, which were made with the object of ascertaining the conditions of equilibrium under ordinary atmospheric changes which govern the formation of hydrates of the hygroscopic and deliquescent haloid salts of copper, cobalt, and nickel.

## METHOD OF EXPERIMENTING.

A large bell-jar was placed on three blocks of wood an inch in thickness, and within the jar were six beakers, one of which contained distilled water. The other five were each weighed empty, and weighed again after adding a small quantity of one of the salts to be examined. Inside the jar dry and wet bulb thermometers were placed to determine the tension of aqueous vapour, and outside was a Six's maximum and minimum thermometer.

Every day, at as nearly as could be the same hour, the thermometer readings were recorded in the following manner:—

Time.	1899.	Dry bulb.	Wet bulb.	Max.	Min.	At instant.	Mean.
10 a.m.	Decr. 15th.	47°·5.	45°·5.	55°·5.	40°·25.	48°·0.	47°·9.

The pressure of aqueous vapour was found from the difference between the wet and dry bulb thermometers by reference to Glaisher's hygrometric tables.

\*Journ. Chem. Soc. of London, vol. xxviii., 1875, p. 206; Sci. Trans. Roy. Dublin Soc., vol. vii., ser. 11, 1900, pp. 253-312.

On frequent occasions, generally every third day, the beakers were weighed and the weights recorded opposite the columns containing the date and atmospheric conditions during the preceding twenty-four hours. These observations were continued from November 15th, 1899, to May 16th, 1900. It has not been thought necessary to include here the atmospheric conditions for every day during this period, but only on those days when the salts were weighed. In four cases the salts completely liquefied, but cupric bromide remained almost entirely solid, only minute drops of liquid being formed. The complete series of temperatures and weighings of the different salts, distinctly show that the tension of aqueous vapour under the conditions of the experiments varied only with the temperature, and was not sensibly affected by fluctuations of the barometer.

The air in the bell-jar had a humidity of generally over 85 per cent. of saturation, and often over 95 per cent. It might be expected to be maintained at saturation point, but as a matter of fact the deliquescent salts dried the air more rapidly than the water could moisten it.

Curves have been drawn showing the course of chemical change through the whole period; and the following tabulated statement of the weighings gives the composition of the hydrates formed in solution:—

## HYDRATED COMPOUNDS FORMED.

FORMULA.	TOTAL WEIGHT OF HYDRATE.		FORMULA.	TOTAL WEIGHT OF HYDRATE.	
	Calculated. Grs.	Observed. Grs.		Calculated. Grs.	Observed. Grs.
Original Salt, CuCl <sub>2</sub> ·2H <sub>2</sub> O.			Original Salt, CoBr <sub>2</sub> ·6H <sub>2</sub> O.		
CuCl <sub>2</sub> ·3H <sub>2</sub> O, . .	7·931	7·974	CoBr <sub>2</sub> ·16H <sub>2</sub> O, . .	10·394	10·444
CuCl <sub>2</sub> ·4H <sub>2</sub> O, . .	8·688	8·416 Not formed.	CoBr <sub>2</sub> ·17H <sub>2</sub> O, . .	10·764	10·720 to 10·770
Original Salt, CuBr <sub>2</sub> .			CoBr <sub>2</sub> ·18H <sub>2</sub> O, . .	11·132	11·145 to 11·136
CuBr <sub>2</sub> ·2H <sub>2</sub> O, . .	13·500	13·576	CoBr <sub>2</sub> ·19H <sub>2</sub> O, . .	11·502	11·379 Not formed.
CuBr <sub>2</sub> ·3H <sub>2</sub> O, . .	14·438	14·4354	Original Salt, NiBr <sub>2</sub> ·6H <sub>2</sub> O.		
CuBr <sub>2</sub> ·4H <sub>2</sub> O, . .	15·287	15·334 to 15·383.	NiBr <sub>2</sub> ·18H <sub>2</sub> O, . .	12·754	12·762 to 12·760
Original Salt, CoCl <sub>2</sub> ·6H <sub>2</sub> O.			Original Salt, NiI <sub>2</sub> ·7H <sub>2</sub> O.		
CoCl <sub>2</sub> ·8H <sub>2</sub> O, . .	4·240	4·277	NiI <sub>2</sub> ·19H <sub>2</sub> O, . .	4·600	4·593 to 4·613
CoCl <sub>2</sub> ·10H <sub>2</sub> O, . .	4·906	5·035	NiI <sub>2</sub> ·21H <sub>2</sub> O, . .	4·926	4·932 to 4·938
CoCl <sub>2</sub> ·11H <sub>2</sub> O, . .	5·187	5·246 to 5·186.	NiI <sub>2</sub> ·23H <sub>2</sub> O, . .	5·183	5·191 to 5·203
CoCl <sub>2</sub> ·12H <sub>2</sub> O, . .	5·472	5·254. Not formed.			



OBSERVATIONS ON HYGROSCOPIC AND DELIQUESCENT SALTS.

COLUMN I.—Date of observation.

„ II.—Tension of aqueous vapour in inches of mercury.

„ III.—Mean temperature of twenty-four hours.

W, weight of salt taken.

W', increase of weight per 100 parts of salt.

I.	II.	III.	CuCl <sub>2</sub> ·2H <sub>2</sub> O.		CuBr <sub>2</sub> .		CoCl <sub>2</sub> ·6H <sub>2</sub> O.		CoBr <sub>2</sub> ·6H <sub>2</sub> O.		NiBr <sub>2</sub> ·6H <sub>2</sub> O.		NiI <sub>2</sub> ·7H <sub>2</sub> O.		
			W	W'	W	W'	W	W'	W	W'	W	W'	W	W'	
1899.		°F													
November	15,				11·6207	100									
„	17,	61	7·1740	100			3·7608	100	6·7010	100	7·6789	100			
„	20,	59	7·2600	+1·20	11·9022	+2·423	3·8408	+2·13	7·2305	+7·90	8·0549	+4·90	3·1269	100	
„	22,	62	7·3292	2·16	12·0313	3·53	3·9263	4·14	7·4660	14·38	9·0639	18·04	3·4684	+10·92	
„	24,	59	7·3460	2·34	12·1207	4·30	3·9628	5·37	7·6650	14·38	9·0639	18·04	3·7684	20·52	
„	28,	57	7·4055	3·23	12·2587*	5·49	4·0531	7·77	7·9513	18·06	9·7909	27·50	4·0174	28·48	
„	28,	57	7·4055	3·23	12·2587*	5·49	4·0531	7·77	7·9513	18·06	9·7909	27·50	4·3334	38·58	
December	1,	56	7·4340	3·62	12·4427	7·80	4·1043	9·14	8·3730†	24·95	10·2754	36·42	4·4799	43·24	
„	4,	55·4	7·4485	3·83	12·5532	8·02	4·1348	9·94	9·5075	43·23	10·5709	47·66	4·5664	46·04	
„	7,	51·5	7·5765	5·61	12·7932	10·09	4·2778	13·75	9·8445	46·91	10·9792	42·68	4·7234	51·05	
„	11,	48·2	7·5960	5·90	12·9142	11·13	4·3108	14·62	9·9710	48·80	11·2469	46·46	4·7624	52·30	
„	13,	53·7	7·6095	6·09	12·9960	11·83	4·3288	15·10	10·0390	49·81	11·3602	47·94	4·7795	52·84	
„	15,	0·278	47·9	7·5850	5·74	13·0238	12·20	4·3049	14·47	10·1810	51·93	11·4173	48·68	4·7678	52·42
„	18,	0·265	48·5	7·6080	6·42	13·1363	13·04	4·3358	15·29	10·2680	52·33	11·5232	50·06	4·8157	53·99
„	20,	0·334	54·5	7·6475	6·61	13·2347	13·89	4·3913	16·76	10·3455	54·37	11·6314	51·47	4·8690	56·71
„	22,	0·334	54·5	7·6760	7·04	13·3227	14·65	4·4328	17·87	10·4445	55·86	11·7334	53·80	4·9789	62·23
„	29,	0·293	49·5	7·8150	8·07	13·5767	16·83	4·5678	21·19	10·6800	59·38	12·0104	56·40	5·1284	64·03
1900.															
January	4,	0·281	49·5	7·9740	11·14	13·8627	19·29	4·7268	25·69	10·9174	62·92	12·2642	59·71	5·2034	66·45
„	15,	0·319	50·0	8·2660	15·23	14·3641	23·61	5·0353	33·87	11·1450	66·32	12·6149	64·28	5·2487	67·86
„	19,	0·322	50·0	8·2800	15·41	14·4357	24·27	5·0605	34·79	11·2550	67·96	12·6229	64·38	5·1884	65·91
„	22,	0·302	52·0	8·3235	16·06	14·5264	25·04	5·1254	36·23	11·2815	68·85	12·6699	65·00	5·1984	66·10
„	26,	0·338	52·9	8·4165	17·32	14·7022	26·55	5·2343	39·16	11·3790	69·81	12·7629	66·21	5·1914	66·05
„	29,	0·255	47·5	8·4035	17·12	14·7194	26·69	5·2578	39·28	11·3390	69·21	12·7294	65·77	5·1219	63·82
February	2,	0·253	49·0	8·4105	17·27	14·7632	27·07	5·2660	40·02	11·3190	68·91	12·7276	65·52	5·0694	61·50
„	5,	0·233	47·5	8·3750	16·70	14·7532	26·99	5·2468	39·52	11·2645	68·10	12·6726	65·04	5·0094	60·21
„	9,	0·245	46·5	8·2975	15·66	14·7227	26·71	5·1893	37·94	11·1805	66·85	12·5894	64·86	4·9381	57·92
„	12,	0·216	41·5	8·2448	14·90	14·7057	26·88	5·1478	36·35	11·1232	66·02	12·7041	66·62	4·8604	55·64
„	16,	0·269	49·0	8·2475	14·95	14·7742	27·14	5·1613	37·22	11·1380	66·18	12·7604	66·38	†	
„	19,	0·269	48·25	8·2623	15·14	14·8330	27·04	5·1861	37·85	11·1520	66·42	12·7604	66·18	4·8944	56·53
„	26,	0·323	55·5	8·2715	15·29	14·9572	28·71	5·2545	39·72	11·1443	66·30	12·7149	66·33	4·9324	57·77
March	2,	0·274	51	8·2437	14·90	14·9852	28·95	5·2488	39·58	11·0765	65·15	12·6584	64·85	4·8961	56·58
„	5,	0·281	50	8·2255	14·74	15·0027	29·11	5·2343	39·18	11·0803	65·20	12·6269	64·45	4·8659	55·65
„	9,	0·274	52	8·1235	13·22	14·9569	28·71	5·1748	37·56	11·9718	63·73	12·4875	62·60	4·8034	53·69
„	12,	0·285	51·75	8·0901	12·75	14·9767	28·89	5·1611	37·22	10·9555	63·48	12·4564	62·20	4·7859	52·80
„	16,	0·282	52·25	8·0096	11·64	14·9775	28·89	5·1300	36·38	10·8730	62·26	12·3604	60·93	4·7690	52·45
„	20,	0·266	48·9	7·9022	10·14	14·9430	28·59	5·0612	34·55	10·7705	60·73	12·2774	59·87	4·7019	50·38
„	23,	0·293	51·25	7·9180	10·39	15·0082	29·13	5·0993	35·55	10·8375	61·73	12·3574	60·25	4·8374	54·69
„	26,	0·240	47·4	7·8735	9·78	14·9862	29·98	5·0713	34·82	10·8110	61·33	12·2619	59·65	4·8084	53·76
„	31,	0·328	54·0	7·7105	7·62	14·9527	28·67	4·9725	32·20	10·7070	59·72	12·1244	57·88	4·6254	47·94
April	3,	0·306	52·5	7·6578	6·82	14·9655	28·79	4·9419	31·39	10·7027	59·66	12·0931	57·46	4·6134	47·52
„	7,	0·331	48·75	7·5740	5·59	14·9807	28·91	4·8911	30·06	10·6920	59·40	12·0444	56·84	4·5935	47·00
„	10,	0·317	52·0	7·5490	5·25	15·0322	29·36	4·8908	30·05	10·7090	59·75	12·0569	57·02	4·6251	47·91
„	27,	0·349	53·75	7·4674	4·09	15·3349	31·96	5·0048	33·06	10·8037	61·22	12·1069	57·57	4·6404	48·40
May	2,	0·426	56·75	7·4265	3·52	15·3912	32·42	5·0318	33·80	10·8165	61·42	12·0893	57·41	4·6644	49·06
„	9,	0·425	61·5	7·3035	1·85	15·4033	32·55	4·9888	32·59	10·7200	59·98	11·9824	56·02	4·6179	47·78
„	16,	0·380	57·75	7·1990	0·36	15·3835	32·36	4·9043	30·41	10·5973	58·14	11·8611	54·45	4·5929	46·88

A steady increase or a fluctuation in weight of the salts is best shown under Column W'. This gives the weight of water absorbed for 100 parts of each salt, and thus shows its comparative avidity for moisture at different temperatures, and also with slight alterations in the tension of aqueous vapour. Numbers from which the formulæ for the hydrated salts were calculated are shown in Clarendon type.

\* November 27th.

† November 29th, W, 8·913.

‡ No weight recorded on February 16th.

## THE ILLUSTRATIONS.

A word of explanation is necessary with respect to the curves.

As the weighings of the salts on different occasions were carried out to a degree of accuracy, represented by one-tenth of a milligramme, and as the initial weight of the salt was represented as 100 parts, and was calculated to two decimal places, it was found that a curve to represent either of these values would have been unmanageable. Accordingly, it was decided that the ordinate numbers should represent parts per 1000 of the weight in excess of the original salt, and that the abscissæ should be the days of the month on which the weighings were made. We may thus consider zero as 1000, and the increase in weight extends up to nearly 700 in excess of this. The whole of the curve has not been given, but only the principal portions on three separate sheets. Thus the beginning of the curve is not seen, but is indicated.

To avoid complications, the temperature curves and the curves representing the tension of aqueous vapour have been omitted.

The following particulars are of interest regarding these compounds:—

*Cupric Chloride*,  $\text{CuCl}_2 \cdot 2\text{H}_2\text{O}$ .—Notwithstanding an increase in vapour pressure, a rise of temperature caused a decrease in weight as soon as the mean temperature had risen to  $52^\circ \text{F}$ ., the maximum being  $59^\circ \cdot 0$ , and the minimum  $45^\circ \cdot 5$ .

But a maximum of  $64^\circ \cdot 5$ , and a minimum of  $51^\circ$ , the pressure of aqueous vapour being 0.305 inches of mercury, the reduction in weight was almost down to the normal condition of the solid, or within 1.0 per cent. of the initial weight of the salt. In other words, not only had the salt ceased to be either deliquescent or hygroscopic, but it had also lost the water it had previously gained.

This accounts for the fact that, day after day, for many successive weeks, some of this salt, contained in a porcelain dish, was always a green liquid in the morning and a mass of blue crystals in the afternoon. It was freely exposed on a laboratory table about three feet from a window and twenty feet from a fire-stove. The temperature of the room, therefore, gradually rose, and at night sank again to a temperature at which the salt became deliquescent.

*Cupric Bromide*,  $\text{CuBr}_2$ , Anhydrous.—This is a steel-grey substance, with brilliant metallic lustre. The behaviour of the compound is singular, for it is strongly hygroscopic without being markedly deliquescent, and its hygroscopicity is to a large extent independent of temperature, provided the atmosphere is well charged with aqueous vapour. In comparison with the chloride, it shows a much greater number of fluctuations over the same range of temperature and the same conditions of humidity.

Three different conditions of hydration, and at least two different hydrates,

may be observed to be present simultaneously in the one quantity of salt, two solid hydrates and one liquid, the latter being in very small proportion to the whole mass. The solid compounds are—first, the dull coal-black dihydrate; secondly, the golden green crystals of the pentahydrate. The liquid hydrate is a brown and intensely dark solution. The course of chemical change noticed during the absorption of aqueous vapour was a swelling up of the lustrous steel-grey mass and its conversion into the porous coal-black dihydrate. There was subsequently formed an incrustation of golden green crystals of the pentahydrate, which disappeared as the temperature rose, but at points where the salt came into contact with the sides of the glass vessel drops of brown liquid were seen. These did not dry up or crystallize; neither did they change colour. It was from such a solution that only the anhydrous salt could be crystallized, at or about the temperature of 60° F.; and it certainly contains either the anhydrous salt or a compound of no higher degree of hydration than that of the dihydrate. From the curve and from the tabular statement it is clear that the most stable condition of the salt at ordinary atmospheric temperatures is that of a solution in which the total quantity of water is represented by the formula  $\text{CuBr}_2 \cdot 3\text{H}_2\text{O}$ . I have not obtained a crystallized solid compound with this composition from such a solution.

The cupric bromide was never converted quite into the pentahydrate; and as soon as a portion was changed into this compound, it became decomposed by a slight rise of temperature. As it is known from previous experiments that the pentahydrate liquefies and becomes brown under such conditions, it is only reasonable to conclude that the decomposition of the crystals results in the formation of the drops of brown liquid. But the peculiar colour and spectrum of the solution by which it is distinguished from that of the crystallized solid, and also from the fact that attempts to crystallize this solution at a temperature of 60° F., or higher than 60° F., have always resulted in the production of the anhydrous cupric bromide, I have been led to the conclusion that the pentahydrate is dissociated when simply dissolved in water. At a lower temperature, when the solution is not too concentrated, the green pentahydrate may be crystallized from the brown solution in magnificently coloured green prisms an inch in length, though the colour of the solution does not change, but remains brown.

If the solution be too concentrated, cooling even below 0° does not crystallize it, but if it be further concentrated by heat, and cooled, the anhydrous salt crystallizes out; and also, if the concentrated solution be allowed to remain in an air-pump bell-jar over oil of vitriol, the anhydrous salt separates.

*Cobalt Chloride*,  $\text{CoCl}_2 \cdot 6\text{H}_2\text{O}$ .—The fluctuations in weight began to be most marked when the maximum was 58·5° F., and the minimum 46°·0; also 56°·5 and 47°·5, respectively. There is a point of stability reached when the mean

temperature is about  $57^{\circ}75$ , even when the pressure of aqueous vapour is 0.3, or 0.4 inches of mercury.

This represents altogether  $12\text{H}_2\text{O}$ , or the increase over the initial weight of the salt is 30.4 per cent., which represents absorbed water. The salt is wholly liquid. Before this, however, there is a wavering between eight and nine molecules of water.

*Cobalt Bromide*,  $\text{CoBr}_2 \cdot 6\text{H}_2\text{O}$ .—The fluctuations occur with a maximum of  $61^{\circ}$  and a minimum of  $47^{\circ}$ , or a mean of  $54^{\circ}$ , but the difference amounts to  $\pm 0.3$  on the total weight of 159.4 grs. Thus, for instance, with a tension of aqueous vapour of 0.425, a maximum of  $63^{\circ}$ , and a minimum of  $60^{\circ}$ , equal to a mean temperature of  $61^{\circ}5$ , we obtain a total weight of 159.98 grs., or very nearly 60 per cent. over the initial weight of the salt. In these circumstances the salt is wholly liquid.

*Nickel Bromide*,  $\text{NiBr}_2 \cdot 6\text{H}_2\text{O}$ .—With a maximum temperature of  $56^{\circ}5$ , and a minimum of  $41^{\circ}3$ , equivalent to a mean of  $45^{\circ}$ , slight variations in weight occur very similar to those observed in the case of cobalt bromide, but the excess over the initial weight of the salt is 56.02 per cent. on a total of 156.02 grs. This salt is wholly liquid.

*Nickel Iodide*,  $\text{NiI}_2 \cdot 7\text{H}_2\text{O}$ .\*—This salt increased in weight more rapidly than any of the others, more especially at first, and showed no fluctuation until it became converted into a salt with 23 molecules of water.

#### THE ABSORPTION OF LIGHT BY SOLUTIONS OF HALOID SALTS OF COPPER, NICKEL, AND COBALT.

The more nearly the copper and nickel salts approach in composition the anhydrous state, it is observed that the greater is the absorption of light by the molecules. The effect of diluting the concentrated green solution of cupric chloride produces a blue colour, resembling that of the crystallized hydrate,  $\text{CuCl}_2 \cdot 2\text{H}_2\text{O}$ ; and of the brown solution of the cupric bromide, a green and afterwards a blue solution, much less absorbent for the rays of white light than the original solution. The colour of the deliquescent concentrated solution of cupric chloride is, however, still grass-green, and that of the deliquesced cupric bromide is brown. These facts, at first sight, appear to be out of harmony with the degree of hydration of the salts as determined by the weight of water absorbed in the foregoing record of experiments, but the conditions existing in the solutions must be taken into account along with the intensity of colour of the different compounds. The solution of  $\text{CuCl}_2 \cdot 2\text{H}_2\text{O}$  in a minimum of water is much darker than the solid salt, as also is the solid salt darker when very

\*For this formula, see *Sci. Trans. Roy. Dub. Soc.*, vol. vii., ser. II., 1900, p. 265.

slightly moist than when quite dry, because it is wetted with the darker solution. In the deliquesced hydrates we have mixtures of the monohydrated cupric chloride, of a very dark rich green, of the dihydrate pale blue, and of a trihydrate, with a paler blue colour, the colour of the two latter being masked by that of the first compound. Similarly, but in a much more marked degree, cupric bromide and nickel bromide change colour, the lower hydrates being much more intensely coloured than those containing more water. Nickel iodide behaves also in a similar manner.

#### CONCLUSIONS.

These observations show that the bromides are more deliquescent than chlorides, and the iodide than the bromides; also that the most stable liquid hydrates are those of nickel iodide, with 23 and 21 molecules of water, while next in order are the cobalt bromide and nickel bromide, with 18 molecules; cobalt chloride, with 11 molecules; cupric bromide, with 4 molecules; and cupric chloride, with 3 molecules of water.

This is also the case with cobalt iodide, but no figures are given here because the salt is decomposed by light. It is a substance so deliquescent that if a moist salt be placed in a bell-jar with oil of vitriol and cobalt iodide standing side by side in separate vessels, the cobalt iodide increases in weight more rapidly than the sulphuric acid. The cupric bromide was never quite converted into the pentahydrate, and as soon as a portion changed into this compound it became decomposed by a slight rise of temperature.

The chemical relationship of the absorbed water to the salt is shown by the fact that the three metals do not differ largely in atomic mass, the differences in the molecular mass of each of the salts being principally due to the atomic masses of the halogen elements, which differ widely.

It is also evident that it is not any one constituent of the salt, but the salt molecule as a whole which combines with the water. For instance:—

Formula.	Molecular Mass.	Hydrate formed.
CuCl <sub>2</sub> .	134.6.	CuCl <sub>2</sub> ·3H <sub>2</sub> O.
CuBr <sub>2</sub> .	223.6.	CuBr <sub>2</sub> ·4H <sub>2</sub> O.
CoCl <sub>2</sub> .	130.0.	CoCl <sub>2</sub> ·11H <sub>2</sub> O.
CoBr <sub>2</sub> .	219.0.	CoBr <sub>2</sub> ·18H <sub>2</sub> O.
NiBr <sub>2</sub> .	218.7.	NiBr <sub>2</sub> ·18H <sub>2</sub> O.
NiI <sub>2</sub> .	312.7.	NiI <sub>2</sub> ·23H <sub>2</sub> O.

Furthermore, that the attraction of the salt for water is independent of the molecular mass of the salt. For example, cobalt chloride absorbs more water than cupric chloride; also cobalt and nickel bromide than cupric bromide.

In other words, it is a true chemical combination, dependent for its formation on the chemical property of the whole molecule of the salt, and not upon that of any one or other of its constituents.

These results have a practical bearing on the preparation of the crystallized compounds, inasmuch as we now know the conditions under which they may be produced.

I cannot omit mentioning that the whole series of observations was made in my laboratory by Mr. J. A. Cunningham, A.R.C.S.C.I., B.A., with conscientious care and exactitude. The results were periodically checked by me, while the condition of the salts and the temperatures were almost daily under my observation.

---







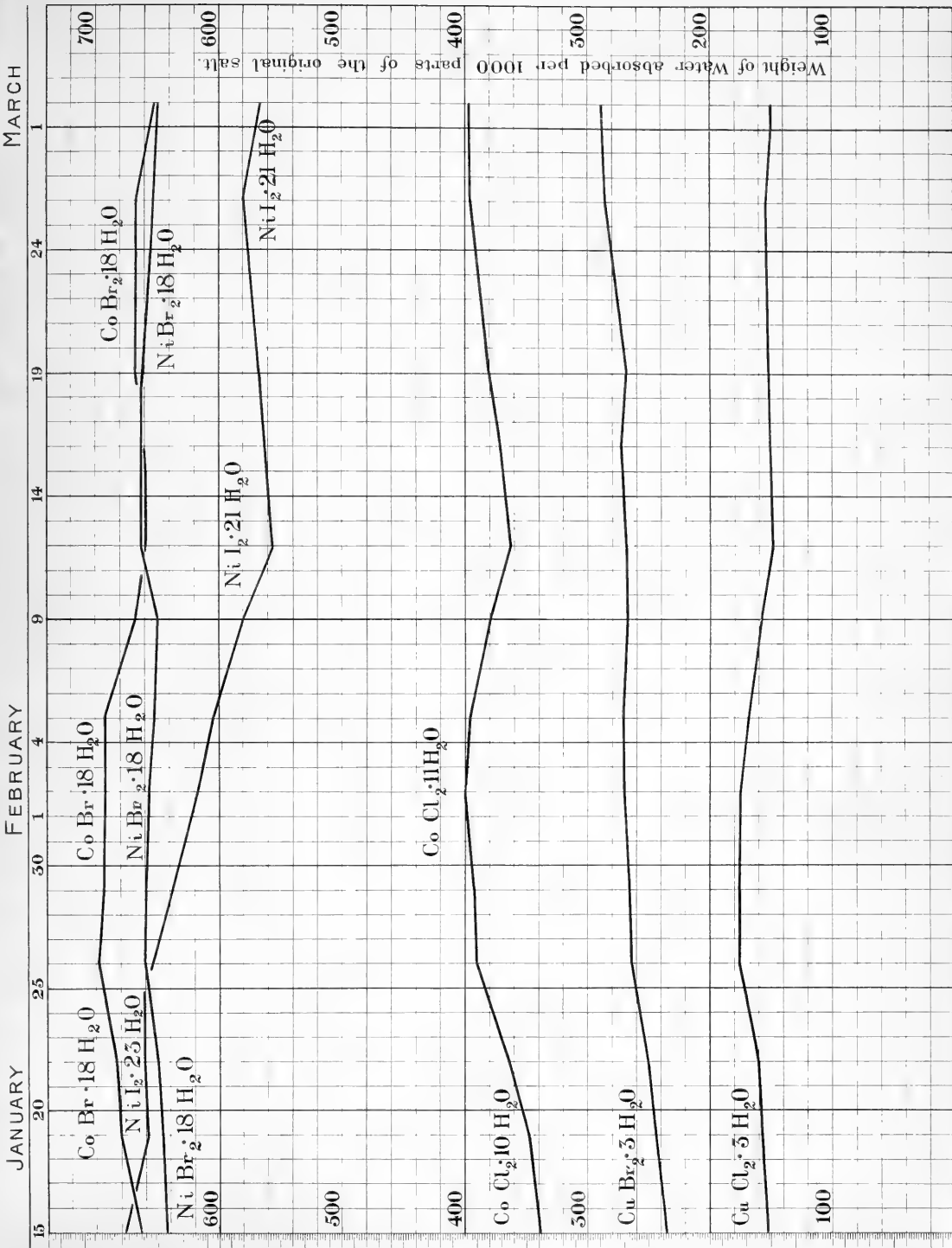



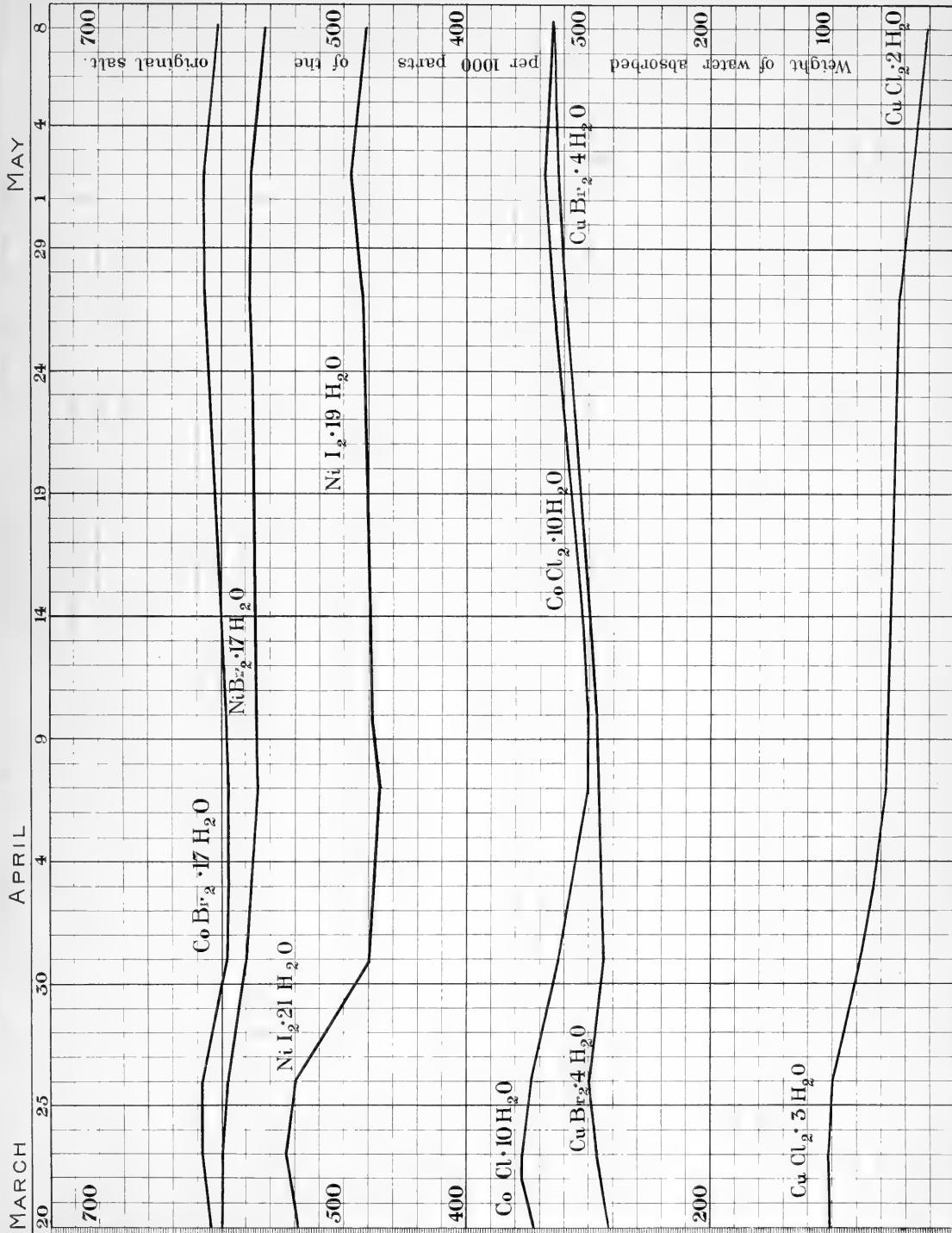





## TRANSACTIONS (SERIES II.).

---

VOL. I.—Parts 1-25.—November, 1877, to September, 1883.

VOL. II.—Parts 1-2.—August, 1879, to April, 1882.

VOL. III.—Parts 1-14.—September, 1883, to November, 1887.

VOL. IV.—Parts 1-14.—April, 1888, to November, 1892.

VOL. V.—Parts 1-13.—May, 1893, to July, 1896.

VOL. VI.—Parts 1-16.—February, 1896, to August, 1898.

---

### VOLUME VII.

PART

1. A Determination of the Wave-lengths of the Principal Lines in the Spectrum of Gallium, showing their Identity with Two Lines in the Solar Spectrum. By W. N. HARTLEY, F.R.S., and HUGH RAMAGE, A.R.C.S.C.I. Plate I. (August, 1898.) 1s.
2. Radiating Phenomena in a Strong Magnetic Field. Part II.—Magnetic Perturbations of the Spectral Lines. By THOMAS PRESTON, M.A., D.SC., F.R.S. (June, 1899.) 1s.
3. An Estimate of the Geological Age of the Earth. By J. JOLY, M.A., B.A.I., D.SC., F.R.S., F.G.S., M.R.I.A., Honorary Secretary of the Royal Dublin Society; Professor of Geology and Mineralogy in the University of Dublin. (November, 1899.) 1s. 6d.
4. On the Electrical Conductivity and Magnetic Permeability of various Alloys of Iron. By W. F. BARRETT, F.R.S.; W. BROWN, B.Sc.; R. A. HADFIELD, M. Inst. C.E. Plates II. to IX. (January, 1900.) 4s.
5. On some Novel Thermo-Electric Phenomena. By W. F. BARRETT, F.R.S., Professor of Experimental Physics in the Royal College of Science for Ireland. Plate IXA. (January, 1900.) 1s.
6. Jamaican Actiniaria. Part II.—Stichodactylinæ and Zoanthæ. By J. E. DUERDEN, Assoc. R. C. Sc. (Lond.), Curator of the Museum of the Institute of Jamaica. Plates X. to XV. (January, 1900.) 3s.
7. Survey of Fishing Grounds, West Coast of Ireland, 1890-1891. X.—Report on the Crustacea Schizopoda of Ireland. By ERNEST W. L. HOLT, and W. I. BEAUMONT, B.A., Cantab. Plate XVI. (April, 1900.) 1s. 6d.
8. The Action of Heat on the Absorption Spectra and Chemical Constitution of Saline Solutions. By W. N. HARTLEY, F.R.S., Royal College of Science, Dublin. Plates XVII. to XXI. (September, 1900.) 3s. 6d.
9. On the Conditions of Equilibrium of Deliquescent and Hygroscopic Salts of Copper, Cobalt, and Nickel, with respect to Atmospheric Moisture. By W. N. HARTLEY, F.R.S., Honorary Fellow of King's College, London; Professor of Chemistry, Royal College of Science, Dublin. Plates XXIII., XXIV., and XXV. (July, 1901.) 1s.

[August, 1901.]

THE  
SCIENTIFIC TRANSACTIONS  
OF THE  
ROYAL DUBLIN SOCIETY.

VOLUME VII.—(SERIES II.)

---

X.

A NEW COLLIMATING-TELESCOPE GUN-SIGHT FOR LARGE AND SMALL  
ORDNANCE.

By SIR HOWARD GRUBB, F.R.S., Vice-President, Royal Dublin Society.

(PLATE XXVI.)

---

DUBLIN:  
PUBLISHED BY THE ROYAL DUBLIN SOCIETY.  
WILLIAMS AND NORGATE,  
14, HENRIETTA STREET, COVENT GARDEN, LONDON;  
20, SOUTH FREDERICK STREET, EDINBURGH; AND 7, BROAD STREET, OXFORD.  
PRINTED AT THE UNIVERSITY PRESS, BY PONSONBY AND WELDRICK.

1901.

---

*Price One Shilling.*

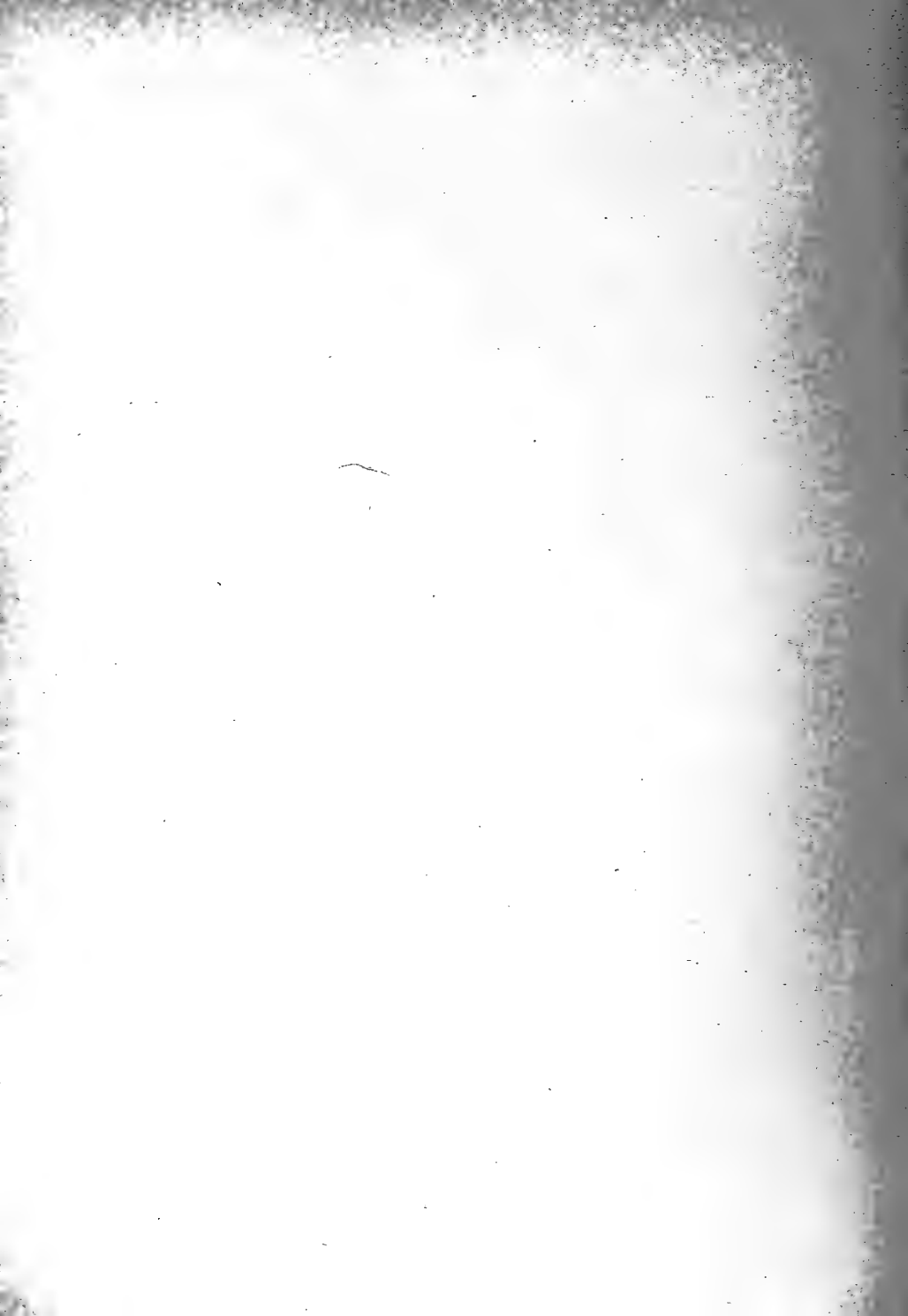



## INDEX SLIP.

---

GRUBB, SIR HOWARD.—A new Collimating-Telescope Gun-Sight for large and small Ordnance.

Roy. Dublin Soc. Trans., 2, vol. 7, 1898-1901, pp. 321-330.

Gun-Sight consisting of a collimating Telescope adaptable for large and small Ordnance.

Grubb, Sir Howard.

Roy. Dublin Soc. Trans., 2, vol. 7, 1898-1901, pp. 321-330.

INDEX SLIP

General Sir Howard - A new Collimating Telescope Gun-sight for large and small Ordnance.  
Roy. Dublin Soc. Trans. 2, vol. 7, 1838-1839, pp. 281-300.

Gun-sight consisting of a collimating Telescope adapted to large and small Ordnance.  
Grippe, Sir Howard.  
Roy. Dublin Soc. Trans. 2, vol. 7, 1838-1839, pp. 281-300.

[August, 1901.]

THE  
SCIENTIFIC TRANSACTIONS  
OF THE  
ROYAL DUBLIN SOCIETY.

VOLUME VII.—(SERIES II.)

---

X.

A NEW COLLIMATING-TELESCOPE GUN-SIGHT FOR LARGE AND SMALL  
ORDNANCE.

By SIR HOWARD GRUBB, F.R.S., Vice-President, Royal Dublin Society.

(PLATE XXVI.)

---

DUBLIN:  
PUBLISHED BY THE ROYAL DUBLIN SOCIETY.  
WILLIAMS AND NORGATE,  
14, HENRIETTA STREET, COVENT GARDEN, LONDON;  
20, SOUTH FREDERICK STREET, EDINBURGH; AND 7, BROAD STREET, OXFORD.  
PRINTED AT THE UNIVERSITY PRESS, BY PONSONBY AND WELDRICK.

1901.



## X.

A NEW COLLIMATING-TELESCOPE GUN-SIGHT FOR LARGE AND SMALL  
ORDNANCE. BY SIR HOWARD GRUBB, F.R.S., Vice-President, Royal  
Dublin Society.

(PLATE XXVI.)

[Read, MARCH 20th, 1901.]

WHEN it is necessary to point any instrument at an object, whether it be a rifle, or a gun, or a telescope, it is usual to do so by glancing at the object along the axis of the instrument, or some member or part which is parallel to the axis, bringing this part as nearly as possible into the line of sight between the eye and the object aimed at. This is done instinctively, without any education or instruction, and it is curious to note that in this, the twentieth century, the most primitive and unscientific method still endures, and is used in all but exceptional cases for sighting purposes in our most modern weapons.

It is true, of course, that for the more delicate operations involved in geodetical surveying, and in astronomical work where greater accuracy is a necessity, the telescope is used to determine the bearing or direction of objects, and of late years, the same has been applied to the directing of some of our larger ordnance; still the fact remains, that notwithstanding the ingenious and sometimes complicated refinements applied to guns of various types for the elimination of errors due to the trajectory, drift, windage, &c., the ultimate sighting, or laying of the gun in that particular direction which will cause the projectile to hit the target, is effected by this same primitive method, which, though capable of giving wonderfully good results in the hands of highly skilled and experienced marksmen, is hardly adequate for modern requirements.

Even the most cursory student in such matters cannot fail to have noticed that, as a result of the labours of successive generations of military and mechanical engineers and scientific men, modern weapons of war have been developed to an extent beyond all expectations, and yet, notwithstanding all these improvements, the survival of all that is good from the vast labour that has been expended on the subject, the ultimate operation of laying the sights of a modern gun is the same in principle and in effect as that used with the weapons of mediæval ages.

Let us consider first the principle of the ordinary sighting of a rifle, and see where the faults exist, and how they can be remedied. In the ordinary system, it is necessary for correct aiming that the eye of the observer, the object, and the fore- and back-sights of the gun, be all brought accurately into line. This can only be effected by viewing simultaneously the back-sight, fore-sight, and object superposed on one another, and centring them, so to speak, over each other with as great accuracy as is possible.

Now the human eye has wonderful power of judgment in matters of symmetry, and if it were possible to see these three objects (back-sight, fore-sight, and target) distinctly and simultaneously, there is no reason why this system should not give very fairly accurate results; but everyone knows that if we direct our attention to the distant object, in which case our eye will automatically focus itself on that object, the fore-sight will be indistinct and blurred, while if we focus our eye on the fore-sight, the object will appear indistinct, and the same reasoning applies to the back-sight, with even greater force, as it is so much closer to the eye.

The process of aiming or sighting with ordinary gun-sights, therefore, involves the centring, or matching, of three objects on each other, of which only one can ever be distinctly seen at any one time, and therefore the operation is most unsatisfactory and unscientific.

It is quite true that many possessing abnormally keen sight, and much perseverance, have done marvellous work with the present arrangements, but these are the exceptions, and that they do make excellent shooting, by no means disposes of what is said above, as to the defects of the present system.\*

It will naturally occur to the reader that the attachment of a small telescope to a gun would solve the problem. In this case, the object could be viewed simultaneously with a pair of cross lines or other device in the eye-piece, and the arrangement would be free from the defects mentioned as inherent to the old sights. There would be only two objects to match, and these could be seen simultaneously and perfectly sharply.

No doubt, with telescopic sights, any desired accuracy of aiming can be obtained, but that the ordinary telescopic sight does not meet all the requirements of the case is sufficiently evident from the fact that, although such sights have been before the public for many years, they have not to any great extent replaced

\* It is likely, so far as military interests are concerned, and more particularly so long as our army is recruited as it is at present, that the most suitable system will *not* be that which will enable a few keen-eyed men, with determined perseverance, to attain to a wonderful pitch of perfection, but, on the contrary, the more useful system will be, that which will enable the average man, with very little training, and very little practice, to shoot practically as well as the best.

the old, admittedly defective, naked-eye sights. This has been attributed to various causes:—

- (a) The limited field of view rendering it more difficult to catch up the object.
- (b) The greater apparent speed of the moving objects, owing to the magnification, and consequent difficulty of aiming at them.
- (c) The parallax errors produced by imperfect focussing, and the difficulty of providing a telescope which will keep in adjustment, notwithstanding the concussions to which it is subject. This difficulty is so serious that arrangements are generally made for removing the telescope before each explosion.
- (d) The unpleasantness, not to say the danger of keeping the eye against an eye-stop while firing the gun, and many other like reasons, probably the greatest being that, the eye being fixed to the eye-piece, one loses cognizance of everything that goes on around except what can be seen in the limited field of the telescope, and thus valuable opportunities may be lost.

If possible, there should be no obstruction to the view, so that advantage may be taken of any puff of smoke or other indication of the enemy's whereabouts.

To return, however, to the ordinary or non-telescopic sights. The difficulties consist in the matching or superposing three objects on one another, any two of which must be indistinct when the eye is focussed on the third; and of avoiding parallax due to want of precision in position of the eye.

To find some contrivance for the purpose of obviating these difficulties is the problem that presents itself.

An ideal sighting arrangement, though of course an absolutely impracticable one, might be conceived, as consisting of a ring or cross supported on an immensely long rod giving a prolongation to the gun-barrel, the rod being absolutely imponderable and perfectly stiff, so that the ring or cross would always be carried precisely in the prolongation of the axis, and every shot fired would pass through the ring. Now if the rod be only long enough to reach to the object, we have evidently merely to place this ring on the object and the shot must hit, as it must pass through the ring, and in this case there is plainly no necessity for any back-sight. But, it may be said, no such rod or beam is obtainable that would be absolutely imponderable and perfectly free from flexure. There is one exception to this, and that is a beam of light.

It would be possible to conceive an arrangement by which a fine beam of light like that from a search-light would be projected from a gun in the direction of its axis, and so adjusted as to correspond with the line of fire, so that, wherever the beam of light impinged upon an object, the shot would hit. This arrangement

would be of course equally impracticable for obvious reasons, but it is instanced to show that a beam of light has the necessary qualifications for our purposes.

Now, the sight which forms the subject of this Paper attains a similar result, not by projecting an actual spot of light or an image on the object, but by projecting, what is called in optical language, a “*virtual*” image upon it.

#### DESCRIPTION.

The original conception of this sight is represented in fig. 1. The object to be aimed at is viewed through a short piece of tube (*AB*) preferably square,

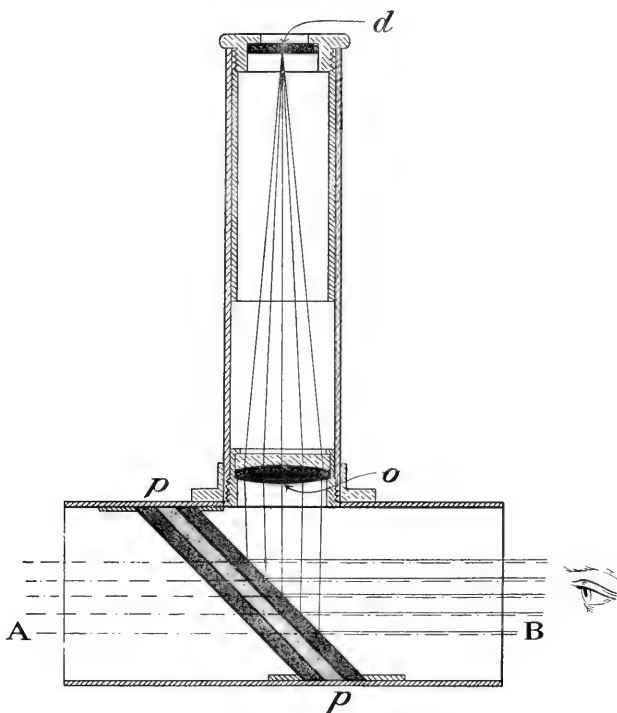

FIG. 1.

open at both ends, in which is mounted, at an angle of  $45^\circ$ , a plate or plates of parallel glass, similar to those used in sextants.



At right angles to this tube is mounted a smaller tube carrying at its outer end a diaphragm (*d*), preferably of glass coated with some opaque material, through which lines are cut representing a cross, star, circle, or any other desired device.

At the base of this same tube, near its junction with the main or sighting tube, is placed an achromatic lens, the distance between the diaphragm and the achromatic lens being equal to the principal focus of that lens; consequently rays of light from the sky or any other source of light which pass through the transparent portion of the diaphragm, diverge until they reach this object-glass (*o*), and are by it rendered parallel, and are reflected by the diagonal plate or plates, *pp*, once again as parallel rays, into the eye of the observer; the result being that the observer sees, superposed upon the object he is aiming at, an image (generally called a "virtual" image), of the cross or device cut upon the diaphragm; and inasmuch as the arrangement, when properly adjusted, is such that the rays from the diaphragm enter the eye under exactly the same conditions as if from the distant object, the cross appears not only superposed on the object, but at the same distance as the object itself. As a consequence of this, the cross is seen absolutely sharp with the same focussing of the eye as that necessary for viewing the distant object, and there is no straining of the eye to see both in focus at the same time; also it follows that there is no parallax, that is to say, that the cross and the object aimed at, if made to coincide when the eye is in the centre of the tube, will equally well coincide no matter what portion of the sighting tube the eye is placed opposite to; in other words, there is no necessity for the observer to keep his eye in any fixed position.

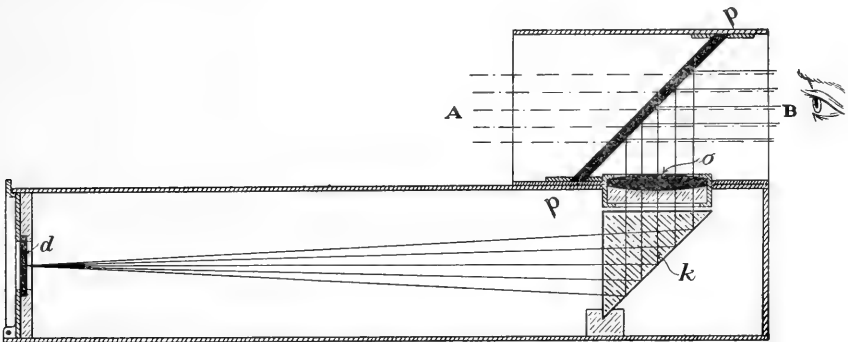

FIG. 2.

In fact this "virtual" image of the cross forms a fore-sight to the gun projected at a long distance in front of the barrel itself, as if it were carried

upon an invisible, imponderable, and inflexible prolongation of the barrel, thus obviating the necessity for any back-sight, for any motion of the eye makes no perceptible difference in the coincidence of this "virtual" image and the object. As the form of the sight above described would evidently be highly objectionable in most cases, the instrument was modified to the form shown in fig. 2, which, it will be observed, is exactly on the same principle, except that instead of mounting the collimating tube carrying the diaphragm and object-glass, at right angles to, and above, the sighting tube, this collimating tube is mounted underneath the sighting tube and parallel to it, the rays being bent by a reflector or prism, rendering the instrument of a more practical form.

It will be noticed, in both this instrument and that represented by fig. 1, that three plates of glass are shown superposed upon one another for reflecting the image of the device on the diaphragm into the eye:—The object of this is to intensify the brilliancy of the reflected image without sensibly diminishing the apparent brilliancy of the object aimed at. Later on, however, it was found that a more practical plan of increasing this brilliancy was to use one single piece of glass, and coat this with a semi-transparent and highly reflective film. A long series of experiments carried out by Professor J. Emerson Reynolds, F.R.S., and Mr. G. Rudolf Grubb, B.A.I., resulted in a modification of a process invented by the former by which the desired film was obtained.

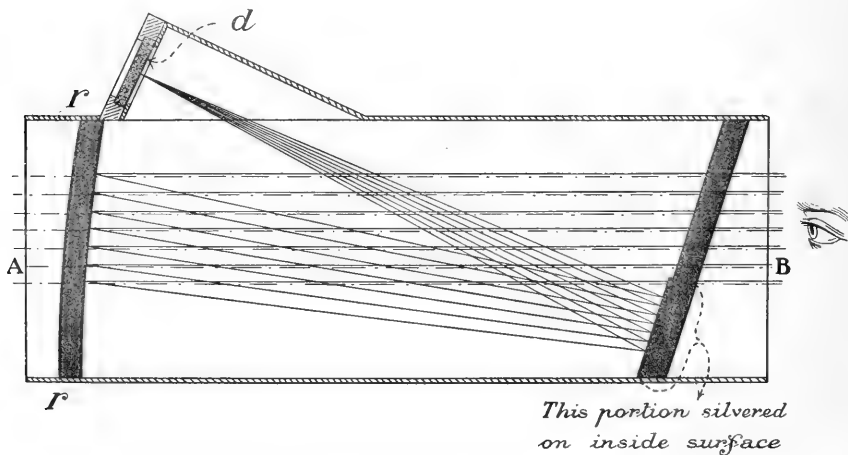

FIG. 3.

Fig. 3 shows a further modification, and the most generally favoured form of instrument at the present time, in which it will be seen that the diaphragm is

placed in a small hood or projection at the top of the sighting tube, the divergent rays from which diaphragm are reflected from the silvered portion of a piece of plane glass which also forms the back window of the sighting tube, this, being placed at a certain angle, reflects the still divergent rays on to the concave surface of the front window, and these rays are by it rendered parallel and reflected into the eye of the observer under exactly the same conditions as the rays which enter his eye from the distant object.

This front window is made concave on the inside, and convex on the outside, so that there is no magnification or diminution in the apparent size of the image, but the concave surface is coated with this reflective film, and the result is the formation of a sufficiently brilliant image of the + superposed upon the object.

In using any of these various forms of sights, the effect is best described by saying that on looking through the sight at the object, the latter is seen as through faintly smoke-tinted glass, owing to the light having to pass through the semi-transparent film, and when the eye takes up a position *anywhere near* the axis of the sight, a bright +, star, or circle, or any other device adopted, is seen superposed on the object. There is no necessity to keep the eye in any definite position so long as it is near enough to the axis to see the +; all that is necessary is to centre the + on the object, and it does not matter if, in doing this, the + be brought to the centre of the field, or sides, or corners; the aiming will be equally good, and there is the greatest possible ease and comfort in this operation. The + being as distant as the object, both are seen distinctly without any of that teasing effect due to the muscular effort in trying to focus simultaneously two objects that are at different distances.

In order to demonstrate the fact that this virtual image is formed at a long distance in front of the gun, the two illustrations, figs. 4 and 5, are reproduced here from photographs. These photographs were taken by a camera placed a few feet behind the sight.

In fig. 4, the camera was focussed on the body of the sight itself; and it will be seen that while the actual sighting tube, &c., is quite clear and sharp, the distant view is completely out of focus, and there is no cross to be seen as it also is quite out of focus.

Fig. 5 was taken from exactly the same position, the camera not having been altered in position, and under exactly the same conditions except that the lens was focussed on the distant object instead of on the body of the sight, and as will be seen, the latter is quite out of focus, but the distant object and the cross are both quite sharp and clearly defined, proving that the virtual image of the cross is formed at a considerable distance in front of the gun itself.

Among the advantages of the new sight may be enumerated:—

1. The all-important advantages of having a fore-sight at a great distance in front of the gun, and therefore seen sharply defined simultaneously with the object aimed at.
2. As a consequence of No. 1, no parallax, and therefore no necessity for any back-sight.
3. It is the only sight that can be used with or without magnifying power. The image of the + being practically at the same distance as the object aimed at, any form of telescope or field glass when in focus for the object also gives a distinct image of the +: consequently it is possible to adopt any telescope or monocular to the sight itself, or apply it in the hand at the back of the sight; or, a binocular can be used looking with one element through the sight and the other along the side of the sight. In every case a perfectly distinct image of the object with the superposed + will be seen.
4. The using of a telescope in this way as an auxiliary to the sight is not subject to all the disadvantages of the ordinary telescopic sight, as the permanence of the adjustment of the telescope itself has nothing to do with the accuracy of aiming. If the telescope be loose or out of position, it affects the apparent positions of both + and object, but not *the relative* position of one to another, and therefore permanence or rigidity in the telescope is not necessary.
5. Any form of cross or device can be used. With the ordinary telescopic sight the choice is limited to the simple + or some device that can be conveniently supported from the side of the tube. For instance it would not be possible to have a circle  $\bigcirc$  unless with cross lines thus  $\bigoplus$ , so that it could be supported in the tube.

In the new sight the device is formed by cutting lines on an opaque film deposited upon a piece of glass, so that any form of cross, circle, square, &c., can be used, or even scale and figures, can be projected on the object, and made useful for the estimation of distance, windage, &c.

6. The sight can be hermetically sealed so that no dewing on inside surfaces can occur, which often gives annoyance in ordinary telescopic sights.
7. The sight is self-contained, easily detached from the weapon, and has absolutely no adjustments, so that it is not possible to be put out of order or adjustment unless actually broken.

8. The field of view is practically unlimited as the eye need not be placed close to the rear end, and, consequently, the view of the horizon is not obstructed.
9. In the case of long-distance firing with a rifle when high elevations are required, the position of the weapon is more favourable than when using the old "long-distance" sight.
10. The cross or other device can be conveniently illuminated, and the sight used as effectively at night as in the day.

## EXPLANATION OF PLATE XXVI.

FIGS. 4 AND 5.—Two photographs taken of sight viewed from the rear, without changing the position of the camera. In fig. 4 the camera was focussed for the sight only, the distant view being so much out of focus as to be quite invisible. In fig. 5 the focussing was made on the distant view, and, as will be seen, the sight itself is quite indistinct, but the vertical image of the + is as sharp as the distant view, showing that it is formed at or near the plane of the object.

FIGS. 6 AND 7.—Photographs showing sight attached to rifle.



FIG. 4.



FIG. 5.



FIG. 6.



FIG. 7.

A NEW COLLIMATING-TELESCOPE GUN-SIGHT FOR LARGE AND SMALL ORDNANCE.

## TRANSACTIONS (SERIES II.).

---

VOL. I.—Parts 1-25.—November, 1877, to September, 1883.

VOL. II.—Parts 1-2.—August, 1879, to April, 1882.

VOL. III.—Parts 1-14.—September, 1883, to November, 1887.

VOL. IV.—Parts 1-14.—April, 1888, to November, 1892.

VOL. V.—Parts 1-13.—May, 1893, to July, 1896.

VOL. VI.—Parts 1-16.—February, 1896, to August, 1898.

---

### VOLUME VII.

PART

1. A Determination of the Wave-lengths of the Principal Lines in the Spectrum of Gallium, showing their Identity with Two Lines in the Solar Spectrum. By W. N. HARTLEY, F.R.S., and HUGH RAMAGE, A.R.C.S.C.I. Plate I. (August, 1898.) 1s.
2. Radiating Phenomena in a Strong Magnetic Field. Part II.—Magnetic Perturbations of the Spectral Lines. By THOMAS PRESTON, M.A., D.SC., F.R.S. (June, 1899.) 1s.
3. An Estimate of the Geological Age of the Earth. By J. JOLY, M.A., B.A.L., D.SC., F.R.S., F.G.S., M.R.I.A., Honorary Secretary of the Royal Dublin Society; Professor of Geology and Mineralogy in the University of Dublin. (November, 1899.) 1s. 6d.
4. On the Electrical Conductivity and Magnetic Permeability of various Alloys of Iron. By W. F. BARRETT, F.R.S.; W. BROWN, B.Sc.; R. A. HADFIELD, M. Inst. C.E. Plates II. to IX. (January, 1900.) 4s.
5. On some Novel Thermo-Electric Phenomena. By W. F. BARRETT, F.R.S., Professor of Experimental Physics in the Royal College of Science for Ireland. Plate IXA. (January, 1900.) 1s.
6. Jamaican Actinaria. Part II.—Stichodactylinæ and Zoanthææ. By J. E. DUERDEN, Assoc. R. C. Sc. (Lond.), Curator of the Museum of the Institute of Jamaica. Plates X. to XV. (January, 1900.) 3s.
7. Survey of Fishing Grounds, West Coast of Ireland, 1890-1891. X.—Report on the Crustacea Schizopoda of Ireland. By ERNEST W. L. HOLT, and W. I. BEAUMONT, B.A., Cantab. Plate XVI. (April, 1900.) 1s. 6d.
8. The Action of Heat on the Absorption Spectra and Chemical Constitution of Saline Solutions. By W. N. HARTLEY, F.R.S., Royal College of Science, Dublin. Plates XVII. to XXII. (September, 1900.) 3s. 6d.
9. On the Conditions of Equilibrium of Deliquescent and Hygroscopic Salts of Copper, Cobalt, and Nickel, with respect to Atmospheric Moisture. By W. N. HARTLEY, F.R.S., Honorary Fellow of King's College, London; Professor of Chemistry, Royal College of Science, Dublin. Plates XXIII., XXIV., and XXV. (July, 1901.) 1s.
10. A New Collimating-Telescope Gun-Sight for Large and Small Ordnance. By SIR HOWARD GRUBB, F.R.S., Vice-President, Royal Dublin Society. Plate XXVI. (August, 1901.) 1s.



[SEPTEMBER, 1901.]

THE

SCIENTIFIC TRANSACTIONS

OF THE

ROYAL DUBLIN SOCIETY.

VOLUME VII.—(SERIES II.)

---

XI.

PHOTOGRAPHS OF SPARK SPECTRA FROM THE LARGE ROWLAND SPECTROMETER IN THE ROYAL UNIVERSITY OF IRELAND. PART I. THE ULTRA-VIOLET SPARK SPECTRA OF IRON, COBALT, NICKEL, RUTHENIUM, RHODIUM, PALLADIUM, OSMIUM, IRIDIUM, PLATINUM, POTASSIUM CHROMATE, POTASSIUM PERMANGANATE, AND GOLD. BY W. E. ADENEY, D.Sc., A.R.C.Sc.I., Curator and Examiner in Chemistry in the Royal University of Ireland, Dublin.

(PLATES XXVII. AND XXVIII.)

---

DUBLIN:

PUBLISHED BY THE ROYAL DUBLIN SOCIETY.

WILLIAMS AND NORGATE,

14, HENRIETTA STREET, COVENT GARDEN, LONDON;

20, SOUTH FREDERICK STREET, EDINBURGH; AND 7, BROAD STREET, OXFORD.

PRINTED AT THE UNIVERSITY PRESS, BY PONSONBY AND WELDRICK.

1901.

---

*Price One Shilling.*



## INDEX SLIP.

---

ADENEY, W. E.—Photographs of Spark Spectra from the Large Rowland Spectrometer in the Royal University, [Dublin]. Part I. The Ultra-Violet Spark-Spectra of Iron, Cobalt, Nickel, Ruthenium, Rhodium, Palladium, Osmium, Iridium, Platinum, Potassium Chromate, Potassium Permanganate, and Gold.  
Roy. Dublin Soc. Trans., 2, vol. 7, 1898-1901, pp. 331-338.

Spectra : Photographs of Ultra-Violet Spark Spectra of Iron, Cobalt, Nickel, Ruthenium, Rhodium, Palladium, Osmium, Iridium, Platinum, Potassium Chromate, Potassium Permanganate, and Gold.  
Adeney, W. E.  
Roy. Dublin Soc. Trans., 2, vol. 7, 1898-1901, pp. 331-338.

INDEX: SHIP

INDEX: W. E.—Photographs of Spark Spectra from the Tarko Rowland Spectrometer in the Royal University, Dublin. Part I. The Ultra-Violet Spark-Spectra of Iron, Cobalt, Nickel, Ruthenium, Rhodium, Palladium, Osmium, Iridium, Platinum, Tellurium, Potassium, Barium, Strontium, Calcium, and Gold. Roy. Dublin Soc. Trans., 2, vol. 7, 1898-1901, pp. 331-338.

INDEX: W. E.—Photographs of Ultra-Violet Spark Spectra of Iron, Cobalt, Nickel, Ruthenium, Rhodium, Palladium, Osmium, Iridium, Platinum, Tellurium, Potassium, Barium, Strontium, Calcium, and Gold. Roy. Dublin Soc. Trans., 2, vol. 7, 1898-1901, pp. 331-338.

[SEPTEMBER, 1901.]

THE

SCIENTIFIC TRANSACTIONS

OF THE

ROYAL DUBLIN SOCIETY.

VOLUME VII.—(SERIES II.)

---

XI.

PHOTOGRAPHS OF SPARK SPECTRA FROM THE LARGE ROWLAND SPECTROMETER IN THE ROYAL UNIVERSITY OF IRELAND. PART I. THE ULTRA-VIOLET SPARK SPECTRA OF IRON, COBALT, NICKEL, RUTHENIUM, RHODIUM, PALLADIUM, OSMIUM, IRIDIUM, PLATINUM, POTASSIUM CHROMATE, POTASSIUM PERMANGANATE, AND GOLD. BY W. E. ADENEY, D.Sc., A.R.C.Sc.I., Curator and Examiner in Chemistry in the Royal University of Ireland, Dublin.

(PLATES XXVII. AND XXVIII.)

---

DUBLIN:

PUBLISHED BY THE ROYAL DUBLIN SOCIETY.

WILLIAMS AND NORGATE,

14, HENRIETTA STREET, COVENT GARDEN, LONDON;

20, SOUTH FREDERICK STREET, EDINBURGH; AND 7, BROAD STREET, OXFORD.

PRINTED AT THE UNIVERSITY PRESS, BY PONSONBY AND WELDRICK.

1901.



## XI.

PHOTOGRAPHS OF SPARK SPECTRA FROM THE LARGE ROWLAND SPECTROMETER IN THE ROYAL UNIVERSITY OF IRELAND. PART I. THE ULTRA-VIOLET SPARK SPECTRA OF IRON, COBALT, NICKEL, RUTHENIUM, RHODIUM, PALLADIUM, OSMIUM, IRIDIUM, PLATINUM, POTASSIUM CHROMATE, POTASSIUM PERMANGANATE, AND GOLD. BY W. E. ADENEY, D.Sc., A.R.C.Sc.I., Curator and Examiner in Chemistry in the Royal University of Ireland, Dublin.

(PLATES XXVII. and XXVIII.)

[Read APRIL 17, 1901.]

### Introduction.

PECULIARITIES in the constitution of spark spectra of the elements were first described in the Scientific Transactions of this Society.\*

The photographs were taken with the first spectrograph constructed, which admitted of the whole of the spectra being included on one plate and extending from wave-lengths 4700 to 2000. The method of photographing, and the construction of the instrument, were described in a paper published by this Society.†

In "Notes on certain Photographs of the Ultra-Violet Spectra of Elementary Bodies,"‡ it was shown that when the elements were classified along with their spectra in well-defined groups, according to the periodic law, there were marked characteristics which were shown to belong to distinctive groups of the elements. These peculiar characteristics of the lines were length and continuity from pole to pole, with emissive power of intensity of chemical action, extension above and below the points of the electrodes, the nimbus or aureole, sharpness or diffuseness, and the background of continuous rays. The features of the lines were correlated with the chemical and physical properties of the elements, such as conductivity,

\* Hartley, vol. i., p. 231, 1881.

† Sci. Proc. Roy. Dublin Soc., vol. iii., ser. 2, p. 93, 1881 (Hartley).

‡ Journ. Chem. Soc., vol. xliii., p. 384, 1882 (Hartley), and "On Homologous Spectra" (*loc. cit.*, vol. xliii., p. 390, 1883, by the same author).

volatility, and oxidisability, and consequently they were correlated with the periodic law.\* A community of characteristics in spectra was recognised as being due to a similarity in the properties of the elements belonging to the same group.

It was further shown that elements with properties in common likewise exhibit spectra with similar groupings of lines; but the dispersion of the lines and the refrangibility of the strong lines in each group vary with the atomic mass of the elements.

Other observers had noted the significance of the constitution of spectra, as for instance Lecocq de Boisbaudran† and Ciamician.‡

Liveing and Dewar§, at or about the same period, also noticed the similarity in the constitution of the spectra of some metallic elements.

A study of the facts observed|| led to the conclusion that groups of elements which exhibit homologous spectra, are composed of the same kind of matter in different states of condensation, the molecules having similar modes but different rates of vibration.

Ames thought there were difficulties in drawing inferences from spark spectra, but proved the complete homology of the zinc and cadmium arc spectra.¶

Rydberg recognised the law independently in 1885.\*\*

Kayser and Runge first completely studied the subject. The formulæ which they have found for the spectra of certain groups, of which the atomic mass of the elements is a function, show that the molecules of these elements vibrate according to a general law. Their work is well known, and is of an exhaustive character, being contained in a series of seven long memoirs, which are standard works of reference.††

In determining the wave-lengths of the spark spectra of the elements, in collaboration with Professor Hartley, a small Rutherford plane grating was employed, and it was found that many of the marked features of the lines in the different spectra appeared with but little alteration, but only a small portion of each

\* "On Physical Characters of the Lines in the Spark Spectra of the Elements," Proc. Roy. Soc., vol. xlix., p. 448, 1891 (Hartley).

† "Spectres Lumineux," and Wurtz, "Dictionnaire de Chimie," new supplement, p. 859.

‡ Sitzungsberichte der K. Akademie (Wien), vol. lxxvi., p. 499.

§ Proc. Royal Institution, March 9, 1883.

|| *Loc. cit.*

¶ Phil. Mag., vol. xxx., p. 33, 1890.

\*\* Kongl. Svenska Vetenskaps-Akademiens Handlingar, Stockholm, vol. xxiii., No. 4, 1890.

†† Königl. Akademie der Wissenschaften. "Über die Spectren der Elemente." 1889 to 1893.



spectrum could be focussed on each plate, and hence any general resemblance between the spectra of similar elements was not rendered obvious.\*

The ultra-violet spectra obtained with the quartz spectrograph, while showing the differences in the lines, gave a dispersion in the ultra-violet region which was sufficient for all practical purposes. So important were the characteristics of the lines considered to be that a large amount of labour was expended in giving a minute description to each one of them, as well as their positions and wave-length measurements.

The only other observers who had given particular descriptions of the lines previously, and those only in the visible spectrum, were Thalén and Lecocq de Boisbaudran.

Photographs of spectra render any detailed descriptions of the lines now unnecessary, but attention may be directed to the fact that methods of producing spark spectra latterly employed fail to render the characteristic features of several well-marked groups of elements.

Other investigators have since published photographs of spark spectra, namely, Crew and Tatnall,† and F. McClean, M.A.‡ (these range from D to H only), and Eder and Valenta.§ In the first-mentioned memoir a table of corrections is given for converting Hartley and Adeney's measurements from Ångström's to Rowland's scale. Eder and Valenta's beautiful reproductions of spectra show that many of the features previously preserved are wanting in theirs. The same remark may be applied also to Exner and Haschek's photographs of the spark spectra of the elements. In both series the mode of producing the sparks differed from that which had been previously commonly resorted to, and concave gratings were employed.

It would be a remarkable fact if the measurements published in 1884 did not require revision for purposes of physical research, since at that period the properties of Rowland's concave gratings, which had so largely increased the accuracy of spectroscopic work, had not been discovered.

Fifteen of the spectra were entirely new to science, and the wave-lengths assigned to the lines have for all practical purposes been proved sufficiently accurate and of great utility in chemical investigations of a diverse character.

In view of the attention now being given, not only to the numerical relation-

\* Phil. Trans., vol. clxxxv., p. 63, 1884.

† Phil. Mag. (5), vol. xxxviii., p. 379, 1894.

‡ "Comparative Photographic Spectra of the Sun and the Metals." Monthly Notices of the Roy. Astron. Soc., vol. lii., No. 1.

§ "Beiträge zur Spectralanalyse," K. Akademie der Wissenschaften (Wien), 1892 to 1899.

ships of the component lines of spectra, but also to the modes of vibration of the matter, which is the cause of such radiations, the evidence of such molecular movements being the phenomena exhibited when the lines are under powerful magnetic stress, it is clearly of importance that published reproductions of photographed spectra should show any characteristics of the component rays as well as the constitution of the spectra generally. In confirmation of this statement it may be remarked that the late Dr. Preston, F.R.U.I., F.R.S., found the photographed spectra, which form the subject of this communication, and others belonging to the same collection, of great assistance in his important work upon the influence of a strong magnetic field upon radiating matter. It is desirable, therefore, that prism spectra should be compared with grating spectra, obtained in the same manner from the same elements, and attention may be directed to the reproductions of prism spectra of iron, nickel, cobalt, and gold.\* Platinum was first published in the Journal of the Chemical Society in 1882.†

The production of powerful sparks by means of dynamos, producing alternating currents, has been one of the causes of the variation in the character of spark spectra, as for instance in the work of Liveing and Dewar, Trowbridge and Sabine, Kayser and Runge, Eder and Valenta, and by the use of special forms of induction coils by Eugene Demarçay de Gramont, also Exner and Haschek. The last named workers used a current transformer combined with a coil, such as is suitable for Tesla's experiments.

#### *The Occurrence of Air-lines in Spark Spectra.*

The method of photographing the spectra of metals without the usually accompanying spectrum of air, which has been particularly described by Hemsalach,‡ also gets rid of the short lines and dots observed in many spectra, for instance in that of zinc. The process of self-induction, which is very simple, apparently lowers the temperature of the spark, and the spectra then more nearly approach the character of those obtained by the arc.

As these photographs were taken before the method of Hemsalach was published, it was impossible to employ it; it is advisable, however, to state that the air lines serve to definitely fix the positions of neighbouring lines of other elements, and in certain parts of the spectrum they prove to be a great convenience.

Numerous observations have also shown that, no matter how dense the spectrum

\* Sci. Trans. Roy. Dublin Soc., vol. i., ser. 2, p. 231, 1882.

† Journ. Chem. Soc., vol. xli., p. 84.

‡ Comptes Rendus, vol. cxxix., p. 285, 1899.

of air may be, the lines and bands of oxygen and nitrogen do not obscure or suppress those of the elements which constitute the electrodes. The stream of vapour of greater density than air fills up the track of the spark and excludes the gases of the atmosphere.

In such cases the electrodes give an imperfect air spectrum, and such imperfections are characteristic of certain metals. In measuring air lines some of the metals were found to be more suitable than others. Metallic lines also suppress neighbouring air lines, and owing to their greater emissive power are easily distinguished.

#### *Experimental Details.*

The present series of spectra form a continuation of the work above quoted. They have been photographed from the Rowland's concave grating, which has recently been mounted in the Royal University, Dublin. The grating has a focal length of 21.5 feet, and a ruled space of six inches, with 14,438 lines to the inch.

The mounting of the spectrometer in the Royal University has already been described by the author, in conjunction with Mr. J. Carson, A.R.C.S.I., in the Scientific Proceedings of the Royal Dublin Society, 1898.\*

A current of ten amperes, and a ten-inch coil by Apps, were employed, with a condenser 144 square inches in area, for "sparking."

The specimens of the metals used as electrodes were, it is believed, of a high degree of purity.

The specimen of iron was prepared from pure crystallized potassium ferrocyanide in the same manner as that employed in the investigation by Hartley of the oxyhydrogen flame spectra†; also of the arc spectra by Hartley and Ramage, for comparison with the solar spectrum when measuring the lines of gallium.‡

The specimens of cobalt and nickel were portions of those prepared by Dr. W. J. Russell, F.R.S., in his researches upon the atomic weights of those metals.

Specimens of ruthenium, rhodium, palladium, osmium, iridium, and platinum were very kindly presented by Messrs. Matthey and Johnson for the purpose of this research.

The chromium spectrum was obtained by sparking a saturated solution of potassium chromate between platinum electrodes.

\* See also *Phil. Mag.*, vol. xlvii, p. 223, 1898.

† *Phil. Trans.*, vol. clxxxv., p. 161, 1894.

‡ *Sci. Trans. Roy. Dublin Soc.*, vol. vii., ser. 2, 1898.

The manganese spectrum by sparking a saturated solution of potassium permanganate in a similar manner.

The electrodes used with such solutions were made of six plates of ordinary stout platinum foil, placed close together and fused into one end of a glass tube. The glass tube containing the solution and carrying the lower electrode was of a U shape, the open end being prolonged sufficiently above the closed end, to act as a reservoir for the liquid, and to exert a slight pressure upon the electrode so as to keep it fed continuously. The glass tube carrying the upper electrode was straight, and was also filled with the solution. With a little experience, electrodes of this form may be made to feed solutions of different strengths perfectly.

The advantage of platinum electrodes over pure graphite ones lies in the fact that during the necessarily long exposures they do not become shorter by combustion or disintegration of the material.

The specimen of gold was obtained from crystallized gold chloride, by precipitation with pure oxalic acid, washing and redissolving in aqua regia, and again precipitating with oxalic acid. The precipitated gold was finally fused under borax in a clay crucible.

The original photographs were taken from the first order of spectra; and the reproductions published with this communication are of the same size as the originals. The definition of the lines of this order is extremely fine, and the dispersion quite sufficient for most practical purposes. For these reasons it has been deemed inexpedient to have enlarged reproductions prepared for publication.

A further most important feature of this order is that the lines are the least distorted by the astigmatism of the grating, so little indeed that the characteristics of the component lines are quite apparent from the photographs, and the general character of the spectra are wholly unaffected. By the characteristics of the component lines is meant their peculiar features as observed in prism spectra, that is to say, whether extended or not, continuous or discontinuous, well defined or nebulous.

On comparing these photographs with those obtained by Eder and Valenta, and also with those of Exner and Haschek, important differences are to be observed; many lines photographed by those observers are absent; differences are also occasionally observable in the character of the lines.

Some of these differences are possibly due to a greater degree of purity in the elements and compounds examined, but the majority, however, are certainly to be ascribed to the different methods of sparking employed by the several observers.

Attention may be drawn to the marked effect which the sparking of the solutions of potassium chromate and permanganate between platinum electrodes has upon the character of some of the lines of platinum.

Careful measurements of the wave-lengths of the lines in the photographed

spectra are in preparation, but it has been thought inadvisable to delay the publication of reproductions of the spectra until the measurements are completed, both on account of the differences in number and character of the lines above referred to, and also on account of the very clear way in which the characters of the spectra and of their component lines are shown therein.

Scales of wave-lengths, based upon Kayser and Runge's measurements of the iron lines, have been ruled on the original photographs, by means of which the lines in the spectra may easily be identified, or otherwise, with measurements which have already been published in various tables of wave-lengths.

Each scale division is equal to five units on Rowland's scale; the division of all the scales are very nearly of equal magnitude in linear measurement. They have been ruled in two portions corresponding to the two sections in which the spectra had been photographed. The division on the less refrangible sections are each approximately equal to  $\cdot 0944$  inch, and those on the more refrangible sections to  $\cdot 0943$  inch.

A vernier has been ruled for each section, by means of which the wave-lengths of the lines may be approximately read off to  $0\cdot 25$  of a unit.

The errors of the scales of each spectrum are approximately given in the following table:—

LESS REFRACTIBLE SECTION.

SPECTRA.	WAVE-LENGTHS.					
	4500 to 4300	4300 to 4100	4100 to 3900	3900 to 3700	3700 to 3500	3500 to 3300
Ru, Mn (Pt & K), . . .	0·00	- 0·05	- 0·10	- 0·15	- 0·20	- 0·25
Ni & Au, . . . . .	+ 0·15	+ 0·10	+ 0·05	+ 0·00	- 0·05	- 0·10
Fe, Rh, Pd, Os, Ir, . . .						
Pt, Cr (Pt & K), . . .	+ 0·30	+ 0·25	+ 0·20	+ 0·15	+ 0·10	+ 0·05
Co, . . . . .	+ 0·45	+ 0·40	+ 0·35	+ 0·30	+ 0·25	+ 0·20

MORE REFRACTIBLE SECTION.

SPECTRA.	WAVE-LENGTHS.					
	3400 to 3200	3200 to 3000	3000 to 2800	2800 to 2600	2600 to 2400	2400 to 2200
Pd, Cr (Pt & K), Au, . . .	0·0	- 0·1	- 0·2	- 0·3	- 0·4	- 0·5
Fe, Rh, Pt, Mn (Pt & K), . . .	+ 0·2	+ 0·1	0·0	- 0·1	- 0·2	- 0·3
Os, . . . . .	- 0·2	- 0·3	- 0·4	- 0·5	- 0·6	- 0·7
Co, . . . . .	- 0·3	- 0·4	- 0·5	- 0·6	- 0·7	- 0·8
Ir, . . . . .	- 0·5	- 0·6	- 0·7	- 0·8	- 0·9	- 1·0
Ni & Ru, . . . . .	- 0·7	- 0·8	- 0·9	- 1·0	- 1·1	- 1·2

In conclusion, the author begs to express his sincere thanks to Professor W. N. Hartley, F.R.S., for much advice and assistance kindly afforded by him in the preparation of this communication. The author is also indebted to Professor Hartley for the electrodes of iron, nickel, and cobalt employed in this research, and also for allowing him free access to his private collections of spectra and instruments.

ULTRA-VIOLET SPARK SPECTRA FROM THE ROWLAND'S SPECTROMETER IN THE ROYAL UNIVERSITY OF IRELAND,

(FIRST ORDER UNENLARGED)

By W. E. Adeney, D. Sc.

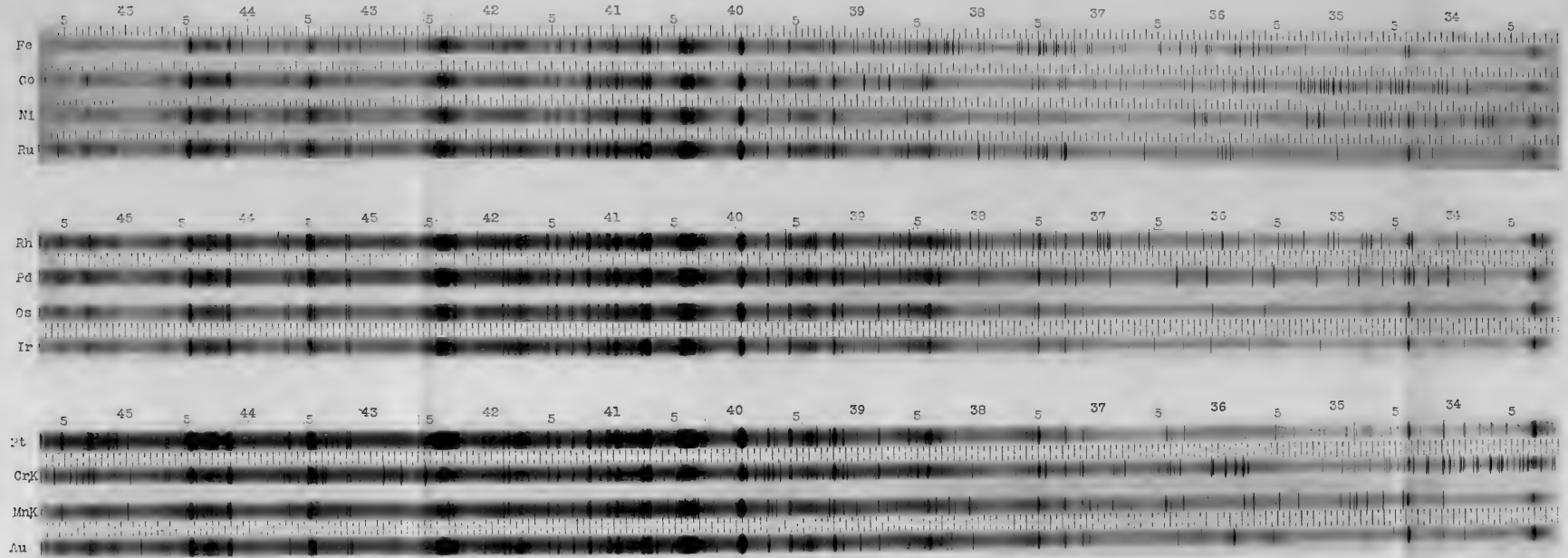

vernier [|||||]

ULTRA-VIOLET SPARK SPECTRA FROM THE ROWLAND'S SPECTROMETER IN THE ROYAL UNIVERSITY OF IRELAND.

(FIRST ORDER UNENLARGED.)

By W. E. Adeney, D. Sc.

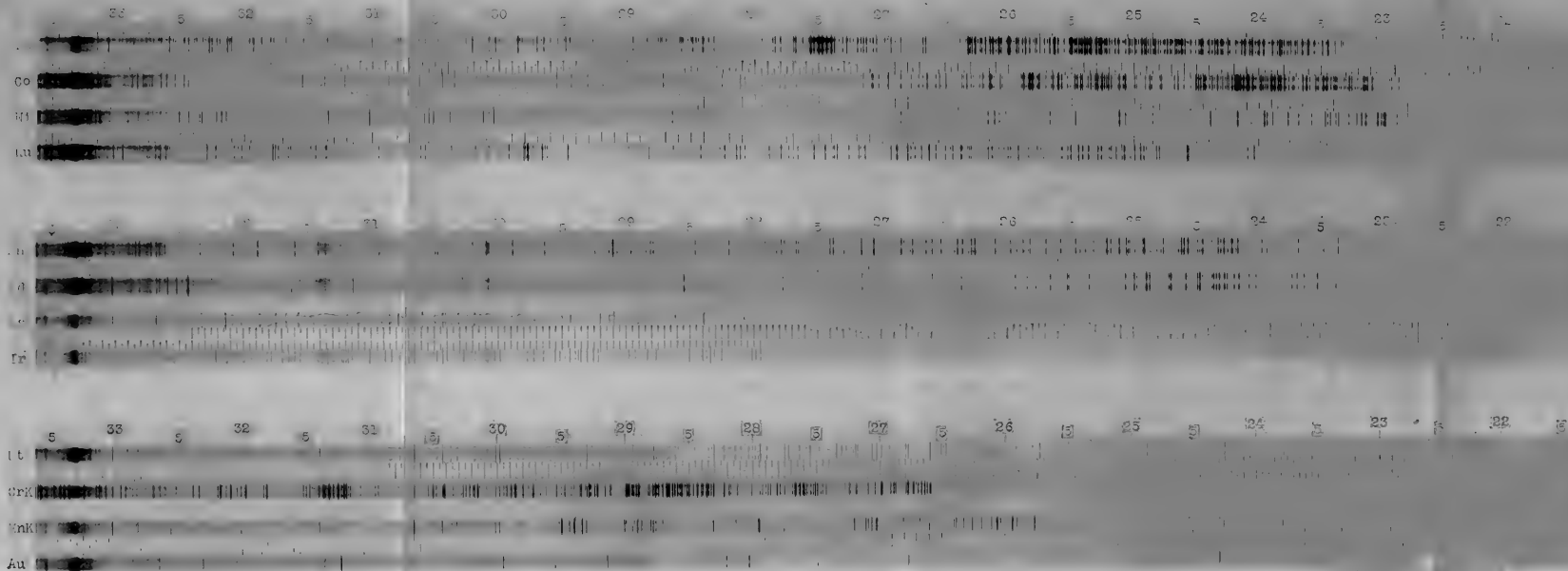





## TRANSACTIONS (SERIES II.).

VOL. I.—Parts 1-25.—November, 1877, to September, 1883.

VOL. II.—Parts 1-2.—August, 1879, to April, 1882.

VOL. III.—Parts 1-14.—September, 1883, to November, 1887.

VOL. IV.—Parts 1-14.—April, 1888, to November, 1892.

VOL. V.—Parts 1-13.—May, 1893, to July, 1896.

VOL. VI.—Parts 1-16.—February, 1896, to August, 1898.

### VOLUME VII.

PART

1. A Determination of the Wave-lengths of the Principal Lines in the Spectrum of Gallium, showing their Identity with Two Lines in the Solar Spectrum. By W. N. HARTLEY, F.R.S., and HUGH RAMAGE, A.R.C.Sc.I. Plate I. (August, 1898.) 1s.
2. Radiating Phenomena in a Strong Magnetic Field. Part II.—Magnetic Perturbations of the Spectral Lines. By THOMAS PRESTON, M.A., D.Sc., F.R.S. (June, 1899.) 1s.
3. An Estimate of the Geological Age of the Earth. By J. JOLY, M.A., B.A.I., D.Sc., F.R.S., F.G.S., M.R.I.A., Honorary Secretary of the Royal Dublin Society; Professor of Geology and Mineralogy in the University of Dublin. (November, 1899.) 1s. 6d.
4. On the Electrical Conductivity and Magnetic Permeability of various Alloys of Iron. By W. F. BARRETT, F.R.S.; W. BROWN, B.Sc.; R. A. HADFIELD, M. Inst. C.E. Plates II. to IX. (January, 1900.) 4s.
5. On some Novel Thermo-Electric Phenomena. By W. F. BARRETT, F.R.S., Professor of Experimental Physics in the Royal College of Science for Ireland. Plate IXA. (January, 1900.) 1s.
6. Jamaican Actiniaria. Part II.—Stichodactylinæ and Zoantheæ. By J. E. DUERDEN, Assoc. R. C. Sc. (Lond.), Curator of the Museum of the Institute of Jamaica. Plates X. to XV. (January, 1900.) 3s.
7. Survey of Fishing Grounds, West Coast of Ireland, 1890-1891. X.—Report on the Crustacea Schizopoda of Ireland. By ERNEST W. L. HOLT, and W. I. BEAUMONT, B.A., Cantab. Plate XVI. (April, 1900.) 1s. 6d.
8. The Action of Heat on the Absorption Spectra and Chemical Constitution of Saline Solutions. By W. N. HARTLEY, F.R.S., Royal College of Science, Dublin. Plates XVII. to XXII. (September, 1900.) 3s. 6d.
9. On the Conditions of Equilibrium of Deliquescent and Hygroscopic Salts of Copper, Cobalt, and Nickel, with respect to Atmospheric Moisture. By W. N. HARTLEY, F.R.S., Honorary Fellow of King's College, London; Professor of Chemistry, Royal College of Science, Dublin. Plates XXIII., XXIV., and XXV. (July, 1901.) 1s.
10. A New Collimating-Telescope Gun-Sight for Large and Small Ordnance. By SIR HOWARD GRUBB, F.R.S., Vice-President, Royal Dublin Society. Plate XXVI. (August, 1901.) 1s.
11. Photographs of Spark Spectra from the Large Rowland Spectrometer in the Royal University of Ireland. Part I. The Ultra-Violet Spark Spectra of Iron, Cobalt, Nickel, Ruthenium, Rhodium, Palladium, Osmium, Iridium, Platinum, Potassium Chromate, Potassium Permanganate, and Gold. By W. E. ADENEY, D.Sc., A.R.C.Sc.I., Curator and Examiner in Chemistry in the Royal University of Ireland, Dublin. Plates XXVII. and XXVIII. (September, 1901.) 1s.

[OCTOBER, 1901.]

THE  
SCIENTIFIC TRANSACTIONS  
OF THE  
ROYAL DUBLIN SOCIETY.

VOLUME VII.—(SERIES II.)

---

XII.

BANDED FLAME-SPECTRA OF METALS.

BY

W. N. HARTLEY, F.R.S.,

Honorary Fellow of King's College, London; Royal College of Science, Dublin;

AND

HUGH RAMAGE, B.A., A.R.C.Sc.I.,

St. John's College, Cambridge.

(PLATES XXIX. TO XXXIII.)

---

DUBLIN:  
PUBLISHED BY THE ROYAL DUBLIN SOCIETY.  
WILLIAMS AND NORGATE,  
14, HENRIETTA STREET, COVENT GARDEN, LONDON;  
20, SOUTH FREDERICK STREET, EDINBURGH; AND 7, BROAD STREET, OXFORD.  
PRINTED AT THE UNIVERSITY PRESS, BY PONSONBY AND WELDRICK.  
1901.

---

*Price One Shilling.*



## INDEX SLIP.

---

HARTLEY, W. N. and RAMAGE, Hugh—Banded Flame-Spectra of Metals.  
Roy. Dublin Soc. Trans., 2, vol. 7, 1898-1901, pp. 339-352.

RAMAGE, Hugh, and HARTLEY, W. N.—Banded Flame-Spectra of Metals.  
Roy. Dublin Soc. Trans., 2, vol. 7, 1898-1901, pp. 339-352.

Banded Spectra with Lines of Nickel, Cobalt, Rhodium, and Iridium.  
Hartley, W. N. and Ramage, Hugh.  
Roy. Dublin. Soc. Trans., 2, vol. 7, 1898-1901, pp. 339-352.

Flutings in Flame-Spectra of Metals.  
Hartley, W. N., and Ramage, Hugh.  
Roy. Dublin Soc. Trans., 2, vol. 7, 1898-1901, pp. 339-352.

Line Spectra to Banded Spectra, note on the Relation of.  
Hartley, W. N., and Ramage, Hugh.  
Roy. Dublin Soc. Trans., 2, vol. 7, 1898-1901, pp. 339-352.

Low emissive Power of the radiant Molecules of certain Elements.  
Ramage, Hugh, and Hartley, W. N.  
Roy. Dublin Soc. Trans., 2, vol. 7, 1898-1901, pp. 339-352.

Periodic Law and Banded Spectra, connection between.  
Hartley, W. N., and Ramage, Hugh.  
Roy. Dublin Soc. Trans., 2, vol. 7, 1898-1901, pp. 339-352.

## INDEX SHEET

HARTLEY, W. N. and RAMAGE, HUGH.—Banded Flame-Spectra of Metals.  
Roy. Dublin Soc. Trans., 2, vol. 7, 1898-1901, pp. 329-357.

RAMAGE, HUGH, and HARTLEY, W. N.—Banded Flame-Spectra of Metals.  
Roy. Dublin Soc. Trans., 2, vol. 7, 1898-1901, pp. 329-357.

Banded Spectra with Lines of Nickel, Cobalt, Rhodium, and Iridium.  
HARTLEY, W. N. and RAMAGE, HUGH.  
Roy. Dublin Soc. Trans., 2, vol. 7, 1898-1901, pp. 329-357.

Fluorescence in Flame-Spectra of Metals.  
HARTLEY, W. N. and RAMAGE, HUGH.  
Roy. Dublin Soc. Trans., 2, vol. 7, 1898-1901, pp. 329-357.

Line Spectra to Banded Spectra: note on the Relation of  
HARTLEY, W. N. and RAMAGE, HUGH.  
Roy. Dublin Soc. Trans., 2, vol. 7, 1898-1901, pp. 329-357.

Low emissive Power of the radiant Molecules of certain Elements.  
RAMAGE, HUGH, and HARTLEY, W. N.  
Roy. Dublin Soc. Trans., 2, vol. 7, 1898-1901, pp. 329-357.

Periodic Law and Banded Spectra: connection between  
HARTLEY, W. N. and RAMAGE, HUGH.  
Roy. Dublin Soc. Trans., 2, vol. 7, 1898-1901, pp. 329-357.

[OCTOBER, 1901.]

THE  
SCIENTIFIC TRANSACTIONS  
OF THE  
ROYAL DUBLIN SOCIETY.

VOLUME VII.—(SERIES II.)

---

XII.

BANDED FLAME-SPECTRA OF METALS.

BY

W. N. HARTLEY, F.R.S.,

Honorary Fellow of King's College, London; Royal College of Science, Dublin;

AND

HUGH RAMAGE, B.A., A.R.C.Sc.I.,

St. John's College, Cambridge.

(PLATES XXIX. TO XXXIII.)

---

DUBLIN:  
PUBLISHED BY THE ROYAL DUBLIN SOCIETY.  
WILLIAMS AND NORGATE.  
14, HENRIETTA STREET, COVENT GARDEN, LONDON;  
20, SOUTH FREDERICK STREET, EDINBURGH: AND 7, BROAD STREET, OXFORD.  
PRINTED AT THE UNIVERSITY PRESS, BY PONSONBY AND WELDRICK.  
1901.

ERRATUM.

Page 352, line 8 from bottom, *for* 3000 *read* 3300.



## XII.

BANDED FLAME-SPECTRA OF METALS. BY W. N. HARTLEY, F.R.S., Honorary Fellow of King's College, London; Royal College of Science, Dublin; and HUGH RAMAGE, B.A., A.R.C.Sc.I., St. John's College, Cambridge.

(PLATES XXIX.-XXXIII.)

[Read MAY 22ND, 1901.]

IN "Flame-Spectra at High Temperatures,"\* it was proved by one of the authors that metals easily volatilised exhibit banded spectra.

Characteristic flame spectra of elements were described as follows † :—

"*Band Spectra*—Antimony, bismuth, gold, tin, sulphur, selenium."

"*Band Spectra with Lines*—Copper, iron, manganese, tellurium, lead, and silver."

In addition to these the "Spectra peculiar to Compounds," such as calcium oxide, calcium fluoride, and magnesium oxide, were described as containing lines and bands.‡ A summary of similar work previously published, giving a few instances of bands in metallic spectra, was included in the paper and appendix.

It is stated on pp. 166–7 that the band-spectra of silver and gold are really due to the metals, "since no oxides of these metals can exist at the temperature of the flame employed." Reasons are also given for attributing the bands in the flame-spectra of manganese and of its compounds to the metal itself. The relation of line-spectra to band-spectra is also discussed on p. 167. The two other papers, entitled Parts II. and III. of "Flame-Spectra at High Temperatures," were published also in the same volume.

The continued investigation of this subject has been jointly prosecuted for the last six years by the authors of this communication. Photographs of the spectra have been taken with a four-prism spectrograph.§ This instrument gives wider dispersion and better definition than the one-prism instrument used in the earlier part of the investigation. By this means, and by small but important improvements in the method of working, finer detail has been obtained, new band-spectra have been discovered, and some of the bands which had been previously photographed have now been resolved so as to clearly show their component lines.

The spectrum of silver, which has already been completely described in the first paper above-mentioned, is remarkable for the character of the banded spectrum

\* Phil. Trans., vol. 185 (A.), 1894, pp. 161–212.

† See p. 166.

‡ See p. 168.

§ Phil. Trans., vol. 185 (A.), 1894, p. 1047.

which accompanies the two strong lines which are common to flame and spark spectra. The bands are apparently of two kinds: those in the visible spectrum are of the nature of flutings, but those in the ultra-violet are groups of distinct lines. The intervals between the component lines are smaller as they approach the stronger edge of the band which is situated at the more refrangible end of the spectrum. The flutings in the visible spectrum have not hitherto been resolved into lines by the instrument at our command, and undoubtedly will require a much higher dispersion.

We have found that the flame-spectra of copper and gold are even more beautiful than that of silver: the lines forming the bands are sharper and more widely separated than in the spectrum of silver, and the bands of this character are more numerous. The spectra of copper and gold have a much closer similarity in constitution than that of silver to either of them, but the complete details of these spectra have not yet been quite fully examined. In the three spectra there is this character in common, all the bands are degraded towards the red.

#### BANDED FLAME-SPECTRA OF COPPER, SILVER, AND GOLD.

##### *Measurements of the Edges of the Bands.*

COPPER.		SILVER.		GOLD.	
Wave-lengths.	Intensity of Band.	Wave-lengths.	Intensity of Band.	Wave-lengths.	Intensity of Band.
4689	Strong.	3637	Weak.	4452	Strong.
4649	Strong.	3584	Weak.	4339	Strong.
4280	Very strong.	3546	Weak.	3975	Very strong.
4005	Strong.	3519	Very weak.	3652	Very strong.
3777	Weak.	3358	Strong.	3457	Strong.
		3330	Strong.		

The following are measurements of some lines which have been observed in the spark-spectra of these metals:—

	(Eder & Valenta.)	(Exner & Hasehek.)
<i>Copper</i> , . .	4649·31 sharp, 3777·17 diffuse.	4651·3, 4003·1, 3777·3.
<i>Silver</i> , . .	3358·79 not sharp, 3329·84 sharp.	3639·7, 3581·5, 3519·0, 3329·3.
<i>Gold</i> , . .	3976·8 diffuse. 3650·9 sharp.	3976·77, {3650·95, } 3457·05. {3653·70, }

A careful comparison of spark- with flame-spectra has led to the conclusion that the measurements quoted do not represent lines in the banded flame-spectra, although near to them.

The flame-spectra of copper and silver contain, in addition to the bands, two very strong lines in the same region of the spectrum, which appear also as

principal lines in their spark-spectra, and merge into bands in the flame-spectra, or broaden when the quantity of substance is large. This is a feature which has already been observed in these and other spectra.\*

Copper lines, wave-lengths,	. . .	3274 and 3248.
Silver lines, wave-lengths,	. . .	3383 and 3281.

There are no lines of gold corresponding to these in the same region, but one line of still higher refrangibility has been photographed, at wave-length 2675. The bands in the spectrum of gold are distinguished by being more refrangible than those which apparently correspond to them in the spectrum of copper; and we should, from this fact, and from the apparent homology of the spectra, expect the doublet of gold to lie in the same region of more refrangible rays. The line photographed is much weaker than the corresponding lines of silver and copper. We attribute this fact to the insufficiency of the energy of the flame to produce these more rapid vibrations with the same amplitude as in the less rapid vibrations of the copper and silver lines. The same want of energy is apparent in the spark-spectrum of gold.†

All of these five lines have an intensity of ten in the arc-spectra of the metals, and the second line of the gold doublet, wave-length 2428, not yet observed in the flame-spectrum, has also the maximum intensity.

The flame-spectrum of gold chloride, investigated by Mitscherlich, Lecocq de Boisbaudran, and Damarçay, does not appear to be related to the spectrum of the metal.

#### *Spectra of the Metals of the Alkaline Earths.*

Many bands are present in the oxyhydrogen flame-spectra of these metals. These bands, which differ entirely in character from those just described, have always been attributed to the oxides or to other compounds of the metals. They are diffuse and not degraded; neither are they composed of lines. We have no direct evidence of the compounds from which they are produced being dissociated in the flame, as is the case with the alkali metals, and we know that different compounds, when care is exercised that they shall not be converted into oxides or undergo dissociation, yield different band-spectra, though the metal be the same in each compound. The spectra obtained from oxides have already been examined.‡

#### *Spectra of Magnesium, Zinc, Cadmium, and Mercury.*

There are points of great interest in the flame-spectra of these metals.

Lines and bands are present in the spectrum of magnesium burning in air, and in the spectra of compounds of this metal heated in the oxyhydrogen flame. The

\* "Flame-Spectra at High Temperatures," Phil. Trans., vol. 185 (A.), 1894, p. 1029.

† Journ. Chem. Soc., vol. 41, 1882, p. 84.

‡ "Flame-Spectra at High Temperatures," *Loc. cit.*

bands are degraded towards the more refrangible end of the spectrum. The lines and bands have been described more or less perfectly by several observers, but the most complete account has been given by Liveing and Dewar.\* They describe a flame-spectrum of magnesium, consisting of flutings which they attribute to a combination of hydrogen with magnesium, and suppose it may be a chemical compound formed only within certain limits of temperature and dependent for its stability on the pressure of the gaseous element, like the instance of the hydrides of palladium, sodium, and potassium, investigated by Troost.

In attempting to photograph the flame-spectra of zinc and cadmium, the corresponding triplets in the visible spectrum were easily obtained; and in the spectrum of cadmium, a strong line of wave-length 3261 was also photographed. Traces of weak band-spectra were photographed in the violet part of the spectrum in each case; but it was only after many attempts that photographs were obtained upon which the bands were seen to be strongly marked.

The lines of impurities, such as lead, indium, thallium, &c., are much stronger in the photographs of some samples of "pure" metals than even those characteristic of the "pure" metals themselves. This is a proof of the low emissive power of the radiant molecules of the elements in the oxyhydrogen flame. It may perhaps be attributed to a smaller degree of volatility and greater heat of combustion, with less volatility of the oxide. The heat of combustion cannot, however, be the explanation in the case of mercury; neither can the volatility of the oxide. There may be a more profound cause for such a difference in these spectra, arising out of a peculiar mode of vibration set up within the ether by the monatomic molecules of the metals.

It is possible that a flame of a higher temperature will be required to produce the bands in a stronger degree. This is known to be the case with the lines of mercury.† The bands of zinc and cadmium were photographed with greatest success by heating the respective metals on cyanite supports in the oxyhydrogen flame, the spectra being received on a "Cadett Lightning Spectrum plate"; the time of exposure was for zinc 30 minutes, and for cadmium 20 minutes. The bands in these spectra are degraded towards the ultra-violet, and the lines of which they are composed are nebulous. The spectra are very complex. There appear to be two well-marked bands in each spectrum, and the two spectra are very similar in constitution. In addition to the two bands, weaker lines, which are components of other bands, are visible, and can be traced to the edge of the plate, wave-length 3530.

We were unable to photograph either lines or bands of mercury when its oxide, used as a convenient source of the metal, was heated in the oxyhydrogen flame. Both Mitscherlich and Liveing have observed lines in the spectrum of

\* Proc. Roy. Soc., vol. 32., 1881, p. 189.

† Mitscherlich, Phil. Mag., 1864, p. 178.

mercury heated in the cyanogen flame. More recently, Eder and Valenta\* have described a band-spectrum of mercury. They obtained it by passing electric sparks from a coil, without a Leyden jar, through mercury vapour as it distilled through a capillary tube. The band-spectrum of mercury has also been photographed by Huff,† who carefully exhausted the gases (air, &c.) from the tubes employed, and proved also that the band-spectrum was not due to the constituents of the glass. It is most probable that these bands will be observed in the flame-spectrum of mercury when the temperature of the flame is higher than that of the oxyhydrogen flame; as, for instance, in the oxy-acetylene flame. The bands of mercury obtained by other observers, generally by means of the spark, are similar in character to those of zinc and cadmium. They are degraded towards the ultra-violet, and the four metals of this group are alike, and peculiar in this respect.

References to the measurements of lines in the *spark-spectra* of elements, photographed by Eder and Valenta,‡ or Exner and Haschek,§ are distinguished by the initials E. & V. or E. & H. in the following tables of wave-lengths.

### THE FLAME-SPECTRUM OF MAGNESIUM,

*Between wave-lengths 5900 and 3530.*

Lines and bands degraded towards the violet.

Wave-lengths.	Description.
5209	A strong line. Degraded on the more refrangible side. It corresponds with one of the magnesium-hydrogen bands. (Living & Dewar.)
5184	A strong line.
5174	Line.
5168	Line.
5154	A weak line. Magnesium oxide according to Watts and Lecoeq de Boisbaudran.
5004	1st band.
4993	2nd "
83	3rd "
71	4th "
60	5th "
44	6th "
4572	A line according to Living & Dewar, common to flame, arc, and spark—(4571·3, Exner & Haschek.)
4100 } to } 3700 }	An exceedingly strong continuous spectrum.

\* Denkschr. d. kais. Akad. d. Wiss., Wien., Bd. Lxi., 1894.

† Astrophys. Journ., vol. xii., Sept., 1900, p. 111.

‡ Eder & Valenta. Denkschr. d. kais. Akad. d. Wiss., Wien.

Cu., Ag., and Au., Bd. 63, (1896). Cd., Bd. 61, (1894). Cd., Mg., Al., &c., Bd. 60, (1893).

§ Exner & Haschek. Sitzungsberichte d. kais. Akad. d. Wiss., Wien.

“Über die ultravioletten Funkspectra der Elemente.”

Ag., and Cu., Bd. cv., Abt. ii., (1896). Zn., Cd., Mg., Al., Bd. cvii., Abt. ii., (1897).

Strong lines of Ag., Cu., Pd., and Ir., Bd. cvii., Abt. ii., (1897).

Au., Bd. cviii., Abt. ii., (1898).

Be., In., La., Bd. cviii., Abt. ii., (1899).

It will be noticed that several lines belonging to the spark-spectra have nearly the same wave-length as lines or edges of bands in the flame-spectra of the same elements; but the lines are not really the same, they are not lines common to both spectra.

There is a strong continuous spectrum between the wave-lengths 5900 and 3530.

The following are wave-lengths of the ends of the bands in Liveing and Dewar's magnesium-hydrogen spectrum:—5618 to 5578, 5566 to 5526, 5513 to 5458, 5210 to 5183, 5180 to 5112, 4849 to 4813, 4803 to 4772.

### THE FLAME-SPECTRUM OF ZINC,

*Between wave-lengths 5900 and 3530.*

Bands composed of fine lines, degraded towards the violet.

Wave-lengths.	Description.
4900 to 4600	A strong continuous spectrum which becomes suddenly stronger at 4600. This is distinctly seen, when suitably magnified, to be composed of fine lines very close together.
4811	
4722	A triplet. { A spark line. 4810·1 Kirchhoff. "      "      4722 Huggins.          4722·37 Exner & Haschek. "      "      4680 Hartley & Adeney. 4680·4 Exner & Haschek.
4680	
4326	
4302	A broad line degraded towards the more refrangible side as far as 4320. The less refrangible end of a band which fades gradually on the more refrangible side.
4259	Line on a band, fairly strong. } weaker. } weakest. }
55	
50	
4245	A very weak line.
4240	Less refrangible edge of a band.
34	Component lines of this band. A spark line at 4195·7 Exner & Haschek.
29	
24	
19	
16	
11	
08	
03	
4197	
92	
86	
80	
74	
53	
47	
39	
30	
27	
19	
13	

The bands composing this spectrum can be distinguished as far as the edge of the plate ( $\lambda$  3530); but the component lines of the bands are too feeble and nebulous to admit of accurate measurements being made.

The lines are more widely separated as they approach towards wave-length 3530. The spark lines of similar wave-lengths to those of lines in the flame-spectrum are not the same, but really different lines.

THE FLAME-SPECTRUM OF CADMIUM,  
*Between wave-lengths 5900 and 3530.*

Bands composed of fine lines, degraded towards the violet.

*References.*—K. & R., *Kayser & Runge's arc-spectrum*; *r*, *reversed lines*; E. & V., *Eder & Valenta's spark-spectrum*; E. & H., *Exner & Haschek's spark-spectrum*.

Wave-lengths.	Description.	
5086	A triplet. { 5086·1 K. & R. <i>r</i> . 5086·1 E. & V., also Bell.	
4800		{ 4800·1 K. & R. <i>r</i> . 4800·1 E. & V., also Bell 4800·2.
4678		{ 4678·4 K. & R. <i>r</i> . 4678·4 E. & V., also Bell.
4508	A line degraded on the more refrangible side.	
4491	The less refrangible end of a band.	
62	The first distinct line, space between shaded, probably filled with close lines.	
57		Line.
53	Line.	
49	Line.	
	Space between shaded.	
23	Line, possibly the head of a band.	
17	Line. 4415·37 E. & H.	
11	,, 4413·2 E. & V. 4413·3 E. & H. 4413·2 broadened towards the red, K. & R.	
04		,, 4403·5 weak. E. & V.
4397	Two series of component lines forming a band can be traced here.	
89		
82		
74		
65		
60		
57		
53		
14	A line, degraded like 4508, on the more refrangible side.	
4298	The less refrangible end of a band. 4293·9 fairly sharp. E. & V.	
94	Component lines of this band.	
78		4214·0 fairly sharp. E. & V.
74		
70		
66		
62		
57		
53		
47		
41		
27		
21		
15		
08		
00		
4194		
86		
79	4177·5 E. & V.	
26	4127·5 E. & H. 4127·1 sharp. E. & V.	
4076	4075·8 weak. E. & V.	
58	4058·0 E. & H. 4057·5 sharp. E. & V.	
34	4035·1 fairly sharp. E. & V.	
32	4030·0 E. & H.	
08	4009·4 E. & H. 4009·2 weak, indistinct. E. & V.	

As in the zinc-spectrum, the bands can be distinguished as far as the edge of the plate ( $\lambda$  3530), but the component lines of the bands are too nebulous and feeble to admit of accurate measurements. The lines are much more widely separated towards wave-length 3530. The lines in the spark-spectra are not identical with those in the flame-spectrum, though several of them have nearly the same wave-length.

#### FLAME-SPECTRA OF ALUMINIUM, GALLIUM, INDIUM, AND THALLIUM.

The oxyhydrogen flame-spectrum of aluminium, really of the metal burning in the flame, is a channelled spectrum of fine flutings degraded towards the red\* It contains the bands which occur in the "arc-spectrum of aluminium oxide,"† and in the spark-spectrum under certain conditions.‡

When aluminium burns in the oxyhydrogen flame, the energy of the combustion is sufficient to volatilise some of the metal, and the flame is coloured blue. This colour is also seen in the flame when oxide of aluminium, in the form of thin rods, is heated in the hottest part of the flame. A stronger spectrum was obtained when a mixture of aluminium oxide, with a dense form of carbon, such as gas carbon or graphite, was heated. The doublet of aluminium, wave-lengths 3967 and 3946, was photographed by this method, but the bands have not been obtained in the same way.

Hemsalech confirms Aron's view, that the bands are really due to the metal, and not the oxide of aluminium.§

No bands have been observed by us in the spectrum of gallium,|| but the metal is so scarce, that no opportunity has occurred in which to examine the spectrum thoroughly.

Flutings not previously observed have been photographed in the flame-spectrum of indium, and in that of thallium; they are very much weaker than the lines of the strong doublets of indium with wave-lengths 4511 and 4102, and of thallium 5314 and 3775.

\* Hartley, *Phil. Trans.*, vol. 185 (A.), 1894, p. 211.

† Hasselberg, "*Kongl. Svenska Vet.-Akad. Hand.*," B. 24, 1892.

‡ Hemsalech, *Ann. der Physik*, 2, June, 1900, pp. 331-4.

§ *Loc. cit.*

|| The authors have discovered and directed attention to a convenient source of this metal. The cost of extraction will be very much less than by the process employed for extracting gallium from blende.



## THE FLAME-SPECTRUM OF INDIUM.

The spectrum consists of bands and lines, with the bands degraded towards the red.

Wave-lengths.	Description.
3978	The more refrangible edge of a band.
3953	" " " "
3902	" " " " weak.
*3837	" " " "
21	A nebulous line.
08	" "
3724	The more refrangible edge of a band.
3693	" " " "
17	A nebulous line.
3587	The more refrangible edge of a band.
3486	" " " "
47	A nebulous line or edge of a band.
18	The more refrangible edge of a band.
3388	" " " " strong.
23	" " " " strong.

## THE FLAME-SPECTRUM OF BERYLLIUM.

The oxide was heated in the oxyhydrogen flame. It is to be presumed that the spectrum is that of the metal and not of the oxide, as in the case of aluminium. The bands are degraded towards the red. The least refrangible line in the spark-spectrum is 4572·7 (Thalén) and 4571·9 (Kirchhoff). The arc-spectrum gives a line at 3904·7 (Lockyer).

Wave-lengths.	Description.
4780	} The more refrangible edges of narrow bands, degraded towards the red rays.
55	
33	
08	

\* A spark-line occurs near this wave-length, 3834·7 (Hartley & Adeney), also 3835·2 (Exner & Haschek).

## THE FLAME-SPECTRUM OF LANTHANUM.

The oxide was heated in the oxyhydrogen flame. Bands degraded towards the red.

Wave-lengths.	Description.	Remarks.
5710	Weakest. } Edges of component bands degraded towards the red. } Strongest. }	First Group.  Lines in Thalen's spark spectrum. 5656·5. 5631·0 double. 5602·0.
5682		
54		
29		
02		
5517	Weakest. } Edges of component bands with no marked differ- ences in intensity. } Strongest. }	Second Group.  5516·0. 5485·0.  5409·0. 5381·0.
5486		
71		
35		
09		
5382	Weakest. } Edges of component bands; easily distinguished, being well defined and degraded towards the red. } Strongest. }	Third Group.  4462·5 Di. ? 4457·5 Sm. 4452·0 Sm. 4446·0 Di. ?  4430·0. 4427·0.  4418·5 Sm.
4463		
58		
53		
47		
42		
37		
32		
27		
22		
18		
4379	Edge of band on the next group or band, the components of which are not distinguishable if there are any. Band degraded towards the red.	4379·5 Sm.
4371	Sharp and strong.	4370·1 Sm.

There appears to have been lanthanum in the preparation of samarium examined by Thalén, or samarium in this specimen of lanthanum nitrate. There was also probably lanthanum in Thalén's specimen of the didymium salt, from which the spark-spectrum was taken.

The flame-spectrum was taken from a specimen of lanthanum ammonium nitrate, kindly given by Professor C. M. Thompson, D.Sc. of the University College of South Wales, Cardiff. It had been prepared by the method of Auer v. Welsbach, from monazite.

It is to be remarked that Exner & Haschek give lines in the spark-spectrum of lanthanum, having wave-lengths which approximate to those of the edges of several bands in the third group of the flame-spectrum, viz. 4455·99, 4436·02, 4433·15, 4423·37, 4419·30, 4378·24.

## THE FLAME-SPECTRUM OF PALLADIUM.\*

Bands in the nature of flutings composed of fine lines.

Wave-lengths.	Description.	Remarks.
	A continuous spectrum extends from the green to wave-length 4648.	The large number of lines in the flame-spectrum of palladium lying beyond wave-length 4300 and extending to 3200 is not included in this description of the spectrum but only the banded portion. The lines are, however, very strong, and constitute a very important feature of the spectrum of this element.
4648	A nebulous line.	
22	" "	
14	" "	
04	A line.	
4598	A very weak line.	
88	A line.	
75	" "	
72	A weak line.	
65	A line.	
55	" "	
46	" "	
37	" "	
31	" "	
26	A weak line.	
20	A line.	
14	A weak line.	
11	A line.	
04	" "	
4497	" "	
89	" "	Exner & Haschek.
84	" "	
81	" "	
79	" "	
74	Termination of a band.	
65	A very weak line.	
61	" " "	
55	A broad weak line.	
46	A very weak line.	
43	" " "	
32	" " "	
29	" " "	
19	" " "	
07	" " "	
4399	" " "	
91	" " "	

In the course of this investigation experiments have been made with other elements. The following gave the spectra indicated below, but details are not yet sufficiently complete for publication:—

*Strong Continuous Spectra:* Molybdenum, tungsten, osmium.—A continuous spectrum, which is not strong, is rendered by mercury.

\* Wollaston was the discoverer of palladium, and the specimen from which this spectrum was taken was obtained directly from him, by the late Sir Robert Kane, F.R.S., by whom it was presented to W. N. Hartley, on April 25th, 1888.

*Band Spectra*: Arsenic, vanadium, yttrium, cerium, praseodymium, neodymium. The compounds of the last four elements under examination in all probability yield oxides, and the spectra are those of the oxides.

*Band and Line Spectra*: Nickel, cobalt, rhodium, and iridium.—Most probably the spectra are those of the metals.

It must be understood that the flame-spectra in these cases give lines in addition to bands, or bands in addition to line-spectra, sometimes as if they were components of different spectra, and in some cases as if the lines arose out of the edges of the bands by some change in the conditions of the flame.

*Germanium*.—Very faint indications of bands have been obtained also in the flame-spectrum of germanium.

There can now be no doubt that band or channelled spectra are given alike by metals as well as by metalloids such as tellurium and arsenic, or non-metallic elements such as sulphur and phosphorus. It is equally true that these bands are entirely due to the metals in many cases, though there are instances of bands or broad lines being undoubtedly rendered by compounds, as for example, under certain conditions, by the haloid salts of the alkaline-earth metals, also by haloid salts of gold and of copper.

---

#### CONCLUSIONS.

(1). Metals of very different characters belonging to different groups in the periodic system of classification yield banded spectra or spectra composed of both bands and distinct lines. As examples, we have magnesium, zinc, and cadmium; copper, silver, and gold; aluminium, indium, and thallium; palladium and iridium; bismuth, tin, and lead.

(2). Metals which are combustible and which evolve a large amount of heat upon combustion, forming oxides which are but slightly volatile, yield banded spectra; so also do those metals the oxides of which are easily volatilised, and furthermore, those metals that do not form oxides at the temperature of the flame.

(3). Certain groups of elements yield banded spectra which are degraded towards the less refrangible rays, as, for instance, the metals copper, silver, and gold; aluminium and indium; beryllium and lanthanum; others exhibit spectra the bands of which are degraded on the more refrangible side, as magnesium, zinc, and cadmium.

(4). Many lines, independent of those bands which are composed of fine lines, are present in the flame-spectra of palladium and iridium. Both of these metals are difficult to volatilise in the oxyhydrogen flame; hence only small quantities of the vapour are present in the flame. The same feature belongs to the spectra of some of the metals which are easily volatilised, when only small quantities are present.

(5). It is manifest that elements belonging to the same group in the periodic system of classification exhibit banded spectra which are similarly constituted, and hence similarly constituted molecules of the elements have similar modes of vibration, whether at the lower temperature of the flame or at the higher temperature of the arc.

Banded spectra are thus shown to be connected with the periodic law.

---

#### NOTE.

It has not appeared necessary to modify the view expressed by one of the authors in the first part of "Flame-Spectra at High Temperatures," namely, that the banded spectra of the elements are not primarily due to an allotropic condition of their vapours, nor solely to a lower temperature of the flame as compared with arc and spark spectra, but to the greater vapour pressure of these substances at the lower temperature, combined with the incandescence of their vapours. It is quite possible to imagine that such elements as lead, antimony, bismuth, and tellurium, under considerable pressures, yield continuous spectra, while, by lowering the pressure, the principal edges of the bands would alone appear, and even these would vanish until only lines remained. We have only to contrast what occurs in the combustion of hydrogen with oxygen at atmospheric pressures and under the pressure of thirty or forty atmospheres, wherein line-spectra of feeble radiant power become continuous and highly luminous spectra. It will be well to recall the instances from which the original deductions were drawn, namely, the case of bismuth containing lead and silver as impurities. The line-spectra of lead and silver appear as if laid upon the band-spectrum of bismuth, but no band of lead or silver can be traced. Since the temperature of the flame is not reduced, the only difference affecting the metals constituting impurities is one of vapour-pressure. The entire pressure of the mixed vapours is divided proportionally amongst the constituents of the mixture. If, for instance, the lead be one per cent. by weight of the mixed vapours, the partial pressure will be  $\frac{1}{100}$  of an atmosphere. Let us consider now the case of a substance like mercury or arsenic, both of which are very easily vapourised. The former, which is the best example, since mercury at the temperature of the oxyhydrogen flame is not oxidised, would evaporate so freely that it would pass out of the flame without attaining the temperature necessary for its incandescence. In the case of arsenic, we have this difference that, though the substance is easily vapourised, it is also at the same time oxidised, so that, in addition to the heat of the flame, we have the heat of combustion of the element causing incandescence. Substances, such as silver and gold with very high boiling points, which are not oxidisable metals, easily attain a temperature at which the vapour is incandescent, because the quantity of substance in the flame is not large. Other metals, which are easily oxidisable and have high boiling points, evolve a large amount of heat on combustion. Magnesium, zinc, and aluminium are conspicuous examples, and hence their vapours are rendered incandescent by the act of oxidation. Deductions as to the vapour-pressure of the substance in the flame were drawn also from the spectrum of manganese and alloys of manganese and iron. In tool-steel only the principal lines in the violet and a faint indication of bands in the yellowish green are seen; in spiegel-eisen the lines and the bands are well seen, while, in ferro-manganese and in pure manganese metal, the bands are the principal features, the spectra consisting almost entirely of bands; indeed in pure manganese even the group of lines in the violet becomes a band.

It may also be remarked that the yellow lines of sodium become a band when the quantity of substance increases in the flame, until in fact, finally a continuous spectrum is the result in which a strong band appears—W. N. HARTLEY.

## THE ILLUSTRATIONS, AND DESCRIPTION OF PLATES.

THE banded spectra yielded by the flame may be distinguished in the engravings by being three or four times as broad as the spark-spectrum, which, in every case, was photographed upon them. The spark-lines are taken from electrodes of cadmium-tin and cadmium-lead alloys, and are accompanied by air-lines; the wave-lengths of the metallic-lines and air-lines are accurately known, and from them the scales of wave-lengths have been drawn.

The less refrangible end of each of the flame-spectra is shown by the sodium lines; in the case of the lithium spectrum these have expanded into a band by reason of sodium being contained in the lithium nitrate, from which the spectrum was taken. The red, orange, and blue lines of lithium are well shown, and serve to indicate the facility with which they may be photographed when the quantity of substance in the flame is not too small.

Where there is no space for the wave-length numbers to be inserted immediately above the spectra, the scale is indicated, upon a faint horizontal line, by short lines.

Of the group—copper, silver, and gold—silver has already figured in "Flame-Spectra" (*Phil. Trans.*, 1894), and the lines and bands have been measured; copper, as copper oxide, has also been measured and described, but the gold spectrum is an entirely new one. The former measurements of the silver spectrum may differ slightly from those more recently made, not because they are less accurate, but by reason of the bands differing in width, or the intensity and breadth of the lines composing the bands varying either with the quantity of substance in the flame, or with the length of time during which the plate was exposed.

## PLATE XXIX.

1. GOLD, . . . . This spectrum is quite free from any trace of silver, copper, lead, or other impurities, except the sodium lines and the water-vapour lines beyond wave-length 3450, which appear, more or less, in all the spectra.
2. SILVER, . . . The flutings between wave-lengths 4000 and 3700 are not so well shown as in the illustration to "Flame-Spectra," Part I., *Phil. Trans.*, 1894.
3. COPPER.

## PLATE XXX.

4. CADMIUM, . . Detail not sufficiently strong to be reproduced with a distinctness equal to that seen in the original photographs.
5. ZINC.
6. MAGNESIUM.
7. LITHIUM, . . From the nitrate. The sodium-lines have broadened out to a band.

## PLATE XXXI.

8. THALLIUM, . . .
  9. INDIUM, . . .
  10. GALLIUM, . . .
- } The broadening out of the lines in these spectra is well seen, but faint bands have not been reproduced in the engraving.
11. ALUMINIUM, . . Besides the fluted spectrum, there is a band of continuous rays caused by the white-hot alumina.

## PLATE XXXII.

12. ARSENIC, . . The continuous spectrum, and the bands beyond wave-length 3000, are due to arsenic.
13. MERCURY, . . The lines seen are due to sodium, potassium, calcium, and iron.
14. MOLYBDENUM, From molybdenum trioxide.
15. LANTHANUM.

## PLATE XXXIII.

16. IRIIDIUM, . . There are several bands composed of lines, and some lines independent of bands, in this spectrum.
17. PALLADIUM, . A number of strong lines accompany the bands in this spectrum.

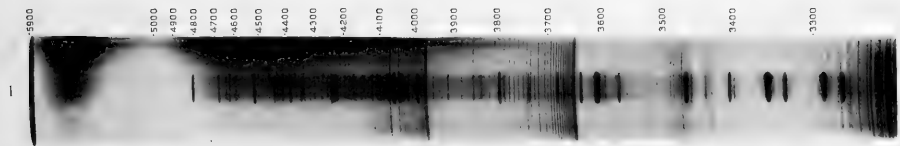

GOLD.

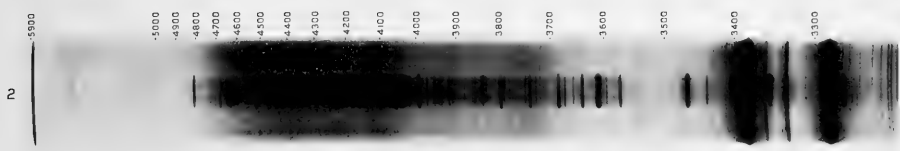

SILVER

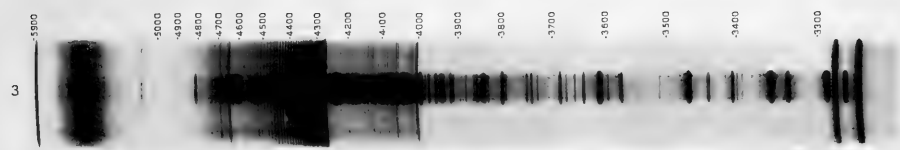

COPPER.

BANDED FLAME SPECTRA OF METALS.





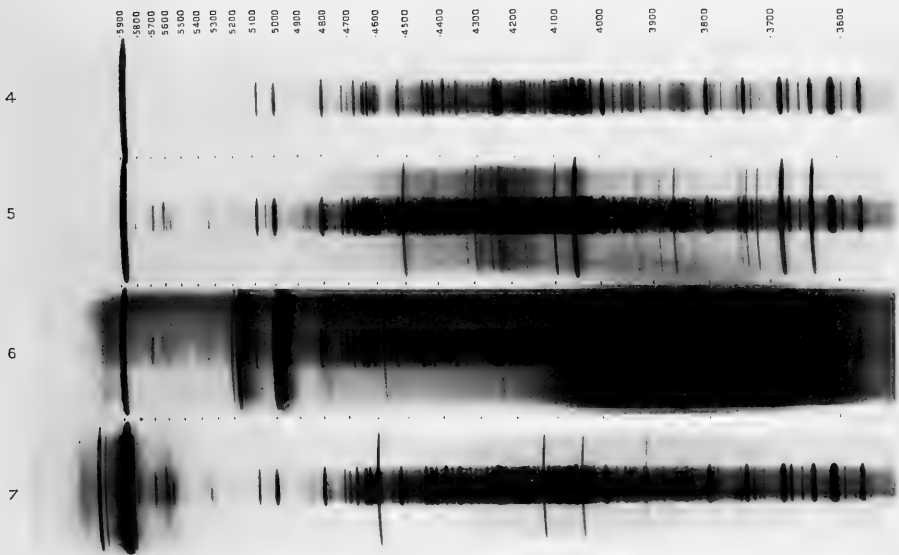

BANDED FLAME SPECTRA OF METALS.



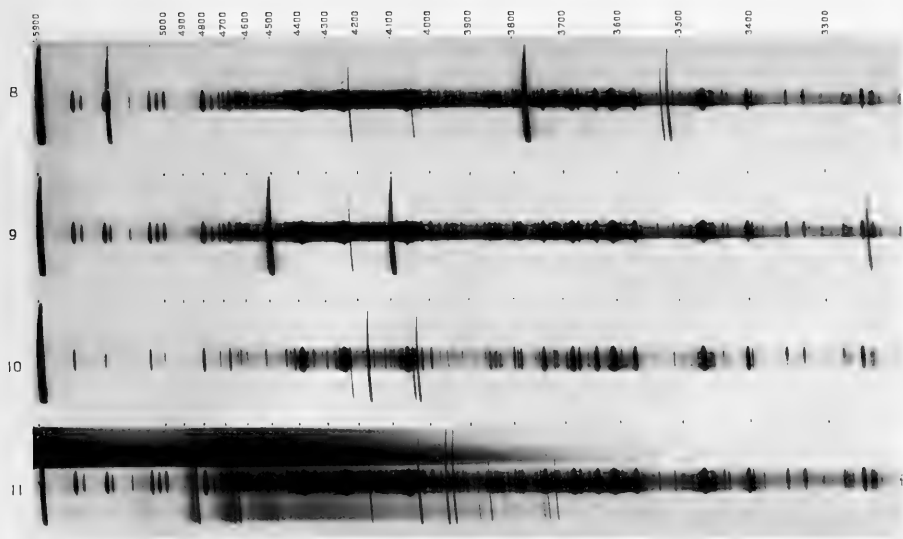

BANDED FLAME SPECTRA OF METALS



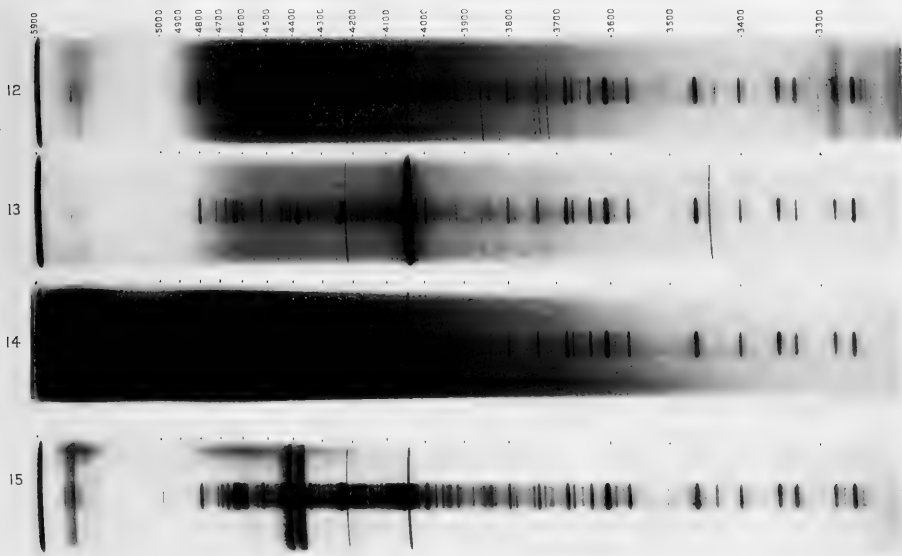

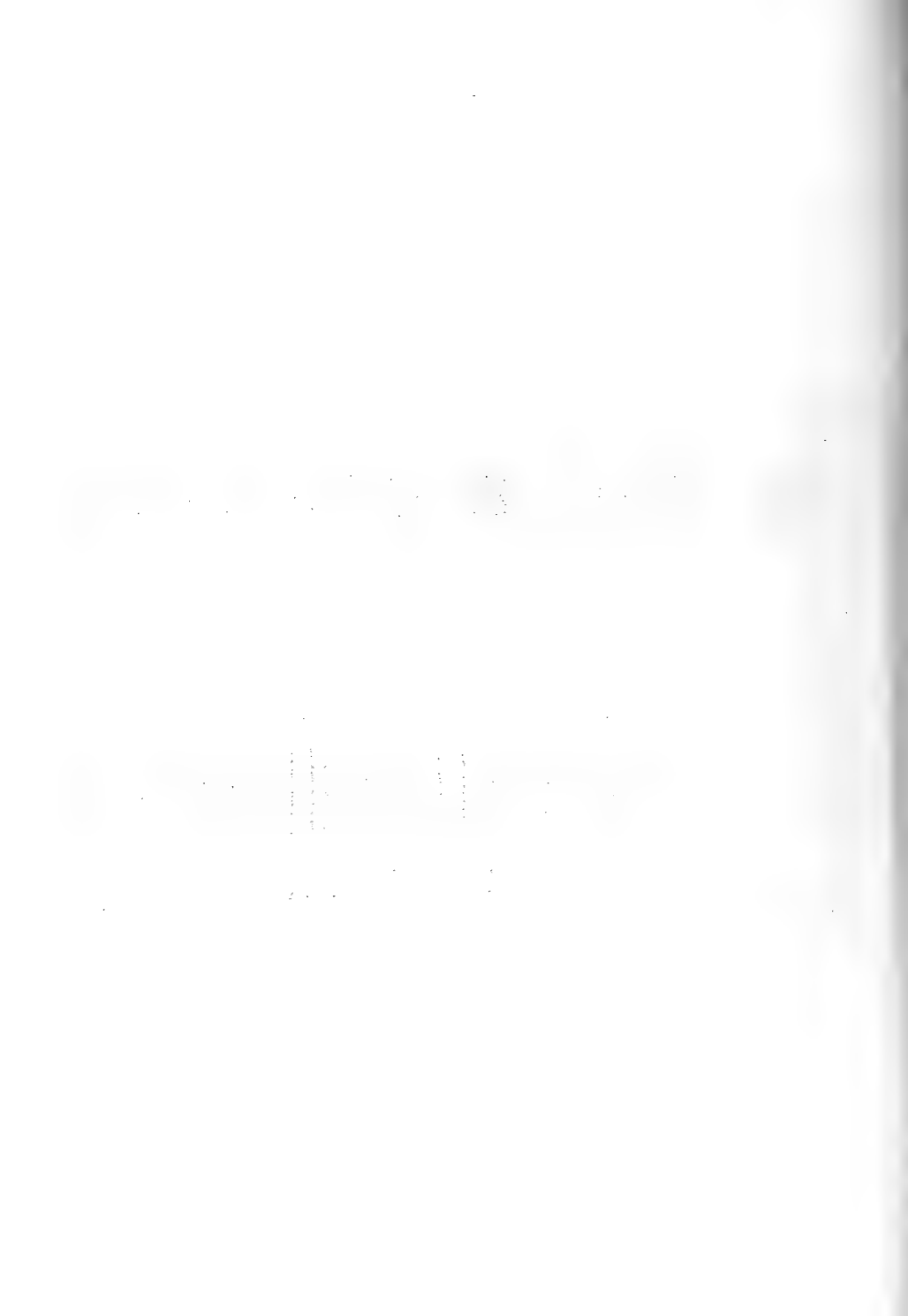

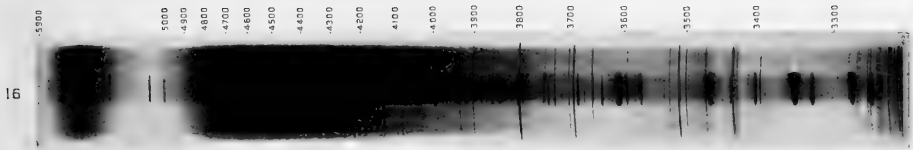

IRIDIUM

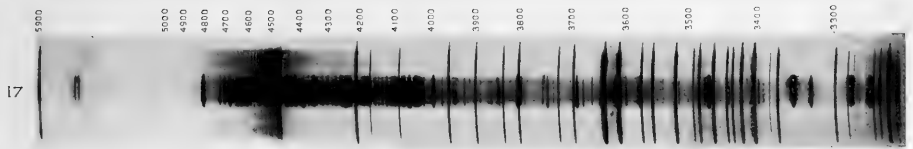

PALLADIUM.

BANDED FLAME SPECTRA OF METALS







## TRANSACTIONS (SERIES II.).

VOL. I.—Parts 1-25.—November, 1877, to September, 1883.

VOL. II.—Parts 1-2.—August, 1879, to April, 1882.

VOL. III.—Parts 1-14.—September, 1883, to November, 1887.

VOL. IV.—Parts 1-14.—April, 1888, to November, 1892.

VOL. V.—Parts 1-13.—May, 1893, to July, 1896.

VOL. VI.—Parts 1-16.—February, 1896, to August, 1898.

### VOLUME VII.

#### PART

1. A Determination of the Wave-lengths of the Principal Lines in the Spectrum of Gallium, showing their Identity with Two Lines in the Solar Spectrum. By W. N. HARTLEY, F.R.S., and HUGH RAMAGE, A.R.C.Sc.I. Plate I. (August, 1898.) 1s.
2. Radiating Phenomena in a Strong Magnetic Field. Part II.—Magnetic Perturbations of the Spectral Lines. By THOMAS PRESTON, M.A., D.Sc., F.R.S. (June, 1899.) 1s.
3. An Estimate of the Geological Age of the Earth. By J. JOLY, M.A., B.A.I., D.Sc., F.R.S., F.G.S., M.R.I.A., Honorary Secretary of the Royal Dublin Society; Professor of Geology and Mineralogy in the University of Dublin. (November, 1899.) 1s. 6d.
4. On the Electrical Conductivity and Magnetic Permeability of various Alloys of Iron. By W. F. BARRETT, F.R.S.; W. BROWN, B.Sc.; R. A. HADFIELD, M. Inst. C.E. Plates II. to IX. (January, 1900.) 4s.
5. On some Novel Thermo-Electric Phenomena. By W. F. BARRETT, F.R.S., Professor of Experimental Physics in the Royal College of Science for Ireland. Plate IXA. (January, 1900.) 1s.
6. Jamaican Actiniaria. Part II.—Stichodactylinae and Zoanthea. By J. E. DUERDEN, Assoc. R. C. Sc. (Lond.), Curator of the Museum of the Institute of Jamaica. Plates X. to XV. (January, 1900.) 3s.
7. Survey of Fishing Grounds, West Coast of Ireland, 1890-1891. X.—Report on the Crustacea Schizopoda of Ireland. By ERNEST W. L. HOLT, and W. I. BEAUMONT, B.A., Cantab. Plate XVI. (April, 1900.) 1s. 6d.
8. The Action of Heat on the Absorption Spectra and Chemical Constitution of Saline Solutions. By W. N. HARTLEY, F.R.S., Royal College of Science, Dublin. Plates XVII. to XXII. (September, 1900.) 3s. 6d.
9. On the Conditions of Equilibrium of Deliquescent and Hygroscopic Salts of Copper, Cobalt, and Nickel, with respect to Atmospheric Moisture. By W. N. HARTLEY, F.R.S., Honorary Fellow of King's College, London; Professor of Chemistry, Royal College of Science, Dublin. Plates XXIII., XXIV., and XXV. (July, 1901.) 1s.
10. A New Collimating-Telescope Gun-Sight for Large and Small Ordnance. By SIR HOWARD GRUBB, F.R.S., Vice-President, Royal Dublin Society. Plate XXVI. (August, 1901.) 1s.
11. Photographs of Spark Spectra from the Large Rowland Spectrometer in the Royal University of Ireland. Part I. The Ultra-Violet Spark Spectra of Iron, Cobalt, Nickel, Ruthenium, Rhodium, Palladium, Osmium, Iridium, Platinum, Potassium Chromate, Potassium Permanganate, and Gold. By W. E. ADENEY, D.Sc., A.R.C.Sc.I., Curator and Examiner in Chemistry in the Royal University of Ireland, Dublin. Plates XXVII. and XXVIII. (September, 1901.) 1s.
12. Banded Flame-Spectra of Metals. By W. N. HARTLEY, F.R.S., Honorary Fellow of King's College, London; Royal College of Science, Dublin; and HUGH RAMAGE, B.A., A.R.C.Sc.I., St. John's College, Cambridge. Plates XXIX. to XXXIII. (October, 1901.) 1s.
13. Variation: Germinal and Environmental. By J. C. EWART, M.D., F.R.S., Regius Professor of Natural History in the University of Edinburgh. (October, 1901.) 1s.

[OCTOBER, 1901.]

THE  
SCIENTIFIC TRANSACTIONS  
OF THE  
ROYAL DUBLIN SOCIETY.

VOLUME VII.—(SERIES II.)

---

XIII.

VARIATION: GERMINAL AND ENVIRONMENTAL.

BY

J. C. EWART, M.D., F.R.S.,

Regius Professor of Natural History in the University of Edinburgh.

---

DUBLIN:  
PUBLISHED BY THE ROYAL DUBLIN SOCIETY.  
WILLIAMS AND NORGATE,  
14, HENRIETTA STREET, COVENT GARDEN, LONDON;  
20, SOUTH FREDERICK STREET, EDINBURGH; AND 7, BROAD STREET, OXFORD.  
PRINTED AT THE UNIVERSITY PRESS, BY PONSONBY AND WELDRICK.  
1901.

---

*Price One Shilling.*



[OCTOBER, 1901.]

THE  
SCIENTIFIC TRANSACTIONS  
OF THE  
ROYAL DUBLIN SOCIETY.

VOLUME VII.—(SERIES II.)

---

XIII.

VARIATION: GERMINAL AND ENVIRONMENTAL.

BY

J. C. EWART, M.D., F.R.S.,

Regius Professor of Natural History in the University of Edinburgh.

---

DUBLIN:  
PUBLISHED BY THE ROYAL DUBLIN SOCIETY,  
WILLIAMS AND NORGATE,  
14, HENRIETTA STREET, COVENT GARDEN, LONDON;  
20, SOUTH FREDERICK STREET, EDINBURGH; AND 7, BROAD STREET, OXFORD.  
PRINTED AT THE UNIVERSITY PRESS, BY PONSONBY AND WELDRICK.  
1901.



## XIII.

## VARIATION: GERMINAL AND ENVIRONMENTAL.

BY J. C. EWART, M.D., F.R.S.

Regius Professor of Natural History in the University of Edinburgh.

[COMMUNICATED BY PROFESSOR D. J. CUNNINGHAM, M.D., F.R.S., VICE-PRESIDENT, ROY. DUBLIN SOCIETY.]

(READ MARCH 20, 1901.)

**Introductory.**

ALL are agreed that variability is intimately associated with changes in the protoplasm out of which animals and plants are made, but there is not yet universal agreement as to the causes of these changes. It may, however, be taken for granted that protoplasm has varied to produce recent and extinct organisms, either (1) because it was at the outset endowed with inherent internal attributes, or (2) because it has from the first been susceptible to the influence of external forces.

A century and a half ago certain naturalists (the extreme "preformationists" or "evolutionists") believed in the theory of encasement, or *emboîtement*, which not only implied that each ovum contained a complete fully formed embryo, but that each embryo contained ova for the next generation, these ova, other ova in their turn, and so on *ad infinitum*—Eve, for example, "encasing" all her descendants, each complete but necessarily infinitely minute.

The "preformationists" of the middle of last century—for a time championed by Bonnet—may be said to be now represented by neo-preformationists with Nägeli as their most scientific apologist. The main difference between the extreme old and extreme new "evolutionists" is, that the latter are, if anything, more thorough going, some of them believing that the protoplasm originally introduced was pre-ordained, or especially endowed with the power to give rise to a countless number of plants and animals quite uncontrolled by external stimuli—the external forces at the most playing a subordinate rôle, modifying or improving, but never interfering with or determining the line of development. Though it is not alleged that the original protoplasm contained miniatures of all the plants and animals

that have in due course appeared, an extreme latter-day preformationist might, at least, be willing to admit that it contained "germs" of the coming organisms. But there is no more evidence that protoplasm was originally endowed with the innate power of varying, irrespective of external stimuli, than that in the ovum of a bird or a mammal there lies concealed a fully formed and complete miniature of the adult. At the present day biologists (whether they are simple followers of Darwin, and are tinged with Lamarckism, or whether with Weismann they refuse to subscribe to the doctrine of the transmission of acquired characters) are nearly all agreed that variation has been mainly due, directly or indirectly, to the cumulative influence of external forces, such as food, light, heat, moisture, and the action of organisms on each other—in a word, to the influence of the environment.

For some years the question has not so much been "is protoplasm susceptible to external stimuli?" as "was the susceptibility lost when the metazoa stage in the phylogeny was reached, *i.e.* have variations in the metazoa been mainly due to stimuli influencing ages ago their protozoan ancestors?" Have the Vertebrates, and the other metazoa for countless ages been simply ringing the changes on variations accumulated by their remote simple unicellular progenitors? Professor Weismann, who (by his "ids" and "determinants") reminds one of the less extreme "preformationists," would probably still give an affirmative answer to this question, even though he believes that the germ-plasm "consists, to a great extent, of specific ids" and of only a few ancestral ones.\*

Hitherto students of evolution have generally discussed variation under two heads, *viz.* :—congenital variations and acquired variations. But, as in the case of mammals, certain congenital variations are really acquired and not necessarily transmitted, and as some variations which might very well be looked upon as acquired (*e.g.* variations due to differences in age and vigour, and to ripeness of germ-cells) are transmitted, I propose speaking of variations as Germinal and Environmental.

The most critical and momentous period in the life-history of any plant or animal is during the conjugation of the male and female germ-cells.

During conjugation (fertilization), as the germ-cells more or less completely blend with each other, and as new combinations, partly chemical and partly mechanical, are rapidly formed, the fate of the new individual is largely fixed. It is not so much that the conjugation causes variation, as that effect is given to variations inherited from near and remote ancestors or accumulated during the growth and maturation of the germ-cells. It is to this variation, which inevitably flows from the blending of the two highly specialized germ-cells, I have given the name Germinal Variation. During conjugation the minute details of the new

\* "The Germ-Plasm," p. 435.



individual may not be settled, but undoubtedly more occurs than the laying of the foundations. Subsequent to conjugation there is considerable scope for variation in the size, colour, vigour, &c., of the new individual, as there are possibilities of various changes of the germ-cells prior to conjugation. All the variations in the germ-cells up to the moment of conjugation, together with the variations during development and growth, I shall refer to as Environmental Variations.

## ENVIRONMENTAL VARIATION.

### I.—During Development.

It will be convenient first to consider environmental variations beginning with those that occur during development. By variation I understand difference in structure, habits, &c., between the offspring and their parents. These differences may be innate, *i.e.* have their roots in the changes in the germ-cells prior to conjugation, or they may be acquired after conjugation owing to every individual being plastic enough to respond, up to a certain point, to external stimuli. Further, these differences, whether germinal or environmental, may be established at birth, or they may appear at any period of the life-history, and some of the new departures may be handed on to the offspring of a subsequent if not the succeeding generation.

Hitherto it has been usually assumed that all congenital characters are transmitted to the offspring. But, if by congenital is meant characters pertaining or belonging to the individual at birth, this assumption is unwarranted: for, in addition to hereditary characters pertaining to the germ-plasm, *i.e.* inherited through the male and female germ-cells, and new characters created during conjugation, there are various characters acquired during development of a purely environmental and not necessarily transmissible nature.

In certain families a dwarf appears at irregular intervals. We rightly, I think, account for the occasional appearance of a dwarf by the principle of heredity—it is a case of recurring germinal variation. But all dwarfing is not due to hereditary influences; it is sometimes, though congenital, purely environmental. It may, *e.g.* be entirely due to an insufficient supply of nourishment.

Some time ago I found in a wild rabbit twelve young, eight in one uterus, four in the other. All the eight in the one uterus were of uniform size and quite as advanced in their development as the four (also uniform in size) in the other uterus, but they were only half the size. When the eight were placed in one

scale of a balance, and the four in the other, the four were found to weigh a few grains more than the eight. In this case the four fœtuses had evidently received the same amount of nourishment as the eight, and were, moreover, able to assimilate all they received. Had these twelve young been born, the eight small ones might, in course of time, have reached the same dimensions as the four large ones.\* Very often in a litter of rabbits one or two of the young are small and soon die off, but I once succeeded in rearing a rabbit that, even when nearly six weeks old, was little more than half the weight of the other members of the litter. Eventually the environmental dwarf nearly reached the size of its half wild parent, and produced perfectly normal offspring. Sometimes a child is born little more than half the usual weight, owing to deficient nourishment (*e.g.* to one or more knots in the umbilical cord). Such a child may grow into a man above the average size and have perfectly normal descendants. On three occasions foals from mares ill and out of condition during the period of gestation proved extremely weak and helpless. Of the three foals two died during the first year, but the third, though at first a characteristic "weed," is now (as a four-year-old) a fairly presentable animal, and only measures two inches less than his dam. By way of testing the influence of the immediate surroundings during development, I placed a doe rabbit in a cellar with a north light through which the direct sun's rays never penetrated during winter or spring—a cellar that by its unsanitary condition, and especially by its unsavoury smells, was extremely suggestive of a slum. This doe (after being mated with a half wild buck) was placed in the cellar on the 9th of April, and returned to her hutch on the 8th of May, the day before her young were due. The young only arrived on the 12th May, when, as it happened, I saw them born. There were six in all, two were dead at birth, and the remaining four all died within twenty-four hours. Since this unhealthy litter the doe has produced thirty-eight young all perfectly normal. Of these, six to the same buck were born after a second sojourn in the cellar; but during the second stay of four weeks the cellar was in part flooded almost daily with sunshine, and it was, moreover, better ventilated. In the above instance, though plenty of good food was provided, the period of gestation was prolonged, and the vitality of the young enormously reduced.

It would be a simple matter to give many instances of mammals born with one or more limbs wanting, or otherwise abnormal, owing often to constriction by the umbilical cord. Such "variations," though congenital, are neither inherited nor yet are they transmitted—they are abnormal environmental variations.

It thus appears that normal variations, during development (*i.e.* from the conjugation of the germ-cells to the time of hatching or birth), are frequently due to an inadequate supply of nourishment.

\* The fœtal rabbits were within about five days of birth.

II.—**Environmental changes from the end of development to the end of the reproductive period, including changes in the germ-cells during their growth and maturation.**

(1). *Experiments bearing on the question of the inheritance of acquired characters.*

Every plant and animal has a certain amount of plasticity, just as every species has certain potentialities.

In virtue of this plasticity both plants and animals, by responding to external stimuli, are able, during their lifetime, to adapt themselves, within certain limits, to their environment. By treating individual plants and animals of the same variety differently—no matter how intimately related—surprisingly diverse results (difference in size, in the time maturity is reached, fertility, &c.) are sometimes obtained, nurture during at least the individual life having, in many cases, a wonderful power over nature. Can any of the results of nurture (acquired, it may be, at the expense of much time and energy), changes in habit, or in structure, in size or colour, in mind or muscle, be handed on even in a modified way to the offspring? In other words, is it possible, in some incomprehensible way, to engraft on the germ-plasm specific somatic changes acquired during the life of the individual, *i.e.* to transmute definite environmental somatic variations into germinal variations? To this still burning question many, following Darwin, would give an affirmative answer, while Weismann and his followers would as unhesitatingly reply in the negative.

Darwin, Spencer, and many others—doubting, apparently, the sufficiency of germinal variations, and failing, perhaps, to realize sufficiently the influence of the environment on the germ-plasm—imported into the new evolution hypothesis some of the old hypotheses generally associated with the name of Lamarck. Hence, until Weismann adversely criticised the want of confidence alike of prophets and followers in the new doctrines, and insisted on the all-sufficiency of congenital (germinal) variation, it was commonly believed that all sorts of peculiar mental and physical traits—normal and abnormal—acquired for the first time by the parents, could be handed on practically unchanged to their offspring.

I have not yet met with any evidence in support of the belief that specific acquired somatic variations are hereditary. On the contrary, many of my results indicate that the handing on, even in a highly modified form of definite (non-latent) traits acquired during the lifetime, is extremely improbable.

Some of these results may be worth mentioning. Hitherto tails and horns

have had a strange fascination for believers in the transmission doctrine. That the tail is sometimes congenitally absent from animals whose ancestors have not been subjected to docking is well known, but I am not aware that any recent attempt has been made to ascertain if the congenital ecaudate condition is, as a rule, transmitted to the immediate or subsequent offspring. There is a large body of evidence that cutting off the tail in mice does not produce a tailless breed, but I am not aware of any experiments of the kind with rabbits.

About a year ago I found in a litter of rabbits one absolutely tailless, the parents, grey half-wild rabbits, had tails of the usual length. Never having heard of a "Manx" rabbit, the somewhat delicate sport was carefully reared, and in due time mated with a member of his own litter, and with several unrelated does. Altogether I bred, in this way, thirty-two young. In every one of them the tail was perfectly normal, and it is also normal in all the members of the following generations that have already appeared. If a rabbit born without a tail—and hence, presumably, a prepotent "sport"—is incapable of producing tailless descendants, it is unlikely that a rabbit which, whether by accident or design, lost its tail after birth, would produce tailless offspring.

Cropping the ears of dogs gives even more suggestive results than cutting off the tail in mice. Terriers whose ancestors, for many generations, had their ears cropped, instead of being nearly earless, have frequently abnormally large ears. This is, doubtless, because cropping gave large- as well as small-eared individuals a chance of leaving descendants.

During the last four years I have crossed several different kinds of fancy pigeons. The great lesson learned is, that it is difficult to combine the distinctive characters of two well-marked breeds. When, *e.g.*, a turbit with a pronounced peak and frill is crossed with an ordinary pigeon, both peak and frill vanish, and when a barb is crossed with an owl also decorated with a "frill," only plain birds are ordinarily obtained. If characters (probably sports to start with) which have prevailed for many generations are not readily transmitted except when two like varieties are interbred, it seems to me improbable that a definite acquired character—a trait that has never had a chance of being burned in—can by any chance be transmitted.

Breeders believe that shorthorns and other breeds of cattle are more docile, mature earlier, and are more fertile than feral cattle. Fanciers believe tame rabbits, pigeons, &c., are less timid and nervous than wild ones; and in the same way sportsmen imagine that pointers, setters, and retrievers work well because their ancestors have been long subjected to careful training. In as far as our domestic animals are docile, mature early, are highly fertile and easily trained, it is, I believe, because our ancestors found it convenient, or most profitable, to select and breed

from the most docile and most fertile members of their flocks and herds, the tamest and least nervous of their rabbits, pigeons, &c., and the fleetest or keenest scented of their hounds, and not because acquired variations are transmitted.

If definite acquired variations are not transmitted in cultivated plants or domestic animals, it is inconceivable that they are transmitted in human beings, that the higher branches of the human family owe any of their finer traits (aptness to acquire knowledge and the like) to the gradual accumulation during many generations of specific somatic (non-germinal) variations.

(2). *The influence of nutrition and somatic well-being on the germ-plasm.*

If it is impossible to endow the offspring with special somatic characters or traits acquired in virtue of a heritage of individual plasticity, let us see whether there is any evidence that the germ-cells more or less accurately reflect the condition or general fitness of the individual in which they are formed, as buds bear an intimate relation to the plant on which they grow. Though there is no evidence that the blacksmith can endow his children with a strong right arm, there may be good reasons for believing that the germ-plasm of a mature, vigorous, healthy individual, is likely, other things being equal (*e.g.* the prepotency), to overcome, during the conjugation of the germ-cells, the germ-plasm of a less matured and less mentally and physically fit individual. If it can be shown that the germ-plasm not only in a way reflects the vigour or general fitness of the somatic tissues, but also that the condition (*e.g.* ripeness) of the germ-plasm to a certain extent determines the nature of the combinations formed during conjugation, and also whether the male or female parent will control the development, it will be evident that the environment is indirectly an important factor in causing variation, without which progressive development is impossible.

I find some horses, colts as well as fillies, mature sooner than others; that most horses reach maturity sooner than zebra-horse hybrids, and that hybrids mature sooner than zebras. Again I find that the cross-bred offspring of pigeons obtained in the early spring differ in various ways from birds bred during summer. In the case of fillies, the ones kept indoors and well fed during the winter reach maturity sooner than the fillies infested with the parasite *strongylus*, or allowed to run out all winter. Further, while there are often signs of ovulation in stall-fed mares all through the year, mares only receiving hay, and the occasional shelter of a shed during winter, may only begin to show signs of ovulation in April or May. Again, animals in too good a condition, like animals out of condition, owing, *e.g.*, to a change of habitat, are often, at least for a time, sterile.

(3). *The influence of age, seasonal condition, &c., of the parents on the nature of the progeny.*

Crossing black barb and grey English owl pigeons first suggested that the characters of the offspring depended to a certain extent on the age, maturity, &c., of the parents. During early spring the owl-barb crosses were devoid of character, but later in the season some of them united all the distinctive points of both breeds, one, *e.g.*, was black like the barb, with a breast frill like the owl, while later still they reproduced fairly accurately the owl sire. Late in the season the "owl" suffered from some lung affection, and eventually died, leaving the barb in charge of two eggs within a few days of hatching. The barb having lost interest in the eggs, they were transferred to a pair of fantails and one was hatched, but again a bird of an inferior type made its appearance. These results led me to make a long series of experiments with the view of ascertaining whether the maturity (*i.e.* the age) of the parents in any way determined the nature of the progeny. I first discovered that pure-bred (which is, as a rule, another name for inbred) birds were, owing to their great prepotency, ill adapted for my purpose. Crosses between a handsome red Jacobin and a black barb were accordingly made, and subsequently mated with a turbit and other breeds. A young female Jacobin-barb, nearly intermediate between its parents, was, when still quite young, placed with an old male turbit. After an interval of nearly two months, the Jacobin-barb laid two eggs of nearly uniform size, and eventually two hen-birds were reared, one in colour exactly like the turbit, the other only differing from the turbit in having a few coloured breast feathers. Both the young birds were absolutely devoid of any vestige of either hood, chain, peak, or frill, *i.e.* none of the distinctive points of either Jacobin-barb or turbit were reproduced. For over a year the turbit had been continuously endeavouring, without success, to rear offspring with his closely inbred granddaughter. But for this the turbit might have endowed the offspring by his new mate with at least hints of his special decorations.\*

The first birds reared, a second pair of eggs were laid—the hen bird being now in excellent form and feather. As the second pair of cross-bred young grew, it became more and more evident they would develop a "hood" nearly as complete as that of their dam. Now that they are full grown they, in their make and attitudes as well as in their decorations, remotely resemble Jacobins; while in the plan of their colouring they resemble turbits. The birds of the second nest (like those of the third and fourth nests) form a very striking contrast with the birds of

\*It is evidently difficult for one parent to transmit his or her specializations, unless they are of the nature of highly exclusive sports, or exist in at least a latent form in the other parent.

the first, notwithstanding the fact that the surroundings have been as nearly as possible the same since the parents were first mated—the food, temperature, light, &c., having been practically constant. No birds were hatched from the fifth, sixth, and seventh nests, and before the eighth pair of eggs were laid the hen bird was out of condition. Perhaps for this reason the single bird obtained from the eighth nest more closely resembled the turbit than those hatched from the first pair of eggs. I can only account for the marked contrast between the first and the subsequent young by saying, that as the female parent increased in age and vigour her germ-cells increased in prepotency.\*

(4). *The influence of age of the parents and of the ripeness of the germ-cells.*

Similar results having been obtained with other pigeons, I next turned my attention to rabbits, partly because they offered better facilities than pigeons for further experiments, and partly because I was anxious, if possible, to discover what has always struck me as a very remarkable phenomenon—why the members of a given family, brood, or litter sometimes so decidedly differ from each other.

Finding wild rabbits excessively timid, and, except in rare cases, all but untamable, I decided to use half-wild specimens. Having made sure that a number of tame white does bred pure, I set them free in an old sand-pit, and ere long had a large number of half-wild young at my disposal. I also succeeded in breeding half-wild specimens, by mating wild does with a large white Angora. All the half-wild rabbits bred were in every respect extremely like pure wild rabbits both in form and colour. The half-breeds by the Angora not only resembled the common wild form in colour, but also in being excessively timid and quick in their movements. Further, in their attitudes, they resembled wild rabbits, more especially in keeping the ears, as is the custom of wild rabbits when crouching, pressed firmly over the shoulders. Some of the half-breeds were of a light-grey colour to start with, but as they grew older the wild colour was gradually assumed, the characteristic dark hairs of the ears and tail being always present.

\* Some of the results obtained by breeders also support the view that the age is influential in determining the character of the offspring. For some reason or other Galloway cattle are extremely prepotent. This prepotency is strikingly illustrated when a Galloway bull is mated with long-horned, long-haired, yellow or red Highland heifers—cattle undoubtedly of an older type than the Galloways. The offspring of these unions are sometimes so like the black hornless parent that experts are unable to say which members of a herd are crosses, which pure Galloways. When, however, old Highland cows are crossed with a young Galloway bull, the calves, it is said, may be either yellow, red, or black, and sometimes they are provided with distinct vestiges of horns.

Provided with a stock of half-wild rabbits, the next thing was to see what would happen when they were crossed with white rabbits, and with each other.

I first crossed a white doe, having a trace of Himalaya blood (indicated by her light-grey snout, ears, feet, and tail), with a half-wild buck, and obtained four grey does—slightly lighter than their half-wild sire—a black buck with two white patches, and a buck built like a wild rabbit, but in colour very like a Himalaya. Somewhat similar results were obtained with other white does, and by crossing half-wild does with white bucks; *i.e.* there were always several colours represented in the cross-bred litters.

(a). *Interbreeding a cause of variation.*

The result of mating the half-breeds with each other was sufficiently unexpected. The half-wilds were so uniform in colour and size that I imagined their offspring would also be fairly uniform; but instead of uniformity there was an epidemic of variation. Of eight young, the offspring of the grey half-wild rabbits, one was grey, one squirrel-coloured—a tint occasionally seen amongst wild rabbits—one was pure white, one slaty-blue, one of a brownish tint, one black and white, and two were yellow and white. They differ in other respects, the black, *e.g.* has a leg crooked like the fore-legs of a basset hound, and the grey is absolutely tailless; the does matured and had young at different times, and differed in their fertility, and in the care of their young, while the grey one was much later in reaching maturity than his squirrel-like brother. Moreover, in disposition they were very different. The squirrel-coloured one became the fiercest buck I have ever had—he routed males nearly twice his size; the slaty-blue, on the contrary, is extremely small and unobtrusive; and while the white and the yellow and white ones fed frequently, the others fed hurriedly at intervals, hiding away at other times. Weighed when six weeks old, they varied from nine to seventeen and a half ounces.

By way of accounting for so much variation in the organic world, for the evolution of so many kinds of plants and animals since our planet was capable of sustaining life, it has been suggested that, at the outset, variation was both more common and more pronounced than it is now. I think the difference between the present and the past is rather that while, at the beginning, if five or six distinct varieties appeared they would all have a chance of establishing themselves, now, owing to almost every possible niche being occupied with forms admirably adapted for the particular environment, there is so much competition that it is almost impossible—almost a miracle—if a new variety manages to obtain a footing without supplanting an already existing variety.



Even now, it is only necessary to interbreed half-bred animals, the offspring of two varieties that have long lived apart, or cross-fertilize plants in which self-fertilization has been the rule, in order to obtain an epidemic of variation, to induce a more or less prolonged period of "sporting."\*

From the offspring of the half-breeds varying so much, it is evident that, though they were all wonderfully like wild rabbits, the stability of the wild rabbit had been lost, that, as it is said of plants, crossing had broken down the "constitution." But it may be mentioned, the stability can soon be restored by engaging in inter-breeding—which usually leads to exactly opposite results from inter-crossing—and that even without close inter-breeding the "sporting" tendency gradually wanes.

Two of the offspring of the half-breeds (the grey- and the squirrel-coloured ones) I crossed with pure white does, and with grey quarter-wild does. The invariable result was a litter of mixed colours.

By the crossings mentioned, and many others on record, I satisfied myself (1) that under ordinary circumstances wild rabbits, bred with tame white bucks or does, yielded grey rabbits; (2) that half-wild rabbits, whether bred with each other or with white rabbits, yielded offspring of three or more colours; (3) that the offspring of two half-wild rabbits (even if grey), when bred with each other, or with the grey offspring of a half-wild and a white rabbit, yielded young of several colours; and (4) that there is an intimate relation between the colour and (*a*) the "wildness," (*b*) the time maturity is reached, and (*c*) the rate of growth—white individuals being tamer and sooner mature than grey.

(*b*). *Result of mating does before and after the normal time.*

It is commonly believed by some (*e.g.* many gamekeepers and sportsmen) that rabbits begin to breed when about six weeks old, while others assert that they only reach maturity when six months old. At what age wild rabbits reach maturity I have not determined, but I find tame and half-wild does living under favourable conditions frequently mature during the fourteenth week, and have their first litter during the eighteenth or nineteenth week, *i.e.*, before they are five months old. Anticipating that four grey does (the offspring of a half-wild buck and a white doe) born on the 8th February, 1899, would soon reach maturity, I placed one with an Angora buck on the 10th June, *i.e.* when thirteen weeks old. Though the doe was

\* Were this power of "sporting" (varying) lost, a species would lose its power of adapting itself to changes in the environment, and thus run the risk of extinction. Every pronounced change in the surroundings usually leads to a certain amount of mixing up (with its inevitable intercrossing) of forms which, in their germ-plasm, if not in their outward characters, somewhat differ from each other.

not in season, the buck served her, with the result that she had two young forty days afterwards, *i.e.* on the 20th July. I proved subsequently that this doe carries her young thirty days, which means that, though she was served on the 10th of June, ovulation only occurred ten days later, on the 20th June, and this of course implies that, in the rabbit, spermatozoa may retain their fertilizing power for at least ten days after they reach the fallopian tube. The two young rabbits were pure white, and when they grew up they readily passed for half-bred Angoras. The three grey sisters of this doe only reached maturity during their sixteenth week, from which it may perhaps be inferred that the presence of the sperms in the oviduct induced premature ovulation in the dam of the two white half Angoras. A few hours after the two white young were born I put their dam, the grey doe, to a grey buck, a descendant of two half-wild rabbits. Thirty days afterwards (on the 19th August) she had ten young—five grey, two bluish-grey, and three white.

Ovulation does not seem to occur in the rabbit before the act of insemination, but it is generally said that the doe refuses to take the buck for some weeks unless presented to him during the first, second, or third day after parturition. I have, however, several does that have been successfully served from nine to eighteen days after the birth of their young.

Instead of serving the grey doe on the 19th August—the day she had her ten young—I postponed the service until the 6th September, *i.e.* eighteen days beyond the usual time. This time I again used the Angora buck, with the result that on the night of the 6th October the doe had four young, all of which were in every respect identical with new-born, half-wild and wild rabbits. To make what follows clear, I may here explain that, about a week or ten days before the young arrive, the female rabbit (tame as well as wild, when the circumstances permit) excavates a nest nearly at right angles to the main burrow, lines it with grass or hay, and then carefully closes up the opening with sand or, in the case of tame rabbits, with whatever material may be available—the nest is doubtless made thus early to give the grass lining time to dry. Two or three days before the young are born the nest is re-entered and provided with an inner lining of hair which the doe very cleverly tears off her breast and sides. Finally, as the young are one by one born, the fetal robes are, with wonderful dispatch, torn asunder and devoured along with the placenta. After the all but hairless young have been well licked—which warms them as well as cleans them—they are arranged in a clump and roofed over with a light covering of hair: this covering is dispensed with when the hair of the young is sufficiently developed.

The grey doe served on the 6th September made no preparations whatever for the young born during the night of the 6th October. On the morning of the 7th October, one was already dead, the other three were sprawling about in a

semi-torpid condition. As their dam neither attempted to protect nor suckle them, they all died during the first day, and were added to my museum. This peculiar behaviour of the doe led me to surmise that something unusual might happen. I find I wrote in the stud book on the 7th October :—" Will this grey doe have another lot of young about the 16th October." On the 11th October the doe proceeded to make a nest, but before the lining of hair was added, three more young were born, exactly a week after the first lot, *i.e.* on the 14th of October. They were slightly smaller than the first litter, and, like the first, they soon died, their dam never attempting to suckle them. The chief point of interest about the last batch of young is, that they varied in colour; had they survived, one would have been white, one probably blue or silver grey, and one like a wild rabbit.

When this grey doe had sufficiently recovered her equilibrium, she was again put to the Angora buck, and on the 27th December she had six young, two white—identical with the two white of her first litter—and four grey, two of them with patches of white.

Service was again postponed, with the result that this grey doe a second time produced to the Angora buck grey young like herself. In further support of the view that, when the sperms are introduced some time before ovulation, the young are likely to take after the buck, I may mention, that in the case of a white rabbit served by a grey half-wild buck thirty-eight days before she littered, the offspring exactly resembled the buck—served by the same buck at the normal time, the offspring were of various colours.

From these and other experiments it appears—(1) that when a doe rabbit is served one or more days before the normal time, the young resemble the buck; (2) that when insemination is delayed, the young are likely to resemble the doe; and (3) that when insemination takes place at the usual time, some of the young take after the doe, some after the buck, while others may differ from both parents and resemble some of the less remote ancestors; and (4) that in the rabbit spermatozoa retain their potency several days after they reach the fallopian tube.

In support of the view that the members of the first litter of the grey doe were white like the sire, while the third litter consisted of dark young like the dam and her half-wild sire, the extremely important results obtained by Mr. H. M. Vernon with echinoderms may be cited. It will be remembered that Vernon, on crossing *Sphærechinus* females with *Strongylocentrotus* males, found that, in summer, when *Strongylocentrotus* have but small quantities of ripe sexual products, the majority of the hybrids " were of an almost pure *Sphærechinus* type, only a third or less of them being of an intermediate or *Strongylocentrotus* type," but that, " *as the maturity of the Strongylocentrotus sperm increases, it is able to transmute first*

a portion and then the whole of the hybrid larvæ from the *Sphærechinus* to its own type. In other words, the characteristics of the hybrid offspring depend directly on the relative degrees of maturity of the sexual products.”\*

(5). *Why members of a family differ.*

To return to the question, “Why is there sometimes so much difference between the individual members of a family?” it may be replied, that the individuals differ because the cells from which they are respectively developed differ; the potential difference of the cells being greater than the actual difference of the individuals derived from them. Hence, an attempt to account for the difference between members of the same family does not consist in studying selection or the changes that accompany conjugation. It resolves itself into an attempt to explain in what respects the cells from which the offspring are separately and independently developed differ from each other. It is conceivable that the individual germ-cells entering into the formation of any given family may differ both morphologically and physiologically. Each germ-cell, up to a certain point, may be said to be comparable to a simple protozoon. Each protozoon, however simple, and though only capable of reproducing itself by fission, has a life-history. The life-history begins at the moment of separation and ends when the process of fusion or conjugation sets in. This may be very short or relatively long; but, however short, there will be time for complex metabolic changes, for minute fluctuations in its vital units. The protozoon may be well or ill-nourished; it may have matured (*i.e.*, become capable of dividing) rapidly or slowly; it may divide prematurely, or the process of fission may be delayed, and, when fission does occur, there may be unequal division of the nucleus.

In the case of the female germ-cell three stages may be recognised in the life-history—(1) the stage up to the discharge of the first polar body; (2) the stage characterised by the extrusion of the second polar body; and (3) the stage between the reducing division and the union of the nuclei of the ovum and the spermatozoon—*i.e.* up to the moment of conjugation. During the first stage the ovum, like a protozoon, may be ill- or well-nourished, the growth may be fast or slow throughout, or, by sudden changes in temperature, &c., rapid at one time, retarded at another, or slow at first and so hurried at the end that ovulation takes place prematurely. Moreover, if only one or two ova are ripening in, say, the right ovary, and quite a number in the left, the right ones may have the advantage and some of those in the left may be inadequately nourished, just as ova,

\* *Proceed. Roy. Soc.*, vol. lxi.ii., May, 1898.

irrespective of the general condition, may be better nourished in one individual than another.

Again, the ova discharged at the outset of the reproductive period may, in various respects, differ from ova formed later, and these may again differ from ova produced as senescence supervenes.

Coming now to the second stage, the extremely important and much-discussed question arises—"Does the protoplasm discharged from the nucleus in the second polar body differ from the protoplasm retained, *i.e.* is the reduction qualitative as well as quantitative?" If during reduction it is possible for the germ-plasm representing the immediate or intermediate ancestors of any individual or group of individuals to escape, we may have in the "reducing division" a sufficient means of accounting for a certain amount of variation.\*

During the third stage, *i.e.* during the time that intervenes between the "reducing division" and the union with the spermatozoon, the changes which take place may have no small influence in settling the fate of the new individual. That important changes occur in ova not only before and during maturation, but especially after the escape of the polar bodies, may be assumed by the difference in the staining-reaction of the nucleus. In the newt, *e.g.*, according to Watasé,† germ-nuclei not only stain differently throughout the whole period of their maturation, but also up to the end of fertilization. It almost appears as if conjugation were impossible in some cases until certain chemical or physical changes occur in the matured ovum, or in its immediate environment. The Hertwigs ‡ *e.g.* showed that when the vitality of ova was diminished by shaking them in water and allowing them to stand for some time, cross-fertilization was more easily accomplished, while Born§ found that cross-fertilization was expedited by adding a superabundance of sperm. It has also been proved by Vernon that the stale germ-cells of echinoderms behave after a time very differently from fresh germ-cells. Up to a certain time the development is normal, then there is about 1 per cent. of abnormal blastulæ per hour, after which the number of abnormal blastulæ may be nearly 20 per cent. per hour. What is, perhaps, more remarkable is, that stale sperms give, with fresh ova, larvæ distinctly larger than when both sperms and ova are fresh, while stale ova with fresh sperms produce abnormally small larvæ.

\* Weismann's theory of heredity takes for granted that the germ-plasm discharged in the polar bodies may be quite different from the germ-plasm which remains to conjugate with the entering spermatozoon. It may never be possible by direct observation to prove whether this assumption is or is not warranted; but it may be possible by experiment to prove, on the one hand, that it is an inadequate explanation, and, on the other, that cumulative differences in the nutrition, ripeness, &c., of the germ-cells are sufficient to account for much of the variation we find in organic nature.

† Wilson, "The Cell," p. 127.

‡ *Jenaische Zeitschrift f. Medicin*, vol. 19 (1886).

§ *Pflüger's Archiv*, vol. 32, p. 453.

Mr. Vernon is careful to point out—(1) that his results “prove the inequality of the sex-cells, stale ova and fresh sperms giving very different results from fresh ova and stale sperms, which implies that it is more important to have fresh ova than fresh sperms,\* unless intercrossing is aimed at, when fresh sperms seem to be essential”; and (2) that staleness may be a very potent cause of variation, “the relative degree of freshness of ovum and spermatozoon at the time of fertilization being in many cases entirely a matter of chance.”†

In the case of the spermatozoon, three phases may also be recognised—(1) a fairly long period (when changes in the nutrition, &c., may account for much), which ends with the formation of the second spermatocytes; (2) the period including the division of the spermatocytes to form spermatids—equivalent to the reducing division stage in ova—and the growth of the spermatids into spermatozoa; and (3) the period between the completion of the spermatozoon and its union (conjugation) with an ovum—a period which may extend over months or even years. Even although the spermatozoa are, as a rule, extremely minute, it has been possible to observe that their nuclei differ in their staining-reaction from the corresponding egg-nuclei, and also that the nuclei of immature sperms stain differently from the nuclei of mature sperms. Further, observation may possibly show that the sperms formed at the beginning of the period of reproduction differ in staining-reaction from those formed when the climax is reached, as well as from those formed during senescence, and that in domestic mammals (dogs, horses, &c., at stud) the sperms produced at the beginning of the breeding season differ considerably not only in their staining-reaction, but also chemically from those formed towards the end of the breeding season.

### GERMINAL VARIATION.

By germinal variation I mean the variation that results from the union or conjugation of the germ-cells. As already stated, the germ-cells up to the moment of union are liable to be influenced by external stimuli, to undergo environmental variation. During conjugation, as the nucleus of the male germ-cell blends with its equivalent, the “reduced” nucleus of the female germ-cell, all the variations inherited, as well as the potential environmental variations accumulated during the growth and maturation of the germ-cells, have an opportunity of asserting themselves, that they are never all embodied in the new

\* According to Loeb, the ova of echinoderms placed in chloride of magnesium, and then in sea-water, develop into larvæ without being fertilized. “Biology Lectures,” Woods Holl, Boston, 1899.

† *Proceed. Roy. Soc.*, vol. lxx., Nov., 1899.

individual eventually developed will be readily admitted. Were it possible to measure accurately the potential variability of two germ-cells before conjugation, there are good reasons for believing that, owing to inequalities of nutrition, assimilation, &c., the ovum, independently of the "reducing division," would be different morphologically from the ovisperm, out of which the female parent was developed, as the sperm would differ from the ovisperm which gave rise to the male parent. Moreover the two germ-cells would differ physiologically, in *e.g.* their ripeness and vigour as a whole, and in the ripeness, vigour, &c., of some of the groups of vital units, ancestral protoplasm being prepotent in some groups, specific or racial protoplasm in others. The result of these various differences, would be that the new individual, when developed, would not in its characters assume the intermediate position which an estimate of the structure of the two germ-cells might have led us to anticipate.

In other words, there are excellent reasons for supposing that though amphimixis is not a cause of variation, it consists in something more than the mere mechanical blending of what might be known as the structural variations of the two germ-cells. When a paper-maker introduces two kinds of pulp into one end of his machine, he knows to a nicety the kind of paper that will stream off at the other end. When, however, the eggs of one variety of fish are fertilized by the milt of a different variety, the pisciculturalist is unable to predict the exact form, colour, &c., of the fish which will eventually appear in his hatching boxes. In the same way, a breeder, when he crosses, say, a piebald mare, with two apparently identical bay ponies, may obtain a bay foal the one year, a piebald foal the next.

Having failed to find any experimental evidence of the transmission of acquired specific variations, and having given reasons for the belief that the germ-cells differ from each other in their nutrition, ripeness, &c., and that the ova are especially liable to change after the escape of the second polar body, I may now attempt to indicate how the differences in the germ-cells count in shaping the destiny of the new individual.

At the beginning of a campaign, or, for that matter, of a modern battle spread over a wide area, it is impossible, or at least unwise, to predict what the final issue will be, even when a fairly accurate estimate of the resources of the two combatants is available, and allowance is made for the physical conditions under which the operations are conducted. In the same way, it is impossible, and ever will remain impossible, to predict what will be the result of the union of two germ-cells, even when the ancestral history is well known, and when the parents have been living from their birth under similar conditions.

When the male and female germ-cells meet, a whole series of campaigns is entered on with ever varying results.

Hitherto, the tendency with many has been to regard conjugation as little more than a mere mechanical mixing of vital units, partly derived from the parents, and partly from the ancestors.

Many breeders assume that one-quarter of the "blood" of the offspring is derived from the four grandparents, and one-eighth from the great-grandparents.

According to Galton's law of heredity, a law which has formed the basis of so many elaborate calculations, the two parents contribute half, the four grandparents one-fourth, the eight great-grand parents one-eighth, and so on of the total heritage of the average offspring. This law may or may not apply to some sections of the human family, but it does not profess to express the results obtained when one of the parents is decidedly prepotent, nor yet, I imagine, does it profess to indicate what happens when intercrossing is resorted to.

Wilhelm Roux (following in the wake of Spencer), with a fine insight, has applied the principle of selection to the individual parts of the organism, and Weismann, in elaborating this brilliant conception, has especially insisted on the view, that "even the smallest living particles contend one with another, and those that succeed best in securing food and place, grow and multiply rapidly, and so displace those that are less suitably equipped";\* and further, that the cause which gives the advantage to one particle over others, and the consequent possibility of struggle, "is to be sought in the relative power of reaction to a definite stimulus, and in the fact that a functional stimulus strengthens an organ."\* To the universal contention between equivalent parts, Weismann gives the name "*intra-selection.*"

In the case of the ovisperm, the energy for the struggle between the equivalent parts is inherited or stored up during the growth and maturation of the germ-cells, the stimuli coming mainly in the form of nourishment under varying conditions through a long line of ancestors. In the ovisperm it is not, I imagine, so much a contention between the individual vital units as a struggle between groups of units; the most vigorous, most prepotent, though often in a minority, gaining the victory.

As in a public meeting there may be several factions, and as in a representative assembly several parties, so in the mass of protoplasm, formed by the union of a male and female germ-cell, there may be several contending groups of vital units struggling for supremacy. In mediæval tournaments, various kinds of competitors entered the lists, from the simple bowman to the knight in complete armour. In the same way in the ovisperm, in addition to the groups of vital units representing the latest developments of the variety or species, there are groups

\* Romanes' "Lectures," London, 1894, p. 12.



representing remote as well as intermediate stages in the ancestral history. Judging by the results, one of the immediate ancestors may control the development, or the control may be about equally divided between immediate, intermediate, and remote ancestors, the issue, as in many battles, being decided by the quality, individuality, or character (what we call the prepotency) of the successful groups of vital units, rather than by their numbers.

*The combined results of germinal and environmental variation.*

As variation is intimately associated with intercrossing, the best way to illustrate the combined results of germinal variation and the variation in the germ-plasm due to food, temperature, &c., *i.e.* environmental variation, will be to give the results of a number of intercrossing and interbreeding experiments.

It may be said that intercrossing only differs from ordinary cross-fertilization, in that the results appear in larger type, are, as it were, magnified. This is true of intercrossing between closely allied races, but not of intercrossing between distinct varieties, and still less between different species. In the latter there is, to use the same simile, a difference in the character as well as in the size of the letters, in most cases a reversion to simpler and more primæval forms. When for several generations, the ancestors have been intimately related and almost identical in characters, the offspring, as a rule, resemble the parents, doubtless, because the vital units or groups of units proceeding from both parents have all very similar tendencies.

Whether, when the parents have been living under very different conditions, and differ in age, vigour, &c., variability (environmental variation) shows itself in the offspring, has not yet been systematically investigated.

The following are some of the more striking results of intercrossing:—

1. The offspring may, down to the remotest details, be all but intermediate between the two parents. Examples of this intermediate condition, though not very common, certainly occur. In a cross between black and white birds, black and white feathers may alternate with each other, over a considerable part, if not over the whole body. This once happened in a cross-bred pigeon, and the same thing happens in plants, in *e.g.* a cross between two species of the tobacco plant, *Nicotiana rustica* and *N. paniculata*.\*

In such cases it may be presumed that equally nourished, equally matured, and equally prepotent germ-cells meet and blend in such a way that both parents are

\* Külleutter, "Vorläufige Nachricht von einigen das Geschlecht der Pflanzen betreffenden Versuchen und Beobachtungen," 1716.

equally represented. Had the germ-cells in the case of the pigeons succeeded in developing apart, they would have given rise to twins, one black like the male parent, the other the image of the white female parent.

2. The offspring may resemble one of the parents. This is frequently the case when wild members of a species are crossed with tame varieties of the same species, *e.g.* when wild and tame rabbits, rats, and mice are intercrossed. The same result is sometimes obtained by crossing members of two distinct genera. When the orchid *Zygopetalum Mackayi* is crossed with certain species of *Odontoglossum* (*e.g.* *Pescatorei* and *crispum*), the hybrids are "*Zygopetalum Mackayi*," pure and simple, without any trace of the peculiar structure of the pollen parent in any case.\*

Very often one tame variety is prepotent over another. I have a yellow and white (skewbald) pony that two years ago produced to a bay pony a foal, which in its colour, disposition, and gait is the image of her dam. When quite young, this pony produced to a sire, more prepotent than herself, a dark dun-coloured foal. That Galloway are prepotent over Highland cattle has already been mentioned. In the same way, a silver-grey rabbit proved prepotent over a Himalaya doe—of thirty-nine young, all resembled in colour, though not in make, the silver grey buck. So in pigeons, one breed of a given colour may prevail. A "restored" rock pigeon proved on one occasion prepotent over a barb, and a white fan, the offspring of two blue fans, produced a perfectly white bird when mated with his own dam.

We often account for the prepotency of one genus, species, variety, or race, by saying it belongs to an older type. This explanation, however, is sometimes at fault, for quite a new type may be prepotent over an old one. Some time ago I saw in Kent a "calico" or "painted" mule spotted all over like an Indian "painted" (pinta) pony. As a rule mules are more like the ass sire than the horse dam, but when the dam is a "sport" some of the hybrid offspring may fairly accurately reproduce her recently acquired peculiarities, such as spots or large blotches. Again, a dark variety of the peppered moth has recently largely displaced the older and lighter variety over a considerable part of England.

In these cases the result evidently depends on the germ-plasm of one of the parents being overpowering, able to dominate the germ-plasm provided by the other parent—on the germ-plasms being antagonistic or at least incapable of blending.

Hence it follows that in some cases the prepotency may be regarded as quite independent of the environment, in *e.g.* the wild rabbit, rat, and mouse, while, in others, it may, to a considerable extent, depend on the maturity of the germ-cells.

\* Hurst, *Nature*, Dec. 22, 1898.

Further experiments may, however, show that, by special treatment, the prepotency of even wild rabbits, rats, &c., and also of *Zygopetalum* and other plants, can be reduced, if not for a time destroyed. Highly specialized characters are but rarely transmitted to cross-bred offspring. A genius, if a sport, may, like a spotted pony, transmit his special traits, even if he unites himself with an alien distinguished only for mediocrity, but this rarely happens. When two richly decorated varieties or species are crossed, the special features are often either lost or greatly modified, as, for example, when pheasants are intercrossed. A similar result follows the crossing of a decorated with a plain or whole coloured variety or species, even when the plain form has sprung from richly-coloured ancestors. Evidence of this we often have when pheasants and fowls are crossed, and when the zebra is bred with the horse or ass, or a spotted dog is mated with a wolf.

The pheasant-fowl hybrid may approach the pheasant, but the rich colouring is never fully realized, while the zebra seems quite incapable of endowing his hybrid offspring with his light body-colour—or with his own particular pattern of stripes. The same, though to a less extent, is true of lion-tiger crosses, and crosses between differently coloured fowls, pigeons, rabbits, guinea pigs, &c. The explanation doubtless is, that the highly specialized traits may have been recently acquired (partly owing to environmental stimuli), and may be more of the nature of decorations than life-saving characters. This implies that, unless they happen to be sports, they will be unstable and only capable of fully reproducing themselves if represented by at least a few corresponding vital units in the germ-cell of the less specialized parent.

3. Some of the offspring may resemble one of the parents, some the other. This is well illustrated by a litter of four kittens, two of which are pure white, like the sire, two are tabby, coloured like the dam. In litters of puppies, both parents are often very faithfully reproduced. Recently, in a cross-bred family having a small black and tan spaniel as the dam and a lemon and white pointer as the sire, there were both pointer and spaniel-like pups—one of the former, now clearly double the size of his dam, in make and colour closely resembles his sire.

In a litter of rabbits between a half-bred wild buck and a doe, with faint Himalaya markings, one most accurately in make, colour, &c., copies the doe, another is, if anything, more like a wild rabbit than the buck. Other examples might be given from amongst sheep and pigs, mice, and pigeons. In these cases the germ-cells seem to be so evenly balanced that very little difference in their vigour, ripeness, or “staleness” probably settles the matter one way or the other. But the chief interest of the germ-plasm refusing to blend is this, that it gives a new variety a chance of establishing itself. A new variety may (1) establish itself if it is capable of multiplying more rapidly than the old variety, and is at the same time equally well adapted for its surroundings; or (2) if it is better adapted for the

particular environment, but in both cases there will be danger from the "swamping effects of intercrossing." This danger will obviously be avoided if, when the new and old varieties intercross, the offspring are either the image of the old or of the new. If, in addition to an inability to produce intermediate forms, the new variety is better adapted for the environment, it will survive even if its increase is at first slow.

4. The offspring may combine, almost unimpaired, the more striking characters of both breeds. Though the engrafting of the characters of one breed on another may not be common, it certainly occurs. Two instances may be mentioned: (1) In crossing a barb with an "owl," the frill of the owl on two separate occasions made its appearance on the offspring, one of which, from a fancier's point of view, was, apart from its frill, a better barb than its pure-bred barb parent; (2) In crossing a home-made Himalaya rabbit with an Angora, two young were obtained, having the long hair of the Angora and the dark markings of the Himalaya. That it is possible to roll two races or breeds into one is extremely interesting and suggestive. Darwin supposed that when two distinctive types were crossed, reversion followed from a kind of antagonism, *i.e.* from the germ-plasm of one type opposing and neutralizing the germ-plasm of the other. What happens when intercrossing is practised evidently largely depends on the prepotency of the parents, or, to be more accurate, on the prepotency of the germ-cells lodged in the parents. This prepotency may again depend partly on the inheritance, and partly on the environment from the outset of development up to the time when maturity is well established. When the characters of one race are engrafted on those of another, it is not, I believe, because there is an absence of antagonism; it is rather that in both germ-cells there is almost sufficient energy to give rise, unaided, to a new individual. The Skewbald pony producing a foal as like herself as if it had grown from a cutting or bud, supports this view, but still stronger support is afforded by the recent work of Yves Delage,\* who has succeeded in obtaining larval echinoderms, worms, and molluscs by fertilizing enucleated eggs. If in nature, two distinct types occasionally blend, it will be evident that the rate of evolution, even without the help of occasional "sports" may have been infinitely more rapid than Darwin and many of his followers imagined. If the blending of external characters is possible, it may almost be taken for granted that the blending of mental characters is also possible. I find when my zebra hybrids are intensely striped, they exhibit practically all the mental traits of their zebra sire. This might, perhaps, have been anticipated, for the epidermis and its appendages and the central nervous system are akin in their origin. Hence, from the fact that distinctive epidermic characters of one variety of pigeons can be engrafted on quite a different variety, it may be inferred that,

\* Archives de Zoologie Experimentale, Oct., 1899.

though the crossing of two very distinct human races often leads to disastrous results, intermarriage between members of some of the higher branches of the human family may prove highly beneficial—that, in fact, there may be progress, mental as well as physical, without the transmission, so long thought necessary, of definite traits acquired by the nervous, muscular or other systems during the individual lifetime.

As the combining of two sets of characters in the offspring is probably comparatively rare, it may be taken for granted that it is only possible when the environment is particularly favourable—when the food is plentiful, the assimilation perfect, the germ-cells well nourished and about equally prepotent, and all the climatic conditions are pre-eminently suitable.

5. Sometimes new, or at least unexpected, characters appear in the offspring. The grey tailless rabbit was an example of an unexpected character which was certainly not due to reversion\*—though there may have been tailless rabbits before. Though this is a congenital variation, it is not necessarily a germinal one. In two rabbits that died a few hours after birth, the tail was represented by a shrivelled process about the thickness of a bristle—evidently the tail, normal enough in the young embryo, had atrophied during development. If the tendency to atrophy is inherited, the variation would belong to the germinal and not to the environmental group.

One of the many kinds of tame mice is a Japanese variety that, whenever it moves, tends to spin round. Last November, I noticed that three out of four of a litter of twenty-one days old rabbits, frequently spun round at a great rate. When on the way to their food they would suddenly begin to wheel like a dog after its tail, sometimes from right to left, sometimes from left to right, and they always spin round when disturbed.\* The sire of the spinners is a half-wild rabbit, the dam an Angora-Himalaya. The fourth member of the litter is extremely like a wild rabbit in its attitudes as well as in make and colour. Never once has it been observed spinning.

I shall only mention three other instances of variation. In a black rabbit, the offspring of two half-wild rabbits, one of the fore-legs is crooked, as if it belonged to a basset or dachshund. In another, but quite unrelated rabbit—one of the spinners—both fore-legs are so bent that the feet turn inwards as is sometimes the case in short-legged Skye terriers. All these variations have occurred in cross-bred families, but variability also occurs without intercrossing.

Recently I saw two rooks from a rookery near Edinburgh, which were of a reddish-brown or chestnut tint. If similarly coloured and equally prepotent rooks continue to appear a new variety may be established.

\* Spinning rabbits would have little chance of surviving in a wild state.

6. The offspring of half-breeds are, as a rule, extremely variable—a fact long recognised by breeders, fanciers, and horticulturalists. Half-wild rabbits are surprisingly uniform in their colour, size, time of reaching maturity, &c., yet when interbred, even if closely related, they produce highly varying offspring. Evidence of this we have in the litter of eight already referred to, the members of which differed in every possible way—in structure, colour, size, weight, disposition and habits, vitality, time of reaching maturity, and in the preparations made for, and the care taken of, their young. What is true of rabbits is more or less true of mice, pigeons, and of many other animals, and of plants, more especially of plants in which cross-fertilization does not ordinarily occur. In orchids, as in rabbits and mice, first crosses are uniform in their characters, but when the first crosses are interbred, variation at once sets in, some resembling the parent species, others the immediate parents, while others form a series of links between the parents and the less remote ancestors, or differ from all the known ancestors. This “sporting” as it is often called, may continue for several generations, but it eventually subsides as the potency of one particular variety is fixed by inbreeding. The epidemic of variation that often sooner or later result from intercrossing, followed by interbreeding, seems to be partly due to the mixing-up of two kinds of germ-plasm having different tendencies, partly to an increase of vigour induced by intercrossing. Every variety and species in a state of nature in order to survive, must, on the one hand, be capable of varying with its ever-changing surroundings, but, on the other hand, to prevent waste, it should not at any given time vary too much. Excess of variation is checked by inbreeding, which often, for economical reasons, is as great as the vigour of the variety or species permits. But, for inbreeding, the members of a species would probably be too sensitive to external stimuli. When the “constitution” is broken down by intercrossing the influence of the environment—food, temperature, &c.—seems to reach a climax. The characters of the secondary and tertiary and other crosses still depend on what happens during conjugation (germinal variation), but this is apparently influenced to an unusual extent by the condition of the parents, the nutrition and ripeness of the germ-cells, and especially by the retrogressive changes in the ova after the “reducing division.”

7. Sometimes the offspring, instead of resembling the immediate ancestors, *i.e.* the parents, resemble former ancestors. One or more of the members of a family may, *e.g.*, resemble a grandparent, or a comparatively remote ancestor, or one of the intermediate ancestors. Whether, in any given case, the resemblance to a former ancestor is due to retrogressive variation (reversion or regression), it is impossible to say. Nevertheless, in most cases, a fairly satisfactory answer can be given. When the offspring all but exactly agree with a grandparent or even a

great-grandparent, one need not hesitate in believing that the resemblance is due to the principle of reversion, but when the resemblance is to a supposed ancestor thousands of generations removed, one must hesitate before adopting the reversion hypothesis. Take, *e.g.* the following case:—A cross between a pigeon known to fanciers as an “archangel,” and another known as an “owl,” when mated with a white fantail, hatched out a bird very like a chequered blue rock pigeon. One might say the blue rock-like pigeon was a sport, not a revert. It would, if a sport, be a very striking one, and presumably characterized by great prepotency. By breeding the blue rock-like cross first with a barb, and then with a white fantail, I proved conclusively enough that, instead of being pre-eminently impressive, it behaved like any other cross-bred pigeon. Of the two possible explanations, the one that regards the blue bird as a revert seems to me to be the simplest, if it implies that the restoration of the characters of the blue rock has resulted from the ancestral germ-plasm having surged to the surface and obtained control during development. One may cross pigeons for many years without, as a fancier would say, being lucky enough to produce a blue rock. It can, however, be easily done, if certain conditions are observed. The experimenter must first aim at obtaining a nondescript bird—a mongrel in fact—this secured, it should be mated with a bird of quite a different strain and history. If the pure bred birds are incapable of stamping their characters on the offspring, a bird like a blue rock may be obtained.

In the “owl” we have a not very prepotent bird, probably evolved in North Africa; in the “archangel” we have a highly specialized but not specially impressive bird, said to be a product of Northern Russia, and hence not likely to be closely related to the owl. It is not surprising that a cross between an owl and an archangel is absolutely without character, and yet about as far removed from a white fantail as could well be imagined. Hence, when crossed with a white fantail the germ-plasm in its efforts to form a highly specialized tail, the characteristic snowy whiteness, and unique carriage, being unsupported, may completely fail in the attempt. On the other hand, the owl-archangel mongrel, being like melted wax, counts as nothing, and thus the ancestral germ-plasm (*i.e.* the germ-plasm representing the original stock from which all the numerous varieties of pigeons have sprung) asserts itself, and all but entirely controls the development.

This may not be the true, but it seems to me to be the most feasible, as it is the simplest, explanation that can well be offered of what is undoubtedly a very remarkable phenomenon—the all but complete restoration of an ancestor probably many thousands of generations removed.

It is worth mentioning that in my restored rock pigeon, the tail, though consisting of the normal twelve feathers (instead of thirty as in the white fantail sire) is slightly expanded at the apex and very slightly arched in the centre; moreover, the claw of the left hallux is white, all the others are dark in colour. The single white

claw and the faint arching of the tail may be held as indicating that the units of germ-plasm contributed by the male white fantail sire contested every inch of ground throughout the whole period of development, and that, when a small point is gained, it may be held to the last. Even in inbred stock, reversion occasionally occurs. Further experiments may show that the slight reversions familiar to breeders are due to loss of vigour in one or both of the parents.

Recently acquired characters are the first to go, not, I think, because the vital units representing them are few in number, but because they are wanting in vigour or something akin to vigour. Hence, when the stress comes they deteriorate and ultimately count for little or nothing, with the result that the new individual is launched into the world minus the decorations and other traits that characterized the variety or race to which it by birth belongs.





## TRANSACTIONS (SERIES II.).

- VOL. I.—Parts 1-25.—November, 1877, to September, 1883.  
VOL. II.—Parts 1-2.—August, 1879, to April, 1882.  
VOL. III.—Parts 1-14.—September, 1883, to November, 1887.  
VOL. IV.—Parts 1-14.—April, 1888, to November, 1892.  
VOL. V.—Parts 1-13.—May, 1893, to July, 1896.  
VOL. VI.—Parts 1-16.—February, 1896, to August, 1898.

### VOLUME VII.

PART

1. A Determination of the Wave-lengths of the Principal Lines in the Spectrum of Gallium, showing their Identity with Two Lines in the Solar Spectrum. By W. N. HARTLEY, F.R.S., and HUGH RAMAGE, A.R.C.Sc.I. Plate I. (August, 1898.) 1s.
2. Radiating Phenomena in a Strong Magnetic Field. Part II.—Magnetic Perturbations of the Spectral Lines. By THOMAS PRESTON, M.A., D.Sc., F.R.S. (June, 1899.) 1s.
3. An Estimate of the Geological Age of the Earth. By J. JOLY, M.A., B.A.T., D.Sc., F.R.S., F.G.S., M.R.I.A., Honorary Secretary of the Royal Dublin Society; Professor of Geology and Mineralogy in the University of Dublin. (November, 1899.) 1s. 6d.
4. On the Electrical Conductivity and Magnetic Permeability of various Alloys of Iron. By W. F. BARRETT, F.R.S.; W. BROWN, B.Sc.; R. A. HADFIELD, M. Inst. C.E. Plates II. to IX. (January, 1900.) 4s.
5. On some Novel Thermo-Electric Phenomena. By W. F. BARRETT, F.R.S., Professor of Experimental Physics in the Royal College of Science for Ireland. Plate IXA. (January, 1900.) 1s.
6. Jamaican Actinaria. Part II.—Stichodactylinae and Zoantheae. By J. E. DUERDEN, Assoc. R. C. Sc. (Lond.), Curator of the Museum of the Institute of Jamaica. Plates X. to XV. (January, 1900.) 3s.
7. Survey of Fishing Grounds, West Coast of Ireland, 1890-1891. X.—Report on the Crustacea Schizopoda of Ireland. By ERNEST W. L. HOLY, and W. I. BEAUMONT, B.A., Cantab. Plate XVI. (April, 1900.) 1s. 6d.
8. The Action of Heat on the Absorption Spectra and Chemical Constitution of Saline Solutions. By W. N. HARTLEY, F.R.S., Royal College of Science, Dublin. Plates XVII. to XXII. (September, 1900.) 3s. 6d.
9. On the Conditions of Equilibrium of Deliquescent and Hygroscopic Salts of Copper, Cobalt, and Nickel, with respect to Atmospheric Moisture. By W. N. HARTLEY, F.R.S., Honorary Fellow of King's College, London; Professor of Chemistry, Royal College of Science, Dublin. Plates XXIII., XXIV., and XXV. (July, 1901.) 1s.
10. A New Collimating-Telescope Gun-Sight for Large and Small Ordnance. By SIR HOWARD GRUBB, F.R.S., Vice-President, Royal Dublin Society. Plate XXVI. (August, 1901.) 1s.
11. Photographs of Spark Spectra from the Large Rowland Spectrometer in the Royal University of Ireland. Part I. The Ultra-Violet Spark Spectra of Iron, Cobalt, Nickel, Ruthenium, Rhodium, Palladium, Osmium, Iridium, Platinum, Potassium Chromate, Potassium Permanganate, and Gold. By W. E. ADENEY, D.Sc., A.R.C.Sc.I., Curator and Examiner in Chemistry in the Royal University of Ireland, Dublin. Plates XXVII. and XXVIII. (September, 1901.) 1s.
12. Banded Flame-Spectra of Metals. By W. N. HARTLEY, F.R.S., Honorary Fellow of King's College, London; Royal College of Science, Dublin; and HUGH RAMAGE, B.A., A.R.C.Sc.I., St. John's College, Cambridge. Plates XXIX. to XXXIII. (October, 1901.) 1s.
13. Variation: Germinal and Environmental. By J. C. EWART, M.D., F.R.S., Regius Professor of Natural History in the University of Edinburgh. (October, 1901.) 1s.

[APRIL, 1902.]

THE

SCIENTIFIC TRANSACTIONS

OF THE

ROYAL DUBLIN SOCIETY.

VOLUME VII.—(SERIES II.)

---

XIV.

THE RESULTS OF AN ELECTRICAL EXPERIMENT, INVOLVING THE  
RELATIVE MOTION OF THE EARTH AND ETHER, SUGGESTED BY  
THE LATE PROFESSOR FITZGERALD.

BY

FRED. T. TROUTON, D.Sc., F.R.S.,

University Lecturer in Experimental Physics, Trinity College, Dublin.

---

DUBLIN:

PUBLISHED BY THE ROYAL DUBLIN SOCIETY.

WILLIAMS AND NORGATE,

14, HENRIETTA STREET, COVENT GARDEN, LONDON;

20, SOUTH FREDERICK STREET, EDINBURGH: AND 7, BROAD STREET, OXFORD.

PRINTED AT THE UNIVERSITY PRESS, BY PONSONBY AND WELDRICK.

1902.

---

*Price One Shilling.*



[APRIL, 1902.]

THE

SCIENTIFIC TRANSACTIONS

OF THE

ROYAL DUBLIN SOCIETY.

VOLUME VII.—(SERIES II.)

---

XIV.

THE RESULTS OF AN ELECTRICAL EXPERIMENT, INVOLVING THE  
RELATIVE MOTION OF THE EARTH AND ETHER, SUGGESTED BY  
THE LATE PROFESSOR FITZGERALD.

BY

FRED. T. TROUTON, D.Sc., F.R.S.,

University Lecturer in Experimental Physics, Trinity College, Dublin.

---

DUBLIN:

PUBLISHED BY THE ROYAL DUBLIN SOCIETY.

WILLIAMS AND NORGATE,

14, HENRIETTA STREET, COVENT GARDEN, LONDON;

20, SOUTH FREDERICK STREET, EDINBURGH; AND 7, BROAD STREET, OXFORD.

PRINTED AT THE UNIVERSITY PRESS, BY PONSONBY AND WELDRICK

1902.



## XIV.

**THE RESULTS OF AN ELECTRICAL EXPERIMENT, INVOLVING THE RELATIVE MOTION OF THE EARTH AND ETHER, SUGGESTED BY THE LATE PROFESSOR FITZGERALD.** BY FRED. T. TROUTON, D.Sc., F.R.S., University Lecturer in Experimental Physics, Trinity College, Dublin.

(Read NOVEMBER 20, 1901.)

## I.—PROFESSOR FITZGERALD'S ARRANGEMENT.

IN the autumn of 1900 Professor G. F. FitzGerald proposed an electrical experiment, with the object in view of detecting any relative velocity there might be between the Earth and ether.

The method has not up till now been published, except at a meeting of the Dublin University Experimental Science Association last May.

Professor FitzGerald asked me to carry out the proposed experiments. These I began at once, but owing to delays in preparing the apparatus and getting it into working order, only some preliminary determinations were made before his illness and death.

The fundamental idea of the experiment is that a charged electrical condenser, when moving through the ether, with its plates edgeways to the direction of motion, possesses a magnetic field between the plates in consequence of its motion, in accordance with the generally held view that a moving charge is equivalent to an electric current.

The question then naturally arises as to the source supplying the energy required to produce this magnetic field. If we attribute it to the electric generator, say a battery,\* there is no difficulty indeed, as to there being energy enough to do it, for, in general, the energy supplied by a battery when charging a condenser is double that stored in electrostatic strains in the condenser—

$$EQ = \frac{1}{2}EQ + \text{energy lost as heat, etc.}$$

FitzGerald's view, however, was that it would be found to be supplied through there being a mechanical drag on the condenser itself at the moment of charging, very similar to that which would occur were the mass of any body situated on the surface of the Earth to suddenly become greater. Again in discharging, the condenser should experience an impulse of like amount, but now in the opposite or forward direction. To estimate the extent of this blow, suppose a condenser of capacity  $P$  to be moving edgeways through the ether with the velocity  $u$ , and

\* See Part II. of this Paper.

that the density of its charge is  $\sigma$ . Then the magnetic force between the plates which has to be established is  $H = 4\pi\sigma u$ .\* The energy which must be provided to do this is  $T = \frac{\mu}{8\pi} H^2 \times (\text{volume of dielectric})$ . Remembering that  $\sigma = \frac{KE}{4\pi c}$  where  $K$  is the specific inductive capacity,  $E$  the voltage between the plates, and  $c$  their distance apart, and also that the capacity  $P = \frac{K}{4\pi c^2} \times (\text{volume of dielectric})$ , we have  $T = \frac{1}{2} \mu K P E^2 u^2$ .

We had at our disposal a capacity of about 8 mf., which I found was able to stand 1200 volts. When charged with this voltage, on the above supposition, it comes out that it requires about 1 erg to energize the magnetic field when moving edgewise through the ether at the velocity of the Earth round the Sun, that is at 19 miles per second; this, in centimetres per second, being  $u = 10^6$  about. As regards the other quantities we may take  $\mu = 1$ , and for the specific inductive capacity of the paraffined paper of which the condenser was constructed, we may take 2 as a probable estimate, or in electromagnetic measure  $K = 2/v^2$ ,  $v$  being the velocity of light, and equal to  $3 \times 10^{10}$  cm. per second.

Thus we see that, on charging such a condenser, when placed so as to have its plates edgewise to the direction of motion of the Earth round the Sun, it must get from some source or other 1 erg more energy supplied it than it requires when moving flatwise, unless indeed the ether be in some way dragged along with matter and there be no magnetic field. Fitz Gerald's supposition was, as we have seen, that this came through the condenser, receiving a compensating forward jerk or impulse on being charged, transmitted from the Earth through the supports; and he proposed to detect it by suspending the condenser at the end of an arm with a balance-weight on the other side, by means of a wire, as shown diagrammatically in fig. 1 (see opposite page).

It was originally intended to have two condensers, one at each end of the cross arm, the one to be charged at the moment the other was discharged, not only to double the effect, but also to secure a pure torque acting on the wire. This idea had to be abandoned in the final experiment, owing to all the condensers available breaking down under the excessive voltage employed, save only one. A condenser similar to the one used for charging was employed as the balance-weight, so as to preserve symmetry as far as was possible.

\* The moving positive and negative charges on the two plates, that is, moving relatively to the ether, are equivalent to currents running tangentially in opposite directions in the two plates, so that we may take the field as existing only between the plates. If the plates move "flatways," the equivalent currents are in the normal directions, and neutralize each other's magnetic action almost completely.



As the condenser plates lay horizontally, the effect should have been a maximum at twelve o'clock. The experiments were therefore carried out between the hours of eleven and one each day. In order to have the maximum turning effect the arm was placed north and south.

Some preliminary experiments were made with a view of testing if a blow, whose kinetic energy was only 1 erg, could be competent to produce observable effects. This was done by causing a small object to strike against the arrangement.

These proving highly encouraging, apparatus was constructed with the object of enabling the condenser to be charged and discharged continuously by means of clock-work at the intervals corresponding to the free period of swing of the apparatus. In this way any effect produced would cumulate and be made easier of observation.

The complete period of swing was about 60 seconds, so that the charging and discharging followed each other at half these intervals or about 30 seconds. Coincidence between the rate of the clock which drove the commutator and that of the apparatus was most readily effected by increasing or diminishing the moment of inertia of the suspended apparatus, by means of small weights laid on it or removed as required. This coincidence in period was made very perfect.

The source of the current for charging the condenser was a continuous-current dynamo separately excited, capable of supplying a current of  $\frac{1}{2}$  ampère at 1200 volts. Relays were employed for charging and discharging the condenser, as it was found undesirable, being likely to affect the rate of the clock, to allow such heavy sparking as necessarily took place to occur on the clock-driven commutator.

The leads for the charging current were provided by the suspending wire and by a wire which dipped centrally downwards into a mercury cup. A curved mirror was affixed to provide a spot of light on a mm. scale at the distance of 1860 mm.

The method of experimenting was to charge and discharge at proper intervals by means of the synchronous commutator, and to observe if a swing was set up. Another plan sometimes used was to cause the apparatus to have a small swing to

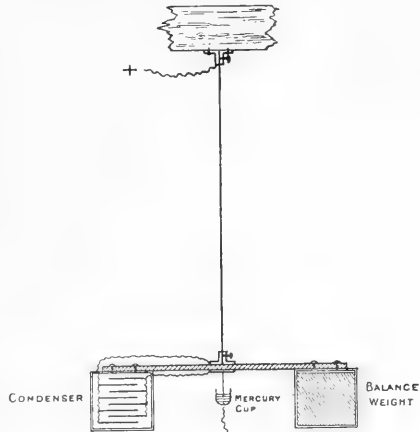

FIG. 1.

begin with, and to see if its rate of decrement was increased by the effect in question when properly timed to do so. No effect was ever observed.

*The Sensitiveness of the Apparatus.*

The method adopted to test the sensitiveness of the apparatus to small quantities of energy, supplied synchronously with its own period, was to place a small magnet on the suspended apparatus at its centre, and to arrange that an intermittent magnetic field was synchronously applied for half the period of swing. The field was applied by means of a circuit of wire placed parallel to the magnet and at one side.

To ascertain the minimum magnetic force competent to set up a swing, the procedure was to gradually reduce the current in this circuit of wire until no effect could be observed on the apparatus at rest, the current all the while being applied at the proper intervals. From this a maximum limit to the value to be assigned to the minimum energy capable of producing a swing may be determined, by calculating the energy given per swing by this minimum field, when the apparatus had reached a swing clearly observable, because when it was swinging through all angles less than this the energy supplied must have been proportionally less. When the suspended apparatus swings through an angle  $\theta$ , the energy supplied is  $MH\theta$ , where  $M$  is the moment of the magnet, and  $H$  the strength of the applied magnetic field. The minimum magnetic field was found to be about  $H = \cdot037$  when employed with a magnet whose moment was  $M = 204$ ; and taking that a movement of the spot of light of 2 mm. could be detected, we get for the angle  $\theta$  the value  $\frac{1}{2} \times 2/1860$ , the scale being 1860 mm. from the mirror. This gives for the energy supplied once in each complete oscillation  $MF\theta = \cdot004$  ergs about. That is to say, we may safely assert that  $\cdot004$  ergs is competent to set up a swing.

We have seen, however, that the energy necessary to generate the magnetic field assumed to exist is as great as one erg, and this was applied and removed in the experiments each half oscillation; so that it is evident that some other source for the energy or some countervailing effect must clearly be looked for.

On the last opportunity I had of discussing the matter with Professor FitzGerald, preliminary experiments had been made giving as far as they went negative results: the final results not being completed till after Science had to deplore the grievous loss it sustained at his death. FitzGerald, on that occasion, made a remark which, as well as I remember, was to the effect that should the negative results then obtained be sustained by further work, he would attribute the non-occurrence of any observable effect to the same general cause as produced the negative results in Michelson and Morley's experiments on the

relative motion of the Earth and the ether by means of the interference of light.

The explanation of this, which he had himself, simultaneously with Lorentz, suggested, was that matter altered in linear dimensions according to the direction of motion through the ether, and to an extent to just neutralize the calculated optical effect. From some such cause a diminution of the electrostatic energy might be brought about when the condenser was in the edge-wise position, just sufficient in amount to provide the energy required for the magnetic field.

## II.—ON THE POSSIBILITY OF OBTAINING A TURNING FORCE FROM THE MOTION OF THE EARTH THROUGH SPACE.

If we suppose the energy for the magnetic field between the plates of a charged condenser when moving “edgewise” through the ether to be supplied from the same source as that which charges the condenser, we are led to the curious conclusion, that a charged condenser tends to set itself flatways to the direction of motion through the ether. This may be easily understood from the following considerations.

A condenser charged when moving “edgewise” has more energy to be supplied it than when moving “flatwise.” Now suppose a condenser which is placed with its plates “flatwise” to the motion through the ether, to be first charged and insulated, then turned round till it is standing with its plates “edgewise” to the motion through the ether. The extra energy belonging to the magnetic field, which we suppose to now exist, must come from work done in turning it round through the  $90^\circ$ . That is to say, the condenser resists with, or exerts, a couple in the opposite direction to the turning motion.

Thus we see, on the assumption made above, that charged condensers must tend to set themselves at right angles to the direction of motion through the ether. When placed exactly “edgeways” to the motion, there is unstable equilibrium; but when inclined to either side, rotation to the position at right angles tends to take place indiscriminately as to the sign of the charges on the plates. This follows at once from the energy of the magnetic field depending on the squares of the directed quantities in question. The value of the torque increases with the angle of inclination, till it reaches its maximum half way between the two positions of “edgeways” and right angles to the motion through the ether, at each of which it is zero. For if  $\phi$  is the angle of inclination of the plates of the condenser to the direction of motion through the ether, the velocity of flow parallel to the plates is  $u \cos \phi$ . Thus the energy of the magnetic field is in this case  $T = \frac{1}{2} \mu K P E^2 u^2 \cos^2 \phi$ , and the couple at any angle  $\phi$  is  $-\frac{dT}{d\phi}$  or  $\frac{1}{2} \mu K P E^2 u^2 \sin 2\phi$ , this obviously has zero value for values  $0^\circ$  and  $90^\circ$ , and a maximum value for  $\phi = 45^\circ$ .

From this point of view, instead of a translatory impulse as suggested by FitzGerald, it is a purely turning effect which should be looked for, and the author proposes to test the matter by suspending a light condenser of very high insulation, with its plates standing vertically. As the effect increases with the square of the voltage, it is advantageous to have this quantity as large as possible. This may be the more readily done in the present case, as the same complications do not present themselves from sparking, etc., as arose where intermittent charging was necessary in the experiments described in the body of this paper. By having the suspended apparatus light, the moment of torsion of the wire may be greatly reduced, which is of the highest importance.

Should this turning moment be proved to operate, instead of being masked by some compensating effect, it would open up a road leading to illimitable possibilities, for it would at once remove from the category of utter hopelessness the idea of mankind ever being able to utilize the vast store of energy in the Earth's motion through space.

It is not difficult in theory to conceive a machine for doing this, in fact for harnessing the solar system, so to speak. For instance, a number of air condensers could be arranged round a cylinder so as to be capable of rotating as a whole about its axis, and spaced with their plates tangentially to their circular motion, the axis of rotation being always kept at right angles to the motion through the ether. Now, suppose one of these condensers to be charged with electricity, as it moves up from the "edgewise" position to the "flatwise" position, there is a couple exerted, turning the whole apparatus round the common axis. On reaching the latter position, the charges on the plates of the condenser are to be conveyed to another of the condensers, which, in the course of its passage round, has just reached the "edgewise" position vacated by the first one in question. This must be effected without sparking, or there would be an undue loss of energy. This might be done by a method very similar to Maxwell's well-known "regenerator" arrangement. As each condenser comes to the "flatwise" position, it enters an inductor arrangement, one for each plate of the condenser, and when fully inside each plate touches a contact spring. Simultaneously a pair of condenser plates at the "edgewise" position is emerging from a pair of inductors, one for each plate, but still kept in metallic contact with the inductors by springs. The inductors in each position are in metallic connexion with the corresponding inductors at right angles. In this way the charge is removed from one set of plates and given to the other. The same could be also used in duplicate on the diametrically opposite position, thus giving double the turning force.

I take this opportunity of thanking Professor J. Larmor, Sec. R.S., for his advice and helpful discussions of the subject-matter of this paper.



## TRANSACTIONS (SERIES II.).

- VOL. I.—Parts 1-25.—November, 1877, to September, 1883.  
VOL. II.—Parts 1-2.—August, 1879, to April, 1882.  
VOL. III.—Parts 1-14.—September, 1883, to November, 1887.  
VOL. IV.—Parts 1-14.—April, 1888, to November, 1892.  
VOL. V.—Parts 1-13.—May, 1893, to July, 1896.  
VOL. VI.—Parts 1-16.—February, 1896, to August, 1898.

### VOLUME VII.

#### PART

1. A Determination of the Wave-lengths of the Principal Lines in the Spectrum of Gallium, showing their Identity with Two Lines in the Solar Spectrum. By W. N. HARTLEY, F.R.S., and HUGH RAMAGE, A.R.C.Sc.I. Plate I. (August, 1898.) 1s.
2. Radiating Phenomena in a Strong Magnetic Field. Part II.—Magnetic Perturbations of the Spectral Lines. By THOMAS PRESTON, M.A., D.Sc., F.R.S. (June, 1899.) 1s.
3. An Estimate of the Geological Age of the Earth. By J. JOLY, M.A., B.A.I., D.Sc., F.R.S., F.G.S., M.R.I.A., Honorary Secretary of the Royal Dublin Society; Professor of Geology and Mineralogy in the University of Dublin. (November, 1899.) 1s. 6d.
4. On the Electrical Conductivity and Magnetic Permeability of various Alloys of Iron. By W. F. BARRETT, F.R.S.; W. BROWN, B.Sc.; R. A. HADFIELD, M.Inst.C.E. Plates II. to IX. (January, 1900.) 4s.
5. On some Novel Thermo-Electric Phenomena. By W. F. BARRETT, F.R.S., Professor of Experimental Physics in the Royal College of Science for Ireland. Plate IXA. (January, 1900.) 1s.
6. Jamaican Actinaria. Part II.—Stichodactylinae and Zoantheae. By J. E. DUERDEN, Assoc. R. C. Sc. (Lond.), Curator of the Museum of the Institute of Jamaica. Plates X. to XV. (January, 1900.) 3s.
7. Survey of Fishing Grounds, West Coast of Ireland, 1890-1891. X.—Report on the Crustacea Schizopoda of Ireland. By ERNEST W. L. HOLT, and W. I. BEAUMONT, B.A., Cantab. Plate XVI. (April, 1900.) 1s. 6d.
8. The Action of Heat on the Absorption Spectra and Chemical Constitution of Saline Solutions. By W. N. HARTLEY, F.R.S., Royal College of Science, Dublin. Plates XVII. to XXII. (September, 1900.) 3s. 6d.
9. On the Conditions of Equilibrium of Deliquescent and Hygroscopic Salts of Copper, Cobalt, and Nickel, with respect to Atmospheric Moisture. By W. N. HARTLEY, F.R.S., Honorary Fellow of King's College, London; Professor of Chemistry, Royal College of Science, Dublin. Plates XXIII., XXIV., and XXV. (July, 1901.) 1s.
10. A New Collimating-Telescope Gun-Sight for Large and Small Ordnance. By SIR HOWARD GRUBB, F.R.S., Vice-President, Royal Dublin Society. Plate XXVI. (August, 1901.) 1s.
11. Photographs of Spark Spectra from the Large Rowland Spectrometer in the Royal University of Ireland. Part I. The Ultra-Violet Spark Spectra of Iron, Cobalt, Nickel, Ruthenium, Rhodium, Palladium, Osmium, Iridium, Platinum, Potassium Chromate, Potassium Permanganate, and Gold. By W. E. ADENEY, D.Sc., A.R.C.Sc.I., Curator and Examiner in Chemistry in the Royal University of Ireland, Dublin. Plates XXVII. and XXVIII. (September, 1901.) 1s.
12. Banded Flame-Spectra of Metals. By W. N. HARTLEY, F.R.S., Honorary Fellow of King's College, London; Royal College of Science, Dublin; and HUGH RAMAGE, B.A., A.R.C.Sc.I., St. John's College, Cambridge. Plates XXIX. to XXXIII. (October, 1901.) 1s.
13. Variation: Germinal and Environmental. By J. C. EWART, M.D., F.R.S., Regius Professor of Natural History in the University of Edinburgh. (October, 1901.) 1s.
14. The Results of an Electrical Experiment, involving the Relative Motion of the Earth and Ether, suggested by the late Professor Fitz Gerald. By FRED. T. TROUTON, D.Sc., F.R.S., University Lecturer in Experimental Physics, Trinity College, Dublin. (April, 1902.) 1s.

[MAY, 1902.]

THE  
SCIENTIFIC TRANSACTIONS  
OF THE  
ROYAL DUBLIN SOCIETY.

VOLUME VII.—(SERIES II.)

---

XV.

SOME NEW FORMS OF GEODETICAL INSTRUMENTS.

BY

SIR HOWARD GRUBB, F.R.S.,  
Vice-Pres. Royal Dublin Society.

(PLATE XXXIV.)

---

DUBLIN:  
PUBLISHED BY THE ROYAL DUBLIN SOCIETY.  
WILLIAMS AND NORGATE,  
14, HENRIETTA STREET, COVENT GARDEN, LONDON;  
20, SOUTH FREDERICK STREET, EDINBURGH; AND 7, BROAD STREET, OXFORD.  
PRINTED AT THE UNIVERSITY PRESS, BY PONSONBY AND WELDRICK.  
1902.

---

*Price One Shilling.*





## INDEX SLIP.

---

GRUBB, SIR HOWARD.—Some New Forms of Geodetical Instruments.  
Roy. Dublin Soc. Trans., 2, vol. 7, 1898-1902, pp. 385-390.

Geodetical Instruments ; some New Forms of.  
Grubb, Sir Howard.  
Roy. Dublin Soc. Trans., 2, vol. 7, 1898-1902, pp. 385-390.

INDEX SLIP.

Geological instruments: with New forms of.  
Gardner, Sir Howard.  
Royal Dublin Soc. Trans., 3, vol. 7, 1862-1863, pp. 329-330.

Geological instruments: with New forms of.  
Gardner, Sir Howard.  
Royal Dublin Soc. Trans., 3, vol. 7, 1862-1863, pp. 329-330.

[MAY, 1902.]

THE

SCIENTIFIC TRANSACTIONS

OF THE

ROYAL DUBLIN SOCIETY.

VOLUME VII.—(SERIES II.)

---

XV.

SOME NEW FORMS OF GEODETICAL INSTRUMENTS.

BY

SIR HOWARD GRUBB, F.R.S.,

Vice-Pres. Royal Dublin Society.

(PLATE XXXIV.)

---

DUBLIN:

PUBLISHED BY THE ROYAL DUBLIN SOCIETY.

WILLIAMS AND NORGATE,

14, HENRIETTA STREET, COVENT GARDEN, LONDON;

20, SOUTH FREDERICK STREET, EDINBURGH; AND 7, BROAD STREET, OXFORD.

PRINTED AT THE UNIVERSITY PRESS, BY PONSONBY AND WELDRICK.

1902.



XV.

SOME NEW FORMS OF GEODETICAL INSTRUMENTS.

By SIR HOWARD GRUBB, F.R.S., Vice-President Royal Dublin Society.

(PLATE XXXIV.)

[Read DECEMBER 18, 1901.]

THE principles involved in the gun-sighting apparatus described in a paper of mine read before the Royal Dublin Society, March 20th, 1901, and published in the *Scientific Transactions*, vol. VII., series II., are applicable to all instruments used for observing the direction or bearings of distant objects, more especially for surveying and geodetical instruments of almost every variety.

In the present paper I propose to describe how these principles can be utilized in the case of some of the simpler and best known surveying instruments, such as the Plane Table or Graphometer, the Level, the Prismatic Compass, and the Clinometer.

Referring for a moment to the above paper on the gun-sighting apparatus, it will be observed that by a simple optical contrivance a virtual or "ghost" image of a cross, or any similar device, is seen as if projected on to the object aimed at. This image is formed on the same plane as the object itself; there is therefore no parallax and no necessity for any backsight, and the aiming of the weapon is effected by the simple superposition of the cross and object, both of which can be seen distinctly without any straining or re-focussing of the eyes such as is the case when using the ordinary sights.

**Description.**—The original conception of this sight, as described in the paper above referred to, is represented in fig. 1. The object to be aimed at is viewed through a short piece of tube (*AB*) preferably square, open at both ends, in which is mounted, at an angle of  $45^\circ$ , a plate or plates of parallel glass, similar to those used in sextants.

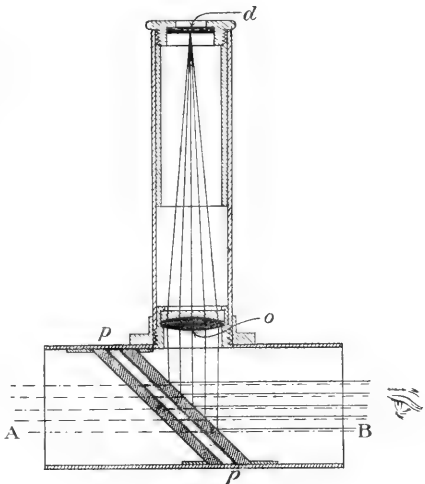

FIG. 1.

At right angles to this tube is mounted a smaller tube carrying at its outer end a diaphragm (*d*), preferably of glass coated with some opaque material, through which lines are cut representing a cross, star, circle, or any other desired device.

At the base of this same tube, near its junction with the main or sighting tube, is placed an achromatic lens, the distance between the diaphragm and the achromatic lens being equal to the principal focus of that lens; consequently rays of light from the sky or any other source of light which pass through the transparent portion of the diaphragm, diverge until they reach this object-glass (*o*), and are by it rendered parallel, and are reflected by the diagonal plate or plates, *pp*, once again as parallel rays, into the eye of the observer; the result being that the observer sees, superposed upon the object he is aiming at, an image (generally called a "virtual" image) of the cross or device cut upon the diaphragm; and inasmuch as the arrangement, when properly adjusted, is such that the rays from the diaphragm enter the eye under exactly the same conditions as if from the distant object, the cross appears not only superposed on the object, but at the same distance as the object itself. As a consequence of this, the cross is seen absolutely sharp with the same focussing of the eye as that necessary for viewing the distant object, and there is no straining of the eye to see both in focus at the same time; also it follows that there is no parallax, that is to say, that the cross and the object aimed at, if made to coincide when the eye is in the centre of the tube, will equally well coincide no matter what portion of the sighting tube the eye is placed opposite to; in other words, there is no necessity for the observer to keep his eye in any fixed position.

It will be noticed in this instrument that three plates of glass are shown superposed upon one another for reflecting the image of the device on the diaphragm into the eye:—The object of this is to intensify the brilliancy of the reflected image without sensibly diminishing the apparent brilliancy of the object aimed at. Later on, however, it was found that a more practical plan of increasing this brilliancy was to use one single piece of glass, and coat this with a semi-transparent and highly reflective film. A long series of experiments carried out by Professor J. Emerson Reynolds, F.R.S., and Mr. G. Rudolf Grubb, B.A.I., resulted in a modification of a process invented by the former by which the desired film was obtained.

It will be seen that there are two distinct principles involved in this instrument.

(1). The complete absence of parallax is obtained by the employment of the collimating lens "O," which brings into parallelism the rays proceeding from the small cross at "D," so that these rays enter the eye under exactly the same conditions as they would if proceeding from a large cross at a great distance, instead of a small cross at a small distance.

(2). The superposition of this image of the cross and that of the object is obtained by the use of the semi-transparent and semi-reflective film chemically

deposited on the surface of the inclined glass (see p. 326 of the above-mentioned paper on the gun-sights).

The same effect as this last (superposition of two images) is produced in many well-known instruments by a different device, viz., by utilizing one-half the pupil of the eye for forming one image on the retina, and the other half of the pupil for forming the other image on the retina. This is used in such instruments as the Sextant, and by it observations of this superposition class (the only reliable observations that can be made on ship-board) are rendered possible. But there are some objections to this plan—the eye requiring to be held very precisely in one fixed position, the observations are difficult for an inexperienced person, and at the best they are eye-teasing and troublesome.

By the use of the semi-transparent and semi-reflective films these objections are removed. There is no necessity for fixity of the observer's eye, and there is no strain whatever in viewing the two objects and bringing them into coincidence.

In one point only does it appear that the old plan of "dividing the pupil" has any advantage, and that is in the possibility of varying the relative brilliancy of the images by moving the eye slightly up and down so that more or less of the area of the pupil is used in forming one or other image. This advantage, however, does not compensate for the disadvantages which necessarily accompany it, as mentioned just now.

It is not claimed that these instruments will ever supplant the standard geodetical instruments, such as the Level and Theodolite, for their own legitimate work, but those who have had experience in this line know that Theodolites and Levels are often used for work for which they are not suitable, and in which their accuracy and delicacy is not only wasted but is a positive disadvantage, and they are used for this work only because there is nothing simpler available.

It is for such work that I have designed these instruments. By their use rapid surveys can be made by comparatively uneducated and inexperienced hands, and with an accuracy as great as can be attained in plotting the survey on paper.

For all ordinary surveying work, such as is necessary for road making, railway making, and property-conveyancing purposes, the ultimate amount of accuracy possible of attainment is limited to that with which the survey can be plotted upon paper, practically the breadth of a pencil line.

In the usual methods of surveying, the survey is plotted upon the paper either from dimensions taken with the chain or angles measured with the Theodolite, or both; but no matter how accurately these measures of distance and angles are taken, the ultimate accuracy of the survey cannot exceed that above stated.

With these new instruments bearings can be registered with a probable error of less than two minutes of arc.\* This, in most cases, will be represented upon

\* According to most text-books an accuracy of a minute of arc should be obtainable.

paper by a quantity less than the breadth of a pencil line. It is evident, therefore, that the accuracy obtainable by this method is as great in most cases as can be recorded upon the paper. The system is very much more direct and rapid, the plotting upon the paper being effected directly from the sighting observations, whereas, in the case of the Theodolite, the angles have to be measured and noted down and then laid off again on the paper with another instrument of the form of a protractor. So far as the ultimate survey is concerned there is no use in noting these angles except as a means to an end, the final result being the plotted survey, which, by the new method, is done directly and without the measurement of any angles.

Instruments of this class are capable of doing good work in the hands of comparatively inexperienced observers, for it is not necessary that the manipulators of these instruments should understand anything about angles at all, or be able to read verniers, and the process being a direct one, instead of one that is the result of a series of observations and steps, the risk of error is very much lessened.

**Plane Table.**—The Plane Table, as adapted for the new form of sight, is shown diagrammatically in fig. 2, and in use in Pl. xxxiv., fig. 5. It consists, as usual, of a levelled drawing-board, covered with a sheet of paper, on which it is desired to plot a survey, a base (which may be of any desired form, but which in this case, for reasons of convenience, partakes of the form of a set square), and a sharp steel pin which can be inserted in the drawing-board to form a centre for the whole of this base to turn upon, and on this base one of the new sights.

If the instrument is to be used as a Plane Table and for taking bearings simply, it is only necessary to have projected on the object a single vertical line.

By superposing this upon the staff at the different salient points of the survey the bearing of each object can be recorded upon the paper, and when this is completed the whole Plane Table can be moved to another position with a measured base line between the two, and angles taken over again from this second station as at the first, the intersection of the two sets of bearings giving a record of the points required of the survey.

If, however, the area to be surveyed is small, and it be required to use the

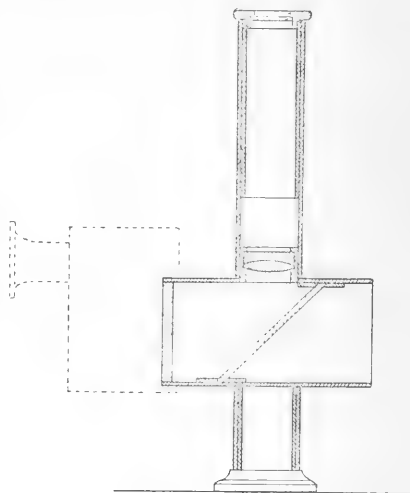

FIG 2



instrument as a subtense instrument, and to complete the survey from one single point, it is necessary to project upon the staff a scale, as is seen to be the case in the engraving, Pl. xxxiv., fig. 6. The staff used in this case has two marks placed upon it a certain distance apart, say two yards, and at the same time that the bearing of that staff is taken (as in the operation first described for the Plane Table) the interval between those two marks, six feet apart on the staff, is measured by the number of divisions which that space occupies on that scale, the number of the divisions occupied by this space being of course greater as the distance of the staff is less, and *vice versa*.

On that side of the base which is parallel to the line of sight, and which points also to the centre on which the base revolves, a scale of unequal parts is cut, and if a mark be made at the particular division on this base scale, which corresponds to the number of the divisions occupied by the staff on the "ghost" scale as seen in the sight, that point will represent on the paper not only the bearing of that staff as regards the central station, but the actual distance from it, according to whatever scale the instrument is divided for.

The assistant carrying the staff is directed to walk round the field and plant his staff at every spot where a change in the direction of the boundary occurs, holding the staff upright until the observer signals to him to pass to the next station, and in this way a survey can be completed upon the paper in the time that it takes the assistant to pass round the field from station to station.

**Level.**—The Level, with the new sight applied, is shown diagrammatically in plan in fig. 3, and as worked in Pl. xxxiv., fig. 8. It is not intended that this Level should be used to supplant the ordinary surveyor's level with the parallel plates, &c., but it is intended to take the place of the class of instrument generally known as the "Abney" level, which is held in the hand, and which is very rapid in its working, giving fair results, and sufficient for ordinary road work, or laying out of grounds.

In this instrument the sight is utilized for projecting upon the field of view not only a fiducial mark, but an image of the bubble itself, and also that of an arc, which shows the gradient to which the instrument is set when it is necessary to lay off roads or bases that are any particular number of degrees off the horizontal.

The appearance of the field of view is shown in Pl. xxxiv., fig. 7, where the instrument has been set for a level gradient, and it will be seen that the observer

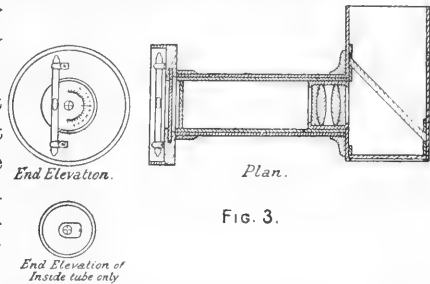

FIG. 3.

can satisfy himself that he is holding the instrument level by watching the position of the bubble, at the same time that he ascertains the coincidence of the fiducial line and the reading of the staff, while the gradient shown in the upper part of the field is read off on the circular arc.

If desired for more accurate work, such instruments can be mounted upon parallel plates and tripod stand, but it is in rapid work of an approximate character that it bears such a favourable comparison with the existing forms.

**Prismatic Compass.**—A section of the Prismatic Compass, with the new sight attached, is shown in fig. 4, and the instrument is shown in use in Pl. xxxiv., fig. 9. In this case the only alteration, so far as the compass box is concerned, is that it is desirable to have the card printed upon a transparent substance such as celluloid, and with transparent lines and figures upon a black ground. This enables the full light from the sky to be utilized, and the divisions of the card are then seen projected perfectly sharply on the object, whose magnetic bearing it is desired to ascertain.

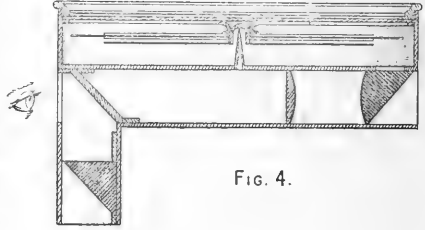

FIG. 4.

There is, however, in this compass a peculiar feature of special importance. It will be observed that there is no fiducial line whatever, nor is this necessary, because the instrument is so constructed that the degree divisions upon the card are seen projected upon the object, representing actual degrees upon the horizon, as seen from the observer's station. Therefore when the card is stationary the bearing of every object in the field corresponds to the particular division on the card which superposes on it, whether that object be in the centre or at the sides of the field. This feature is of very great importance as it simplifies the observations considerably. In the ordinary way it is necessary to make two coincidences, first, between the very indistinctly seen thread and the object, which is itself also indistinct, and secondly, between the indistinctly seen thread and the compass card; whereas in this new form there is only one coincidence required to be made, that between the object itself and the division on the card, both of which can be seen absolutely sharp at the same time.

A Clinometer on this principle is of essentially the same construction as the Prismatic Compass, except that the compass card and magnetic needle are replaced by a divided circle or arc weighted at one point, and that the instrument is held with the box in a vertical instead of a horizontal plane. This constitutes a clinometer of very convenient form.

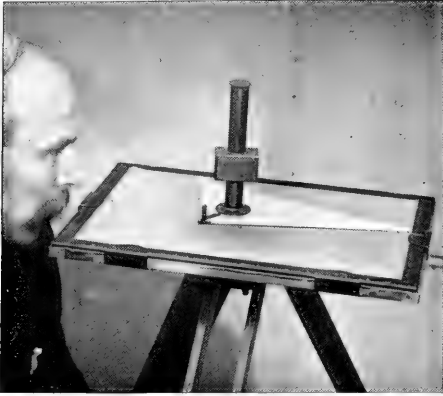

FIG. 5.—Photograph of Plane Table or Graphometer in use.



FIG. 6.—Scale and View photographed through instrument shown in Fig. 5.

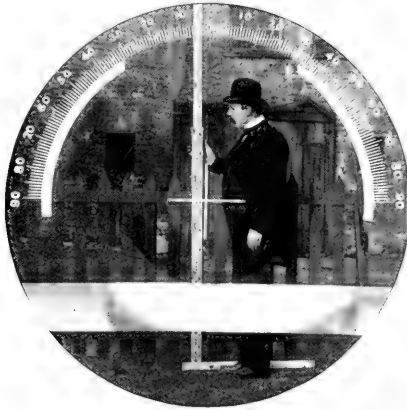

FIG. 7.—Staff, Cross, Scale, and Level Bubble, photographed through instrument shown in Fig. 8.



FIG. 8.—Photograph of Hand Level in use.



FIG. 9.—Photograph of Prismatic Compass in use.





## TRANSACTIONS (SERIES II.).

VOL. I.—Parts 1-25.—November, 1877, to September, 1883.

VOL. II.—Parts 1-2.—August, 1879, to April, 1882.

VOL. III.—Parts 1-14.—September, 1883, to November, 1887.

VOL. IV.—Parts 1-14.—April, 1888, to November, 1892.

VOL. V.—Parts 1-13.—May, 1893, to July, 1896.

VOL. VI.—Parts 1-16.—February, 1896, to August, 1898.

### VOLUME VII.

PART

1. A Determination of the Wave-lengths of the Principal Lines in the Spectrum of Gallium, showing their Identity with Two Lines in the Solar Spectrum. By W. N. HARTLEY, F.R.S., and HUGH RAMAGE, A.R.C.Sc.I. Plate I. (August, 1898.) 1s.
2. Radiating Phenomena in a Strong Magnetic Field. Part II.—Magnetic Perturbations of the Spectral Lines. By THOMAS PRESTON, M.A., D.Sc., F.R.S. (June, 1899.) 1s.
3. An Estimate of the Geological Age of the Earth. By J. JOLY, M.A., B.A.I., D.Sc., F.R.S., F.G.S., M.R.I.A., Honorary Secretary of the Royal Dublin Society; Professor of Geology and Mineralogy in the University of Dublin. (November, 1899.) 1s. 6d.
4. On the Electrical Conductivity and Magnetic Permeability of various Alloys of Iron. By W. F. BARRETT, F.R.S.; W. BROWN, B.Sc.; R. A. HADFIELD, M.Inst.C.E. Plates II. to IX. (January, 1900.) 4s.
5. On some Novel Thermo-Electric Phenomena. By W. F. BARRETT, F.R.S., Professor of Experimental Physics in the Royal College of Science for Ireland. Plate IXA. (January, 1900.) 1s.
6. Jamaican Actinaria. Part II.—Stichodactylinae and Zoantheae. By J. E. DUERDEN, Assoc. R. C. Sc. (Lond.), Curator of the Museum of the Institute of Jamaica. Plates X. to XV. (January, 1900.) 3s.
7. Survey of Fishing Grounds, West Coast of Ireland, 1890-1891. X.—Report on the Crustacea Schizopoda of Ireland. By ERNEST W. L. HOLT, and W. I. BEAUMONT, B.A., Cantab. Plate XVI. (April, 1900.) 1s. 6d.
8. The Action of Heat on the Absorption Spectra and Chemical Constitution of Saline Solutions. By W. N. HARTLEY, F.R.S., Royal College of Science, Dublin. Plates XVII. to XXII. (September, 1900.) 3s. 6d.
9. On the Conditions of Equilibrium of Deliquescent and Hygroscopic Salts of Copper, Cobalt, and Nickel, with respect to Atmospheric Moisture. By W. N. HARTLEY, F.R.S., Honorary Fellow of King's College, London; Professor of Chemistry, Royal College of Science, Dublin. Plates XXIII., XXIV., and XXV. (July, 1901.) 1s.
10. A New Collimating-Telescope Gun-Sight for Large and Small Ordnance. By SIR HOWARD GRUBB, F.R.S., Vice-President, Royal Dublin Society. Plate XXVI. (August, 1901.) 1s.
11. Photographs of Spark Spectra from the Large Rowland Spectrometer in the Royal University of Ireland. Part I. The Ultra-Violet Spark Spectra of Iron, Cobalt, Nickel, Ruthenium, Rhodium, Palladium, Osmium, Iridium, Platinum, Potassium Chromate, Potassium Permanganate, and Gold. By W. E. ADENEY, D.Sc., A.R.C.Sc.I., Curator and Examiner in Chemistry in the Royal University of Ireland, Dublin. Plates XXVII. and XXVIII. (September, 1901.) 1s.
12. Banded Flame-Spectra of Metals. By W. N. HARTLEY, F.R.S., Honorary Fellow of King's College, London; Royal College of Science, Dublin; and HUGH RAMAGE, B.A., A.R.C.Sc.I., St. John's College, Cambridge. Plates XXIX. to XXXIII. (October, 1901.) 1s.
13. Variation: Germinal and Environmental. By J. C. EWART, M.D., F.R.S., Regius Professor of Natural History in the University of Edinburgh. (October, 1901.) 1s.
14. The Results of an Electrical Experiment, involving the Relative Motion of the Earth and Ether, suggested by the late Professor Fitz Gerald. By FRED. T. TROUTON, D.Sc., F.R.S., University Lecturer in Experimental Physics, Trinity College, Dublin. (April, 1902.) 1s.
15. Some New Forms of Geodetical Instruments. By SIR HOWARD GRUBB, F.R.S., Vice-Pres. Royal Dublin Society. Plate XXXIV. (May, 1902.) 1s.

[MAY, 1902.]

THE  
SCIENTIFIC TRANSACTIONS  
OF THE  
ROYAL DUBLIN SOCIETY.

VOLUME VII.—(SERIES II.)

---

XVI.

SOME SEDIMENTATION EXPERIMENTS AND THEORIES.

BY

J. JOLY, D.Sc., F.R.S., F.G.S.,

Honorary Secretary R.D.S., Professor of Geology and Mineralogy,  
Trinity College, Dublin.

---

DUBLIN:  
PUBLISHED BY THE ROYAL DUBLIN SOCIETY.  
WILLIAMS AND NORGATE,  
14, HENRIETTA STREET, COVENT GARDEN, LONDON;  
20, SOUTH FREDERICK STREET, EDINBURGH; AND 7, BROAD STREET, OXFORD.  
PRINTED AT THE UNIVERSITY PRESS, BY PONSONBY AND WELDRICK.  
1902.

*Price One Shilling.*





INDEX SLIP.

---

JOLY, J.—Some Sedimentation Experiments and Theories.  
Roy. Dublin Soc. Trans., 2, vol. 7, 1898-1902, pp. 391-402.

Sedimentation Experiments and Theories.  
Joly, J.  
Roy. Dublin Soc. Trans., 2, vol. 7, 1898-1902, pp. 391-402.

1207Z 2110

1207Z 2110 - 1207Z 2110 - 1207Z 2110

1207Z 2110 - 1207Z 2110 - 1207Z 2110

[MAY, 1902.]

THE

SCIENTIFIC TRANSACTIONS

OF THE

ROYAL DUBLIN SOCIETY.

VOLUME VII.—(SERIES II.)

---

XVI.

SOME SEDIMENTATION EXPERIMENTS AND THEORIES.

BY

J. JOLY, D.Sc., F.R.S., F.G.S.,

Honorary Secretary R.D.S., Professor of Geology and Mineralogy,  
Trinity College, Dublin.

---

DUBLIN:

PUBLISHED BY THE ROYAL DUBLIN SOCIETY.

WILLIAMS AND NORGATE,

14, HENRIETTA STREET, COVENT GARDEN, LONDON;

20, SOUTH FREDERICK STREET, EDINBURGH; AND 7, BROAD STREET, OXFORD.

PRINTED AT THE UNIVERSITY PRESS, BY PONSONBY AND WELDRICK.

1902.

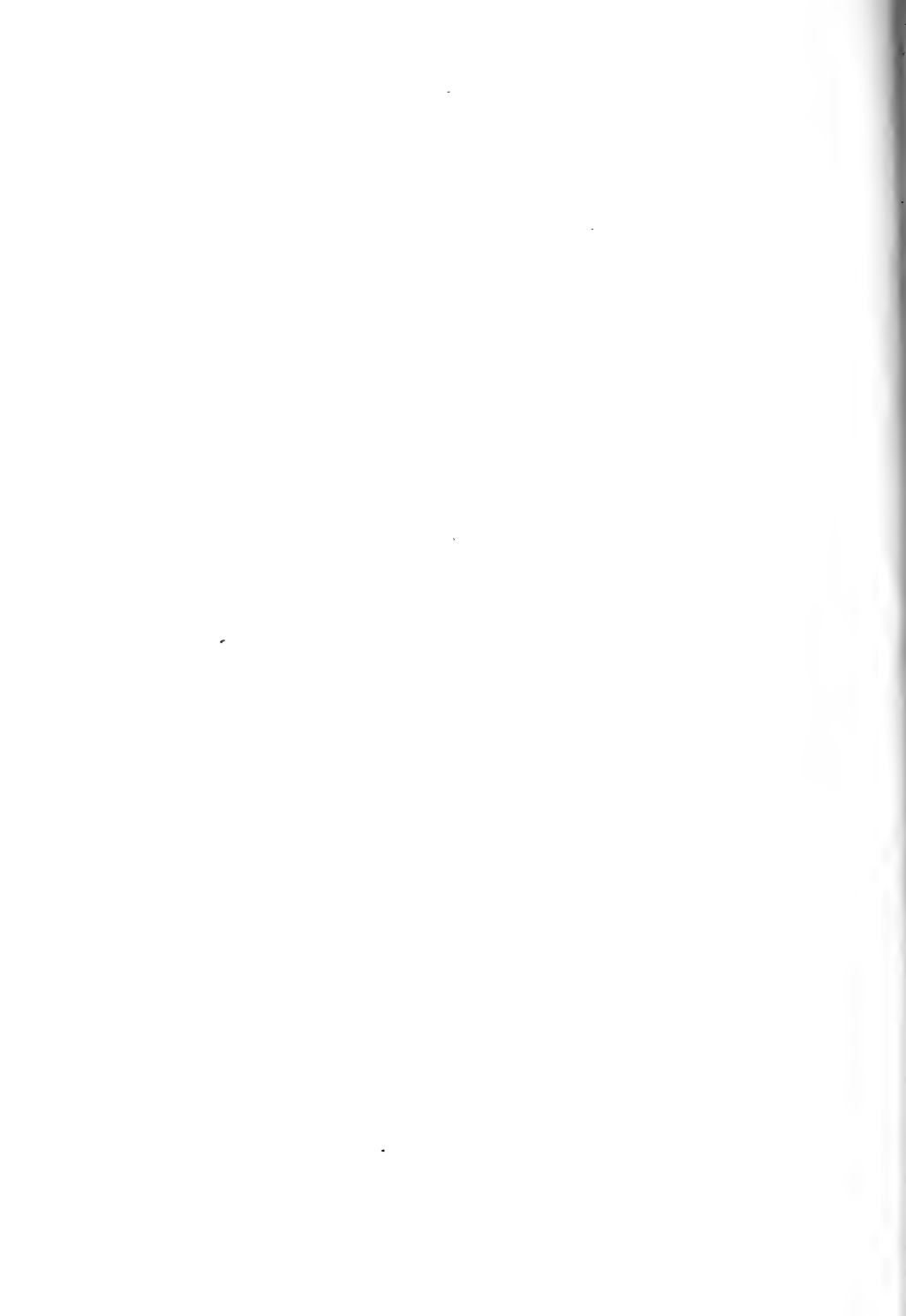

## XVI.

## SOME SEDIMENTATION EXPERIMENTS AND THEORIES.

BY J. JOLY, D.Sc., F.R.S., F.G.S.,

Honorary Secretary R.D.S., Professor of Geology and Mineralogy, Trinity College, Dublin.

[Read, DECEMBER 18, 1901.]

IN a Note read before this Society\* and in a Paper read before the Geological Congress of Paris, 1900 (which has not yet appeared),† I described experiments upon very fine and attenuated sediments, such as remain suspended some eighteen hours in distilled water. It appeared from the observations on the effects of various ions in precipitating such suspensions that an approximately similar connexion exists between the ionic valency and the precipitating effectiveness as obtains in the case of colloidal particles, as determined by the experiments and investigations of Messrs. Linder and Picton,‡ Hardy,§ and Whetham.||

There was, furthermore, a remarkable efficiency found to obtain in the case of extremely dilute aluminium salts, not falling into line with previously observed facts. An attempt to connect the experimental results with the double electric layers supposed on other grounds to exist at the boundary of the particles and the liquid is outlined in the same paper.

The present experiments cover somewhat different ground.

Five grammes of a fine silt (in the following experiments this was obtained by reducing Welsh roofing-slate to powder), so fine that the largest particles pass freely through meshes 0.0025 m.m. in dimension (edge of the square) are placed in a test tube about 15 c.ms. in length and 1.3 c.ms. diameter; and 12 c.cs. of a solution of a salt are poured in. After shaking so as to distribute the

\* "On the Inner Mechanism of Sedimentation" (Preliminary Note).—*Scient. Proc. R. D. S.*, vol. IX., p. 325.

† *Comptes Rendus de la viii<sup>e</sup> session, Deuxième fasciende*, p. 710. (Note in the press.)

‡ *Chemical Soc. Journ.*, vol. 67, 1895, p. 63.

§ *Proc. Roy. Soc.*, vol. 66, p. 110.

|| *Phil. Mag.*, v. 48, 1899, p. 74.

silt through the liquid it is allowed to stand. The phenomena now observed, attending the settlement of the silt, will depend upon the concentration and valency of the ions present. If above a certain concentration for the valency of the positive ion present, there appears in less than a minute a bounding surface to the silt beneath the meniscus of the liquid; perhaps a millimetre beneath; which momentarily continues to sink, attaining at the end of ten minutes a depression of about 1.2 c.ms., the liquid above being nearly limpid. At the expiration of twenty minutes from starting the surface will have fallen to about 2.6 c.ms.; after thirty minutes to 3.5 or thereabouts; the rate of descent is often now further increased so that in forty minutes it reaches about 5.5 c.ms. If observations are carried on for a further ten minutes generally a rapid convergence in the rate is observed due to the crowding of the sediment towards the bottom of the tube. At the fiftieth minute 6.2 c.ms. about may be reached.

If this experiment be repeated with diminishing strengths of solutions, but always using the same quantities of silt and liquid, the rate of fall of the surface will be found well maintained, but it will be observed that with small concentrations the limpid appearance of the liquid above the sediment, and which is so remarkable a feature of the experiments at high concentrations, gradually disappears. At successively decreasing concentrations this supernatant liquid assumes a more and more milky and turbid appearance; passing from a nearly limpid appearance to the translucency which paraffin wax might show and finally to that of tallow. The final stage of the phenomena being the complete disappearance of all boundary between sediment and liquid. This stage is reached at a degree of dilution which depends on the valency of the metallic ion, as will be seen, and until it is reached the rate of descent of the visible upper boundary of the sediment is fairly well maintained. But, as must be obvious, the sediment sinking at this standard rate (as I may call it) is of a coarser character at the lower concentrations of the electrolyte, the turbidity of the overlying liquid being due to the continued suspension of the finer particles. At such low concentrations the ions possess in fact a remarkable sorting effect, allowing the finer sediment to remain so long in solution that when, in course of time, this too sinks to the bottom, it rests as a sharply differentiated layer upon the sediment first deposited. The stronger concentrations of salt solutions, leaving a clear liquid above, cause all to fall together, and although there is some sorting of the largest particles, those being most affected by gravity, there is no sharp line of demarcation in the final sediment. Every intermediate stage between this almost perfect intermingling of the particles of various sizes, and the very marked separation obtained when a distinct upper surface to the falling sediment completely fails, of course exists.

The final disappearance of the upper boundary is thus not a suddenly attained state, but is reached by a gradual delay in the precipitation of the finer particles. This is also revealed in the fact that before final disappearance this boundary appears first at points which are ever lower in the tube and at stages in the settlement correspondingly advanced; also with increasing indistinctness.

If a sediment which has settled under the action of a strongly concentrated salt be again shaken up, the phenomena first observed are repeated. There may be a small decrease in the rate of descent of the bounding surface. On again shaking up, the rate may show a further very small but distinct decrease. Finally the rate becomes apparently constant and a little less than the initial rate. If, however, the experiment of re-distributing a sediment be tried in the case of concentrations approximating to those which fail to produce a bounding surface, say to such as on first settlement leave the supernatant liquid so turbid as to give it a tallow-like opacity, then the interesting fact is revealed that on second or third shaking the boundary may utterly fail although distinctly produced on first settlement. There has, in fact, occurred some loss of effectiveness of the ions or change in the properties of the suspension, which forbids the repetition of the first effect. With each re-disturbance of the sediment the ionic action is less marked. Finally, the tube may be almost indistinguishable in its behaviour from one containing only silt and distilled water.

Table I. contains experiments on the rate of falling of the sediment-surface in presence of a monad metallic ion at various concentrations, and after successive redistributions of the sediment. The sign (?) indicates that no sediment-surface was distinguishable. It will be seen that at concentrations of 0.007 gram. equivs. per litre the obliteration of a surface of settlement occurred upon second and third settlements.

[TABLE I.

TABLE I.

RATE OF COMPACTING.

5 Grammes Slate Powder in 12 c.cs. Liquid.

	Minutes from Commencement of Settlement.	Depression of Surface of Sediment in c.ms.			Appearance of Liquid above Sediment.
		First Settlement.	Second Settlement.	Third Settlement.	
NaCl 0.90 gramme equivalents per litre.	10	1.3	1.1	0.9	Nearly limpid.
	20	2.6	2.2	2.1	
	30	3.6	3.2	3.0	
	40	5.6	4.2	4.2	
NaCl 0.45 gramme equivalents.	10	1.3	1.1	0.9	As above.
	20	2.7	2.3	2.15	
	30	3.6	3.4	3.2	
	40	5.7	4.5	4.4	
NaCl 0.225 gramme equivalents.	10	1.4	1.1	0.9	As above.
	20	2.8	2.3	2.1	
	30	3.9	3.4	3.2	
	40	5.9	4.4	4.3	
NaCl 0.112 gramme equivalents.	10	1.2	1.0	0.8	Not quite so limpid as the above.
	20	2.3	2.0	1.8	
	30	3.1	2.9	2.7	
	40	5.2	3.9	3.7	
NaCl 0.056 gramme equivalents.	10	1.2	1.0	0.9	A little less translucent than last.
	20	2.6	1.9	1.9	
	30	3.7	2.8	2.7	
	40	—	4.0	3.7	
NaCl 0.028 gramme equivalents.	10	1.1	0.8	0.9	About as translucent as paraffin wax.
	20	2.2	1.7	1.8	
	30	3.2	2.6	2.5	
	40	—	3.6	3.3	
NaCl 0.014 gramme equivalents.	10	1.2	1.1	0.9	Muddy, but more translucent than tallow.
	20	2.6	2.0	1.9	
	30	3.7	3.0	2.8	
	40	—	4.2	3.7	
NaCl 0.007 gramme equivalents.	10	1.1	(?)	(?)	Very muddy, appearance of tallow.
	20	2.2	2.0 (?)	(?)	
	30	3.2	3.0 (?)	(?)	
	40	—	4.0	(?)	

Table II. shows that a diad positive ion is more effective than a monad positive ion; producing not only a slightly increased rate of settlement but preserving a sediment-surface under conditions when the monad ion would prove ineffective.



TABLE II.  
RATE OF COMPACTING. — INFLUENCE OF VALENCY.

*5 Grammes Slate Powder in 12 c.cs. Liquid.*

	Minutes from Commencement of Settlement.	Depression of Surface of Sediment in c.ms.			Appearance of Liquid above Sediment.
		First Settlement.	Second Settlement.	Third Settlement.	
MgCl <sub>2</sub> 0·01 gramme equivalents.	10	1·5	1·2	1·1	Nearly limpid.
	20	2·9	2·5	2·3	
	30	4·6	3·8	3·6	
	40	5·7	5·2	4·8	
	50	5·9	5·6	5·5	
MgCl <sub>2</sub> 0·005 gramme equivalents.	10	1·3	1·2	1·1	More translucent than paraffin wax.
	20	2·8	2·1	2·1	
	30	4·1	3·1	3·1	
	40	5·6	4·1	4·1	
	50	6·1	5·3	5·0	
NaCl 0·01 gramme equivalents.	10	1·3	1·2	1·1	As translucent as paraffin wax.
	20	2·5	2·1	2·0	
	30	3·9	3·1	3·0	
	40	5·1	4·1	3·9	
	50	6·3	5·2	4·8	
NaCl 0·005 gramme equivalents.	10	1·3	1·4 (?)	(?)	Very muddy, translucency of tallow.
	20	2·5	2·4	(?)	
	30	3·8	3·4	(?)	
	40	4·8	4·3	(?)	
	50	6·1	5·3	(?)	

The following experiments, Table III., show the difference in behaviour for sea water and fresh water; the latter obtained from the city supply. Four grammes of slate were used and 10 c.cs. of liquid. The numbers are the depression of the surface of sediment in c.ms. below meniscus of liquid. It will be seen that in the fresh water suspension no surface was discoverable.

TABLE III.

Minutes elapsed.	Sea Water.	Fresh Water.
5	2·6	?
10	4·7	?
15	5·9	?
20	6·3	?
25	6·5	?
110	6·8	?

During the experiment a dark layer appeared rising in the bottom of the fresh water suspension due to the coarser particles collecting below.

In all these experiments care was taken to render the experiments strictly comparative by mounting the tubes in groups close together upon the one stand

so that all in the one group received the same amount of agitation when the sediments were being distributed and re-distributed throughout the liquid, and were approximately at the same temperature. The test tubes were selected to be as closely as possible of the same dimensions.

To what is the remarkable change appearing on re-disturbance of the sediment to be ascribed? To an abstraction of ions from the solution by the silt or to some physical change in the silt. The first explanation seems *à priori* most probable.

To investigate the matter I decanted the over-lying liquid from tubes containing sediments which had experienced frequent disturbance till all surface during settlement was lost, till sufficient was got to apply the liquid to fresh silt, not before used. All quantities and conditions being alike with those obtaining in the first experiments, it was now found that this solution was just as vigorous as it was upon the occasion of the first usage; revealing a distinct boundary surface to the descending silt and the same turbidity above. On re-disturbing those new tubes they gradually, on the second or third precipitation, lost their bounding surfaces just as in the case of the first use of the solution. This experiment being several times repeated with the same results, leaves no room to suppose that any appreciable change in the solution is responsible for the effects noticed.

The next step was to examine the sediment. The "ineffective" sediment, as for brevity I will call that which has lost the property of revealing a bounding surface during descent, left behind in the tubes which furnished the used solution for the last experiments was supplied with fresh solution, the concentration of which was the same as at first used. It was now found that the loss of surface persisted. The fresh solution left the appearance quite unchanged. In fact it is evident that to some change in the properties of the sediment the effect observed is to be ascribed.

Experiments were now made to try if increased concentrations of the ions would not restore the surface to the "ineffective" sediment. It was found that increased concentration had this effect. Thus silt which had lost surface by re-disturbance in a 0.005 gramme-equivalent solution of NaCl recovered it first in a solution of 0.010 gramme-equivalents and one which in 0.00083 gramme-equivalents of  $MgCl_2$  had lost surface regained it first visibly in a solution of 0.00111 gramme-equivalents of the same salt.

The experiments referred to may be summarised as follows:—

*On the Electrolyte.*

NaCl 0.005. 12 c.cs. which had become ineffective with 5 grams. silt were withdrawn, and 5 grams. fresh silt added. Well-defined surface: depression in 10 mins. 1.8 cms., in 30 mins. 4.8 cms.

Second settlement, some surface still produced.

Third settlement, surface almost indistinguishable.

- NaCl 0·005. As above. Depression in 10 mins. 2 cms., in 20 mins. 3 cms., in 40 mins. 5·4 cms.  
 NaCl 0·005. As above. First settlement, surface appears 2 mms. from meniscus. Second settlement at 3·5 cms. below meniscus and indistinct.

*On the Sediment.*

- Silt from NaCl 0·005. 9 c.cs. fresh NaCl 0·005. No surface even after prolonged observation.  
 Silt from NaCl 0·005. 8 c.cs. NaCl 0·010 added. Result same.  
 [As the slate occupies a true vol. of 2 c.cs. (sp. gr. 2·5), and fills 6 c.cs. of the tube, there are 4 c.cs. of interstitial solution of nearly the original concentration. The mean strength of electrolyte on second settlement is therefore 0·0083 gram. equivalents.]  
 Silt from NaCl 0·005. 8 c.cs. fresh NaCl 0·05 added. Final strength 0·035. This gives surface at once.  
 Silt from NaCl 0·005. 8 c.cs. fresh NaCl 0·025 added. Mean strength 0·0183. Good surface, upper liquid translucent as paraffin wax. Retains surface on subsequent disturbances.  
 Silt from NaCl 0·005. 8 c.cs. fresh NaCl 0·0125 added. Mean strength 0·0100. Bad surface in 5 mins., not so good as with concentration 0·005. Second settlement, no surface till 20 mins., faint, some 3 cms. depressed.  
 Silt from MgCl<sub>2</sub> 0·00083. 8 c.cs. fresh MgCl<sub>2</sub> 0·00125 added. Total concentration 0·00111. Very bad surface, about 2·5 cms. depressed.

As will be inferred from those experiments the loss of surface is reached at a lower concentration of a diad positive ion than of a monad positive ion. By seeking in successive experiments for that concentration at which the salt first lost its power of producing a "surface," on first precipitation it was found that MgCl<sub>2</sub> was 6 times as effective as NaCl, CaCl<sub>2</sub> was 5 times as effective, MgSO<sub>4</sub> was 3 times as effective, and BaCl<sub>2</sub> (acidified as usual) rather more than 5 times as effective.

TABLE IV.

LOWEST CONCENTRATIONS PRODUCING SURFACE OF SEPARATION IN FALLING SEDIMENTS.	
Gramme equivalents per litre.	
NaCl,	0·005
MgCl <sub>2</sub> ,	0·0009
CaCl <sub>2</sub> ,	0·0011
MgSO <sub>4</sub> ,	0·0016
BaCl <sub>2</sub> ,	0·001

On re-disturbance the sediment precipitated with those concentrations shows no trace of surface. At slightly lower concentrations surface may appear indistinctly at low levels on first usage. Thus MgCl<sub>2</sub> 0·00083 on first use reveals a surface 0·6 or 0·7 c.ms. below meniscus : on second settlement shows no surface whatever.

Experiments were made to determine the electric sign of the silt towards water, and salt solutions. The silt (obtained in all comparative experiments from Welsh roofing-slate), was placed in a U tube so as to close the bend. Into the liquid above platinum terminals from a storage battery dipped. The e.m.f. was 22 volts. It was found that in fresh water the liquid rose round the negative

pole, the difference of level in them being from 1 to 3 c.ms. In the case of silt in sea water no change of level was observed. According to these results the silt is negative to fresh water and neutral to sea water. When the e.m.f. was raised to 60 volts the fresh-water tube again shows the water rising round the minus pole. In the case of the sea water violent evolution of gas, and heating of the solution and the silt, render the experiment useless. The experiment of seeking if there is a greater rate of settlement in one limb of the U tube than the other, only a very attenuated sediment in fresh water being used, show that clearing seems hastened round + pole: and in this limb of the tube precipitation is densest upon the bottom. This too confirms the negative sign of the powder in fresh water. That some negative charge may linger in silt which has become "ineffective" or lost surface, was indicated by an experiment on the contents of a tube of  $MgCl_2$  (0.00125 gramme-equivalents) which had, on repeated shaking, lost all surface. This transferred to a U tube and tested by an e.m.f. of 22 volts showed a rise of liquid round the - pole of 1 m.m. in an hour. The difference in electric potential between slate-silt to distilled water is thus very considerable compared with what exists between the silt and a solution of sufficient strength to deprive it of the power of settling with a stable surface.

In seeking for an explanation of those results two facts must be kept prominently in view: the existence of a potential difference between the silt and the liquid medium around it, which only obtains upon first precipitation or is then most marked, and the difference of the electrostatic properties of the two media; the silicates (composing the silt) and the water. The specific inductive capacity of the former may be assumed to be between 4 and 7; of the latter about 80. Furthermore, the view that the ions represent centres of electric force, positive and negative—in fact, may be regarded as free charges—in continual motion, disappearance and reappearance according as re-combinations of ions or disassociations occur, will be assumed in seeking an explanation of sedimentation. The sizes of the silt particles diminish downwards to ultra-microscopic and even to molecular dimensions, probably a large proportion being of dimensions comparable with the mean distance separating the ions.\*

The interaction of these forces is most complex and difficult to analyse. The silt particles being initially negative in sign there will be attractive forces between silt and positive ions, repulsive forces between silt and negative ions, but on these forces must be superimposed those forces on the ions, arising from the presence of matter of low specific inductive capacity in a medium of high specific inductive capacity. If + and - ions find themselves separated by a silt particle, the electrostatic field between the ions can only be established through the

\* See "Subsidence of Fine Solid Particles in Liquids," Carl Barus, Bulletin of the United States Geological Survey, No. 36, 1886.

medium composing the silt at an increase of electric potential energy. The energy per unit volume of Faraday tubes being inversely as the specific inductive capacities of the two media, the ions supposed influencing one another across the matter of a silt flake will experience increased attraction. It is important to notice that this attractive effect will be greater for particles small enough to allow of close mutual approximation of the ions. In particles so large as to place the ions out of the sphere of mutual attraction the attractive effect on the negative ion will be nil. There are here forces tending to accelerate the attraction of positive ions to the particles of silt and to diminish the repulsion of negative ions. These forces do not exist for the larger particles. Thus while there is co-operation among the forces attracting + ions; there is interference between forces acting upon the negative ions: the repulsive force acting most effectively in the case of the larger particles. There is, in fact, a preponderating tendency to bring the + ions to the silt and more especially is this influence exerted in the case of larger silt particles, the attachment of negative ions being solely influenced by the establishment of lines of force in the medium of low specific inductive capacity. It may here be noted that, *alongside* of large particles, ions will not be attracted to the silt specially on account of the low specific inductive capacity of the silt: the lines of force will tend to remain in the medium of high specific inductive capacity: the effect in this case will be to increase the mutual attraction and mutual approximation of the ions, so that near the boundary between liquid and large silt particles there probably exists a layer in which re-combinations of ions occur more frequently than throughout the mass of the electrolyte. (It is probable, too, that this state of things exists at the free surface of electrolytes whether bounded by air or by glass, &c.) This greater frequency of re-combination, or greater amount of the un-ionised salt in the proximity of silt particles, does not probably influence the question of sedimentation or clumping of the particles. (It is probably a factor in the well-known ability of fine sands to extract salts from solutions. Indeed the increased electrostatic attraction arising in the low specific inductive capacity of sand or silt, and their de-ionising influence, are very certainly primary causes of this latter phenomenon.)

In order to perceive the bearing of the foregoing facts on sedimentation we must observe that these facts connote generally an expulsive action, exerted by the ions on the silt. Thus, wherever lines of force are refracted in or bent around silt particles, there is the tendency for those lines to straighten, and a lowering of electric potential energy in yielding to this tendency. If we now picture the silt particles brought by any means into close mutual approximation in the medium, this expulsive force tends to retain them in juxtaposition, the only condition being that the electric forces outside the clump of particles preponderate over those arising from ions entrapped between the particles. If the particles are so small as to approximate in dimensions to the average distance separating the ions, the

most general condition will be that particles separated by molecular distances will experience preponderating clumping forces tending to retain them in juxtaposition, and to further retain in the group any particles urged into contact with it. The particles are, in fact, everywhere expelled from the electrostatic field on the energy principles referred to; the phenomena being the inverse of those which occur when a plate of sulphur is drawn further inwards (replacing air) between the electrified plates of a condenser. Although we must look to the mechanical forces arising from lines of force which are not symmetrically distributed across silt particles tending to straighten and expel laterally the particles of low specific inductive capacity, we may state the matter more generally in the view that the silt exerts an influence opposed to the ionising forces existing in the liquid medium, and these forces consequently reacting on the silt, tend to reduce the de-ionising influence of the silt by favouring its expulsion from the medium.

In a medium exerting this expulsive force upon the suspension any mutual attractions arising in the electric sign of the particles will go towards explaining how silt particles possessing a charge might flocculate or clump more rapidly than those deprived, or almost deprived of this charge. Such attractions might arise in reversal of sign of some small particles by attraction to the negatively charged particle of positive ions; or local reversal of sign in the case of large particles; so that particles become mutually attractive. Again, the preponderating attractiveness for + ions of the larger particles in a region where silt particles were adjusting their positions under the electric forces may lead to approximation of the smaller silt particles to the larger.

But obviously in a medium possessing these expulsive properties it is only necessary to confer active motions upon the repelled particles to ensure their rapid aggregation. For in such a medium final stability is only attained by aggregation. The mutual approximation of the particles is a position of stability, their separation is not. Hence each encounter reduces the number of separate free particles. Now it is certain that in the existence of an electric charge upon the silt there arises a cause of motions among the particles which a neutral silt would not possess. Whether repulsions between negative silt and negative ions, or attractions between silt to positive ions, the results are activity. Nor need the mutual repulsion of the particles oppose final clumping, for it will everywhere happen that particles urged into collision are neutralized wholly or partially before this repulsion can effect separation.

We are in complete ignorance of the actual mechanism of the ionising forces in a liquid such as water; but that its high specific inductive capacity is probably concerned in its remarkable ionising power by weakening the electric forces between the ions has been pointed out by Professor J. J. Thomson. And it is very certain that the effect of the silt is to tend to undo this work of ionisation. On these premises the foregoing remarks are based.

Many of the experimental facts are explicable on views now advocated. We find that the finest silts are the most resistant to flocculation. The failure of the ions to produce flocculation as the concentration is diminished is first shown in the continued suspension of the finer particles. Thus the overlying liquid grows gradually more turbid, with diminished concentrations. In the case of NaCl 0.225 gram. equivs. leaves a nearly limpid liquid; at 0.112 gram. equivs. the liquid is hazy; at 0.028 it is translucent only; at 0.014 it is nearly as opaque as tallow. In the case of a diad salt the same effect is noticed.  $MgCl_2$ , traced from concentrations of 0.01 gram. equivs. downwards to 0.0008, gradually fails to clear down the finer sediment, leaving more and more in suspension, till finally surface is lost. Again, if the results of the present paper be compared with those obtained in the case of the much finer and more attenuated silts dealt with in my former experiments (*loc. cit.*), a similar law is found to obtain. The optimum in the case of the monad salt, NaCl, was near the point of saturation; in the case of  $MgCl_2$  it was at about 0.032 gram. equivalents. This may be due, in the case of fine *as well as attenuated* suspensions, in part to comparative rarity of encounters under conditions suitable to the neutralization of repulsive forces and to the effectiveness of the expulsive forces in the medium. But generally the electrostatic properties of the silt will tend to retain ions of both signs upon the finest particles; probably there is quite an atmosphere of such ions around the particles, tending to check all close aggregation. It may, therefore, well be that the electrostatic properties to which we have referred may, in cases of extreme subdivision, actually retard the effectiveness of the expulsive forces arising from these properties.

By re-shaking a precipitated sediment, we bring once more into suspension particles which are no longer at a marked negative potential. Linder and Picton have shown that ions, attaching themselves to minute colloidal particles, do so with such tenacity that even washing the precipitate with distilled water fails to remove them. We may, therefore, consider the actions which occur on second precipitation as almost uninfluenced by charges on the silt exerting attraction upon either ion. Evidently the clumping effects of the ions must now be mainly restricted to expulsive actions. When chance brings silt particles sufficiently into mutual approximation to establish a preponderating electrostatic effect urging them further together, this expulsive action of the ions will be available to forward the process of clumping. If the electrolyte is one of low concentration these actions may be feeble, without assistance from electric reactions between the silt and ions. The discharged silt exerts now no attraction upon the ions of either sign. It is probable, indeed, that the effects of increased ionic attraction across the silt medium is now most effective in securing adherence of ions of both signs upon the silt; and that herein is to be found another factor in delaying the clumping of a discharged silt.

It thus appears likely that in electrolytes above a certain concentration the expulsive action is the principal cause of flocculation, and that but little change in its rate of action is to be expected in the increased numbers of ions, owing to the rise in viscous resistance, and the effects of this on the motion of the silt particles: possibly, also, owing to increased aggregation of ions upon the silt to a degree retardative of clumping. In these cases the silt is rendered neutral towards the medium almost immediately. The "standard rate" of precipitation, as we have seen, obtains over a wide range of concentration, and considerable changes in the coefficients of ionisation.

#### SUMMARY.

The rates of settlement of suspensions consisting of 5 grammes of finely powdered solid in 12 c.c. of water containing ions in various degrees of concentration, indicate that above a certain concentration the rate of fall of the surface of the suspension is fairly independent of the degree of concentration. Below certain concentrations (about five times greater for monad positive ions than for diad) a distinct surface to the descending suspension fails, and the sediment is only seen to collect from the bottom of the vessel upwards. A suspension precipitated at a concentration so low as to be near the point of failure to show surface will, if re-shaken, not again precipitate with a distinct surface. On removing the electrolyte from such an "exhausted" suspension after it has stood sufficiently long to settle, it is found that the liquid is as effective as at first in producing surface if a fresh sample of the powder is used. On the other hand, the original powder will not again show surface when treated with fresh electrolyte of the same strength, but it will require a considerably more concentrated electrolyte to do so. The failure is therefore to be traced to some alteration in the solid particles. On testing the fresh powder it is found that this is negative towards distilled water; the used powder is apparently neutral or nearly so towards its salt solution.

An explanation of sedimentation is advanced, based on the low specific inductive capacity of the solid particles compared with the specific inductive capacity of the water, the charges on the ions being assumed to exert an expulsive action consequent on the increased energy required to establish the electric field in the medium of low specific inductive capacity. In other words, the solid particles have a de-ionising influence, and experience a reaction in consequence, which will tend to retain in juxtaposition particles which, from any cause, are once approximated. A principal cause of aggregation upon first precipitation is to be ascribed to the negative sign of the particles leading to motions all in the end favourable to aggregation, seeing that the state of aggregation is alone stable in the medium. On second disturbance the particles are neutral or nearly so, and aggregates are not formed with sufficient rapidity to lead to a general and simultaneous descent of the suspension.





## TRANSACTIONS (SERIES II.).

VOL. I.—Parts 1-25.—November, 1877, to September, 1883.

VOL. II.—Parts 1-2.—August, 1879, to April, 1882.

VOL. III.—Parts 1-14.—September, 1883, to November, 1887.

VOL. IV.—Parts 1-14.—April, 1888, to November, 1892.

VOL. V.—Parts 1-13.—May, 1893, to July, 1896.

VOL. VI.—Parts 1-16.—February, 1896, to August, 1898.

### VOLUME VII.

PART

1. A Determination of the Wave-lengths of the Principal Lines in the Spectrum of Gallium, showing their Identity with Two Lines in the Solar Spectrum. By W. N. HARTLEY, F.R.S., and HUGH RAMAGE, A.R.C.Sc.I. Plate I. (August, 1898.) 1s.
2. Radiating Phenomena in a Strong Magnetic Field. Part II.—Magnetic Perturbations of the Spectral Lines. By THOMAS PRESTON, M.A., D.Sc., F.R.S. (June, 1899.) 1s.
3. An Estimate of the Geological Age of the Earth. By J. JOLY, M.A., B.A.T., D.Sc., F.R.S., F.G.S., M.R.I.A., Honorary Secretary of the Royal Dublin Society; Professor of Geology and Mineralogy in the University of Dublin. (November, 1899.) 1s. 6d.
4. On the Electrical Conductivity and Magnetic Permeability of various Alloys of Iron. By W. F. BARRETT, F.R.S.; W. BROWN, B.Sc.; R. A. HADFIELD, M. Inst. C.E. Plates II. to IX. (January, 1900.) 4s.
5. On some Novel Thermo-Electric Phenomena. By W. F. BARRETT, F.R.S., Professor of Experimental Physics in the Royal College of Science for Ireland. Plate IXA. (January, 1900.) 1s.
6. Jamaican Actinaria. Part II.—Stichodactylinae and Zoantheae. By J. E. DUERDEN, Assoc. R. C. Sc. (Lond.), Curator of the Museum of the Institute of Jamaica. Plates X. to XV. (January, 1900.) 3s.
7. Survey of Fishing Grounds, West Coast of Ireland, 1890-1891. X.—Report on the Crustacea Schizopoda of Ireland. By ERNEST W. L. HOLT, and W. I. BEAUMONT, B.A., Cantab. Plate XVI. (April, 1900.) 1s. 6d.
8. The Action of Heat on the Absorption Spectra and Chemical Constitution of Saline Solutions. By W. N. HARTLEY, F.R.S., Royal College of Science, Dublin. Plates XVII. to XXII. (September, 1900.) 3s. 6d.
9. On the Conditions of Equilibrium of Deliquescent and Hygroscopic Salts of Copper, Cobalt, and Nickel, with respect to Atmospheric Moisture. By W. N. HARTLEY, F.R.S., Honorary Fellow of King's College, London; Professor of Chemistry, Royal College of Science, Dublin. Plates XXIII., XXIV., and XXV. (July, 1901.) 1s.
10. A New Collimating-Telescope Gun-Sight for Large and Small Ordnance. By SIR HOWARD GRUBB, F.R.S., Vice-President, Royal Dublin Society. Plate XXVI. (August, 1901.) 1s.
11. Photographs of Spark Spectra from the Large Rowland Spectrometer in the Royal University of Ireland. Part I. The Ultra-Violet Spark Spectra of Iron, Cobalt, Nickel, Ruthenium, Rhodium, Palladium, Osmium, Iridium, Platinum, Potassium Chromate, Potassium Permanganate, and Gold. By W. E. ADENEY, D.Sc., A.R.C.Sc.I., Curator and Examiner in Chemistry in the Royal University of Ireland, Dublin. Plates XXVII. and XXVIII. (September, 1901.) 1s.
12. Banded Flame-Spectra of Metals. By W. N. HARTLEY, F.R.S., Honorary Fellow of King's College, London; Royal College of Science, Dublin; and HUGH RAMAGE, B.A., A.R.C.Sc.I., St. John's College, Cambridge. Plates XXIX. to XXXIII. (October, 1901.) 1s.
13. Variation: Germinal and Environmental. By J. C. EWART, M.D., F.R.S., Regius Professor of Natural History in the University of Edinburgh. (October, 1901.) 1s.
14. The Results of an Electrical Experiment, involving the Relative Motion of the Earth and Ether, suggested by the late Professor FitzGerald. By FRED. T. TROUTON, D.Sc., F.R.S., University Lecturer in Experimental Physics, Trinity College, Dublin. (April, 1902.) 1s.
15. Some New Forms of Geodetical Instruments. By SIR HOWARD GRUBB, F.R.S., Vice-Pres. Royal Dublin Society. Plate XXXIV. (May, 1902.) 1s.
16. Some Sedimentation Experiments and Theories. By J. JOLY, D.Sc., F.R.S., F.G.S., Hon. Secretary Royal Dublin Society, Professor of Geology and Mineralogy, Trinity College, Dublin. (May, 1902.) 1s.







ACME  
BOOKBINDING CO., INC.

AUG 20 1984

100 CAMBRIDGE STREET  
CHARLESTOWN, MASS.



