

U.S. Army Coast. Eng. Res. Ctr. TR CERC
J. B. Carver

TECHNICAL REPORT CERC-85-12



US Army Corps
of Engineers

SEAWALL AND REVETMENT STABILITY STUDY, CAPE HATTERAS LIGHTHOUSE, NORTH CAROLINA

by

Peter J. Grace, Robert D. Carver

Coastal Engineering Research Center

DEPARTMENT OF THE ARMY
Waterways Experiment Station, Corps of Engineers
PO Box 631, Vicksburg, Mississippi 39180-0631

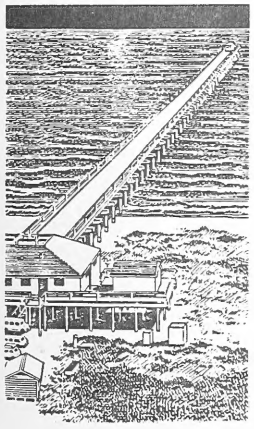

December 1985
Final Report

Approved For Public Release; Distribution Unlimited

Prepared for

US Army Engineer District, Wilmington
Wilmington, North Carolina 28402
and The National Park Service
Southeast Regional Office
US Department of the Interior
Atlanta, Georgia 30349

ENG
G-3
450
T45
no. CERC-
85-12

Destroy this report when no longer needed. Do not return
it to the originator.

The findings in this report are not to be construed as an official
Department of the Army position unless so designated
by other authorized documents.

The contents of this report are not to be used for
advertising, publication, or promotional purposes.
Citation of trade names does not constitute an
official endorsement or approval of the use of
such commercial products.

Unclassified

SECURITY CLASSIFICATION OF THIS PAGE (When Data Entered)

REPORT DOCUMENTATION PAGE		READ INSTRUCTIONS BEFORE COMPLETING FORM
1. REPORT NUMBER Technical Report CERC-85-12	2. GOVT ACCESSION NO.	3. RECIPIENT'S CATALOG NUMBER
4. TITLE (and Subtitle) SEAWALL AND REVETMENT STABILITY STUDY, CAPE HATTERAS LIGHTHOUSE, NORTH CAROLINA		5. TYPE OF REPORT & PERIOD COVERED Final report
		6. PERFORMING ORG. REPORT NUMBER
7. AUTHOR(s) Peter J. Grace Robert D. Carver		8. CONTRACT OR GRANT NUMBER(s)
9. PERFORMING ORGANIZATION NAME AND ADDRESS US Army Engineer Waterways Experiment Station Coastal Engineering Research Center PO Box 631, Vicksburg, Mississippi 39180-0631		10. PROGRAM ELEMENT, PROJECT, TASK AREA & WORK UNIT NUMBERS
11. CONTROLLING OFFICE NAME AND ADDRESS US Army Engineer District, Wilmington PO Box 1890, Wilmington, North Carolina 28402 The National Park Service, Southeast Regional Office, US Department of the Interior Atlanta, Georgia 30349		12. REPORT DATE December 1985
		13. NUMBER OF PAGES 248
		15. SECURITY CLASS. (of this report) Unclassified
14. MONITORING AGENCY NAME & ADDRESS (if different from Controlling Office)		15a. DECLASSIFICATION/DOWNGRADING SCHEDULE
16. DISTRIBUTION STATEMENT (of this Report) Approved for public release; distribution unlimited.		
17. DISTRIBUTION STATEMENT (of the abstract entered in Block 20, if different from Report)		
18. SUPPLEMENTARY NOTES Available from National Technical Information Service, 5285 Port Royal Road, Springfield, Virginia 22161		
19. KEY WORDS (Continue on reverse side if necessary and identify by block number)		
Armor stone	Seawalls	
Cape Hatteras	Stapods	
Hydraulic models	Water Waves	
Revetments	Wave pressures	
20. ABSTRACT (Continue on reverse side if necessary and identify by block number)		
<p>A two-dimensional model investigation was conducted to provide input for the design optimization of a seawall-revetment shore protection system proposed for long-term protection of the lighthouse at Cape Hatteras, North Carolina. The specific purposes of this investigation were as follows:</p> <p>a. Tests were performed to determine the most severe wave conditions relative to the stability of the seawall and stone</p> <p style="text-align: right;">(Continued)</p>		

MBL/WHOI
 0 0301 0091249 9
 5 6429TL00
 0 0301 0000

20. ABSTRACT (Continued).

revetment within the limits of still-water levels and wave periods that could be expected to occur in the prototype area. These tests led to the development of a storm-surge hydrograph to which the seawall-revetment sections were subjected. The hydrograph included still-water levels of +2.6, +4.3, +6.9, and +8.6 ft mean sea level and wave periods of 6, 8, 10, 12, and 14 sec. The most severe breaking wave heights ranged from 9.0 to 17.0 ft.

- b. Several stone revetment sections were tested under the worst breaking wave conditions to optimize the geometry and stone sizes. Results indicated that the revetment plan characterized by 6.3-ton primary armor stone would be an adequate design.
- c. Pressure tests were conducted to determine the distribution of wave forces on the seawall so that the seawall could be designed to withstand the resultant forces and ensure stability against overturning and sliding. The seawall geometries tested included a vertical wall and two recurved walls. The two recurved seawalls were very similar in design; however, one included a slightly different crown geometry designed to reduce overtopping. Results indicated that the modified recurved seawall (Plan R4S3) was the most suitable design tested in terms of minimizing pressures on the face of the wall and reducing runup and overtopping.

PREFACE

The model investigation reported herein was requested by the US Army Engineer District, Wilmington, (SAW), in a letter to the US Army Engineer Waterways Experiment Station (WES), dated 29 June 1983. Funding authorization was initially granted by SAW on Intra-Army order No. SAWEN-C-83-135, dated 28 June 1983.

Model tests were conducted at WES during the period August 1983 to July 1984, under the general direction of Dr. R. W. Whalin, Chief, Coastal Engineering Research Center (CERC), WES; Mr. C. E. Chatham, Jr., Chief, Wave Dynamics Division, CERC; and Mr. D. D. Davidson, Chief, Wave Research Branch, CERC. Tests were conducted by Messrs. P. J. Grace and R. D. Carver, Research Hydraulic Engineers, and C. R. Herrington, Technician. This report was prepared by Messrs. Carver and Grace.

Director of WES at the time of publication of this report was COL Allen F. Grum, USA. Technical Director was Dr. Robert W. Whalin.

CONTENTS

	<u>Page</u>
PREFACE.....	1
CONVERSION FACTORS, NON-SI TO SI (METRIC) UNITS OF MEASUREMENT.....	3
PART I: INTRODUCTION.....	4
The Prototype.....	4
The Problem.....	5
Purpose of the Model Study.....	5
PART II: THE MODEL.....	6
Design of the Model.....	6
Test Facilities and Equipment.....	7
Test Procedures.....	7
Test Setup.....	12
PART III: REVETMENT STABILITY TESTS.....	15
Selection of Test Conditions.....	15
Plans Tested and Results.....	16
PART IV: WAVE PRESSURE TESTS.....	21
Plan R4S1 Test Results.....	21
Plan R4S2 Test Results.....	23
Plan R4S3 Test Results.....	26
PART V: CONCLUSIONS AND DISCUSSION.....	29
Conclusions.....	29
Discussion.....	29
REFERENCES.....	31
TABLES 1-11	
PHOTOS 1-30	
PLATES 1-100	

CONVERSION FACTORS, NON-SI TO SI (METRIC)
UNITS OF MEASUREMENT

Non-SI units of measurement used in this report can be converted to SI (metric) units as follows:

<u>Multiply</u>	<u>By</u>	<u>To Obtain</u>
feet	0.3048	metres
inches	2.54	centimetres
miles (US statute)	1.609347	kilometres
pounds (force) per square inch	6.894757	kilopascals
pounds (mass)	0.4535924	kilograms
pounds (mass) per cubic foot	16.01846	kilograms per cubic metre
tons (2,000 pounds, mass)	907.1847	kilograms

SEAWALL AND REVETMENT STABILITY STUDY,
CAPE HATTERAS LIGHTHOUSE, NORTH CAROLINA

PART I: INTRODUCTION

The Prototype

1. Cape Hatteras, the easternmost point of North Carolina, projects from a narrow curved sand strip. This sand strip, known as the outer banks, parallels the North Carolina coast for about 180 miles* (Figure 1). The Cape

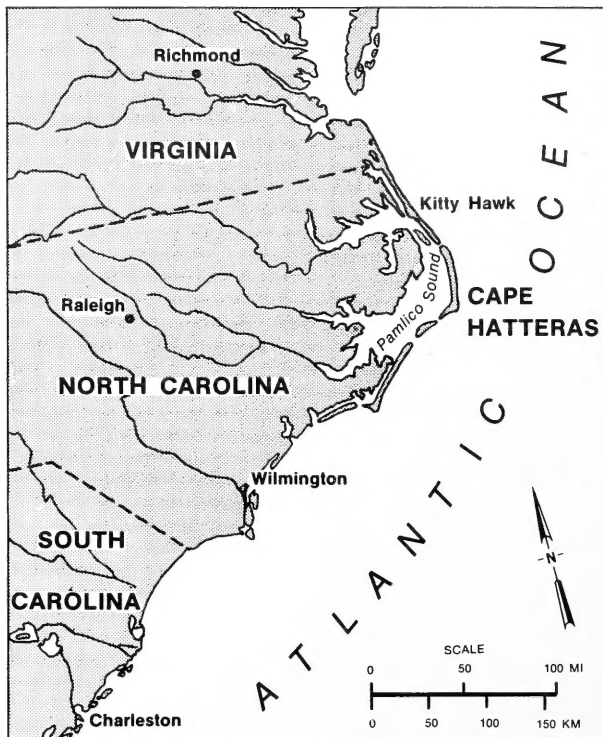

Figure 1. Project location map

* A table of factors for converting non-SI units of measurement to SI (metric) units is presented on page 3.

Hatteras National Seashore, which includes the lighthouse, was established in 1953 and is managed by the National Park Service (NPS). The Cape Hatteras Lighthouse is located near Buxton, N. C.

The Problem

2. It is anticipated that erosion and gradual shoreline retreat will eventually diminish the beach fronting the Cape Hatteras Lighthouse. The US Army Engineer District, Wilmington, (SAW), is providing design expertise to NPS for the development of coastal protection works to safeguard the lighthouse. The plan of protection selected by NPS consists of encircling the lighthouse with a wave-reflecting seawall fronted by a stone revetment.

Purpose of the Model Study

3. The model study was conducted to determine the adequacy of the proposed seawall and revetment design and, if necessary, to develop alternate designs from which an optimum plan for stability and economy could be determined. The specific purposes of this investigation were to determine:

- a. The most severe wave conditions relative to stability of the seawall and stone revetment within the limits of still-water levels (swl's)* and wave periods that could be expected to occur in the area of the Cape Hatteras Lighthouse.
- b. The stability and optimum stone size of the rubble stone revetment under worst breaking wave conditions.
- c. The distribution of wave forces on the gravity seawall so that it could be designed to withstand their resultant forces and ensure stability against overturning and sliding.
- d. A seawall curvature that would prevent overtopping and minimize the resultant wave forces on the seawall itself.
- e. The combined stability of the seawall and revetment resulting from the hydraulic interaction of the two components.

* All still-water levels cited herein are in feet mean sea level (msl).

PART II: THE MODEL

Design of the Model

4. Tests were conducted at an undistorted linear scale of 1:25, model to prototype. Scale selection was based on the size of model armor units available compared to the estimated size of prototype armor units required for stability, capabilities of the available wave generator, and elimination of stability scale effects (Hudson 1975). Based on Froude's Model Law (Stevens et al. 1942) and the linear scale of 1:25, the following model-to-prototype relations were derived. Dimensions are in terms of length (L) and time (T).

<u>Characteristic</u>	<u>Dimension</u>	<u>Model-to-Prototype Scale Relation (r)</u>
Length	L	$L_r = 1:25$
Area	L^2	$A_r = L_r^2 = 1:625$
Volume	L^3	$V_r = L_r^3 = 1:15,625$
Time	T	$T_r = L_r^{1/2} = 1:5$

5. The specific weight of water used in the model was assumed to be 62.4 pcf and that of seawater is 64.0 pcf. Specific weights of the model construction materials were not identical to their prototype counterparts. These variables were related using the following transference equation:

$$\frac{\left(\frac{W_a}{W_w}\right)_m}{\left(\frac{W_a}{W_w}\right)_p} = \frac{\left(\gamma_a\right)_m}{\left(\gamma_a\right)_p} \left(\frac{L_m}{L_p}\right)^3 \left[\frac{\left(\frac{S_a}{S_w}\right)_p - 1}{\left(\frac{S_a}{S_w}\right)_m - 1} \right]^3 \quad (1)$$

where

m and p = model and prototype quantities, respectively

W_a = weight of an individual armor unit, lb

γ_a = specific weight of an individual armor unit, pcf

L_m/L_p = linear scale of the model

S_a = specific gravity of an individual armor unit relative to the water in which it was placed, i.e., $S_a = \gamma_a/\gamma_w$,

where γ_w is the specific weight of water, pcf.

6. The model seawall was constructed to reproduce the geometric shape of the prototype structure. Allowances were made for modifications in the geometric shape of the seawall face to accommodate proposed alternatives, i.e., vertical and recurved seawalls. The midsection of the seawall was equipped with features allowing installation of transducers for measuring wave pressures. Aluminum was chosen for construction of this 1-ft-wide section due to its availability, workability, and thermal conductivity.

Test Facilities and Equipment

7. A concrete wave flume 5 ft wide, 4 ft deep, and 119 ft long was used for all tests. The flume is equipped with a vertical displacement wave generator capable of producing monochromatic waves of various periods and heights. Test waves of the required characteristics were generated by varying the frequency and amplitude of the plunger motion. Test sections were installed in the flume approximately 89 ft from the wave generator. As shown in Figure 2, postulated local prototype bathymetry seaward of the test sections was represented by a compound slope of 1V:22H and 1V:60H for simulated prototype distances of 110 and 1,200 ft (4.4 and 48.0 ft in the model), respectively.

8. Wave pressures were measured using miniature semiconductor pressure transducers, each equipped with a silicon diaphragm and a 4-arm strain gage bridge. Pressure measurements were calibrated and recorded using a micro-computer. Data were stored on 8-in. floppy discs. Wave pressures were also recorded by an oscillograph capable of accurately recording the high-frequency pressure variations. Simultaneous pressure measurements were made at up to 12 different locations along the face of the seawall. Figures 3-5 show these locations for each seawall alternative.

Test Procedures

Calibration of the test facility

9. At the US Army Engineer Waterways Experiment Station (WES), calibration of the wave facility is normally performed without the test section in place; therefore, conditions are analogous to the prototype conditions for which the measured and/or hindcasted wave data were determined. Electrical-resistance type wave gages were positioned in the flume at a point that would

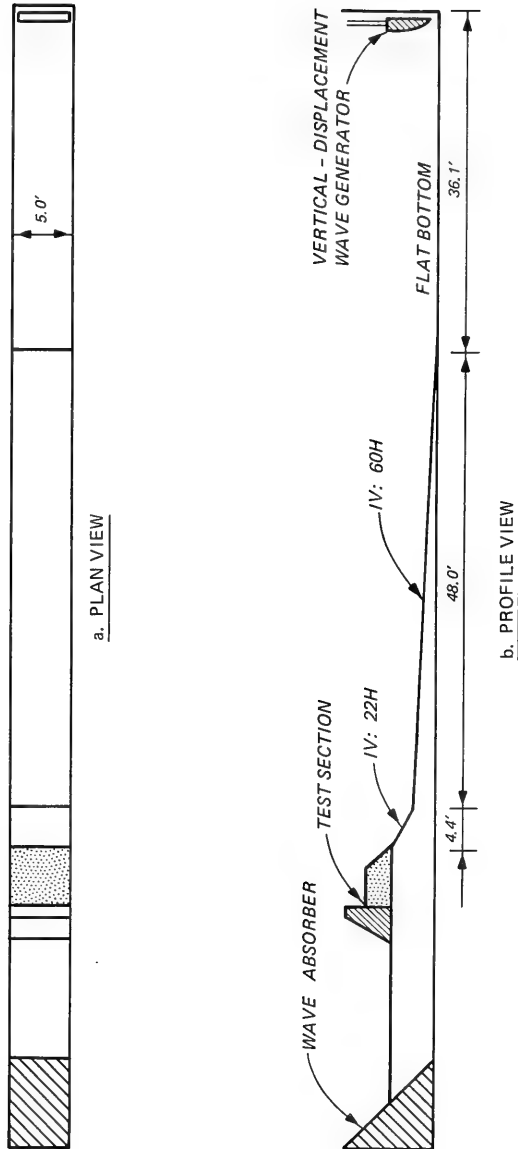

Figure 2. Wave flume cross section

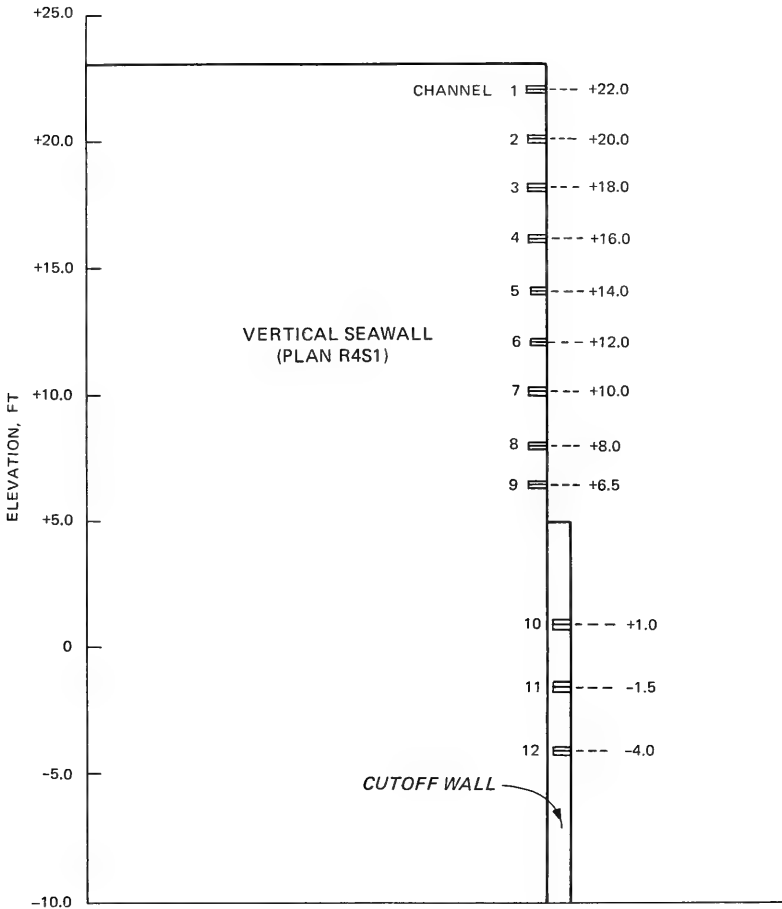

Figure 3. Pressure transducer locations on vertical seawall

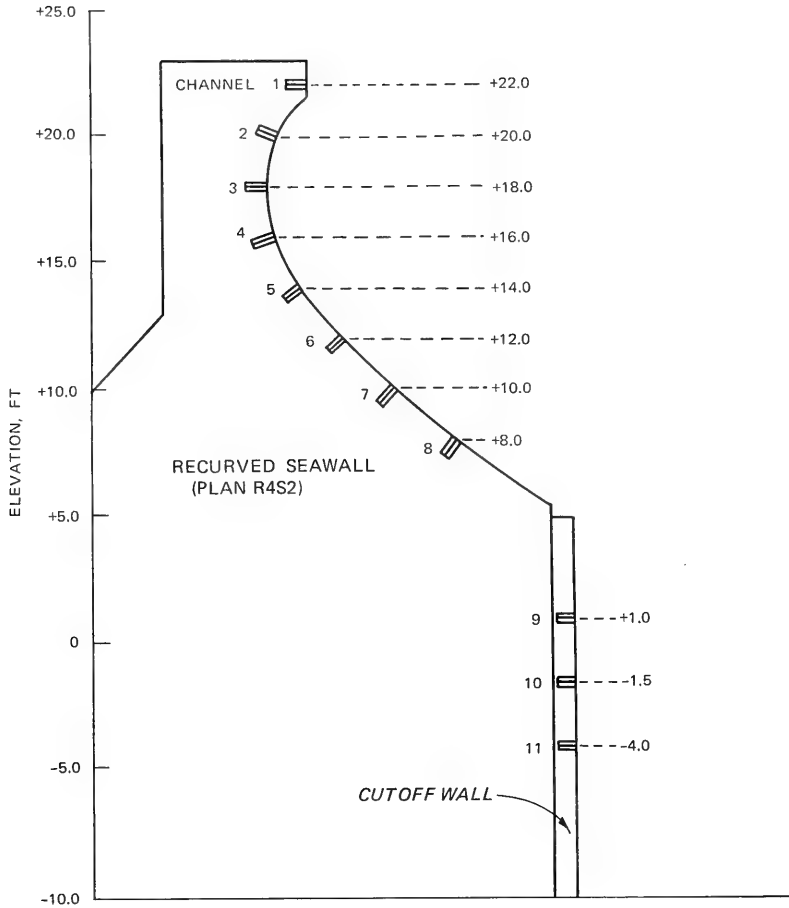

Figure 4. Pressure transducer locations on recurved seawall

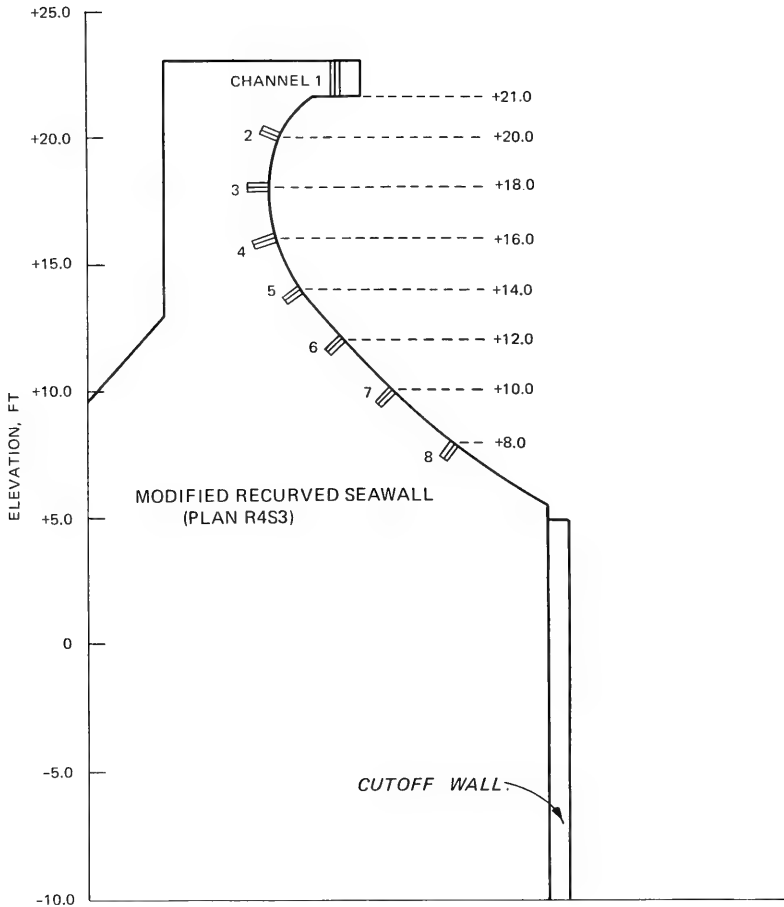

Figure 5. Pressure transducer locations on modified recurved seawall

coincide with the toe of the proposed revetment section, and the wave generator was calibrated for various wave conditions. Once calibration was completed, the vertical seawall and first revetment section were placed in the wave flume and the wave generator was "tuned" to determine the most severe breaking waves that could be experimentally made to attack the structure; i.e., for each swl and wave period, the wave generator stroke was varied slightly until the most severe wave condition relative to armor stability was obtained. These wave conditions were then incorporated into the hurricane storm-surge hydrograph and the abbreviated storm-surge hydrograph. Plates 1 and 2 show the hydrographs which were used in the revetment stability tests.

Method of constructing revetment sections

10. Model revetment sections were constructed to reproduce, as closely as possible, the results of prototype revetment construction. Bedding material, dumped by bucket or shovel, was compacted and smoothed to grade with hand trowels in an effort to simulate the natural consolidation that would occur during prototype construction. With the bedding material in place, the underlayer was added by shovel and smoothed to grade by hand or with trowels. Exposure of the underlayer to excessive pressure or compaction was carefully avoided. The row of stapods (each stapod weighed 10,000 lb on all test sections) was positioned by hand on the bedding material or underlayer, depending on the revetment alternative. Armor stone cover layers were constructed using random placement; i.e., stones were individually hand-placed, but no intentional interlocking or special orientation was achieved.

Test Setup

Revetment stability tests

11. A typical revetment stability test consisted of subjecting the revetment and seawall test section to attack by waves of a given height and period for a specified time duration. The wave conditions, water levels, and time increments were determined by the hydrograph selected for testing. Testing time was accumulated in 30-sec (model time) cycles; i.e., the wave generator was started, run for 30 sec, and then stopped. Use of this procedure ensured that the structures were not subjected to an undefined system of waves created by reflections from the model boundaries and wave generator. After

each 30-sec cycle, sufficient time was provided for stilling of the water surface before the next cycle was begun. During this stilling time, observations of the structure's response to the previous cycle were recorded by the model operator. These observations included any movement occurring on the structure and a general statement of the condition of the structure at that point in the test. Structural responses to the hydrographs were also documented by before- and after-testing photographs (Photos 1-30).

Wave pressure tests

12. After an adequate revetment design was determined, the revetment test section was rebuilt. The seawall was then instrumented in preparation for the wave pressure measurements.

13. The first series of pressure tests for each seawall consisted of recording pressures at several locations along the face of the wall for various wave conditions and water levels. Because simultaneous measurements were made at several locations on the wall, the capabilities of the microcomputer system limited the sampling rate to approximately 200 samples per second. It was realized that this sampling rate could be insufficient to record the very highest peak pressures that occur in the millisecond range; however, SAW structural engineers indicated that the sampling range was sufficient for their needs because they did not feel the prototype structure would have time to respond to the high-frequency forces.

14. Pressure data were also taken on oscillograph records as a backup system to the microsystem. Results from the two different recording systems were cross-checked to assure the best possible measurements.

15. In a typical test, the wave generator was first started. Three waves were then allowed to strike the structure. Between the third and fourth crests, pressure measurements were initiated. The microcomputer system stopped sampling 15 sec later and the wave generator was stopped 30 sec after it was started. The oscillograph recorded time-pressure distributions for all waves except the first three. After each 30-sec test, sufficient time was provided for stilling of the flume before the next test was begun. During this stilling time, water from the test flume was pumped over the face of the seawall to prevent thermal drift of the instrumentation located above the swl.

16. Results of this first series of tests were used to select the best overall seawall alternative. Following this selection, the four most critical waves that produced the greatest pressures on the selected seawall were chosen

and repeat tests were run in an effort to obtain sufficient data to perform a statistical analysis. Therefore, 100 waves of each condition were run and the corresponding pressures were recorded. These tests were performed in the same manner as described earlier; however, since the number of transducers used was reduced from 12 to 8, the sampling rate was increased to approximately 280 samples/sec.

PART III: REVETMENT STABILITY TESTS

Selection of Test Conditions

17. Revetment sections were initially subjected to exploratory stability tests using the abbreviated (4-hr) storm-surge hydrograph (Plate 1). This hydrograph incorporated the most severe breaking waves with periods of 6, 8, 10, and 12 sec for each swl of +2.6, +4.3, +6.9, and +8.6 ft msl. Each combination of water level and wave period was tested for 15 min; thus, a total storm duration of 4 hr was represented. It was later decided that wave periods of 14 sec and possibly even 16 sec could occur along this reach of shoreline. With this in mind, testing was begun with the intention that once a stable design was achieved for the abbreviated hydrograph, the effects of longer wave periods would be assessed and included in a 13-hr storm-surge hydrograph. Subsequently, it was decided that because of the infrequent occurrence of 16-sec waves, full revetment stability against their attack was not warranted; therefore, only 14-sec waves were included in the 13-hr hydrograph (Plate 2). The most severe breaking waves which could experimentally be made to attack the sections for the selected wave period range (6 to 14 sec) were as follows:

<u>swl</u> <u>ft, msl</u>	<u>Wave</u> <u>Period</u> <u>sec</u>	<u>Most Severe</u> <u>Breaking Wave</u> <u>Height, ft</u>	<u>swl</u> <u>ft, msl</u>	<u>Wave</u> <u>Period</u> <u>sec</u>	<u>Most Severe</u> <u>Breaking Wave</u> <u>Height, ft</u>
+2.6	6	9.0	+6.9	6	10.7
+2.6	8	11.1	+6.9	8	13.4
+2.6	10	11.0	+6.9	10	15.7
+2.6	12	12.6	+6.9	12	16.0
+2.6	14	12.7	+6.9	14	16.3
+4.3	6	11.5	+8.6	6	12.5
+4.3	8	13.1	+8.6	8	14.1
+4.3	10	12.8	+8.6	10	15.8
+4.3	12	12.7	+8.6	12	16.8
+4.3	14	13.1	+8.6	14	17.0

Plans Tested and Results

18. Revetment stability tests were begun with the vertical seawall in place and a total of four plans were subjected to the abbreviated storm-surge hydrograph before a stable design was obtained. Throughout this series of tests, it was found that of the 6-, 8-, 10-, and 12-sec waves, those with a period of 12 sec were the most severe in terms of revetment stability.

19. Common characteristics of all plans were the use of a toe elevation of -10 ft msl, 5-ton stapods, and filter and underlayer stone weights of 2 to 60 lb, and 150 lb, respectively. Also, armor materials seaward of the stapods were considered sacrificial and their movement was not considered in evaluating the stability response of the various plans. Observations of this material during testing showed that this material was usually dragged downslope and did not physically impact the stapods. Details of the plans tested and general results are discussed in the following paragraphs.

Plan R1S1

20. Plan R1S1 (Plate 3, and Photos 1 and 2) was constructed to a crown elevation of +4.5 ft msl, with the stapods resting on the 2- to 60-lb filter stone (W_5). Weights of the primary armor stone (W_2) and toe-protection armor stone (W_3) were 2.5 tons and 1.0 ton, respectively.

21. Exposure of Plan R1S1 to the abbreviated storm-surge hydrograph resulted in extensive damage with a large amount of armor stone displacement distributed over the structure; however, the stapods proved to be stable. Photos 3 and 4 show the condition of the structure after testing.

Plan R2S1

22. Plan R2S1 (Plate 4, and Photos 5 and 6) was similar to Plan R1S1; however, the weights of the primary armor stone (W_2) and toe-protection armor stone (W_3) were increased to 3.8 tons and 2.5 tons, respectively. In order to maintain the -0.8 ft elevation at the top of the 1V:1.25H toe slope, it was necessary to decrease the thickness of the filter stone (W_5) from 2.5 to 0.9 ft. The slope of the primary armor stone was increased to 1V:1.8H. The crown elevation of +4.5 ft was maintained.

23. The stability response of Plan R2S1 to the abbreviated storm-surge hydrograph was significantly better than that of Plan R1S1. However, this revetment design was still unacceptable due to excessive displacement of the 3.8-ton armor stone. The after-testing condition of this plan is shown in Photos 7 and 8.

Plan R3S1

24. Plan R3S1 (Plate 5, and Photos 9 and 10) was similar to the preceding plans except the weight of the primary armor stone (W_2) was increased to 4.9 tons. The greater stone size resulted in an increase of the crown elevation to 4.8 ft msl.

25. When subjected to the abbreviated storm-surge hydrograph, Plan R3S1 demonstrated improved stability as compared to the previous plans. However, as shown in Photos 11 and 12, the design was unacceptable due to excessive movement of the primary armor stone.

Plan R4S1

26. Plan R4S1 (Plate 6, and Photos 13 and 14) was constructed using 6.3-ton primary armor stone (W_2) placed on a 1V:3.5H slope. The crown elevation was increased to 5.0 ft msl and the elevation of the stapods was increased by placing them on the underlayer stone (W_{11}).

27. When subjected to the abbreviated storm-surge hydrograph, damage to Plan R4S1 was minor and the stability response was considered acceptable. Some armor stones shifted positions as they sought a more stable orientation and one 6.3-ton stone was carried seaward of the stapods. As waves struck the vertical seawall, energy directed downward had a tendency to force stone lying adjacent to the wall slightly seaward. Eventually some settlement occurred; however, the overall integrity of the section was not affected, and it was decided to subject this design to the full-scale storm-surge hydrograph. Photos 15 and 16 show the condition of the structure after testing with the abbreviated hydrograph.

28. Exposure to the 13-hr storm-surge hydrograph was initiated. Results obtained were very similar to those observed with the abbreviated hydrograph. There was some minor damage due to stone displacement during the earlier hydrograph steps and again one of the primary armor stones was carried seaward to the toe area. The most severe problem resulted in a significant damage in the area adjacent to the seawall. Because of severe wave impact at the wall, forces directed down the face of the cutoff wall were able to gradually cause scour, settlement, and a seaward displacement of material at the seawall-revetment interface. This damage did not involve the displacement of individual armor stones; instead, the entire revetment section was moved slightly seaward as a unit. Photos 17 and 18 show the settlement at the wall, the wedge-shaped gap between the cutoff wall and the revetment, and the

seaward displacement of the entire section. This displacement is most apparent in Photo 18, when the altered positions of the stapods and the most seaward primary armor stones are observed. This problem is an inevitable consequence of fronting the vertical seawall with a stone revetment and subjecting the structure to wave conditions of the severity described herein. After consultation with SAW, it was felt that this problem could not be resolved by changing the geometry of the revetment or by further increasing the armor stone weights. Therefore, revetment stability tests of Plan R4S1 were discontinued. Plan R4S2

29. The revetment portion of Plan R4S2 (Plate 7, and Photos 19 and 20) was identical to Plan R4S1. This plan differed from those previously tested in that the vertical seawall was replaced with a recurved seawall. Details of this wall design are shown in Figure 6.

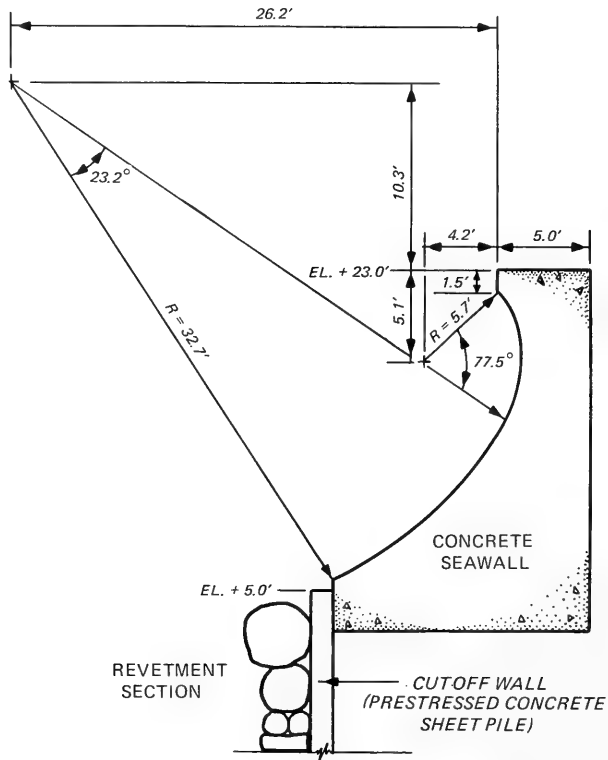

Figure 6. Details of seawall curvature, Plan R4S2

30. Subjection of Plan R4S2 to the abbreviated storm-surge hydrograph resulted in minor damage. Two primary armor stones were displaced and several others shifted slightly in place. The stability response of this plan was considered acceptable. Photos 21 and 22 show the after-testing condition.

31. Following completion of the abbreviated hydrograph tests, the structure was subjected to the 13-hr hurricane storm-surge hydrograph. Again, an acceptable stability response was exhibited. Although several armor stones shifted positions slightly, none were displaced, and the functional and structural integrity of the revetment was maintained. Photos 23 and 24 show the structure after completion of step 4, and Photos 25 and 26 show the condition at the conclusion of testing. Comparison of these photographs with Photos 21 and 22 indicates that very little change occurred during exposure to the 13-hr storm-surge hydrograph.

Plan R4S3

32. After the determination that Plan R4S2 was an acceptable design in terms of revetment stability, there was some concern about the amount of overtopping observed with certain wave conditions. Discussions with SAW resulted in a proposed modification to the recurved seawall. For aesthetic reasons, it was felt that the crown elevation of the seawall should not be increased; therefore, the overhang at the top of the seawall was extended seaward by 2 ft as shown in Figure 7.

33. Plan R4S3 (Photos 27 and 28) was tested to determine whether the structural alteration would affect revetment stability and to compare the overtopping by visual observation. The revetment of this plan was the design which had proven adequate in Plan R4S2.

34. Exposure of Plan R4S3 to the abbreviated hydrograph resulted in no damage. There was some minor in-place rocking and shifting of several armor stones, but no stones were displaced. Further subjection of the structure to the 13-hr storm-surge hydrograph yielded similar results, and it was evident that Plan R4S3 was acceptable in terms of revetment stability. The after-testing condition is shown in Photos 29 and 30.

35. During the previous testing of Plan R4S2, significant overtopping was noticeable at the +8.6 ft swl with 12-sec and particularly 14-sec waves. Although no quantitative measurements of the amount of overtopping were performed, visual observations indicated that Plan R4S3 significantly reduced the overtopping.

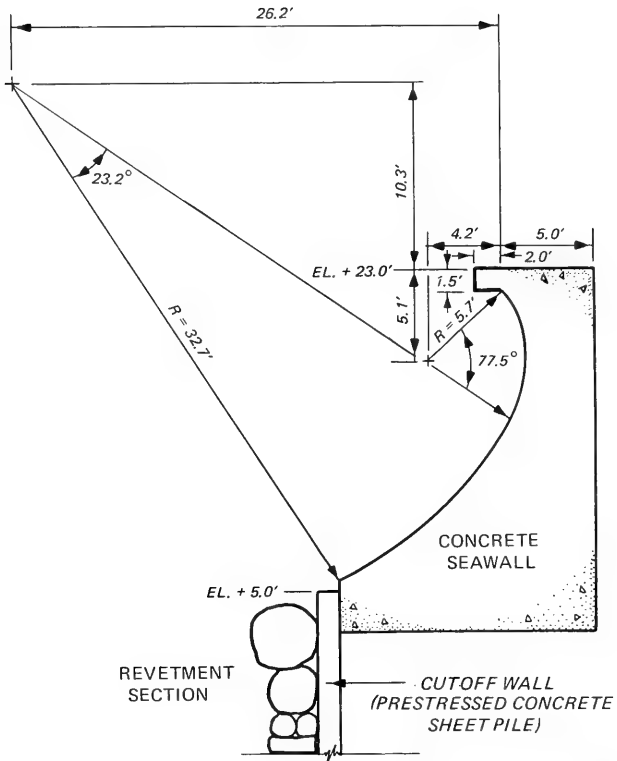

Figure 7. Details of seawall curvature, Plan R4S3

PART IV: WAVE PRESSURE TESTS

36. Following the determination of an adequate revetment design, wave pressure tests were performed. The purpose of these tests was to provide pressure data necessary to determine the distribution of wave forces for a variety of wave conditions. Based on these data, the most suitable seawall alternative could be chosen and designed to withstand the corresponding resultant forces and ensure stability against overturning and sliding.

37. Tests were conducted at swl's of +2.6, +4.3, +6.9, and +8.6 ft msl for wave periods ranging from 6 to 14 sec. The most severe breaking waves which experimentally could be made to attack the test sections were investigated. In addition, selected nonbreaking and prebreaking waves were tested at swl's of +6.9 and +8.6 ft to provide a wide range of wave conditions on which the seawall selection and design could be based. Wave conditions selected for the wave pressure tests are given in Table 1.

38. Typical wave pressure oscillograph records for the seawalls and cutoff wall are presented in Figure 8. Wave pressure-time histories indicated that as a wave struck the seawall, it caused a shock pressure (or impact pressure) of large magnitude and short duration, followed by a secondary pressure (or surge pressure) of lesser magnitude and longer duration. Based on experiments conducted with a vertical wall, Bagnold (1939) theorized that these short-duration shock pressures resulted from the rapid compression of an air pocket trapped between the face of a breaking wave and the wall. This shock pressure phenomenon and its occurrence relative to vertical walls has been studied by several investigators (Minikin 1946; Carr 1954; Kamel 1968a, 1968b; Garcia 1968). As shown in Figure 8, wave pressure records for the sheet pile cutoff wall are of similar form except for the negative secondary pressures which occurred during wave drawdown.

Plan R4S1 Test Results

39. The first series of pressure tests was conducted with the vertical seawall in place. This plan was equipped with 12 transducers located at elevations of +22.0, +20.0, +18.0, +16.0, +14.0, +12.0, +10.0, +8.0, +6.5, +1.0, -1.5, and -4.0 ft msl. A profile sketch of this seawall showing transducer locations is shown in Figure 3.

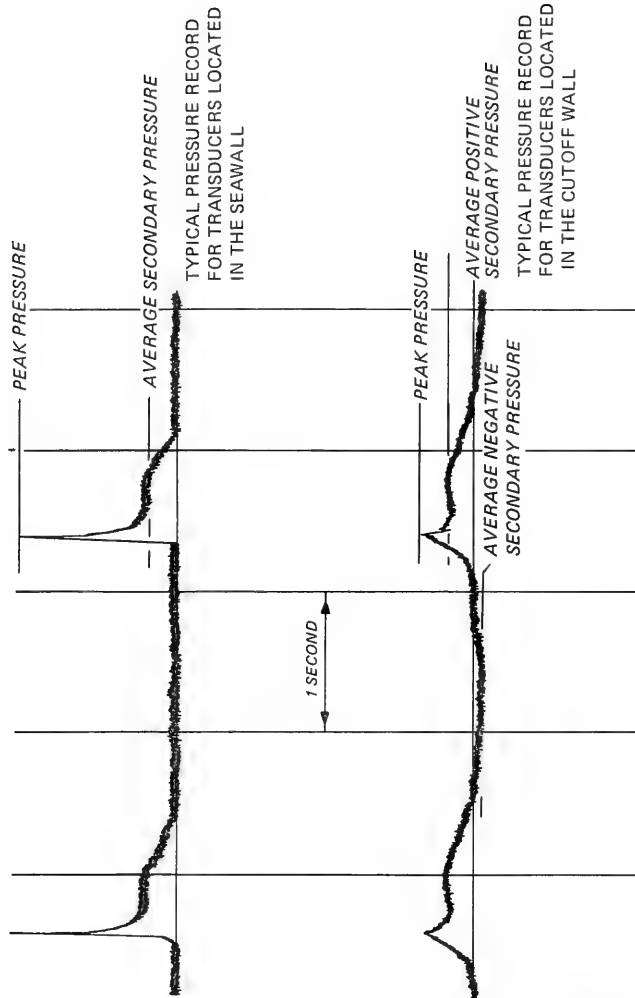

Figure 8. Typical pressure-time record for waves breaking on the structure

40. The structure was subjected to the 36 different water level-wave condition combinations shown in Table 1 and the corresponding wave pressures were recorded. A test duration of 30 sec was used, as discussed previously, and the number of representative waves for which pressures were observed ranged from 7 to 12 depending on the wave period. Results of the shock pressure tests are given in Table 2. Figure 9 shows one of the more severe breaking waves impinging on the vertical seawall at an swl of 8.6 ft msl.

41. One of the most noticeable characteristics of these data is the variability in shock pressures for identical incident waves. The range between the minimum and maximum shock pressures, especially for the more severe water level-wave conditions, was large. In order to provide a graphical presentation of the wave pressure profile for each of the 36 conditions, a representative wave was chosen from the 7 to 12 available waves and plotted as shown in Plates 8-25. These figures indicate, with few exceptions, that maximum shock pressures occurred near the still-water level. The greatest pressures occurred at +6.9 and +8.6 ft swl with wave periods of 12 and 14 sec.

42. As expected, secondary pressures were much lower than the corresponding shock pressures and there was less variability in the secondary pressures for identical waves. Because of this consistency, the 7 to 12 secondary pressures measured at each location, for each set of conditions, were averaged and these data are presented in Table 3. The durations of the secondary pressures were also relatively consistent at approximately 2.5 sec (prototype).

Plan R4S2 Test Results

43. Pressure transducers were mounted in the recurved seawall at elevations of +22.0, +20.0, +18.0, +16.0, +14.0, +12.0, +10.0, +8.0, +1.0, -1.5, and -4.0 ft msl. A profile sketch of this seawall and its 11 transducers locations is shown in Figure 4.

44. This structure was subjected to the same wave conditions used for testing the vertical seawall, and test results are included in Table 4. Figure 10 shows a 14-sec, 11.4-ft wave impinging on the structure at an swl of +8.6 ft.

45. When compared with the corresponding shock pressures measured on the vertical wall, the magnitudes of shock pressures were substantially less with the recurved wall. Also, shock pressures recorded for consecutive waves



b.



d.



a.



c.

Figure 9. Attack of a 14-sec, 11.4-ft breaking wave on the vertical seawall (Plan R4S1) at an swl of +8.6 ft

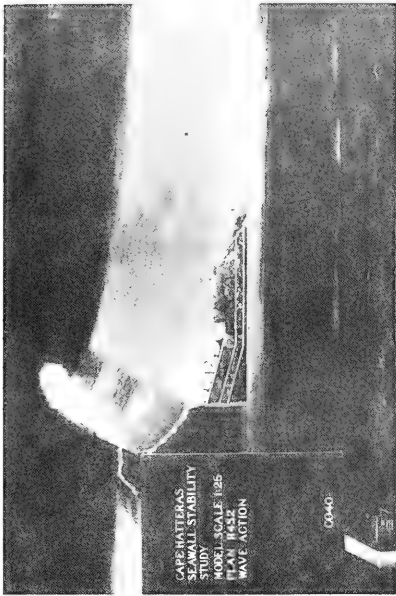

a.

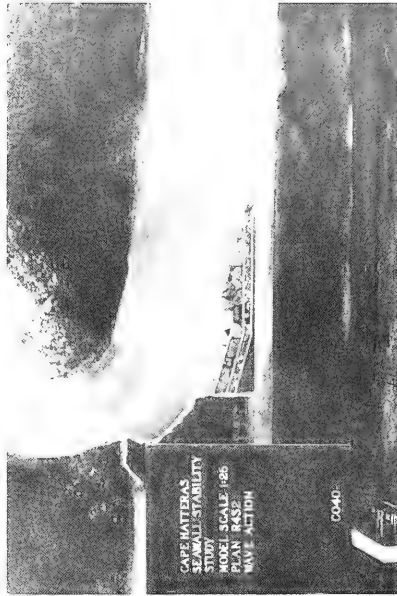

b.

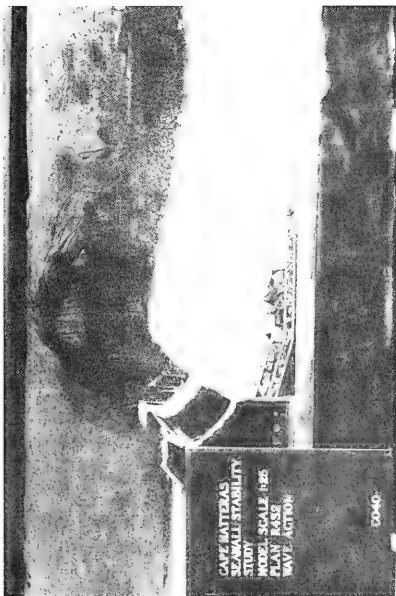

c.

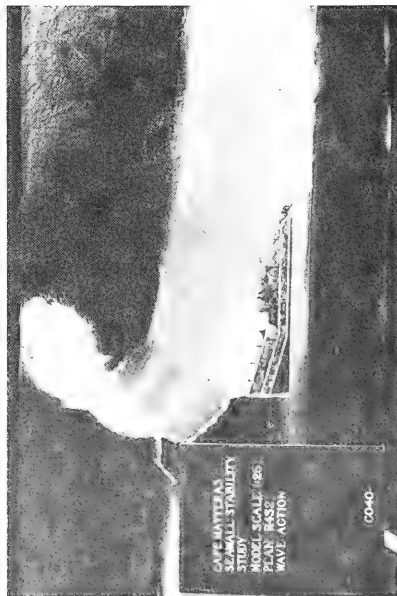

d.

Figure 10. Attack of a 14-sec, 11.4-ft breaking wave on the recurved seawall (Plan R4S2) at an swl of +8.6 ft

of the same conditions appeared to be less variable. Again, representative waves were chosen for plotting typical pressure distribution profiles. These profiles are shown in Plates 26-41. Those wave conditions for which there is no pressure distribution profile yielded negligible pressure records. The profiles indicate that maximum shock pressures occurred in two particular areas on the face of the seawall. One of these areas was near the swl, as had been observed with testing of Plan R4S1. The other region where maximum shock pressures occurred was near the top of the wall, in the area of the smaller radius of curvature. Again, the greatest shock pressures were observed at +6.9 and +8.6 ft swl with wave periods of 12 and 14 sec.

46. Results indicate that the recurved seawall did not significantly alter the magnitudes or durations of the secondary pressures when compared with results of the vertical seawall. Typical secondary pressures for the more extreme conditions were approximately 5.0 psi or less with durations of approximately 2.5 sec (prototype). The average values for the secondary pressures on the recurved seawall are listed in Table 5.

Plan R4S3 Test Results

47. After pressure tests had been performed and analyzed for Plans R4S1 and R4S2, the most severe water level-wave condition combinations had been established; therefore, upon initiation of tests with the modified recurved seawall, some of the less severe conditions were eliminated from the testing sequence. Also, pressures on the cutoff wall were not measured with Plan R4S3, as it was assumed that these pressures would not be significantly changed by modifications to the top of the seawall. It was also assumed that forces might be quite large on the underside of the 2-ft overhang, due to the role of the overhang in blocking wave runoff along the face of the seawall. Therefore, a transducer was mounted vertically in the overhang section. Figure 5 is a profile sketch of the seawall and transducer locations. A view of the instrumented face of the modified recurved seawall is shown in Figure 11.

48. Results of this test series are presented in Table 6 and Plates 42-52. These results indicate no significant change in the intensity or duration of wave pressures on the seawall face, when compared with corresponding measurements from Plan R4S2. However, the vertical transducer mentioned above did record some relatively large shock pressures, the greatest being 75.25 psi

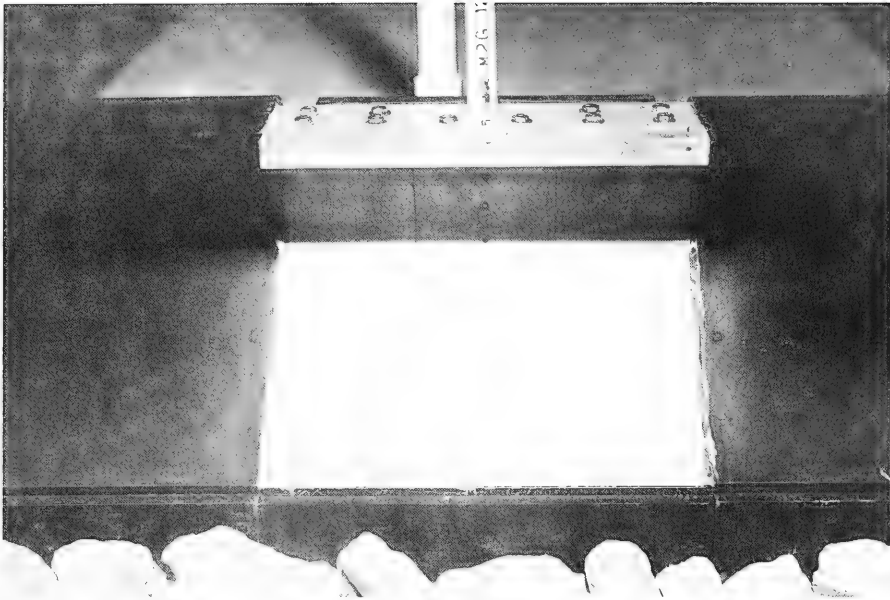

Figure 11. Sea-side view of instrumented recurved seawall face for a 14-sec, 11.4-ft breaking wave at an swl of 8.6 ft msl. Average secondary wave pressures on the modified recurved seawall are listed in Table 7.

49. It was anticipated that further information concerning the magnitudes and durations of the shock pressures would be needed to accomplish final design of the seawall. Therefore, in an effort to provide a temporal distribution of the shock pressures, further data analysis was carried out with test results of Plans R4S2 and R4S3. Pressure records for the 12- and 14-sec waves at +8.6 ft swl were reanalyzed at each transducer location, and nine data samples, distributed as shown below, were obtained for each wave condition.

Samole No.	Time Relative to Peak, sec		Sample No.	Time Relative to Peak, sec	
	Model	Prototype		Model	Prototype
1	-0.100	-0.500	6	0.005	0.025
2	-0.040	-0.200	7	+0.020	+0.100
3	-0.020	-0.100	8	+0.040	+0.100
4	-0.005	-0.025	9	+0.100	+0.500
5	0.000	0.000			

Since the maximum pressures at each transducer rarely all occurred at the same instant in time, the choice of peak condition, or time zero, was subjective. In all cases, that instant at which maximum pressures were occurring at the greatest number of cells was chosen as time zero.

50. Results of this analysis are presented in Tables 8 and 9 and Plates 53-100. These data reinforce the fact that the shock pressure phenomenon is characterized by impulsive loadings and that, especially under extreme wave conditions, the pressure distribution profile can change drastically in a very short time.

51. Comparison of corresponding temporal distributions for Plans R4S2 and R4S3 does not indicate any significant effects due to the difference in the geometric shape of the modified recurve; however, pressure distribution profiles for Plan R4S3 generally show slightly greater pressures near the top of the seawall, due to concentration of wave energy in that area by the 2-ft overhang.

52. On completion of testing, results indicated probable selection of the modified recurved seawall as the most suitable design; however, because of the previously mentioned variability of the shock pressures, SAW requested that additional wave pressure data be collected. Pressures were measured for 100 individual waves (instead of the previous 7 to 12 waves) for the two most critical breaking wave conditions at wave periods of 12 and 14 sec and +8.6 ft swl. This provided sufficient data to allow the execution of a simple statistical analysis.

53. The results of this additional testing are included in Tables 10 and 11. During this test series, provisions were made to increase the sampling rate to 280 samples/sec. This provided a more comprehensive temporal distribution of the wave pressures. Although all pressures for the individual waves listed in Tables 10 and 11 did not occur at the same instant, the time interval over which the maximum pressure occurred at all eight transducers never exceeded 0.43 sec in the prototype. These data again show variability of the shock pressures for consecutive waves of the same conditions and clearly indicate that the maximum pressures occur at the top of the modified recurved seawall. Secondary pressures were consistent throughout the tests. Maximum secondary pressures occurred near +8.6 ft swl and demonstrated typical magnitudes and durations of 5.5 psi and 2.5 sec (prototype), respectively.

PART V: CONCLUSIONS AND DISCUSSION

Conclusions

54. Based on the test results reported herein, it is concluded that:
- a. In regard to revetment stability testing, for the abbreviated and full-length storm-surge hydrographs:
 - (1) Plans R1S1, R2S1, and R3S1 are not acceptable revetment designs.
 - (2) The revetment design incorporated in Plans R4S1, R4S2, and R4S3 is acceptable.
 - (3) Of all wave periods investigated, the 14-sec waves are the most severe in terms of revetment stability.
 - b. In regard to wave pressure testing:
 - (1) Wave pressures observed with the vertical seawall in place were greater than comparable pressures observed with either recurved seawall in place.
 - (2) Wave pressures measured on the cutoff wall decreased when the vertical seawall was replaced by the recurved seawall.
 - (3) Highest wave pressures were observed at +8.6 ft swl.
 - (4) Shock pressures measured on the vertical seawall for apparently identical waves were extremely variable.
 - (5) The variability of shock pressures for seemingly identical waves was reduced with the recurved and modified recurved seawalls in place.
 - (6) With the vertical seawall in place, the greatest shock pressures were measured near the swl.
 - (7) With the recurved seawall in place, the greatest shock pressures were measured near the swl and near the region of the smaller radius of curvature.
 - (8) With the modified recurved seawall in place, the greatest shock pressures were measured on the lower face of the 2-ft overhang.
 - (9) Wall geometry had no significant effect on the magnitude or duration of the secondary pressures.
 - (10) The modified recurved seawall was the most suitable design tested in terms of minimizing pressures on the face of the wall and reducing runup and overtopping.

Discussion

55. Results of this model study indicate that Plan R4S3 is the most

suitable design of all alternatives tested. The revetment section with its 6.3-ton primary armor stone demonstrated a favorable stability response when subjected to the most severe wave and water level conditions expected in the prototype. Also, there was no indication of problems related to the interaction and combined stability of the seawall and revetment. The seawall curvature proposed by SAW was found acceptable in minimizing wave forces when compared with the vertical wall; however, a structural modification to the crown of the recurved seawall was included in the final design. This modification eliminated wave overtopping for all but the most severe water level and wave conditions.

REFERENCES

- Bagnold, R. A. 1939. "Interim Report on Wave-Pressure Research," Journal, Institution of Civil Engineers, Vol 12, No. 7, pp 202-226.
- Carr, J. H. 1954. "Breaking Wave Forces on Plane Barriers," Report E-11.3, Hydrodynamics Laboratory, California Institute of Technology, Pasadena, Calif.
- Garcia, W. J. 1968. "An Experimental Study of Breaking Wave Pressures," Research Report H-68-1, US Army Engineer Waterways Experiment Station, Vicksburg, Miss.
- Hudson, R. Y. 1975. "Reliability of Rubble-Mound Breakwater Stability Models," Miscellaneous Paper H-75-5, US Army Engineer Waterways Experiment Station, Vicksburg, Miss.
- Kamel, A. M. 1968a. "Shock Pressures Caused by Waves Breaking Against Coastal Structures," Research Report H-68-2, US Army Engineer Waterways Experiment Station, Vicksburg, Miss.
- _____. 1968b. "Water Wave Pressures on Seawalls and Breakwaters," Research Report 2-10, US Army Engineer Waterways Experiment Station, Vicksburg, Miss.
- Minikin, R. R. 1946. "Pressure of Breaking Waves," The Dock and Harbour Authority, Vol 26, pp 262-266.
- Stevens, J. C., et al. 1942. "Hydraulic Models," Manuals on Engineering Practice No. 25, American Society of Civil Engineers, New York.

Table 1

Wave Conditions Used For Pressure Tests

swl ft	Incident Wave		Wave Form
	T, sec	H, ft	
+2.6	6.0	9.0	Breaking
	8.0	11.1	Breaking
	10.0	11.0	Breaking
	12.0	12.6	Breaking
	14.0	12.7	Breaking
+4.3	6.0	11.5	Breaking
	8.0	13.1	Breaking
	10.0	12.8	Breaking
	12.0	12.7	Breaking
	14.0	13.1	Breaking
+6.9	6.0	10.7	Breaking
	8.0	13.4	Breaking
	10.0	14.0	Nonbreaking
	10.0	14.7	Nonbreaking
	10.0	15.7	Breaking
	12.0	12.0	Nonbreaking
	12.0	14.0	Nonbreaking
	12.0	16.0	Breaking
	12.0	13.3	Prebreaking
	14.0	12.0	Nonbreaking
	14.0	14.0	Nonbreaking
	14.0	16.3	Breaking
	14.0	11.2	Prebreaking
+8.6	6.0	12.5	Breaking
	8.0	14.1	Breaking
	10.0	12.1	Nonbreaking
	10.0	14.8	Nonbreaking
	10.0	15.8	Breaking
	12.0	12.0	Nonbreaking
	12.0	14.0	Nonbreaking
	12.0	16.8	Breaking
	12.0	16.0	Prebreaking
	14.0	12.0	Nonbreaking
	14.0	14.0	Nonbreaking
	14.0	17.0	Breaking
	14.0	11.4	Prebreaking

Table 2
Shock Pressure Data, Test Series 1, Plan R4S1

Wave No.	Shock Pressure, psi, at Indicated Elevation, ft											
	+22	+20	+18	+16	+14	+12	+10	+8	+6.5	+1.0	-1.5	-4.0
1	*	*	*	*	*	*	*	*	*	*	*	*
2	*	*	*	*	*	*	*	*	*	*	*	*
3	*	*	*	*	*	*	*	*	*	*	*	*
4	*	*	*	*	*	*	*	*	*	*	*	*
5	*	*	*	*	*	*	*	*	*	*	*	*
6	*	*	*	*	*	*	*	*	*	*	*	*
7	*	*	*	*	*	*	*	*	*	*	*	*
<u>swl = 2.6 ft; T = 6 sec; H = 9.0 ft</u>												
1	*	*	*	*	*	*	*	*	*	*	*	*
2	*	*	*	*	*	*	*	*	*	*	*	*
3	*	*	*	*	*	*	*	*	*	*	*	*
4	*	*	*	*	*	*	*	*	*	*	*	*
5	*	*	*	*	*	*	*	*	*	*	*	*
6	*	*	*	*	*	*	*	*	*	*	*	*
7	*	*	*	*	*	*	*	*	*	*	*	*
<u>swl = 2.6 ft; T = 8 sec; H = 11.1 ft</u>												
1	*	*	*	*	*	*	*	*	*	*	*	*
2	*	*	*	*	*	*	*	*	*	*	*	*
3	*	*	*	*	*	*	*	*	*	*	*	*
4	*	*	*	*	*	*	*	*	*	*	*	*
5	*	*	*	*	*	*	*	*	*	*	*	*
6	*	*	*	*	*	*	*	*	*	*	*	*
7	*	*	*	*	*	*	*	*	*	*	*	*
8	*	*	*	*	*	*	*	*	*	*	*	*
9	*	*	*	*	*	*	*	*	*	*	*	*
10	*	*	*	*	*	*	*	*	*	*	*	*
Avg												
Max												
Min												

(Continued)

* Negligible.

Table 2 (Continued)

Wave No.	Shock Pressure, psi, at Indicated Elevation, ft											
	+22	+20	+18	+16	+14	+12	+10	+8	+6.5	+1.0	-1.5	-4.0
<u>swl = 2.6 ft; T = 10 sec; H = 11.0 ft</u>												
1	*	*	*	*	*	*	*	9.75	8.50	6.75	6.50	16.25
2	*	*	*	*	*	*	*	8.75	32.25	6.75	6.50	19.50
3	*	*	*	*	*	*	*	6.50	32.25	5.50	6.50	19.50
4	*	*	*	*	*	*	*	7.75	9.75	5.50	5.50	8.50
5	*	*	*	*	*	*	*	9.75	28.00	5.50	6.50	16.25
6	*	*	*	*	*	*	*	18.75	13.00	6.75	7.50	14.00
7	*	*	*	*	*	*	*	13.25	13.00	7.75	7.50	18.25
8	*	*	*	*	*	*	*	6.50	13.00	7.75	7.50	9.75
9	*	*	*	*	*	*	*	6.50	8.50	7.75	7.50	13.00
10	*	*	*	*	*	*	*	4.50	17.25	6.75	8.50	17.25
AVG								9.2	17.6	6.7	7.0	15.2
Max								18.75	32.25	7.75	8.50	19.50
Min								4.50	8.50	5.50	5.50	8.50
<u>swl = 2.6 ft; T = 12 sec; H = 12.6 ft</u>												
1	*	*	*	*	*	*	*	9.75	14.00	9.00	10.75	19.50
2	*	*	*	*	*	*	*	19.75	22.75	9.00	9.75	17.25
3	*	*	*	*	*	*	*	22.00	19.50	10.00	10.75	21.50
4	*	*	*	*	*	*	*	26.25	18.25	11.25	13.00	17.25
5	*	*	*	*	*	*	*	8.75	11.75	10.00	15.00	45.25
6	*	*	*	*	*	*	*	14.25	22.75	11.25	11.75	24.75
7	*	*	*	*	*	*	*	17.50	17.75	12.25	14.00	31.25

(Continued)

* Negligible.

Table 2 (Continued)

Wave No.	Shock Pressure, psi, at Indicated Elevation, ft											
	+22	+20	+18	+16	+14	+12	+10	+8	+6.5	+1.0	-1.5	-4.0
8	*	*	*	*	*	*	*	13.25	11.75	10.00	11.75	17.25
9	*	*	*	*	*	*	*	13.25	22.75	11.25	13.00	18.25
10	*	*	*	*	*	*	*	14.25	31.25	11.25	11.75	19.50
Avg								15.9	19.25	10.5	12.2	23.2
Max								26.25	31.25	12.25	15.00	45.25
Min								8.75	11.75	9.00	9.75	17.25
<u>swl = 2.6 ft; T = 12 sec; H = 12.6 ft (Continued)</u>												
1	*	*	*	*	*	*	*	16.50	20.50	10.00	10.75	15.00
2	*	*	*	*	*	*	*	15.25	30.25	13.50	17.25	23.75
3	*	*	*	*	*	*	*	23.00	33.50	11.25	10.75	17.25
4	*	*	*	*	*	*	*	11.00	39.75	13.50	15.00	27.00
5	*	*	*	*	*	*	*	12.00	17.25	13.50	15.00	16.25
6	*	*	*	*	*	*	*	13.25	13.00	12.25	14.00	18.25
7	*	*	*	*	*	*	*	13.25	20.50	12.25	13.00	23.75
8	*	*	*	*	*	*	*	12.00	19.50	12.25	15.00	19.50
9	*	*	*	*	*	*	*	28.50	29.00	11.25	15.00	22.75
10	*	*	*	*	*	*	*	14.25	15.00	10.00	13.00	20.50
Avg								15.9	23.8	12.0	13.9	20.4
Max								28.50	39.75	13.50	17.25	27.00
Min								11.00	13.00	10.00	10.75	15.00
(Continued)												

* Negligible.

Table 2 (Continued)

Wave No.	Shock Pressure, psi, at Indicated Elevation, ft											
	+22	+20	+18	+16	+14	+12	+10	+8	+6.5	+1.0	-1.5	-4.0
1	*	*	*	*	*	*	*	5.50	35.50	5.50	6.50	7.50
2	*	*	*	*	*	*	*	5.50	17.25	7.75	6.50	7.50
3	*	*	*	*	*	*	*	3.25	7.50	5.50	6.50	5.50
4	*	*	*	*	*	*	*	5.50	10.75	7.75	7.50	7.50
5	*	*	*	*	*	*	*	5.50	16.25	5.50	6.50	6.50
6	*	*	*	*	*	*	*	5.50	16.25	7.75	6.50	6.50
7	*	*	*	*	*	*	*	7.25	13.00	6.75	6.50	5.50
8	*	*	*	*	*	*	*	8.75	13.00	5.50	6.50	5.50
9	*	*	*	*	*	*	*	5.50	7.50	5.50	6.50	6.50
10	*	*	*	*	*	*	*	5.50	9.75	5.50	5.50	6.50
Avg								5.8	14.7	6.3	6.5	6.5
Max								8.75	35.50	7.75	7.50	7.50
Min								3.25	7.50	5.50	5.50	5.50

<u>swl = 4.3 ft; T = 6 sec; H = 11.5 ft</u>												
1	2.00	0.25	0.75	0.50	1.50	1.25	12.75	43.50	70.00	9.75	10.75	13.00
2	0.75	0.25	0.75	0.50	0.75	4.25	7.50	13.00	52.75	8.75	8.50	8.50
3	0.25	0.00	0.50	0.25	0.75	1.50	5.25	10.75	22.75	3.00	3.00	3.00
4	0.25	0.00	1.25	0.50	0.75	2.00	3.25	4.25	11.75	5.50	4.25	4.25
5	0.25	0.00	0.50	0.25	0.75	1.00	4.25	7.50	9.75	4.50	4.25	4.25
6	0.25	0.00	0.75	0.75	0.50	0.75	2.25	13.00	25.75	4.50	4.25	5.00
7	1.25	0.00	0.75	0.50	1.00	1.25	1.75	4.25	9.75	3.25	3.25	3.50

swl = 4.3 ft; T = 8 sec; H = 13.1 ft

(Continued)

* Negligible.

Table 2 (Continued)

Wave No.	Shock Pressure, psi, at Indicated Elevation, ft											
	+22	+20	+18	+16	+14	+12	+10	+8	+6.5	+1.0	-1.5	-4.0
8	2.00	0.50	0.75	0.75	5.25	3.00	7.50	12.00	21.50	7.75	8.50	9.75
9	1.50	0.00	1.00	2.00	1.00	1.75	3.25	6.50	11.75	4.50	4.25	4.25
10	0.50	0.25	1.00	0.50	1.00	1.25	2.25	6.50	9.75	4.50	4.25	4.50
Avg	0.9	0.1	0.8	0.6	1.3	1.8	5.0	12.1	24.6	5.6	5.5	6.00
Max	2.00	0.50	1.25	2.00	5.25	4.25	12.75	43.50	70.00	9.75	10.75	13.00
Min	0.25	0.00	0.50	0.25	0.50	0.75	1.75	4.25	9.75	3.25	3.00	3.00
<u>swl = 4.3 ft; T = 8 sec; H = 13.1 ft (Continued)</u>												
<u>swl = 4.3 ft; T = 10 sec; H = 12.8 ft</u>												
1	0.50	0.25	0.25	0.25	1.50	3.25	4.75	7.50	8.50	5.50	5.25	6.75
2	0.50	0.25	0.25	0.25	1.50	1.75	7.50	16.25	28.00	11.00	12.75	14.00
3	1.00	0.00	0.25	0.25	1.25	3.25	4.25	7.50	9.75	7.75	8.50	8.50
4	2.00	0.50	1.00	0.50	1.50	3.25	7.50	13.00	22.75	9.75	10.75	11.75
5	1.75	0.50	0.50	0.75	2.00	4.25	8.50	14.25	21.50	11.00	10.75	11.75
6	1.50	0.75	1.25	0.50	2.00	2.75	9.50	19.50	17.50	11.00	10.75	11.75
7	1.50	0.50	1.25	0.50	1.75	3.00	6.50	16.25	21.50	9.75	9.50	9.75
8	2.50	0.50	1.25	0.75	1.75	3.50	6.50	9.75	25.75	9.75	9.50	10.75
9	1.25	1.25	1.50	0.75	2.25	3.50	8.50	13.00	21.50	12.00	12.75	14.00
10	2.75	1.25	1.50	0.75	2.25	3.50	6.50	15.25	22.75	11.00	11.75	14.00
Avg	1.5	0.6	0.9	0.5	1.8	3.2	7.00	13.2	20.0	9.8	10.2	11.3
Max	2.75	1.25	1.50	0.75	2.25	4.25	9.50	19.50	28.00	12.00	12.75	14.00
Min	0.50	0.00	0.25	0.25	1.25	1.75	4.25	7.50	8.50	5.50	5.25	6.75

(Continued)

Table 2 (Continued)

Wave No.	Shock Pressure, psi, at Indicated Elevation, ft											
	+22	+20	+18	+16	+14	+12	+10	+8	+6.5	+1.0	-1.5	-4.0
1	6.25	0.75	1.00	1.25	2.50	3.50	7.50	17.50	29.00	9.75	10.75	10.75
2	0.50	1.50	1.00	1.50	10.50	3.75	15.00	19.50	32.25	14.25	15.00	15.00
3	2.00	1.25	2.25	1.50	2.25	3.75	9.50	15.25	39.75	11.00	11.75	9.75
4	0.50	0.50	2.25	2.75	2.50	6.50	12.75	26.00	39.75	13.25	14.00	17.25
5	3.00	1.00	2.00	1.50	2.50	5.50	11.75	124.00	45.25	15.25	17.00	27.00
6	2.25	1.50	1.75	1.50	2.75	4.50	10.75	16.25	59.25	13.25	14.00	16.25
7	2.75	1.75	1.75	2.00	2.75	4.50	9.50	21.75	76.50	18.75	19.25	22.75
Avg	2.5	1.2	1.9	1.7	3.7	4.6	11.0	34.3	46.0	13.6	14.5	17.0
Max	6.25	1.75	2.25	2.75	10.50	6.50	15.00	124.00	76.50	18.75	19.25	27.00
Min	0.50	0.50	1.00	1.25	2.25	3.50	7.50	15.25	29.00	9.75	10.75	9.75
<u>swl = 4.3 ft; T = 14 sec; H = 13.1 ft</u>												
1	1.25	0.50	1.00	1.75	3.25	5.50	5.00	8.75	11.75	5.50	5.25	6.00
2	2.00	0.25	1.25	1.00	1.75	5.50	10.75	10.75	31.25	9.75	9.50	8.50
3	1.00	0.75	1.75	1.75	3.50	3.25	5.00	9.75	15.00	7.75	6.50	6.75
4	1.25	0.50	2.00	7.25	3.25	11.00	18.25	19.25	20.50	11.00	11.75	11.75
5	2.00	0.75	2.25	1.75	3.25	4.00	25.75	13.00	18.25	7.75	7.50	5.50
6	1.75	0.75	2.00	1.50	3.00	6.50	6.50	12.00	19.50	7.75	8.50	5.50
7	2.00	1.00	2.25	2.75	3.25	5.75	8.50	20.75	29.00	8.75	9.50	8.50
Avg	1.6	0.6	1.8	2.5	3.0	5.9	11.4	13.5	20.8	8.3	8.4	7.5
Max	2.00	1.00	2.25	7.25	3.50	11.00	25.75	20.75	29.00	11.00	11.75	11.75
Min	1.00	0.25	1.00	1.00	1.75	3.25	5.00	8.75	11.75	5.50	5.25	5.50

(Continued)

Table 2 (Continued)

Wave No.	Shock Pressure, psi, at Indicated Elevation, ft											
	+22	+20	+18	+16	+14	+12	+10	+8	+6.5	+1.0	-1.5	-4.0
1	0.50	0.50	0.75	0.75	0.75	1.00	8.50	9.75	13.00	3.50	3.75	5.50
2	0.75	0.50	0.75	0.75	1.00	2.25	4.00	6.50	11.75	2.50	2.50	2.50
3	0.50	0.75	0.50	0.75	1.75	6.50	24.50	21.75	21.50	11.00	10.75	14.00
4	0.50	0.50	0.50	0.75	1.50	3.50	14.00	27.25	23.75	6.50	7.50	7.50
5	0.50	0.50	0.50	0.50	1.25	2.00	3.50	4.25	13.00	3.00	3.50	4.25
6	1.00	1.50	0.75	0.50	1.25	3.25	6.50	6.50	17.25	5.50	5.75	4.25
7	1.25	0.50	1.00	0.75	1.75	2.25	5.25	7.50	10.75	4.00	4.50	4.75
8	1.25	0.50	1.00	0.75	2.25	3.25	3.25	24.00	10.75	3.00	3.50	3.50
9	1.50	0.50	1.00	1.00	3.50	7.00	20.50	15.25	11.75	4.50	5.25	5.50
10	0.75	0.75	1.50	1.75	3.75	11.00	16.00	16.25	17.25	5.50	5.25	7.50
11	1.75	0.75	1.00	1.00	1.75	2.75	5.00	17.50	18.25	3.25	3.50	3.75
12	1.25	1.50	1.25	1.00	2.75	7.75	16.00	22.75	30.25	5.50	6.50	7.50
Avg	1.0	0.7	0.9	0.9	1.9	4.4	10.6	14.9	16.6	4.8	5.2	5.9
Max	1.75	1.50	1.50	1.75	3.75	11.0	24.50	27.25	30.25	11.0	10.75	14.00
Min	0.50	0.50	0.50	0.50	0.75	1.00	3.25	4.25	10.75	2.50	2.50	2.50
<u>swl = 6.9 ft; T = 8 sec; H = 13.4 ft</u>												
1	0.75	1.25	1.75	3.50	2.75	16.50	48.00	20.75	22.75	15.25	10.50	18.25
2	0.75	0.75	1.25	3.50	3.75	11.00	30.00	43.50	69.50	19.75	16.00	28.00
3	0.75	1.75	1.00	4.50	2.75	7.75	17.00	67.50	95.75	9.75	11.75	14.00
4	0.75	0.75	1.25	4.25	4.25	9.75	22.50	47.75	110.75	12.00	16.00	16.25
5	1.50	1.50	1.00	2.75	4.25	12.00	27.75	49.00	77.25	15.25	16.00	16.25
6	1.00	1.25	1.75	2.00	5.25	14.25	17.00	55.50	56.50	11.00	14.75	15.00

(Continued)

Table 2 (Continued)

Wave No.	Shock Pressure, psi, at Indicated Elevation, ft											
	+22	+20	+18	+16	+14	+12	+10	+8	+6.5	+1.0	-1.5	-4.0
	<u>swl = 6.9 ft; T = 8 sec; H = 13.4 ft (Continued)</u>											
7	1.50	1.25	1.75	3.50	5.25	12.00	23.50	80.50	47.75	12.00	31.75	8.50
8	1.25	1.00	1.75	2.00	5.25	18.75	31.00	33.75	35.75	17.50	12.75	21.50
9	1.25	1.75	2.00	4.25	7.50	18.75	23.50	37.00	33.75	15.25	12.75	18.25
10	1.50	1.00	1.75	2.75	4.25	9.75	24.50	31.50	30.50	16.50	12.75	16.25
	<u>swl = 6.9 ft; T = 10 sec; H = 14.0 ft</u>											
Avg	1.1	1.2	1.4	3.3	4.5	13.0	26.5	46.7	58.0	14.4	15.5	17.2
Max	1.50	1.75	2.00	4.50	7.50	18.75	48.00	80.50	110.75	19.75	31.75	28.00
Min	0.75	0.75	1.00	2.00	2.75	9.75	17.00	20.75	22.75	9.75	10.50	8.50
	<u>swl = 6.9 ft; T = 10 sec; H = 14.0 ft</u>											
1	1.00	1.00	1.00	1.25	2.75	7.75	10.75	21.75	21.50	7.75	8.50	7.50
2	1.25	1.25	3.75	2.00	3.50	6.50	12.75	68.50	20.25	16.50	17.00	21.50
3	1.00	0.75	1.00	1.75	3.25	5.50	7.50	12.00	17.25	7.50	7.50	8.50
4	1.25	1.00	1.00	1.75	3.25	5.50	7.50	12.00	17.25	11.00	11.75	13.00
5	1.25	0.75	1.25	2.00	3.50	6.50	10.75	43.50	32.25	12.00	11.75	11.75
6	1.50	1.00	1.50	2.25	4.25	6.50	10.75	15.25	21.50	16.50	17.00	17.25
7	1.50	0.75	1.50	2.00	4.00	5.50	7.50	17.50	32.25	8.75	9.50	8.50
8	1.50	1.00	1.50	2.25	3.75	5.50	10.75	26.00	20.50	7.75	8.50	6.50
	<u>swl = 6.9 ft; T = 10 sec; H = 14.0 ft</u>											
Avg	1.3	0.9	1.6	1.9	3.5	6.2	9.8	27.1	22.8	11.0	11.4	11.8
Max	1.50	1.25	3.75	2.25	4.25	7.75	12.75	68.50	32.25	16.50	17.00	21.50
Min	1.00	0.75	1.00	1.25	2.75	5.50	7.50	12.00	17.25	7.75	7.50	6.50

(Continued)

(Sheet 8 of 23)

Table 2 (Continued)

Wave No.	Shock Pressure, psi, at Indicated Elevation, ft											
	+22	+20	+18	+16	+14	+12	+10	+8	+6.5	+1.0	-1.5	-4.0
	<u>swl = 6.9 ft; T = 10 sec; H = 14.7 ft</u>											
1	0.50	0.75	1.25	1.50	3.00	5.75	10.75	16.25	24.75	8.75	8.50	8.50
2	0.75	1.25	1.25	2.00	4.25	7.00	15.00	37.00	59.25	22.00	24.50	31.25
3	0.75	1.25	1.50	2.00	3.75	4.50	8.50	16.25	21.50	8.75	8.50	7.50
4	1.25	1.00	1.25	2.00	3.50	6.25	10.75	24.00	23.75	16.50	16.00	17.25
5	1.25	1.25	1.75	2.50	4.00	7.75	15.25	24.00	25.75	15.25	16.00	16.25
6	1.25	1.00	1.75	2.25	3.50	6.75	11.75	20.75	31.25	17.50	19.25	21.50
7	1.50	1.00	2.50	2.25	4.00	7.00	8.50	38.00	32.25	8.75	8.50	8.50
8	1.50	1.25	2.50	2.75	4.50	4.50	10.75	21.75	22.75	8.75	9.50	10.75
AVG	1.1	1.1	1.7	2.2	3.8	6.2	11.4	24.8	30.2	13.3	13.8	15.2
Max	1.50	1.25	2.50	2.75	4.50	7.75	15.25	38.00	59.25	22.00	24.50	31.25
Min	0.50	0.75	1.25	1.50	3.00	4.50	8.50	16.25	21.50	8.75	8.50	7.50
	<u>swl = 6.9 ft; T = 10 sec; H = 15.7 ft</u>											
1	3.00	2.25	1.75	2.00	4.25	9.75	27.75	32.50	34.75	16.50	17.00	18.25
2	1.50	1.50	1.75	2.00	4.25	12.00	18.25	18.50	22.75	13.25	14.00	16.25
3	2.75	2.50	2.75	8.50	7.50	17.50	37.50	27.25	40.25	34.00	38.50	47.50
4	1.50	2.00	2.25	4.00	8.50	7.75	11.75	27.25	45.75	8.75	8.50	9.75
5	3.25	1.00	2.25	2.00	4.25	7.75	33.00	21.75	31.75	11.00	10.75	10.75
6	3.00	1.25	2.50	2.50	5.25	6.50	11.75	21.75	50.00	11.00	10.75	10.75
7	3.00	0.75	2.25	2.00	5.25	6.50	11.75	25.00	44.50	12.00	10.75	11.75

(Continued)

Table 2 (Continued)

Wave No.	Shock Pressure, psi, at Indicated Elevation, ft											
	+22	+20	+18	+16	+14	+12	+10	+8	+6.5	+1.0	-1.5	-4.0
8	2.25	1.00	2.25	4.50	4.25	9.75	12.75	21.75	33.75	14.25	15.00	17.25
9	2.50	2.25	2.25	4.50	6.25	12.00	15.00	15.25	16.25	12.00	11.75	17.25
Avg	2.5	1.6	2.2	3.6	5.5	9.9	19.9	23.4	35.5	14.8	15.2	17.7
Max	3.25	2.5	2.75	8.50	8.50	17.50	37.50	32.50	50.00	34.00	38.50	47.50
Min	1.50	0.75	1.75	2.00	4.25	6.50	11.75	15.25	16.25	8.75	8.50	9.75
<u>swl = 6.9 ft; T = 10 sec; H = 15.7 ft (Continued)</u>												
<u>swl = 6.9 ft; T = 12 sec; H = 12.0 ft</u>												
1	3.00	0.75	0.75	3.50	2.50	4.25	5.25	29.25	40.25	4.50	5.25	6.00
2	0.75	0.75	0.75	4.75	2.50	4.25	7.50	32.50	90.25	7.75	9.50	10.75
3	0.50	1.00	1.25	6.25	4.25	4.25	12.75	63.00	71.75	29.50	34.25	43.00
4	2.75	2.00	1.25	2.75	2.50	4.25	10.75	43.50	38.00	27.50	33.00	43.00
5	2.00	0.75	1.00	2.00	2.50	4.50	16.00	92.50	70.75	22.00	24.50	31.25
6	2.50	1.50	1.75	2.75	6.25	7.75	18.25	39.25	38.00	20.75	24.50	30.25
7	1.00	1.00	2.50	1.50	3.00	6.50	14.00	38.00	53.25	14.25	16.00	16.25
8	4.00	2.00	2.50	3.50	8.50	9.75	31.00	92.50	35.75	17.50	20.25	23.75
Avg	2.1	1.2	1.5	3.4	4.0	5.7	14.4	53.8	54.8	18.0	20.9	25.5
Max	4.00	2.00	2.50	6.25	8.50	9.75	31.00	92.50	90.25	29.50	34.25	43.00
Min	0.50	0.75	0.75	1.50	2.50	4.25	5.25	29.25	35.75	4.50	5.25	6.00

(Continued)

Table 2 (Continued)

Wave No.	Shock Pressure, psi, at Indicated Elevation, ft											
	+22	+20	+18	+16	+14	+12	+10	+8	+6.5	+1.0	-1.5	-4.0
1	1.00	1.50	1.00	2.00	5.25	3.25	8.50	27.25	46.25	7.75	9.50	11.75
2	2.00	1.25	1.25	2.50	5.25	6.50	11.75	15.25	26.00	9.75	10.75	10.75
3	2.25	1.00	1.50	2.75	4.25	5.50	14.00	77.25	107.50	27.50	32.00	39.75
4	1.00	2.00	1.75	2.75	6.25	39.50	48.00	49.00	87.00	23.00	25.75	31.25
5	1.75	1.00	2.00	2.00	3.25	5.50	26.75	56.50	63.00	23.00	26.75	32.25
6	1.25	2.25	5.25	4.75	6.25	11.00	24.50	130.50	153.25	17.50	19.25	23.75
7	2.00	3.25	3.75	7.25	7.50	5.50	12.75	64.25	135.75	14.25	16.00	19.50
8	1.75	5.25	28.75	13.50	12.75	16.50	26.75	38.00	43.50	20.75	21.25	28.00
Avg	1.6	2.2	5.7	4.7	6.3	11.7	21.6	57.2	82.8	17.9	20.2	24.6
Max	2.25	5.25	28.75	13.50	12.75	39.50	48.00	130.50	153.25	27.50	32.00	39.75
Min	1.00	1.00	1.00	2.00	3.25	3.25	8.50	15.25	26.00	7.75	9.50	11.75

swl = 6.9 ft; T = 12 sec; H = 14.0 ft

swl = 6.9 ft; T = 12 sec; H = 16.0 ft

1	1.50	2.00	1.75	2.50	5.25	9.75	17.00	31.50	34.50	13.25	15.00	18.25
2	3.75	3.00	1.75	4.00	6.25	12.00	20.25	22.75	29.00	14.25	15.00	15.00
3	1.25	1.25	1.50	2.75	4.25	17.50	37.50	121.75	101.25	23.00	24.50	30.25
4	2.00	2.00	3.50	6.75	8.50	11.00	30.00	74.00	129.25	28.50	32.00	36.75
5	2.75	2.75	2.50	8.75	16.00	12.00	90.75	97.75	75.50	31.75	35.25	43.00
6	5.50	4.25	8.25	6.50	8.50	16.50	31.00	90.25	80.75	19.75	21.25	25.75

(Continued)

(Sheet 11 of 23)

Table 2 (Continued)

Wave No.	Shock Pressure, psi, at Indicated Elevation, ft											
	+22	+20	+18	+16	+14	+12	+10	+8	+6.5	+1.0	-1.5	-4.0
<u>swl = 6.9 ft; T = 12 sec; H = 16.0 ft (Continued)</u>												
7	2.00	1.00	3.25	4.50	7.50	13.25	40.50	89.25	80.75	26.25	27.75	33.50
8	2.00	2.00	2.25	4.75	6.25	11.00	25.75	43.50	46.25	22.00	22.50	28.00
Avg	2.6	2.3	3.1	5.1	7.8	12.9	36.6	71.3	72.2	22.3	24.2	28.8
Max	5.50	4.25	8.25	8.75	16.00	17.50	90.75	121.75	129.25	31.75	35.25	43.00
Min	1.25	1.00	1.50	2.50	4.25	9.75	17.00	22.75	29.00	13.25	15.00	15.00
<u>swl = 6.9 ft; T = 12 sec; H = 13.3 ft</u>												
1	3.50	2.75	1.75	4.50	6.25	12.00	26.75	34.75	78.75	16.50	17.00	19.50
2	4.25	5.25	5.50	8.00	17.00	42.75	44.75	47.75	72.25	31.75	34.25	38.75
3	4.50	5.25	6.50	14.75	23.25	27.50	46.00	108.75	59.25	24.00	25.75	27.00
4	2.00	2.00	2.25	5.25	12.75	59.25	53.00	65.25	59.25	30.75	33.00	36.75
5	3.75	3.75	6.00	10.50	26.50	41.75	53.00	126.00	64.75	28.50	31.00	34.50
6	1.50	1.00	1.75	4.75	6.25	12.00	17.00	19.50	21.50	8.75	8.50	9.75
7	3.75	2.25	3.00	4.75	7.50	11.00	17.00	40.25	49.50	11.00	11.75	10.75
8	2.50	2.25	3.00	6.00	11.75	17.50	27.75	34.75	31.25	13.25	16.00	16.25
Avg	3.2	3.1	3.7	7.3	11.00	28.0	35.7	59.6	54.6	20.6	22.2	24.2
Max	4.50	5.25	6.50	14.75	26.50	59.25	53.00	126.00	78.75	31.75	34.25	38.75
Min	1.50	1.00	1.75	4.50	6.25	11.00	17.00	19.50	21.50	8.75	8.50	9.75

(Continued)

(Sheet 12 of 23)

Table 2 (Continued)

Wave No.	Shock Pressure, psi, at Indicated Elevation, ft											
	+22	+20	+18	+16	+14	+12	+10	+8	+6.5	+1.0	-1.5	-4.0
<u>swl = 6.9 ft; T = 14 sec; H = 12.0 ft</u>												
1	4.00	1.00	2.50	2.50	4.25	6.50	28.75	43.50	66.75	15.25	17.00	22.75
2	3.50	1.50	2.00	3.25	6.25	8.75	31.00	49.00	43.00	13.25	15.00	16.25
3	5.75	2.25	2.50	4.00	4.25	12.00	42.00	35.75	38.75	12.00	15.00	17.25
4	2.75	1.00	2.25	3.25	4.25	9.75	72.00	130.50	71.00	16.50	19.25	21.75
5	1.25	2.00	2.50	3.50	5.25	11.00	24.50	27.25	39.75	14.00	14.00	16.25
6	2.75	2.25	2.50	2.75	5.25	9.75	18.25	15.50	44.25	12.00	15.00	17.25
7	1.50	1.00	2.25	3.25	6.25	16.50	33.00	22.75	29.00	9.75	11.75	14.00
Avg	3.1	1.6	2.4	3.2	5.1	10.6	32.2	46.3	47.5	13.0	15.3	17.9
Max	5.75	2.25	2.50	4.00	6.25	16.50	72.75	130.50	71.00	16.50	19.25	22.75
Min	1.25	1.00	2.25	2.50	4.25	6.50	17.00	15.50	38.75	9.75	11.75	14.00
<u>swl = 6.9 ft; T = 14 sec; H = 14.0 ft</u>												
1	1.50	1.00	1.75	2.75	5.25	13.25	35.25	59.75	59.25	18.75	21.25	25.75
2	2.00	1.25	1.75	4.00	7.50	11.00	41.75	25.00	42.00	12.00	12.75	16.25
3	1.75	2.00	1.75	4.75	7.50	19.75	32.00	26.00	41.00	11.00	12.75	16.25
4	2.75	1.50	2.25	4.75	6.25	9.75	32.00	133.75	64.75	15.25	19.25	24.75
5	2.75	1.50	2.25	4.50	8.50	11.00	11.75	20.75	54.00	11.00	10.75	10.75
6	5.25	2.00	3.50	7.25	9.50	11.00	17.00	16.25	28.00	9.75	10.75	10.75
7	2.75	1.50	2.50	4.50	6.25	9.75	25.75	38.00	58.25	12.00	12.75	14.00
Avg	2.7	1.5	2.2	4.6	7.25	12.2	27.9	45.6	49.6	12.8	14.3	16.9
Max	5.25	2.00	3.50	7.25	8.50	19.75	41.75	133.75	64.75	18.75	21.25	25.75
Min	1.50	1.00	1.75	2.75	5.25	9.75	11.75	16.25	28.00	9.75	10.75	10.75

(Continued)

Table 2 (Continued)

Wave No.	Shock Pressure, psi, at Indicated Elevation, ft											
	+22	+20	+18	+16	+14	+12	+10	+8	+6.5	+1.0	-1.5	-4.0
<u>swl = 6.9 ft; T = 14 sec; H = 16.3 ft</u>												
1	3.00	1.50	2.25	5.50	7.50	19.75	42.75	144.50	103.25	17.50	19.25	22.75
2	3.00	2.25	2.50	6.00	14.75	17.50	39.50	85.75	112.00	15.25	17.00	21.50
3	4.50	2.25	4.75	8.75	19.00	20.75	22.50	21.75	29.00	13.25	12.75	14.00
4	5.75	3.00	4.75	11.25	16.00	17.50	33.00	102.25	86.25	19.75	22.50	28.00
5	4.50	2.50	5.50	12.00	25.50	23.00	20.25	17.50	35.50	14.25	14.00	13.00
6	17.00	2.25	3.75	10.75	16.00	15.25	21.25	21.75	33.50	13.25	11.75	13.00
7	4.25	2.25	3.50	11.50	17.00	23.00	21.25	20.75	57.00	13.25	14.00	14.00
<u>swl = +6.9 ft; T = 14 sec; H = 11.2 ft</u>												
AVG	6.00	2.3	3.9	9.4	16.5	19.5	28.6	59.2	65.2	15.2	15.9	18.0
Max	17.00	3.00	5.50	12.00	25.50	23.00	42.75	144.50	112.00	19.75	22.50	28.00
Min	3.00	1.50	2.25	5.50	7.50	15.25	20.25	17.50	29.00	13.25	11.75	13.00
<u>swl = +6.9 ft; T = 14 sec; H = 11.2 ft</u>												
1	2.75	4.50	7.25	10.00	14.75	39.50	37.50	163.00	81.50	30.75	33.00	21.50
2	3.00	4.25	12.50	14.75	47.75	71.25	53.75	77.25	54.00	18.75	19.25	21.50
3	4.75	4.75	6.75	19.75	20.50	147.00	48.00	89.25	64.75	14.25	25.75	25.75
4	3.00	5.25	11.00	25.75	45.00	131.50	67.25	107.50	108.75	27.50	32.00	36.75
5	3.00	3.75	8.50	25.50	36.00	45.00	54.50	63.00	43.00	20.75	22.50	23.75
6	3.25	3.75	8.00	23.50	54.50	98.75	53.50	75.00	56.00	23.00	25.25	28.00
7	4.75	5.75	9.50	32.50	28.50	58.00	119.75	114.25	72.25	18.75	21.25	23.75
AVG	3.5	4.6	9.1	21.7	35.3	84.4	62.0	98.5	68.6	22.0	25.6	25.9
Max	4.75	5.75	12.50	32.50	54.50	147.00	119.75	163.00	108.75	30.75	33.00	36.75
Min	2.75	3.75	6.75	10.00	14.75	39.50	37.50	63.00	43.00	14.25	19.25	21.50

(Continued)

(Sheet 14 of 23)

Table 2 (Continued)

Wave No.	Shock Pressure, psi, at Indicated Elevation, ft											
	+22	+20	+18	+16	+14	+12	+10	+8	+6.5	+1.0	-1.5	-4.0
<u>swl = +8.6 ft; T = 6 sec; H = 12.5 ft</u>												
1	1.25	0.75	0.75	2.75	8.50	39.50	39.50	47.75	39.75	12.00	12.75	15.00
2	0.75	0.75	0.50	0.75	2.00	9.75	11.75	24.00	16.25	2.25	2.75	2.25
3	1.25	2.75	4.50	9.50	30.75	25.25	32.00	45.75	71.00	9.75	10.50	11.75
4	2.50	2.25	2.25	3.25	9.50	9.75	21.25	15.25	18.25	6.50	6.50	6.50
5	1.00	1.00	2.00	2.50	14.75	14.25	14.00	10.75	8.50	4.25	3.75	3.00
6	2.25	0.75	1.25	1.25	2.75	12.00	22.50	17.50	19.50	6.50	6.50	6.50
7	3.25	2.25	2.75	8.00	17.00	22.00	27.75	31.50	28.00	11.00	11.75	11.75
8	1.75	1.75	1.75	3.50	7.50	17.50	42.75	69.50	30.25	9.75	9.50	7.50
9	1.75	1.25	2.00	2.50	5.25	12.00	36.25	33.75	18.25	6.50	6.50	5.50
10	2.75	2.25	2.50	3.50	5.25	9.75	16.00	22.00	17.25	5.50	6.50	6.50
<u>swl = 8.6 ft; T = 8 sec; H = 14.1 ft</u>												
Avg	1.8	1.6	2.0	3.8	10.3	17.2	26.4	31.8	26.7	7.4	7.7	7.6
Max	3.25	2.75	4.50	9.50	30.75	39.50	42.75	69.50	71.00	12.00	12.75	15.00
Min	0.75	0.75	0.50	0.75	2.00	9.75	11.75	10.75	8.50	2.25	2.75	2.25
<u>swl = 8.6 ft; T = 8 sec; H = 14.1 ft</u>												
1	1.00	2.50	2.00	8.50	19.00	49.25	85.50	117.50	87.25	25.25	28.75	27.00
2	0.00	1.00	1.75	4.00	5.25	6.50	14.00	13.00	17.25	6.50	6.50	5.50
3	0.75	1.50	3.25	6.00	13.75	25.25	30.00	38.00	34.50	20.75	21.25	24.75
4	4.25	2.50	2.75	14.00	53.00	43.75	48.00	43.50	37.75	25.25	26.75	30.25
5	0.75	1.50	1.75	6.50	14.75	25.25	32.00	24.00	31.25	12.00	11.75	10.75
6	3.75	5.25	6.50	15.50	31.75	38.25	72.75	43.50	29.00	20.75	21.25	22.75
7	1.25	1.25	3.75	6.50	11.75	19.75	28.75	54.25	63.50	16.50	17.00	16.25
8	1.75	2.50	4.75	7.25	11.75	27.50	80.25	81.50	69.00	16.50	16.00	18.25

(Continued)

Table 2 (Continued)

Wave No.	Shock Pressure, psi, at Indicated Elevation, ft											
	+22	+20	+18	+16	+14	+12	+10	+8	+6.5	+1.0	-1.5	-4.0
<u>swl = 8.6 ft; T = 8 sec; H = 14.1 ft (Continued)</u>												
9	1.75	2.25	3.75	6.75	21.25	79.00	88.75	66.25	46.25	20.75	22.50	24.75
10	1.50	1.50	3.25	4.25	8.25	13.00	23.75	26.75	59.75	19.00	20.25	10.50
Avg	1.7	2.2	3.4	7.9	19.0	32.8	50.4	50.8	47.6	18.3	19.2	19.1
Max	4.25	5.25	6.50	15.50	53.00	49.25	85.50	117.50	87.25	25.25	28.75	30.25
Min	0.00	1.00	1.75	4.00	5.25	6.50	14.00	13.00	17.25	6.50	6.50	5.50
<u>swl = 8.6 ft; T = 10 sec; H = 12.1 ft</u>												
1	0.50	0.75	1.00	2.75	3.00	3.25	6.50	20.75	63.50	6.50	7.50	5.50
2	2.25	0.75	1.25	2.00	3.25	3.25	5.25	40.25	49.50	9.75	9.50	9.75
3	1.25	0.75	1.25	2.00	3.50	3.25	15.00	87.00	156.25	13.25	14.00	16.25
4	1.00	1.00	2.50	2.00	4.50	11.00	62.00	140.25	101.25	14.25	14.00	14.00
5	1.00	1.25	2.00	4.50	5.00	6.50	14.00	59.75	94.75	20.75	24.50	32.25
6	11.00	1.25	2.25	2.50	4.75	14.25	17.00	92.50	99.25	17.50	21.25	25.75
7	1.50	1.00	1.75	4.75	4.50	11.00	26.75	110.75	172.50	17.50	21.25	27.00
8	1.75	1.25	2.25	7.25	6.25	5.50	15.00	50.00	82.00	22.00	26.75	33.50
9	1.00	0.75	1.75	3.25	4.00	6.50	15.00	62.00	56.00	17.50	21.25	24.75
10	1.00	1.00	1.75	1.50	4.00	5.50	36.25	40.25	30.25	14.25	16.00	18.25
Avg	2.2	1.0	1.8	3.2	4.3	7.0	21.3	70.4	90.5	15.3	17.6	20.7
Max	11.00	1.25	2.50	7.25	6.25	14.25	62.00	140.25	156.25	22.00	26.75	33.50
Min	0.50	0.75	1.00	1.50	3.00	3.25	5.25	20.75	49.50	6.50	7.50	5.50

(Continued)

Table 2 (Continued)

Wave No.	Shock Pressure, psi, at Indicated Elevation, ft											
	+22	+20	+18	+16	+14	+12	+10	+8	+6.5	+1.5	-4.0	
<u>swl = 8.6 ft; T = 10 sec; H = 14.8 ft</u>												
1	0.50	1.25	0.75	5.25	2.25	14.25	17.00	92.50	11.75	26.25	32.00	38.75
2	10.75	1.25	0.75	1.50	2.25	6.50	11.75	25.00	44.25	11.00	10.75	10.75
3	1.50	1.50	1.00	1.50	3.50	8.75	11.75	32.50	38.75	14.25	17.00	18.25
4	3.75	2.00	1.25	1.50	3.50	7.75	28.75	59.75	118.50	25.25	28.75	32.25
5	1.25	4.50	6.75	10.75	10.50	6.50	43.75	154.25	59.25	23.00	26.75	31.25
6	1.00	1.75	2.25	3.50	3.50	7.75	18.25	39.25	43.00	16.50	18.25	19.50
7	2.00	3.75	4.25	9.50	32.75	11.00	19.25	68.50	125.00	22.00	23.50	28.00
8	1.75	1.00	2.50	4.00	3.75	12.00	28.75	58.75	75.50	23.00	26.75	31.25
9	4.50	1.00	2.25	2.00	3.50	6.50	18.25	40.25	29.00	14.25	16.00	16.25
10	2.00	1.00	2.00	2.50	3.50	9.75	16.00	27.25	24.75	9.75	11.75	10.75
<u>swl = 8.6 ft; T = 10 sec; H = 15.8 ft</u>												
Avg	2.9	1.9	2.4	4.2	6.6	9.1	21.4	59.8	57.0	18.5	21.2	23.7
Max	10.75	4.50	6.75	10.75	32.75	14.25	43.75	154.25	125.00	26.25	28.75	38.75
Min	0.50	1.00	0.75	1.50	2.25	6.50	11.75	25.00	11.75	11.00	10.75	10.75
<u>swl = 8.6 ft; T = 10 sec; H = 15.8 ft</u>												
1	0.75	2.00	9.00	34.00	16.00	12.00	19.25	65.25	89.50	27.50	31.00	38.75
2	2.25	2.00	0.75	5.25	5.25	11.00	19.25	42.50	74.25	14.25	15.00	15.00
3	9.25	2.25	3.00	6.00	6.25	11.00	27.75	53.25	41.00	16.50	18.25	21.50
4	2.00	2.25	5.50	6.50	6.25	11.00	12.75	41.25	55.00	15.25	15.00	19.50
5	3.75	1.50	2.50	4.00	5.25	11.00	16.00	43.50	64.75	17.50	18.25	20.50
6	1.75	1.75	2.50	4.50	5.25	9.75	24.50	43.50	59.25	24.00	26.75	33.50
7	3.50	2.25	1.25	4.00	6.25	12.00	22.50	49.00	73.25	26.25	28.75	35.50
8	3.50	1.00	1.75	4.00	6.25	13.25	26.75	39.25	84.00	27.50	30.00	35.50

(Continued)

Table 2 (Continued)

Wave No.	Shock Pressure, psi, at Indicated Elevation, ft											
	+22	+20	+18	+16	+14	+12	+10	+8	+6.5	+1.0	-1.5	-4.0
<u>swl = 8.6 ft; T = 10 sec; H = 15.8 ft (Continued)</u>												
9	14.25	1.00	1.25	3.25	5.25	9.75	26.75	54.25	101.25	33.00	37.50	47.50
10	2.25	1.00	1.25	3.25	5.25	9.75	11.75	70.75	135.75	12.00	15.00	16.25
Avg	4.3	1.7	2.9	7.5	6.7	11.0	20.7	50.2	77.8	21.4	23.6	28.4
Max	14.25	2.25	9.00	34.00	16.00	13.25	26.75	70.75	135.75	33.00	37.50	47.50
Min	0.75	1.00	0.75	3.25	5.25	9.75	11.75	39.25	41.00	12.00	15.00	15.00
<u>swl = 8.6 ft; T = 12 sec; H = 12.0 ft</u>												
1	0.50	0.75	1.75	1.50	3.25	4.50	6.50	39.25	64.75	9.75	11.75	15.00
2	0.00	1.00	1.75	2.75	3.25	13.25	70.50	106.50	71.00	14.25	16.00	13.00
3	0.25	0.75	1.75	2.50	2.00	12.00	32.00	32.50	29.00	9.75	10.75	13.00
4	1.50	0.75	1.75	2.75	2.00	12.00	27.75	31.50	29.00	7.75	7.50	8.50
5	1.00	0.75	1.75	6.00	3.25	18.75	44.75	19.50	15.00	7.75	8.50	7.50
6	1.00	1.00	3.75	3.50	2.00	16.50	42.75	49.00	32.25	8.75	9.50	10.75
7	1.50	1.00	1.75	2.50	2.00	17.50	21.25	15.25	11.75	8.75	8.50	9.75
8	1.00	1.00	1.75	4.75	2.00	12.00	18.25	15.25	13.00	7.75	7.50	7.50
9	1.00	1.00	3.50	1.50	2.00	29.50	72.75	24.00	18.25	8.75	8.50	10.75
Avg	0.9	0.9	2.2	3.1	2.4	15.1	37.4	37.0	31.6	9.2	9.8	10.6
Max	1.50	1.00	3.75	6.00	3.25	29.50	70.50	106.50	71.00	14.25	16.00	15.00
Min	0.00	0.75	1.75	1.50	2.00	4.50	6.50	15.25	11.75	7.75	7.50	7.50

(Continued)

Table 2 (Continued)

Wave No.	Shock Pressure, psi, at Indicated Elevation, ft											
	+22	+20	+18	+16	+14	+12	+10	+8	+6.5	+1.0	-1.5	-4.0
<u>swl = 8.6 ft; T = 12 sec; H = 14.0 ft</u>												
1	0.00	1.25	2.25	2.00	2.00	5.50	6.50	8.75	9.75	6.50	6.50	4.25
2	2.00	2.00	1.75	4.75	5.25	7.75	16.00	74.00	90.50	14.25	16.00	20.50
3	0.75	0.75	1.75	4.00	3.25	12.00	69.50	81.50	90.50	13.25	15.00	17.25
4	1.50	3.00	1.75	4.00	7.50	23.00	80.25	107.50	103.50	16.50	19.25	22.75
5	3.50	1.50	1.75	2.50	6.25	22.00	42.75	72.75	41.00	11.00	12.75	14.00
6	2.75	1.00	3.75	5.50	7.50	52.75	160.25	32.50	23.75	11.00	11.75	11.75
7	1.00	1.50	1.75	4.50	10.50	25.25	73.75	62.00	48.50	16.50	19.25	16.25
8	2.75	1.00	1.75	4.00	7.50	65.75	77.00	39.25	24.75	13.25	15.00	16.25
9	0.00	0.75	1.75	3.50	13.75	30.75	98.25	29.25	19.50	9.75	10.75	9.75
10	1.75	1.75	1.25	3.50	9.50	73.50	96.25	43.50	29.00	12.00	14.00	16.25
<u>swl = 8.6 ft; T = 12 sec; H = 16.8 ft</u>												
Avg	1.6	1.5	2.0	3.8	7.3	31.8	72.0	55.1	48.1	12.4	14.0	14.9
Max	3.50	3.00	3.75	4.75	13.75	73.50	160.25	107.50	103.50	16.50	19.25	22.75
Min	0.00	0.75	1.25	2.00	2.00	5.50	6.50	8.75	9.75	6.50	6.50	4.25
<u>swl = 8.6 ft; T = 12 sec; H = 16.8 ft</u>												
1	1.00	0.75	1.75	4.00	5.25	15.25	16.00	12.00	91.50	9.75	11.75	9.75
2	11.00	2.25	3.75	6.75	10.50	15.25	32.00	92.50	70.00	19.75	24.50	30.25
3	3.50	2.00	3.75	5.50	9.50	27.50	80.25	190.25	118.50	23.00	25.75	30.25
4	2.25	3.25	5.50	8.50	22.25	60.25	128.25	130.50	98.00	35.00	41.75	22.75
5	2.00	3.00	4.25	8.00	14.75	49.25	117.50	106.50	102.25	37.25	42.75	22.75
6	2.25	4.00	5.50	8.50	14.75	117.25	181.50	121.75	106.75	26.25	30.00	35.50
7	2.25	4.25	5.50	18.00	28.50	46.00	79.00	49.00	49.50	23.00	25.75	27.00
8	4.50	3.50	5.25	8.50	16.00	71.25	122.75	95.75	74.25	26.25	27.75	34.50

(Continued)

(Sheet 19 of 23)

Table 2 (Continued)

Wave No.	Shock Pressure, psi, at Indicated Elevation, ft											
	+22	+20	+18	+16	+14	+12	+10	+8	+6.5	+1.0	-1.5	-4.0
<u>swl = 8.6 ft; T = 12 sec; H = 16.8 ft (Continued)</u>												
9	2.75	3.25	4.25	10.75	22.25	46.00	129.00	147.75	108.00	35.00	42.75	43.00
10	2.75	4.25	6.50	10.00	27.50	93.25	122.75	103.25	70.00	21.75	25.75	32.25
Avg	3.4	2.8	4.6	8.8	17.1	54.1	100.9	104.9	88.9	25.7	29.8	28.8
Max	11.0	4.25	6.50	18.00	28.50	117.25	181.50	190.25	118.50	37.25	42.75	43.00
Min	1.00	0.75	1.75	4.00	5.25	15.25	16.00	12.00	49.50	9.75	11.75	9.75
<u>swl = 8.6 ft; T = 12 sec; H = 16.0 ft</u>												
1	2.25	2.25	2.50	8.00	16.00	18.75	19.25	35.75	47.75	14.25	15.00	15.00
2	3.25	3.75	6.00	14.00	23.25	25.25	110.00	66.25	185.75	42.75	49.25	32.25
3	2.00	4.00	6.50	11.25	22.25	50.50	139.00	119.50	113.00	46.00	54.50	32.25
4	1.50	4.75	8.50	38.50	46.75	109.75	68.50	66.25	57.50	45.00	50.25	21.50
5	2.25	6.25	6.00	18.75	38.25	94.25	85.50	51.00	44.50	29.50	32.00	35.50
6	12.00	8.50	23.50	52.00	46.75	120.50	68.50	49.00	43.50	27.50	39.50	21.25
7	3.75	8.50	6.25	13.75	38.00	65.75	34.75	85.75	79.25	35.00	37.50	28.50
8	4.50	8.50	6.25	24.00	53.25	109.75	41.25	53.25	49.00	29.50	36.25	**
9	3.25	8.50	19.75	37.75	**	104.25	**	49.00	45.75	36.25	42.75	**
10	4.50	9.00	15.50	61.50	**	131.00	**	59.75	54.25	27.50	30.00	**
Avg	3.8	6.4	10.1	28.0	35.6	83.0	70.8	63.6	72.0	33.3	38.7	23.3
Max	12.00	9.00	23.50	61.50	53.25	120.50	139.00	119.50	185.75	46.00	54.50	35.50
Min	1.50	2.25	2.50	8.00	16.00	18.75	19.25	35.75	43.50	14.25	15.00	15.00

(Continued)

** No record.

Table 2 (Continued)

Wave No.	Shock Pressure, psi, at Indicated Elevation, ft											
	+22	+20	+18	+16	+14	+12	+10	+8	+6.5	+1.0	-1.5	-4.0
	<u>swl = 8.6 ft; T = 14 sec; H = 12.0 ft</u>											
1	1.00	1.00	2.25	2.75	5.25	8.75	20.25	28.25	71.00	12.00	14.00	16.25
2	3.00	1.25	3.00	4.50	5.25	7.75	14.00	12.00	11.75	5.50	7.50	6.50
3	10.25	1.75	3.25	3.50	5.25	7.75	8.50	19.50	22.75	7.75	7.50	7.50
4	1.75	1.75	3.75	3.50	4.25	5.50	20.25	44.50	29.00	6.50	7.50	8.50
5	5.50	1.75	4.25	3.25	4.25	5.50	5.25	7.50	8.50	7.75	7.50	6.50
6	5.00	2.25	2.50	4.00	4.25	5.50	12.75	16.25	13.00	5.50	7.50	6.50
7	2.00	1.75	2.50	4.00	5.25	13.25	20.25	15.25	15.00	7.75	9.50	9.75
8	1.00	1.00	2.50	3.25	5.25	7.75	10.75	59.75	23.50	8.75	10.75	13.00
9	1.00	1.00	2.25	4.00	5.25	9.75	20.25	17.50	21.50	9.75	10.75	10.75
Avg	3.4	1.5	2.9	3.6	4.9	7.9	14.7	24.5	24.0	7.9	9.2	9.5
Max	10.25	2.25	4.25	4.50	5.25	13.25	20.25	59.75	71.00	12.00	14.00	16.25
Min	1.00	1.00	2.25	2.75	4.25	5.50	8.50	7.50	8.50	5.50	7.50	6.50
	<u>swl = 8.6 ft; T = 14 sec; H = 14.0 ft</u>											
1	1.25	1.50	2.25	4.00	5.25	11.00	53.50	74.00	71.00	17.50	22.50	30.25
2	1.00	2.25	3.50	5.50	9.50	14.25	24.50	34.75	29.00	9.75	12.75	17.25
3	1.00	3.00	4.75	6.00	8.50	9.75	10.75	10.75	10.75	8.75	9.50	10.75
4	1.00	2.25	3.50	4.75	7.50	12.00	28.75	19.50	14.00	8.75	9.50	10.75
5	1.50	2.50	5.25	6.50	8.50	15.25	15.00	13.00	11.75	8.75	9.50	10.75
6	1.75	3.00	4.25	6.00	8.50	8.75	9.50	12.00	11.75	8.75	9.50	10.75
7	1.75	2.25	4.25	5.50	8.50	8.75	10.75	10.75	10.75	8.75	10.75	10.75

(Continued)

Table 2 (Continued)

Wave No.	Shock Pressure, psi, at Indicated Elevation, ft											
	+22	+20	+18	+16	+14	+12	+10	+8	+6.5	+1.0	-1.5	-4.0
<u>swl = 8.6 ft; T = 14 sec; H = 14.0 ft (Continued)</u>												
8	1.00	2.75	4.25	6.00	7.50	8.75	11.75	12.00	11.75	9.75	10.75	11.75
9	1.00	2.50	3.75	5.50	8.50	9.75	9.50	12.00	10.75	8.75	10.75	10.75
Avg	1.2	2.4	4.0	5.5	8.0	10.9	19.3	22.1	20.2	9.9	11.7	13.8
Max	1.75	3.00	5.25	6.50	9.50	15.25	53.50	74.00	71.00	17.50	22.50	30.25
Min	1.00	1.50	2.25	4.00	5.25	8.75	9.50	10.75	10.75	8.75	9.50	10.75
<u>swl = 8.6 ft; T = 14 sec; H = 17.0 ft</u>												
1	1.00	3.25	4.75	8.00	16.00	22.00	21.25	49.00	34.50	12.00	12.75	16.25
2	2.75	4.25	6.50	8.00	10.50	11.00	10.75	10.75	11.75	11.00	9.50	10.75
3	4.50	4.00	6.50	9.25	10.50	12.00	12.75	14.25	14.00	11.00	10.75	11.75
4	4.50	6.75	9.50	12.00	12.75	14.25	13.75	13.00	13.00	12.00	10.75	12.75
5	2.25	4.25	6.00	8.25	9.50	11.00	11.75	12.00	13.00	12.00	10.75	12.75
6	4.50	5.25	7.25	9.50	10.50	13.25	12.75	13.00	13.00	11.00	10.75	11.75
7	2.75	4.25	6.50	8.00	10.50	9.75	10.75	12.00	11.75	9.75	9.50	11.75
8	2.75	4.25	6.75	9.25	10.50	13.25	14.00	16.25	15.00	12.00	11.75	12.75
Avg	3.1	4.5	6.7	9.0	11.3	13.3	13.5	17.5	15.8	11.3	10.8	12.6
Max	4.50	6.75	9.50	12.00	16.00	22.00	21.25	49.00	34.50	12.00	12.75	16.25
Min	1.00	3.25	4.75	8.00	9.50	9.75	10.75	10.75	11.75	9.75	9.50	10.75

(Continued)

Table 2 (Concluded)

Wave No.	Shock Pressure, psi, at Indicated Elevation, ft											
	+22	+20	+18	+16	+14	+12	+10	+8	+6.5	+1.0	-1.5	-4.0
1	6.50	12.50	14.50	22.00	24.75	53.75	50.00	81.50	41.00	17.50	17.00	21.50
2	8.00	13.25	24.25	29.00	24.25	22.00	20.25	30.50	19.50	16.50	16.00	16.25
3	10.00	12.00	12.75	14.00	16.00	15.25	16.00	27.25	16.25	13.25	12.75	13.00
4	9.00	18.00	21.25	22.25	42.25	52.75	53.75	54.25	29.00	20.75	20.25	20.50
5	10.00	12.00	52.25	32.00	38.25	27.50	22.25	32.50	19.50	15.25	15.00	16.25
6	5.50	7.50	16.25	20.00	42.50	27.50	22.50	33.75	18.25	11.00	11.75	13.00
7	7.75	8.75	34.25	31.75	27.50	24.00	21.25	29.25	21.50	16.50	16.00	16.25
8	8.50	8.75	27.75	61.50	27.50	27.50	22.50	28.25	23.75	17.50	18.25	18.25
AVG	8.2	11.6	25.4	29.1	30.4	31.3	28.6	39.7	23.6	16.0	15.9	16.9
Max	10.00	18.00	52.25	61.50	42.50	53.75	53.75	81.50	41.00	20.75	20.25	21.50
Min	6.50	7.50	12.75	14.00	16.00	15.25	16.00	27.25	16.25	11.00	11.75	13.00

swl = 8.6 ft; T = 14 sec; H = 11.4 ft

Table 3

Average Secondary Pressures on Vertical Seawall, Plan R4S1

swl ft	Incident Wave		Wave Form	Average Pressure, psi, for Indicated Elevation, ft											
	T, sec	H, ft		+22.0	+20.0	+18.0	+16.0	+14.0	+12.0	+10.0	+8.0	+6.5	+1.0	-1.5	-4.0
+2.6	6.0	9.0	Breaking	*	*	*	*	*	*	*	*	*	*	*	*
	8.0	11.1	Breaking	*	*	*	*	*	*	*	*	*	*	*	*
	10.0	11.0	Breaking	*	*	*	*	*	*	*	*	*	*	*	*
	12.0	12.6	Breaking	*	*	*	*	*	*	*	*	*	*	*	*
	14.0	12.7	Breaking	*	*	*	*	*	*	*	*	*	*	*	*
+4.3	6.0	11.5	Breaking	*	*	*	*	*	*	*	*	*	*	*	*
	8.0	13.1	Breaking	0.3	0.3	0.3	0.3	0.4	0.4	1.4	2.1	2.6	3.3	3.3	2.9
	10.0	12.8	Breaking	0.3	0.3	0.4	0.3	1.0	1.0	1.9	2.8	3.3	3.9	3.9	3.3
	12.0	12.7	Breaking	0.4	0.3	0.5	0.3	1.0	1.0	2.0	2.7	3.1	3.7	3.8	3.4
	14.0	13.1	Breaking	0.9	0.3	0.7	0.5	1.5	1.7	2.4	3.4	3.8	4.3	4.7	4.4
+6.9	6.0	10.7	Breaking	0.4	0.4	0.4	0.3	0.7	0.8	1.3	2.1	2.6	2.0	1.8	1.5
	8.0	13.4	Breaking	0.4	0.3	0.6	0.5	1.2	1.7	2.3	3.1	3.2	2.9	3.0	3.7
	10.0	14.0	Nonbreaking	0.7	0.4	0.6	1.0	1.8	2.5	3.1	3.9	4.4	3.6	3.9	3.3
	10.0	14.7	Nonbreaking	0.4	0.5	1.0	1.0	1.8	2.1	3.0	4.1	4.3	3.7	3.7	3.4
	10.0	15.7	Breaking	0.7	0.7	1.3	1.5	2.2	2.8	3.4	4.5	4.7	4.5	4.4	4.2
	12.0	12.0	Nonbreaking	0.3	0.5	1.0	1.2	2.2	2.6	3.5	4.5	4.7	4.3	4.5	4.0
	12.0	14.0	Nonbreaking	0.9	0.8	1.2	1.4	2.4	2.8	3.8	4.5	5.2	4.5	4.9	4.5
	12.0	16.0	Breaking	0.9	0.6	1.3	1.5	2.6	2.9	3.8	4.5	4.8	4.5	4.8	4.3
	12.0	13.3	Prebreaking	0.8	0.5	1.0	1.1	2.5	2.8	3.5	4.5	5.0	4.4	4.6	4.1
	14.0	12.0	Nonbreaking	0.6	0.7	1.5	1.7	2.7	2.9	4.0	4.8	5.4	4.9	5.1	4.7
	14.0	14.0	Nonbreaking	0.6	0.8	1.5	1.7	2.8	3.2	4.0	4.9	5.7	4.9	5.2	4.7
	14.0	16.3	Breaking	0.8	0.8	1.6	1.8	2.8	3.2	4.1	5.2	5.5	5.2	5.3	4.7
	14.0	11.2	Prebreaking	1.0	1.1	1.5	1.8	2.8	3.0	4.0	4.9	5.2	5.0	5.0	4.7

(Continued)

* Negligible.

Table 3 (Concluded)

swl ft	Incident Wave		Wave Form	Average Pressure, psi, for Indicated Elevation, ft											
	T, sec	H, ft		+22.0	+20.0	+18.0	+16.0	+14.0	+12.0	+10.0	+8.0	+6.5	+1.0	-1.5	-4.0
+8.6	6.0	12.5	Breaking	0.6	0.3	0.4	0.3	0.9	1.3	1.7	3.0	2.2	2.1	2.2	1.5
	8.0	14.1	Breaking	0.4	0.4	0.9	0.8	1.6	2.3	2.8	3.9	3.5	3.2	3.1	2.4
	10.0	12.1	Nonbreaking	0.8	0.9	1.5	1.8	2.6	3.1	3.7	4.3	4.2	4.3	4.5	3.8
	10.0	14.8	Nonbreaking	0.6	1.1	1.1	1.4	1.3	2.8	3.4	4.3	3.0	4.0	4.0	2.0
	10.0	15.8	Breaking	0.9	0.9	1.7	2.0	2.8	3.4	3.8	4.7	4.4	4.0	3.9	3.6
	12.0	12.0	Nonbreaking	0.4	1.0	1.8	2.1	3.0	3.3	4.2	5.2	4.4	4.3	4.3	3.6
	12.0	14.0	Nonbreaking	0.9	0.9	1.6	1.9	2.5	3.2	3.8	4.6	4.3	4.2	4.4	3.9
	12.0	16.8	Breaking	1.0	0.9	1.8	1.9	2.4	3.4	3.8	4.7	3.9	5.0	5.1	3.6
	12.0	16.0	Prebreaking	1.1	1.1	1.8	2.1	2.5	3.6	3.9	4.7	4.3	5.0	5.1	3.7
	14.0	12.0	Nonbreaking	1.5	1.2	2.7	2.6	3.9	4.2	5.0	5.6	5.5	4.7	4.9	4.4
	14.0	14.0	Nonbreaking	1.0	1.1	2.2	2.6	3.5	3.9	4.6	5.5	5.3	4.6	5.1	4.5
	14.0	17.0	Breaking	1.5	1.4	3.1	3.2	4.4	4.6	5.4	5.6	5.6	4.7	4.9	4.8
	14.0	11.4	Prebreaking	1.6	1.3	2.6	2.6	4.0	4.1	5.0	5.7	5.4	4.7	4.7	4.4

Table 4

Shock Pressure Data, Test Series 1, Plan R4S2

Wave No.	Shock Pressure, psi, at Indicated Elevation, ft										
	+22	+20	+18	+16	+14	+12	+10	+8	+1.0	-1.5	-4.0
1	*	*	*	*	*	*	*	*	2.25	2.50	3.50
2	*	*	*	*	*	*	*	*	2.25	2.25	3.00
3	*	*	*	*	*	*	*	*	2.00	2.00	2.00
4	*	*	*	*	*	*	*	*	2.50	2.50	3.00
5	*	*	*	*	*	*	*	*	2.50	2.50	2.75
6	*	*	*	*	*	*	*	*	2.25	2.25	2.50
7	*	*	*	*	*	*	*	*	2.50	2.50	2.75
8	*	*	*	*	*	*	*	*	2.25	2.25	2.50
9	*	*	*	*	*	*	*	*	2.50	2.50	2.50
10	*	*	*	*	*	*	*	*	2.25	2.50	3.50
Avg									2.3	2.4	2.8
Max									2.50	2.50	3.50
Min									2.00	2.00	2.00

swl = 2.6 ft; T = 6 sec; H = 9.0 ft											
1	*	*	*	*	*	*	*	*	2.75	4.25	6.25
2	*	*	*	*	*	*	*	*	3.00	4.00	8.25
3	*	*	*	*	*	*	*	*	4.50	4.75	5.50
4	*	*	*	*	*	*	*	*	3.75	5.25	6.00
5	*	*	*	*	*	*	*	*	4.25	4.50	6.50
6	*	*	*	*	*	*	*	3.00	4.00	4.50	

swl = 2.6 ft; T = 8 sec; H = 11.1 ft											
1	*	*	*	*	*	*	*	*	3.75	4.25	6.25
2	*	*	*	*	*	*	*	*	3.00	4.00	8.25
3	*	*	*	*	*	*	*	*	4.50	4.75	5.50
4	*	*	*	*	*	*	*	*	3.75	5.25	6.00
5	*	*	*	*	*	*	*	*	4.25	4.50	6.50
6	*	*	*	*	*	*	*	3.00	4.00	4.50	

* Negligible.

Table 4 (Continued)

Wave No.	Shock Pressure, psi, at Indicated Elevation, ft										
	+22	+20	+18	+16	+14	+12	+10	+8	+1.0	-1.5	-4.0
<u>swl = 2.6 ft; T = 8 sec; H = 11.1 ft (Continued)</u>											
7	*	*	*	*	*	*	*	4.25	4.25	5.75	8.50
8	*	*	*	*	*	*	*	2.00	4.25	5.00	6.50
9	*	*	*	*	*	*	*	1.75	4.25	4.75	6.25
Avg								4.25	4.50	5.75	8.50
Max								1.75	3.00	4.00	4.50
Min											
<u>swl = 2.6 ft; T = 10 sec; H = 11.0 ft</u>											
1	*	*	*	0.00	1.00	**	**	1.00	2.25	5.25	10.50
2	*	*	*	1.50	0.00	**	**	3.00	2.25	5.00	10.50
3	*	*	*	1.25	1.50	**	**	0.00	2.25	4.75	6.00
4	*	*	*	1.50	1.50	**	**	0.50	2.50	4.75	5.50
5	*	*	*	1.50	2.00	**	**	0.50	2.25	4.00	10.00
6	*	*	*	2.00	1.25	**	**	1.50	2.00	5.00	10.25
7	*	*	*	2.50	1.75	**	**	1.00	2.75	5.00	10.00
Avg				1.5	1.3			1.1	2.3	4.4	9.0
Max				2.50	2.00			3.00	2.75	5.25	10.50
Min				0.00	0.00			0.00	2.00	4.00	5.50

* Negligible.
** No record.

Table 4 (Continued)

Wave No.	Shock Pressure, psi, at Indicated Elevation, ft										
	+22	+20	+18	+16	+14	+12	+10	+8	+1.0	-1.5	-4.0
<u>swl = 2.6 ft; T = 12 sec; H = 12.6 ft</u>											
1	0.50	1.50	2.75	4.50	2.75	**	0.25	2.75	6.00	10.00	27.50
2	0.50	1.75	2.75	3.50	2.75	**	2.00	2.75	4.50	5.25	13.25
3	0.25	1.75	3.75	4.25	3.25	**	3.50	3.50	4.75	5.00	6.25
4	0.75	1.25	2.75	3.50	2.25	**	0.25	3.00	5.00	8.50	30.50
5	0.25	3.00	2.50	3.75	2.00	**	2.00	2.75	5.00	5.75	12.75
6	0.25	3.00	2.75	3.75	2.50	**	0.25	3.00	5.00	5.25	7.75
<u>swl = 2.6 ft; T = 14 sec; H = 12.7 ft</u>											
AVG	0.4	2.0	2.9	3.9	2.6		1.4	3.0	5.0	6.6	16.3
Max	0.75	3.00	3.75	4.50	3.25		3.50	3.50	6.00	10.00	30.50
Min	0.25	1.25	2.50	3.50	2.00		0.25	2.75	4.50	5.00	6.25
1	0.00	1.50	2.75	4.00	2.50	1.50	*	3.00	5.75	7.50	13.25
2	0.25	1.50	2.75	3.50	2.75	1.00	*	3.25	5.75	9.00	12.00
3	0.25	0.00	2.75	3.25	4.00	1.00	*	3.25	6.50	9.00	27.25
4	0.25	1.50	2.25	3.50	2.50	1.00	*	2.75	5.50	6.75	9.25
5	0.00	1.50	3.25	3.00	2.25	1.50	*	2.75	5.00	5.75	11.00
6	0.25	2.00	2.75	4.25	2.25	1.00	*	2.75	8.50	8.00	10.00
AVG	0.2	1.3	2.8	3.6	2.7	1.2		3.0	6.2	7.7	13.9
Max	0.25	2.00	3.25	4.25	4.00	1.50		3.25	8.50	9.00	27.25
Min	0.00	0.00	2.25	3.00	2.25	1.00		2.75	5.00	5.75	9.25

* Negligible.

** No record.

Table 4 (Continued)

Wave No.	Shock Pressure, psi, at Indicated Elevation, ft										
	+22	+20	+18	+16	+14	+12	+10	+8	+1.0	-1.5	-4.0
1	*	*	*	*	*	*	*	1.50	1.50	1.75	1.75
2	*	*	*	*	*	*	*	1.25	1.50	1.75	1.50
3	*	*	*	*	*	*	*	1.50	1.75	2.00	2.25
4	*	*	*	*	*	*	*	2.50	3.00	3.75	2.75
5	*	*	*	*	*	*	*	1.50	1.50	1.75	1.75
6	*	*	*	*	*	*	*	3.25	3.25	4.75	4.00
7	*	*	*	*	*	*	*	3.00	2.75	3.25	3.50
8	*	*	*	*	*	*	*	3.25	2.00	2.25	3.25
9	*	*	*	*	*	*	*	2.75	3.00	3.50	4.25
10	*	*	*	*	*	*	*	3.25	2.00	2.50	2.75
Avg								2.4	2.2	2.7	2.8
Max								3.25	3.25	4.75	4.25
Min								1.25	1.50	1.75	1.50

<u>swl = 4.3 ft; T = 6 sec; H = 11.5 ft</u>											
1	*	*	*	*	*	*	*	*	*	*	*
2	*	*	*	*	*	*	*	*	*	*	*
3	*	*	*	*	*	*	*	*	*	*	*
4	*	*	*	*	*	*	*	*	*	*	*
5	*	*	*	*	*	*	*	*	*	*	*
6	*	*	*	*	*	*	*	*	*	*	*
7	*	*	*	*	*	*	*	*	*	*	*
8	*	*	*	*	*	*	*	*	*	*	*
9	*	*	*	*	*	*	*	*	*	*	*
10	*	*	*	*	*	*	*	*	*	*	*

<u>swl = 4.3 ft; T = 8 sec; H = 13.1 ft</u>											
1	*	3.50	1.75	2.50	4.25	4.25	4.25	4.25	6.25	6.50	9.50
2	*	0.75	0.75	1.75	2.25	2.25	1.75	1.75	2.00	2.25	2.50
3	*	0.50	0.50	0.25	0.50	0.50	0.50	0.50	2.50	2.50	2.75
4	*	1.00	0.75	1.75	1.50	1.50	1.75	1.75	2.25	2.75	3.50
5	*	1.00	1.25	0.75	1.00	1.00	2.75	2.75	2.25	2.75	4.75
6	*	1.00	1.00	1.00	1.25	1.25	2.50	2.50	2.50	2.75	4.50
7	*	5.00	1.75	1.50	1.50	1.50	4.75	4.75	5.50	8.25	10.00
8	*	2.00	2.25	1.50	1.50	1.50	3.00	3.00	2.75	3.25	4.75

* Negligible.

Table 4 (Continued)

Wave No.	Shock Pressure, psi, at Indicated Elevation, ft										
	+22	+20	+18	+16	+14	+12	+10	+8	+1.0	-1.5	-4.0
9	*	*	*	1.00	0.50	0.50	1.50	2.75	2.75	3.00	4.25
10	*	*	*	1.00	1.25	1.00	1.25	3.25	2.50	3.00	3.00
Avg				1.7	1.2	1.2	1.6	3.0	3.1	3.7	5.0
Max				5.00	2.25	2.50	4.25	4.75	6.25	8.25	10.00
Min				0.50	0.50	0.25	0.50	1.75	2.00	2.25	2.50
<u>swl = 4.3 ft; T = 8 sec; H = 13.1 ft (Continued)</u>											
<u>swl = 4.3 ft; T = 10 sec; H = 12.8 ft</u>											
1	0.50	2.50	3.75	4.25	2.75	1.75	2.00	4.25	7.00	9.50	15.50
2	0.25	2.25	4.00	4.00	3.25	2.75	2.75	3.75	5.00	6.25	9.00
3	0.50	2.50	3.50	4.00	3.00	1.75	2.25	3.25	4.50	4.75	9.00
4	1.00	1.75	3.25	3.75	2.75	1.75	2.00	3.75	5.00	5.25	5.75
5	0.50	3.00	4.25	4.25	3.50	1.75	2.00	4.00	4.50	5.00	5.75
6	1.00	2.25	4.00	4.50	5.00	1.75	1.50	3.75	4.50	4.75	6.25
7	0.50	3.25	6.25	5.75	3.00	2.00	2.50	3.75	5.50	6.25	8.00
Avg	0.6	2.5	4.1	4.4	3.3	1.9	2.1	3.8	5.1	6.0	8.5
Max	1.00	3.25	6.25	5.75	5.00	2.75	2.75	4.25	7.00	9.50	15.50
Min	0.25	1.75	3.25	3.75	2.75	1.75	1.50	3.25	4.50	4.75	5.75

* Negligible.

Table 4 (Continued)

Wave No.	Shock Pressure, psi, at Indicated Elevation, ft										
	+22	+20	+18	+16	+14	+12	+10	+8	+1.0	-1.5	-4.0
<u>swl = 4.3 ft; T = 12 sec; H = 12.7 ft</u>											
1	1.00	3.25	4.25	5.00	4.00	2.00	2.50	5.00	6.25	8.00	15.00
2	2.25	5.25	7.00	7.75	4.25	2.00	2.50	4.75	6.00	7.00	14.50
3	1.00	5.50	6.75	9.75	4.50	2.50	4.75	6.50	5.75	8.00	23.25
4	3.50	4.25	4.75	10.25	5.00	2.50	3.75	6.00	6.25	7.00	9.00
5	0.25	4.00	5.00	5.75	4.00	4.50	3.75	5.00	8.00	10.00	11.50
6	1.25	4.50	5.50	6.75	4.25	2.25	2.50	5.00	6.00	7.25	12.25
7	0.25	4.25	4.75	5.75	4.00	2.00	2.50	6.00	8.25	12.00	14.00
<u>swl = 4.3 ft; T = 14 sec; H = 13.1 ft</u>											
AVG	1.4	4.4	5.4	7.3	4.3	2.5	3.2	5.5	6.6	8.5	14.2
Max	3.50	5.50	7.00	10.25	5.00	4.50	4.75	6.50	8.25	12.00	23.25
Min	0.25	3.25	4.25	5.00	4.00	2.00	2.50	4.75	5.75	7.00	9.00
<u>swl = 4.3 ft; T = 14 sec; H = 13.1 ft</u>											
1	0.25	3.25	4.50	5.50	3.75	2.75	2.50	4.25	6.00	6.75	8.75
2	0.25	4.00	6.00	6.75	3.50	2.50	3.25	4.75	5.50	6.00	6.00
3	0.25	2.50	3.50	6.25	3.25	2.75	1.75	3.00	4.00	4.75	4.50
4	1.00	7.75	8.25	9.50	5.00	4.25	4.00	7.00	9.00	11.00	13.50
5	0.50	5.75	7.00	6.75	5.00	3.25	3.75	7.00	7.25	8.50	10.00
6	0.25	5.50	6.50	9.75	6.25	4.50	4.50	6.00	6.50	8.00	8.50
7	0.25	4.50	5.75	6.50	4.75	3.25	3.25	5.00	5.00	8.25	9.50
<u>swl = 4.3 ft; T = 14 sec; H = 13.1 ft</u>											
AVG	0.4	4.8	5.9	7.3	4.5	3.3	3.3	5.3	6.2	7.6	8.7
Max	1.00	7.75	8.25	9.50	6.25	4.50	4.50	7.00	9.00	11.00	13.50
Min	0.25	2.50	3.50	5.50	3.25	2.75	1.75	3.00	4.00	4.75	4.50

(Continued)

(Sheet 6 of 23)

Table 4 (Continued)

Wave No.	Shock Pressure, psi, at Indicated Elevation, ft										
	+22	+20	+18	+16	+14	+12	+10	+8	+1.0	-1.5	-4.0
<u>swl = 6.9 ft; T = 6 sec; H = 10.7 ft</u>											
1	0.50	3.00	3.50	5.00	3.75	3.25	2.50	5.75	4.00	4.25	5.50
2	0.50	1.50	1.00	2.75	1.75	2.00	3.00	4.00	2.00	2.75	3.25
3	0.75	1.00	3.25	4.00	2.25	3.50	2.75	10.50	2.50	3.25	5.00
4	0.50	4.00	2.25	6.00	2.75	2.00	2.75	4.50	3.00	3.25	4.50
5	0.50	0.75	3.00	3.25	2.25	3.00	6.00	5.75	2.25	2.50	2.00
6	0.75	3.75	2.50	3.25	3.00	2.00	2.25	5.00	3.00	3.25	3.50
7	0.50	1.00	1.50	2.00	2.50	1.75	7.00	6.50	2.00	2.00	2.00
8	0.75	1.00	1.50	2.50	2.50	2.50	2.50	4.25	3.00	3.25	3.25
9	0.50	3.00	3.00	4.25	3.75	2.25	2.00	3.25	2.75	3.00	3.50
10	0.75	3.00	3.00	5.00	4.00	2.25	2.25	4.25	5.00	6.25	9.00
<u>swl = 6.9 ft; T = 8 sec; H = 13.4 ft</u>											
Avg	0.6	2.2	2.4	3.8	2.8	2.4	3.3	5.4	3.0	3.4	4.2
Max	0.75	4.00	3.50	6.00	4.00	3.50	7.00	10.50	5.00	6.25	9.00
Min	0.50	0.75	1.00	2.00	1.75	1.75	2.00	3.25	2.00	2.00	2.00

swl = 6.9 ft; T = 8 sec; H = 13.4 ft

1	1.00	3.75	3.00	7.00	5.00	2.50	3.50	7.00	5.00	6.25	7.00
2	0.25	3.00	4.25	5.00	4.00	3.00	2.75	6.00	7.00	8.25	9.00
3	0.25	3.00	3.75	5.00	4.75	2.00	2.50	4.75	7.25	7.25	11.00
4	0.50	2.75	4.25	5.00	4.00	3.25	2.75	4.00	6.00	8.00	10.00
5	1.25	2.00	3.25	3.50	3.25	2.75	3.25	4.25	4.50	5.00	6.00
6	0.50	2.50	3.00	3.75	4.50	3.00	3.00	4.25	5.25	6.00	7.25
7	0.50	2.00	2.50	3.75	2.75	2.75	6.25	5.75	5.00	5.50	6.00

(Continued)

Table 4 (Continued)

Wave No.	Shock Pressure, psi, at Indicated Elevation, ft										
	+22	+20	+18	+16	+14	+12	+10	+8	+1.0	-1.5	-4.0
<u>swl = 6.9 ft; T = 8 sec; H = 13.4 ft (Continued)</u>											
8	0.50	3.00	4.00	4.75	4.00	3.75	2.50	4.00	6.00	7.25	7.75
9	0.25	2.50	3.00	3.75	3.25	3.25	2.50	4.50	8.25	10.00	12.75
Avg	0.6	2.7	3.4	4.6	3.9	2.9	3.2	4.9	6.0	7.1	8.5
Max	1.25	3.75	4.25	7.00	5.00	3.75	6.25	7.00	8.25	10.00	12.75
Min	0.25	2.00	2.50	3.50	2.75	2.00	2.50	4.00	4.50	5.00	6.00
<u>swl = 6.9 ft; T = 10 sec; H = 14.7 ft</u>											
1	0.50	3.00	4.50	4.75	5.00	3.75	3.75	5.50	4.25	3.75	5.25
2	1.50	4.50	6.25	5.75	5.75	5.75	4.50	6.00	5.00	5.25	7.25
3	0.50	2.25	3.50	4.00	4.25	3.75	4.00	5.50	3.75	3.50	3.25
4	0.25	3.00	4.00	4.25	4.25	3.75	3.75	5.00	4.00	4.25	5.50
5	0.50	2.75	4.50	4.25	4.25	4.00	3.75	5.25	4.00	4.25	6.00
6	0.50	3.00	4.50	4.50	5.00	3.75	3.75	5.00	4.25	4.00	5.25
7	0.25	2.25	3.00	3.00	4.00	3.50	3.50	4.75	4.00	4.00	5.00
8	0.25	2.25	3.25	3.50	4.00	3.75	3.75	4.75	3.75	3.50	3.50
Avg	0.5	2.9	4.2	4.2	4.6	4.0	3.8	5.2	4.1	4.1	5.1
Max	1.50	4.50	6.25	5.75	5.75	5.75	4.50	6.00	5.00	5.25	7.25
Min	0.25	2.25	3.00	3.00	4.00	3.50	3.50	4.75	3.75	3.50	3.25

(Continued)

(Sheet 8 of 23)

Table 4 (Continued)

Wave No.	Shock Pressure, psi, at Indicated Elevation, ft										
	+22	+20	+18	+16	+14	+12	+10	+8	+1.0	-1.5	-4.0
<u>swl = 6.9 ft; T = 10 sec; H = 15.7 ft</u>											
1	0.50	5.00	6.00	6.50	4.75	3.50	3.50	5.50	4.75	5.25	8.25
2	0.50	6.75	8.25	8.00	7.75	6.00	5.75	6.50	7.50	8.25	10.50
3	0.50	4.25	6.00	6.00	5.25	4.25	4.00	6.00	3.75	4.25	3.75
4	0.75	4.25	6.50	6.50	6.50	5.00	4.75	5.50	4.00	4.50	4.25
5	0.75	3.25	4.50	5.00	5.75	4.75	4.75	6.00	4.00	4.25	6.00
6	0.50	3.00	4.75	5.00	5.00	4.50	4.50	6.00	5.00	5.25	5.50
7	0.75	3.25	4.75	4.75	5.00	5.00	4.75	6.00	3.75	4.75	7.25
8	0.75	4.00	5.25	5.25	5.75	5.00	4.75	6.00	4.00	4.00	4.50
9	1.25	4.50	6.25	6.25	6.00	5.25	5.00	6.00	4.00	4.25	4.75
<u>swl = 6.9 ft; T = 10 sec; H = 14.0 ft</u>											
Avg	0.7	4.2	5.8	5.9	5.8	4.8	4.6	5.9	4.5	5.0	6.1
Max	1.25	6.75	8.25	8.00	7.75	6.00	5.75	6.50	7.50	8.25	10.50
Min	0.50	3.00	4.50	4.75	4.75	3.50	3.50	5.50	3.75	4.00	3.75
<u>swl = 6.9 ft; T = 10 sec; H = 14.0 ft</u>											
1	1.00	2.00	3.00	3.25	4.75	3.00	3.00	4.25	3.00	3.50	3.50
2	0.50	3.00	4.50	4.75	4.25	3.75	3.75	4.75	4.50	5.00	6.50
3	0.50	1.75	2.50	3.00	3.25	3.25	3.25	4.50	3.50	3.25	3.00
4	0.50	2.25	3.00	3.00	3.00	3.00	4.00	4.25	3.25	3.75	5.50
5	0.75	2.00	3.00	3.50	4.00	3.25	3.00	4.50	3.75	4.25	5.75
6	0.75	1.75	2.25	3.00	3.00	2.75	2.50	4.25	3.50	3.75	3.75
7	0.50	1.75	2.00	2.50	3.00	3.00	3.25	4.00	3.00	3.75	4.75

(Continued)

Table 4 (Continued)

Wave No.	Shock Pressure, psi, at Indicated Elevation, ft										
	+22	+20	+18	+16	+14	+12	+10	+8	+1.0	-1.5	-4.0
<u>swl = 6.9 ft; T = 10 sec; H = 14.0 ft (Continued)</u>											
8	0.75	2.00	2.50	2.50	3.25	3.00	3.00	5.00	3.00	3.50	5.25
9	0.75	2.00	3.25	3.50	4.00	3.75	3.75	5.00	3.25	3.50	3.25
Avg	0.7	2.1	2.9	3.2	3.6	3.2	3.3	4.5	3.4	3.8	4.6
Max	1.00	3.00	4.50	4.75	4.75	3.75	4.00	5.00	4.50	5.00	6.50
Min	0.50	1.75	2.25	2.50	3.00	2.75	2.50	4.00	3.00	3.25	3.00
<u>swl = 6.9 ft; T = 12 sec; H = 13.3 ft</u>											
1	0.50	9.25	11.75	12.25	9.75	7.00	6.00	8.75	8.75	9.25	10.25
2	0.75	9.25	11.50	11.00	7.75	6.25	12.75	18.50	8.25	8.50	9.75
3	0.25	8.25	10.50	11.00	7.75	5.75	11.00	20.00	12.00	11.00	13.25
4	0.50	8.25	10.00	9.75	7.50	6.00	7.00	16.50	8.00	9.00	10.50
5	1.25	9.25	11.50	11.00	8.50	7.00	8.25	20.00	9.25	9.75	11.00
6	0.50	8.00	9.00	8.50	8.25	5.75	5.25	8.00	6.00	6.75	7.50
7	0.50	9.75	11.50	11.00	8.25	6.00	8.00	8.25	7.75	8.00	9.00
8	0.75	8.25	9.75	10.00	9.25	7.00	8.50	10.25	8.25	9.00	9.50
Avg	0.6	8.8	10.7	10.6	8.4	6.3	8.3	13.8	8.5	8.9	10.1
Max	1.25	9.75	11.75	12.25	9.75	7.00	12.75	20.00	12.00	11.00	13.25
Min	0.25	8.00	9.00	8.50	7.50	5.75	5.25	8.00	6.00	6.75	7.50

(Continued)

Table 4 (Continued)

Wave No.	Shock Pressure, psi, at Indicated Elevation, ft										
	+22	+20	+18	+16	+14	+12	+10	+8	+1.0	-1.5	-4.0
<u>swl = 6.9 ft; T = 12 sec; H = 16.0 ft</u>											
1	0.25	5.25	6.75	6.75	5.50	4.00	4.00	5.75	4.25	4.50	4.25
2	0.25	5.00	6.50	7.00	5.50	4.00	3.75	6.75	7.25	8.00	10.50
3	0.25	6.50	7.75	9.50	5.75	4.00	4.50	8.00	5.50	5.50	6.50
4	0.25	6.00	7.25	7.50	6.25	4.25	9.00	18.75	6.00	6.50	7.50
5	0.25	5.00	6.25	4.50	5.25	4.25	3.75	10.25	6.00	6.25	7.25
6	0.25	7.00	8.75	8.75	11.75	10.25	10.25	12.50	5.75	6.00	6.50
7	0.25	6.00	6.25	6.75	6.50	4.25	4.00	13.00	6.00	6.50	7.50
8	0.25	5.75	7.00	7.75	6.00	6.00	6.00	10.25	6.25	6.75	8.00
<u>swl = 6.9 ft; T = 12 sec; H = 14.0 ft</u>											
AVG	0.25	5.8	7.1	7.3	6.6	5.1	5.7	10.7	5.9	6.2	7.2
Max	0.25	7.00	8.75	9.50	11.75	10.25	10.25	18.75	7.25	8.00	10.50
Min	0.25	5.00	6.25	4.50	5.25	4.00	3.75	5.75	4.25	4.50	4.25
<u>swl = 6.9 ft; T = 12 sec; H = 14.0 ft</u>											
1	0.50	3.50	4.75	5.75	4.00	3.75	3.75	5.00	3.75	3.75	4.25
2	0.50	4.25	6.50	7.25	4.75	4.00	3.00	5.25	4.00	4.50	6.00
3	0.25	4.50	6.00	6.00	4.50	4.00	4.00	5.25	4.75	5.00	5.50
4	0.25	5.00	6.75	7.50	5.00	4.00	4.00	6.00	5.75	6.50	8.50
5	0.25	3.50	4.75	5.50	4.25	3.75	3.00	7.50	5.00	6.00	7.50
6	0.25	4.50	5.50	6.00	4.75	3.75	4.25	12.25	4.50	5.75	6.50
7	0.25	4.75	6.00	6.00	5.00	4.00	3.75	12.25	4.25	5.25	6.75

(Continued)

Table 4 (Continued)

Wave No.	Shock Pressure, psi, at Indicated Elevation, ft										
	+22	+20	+18	+16	+14	+12	+10	+8	+1.0	-1.5	-4.0
<u>swl = 6.9 ft; T = 12 sec; H = 14.0 ft (Continued)</u>											
8	0.25	4.00	5.50	6.00	4.50	4.00	11.25	15.00	6.00	6.75	8.00
9	0.25	4.25	5.25	6.00	4.00	4.00	3.75	8.25	4.25	5.00	6.00
Avg	0.3	4.2	5.7	6.2	4.5	3.9	4.5	8.6	4.7	5.4	6.6
Max	0.50	5.00	6.75	7.50	5.00	4.00	11.25	15.00	6.00	6.75	8.50
Min	0.25	3.50	4.75	5.50	4.00	3.75	3.00	5.00	3.75	3.75	4.25
<u>swl = 6.9 ft; T = 12 sec; H = 12.0 ft</u>											
1	0.50	2.50	3.50	3.75	3.00	2.75	3.00	4.00	3.25	3.50	4.00
2	0.50	3.00	3.50	3.75	3.25	2.75	3.25	4.25	3.75	4.25	5.00
3	2.00	2.50	3.00	4.75	3.25	3.25	3.50	4.00	4.00	4.00	5.25
4	0.75	2.25	3.00	3.25	3.50	3.00	3.50	3.75	4.00	4.25	5.25
5	1.00	2.75	3.25	3.50	3.50	3.25	3.50	4.00	3.50	4.00	4.50
6	0.50	1.25	3.00	2.50	2.75	2.75	3.75	4.00	4.00	5.00	5.00
7	1.25	1.75	3.00	3.25	3.50	3.00	3.75	7.00	4.25	4.75	6.00
8	1.00	1.75	3.00	4.25	3.25	3.25	3.50	4.25	3.75	4.25	4.75
Avg	0.9	2.2	3.2	3.6	3.2	3.0	3.5	4.4	3.8	4.2	5.0
Max	2.00	3.00	3.50	4.75	3.50	3.25	3.75	7.00	4.25	5.00	6.00
Min	0.50	1.25	3.00	2.50	2.75	2.75	3.00	3.75	3.25	3.50	4.00

(Continued)

Table 4 (Continued)

Wave No.	Shock Pressure, psi, at Indicated Elevation, ft										
	+22	+20	+18	+16	+14	+12	+10	+8	+1.0	-1.5	-4.0
<u>swl = 6.9 ft; T = 14 sec; H = 12.0 ft</u>											
1	0.50	5.25	6.25	6.25	5.00	4.25	4.25	5.75	4.50	4.50	4.75
2	1.25	4.25	5.25	5.50	5.00	4.50	4.50	5.25	4.50	4.75	4.75
3	0.50	5.25	6.25	6.50	6.00	5.00	4.75	5.25	4.75	5.00	5.00
4	0.50	4.75	6.25	6.00	5.50	4.75	4.50	5.00	4.75	4.75	4.75
5	0.50	4.75	5.50	5.75	5.25	4.75	4.75	5.25	4.50	4.75	4.50
6	0.50	4.50	5.75	5.75	5.25	5.00	4.75	5.50	5.00	5.00	4.75
7	0.50	4.50	5.25	5.50	5.00	4.75	4.75	5.50	4.25	4.75	4.50
<u>swl = 6.9 ft; T = 14 sec; H = 14.0 ft</u>											
Avg	0.6	4.8	5.8	5.9	5.3	4.7	4.6	5.4	4.6	4.8	4.7
Max	1.25	5.25	6.25	6.50	6.00	5.00	4.75	5.75	5.00	5.00	5.00
Min	0.50	4.25	5.25	5.50	5.00	4.25	4.25	5.00	4.50	4.50	4.75
<u>swl = 6.9 ft; T = 14 sec; H = 14.0 ft</u>											
1	0.75	5.25	5.75	6.50	5.25	4.50	4.50	6.00	4.75	4.75	5.00
2	1.25	4.50	5.50	5.75	5.00	5.00	4.75	5.75	4.50	4.75	5.00
3	0.75	6.00	7.00	7.25	5.75	4.75	4.75	6.00	5.00	5.25	5.75
4	0.50	5.50	6.50	6.75	6.00	5.25	4.75	6.00	5.00	5.00	5.25
5	1.00	6.50	7.25	7.25	6.75	6.00	5.75	6.50	5.00	5.00	5.50
6	0.75	5.75	7.00	7.00	6.25	5.25	5.25	6.00	5.00	5.25	5.50
7	0.75	5.25	6.75	6.75	6.00	5.00	5.00	6.00	4.75	5.00	5.25
<u>swl = 6.9 ft; T = 14 sec; H = 14.0 ft</u>											
Avg	0.8	5.5	6.5	6.8	5.9	5.1	5.0	6.0	4.9	5.0	5.3
Max	1.25	6.00	7.25	7.25	6.75	6.00	5.75	6.50	5.00	5.25	5.75
Min	0.50	4.50	5.50	5.75	5.00	4.50	4.50	5.75	4.50	4.75	5.00

(Continued)

Table 4 (Continued)

Wave No.	Shock Pressure, psi, at Indicated Elevation, ft										
	+22	+20	+18	+16	+14	+12	+10	+8	+1.0	-1.5	-4.0
swl = 6.9 ft; T = 14 sec; H = 16.3 ft											
1	1.25	7.25	8.25	8.50	6.50	5.50	5.75	7.00	5.25	5.25	5.25
2	0.75	6.25	7.50	7.50	6.75	6.00	5.75	6.50	5.25	5.25	5.50
3	0.50	7.75	9.50	9.00	7.50	6.00	6.00	7.00	5.50	5.25	5.50
4	0.50	6.25	8.00	7.75	7.25	6.00	6.00	7.00	5.25	5.25	5.50
5	0.50	8.25	11.50	20.00	8.50	7.00	6.50	7.00	5.25	5.25	5.50
6	1.25	7.50	9.50	8.75	8.75	7.00	6.75	7.25	5.25	5.25	5.50
7	1.00	6.25	8.25	7.75	6.75	6.00	6.00	7.00	5.00	5.25	5.50
swl = 6.9 ft; T = 14 sec; H = 11.2 ft											
AVG	0.8	7.1	8.9	9.9	7.4	6.2	6.1	7.0	5.2	5.2	5.5
Max	1.25	8.25	11.50	20.00	8.75	7.00	6.75	7.25	5.50	5.25	5.50
Min	0.50	6.25	7.50	7.50	6.50	5.50	5.75	6.50	5.00	5.25	5.25
swl = 6.9 ft; T = 14 sec; H = 11.2 ft											
1	0.50	8.75	11.50	12.00	8.50	6.50	7.00	13.50	6.00	6.25	6.50
2	0.50	9.50	11.75	11.50	9.75	8.00	7.50	8.00	7.50	7.75	5.75
3	0.50	10.50	12.50	11.25	9.75	8.25	7.75	10.25	6.75	6.75	7.50
4	1.00	12.50	14.25	13.00	11.00	9.00	8.25	9.00	6.00	6.25	6.50
5	0.50	21.75	21.25	19.25	13.75	10.75	9.75	9.50	6.00	6.50	6.50
6	0.50	12.25	14.25	13.00	10.75	9.00	8.00	8.25	6.00	6.25	6.25
7	1.00	16.75	19.25	16.25	13.75	10.25	8.75	8.75	6.00	6.25	6.50
(Continued)											
AVG	0.6	13.1	15.0	13.8	11.0	8.8	8.1	9.6	6.3	6.6	6.5
Max	1.00	21.75	21.25	19.25	13.75	10.75	9.75	13.50	7.50	7.75	7.50
Min	0.50	8.75	11.50	11.25	8.50	6.50	7.00	8.00	6.00	6.25	5.75

(Continued)

(Sheet 14 of 23)

Table 4 (Continued)

Wave No.	Shock Pressure, psi, at Indicated Elevation, ft										
	+22	+20	+18	+16	+14	+12	+10	+8	+1.0	-1.5	-4.0
swl = 8.6 ft; T = 6 sec; H = 12.5 ft											
1	0.25	1.25	3.00	2.75	3.00	2.00	2.00	5.00	2.00	2.00	2.00
2	0.25	4.25	5.50	6.50	5.00	3.25	4.50	9.25	3.50	3.50	4.25
3	0.25	6.25	6.00	6.75	6.00	3.75	4.75	9.25	3.75	3.75	4.25
4	0.25	3.25	4.50	5.75	3.50	2.25	5.50	5.75	2.25	2.25	3.00
5	0.25	2.50	3.75	4.50	4.25	3.75	9.00	10.25	3.75	2.75	4.00
6	0.50	1.75	3.00	4.25	4.00	3.25	3.25	6.75	2.50	3.50	3.25
7	2.00	4.50	5.25	5.75	4.00	6.75	3.00	9.25	2.75	2.50	3.50
8	0.25	3.00	4.75	5.00	4.00	2.75	3.75	6.75	2.75	2.75	3.00
9	0.50	3.00	4.50	5.00	5.00	2.75	6.75	8.50	3.50	3.25	3.75
10	0.50	3.25	5.00	5.25	4.25	3.00	4.50	7.25	3.50	3.25	3.50
Avg	0.5	3.3	4.5	5.2	4.4	3.4	4.7	7.8	3.0	3.0	3.4
Max	2.00	4.50	6.00	6.75	6.00	6.75	9.00	10.25	3.75	3.75	4.25
Min	0.25	1.25	3.00	2.75	3.00	2.00	2.00	5.00	2.00	2.00	2.00

swl = 8.6 ft; T = 8 sec; H = 14.1 ft

1	0.25	6.25	8.00	9.50	7.75	6.25	7.00	12.25	5.75	5.75	6.25
2	0.25	2.00	2.50	3.00	3.50	2.75	2.75	5.00	2.50	2.50	2.50
3	0.25	8.25	9.50	10.00	8.00	7.00	10.00	12.00	6.25	6.75	7.50
4	0.25	6.25	7.50	8.25	6.25	5.00	8.25	13.75	7.50	8.00	9.00
5	0.25	4.75	6.75	8.00	6.25	4.75	10.25	15.50	7.00	7.50	9.25
6	0.25	5.75	6.25	11.25	5.25	9.00	5.50	10.00	4.75	5.25	6.25
7	0.25	6.25	7.50	8.00	7.25	5.25	5.00	6.00	5.25	6.00	7.00
8	0.25	8.25	10.50	8.00	7.25	5.00	5.00	6.25	6.00	6.25	7.00

(Continued)

Table 4 (Continued)

Wave No.	Shock Pressure, psi, at Indicated Elevation, ft										
	+22	+20	+18	+16	+14	+12	+10	+8	+1.0	-1.5	-4.0
<u>swl = 8.6 ft; T = 8 sec; H = 14.1 ft (Continued)</u>											
9	0.25	5.50	5.50	5.75	5.00	4.50	4.00	6.25	6.00	6.25	7.75
10	0.25	5.50	5.25	6.00	5.00	4.00	4.00	8.25	8.00	8.25	11.00
Avg	0.25	5.9	6.9	7.8	6.2	5.4	6.2	9.5	5.9	6.2	7.4
Max	0.25	8.25	10.50	11.25	8.00	9.00	10.25	15.50	8.00	8.25	11.00
Min	0.25	2.00	2.50	3.00	3.50	2.75	2.75	5.00	2.50	2.50	2.50
<u>swl = 8.6 ft; T = 10 sec; H = 12.1 ft</u>											
1	0.50	3.50	5.25	5.75	5.00	4.25	4.50	5.75	3.75	4.50	5.00
2	0.50	2.25	3.25	4.00	4.00	4.75	4.00	5.00	4.25	5.25	6.75
3	0.75	3.00	4.00	4.75	4.50	4.00	4.50	5.00	3.75	4.25	4.00
4	0.50	1.50	2.50	3.50	3.50	3.50	3.75	4.25	3.75	4.50	5.25
5	0.50	3.00	4.00	4.00	4.25	4.00	4.00	4.50	3.25	4.25	6.00
6	0.25	2.75	2.50	4.50	4.50	4.00	4.25	5.00	3.50	3.75	3.50
7	0.25	3.00	3.25	4.50	4.75	4.00	4.25	5.00	3.75	4.00	4.00
8	0.75	2.75	2.50	4.50	4.25	4.00	4.00	5.00	3.75	4.00	4.50
9	0.50	3.00	4.25	5.00	3.50	4.00	4.00	5.00	3.75	4.50	6.00
Avg	0.5	2.8	3.5	4.5	4.2	4.1	4.1	4.9	3.7	4.3	5.0
Max	0.75	3.50	5.25	5.75	5.00	4.75	4.50	5.75	4.25	5.25	6.75
Min	0.25	1.50	2.50	3.50	3.50	3.50	3.75	4.25	3.25	3.75	3.50

(Continued)

Table 4 (Continued)

Wave No.	Shock Pressure, psi, at Indicated Elevation, ft										
	+22	+20	+18	+16	+14	+12	+10	+8	+1.0	-1.5	-4.0
<u>swl = 8.6 ft; T = 10 sec; H = 14.8 ft</u>											
1	0.50	6.50	8.00	7.75	7.25	6.00	6.00	7.00	5.25	7.00	9.50
2	0.50	3.50	5.25	5.50	5.25	5.25	6.75	6.00	3.25	4.75	6.50
3	0.25	5.50	6.50	6.75	6.25	6.00	5.75	6.00	4.25	5.00	5.00
4	0.50	2.50	4.25	4.50	5.00	4.75	4.75	5.75	3.75	3.75	3.75
5	1.00	4.00	5.50	5.75	5.75	5.00	5.00	6.00	6.00	7.25	10.00
6	1.75	3.25	5.25	5.25	5.50	5.00	5.00	6.00	4.75	5.75	7.50
7	1.00	4.00	6.00	5.75	6.25	5.75	5.75	7.00	5.00	5.25	7.00
8	0.50	4.25	5.50	5.25	5.00	5.00	4.75	5.75	4.00	5.00	6.25
9	0.50	4.00	5.25	5.25	5.00	4.75	4.75	6.00	4.00	4.75	6.00
<u>swl = 8.6 ft; T = 10 sec; H = 15.8 ft</u>											
Avg	0.7	4.2	5.7	5.8	5.7	5.3	5.4	6.2	4.5	5.4	6.8
Max	1.75	6.50	8.00	7.75	7.25	6.00	6.75	7.00	6.00	7.25	10.00
Min	0.25	2.50	4.25	4.50	5.00	4.75	4.75	5.75	3.25	3.75	3.75
1	0.25	7.50	9.50	9.25	8.50	7.25	6.75	7.25	5.50	6.25	9.25
2	0.25	7.25	8.00	7.75	7.50	5.00	4.75	6.00	5.00	5.00	7.00
3	0.25	7.50	9.50	8.75	7.50	6.25	6.25	7.00	5.25	5.00	5.50
4	0.25	4.50	6.00	6.25	5.75	5.50	5.25	6.00	4.00	4.00	5.50
5	0.25	4.50	6.25	6.25	6.50	6.00	5.50	6.25	5.00	5.25	6.00
6	0.25	5.50	7.00	6.75	7.00	6.50	6.25	7.00	5.00	5.50	7.50
7	0.25	5.50	8.00	7.75	6.50	5.25	5.00	6.50	6.25	6.50	8.75

(Continued)

Table 4 (Continued)

Wave No.	Shock Pressure, psi, at Indicated Elevation, ft										
	+22	+20	+18	+16	+14	+12	+10	+8	+1.0	-1.5	-4.0
<u>swl = 8.6 ft; T = 10 sec; H = 15.8 ft (Continued)</u>											
8	0.25	4.00	5.50	5.50	5.75	5.25	5.25	6.00	4.25	4.25	5.25
9	0.25	4.00	5.25	5.50	5.75	5.50	5.25	6.00	4.50	4.25	6.00
Avg	0.25	5.6	7.2	7.1	6.6	5.8	5.6	6.4	5.0	5.1	6.8
Max	0.25	7.50	9.50	9.25	8.50	7.25	6.75	7.25	6.25	6.50	9.25
Min	0.25	4.00	5.25	5.50	5.75	5.00	4.75	6.00	4.00	4.00	5.25
<u>swl = 8.6 ft; T = 12 sec; H = 12.0 ft</u>											
1	0.50	2.50	3.75	4.00	4.00	3.50	3.75	5.00	3.50	3.75	3.50
2	0.25	2.75	4.00	4.00	3.75	3.75	3.75	4.50	3.25	3.25	3.25
3	0.50	2.50	3.25	3.50	3.50	3.75	3.75	4.75	3.75	3.75	4.00
4	0.50	2.50	3.25	3.75	4.00	4.00	3.75	4.50	3.50	3.50	3.50
5	0.25	3.00	4.25	4.25	4.00	3.75	3.75	5.00	3.75	4.00	3.75
6	0.50	2.75	4.25	4.00	3.75	3.75	3.75	8.75	3.75	4.25	4.25
7	0.50	3.00	4.50	4.75	4.50	3.75	4.00	5.75	4.00	4.00	3.75
Avg	0.4	2.7	3.9	3.9	3.9	3.8	3.8	5.5	3.6	3.8	3.7
Max	0.50	3.00	4.50	4.75	4.50	4.00	4.00	8.75	4.00	4.25	4.25
Min	0.25	2.50	3.25	3.50	3.50	3.50	3.75	4.50	3.25	3.25	3.25

(Continued)

Table 4 (Continued)

Wave No.	Shock Pressure, psi, at Indicated Elevation, ft										
	+22	+20	+18	+16	+14	+12	+10	+8	+1.0	-1.5	-4.0
	<u>swl = 8.6 ft; T = 12 sec; H = 14.0 ft</u>										
1	3.00	4.00	5.25	5.00	5.00	4.50	4.50	5.75	4.50	4.25	4.75
2	2.75	4.75	4.50	4.25	4.25	4.50	4.50	5.75	4.50	3.75	4.00
3	0.50	5.00	6.75	6.50	5.25	4.75	4.75	5.75	4.50	4.25	5.00
4	0.50	5.75	7.25	7.25	5.25	4.50	4.25	6.00	4.25	4.25	4.25
5	0.50	5.25	6.25	7.00	5.25	4.50	4.75	6.00	4.50	4.75	5.50
6	1.00	4.50	5.50	6.00	5.00	4.50	4.75	5.75	4.50	4.25	5.00
7	1.00	7.00	8.50	12.75	6.25	5.25	5.00	6.75	4.75	4.50	4.75
8	1.00	6.00	7.00	6.50	5.50	6.00	5.50	6.75	4.50	4.25	5.00
9	0.50	7.00	8.25	10.00	6.25	5.00	5.25	6.25	4.75	4.25	5.00
10	0.50	4.25	5.75	7.00	4.75	4.00	4.25	5.50	4.50	4.00	4.50
	<u>swl = 8.6 ft; T = 12 sec; H = 16.8 ft</u>										
AVG	1.1	5.2	6.5	7.3	5.3	4.7	4.8	5.9	4.5	4.2	4.8
Max	3.00	7.00	8.50	12.75	6.25	6.00	5.50	6.75	4.75	4.75	5.50
Min	0.50	3.25	4.50	4.75	4.25	4.00	4.25	5.50	4.00	3.75	4.00
	<u>swl = 8.6 ft; T = 12 sec; H = 16.8 ft</u>										
1	0.50	9.50	12.00	12.00	9.25	6.50	6.25	7.25	5.75	5.50	6.50
2	0.50	8.00	10.50	12.00	8.25	6.25	11.50	20.75	6.00	6.50	7.75
3	0.50	9.50	12.00	12.00	9.25	8.50	16.00	14.50	6.75	6.50	7.50
4	0.50	5.50	8.25	10.50	7.25	8.25	10.00	19.50	6.75	7.00	8.50
5	1.50	8.25	16.75	15.00	13.25	9.00	10.00	10.00	6.00	5.75	7.00
6	1.75	6.75	8.25	12.25	8.25	8.75	10.00	12.25	6.00	6.00	7.25
7	2.00	9.50	11.25	13.25	10.25	8.75	6.75	11.50	6.00	5.75	6.75

(Continued)

Table 4 (Continued)

Wave No.	Shock Pressure, psi, at Indicated Elevation, ft										
	+22	+20	+18	+16	+14	+12	+10	+8	+1.0	-1.5	-4.0
8	2.25	8.25	9.75	10.00	12.25	8.25	8.00	10.25	6.00	5.75	6.25
9	2.25	7.75	22.00	22.25	19.00	15.50	7.75	8.50	5.25	5.50	6.25
Avg	1.3	8.1	12.3	13.2	10.8	8.9	9.6	12.7	6.1	6.0	7.1
Max	2.25	9.50	22.00	22.25	19.00	15.50	16.00	20.75	6.75	7.00	8.50
Min	0.50	5.50	8.25	10.00	7.25	6.25	6.25	7.25	5.25	5.50	6.25
<u>swl = 8.6 ft; T = 12 sec; H = 16.8 ft (Continued)</u>											
<u>swl = 8.6 ft; T = 12 sec; H = 16.0 ft</u>											
1	1.25	14.00	15.50	14.00	10.50	8.00	7.50	8.50	6.00	6.75	6.75
2	0.50	8.75	12.25	12.00	9.50	7.50	7.50	10.00	5.50	6.00	6.25
3	1.25	11.50	13.00	12.50	9.75	8.25	16.50	16.25	7.50	8.00	8.75
4	2.00	9.25	9.75	11.75	8.50	9.50	25.50	18.25	6.00	6.50	7.00
5	1.75	16.25	36.25	16.25	14.25	12.25	12.00	12.25	7.00	8.00	8.50
6	1.75	8.75	9.50	15.75	8.00	25.00	19.50	12.25	5.50	6.25	6.50
7	1.75	15.00	14.75	14.00	12.50	10.00	11.25	10.25	6.00	6.25	6.75
8	1.75	13.50	14.50	14.00	10.75	9.25	9.00	11.25	6.25	7.00	7.50
9	3.25	15.75	16.75	16.25	12.50	9.25	12.50	9.25	6.00	7.00	7.00
Avg	1.7	12.5	15.8	14.1	10.7	11.0	13.5	12.0	6.2	6.9	7.2
Max	3.25	16.25	36.25	16.25	14.25	25.00	25.50	18.25	7.50	8.00	8.75
Min	0.50	8.75	9.50	11.75	8.00	7.50	7.50	8.50	5.50	6.00	6.25

(Continued)

(Sheet 20 of 23)

Table 4 (Continued)

Wave No.	Shock Pressure, psi, at Indicated Elevation, ft										
	+22	+20	+18	+16	+14	+12	+10	+8	+1.0	-1.5	-4.0
	<u>swl = 8.6 ft; T = 14 sec; H = 12.0 ft</u>										
1	1.00	7.25	7.25	6.75	6.25	5.25	5.25	6.25	4.75	5.00	4.50
2	1.00	6.25	7.00	6.50	6.75	6.00	6.00	7.00	5.00	5.25	4.50
3	2.50	6.50	7.00	7.50	6.25	6.00	6.00	7.00	5.00	5.25	4.75
4	1.00	8.50	9.00	7.75	7.25	6.00	6.00	7.00	5.00	5.25	4.75
5	1.25	7.50	8.50	7.75	7.25	6.50	6.50	7.00	5.00	5.75	5.00
6	1.00	9.50	8.25	7.75	6.50	6.00	6.00	8.25	5.00	5.50	5.25
7	1.00	9.25	7.00	6.75	6.25	5.75	5.75	6.75	5.00	5.50	5.00
8	1.00	5.50	6.25	6.25	5.75	5.00	5.00	6.00	4.50	5.25	4.50
	<u>swl = 8.6 ft; T = 14 sec; H = 14.0 ft</u>										
Avg	1.2	7.5	7.5	7.1	6.5	5.8	5.8	6.9	4.9	5.3	4.8
Max	2.50	9.50	9.00	7.75	7.25	6.50	6.50	8.25	5.00	5.75	5.25
Min	1.00	5.50	6.25	6.25	5.75	5.00	5.00	6.00	4.50	5.00	4.50
	<u>swl = 8.6 ft; T = 14 sec; H = 14.0 ft</u>										
1	0.25	6.25	8.00	8.50	6.25	5.75	6.00	6.75	5.25	5.25	5.00
2	1.25	8.25	8.75	8.25	7.75	7.00	6.75	7.00	5.25	5.50	5.50
3	0.50	9.25	9.50	9.25	8.50	7.25	6.75	9.25	5.25	5.50	5.50
4	1.00	10.50	10.00	9.00	8.25	7.25	7.25	8.25	5.50	5.50	5.50
5	1.00	7.75	10.75	10.00	8.50	7.25	7.00	7.25	5.50	5.50	5.75
6	1.25	12.00	12.00	11.00	8.25	6.50	6.75	7.25	6.00	5.75	6.00

(Continued)

Table 4 (Continued)

Wave No.	Shock Pressure, psi, at Indicated Elevation, ft										
	+22	+20	+18	+16	+14	+12	+10	+8	+1.0	-1.5	-4.0
7	0.25	9.75	9.50	9.00	7.25	6.50	6.50	7.00	5.50	5.50	5.75
8	0.25	10.00	10.75	10.00	8.50	6.75	6.50	7.25	5.50	5.50	6.00
Avg	0.7	2.7	9.9	9.4	7.9	6.8	6.7	7.5	5.5	5.5	5.6
Max	1.25	12.00	12.00	11.00	8.50	7.25	7.25	9.25	6.00	5.75	6.00
Min	0.25	6.25	8.00	8.25	6.25	5.75	6.00	6.75	5.25	5.25	5.00
<u>swl = 8.6 ft; T = 14 sec; H = 14.0 ft (Continued)</u>											
<u>swl = 8.6 ft; T = 14 sec; H = 17.0 ft</u>											
1	1.00	13.00	13.50	12.50	10.25	8.50	7.75	8.25	6.00	6.25	6.50
2	1.50	10.00	11.75	11.00	9.75	8.50	8.00	8.50	5.75	6.00	5.75
3	0.75	12.00	13.00	12.75	11.75	9.75	8.75	9.50	6.00	6.25	6.75
4	1.00	16.00	15.50	14.00	11.75	9.50	8.50	9.50	6.25	6.25	7.25
5	1.00	17.75	17.75	16.00	13.00	11.00	10.00	10.25	6.75	6.75	7.50
6	1.75	28.00	21.50	18.25	14.25	11.25	10.50	8.75	7.00	7.00	7.50
7	1.50	16.00	15.25	14.25	12.00	10.25	9.25	10.00	7.00	6.75	7.50
8	1.50	10.00	18.75	11.00	10.75	9.00	8.75	9.50	6.25	6.50	7.25
9	1.50	16.25	16.75	14.75	11.50	8.75	7.75	9.50	6.50	6.50	7.50
Avg	1.3	15.4	16.0	13.8	11.7	9.6	8.8	9.3	6.4	6.5	7.1
Max	1.75	28.00	21.50	18.25	14.25	11.25	10.50	10.25	7.00	7.00	7.50
Min	0.75	10.00	11.75	11.00	9.75	8.50	7.75	8.25	5.75	6.00	5.75

(Continued)

(Sheet 22 of 23)

Table 4 (Concluded)

Wave No.	Shock Pressure, psi, at Indicated Elevation, ft										
	+22	+20	+18	+16	+14	+12	+10	+8	+1.0	-1.5	-4.0
1	2.50	28.50	28.00	24.25	18.75	15.50	18.00	14.00	9.50	10.00	11.50
2	3.25	67.50	53.75	47.00	29.75	22.50	19.25	16.75	9.00	9.50	9.25
3	2.00	14.00	17.75	15.50	14.25	11.25	12.00	12.50	8.00	7.75	8.50
4	1.00	38.25	43.50	37.75	25.00	19.75	16.25	14.75	8.75	9.00	9.75
5	6.00	50.75	42.00	51.75	42.50	27.75	21.50	20.25	10.25	11.00	12.50
6	3.50	34.50	47.00	43.75	35.00	26.00	30.25	21.50	10.00	10.00	12.50
7	1.00	30.25	32.75	24.50	19.50	15.50	14.25	13.25	9.25	9.25	10.00
Avg	2.8	37.7	37.8	34.9	26.4	19.8	18.8	16.1	9.2	9.5	10.6
Max	6.00	67.50	53.75	51.75	42.50	27.75	30.25	21.50	10.25	11.00	12.50
Min	1.00	14.00	17.75	15.50	14.25	11.25	12.00	12.50	8.00	9.00	8.50

swl = 8.6 ft; T = 14 sec; H = 11.4 ft

Table 5 (Concluded)

swl ft	Incident Wave		Wave Form	Average Pressure, psi, for Indicated Elevation, ft										
	T, sec	H, ft		+22.0	+20.0	+18.0	+16.0	+14.0	+12.0	+10.0	+8.0	+1.0	-1.5	-4.0
+8.6	6.0	12.5	Breaking	*	*	0.3	0.8	1.4	1.6	2.1	2.6	1.4	1.3	1.0
	8.0	14.1	Breaking	*	0.4	0.8	1.4	2.2	2.3	3.1	3.6	2.7	3.2	2.0
	10.0	12.1	Nonbreaking	*	*	1.0	1.8	2.6	3.0	3.6	4.2	3.9	3.6	3.4
	10.0	14.8	Nonbreaking	0.4	0.5	1.7	2.1	3.1	3.6	4.2	4.8	3.5	3.5	3.3
	10.0	15.8	Breaking	*	0.9	1.5	2.4	3.1	3.8	4.3	4.9	3.2	2.9	2.5
	12.0	12.0	Nonbreaking	0.3	0.5	1.3	1.8	2.7	3.4	4.0	4.4	3.4	3.4	3.0
	12.0	14.0	Nonbreaking	0.3	0.5	1.7	2.2	3.0	3.7	4.2	5.0	3.8	3.7	3.5
	12.0	16.8	Breaking	0.9	0.3	2.5	2.6	3.5	4.4	4.8	5.3	4.3	4.0	3.8
	12.0	16.0	Prebreaking	0.8	*	2.5	2.9	3.9	4.4	4.8	5.4	4.1	4.3	3.9
	14.0	12.0	Nonbreaking	*	*	2.2	2.5	3.8	4.2	4.6	5.0	4.2	4.1	3.8
	14.0	14.0	Nonbreaking	0.5	1.1	2.3	2.6	3.4	3.9	4.4	4.9	4.1	3.9	3.5
	14.0	17.0	Breaking	1.1	1.6	2.5	2.9	3.7	4.5	4.7	5.1	4.2	4.1	3.8
	14.0	11.4	Prebreaking	1.4	*	2.8	3.1	3.8	4.6	4.8	5.4	4.1	4.1	3.7

* Negligible.

Table 6
Shock Pressure Data, Test Series 1, Plan R4S3

Wave No.	Shock Pressure, psi, at Indicated Elevation, ft							
	+21	+20	+18	+16	+14	+12	+10	+8
<u>swl = 6.9 ft; T = 10 sec; H = 14.0 ft</u>								
1	5.00	4.00	4.50	4.00	4.00	4.25	2.00	4.25
2	6.00	5.25	5.25	5.25	4.00	4.25	2.00	4.25
3	5.00	4.50	4.75	5.00	4.00	4.25	2.00	4.25
4	5.00	5.00	5.75	5.75	4.00	4.25	2.00	4.25
5	5.00	5.50	6.00	5.75	4.00	4.25	2.00	4.25
6	6.00	5.75	5.75	5.75	4.00	4.25	2.00	4.25
7	6.00	4.75	5.25	5.25	4.00	4.25	2.00	4.25
Avg	5.4	5.0	5.3	5.2	4.0	4.2	2.0	4.2
Max	6.00	5.75	6.00	5.75	4.00	4.25	2.00	4.25
Min	5.00	4.00	4.50	4.00	4.00	4.25	2.00	4.25

swl = 6.9 ft; T = 10 sec; H = 14.7 ft

1	6.00	6.75	6.75	7.25	6.00	5.25	2.00	4.25
2	8.25	7.75	7.25	7.25	6.00	5.25	2.00	4.25
3	8.25	6.25	6.00	6.00	6.00	5.25	2.00	5.25
4	5.00	5.50	5.25	5.25	5.00	4.25	2.00	5.25
5	5.00	7.00	6.75	6.50	5.00	4.25	2.00	5.25
6	5.00	5.75	6.00	5.75	5.00	4.25	2.00	5.25
7	4.00	5.75	5.25	5.00	5.00	4.25	2.00	5.25
Avg	5.9	6.0	6.2	6.1	5.4	4.7	2.0	5.0
Max	8.25	7.75	7.25	7.25	6.00	5.25	2.00	5.25
Min	4.00	5.50	5.25	5.00	5.00	4.25	2.00	4.25

swl = 6.9 ft; T = 10 sec; H = 15.7 ft

1	9.25	7.00	6.75	7.00	6.00	4.25	3.00	6.25
2	8.25	9.75	8.75	8.50	7.00	5.25	4.25	5.25
3	9.25	14.75	7.75	7.25	7.00	5.25	4.25	6.25
4	13.25	8.25	8.50	8.25	7.00	6.25	4.25	5.25
5	7.00	9.00	12.00	7.75	7.00	5.25	4.25	6.25
6	8.25	8.75	8.50	8.25	7.00	5.25	4.25	6.25
7	9.25	6.75	7.25	6.50	7.00	5.25	4.25	8.50
Avg	9.2	9.2	8.5	7.6	6.9	5.2	4.1	6.3
Max	13.25	14.75	12.00	8.50	7.00	6.25	4.25	8.50
Min	7.00	6.75	6.75	6.50	6.00	4.25	3.00	5.25

(Continued)

(Sheet 1 of 8)

Table 6 (Continued)

Wave No.	Shock Pressure, psi, at Indicated Elevation, ft							
	+21	+20	+18	+16	+14	+12	+10	+8
<u>swl = 6.9 ft; T = 12 sec; H = 12.0 ft</u>								
1	*	2.75	2.75	3.75	3.00	2.00	4.25	4.25
2	*	2.75	2.50	3.75	3.00	2.00	4.25	4.25
3	*	3.00	2.75	3.25	4.00	2.00	4.25	4.25
4	*	3.00	2.75	3.25	4.00	2.00	4.25	5.25
5	*	3.00	2.75	2.75	4.00	2.00	4.25	5.25
6	*	2.50	2.75	2.75	3.00	2.00	4.25	5.25
7	*	2.50	2.75	2.50	3.00	2.00	4.25	5.25
Avg		2.8	2.7	3.1	3.4	2.0	4.2	4.8
Max		3.00	2.75	3.75	4.00	2.00	4.25	5.25
Min		2.50	2.50	2.50	3.00	2.00	4.25	4.25

swl = 6.9 ft; T = 12 sec; H = 14.0 ft

1	6.00	6.25	5.75	6.00	5.00	4.25	4.25	10.50
2	6.00	5.25	4.50	6.50	4.00	3.00	4.25	6.25
3	4.00	5.25	5.25	4.50	4.00	3.00	5.25	6.25
4	9.25	4.00	4.00	4.00	5.00	3.00	4.25	6.25
5	5.00	6.00	5.25	5.00	5.00	5.25	5.25	11.50
6	4.00	4.25	4.00	3.75	5.00	4.25	5.25	7.25
7	6.00	5.75	4.75	8.50	3.00	5.25	11.50	14.75
Avg	5.8	5.2	4.8	5.5	4.4	4.0	5.7	9.0
Max	9.25	6.25	5.75	8.50	5.00	5.25	11.50	14.75
Min	4.00	4.00	4.00	3.75	3.00	3.00	4.25	6.25

swl = 6.9 ft; T = 12 sec; H = 16.0 ft

1	6.00	7.25	6.50	6.50	5.00	4.25	2.00	5.25
2	8.25	5.50	5.75	6.00	4.00	5.25	1.25	6.25
3	6.00	6.50	6.50	6.00	6.00	5.25	1.00	5.25
4	4.00	5.00	4.50	4.00	4.00	4.25	1.00	5.25
5	5.00	6.75	6.00	5.75	5.00	4.25	0.75	8.50
6	4.00	4.75	4.50	5.00	5.00	5.25	1.00	6.25
7	6.00	5.75	7.25	7.25	5.00	4.25	0.75	16.75
Avg	5.6	5.9	5.9	5.8	4.9	4.7	1.1	7.6
Max	8.25	7.25	7.25	7.25	6.00	5.25	2.00	16.75
Min	4.00	4.75	4.50	4.00	4.00	4.25	0.75	5.25

(Continued)

* Negligible.

(Sheet 2 of 8)

Table 6 (Continued)

Wave No.	Shock Pressure, psi, at Indicated Elevation, ft							
	+21	+20	+18	+16	+14	+12	+10	+8
<u>swl = 6.9 ft; T = 12 sec; H = 13.3 ft</u>								
1	11.25	11.25	10.50	8.25	9.00	6.25	6.25	7.25
2	10.25	9.50	9.25	9.00	11.00	8.25	13.50	8.50
3	13.25	12.00	11.75	11.50	9.00	9.25	10.50	14.75
4	14.25	11.75	12.00	13.00	10.00	7.25	6.25	9.50
5	14.25	17.75	13.25	14.75	15.75	11.25	10.50	28.25
6	14.25	12.50	11.25	9.75	9.00	7.25	9.50	11.50
7	18.25	15.50	13.25	13.75	12.00	8.25	10.50	9.50
Avg	13.7	12.9	11.6	11.4	10.8	8.2	9.6	12.8
Max	18.25	17.75	13.25	14.75	15.75	11.25	13.50	28.25
Min	10.25	9.50	9.25	8.25	9.00	6.25	6.25	7.25
<u>swl = 6.9 ft; T = 14 sec; H = 12.0 ft</u>								
1	6.00	5.75	5.75	5.75	5.00	3.00	4.25	36.75
2	5.00	5.75	6.00	5.25	4.00	3.00	3.00	13.75
3	5.00	5.25	5.25	5.25	4.00	3.00	4.25	13.75
4	6.00	6.00	6.00	5.25	7.00	3.00	5.25	14.75
5	5.00	5.75	5.25	5.25	3.00	3.00	5.25	25.25
6	7.00	6.00	5.25	5.25	4.00	5.25	5.25	7.25
7	6.50	5.00	5.25	13.00	6.00	3.00	4.25	20.00
Avg	5.8	5.6	5.5	6.4	4.7	3.3	4.5	18.8
Max	7.00	6.00	6.00	13.00	7.00	5.25	5.25	36.75
Min	5.00	5.00	5.25	5.25	3.00	3.00	3.00	7.25
<u>swl = 6.9 ft; T = 14 sec; H = 14.0 ft</u>								
1	8.25	7.25	6.50	7.00	6.00	4.25	9.50	15.75
2	10.25	7.50	6.75	7.00	6.00	5.25	4.25	5.25
3	7.00	7.25	7.25	6.00	6.00	5.25	5.25	17.75
4	8.25	7.00	6.00	6.50	5.00	4.25	3.00	11.50
5	6.00	5.50	12.00	11.00	6.00	6.25	6.25	21.00
6	7.00	6.25	5.25	10.50	10.00	6.25	4.25	17.75
7	8.25	7.00	12.00	5.75	4.00	4.25	7.25	40.00
Avg	7.9	6.8	8.0	7.7	6.1	5.1	5.7	18.4
Max	10.25	7.50	12.00	11.00	10.00	6.25	9.50	40.00
Min	6.00	5.50	5.25	5.75	4.00	4.25	3.00	5.25

(Continued)

(Sheet 3 of 8)

Table 6 (Continued)

Wave No.	Shock Pressure, psi, at Indicated Elevation, ft							
	+21	+20	+18	+16	+14	+12	+10	+8
<u>swl = 6.9 ft; T = 14 sec; H = 16.3 ft</u>								
1	9.25	9.50	8.75	8.50	7.00	6.25	7.25	10.50
2	11.25	9.75	8.50	8.25	6.00	5.25	5.25	11.50
3	10.25	9.75	8.75	7.75	7.00	4.25	5.25	15.75
4	11.25	10.75	8.50	8.50	6.00	4.25	6.25	11.50
5	10.25	9.25	8.00	8.50	7.00	5.25	5.25	16.75
6	10.25	8.50	7.75	6.50	6.00	4.25	5.25	27.25
7	7.00	7.25	27.50	10.50	5.00	6.25	8.25	31.50
Avg	9.9	9.2	11.1	8.4	6.3	5.1	6.1	17.8
Max	11.25	10.75	27.50	10.50	7.00	6.25	8.25	31.50
Min	7.00	7.25	7.75	6.50	5.00	4.25	5.25	10.50

swl = 6.9 ft; T = 14 sec; H = 11.2 ft

1	18.25	15.25	13.75	12.50	10.00	8.25	8.25	47.25
2	17.25	14.75	12.50	12.25	11.00	9.25	12.50	31.50
3	16.25	14.75	13.00	12.50	9.00	7.25	12.50	77.75
4	18.25	14.75	13.00	12.25	10.00	7.25	9.50	34.75
5	15.25	13.25	12.00	11.00	9.00	7.25	7.25	15.75
6	15.25	13.75	12.00	13.50	12.00	7.25	11.50	110.25
7	13.25	10.50	9.25	9.00	8.00	6.25	5.25	33.50
Avg	16.2	13.9	12.2	11.9	9.9	7.5	9.5	50.1
Max	18.25	15.25	13.75	13.50	12.00	9.25	12.50	110.25
Min	13.25	10.50	9.25	9.00	8.00	6.25	5.25	15.75

swl = 8.6 ft; T = 10 sec; H = 12.1 ft

1	3.00	3.75	3.25	3.75	4.00	4.25	4.25	9.50
2	6.00	5.00	4.75	5.00	5.00	5.25	4.25	5.25
3	7.00	4.00	4.00	4.50	5.00	4.25	4.25	5.25
4	5.00	4.50	4.50	5.25	5.00	4.25	4.25	5.25
5	5.00	4.75	4.50	5.25	6.00	4.25	4.25	5.25
6	5.00	5.00	5.25	5.25	6.00	4.25	4.25	5.25
7	5.00	4.25	4.75	3.75	5.00	4.25	4.25	5.25
Avg	5.1	4.5	4.4	4.7	5.1	4.4	4.2	5.9
Max	7.00	5.00	5.25	5.25	6.00	5.25	4.25	9.50
Min	3.00	3.75	3.25	3.75	4.00	4.25	4.25	5.25

(Continued)

(Sheet 4 of 8)

Table 6 (Continued)

Wave No.	Shock Pressure, psi, at Indicated Elevation, ft							
	+21	+20	+18	+16	+14	+12	+10	+8
<u>swl = 8.6 ft; T = 10 sec; H = 14.8 ft</u>								
1	9.25	6.75	6.75	6.50	6.00	6.25	3.00	6.25
2	12.25	10.25	10.00	9.25	8.00	7.25	5.25	7.25
3	8.25	6.75	7.75	7.75	6.00	6.25	4.25	6.25
4	8.25	7.25	7.25	7.00	7.00	6.25	4.25	6.25
5	14.25	6.75	7.25	7.00	7.00	7.25	4.25	7.25
6	9.25	8.25	7.75	7.25	7.00	6.25	4.25	5.25
7	8.25	7.75	7.75	7.00	7.00	6.25	4.25	5.25
Avg	10.0	7.7	7.8	7.4	6.9	6.5	4.2	6.2
Max	14.25	10.25	10.00	9.25	8.00	7.25	5.25	7.25
Min	8.25	6.75	6.75	6.50	6.00	6.25	3.00	5.25

swl = 8.6 ft; T = 10 sec; H = 15.8 ft

1	11.25	10.25	10.00	9.25	7.00	7.25	5.25	5.25
2	13.25	11.00	11.00	9.75	10.00	8.25	7.25	7.25
3	9.25	7.75	8.50	8.50	7.00	7.25	7.25	7.25
4	10.25	9.75	10.50	9.75	9.00	8.25	7.25	6.25
5	7.00	19.00	11.00	8.25	8.00	7.25	6.25	7.25
6	9.25	10.75	9.25	8.50	8.00	7.25	6.25	6.25
7	7.00	7.75	10.00	7.75	7.00	6.25	5.25	5.25
Avg	8.6	10.9	10.0	8.8	8.0	7.4	6.4	6.4
Max	13.25	19.00	11.00	9.75	10.00	8.25	7.25	7.25
Min	7.00	7.75	8.50	7.75	7.00	6.25	5.25	5.25

swl = 8.6 ft; T = 12 sec; H = 12.0 ft

1	4.00	4.25	4.75	5.00	5.00	4.25	4.25	3.25
2	5.00	4.75	4.75	4.50	5.00	4.25	4.25	3.25
3	6.00	5.00	5.25	4.50	5.00	4.25	4.25	4.25
4	6.00	4.75	4.50	4.50	5.00	4.25	4.25	4.25
5	5.00	5.00	4.50	4.50	4.00	4.25	4.25	4.25
6	3.00	3.25	3.25	2.75	4.00	4.25	4.25	27.25
7	4.00	4.00	3.75	3.75	4.00	4.25	4.25	4.25
Avg	4.7	4.4	4.4	4.2	4.6	4.2	4.2	7.2
Max	4.00	5.00	5.25	5.00	5.00	4.25	4.25	27.25
Min	3.00	3.25	3.25	2.75	4.00	4.25	4.25	3.25

(Continued)

(Sheet 5 of 8)

Table 6 (Continued)

Wave No.	Shock Pressure, psi, at Indicated Elevation, ft							
	+21	+20	+18	+16	+14	+12	+10	+8
<u>swl = 8.6 ft; T = 12 sec; H = 14.0 ft</u>								
1	9.25	7.00	7.25	6.50	8.00	6.25	4.25	5.25
2	8.25	6.50	6.00	5.75	6.00	5.25	4.25	5.25
3	7.00	6.00	6.50	6.00	7.00	6.25	6.25	12.50
4	7.00	5.75	5.25	5.00	7.00	5.25	11.50	8.50
5	7.00	6.75	6.50	5.75	5.00	5.25	13.50	9.50
6	7.00	5.25	4.50	8.25	7.00	22.75	15.75	8.50
7	9.25	7.25	6.50	5.75	5.00	41.25	16.75	10.50
Avg	7.8	6.4	6.1	6.1	6.4	13.2	10.3	8.6
Max	9.25	7.25	7.25	8.25	8.00	41.25	16.75	12.50
Min	7.00	5.25	4.50	5.00	5.00	5.25	4.25	5.25
<u>swl = 8.6 ft; T = 12 sec; H = 16.8 ft</u>								
1	14.25	10.75	9.25	8.50	9.00	6.25	6.25	6.25
2	13.25	11.25	16.25	12.25	9.00	6.25	10.50	11.50
3	12.25	11.25	10.00	16.25	7.00	8.25	23.00	11.50
4	14.25	11.75	9.75	13.75	8.00	18.50	15.50	9.50
5	20.25	20.50	20.50	16.25	17.75	17.50	20.75	12.50
6	12.25	13.50	13.00	16.25	17.75	29.00	18.75	12.50
7	23.50	18.00	15.00	16.25	15.75	16.50	12.50	10.50
Avg	15.7	13.9	13.4	14.2	12.0	14.6	15.3	10.6
Max	23.50	20.50	20.50	16.25	17.75	29.00	23.00	12.50
Min	12.25	10.75	9.25	8.50	7.00	6.25	6.25	6.25
<u>swl = 8.6 ft; T = 12 sec; H = 16.0 ft</u>								
1	20.25	16.75	14.50	13.50	12.00	8.25	6.25	6.25
2	21.25	17.50	14.50	12.50	13.00	7.25	9.50	10.50
3	23.50	21.50	17.25	14.25	18.75	11.25	29.25	21.00
4	25.50	21.50	19.25	18.25	16.75	11.25	25.00	17.75
5	56.00	26.25	27.00	24.75	16.75	15.50	11.50	10.50
6	34.50	26.25	25.00	21.50	16.75	17.50	16.75	12.50
7	29.50	20.00	21.25	18.75	28.75	19.75	25.00	9.50
Avg	30.1	21.4	19.8	17.6	17.5	13.0	17.6	12.6
Max	56.00	26.25	27.00	24.75	28.75	19.75	29.25	21.00
Min	20.25	16.75	14.50	12.50	12.00	8.25	6.25	6.25

(Continued)

(Sheet 6 of 8)

Table 6 (Continued)

Wave No.	Shock Pressure, psi, at Indicated Elevation, ft							
	+21	+20	+18	+16	+14	+12	+10	+8
<u>swl = 8.6 ft; T = 14 sec; H = 12.0 ft</u>								
1	11.25	7.75	6.75	7.25	7.00	6.25	5.25	4.25
2	13.25	8.75	8.50	7.75	8.00	7.25	6.25	5.25
3	11.25	9.50	8.75	7.75	7.00	6.25	15.50	6.25
4	13.25	10.25	8.75	7.25	8.00	6.25	6.25	6.25
5	13.25	9.50	8.50	7.25	7.00	6.25	5.25	5.25
6	12.25	9.00	7.75	7.25	6.00	6.25	5.25	5.25
7	12.25	8.50	7.75	6.50	7.00	5.25	9.50	5.25
Avg	12.4	9.0	8.1	7.3	7.1	6.2	7.6	5.4
Max	13.25	10.25	8.75	7.75	8.00	7.25	15.50	6.25
Min	11.25	7.75	6.75	6.50	6.00	5.25	5.25	4.25

swl = 8.6 ft; T = 14 sec; H = 14.0 ft

1	15.25	11.75	11.00	10.25	11.00	8.25	16.75	7.25
2	15.25	12.00	10.50	9.75	10.00	7.25	6.25	6.25
3	12.25	10.25	9.25	8.25	8.00	7.25	32.25	14.75
4	12.25	10.25	9.25	9.00	9.00	8.25	15.50	26.25
5	11.25	10.25	9.75	9.00	9.00	7.25	7.25	6.25
6	15.25	11.25	10.00	9.25	9.00	9.25	6.25	5.25
7	12.25	9.75	9.25	8.50	8.00	8.25	5.25	5.25
Avg	13.4	10.8	9.9	9.1	9.1	8.0	12.8	10.2
Max	15.25	12.00	11.00	10.25	11.00	9.25	32.25	26.25
Min	11.25	9.75	9.25	8.25	8.00	7.25	5.25	5.25

swl = 8.6 ft; T = 14 sec; H = 17.0 ft

1	22.25	17.50	15.75	14.25	14.00	11.25	10.50	10.50
2	22.25	15.50	13.25	12.25	12.00	9.25	9.50	9.50
3	18.25	15.25	14.50	13.50	13.00	13.50	10.50	10.50
4	17.25	15.25	14.00	13.00	14.00	12.50	9.50	10.50
5	18.25	15.25	14.50	13.00	13.00	10.25	9.50	9.50
6	14.25	12.25	12.00	10.50	10.00	9.25	15.50	10.50
7	15.25	11.75	11.00	10.25	10.00	9.25	7.25	5.25
Avg	18.2	14.7	13.6	12.4	12.3	10.8	10.3	9.5
Max	22.25	17.50	15.75	14.25	14.00	13.50	15.50	10.50
Min	14.25	11.75	11.00	10.25	10.00	9.25	7.25	5.25

(Continued)

(Sheet 7 of 8)

Table 6 (Concluded)

Wave No.	Shock Pressure, psi, at Indicated Elevation, ft							
	+21	+20	+18	+16	+14	+12	+10	+8
<u>swl = 8.6 ft; T = 14 sec; H = 11.4 ft</u>								
1	26.50	22.00	19.75	18.00	17.75	14.50	12.50	10.50
2	33.50	25.50	23.75	21.25	19.75	16.50	15.50	15.75
3	44.75	32.50	30.25	26.75	24.75	18.50	15.50	13.75
4	75.25	32.00	41.25	34.25	27.75	20.75	18.75	13.75
5	39.75	32.00	29.00	26.50	23.75	18.50	15.50	13.75
6	25.50	21.00	19.00	18.00	15.00	13.50	12.50	10.50
7	26.50	22.50	21.00	18.75	29.75	15.50	12.50	10.50
Avg	38.8	26.8	26.3	23.4	22.6	16.8	14.7	12.6
Max	75.25	32.50	41.25	34.25	29.75	20.75	18.75	15.75
Min	25.50	21.00	19.00	18.00	15.00	13.50	12.50	10.50

Table 7

Average Secondary Wave Pressures on Modified Recurved Seawall, Plan R4S3

swl ft	Incident Wave		Wave Form	Average Pressure, psi, for Indicated Elevation, ft								
	T, sec	H, ft		+21.0	+20.0	+18.0	+16.0	+14.0	+12.0	+10.0	+8.0	
+6.9	10.0	14.0	Nonbreaking	*	*	1.2	1.2	3.0	3.1	2.1	4.2	
	10.0	14.7	Nonbreaking	*	0.6	0.8	1.2	2.0	3.1	3.1	3.1	
	10.0	15.7	Breaking	*	0.4	1.2	1.2	3.0	3.1	3.1	4.2	
	12.0	12.0	Nonbreaking	*	*	0.8	1.2	2.0	2.1	4.2	4.2	
	12.0	14.0	Nonbreaking	*	*	0.8	1.6	3.0	3.1	4.2	4.2	
	12.0	16.0	Breaking	*	0.4	0.8	1.2	2.0	4.1	3.1	5.3	
	12.0	13.3	Prebreaking	*	0.6	1.2	1.6	4.1	3.1	4.2	4.2	
	14.0	12.0	Nonbreaking	*	*	1.2	1.6	3.0	3.1	3.1	4.2	
	14.0	14.0	Nonbreaking	*	*	1.2	1.6	3.0	4.1	4.2	5.3	
	14.0	16.3	Breaking	*	0.4	1.2	2.0	3.0	3.1	4.2	4.2	
	14.0	11.2	Prebreaking	*	0.4	1.2	2.0	3.0	4.1	4.2	5.3	
	+8.6	10.0	12.1	Nonbreaking	*	0.6	1.2	1.6	4.1	4.1	4.2	4.2
		10.0	14.8	Nonbreaking	*	0.4	1.6	2.0	3.0	4.1	3.1	5.2
		10.0	15.8	Breaking	*	0.4	1.2	2.0	3.0	4.1	4.2	4.2
12.0		12.0	Nonbreaking	*	0.6	1.2	1.6	4.1	4.1	4.2	3.2	
12.0		14.0	Nonbreaking	*	0.6	1.6	2.0	5.1	5.2	4.2	4.2	
12.0		16.8	Breaking	*	1.2	2.0	2.4	4.1	4.1	5.2	5.2	
12.0		16.0	Prebreaking	*	1.4	2.4	2.8	5.1	4.1	5.2	4.2	
14.0		12.0	Nonbreaking	*	0.6	1.6	2.0	3.0	5.2	5.2	5.2	
14.0		14.0	Nonbreaking	*	0.6	1.6	2.0	5.1	5.2	5.2	5.2	
14.0		17.0	Breaking	*	1.2	2.0	2.8	5.1	5.2	5.2	5.2	
14.0		11.4	Prebreaking	*	1.6	2.8	3.3	5.1	5.2	6.2	6.3	

* Negligible.

Table 8

Instantaneous Wave Pressures on Recurved Seawall, Plan R4S2

Time Relative to Peak sec	Wave Pressure, psi, at Indicated Elevation, ft										
	+22	+20	+18	+16	+14	+12	+10	+8	+1.0	-1.5	-4.0
	<u>swl = +8.6; T = 12 sec; H = 12.0 ft</u>										
-0.500	0.00	0.00	0.00	-0.25	-0.25	0.00	-0.25	-0.75	2.00	2.25	2.00
-0.200	0.25	0.25	0.50	0.00	1.00	1.00	1.75	3.50	3.00	3.00	2.75
-0.100	0.00	0.00	0.00	2.00	1.75	1.75	2.50	3.50	3.25	3.25	3.00
-0.025	-0.50	0.50	1.50	2.75	2.50	2.00	2.25	3.25	2.75	2.75	2.75
Peak	-0.50	1.25	2.50	3.50	3.25	2.25	3.25	4.50	2.75	2.75	2.75
+0.025	-4.25	1.25	3.00	3.75	3.25	2.50	2.75	4.25	3.00	2.75	2.75
+0.100	-5.25	2.75	4.00	3.75	3.50	3.25	3.50	4.25	3.00	3.00	2.75
+0.200	-2.00	2.00	3.00	3.25	3.25	3.00	3.25	3.75	2.25	2.50	2.50
+0.500	-0.25	1.25	2.00	2.75	3.25	3.00	3.25	4.00	2.25	2.00	1.75
	<u>swl = +8.6 ft; T = 12 sec; H = 14.0 ft</u>										
-0.500	0.25	0.00	0.50	0.25	0.00	0.25	0.00	0.00	3.00	2.75	3.25
-0.200	0.00	0.00	0.25	0.00	2.25	1.75	3.25	5.00	4.00	4.00	3.75
-0.100	0.25	-0.50	0.50	4.50	3.00	3.00	3.25	4.75	3.50	3.50	3.75
-0.025	-0.50	2.50	6.25	7.00	5.00	4.25	4.25	5.50	4.00	3.75	3.50
Peak	-0.25	4.25	7.25	7.25	5.00	4.25	4.25	5.25	3.75	3.75	3.50
+0.025	0.00	5.50	6.75	7.00	5.25	4.50	4.25	5.50	4.25	4.00	3.75
+0.100	0.00	5.00	5.50	5.50	4.25	3.75	3.75	5.00	3.75	3.00	3.25
+0.200	0.25	2.75	4.50	4.50	4.50	4.50	4.25	5.00	4.00	3.25	3.25
+0.500	0.25	1.00	2.50	3.00	3.25	3.75	4.00	4.75	3.50	2.75	2.50

(Continued)

(Sheet 1 of 4)

Table 8 (Continued)

Time Relative to Peak sec	Wave Pressure, psi, at Indicated Elevation, ft										
	+22	+20	+18	+16	+14	+12	+10	+8	+1.0	-1.5	-4.0
-0.500	0.00	0.00	0.25	-0.25	0.00	0.00	0.00	0.00	0.25	-0.25	-0.50
-0.200	0.25	-0.25	0.50	0.00	0.25	0.00	0.00	0.00	3.75	3.50	4.00
-0.100	0.00	0.00	0.25	0.00	0.25	0.50	2.50	20.75	6.00	6.50	7.75
-0.025	0.25	0.00	0.25	-0.25	0.00	3.75	6.00	5.25	4.75	4.75	4.50
Peak	0.25	0.00	0.25	-0.25	5.25	5.00	7.00	8.25	4.75	4.75	5.00
+0.025	0.50	0.25	0.00	4.00	4.50	3.50	5.50	7.00	4.50	4.25	4.00
+0.100	0.00	2.50	8.00	12.00	7.75	6.00	5.50	5.50	4.75	5.00	4.75
+0.200	0.25	8.50	9.50	9.75	7.25	5.75	5.50	6.00	4.25	4.25	4.25
+0.500	0.50	3.00	4.50	4.50	5.25	5.00	5.00	5.75	3.50	3.25	3.00

swl = +8.6 ft; T = 12 sec; H = 16.8 ft

swl = +8.6 ft; T = 12 sec; H = 16.0 ft

-0.500	0.25	0.00	0.50	0.00	0.25	0.00	0.00	0.00	2.00	2.00	2.00
-0.200	0.50	0.25	0.75	0.25	0.50	0.25	0.25	1.50	4.50	4.75	5.00
-0.100	0.00	0.00	0.25	-0.25	0.00	0.25	0.00	4.00	4.75	5.25	5.75
-0.025	0.25	0.00	0.50	0.00	15.00	9.25	9.25	10.00	5.00	5.75	6.50
Peak	0.75	0.25	36.25	14.00	-2.75	10.75	2.25	5.25	6.50	6.50	6.00
+0.025	0.50	0.00	13.00	11.25	7.50	4.00	3.75	5.75	5.00	5.50	2.25
+0.100	-0.25	14.00	11.50	10.00	9.25	6.00	5.75	6.25	4.50	5.00	4.75
+0.200	0.50	6.25	7.50	7.25	6.00	5.75	6.25	6.75	4.00	4.25	4.00
+0.500	-0.25	1.75	3.25	3.50	4.25	5.00	5.00	5.75	3.50	3.50	3.00

(Continued)

(Sheet 2 of 4)

Table 8 (Continued)

Time Relative to Peak sec	Wave Pressure, psi, at Indicated Elevation, ft										
	+22	+20	+18	+16	+14	+12	+10	+8	+1.0	-1.5	-4.0
	<u>swl = +8.6 ft; T = 14 sec; H = 12.0 ft</u>										
-0.500	0.25	0.00	0.75	0.25	1.00	0.75	0.50	2.50	4.25	4.00	4.00
-0.200	0.75	0.25	0.75	1.25	2.75	3.25	4.25	6.00	4.50	5.00	4.50
-0.100	0.50	0.25	4.00	6.25	5.25	4.25	5.50	6.00	4.50	4.75	4.25
-0.025	-6.00	8.00	8.50	7.75	6.75	5.50	5.50	6.50	4.25	4.50	3.75
Peak	-7.50	8.50	9.00	8.00	7.25	6.00	5.75	6.75	4.50	4.75	4.00
+0.025	0.25	8.25	8.50	7.50	7.25	6.25	6.00	6.25	4.75	4.75	4.25
+0.100	0.25	5.00	6.50	6.00	6.25	6.00	5.75	6.25	4.25	4.50	4.25
+0.200	0.75	3.75	5.50	5.00	5.75	5.50	5.50	6.25	4.00	4.00	3.75
+0.500	0.00	1.75	3.00	3.00	4.00	4.50	5.00	5.25	3.50	3.50	3.25
	<u>swl = +8.6 ft; T = 14 sec; H = 14.0 ft</u>										
-0.500	0.25	0.25	0.75	0.00	0.00	0.50	0.25	2.50	3.75	3.50	3.50
-0.200	0.50	0.25	0.50	0.00	2.25	3.00	4.25	5.75	5.00	5.25	5.50
-0.100	0.00	1.00	3.75	7.25	5.50	4.75	5.25	6.25	4.75	5.25	4.75
-0.025	0.50	8.00	10.00	8.75	7.25	6.25	6.25	6.75	5.00	5.00	4.50
Peak	2.00	9.75	9.50	8.75	7.50	6.75	6.50	7.75	5.00	5.25	4.75
+0.025	1.00	9.25	9.25	8.50	7.25	7.00	6.75	6.75	5.00	5.25	4.75
+0.100	0.00	7.25	8.00	8.25	7.50	7.00	7.00	7.50	5.00	5.25	5.00
+0.200	0.00	5.00	6.25	6.25	6.25	6.00	6.00	6.75	4.25	4.25	4.00
+0.500	-0.50	1.75	3.00	3.00	3.75	4.00	4.75	5.50	3.75	3.50	3.25

(Continued)

Table 8 (Concluded)

Time Relative to Peak sec	Wave Pressure, psi, at Indicated Elevation, ft										
	+22	+20	+18	+16	+14	+12	+10	+8	+1.0	-1.5	-4.0
-0.500	0.75	0.50	0.50	0.25	1.00	1.00	0.50	2.25	4.25	4.25	4.25
-0.200	0.75	0.50	0.00	0.00	1.25	3.00	5.25	7.25	6.00	6.25	6.00
-0.100	0.75	0.00	1.50	11.50	9.50	7.75	8.00	8.25	5.75	6.00	6.25
-0.025	1.50	17.75	17.25	15.50	12.75	10.75	9.75	9.75	6.25	6.50	6.00
Peak	0.50	18.50	17.75	15.75	13.25	11.25	10.00	9.75	6.00	6.50	6.25
+0.025	0.25	16.25	15.75	14.50	12.25	10.50	9.25	9.00	6.50	6.75	6.25
+0.100	0.50	9.00	9.50	9.25	8.75	8.00	7.75	7.75	5.50	5.75	5.50
+0.200	1.00	5.25	6.25	6.75	6.75	6.75	6.75	7.25	4.50	4.75	4.75
+0.500	0.50	2.25	3.25	3.50	4.75	5.25	5.50	5.75	4.50	4.50	4.25
$swl = +8.6 \text{ ft}; T = 14 \text{ sec}; H = 17.0 \text{ ft}$											
-0.500	0.00	0.00	0.00	0.00	0.00	0.00	0.00	0.00	3.25	2.75	2.75
-0.200	0.25	0.00	0.25	0.00	0.00	0.25	0.25	6.00	6.25	6.25	6.50
-0.100	0.50	0.25	0.75	0.50	2.00	5.50	9.25	12.25	7.25	7.75	7.75
-0.025	0.50	0.00	42.25	47.00	28.25	20.25	16.50	14.00	8.25	9.00	9.25
Peak	0.50	63.75	53.75	41.25	29.75	22.50	19.25	16.75	9.00	9.50	9.00
+0.025	-0.25	35.25	37.50	30.25	23.00	18.00	14.00	13.25	8.25	8.75	8.75
+0.100	0.75	6.25	14.00	13.50	11.50	12.00	10.50	11.00	7.25	7.25	6.75
+0.200	-0.25	-1.00	7.25	7.50	7.25	8.00	8.00	8.25	6.00	5.50	3.75
+0.500	0.25	0.00	3.50	3.75	4.25	5.00	5.50	6.50	4.25	4.25	4.00
$swl = +8.6 \text{ ft}; T = 14 \text{ sec}; H = 11.4 \text{ ft}$											
-0.500	0.00	0.00	0.00	0.00	0.00	0.00	0.00	0.00	3.25	2.75	2.75
-0.200	0.25	0.00	0.25	0.00	0.00	0.25	0.25	6.00	6.25	6.25	6.50
-0.100	0.50	0.25	0.75	0.50	2.00	5.50	9.25	12.25	7.25	7.75	7.75
-0.025	0.50	0.00	42.25	47.00	28.25	20.25	16.50	14.00	8.25	9.00	9.25
Peak	0.50	63.75	53.75	41.25	29.75	22.50	19.25	16.75	9.00	9.50	9.00
+0.025	-0.25	35.25	37.50	30.25	23.00	18.00	14.00	13.25	8.25	8.75	8.75
+0.100	0.75	6.25	14.00	13.50	11.50	12.00	10.50	11.00	7.25	7.25	6.75
+0.200	-0.25	-1.00	7.25	7.50	7.25	8.00	8.00	8.25	6.00	5.50	3.75
+0.500	0.25	0.00	3.50	3.75	4.25	5.00	5.50	6.50	4.25	4.25	4.00

Table 9

Instantaneous Wave Pressures on Modified Recurved Seawall, Plan R4S3

Time Relative to Peak sec	Wave Pressure, psi, at Indicated Elevation, ft							
	+21	+20	+18	+16	+14	+12	+10	+8
<u>swl = 8.6 ft; T = 12 sec; H = 12.0 ft</u>								
-0.500	0.75	0.25	0.75	1.00	1.50	1.00	2.25	4.50
-0.200	-0.25	1.50	2.25	3.50	3.00	3.25	3.50	5.25
-0.100	2.00	3.50	4.25	4.25	4.00	3.75	3.75	5.25
-0.025	4.50	4.50	4.75	4.50	4.25	4.00	4.25	5.25
Peak	5.00	4.50	4.50	4.50	4.25	4.00	4.50	5.25
+0.025	4.25	4.25	4.25	4.00	4.25	3.50	4.00	5.00
+0.100	3.00	3.50	3.25	3.75	4.00	3.75	4.00	5.00
+0.200	2.00	2.25	2.75	3.50	3.75	3.75	4.25	5.25
+0.500	0.50	1.00	2.00	2.75	3.75	4.00	4.50	5.25
<u>swl = 8.6 ft; T = 12 sec; H = 14.0 ft</u>								
-0.500	0.50	0.25	1.00	1.00	1.50	0.00	2.75	6.00
-0.200	-0.25	2.50	3.75	5.50	4.75	4.00	4.50	5.75
-0.100	2.75	5.50	5.00	5.50	5.25	4.25	4.75	5.75
-0.025	6.25	6.50	6.25	6.00	5.50	4.75	4.75	6.00
Peak	6.75	6.50	6.50	6.25	6.25	5.25	5.50	6.25
+0.025	6.25	6.50	6.25	6.00	6.00	5.00	5.25	6.00
+0.100	3.75	4.75	5.25	5.75	5.75	5.25	5.25	6.00
+0.200	2.25	3.25	4.25	4.75	5.50	5.25	5.50	6.00
+0.500	0.25	1.25	2.50	3.00	4.50	4.75	5.00	5.75
<u>swl = 8.6 ft; T = 12 sec; H = 16.8 ft</u>								
-0.500	0.50	1.25	1.00	0.75	0.25	2.25	1.25	1.50
-0.200	18.50	6.50	0.50	7.50	0.25	2.00	1.00	3.00
-0.100	0.75	3.00	7.50	16.50	11.50	10.25	7.50	8.25
-0.025	11.50	12.25	11.25	10.50	8.50	6.50	6.50	7.25
Peak	11.50	8.25	6.00	6.75	7.75	13.50	19.25	13.00
+0.025	6.50	7.50	14.75	17.75	13.25	12.75	11.25	9.75
+0.100	6.00	7.75	7.75	11.50	7.00	8.75	7.25	7.50
+0.200	2.25	3.75	5.00	5.50	5.75	5.50	6.00	6.50
+0.500	0.50	1.25	2.50	3.50	4.50	4.25	5.50	6.00

(Continued)

(Sheet 1 of 3)

Table 9 (Continued)

Time Relative to Peak sec	Wave Pressure, psi, at Indicated Elevation, ft							
	+21	+20	+18	+16	+14	+12	+10	+8
<u>swl = 8.6 ft; T = 12 sec; H = 16.0 ft</u>								
-0.500	-0.25	0.75	0.25	6.25	0.00	1.75	0.75	0.75
-0.200	0.00	3.00	0.75	6.25	0.00	1.75	0.75	0.75
-0.100	1.00	0.00	8.75	6.00	1.75	5.75	9.25	10.00
-0.025	22.25	18.25	22.50	19.25	12.75	9.00	9.50	9.00
Peak	21.50	13.25	8.75	9.00	9.00	25.25	33.00	26.00
+0.025	10.75	9.75	28.75	27.00	21.75	20.00	17.25	14.75
+0.100	7.00	8.75	7.75	7.75	7.75	9.75	9.00	9.00
+0.200	3.75	4.00	5.25	5.50	6.25	5.75	6.50	7.25
+0.500	0.50	1.00	2.50	3.00	4.50	4.50	5.25	5.75
<u>swl = 8.6 ft; T = 14 sec; H = 12.0 sec</u>								
-0.500	-0.50	0.00	0.75	1.25	2.00	0.75	-0.25	-0.75
-0.200	0.25	1.75	3.00	4.25	6.75	0.75	0.25	0.00
-0.100	4.00	6.75	0.00	0.00	4.00	5.00	4.75	3.75
-0.025	5.50	6.75	7.25	1.00	9.25	7.25	6.50	5.25
Peak	11.00	9.00	8.50	7.50	7.00	6.00	6.00	6.50
+0.025	7.00	6.25	6.25	6.50	7.50	9.50	0.25	6.50
+0.100	4.25	5.00	5.50	6.00	7.00	4.25	0.25	3.75
+0.200	4.25	6.75	2.25	0.75	2.75	2.75	3.00	3.50
+0.500	3.00	5.75	0.50	0.50	1.00	0.50	1.00	1.25
<u>swl = 8.6 ft; T = 14 sec; H = 14.0 ft</u>								
-0.500	-0.25	1.00	0.75	1.50	1.00	0.75	1.50	-1.00
-0.200	-0.50	3.25	2.75	4.75	5.75	0.50	1.75	-1.25
-0.100	4.75	7.00	3.00	3.00	2.75	4.25	5.00	5.00
-0.025	6.25	7.75	6.75	5.25	11.00	9.00	7.75	7.50
Peak	14.00	11.75	10.25	9.25	8.50	6.75	6.50	7.00
+0.025	8.75	9.50	7.50	7.75	7.75	13.00	5.75	8.50
+0.100	5.25	8.00	7.00	7.50	7.50	5.25	3.50	4.50
+0.200	5.75	7.00	3.25	3.50	3.50	4.50	4.25	5.50
+0.500	3.75	6.00	0.75	2.75	0.50	1.25	1.75	3.00

(Continued)

(Sheet 2 of 3)

Table 9 (Concluded)

Time Relative to Peak sec	Wave Pressure, psi, at Indicated Elevation, ft							
	+21	+20	+18	+16	+14	+12	+10	+8
<u>swl = 8.6 ft; T = 14 sec; H = 17.0 ft</u>								
-0.500	0.00	1.00	0.75	1.25	0.50	0.50	2.50	-0.25
-0.200	-0.50	5.50	3.00	5.00	6.75	0.50	2.00	-0.50
-0.100	5.75	8.50	1.50	5.75	2.25	6.25	8.00	7.50
-0.025	8.00	9.25	8.25	15.75	14.50	12.25	11.00	10.25
Peak	21.00	17.25	14.75	13.50	11.75	9.25	8.75	8.50
+0.025	13.75	13.25	10.25	10.25	9.50	19.25	16.50	14.50
+0.100	7.25	10.25	9.00	9.25	9.25	9.00	8.50	7.50
+0.200	5.75	7.00	3.25	6.25	3.25	4.00	4.50	6.50
+0.500	3.75	6.00	1.00	5.50	0.25	1.00	1.75	3.75
<u>swl = 8.6 ft; T = 14 sec; H = 11.4 ft</u>								
-0.500	1.00	1.50	1.25	6.00	-0.50	0.50	0.00	1.25
-0.200	0.25	1.50	0.75	5.25	7.25	0.25	4.75	-0.50
-0.100	6.75	9.75	1.25	6.50	4.50	4.75	12.50	8.25
-0.025	11.00	11.25	8.75	28.25	17.00	16.50	14.75	13.75
Peak	31.75	24.50	21.75	20.25	17.50	14.25	13.25	13.00
+0.025	27.50	22.75	17.75	16.00	14.25	38.50	35.00	28.75
+0.100	9.25	12.50	10.75	11.00	10.00	9.75	12.75	7.75
+0.200	7.00	8.75	4.00	8.50	3.50	5.00	4.75	7.00
+0.500	4.75	6.75	1.00	7.75	0.75	1.50	2.00	4.25

Table 10

Peak Pressures on Modified Recurved Seawall, Plan R4S3

Wave No.	Peak Pressure, psi, at Indicated Elevation, ft							
	+21	+20	+18	+16	+14	+12	+10	+8
<u>swl = 8.6 ft; T = 12 sec; H = 16.8 ft</u>								
1	11.75	12.25	11.00	10.25	7.75	6.50	7.00	7.25
2	15.50	13.50	12.00	12.25	8.75	9.75	10.50	12.00
3	17.25	12.75	11.75	11.25	8.50	32.75	12.50	9.00
4	23.25	17.75	15.75	20.50	15.25	22.25	18.25	14.75
5	28.75	20.50	17.25	24.00	16.75	25.25	12.50	10.50
6	24.75	17.50	14.25	15.25	18.00	48.50	14.50	11.00
7	30.75	24.25	20.00	35.25	16.00	16.50	13.75	12.00
8	28.75	19.75	17.50	22.75	29.00	17.50	10.25	9.75
9	16.25	13.75	11.50	10.75	8.00	6.50	6.50	8.50
10	15.75	14.75	12.25	11.00	9.00	7.50	9.25	9.00
11	13.00	13.75	11.00	10.00	9.25	7.50	29.75	12.75
12	19.25	14.50	12.75	16.00	13.75	19.75	10.50	9.75
13	31.00	20.25	18.00	17.25	13.75	11.00	9.00	7.00
14	20.75	21.50	15.25	24.00	25.50	17.25	17.25	14.25
15	27.00	15.25	17.75	13.50	11.75	29.00	11.75	10.50
16	20.00	16.50	26.75	20.25	19.25	14.25	9.00	8.50
17	13.75	13.50	12.00	10.50	8.75	6.75	6.75	7.75
18	17.00	14.75	12.25	11.00	9.50	7.00	9.25	8.75
19	15.25	12.50	11.50	11.75	10.25	11.50	10.75	8.75
20	20.50	15.75	12.00	11.75	14.75	7.75	13.00	12.75
21	28.25	24.00	22.25	22.75	17.50	12.75	9.50	9.00
22	17.50	15.50	15.00	15.75	11.25	22.75	13.75	10.50
23	32.50	21.00	24.00	31.25	44.25	44.25	26.75	16.25
24	25.00	18.50	14.50	17.00	13.00	10.50	9.50	8.25
25	16.25	13.75	11.75	11.25	8.50	6.75	6.50	7.50
26	20.00	14.50	12.00	11.00	9.25	7.00	7.00	7.25
27	15.50	14.00	12.25	16.50	9.00	9.25	21.00	15.75
28	20.00	17.75	12.50	12.00	10.00	7.75	7.50	9.50
29	27.00	18.75	15.75	16.25	13.00	17.00	13.00	10.50
30	27.75	20.00	18.25	15.25	21.75	12.50	9.00	9.00
31	37.00	21.75	24.75	38.00	17.25	9.25	8.25	8.50
32	33.00	19.25	16.50	15.25	16.50	11.25	11.75	10.00
33	17.75	15.25	13.00	11.75	9.00	6.75	7.25	7.25
34	21.50	16.50	13.75	12.50	9.75	9.50	7.75	8.00
35	26.00	17.25	14.25	13.25	13.75	9.75	10.25	9.50
36	23.00	17.50	31.75	22.25	15.50	12.50	12.75	9.50
37	23.00	17.75	15.75	39.25	25.25	28.50	16.50	12.00
38	19.00	19.50	24.25	30.50	20.75	20.50	12.25	10.25
39	52.25	29.75	24.50	28.00	29.25	13.00	11.00	9.75
40	34.75	19.50	21.25	22.50	19.00	17.25	11.50	10.25
41	13.75	12.75	11.50	10.50	8.00	6.75	6.50	6.75
42	19.00	14.25	12.50	15.50	11.50	13.75	8.50	9.25
43	14.75	12.75	12.50	13.00	12.00	14.75	19.75	15.75

(Continued)

(Sheet 1 of 10)

Table 10 (Continued)

Wave No.	Peak Pressure, psi, at Indicated Elevation, ft							
	+21	+20	+18	+16	+14	+12	+10	+8
<u>swl = 8.6 ft; T = 12 sec; H = 16.8 ft (Continued)</u>								
44	17.00	14.00	12.50	11.25	10.50	15.50	7.50	8.00
45	41.75	29.50	23.00	18.75	27.00	11.25	10.25	9.25
46	21.00	14.50	19.50	14.00	14.00	18.25	23.25	12.25
47	26.50	19.25	16.00	34.50	20.25	9.00	8.50	8.25
48	22.75	36.25	19.25	23.25	16.75	11.00	8.50	9.00
49	16.25	13.50	12.00	12.00	8.25	6.75	7.25	8.25
50	18.00	14.75	12.25	12.25	9.50	17.25	7.50	9.00
51	15.75	14.00	11.50	12.00	9.00	11.00	21.00	11.25
52	21.00	15.25	12.50	11.75	10.50	16.25	16.50	10.75
53	32.00	17.25	18.00	16.50	15.25	10.75	8.00	8.50
54	21.50	15.00	14.00	20.50	14.75	10.75	10.50	9.50
55	47.00	29.75	23.00	28.75	29.50	16.75	11.50	10.00
56	29.75	20.50	18.75	34.50	22.25	10.00	9.75	9.00
57	14.75	13.00	11.50	10.75	8.25	6.50	6.25	8.00
58	19.00	15.25	12.50	14.00	9.00	7.00	7.00	7.50
59	17.00	14.25	11.75	12.25	11.25	21.25	25.75	9.00
60	20.25	19.00	26.25	14.25	11.00	15.25	12.50	11.00
61	33.50	23.00	18.75	49.25	25.00	14.00	9.25	9.25
62	23.00	19.75	18.75	16.50	11.75	8.75	7.50	7.75
63	43.50	27.00	22.50	34.50	22.50	11.25	9.75	9.25
64	25.00	18.00	16.25	16.00	19.50	13.25	8.75	8.50
65	17.25	14.00	12.25	10.75	8.75	6.75	6.75	7.25
66	15.50	14.00	12.00	12.50	9.00	10.75	8.50	9.00
67	21.00	15.75	12.25	14.00	12.00	10.25	11.75	11.25
68	20.00	17.50	15.50	20.00	13.50	14.00	9.00	7.75
69	29.00	19.25	16.00	28.75	38.25	12.50	9.00	8.50
70	19.50	18.50	17.25	15.25	15.00	14.25	9.00	9.00
71	32.25	22.50	18.50	32.25	32.25	13.00	9.50	9.00
72	36.00	23.75	68.25	39.50	27.00	10.00	9.25	9.50
73	15.50	14.50	12.75	11.25	9.50	7.25	6.75	7.25
74	19.75	15.25	12.75	12.25	9.50	11.00	8.00	8.50
75	15.75	13.00	11.75	11.50	8.25	16.50	20.25	12.25
76	18.75	20.50	15.75	11.75	11.50	19.50	10.75	9.50
77	31.75	20.00	17.00	17.75	14.25	13.75	9.00	8.25
78	27.50	18.75	16.50	16.00	15.50	11.75	9.75	9.50
79	38.00	22.25	21.75	34.25	43.50	11.75	0.50	9.25
80	31.25	23.00	18.00	51.00	25.50	9.75	8.25	8.50
81	16.25	15.00	11.75	10.75	9.25	7.00	6.50	7.00
82	16.00	13.50	12.00	10.50	9.25	23.50	10.75	9.00
83	18.75	15.00	12.50	12.00	9.75	12.25	10.25	9.25
84	20.25	13.75	12.75	12.50	9.25	7.50	9.25	9.50
85	27.00	20.00	15.00	16.25	17.00	18.75	10.00	8.75
86	23.50	17.00	14.50	28.50	60.75	68.00	17.00	12.00
87	35.75	24.25	19.75	17.25	13.25	10.25	9.25	8.75
88	35.25	23.25	19.50	20.75	16.25	10.00	8.50	8.75

(Continued)

(Sheet 2 of 10)

Table 10 (Continued)

Wave No.	Peak Pressure, psi, at Indicated Elevation, ft							
	+21	+20	+18	+16	+14	+12	+10	+8
<u>swl = 8.6 ft; T = 12 sec; H = 16.8 ft (Continued)</u>								
89	17.00	13.50	11.50	10.75	8.50	7.25	6.75	7.00
90	22.00	15.75	12.50	13.50	9.00	7.25	7.25	8.25
91	15.50	15.25	12.25	10.25	8.75	9.75	24.25	10.00
92	20.75	18.75	18.25	15.00	12.25	14.00	15.50	11.00
93	32.50	21.25	18.50	35.75	24.75	12.75	9.75	8.75
94	22.50	16.75	14.75	15.00	13.00	15.00	16.75	10.50
95	43.00	27.50	23.00	27.50	17.75	11.50	10.25	9.25
96	30.00	20.25	17.25	20.00	15.25	12.50	8.00	8.75
97	15.75	14.25	12.00	11.50	9.25	7.00	6.50	7.25
98	20.00	15.00	12.75	12.50	9.25	7.50	7.25	7.75
99	19.25	16.00	14.50	13.50	9.25	12.25	16.75	12.00
100	19.75	16.00	12.75	15.00	14.50	14.25	16.50	10.25
Min	11.75	12.25	11.00	10.00	7.75	6.50	6.25	6.75
Max	52.25	36.25	68.25	51.00	60.75	68.00	29.75	16.25
Mean	23.60	17.84	16.34	18.46	15.53	13.92	11.25	9.56
Std. Dev.	8.14	4.44	6.76	9.07	8.83	8.93	4.85	1.92

swl = 8.6 ft; T = 12 sec; H = 16.0 ft

1	19.50	16.25	13.25	12.75	10.00	8.00	7.75	8.75
2	21.75	17.50	15.25	13.25	11.50	15.00	35.25	16.50
3	28.50	17.75	15.75	16.50	14.75	14.00	9.25	9.75
4	20.25	16.00	13.50	16.50	28.25	15.50	13.25	12.25
5	55.75	33.75	29.50	28.50	29.00	16.25	11.50	12.00
6	36.75	27.75	21.75	21.00	17.25	13.25	13.25	13.25
7	50.75	30.25	24.00	23.00	22.00	21.50	10.75	10.25
8	40.75	26.75	21.50	21.75	17.75	16.25	11.00	11.75
9	19.75	17.00	14.50	12.25	10.50	8.25	7.50	7.75
10	23.50	17.75	14.50	16.25	11.00	8.75	8.00	8.25
11	21.50	17.25	14.00	14.25	15.50	10.75	14.50	9.50
12	32.50	19.50	15.75	16.75	15.50	27.00	20.75	13.75
13	38.50	26.00	21.50	21.75	19.00	25.00	15.50	11.25
14	30.50	20.50	23.00	16.50	16.50	15.75	16.25	12.75
15	49.00	32.00	30.50	45.25	25.25	12.75	11.25	10.50
16	53.00	25.75	25.50	23.50	25.00	17.00	11.00	10.25
17	21.00	15.75	13.25	14.00	9.75	8.00	7.50	13.00
18	20.25	15.25	13.75	14.25	10.50	17.50	12.00	13.00
19	19.75	17.25	14.75	16.25	11.75	9.00	10.50	9.00
20	27.00	22.25	24.00	20.50	21.25	14.50	18.75	16.00
21	41.00	29.00	32.25	32.75	23.00	42.00	14.75	10.25
22	24.50	17.50	18.25	17.00	16.50	25.25	11.50	9.75
23	33.00	24.50	19.00	18.00	44.50	12.75	11.00	9.75

(Continued)

(Sheet 3 of 10)

Table 10 (Continued)

Wave No.	Peak Pressure, psi, at Indicated Elevation, ft							
	+21	+20	+18	+16	+14	+12	+10	+8
<u>swl = 8.6 ft; T = 12 sec; H = 16.0 ft (Continued)</u>								
24	32.25	25.00	19.75	28.00	44.25	31.25	20.75	17.75
25	20.00	16.75	14.25	13.25	11.00	8.50	7.50	8.00
26	20.00	15.25	13.25	15.75	10.75	14.50	8.25	8.25
27	22.50	19.75	15.25	15.75	11.25	19.75	29.75	13.50
28	23.50	21.25	13.25	13.75	14.75	14.00	15.00	15.50
29	49.50	30.50	26.00	33.00	21.00	19.50	11.25	10.25
30	29.25	29.50	24.00	19.75	18.25	15.25	11.50	10.00
31	25.00	20.00	16.75	21.00	24.75	32.50	10.25	8.50
32	20.00	15.00	12.75	11.25	9.25	7.50	7.00	8.00
33	22.00	16.75	14.50	14.50	10.50	13.75	8.25	9.00
34	27.00	21.50	13.75	15.75	11.75	13.75	13.25	11.25
35	24.25	25.00	25.50	22.75	19.75	26.75	22.00	12.50
36	42.75	28.00	24.00	60.50	33.75	15.50	11.25	9.50
37	32.75	22.75	19.00	16.25	12.50	21.75	10.00	9.75
38	40.25	28.25	25.50	155.25	31.25	11.50	10.25	9.75
39	31.25	22.00	19.00	19.00	26.00	31.00	15.25	12.25
40	20.00	16.75	13.75	12.25	10.50	8.50	7.50	8.25
41	26.75	20.00	16.75	15.75	11.25	9.25	8.25	8.25
42	25.25	18.50	15.00	16.00	11.75	27.25	13.00	10.50
43	18.75	20.75	18.00	22.75	17.00	27.75	23.75	19.25
44	53.75	31.50	26.25	23.25	17.25	12.25	10.25	9.75
45	34.50	27.00	24.75	21.25	37.75	85.75	17.50	12.50
46	54.50	34.00	27.00	43.00	26.25	16.25	13.25	11.00
47	29.00	24.50	25.00	23.50	17.50	12.00	10.25	10.00
48	22.75	17.50	15.25	13.00	11.75	8.75	8.00	8.00
49	25.25	18.25	15.00	15.50	11.25	8.75	7.75	9.25
50	18.25	14.75	12.00	12.50	10.75	10.50	7.25	8.00
51	28.00	19.50	17.75	13.75	12.50	9.25	8.00	8.00
52	32.75	21.25	18.00	16.75	13.75	11.50	9.50	9.25
53	41.50	27.50	23.50	24.75	19.75	12.25	11.25	10.25
54	34.00	23.25	19.25	26.25	17.25	9.75	9.00	8.25
55	45.25	25.25	20.25	20.25	20.00	12.25	11.00	9.50
56	20.25	19.50	15.00	12.75	11.00	8.50	7.50	8.00
57	23.00	18.00	15.00	14.25	11.00	8.25	7.75	8.50
58	23.00	18.00	16.75	13.75	12.00	10.75	21.75	14.75
59	30.50	19.50	16.50	16.50	17.00	12.25	13.00	11.25
60	54.00	30.00	26.75	31.00	20.50	12.50	11.00	10.00
61	33.75	26.75	27.50	25.25	17.25	13.25	9.75	9.00
62	51.25	31.50	33.50	64.25	23.00	12.75	10.75	10.25
63	35.75	25.75	23.00	21.50	18.00	15.75	17.25	10.75
64	19.75	16.75	14.50	12.50	10.25	8.00	7.25	8.00
65	25.50	19.00	16.25	15.00	11.25	8.75	7.75	8.25
66	21.50	16.75	16.00	19.75	15.25	26.50	10.25	9.75
67	30.50	20.00	18.50	23.25	29.25	27.00	17.25	12.00
68	38.75	24.50	67.00	33.25	25.25	11.25	10.25	10.00

(Continued)

(Sheet 4 of 10)

Table 10 (Continued)

Wave No.	Peak Pressure, psi, at Indicated Elevation, ft							
	+21	+20	+18	+16	+14	+12	+10	+8
<u>swl = 8.6 ft; T = 12 sec; H = 16.0 ft (Continued)</u>								
69	39.25	25.75	23.00	26.00	34.25	26.25	13.75	12.00
70	34.50	24.25	20.25	19.75	38.25	11.00	9.25	9.25
71	31.75	22.50	18.25	25.00	36.50	12.75	8.75	8.00
72	19.25	15.75	13.50	13.75	10.50	8.25	7.50	8.00
73	24.00	19.00	15.25	14.25	11.25	8.50	8.50	8.75
74	21.25	17.00	14.50	14.00	10.50	39.00	14.50	11.50
75	31.25	23.00	20.75	18.50	30.50	23.75	15.25	9.00
76	50.25	36.75	28.00	26.00	33.25	18.25	12.25	10.50
77	48.25	37.25	29.00	23.00	21.25	15.75	16.25	11.00
78	46.25	29.75	25.00	53.00	25.25	11.50	10.25	10.75
79	39.00	25.75	25.50	31.75	14.75	11.75	9.25	8.75
80	19.25	33.50	15.00	13.00	10.50	8.25	7.50	8.25
81	25.25	40.50	16.75	15.00	12.00	9.25	8.25	8.25
82	23.25	33.75	19.00	23.25	12.75	13.00	10.50	10.75
83	28.50	31.75	16.75	19.25	18.25	21.00	22.25	14.75
84	36.00	53.75	24.50	18.25	21.25	25.75	15.75	13.00
85	33.75	61.75	22.25	28.25	16.25	14.75	15.00	11.50
86	36.00	51.00	22.00	35.25	37.50	11.75	10.25	9.75
87	31.75	42.00	17.50	15.75	28.00	21.50	11.50	9.75
88	21.75	17.00	15.25	13.50	11.25	8.50	7.75	8.75
89	23.25	18.75	16.00	16.00	11.00	9.00	7.75	8.00
90	26.75	19.00	15.50	17.25	25.00	13.50	8.00	8.25
91	30.00	32.25	18.75	20.00	17.00	13.00	9.25	10.00
92	28.50	20.00	20.50	31.00	27.50	14.75	8.50	9.00
93	30.00	21.75	19.25	16.75	11.75	11.50	9.00	10.50
94	35.75	24.25	20.25	21.50	14.25	10.50	9.75	9.00
95	34.50	22.75	18.00	16.50	28.75	23.25	12.75	10.50
96	17.25	16.25	14.25	13.00	10.50	8.50	7.75	7.25
97	23.75	18.00	15.00	13.25	10.75	8.25	8.00	8.75
98	23.50	17.50	14.50	13.00	15.50	16.25	8.50	8.50
99	23.75	18.50	17.50	18.00	15.75	22.75	16.00	12.00
100	37.25	24.25	24.00	41.25	21.75	11.00	10.25	9.75
Min	17.25	14.75	12.00	11.25	9.75	7.50	7.00	7.25
Max	55.75	61.75	67.00	155.25	44.50	85.75	35.25	19.25
Mean	30.84	24.02	19.75	22.36	18.68	16.11	11.91	10.37
Std. Dev.	10.05	8.30	6.89	16.49	8.41	10.05	4.86	2.27

swl = 8.6 ft; T = 14 sec; H = 17.0 ft

1	25.25	17.50	16.50	14.00	12.00	9.50	8.50	9.00
2	18.75	15.75	13.50	12.00	10.75	8.25	8.25	7.75
3	16.25	14.75	13.00	12.50	10.50	9.25	12.50	8.00

(Continued)

(Sheet 5 of 10)

Table 10 (Continued)

Wave No.	Peak Pressure, psi, at Indicated Elevation, ft							
	+21	+20	+18	+16	+14	+12	+10	+8
<u>swl = 8.6 ft; T = 14 sec; H = 17.0 ft (Continued)</u>								
4	22.25	17.50	15.00	12.75	11.00	9.25	8.25	8.25
5	20.00	16.00	14.50	13.25	11.00	9.50	8.50	8.75
6	16.75	14.00	11.75	11.00	10.25	11.25	7.25	8.00
7	15.50	12.75	11.75	10.50	9.00	7.75	7.25	7.75
8	20.25	15.75	14.25	13.00	11.00	9.25	8.75	8.75
9	17.75	15.00	14.00	12.75	11.25	9.50	14.50	8.50
10	25.00	19.75	17.75	16.25	13.00	43.50	16.00	10.50
11	23.00	18.00	15.25	14.00	12.25	10.25	9.00	9.00
12	33.00	22.25	18.50	16.00	13.50	10.50	9.75	9.25
13	17.75	14.75	13.75	12.50	11.25	9.00	8.75	8.50
14	15.25	13.25	12.00	11.00	9.75	42.50	15.50	9.00
15	24.50	17.75	16.50	14.50	12.50	9.75	9.00	9.50
16	22.25	17.75	15.50	13.50	12.25	9.50	8.75	8.50
17	21.50	18.00	16.00	14.25	12.25	9.75	15.50	9.00
18	27.50	20.00	17.00	14.25	12.25	10.00	9.00	9.00
19	24.50	19.50	17.50	15.25	12.75	10.75	9.50	9.25
20	16.50	13.50	12.50	11.50	10.50	8.25	8.00	8.50
21	20.25	15.75	13.75	12.00	10.25	8.75	7.75	8.00
22	22.75	17.75	15.75	13.50	11.50	9.00	8.75	8.50
23	20.00	17.25	14.75	13.25	11.00	9.00	9.50	8.25
24	20.25	16.25	14.75	13.00	11.00	9.00	9.75	10.00
25	22.50	19.00	17.00	15.00	12.25	9.75	9.25	8.50
26	26.50	19.75	17.00	15.50	12.25	10.50	9.75	9.25
27	20.75	15.75	13.75	12.00	10.75	8.25	8.50	8.75
28	15.75	13.00	11.50	10.50	9.25	8.75	10.75	8.00
29	24.50	17.75	15.75	13.50	11.75	9.25	8.50	8.25
30	21.75	17.50	15.75	14.25	12.00	9.75	8.75	8.75
31	18.00	15.75	14.75	13.50	11.50	9.00	15.50	8.75
32	23.25	18.00	16.25	15.00	12.75	10.00	9.50	9.25
33	23.75	17.00	15.25	14.00	11.75	9.50	9.25	9.50
34	18.75	14.75	13.25	12.00	10.25	9.00	8.50	8.75
35	17.00	13.75	12.25	11.00	9.25	8.00	19.00	8.25
36	24.00	18.00	15.25	13.75	12.00	9.25	8.75	9.00
37	19.50	16.25	14.50	13.00	11.50	9.25	9.75	8.75
38	18.50	16.00	15.25	13.25	11.75	14.25	9.00	9.75
39	23.75	18.50	15.75	13.75	12.00	10.00	9.50	9.00
40	23.00	18.00	15.25	13.75	11.75	9.75	9.25	8.50
41	15.75	13.25	11.50	11.00	9.75	12.00	8.50	9.00
42	16.50	14.50	13.00	11.50	10.25	8.25	14.25	7.75
43	29.75	21.25	17.75	15.25	12.50	9.75	9.25	9.25
44	20.00	16.75	14.25	13.00	11.25	9.00	8.25	8.00
45	19.50	16.25	14.75	13.00	11.50	8.75	8.50	7.75
46	20.00	16.50	14.00	12.00	10.75	8.75	8.50	8.75
47	21.75	17.00	14.75	12.75	11.25	8.75	9.00	8.25
48	13.75	12.00	11.25	10.75	9.50	8.25	8.00	7.75

(Continued)

(Sheet 6 of 10)

Table 10 (Continued)

Wave No.	Peak Pressure, psi, at Indicated Elevation, ft							
	+21	+20	+18	+16	+14	+12	+10	+8
<u>swl = 8.6 ft; T = 14 sec; H = 17.0 ft (Continued)</u>								
49	18.00	14.75	13.00	11.50	10.00	8.00	7.50	8.00
50	31.25	22.00	18.25	15.50	12.75	9.75	8.75	8.75
51	24.75	19.25	17.25	15.00	12.50	10.00	9.00	9.25
52	18.75	15.75	14.00	13.00	11.25	27.75	14.25	9.00
53	28.00	21.00	17.00	14.25	12.00	9.25	8.50	8.75
54	22.00	17.75	15.25	14.00	11.75	9.75	9.25	8.75
55	17.25	13.75	12.00	11.00	9.75	8.75	8.25	7.75
56	17.75	14.25	12.25	10.50	8.75	7.50	13.50	7.50
57	24.75	19.00	16.00	14.25	11.50	9.00	8.75	8.25
58	20.25	16.00	14.25	12.75	11.00	8.75	8.50	8.50
59	19.00	15.50	14.00	12.50	10.00	8.75	8.25	8.25
60	27.00	19.75	17.00	14.75	12.75	10.00	9.25	8.75
61	27.25	21.25	18.25	15.50	12.50	9.75	9.75	9.25
62	17.25	14.25	13.00	12.00	10.50	9.00	8.75	7.75
63	18.25	14.75	13.25	11.50	10.00	8.00	8.00	8.25
64	29.00	19.50	16.75	14.75	12.25	9.75	8.75	9.25
65	21.25	16.75	13.75	12.50	10.50	9.00	8.00	8.75
66	21.00	17.50	16.25	14.00	11.50	9.25	8.75	8.50
67	24.25	17.25	15.25	13.75	11.75	10.00	9.00	8.50
68	19.75	15.75	14.00	12.50	11.00	9.75	9.00	8.50
69	16.25	13.00	11.75	11.00	10.00	8.50	7.75	7.50
70	15.00	12.25	11.25	10.50	9.00	8.00	10.75	7.00
71	20.00	15.50	14.00	12.75	10.75	8.50	8.50	8.50
72	22.25	18.50	16.25	14.50	12.25	10.00	9.25	8.75
73	20.00	17.00	15.50	14.00	12.00	9.75	9.00	8.00
74	31.75	22.75	19.00	16.00	13.00	10.25	10.00	9.25
75	29.50	21.50	18.50	16.25	13.50	10.50	9.75	9.00
76	17.25	14.75	13.50	12.50	10.50	8.25	8.50	8.00
77	15.75	12.75	11.50	10.75	9.25	8.00	7.75	7.75
78	28.25	20.75	17.75	15.75	12.50	10.00	9.25	9.00
79	22.25	17.75	16.00	14.50	12.25	10.00	9.75	8.75
80	17.25	14.75	13.25	12.75	11.00	9.25	9.75	9.00
81	28.00	20.25	16.25	14.25	12.50	9.75	8.75	11.00
82	24.25	18.25	16.00	14.50	12.25	9.75	9.25	9.75
83	19.00	15.50	14.25	12.50	10.75	8.75	9.00	8.50
84	17.00	13.25	12.50	11.00	9.75	7.50	7.50	8.00
85	38.00	22.25	18.00	15.50	12.75	10.00	9.75	9.00
86	22.00	18.75	17.25	15.50	13.25	11.00	9.75	9.00
87	31.25	22.75	18.00	15.50	13.75	11.00	10.75	9.25
88	25.00	19.50	17.25	15.50	13.25	10.75	10.00	9.50
89	18.00	14.75	12.75	11.50	10.25	9.25	8.25	7.75
90	17.50	14.50	12.75	11.50	9.50	8.25	7.50	7.75
91	28.00	19.75	16.50	14.25	12.25	10.00	9.25	9.50
92	21.75	17.50	14.00	12.75	11.25	9.75	9.25	9.00
93	16.50	14.75	13.00	12.25	10.25	11.50	9.50	8.50

(Continued)

(Sheet 7 of 10)

Table 10 (Continued)

Wave No.	Peak Pressure, psi, at Indicated Elevation, ft							
	+21	+20	+18	+16	+14	+12	+10	+8
<u>swl = 8.6 ft; T = 14 sec; H = 17.0 ft (Continued)</u>								
94	24.00	19.25	16.75	15.50	13.50	10.50	10.25	8.25
95	23.50	17.75	15.50	14.25	12.50	10.25	10.00	9.25
96	14.25	12.50	12.25	11.25	10.00	8.00	7.75	8.25
97	16.50	14.00	12.75	11.25	9.50	8.50	8.00	7.50
98	27.00	19.50	16.25	14.50	12.50	10.00	10.00	8.75
99	28.50	21.75	18.25	15.50	13.00	10.00	9.25	9.00
100	21.50	18.00	16.75	15.25	13.00	10.25	9.75	8.50
Min	13.75	12.00	11.25	10.50	8.75	7.50	7.25	7.00
Max	38.00	22.75	19.00	16.25	13.75	43.50	19.00	11.00
Mean	21.69	16.98	14.91	13.30	11.38	10.28	9.53	8.64
Std. Dev.	4.69	2.64	2.00	1.59	1.20	5.12	2.05	0.65

swl = 8.6 ft; T = 14 sec; H = 11.4 ft

1	43.50	29.50	24.50	21.75	18.00	14.50	13.00	11.50
2	51.25	34.75	29.50	26.00	21.75	18.25	16.25	14.75
3	72.25	48.25	39.75	34.25	27.50	21.25	18.50	15.75
4	137.50	66.25	50.00	40.25	31.25	23.00	19.00	16.50
5	58.25	46.75	36.00	30.25	26.00	19.50	17.25	15.50
6	37.25	27.75	23.25	20.75	17.00	13.25	12.25	11.50
7	74.50	39.25	30.50	25.75	20.25	15.75	14.75	13.00
8	51.50	32.75	27.50	24.25	20.25	16.00	14.25	12.50
9	41.25	29.00	25.25	22.50	19.25	15.25	14.25	12.75
10	105.00	61.75	46.25	38.25	31.50	23.50	20.00	16.75
11	106.75	82.50	63.25	49.75	36.50	27.25	23.25	19.00
12	56.00	40.25	33.75	30.00	24.75	19.25	17.00	14.50
13	27.75	23.50	21.25	19.00	16.75	13.50	12.75	11.75
14	59.50	60.75	42.25	31.25	25.25	19.50	16.75	15.00
15	44.00	31.00	26.50	23.25	20.25	16.00	14.25	13.00
16	51.25	38.50	33.00	28.25	23.25	18.00	16.25	14.50
17	107.75	60.25	51.00	43.00	35.25	26.25	22.00	18.00
18	131.75	60.50	57.25	42.25	31.00	24.00	21.00	18.00
19	67.00	47.75	40.75	34.75	28.25	21.50	18.75	15.75
20	28.75	23.75	21.25	18.75	15.75	12.50	11.00	10.25
21	40.75	29.00	25.50	21.25	17.75	14.75	13.25	11.75
22	36.25	26.00	23.50	20.75	17.25	13.00	12.00	11.50
23	29.75	27.00	25.00	22.75	19.25	15.25	15.75	13.25
24	75.75	46.25	38.50	32.75	26.25	20.50	17.75	15.50
25	129.50	116.25	96.25	58.00	45.00	33.75	25.75	21.25
26	71.25	46.00	39.50	50.00	28.50	21.25	19.00	16.00
27	33.75	24.75	21.75	19.25	16.50	13.25	12.00	11.50
28	47.75	33.75	27.25	23.00	18.75	14.75	13.25	12.25

(Continued)

(Sheet 8 of 10)

Table 10 (Continued)

Wave No.	Peak Pressure, psi, at Indicated Elevation, ft							
	+21	+20	+18	+16	+14	+12	+10	+8
<u>swl = 8.6 ft; T = 14 sec; H = 11.4 ft (Continued)</u>								
29	35.75	26.25	23.50	21.50	18.50	14.75	13.25	12.25
30	34.50	26.50	24.00	22.00	19.00	15.00	14.00	12.50
31	96.25	53.50	42.75	36.00	29.50	21.75	19.00	16.25
32	58.75	68.25	48.25	38.75	31.50	24.25	20.25	17.00
33	55.00	40.75	36.50	34.00	26.25	19.75	16.75	14.50
34	26.50	21.00	19.00	17.50	15.00	12.25	11.00	11.00
35	28.50	21.75	18.75	16.25	14.00	10.75	10.50	9.75
36	36.75	28.25	23.75	21.25	18.25	14.50	13.25	12.00
37	53.00	38.50	33.50	29.50	24.75	19.00	16.50	14.50
38	100.25	52.25	40.50	34.25	26.75	20.25	17.00	14.75
39	65.25	51.50	50.25	37.50	26.25	18.25	15.00	13.50
40	59.25	52.25	35.75	29.00	22.75	16.75	15.25	13.75
41	22.50	19.00	16.25	15.00	13.00	10.50	9.75	9.50
42	39.00	27.75	23.25	20.25	16.25	12.50	11.50	11.00
43	37.75	27.25	22.75	20.00	17.25	13.75	13.00	12.00
44	44.00	30.25	26.25	23.50	20.25	16.00	15.25	13.50
45	81.75	58.25	50.25	43.25	34.75	26.00	21.50	17.25
46	143.00	64.75	115.25	53.25	31.75	24.25	20.50	16.25
47	64.50	43.50	32.75	29.00	23.25	20.00	17.00	14.25
48	30.00	23.75	21.50	19.50	17.00	13.25	12.25	11.25
49	36.75	26.75	22.50	20.00	17.00	13.50	12.25	11.25
50	38.50	26.75	23.50	20.50	17.50	14.75	13.25	11.75
51	49.25	36.00	31.75	27.75	23.50	18.00	16.25	14.25
52	95.50	57.75	46.25	38.50	31.00	23.00	19.75	16.50
53	105.75	69.75	73.25	65.25	35.00	22.50	19.50	17.25
54	79.25	49.50	38.50	33.25	26.50	21.25	19.00	16.25
55	33.75	26.00	22.25	19.75	16.75	12.75	11.50	10.75
56	47.50	32.00	27.00	23.00	19.25	15.25	13.00	12.00
57	37.75	27.75	23.75	21.25	17.75	14.00	12.75	11.75
58	75.00	47.25	40.00	35.00	29.25	22.50	19.00	15.50
59	85.75	50.25	40.50	34.25	28.00	21.25	18.50	15.75
60	102.50	65.75	55.00	45.25	36.75	27.50	22.25	18.25
61	99.00	62.25	51.50	44.25	35.25	27.75	24.00	20.00
62	37.75	29.25	25.00	22.00	18.25	14.50	12.75	11.50
63	70.00	49.25	42.50	36.25	30.00	23.50	19.50	15.25
64	39.00	28.50	24.25	21.25	17.75	14.25	13.25	12.00
65	50.00	38.00	34.50	30.75	26.25	20.50	17.50	15.00
66	55.25	41.00	34.75	30.25	24.50	18.75	16.25	14.00
67	76.75	58.75	41.50	33.00	25.50	18.50	15.75	13.75
68	56.25	41.25	35.00	30.50	25.50	20.00	17.75	15.00
69	24.75	18.50	16.50	14.75	12.75	10.25	9.75	9.50
70	43.25	31.25	25.75	22.25	17.75	14.00	12.25	11.25
71	53.75	33.50	28.00	24.00	19.75	15.50	13.75	12.50
72	61.25	41.50	37.00	32.75	27.25	21.50	18.75	15.25
73	68.00	55.00	47.00	40.25	32.00	24.75	20.50	17.25

(Continued)

(Sheet 9 of 10)

Table 10 (Concluded)

Wave No.	Peak Pressure, psi, at Indicated Elevation, ft							
	+21	+20	+18	+16	+14	+12	+10	+8
<u>swl = 8.6 ft; T = 14 sec; H = 11.4 ft (Continued)</u>								
74	75.25	89.25	70.00	48.75	36.25	25.50	21.00	17.50
75	69.75	45.25	37.75	32.25	26.25	20.50	17.50	15.50
76	28.25	21.50	19.25	17.25	14.75	11.50	10.50	10.00
77	53.75	35.00	30.25	26.50	21.25	16.75	15.00	12.50
78	30.25	27.00	24.00	21.50	18.50	15.00	13.75	12.25
79	52.25	36.25	32.25	27.50	22.75	17.75	16.25	13.75
80	102.00	55.50	44.00	37.50	29.75	22.50	18.75	16.50
81	80.00	65.25	52.25	38.00	30.00	22.50	19.00	16.00
82	54.00	39.25	31.75	26.50	21.00	17.00	15.25	14.50
83	25.25	19.75	17.00	15.25	13.00	12.50	10.00	9.75
84	52.00	33.50	27.50	23.50	19.25	14.25	13.00	11.75
85	38.00	27.25	23.75	21.00	17.50	14.00	12.75	11.75
86	61.50	44.50	39.75	35.50	29.50	23.50	20.00	17.00
87	80.50	56.25	45.25	41.00	31.50	26.75	23.00	19.25
88	84.25	79.00	60.50	49.00	35.75	26.00	20.75	18.50
89	95.50	68.00	55.75	47.25	38.50	29.25	24.00	20.00
90	32.75	25.50	22.00	19.50	16.25	13.25	12.25	11.25
91	48.25	33.50	29.00	26.25	21.75	17.00	16.00	14.00
92	37.00	26.50	23.25	20.25	16.75	13.75	12.75	11.25
93	51.50	36.25	30.50	27.25	22.25	17.75	15.00	13.50
94	61.75	39.00	32.50	29.00	24.00	18.25	16.00	13.50
95	108.50	62.50	47.75	39.25	31.00	23.25	19.50	15.75
96	62.25	47.75	39.75	30.25	24.25	19.00	17.00	14.25
97	25.25	20.75	19.00	17.00	14.50	11.50	10.75	10.00
98	52.50	33.75	27.50	23.75	19.25	12.00	12.75	11.50
99	33.25	23.50	20.75	15.75	12.75	12.00	12.00	10.50
100	38.00	27.75	25.00	22.00	19.00	15.25	14.50	12.75
Min	22.50	18.50	16.25	14.75	12.75	10.25	9.75	9.50
Max	143.00	116.25	115.25	65.25	45.00	33.75	25.75	21.25
Mean	59.86	41.72	35.40	29.58	23.63	18.26	16.01	13.98
Std. Dev.	27.52	17.42	15.83	10.32	6.89	4.90	3.66	2.64

Table 11

Secondary Pressures on Modified Recurved Seawall, Plan R4S3

Wave No.	Secondary Pressure, psi, for Indicated Elevation, ft							
	+21	+20	+18	+16	+14	+12	+10	+8
<u>swl = 8.6 ft; T = 12 sec; H = 16.8 ft</u>								
1	--	0.00	1.25	1.75	2.50	3.50	4.75	5.50
2	--	0.00	1.25	2.50	2.75	3.75	4.25	5.00
3	--	0.00	1.25	2.50	2.75	3.75	4.50	5.25
4	--	0.00	1.50	2.50	3.00	3.50	4.50	5.50
5	--	0.00	2.00	2.50	3.25	3.50	4.75	5.25
6	--	0.25	1.50	2.00	3.00	3.50	4.50	5.50
7	--	0.25	1.00	1.75	2.75	3.25	4.50	5.50
8	--	0.00	0.75	1.75	2.75	3.25	4.50	5.00
9	--	0.50	1.25	1.75	3.25	3.25	4.25	5.00
10	--	0.50	1.00	2.25	3.00	3.25	4.25	5.25
11	--	0.75	1.25	2.00	3.00	3.50	4.00	4.25
12	--	0.50	1.25	2.50	3.25	3.50	4.00	5.00
13	--	0.75	1.50	2.00	3.25	3.50	4.50	4.75
14	--	0.50	1.50	2.25	3.00	3.50	4.50	5.25
15	--	0.50	1.75	2.00	3.00	3.50	4.50	5.50
16	--	0.50	1.50	2.75	3.25	3.75	4.00	5.25
17	--	0.00	1.50	1.75	2.75	3.00	4.75	5.00
18	--	0.00	1.50	2.00	3.25	3.50	4.25	5.00
19	--	0.25	1.00	1.75	3.25	3.25	4.25	5.25
20	--	0.25	1.25	2.00	3.00	3.50	4.75	5.50
21	--	0.25	1.25	2.00	3.00	3.50	4.50	5.00
22	--	0.75	1.75	2.25	3.00	3.25	4.50	5.25
23	--	0.75	1.25	2.00	3.00	3.75	4.00	5.00
24	--	0.75	1.25	2.25	3.25	3.50	4.50	5.50
25	--	0.75	1.00	2.00	3.00	3.25	4.25	4.75
26	--	0.75	1.25	2.25	3.25	3.25	4.50	5.50
27	--	0.75	1.25	2.00	3.00	3.50	4.50	5.00
28	--	0.75	1.25	2.50	3.00	3.50	4.50	5.50
29	--	0.75	1.25	1.75	3.00	3.75	4.50	5.25
30	--	0.75	1.25	2.00	2.75	3.50	4.50	5.25
31	--	0.50	1.50	1.75	3.00	3.75	4.50	5.25
32	--	0.50	1.50	1.75	3.50	3.50	4.75	5.25
33	--	0.25	1.25	2.00	2.75	3.50	4.50	5.25
34	--	0.25	1.00	2.25	2.75	3.75	4.50	5.25
35	--	0.50	1.50	2.25	3.00	3.75	4.75	5.25
36	--	0.50	1.50	2.25	3.25	3.50	4.75	5.75
37	--	1.00	1.75	2.50	3.50	4.00	4.75	5.50
38	--	0.50	1.25	2.25	3.75	3.75	5.00	5.75
39	--	0.75	1.50	2.25	3.00	3.75	4.75	5.25
40	--	0.50	1.50	2.25	3.50	4.00	5.00	5.50
41	--	0.25	1.75	2.25	2.75	3.50	4.50	5.00
42	--	0.50	1.25	2.00	3.00	3.25	4.50	5.75
43	--	0.50	1.25	2.00	3.00	3.75	4.50	5.00

(Continued)

(Sheet 1 of 10)

Table 11 (Continued)

Wave No.	Secondary Pressure, psi, for Indicated Elevation, ft							
	+21	+20	+18	+16	+14	+12	+10	+8
<u>swl = 8.6 ft; T = 12 sec; H = 16.8 ft (Continued)</u>								
44	--	0.50	1.00	2.25	3.00	3.25	4.75	5.50
45	--	0.50	1.25	2.25	3.00	3.25	4.25	5.25
46	--	0.75	1.25	2.00	3.25	3.50	4.75	5.25
47	--	0.75	1.50	2.25	3.25	3.50	5.00	5.25
48	--	1.00	1.50	2.25	3.25	3.75	4.75	5.00
49	--	0.25	0.75	2.00	2.50	3.25	4.50	5.25
50	--	0.25	1.00	2.25	3.00	3.75	4.50	5.50
51	--	0.50	1.50	2.25	2.75	3.50	4.50	5.25
52	--	0.50	1.25	2.25	2.75	3.50	4.75	5.25
53	--	0.75	1.75	2.00	3.25	3.75	4.75	5.25
54	--	0.25	1.75	2.50	3.25	3.75	4.75	5.25
55	--	0.75	1.50	2.25	3.25	3.50	4.50	5.50
56	--	0.50	1.75	2.25	3.25	3.75	4.75	5.50
57	--	0.00	1.25	2.00	3.00	3.25	4.25	5.25
58	--	0.50	1.25	2.00	2.75	3.25	4.75	5.25
59	--	0.25	1.25	2.25	3.00	3.75	4.75	5.50
60	--	0.50	1.00	2.25	3.00	3.50	4.75	5.00
61	--	0.50	1.50	2.00	3.25	3.75	4.75	5.25
62	--	0.50	1.50	2.25	3.25	3.50	4.50	5.00
63	--	0.50	1.75	2.00	3.50	3.75	4.50	5.25
64	--	0.50	1.25	2.00	3.25	3.75	4.50	5.25
65	--	0.25	1.25	1.75	2.50	3.50	4.50	5.25
66	--	0.50	1.75	2.50	3.00	3.25	4.25	5.25
67	--	0.50	2.00	2.00	3.00	4.00	4.50	5.00
68	--	0.50	1.50	2.00	3.25	3.75	4.50	5.00
69	--	0.50	1.50	2.25	3.50	3.50	4.75	5.50
70	--	0.50	1.50	2.25	3.50	3.75	5.00	5.75
71	--	0.50	1.25	2.00	3.25	3.75	4.75	5.25
72	--	0.75	1.25	2.25	3.25	4.00	4.75	5.50
73	--	0.25	1.25	1.75	3.00	3.75	4.25	5.00
74	--	0.25	1.00	2.00	2.75	3.75	4.50	5.25
75	--	0.50	1.25	1.75	3.00	3.50	4.75	5.00
76	--	0.50	1.50	2.25	3.25	3.50	4.75	5.25
77	--	0.50	1.25	2.25	3.25	3.75	4.50	5.50
78	--	0.25	1.50	2.00	3.00	3.75	5.00	5.75
79	--	0.50	1.25	2.00	3.25	3.75	4.50	5.50
80	--	0.50	1.25	2.00	3.50	4.00	4.75	5.50
81	--	0.50	1.50	2.00	3.00	3.00	4.25	5.25
82	--	0.50	1.25	2.00	3.00	3.50	4.50	5.25
83	--	0.75	1.25	2.25	3.25	3.50	4.50	5.50
84	--	0.75	1.25	2.00	3.00	3.50	4.75	5.50
85	--	0.75	1.25	2.25	3.25	4.00	4.75	5.75
86	--	1.00	1.50	2.00	3.25	3.50	4.50	5.25
87	--	0.75	1.75	2.25	3.25	4.00	4.75	5.75
88	--	0.50	1.50	2.25	3.00	3.75	4.25	5.25

(Continued)

(Sheet 2 of 10)

Table 11 (Continued)

Wave No.	Secondary Pressure, psi, for Indicated Elevation, ft							
	+21	+20	+18	+16	+14	+12	+10	+8
<u>swl = 8.6 ft; T = 12 sec; H = 16.8 ft (Continued)</u>								
89	--	0.25	1.25	2.00	2.50	3.25	4.25	5.00
90	--	0.25	1.25	2.25	3.00	3.50	4.50	5.25
91	--	0.50	1.25	2.00	2.75	3.50	4.50	5.50
92	--	0.25	1.25	2.00	3.00	3.50	4.75	5.25
93	--	0.50	1.50	2.25	3.25	3.75	4.75	5.75
94	--	0.50	1.50	2.25	3.25	3.50	5.00	5.50
95	--	0.50	1.25	2.00	3.25	3.50	5.00	5.50
96	--	0.50	1.50	2.25	3.25	4.00	4.75	5.75
97	--	0.00	1.00	1.75	3.00	3.50	4.50	5.00
98	--	0.50	1.50	2.00	3.00	3.50	4.50	5.25
99	--	0.50	1.50	2.50	3.00	3.50	4.50	5.50
100	--	0.75	1.00	2.25	3.00	3.50	4.50	5.50
Min	--	0.00	0.75	1.75	2.50	3.00	4.00	4.25
Max	--	1.00	2.00	2.75	3.75	4.00	5.00	5.75
Mean	--	0.47	1.36	2.12	3.07	3.57	4.56	5.30
Std. Dev.	--	0.24	0.24	0.22	0.24	0.22	0.23	0.26

swl = 8.6 ft; T = 12 sec; H = 16.0 ft

1	--	0.00	1.00	1.75	3.00	3.50	4.50	5.25
2	--	0.00	1.50	2.50	3.00	3.50	4.75	5.25
3	--	0.75	1.25	2.25	3.25	3.75	4.75	5.50
4	--	0.75	1.50	2.25	3.25	4.00	4.75	5.50
5	--	0.75	1.50	2.00	3.25	4.00	4.50	5.50
6	--	0.75	1.50	2.00	3.50	3.75	4.50	5.25
7	--	0.75	1.75	2.25	3.25	4.00	4.75	5.50
8	--	1.00	1.50	2.00	2.75	4.00	4.50	5.75
9	--	0.50	1.25	1.75	2.75	3.75	4.50	5.00
10	--	0.50	1.25	2.25	3.25	3.75	4.75	5.50
11	--	0.50	1.25	2.25	3.00	3.50	4.75	5.25
12	--	0.75	1.50	2.25	3.25	4.00	4.75	5.25
13	--	0.75	1.50	2.50	3.50	4.00	4.75	5.75
14	--	0.75	1.75	2.50	3.50	3.75	5.00	5.25
15	--	0.50	1.25	2.25	3.75	3.75	4.50	5.25
16	--	0.50	1.50	2.25	3.25	3.50	5.00	5.50
17	--	0.25	1.25	1.75	2.75	3.50	4.75	5.25
18	--	0.75	1.00	2.00	3.00	3.50	4.50	5.25
19	--	0.50	1.25	2.00	2.75	3.75	4.75	5.25
20	--	0.50	1.50	2.00	2.75	3.50	4.50	5.50
21	--	0.50	1.25	2.25	3.00	3.75	4.50	5.50
22	--	0.75	1.50	2.25	3.00	4.00	4.75	5.50
23	--	0.75	1.50	2.00	3.25	3.75	4.50	5.50

(Continued)

(Sheet 3 of 10)

Table 11 (Continued)

Wave No.	Secondary Pressure, psi, for Indicated Elevation, ft							
	+21	+20	+18	+16	+14	+12	+10	+8
<u>swl = 8.6 ft; T = 12 sec; H = 16.0 ft (Continued)</u>								
24	--	0.75	1.75	2.25	3.75	4.00	4.75	5.00
25	--	0.50	1.25	1.75	3.00	3.50	4.50	5.25
26	--	0.50	1.25	2.00	3.00	3.75	4.75	5.25
27	--	0.50	1.25	2.00	3.25	3.75	4.50	5.25
28	--	0.50	1.25	2.00	3.25	3.75	4.25	5.25
29	--	0.75	1.25	2.25	3.50	3.75	4.50	5.50
30	--	0.50	1.25	2.25	2.75	3.75	4.50	5.25
31	--	0.75	1.50	2.50	3.00	3.75	4.75	5.25
32	--	0.50	1.25	1.75	3.00	3.75	4.50	5.00
33	--	0.50	1.25	2.00	3.00	3.50	4.75	5.00
34	--	0.50	1.25	2.25	3.00	3.75	5.00	5.50
35	--	0.50	1.25	2.00	3.25	4.00	5.00	5.00
36	--	0.75	1.75	2.25	3.25	3.75	4.75	5.75
37	--	0.75	1.75	2.50	3.25	3.75	4.50	5.50
38	--	0.50	1.50	2.00	3.50	4.50	5.00	5.50
39	--	0.50	1.25	2.25	3.25	3.75	4.75	5.50
40	--	0.75	1.50	2.00	2.75	3.75	4.25	5.00
41	--	0.75	2.00	2.50	3.25	4.00	4.75	5.50
42	--	0.50	1.25	2.00	3.00	3.75	4.50	5.25
43	--	0.75	1.75	2.25	3.00	4.00	4.50	5.50
44	--	1.00	1.50	2.25	3.25	4.00	4.75	5.50
45	--	0.50	1.50	2.25	3.50	3.50	5.00	5.25
46	--	0.75	1.50	2.00	3.25	3.50	4.50	5.25
47	--	0.50	1.75	2.25	3.25	3.75	4.75	5.25
48	--	0.50	1.25	1.75	2.75	3.50	4.25	5.25
49	--	0.75	1.50	2.00	3.25	3.75	4.75	5.50
50	--	0.75	1.75	2.25	3.00	4.00	4.75	5.50
51	--	0.75	1.75	2.50	3.25	4.00	4.75	5.50
52	--	0.75	1.75	2.25	3.50	4.00	4.75	6.00
53	--	0.75	1.75	2.25	3.25	3.75	4.75	5.25
54	--	0.75	1.50	2.50	3.25	4.00	5.00	5.75
55	--	0.75	1.50	2.25	3.50	3.50	4.75	5.25
56	--	0.25	1.00	2.00	3.00	3.50	4.50	5.25
57	--	0.50	1.25	2.00	3.00	3.50	4.50	5.25
58	--	0.50	1.25	2.00	2.75	3.50	4.75	5.50
59	--	0.75	1.50	2.00	3.00	3.75	4.75	5.25
60	--	0.50	1.50	2.25	3.50	4.00	4.75	5.50
61	--	0.75	1.25	2.25	3.00	3.50	4.75	5.50
62	--	0.75	1.50	2.50	3.00	4.00	4.75	5.50
63	--	0.75	1.75	2.50	3.75	3.50	4.75	5.50
64	--	0.50	1.50	1.75	2.50	3.75	4.25	5.25
65	--	0.50	1.75	2.00	3.00	4.00	4.50	5.25
66	--	0.50	1.50	2.00	3.25	3.75	4.25	5.50
67	--	1.00	1.50	2.25	3.50	3.75	4.50	5.50
68	--	0.75	1.75	2.75	3.50	3.75	4.50	5.25

(Continued)

(Sheet 4 of 10)

Table 11 (Continued)

Wave No.	Secondary Pressure, psi, for Indicated Elevation, ft							
	+21	+20	+18	+16	+14	+12	+10	+8
<u>swl = 8.6 ft; T = 12 sec; H = 16.0 ft (Continued)</u>								
69	--	0.75	1.50	2.00	3.25	4.00	4.50	5.75
70	--	0.75	1.50	2.25	3.50	4.25	4.25	5.00
71	--	0.75	1.50	2.25	3.50	4.25	4.50	5.00
72	--	0.50	0.75	2.00	2.75	3.25	4.50	5.50
73	--	0.50	1.50	2.25	3.00	3.25	4.25	5.25
74	--	0.75	1.50	2.50	3.25	3.75	4.75	5.50
75	--	1.00	1.50	2.00	3.25	4.00	4.25	5.25
76	--	0.75	1.75	2.25	3.25	3.75	4.50	5.25
77	--	0.75	1.50	2.25	3.00	3.75	4.25	5.25
78	--	0.75	1.50	2.50	3.50	4.25	4.75	5.50
79	--	0.50	1.75	2.50	3.00	4.00	4.50	5.50
80	--	1.00	1.50	2.00	2.75	3.25	4.50	5.25
81	--	1.25	1.75	2.25	3.25	4.25	5.00	5.25
82	--	1.25	1.25	2.25	3.00	3.75	4.50	5.25
83	--	1.25	1.75	2.25	3.00	3.75	4.75	5.25
84	--	2.25	1.50	2.50	3.50	3.75	4.75	5.50
85	--	2.00	1.75	2.50	3.50	3.75	4.75	5.50
86	--	1.75	1.75	2.25	3.25	3.75	5.00	5.50
87	--	1.75	2.00	2.50	3.25	4.00	4.50	5.50
88	--	0.75	1.25	2.00	3.00	3.50	4.25	5.00
89	--	0.75	1.50	2.00	2.75	4.00	4.50	5.25
90	--	0.75	1.50	2.50	3.75	4.25	4.75	5.75
91	--	0.50	1.50	2.25	3.25	4.00	4.50	5.50
92	--	0.75	1.50	2.50	3.50	4.00	4.75	5.75
93	--	1.00	1.50	2.50	3.25	3.75	5.00	5.75
94	--	0.75	1.75	2.50	3.75	4.00	4.75	5.50
95	--	0.75	1.50	2.50	3.50	4.00	4.75	5.75
96	--	0.50	1.25	2.25	2.75	3.50	4.50	5.00
97	--	0.75	1.50	2.25	3.00	3.75	5.00	5.25
98	--	0.75	1.75	2.50	3.25	3.75	5.00	5.50
99	--	1.00	1.50	2.75	3.25	4.00	5.00	5.50
100	--	0.75	1.75	2.75	3.75	4.50	5.50	6.00
Min	--	0.00	0.75	1.75	2.50	3.25	4.25	5.00
Max	--	2.25	2.00	2.75	3.75	4.50	5.50	6.00
Mean	--	0.72	1.48	2.21	3.18	3.80	4.65	5.38
Std. Dev.	--	0.33	0.22	0.24	0.28	0.24	0.23	0.22

swl = 8.6 ft; T = 14 sec; H = 17.0 ft

1	--	0.50	1.75	2.25	3.50	3.75	4.00	5.25
2	--	0.75	1.25	2.25	3.50	3.75	4.50	5.00
3	--	0.50	1.50	2.25	3.25	4.00	4.75	4.75

(Continued)

(Sheet 5 of 10)

Table 11 (Continued)

Wave No.	Secondary Pressure, psi, for Indicated Elevation, ft							
	+21	+20	+18	+16	+14	+12	+10	+8
<u>swl = 8.6 ft; T = 14 sec; H = 17.0 ft (Continued)</u>								
4	--	0.75	1.50	2.25	3.25	3.75	4.50	5.25
5	--	1.00	1.75	2.25	3.25	4.00	4.75	5.25
6	--	1.00	1.50	2.25	3.25	4.00	4.50	5.00
7	--	1.00	1.25	2.00	3.25	4.00	4.50	5.00
8	--	0.25	1.25	2.00	3.25	4.00	4.75	5.00
9	--	0.50	1.50	2.25	3.25	4.25	5.00	5.25
10	--	0.50	1.50	2.25	3.50	4.25	5.00	5.25
11	--	0.50	1.50	2.25	3.50	3.50	4.50	5.50
12	--	0.50	1.75	2.25	3.50	3.75	4.75	5.25
13	--	0.75	1.75	2.50	3.75	4.00	4.75	5.00
14	--	0.75	1.50	2.25	2.75	3.75	4.50	5.50
15	--	0.50	1.50	2.25	3.25	4.00	4.50	5.50
16	--	0.50	1.75	2.25	3.50	4.00	4.75	5.25
17	--	0.50	1.50	2.25	3.50	4.00	4.75	5.00
18	--	0.50	1.50	2.25	3.75	3.75	4.75	5.25
19	--	0.75	2.00	2.50	3.50	3.75	4.75	5.25
20	--	0.75	1.75	2.50	3.50	3.50	4.75	5.25
21	--	0.50	1.50	2.25	3.00	4.00	4.50	5.50
22	--	0.50	1.50	2.25	3.50	4.00	5.00	5.25
23	--	0.50	1.50	2.00	3.50	4.00	4.75	5.25
24	--	0.75	1.50	2.50	3.25	4.00	4.75	4.50
25	--	0.75	1.75	2.50	3.50	4.00	4.75	5.00
26	--	0.75	1.75	2.25	3.00	3.75	4.75	5.50
27	--	0.75	1.50	2.25	3.25	3.50	4.75	5.25
28	--	0.50	1.25	2.50	2.75	3.50	4.50	5.50
29	--	0.50	1.75	2.25	3.25	3.75	4.75	5.25
30	--	0.50	1.25	2.25	3.50	3.75	5.00	5.25
31	--	0.50	1.75	2.50	3.25	4.00	4.50	5.50
32	--	0.75	1.50	2.00	3.25	3.75	4.75	5.25
33	--	0.75	1.50	2.50	3.25	4.00	4.75	5.25
34	--	0.75	1.50	2.50	3.50	4.00	4.75	5.25
35	--	0.75	1.50	2.50	3.25	3.75	5.00	5.25
36	--	0.50	1.50	2.00	3.50	4.00	4.50	5.25
37	--	0.75	1.50	2.25	3.50	3.75	4.75	5.50
38	--	0.50	1.50	2.25	3.25	3.75	4.50	4.75
39	--	0.75	1.75	2.50	3.25	3.50	4.50	5.00
40	--	1.00	1.50	2.25	3.25	3.75	4.75	4.75
41	--	1.00	1.50	2.50	3.25	3.75	4.75	5.50
42	--	0.75	1.50	2.25	3.50	3.75	4.75	5.25
43	--	0.50	1.75	2.25	3.25	4.00	4.75	5.00
44	--	0.75	1.25	2.25	3.50	3.75	4.25	5.00
45	--	0.75	1.75	2.00	3.50	3.75	4.75	4.75
46	--	0.75	1.50	2.50	3.25	4.00	4.50	5.00
47	--	1.00	1.50	2.00	3.25	3.75	5.00	4.75
48	--	1.00	1.25	2.25	3.50	4.00	5.00	5.25

(Continued)

(Sheet 6 of 10)

Table 11 (Continued)

Wave No.	Secondary Pressure, psi, for Indicated Elevation, ft							
	+21	+20	+18	+16	+14	+12	+10	+8
<u>swl = 8.6 ft; T = 14 sec; H = 17.0 ft (Continued)</u>								
49	--	0.75	1.25	2.00	3.00	3.50	4.50	5.00
50	--	0.75	1.50	2.25	3.25	3.50	4.50	5.50
51	---	0.75	1.50	2.25	3.25	3.75	4.50	5.25
52	--	1.00	1.25	2.00	3.25	3.75	4.75	5.00
53	---	0.75	1.75	2.25	3.25	3.50	4.50	5.50
54	--	0.75	1.00	2.00	3.00	3.75	4.75	4.75
55	--	0.75	1.50	2.25	3.50	4.25	4.75	5.25
56	--	0.75	1.25	2.00	3.00	3.75	4.50	5.75
57	---	0.50	1.50	2.25	3.25	3.75	4.75	5.25
58	--	0.75	1.50	2.25	3.50	3.75	4.50	5.75
59	---	0.50	1.50	2.25	2.75	3.75	4.50	4.75
60	---	0.75	1.25	2.25	3.25	3.75	5.00	5.00
61	---	0.75	1.50	2.00	2.75	3.25	5.00	5.25
62	--	0.50	1.25	2.25	3.50	3.75	5.00	4.50
63	--	0.75	1.25	2.00	2.75	3.50	5.00	5.25
64	---	0.25	1.50	2.25	3.50	3.50	4.50	5.50
65	---	0.25	1.75	2.25	3.50	3.75	4.75	5.50
66	---	0.50	1.50	2.25	3.00	3.75	5.00	5.25
67	---	0.50	2.00	2.50	3.50	4.00	4.75	5.00
68	---	0.75	1.25	2.25	3.50	4.25	5.00	5.00
69	---	0.75	1.50	2.25	2.75	4.00	4.75	5.00
70	--	0.75	1.25	2.50	3.25	4.25	5.00	4.25
71	--	0.50	1.75	2.75	3.50	4.25	4.75	5.75
72	---	0.75	1.50	2.25	3.25	3.75	4.75	5.25
73	---	1.00	1.50	2.25	3.50	4.25	5.00	4.75
74	--	1.00	1.50	2.25	3.00	4.00	5.25	5.25
75	--	0.50	1.25	2.50	3.50	3.75	4.75	5.00
76	--	0.75	1.50	2.75	3.25	3.50	5.00	5.25
77	---	0.75	1.75	2.25	3.00	3.50	4.75	5.25
78	--	1.00	1.75	2.25	3.00	3.75	5.00	5.50
79	--	0.75	2.00	2.50	3.50	3.50	5.25	5.00
80	--	0.75	1.50	2.50	3.50	4.00	5.00	5.25
81	---	1.00	1.50	2.50	3.25	3.50	4.75	5.00
82	---	1.00	1.25	2.25	3.50	3.75	4.75	5.25
83	--	1.00	1.25	2.25	3.25	3.75	5.00	5.50
84	---	0.50	1.50	2.25	3.25	3.25	4.75	5.50
85	---	0.75	1.75	2.50	3.50	3.75	5.00	5.50
86	--	0.75	1.50	2.25	3.00	4.00	4.25	5.25
87	--	0.75	1.50	2.25	3.50	4.00	5.00	5.25
88	---	1.00	1.50	2.50	3.50	3.75	4.75	5.50
89	---	0.75	1.50	2.25	3.50	4.50	5.00	5.25
90	--	0.75	1.75	2.25	3.25	3.75	4.75	5.50
91	---	0.50	1.50	2.25	3.50	3.75	4.50	5.50
92	---	0.75	1.75	2.50	3.50	4.00	5.25	5.25
93	---	0.75	2.00	2.75	3.75	4.25	5.00	5.00

(Continued)

(Sheet 7 of 10)

Table 11 (Continued)

Wave No.	Secondary Pressure, psi, for Indicated Elevation, ft							
	+21	+20	+18	+16	+14	+12	+10	+8
<u>swl = 8.6 ft; T = 14 sec; H = 17.0 ft (Continued)</u>								
94	--	1.00	1.75	2.50	3.75	4.00	5.50	4.75
95	--	1.00	1.75	2.50	4.00	4.25	5.00	5.25
96	--	0.75	1.75	2.00	3.25	3.50	5.00	5.75
97	--	0.50	1.25	2.00	3.00	3.75	4.75	4.50
98	--	0.75	1.50	2.25	3.25	3.75	5.00	5.00
99	--	0.50	1.50	2.00	3.25	4.00	5.25	5.50
100	--	0.75	1.50	2.25	3.50	3.75	5.00	5.25
Min	--	0.25	1.25	2.00	2.75	3.25	4.00	4.25
Max	--	1.00	2.00	2.75	4.00	4.50	5.50	5.75
Mean	--	0.70	1.52	2.28	3.32	3.83	4.77	5.19
Std. Dev.	--	0.19	0.20	0.17	0.24	0.23	0.24	0.29

swl = 8.6 ft; T = 14 sec; H = 11.4 ft

1	--	1.25	2.25	3.00	3.50	4.25	5.50	5.75
2	--	1.25	1.75	2.75	3.75	4.25	5.25	5.50
3	--	1.25	2.00	2.75	4.00	4.50	5.50	6.00
4	--	1.25	2.00	3.00	3.75	4.25	5.25	5.75
5	--	1.25	2.00	2.50	4.00	4.25	5.50	5.75
6	--	1.25	2.25	3.00	3.50	4.00	5.50	6.00
7	--	1.25	2.25	2.75	4.00	4.75	5.50	5.50
8	--	1.25	2.25	2.75	4.00	4.75	5.50	5.50
9	--	1.25	2.00	3.00	4.25	4.50	5.75	5.75
10	--	1.25	2.25	3.00	4.25	4.50	5.75	5.75
11	--	1.25	2.00	3.00	3.75	4.25	5.50	5.75
12	--	1.50	1.75	3.00	4.25	4.25	5.50	5.50
13	--	1.75	2.00	2.75	4.25	4.50	5.50	6.00
14	--	1.25	2.00	3.00	3.50	4.25	5.00	5.50
15	--	1.00	2.00	2.50	4.00	4.50	5.25	5.75
16	--	1.25	1.75	2.50	4.00	4.25	5.25	5.25
17	--	1.00	2.00	2.75	3.75	3.75	5.00	5.75
18	--	1.25	2.00	3.00	3.75	4.00	5.50	5.75
19	--	1.25	2.00	2.75	3.75	4.25	5.25	5.50
20	--	1.50	2.25	3.50	4.00	4.75	5.75	5.50
21	--	1.50	2.00	3.25	3.75	4.75	5.50	5.75
22	--	1.00	2.25	3.25	3.75	4.00	5.00	5.50
23	--	1.00	2.25	2.75	3.75	4.00	5.00	5.50
24	--	1.00	1.75	2.50	3.25	4.00	5.50	5.50
25	--	1.25	2.00	2.75	3.75	4.25	5.00	5.75
26	--	1.00	1.75	2.75	3.50	4.00	4.75	5.50
27	--	1.25	1.75	3.00	3.75	4.50	5.50	5.75
28	--	1.00	1.75	2.75	4.00	4.50	5.50	5.75

(Continued)

(Sheet 8 of 10)

Table 11 (Continued)

Wave No.	Secondary Pressure, psi, for Indicated Elevation, ft							
	+21	+20	+18	+16	+14	+12	+10	+8
<u>swl = 8.6 ft; T = 14 sec; H = 11.4 ft (Continued)</u>								
29	--	1.25	2.00	2.75	4.00	4.25	5.25	5.75
30	--	1.25	1.75	2.75	3.75	4.25	5.50	5.50
31	--	1.25	2.25	3.00	4.25	4.50	5.50	6.00
32	--	1.25	2.00	2.75	3.50	4.25	5.25	5.75
33	--	1.25	2.00	2.50	3.75	4.00	5.25	5.75
34	--	1.50	2.00	3.00	4.25	4.50	5.25	5.75
35	--	1.50	2.00	2.75	3.75	4.50	5.75	5.75
36	--	1.25	1.75	2.75	4.25	4.00	5.25	5.75
37	--	1.00	2.00	2.75	4.00	4.25	5.25	5.25
38	--	1.25	1.75	2.50	3.50	4.00	5.00	5.50
39	--	1.25	1.75	3.00	4.00	4.25	5.75	5.75
40	--	1.25	2.00	2.75	4.00	4.00	5.25	5.75
41	--	1.50	2.25	3.25	4.50	4.75	5.75	6.00
42	--	1.50	2.50	3.25	4.00	4.25	5.25	6.25
43	--	1.00	2.00	2.50	3.75	4.00	5.50	5.50
44	--	1.00	2.00	2.75	4.00	4.25	5.50	5.25
45	--	1.25	2.00	2.75	4.25	4.50	5.50	5.50
46	--	1.25	2.00	3.00	4.25	4.50	5.25	5.75
47	--	1.25	2.00	2.75	4.25	4.25	5.25	5.50
48	--	1.25	2.25	3.25	4.25	4.50	5.75	5.75
49	--	1.25	2.00	2.75	3.75	4.00	5.00	5.50
50	--	1.50	2.25	3.00	4.25	4.50	5.50	5.75
51	--	1.25	2.25	2.75	4.25	4.50	5.25	5.75
52	--	1.25	2.00	2.75	4.00	4.00	5.25	5.50
53	--	1.25	1.75	3.00	3.75	4.25	5.25	5.50
54	--	1.25	1.75	2.75	3.50	4.00	5.50	5.25
55	--	1.50	2.00	3.25	4.25	4.50	5.50	5.75
56	--	1.25	2.00	2.75	3.75	4.50	5.25	5.75
57	--	1.25	2.00	3.00	4.00	4.50	5.50	5.50
58	--	1.25	2.25	2.75	3.75	4.25	5.25	5.50
59	--	1.25	2.25	2.75	4.00	4.25	5.25	5.50
60	--	1.25	2.00	2.50	3.75	4.00	5.25	5.50
61	--	1.25	1.75	2.75	3.75	4.00	5.50	5.75
62	--	1.50	2.00	3.00	4.25	4.50	5.75	5.75
63	--	1.25	1.75	2.50	3.50	4.50	5.25	5.25
64	--	1.25	2.00	3.00	4.00	4.50	5.50	5.25
65	--	1.25	2.00	2.75	3.75	4.25	5.25	5.50
66	--	1.25	2.00	3.00	4.00	4.25	5.75	5.75
67	--	1.25	2.00	3.25	4.00	4.25	5.25	5.25
68	--	1.25	1.50	2.75	4.25	4.50	5.25	5.50
69	--	1.50	2.25	3.25	4.25	4.75	5.75	5.75
70	--	1.50	1.75	3.25	3.75	4.50	5.25	5.75
71	--	1.25	2.00	3.00	4.00	4.25	5.25	5.75
72	--	1.50	2.00	3.25	4.25	4.75	5.50	5.50
73	--	1.25	2.00	3.00	4.00	4.25	5.00	5.50

(Continued)

(Sheet 9 of 10)

Table 11 (Concluded)

Wave No.	Secondary Pressure, psi, for Indicated Elevation, ft							
	+21	+20	+18	+16	+14	+12	+10	+8
<u>swl = 8.6 ft; T = 14 sec; H = 11.4 ft (Continued)</u>								
74	--	1.25	1.75	2.75	4.00	4.00	5.50	5.75
75	--	1.25	1.75	2.75	3.75	4.25	5.25	5.50
76	--	1.50	2.00	3.50	4.75	4.50	5.25	6.00
77	--	1.25	2.00	3.25	4.00	4.50	5.75	5.50
78	--	1.25	2.00	2.75	4.00	4.25	5.25	5.25
79	--	1.25	2.00	3.25	3.75	4.25	5.75	5.75
80	--	1.25	2.00	3.00	3.75	4.00	5.25	5.75
81	--	1.50	1.75	2.75	4.00	4.50	5.25	5.75
82	--	1.25	2.00	3.00	3.75	4.25	5.00	5.75
83	--	1.50	2.25	3.00	4.00	4.75	5.50	6.00
84	--	1.50	2.25	3.00	4.00	4.25	5.25	5.75
85	--	1.25	2.00	2.25	3.75	4.50	5.50	5.75
86	--	1.00	1.75	2.75	3.75	4.50	5.25	5.50
87	--	1.25	2.00	3.00	4.00	4.50	5.50	5.50
88	--	1.25	2.00	2.75	3.75	4.50	5.00	5.75
89	--	1.25	1.75	3.00	4.00	4.25	5.00	5.75
90	--	1.25	2.00	3.00	4.00	4.50	5.50	5.50
91	--	1.25	2.00	3.50	3.75	4.50	5.00	5.25
92	--	1.25	2.50	2.75	4.00	4.50	5.50	5.25
93	--	1.00	1.75	3.00	3.75	4.25	5.25	5.50
94	--	1.25	2.25	3.00	3.75	4.50	5.50	5.50
95	--	1.50	2.00	3.00	4.00	4.25	5.50	5.50
96	--	1.25	2.00	3.00	4.25	4.50	5.50	5.75
97	--	1.50	2.00	3.25	4.25	4.50	6.00	6.00
98	--	1.50	2.25	3.25	4.25	4.50	5.25	5.75
99	--	1.25	2.25	2.75	4.25	4.25	5.50	5.50
100	--	1.25	2.00	2.75	4.00	4.25	5.50	5.25
Min	--	1.00	1.50	2.50	3.25	3.75	4.75	5.25
Max	--	1.75	2.50	3.50	4.75	4.75	6.00	6.25
Mean	--	1.28	2.00	2.88	3.94	4.33	5.38	5.63
Std. Dev.	--	0.15	0.19	0.32	0.26	0.22	0.23	0.21

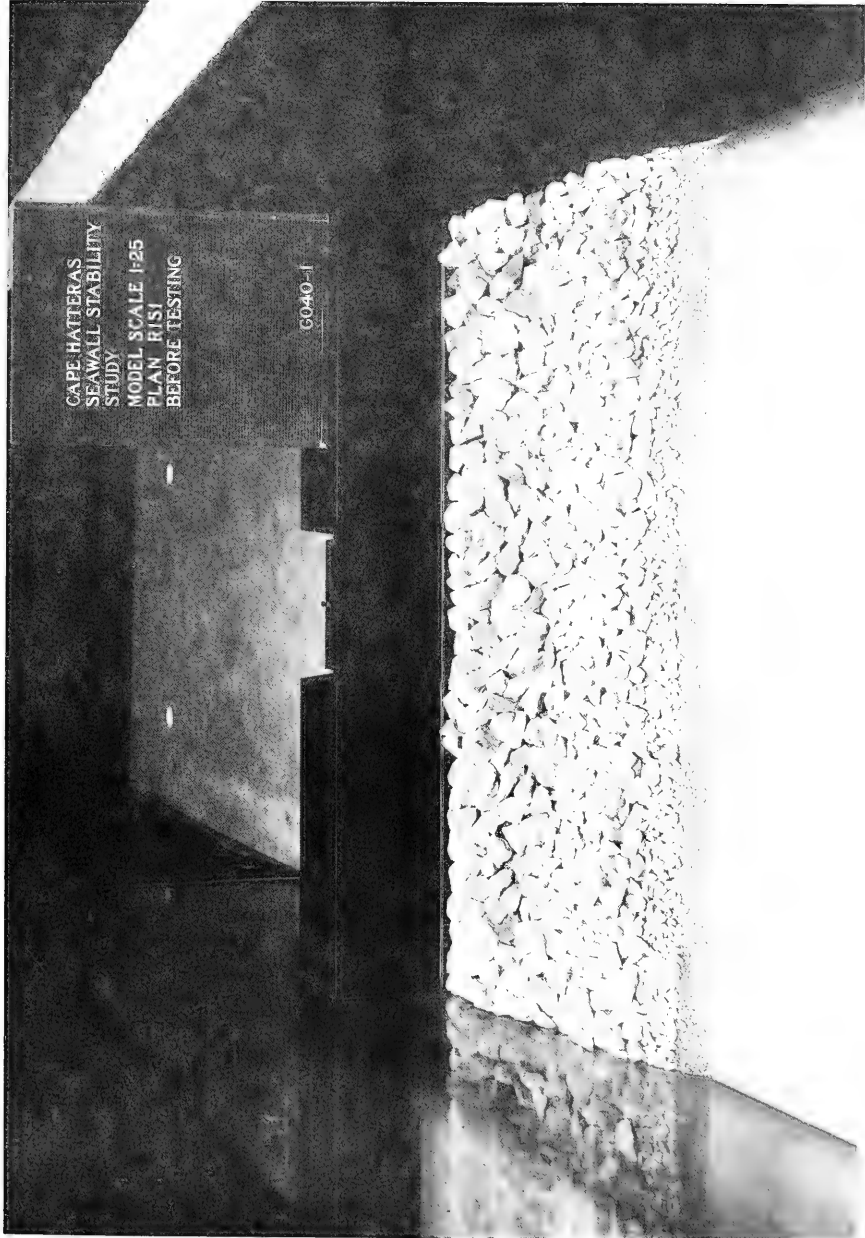

Photo 1. Sea-side view of Plan RIS1 before testing

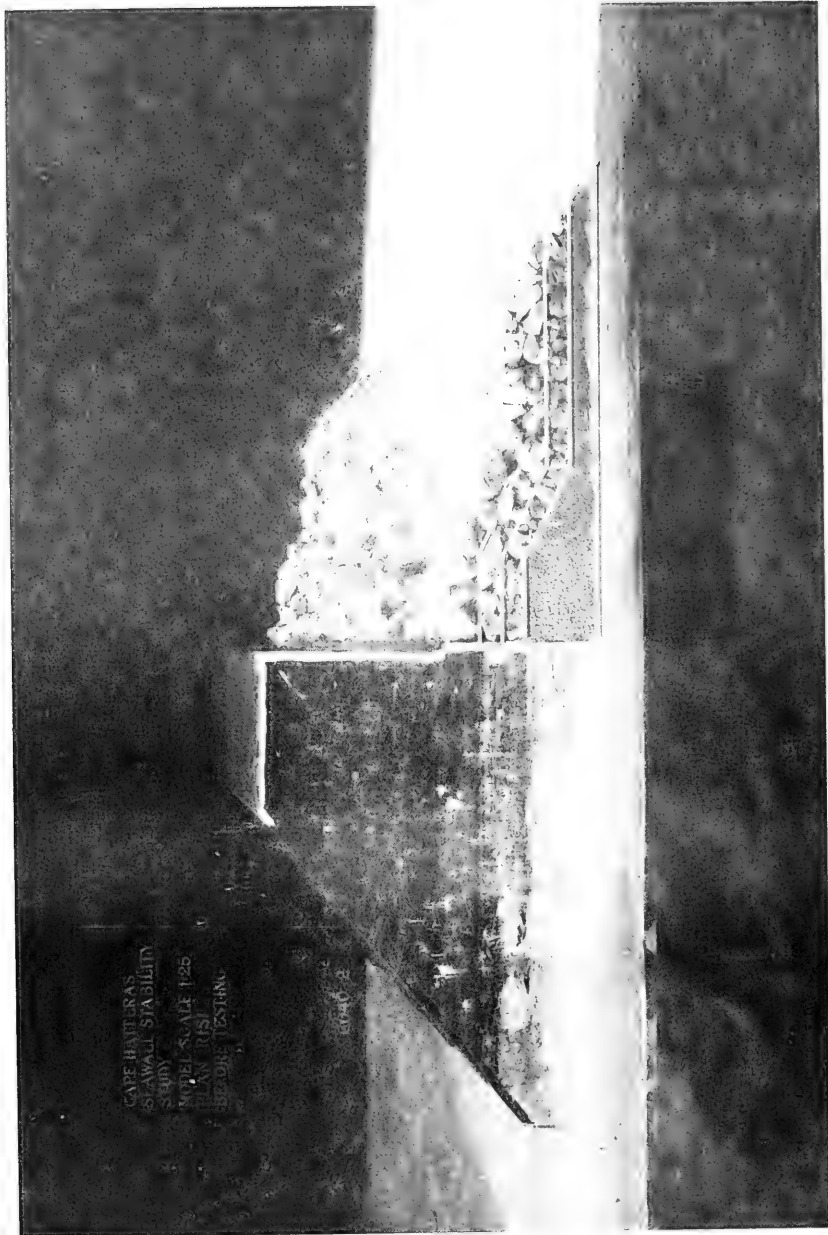

Photo 2. End view of Plan R1S1 before testing

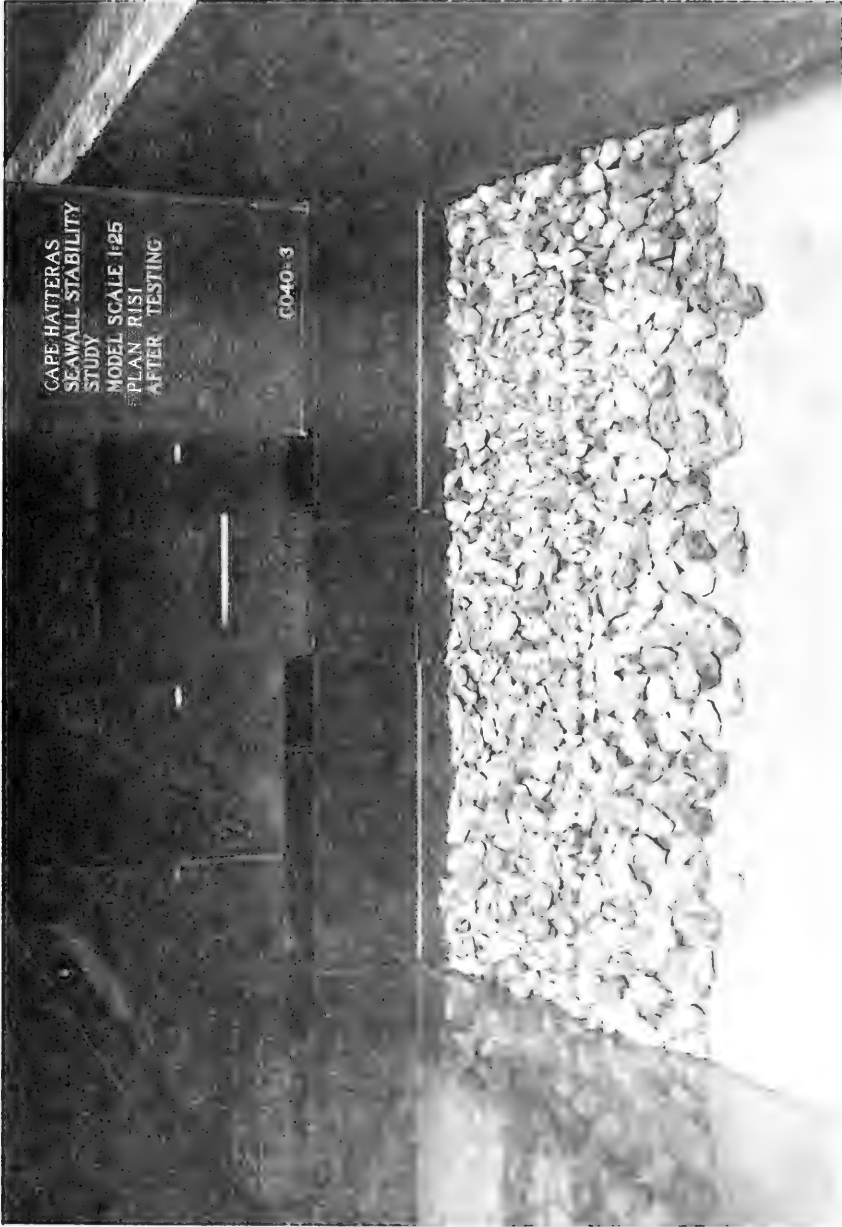

Photo 3. Sea-side view of Plan RIS1 after testing with the abbreviated storm-surge hydrograph

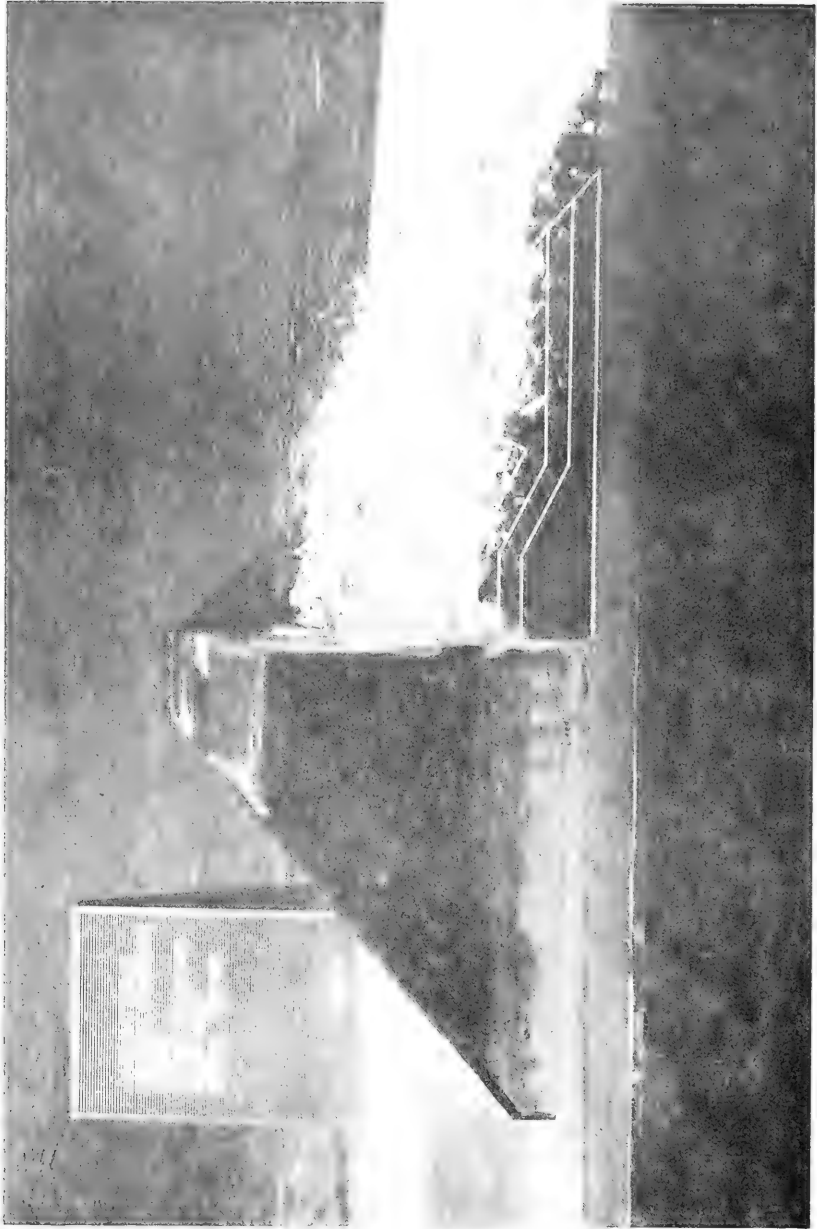

Photo 4. End view of Plan R1S1 after testing with the abbreviated storm-surge hydrograph



Photo 5. Sea-side view of Plan R2S1 before testing

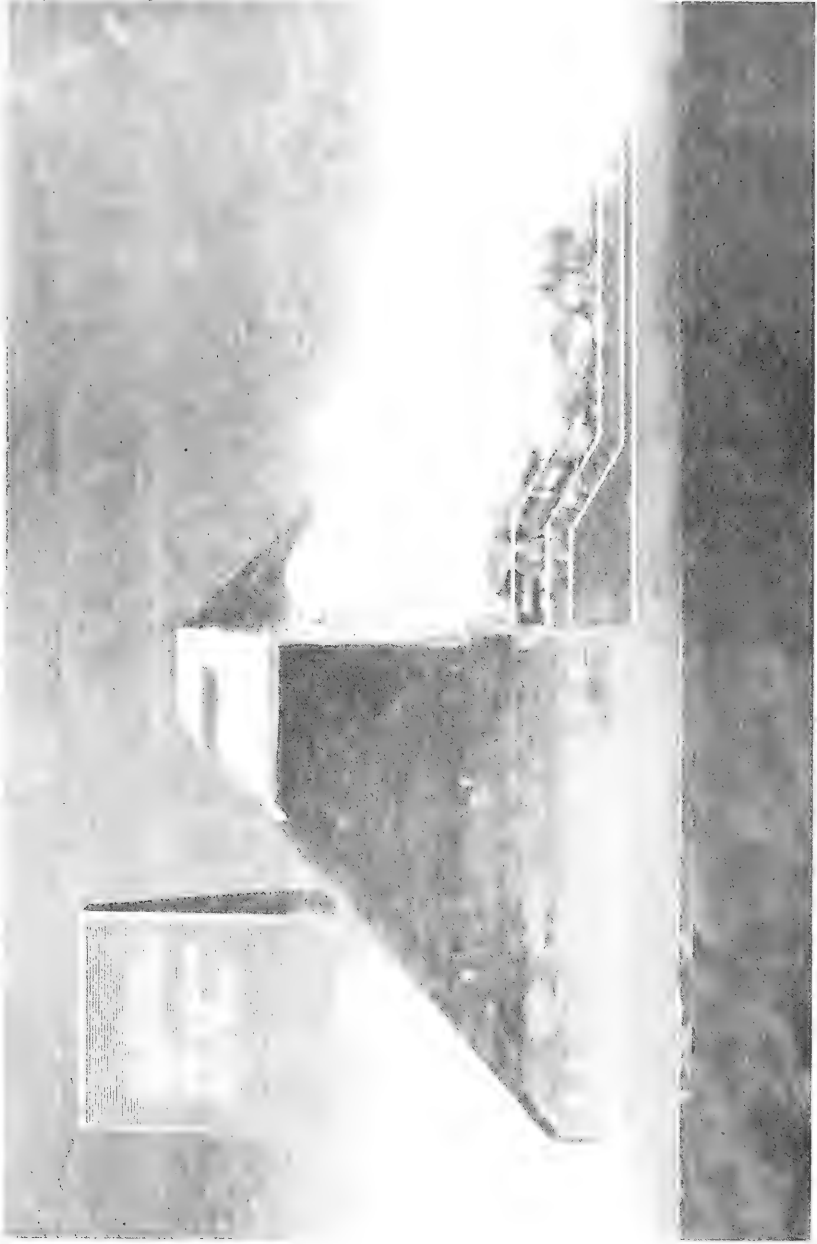

Photo 6. End view of Plan R2S1 before testing

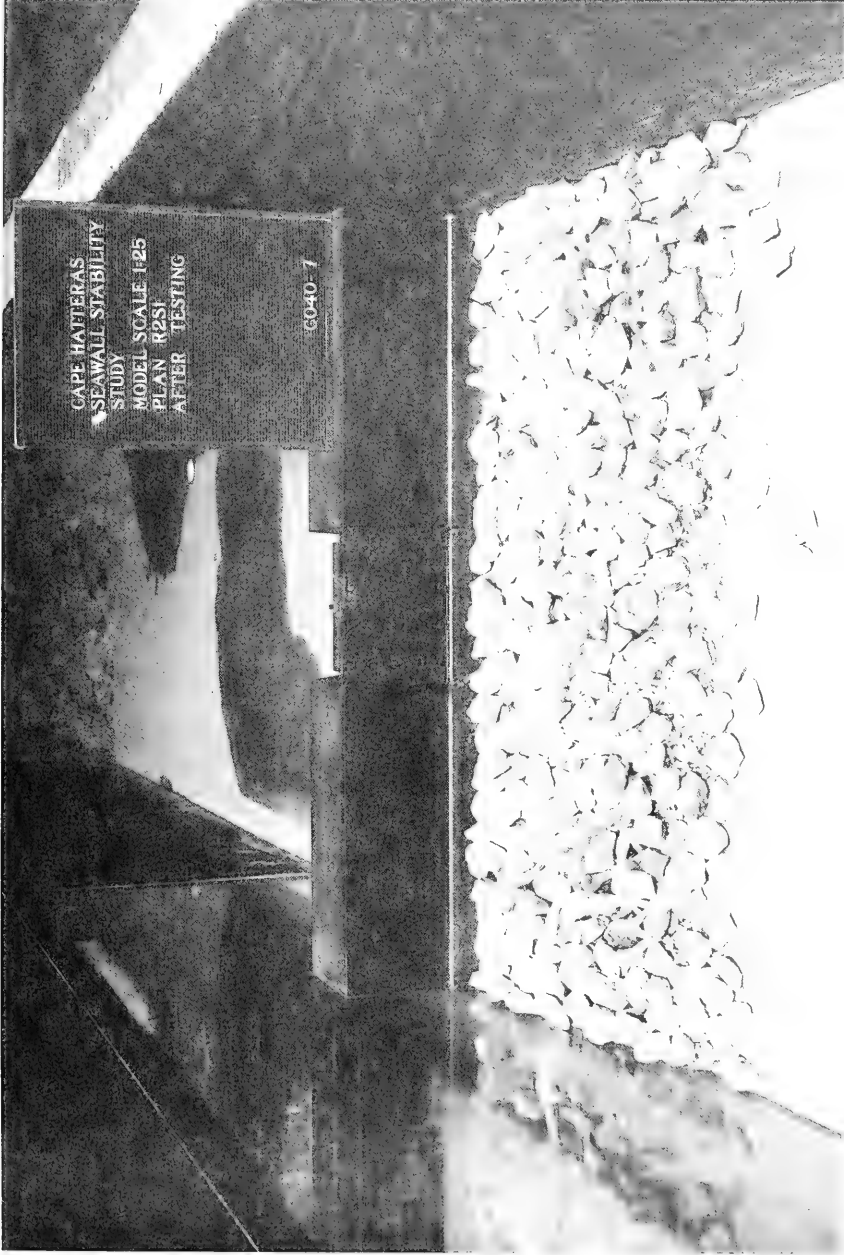

Photo 7. Sea-side view of Plan R2S1 after testing with the abbreviated storm-surge hydrograph



Photo 8. End view of Plan R2S1 after testing with the abbreviated storm-surge hydrograph

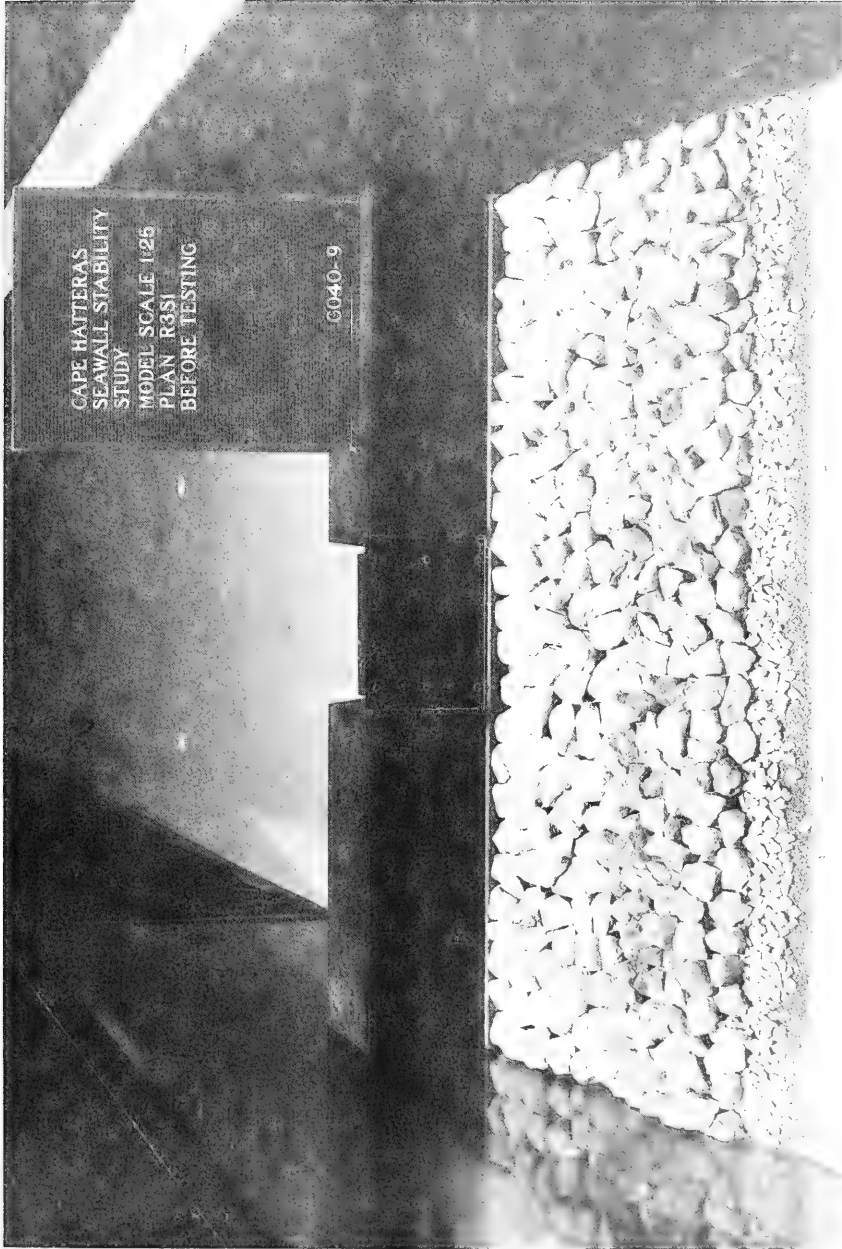
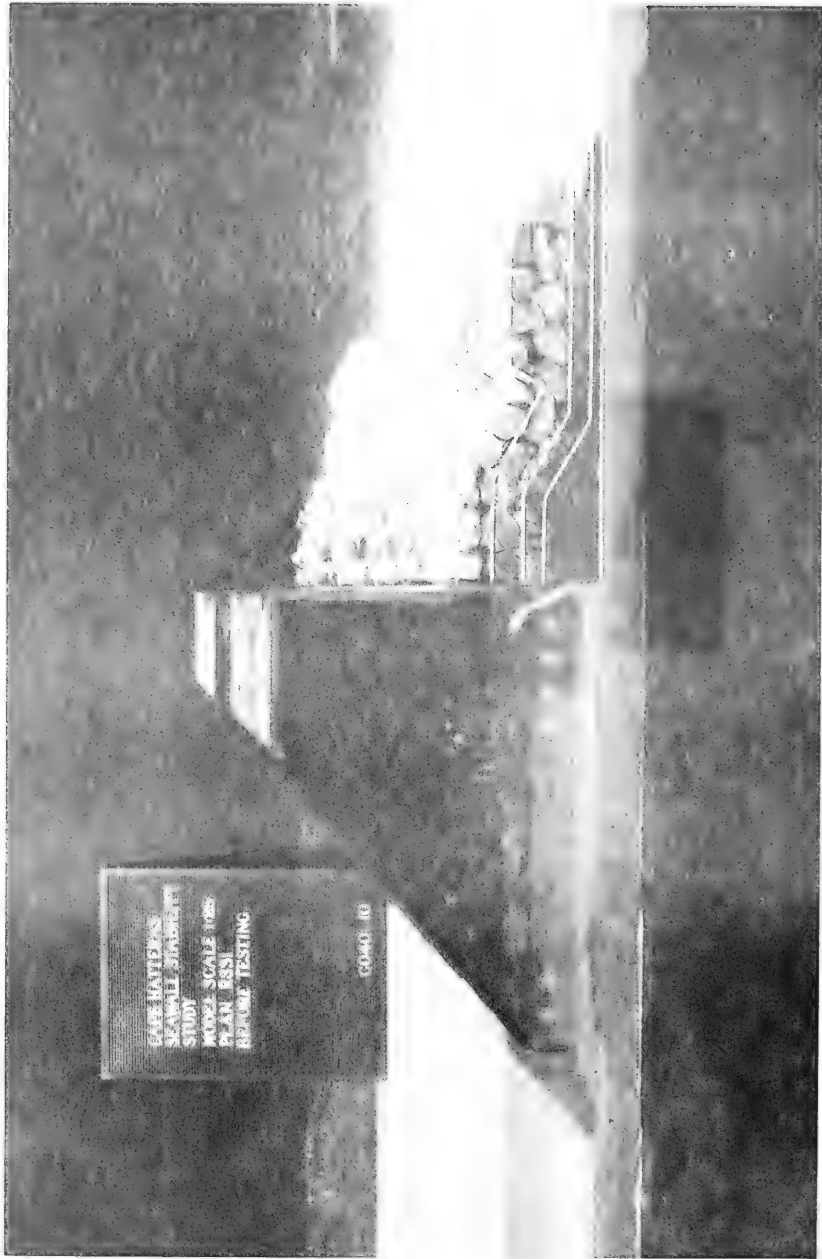

Photo 9. Sea-side view of Plan R3S1 before testing



LAKE HATFIELD
SEAWALL STABILITY
STUDY
MOORE SCALE 1/800
PLAN BSS1
BEFORE TESTING
C04010

Photo 10. End view of Plan R3S1 before testing

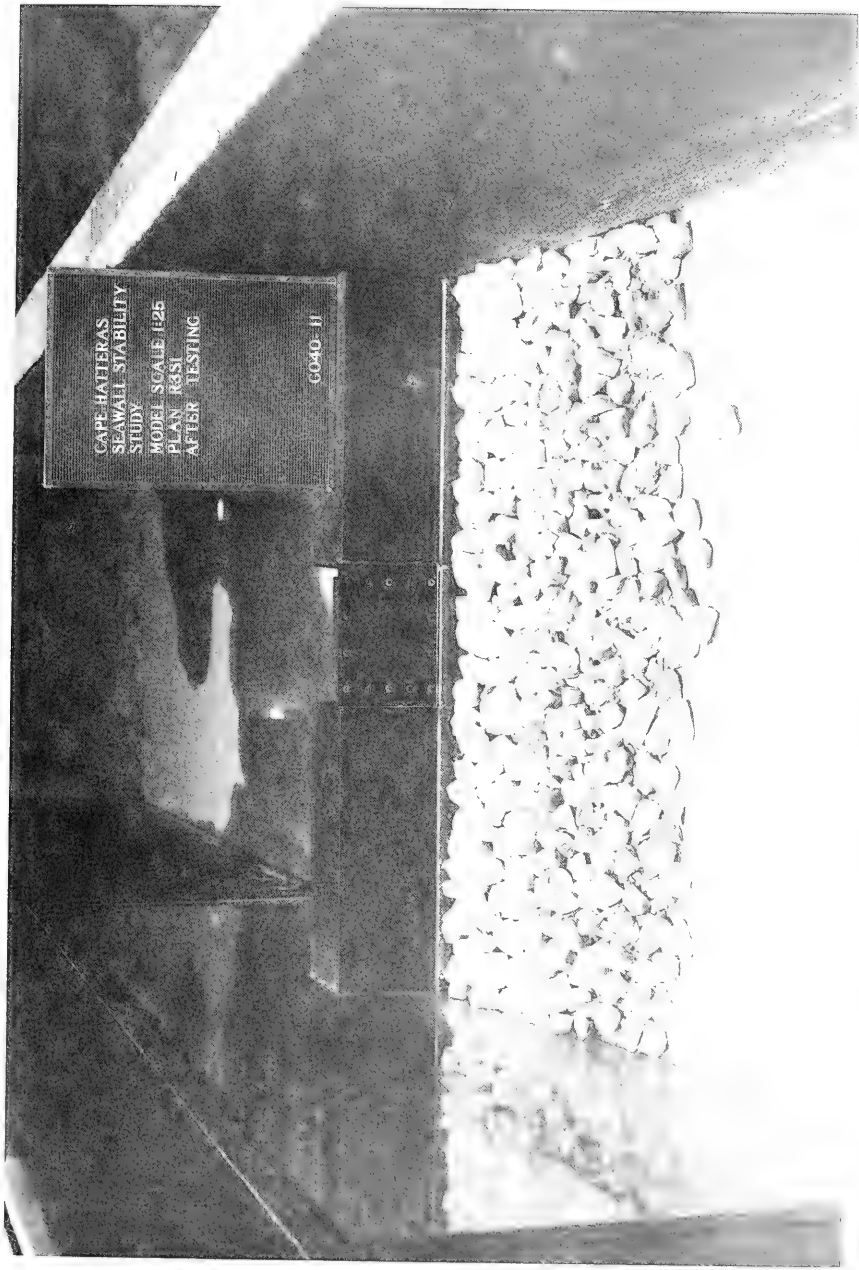

Photo 11. Sea-side view of Plan R3S1 after testing with the abbreviated storm-surge hydrograph

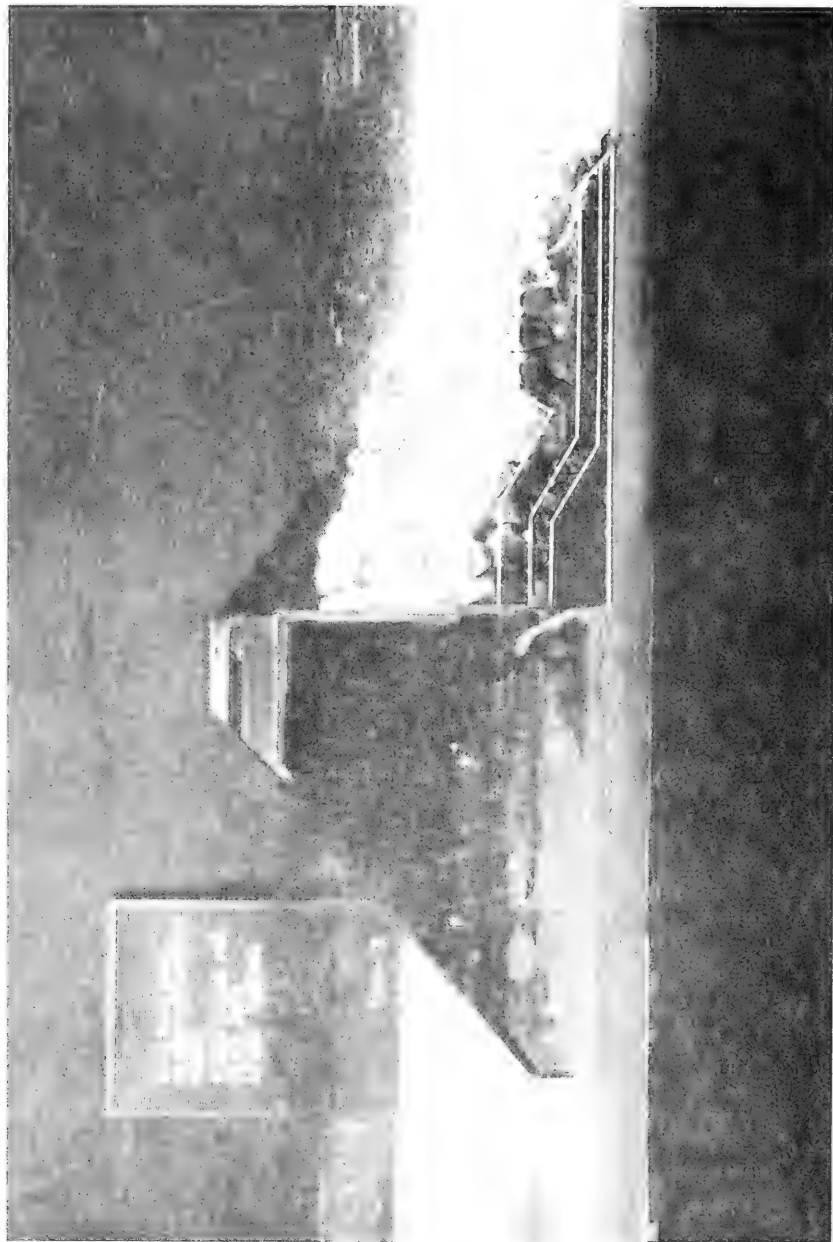

Photo 12. End view of Plan R3S1 after testing with the abbreviated storm-surge hydrograph



CAPE HATTERAS
SEAWALL STABILITY
STUDY
MODEL SCALE 1:25
PLAN R4SI
BEFORE TESTING

G040-113

Photo 13. Sea-side view of Plan R4SI before testing

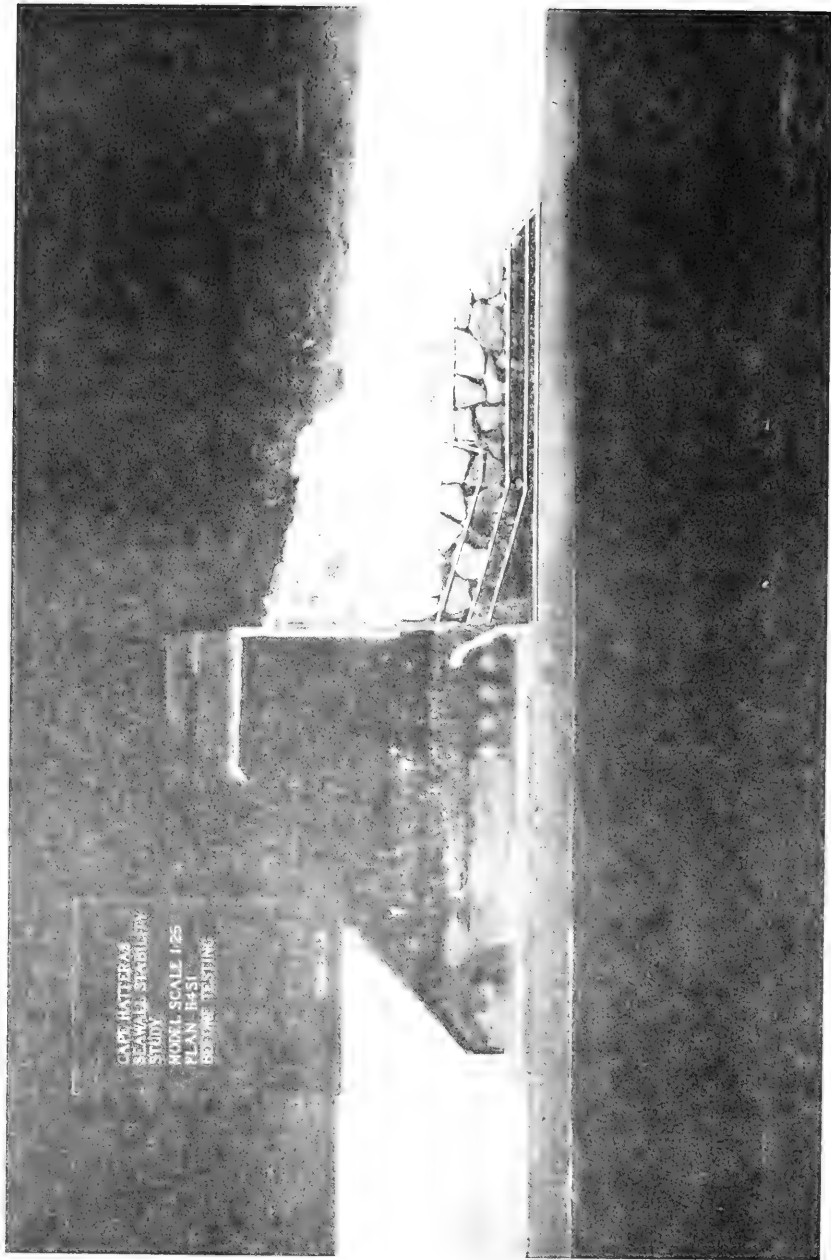

Photo 14. End view of Plan R4S1 before testing

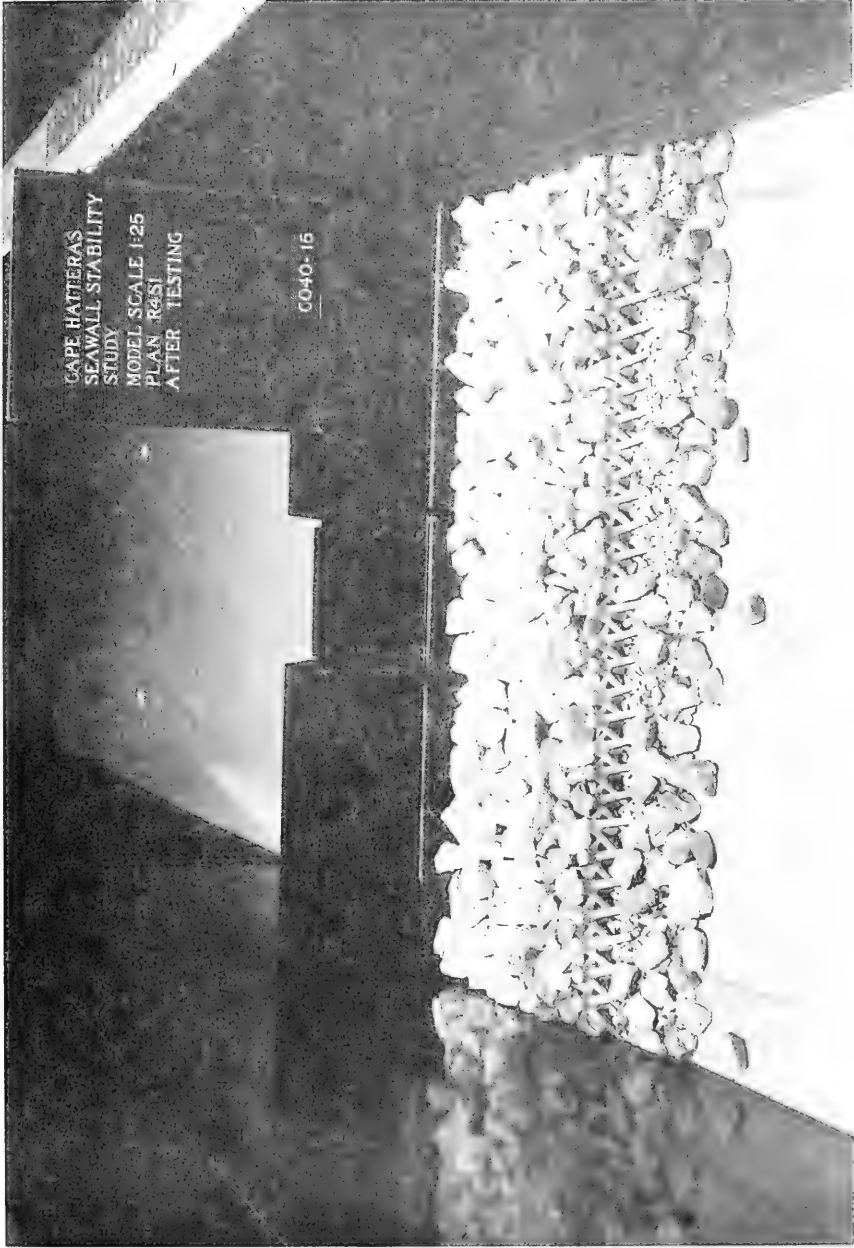
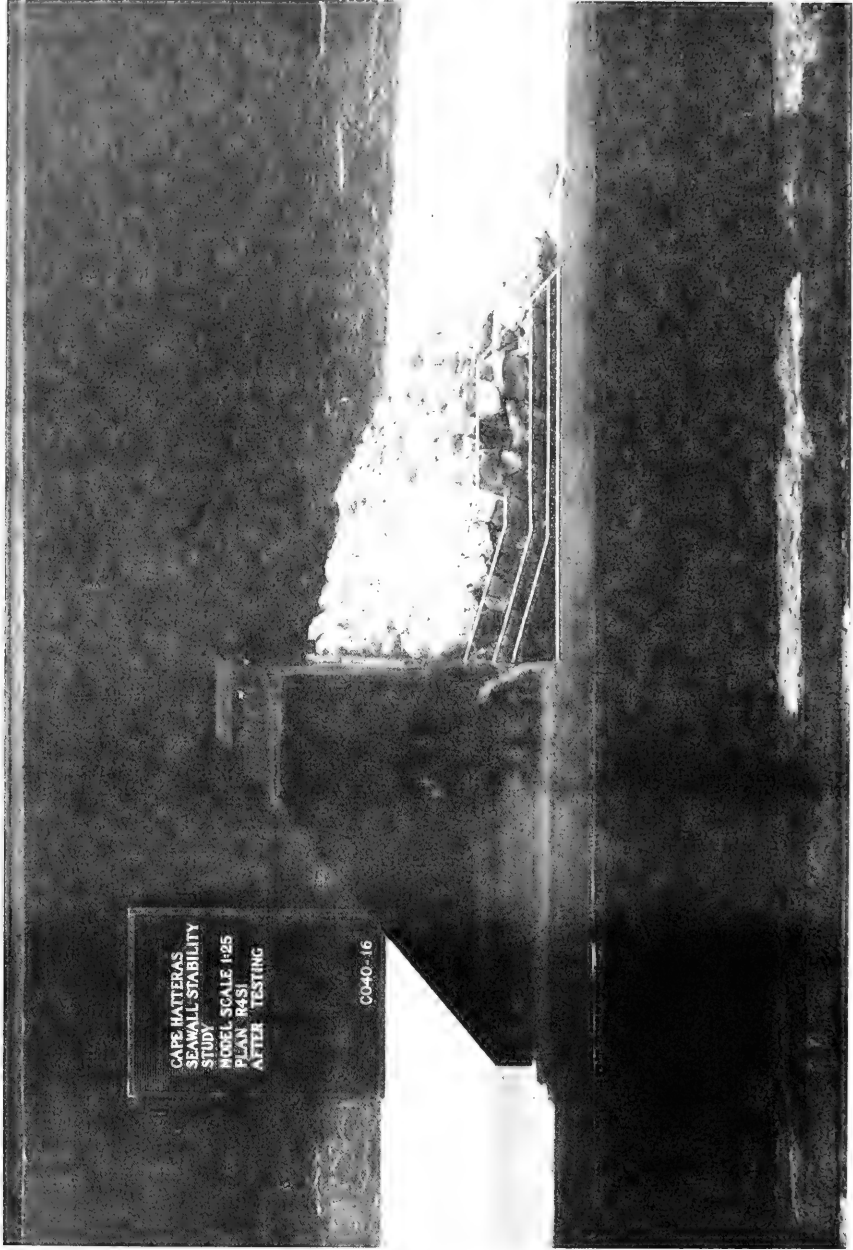

Photo 15. Sea-side view of Plan R4S1 after testing with the abbreviated storm-surge hydrograph



CAPE HATTERAS
SEAWALL STABILITY
STUDY
MODEL SCALE 1:25
PLAN R4S1
AFTER TESTING

C040-16

Photo 16. End view of Plan R4S1 after testing with the abbreviated storm-surge hydrograph

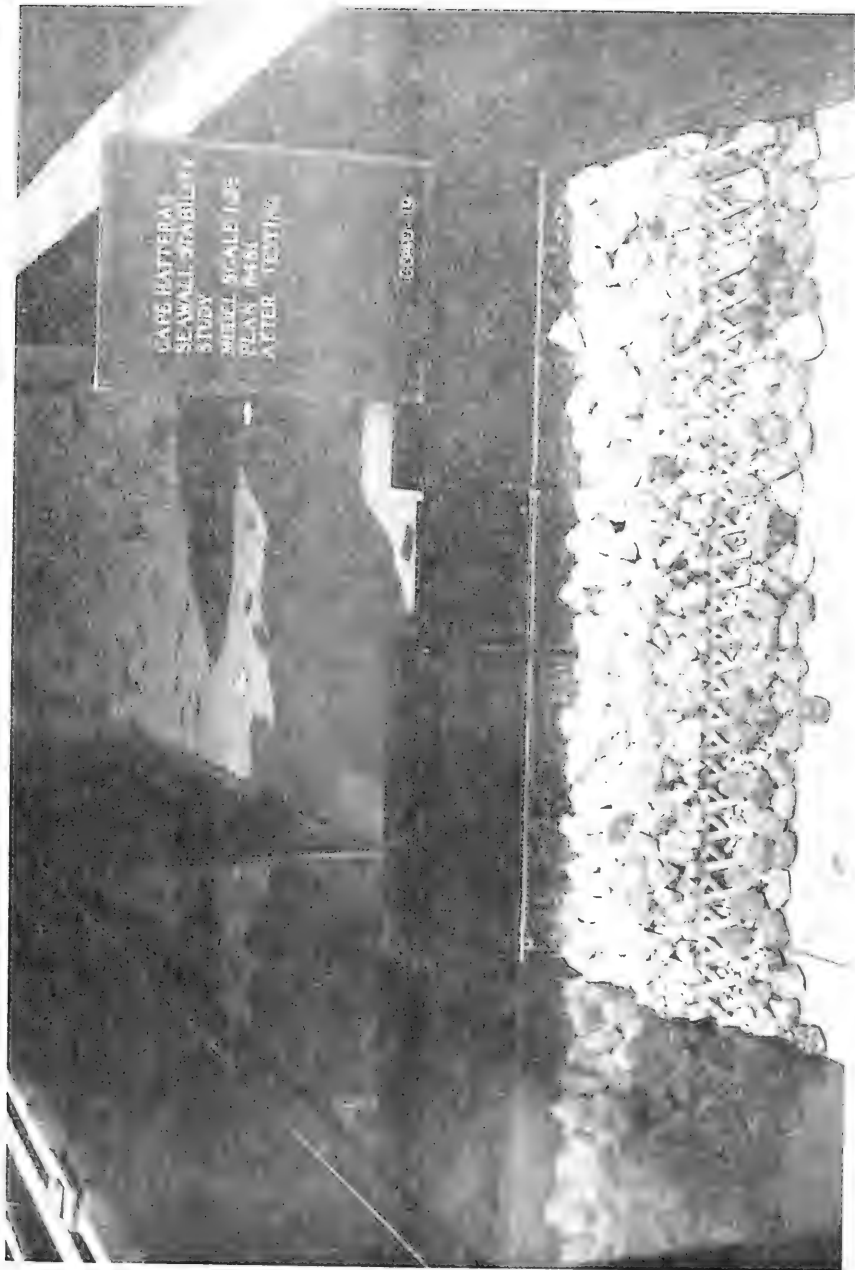

Photo 17. Sea-side view of Plan R4S1 after testing with the 13-hr storm-surge hydrograph

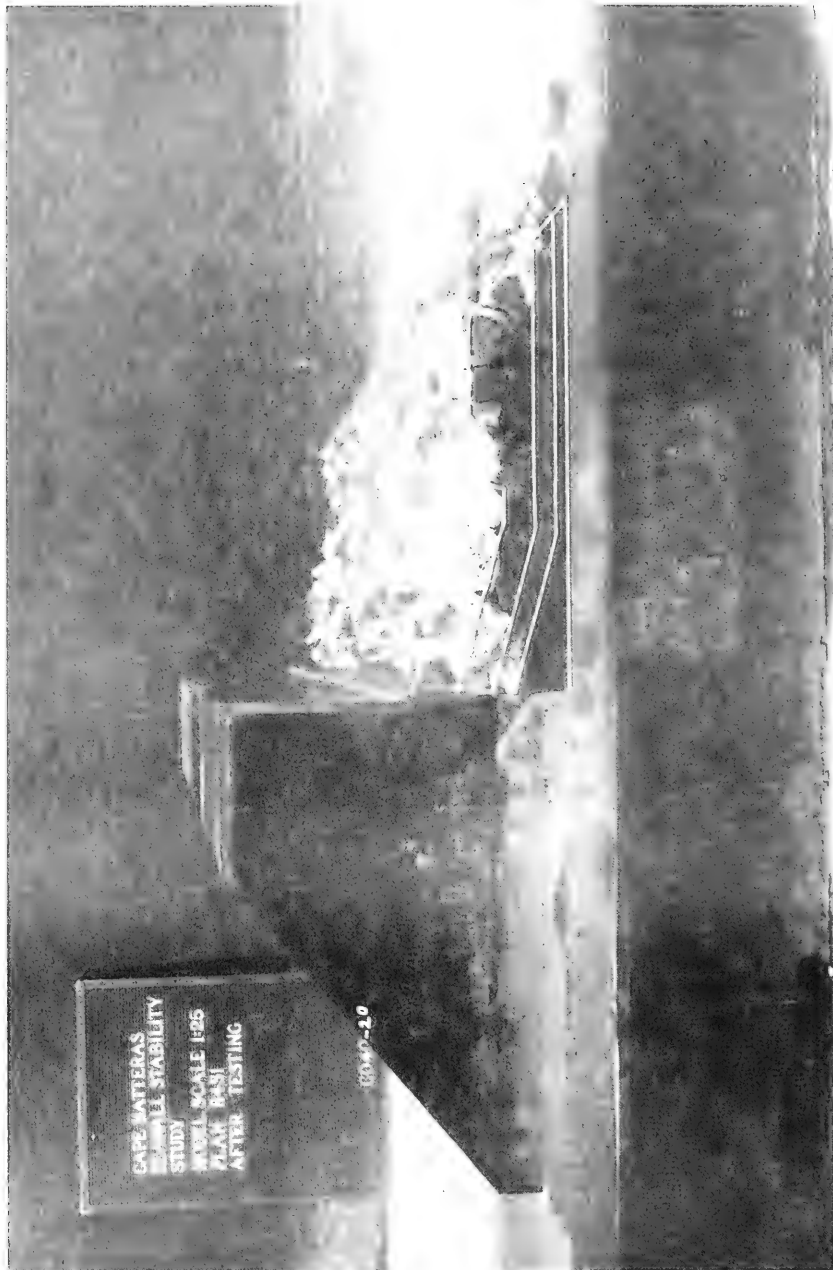

Photo 18. End view of Plan R4S1 after testing with the 13-hr storm-surge hydrograph

CAPE HATTERAS
SEAWALL STABILITY
STUDY
MODEL SCALE 1/25
PLAN R4S2
BEFORE TESTING

CG40. 21



Photo 19. Sea-side view of Plan R4S2 before testing

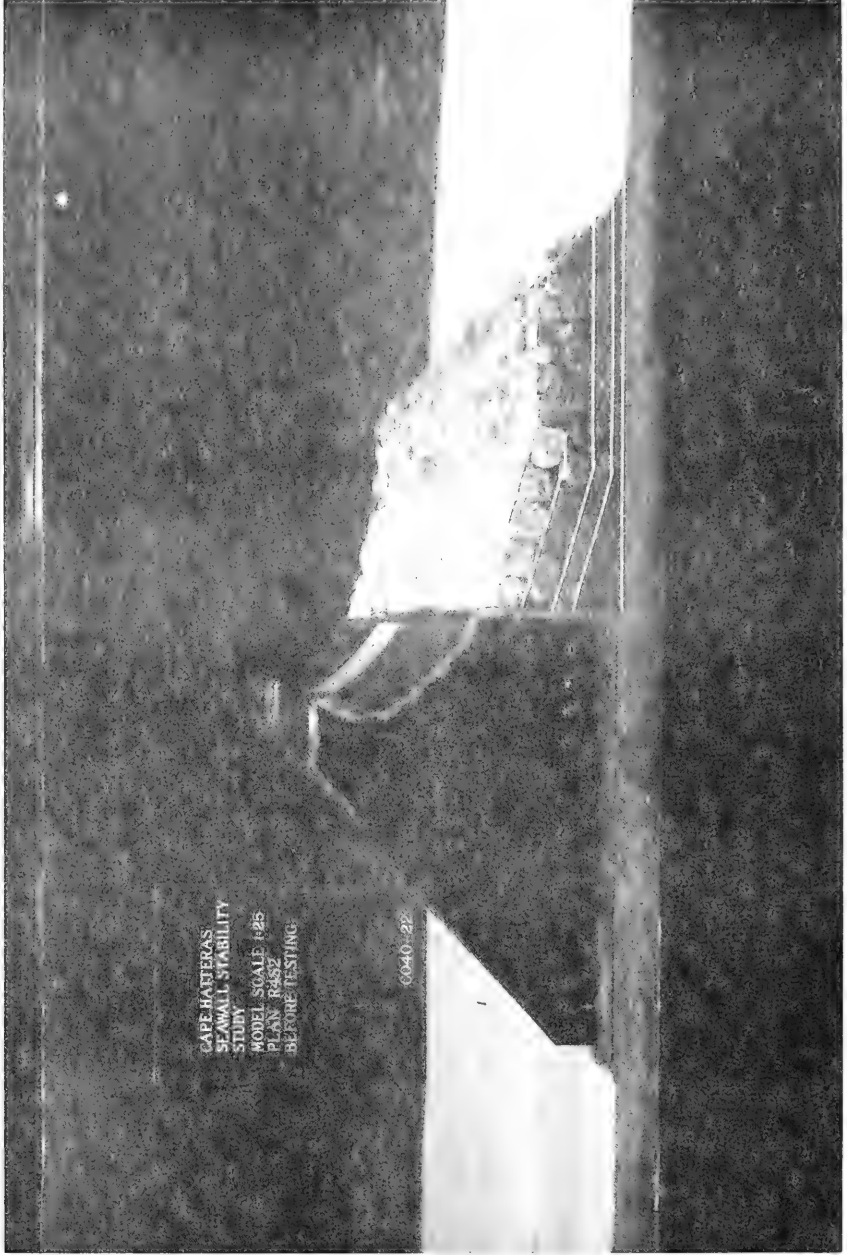

Photo 20. End view of Plan R4S2 before testing

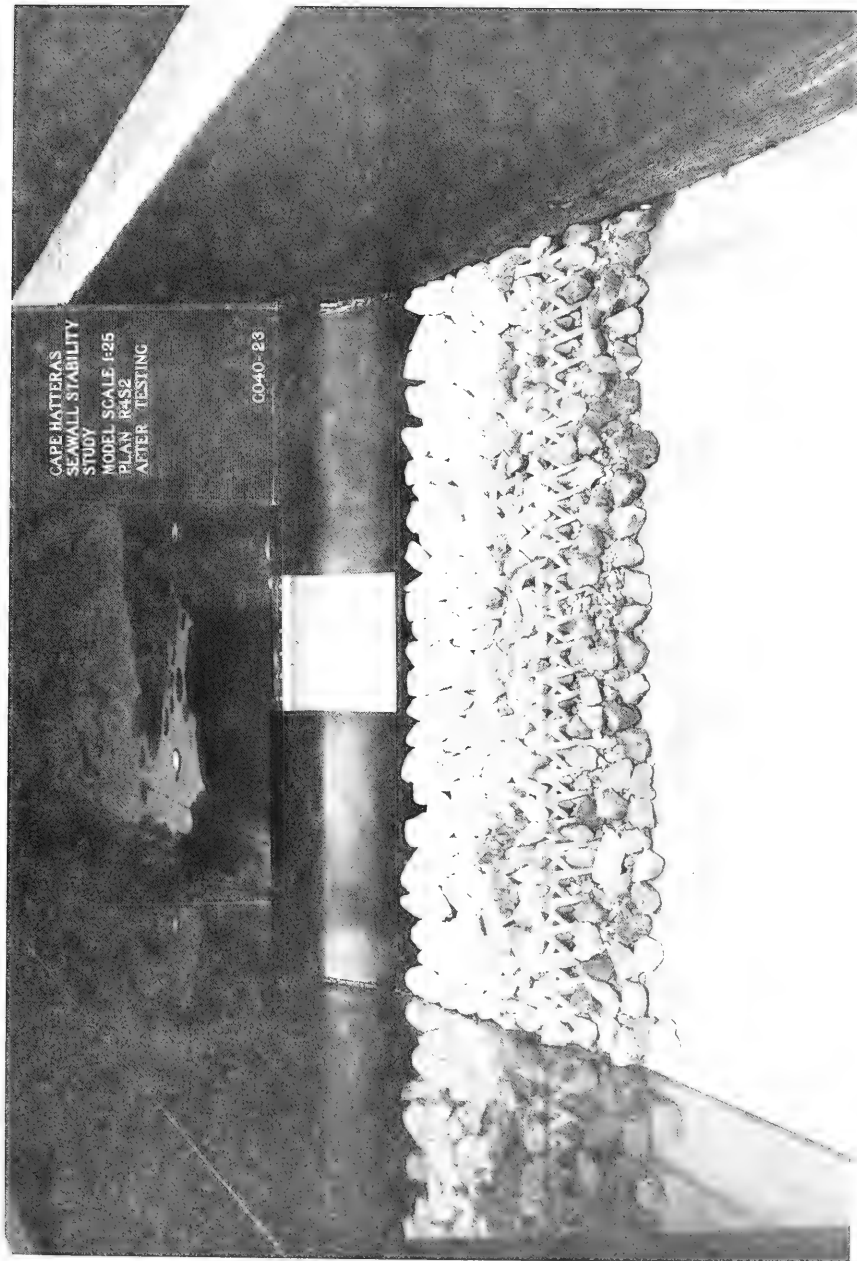

Photo 21. Sea-side view of Plan R4S2 after testing with the abbreviated storm-surge hydrograph

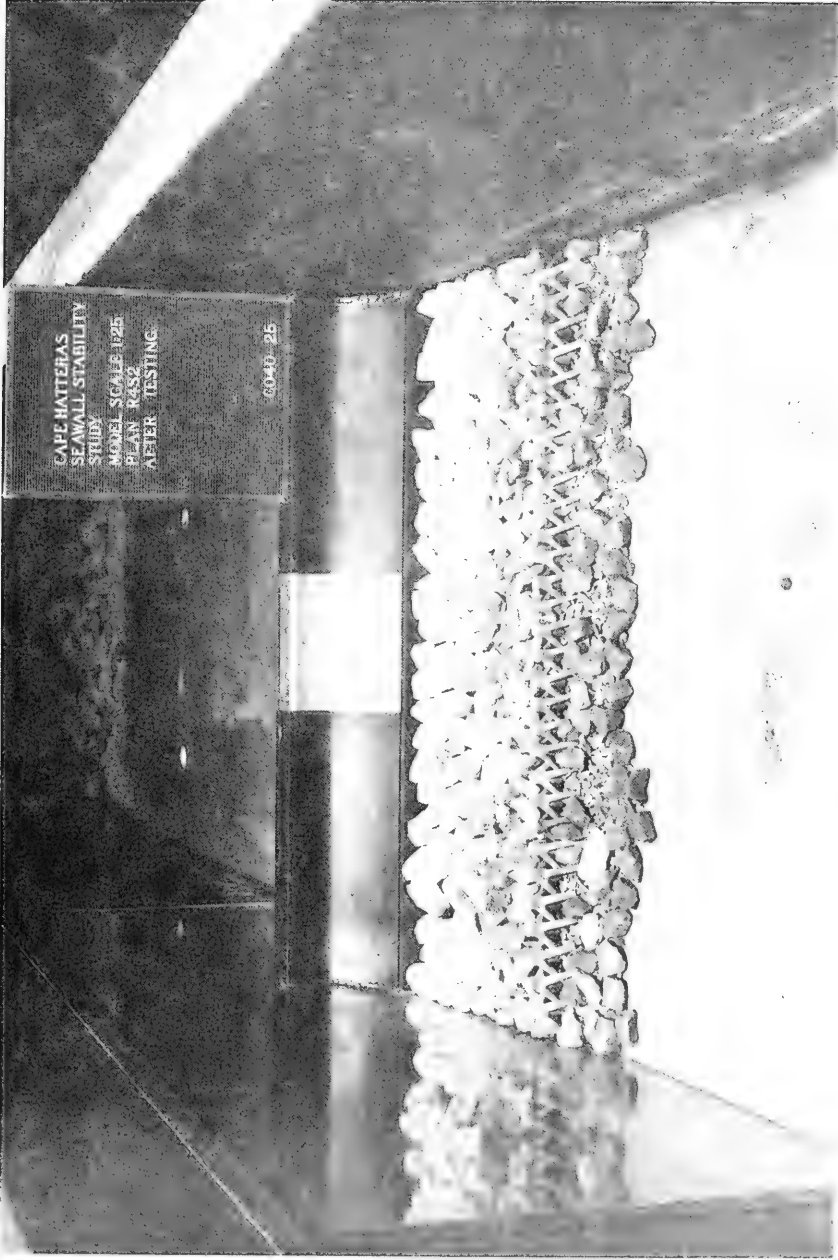

Photo 23. Sea-side view of Plan R4S2 after testing step 4 of the 13-hr storm-surge hydrograph

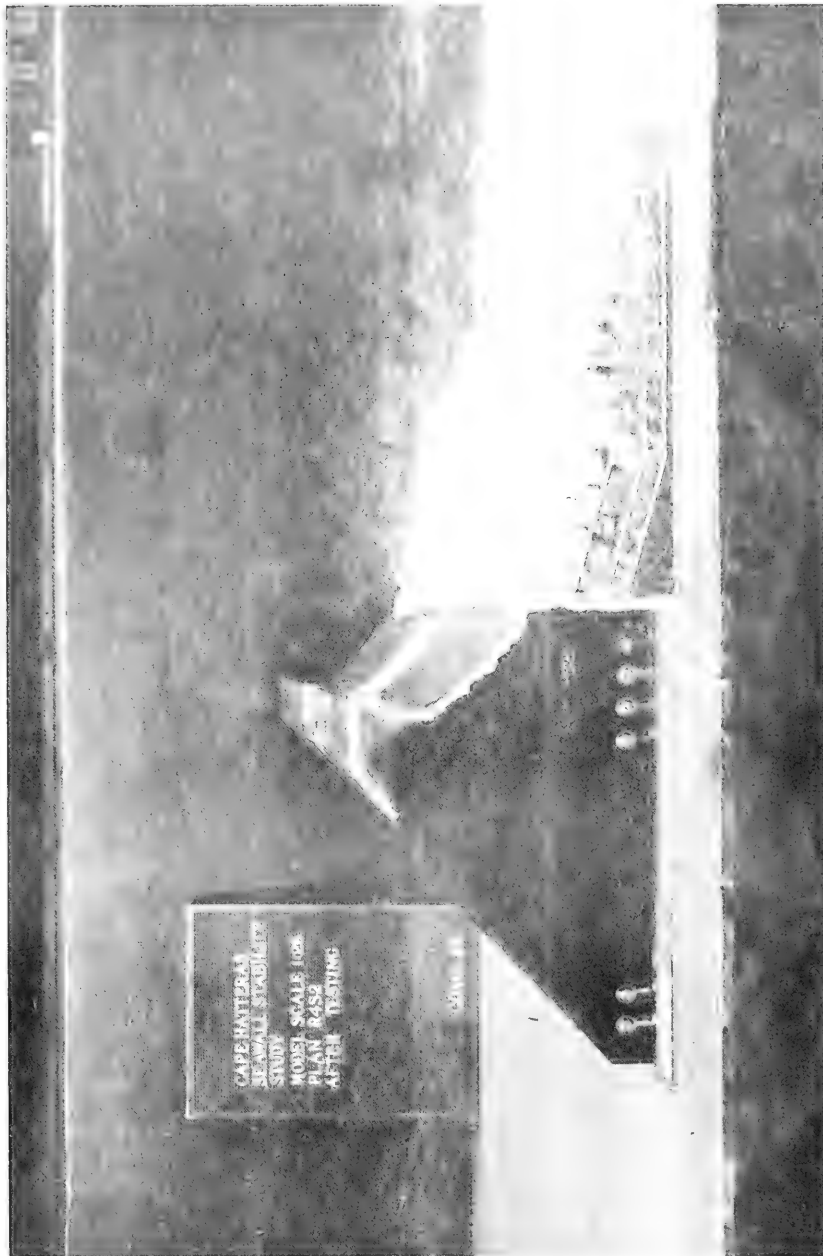

Photo 24. End view of Plan R4S2 after testing step 4 of the 13-hr storm-surge hydrograph

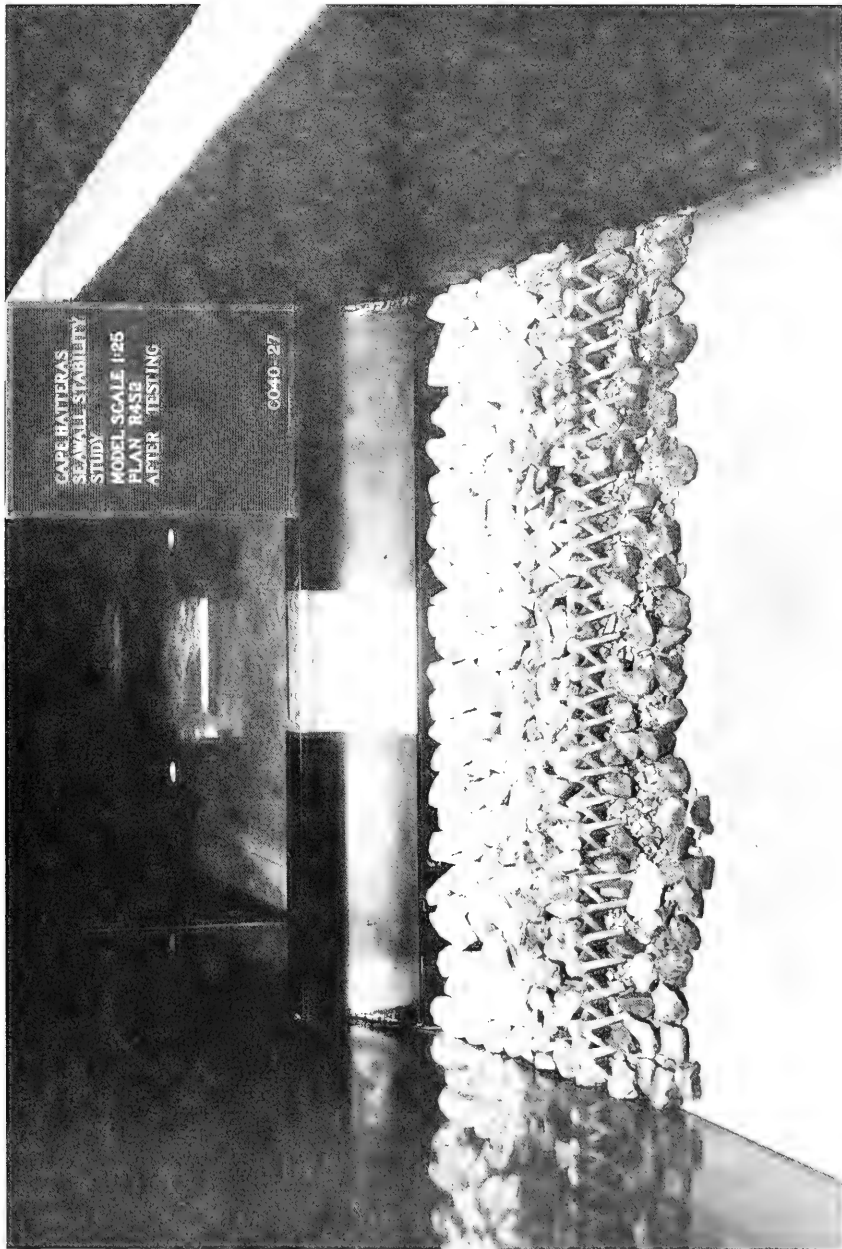

Photo 25. Sea-side view of Plan R4S2 after testing with the 13-hr storm-surge hydrograph

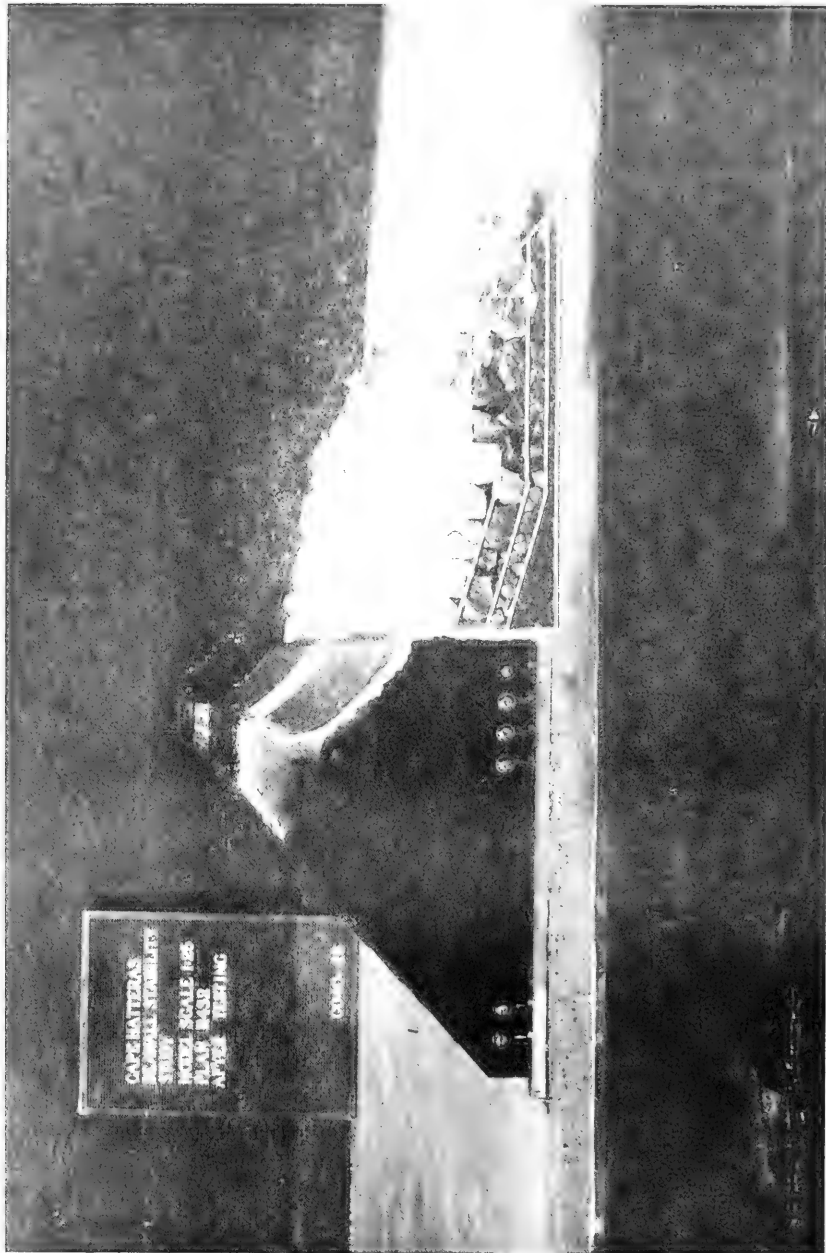

Photo 26. End view of Plan R4S2 after testing with the
13-hr storm-surge hydrograph

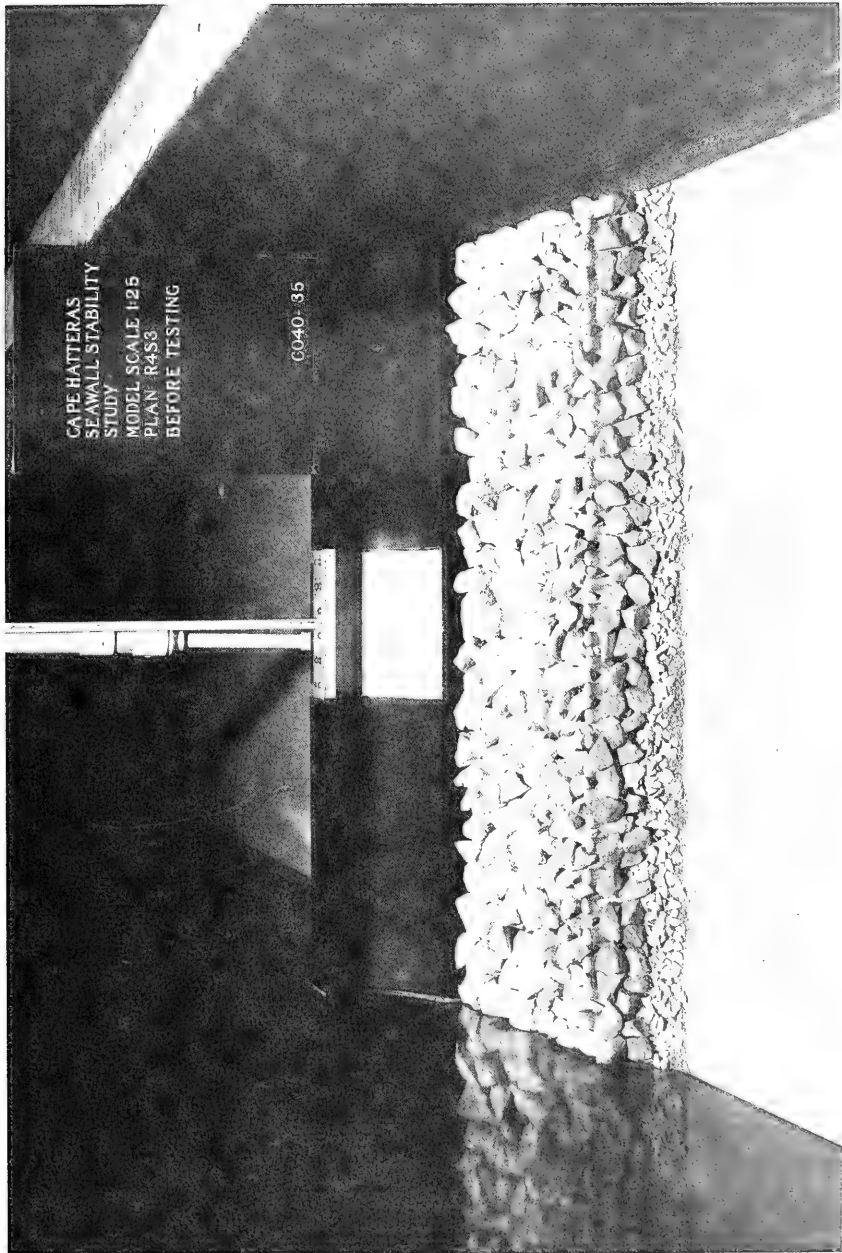
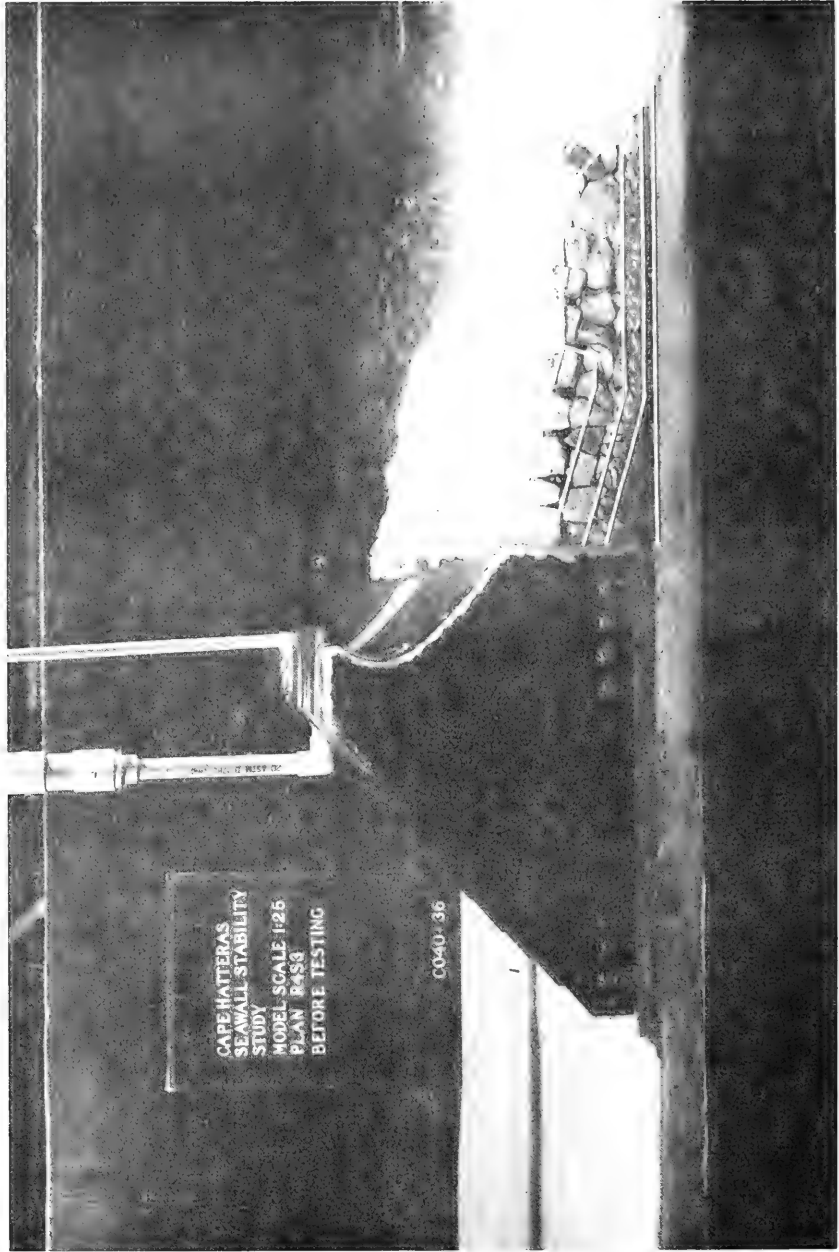

Photo 27. Sea-side view of Plan R4S3 before testing



CAPE HATTERAS
SEAWALL STABILITY
STUDY
MODEL SCALE 1:26
PLAN R4S3
BEFORE TESTING

C040-36

Photo 28. End view of Plan R4S3 before testing



Photo 29. Sea-side view of Plan R4S3 after testing with the abbreviated and 13-hr storm-surge hydrographs

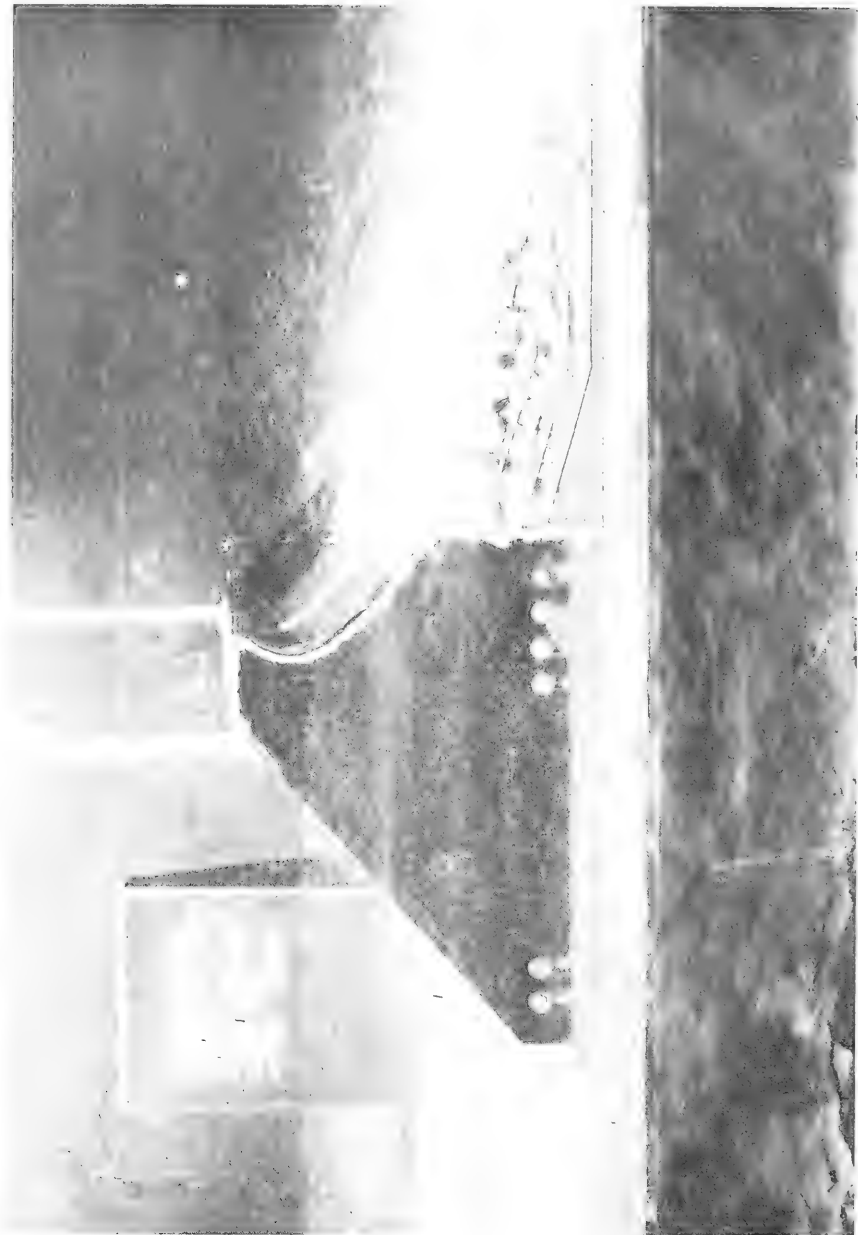
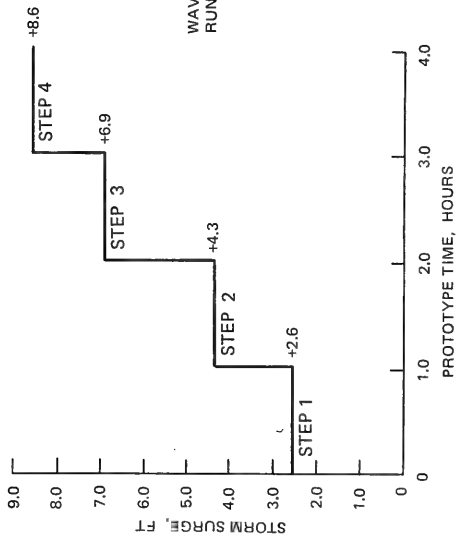

Photo 30. End view of Plan R4S3 after testing with the abbreviated and 13-hr storm-surge hydrographs



WAVE PERIODS OF 6, 8, 10 AND 12 SEC WERE
RUN AT EACH STEP (15 MIN PER PERIOD)

ABBREVIATED STORM SURGE HYDROGRAPH

STEP	SWL, FT	DURATION, HR
1	2.6	1.3
2	4.3	2.5
3	6.9	2.2
4	8.6	2.9
5	6.9	1.4
6	4.3	1.5
7	2.6	0.8

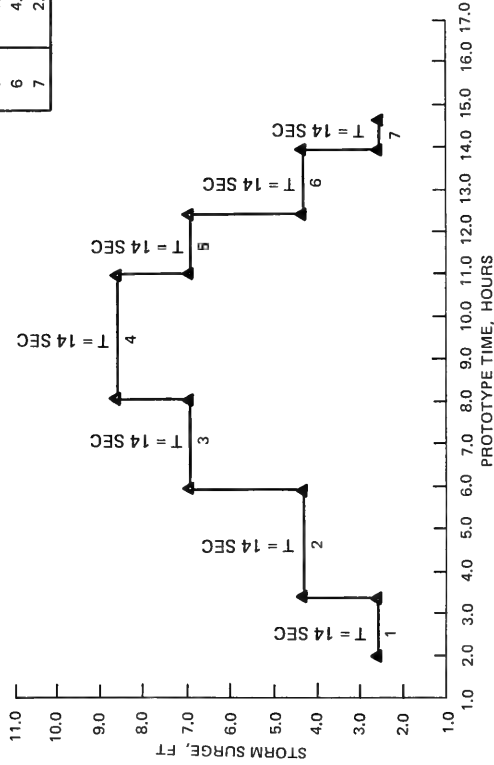

13-HOUR STORM SURGE HYDROGRAPH
 MAXIMUM WAVE PERIOD = 14 SEC

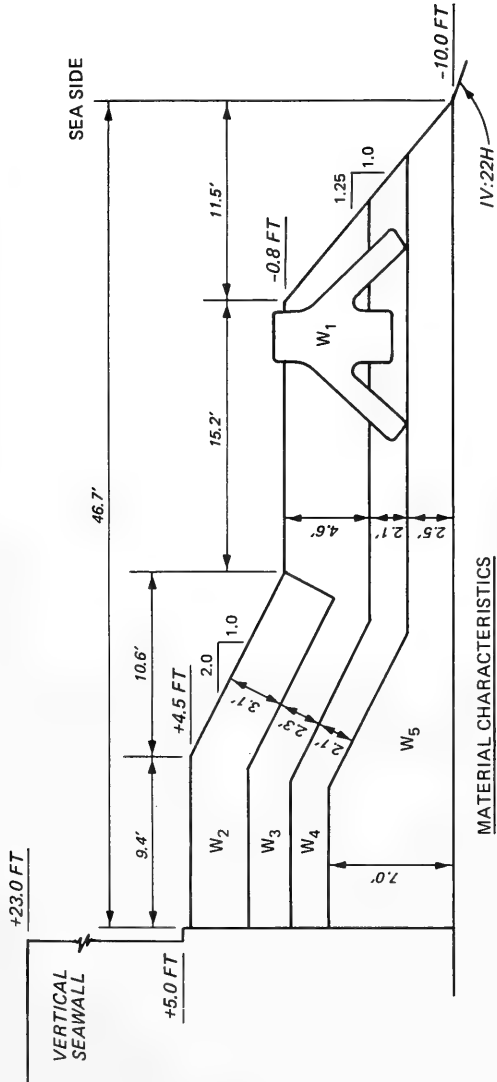

MATERIAL CHARACTERISTICS

MODEL

PROTOTYPE

$W_1 = 0.37\text{-LB STAPODS AT } 167 \text{ PCF}$	$W_1 = 5.0\text{-TON STAPODS AT } 150 \text{ PCF}$
$W_2 = 0.28\text{-LB STONE AT } 165 \text{ PCF}$	$W_2 = 2.5\text{-TON STONE AT } 165 \text{ PCF}$
$W_3 = 0.11\text{-LB STONE AT } 165 \text{ PCF}$	$W_3 = 1.0\text{-TON STONE AT } 165 \text{ PCF}$
$W_4 = 0.01\text{-LB STONE AT } 165 \text{ PCF}$	$W_4 = 150\text{-LB STONE AT } 125 \text{ PCF}$
$W_5 = 0.001\text{-LB STONE AT } 165 \text{ PCF}$	$W_5 = 2\text{-TO-60 LB STONE AT } 125 \text{ PCF}$

TYPICAL REVETMENT CROSS SECTION
 PLAN R1S1
 MODEL SCALE 1:25

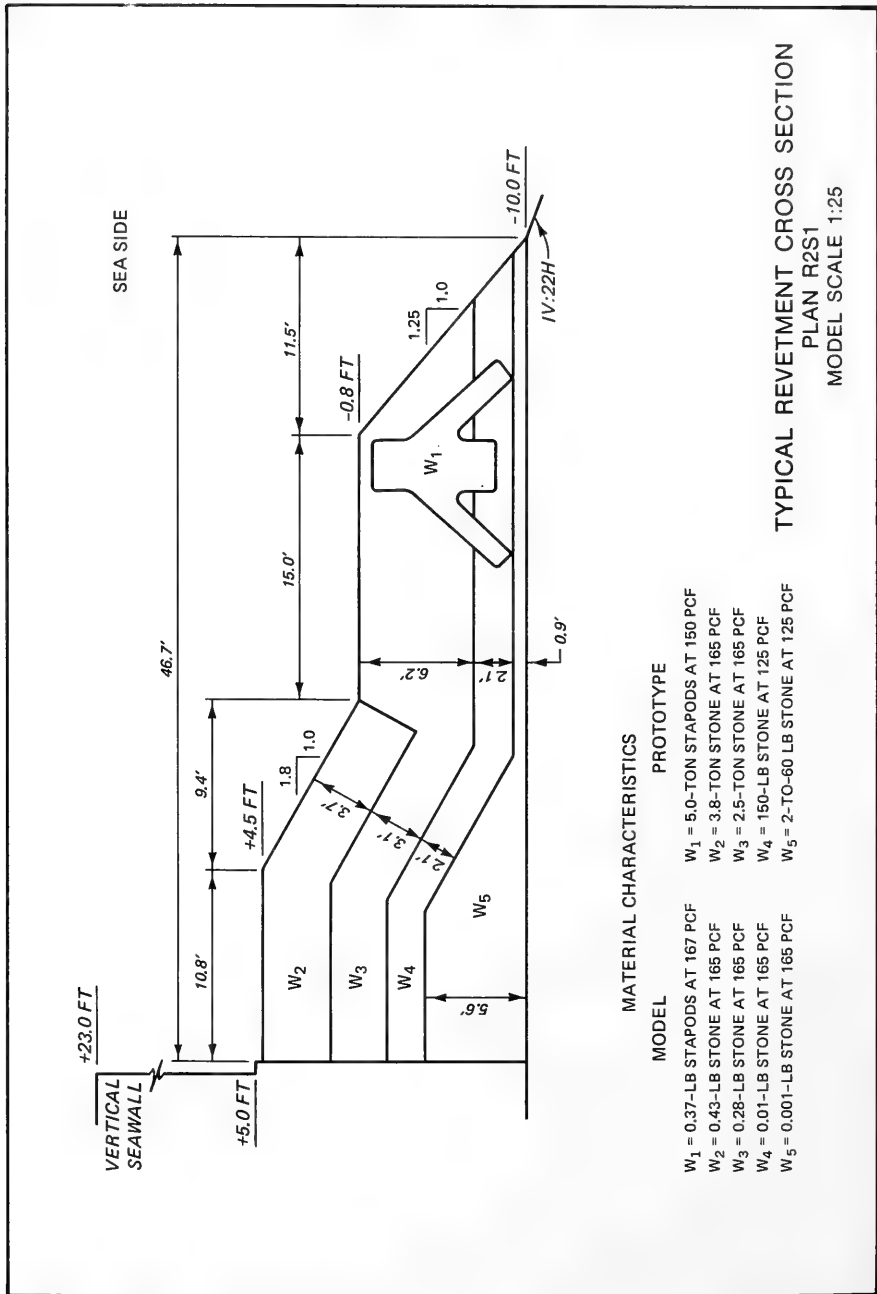

SEA SIDE

VERTICAL SEAWALL

+23.0 FT

+5.0 FT

10.8'

9.4'

46.7'

4.5 FT

1.8

3.1'

2.7'

2.7'

W2

W3

W4

W5

15.0'

11.5'

1.25

1.0

W1

-0.8 FT

6.2'

2.1'

0.9'

IV:22H

-10.0 FT

MATERIAL CHARACTERISTICS

MODEL PROTOTYPE

- W₁ = 0.37-LB STAPDS AT 167 PCF
- W₂ = 0.43-LB STONE AT 165 PCF
- W₃ = 0.28-LB STONE AT 165 PCF
- W₄ = 0.01-LB STONE AT 165 PCF
- W₅ = 0.001-LB STONE AT 165 PCF
- W₁ = 5.0-TON STAPDS AT 150 PCF
- W₂ = 3.8-TON STONE AT 165 PCF
- W₃ = 2.5-TON STONE AT 165 PCF
- W₄ = 150-LB STONE AT 125 PCF
- W₅ = 2-TO-60 LB STONE AT 125 PCF

TYPICAL REVETMENT CROSS SECTION
 PLAN R2S1
 MODEL SCALE 1:25

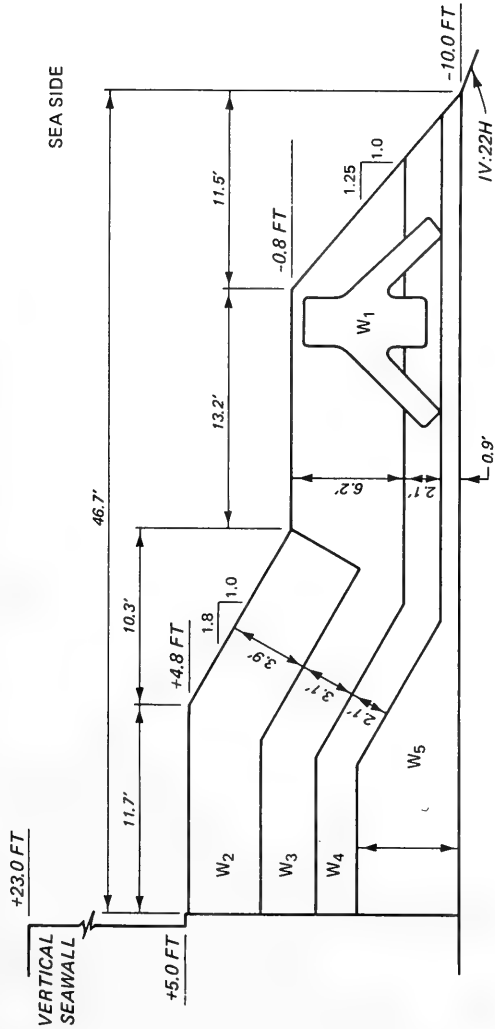

MATERIAL CHARACTERISTICS

MODEL PROTOTYPE

W ₁ = 0.37-LB STAPODS AT 167 PCF	W ₁ = 5.0-TON STAPODS AT 150 PCF
W ₂ = 0.55-LB STONE AT 165 PCF	W ₂ = 4.9-TON STONE AT 165 PCF
W ₃ = 0.28-LB STONE AT 165 PCF	W ₃ = 2.5-TON STONE AT 165 PCF
W ₄ = 0.01-LB STONE AT 165 PCF	W ₄ = 150-LB STONE AT 125 PCF
W ₅ = 0.001-LB STONE AT 165 PCF	W ₅ = 2-TO-60 LB STONE AT 125 PCF

TYPICAL REVETMENT CROSS SECTION
 PLAN R3S1
 MODEL SCALE 1:25

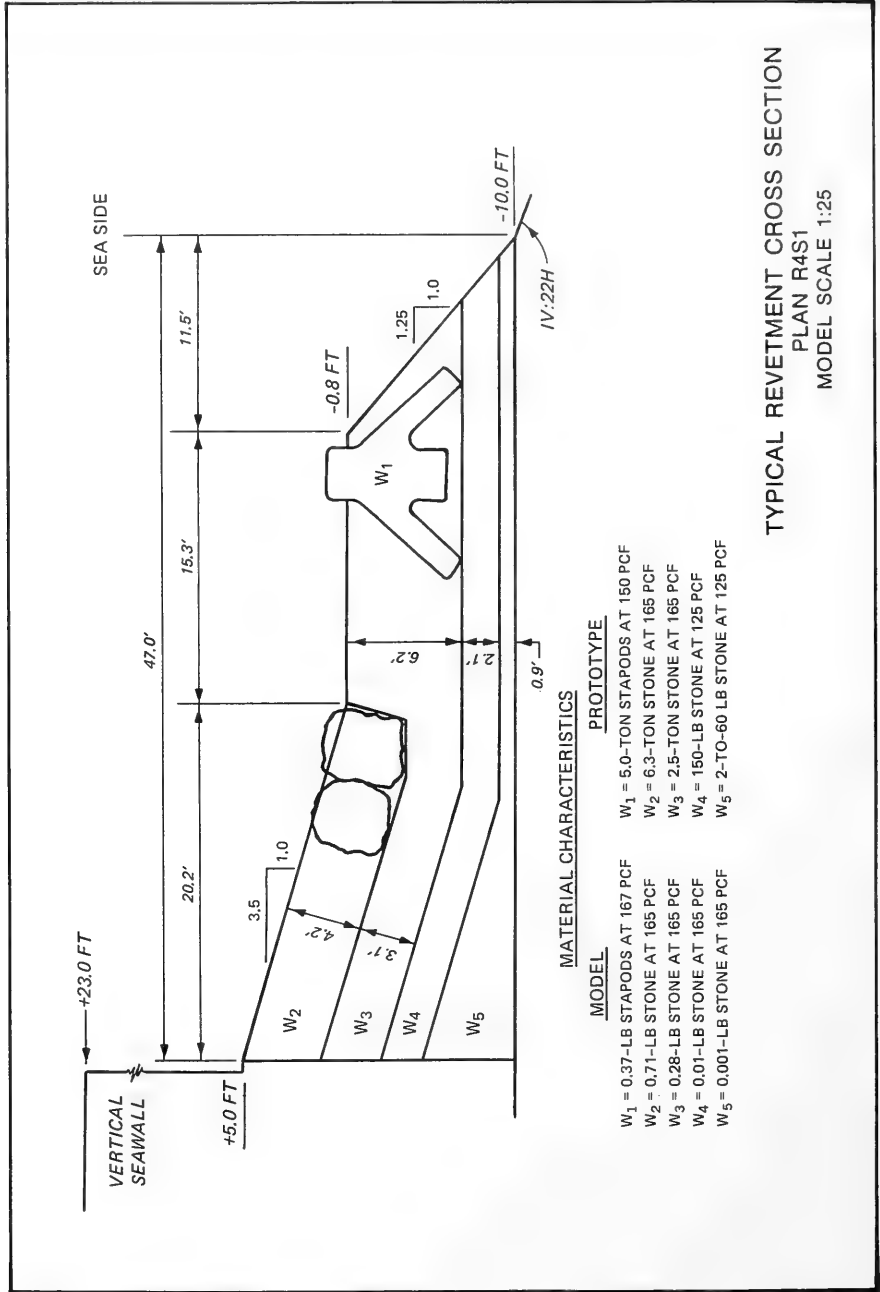

TYPICAL REVETMENT CROSS SECTION
 PLAN R4S1
 MODEL SCALE 1:25

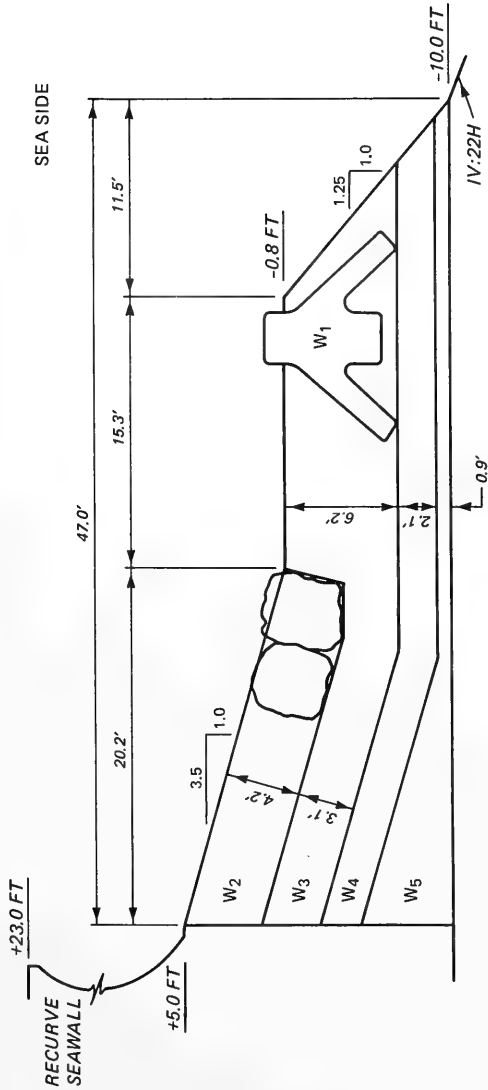

MATERIAL CHARACTERISTICS

MODEL PROTOTYPE

W ₁ = 0.37-LB STAPODS AT 167 PCF	W ₁ = 5.0-TON STAPODS AT 150 PCF
W ₂ = 0.71-LB STONE AT 165 PCF	W ₂ = 6.3-TON STONE AT 165 PCF
W ₃ = 0.28-LB STONE AT 165 PCF	W ₃ = 2.5-TON STONE AT 165 PCF
W ₄ = 0.01-LB STONE AT 165 PCF	W ₄ = 150-LB STONE AT 125 PCF
W ₅ = 0.001-LB STONE AT 165 PCF	W ₅ = 2-TO-60 LB STONE AT 125 PCF

**TYPICAL REVETMENT CROSS SECTION
PLAN R4S2
MODEL SCALE 1:25**

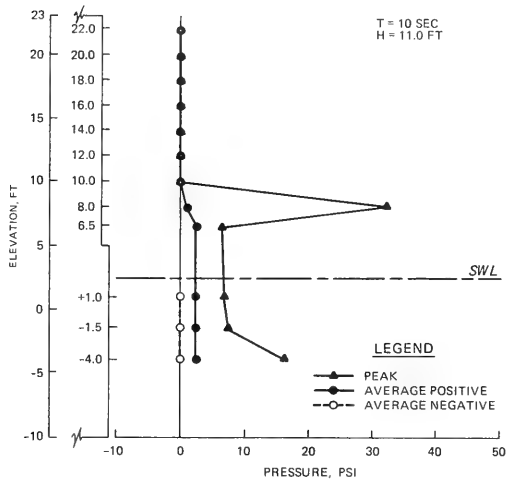
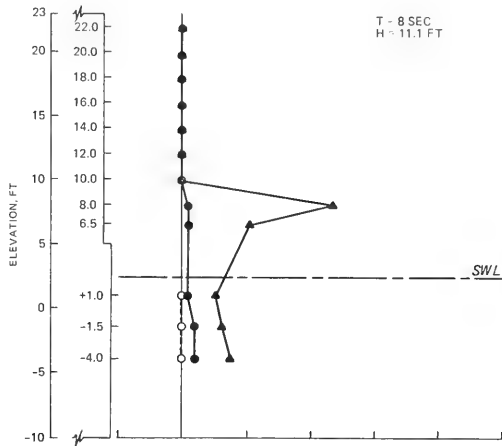

DISTRIBUTION OF WAVE PRESSURES
 PLAN R4S1
 SWL = +2.6 FT
 T = 8 AND 10 SEC
 H = 11.1 AND 11.0 FT

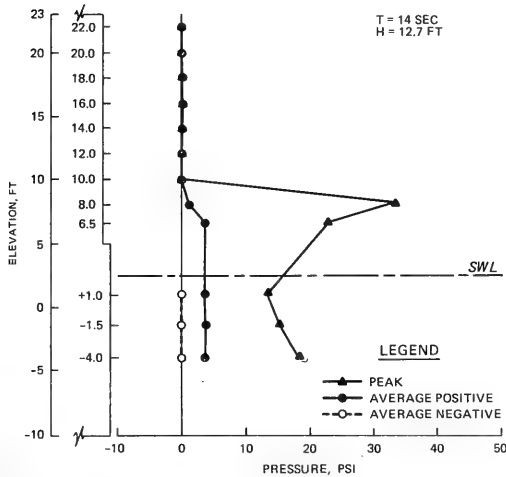
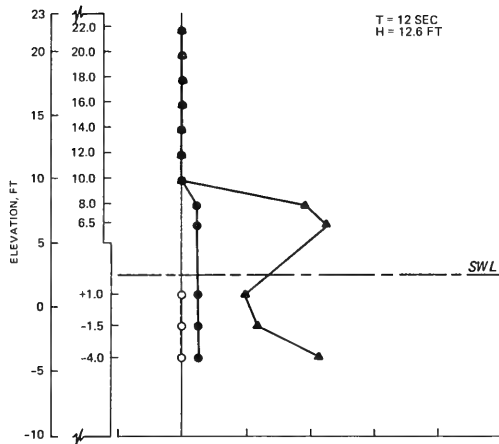

DISTRIBUTION OF WAVE PRESSURES

PLAN R4S1

SWL = +2.6 FT

T = 12 AND 14 SEC

H = 12.6 AND 12.7 FT

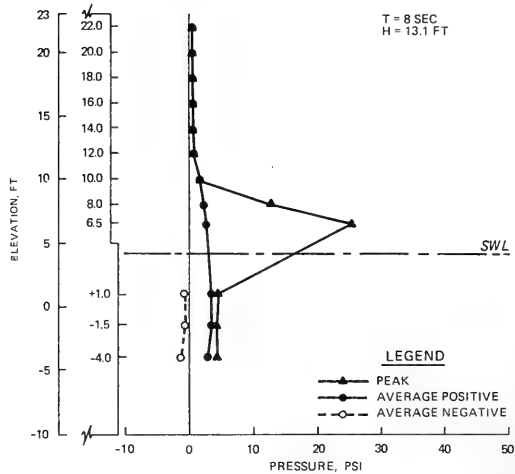
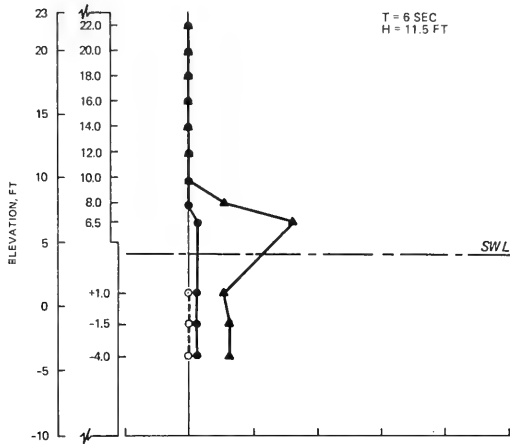

DISTRIBUTION OF WAVE PRESSURES

PLAN R4S1
SWL = +4.3 FT
T = 6 AND 8 SEC
H = 11.5 AND 13.1 FT

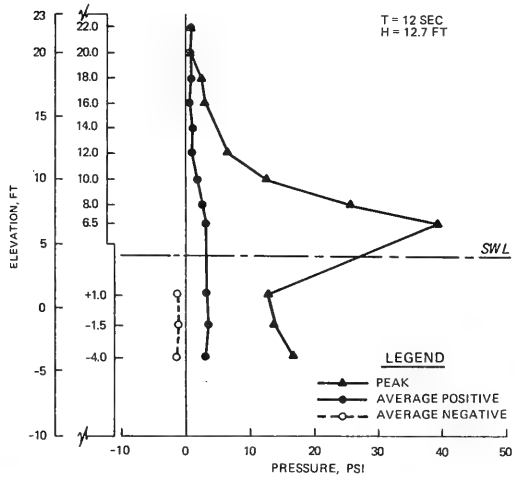
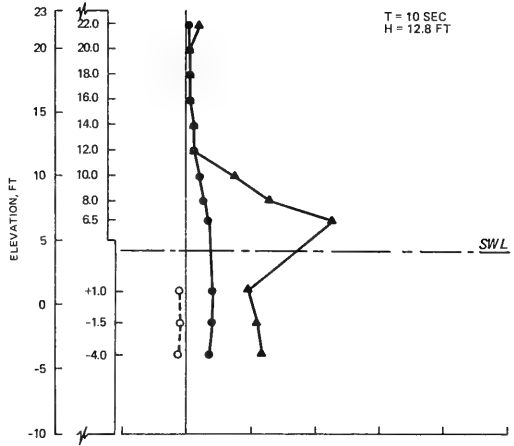

DISTRIBUTION OF WAVE PRESSURES
 PLAN R4S1
 SWL = +4.3 FT
 T = 10 AND 12 SEC
 H = 12.8 AND 12.7 FT

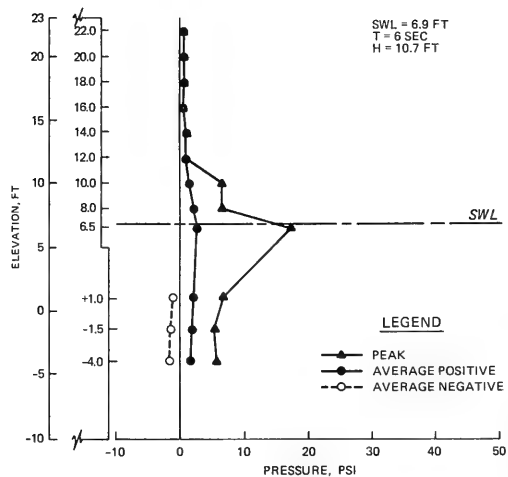
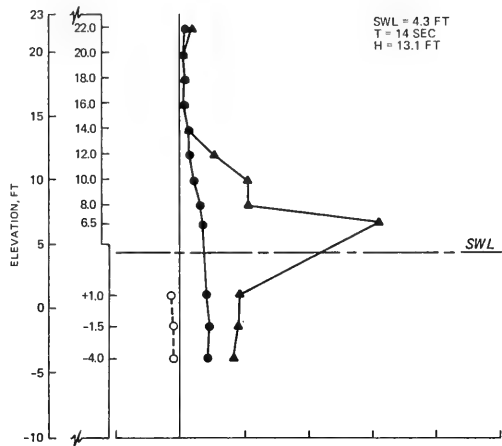

DISTRIBUTION OF WAVE PRESSURES

PLAN R4S1

SWL = +4.3 AND +6.9 FT

T = 14 AND 6 SEC

H = 13.1 AND 10.7 FT

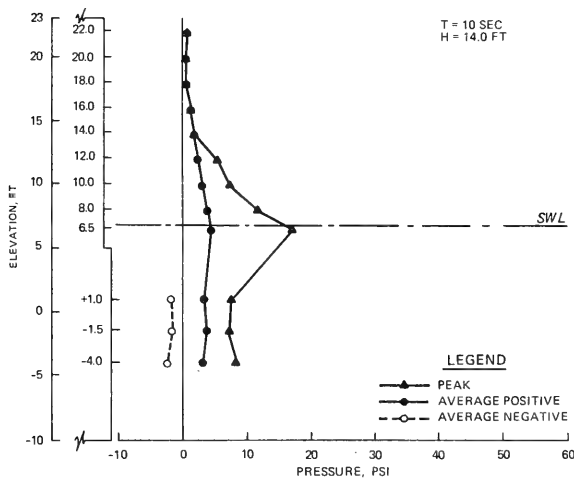
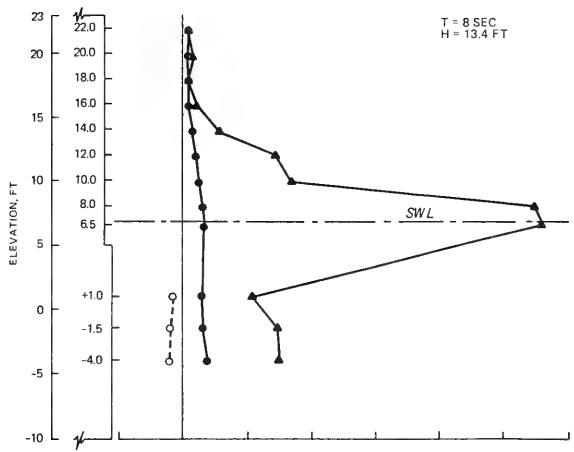

DISTRIBUTION OF WAVE PRESSURES
 PLAN R4S1
 SWL = +6.9 FT
 T = 8 AND 10 SEC
 H = 13.4 AND 14.0 FT

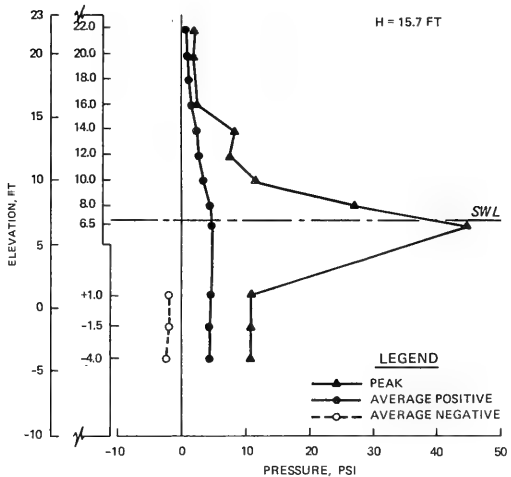
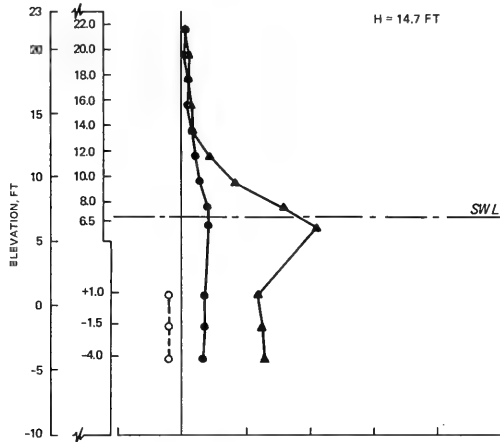

DISTRIBUTION OF WAVE PRESSURES
 PLAN R4S1
 SWL = +6.9 FT, T = 10 SEC
 H = 14.7 AND 15.7 FT

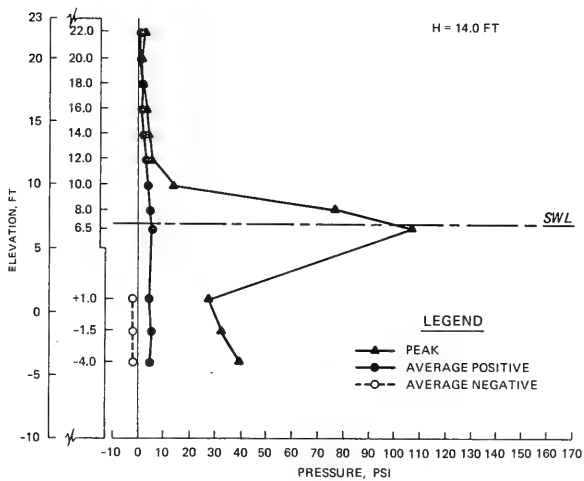
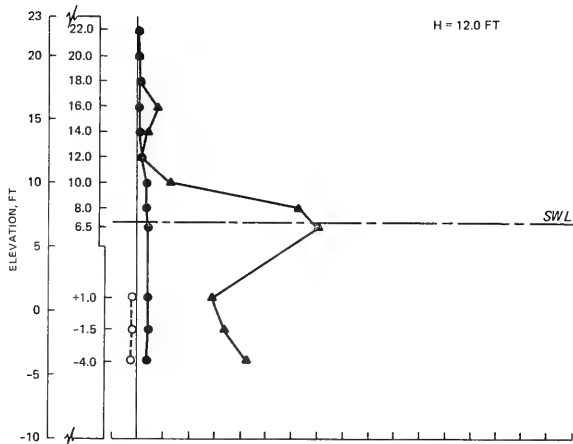

DISTRIBUTION OF WAVE PRESSURES

PLAN R4S1
 SWL = +6.9 FT, T = 12 SEC
 H = 12.0 AND 14.0 FT

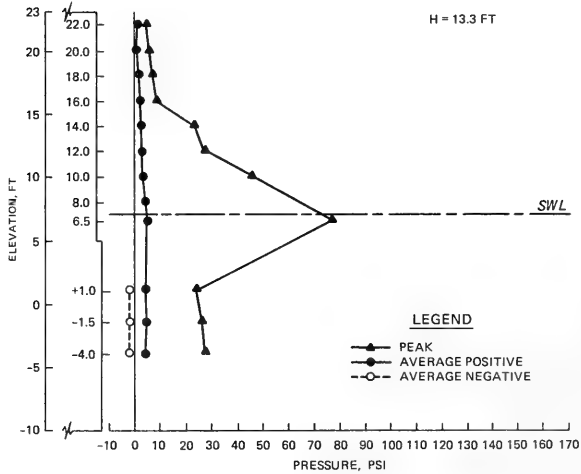
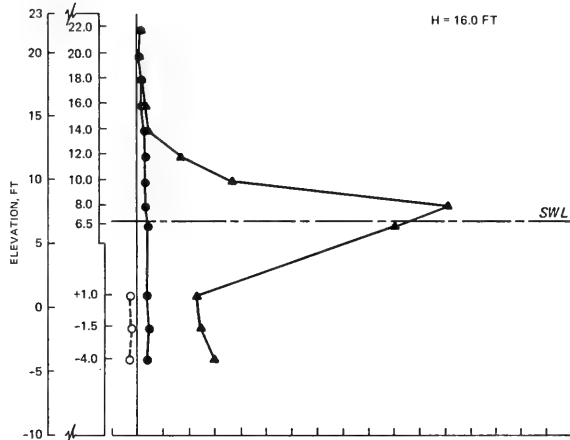

DISTRIBUTION OF WAVE PRESSURES

PLAN R4S1
 SWL = +6.9 FT, T = 12 SEC
 H = 13.3 AND 16.0 FT

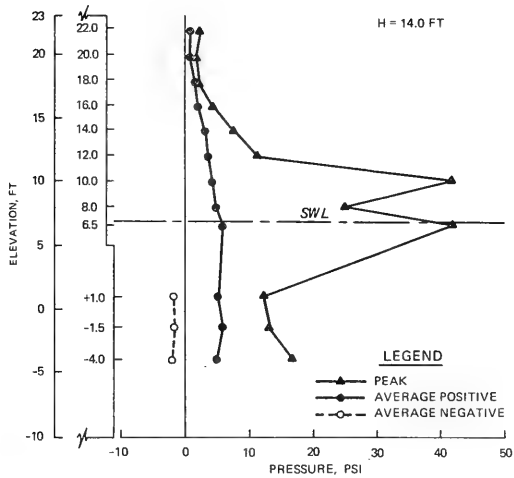
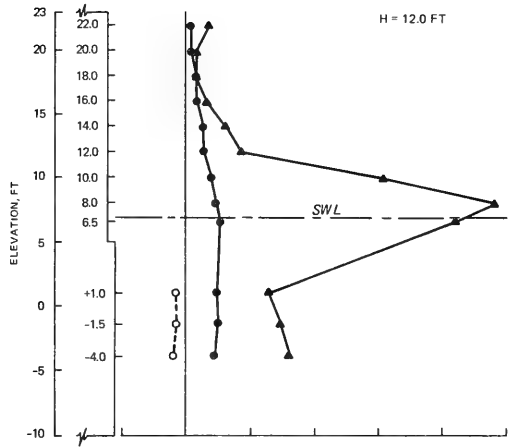

DISTRIBUTION OF WAVE PRESSURES
 PLAN R4S1
 SWL = +6.9 FT, T = 14 SEC
 H = 12.0 AND 14.0 FT

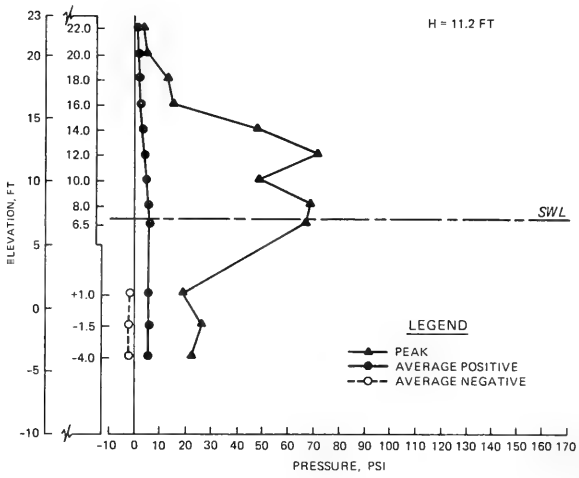
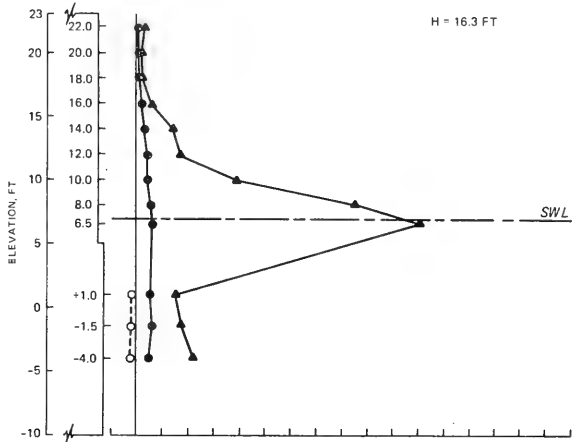

DISTRIBUTION OF WAVE PRESSURES
 PLAN R4S1
 SWL = +6.9 FT, T = 14 SEC
 H = 16.3 AND 11.2 FT

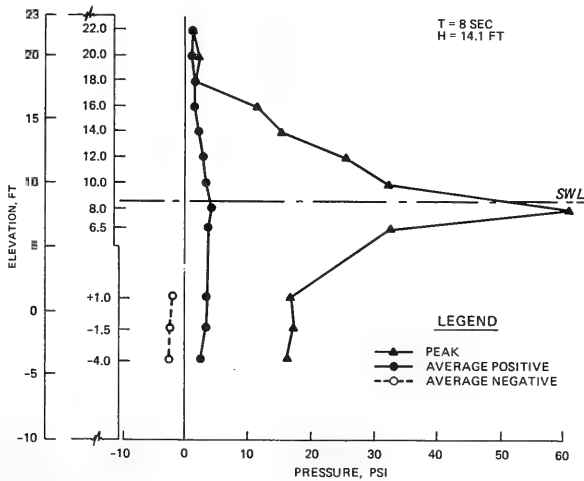
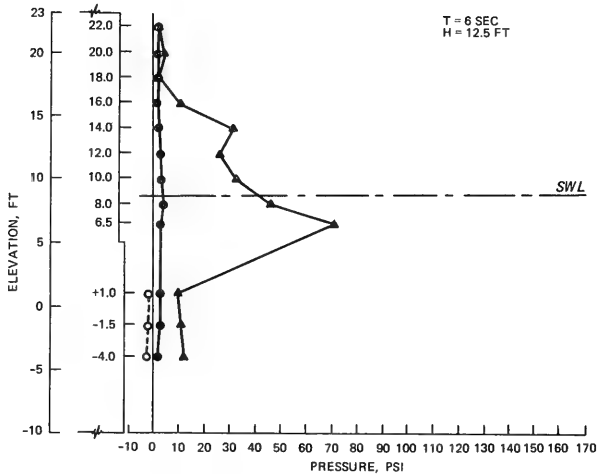

DISTRIBUTION OF WAVE PRESSURES
 PLAN R4S1
 SWL = +8.6 FT
 T = 6 AND 8 SEC
 H = 12.5 AND 14.1 FT

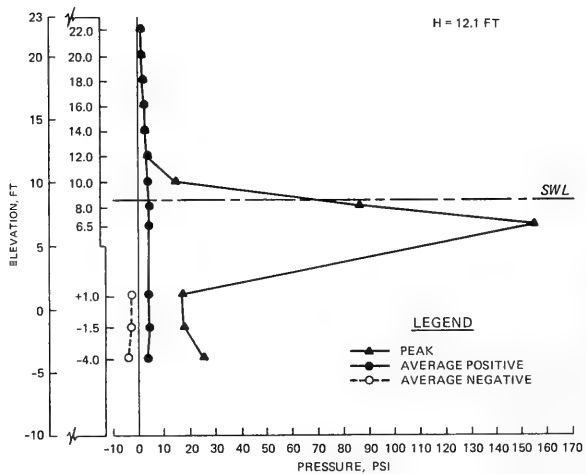
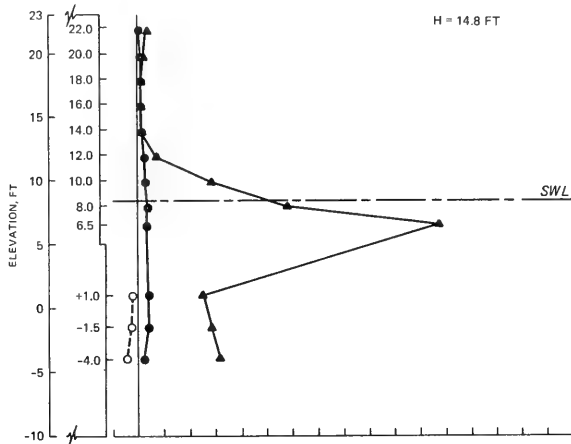

DISTRIBUTION OF WAVE PRESSURES

PLAN R4S1
 SWL = +8.6 FT, T = 10 SEC
 H = 12.1 AND 14.8 FT

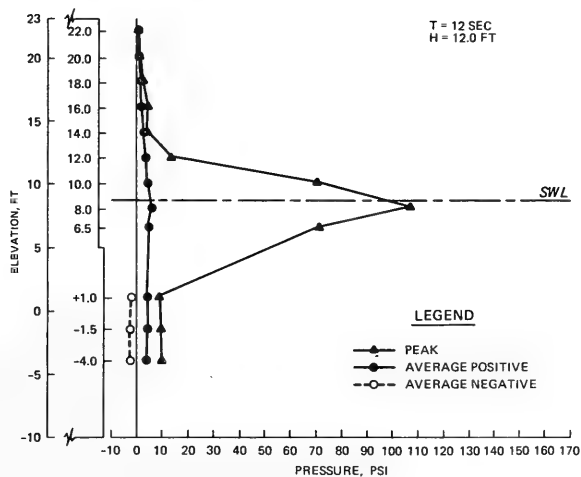
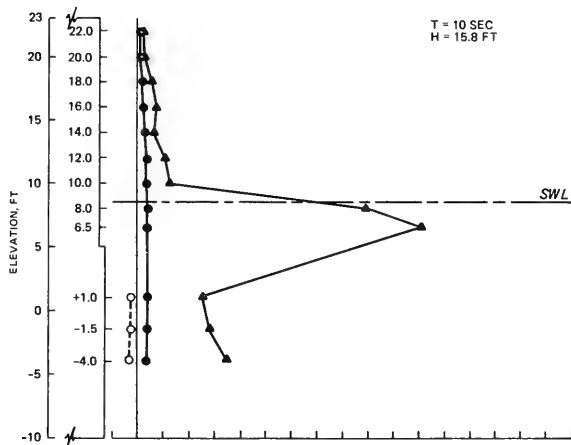

DISTRIBUTION OF WAVE PRESSURES

PLAN R4S1
SWL = +8.6 FT
T = 10 AND 12 SEC
H = 15.8 AND 12.0 FT

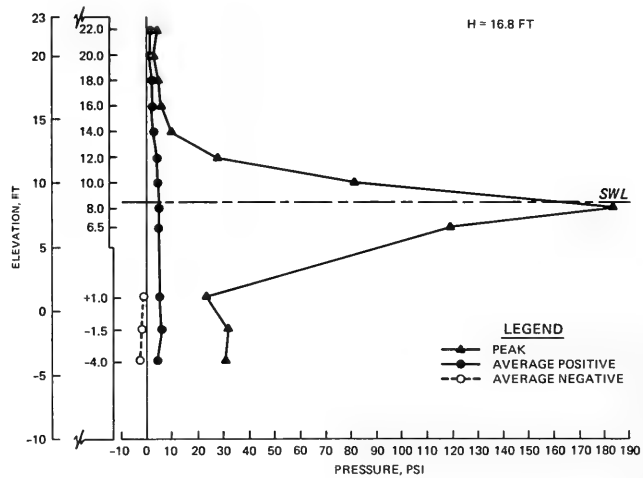
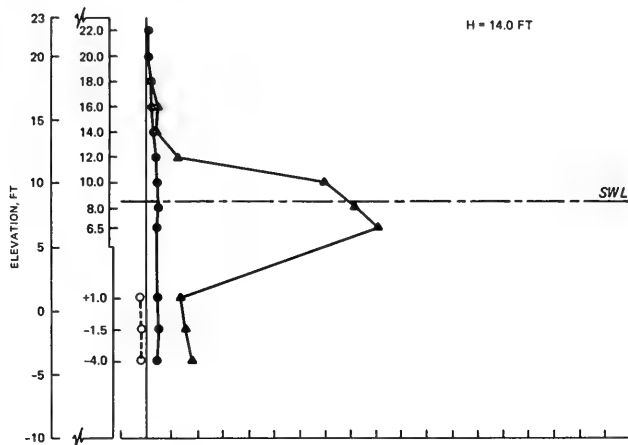

DISTRIBUTION OF WAVE PRESSURES

PLAN R4S1
 SWL = +8.6 FT, T = 12 SEC
 H = 14.0 AND 16.8 FT

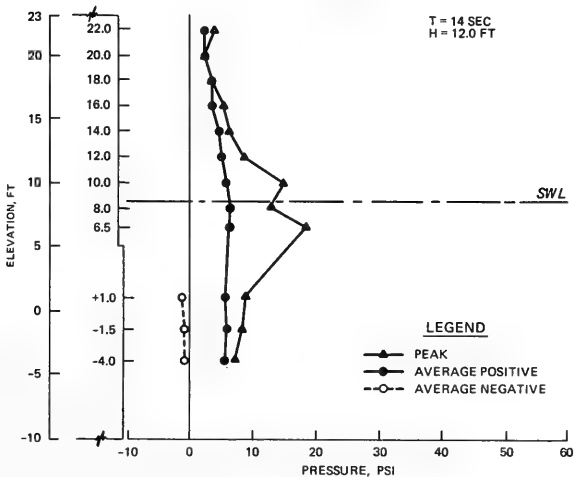
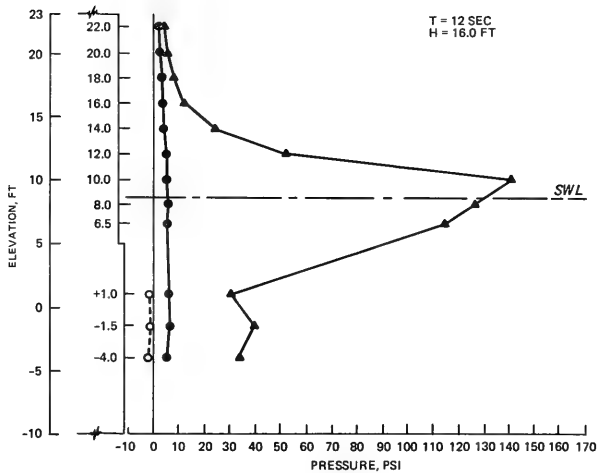

DISTRIBUTION OF WAVE PRESSURES
 PLAN R4S1
 SWL = +8.6 FT
 T = 12 AND 14 SEC
 H = 16.0 AND 12.0 FT

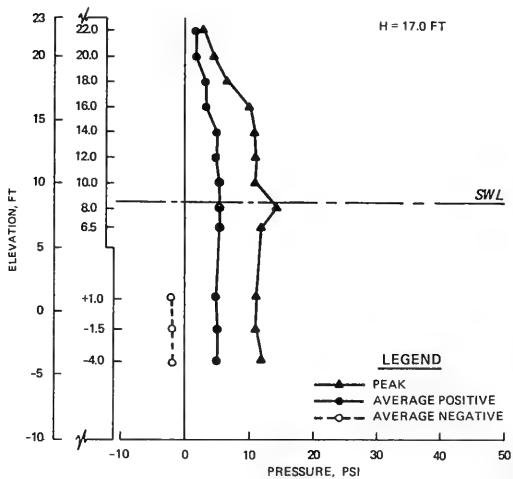
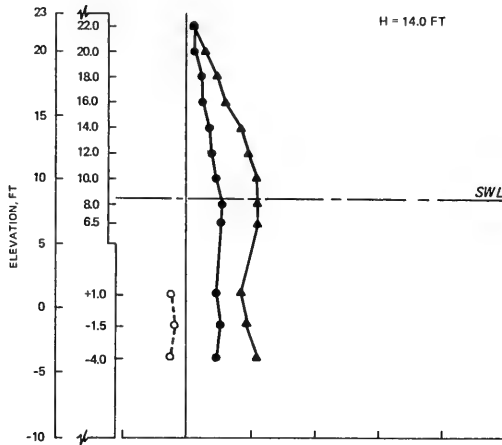

DISTRIBUTION OF WAVE PRESSURES

PLAN R4S1
 SWL = +8.6 FT, T = 14 SEC
 H = 14.0 AND 17.0 FT

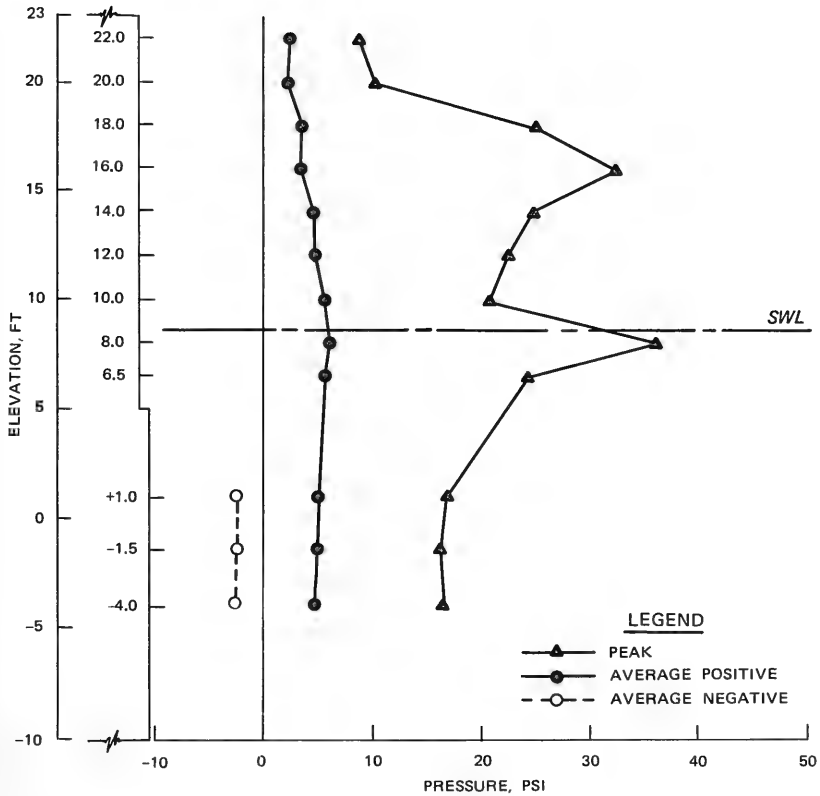

DISTRIBUTION OF WAVE PRESSURES
 PLAN R4S1
 SWL = +8.6 FT
 T = 14 SEC
 H = 11.4 FT

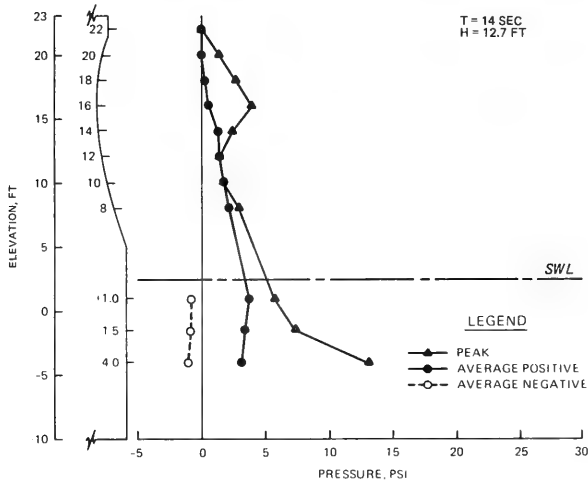
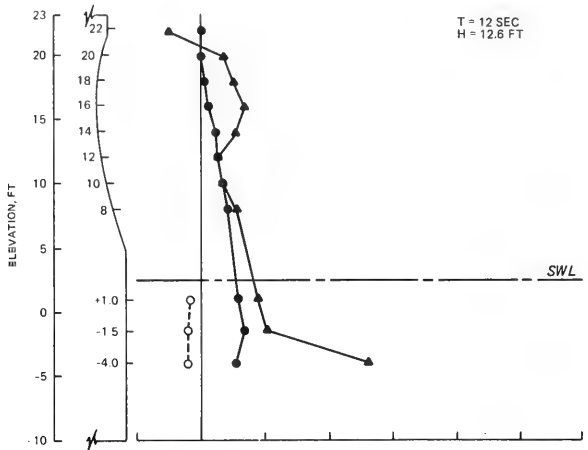

DISTRIBUTION OF WAVE PRESSURES
 PLAN R4S2
 SWL = + 2.6 FT
 T = 12 AND 14 SEC
 H = 12.6 AND 12.7 FT

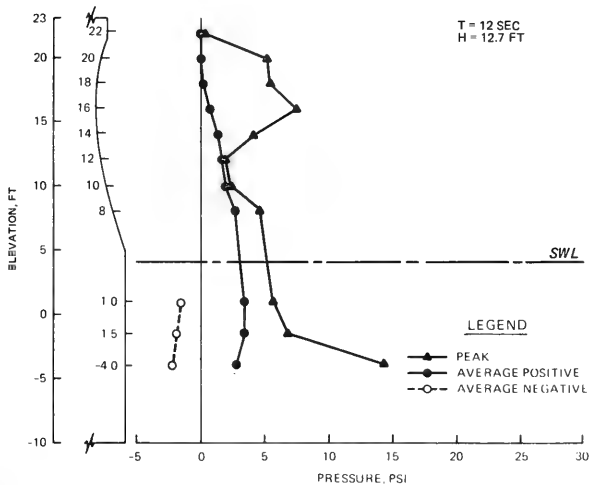
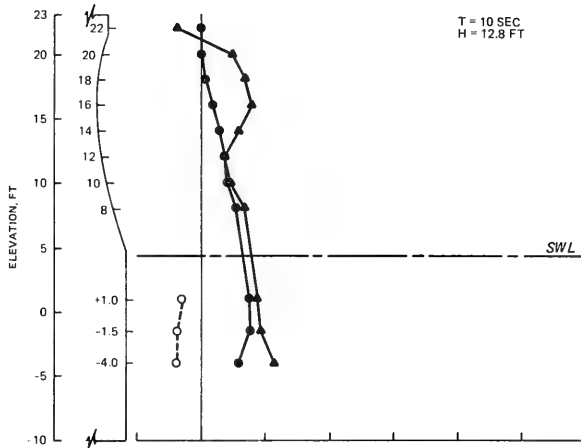

DISTRIBUTION OF WAVE PRESSURES

PLAN R4S2
SWL = +4.3 FT
T = 10 AND 12 SEC
H = 12.8 AND 12.7 FT

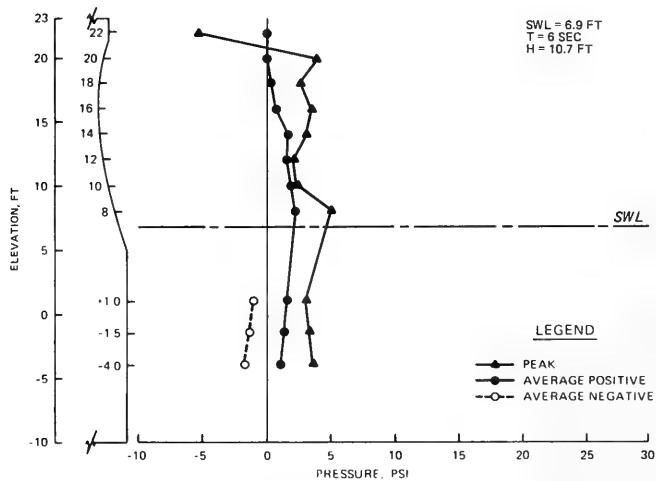
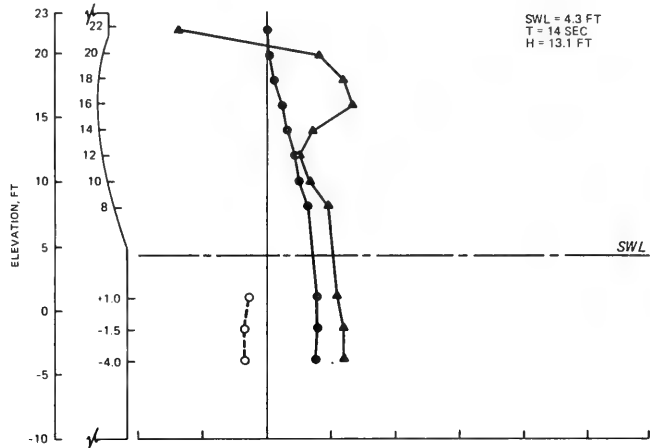

LEGEND

- ▲ PEAK
- AVERAGE POSITIVE
- AVERAGE NEGATIVE

DISTRIBUTION OF WAVE PRESSURES

PLAN R4S2
SWL = +4.3 AND +6.9 FT
T = 14 AND 6 SEC
H = 13.1 AND 10.7 FT

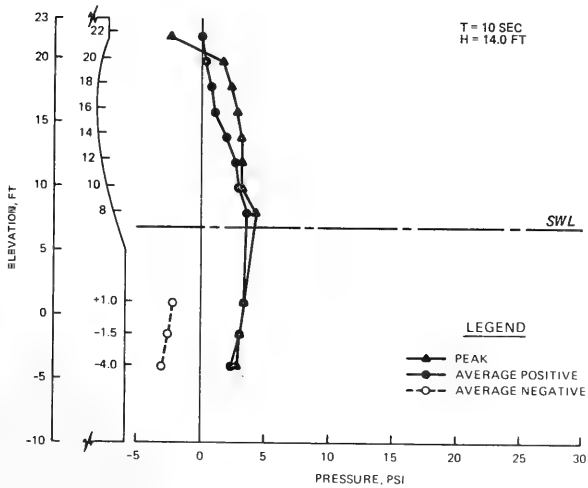
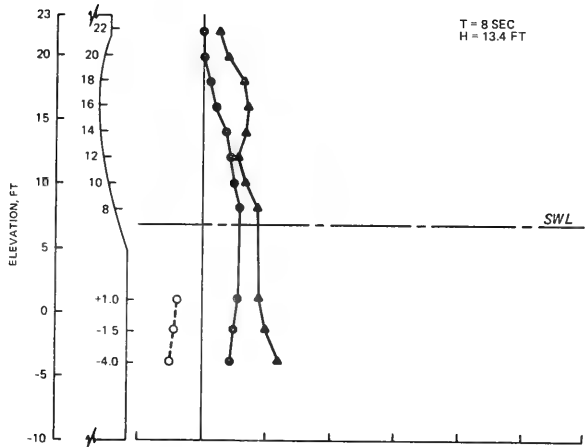

DISTRIBUTION OF WAVE PRESSURES
 PLAN R4S2
 SWL = +6.9 FT
 T = 8 AND 10 SEC
 H = 13.4 AND 14.0 FT

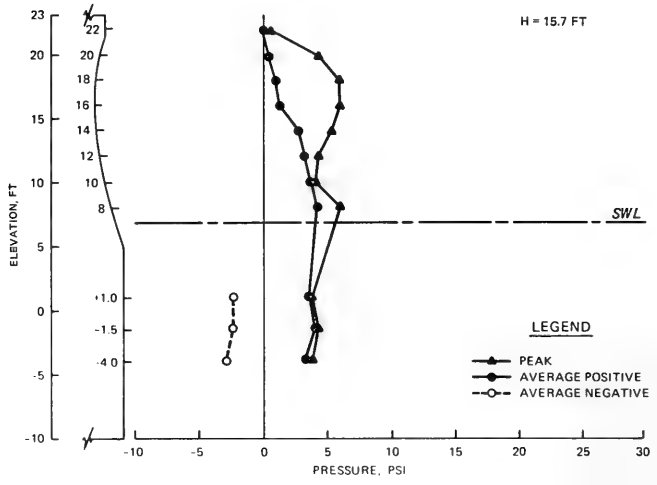
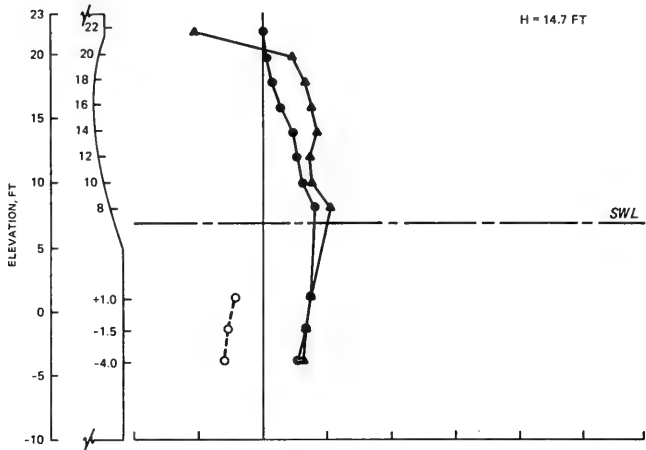

DISTRIBUTION OF WAVE PRESSURES
 PLAN R4S2
 SWL = +6.9 FT, T = 10 SEC
 H = 14.7 AND 15.7 FT

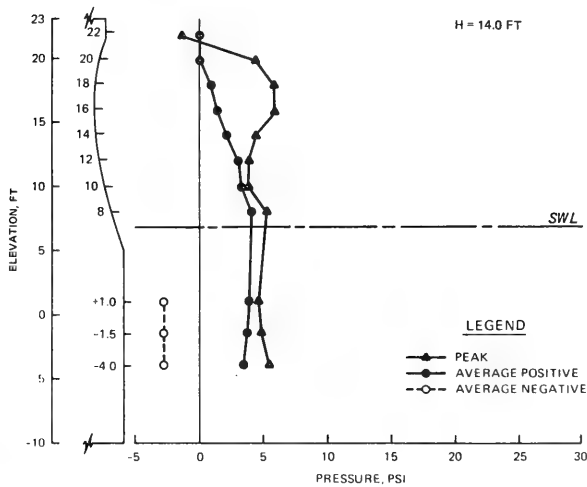
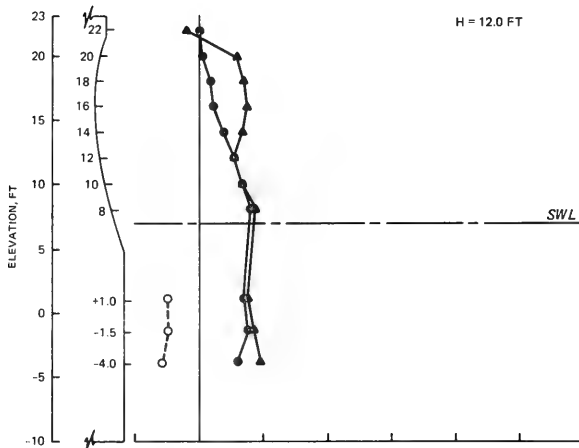

DISTRIBUTION OF WAVE PRESSURES
PLAN R4S2

SWL = +6.9 FT, T = 12 SEC
H = 12.0 AND 14.0 FT

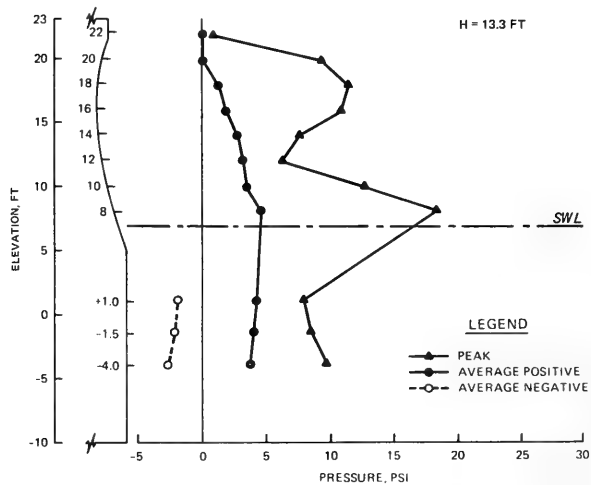
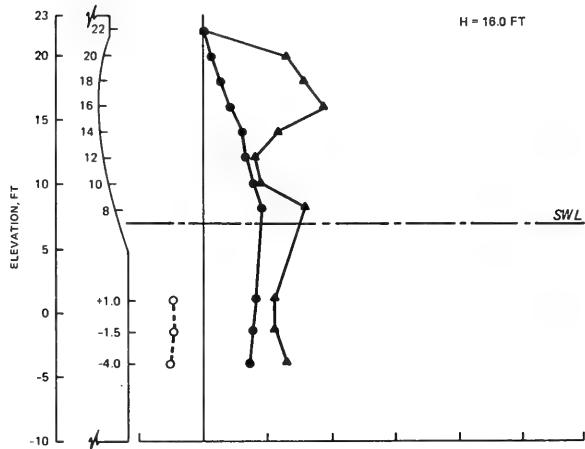

DISTRIBUTION OF WAVE PRESSURES
 PLAN R4S2
 SWL = +6.9 FT, T = 12 SEC
 H = 16.0 AND 13.3 FT

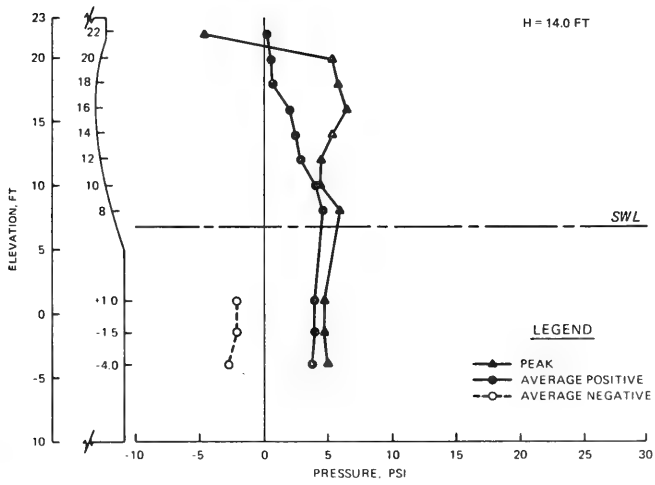
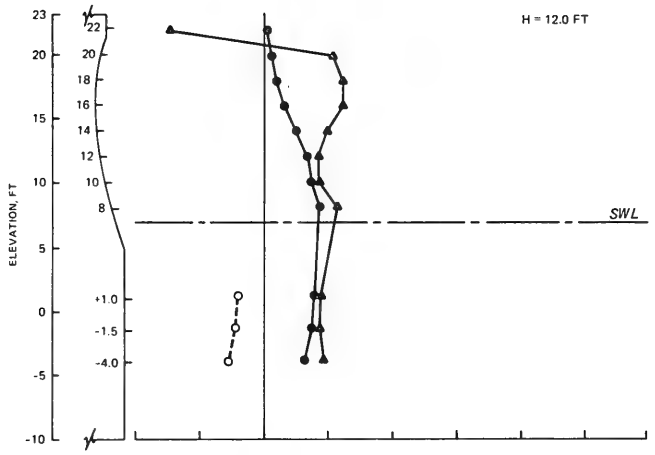

LEGEND

- ▲ PEAK
- AVERAGE POSITIVE
- AVERAGE NEGATIVE

DISTRIBUTION OF WAVE PRESSURES
 PLAN R4S2
 SWL = +6.9 FT, T = 14 SEC
 H = 12.0 AND 14.0 FT

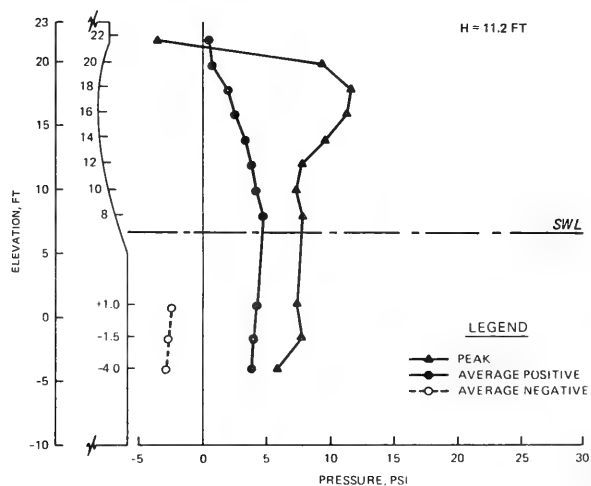
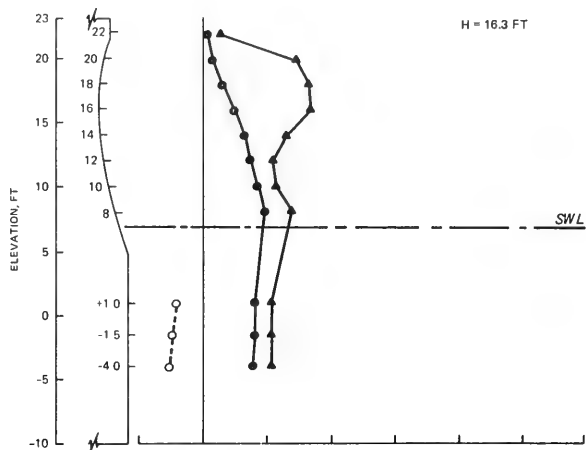

DISTRIBUTION OF WAVE PRESSURES
 PLAN R4S2
 SWL = +6.9 FT, T = 14 SEC
 H = 16.3 AND 11.2 FT

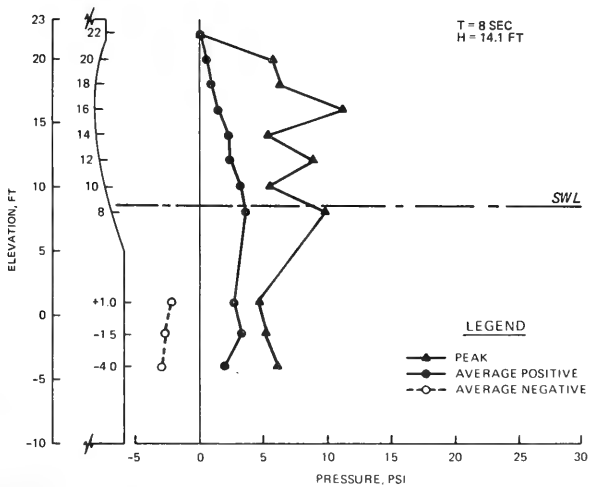
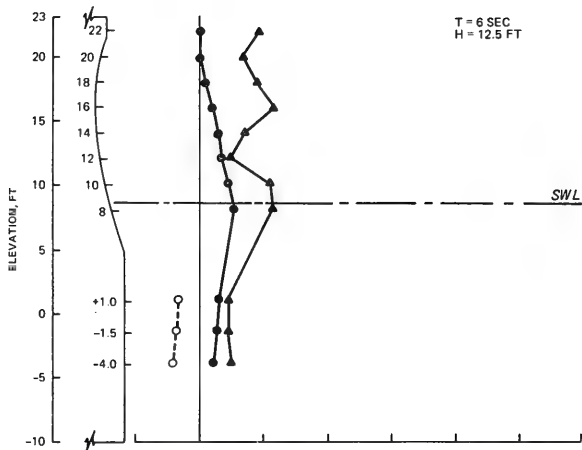

DISTRIBUTION OF WAVE PRESSURES

PLAN R4S2

SWL = +8.6 FT

T = 6 AND 8 SEC

H = 12.5 AND 14.1 FT

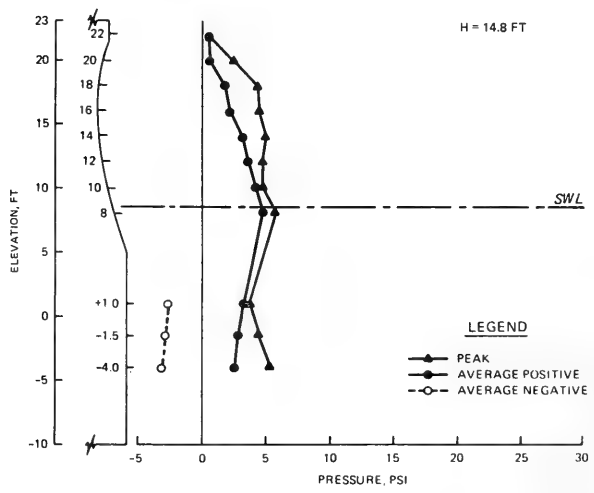
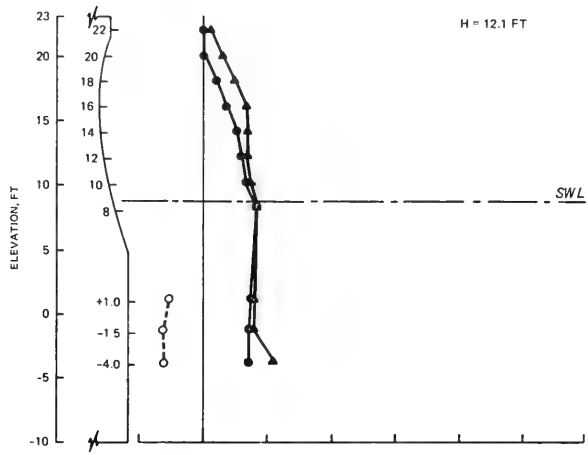

DISTRIBUTION OF WAVE PRESSURES
 PLAN R4S2
 SWL = +8.6 FT, T = 10 SEC
 H = 12.1 AND 14.8 FT

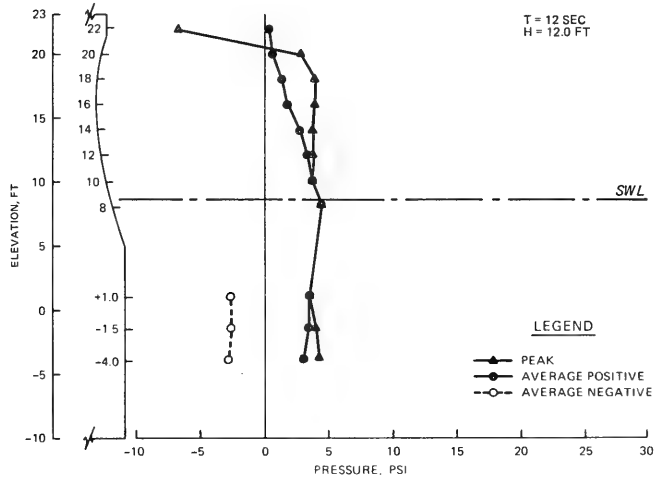
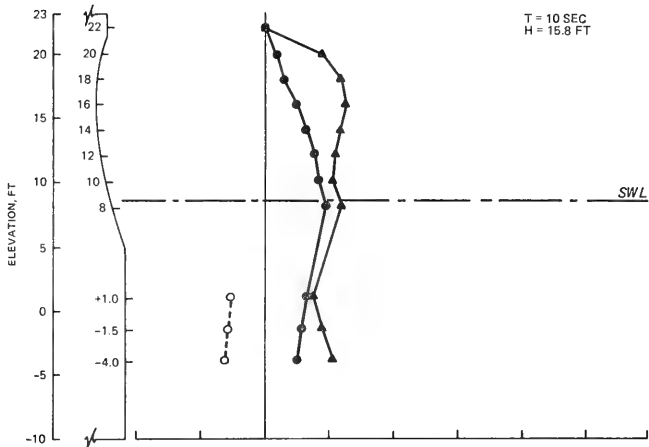

DISTRIBUTION OF WAVE PRESSURES

PLAN R4S2

SWL = + 8.6 FT

T = 10 AND 12 SEC

H = 15.8 AND 12.0 FT

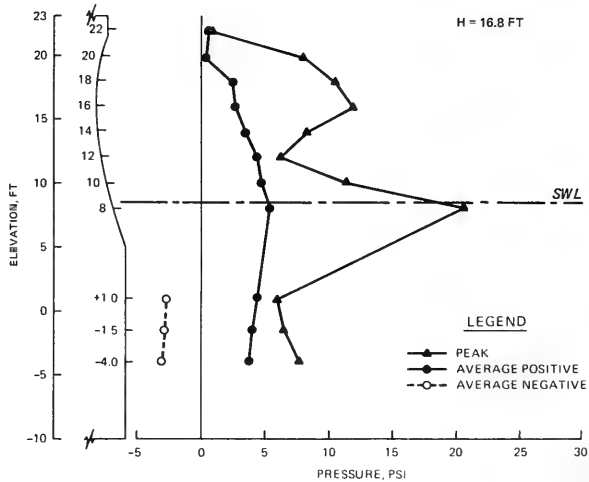
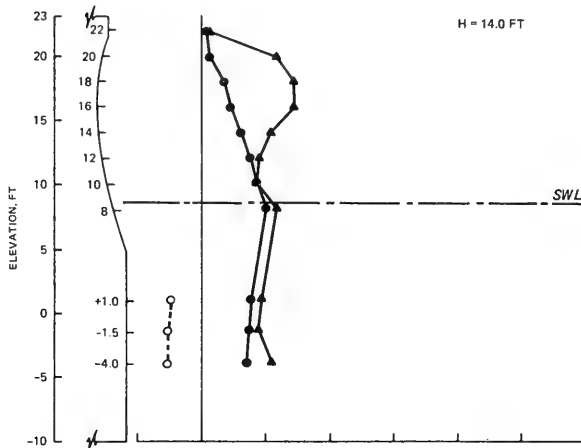

DISTRIBUTION OF WAVE PRESSURES

PLAN R4S2

SWL = +8.6 FT, T = 12 SEC

H = 14.0 AND 16.8 FT

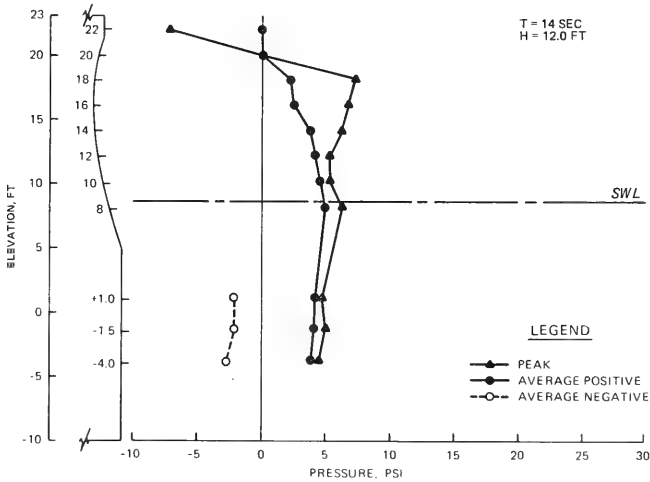
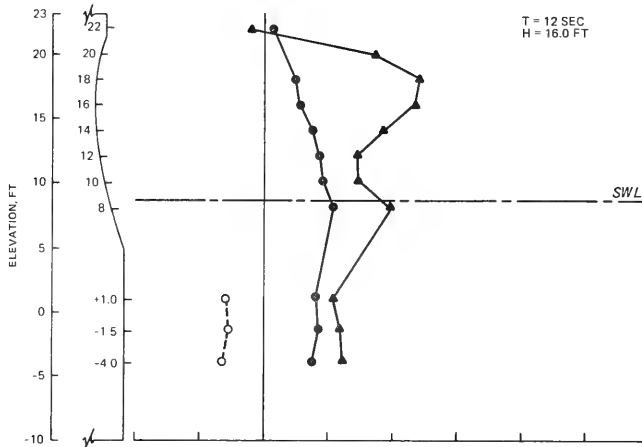

DISTRIBUTION OF WAVE PRESSURES

PLAN R4S2

SWL = +8.6 FT

T = 12 AND 14 SEC

H = 16.0 AND 12.0 FT

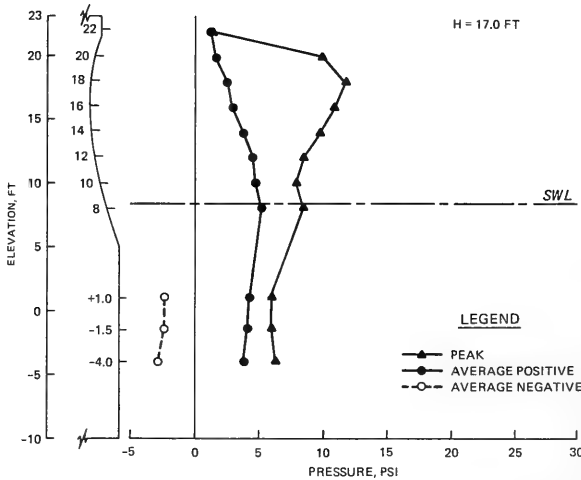
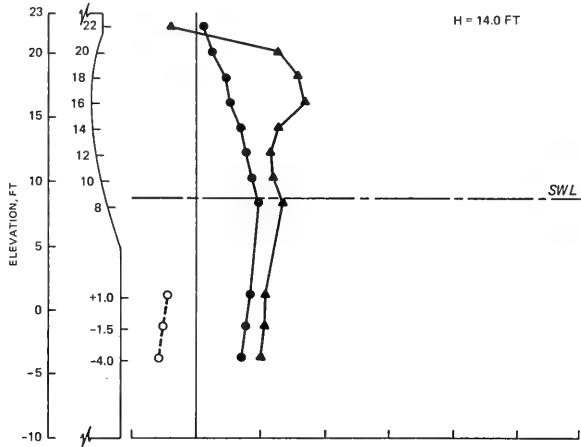

LEGEND

- ▲ PEAK
- AVERAGE POSITIVE
- AVERAGE NEGATIVE

DISTRIBUTION OF WAVE PRESSURES

PLAN R4S2
 SWL = +8.6 FT, T = 14 SEC
 H = 14.0 AND 17.0 FT

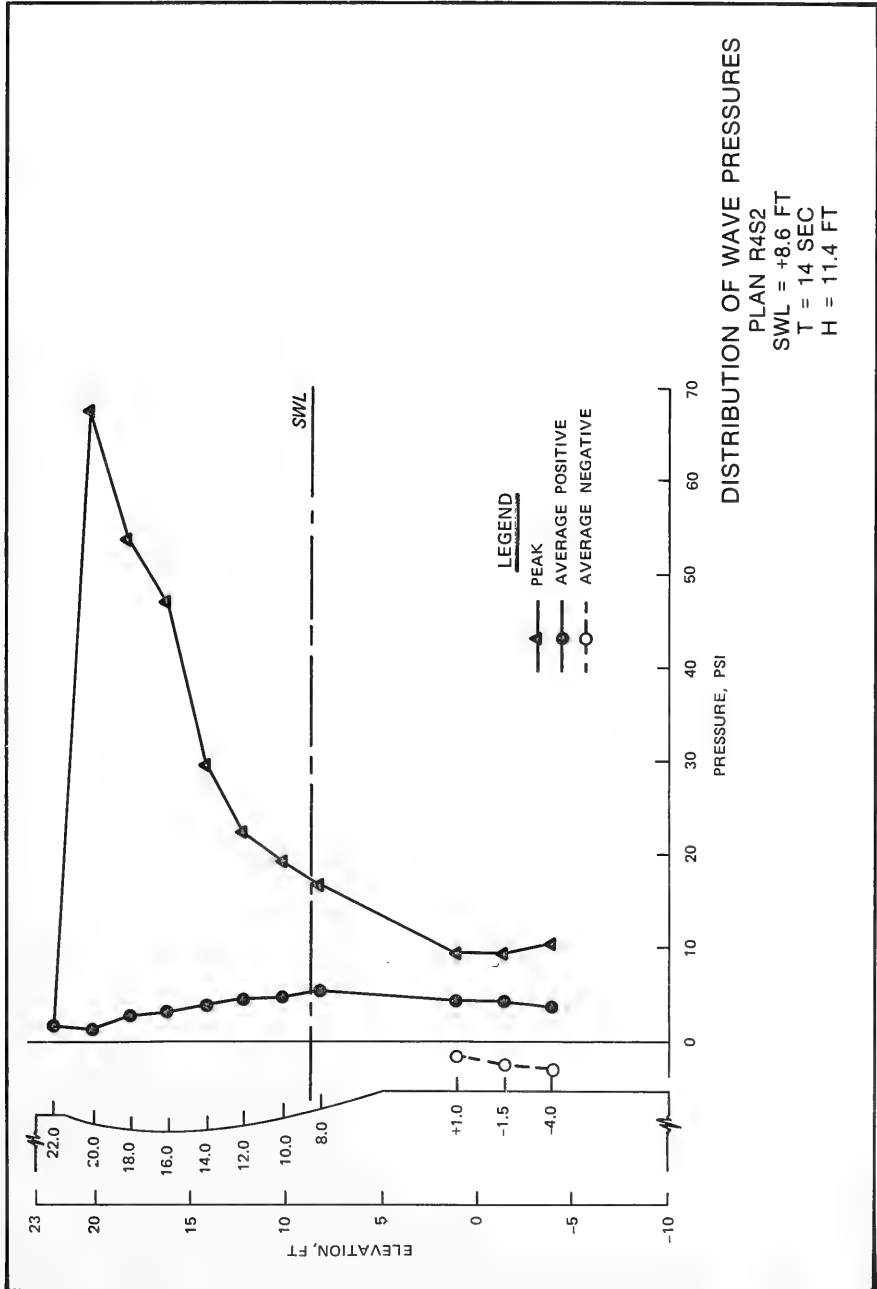

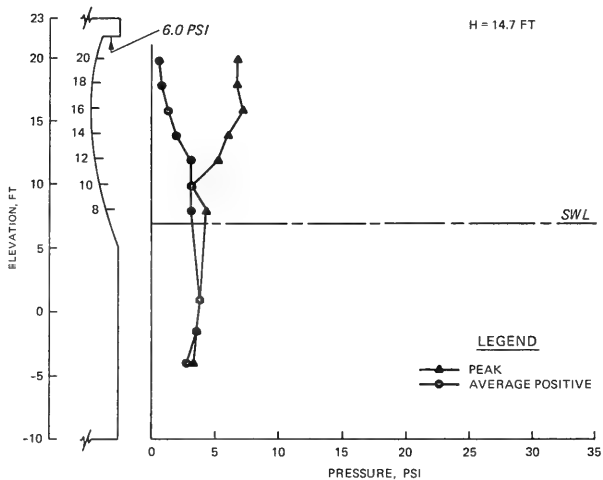
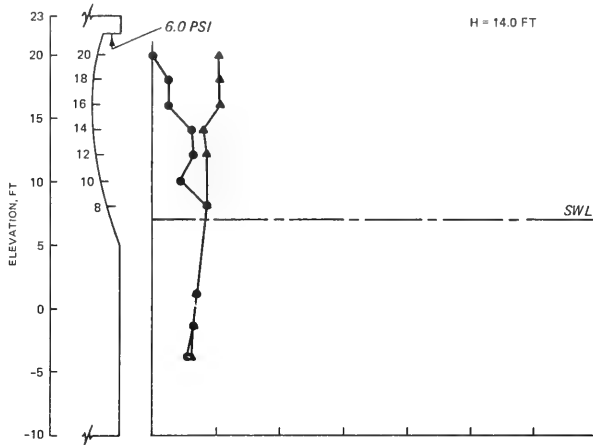

DISTRIBUTION OF WAVE PRESSURES

PLAN R4S3

SWL = +6.9 FT, T = 10 SEC

H = 14.0 AND 14.7 FT

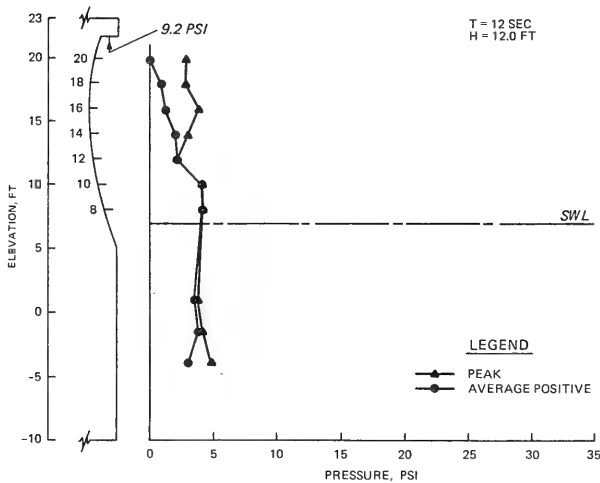
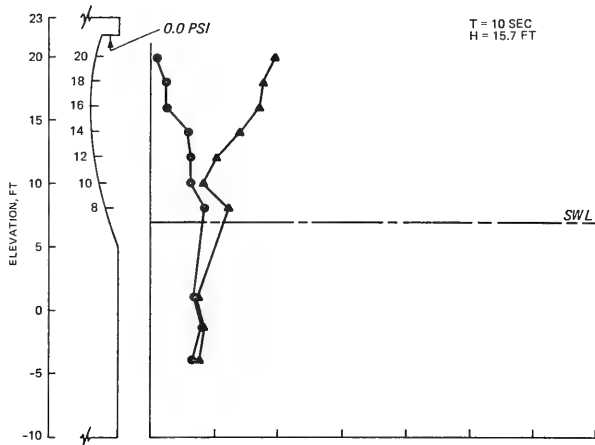

DISTRIBUTION OF WAVE PRESSURES

PLAN R4S3
SWL = +6.9 FT
T = 10 AND 12 SEC
H = 15.7 AND 12.0 FT

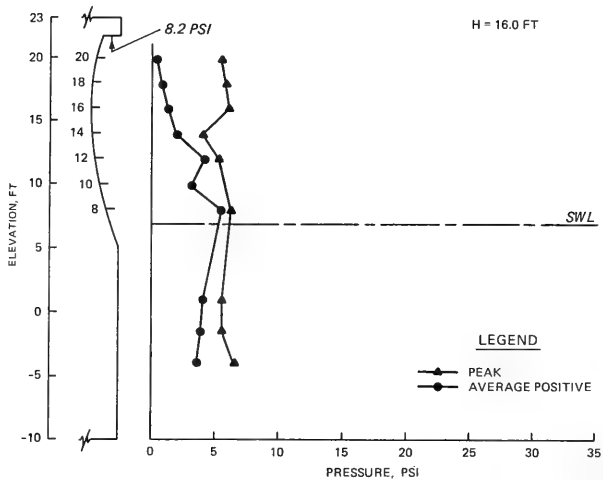
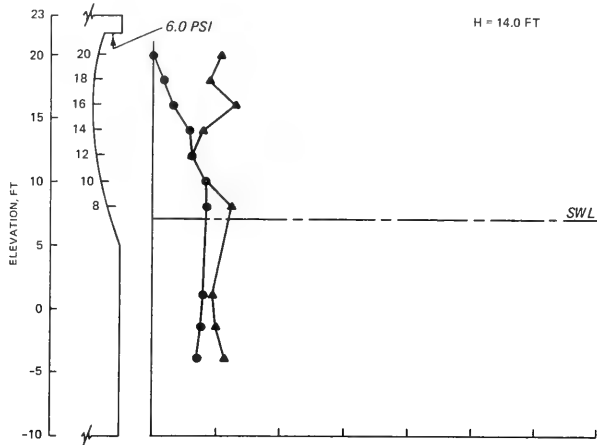

DISTRIBUTION OF WAVE PRESSURES

PLAN R4S3

SWL = +6.9 FT, T = 12 SEC

H = 14.0 AND 16.0 FT

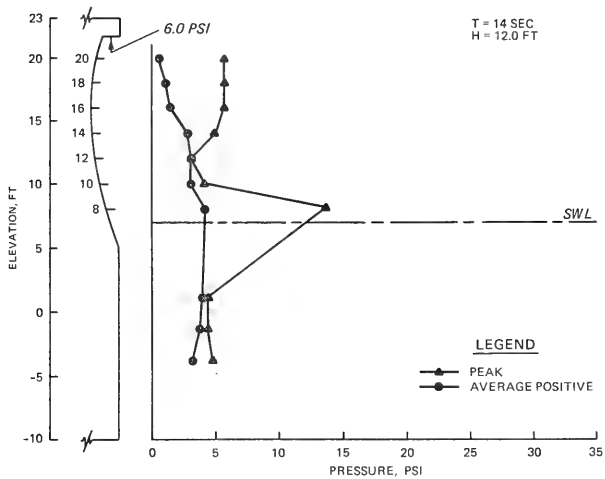
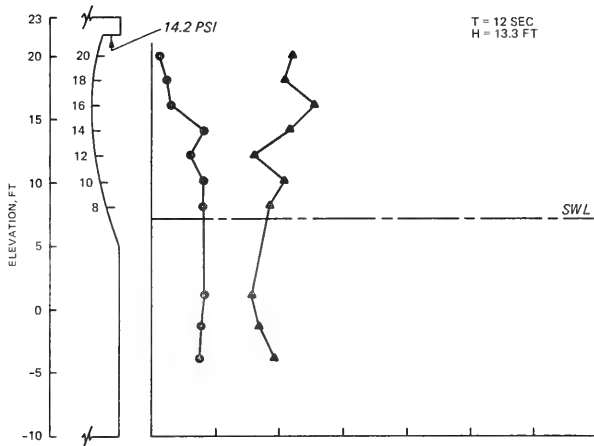

DISTRIBUTION OF WAVE PRESSURES

PLAN R4S3
SWL = +6.9 FT
T = 12 AND 14 SEC
H = 13.3 AND 12.0 FT

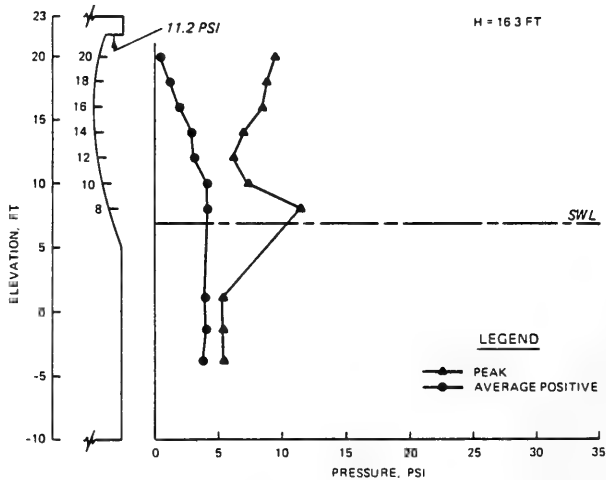
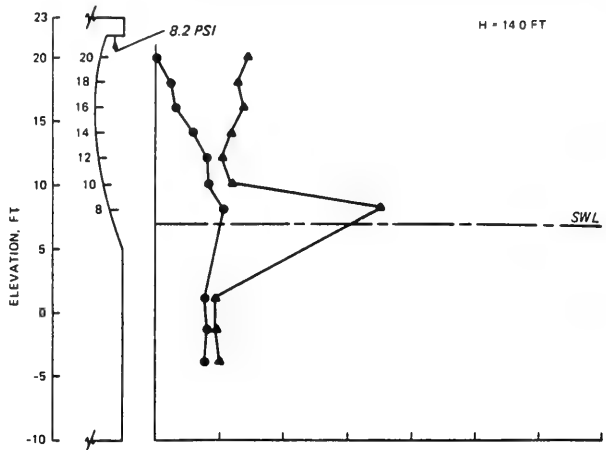

LEGEND
 ● PEAK
 ○ AVERAGE POSITIVE

DISTRIBUTION OF WAVE PRESSURES
 PLAN R4S3
 SWL = +6.9 FT, T = 14 SEC
 H = 14.0 AND 16.3 FT

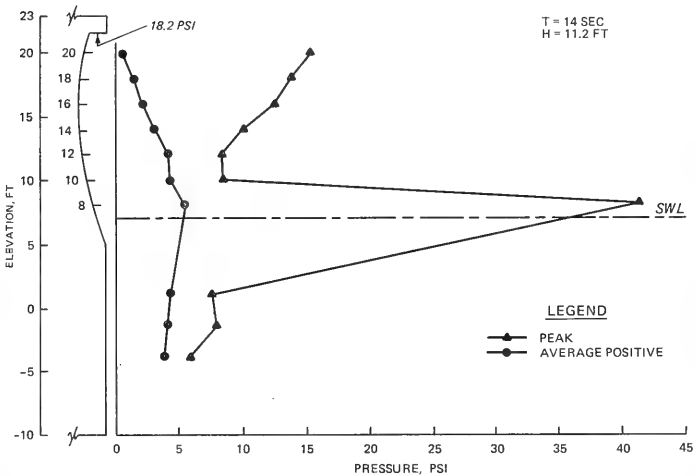
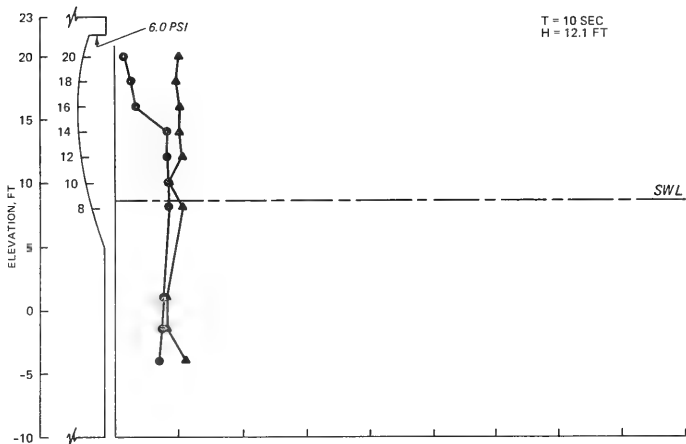

DISTRIBUTION OF WAVE PRESSURES

PLAN R4S3

SWL = +8.6 AND +6.9 FT

T = 10 AND 14 SEC

H = 12.1 AND 11.2 FT

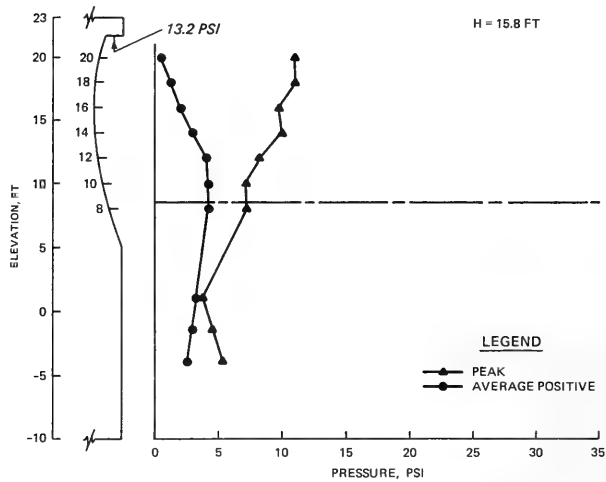
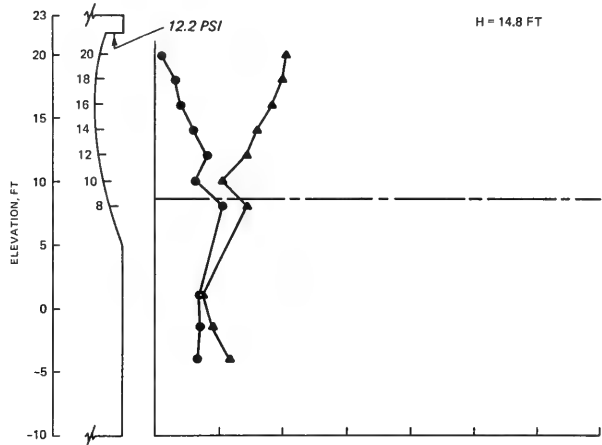

DISTRIBUTION OF WAVE PRESSURES

PLAN R4S3
 SWL = +8.6 FT, T = 10 SEC
 H = 14.8 AND 15.8 FT

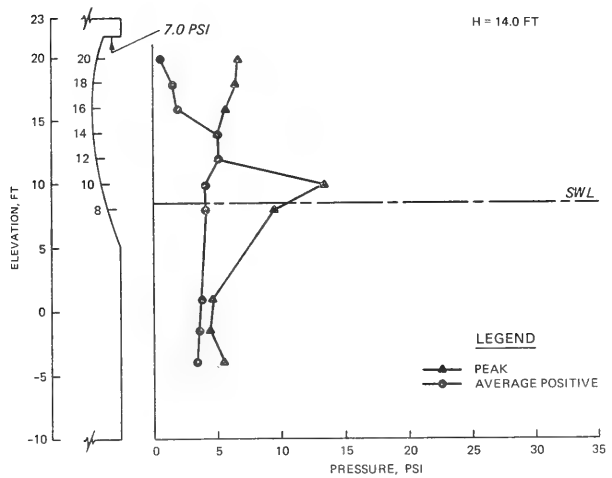
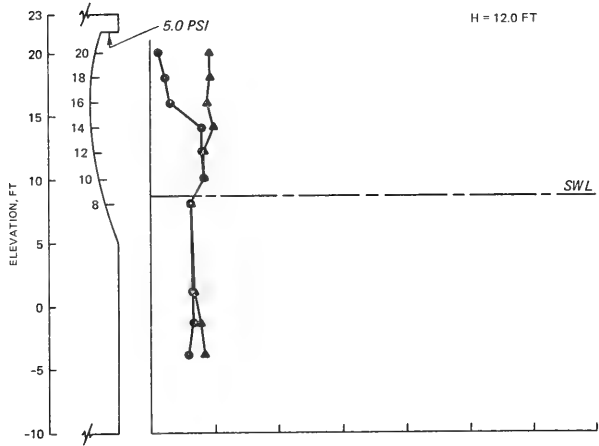

DISTRIBUTION OF WAVE PRESSURES
 PLAN R4S3
 SWL = +8.6 FT, T = 12 SEC
 H = 12.0 AND 14.0 FT

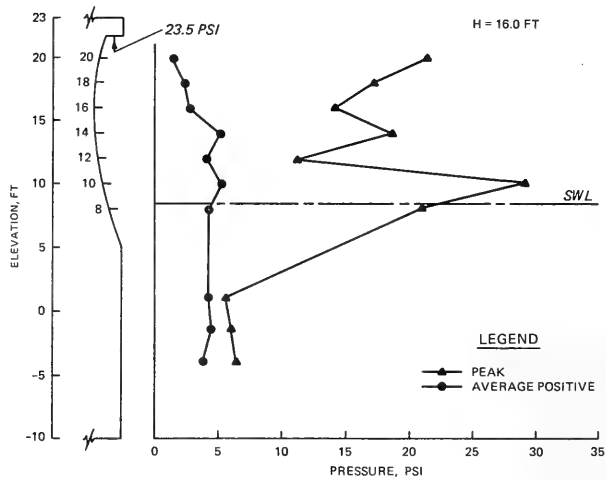
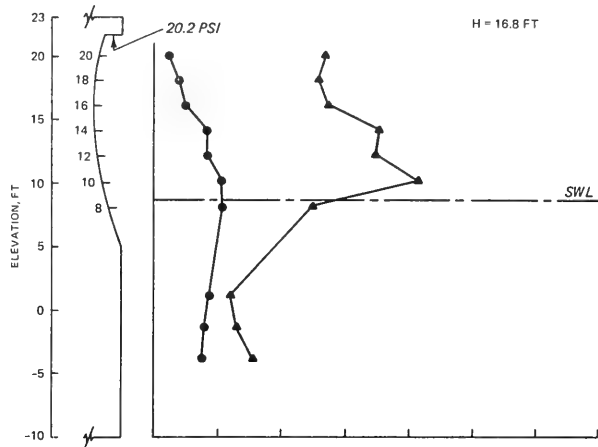

DISTRIBUTION OF WAVE PRESSURES

PLAN R4S3

SWL = +8.6 FT, T = 12 SEC

H = 16.8 AND 16.0 FT

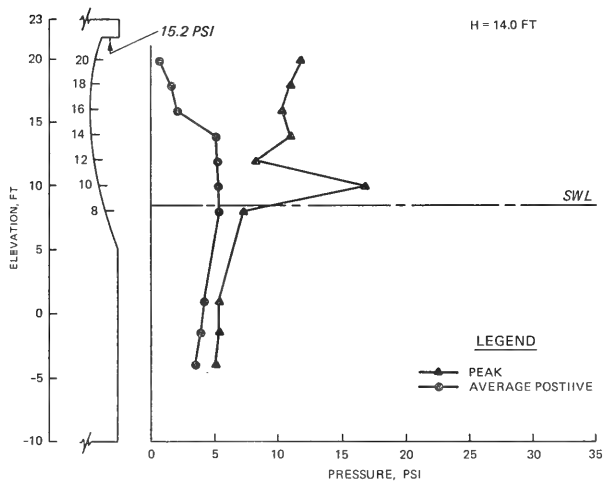
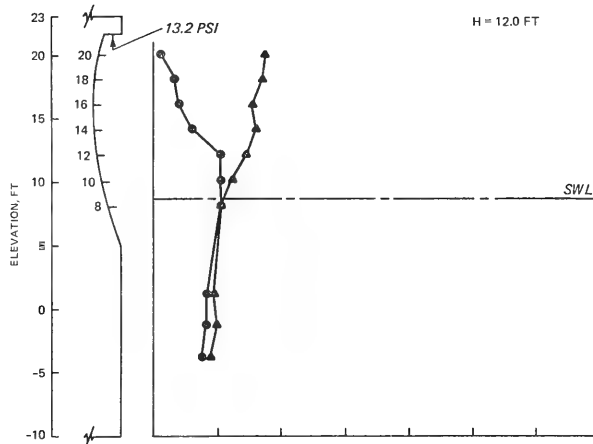

DISTRIBUTION OF WAVE PRESSURES

PLAN R4S3
 SWL = +8.6 FT, T = 14 SEC
 H = 12.0 AND 14.0 FT

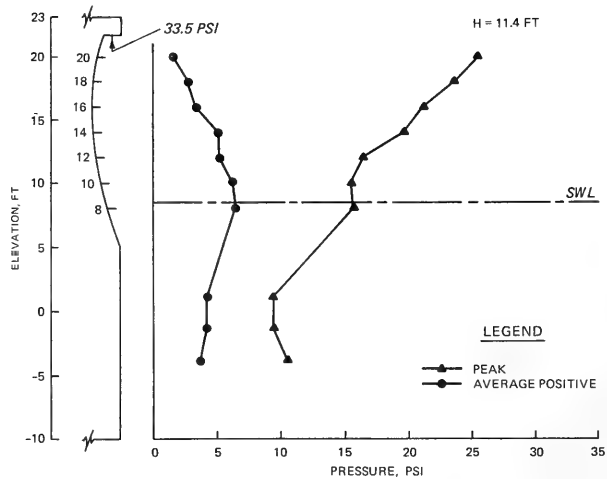
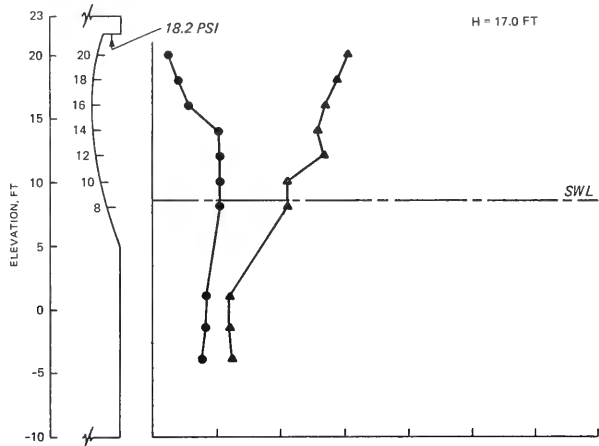

DISTRIBUTION OF WAVE PRESSURES

PLAN R4S3
 SWL = +8.6 FT, T = 14 SEC
 H = 17.0 AND 11.4 FT

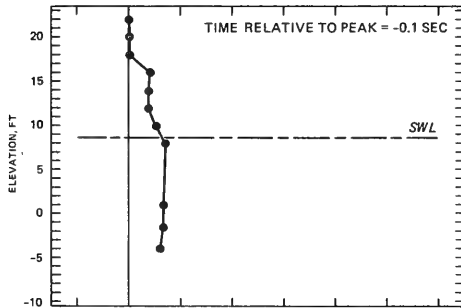
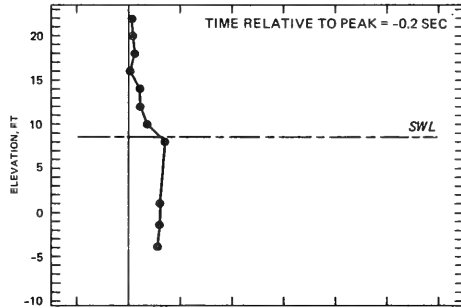
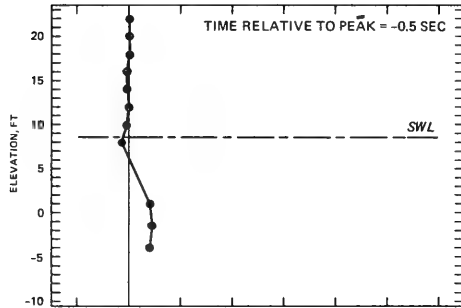

INSTANTANEOUS WAVE PRESSURE DISTRIBUTION

PLAN R4S2

SWL = +8.6 FT, T = 12 SEC, H = 12.0 FT

TIME INCREMENT = -0.5 TO -0.1 SEC

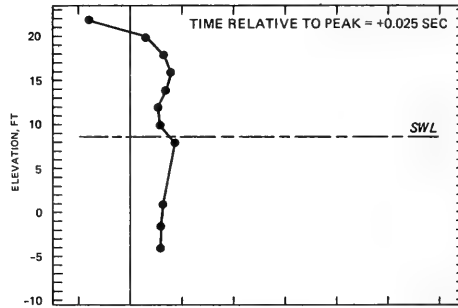
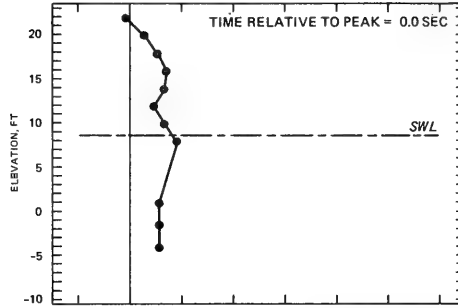
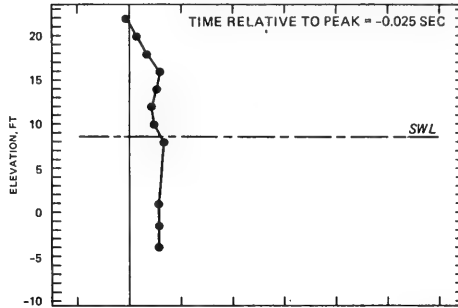

INSTANTANEOUS WAVE PRESSURE DISTRIBUTION

PLAN R4S2

SWL = +8.6 FT, T = 12 SEC, H = 12.0 FT
 TIME INCREMENT = -0.025 TO +0.025 SEC

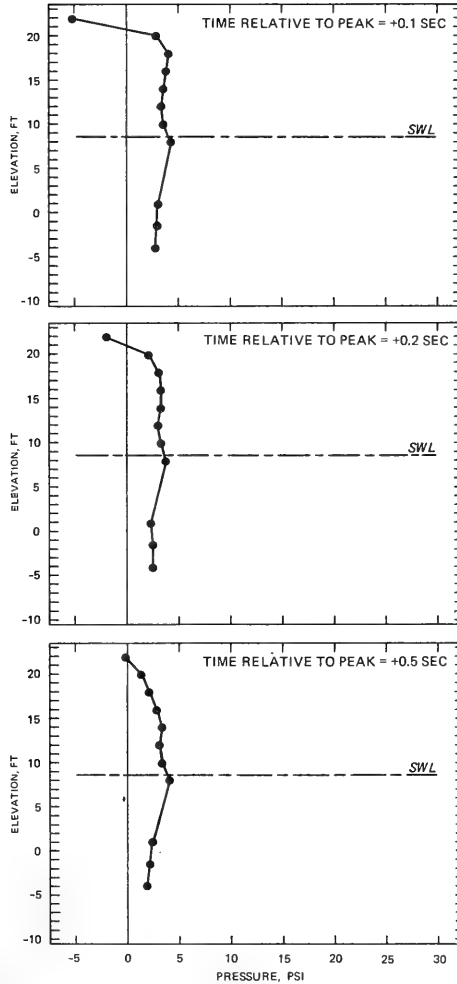

INSTANTANEOUS WAVE PRESSURE DISTRIBUTION
PLAN R4S2
SWL = +8.6 FT, T = 12 SEC, H = 12.0 FT
TIME INCREMENT = +0.1 TO +0.5 SEC

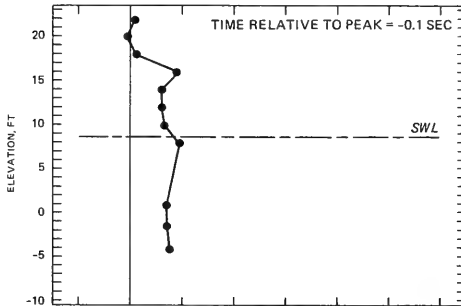
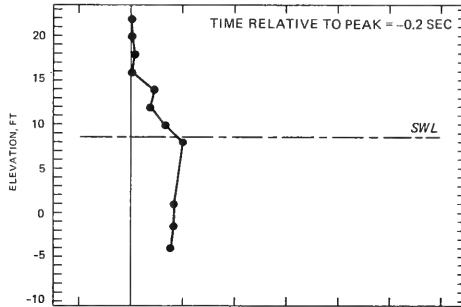
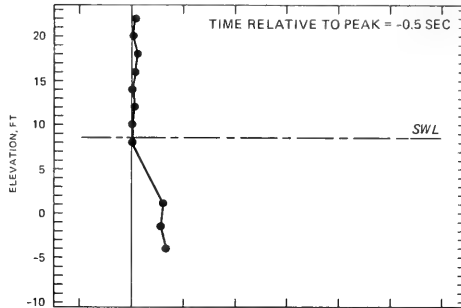

INSTANTANEOUS WAVE PRESSURE DISTRIBUTION

PLAN R4S2

SWL = +8.6 FT, T = 12 SEC, H = 14.0 FT

TIME INCREMENT = -0.5 TO -0.1 SEC

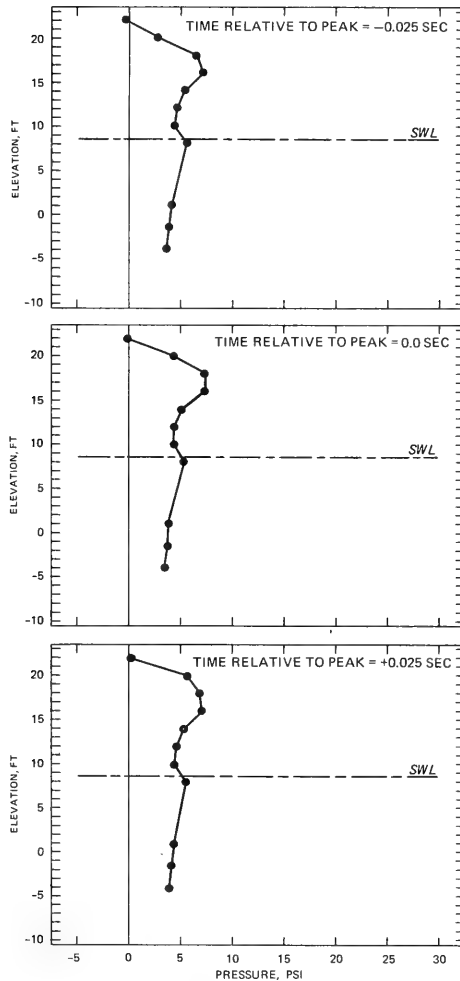

INSTANTANEOUS WAVE PRESSURE DISTRIBUTION

PLAN R4S2

SWL = +8.6 FT, T = 12 SEC, H = 14.0 FT
 TIME INCREMENT = -0.025 TO +0.025 SEC

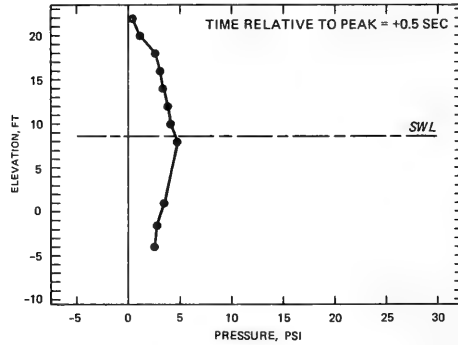
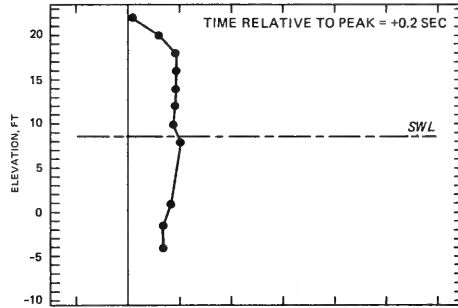
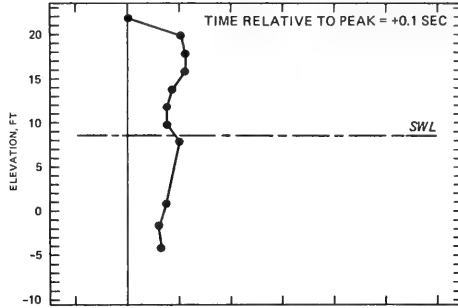

INSTANTANEOUS WAVE PRESSURE DISTRIBUTION

PLAN R4S2

SWL = +8.6 FT, T = 12 SEC, H = 14.0 FT

TIME INCREMENT = +0.1 TO +0.5 SEC

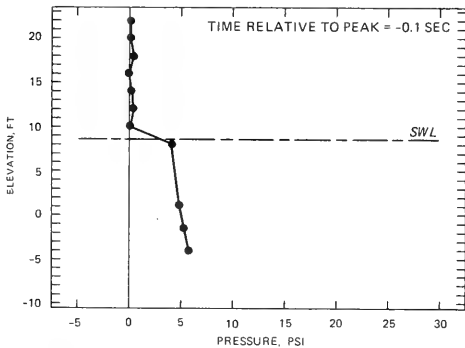
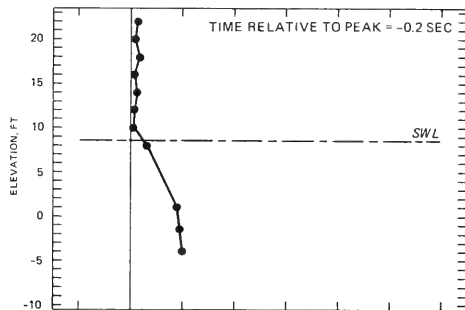
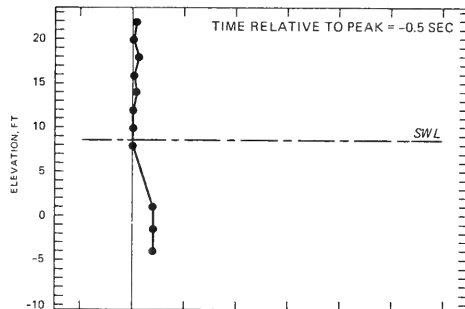

INSTANTANEOUS WAVE PRESSURE DISTRIBUTION

PLAN R4S2

SWL = +8.6 FT, T = 12 SEC, H = 16.0 FT

TIME INCREMENT = -0.5 TO -0.1 SEC

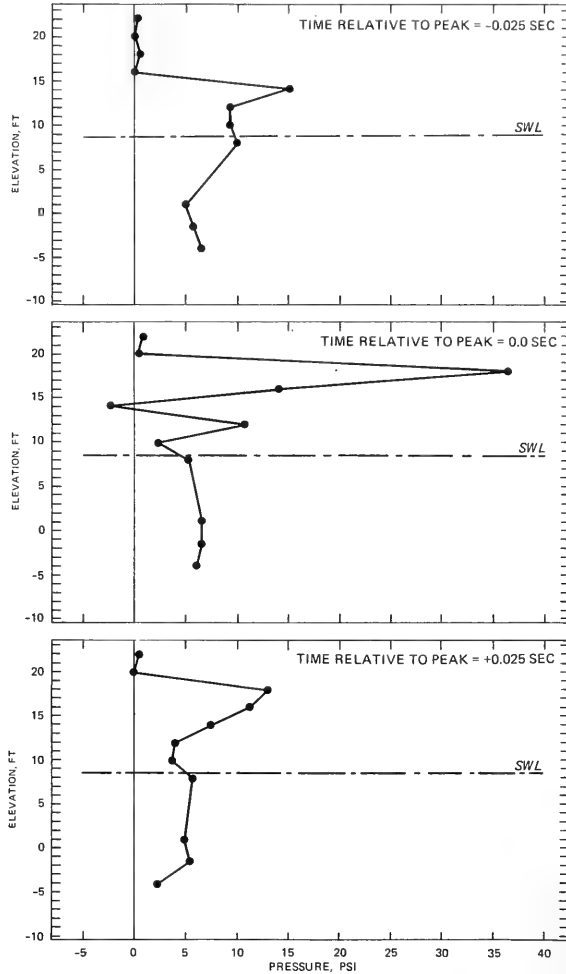

INSTANTANEOUS WAVE PRESSURE DISTRIBUTION

PLAN R4S2

SWL = +8.6 FT, T = 12 SEC, H = 16.0 FT
 TIME INCREMENT = -0.025 TO +0.025 SEC

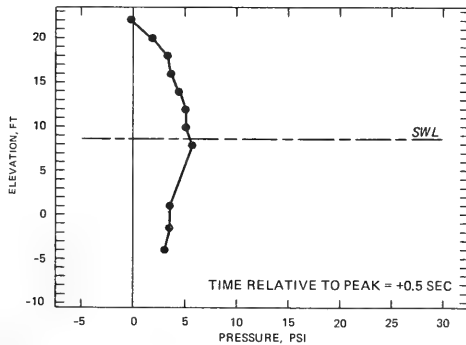
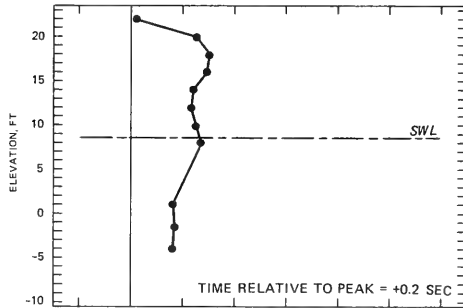
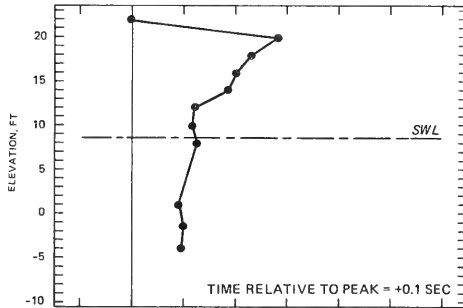

INSTANTANEOUS WAVE PRESSURE DISTRIBUTION

PLAN R4S2

SWL = +8.6 FT, T = 12 SEC, H = 16.0 FT

TIME INCREMENT = +0.1 TO +0.5 SEC

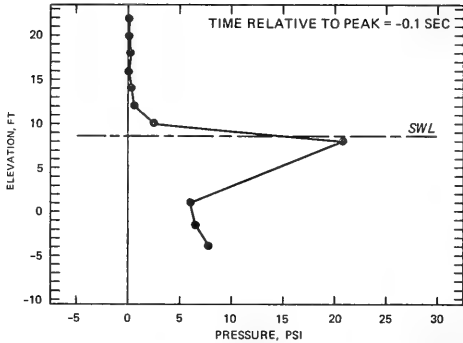
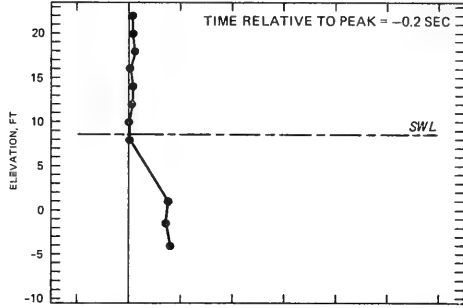
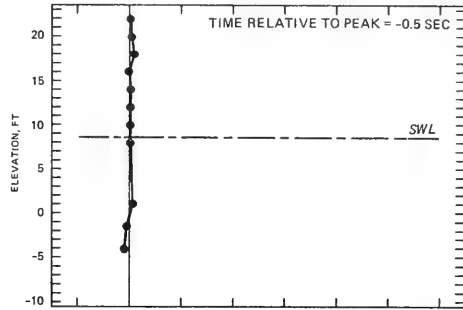

INSTANTANEOUS WAVE PRESSURE DISTRIBUTION

PLAN R4S2

SWL = +8.6 FT, T = 12 SEC, H = 16.8 FT
 TIME INCREMENT = -0.5 TO -0.1 SEC

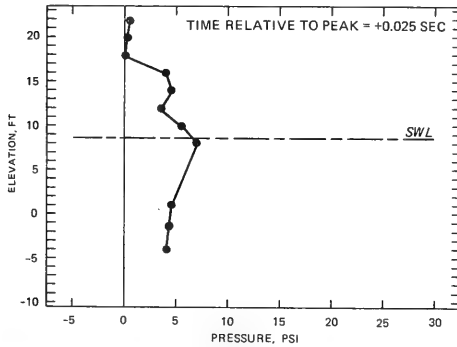
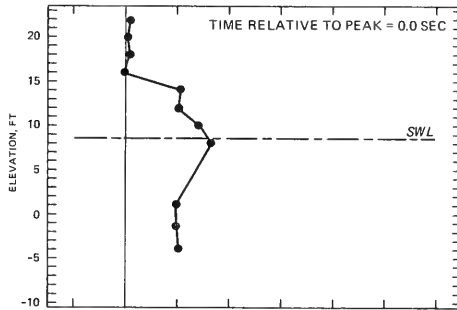
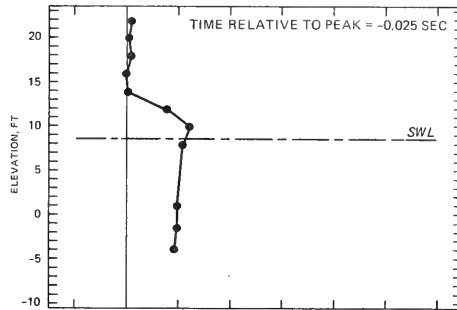

INSTANTANEOUS WAVE PRESSURE DISTRIBUTION
 PLAN R4S2
 SWL = +8.6 FT, T = 12 SEC, H = 16.8 FT
 TIME INCREMENT = -0.025 TO +0.025 SEC

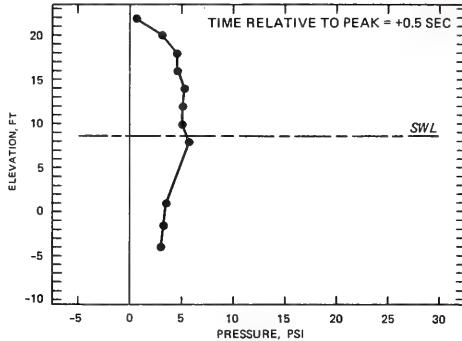
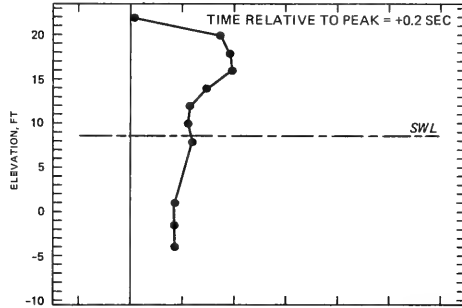
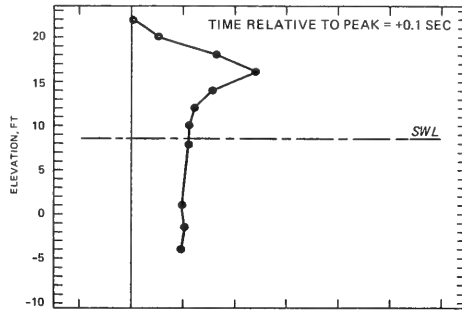

INSTANTANEOUS WAVE PRESSURE DISTRIBUTION

PLAN R4S2

SWL = +8.6 FT, T = 12 SEC, H = 16.8 FT

TIME INCREMENT = +0.1 TO +0.5 SEC

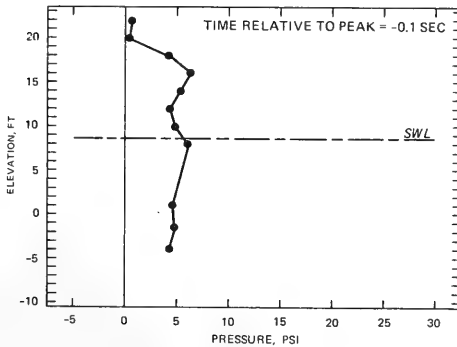
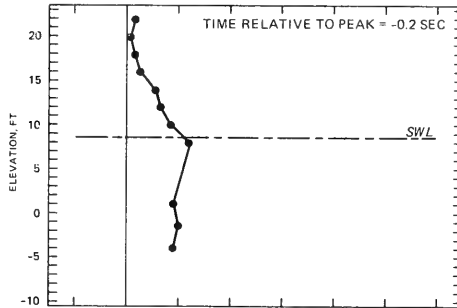
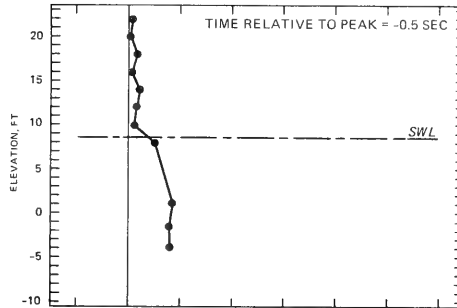

INSTANTANEOUS WAVE PRESSURE DISTRIBUTION

PLAN R4S2

SWL = +8.6 FT, T = 14 SEC, H = 12.0 FT

TIME INCREMENT = -0.5 TO -0.1 SEC

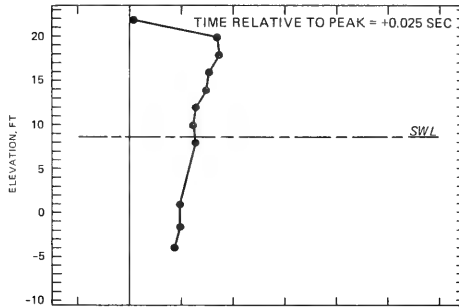
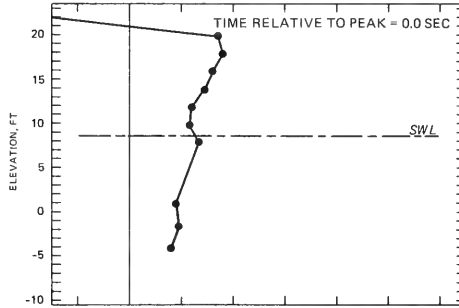
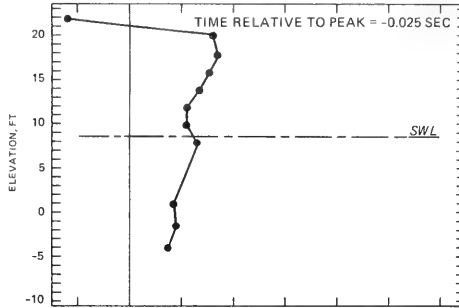

INSTANTANEOUS WAVE PRESSURE DISTRIBUTION

PLAN R4S2

SWL = +8.6 FT, T = 14 SEC, H = 12.0 FT
 TIME INCREMENT = -0.025 TO +0.025 SEC

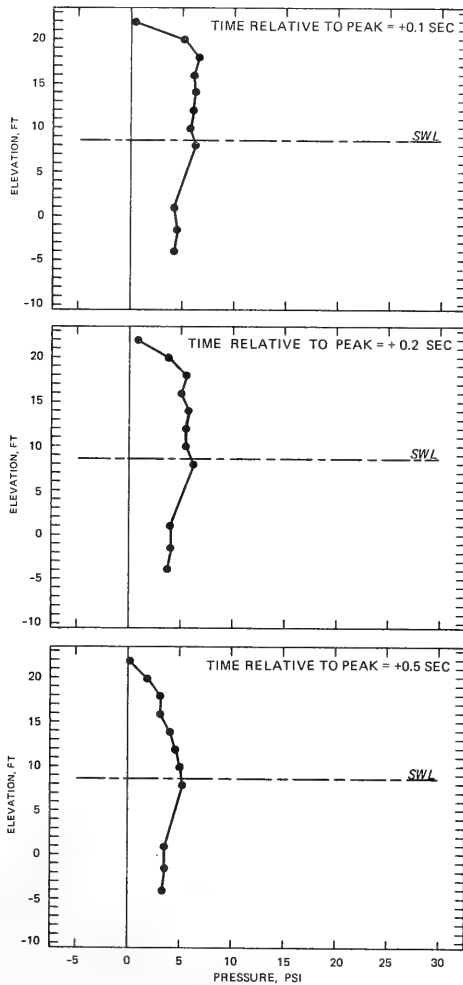

INSTANTANEOUS WAVE PRESSURE DISTRIBUTION

PLAN R4S2

SWL = +8.6 FT, T = 14 SEC, H = 12.0 FT

TIME INCREMENT = +0.1 TO +0.5 SEC

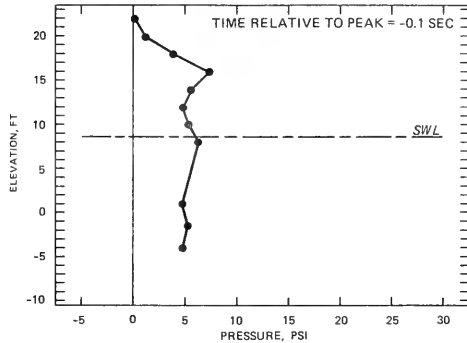
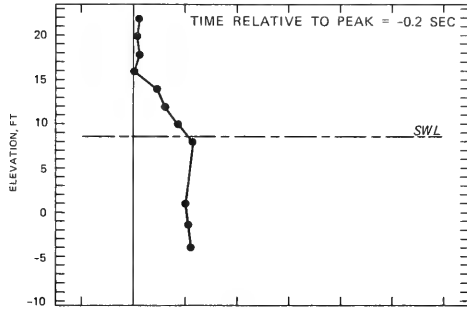
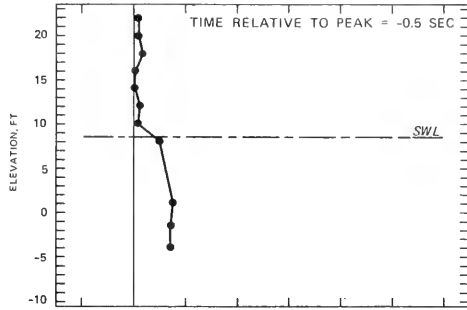

INSTANTANEOUS WAVE PRESSURE DISTRIBUTION

PLAN R4S2

SWL = +8.6 FT, T = 14 SEC, H = 14.0 FT

TIME INCREMENT = -0.5 TO -0.1 SEC

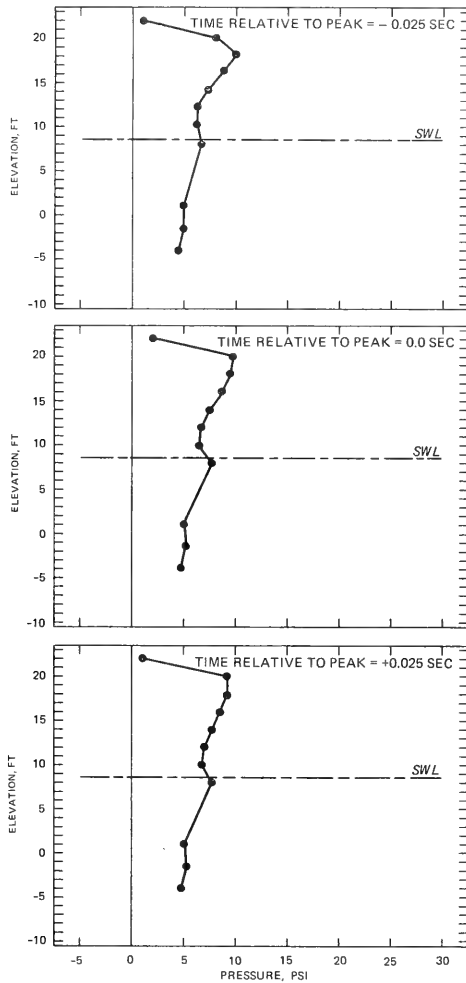

INSTANTANEOUS WAVE PRESSURE DISTRIBUTION

PLAN R4S2

SWL = +8.6 FT, T = 14 SEC, H = 14.0 FT
 TIME INCREMENT = -0.025 TO +0.025 SEC

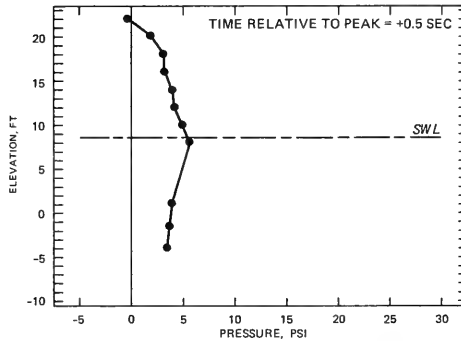
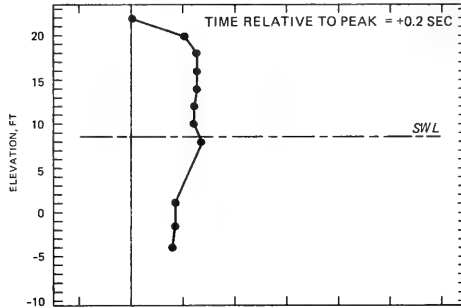
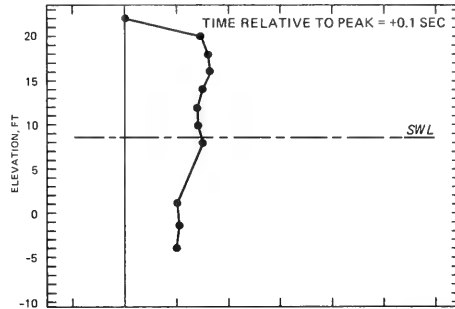

INSTANTANEOUS WAVE PRESSURE DISTRIBUTION

PLAN R4S2

SWL = +8.6 FT, T = 14 SEC, H = 14.0 FT

TIME INCREMENT = +0.1 TO +0.5 SEC

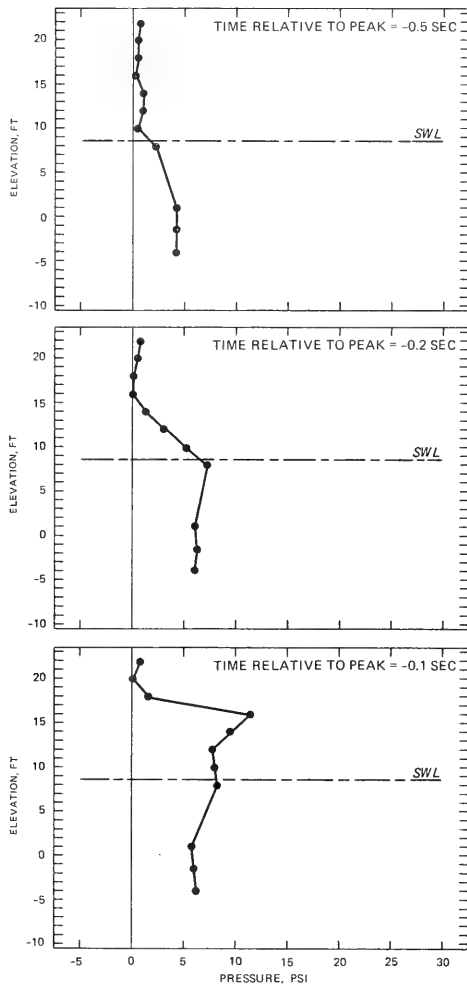

INSTANTANEOUS WAVE PRESSURE DISTRIBUTION

PLAN R4S2

SWL = +8.6 FT, T = 14 SEC, H = 17.0 FT

TIME INCREMENT = -0.5 TO -0.1 SEC

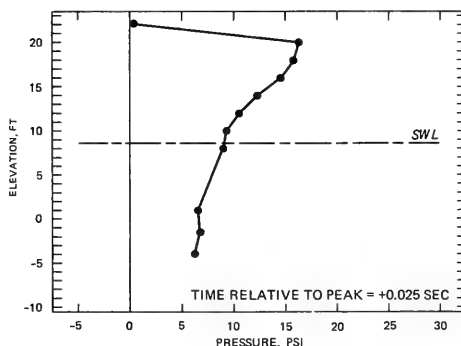
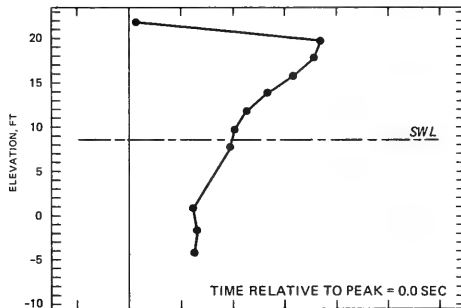
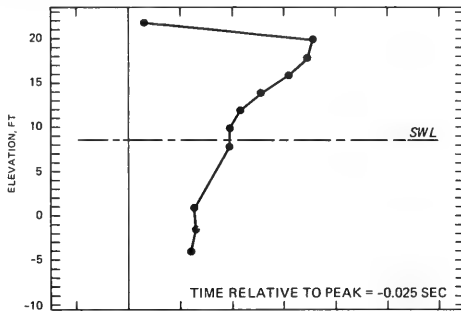

INSTANTANEOUS WAVE PRESSURE DISTRIBUTION
 PLAN R4S2
 SWL = +8.6 FT, T = 14 SEC, H = 17.0 FT
 TIME INCREMENT = -0.025 TO +0.025 SEC

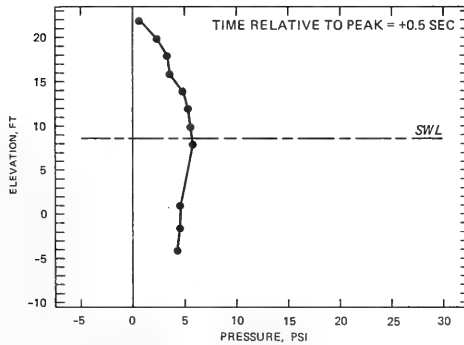
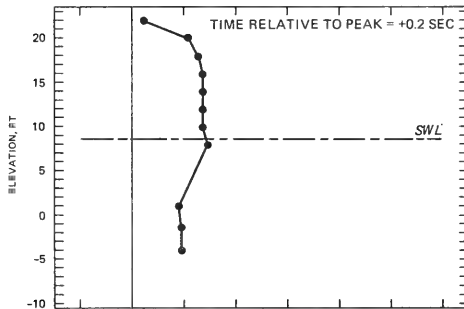
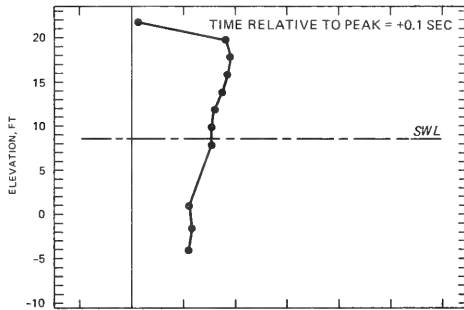

INSTANTANEOUS WAVE PRESSURE DISTRIBUTION

PLAN R4S2

SWL = +8.6 FT, T = 14 SEC, H = 17.0 FT

TIME INCREMENT = +0.1 TO +0.5 SEC

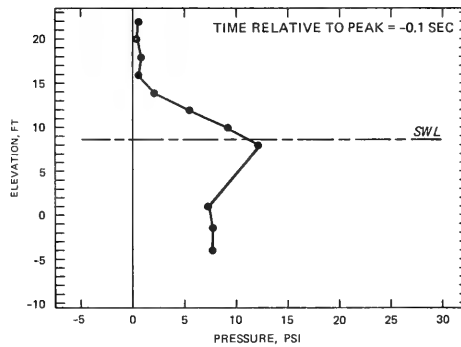
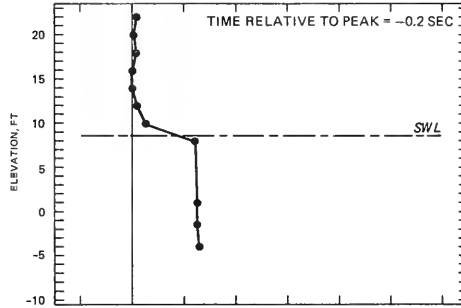
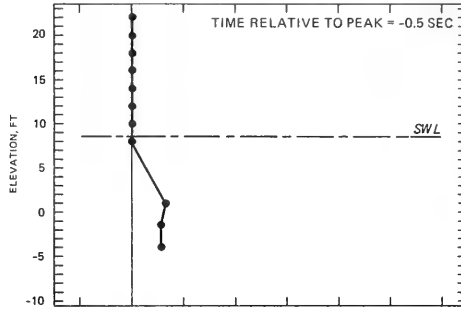

INSTANTANEOUS WAVE PRESSURE DISTRIBUTION
 PLAN R4S2
 SWL = +8.6 FT, T = 14 SEC, H = 11.4 FT
 TIME INCREMENT = -0.5 TO -0.1 SEC

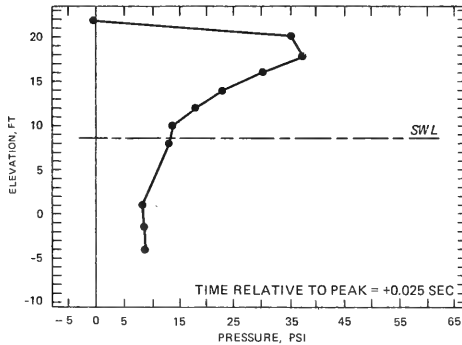
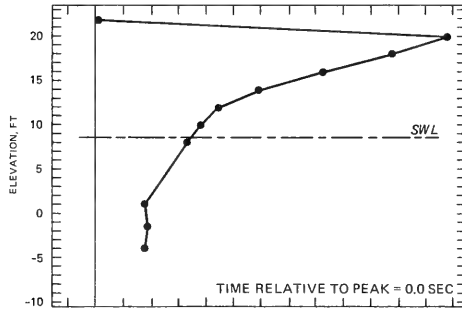
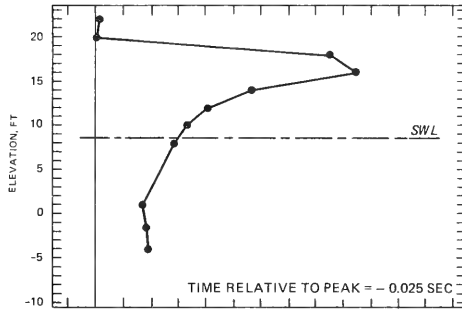

INSTANTANEOUS WAVE PRESSURE DISTRIBUTION
 PLAN R4S2
 SWL = +8.6 FT, T = 14 SEC, H = 11.4 FT
 TIME INCREMENT = -0.025 SEC TO +0.025 SEC

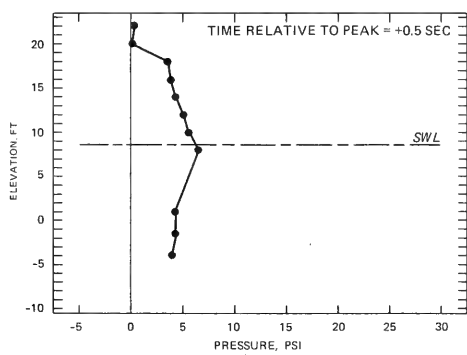
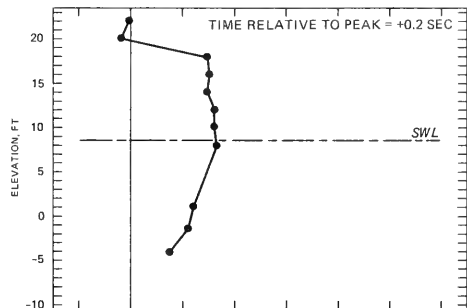
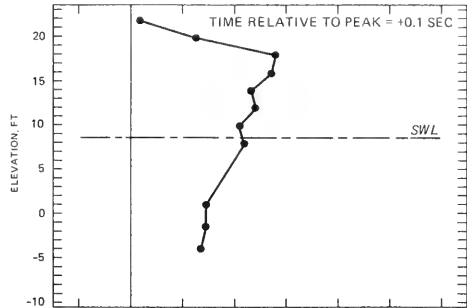

INSTANTANEOUS WAVE PRESSURE DISTRIBUTION

PLAN R4S2

SWL = +8.6 FT, T = 14 SEC, H = 11.4 FT
 TIME INCREMENT = +0.1 TO +0.5 SEC

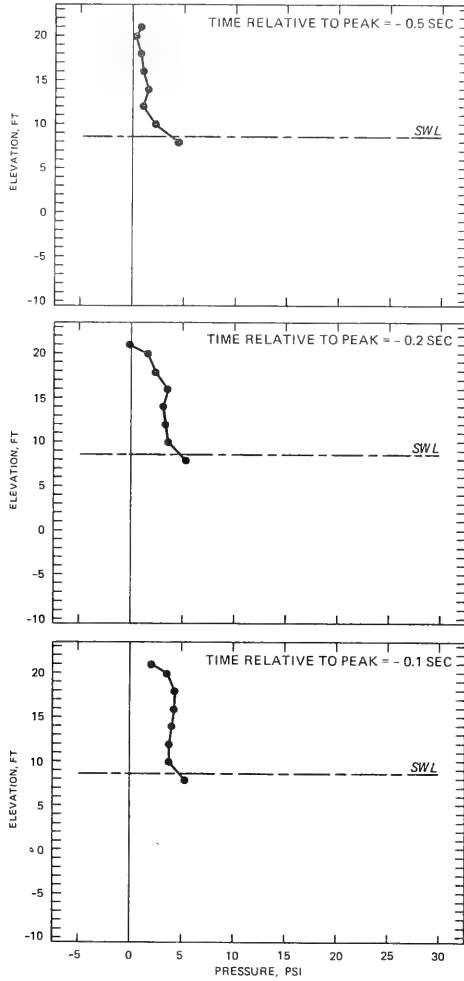

INSTANTANEOUS WAVE PRESSURE DISTRIBUTION

PLAN R4S3

SWL = +8.6 FT, T = 12 SEC, H = 12.0 FT

TIME INCREMENT = -0.5 TO -0.1 SEC

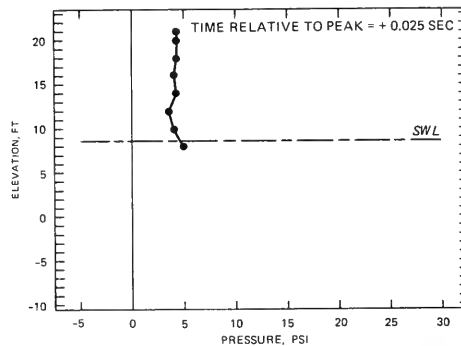
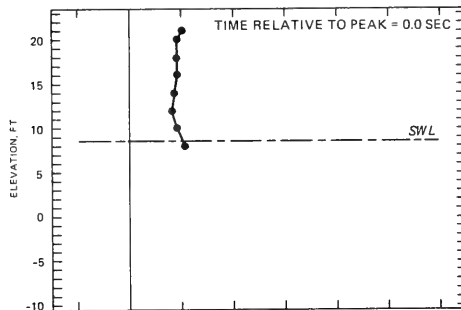
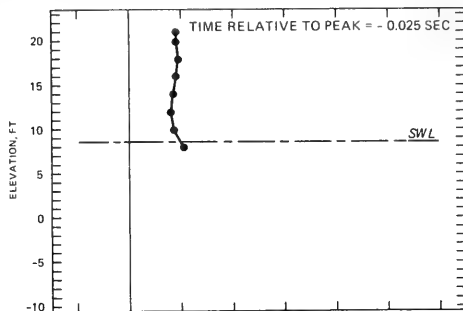

INSTANTANEOUS WAVE PRESSURE DISTRIBUTION

PLAN R4S3

SWL = +8.6 FT, T = 12 SEC, H = 12.0 FT
 TIME INCREMENT = -0.025 TO +0.025 SEC

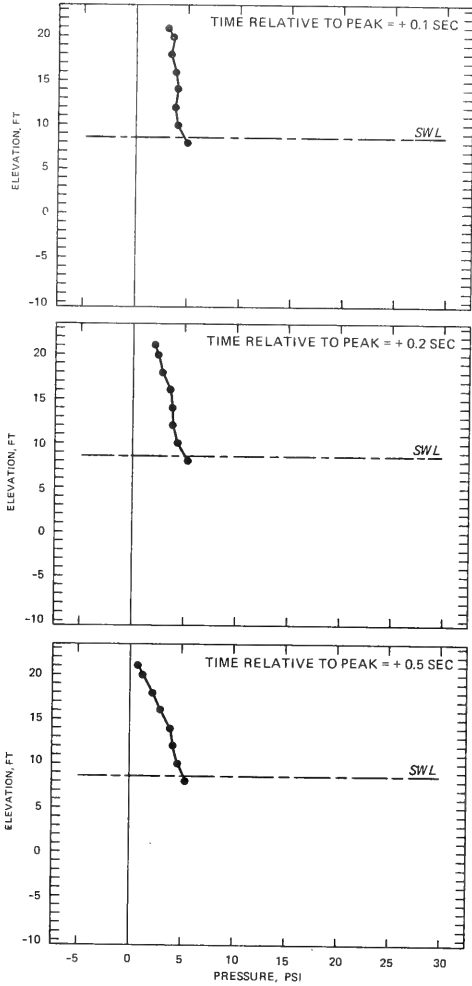

INSTANTANEOUS WAVE PRESSURE DISTRIBUTION

PLAN R4S3

SWL = +8.6 FT, T = 12 SEC, H = 12.0 FT

TIME INCREMENT = +0.1 TO +0.5 SEC

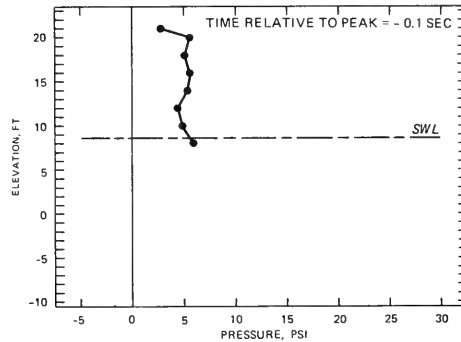
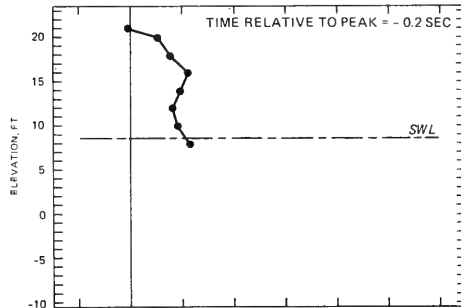
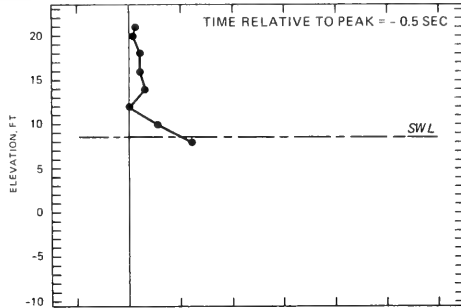

INSTANTANEOUS WAVE PRESSURE DISTRIBUTION

PLAN R4S3

SWL = +8.6 FT, T = 12 SEC, H = 14.0 FT

TIME INCREMENT = -0.5 TO -0.1 SEC

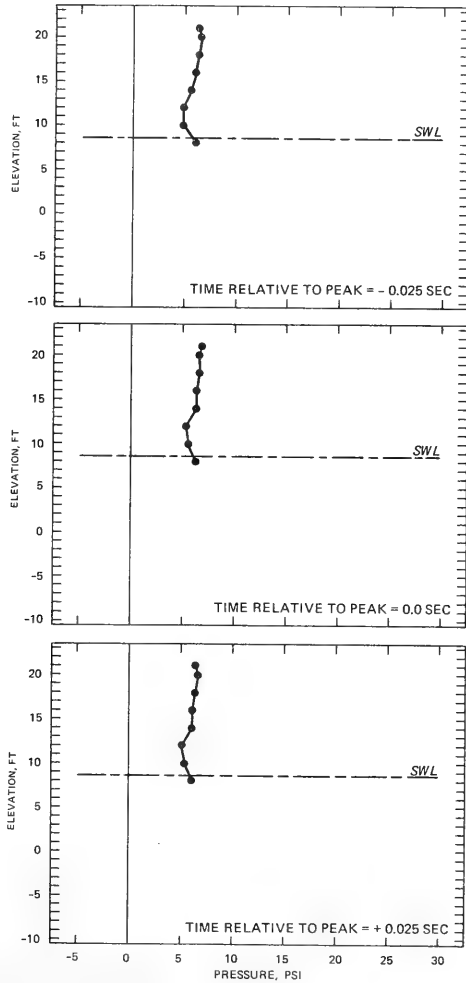

INSTANTANEOUS WAVE PRESSURE DISTRIBUTION

PLAN R4S3

SWL = +8.6 FT, T = 12 SEC, H = 14.0 FT
 TIME INCREMENT = -0.025 TO +0.025 SEC

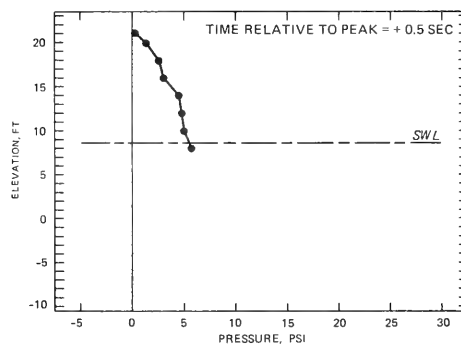
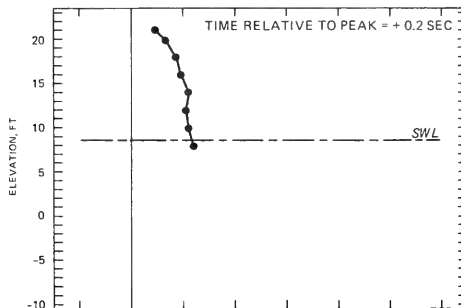
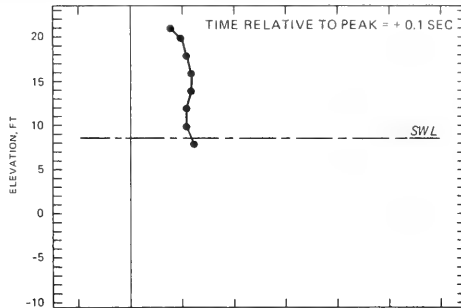

INSTANTANEOUS WAVE PRESSURE DISTRIBUTION

PLAN R4S3

SWL = +8.6 FT, T = 12 SEC, H = 14.0 FT

TIME INCREMENT = +0.1 TO +0.5 SEC

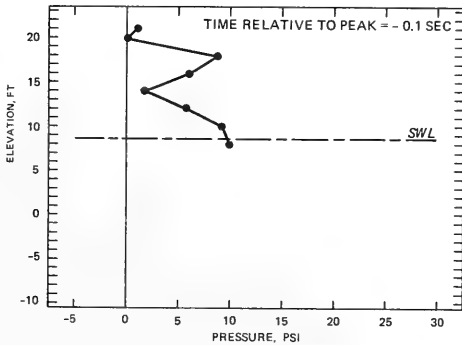
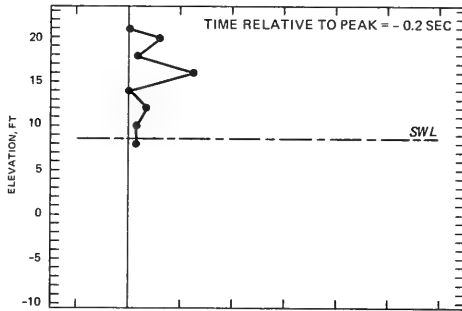
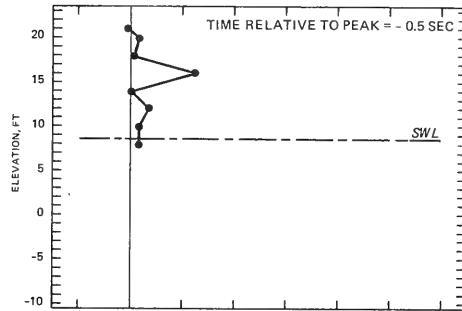

INSTANTANEOUS WAVE PRESSURE DISTRIBUTION

PLAN R4S3

SWL = +8.6 FT, T = 12 SEC, H = 16.0 FT

TIME INCREMENT = -0.5 TO -0.1 SEC

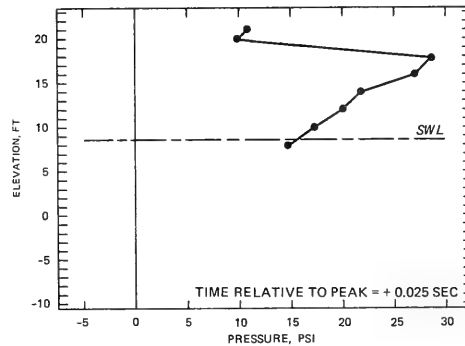
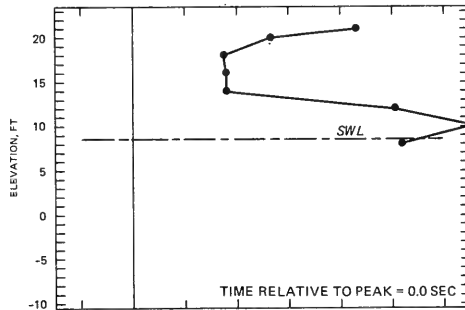
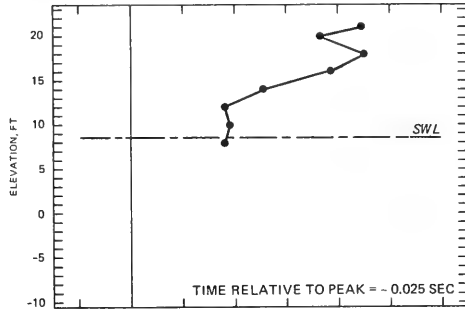

INSTANTANEOUS WAVE PRESSURE DISTRIBUTION

PLAN R4S3

SWL = +8.6 FT, T = 12 SEC, H = 16.0 FT
 TIME INCREMENT = -0.025 TO +0.025 SEC

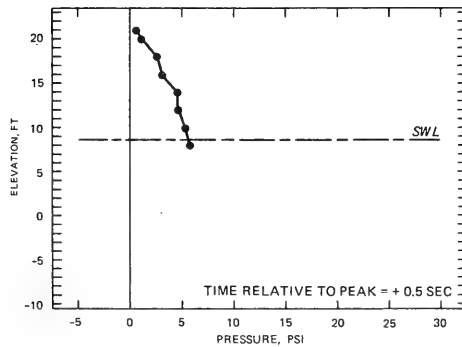
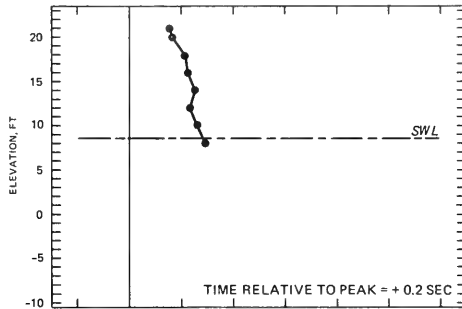
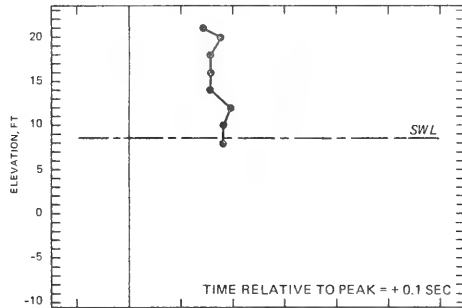

INSTANTANEOUS WAVE PRESSURE DISTRIBUTION

PLAN R4S3

SWL = +8.6 FT, T = 12 SEC, H = 16.0 FT

TIME INCREMENT = +0.1 TO +0.5 SEC

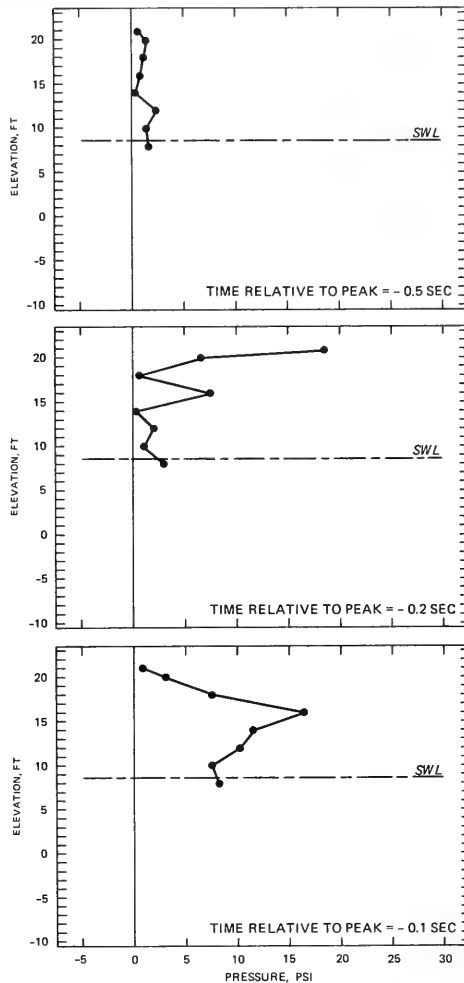

INSTANTANEOUS WAVE PRESSURE DISTRIBUTION

PLAN R4S3

SWL = +8.6 FT, T = 12 SEC, H = 16.8 FT
 TIME INCREMENT = -0.5 TO -0.1 SEC

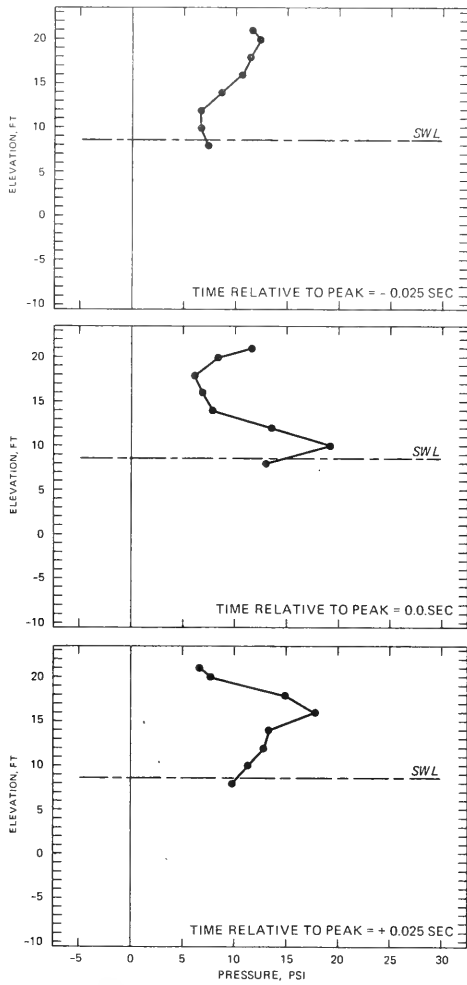

INSTANTANEOUS WAVE PRESSURE DISTRIBUTION

PLAN R4S3

SWL = +8.6 FT, T = 12 SEC, H = 16.8 FT

TIME INCREMENT = -0.025 TO +0.025 SEC

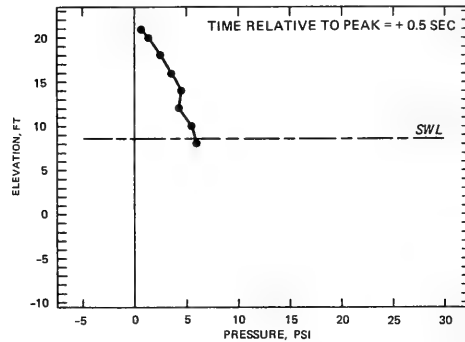
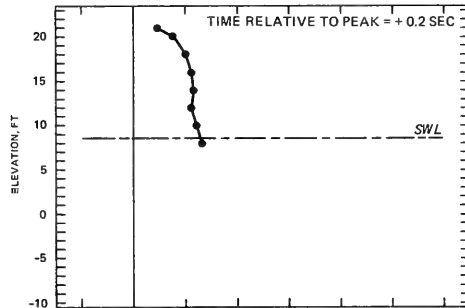
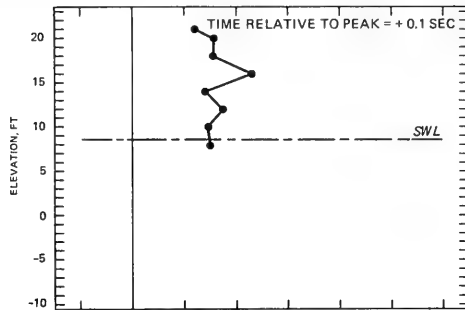

INSTANTANEOUS WAVE PRESSURE DISTRIBUTION

PLAN R4S3

SWL = +8.6 FT, T = 12 SEC, H = 16.8 FT
 TIME INCREMENT = +0.1 TO +0.5 SEC

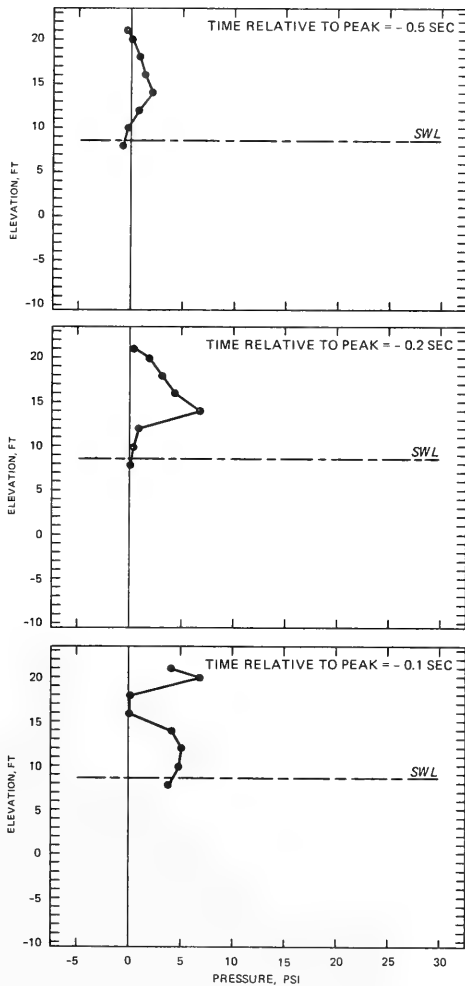

INSTANTANEOUS WAVE PRESSURE DISTRIBUTION

PLAN R4S3

SWL = +8.6 FT, T = 14 SEC, H = 12.0 FT

TIME INCREMENT = -0.5 TO -0.1 SEC

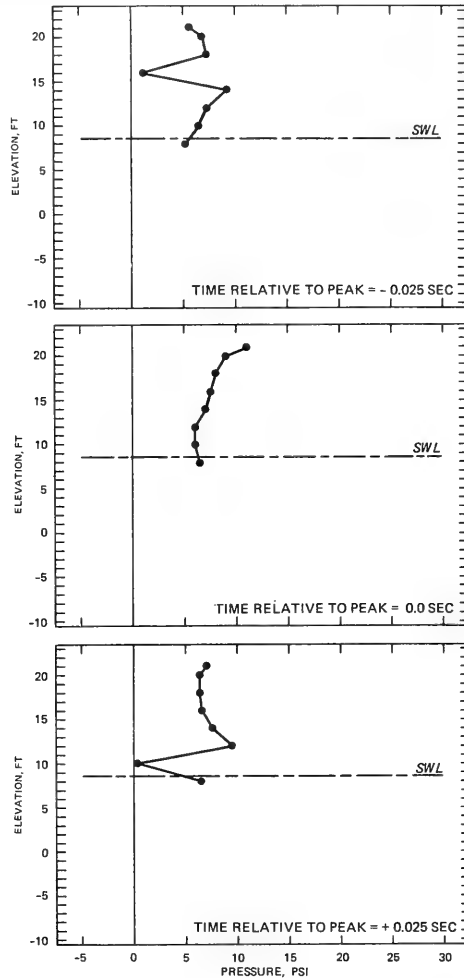

INSTANTANEOUS WAVE PRESSURE DISTRIBUTION

PLAN R4S3

SWL = +8.6 FT, T = 14 SEC, H = 12.0 FT
 TIME INCREMENT = -0.025 TO +0.025 SEC

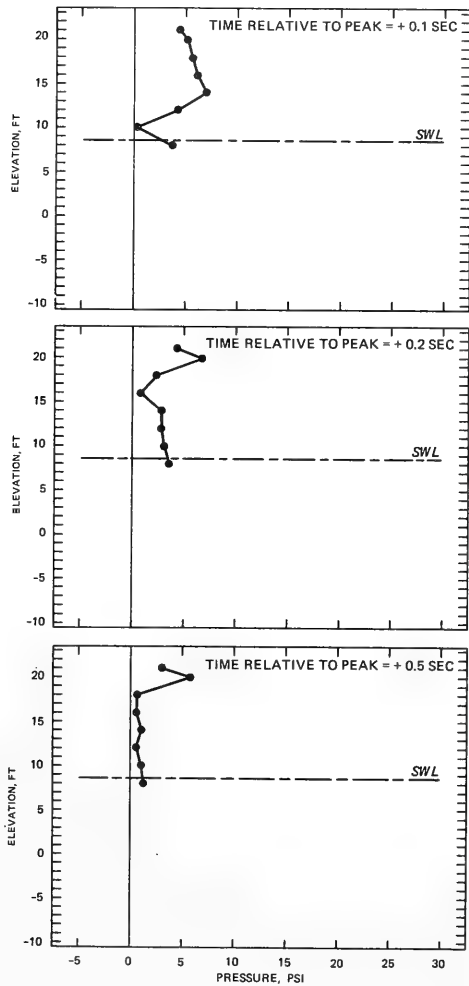

INSTANTANEOUS WAVE PRESSURE DISTRIBUTION

PLAN R4S3

SWL = +8.6 FT, T = 14 SEC, H = 12.0 FT
 TIME INCREMENT = +0.1 TO +0.5 SEC

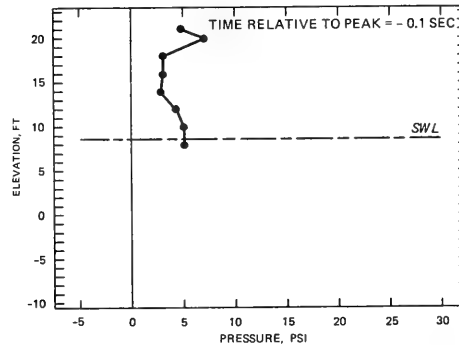
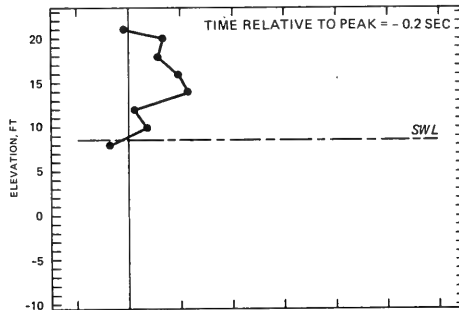
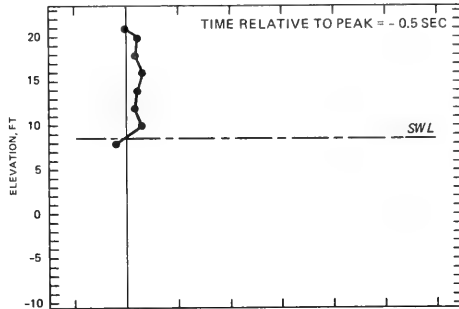

INSTANTANEOUS WAVE PRESSURE DISTRIBUTION

PLAN R4S3

SWL = +8.6 FT, T = 14 SEC, H = 14.0 FT

TIME INCREMENT = -0.5 TO -0.1 SEC

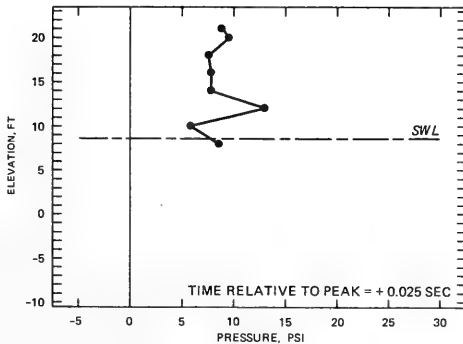
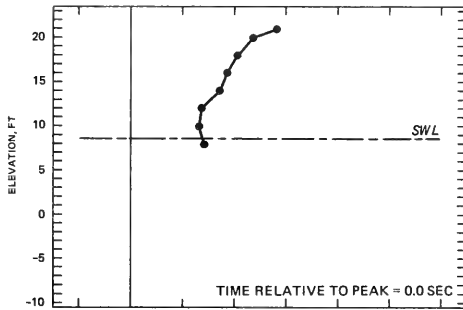
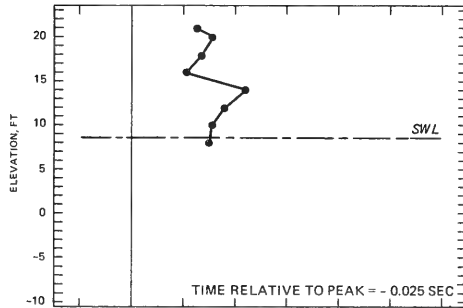

INSTANTANEOUS WAVE PRESSURE DISTRIBUTION
PLAN R4S3

SWL = +8.6 FT, T = 14 SEC, H = 14.0 FT
TIME INCREMENT = -0.025 TO +0.025 SEC

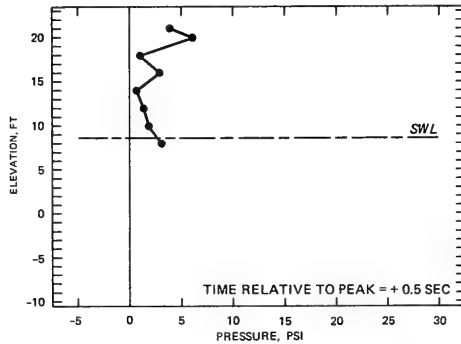
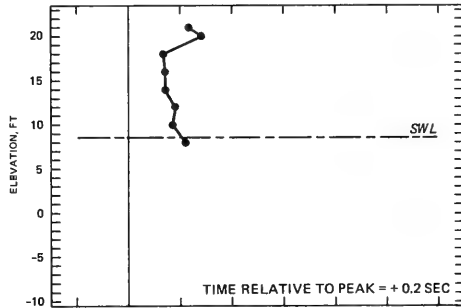
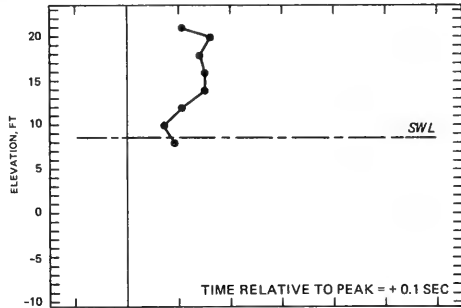

INSTANTANEOUS WAVE PRESSURE DISTRIBUTION

PLAN R4S3

SWL = +8.6 FT, T = 14 SEC, H = 14.0 FT

TIME INCREMENT = +0.1 TO +0.5 SEC

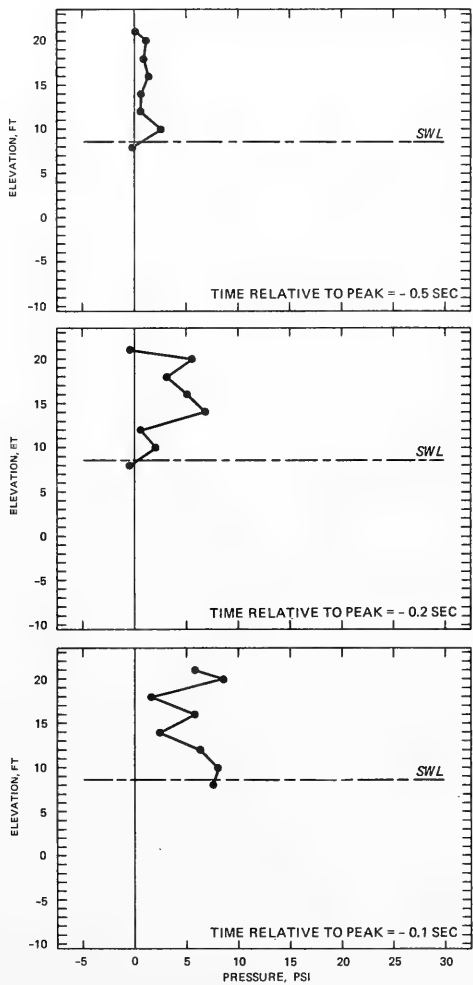

INSTANTANEOUS WAVE PRESSURE DISTRIBUTION
 PLAN R4S3
 SWL = +8.6 FT, T = 14 SEC, H = 17.0 FT
 TIME INCREMENT = -0.5 TO -0.1 SEC

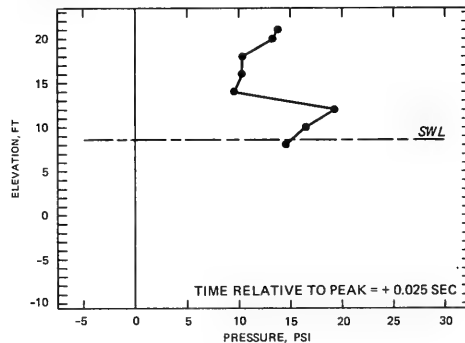
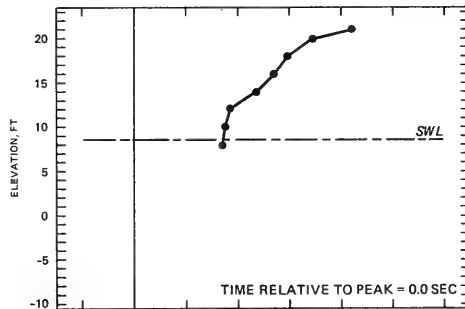
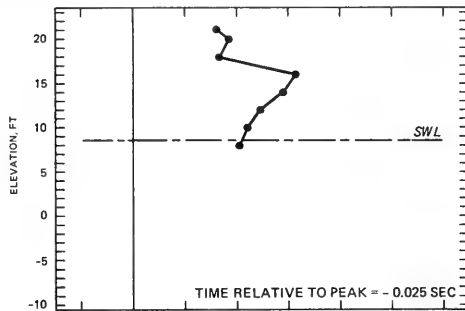

INSTANTANEOUS WAVE PRESSURE DISTRIBUTION

PLAN R4S3

SWL = +8.6 FT, T = 14 SEC, H = 17.0 FT
 TIME INCREMENT = -0.025 TO +0.025 SEC

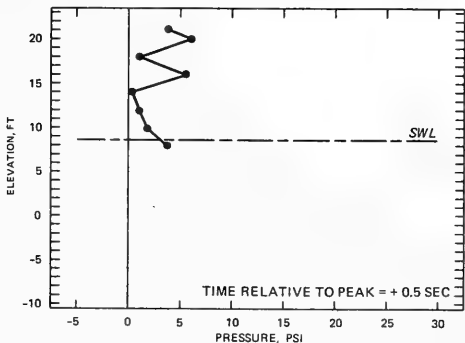
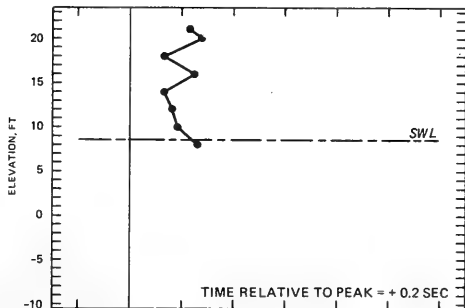
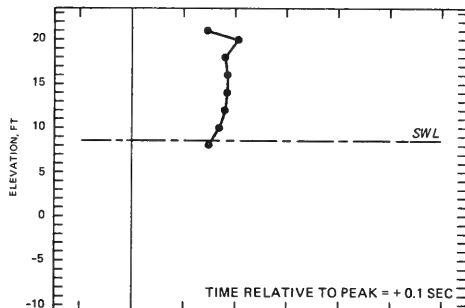

INSTANTANEOUS WAVE PRESSURE DISTRIBUTION

PLAN R4S3

SWL = +8.6 FT, T = 14 SEC, H = 17.0 FT

TIME INCREMENT = +0.1 TO +0.5 SEC

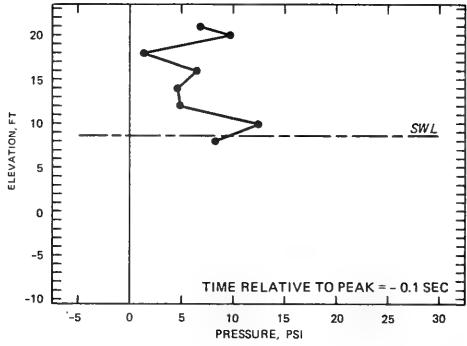
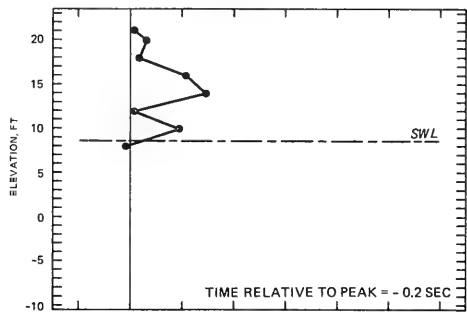
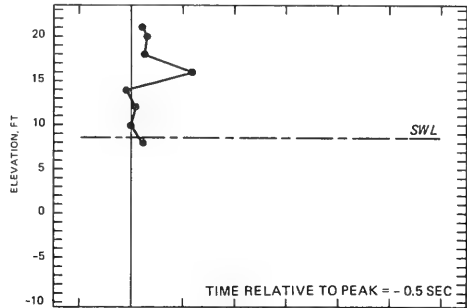

INSTANTANEOUS WAVE PRESSURE DISTRIBUTION
 PLAN R4S3
 SWL = +8.6 FT T = 14 SEC, H = 11.4 FT
 TIME INCREMENT = -0.5 TO -0.1 SEC

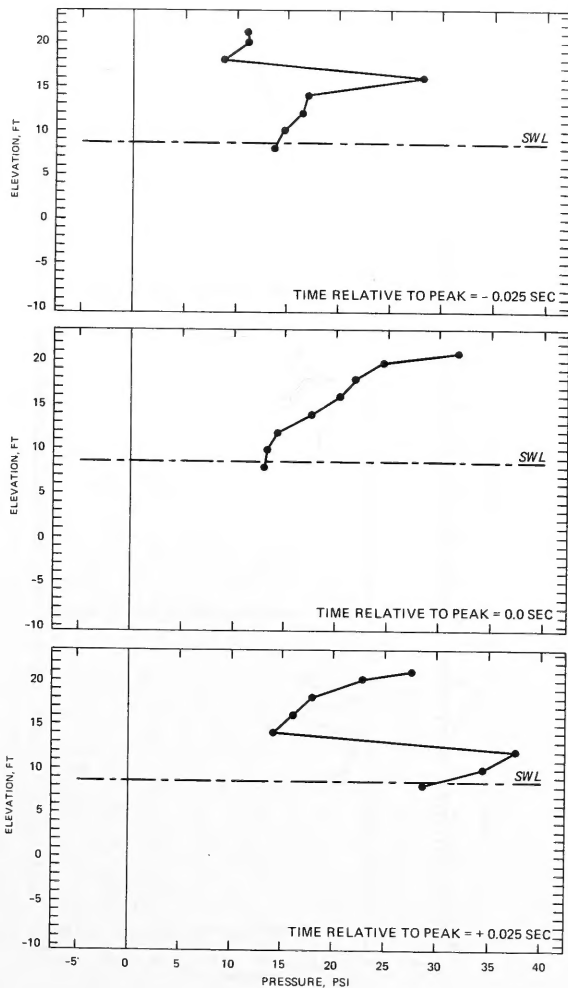

INSTANTANEOUS WAVE PRESSURE DISTRIBUTION

PLAN R4S3

SWL = +8.6 FT T = 14 SEC, H = 11.4 FT
 TIME INCREMENT = -0.025 TO +0.025 SEC

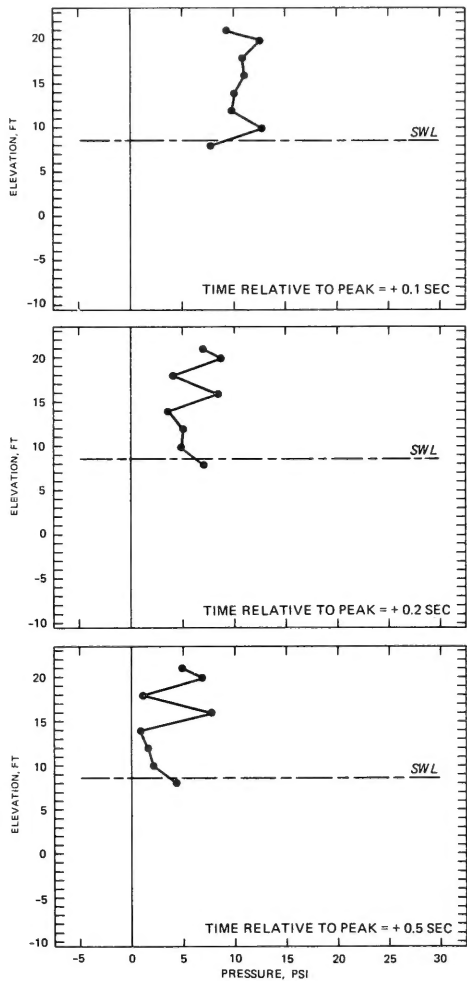

INSTANTANEOUS WAVE PRESSURE DISTRIBUTION

PLAN R4S3

SWL = +8.6 FT, T = 14 SEC, H = 11.4 FT
 TIME INCREMENT = +0.1 TO +0.5 SEC

