

the

Marine Biological Library

MBL/WHOI



0 0301 0019940 2



THIRD EDITION

SEX AND  
INTERNAL  
SECRETIONS

VOLUME I

# VOLUME I

## CONTRIBUTORS

A. Albert  
David W. Bishop  
Richard J. Blandau  
R. K. Burns  
A. T. Cowie  
John W. Everett  
S. J. Folley  
Thomas R. Forbes  
J. W. Gowen

Roy O. Greep  
A. M. Guhl  
Joan G. Hampson  
John L. Hampson  
Frederick L. Hisaw  
Frederick L. Hisaw, Jr.  
James H. Leatham  
Daniel S. Lehrman  
Margaret Mead  
John W. Money

Helen Padykula  
Dorothy Price  
Herbert D. Purves  
Ari van Tienhoven  
Claude A. Villee  
H. Guy Williams-Ashman  
George B. Wislocki  
William C. Young  
M. A. Zarrow

Baltimore • 1961



577.01521  
Y 88

THIRD EDITION

# SEX AND INTERNAL SECRETIONS

*Edited by* William C. Young, Ph.D.  
Professor of Anatomy, University of Kansas, Lawrence

*Foreword by* George W. Corner, M.D., D.Sc.  
Director Emeritus, Department of Embryology,  
Carnegie Institution of Washington

The Williams & Wilkins Co.

Publication was supported in part by  
Public Health Service Research Grant M-4648 from  
the National Institute of Mental Health,  
Public Health Service.

Copyright ©, 1961  
THE WILLIAMS & WILKINS COMPANY

*Made in the United States of America*

Library of Congress  
Catalog Card Number  
60-12279

COMPOSED AND PRINTED BY THE  
WAVERLY PRESS, INC.  
BALTIMORE, 2, MARYLAND, U.S.A.



*To the Memory of*

**Robert Mearns Yerkes**



# CONTENTS

## Volume I

Foreword, <i>George W. Corner</i> .....	ix
Edgar Allen, <i>William C. Young</i> .....	xiii
Preface to Third Edition.....	xvi
Preface to First Edition.....	xxiii

### SECTION A

#### BIOLOGIC BASIS OF SEX

1. Cytologic and Genetic Basis of Sex. <i>J. W. Gowen</i> .....	3
2. Role of Hormones in the Differentiation of Sex. <i>R. K. Burns</i> .....	76

### SECTION B

#### THE HYPOPHYSIS AND THE GONADOTROPHIC HORMONES IN RELATION TO REPRODUCTION

3. Morphology of the Hypophysis Related to Its Function. <i>Herbert D. Purves</i> .....	161
4. Physiology of the Anterior Hypophysis in Relation to Reproduction. <i>Roy O. Greep</i> .....	240

### SECTION C

#### PHYSIOLOGY OF THE GONADS AND ACCESSORY ORGANS

5. The Mammalian Testis. <i>A. Albert</i> .....	305
6. The Accessory Reproductive Glands of Mammals. <i>Dorothy Price and H. Guy Williams-Ashman</i> .....	366
7. The Mammalian Ovary. <i>William C. Young</i> .....	449
8. The Mammalian Female Reproductive Cycle and Its Controlling Mechanisms. <i>John W. Everett</i> .....	497
9. Action of Estrogen and Progesterone on the Reproductive Tract of Lower Primates. <i>Frederick L. Hisaw and Frederick L. Hisaw, Jr.</i> .....	556
10. The Mammary Gland and Lactation. <i>A. T. Cowie and S. J. Folley</i> .....	590
11. Some Problems of the Metabolism and Mechanism of Action of Steroid Sex Hormones. <i>Claude A. Villee</i> .....	643
12. Nutritional Effects on Endocrine Secretions. <i>James H. Leatham</i> .....	666

## Volume II

### SECTION D

#### BIOLOGY OF SPERM AND OVA, FERTILIZATION, IMPLANTATION, THE PLACENTA, AND PREGNANCY

13. Biology of Spermatozoa. <i>David W. Bishop</i> .....	707
14. Biology of Eggs and Implantation. <i>Richard J. Blandau</i> .....	797
15. Histochemistry and Electron Microscopy of the Placenta. <i>George B. Wislocki and Helen Padykula</i> .....	883
16. Gestation. <i>M. X. Zarrow</i> .....	958

### SECTION E

#### PHYSIOLOGY OF REPRODUCTION IN SUBMAMMALIAN VERTEBRATES

17. Endocrinology of Reproduction in Cold-blooded Vertebrates. <i>Thomas R. Forbes</i> .....	1035
18. Endocrinology of Reproduction in Birds. <i>Ari van Tienhoven</i> .....	1088

## SECTION F

## HORMONAL REGULATION OF REPRODUCTIVE BEHAVIOR

19. The Hormones and Mating Behavior. <i>William C. Young</i> .....	1173
20. Gonadal Hormones and Social Behavior in Infrahuman Vertebrates. <i>A. M. Gahl</i> .....	1240
21. Gonadal Hormones and Parental Behavior in Birds and Infrahuman Mammals. <i>Daniel S. Lehrman</i> .....	1268
22. Sex Hormones and Other Variables in Human Eroticism. <i>John W. Money</i> .....	1383
23. The Ontogenesis of Sexual Behavior in Man. <i>John L. Hampson and Joan G. Hampson</i> .....	1401
24. Cultural Determinants of Sexual Behavior. <i>Margaret Mead</i> .....	1433
Index.....	1481

# FOREWORD

*George W. Corner, M.D., D.Sc.*

DIRECTOR EMERITUS, DEPARTMENT OF EMBRYOLOGY,  
CARNEGIE INSTITUTION OF WASHINGTON

Publication of the third edition of *Sex and Internal Secretions* signalizes the accomplishment of about a half century's intensive work by investigators of many countries, among whom those of the United States have been notably active. Any such burst of discovery as this rests, of course, upon a long preceding period of more gradual progress. Taking as landmarks Regner de Graaf's recognition that the "female testis" of mammals is an egg-producing organ comparable to the ovaries of birds (1672) and Leeuwenhoek's description of the spermatozoa (1674), we can trace the continuous development of knowledge about the reproductive system down to our own times. Discovery of the actual mammalian ovum by Karl Ernst von Baer in 1827 accelerated the progress of research on the origin of the germ cells, the development and discharge of the Graafian follicle, transport and fertilization of the ovum, and implantation and development of the embryo. Such studies inevitably drew attention to the cyclic aspects of reproductive function, particularly from students of animal breeding and from faunal naturalists, who acquired a great deal of information about the estrous cycles of wild as well as domestic animals and those of the laboratory. The work of the English leaders in this kind of investigation, Walter Heape and F. H. A. Marshall, reached fruition in the latter's well known "Physiology of Reproduction," published in 1910. At this same period (1890-1910) gynecologists, especially in Germany and Austria, were putting their specialty on a scientific basis. Becoming aware of the current advances in knowledge of embryology and the biology of reproduction of mammals in general, they were seeking similar clues to the explanation of the human menstrual cycle, ostensibly so different from the estrous cycle of domestic animals. European workers, notably Hirsch-

mann and Adler, Robert Schroeder, and Robert Meyer, from about 1900 to the beginning of the first World War, put together from operating-room material a histologic description of the human cycle that became more and more clear as the embryologists related it to their understanding of the general mammalian cycle. The young sciences of psychology, psychiatry and anthropology also joined the concerted attack upon the problems of sex and reproduction. Since about 1870 European psychiatrists, led by such men as von Krafft-Ebing and Forel, had been studying sex psychology, with the aim of understanding behavior of a kind that was considered abnormal or conducive to social difficulties such as those created by prostitution and homosexuality. The way was thus opened for psychology to investigate the biologic basis of normal sex behavior. European and American anthropologists had begun to document and analyze the sex attitudes of primitive races and distant nations, and even of their own peoples. Nor must we forget the influence of the Women's Rights movement, with its fight against all forms of bondage of women and its emphasis on standards of sex behavior equally applicable to both sexes. All these new sciences and new social movements called for better understanding of basic sex physiology, which only biologists could provide.

Thus at the beginning of the 20th century and during the next decades investigation in this field became more intense. Naturalists, animal breeders, histologists, embryologists and gynecologists gradually came to understand each other's problems, and began a period of rapid advance not yet ended nor even slowed down, in which scarcely a year has passed without major contributions.

American zoologists were already prepared by their embryologic studies to take part

in this exploration, and the rapid development of medical research in the United States in the early part of the 20th century provided specialists in human embryology, pathologists, physiologists, and biochemists who were ready to join the biologists in such investigations. When in 1922 the National Research Council was called upon by influential groups centered in the American Social Hygiene Association, to bring together existing knowledge and to promote research upon human sex behavior and reproduction, our nation already possessed a corps of competent investigators who rallied to the call of Robert M. Yerkes and Frank R. Lillie, forming the Committee for Research in Problems of Sex. This Committee, with financial support from the Rockefeller Foundation, successfully undertook to encourage research on a wide range of problems of sex physiology and behavior.

The younger readers of this book will hardly be able to appreciate the full significance of such an alliance between biologists, psychologists, and physicians on one hand, and social philanthropists on the other. It represented a major break from the so-called Victorian attitude which in the English-speaking countries had long impeded scientific and sociologic investigation of sexual matters and had placed taboos on open consideration of human mating and childbearing as if these essential activities were intrinsically indecent. To investigate such matters, even in the laboratory with rats and rabbits, required of American scientists, including some of the contributors to the first edition of *Sex and Internal Secretions*, a certain degree of moral stamina. A member of the Yerkes Committee once heard himself introduced by a fellow scientist to a new acquaintance as one of the men who had "made sex respectable." Certainly the prestige of the Committee and the successes of American investigators working with and without its assistance helped to bring about a more realistic attitude toward sex research, although reactions from some quarters to such important recent work as that of the late Alfred C. Kinsey show that the battle is even yet not fully won.

Ten years after its formation the Committee for Research in Problems of Sex,

proud of the achievements it had helped to foster, sponsored the first edition of *Sex and Internal Secretions*. The information thus brought together in 1932 came largely from research in genetics, cytology, embryology, and endocrinology, almost exclusively utilizing morphologic methods of study. In contrast to the present situation as reflected in the third edition, biochemistry of the sex glands was still in an elementary stage, having barely achieved the preliminary chemical identification of the ovarian, placental, and testicular hormones; and the psychology of sex behavior was only beginning to develop its experimental methods. The sum total was, however, a deeply impressive record of progress that drew many new workers into this field of research.

It would be difficult to ascribe priority in this achievement to any one of the biologic disciplines. Genetics and cytology had provided one of the major clues by C. E. McClung's discovery in 1902 of the significance of the accessory chromosome, and his brilliant conjecture that this minute fragment of protoplasm is related to the determination of sex. Coming just before an outburst of discoveries concerning the chromosomal mechanism of heredity, based largely on the fruit fly *Drosophila*, the concept of genetic determination of sex gave rise to an immense amount of investigation and theorizing about the way in which a developing individual is caused to become either male or female. Three decades after the publication of McClung's hypothesis, enough information on this question was in hand to fill two crowded chapters in the first edition of *Sex and Internal Secretions*.

The contribution of embryology to our subject goes back to the 18th and 19th centuries and in particular to the description of the early stages of development of the internal reproductive system, with which the names of Kaspar Friedrich Wolff and Johannes Müller are indelibly associated. In this field, too, a period of active investigation began early in the 20th century, with the aid of improved methods of microtomy and the application of precise histologic staining to embryonic tissues. The

development of the gonads and the metamorphosis of the Wolffian and Müllerian ducts into the secondary internal reproductive organs was rapidly worked out in animals of every vertebrate order, by an army of investigators too numerous to mention in a short resumé. The story of the first appearance of primordial germ cells and their migration through the tissues of the embryo to the newly forming gonads, adumbrated in the 1880's by the work of Semon, was confirmed and extended to several species of mammals. If in these latter creatures and in the human species, the complete line of descent from the fertilized ovum to the first appearance of the germ cells is still not as clear as in many lower forms, enough at least was discovered within a few decades to indicate an essential similarity in the history of the germ cells in all vertebrates.

To the embryologists of Europe and America we owe in large part also the successful analysis of the mammalian reproductive cycle that has been achieved during this half century. In order to procure mammalian embryos of known age the time of ovulation and fertilization had to be related to the outward manifestations of the estrous cycle. Comparative description of the cycles of the various mammals for this purpose was climaxed by the discovery, or rather rediscovery and practical application of cyclic changes in the vaginal epithelium by C. R. Stockard and G. N. Papanicolaou. The vaginal smear method, thus introduced to the experimental laboratories, made possible a wide range of investigations on the physiology and biochemistry of the cycle and the ovarian hormones. As applied to the white rat by Herbert M. Evans and J. A. Long it became a basic tool in such studies.

Another influence which also greatly forwarded investigation of the ovarian cycle has already been mentioned. This was the effort of the gynecologists and especially gynecologic pathologists to interpret cyclic events in the human ovary and uterus. One of the most notable American discoveries, that of the influence of the corpus luteum in decidua formation by Leo Loeb, stemmed from his familiarity with the German studies on the human cycle. Much of our knowledge

of the corpus luteum and its hormone, progesterone, was in fact won by investigators who approached the problem through gynecology.

Had it not been for the first World War, moreover, European gynecologic experimenters might have attained clear knowledge of the estrogenic hormones, for even before 1900 Emil Knauer and Josef Hallban of Vienna had demonstrated in a preliminary way the endocrine dominance of the ovaries over the uterus, and by 1913 various investigators, notably Henri Iscovesco of Paris and Otfried Fellner of Vienna, had prepared crude extracts which we now know contained estrogens. It remained, however, for the American zoologist-anatomist Edgar Allen and his biochemical colleague E. A. Doisy, equipped with the vaginal smear method of testing ovarian hormone action, to isolate an estrogen from the fluid of the Graafian follicles, thus starting an era of ovarian endocrinology which has ultimately resulted in clear definition and discrimination of estrogens and progestins and their respective effects upon the uterus and other organs of the reproductive system. Applying this new knowledge to the complexities of the human reproductive cycle, the zoologists, embryologists, gynecologists and endocrinologists, among them several distinguished contributors to the first edition of this work, have combined forces to work out a clear account of the endocrine basis of menstruation and the implantation of the primate embryo.

The parallel story of the hormones of the testis can be read in the successive editions of *Sex and Internal Secretions*. Berthold's proof, published in 1849, that in fowls the testis presides over the development of the cock's comb, wattles, and spurs ultimately led to the isolation of the first known androgen in F. C. Koch's laboratory at Chicago, and thence to the development of a great body of knowledge about androgenic steroids.

The more complex history of the hormones of the hypophysis, becoming somewhat clearer in each successive edition of this work, well illustrates a main theme of this introductory essay, namely the dependence of scientific advance upon the

intermingling of ideas from various fields. It is not merely by chance that among the American workers on the hypophysis two names stand out, those of a surgeon, Harvey Cushing, and a zoologist-anatomist, Philip E. Smith.

The central achievement of this half century of intensive work can be summarized in one sentence. It was, first, recognition, description and explication of the reproductive cycle of mammals and man; and, second, identification of the chemical substances that serve to integrate the cycle and preside over gestation. Those who took part in these investigations recognized, of course, that in due time their work must be extended in two directions, downward to the domain of molecular chemistry and ultimately of ionic physics in order to understand the basic nature of hormone action, and upward to the field of animal and human behavior, where sex gland hormones join with other forms of bodily and mental integration in directing the life and behavior of the organism.

Once the histologists and embryologists had identified the sex gland hormones it was inevitable that further investigation of these remarkable substances should be taken over by biochemists, as can be seen from the successive editions of this book. The chief unsolved problems now demanding attention relate largely to the sites of action of the hormones and the precise molecular effects which they exert upon their target organs. Recent indications that estrogens take part in hydrogen transfer in the citric phase of carbohydrate metabolism, and that progesterone affects uterine muscle cells by altering their permeability to potassium ions, show clearly that there is hope of understanding the action at molecular level of these remarkably specific and powerful substances, which were barely beginning to be known when the first edition of this book appeared in 1932.

As the investigators of the future learn exactly where the sex gland hormones exert their chemical action, and just what they do to the fundamental elements of the cells of their target organs, we may confidently expect ever-increasing knowledge even of the most complex sexual and reproductive activities. Running over the chapter

headings of this third edition of *Sex and Internal Secretions*, we see indeed that almost every author concerns himself with one or another aspect of sex and reproduction in the light of what is already known about endocrine regulation. Chapter after chapter deals with cyclic events determined by sex gland hormones. Phenomena which in the first edition could be explained only suppositionally on a hormonal basis, for example the "free martin" state in domestic cattle, and menstruation in primates, are now much better understood. Others which seemed hardly within the scope of endocrinology are now seen to be in some degree influenced by hormone action, and thus to call for discrimination between endocrine effects and other types of regulation such as gene action and control through the nervous system. The experimental embryologists, for example, seek to understand the respective effects of genes and hormones in determining the development of the internal accessory sex organs; students of animal psychology likewise are beginning to discriminate between the action of hormones and neuro-psychologic factors in determining the patterns of sex behavior.

Among the subjects discussed in this book, only psychiatry and anthropology are as yet not greatly influenced by our recently acquired stores of endocrinologic information. The complex, high-level patterns of human thought and behavior with which these sciences deal are presumably far less subject to chemical regulation than to the integrative control of the nervous system as it affects learning, memory, and racial tradition. Yet when we consider the extent to which daily life and ethnic customs are bound up with the sexual and reproductive activities of mankind, we are prepared to find this edition of *Sex and Internal Secretions* not only advancing greatly beyond its predecessors in the study of animal behavior, but also looking forward, through exploratory chapters on psychiatric and anthropologic aspects of human sex behavior, to a time when we shall more fully understand the interrelations of all the controlling factors even of these most complex activities, upon which the continuation and renewal of life depend.



# EDGAR ALLEN

1892-1913

Soon after his untimely death, February 3, 1943, many of the important details of Edgar Allen's life were recorded by colleagues who were close to him. Separated from these memorials, however, was *Sex and Internal Secretions*, understandably the most permanent and tangible memorial. It is appropriate, therefore, that in this long-delayed third edition, much of the material in those records of his life should be combined with the review of the field in which his substantive contributions and directive thought were so important. With the permission of Doctors George W. Corner and William U. Gardner, portions of their biographical sketches have been used here. A few minor errors have been corrected and supplementary information has been added when it was felt that the picture of Edgar Allen would thereby be enlarged and sharpened. For much of the latter, indebtedness is expressed to Doctor Charles H. Danforth, a long-time friend and senior colleague at Washington University, and to Doctor J. Walter Wilson, with Allen as a graduate student at Brown University.

Doctor Allen ("Ed") to his many friends, and "The Skipper" in his department at Yale) was born at Canyon City, Colorado, May 2, 1892. He was the son of a physician about whom little seems to be known. The Allen family moved to Providence when he was very young. His early training was obtained in the public schools of Providence and at Brown University. Immediately after his graduation in 1915 he started graduate study in biology. This was interrupted two years later by World War I, but was sufficient to fulfill the not too rigorous requirements for a master of arts degree. His record during this period does not seem to have been impressive and nothing that has been learned about it foreshadowed his later distinguished accomplishments. However, one hitherto unrecorded experience,

mentioned on one occasion to the present biographer, may have had unusual significance in the years that followed. Doctor Albert Davis Mead, to whom editions 1 and 2 were inscribed, was Professor of Biology and instructor in the course in vertebrate embryology. At that time and for many years later the uteri, tubes, and ovaries of pregnant sows were collected from the local slaughterhouse and dissected by the class. Allen, probably as an assistant in the course, visited the slaughterhouse where his attention was attracted by the numerous large follicles in most of the ovaries. The curiosity thus engendered seems to have been the extent of his interest in reproductive physiology while he was at Brown, but it could have been instrumental in directing his attention to the ovary a few years later in St. Louis, and it could have prepared him to seek the sow's ovaries as a source of follicular fluid when he was desirous of obtaining large quantities of it for his first tests on spayed mice.

In May, 1917, he volunteered for service in the Brown University Ambulance Unit. Later he transferred to a mobile unit of the Sanitary Corps with which he served in France. When he was discharged in February, 1919, he held a commission as second lieutenant.

Before leaving for France in 1918 he married Marian Pfeiffer, a fellow student enrolled in Pembroke College, the Women's College in Brown University. Throughout the balance of his life she was his devoted companion. She too died as a relatively young woman and did not long survive him. There are two daughters. For a man in his position, he lived modestly. It is easy to imagine that he valued the warmth and affection of his family and friends and his boat above other luxuries he might have had.

When he returned to civilian life he had

no permanent position in sight, but he must have sought the help of Mead, for during the summer of 1919 he was an investigator in the laboratory of the U. S. Fish Commission at Woods Hole. Doctor H. C. Bumpus, an older colleague of Mead's, had been Director of the Biological Laboratory in the Fish Commission at Woods Hole and summer appointments, paying two or three hundred dollars, were a source of help to the graduate students at Brown in that period. The summer seems to have been important, not because of any research Allen did, but because it was then that Charles Danforth, who was at Cold Spring Harbor for the summer and had heard Doctor H. E. Walter speak highly of Allen, wrote him and called his attention to the instructorship then open in Washington University School of Medicine. Danforth suggested that Allen communicate with Doctor Robert J. Terry, head of anatomy in that institution. He must have done so promptly and been accepted, with the understanding that graduate study would be continued. Danforth's recollection of his first sight of Allen is repeated:

"When I returned to St. Louis in the fall and went up to the anatomy department I saw a man in the hall whose white hair and impressive bearing led me to suspect that he was probably a distinguished alumnus returning for a visit. I soon learned, however, that this was Mr. Allen, who had been appointed instructor in anatomy and was already installed in an office on the third floor."

Little time seems to have been lost in starting his work for the Ph.D., although the circumstances under which the choice of a problem was made are somewhat obscure. Doctor B. H. Willier who met Allen for the first time that summer (probably on "stony beach") does not remember that he mentioned any special interest in the physiology of sex and reproduction. Danforth, who saw much of him from this time on, believes that two circumstances may have been important. His office was on the floor with that of Doctor Leo Loeb, always a stimulating person, and in the

animal quarters above was a colony of mice which had been developed for use in what was perhaps the first course in embryology to be based exclusively on mammalian material—gametogenesis, follicular growth, ovulation, fertilization, cleavage, etc. He probably discussed problems with Loeb and he must have read the recent paper of Stockard and Papanicolaou in which changes in the vaginal epithelium in the guinea pig were correlated with the ovarian cycle. Whether he was sensitive to the generally increasing interest in reproductive phenomena or was influenced more by the fact that the mouse had been inadequately studied and was right at hand and ready is not known. The latter possibility would have been consistent with his temperament and the way he worked. On the other hand, the fact that the first of the three "purposes" stated in his thesis was "to make possible a more efficient mating for the collection of embryological material" may indicate that the larger importance of what he was about to start was not yet apparent to him.

With the double responsibility of teaching and doing the research for a thesis, he must have worked incredibly long hours. But the rewards were great. The observations recorded in his thesis, "The oestrous cycle in the mouse," ignited the fire that was to burn and to be spread during the remaining years of his life, and to eradicate forever the diffidence which characterized him during his earlier graduate years at Brown. Briefly, he observed that large follicles were present in the proestrous and estrous stages of the cycle, but that ovulation had occurred by the time of the metestrus. Regressive changes were noted in the uterus and these were analogized with menstruation in lower primates and the human female. The reference on page 111 to Robinson's belief that a secretion from the follicle causes estrous changes reveals how close he was to the hypothesis that was to receive general acceptance only a few years later. It is clear, however, that he was not ready for this simple and direct conclusion. Instead, he started by rejecting the suggestion that the growth stimulus

to the genital tract comes from the corpus luteum and then, after noting that "the follicles are the only remaining ovarian possibility," continued, "the presence of maturing ova in large follicles is the cause of the prooestrus and oestrus" and "the renewal of the ova at ovulation (or their atresia if this fails to occur) is the primary cause of the degenerative changes of the metoestrus."

Except for the addition of the active role of the estrogenic substances contained in the follicular fluid, demonstrated by himself and Edward A. Doisy less than two years later, the pattern of Allen's thought for the next 20 years was contained in his thesis--the cyclic origin of ova from the germinal epithelium, the primacy of the ovum, the growth effects of estrogens, the consequences of their withdrawal, a discounting (the word used in his thesis) of the importance of the hormone of the corpus luteum in the regulation of reproductive phenomena.

Rarely has so much of the important conceptualization of a pre-eminent scientist been "roughed in" in his thesis. Also of interest is the place of the thesis in the history of American anatomy. It was written at a time when the emphasis was shifting from structural anatomy to functional anatomy. Rightly or wrongly, there were then, as there are now, those who feel that this trend could go too far. Allen seems to have been caught in this controversy. At all events, he must have felt compelled to enlist the help of friends at Brown, for it was the men there with their orientation toward biology who seem to have been less concerned with the amenities of the time and to have recommended that he be awarded the Ph.D. The omission of any acknowledgment to individuals or to institutions could have been an understandable oversight in his haste to test the action of follicular fluid on the vaginal epithelium of the mouse, or it could have been a device for avoiding any embarrassment. It is a coincidence that 15 years later in an office at Brown when a younger colleague was threatening to look into the problem of the hormonal control of mating behavior, Allen

asked in his characteristically friendly way and also somewhat paternally, "... why don't you return to your work on the epididymis?"

With hurdles of the thesis and its publication behind him, and the conviction that the follicular fluid contains the substance he was seeking, he must have thought of injecting follicular fluid from the large follicles of the sow (he had seen them at Brown) into ovariectomized mice and examining the vaginas for the sequence of changes he had described in intact mice. It is clear that the idea was not suggested to him by anything he read. As he often said jocularly, we did the work first and looked up the literature later. The published statement to this effect (*J. Biol. Chem.*, **61**: 711-727, 1924) was somewhat qualified but almost as direct, "... we paid but little attention to the papers of the various workers who have claimed to have demonstrated active preparations until after our own first definitely positive results were obtained." An unconventional approach, but excusable perhaps when the hunch is as "logical" as it was to Allen.

By the early spring of 1923 he had made promising preliminary tests and a few days before Charles Danforth left Palo Alto for the Anatomists' meetings in Chicago, he received an exultant telegram saying that he (Allen) had succeeded in inducing estrus in a spayed mouse by injecting follicular fluid. Others had come close to the discovery, but the reason they failed was that no one had had a clear-cut practical test. Danforth is the authority for saying that the ideas back of all this were Allen's, but in order to obtain a purified product of the active hormone in the liquor folliculi he was using, he enlisted the cooperation of Edward A. Doisy whose laboratory was in an adjoining building. Time has made it clear that Doisy was undoubtedly the most capable collaborator Allen could have found anywhere for this kind of research.

A side of Allen that ingratiated him to all was seen at the time of the first announcement of the discovery of the action of follicular fluid on the vagina and is quoted

from Danforth's letter to the present biographer:

"On my way to the 1923 meeting of Anatomists I went around by St. Louis and had dinner that night at the Allen home. In the evening Doisy, Allen, and I had a long and animated discussion over how their findings should be reported. Allen, sanguine and ebullient, was all for announcing them immediately at the Anatomists' meeting, even though there was no place for such an announcement on the program. Doisy, no less convinced of the importance of the findings, so far as they went, but temperamentally careful and thorough, thought any announcement should be withheld till more extensive data could be presented. Allen did not weaken, and when he was called upon at the meetings to present his paper, "Ovogenesis during sexual maturity," which had been duly submitted and published in the abstracts, he by-passed that paper with only a few remarks and used the available time to tell about the effects of follicular hormone on spayed mice. I think this oral report was the first public announcement, the first published one being the Allen-Doisy paper in the *Journal of the American Medical Association*, September, 1923."

Danforth's letter continues:

"When the report was presented, I think it was received on the whole with reservation if not outright skepticism, particularly since no abstract had been published and the topic was unannounced and unexpected. George Corner said later that was true in his case. Someone else who was there told me of his own skepticism and said that he thought Allen, relatively unknown and with an unconventional idea, was regarded as something of an 'upstart.' Stockard is said to have made some very caustic comments, which I don't recall. Herbert M. Evans seems to have been among the few who immediately sensed the significance of the paper. He and I returned to California on the same train and over and over he kept saying, 'I

think Edgar (he sometimes called him Ezra) Allen *has* something,' or words to that effect."

Cooperation with Doisy continued in a skillful chemical analysis which soon made possible the isolation and chemical identification of the estrogenic hormones. It is unlikely that this stage of the investigation would have been greatly prolonged had Allen adhered to a 9 to 5 o'clock schedule or a 40-hour week, but it is apparent from a letter he wrote to Doctor Carl G. Hartman that the discovery of the Allen-Doisy test for estrogens might have been delayed had he not made a midnight trip to the laboratory. According to Hartman, "It was Saturday night and Ed and his wife had been at the theatre. Would he or would he not make a midnight visit to the animal colony at the University in St. Louis and examine the castrated mice which had been receiving Doisy's extracts? He did and much to his delight found cornified cells in the vaginal smears, which might not have been there if he had waited till Monday morning!"

Beyond this point, most of what happened has been recorded by the earlier biographers. In 1923, and almost certainly before the importance of his work was fully appreciated, Allen was appointed Chairman of the Department of Anatomy in the then 2-year University of Missouri School of Medicine. He was made Associate Dean of the School of Medicine in 1929 and Dean the following year. He was happy at Columbia, "things have worked out so nicely here. . .," he wrote Danforth, and later he began to think he "was planted definitely in Missouri." But April 1, 1933, he wrote, "Dean Winternitz visited Columbia day before yesterday and asked me to go on to Yale . . ." as Professor of Anatomy and Chairman of the Department of Anatomy in the Yale University School of Medicine.

The unusual extent to which his research and the research he supervised in his department were suggested by his thesis has been indicated. We find, therefore, investigations pertaining to the problem of ovogenesis. At a time when it was generally assumed that the female mammal possesses a full

quota of ova when she is born, he demonstrated that new ova arise after birth and even after sexual maturity.

As Doctor William U. Gardner, a former student and his successor at Yale, has written, his early conviction that the ovum is "the dynamic center of the follicle" persisted throughout his life; he left two partially completed manuscripts dealing in part with the subject. Less than a year before he died he wrote to Danforth, "I still think of the ovum as a dynamic center for mitosis and there is no reason why the fertilized ovum shouldn't be." Gardner is of the opinion that Allen's interest in ova prompted the collaboration with Doctors J. P. Pratt, Q. J. Newell and L. J. Bland that resulted in securing in 1930 the first human ova from the oviduct, and in providing evidence bearing on the time of ovulation in the human female.

Overshadowing these studies of the ova were, of course, Allen's many investigations on the relationship of the ovarian estrogenic hormones to the growth of tissues. His demonstration that removal of the ovaries of the rhesus monkey under appropriate circumstances is followed by a uterine bleeding, indistinguishable from that of normal menstruation, led to the formulation of his estrogen-deprivation theory of menstruation. Although challenged and shown to be in need of modification, his statement of this theory stimulated many studies of that phenomenon which is still not understood.

After moving to Yale, he became increasingly involved in investigations of the influence of steroid hormones on carcinogenesis, especially the relationship of estrogens to malignant transformation of the uterine cervix. His interest in the growth-stimulating capacity of the ovarian hormones was further indicated by his use of the mitosis-stimulating and mitosis-arresting drug, colchicine, in studies on the genital tissues.

During the relatively short span of his professional life, he and his collaborators published more than 140 original investigations. Of these, most were under joint authorship. This is explained by the fact

that he rarely worked alone on a scientific problem. This may have been just as well, for his excitement and enthusiasm reached their peak in team work. In all such relationships, but especially when younger colleagues were involved, he gave full support and generous credit. He would have been proud of the large number of the latter who have since worked their way to important posts in anatomy. Were he alive, he probably would still be prodding them to look into this or that problem.

Although the number of articles and reviews of which Allen was author or co-author was relatively large, it was small compared with the many which can be attributed to the encouragement and enthusiasm he inspired among his students and associates, and to the many more which his work inspired in other laboratories throughout the world. In this sense, rather than in the strictest sense of the word, he was a foremost anatomist.

At the height of his career, he undertook the editing of the first edition of *Sex and Internal Secretions*. The editorship of the second edition was shared with Doctors Danforth and Doisy. The former was undoubtedly over-modest in recalling the parts of the co-editors in the undertaking, but his statement is quoted for the information it contains.

"I had helped a little with the first edition, especially with Bridges' chapter (Bridges being in Russia at the time), and in the second edition took responsibility for Section A, as Doisy did for his group of chapters. I read the entire book in manuscript or in proof (mostly both) as I think Doisy did also, but neither of us, I feel sure, thought of ourselves as co-editors. On Jan. 4, 1939 Allen wrote, 'I have asked the publishers to make the book, Allen, Danforth and Doisy; as it has been team work all through.' My own reaction, and probably Doisy's is expressed in my reply of January 9, 'Instead of writing a long personal letter in reply to yours of January 4 I am going to send a short note by air mail protesting against your suggestion in the last

paragraph. It would be quite unjust and misleading for you to put Doisy's and my names in any sense coordinate with yours. . . . And to put our names in any but the most subordinate position would be to give credit that is not due.' "

Allen's services were not unrecognized. Three of the universities with which he was associated, Yale, Brown, and Washington University, awarded him honorary degrees. Had he lived a few months longer, he would have received an honorary doctor of law from the University of Missouri. In 1937 he was awarded the Legion of Honor in Paris where he was guest of the Fondation Singer-Polignac at a colloquium on the sexual hormones. In 1941 he was honored by the Royal College of Physicians of London when they conferred upon him the Baly Medal for researches on the female sex hormones. In the last year of his life he was president of the two national societies most closely representative of his field of work, the Association for the Study of Internal Secretions (now the Endocrine Society) and the American Association of Anatomists.

As Corner, Danforth and Stone wrote in their memorial for the American Association of Anatomists, "Allen was a striking figure personally, for his broad shoulders, ruddy face and snow-white hair made him conspicuous in any group. He made friends quickly and was always the first to encourage and to admire good work by others. His boyish frankness and his good will contributed more perhaps than any other factor to the effective cordiality which has prevailed among the American workers in the physiology of reproduction." The writer of this sketch recalls that in any meeting Allen was always one of the first to rise to the floor with a question or to make a constructive comment.

The best of the spirit of the man that we can preserve is contained in the form of his own words, written informally to his friend, Charles Danforth, with whom he corresponded so frequently and voluminously. A number have been selected for the side of him they will recall, the enthusiasm and

imagination that enabled him to do the amount and quality of work he did.

November 6, 1935: "We just had a keen thing happen here. Dr. George M. Smith returned from Europe with information about a drug which prevents mitotic figures from completing division. . . . Combining this with theelin stimulation. . . ." May 23, year not stated: "Have been working since early morning on the slides from the monkey experiments. They are a corking good lot of evidence and I am in one of those elated, trembly, inspired sort of heavens to which new ideas always bring a fellow. If you were in reach, you would have been dragged over precipitately to my scope, or interrupted to talk things over a dozen times. . . . As it is, I must run my ideas through a slow movie instead of talking you to death. . . . Growth in the vaginal wall is almost unbelievable. Growth in the cervical glands is more so. They grow so darned much that the cervix looks like a tumor and the cervical canal becomes a tortuous thing like the lower Mississippi." A lot of histological detail, then: "the tubes are a knockout . . . this would seem to make ciliation a growth phase of the nonciliated cells and full ciliation dependent on presence of the hormone. The mammary gland whole mounts are wonders. I am so elated as to be almost damned crazy. Am sure I'd crack one of your ribs if I could get at you." Then, "Yesterday a letter from the National Research Council giving me \$800 more for monkeys. . . . Ain't it just too lucky to believe. . . ." And finally, in closing one of his letters: "Well you darned fool, Allen, it will take him 10 minutes to read your letter now, aren't you ever going to stop writing?"

About 10 years before Allen died he suffered a severe coronary attack, while waiting for a train in the Jacksonville, Florida, Union Station. He loved swimming as well as sailing and, after a strenuous and fatiguing visit with Doctor Robert M. Yerkes

in the heat at Orange Park, had taken time for a long swim in the breakers at Jacksonville Beach. Miraculously he reached New Haven and recovered sufficiently to return to his work. Nothing would have kept him from it. When war was declared in 1941 he was tired, but he insisted on joining the Coast Guard Auxilliary for a weekly tour of duty on Long Island Sound, as opera-

tions officer of a flotilla. It was during one of their patrols that he died of coronary occlusion. There was much that was fitting to such an end of his active life. No tribute could have been more appropriate than that phrased by Gardner in the Edgar Allen Memorial Number of the Yale Journal of Biology and Medicine, "The 'Skipper' left with 'all sails filled.'"







## PREFACE TO THE THIRD EDITION

The impact of the first two editions of *Sex and Internal Secretions* can never be measured, but it must be near the front for books of its kind. Few books seem to have served their purpose better and few, 20 to 25 years after their appearance, seem to be valued as greatly by those who are fortunate to possess copies. It was to be expected, therefore, that pressure would be brought to bear for the preparation of a third edition. Whether the Publisher's attempts to find an editor miscarried because of the character of the new order ushered in by World War II, or because discretion was considered the better part of valor may never be known. The odds favored the latter explanation because there was no direction in which a successor to Edgar Allen, Edward A. Doisy and Charles H. Danforth could go except down. Nevertheless, there were reasons for accepting the challenge and attempting to do for the present generation of reproductive physiologists what Allen, Danforth and Doisy and their many colleagues did for theirs. Most of the problems to which they addressed themselves had not been solved, although the need for answers was as urgent as ever, and perhaps more so. The definition of these problems had become obscured, partly by the addition of many contradictory and confusing data to the literature relating to them, and partly by the rising tide of interest in other glands of internal secretion, notably the thyroid and adrenal. Finally, new technologies had pervaded the field and there were many new data and concepts to be evaluated and woven into the fabric Allen and his contemporaries had created.

In the preparation of the third edition little of the first two editions was to be retained except the title, *Sex and Internal Secretions*, and the ideals by which the authors of these editions must have been guided. Within a framework of careful scholarship, these were seen to be a resumé of the solid facts that had been learned from

test and retest, broadly critical discussions, enumeration of the important unsolved problems, and the preparation of lists of references complete enough for the guidance of any seeker of information, whether his interest was in the extension of basic studies or the application to clinical and agricultural problems. Adherence to these ideals has not been easy. Even if ample allowance is made for editorial ineptitude, the period 1958 to 1961 is different from 1932 and 1939. Reviews and symposia are more numerous and many are in a style that is alien to the traditions of *Sex and Internal Secretions*. There are demands on the time of many of us which, 20 years ago, were reserved for only a few, and the volume of published reports has long since outstripped our capacity properly to encompass them.

Despite the difficulties and misgivings, an effort has been made to step into the void created by the lapse of the old *Sex and Internal Secretions*. Both similarities and differences will be noted. Relatively more space has been given over to the role of the gonadal hormones in the control of reproductive behavior, and relatively less to the biochemical problems of hormone synthesis, utilization, and metabolism. This "slighting" of the biochemical side, if it is to be so considered, does not reflect any lack of appreciation of the key position occupied by this discipline. It is explained, rather, by the opinion of the biochemists who were consulted that another review, just at this time, would be anticlimactic to a number of the excellent reviews which have recently been published. The chapter by Dr. Villee, therefore, is, in his words, a presentation of the general picture without being an exhaustive citation of the tremendous body of relevant literature.

The suggestion made above that some of the shortcomings in this third edition are a reflection of changes in our habits of working is not to be taken as an attempt to

excuse any errors that properly belong on the editor's doorstep. He has learned as he has gone along, but finds himself reacting very much as he usually does at the end of a lecture if it were to be given again, parts of it would be done differently. To the contributors, there is a feeling of the deepest gratitude for the time and thought they have given to the preparation of their chapters. The editor is indebted, too, to the National Institute of Mental Health, National Institutes of Health, for a research grant, M-4648, which has taken care of a number of the costs of publication. Justification for this action is believed to have been

given by the expansion of the section on the gonadal regulation of reproductive behavior. This development, in turn, would have pleased Robert M. Yerkes. He was sensitive to the need for truly scientific studies of sexual behavior, the mechanisms which participate in its expression, in the determination of its character, in its regulation, and in its development. But he was equally aware of the importance of investigations that are purely physiologic, biochemical, and morphologic, and in a quiet but effective way did much to encourage many that are recorded in the first two as well as in the present edition of this book.

## PREFACE TO FIRST EDITION

It is the purpose of this book to survey the most important recent researches in problems of sex, especially those concerned with internal secretions, in order that concepts already established by experimental evidence may be clearly stated and made readily available. While general principles can in many cases be stated concisely, the recent data have accumulated so rapidly that there has not yet been time for retesting and evaluating much of the evidence. This may account in some chapters for emphasis upon certain work with which contributors may have had personal contacts. Furthermore, sex and reproduction show such wide ranges of variation in both the structures and functions involved that major differences, even among species of higher mammals, make generalizations both difficult and dangerous. This whole field has recently undergone such rapid growth that many new questions have arisen to challenge the investigator's curiosity. An attempt will be made to indicate productive approaches to some of these unsolved or only partially solved problems.

This book is intended for the reader with a moderate biological background, to whom the less involved technical terminology may not prove a serious handicap. It is not our intent that it should be a "popular book on sex." Instead, it is designed for those interested in the progress of research in problems of sex, and those who may be already engaged in investigations thereon or casting about for promising problems for investigation. Physicians who are interested in fundamentals will find much valuable recent material. In supplying a biological foundation for education in matters of sex, it should also attract the interest of serious students of sex function in man.

Specialization in research has reached the point where any detailed authoritative survey requires a group effort. Consequently, the editor attempted to gather together a group of investigators whose work has established them in their respective fields.

Each contributor has developed his chapter in his own way and assumes full responsibility for the content of his section, including his discussion of the work of other investigators.

Since it was inevitable that considerable correspondence would be involved, introducing the time-transport factor, choice of the group was restricted to American investigators. Several prominent workers in this field, whom we would have desired as co-authors, have necessarily been omitted because of absence abroad or press of other work.

As the Foreword indicates, this project saw its inception in a proposal by Dr. E. V. Cowdry, then Chairman of the Medical Division of the National Research Council, to the Committee for Research in the Problems of Sex. In the publication of many of the contributors to this book, acknowledgment will be found to this Committee for support of investigations. In a sense the book will serve as a summary of some of the work accomplished under grants from this Committee. Obviously, however, it was not desirable to limit choice of contributors to investigators who had received grants from the Committee, and that consideration has not determined their choice. Instead, it is probable that the Committee in the first place chose to make grants to these men because of the promise of their work shown by their previous investigations.

The editor wishes to acknowledge the support of the Committee for Research in Problems of Sex, which has made provision for the editorial expenses involved in the preparation of the manuscript. He also wishes to commend the cooperation between investigators who, even though they may be competitors in the same field, have collaborated so well. The cooperation has been completely free from the secretive reserve sometimes encountered among investigators who may be leaders in their particular fields. The editor wishes further to acknowl-

edge the assistance and friendly interest of Dr. E. V. Cowdry, not only during the initial phases of this project, but throughout its progress and consummation. Dr. F. R. Lillie has counselled wisely in regard to titles and content of some of the sections. Valuable counsel and encouragement has also been received from several of the contributors. The editor also wishes to commend

the contributors for their team-work in eliminating or reducing overlaps between sections which is so necessary in the unification of interlocking material from closely related subjects.

EDGAR ALLEN

*University of Missouri School of Medicine  
Columbia, Missouri  
May, 1932.*

SECTION A

---

*Biologic Basis of Sex*



# 1

## GENETIC AND CYTOLOGIC FOUNDATIONS FOR SEX

*John W. Gowen, Ph.D.*

DEPARTMENT OF GENETICS, IOWA STATE UNIVERSITY, AMES, IOWA

I. BASIC LITERATURE . . . . .	3	B. Sex in the Mouse . . . . .	50
II. MECHANISTIC INTERPRETATIONS OF SEX	4	C. Sex and Sterility in the Cat . . . . .	50
A. Concept of Sex Determination . . . . .	5	D. Deviate Sex Types in Cattle and Swine . . . . .	51
B. Sex as Associated with Visible Chromosomal Differences . . . . .	6	E. Sex in Man: Chromosomal Basis . . . . .	52
C. Changing Methods of Cytogenetics . . . . .	7	1. Nuclear chromatin, sex chromatin . . . . .	55
D. Chromosomal Association with Sex . . . . .	8	2. Chromosome complement and phenotype in man . . . . .	56
E. Balance of Male- and Female-Determining Elements in Sex Determination . . . . .	8	3. Testicular feminization . . . . .	56
III. SEX GENES IN <i>DROSOPHILA</i> . . . . .	13	4. Superfemale . . . . .	57
A. Mutant Types . . . . .	13	5. Klinefelter syndrome . . . . .	58
B. Major Sex Genes . . . . .	14	6. Turner syndrome . . . . .	59
C. Other Chromosome Group Associations: <i>Drosophila americana</i> . . . . .	16	7. Hermaphrodites . . . . .	59
D. Location of Sex-determining Genes . . . . .	17	8. XXXY + 44 autosome type . . . . .	61
IV. SEX UNDER SPECIAL CONDITIONS . . . . .	20	9. XXY + 66 autosome type . . . . .	63
A. Species Hybridity . . . . .	20	10. Summary of types . . . . .	63
B. Mosaics for Sex . . . . .	21	11. Types unrelated to sex . . . . .	63
C. Parthenogenesis in <i>Drosophila</i> . . . . .	22	F. Sex Ratio in Man . . . . .	65
D. Sex Influence of the Y Chromosome . . . . .	23	XI. REFERENCES . . . . .	66
E. Maternal Influences on Sex Ratio . . . . .	25		
F. Male-influenced Type of Female Sex Ratio . . . . .	26		
G. High Male Sex Ratio of Genetic Origin . . . . .	27		
H. Female-Male Sex Ratio Interactions . . . . .	28		
V. SEX DETERMINATION IN OTHER INSECTS . . . . .	29		
A. <i>Sciara</i> . . . . .	29		
B. <i>Apis</i> and <i>Habrobracon</i> . . . . .	32		
C. <i>Bombyx</i> . . . . .	34		
VI. SEX DETERMINATION IN DIOECIOUS PLANTS . . . . .	35		
A. <i>Melandrium</i> . . . . .	35		
B. <i>Rumex</i> . . . . .	40		
C. <i>Spinacia</i> . . . . .	42		
D. <i>Asparagus</i> . . . . .	43		
E. <i>Humulus</i> . . . . .	43		
VII. MATING TYPES . . . . .	43		
VIII. ENVIRONMENTAL MODIFICATIONS OF SEX . . . . .	44		
A. Amphibia . . . . .	44		
B. Fish . . . . .	45		
IX. SEX AND PARTHENOGENESIS IN BIRDS . . . . .	47		
X. SEX DETERMINATION IN MAMMALS . . . . .	49		
A. Goat Hermaphrodites . . . . .	49		

### I. Basic Literature

In the first edition of *Sex and Internal Secretions* published in 1932, Bridges discussed the closely prescribed problem of the genetics of sex, particularly as it was related to one species, *Drosophila melanogaster*. The treatment was sharply focused on the advances made, chiefly through his own researches, in understanding the functions of the genetic and cytologic factors operating during embryologic development which ultimately establish the sex types. The emphasis was on gene action through interchromosomal balances as they may affect sex expression. The second edition of 1939 brought this material up-to-date and, at the same time, offered a much broader treatment by the inclusion of accumulated evidence on how differentiation for sex comes about in other forms. There is no substitute for a careful reading of these two presenta-

tions as background material for a present day understanding of sex determination. The current presentation makes no attempt, except in the barest outline, to repeat this early material other than in those aspects which bear on the advances that have been made since the printing of the second edition.

Immediately following the publication of the first edition of *Sex and Internal Secretions* there was a resurgence of interest in the problems considered in that book. The resulting research led to notable advances in available knowledge. Seven years later the second edition was published. A second wave of accomplished research appeared. In the interim of the past 21 years extensive advances have been recorded, particularly in understanding the mechanisms of sex differentiation in plants as well as in many animals. Among others, the data on *Melandrium*, *Asparagus*, *Rumex*, and *Spinaea* have been of first importance. Further information on *Drosophila*, *Habrobracon*, and *Xiphophorus* has notably broadened our viewpoints. Beginnings have been made to a better understanding of the conditions for sex separation in bacteria, protozoa, bees, birds, goats, mice, and man. To these specific contributions may be added the basic advances in understanding the methods by which genes are transmitted from one generation to the next, accomplish their actions in development, and by which chromosomes reorganize and reconstruct gene groups.

The period has also been one of excellent monographic treatments on different phases of the subject. Wilson's *The Cell in Development and Inheritance* (1928) and earlier, Morgan's *Heredity in Sex* (1914), Schrader's *The Sex Chromosomes* (1928) and Goldschmidt's *Lymantria* (1934) retain their pre-eminence. To this list have now been added the publication of extensive tabulations of chromosomes of cultivated plants by Darlington and Janaki Ammal (1945), of animal chromosomes by Makino (1951), and the yearly index to plant chromosomes beginning with 1956, compiled by a world-wide editorial group and published by the University of North Carolina Press, Chapel Hill, North Carolina. These volumes give access to the basic chromosomal consti-

tutions and their sex relations for far more species than were heretofore available. Inheritance information has been made more accessible and at the same time in more detail. The tabulations of mutants observed in particular species as in *D. melanogaster* (Morgan, Bridges, and Sturtevant, 1925; Bridges and Brehme, 1944) have been followed by those of corn, mouse, domestic fowl, rat, rabbit, guinea pig, *Habrobracon*, and many other animal forms, together with similar tabulations for cereals and a number of other plant species. Books of particular interest include those of Hartmann, *Die Sexualität* (1956), White, *Animal Cytology and Evolution* (1954), Goldschmidt, *Theoretical Genetics* (1955), Hartmann and Bauer, *Allgemeine Biologie* (1953), and Tanaka, *Genetics of Silkworms* (1952), and special reviews in various volumes of *Fortschritte der Zoologie* (1 to 12) (Wiese, 1960). Basic normal development of *Drosophila* has been presented in convenient book form in papers by Cooper, Sonnenblick, Poulson, Bodenstein, Ferris, Miller and Spencer, *Biology of Drosophila* (Demerec Ed., 1950). Special papers having a direct bearing on the subject matter include particularly those of Pipkin (1940-1960) in analyzing the various chromosomes of *Drosophila* for sex loci, of Tanaka (1953) and Yokoyama (1959) for their studies and reviews of the genetics of silkworms, and of Westergaard (1958) on sex determination in dioecious flowering plants.

## II. Mechanistic Interpretations of Sex

The records of search for basic mechanisms involved in the determination of sex have been foremost in the writings of man from the beginning of historical record. These ideas have included all forms of mechanisms both intrinsic and extrinsic to the organism. The most constructive advance, although not realized at the time, came through the recognition of cell structure, chromosome maturation and the discrete behavior of the inheritance. Differences in chromosome behavior were noted but not always related to facts of broader significance. The period was one of expanding observations and development of ideas as they applied to species in general and



also to the further complications which arose with more extended study. These complications included differences not only in one chromosome pair but in several. The significance of a balance between these chromosome types as well as with the environment was grasped by Goldschmidt and particularly by Bridges where his more favorable material brought out sharper contrasts in types and in the chromosome behavior. Ideas related to chromosome balance as they may affect developmental processes were developed. Goldschmidt emphasized that this balance could include factors in the cytoplasm as well as in the chromatin material. Bridges' observations on the other hand, pointed most strongly to the chromatin elements where changes in chromosome numbers were often accompanied by sharp differentiation of new sexual types.

Concepts of sex determination broadened. They came to include all the chromosomes in the haploid set, a genome, as a whole. The important concept of single chromosome difference being all important has been replaced with that of a balance between the chromosomes. It has sometimes been emphasized that it is this balance which is the most significant element in sex determination. Present day research seems to be pointing rather to even finer structures than the chromosomes in that the main search is on for the particular genes within the inheritance complex which contribute the characteristics of sex. Bridges' work has sometimes been asserted as committed to a particular type of balance in the chromosome. However, his writings (1932) make it clear that this balance is, in his judgment, basically due to the genes actually contained within the chromosomes rather than to the chromosomes themselves. This view is further emphasized in the second edition of *Sex and Internal Secretions*. "Sex determination in numerous forms with visible distinctions between the chromosome groups of the two sexes was at first interpreted on a 'quantitative' basis, as due to graded amounts of 'sex-chromatin.' But because even more species were encountered in which no visible chromosome difference was detected, the formula-

tion was changed to include also 'qualitative differences in sex-chromatin.' Now, sex is being reinterpreted in terms of *genes*, with investigation by breeding tests penetrating to detail far beyond the reach of cytological investigation. The chromosomal differences are now treated as rough guides, and chromosomal determination is being resolved into genic determination.... Hence the difference in sex must be put on the same basis as that of any other *organ differentiation* in plant or animal, for example, the difference between legs and wings in birds—both modifications of ancestral limbs."

In contrast to what some have interpreted, Bridges was not committed to a specific chromosome balance, as for instance the X chromosomes to the A chromosomes in *Drosophila*, for all species. Rather he looked on that particular balance as but one mode of gene association in chromosomes that could bring about differences in gene action on development which would lead to sexual differentiation in its various forms. In that sense his ideas prepared him for, and were in conformity with, the types of sex differentiation which later became established in such forms as *Melandrium* and in the silkworm. In his concepts of sex determination and in his active interest in making genetics more specific, there can be little doubt that his theory would include those of the present and would also be welcome as refining and more sharply defining the significance of cytologic and genetic elements important to sex differentiation.

#### A. CONCEPT OF SEX DETERMINATION

As frequently happens, observations are made often before their significance is more than dimly understood. Background information may be insufficient for the facts to become clear. This was true when a lone chromosome was discovered as a part of the maturation complex in sperm formation of *Pyrrhocoris*. The association of the presence of this element with the idea of its being the arbitrator between male and female development in certain species was not made until 10 years later. Henking (1891) observed in *Pyrrhocoris* 11 paired chromo-

some elements and one unpaired element which after spermatocyte divisions led to sperm of two numerically different classes, one carrying 11 chromosomes plus the accessory chromosome and the other carrying only the 11 chromosomes. His observations were confirmed by several other investigators and in principle for other insect species over a decade following. The first suggestion that this chromosome behavior was related to sex differentiation came from McChung's (1902) observations on the "accessory chromosome" of *Niphidium fasciatum*. It is of some interest to examine the steps by which these conclusions were reached.

"The function exercised by the accessory chromosome is that it is the bearer of those qualities which pertain to the male organisms, primary among which is the faculty of producing sex cells that have the form of spermatozoa. I have been led to this belief by the favorable response which the element makes to the theoretical requirements conceivably inherent in any structure which might function as a sex determinant.

"These requirements, I should consider, are that: (a) The element should be chromosomal in character and subject to the laws governing the action of such structures. (b) Since it is to determine whether the germ cells are to grow into the passive, yolk-laden ova or into the minute motile spermatozoa, it should be present in all the forming cells until they are definitely established in the cycle of their development. (c) As the sexes exist normally in about equal proportions, it should be present in half the mature germ cells of the sex that bears it. (d) Such disposition of the element in the two forms of germ cells, paternal and maternal, should be made as to admit of the readiest response to the demands of environment regarding the proportion of the sexes. (e) It should show variations in structure in accordance with the variations of sex potentiality observable in different species. (f) In parthenogenesis its function would be assumed by the elements of a certain polar body. It is conceivable, in this regard, that another form of polar body might function as the non-determinant

bearing germ cell." The important fact established by this reasoning was that a chromosome could be the visual differentiator between the fertilized eggs developing specific adult sexual differences. It was of little consequence perhaps that for sex itself, in this species, the chromosome arrangement was misinterpreted. The validity of the rules was probed through examinations of the cells of many species by many different observers.

#### B. SEX AS ASSOCIATED WITH VISIBLE CHROMOSOMAL DIFFERENCES

Variations in the chromosome complexes contributing to sexual differentiation were soon found. Probably the most frequent type observed in animals and plants was that in which a single accessory chromosome of the male was accompanied by, and paired with, another chromosome either of the same or of a different morphologic type. This other chromosome, as distinguished from the accessory chromosome now generally called the X, was designated the Y chromosome. For different species the Y ranged in size from complete absence, to much smaller, to equal to, to larger than the X. Besides the X and Y chromosomes, the autosomal or A chromosomes, the homomorphic pairs, complete the species chromosome complement. In this terminology

$$\begin{aligned} \text{Sperm (Y + A) + egg (X + A)} \\ = \text{XY + 2A cells} \end{aligned}$$

of male determining type

$$\begin{aligned} \text{Sperm (X + A) + egg (X + A)} \\ = \text{2X + 2A cells} \end{aligned}$$

of female determining type

Variations in numbers and sizes of chromosomal pairs making up the autosomal sets of different species are familiar cytogenetic facts. These variations may extend from one pair to many chromosome pairs depending on the species. Similar variations may occur in chromosomes of either the X or Y types. The X is commonly a single chromosome but may be a compound of as many as 8 chromosomes in *Ascaris incurva* (Goodrich, 1916). The Y may be lacking

entirely in some species or may be reduplicated in others. Males which form two types of sperm are often called heterozygous for sex, although the term digametic may be better, whereas the females are homogametic.

In other species the females show the chromosomal differences whereas the males are uniformly homogametic. These types are principally known in the Lepidoptera, more primitive Trichoptera, Amphibia, some species of Pisces, and Aves. The single accessory chromosome is present in the females whereas the males have two. It may be unpaired or be with another chromosome of different morphology and size. The sex types may be symbolized by designating the accessory chromosome by Z and its mate W as a means of separating possible differences between them and the X and Y chromosomes. The significance of these differences is not clearly established with the consequence that some investigators prefer to substitute the XY designation for the females and the XX condition for the males of these species. The zygotic formulae are:

Sperm ZA + egg ZA = 2Z + 2A male  
 Sperm ZA + egg WA = ZW + 2A female

A third major chromosomal arrangement accompanying sex differentiation came to light as a result of Dzierzon's 1845 discovery of parthenogenesis in bees. Chromosomal and genetic studies have shown both *Apis* and *Habrobracon* of the Hymenoptera to be haploid, N, for each germinal cell in the male complex and diploid, 2N, in the female. N may stand for any number of chromosomes, as 16 for *Apis* or 10 for *Habrobracon*. The same chromosomal pattern characterizes, so far as known, the other genera of Hymenoptera. Haploidy vs. diploidy is viewed as the most obvious feature predicting differentiation toward the given sex type even though, as in *Habrobracon*, there is evidence for a particular chromosome of the N set carrying a locus for sex differentiating genes. The zygotic sex formulations are:

No sperm + egg N = N male  
 Sperm N + egg N = 2N female

In development, as in some other species

of widely diverse origins, chromosome polyploidy may take place causing the soma cells to differ from the germ cells in their chromosome components.

The common phenotype for plants and lower animals has differentiated sex organs which are combined in the same individual. Plant species seldom depend on any but hermaphroditic types for their reproduction. Lewis' (1942) tabulation for British flora had but 8 per cent of all species depend on other than this form of reproduction. Those that had perfected dioecious systems were not all alike in the system adopted, although species with XY + 2A males and XX + 2A females were in high frequency. Dioecious reproduction was rarely the system common to a whole genus. Recent and multiple origins of dioecious types are indicated by the irregular distribution of species with bisexual reproduction within the different genera and families. Methods for preventing inbreeding have taken other channels as self-sterility genes reminiscent of fertility or sex alleles found in the older bacteria and protozoa. Animals of the lower phyla are those which are most frequently hermaphroditic. Within hermaphroditic species chromosomal distinctions are ordinarily absent. The higher forms with sex and chromosome differences, on the other hand, may show reversion to the hermaphroditic condition from the dioecious or bisexual states.

Other less common cytogenetic controls of sex development have become recognized and better understood. Discussion of their gene and chromosomal arrangements will be considered when these cases arise. The above types will be sufficient to furnish a basis for interpreting the newer data.

#### C. CHANGING METHODS OF CYTOGENETICS

The earlier studies of sex determination depended on the natural arrangements of chromosomes found in different species and on occasional chromosomal rearrangements occurring as relatively rare aberrant types. Further development of genetics has increased the tools for these studies. Mutant genes have been shown to control chromosome pairing in segregation (Gowen and Gowen, 1922; Gowen, 1928; Beadle, 1930).

Different drugs such as chloralhydrate and particularly colchicine and various forms of radiant energy have made it possible to create new types by doubling the chromosomes, by chromosome rearrangement and by changing the chromosome number. Better genetic tester stocks of known composition have been organized, which together with a more exact understanding of the inheritance structure of the species have made for more critical studies. Techniques, which have improved chromosome differentiation and structural analysis through better methods, better dyes, tracers to mark chromosome behavior (Taylor, 1957), and the use of hypotonic solutions in the study of cells (Hsu, 1952), have removed doubts that were created by the earlier technical difficulties. Instrumentation has improved for the measurement, physically and chemically, of cell components.

#### D. CHROMOSOMAL ASSOCIATION WITH SEX

The first genetic linkage groups were associated with the sex chromosomes and were soon shown to follow the patterns of the different chromosome sets observed within the different species. In man, hemophilia inheritance was observed to follow that which was presumed for the X chromosome. Barrage in birds and wing-color pattern in Lepidoptera on the other hand were found to follow the chromosomal patterns of their species where the male was ZZ and the female Z or ZW for the sex chromosomes. The utility of these methods was further probed by Bridges' observations that when chromosome behavior in *Drosophila* resulted in sperm or eggs carrying unexpected chromosome combinations there followed equally unexpected phenotypes in the progeny. The characteristics of these unexpected progeny, in turn, followed those expected if genes for them were carried in the sex chromosomes. The use of these linkage groups as tracers, both as they naturally occur and as they may be reorganized through the treatment effects of such agents as radiant energy, open the possibility of assigning sex effects to, not only chromosomes, but also to particular places within the chromosomes.

Both polyploids and aneuploids, as oc-

curing naturally and as marked by tracer genes, give insight into sex differentiation and its dependence on chromosome inheritance behavior. True polyploids in a species are formed as a consequence of multiplying the entire genome. The possible types may have a single set of chromosomes and genes in their nuclei (haploid), 2 sets (diploid), 3 (triploid), 4 (tetraploid), and so on, representing the genomes 1, 2, 3, 4, to whatever level is compatible with life. Multiplying the genomes within the nucleus often increases cell size but seldom gives the organism overtly different sex characteristics.<sup>1</sup> Aneuploids, on the other hand, give quite different results, the result being dependent upon the particular chromosome that may be multiplied. Particular trisomies in maize, wheat, and spinach, for example, are distinguishable by marked differences in phenotypic appearance that is not attributable to cell size but rather to abrupt deviations in particular characteristics. The genes in the particular trisomic set are unbalanced against those of the rest of the diploid sets within the organism. Their phenotypes express these differences.

#### E. BALANCE OF MALE AND FEMALE DETERMINING ELEMENTS IN SEX DETERMINATION

The foundations for the basic theory that sex determination rests on quantitative relationships of two genes or sets of genes localized in separate chromosomes rests largely on the work of Morgan, Bridges and Sturtevant, 1910, with *Drosophila* and the breeding work of Goldschmidt, 1911, with *Lymantria*. The work of Goldschmidt soon gave extensive descriptions of diploid intersexuality in *Lymantria dispar*. The details of this work scarcely need review because they have been repeated several times and have been summarized recently in Goldschmidt's *Theoretical Genetics* (1955). From Goldschmidt's viewpoint, "the basic point was that definite conditions between the sexes, that is, intersexuality, could be produced at will by proper genetic combinations (crosses of subspecies of *L. dispar*)

<sup>1</sup> The notable exception of the Hymenoptera will be discussed later.

without any change in the mechanism of the sex chromosomes, and this in a typical quantitative series from the female through all intergrades to the male, and from the male through all intergrades to the female, with sex reversal in both directions at the end point. The consequence was: (1) the old assumption that each sex contains the potentiality of the other sex was proved to be the result of the presence of both kinds of genetic sex determiners in either sex; (2) the existence of a quantitative relation, later termed 'balance' (though it is actually an imbalance), between the two types of sex determiners decides sexuality, that is femaleness, maleness, or any grade of intersexuality; (3) one of the two types of sex determiners (male ones in female heterogamety, female ones in male heterogamety) is located within the X-chromosomes, the other one, outside of them; (4) as a consequence of this, the same determiners of one sex are faced by either one or two portions of those of the other sex in the X-chromosomes; (5) the balance system works so that two doses in the X-chromosomes are epistatic to the determiners outside the X, but one dose is hypostatic; (6) intermediate dosage (or potency) conditions in favor of one or the other of the two sets of determiners result, according to their amount, in females, males, intersexes, or sex-reversal individuals in either direction; (7) the action of these determiners in the two sexes can be understood in terms of the kinetics of the reactions controlled by the sex determiners, namely, by the attainment of a threshold of final determination by one or the other chain of reaction in early development; while in intersexuality the primary determination, owing to the 1X-2X mechanism, is overtaken sooner or later—meaning in higher or lower intersexuality—by the opposite one, so that sexual determination finishes with the other sex after this turning point. The last point is, of course, a problem of genic action."

Bridges developed his idea of "genic balance" as a consequence of his observations on chromosomal nondisjunction, particularly as it illustrated the loss or gain of a fourth chromosome in modifying nonsexual

characters. The similarities and contrasts of this view from that of Goldschmidt are indicated by the following quotation (Bridges, 1932): "From the cytological relations seen in the normal sexes, in the intersexes, and in the supersexes, it is plain that these forms are based upon a quantitative relation between qualitatively different agents—the chromosomes. However, the chromosomes presumably act only by virtue of the fact that each is a definite collection of genes which are themselves specifically and qualitatively different from one another. There are two slightly different ways of formulating this relation, one of which, followed by Goldschmidt, places primary emphasis upon the quantitative aspect of individual genes. The other view, followed by the *Drosophila* workers, emphasizes the cooperation of all genes which are themselves qualitatively different from one another and which act together in a quantitative relation or ratio. Goldschmidt developed his idea through work with the sex relations in *Lymantria* and has sought to extend it to ordinary characters. The other formulation, known as 'genic balance,' was developed from the ordinary genetic relations found in characters. Both are crystallizations of fundamental ideas with which the earlier literature was fairly saturated and no great claim to distinctive originality should be ventured for either or denied for one only. Both are physiological as well as genetic—that is, they are formulations of the action of genes, not merely statements of the genic constitutions of individuals nor merely studies of the way genes act. The physiological side has been emphasized by Goldschmidt and the genetic side by *Drosophila* workers. But Goldschmidt's tendency to represent the view of genic balance as without, or even as in opposition to, such physiological formulation is groundless—as groundless as would be the reciprocal contention that Goldschmidt's theory is only one of 'phenogenetics.'

"A common element in the foundation of both formulations is that if a gene is represented more than once in a genotype the phenotypic effect is expected to be different, though roughly in the same direction as be-

fore and roughly proportional to the quantitative change in the genic constitution."

Since the sexually different types observed by Bridges were accompanied by whole chromosomal differences, he could point to losses or gains of autosomes, with an internal preponderance of genes tending to develop male organs, as balanced by genes of the X chromosomes tending in the direction of producing female organs or of suppressing alternative male organs. The net effect of the X chromosome favoring femaleness, and of the set of autosomes favoring maleness, terminates in the development of male or female, according to the ratio of these determiners in the whole genotype. The effect of the X chromosome goes on the basis of whole numbers 1, 2, 3, 4, as does the similar variation in the sets of autosomes.

Goldschmidt, since he was dealing with

TABLE 1.1

*Chromosomal numbers and kinds for the different recognized sex types of Drosophila*

Type	Chromosomes			X: A Balance
	X	Y	A	
Superfemale	3		2	1.5
Triploid meta-				
female	4		3	1.3
Female*	4		4	1.0
Female	3		3	1.0
Female	3	1	3	1.0
Female	3	2	3	1.0
Female	2		2	1.0
Female	2	1	2	1.0
Female	2	2 + y <sup>s</sup>	2	1.0
Female	2	2 + y <sup>l</sup>	2	1.0
Female	2	2	2	1.0
Female	1		1	1.0
Intersex*	3		4	.75
Intersex	2		3	.67
Intersex	2	1	3	.67
Male	1		2	.50
Male	1	1	2	.50
Male	1	2	2	.50
Male	1	3	2	.50
Male*	2		4	.50
Supermale	1		3	.33

\* These forms are cited by Bridges from his own observations, from L. V. Morgan (1925) and from Sturtevant (unpublished). As yet but limited studies of these forms, which must be rare, have been published. Fourth chromosomes generally, but not always, equal number of the other individual chromosome groups.

males and females of the diploid type, took a corresponding view for the Z chromosomes of his moths with this difference. Since the *Drosophila* chromosome pattern is XY + 2A for the males as contrasted to 2X + 2A for the females and the pattern for *Lymmantria* is ZZ + 2A for the males and ZW + 2A for the females, it was necessary to use a relation which was reciprocal to that of *Drosophila*; the male determining element or elements were assigned to the Z chromosomes. *Lymmantria* has a rather large number of different races found in different geographic locations. Within any one of these races this formulation apparently sufficed. However, from crosses between races it was soon observed that the progeny showed ranges in sexuality all the way from phenotypic males to phenotypic females although these females were actually genetic males. To Goldschmidt, this variation indicated different potencies of the male-determining element. Similar differences were attributed to the female element which he had first assigned to the cytoplasm but for which he later favored a W chromosome location.

In applying this postulate of discrete chromosome contributions to sex according to their number, Bridges made the further assumption that female-producing genes predominate in the X and are scattered through it in more or less random fashion as are the genes affecting so-called somatic characteristics as wing shape or bristle pattern. The quantitative relations for the different chromosomal types, together with their descriptions, are indicated in Table 1.1.

In the formulation of Table 1.1, the X and Y chromosomes are counted separately, whereas a set of A chromosomes (autosomes), is allowed a value of but one even though composed of a 2nd, a 3rd, and a 4th chromosome for the haploid genome. The diploid set of autosomes is given a weight of two, and so on. From these data Bridges observed that the presence or absence of a Y chromosome did not affect the sex types. The X chromosomes and autosomes were, however, important. He held that their importance stood as the ratio of their presumed products to each other. The

ratio is 1 for the perfect female and 0.5 for the perfect male. Between these values intersexual conditions develop. Beyond the value 1, development is overbalanced by excess female genes resulting in the superfemale. Values less than 0.5 create a deficiency in the female elements or excess of male elements and a supermale results. Schrader and Sturtevant (1923) proposed another system. Instead of the ratio of X chromosomes to autosomes, they suggested that a straight difference between the products of the female determining elements of the sex chromosomes and the male effects of the autosomes causes the sex changes. Bridges criticized this system on the basis of the fact that progressive polyploidy did not change the sex type or ratio between the X and autosomes, whereas the numerical difference between them would be progressively increased. While keeping the X:A ratio as descriptive of the ultimate effects of the genes in these chromosomes, he modified their proposed weight from 1:1 for X:A to 1 for the X and 0.80 for the A.

All formulations for explaining sexual differences are beset with a lack of an unbiased quantitative scale by which these differences can be measured. The estimates of the changes in sexuality are left to the insight of the observer. It seems reasonable to suppose that the quantitative relations between the male and female sex determining elements should have intermediate values when the specimens under observation show a mixture of organs of either sex. This agrees with Bridges' considerations of this problem. It is not so clear, however, that the so-called supersexes<sup>2</sup> really are what the names may connote to many readers. The superfemales, with their three X chromosomes and two sets of autosomes, are quite inviable; small in size, wings reduced and irregularly cut on the margins, ovaries developed to only the early pupal stage, and reproductive tracts much reduced in size.<sup>3</sup> The supermales with one X

chromosome and three sets of autosomes are described as resembling males but are sterile. The wings are somewhat spread and bristles less in size. They are late emerging and poorly viable. Neither type can be referred to as superior to normal female or normal male in anatomic development or physiologic functioning. A new type, recently described by Frost (1960), emphasizes this difficulty. Females, called triploid metafemales, Table 1.1 had 4X chromosomes and 3 second, 3 third, and 2 fourth autosomes. Viability was greater than superfemales but still low. Fertility was about 10 per cent. Progeny per female about 10. The flies were like triploids in bristles, eye and wing cells large, sex combs absent. They showed characteristics of superfemales in rough eyes, narrow wings without inner margins, and smaller body build. The distribution of these different *Drosophila* sex types (Table 1.1) showed that optimal development comes when the X:A values are 1.0 and 0.5. Any deviation away from these values tends to make the sex system less rather than more efficient.

In normal *Drosophila* sex differences are probably expressed in every cell making up their bodies. These differences are made visible to us only under special conditions. In adult organ differentiation, the sexual differences are manifest through such things as the body size of the males being about three-fourths that of the females, differences in coloration of the tergites, the appearance of sex combs, the development of the gonads into ovaries and testes, and the formation of a secondary reproductive system composed of several glands and ducts. The origin of these last elements is of particular interest. The ovaries can be distinguished from the testes as early as the second instar through their size and position within the fat body. They are located about two-thirds the larval length back from the mouth parts. The sex combs, on the other hand, take their origin from imaginal discs which are located in the head region, possibly one-third back from the mouth parts. The secondary reproduc-

centage of crossing over and high nondisjunction rate in the XXX + 2A ovaries and a high nondisjunction rate in the offspring (Beadle and Ephrussi, 1937).

<sup>2</sup> Recently termed metafemales by Stern (1959b).

<sup>3</sup> Further development of the ovaries is able to take place in normal XX + 2A hosts. Larval XXX + 2A ovaries transplanted into *fos fos* hosts produce eggs in the recipient host which on fertilization are capable of developing into adult imagos. These imagos show that there is a low per-

tive system for both the males and females takes its origin from a disc at the posterior extremity of the larvae. The testes or ovaries are only brought together with the secondary reproductive tracts during late development in the pupae, whereas the sex combs retain their separate development. The striking action of chromosome balance in sex determination is that all of these organs and others are jointly affected and simultaneously develop directly into either the male or female sexual types. Of these characteristics, the sex combs are particularly trustworthy indices of maleness. In the male, these combs are heavily sclerotized and pigmented. They have 9 to 13 rather blunt teeth on their margins. The normal females lack these sex combs entirely. The intersexes have well developed combs, whereas the triploid females and superfemales lack them. This all-or-none situation resembles that observed in the rest of the block of sexually differentiating characteristics found in normal males or females, save that in the intersexes development may result in the organs of either sex appearing in the primary or secondary reproductive systems. The all-or-none character of the sex combs may, however, be bridged in that the appearance of certain mutations leads to the production of these combs in all of the different sexual types. The combs differ in size, in thickness and length of the teeth, and their number. The sex combs meet the conditions of a quantitative character which may be counted or measured in unbiased units. Thus in the case of sex combs, it is possible to obtain quantitative information on the effects of chromosomal changes on the expression of this form of sexuality.

TABLE 1.2

Mean sex comb teeth for flies having different X and A chromosome numbers and heterozygous for the Hr gene

Sex Type	Chromosome Genotype	Mean Sex Comb Teeth
Males	X + 2A	11.4
Intersex	XX + 3A	9.1
Female	XX + 2A	6.9
Superfemale	XXX + 2A	5.0
Triploid female	XXX + 3A	4.8

Two gene mutations in *D. melanogaster* have aided in this search. The first is the dominant gene, Hr, which causes the male reproductive tract to be added to that of the female when this gene is heterozygous (Gowen, 1942). The extensive effects of this gene on the whole sex determining system have been described by Gowen (1942, 1947) and Fung and Gowen (1957a). The second gene is that of Sturtevant's (1945) transformer, tra, which operates on the female phenotype to convert it to that which corresponds to the male in having sex combs, full male reproductive system including testes, while still leaving the female characteristic body size. These genes are located in the third chromosome of *D. melanogaster*. Crosses between them show allelomorph effects. Combinations of these genes in conjunction with different chromosomal arrangements make possible a series of different sex types which are distinguishable from ordinary males and females (Gowen and Fung, 1957). As some of these types bear sex combs, a quantitative character is furnished in the variation of the sex comb teeth which may be used as an impersonal measure of departure of these types from ordinary males or females. The groups having particular interest are those carrying the Hr gene in heterozygous condition with the X and A chromosomes having various numbers. The mean numbers of sex comb teeth for these various groups are shown in Table 1.2.

Analysis of these data for the contributions made by the sex chromosomes and autosomes to the numbers of teeth found on the sex combs of these different genotypes shows the following relation.

$$\text{Sex combs} = 12.82 - 3.42 X + 0.89 A$$

From this equation it is seen that the X chromosome has four times as much effect on lowering the number of teeth on the sex combs as a set of autosomes. The direction of effect is, as would be expected, increasing the number of X chromosomes tends toward making the individual more female-like in that the sex combs become smaller and less pronounced. Increasing the number of autosome sets on the other hand tends to push the individual toward the male type with



larger sex combs. Some 95 per cent of the variation in sex comb teeth has been accounted for by this equation.

The above equation results when the effect of the sex chromosomes and autosomes is considered as operating on a simple additive basis. It is interesting to consider these effects on the basis of the ratio of sex chromosomes to autosomes as utilized by Bridges. As is customary, the male genotype is given a weight of 0.50, the intersex 0.67, the female 1.00, the superfemale 1.50, and the triploid female 1.00. With these values the data on the sex combs are fitted by the equation

$$\text{Sex combs} = 13.40 - 6.38 X A$$

The fit of this equation to these data shows control of less of the variation in the sex comb teeth. Only 76 per cent of the variation is accounted for by these methods whereas 95 per cent is accounted for when the effects of the X and A chromosomes are considered as additive.

If it is agreed that the condition of the sex combs is a good unbiased measure of the degree of sexuality of the *Drosophila*, it follows that it would be more probable that the genes in the X chromosomes operate additively with those of the autosomes.

### III. Sex Genes in *Drosophila*

#### A. MUTANT TYPES

Bridges' concept of sex determination turned on the action of sex genes located more or less fortuitously throughout the inheritance complex of the species. In *Drosophila* it happens that the major female determining genes seem to be located in the X chromosome and the male determining genes in the autosomes, whereas the Y chromosome seems essentially empty of sex genes. In support of this concept limited data are cited on specific genes affecting the reproductive system or its secondarily differentiated elements and two cases where genes affected the primary reproductive system as a whole. During the interim between 1938 and the present, the numbers of these genes and the breadth of their known effects have been notably increased. Again the genes as a whole affect every phase of sexuality, morphology, fertility,

and physiology. Single genes may occasionally alter both sexes or may frequently affect only male or only female phenotypes. Single genes may appear to influence two or more distinct characteristics observable in the developing flies, although this multiple phenotypic expression may go back to a gene action which is controlling a single event in development. Genes affecting the structural development of either male or female organs frequently are accompanied by sterility of various degrees. A very large category of genes is known only through its effects on sterility of either or both sexes. Experience has shown that when properly analyzed anatomic changes are probably basic to the sterility. In this sense genes for sterility should be considered genes for sex characters. Berg (1937) furnished data on the relative frequency of sterility mutations in the X chromosome as against those in the autosomes, 12.3 per cent mutations in which the males were sterile were found in the X chromosome against 4.5 per cent found in the second chromosome. These results show that the X chromosome has many gene loci occupied by genes capable of mutating to sterility genes which affect males. Sterility is also common for the females but requires more testing. The loci for these genes are widely distributed both within and among the chromosomes.

Genes affecting sex morphology are found in all *Drosophila* chromosomes. Of 17 which have been recently studied; 6 were in the 1st chromosome, 5 in the 2nd, 5 in the 3rd, and 1 in the 4th. Insofar as can be determined these genes are no different than those affecting other morphologic traits. They may be dominant, they may be recessive, and a limited number of them may show partial dominance. They affect a variety of sex characteristics and do not always involve sterility of one or the other sex. The loci occupied by these sex genes may have several alleles, some of which may lead to sterility, others not. Most affect characters like size and development of the ovaries, the characteristics of the eggs, duct development, spermathecae, ventral receptacles, parovaria, paragonia, sex combs, position of genitalia, and so on.

Although *Drosophila* is the leader in furnishing types for analyses of the inheritance basis for sexuality, it is well known that similar conditions exist in other forms of life.

#### B. MAJOR SEX GENES

Major sex genes affecting the dichotomy of the sexes have appeared among the observed mutational types. Sturtevant (1920a, 1921) in *Drosophila simulans* isolated a gene in its second chromosome which when homozygous could convert diploid females into intersexes and render XY males sterile. Phenotypically these intersexes were female-like in that they lacked sex combs and had 7 dorsal abdominal tergites, ovipositor of abnormal form, 2 spermathecae, and lacked the penis. They were male-like in having first genital tergite although abnormal in form, lateral anal plates, claspers, black pigmented tip to the abdomen. The gonads were rudimentary. The gene was recessive and, as expected, showed no effect on *D. simulans* × *D. melanogaster* hybrids.

In 1934 a new intersexual type was observed by Löbedeff in *D. virilis*. Intensive study of this type showed that it depended on a fairly complex inheritance. A 3rd chromosome recessive gene  $ix^m$  at 101.5 converted the XX females into sterile males, showing only one noticeable female characteristic, the presence of a rudimentary 5th sternite. Sterility could be accounted for, even though the internal genitalia were completely male, by the small size of the testes and the degeneration of the germ cells largely at the spermatocyte stage. Observable effects of this gene appeared only in females, XX + 2A. Genetic modifiers were isolated which acted on the  $ix^m/ix^m$  complex. Other genotypes were derived through recombinations of these genes. The resulting phenotypes showed a greater variation of the male-female mosaics. One of these types was sterile but fully hermaphroditic having a complete set of external and internal genitalia of both male and female. Genetically, this type was homozygous for the  $ix^m$  gene but in addition had both a previously found dominant semisuppressor and also a second semisuppressor. Another line having the  $ix^m$  gene homozy-

gous had a full set of male organs but there were rudimentary ovaries attached to the testes. This line showed the dominant semisuppressor as the restraining element on the developmental pattern of the  $ix^m$  gene. Another type was separable in that it was still more female-like, yet had made external genitalia and rudimentary testes. This type was the result of the homozygous  $ix^m$  genes operating in conjunction with 3 different semisuppressors. Extensive embryologic studies were interpreted as indicating that gonads, ducts, and genitalia had started as in females with the XX constitution. Shortly thereafter male organs appeared as new outgrowths from the same imaginal disc. The development of the two sets of organs was then simultaneous but still depended on the gene pools present in the particular strain.

Another intersexual type appeared in *D. pseudoobscura* as a mutation, presumed due to a single dominant gene (Dobzhansky and Spassky, 1941). In a series of cultures having "sex ratio," two cultures gave 234 females, 7 males, and 266 intersexes. The females' progeny transmitted only the normal condition to their  $F_2$  progeny. The males were sterile presumably because they lacked a Y chromosome. The intersexes were also sterile so that further study of the genetic condition became impossible. The evidence, however, is interpreted as showing that the intersexes were transformed females which had inherited a dominant gene governing this condition. The intersexes were characterized by two sets of more or less complete genital ducts and external genitalia but only one pair of gonads. One set of ducts and genitalia was almost always more female-like and the other more male-like. Sex combs were present, the distal comb had 2 to 4, and the proximal 4 to 6 teeth, compared with the normal male number of 4 to 7 on the distal and 6 to 9 on the proximal comb. Body development was more like that of the female. Cytologic examination showed two of the intersexes had two ovaries each. One of these two had a rudimentary testis. The chromosome complement was 2X + 2A.

A dominant gene which causes intersexuality in diploid females of *D. virilis* was established by Briles. Stone (1942) located

this gene in the second chromosome. Price (1949) placed the gene within the second chromosome near the locus of "brick" by inducing crossing over in males by exposing them to x-rays. Newby (1942) extensively studied the embryologic sequence in development of the organs of these intersexual types. The  $Ix^B$  gene did not affect the males,  $XY + 2A$ , but did change the females  $XX + 2A$  into intersexes when it was in the heterozygous condition. The intersexuals had 9 tergites; the first 6 were like those in the normal female and the last 3 were small and irregularly formed. There were 6 sternites, the first 5 being normal, but the 6th malformed. Anal valves were lateral as in the male but a third small valve was also present at the ventral side of the anus. The plates forming the claspers were of irregular pattern and found ventral to the anus. The vaginal plates were often extruded into a genital knob and were below the claspers. The knob occasionally became heavily pigmented. The internal organs ranged from nearly female through those which were of hermaphroditic type containing representative organs of both sexes to individuals almost wholly male. Newby concluded that intersexuality expresses itself as a response to the developmental pressures of both sexes, not as development in the one direction followed by a change.

Gowen in 1940 established a stock carrying the dominant gene  $Hr$  which had appeared as a mutant in one of his cultures of *D. melanogaster*. This gene affected diploid females of  $XX + 2A$  type but not the males of  $XY + 2A$  constitution. In the presence of the  $Hr$  gene the diploid phenotype of the females changed into a sterile type with male secondary reproductive system associated with the female counterpart. The first 6 segments were complete with 6 spiracles. The 7th was small with spiracle. The 8th was small but without spiracle. Sternite forming rudimentary ovipositor was usually protruded. Ninth and 10th segments resembled those of males with large tergal plates. Claspers were abnormal and had a pair of small plates flanking the anus majorly in vertical position. Organs formed, although sometimes modified or missing, included: sex combs of 6.9 long slender

teeth, gonads distinguishable from those of the ordinary male or female in the 3rd and possibly the 2nd instar, genital ducts male and or female, male accessory gland, penis deformed, sperm pump, vas deferens, spermatheca, ventral receptacle often displaced, and occasionally parovaria. The primary gonads were often abnormal ovaries but in rarer instances bore a crude resemblance to testicular tissue. The yellow of the testes was frequently present as material clinging to the ovary.

Superfemales with one dose of the  $Hr$  gene had sex combs and developed parts of both the male and female external and internal reproductive systems. Sex combs had an average of 5 long and slender teeth. Abdominal segment 8 developed as in the female, and formed the vaginal plate. The latter was abnormal in shape, ordinarily becoming a sclerotic protuberance. Segments 9 and 10 developed more as in the male but were incomplete and abnormal. The genital arch did not develop but the inner lobe of tergite 9 showed irregular and abnormal growth as for the claspers. Segment 10 developed, as in the males, into longitudinal plates flanking the anus. The internal genitalia were underdeveloped but consisted of mixtures of male and female organs. Gonads were rudimentary but generally consisted of a pair of ovaries with small traces of yellow pigmentation.

The triploid fly with one dose of the  $Hr$  gene was largely female with developed ducts, ovaries and eggs, but was sterile. The male characteristics were small sex combs and dark abdominal plates. In superfemales, sex combs were present and teeth were intermediate between those of the diploid female and triploid female. The gene showed a dosage effect in triploids which was less than that observed in diploids and was in relation to the relative balance of the gene with its normal alleles, 1:2 for the triploid and 1:1 for the diploid. The developmental effects of  $Hr$  as well as the pigment producing potentialities of testes, ovaries and hermaphroditic gonads have been discussed by Fung and Gowen (1957a, b).

$Hr$  has been shown to be allelomorphous to a recessive gene,  $tra$ , described by Sturtevant (1945) and known to be located in the

3rd chromosome. The location of this allele, tra, is at 44 to 45 or between the genes scarlet and clipped. When homozygous the gene transformed diploid females into sterile males. Heterozygotes showed no detectable differences from normal females of XX constitution. Males XY homozygous for tra or heterozygous for it were indistinguishable from normal males. The homozygotes XX, tra tra were female in body size, but otherwise were nearly male in appearance. They had fully developed sex combs, male colored abdomens, normal male abdominal tergites, anal plates, external genitalia, genital ducts, sperm pumps, paragonia, and showed the usual rotation of the genital and anal segments through 360 degrees. They mated with females readily and normally. The testes, however, although normal in color, elongated, curved, and attached to the ducts were of small size. Testis size was never that found in normal brothers. The addition of a single Y or two Y's did not alter fertility.

The triploid females 3X + 3A homozygous for tra, had large bodies, ommatidia and wing cells. They resembled the diploid homozygous tra individuals in having male external genitalia, well developed ejaculatory ducts, sperm pumps, and accessory glands, testes elongated but narrower than those of normal males, and sex combs averaging about 9.6 teeth. They mated with females but were completely sterile.

Triploids with one or two doses of tra were like wild type triploids in having no sex combs and being female throughout. Intersexes having one or two doses of tra were similar to intersexes having only wild type genes in the locus.

Sturtevant obtained one superfemale which was homozygous for tra. It had male genitalia and sex combs with only about half the normal number of teeth. This individual argues for a greater balance toward the female side of sexual development than either the diploid or triploid females previously discussed. The evidence is, however, contradictory to that furnished by the Hr gene as indicated earlier.

A combination of two or more genes, Beaded and various Minutes, having well known phenotypic effects, has sometimes

produced phenotypes which have been interpreted as peculiar, low grade types of intersexuality in males (Goldschmidt, 1948, 1949 and 1951). The data showed that the Beaded cytoplasm favors the low grade intersexual male whereas the Minute cytoplasm favors the reduced male with the heterozygote being intermediate. Just how far these types may be related to the other types strongly affected by specific genes is a matter of question, having at least other interpretations (Sturtevant, 1949).

In 1950, Milani trapped an inseminated female of *D. subobscura* which segregated intersexual progenies. Spurway and Haldane (1954) studied these intersexual types. A recessive guiding development toward these intersexes was located on the 5th chromosome of *subobscura*. When present it caused the XX homozygous females, ix/ix + 2A, to have sex combs on both the first and second tarsal joints. The numbers of teeth making up the sex combs were reduced as also were the sizes of the teeth. The illustration in Spurway and Haldane's (1954) paper indicates that the number of teeth was 7 on the first tarsal joint and 5 on the second joint, whereas the sex combs of the males had 11 teeth on the first joint and 9 on the second. A series of changes were observed in the genital plates which graded from those resembling true females to those approaching the male type.

#### C. OTHER CHROMOSOME GROUP ASSOCIATIONS: *DROSOPHILA AMERICANA*

*D. americana* has 4 chromosomes in the female genome and 5 chromosomes in the male genome. As compared with *D. virilis* the X chromosome is fused with the 4th chromosome and the 2nd chromosome is fused with the 3rd, the 5th and 6th chromosomes are free in the female, whereas in the male genome the Y chromosome, 4th, 5th and 6th chromosomes are free and the 2nd and 3rd fused. Stalker (1942) has shown that the three female genomes are balanced and lead to triploid females as they do in *D. melanogaster*. *D. americana* triploids differ from their diploid sisters in having bigger ommatidia, larger wing cells and somewhat larger bodies. When these triploids are bred to diploid males they give

rise to 6 chromosomally different types of offspring: diploid males, diploid females, triploid females, intersexes, females carrying a Y and a male limited 4th chromosome but otherwise diploid, and tetraploid females. All intersexes cytologically show a Y and a 4th chromosome present. Intersexes without the Y are presumed also without male limited 4th chromosomes and would be expected to be inviable or very weak. No supermales or superfemales, that would correspond with those found in *D. melanogaster*, were observed so are presumed to be inviable due to unbalance for the 4th chromosomes. Among 948 progeny of triploid females  $\times$  diploid males there were 9 individuals that were phenotypically abnormal females. They had slightly spread, ventrally curved wings with slightly enlarged wing cells. In 8 of the 9 the first section of the costal vein was shortened so that no junction was made with the first vein at the distal costal break. Heads were large with rough eyes, thoraxes shortened, legs frequently malformed, and abdomens small with unusually wide 7th sternites. Genitalia were apparently normal with well developed ovaries. This type carries three doses of any genes contained in the 4th chromosome to two doses of the genes in the other chromosomes. Its phenotype represents a trisomic condition.

The sex characteristics of the flies observed in *D. americana* seem to follow the same patterns as those of *D. melanogaster* as judged by the numbers of the X chromosomes and autosomes. A Y chromosome in the intersex was not observed to affect sex expression. The intersexes could be grouped into six classes ranging from extreme male type to the most female type. The male type showed largely male organs, courted females, and had motile but nonfunctional sperm. The most female type had nearly normal ovipositor plates, well developed uterus, ventral receptacle, spermathecae and oviducts. At least one gonad showed egg strings, although a small patch of orange-red tissue was present at the tip. Two types of chromosomes were observed in the nuclei of these extreme female type intersexes; those like the chromosomes in any normal diploid cells and some which

were so swollen as to be almost unrecognizable. Such swollen chromosomes were not found in the other classes of intersexes or in diploid or triploid individuals. They are suggestive of some noted by Metz (1959) in *Sciara*. Most of the intersexes were of the male type, 45 per cent, with decreasing numbers for each of the other five classes until those in the most female class constituted only about 4 per cent of the total.

#### D. LOCATION OF SEX-DETERMINING GENES

The problems of isolating and determining the modes of action of the factors normally operating in sex determination have received extensive study since they were reviewed by Bridges in 1939: Patterson, Stone and Bedichek (1937), Patterson (1938), Burdette (1940), Pipkin (1940-1942, 1947, 1959), Poulson (1940), Stone (1942), Dobzhansky and Holz (1943), Crow (1946), and Goldschmidt (1955). From his work on *Lymantria dispar*, Goldschmidt concluded that sexual differentiation was controlled by a major male factor, M in the Z chromosome and a factor F directing development toward the female and at first assumed to be in the cytoplasm but later considered to be in the W chromosome. The heterogametic female of this species would then be FM and the male be MM. In considering this problem, Goldschmidt attempted to distinguish between the sex determiners responsible for the F/M balance and modifiers affecting special developmental processes (Goldschmidt, 1955). At the other extreme Bridges' study of triploids led him to consider that sex in *Drosophila* was determined by the interaction of a number of female tendency genes found largely in the X chromosome and of genes having male bias located largely in the autosomes. These numerous genes were considered as being distributed throughout the whole inheritance complex. Search for the more exact locations of these genes within the different chromosomes of *Drosophila* has largely taken the form of determining the variation in sex types as induced by the addition or deletion of various pieces of the different chromosomes to either the normal male, normal female, or triploid complexes.

The sections of the chromosomes added were derived from previous translocations generally to the 4th chromosome and were of varying lengths determined through cytologic and genetic study. Summaries of these comparisons are found particularly in the papers of Pipkin (1940, 1947, 1959). In their search for a major female sex factor in the X chromosome, Patterson, Stone and Bediehek (1937), Patterson (1938), Pipkin (1940), and Crow (1946) finally were unable to show that any single female sex determiner, located in the sex chromosome, was of primary importance to sex. Evidence for multiplicity of genes with a bias toward female determination was found by Dobzhansky and Schultz (1934) and by Pipkin (1940). They were able to transform diploid intersexes into weakly functioning hypotriploid females by the addition of long fragments of the X chromosome to the  $2X + 3A$  intersex complement. Short sections of the X chromosome in some cases shifted the sex type in the female direction. Pipkin found that additions of short X chromosome sections, to the  $2X + 3A$  chromosome sets, although covering in succession the entire X chromosome, were insufficient to make the flies other than of the intersexual type. Longer and longer fragments from either the left or right end of the X chromosome caused a qualitatively progressive shift toward femaleness. Weakly functional hypotriploid females resulted when either right- or left-hand sections of two translocations with t-lz (17) and lz-v (W13) breaks were present in the  $2X + 3A$  chromosome complement. These duplication intersexes possessed 1 or 2 sex comb teeth when reared at 22°C. and up to 5 well developed teeth when reared at 18°C. These facts give support to the multiple sex gene theory of Bridges or at least that quantitative differences in sex potencies exist within the X chromosome. This conclusion was further strengthened by the hypointersexes lacking a short portion of one of their two X chromosomes although possessing three of each autosome, inasmuch as these types were shifted strongly in the male direction. These studies of the X chromosome show that several parts of this chromosome are concerned with female dif-

ferentiation and that the effects are irregularly additive.

Similar search of the auto-some II and III for genes of male potency showed that small shifts in the male direction were found in hyperintersexes for several short regions of chromosome III but for none of chromosome II (Pipkin, 1959, 1960). Three slightly different right-hand end regions of chromosome III produced the largest shifts in the male direction in hyperintersexes, but no increase in number of sex comb teeth. These changes were comparable with those produced in the female direction by the addition of very short sections of the X-chromosome to the  $2X + 3A$  intersex complement. On the other hand, none of the seven different hypointersexes lacking a short section of the 3rd chromosome from the  $2X + 3A$  complement showed a shift in the female direction. This is rather surprising as hypointersexes for two short regions in the X chromosome were shown by Pipkin (1940) to shift the sex type in the male direction as was to be expected. From these results Pipkin (1959) derives the conclusion that 3rd chromosome aneuploids as well as those of the 2nd chromosome and X chromosome support the deduction that dosage changes of portions of the X chromosome are more powerful than dosage changes of portions of either of the large autosomes in affecting sex balance. This view receives further support through changes of size and number of sex comb teeth as observed in the chromosomal types carrying the gene Hr and reviewed earlier.

Influence of the Y chromosome on sexual differentiation has generally been ruled out as XO nondisjunctional flies are male although they are sterile (Bridges, 1922). Similarly Dobzhansky and Schultz (1934) ruled out the Y chromosome as an effective influence on sex types of triploid intersexes of *D. melanogaster* since the mean sex type of  $Y + 2X + 3A$  intersexes did not differ significantly from the sex types of siblings  $2X + 3A$ .

The steps taken in the studies of chromosome IV are of interest. Dobzhansky and Bridges in 1928 concluded that the 4th chromosomes play no part in sex determination in *D. melanogaster*. The evidence was

of two kinds. Triploid females were outcrossed separately to males of two diploid stocks. The triploid daughters from these crosses were again crossed to males like their fathers. This repeated outcrossing to the different stocks resulted in a shift in the grade of the intersexes in both cases, in one case to a very high proportion of extreme male-like intersexes and in the other to nearly as high a proportion of extreme female-type intersexes. These results were interpreted as showing that the grade of development of the sexual characters was dependent on genetic modifiers. The second experimental test consisted of subjecting a triploid stock to selection toward a line which produced a high proportion of extreme male type intersexes and to another line which would have a high proportion of extreme female type intersexes, each being much higher than the original stock. The procedure established a line with a high proportion of extreme male type and another line which was not so extreme in its proportions but was definitely higher in female type intersexes than the original stock. Again these results were interpreted as indicating the selection of modifying genes of unknown positions within the inheritance complexes.

This evidence had been preceded by Bridges' (1921) discussion in which he wrote "the fourth-chromosome seems to have a disproportionately large share of the total male-producing genes; for there are indications that triplo-fourth intersexes are predominately of the 'male-type', while the diplo-fourth intersexes are mainly 'female-type'." In 1932, Bridges concluded for *Drosophila* intersexes that, in spite of the favorable genetic checks, in repeated and varied tests, it has been impossible to state with any assurance whether the 4th chromosome is or is not a large factor in the variability encountered.

In our own work a stock of attached X triploids has for many years consistently produced only male type intersexes. This is in contrast to what we frequently see within other lines of triploids as made up utilizing the cIIIg gene (Gowen and Gowen, 1922). Lines established from these triploids ordinarily have three intersexual types: male,

intermediate, and female. These lines, however, may be subjected to selection in both directions. In our experience, male intersex lines are established rapidly and remain relatively permanent. On the other hand, female intersex lines take many more generations and are less stable. These lines have been extensively examined for their 4th chromosome constitutions (Fung and Gowen, 1960). The male intersex lines seldom show more than two 4th chromosomes. On the other hand, the female intersex lines rarely show two 4th chromosomes but generally have more than three, the number sometimes going as high as four. More tests are needed but the evidence would seem to indicate that the fourth chromosome does have sex genes. These genes, contrary to the first notion of Bridges, are more frequently of the female determining type than of the male determining type. This would make the 4th chromosome like the X in that it carries an excess of female influencing genes and is not like the rest of the autosomes which have an excess of male determining genes. These observations are of particular interest in view of Krivshenko's (1959) paper. In this investigation on *D. busckii*, cytologic and genetic evidence was presented for the homology of a short euchromatic element of the X and Y chromosome with each other and also with the 4th chromosome or microchromosome of *D. melanogaster*. This conclusion is based on (1) observed somatic pairing of the X and Y of *D. busckii* by their proximal ends in ganglion cells and the conjugation of the short euchromatic elements of these chromosomes at their centromeric regions in the salivary gland cells; (2) the presence in the short Y chromosomal element of normal allelomorphs to four different mutant genes of the short X chromosomal element; (3) the presence in the short element of the *D. busckii* X chromosome of chromosome IV mutants: *Cubitus interruptus*, *C'ell* and *shaven* of *D. melanogaster*. These considerations furnish proof for the homology of this X chromosomal element with the 4th chromosome of *Drosophila*.

These observations of Krivshenko support our findings that the 4th chromosome of *D. melanogaster* has an excess of female

determining functions. It would further show that autosomes may behave differently with regard to their sex-determining properties according to the chance distribution of sex genes which happen to fall within them as they do in *Rumex* (Yamamoto, 1938). The finding that the chromosome IV has a bias toward female tendencies further strengthens Bridges' multiple sex gene theory and weakens the theory of an all-or-none action of the whole X chromosome.

#### IV. Sex under Special Conditions

##### A. SPECIES HYBRIDITY

Hybrid progeny coming from species crosses are apt to represent but a very few of the possible genotypes of the total number that conceivably could come from the gene pool. The hybrid phenotypes may display three kinds of characteristics. The common set is that derived from genes in either or both parents through ordinary meiotic segregations and dominance. The second set shows intermediate development of the characters found in the two parent species. The third set of characters that complete the animal is new to those observed in either parent species. These new characters may be the loss of a few dorso-central and scutellar bristles, broken or missing cross veins, or abnormal bands in the abdomen as in *D. simulans* x *D. melanogaster* hybrids (Sturtevant, 1920b), extra antigenic substances as found in dove hybrids (Irwin and Cole, 1936), or more numerous characteristics as in the mule. Frequent among these new characteristics is sterility. The sterility may extend to either or both sexes and affect the secondary sex ratios. As Sturtevant (1920b) points out, crosses between the domestic cow and male bison give male offspring with humps derived from the bison which are so large as to prevent their being born alive. The female hybrids lack these humps and are consequently born normally. The abnormal sex ratio observed at time of birth is due to causes external to the hybrid itself and attributable to the structure of the mothers.

A comparable case was found during the study of female sterility in interspecies hybrids of *Drosophila pseudoobscura* in which

Mampell (1941) showed that in the hybrids of certain strains, the females produced no or few offspring because of interspecies lethal genes connected with a maternal effect. Comparable cases as well as those dependent on other mechanisms are known for other groups. The progeny may also be altered to give new sex types, generally intersexes. These intersexes often replace either the male or the female sex group. However, despite their apparent relation, the changes in the sex ratio and the appearance of intersexes can have different causes. *D. simulans* x *D. melanogaster* hybrids emphasize that there may be no relation between the peculiar hybrid sex ratios and the intersexes since extreme differences in sex ratio occur but no intersexual types.

Species, however, may have natural differences in the sex potencies of their X chromosomes and/or their autosomes. In crosses between *D. repleta* and *D. neorepleta* involving a sex-linked recessive white-eyed mutant type of *D. repleta* Sturtevant (1946) obtained about 15 per cent fertile matings in 500 mass cultures, a total of 532 females to 635 males. All progeny as expected were wild type in character. The males, however, had long narrow testes and were totally sterile, a condition later shown to be due to a gene in the X chromosome located near the white locus. Females suggested intersexuality in having three anal plates instead of the usual two. Mating of F<sub>1</sub> hybrid females to white *D. repleta* males gave 9 per cent fertility, the 179 offspring being distributed as 70 wild type females, 9 white females, 42 wild type males, and 58 white males, although the expectation for the classes was equality. Evidence indicates that some of the 9 white females were intersexes as were possibly some of the white males. The wild-type males again had the long narrow testes and sterility of the F<sub>1</sub> male progeny. Wild type females were moderately fertile. By continued backcrossing to *D. repleta* males having white or white-singed, a female line was picked up which continued to have the unusual sex ratios but had more fertility. It was presumed that the *D. neorepleta* gene responsible for the unusual ratios was originally associated with another gene that decreased fertility



in females largely of *D. repleta* constitution and that the foundation female for the more fertile line came as a result of a cross-over between an infertility gene and that responsible for the unusual sex ratios. Continued back crosses of females of this line to white *D. repleta* males have been made. Out of 33 fertile cultures, 16 gave approximately equal ratios of wild-type and white females, wild-type and white males; and 17 gave 472 wild-type females, 5 white females, 63 white intersexes, 482 wild-type males, and 339 white males. The white females presumably represented crossovers between the loci of white and the critical gene in the X derived from *D. neorepleta*. The intersexes were of extreme type with gonads very small (rudimentary ovaries in those cases where they were found at all). External genitalia were missing or of abnormal male type. Other somatic characteristics included weakness which prevents emergence and accounts for the loss of about 88 per cent of the flies expected in that class. The intersexual condition was suggested as being caused by an autosomal dominant gene derived from *D. neorepleta* which so conditions the eggs before meiosis that two *D. repleta* X chromosomes result in the development of intersexes rather than females. The action of this gene occurs before meiosis and may in fact be absent from the intersexes themselves. This was confirmed by crosses of white brothers of the intersexes to pure *D. repleta* females when the offspring were normal for both sexes; but when these  $F_1$  daughters were mated to *D. repleta* males only intersexes and males resulted. This last cross further showed that although this gene was derived from *D. neorepleta* in *D. neorepleta* cytoplasm, the *D. neorepleta* cytoplasm was not necessary for the intersexes to result. The case also has an important bearing on the location of the sex-determining factors, for in this cross the characteristics were only secondarily governed by the cytoplasm through earlier determination by genes of the mothers' nuclei.

Significant parallels are found between the autosomal gene of *D. neorepleta* and the third chromosome Xc gene of *D. melanogaster* (Gowen and Nelson, 1942) described in the section on high male sex

ratio. The *D. neorepleta* gene caused the cytoplasm of the eggs laid by mothers carrying it to become more male potent. The female potencies of two X chromosome *D. repleta* zygotes were unable to balance these male elements. Many died late in development. Those able to emerge became intersexes. The Xc gene also sensitizes the cytoplasm of all eggs of mothers carrying it causing any  $2X + 2A$ ,  $3X + 3A$ ,  $3X + 2A$  or  $2X + 3A$  intersexes of female type to die in the eggs at 10 to 15 hours whereas males  $XY + 2A$  and male-type intersexes live.

Other mechanisms for causing sex and sex ratio changes are known, *i.e.*, Cole and Hollander (1950), but few are as well worked out as that of *D. repleta* x *D. neorepleta*. New mechanisms will certainly be found for the opportunities for genetic analysis of sex in hybrids are many.

#### B. MOSAICS FOR SEX

Recent genetic work has emphasized the fact that individual *D. melanogaster* may be composed of cells of more than one genic or chromosome constitution. The main type of sex mosaic is the gynandromorph composed of cells of female constitution on one side,  $XX + 2A$ , and male,  $X + 2A$  on the other, the loss of the X chromosome coming at an early cleavage (Morgan and Bridges, 1919; L. V. Morgan, 1929; Bridges, 1939). The mosaic areas are large since the cells of each type may be in nearly equal numbers.

At the other extreme Stern (1936) has shown that phenotypic mosaics may develop as a consequence of the somatic chromosome pairs crossing over at late stages in embryologic development. Special genes, Minutes, materially increase the frequencies of these crossovers. The proportion of the body occupied by the cross-over type cells is small because crossing over takes place so late in development.

Recently another agent in the form of a ring chromosome has been discovered which greatly increases the production of sex mosaics. Some ring chromosomes are relatively stable whereas others are quite unstable, the instability depending to some extent on aging of the eggs and environmental factors (Hannah, 1955). The instability is manifest

by frequent gynandromorphs, XO males, and dominant lethals among the rod and ring zygotes. It has been suggested that the instability is due to heterochromatic elements. Hinton (1959) has observed the chromosome behavior of these types in Feulgen mounts of whole eggs that were in cleavages 3 to 8. He found strikingly abnormal chromosome behavior in these cleaving nuclei. For some cell divisions chromosome reproduction was interpreted as being through chromatid-type breakage fusion bridge cycles. As a result of this behavior mosaics are formed which are intermediate between those of the half gynandromorphs and those which occur much later because of somatic crossing over. In terms of volume of cells included, the abnormal types may include only a few cells of the total organism, a fair proportion of the cells, or a full half of the whole body. These unstable ring chromosome mosaics may be a part of the secondary reproductive system or for that matter any other region of the body. When the mosaic cells are incorporated in the region of sex organ differentiation male or female type organs or parts of organs may develop as governed by the cell nuclei being X, XX or some fraction thereof.

Gynandromorphs appear sporadically and rarely in many species but in some instances genes which activate mechanisms for their formation are known. In the presence of recessive homozygous claret in the eggs of *D. simulans*, gynandromorphs constitute a noticeable percentage of the emerging adults. The gene nearly always operates on the X received from the mother causing it to be eliminated from the cell. The resulting gynandromorphs are similar to those of *D. melanogaster*. The fact that the claret gene should affect the X and a particular X chromosome is suggestive of the manner in which given chromosomes are eliminated in *Sciara*. Other types of sex mosaics will be found in the descriptions of other species, particularly in the Hymenoptera.

#### C. PARTHENOGENESIS IN DROSOPHILA

Parthenogenesis is of interest as it changes the sex ratios in families and brings to light new sex types and novel methods

for their development (Stalker, 1954). A survey of 28 species of *Drosophila* showed a low rate of parthenogenesis in 23 species. Adult progeny were obtained for only 3 species. For *D. parthenogenetica* the original rate was 8 in 10,000 whereas that for *D. polymorpha* was 1 in 19,000. These rates could be increased by selection of higher rate parents: 151 and 70 per 10,000 unfertilized eggs of the first and second species respectively.

*D. parthenogenetica* diploid virgins produced diploid and triploid daughters as well as rare XO sterile diploid males. Triploid virgins produced diploid and triploid females and large numbers, 40 per cent, of sterile XO diploid males. Diploid virgins heterozygous for sex-linked recessive garnet produced homozygous and heterozygous diploid females as well as  $+/+g$  and  $+g/g$  triploid females. No homozygous wild-type or homozygous garnet triploid females or garnet mosaics were found. Diploid females crossed to fertile diploid males produced few if any polyploid progeny or primary X chromosome exceptional types. Of the unfertilized eggs from diploid virgins which started development, 80 per cent died in late embryonic or early larval stages. The parthenogenesis in diploid females depended on two normal meiotic divisions followed by fusion of two of the derived haploid nuclei to form diploid progeny, or the fusion of three such nuclei to form triploid progeny. In the triploid virgins similar fusions of the maturation nuclei may produce diploid and triploid females but the large number of diploid XO sterile males were presumed to be the result of cleavage without prior nuclear fusion. Such cleavages without fusion in eggs of diploid virgins would lead to the production of haploid embryos. They were presumed responsible for the large early larval and embryonic deaths. These observations have been confirmed by the study of Sprackling (1960) involving some 2200 eggs at various stages of cleavage. Evidence from XXY diploid virgins indicated that binuclear fusion in unfertilized eggs involved two terminal haploid nuclei or two central nuclei. The fact that tetraploids were not observed as progeny of triploid virgins was considered indicative of relative inviability of this

type. Successful parthenogenesis was under partial control of the inheritance as 80 generations of selection increased the rate about 20-fold. Similarly outcrossing to bisexually reproducing males and reselection resulted in both pronounced increases in and survival of the parthenogenetic types.

Carson, Wheeler and Heed (1957) and Murdy and Carson (1959) have established a strain of *Drosophila mangabirai* with only thelytokous reproduction. Males have been captured in nature but are rare. Fecundity of the virgin females is low but the egg hatch is 60 per cent and 80 per cent survive to adult stage. The progeny of the virgins are always diploid. In meiotic spindle formation *D. mangabirai* differs from other *Drosophila* species in that its orientation increases the probability for fusion of two haploid nuclei into structurally heterozygous diploid females. The study of Feulgen whole mounts of freshly laid eggs indicated automictic behavior with two meiotic divisions followed by a fusion of two of the four haploid meiotic products. The absence of adult structural homozygotes in wild populations is probably explained by death during early development and by possible fusion of second division meiotic products derived from different secondary oocytes. Stalker (1956a) postulated such selective fusion in order to account for the heterozygous condition in females of *Louchoptera dubia*, an automictic, parthenogenetic fly in which males are rare or unknown.

A case in which phenotypically rudimentary females, supposed homozygous for *r r* give rare and unexpected type progeny, has suggested that polar body fusion may also take place in *D. melanogaster* (Goldschmidt, 1957). The rudimentary mothers producing the peculiar type are interpreted as formed by a most unusual series of events: a fertilization nucleus derived from the fusion of an *r* containing egg fertilized by an *r* containing sperm and a polar copulation nucleus derived from the fusion of a polar body containing an *r* genome and one having wild type. Both cell types become incorporated into the ovary. The progeny which come from these supposed rudimentary mothers are presumed to be derived from the maturation into eggs of the cells

derived from the heterozygous polar copulation nuclei. If these progeny-producing rudimentary mothers arise in the presumed manner they give the basis for a parthenogenetic mode of reproduction and the sex types which have been described in other *Drosophila* species by Stalker and Carson.

There are similar, as well as other forms of parthenogenesis which affect sex (Smith, 1955) or assist in maintaining triploid conditions (Smith-White, 1955). A number of these types have been reviewed by Suomalainen (1950, 1954). The reader may be referred to this material for other cases and chromosome behaviors.

#### D. SEX INFLUENCE OF THE Y CHROMOSOME

The first function discovered for the Y chromosome in *D. melanogaster* was that it was necessary to male fertility (Bridges, 1916). Two and possibly more Y chromosome-borne, genetic factors were involved (Stern, 1929). Gamete maturation when these factors were lacking ceased just short of the sperm's becoming motile (Shen, 1932). The motility conferred on the sperm by the presence of the Y chromosome factors was fixed for the testes at an early stage of development as transplantation experiments, sterile testes to fertile larvae and fertile testes to sterile larvae, showed motility to be a property determined by early localized somatic influences on the developing gametes or predetermined in the diploid phase (Stern and Hadorn, 1938). This Y chromosome function was sex limited, because females without a Y were the normal fertile females and those with an extra Y also were fertile.

Neuhaeus (1939) followed by Cooper (1952, 1959) and Brosseau (1960) further analyzed the Y chromosome for fertility loci. The latter showed at least two fertility loci on the short arm and five on the long arm of the Y chromosome. Data are compatible with a linear order of the genes. An additional fertility factor common to the X and Y was suggested. The Y chromosome fertility factors consequently fall in line with Bridges' concept of multiple gene loci distributed in a more or less random manner which may affect sex.

The Y chromosome has other attributes which help to explain its significance to sex-

ondary if not primary sex characteristics. As with many other species it has loci for genes which are also found in the X chromosome, *i.e.*, bobbed, as well as a limited number of bands in the salivary gland chromosome. Nucleolus organizers and at least two specialized pairing organelles similar to those in the X chromosome are found within the Y chromosome (Cooper, 1952, 1959). One of the most significant properties is the effect of extra Y chromosomes on the variegation observed for various gene phenotypes either in the normal chromosome pattern or in that accompanying translocation. In variegation one Y chromosome as extra to the normal complex is sufficient to eliminate or more rarely to much reduce the variegated expression (Gowen and Gay, 1933). When the Y chromosomes are 2 above the normal complement, the phenotypes gain two new features (Cooper, 1956). Both males and females become variegated in the expression of their eye characteristics. The males become sterile. These effects are unexpected for they are counter to any previous trends in the Y effects on these characteristics. They have reversed the direction of the effects as established by the two previous chromosome types. The variegation of the  $XX2Y + 2A$  females and  $X3Y + 2A$  males resembles that of the  $XX + 2A$  females and  $XY + 2A$  males but is more extreme, whereas the  $XXY + 2A$  and  $X2Y + 2A$  are largely nonvariegated. The fertility relations are equally aberrant: the  $X3Y + 2A$  males have the same type sterility through loss of sperm motility as that of the  $XO + 2A$  males. Bundles of sperm are formed but they do not become motile. Full-sized Y chromosomes are not required to bring about these effects, because females having a whole Y plus a piece of a second, or males with 2Y plus a piece of a third, will show the effects.

The fractional Y chromosomes furnish opportunities to test for the partial independence of the variegation and sterility effects. The two Y hyperploid males differ in their degree of fertility according to the fraction of the Y chromosome which may be present whereas the effects on variegation may be constant among groups. This is in accord with the sterility being in part

independent of the factors causing the variegations. Similarly, the variegations may be shown to be partially free of the action of some elements that are not themselves members of the two sets of factors influencing fertility in the normal male.

Other phenotypic irregularities appear; eye facets may be roughened, legs shortened, and wing membranes become abnormal. On the negative side two extra Y chromosomes in females homozygous for the transformer gene, tra, do not increase in maleness or function.

The variegations of the so-called V-type position effects with translocations are suppressed, as in the normal type described, by one extra Y but are nonetheless variegated when two extra Y chromosomes are present. That these effects are caused by there being two supernumerary Y's is indicated by the fact that  $XX2Y$  females are fertile and  $X3Y$  males sometimes lose a Y chromosome in their germinal tracts and become fertile. A number of mechanisms have been suggested to account for these results but most have proven unsatisfactory. A balance interpretation for the X, Y and autosomes like that for sex, as suggested by Cooper (1956) is compatible with the somatic cell variegations for euchromatic loci transferred to the heterochromatic regions and the sterility-fertility relations expressed by the different chromosomal types.

The variegation effects of the Y chromosome take on further significance. Baker and Spofford (1959) have shown that 15 different fragments of the Y chromosome when studied for their contributions to variegation differ in their effects with the differences often not related to the size of the fragment, thus indicating that the Y chromosome has linearly differentiated factors capable of modifying the variegated phenotype.

Other indications of genetic activity of the Y chromosome were given by Aronson (1959) in her study of the segregation observed in 3rd chromosome translocations. A deficiency for the region of the 3rd chromosome centromere is lethal when homozygous. Both males and females are fully viable when this deficiency is heterozygous.  $XO$  or haplo IV deficient males die. How-

ever, in the presence of a Y chromosome the deficient haplo IV males become viable. The lability of this last class indicates that the Y chromosome is genetically active, can compensate for the autosomal deficiency, and thus alter the progeny sex ratio.

In *D. virilis* the situation is somewhat different from that observed by Cooper in 1956 in *D. melanogaster*. Baker (1956) has shown that, in a translocation, males having two Y chromosomes plus a Y marked with a 5th chromosome peach are fertile. These results seem to indicate a species difference in the effect of the extra Y on fertility or the Y with the inserted peach locus is not a complete Y and in consequence the true composition of these males is  $X + 2Y$  plus a fragment of the Y. The X chromosomal associations in the multichromosomal types are shown to be by trivalents or by tetravalents. The segregation data indicate that the pattern of disjunction of trivalents is a function of the particular Y chromosome involved. In  $X2Y$  males with normal Y's or with one normal and one marked Y, the Y's disjoin almost twice as frequently as they do from trivalents with two identical Y's. Tetravalent segregation is almost entirely two by two, with no preference for any of the three types of disjunction.

An odd situation was reported by Tokunaga (1958) in substrains of *Aphiochaeta xanthina* Speiser. When a male of the substrain was crossed to individuals bearing 3rd chromosome genes of the original strains, the mutant genes for brown, and so on, behaved as if they were partially sex-linked in the following generations. On the other hand, when a female carrying the partially sex-linked genes on the X and Y chromosomes, Abrupt or Oecli chiari, was crossed to the male of the substrain the characters segregated as though they were autosomal. As a working hypothesis it was suggested that in this species the Y chromosome had the major male determining factors. The "special" male arose as a translocation of these factors to the third chromosome with the consequent change in linkage relations. Data on the role of the X chromosome in sex determination in this species have not yet been obtained but if they support the interpretation they indicate real differences between this species and that of

*Drosophila* in the location of the sex genes. The results are reminiscent of those obtained by Winge in *Lebistes* as well as those in *Melandrium* and other forms in which the Y or W chromosomes may contain strong sex genes for either sex. They would further support the thesis that sex genes may be distributed to almost any loci within the inheritance complex.

#### E. MATERNAL INFLUENCES ON SEX RATIO

Aside from chance and specific genetic factors, sex ratio is subject to effects from agents intrinsic in the cells of the mothers (Buzzati-Traverso, 1941; Magni, 1952). Strains of *Drosophila bifasciata* (Magni, 1952, 1953, 1957), *D. prosaltans* (Cavalcanti and Falcão, 1954), *D. willistoni* and *D. paulistorum* Spassky, 1956 have been isolated which were nearly all of the female sex even though the mothers were outbred to other strains having normal ratio bisexual progeny. Study of these strains by the above workers and Malogolowkin (1958) Malogolowkin and Poulson (1957), and Malogolowkin, Poulson and Wright (1959), as well as by Carson (1956) have shown inheritance strictly through the mother regardless of the genetic nature of the males to which they were bred. The unbalanced ratio was retained even when the original chromosomes had been replaced by homologous genomes from lines giving normal male and female progenies. Transmission of this unbalanced sex ratio was through the cytoplasm. Eggs fertilized by Y-bearing sperm died early in the course of development. Malogolowkin, Poulson and Wright (1959) have shown that the high female ratio and embryonic male deaths may be transferred from affected females to those which do not normally show the condition through injection of ooplasm from infected females. Ooplasm of this same type is, when injected into males, sufficient to cause death to occur within 3 days. In the females a latent period of 10 to 14 days after ooplasm injection was apparently necessary to establish egg sensitization. Once established the condition could be transmitted through the female line for several generations. The ooplasm injections were not as efficient in establishing these lines as females found naturally infected. Unisexual broods may

fail to appear, in some instances fail to transmit the condition or produce intermediate progeny ratios, as well as in some instances to skip a generation. The infectious agent was found to vary in different species. Magni (1953, 1954) for *D. bifasciata* found that temperature above normal tended to remove the cytoplasmic agent making it ineffective. This result has a parallel to the action of temperature on certain viruses, as for instance that involved in one of the peach tree diseases. On the other hand, Malogolowkin (1958) for *D. willistoni* found no temperature effect. Malogolowkin further found that the cytoplasmic factor was not independent of chromosomal genes since some wildtype mutant strains induced reversions to normal sex ratio. Recently Poulson has established the complete correlation of the high female progeny characteristic with the presence of a Treponema in the fly's lymph. As with mouse typhoid variations, lethality was genotype dependent.

These cases have interest from more than the sex ratio viewpoint. Cytoplasmically inherited susceptibility of some strains of *D. melanogaster* to poisoning by carbon dioxide as studied by L'Heritier (1951, 1955) depended on the presence of some cytoplasmic entity which passed through the egg cytoplasm and also, but less efficiently, by means of the male sex cells to the progeny. The carbon dioxide susceptibility was transmitted through injections of hemolymph or transplantation of organs of susceptible strains. The transmissible substance had a further property of heat susceptibility. The CO<sub>2</sub> susceptibility differed from that of "sex ratio" in being partially male transmitted. It agrees with "sex ratio" *D. bifasciata* in being heat susceptible but differs from *D. willistoni* "sex ratio" in this respect.

*D. bifasciata* may behave differently than *D. willistoni* in that Rasmussen (1957) and Moriwaki and Kitagawa (1957) both conducted transplantation experiments with negative results. However, it is possible that these experiments may be affected by a different incubation period for the injected material as contrasted with that for *D. willistoni*. A range of possibilities evidently exist for extrinsic effects in sex ratio.

Carson (1956) found a female producing strain of *D. borealis* Patterson, which car-

ried on for a period of 8 generations, produced 1327 females with no males. The strain showed no chromosomal abnormalities. It had 3 inversions. The females would not produce young unless mated to males from other strains having biparental inheritance. This requirement, together with gene evidence, showing that the females were of biparental origin, is against the female progenies being derived by thelytokous reproduction.

#### F. MALE-INFLUENCED TYPE OF FEMALE SEX RATIO

Sturtevant in 1925 described experiments with a stock of *D. affinis* in which a great deficiency of sons was obtained from certain males, regardless of the source of females to which such males were mated. The few males obtained from such matings were normal in behavior but some of the sons of females from such anomalous cultures again gave very few sons (Morgan, Bridges and Sturtevant, 1925).

Gershenson (1928) in a sampling of 19 females caught in nature found two that were heterozygous for a factor causing strong deviations toward females (96 per cent to 4 per cent males) whereas the normal *D. pseudoobscura* ratio was nearly 1 to 1. The factor was localized in the X chromosome and was transmitted like an ordinary sex-linked gene. Its effect was sex limited as it was not manifest in either heterozygous or homozygous females. It had no effect on the development of zygotes already formed but strongly influenced the mechanism of sex determination through the almost total removal of the spermatozoa with the Y chromosome from the fertilization process. Egg counts showed the divergent ratio toward females was not caused by death of the male zygotes inasmuch as there was no greater mortality from such cultures than from controls giving 1 to 1 sex ratios.

Sturtevant and Dobzhansky (1936) showed that an identical or nearly identical phenotype to that observed in *Drosophila obscura* was present in *D. pseudoobscura*. The *D. pseudoobscura* carrying the factor were scattered over rather wide geographical areas. Comparable types also were found in two other species *D. athabasca* and *D.*

*azteca*. This gene "sex ratio" *sr* lies in the right limb of the X of races A and B of *D. pseudoobscura*. Like the other cases analyzed, males carrying *sr* have mostly daughters and few sons regardless of the genotypes of their mates. Structurally the female sex ratio came through modification of the development of the sex cells of the male to give a majority of X-bearing sperm. Cytologic study showed that in "sex ratio" males the X underwent equational division at each meiotic division, whereas the autosomes behaved normally. The Y chromosome lagged on the first spindle, remained much condensed, and its spindle attachment end was not attenuated. The Y chromosome was not included in either telophase group of the first meiotic division but was left behind. It was sometimes noted in one of the daughter cells where it formed a small nucleus. Among 64 spermatocytes examined, all had an X chromosome and none a Y chromosome in their main nuclei. The micronuclei containing Y played no further part in the division, became smaller and exceedingly contracted. The final fate of the micronuclei was uncertain, but there was no indication that any spermatids died or were abnormal.

#### G. HIGH MALE SEX RATIO OF GENETIC ORIGIN

In 1920, Thompson described a recessive mutant in *D. melanogaster* which killed all homozygous females but changed the male phenotypes only slightly, the wings standing erect above the back. The locus of the mutant was 38 in the X chromosome. This mutant was a leader for a class in which the genes affect only one sex but are innocuous to the other.

Bobbed-lethal, a sex-linked gene found by Bridges, is a gene of this class but one in which the mechanism of protection to the other sex is known. It kills homozygous females but does not kill the males because of the wild type allele which the males have in their Y chromosomes. The presence of this bobbed-lethal in a population consequently leads to male ratios higher than wild type.

A recessive gene in chromosome II, discovered by Redfield (1926), caused the early death of the majority of female zygotes and led to a sex ratio of about 1 female to 5.5 males. The effect was trans-

mitted through both males and females. The missing females may have died largely in the egg stage although disproportionate losses also occurred in the larval and pupae. The maternal effect was attributed to an influence exerted by the chromosome constitution of the mother on the eggs before they left the mother's body. Because of this maternal lethal, the families from these mothers have the normal number of sons but few or no daughters.

A culture was observed by Gowen and Nelson (1942) which yielded only male progeny, 136 in all. Some of the male progeny were able to transmit the male-producing characteristics to half of their daughters without regard to the characteristics of the mates to which they were bred. The inheritance was without phenotypic effect on the males. When present in the heterozygous condition in females, the female's own phenotype gave no indication of the gene's presence. The inheritance was sex limited in that it affected only the eggs laid by the mothers carrying it. In these eggs it acted as a dominant lethal for the XX zygotes. The gene was found located in the 3rd chromosome between the marker genes for hairy and for Diebeate at approximately 31. The X eggs carrying the gene, *Xe*, died in the egg stage at between 10 and 15 hours under 25°C. temperature. The gene was as effective in triploids as in diploids. One dose of this gene in triploids caused them to have only male progeny and male type intersexes. The presence of this gene caused the elimination of any embryos with chromosomal capacities for initiating and developing the primary or secondary female sexual systems. Since the gene itself was heterozygous in the female the meiotic divisions of the eggs would cause the gene to pass into the polar bodies as often as to remain in the fertilization nucleus yet the lethal effects are found in all eggs. The antagonism was between the egg cytoplasm and the XX fusion products. Supernumerary sperm of the Y type were not sufficient to overcome the lethal effects. An XY fertilization nucleus was necessary for survival.

This case has parallel features with that observed by Sturtevant (1956) for a 3rd chromosome gene that destroys individuals bearing the first chromosome recessive gene

for prune. The gene responsible was found to be a dominant, prune killer, K-pn, which was located in the end of the 3rd chromosome at 104.5. Prune killer was without phenotypic effect so far as could be observed except that it acted as a killer for flies containing any known allele of prune. It was equally effective in either males or females, hemizygous or homozygous, for prune. The larvae died in the 2nd instar but no gross abnormalities were detected in the dying larvae. This case has interest for the Ne gene in that the killer gene occupies a locus in the 3rd chromosome although removed by about 70 units from Ne, and acts on a specific genotype, the prune genotype, whereas Ne acts on the specific XX genotype. The known base for action of the prune killer is genetically much narrower than that for the female killer, Ne, in that prune killer acts on an allele within a specific locus in the X chromosome, and Ne acts on a type coming as a product of the action of two whole sex chromosomes. It is, of course, conceivable that when ultimately traced each action may be dependent upon specific changes of particular chemical syntheses. The action of these genes is also of interest from another viewpoint.

In mice there is a phenotype caused by the homozygous condition of a recessive gene (Hollander and Gowen, 1959) which acts on its own specific dominant allelic type in its progeny so as to cause an increased number of deaths between birth and two weeks of age, as well as causing the long bones to break and the joints to show large swellings. The lethal nature of this interaction is not a product of the mother's milk nor does it show humoral effects such as those observed with erythroblastosis in the human. The interallelic interaction is sex limited in that it is confined to the mother and is without effect when the male has the same genotype.

## II. FEMALE-MALE SEX RATIO INTERACTIONS

A case in *D. affinis* involving the interaction of a "female sex ratio" factor and an autosomal "male sex ratio" factor has been studied by Novitski (1947). Starting from stock which had a genetic constitution for the "sex ratio" X chromosome which ordinarily causes males carrying it to produce

only daughters, he was able to establish a recessive gene in chromosome B in whose presence only male offspring resulted. The genetic constitution of the male was alone important. High sterility accompanied the "male sex ratio" males breeding performance. The "male sex ratio" parents yielded 95 fertile cultures having an average of 25 individuals per culture. Females appeared in 10 of these cultures with an average of 3 per culture for those producing females. The total sex ratio was 77 males per female. The males were morphologically normal. They carried an X chromosome of their mothers. Cytologic observation of spermatogonial metaphases of 3 progeny showed that the F<sub>1</sub> males may or may not have carried a Y of their fathers. This agreed with the tendency for sterility in these "male sex ratio" males. The ventral receptacles of the females from 4 such sterile cultures when examined proved devoid of sperm. The occasional female offspring of the "male sex ratio" males had one X chromosome from each parent. Females mated to "male sex ratio" males show large numbers of sperm in the ventral receptacles (7 out of 8 cases), although such females had usually produced no or very few offspring. The sperm, if capable of fertilization, must have had a lethal effect on the zygotes. The recessive nature of the factor in chromosome B indicated that its potential lethal effect originated during spermatogenesis rather than at the time of fertilization. This lethal period corresponds to that when the "female sex ratio" factor in the X chromosome is active.

The research on sex ratio in *Drosophila* reviewed shows that through the interplay of the sex chromosome-located and autosomal-located factors all types of sex ratios from only females in the family to only males in the family may be generated.

## V. Sex Determination in Other Insects

### A. SCIARA

Sciara, a fungus gnat, offers sex-determining mechanisms quite different from any yet offered in *Drosophila*. Sciara is unique, yet in its uniqueness, it illustrates basic facts that were rediscovered in other species only through the study of abnormal



forms some of which were created as induced developmental, chromosomal, or hormonal abnormalities. The complexities responsible for the remarkable facts were analyzed by Metz and his collaborators. The following brief review is based upon Metz's (1938) summarization of the chromosome behavior problem to which the reader is referred for further information. Of *Sciara* species studied 12 out of 14 have their basic chromosome groups composed of three types of chromosomes: autosomes, sex chromosomes, and "limited" chromosomes. Two species, *S. ocellaris* Comstock and *S. reynoldsi* Metz, lack the "limited" chromosomes. Two sets of autosomes and three sex chromosomes are found in the zygotes of all *Sciara* species at the completion of fertilization. The behavior of these chromosomal types will be considered in sequence.

The autosomes behave normally in somatic mitosis and in oogenesis. There is cytologic and genetic evidence for synapsis, crossing over, random segregation, and regular distribution of chromosomes and genes in the female.

In spermatogenesis the story is quite different. The first maturation division is unipolar. Genetic evidence shows a complete, selective segregation of the maternally derived autosomes and sex chromosomes from those of paternal origin. The paternal homologues move away from the pole, are extruded, and degenerate. The second spermatocyte division is likewise unequal and one of the products, a bud, degenerates. Thus a spermatogonial cell passing through meiosis gives rise to only one sperm. At the second spermatocyte division all of the chromosomes (maternal homologues) except the sex chromosome undergo an equational division but both halves of the sex chromosome enter into the same nucleus. This nucleus becomes the sperm nucleus. The chromosomes at the opposite pole form a bud and degenerate. Fertilization of the *Sciara* egg is normally monospermic not polyspermic.

The sex chromosomes XXX of the fertilization nucleus are derived, two from the sperm and one from the oocyte. Their destiny depends on whether the egg they are

in develops into a male or a female imago. In male early development, those nuclei which are to become male soma lose the two sex chromosomes XX, contributed by the father's sperm, to give  $X + 2A$  soma. These chromosomes fail to complete mitosis at the 7th or 8th cleavage division and are left to degenerate in the general cytoplasm when there are no true cells in the soma region and no membranes surround the nuclei. Those embryos which are to become female soma at the same cleavage cycle eliminate but one paternal X chromosome. On a chromosome basis the soma cells respectively become X, plus two sets of autosomes, give rise to males on differentiation, or become  $XX + 2A$  and develop female organs (Du Bois, 1932). The germ line nuclei for each sex, on the other hand, remain unrestricted in their development. They retain their XXX constitutions until the first day of larval life, or about 6 hours before the formation of the left and right gonads (Berry, 1941), when they eliminate a single paternally derived X. The X which is rejected or makes its own exit is always one of two sister chromosomes contributed by the father. The process of loss is strikingly different from that noted in the soma-building nuclei. Both cell walls and nuclear membranes are present. The path of the X chromosome is through the nuclear membrane into the cytoplasm where degeneration eventually takes place. The loss occurs at a time when there is no mitotic activity and the chromosomes are separated from the cytoplasm by an intact nuclear membrane.

Some *Sciara* species are characterized by females which produce only unisexual families—practically all females or practically all males. Genetically, the sex of progeny is accounted for by sex chromosomes,  $X'$  and X, which are so designated because of their physiologic properties. Mothers having only female progeny are characterized by always having the  $X'$  chromosome in all their cells,  $X'X + 2A$ , whereas mothers whose progeny are all males are  $XX + 2A$  (Moses and Metz, 1928). The all female and all male broods are observed in about equal numbers. The male has no influence on sex ratio. Normally the progeny in all female broods will be  $X'X + 2A$  or  $XX + 2A$  in soma

and germ lines, whereas the all male progeny broods will be only  $X + 2A$  in the soma and  $XX + 2A$  in the germ line.

Studies of Crouse (1943, 1960a, b) show nondisjunction may occur and eggs entirely lacking sex chromosomes or having double the normal number may be produced. When the nondisjunctional eggs lacking X chromosomes are from  $XX$  females and are fertilized by sperm contributing two sister X chromosomes, one X (as expected of  $XX$  mothers, not two as expected of  $XX$  cells) is eliminated at the 7th or 8th cleavage to give cells which develop into "exceptional" males with  $XO + 2A$  soma and  $XX + 2A$  germ line, all X chromosomes being of paternal origin. The casting out of the single X chromosome is consequently controlled by the characteristics of the egg cytoplasm derived from the  $X'X$  mother rather than by the kind of chromosomes present in the nuclei at the 7th or 8th cleavage stage of the embryo.

Similarly when nondisjunctional eggs having both XX chromosomes of the XX mothers are fertilized by the normal sperm-bearing XX chromosomes, the zygotes are XXXX. At the 7th or 8th cleavage both paternal X chromosomes are eliminated and the resulting soma develops into an "exceptional" female,  $XX + 2A$ , often with 3 X's in her germ line. These observations confirm the earlier interpretations that the  $X'X$  or  $XX$  constitution of the mother conditions her eggs respectively to cast out 1 or 2 parental X chromosomes at the 7th or 8th cleavage according to the cytoplasmic constitution of the egg. Somatic sex development is visually determined only after this stage when the chromosomes of the somatic cells take on the familiar aspect of either  $XX + 2A$  for the females or  $X + 2A$  for the males.

Although at present there are few examples in other species, this cytoplasmic conditioning of early embryologic development by the mother's genotype may be a common rather than a rare occurrence of development. The expression of the events to which this control may lead may be quite different in different cases. The spiral of snail shells was an early recognized case (Sturtevant, 1923). In *Drosophila*, a gene acting through the mother's genome allows only

male embryos to survive (Gowen and Nelson, 1942), suggesting that this gene acts through her cytoplasm in a manner comparable to that of the  $X'$  and X chromosomes of *Sciara*. In either case the genotype would not be considered a primary sex factor, profound as the effect on sex may ultimately be.

*Sciara* also has strains or species where the progeny of single matings are of both sexes, bisexual, yet the chromosomal elimination mechanisms remain as described above save for the fact that they now operate within broods rather than between broods. Sex ratios for the families within these bisexual strains are extremely variable, 1:0 or 0:1 ratios not being infrequent and 1:1 ratios being the exception. An instance of a bisexual strain arising from a unisexual line has been analyzed by Reynolds (1938). The females were found to be 3X in their germ line and produced 2X eggs which developed into daughters and X eggs which became sons. Loss of the extra X from this line resulted in the line's return to unisexual reproduction.

In general, bisexuality as contrasted with unisexuality seems to be caused by differences in the  $X'X$ -XX mechanisms, either specific for the mechanism, or induced by modifying genes which cause different embryos within the same progeny to cast out sometimes one or sometimes two X chromosomes from all their somatic nuclei. This casting out occurs uniformly for all nuclei of a given embryo as is shown by the fact that sex mosaics or gynandromorphs are as seldom observed in bisexual as unisexual strains.

Some species of *Sciara* have large chromosomes which are in essence "limited" to the germ line since they are lost from the somatic nuclei at the 5th or 6th cleavage division. Other species lack these chromosomes, yet agree with the rest in the behavior of their remaining chromosomes and in sex determination. So far as is now known the "limited" chromosomes seem empty of inheritance factors influencing either sex or unisexual *vs.* bisexual broods or for that matter other characteristics (their persistence seems to make this latter unlikely). Their presence does lead to a question of the efficiency of desoxyribonucleic acid

(DNA) as the all inclusive agent in inheritance for they are clearly DNA-positive.

These cytogenetic observations clear up most of the events leading to sex differentiation and the delayed time in embryologic development when it takes place, but, as Metz points out, other puzzling questions are raised. Observed chromosome extrusions from cell nuclei are rarities today even though discovered for *Ascaris* 60 years ago. Why should this mechanism be so well defined in *Sciara*? Why should the mode of elimination be so accurately timed and yet be different in method and time for the soma and germ cell lines? Two of the three X chromosomes in the fertilized egg are sisters from the father and should be identical. What is special in the 7th or 8th cleavage that causes elimination in the soma plasm but not in the germ plasm? Why should the casting out of one of these same paternal X's in the germ plasm of both sexes be reserved for a much later stage in cleavage and by a different procedure?

The observations of Crouse (1943, 1960a), obtained from translocations and species crosses, are critical in showing that the chromosome first moving in its entirety to the first differentiating pole of the second spermatocyte division is the X and is the one taking part in the later postfertilization sex chromosome elimination of the 7th or 8th cleavage. The X heterochromatic end of the chromosome and not the centomere region seems to be responsible for the unique behavior of this chromosome (Crouse, 1960b). Induced nondisjunctional eggs of X'X (female-producing) mothers having as a consequence no sex chromosomes, when fertilized by the normal sperm bringing in XX chromosomes, develop into embryos eliminating one of these X's at the 7th or 8th cleavage, as expected of the eggs of X'X mothers, and become "exceptional" males with X + 2A soma and XX paternal germ line. Imagoes of these embryos become functional but partially sterile males transmitting the paternal X, a reversal of the normal condition. Similarly the nondisjunctional eggs retaining both X's, XX from male-producing mothers, and having 4 X's on fertilization eliminate the two paternal X's, as occurs normally in XXX embryos, to become "exceptional" females with

2X or sometimes in species hybrids 3X soma.

Phenotypic sex in *Sciara* on this evidence depends on the adjustment of the X chromosome numbers and their contained genes with this adjustment regularly taking place, not at fertilization as in most forms like *Drosophila*, but at the 7th or 8th cell cleavage of embryologic development. The X' vs. X chromosomes of the mother predispose her haploid egg cytoplasm to time specific chromosome elimination. The germ line cells on the other hand may regularly have other chromosome numbers than the soma or exceptionally tolerate other numbers as extra X's (Crouse, 1943), or extra sets (Metz, 1959).

Triploids of 3X and 3A soma have not been found in pure *Sciara* species. Salivary gland cells of a triploid hybrid *S. ocellaris* x *S. reynoldsi* have two sets of *S. ocellaris* and one of *S. reynoldsi* chromosomes (Metz, 1959). Chromosome banding in 2X + 3A, 3X + 3A larval glands showed the *S. ocellaris* homologues were heterozygous. The 3X + 3A type chromosomes were of typical female appearance. The 2X:3A-type had X chromosomes of typical male type, very thick, pale and diffuse. The mosaic salivaries were a mixture of the two types of cells. These results suggest that the 3X:3A would be a typical female. The intersexes 2X + 3A conceivably have a range in male and female organ development depending on how the *S. ocellaris* and *S. reynoldsi* chromosomes act. If the chromosomes are equivalent, the gene expression would be expected to be that of a 2X to 3A or a phenotypic intersex. If they act separately the *S. ocellaris* genes would be in balance for female determination, whereas the *S. reynoldsi* autosomal genes would have no X *S. reynoldsi* genes to balance them and presumably would be overwhelmingly male in effect. The phenotypic outcome would be in doubt.

The maternally governed cleavage and chromosomal sequence occurring before the 8th embryonic cell division, although related to the subsequent events leading to the particular sex, is unique to *Sciara* and its relatives. Phenotypic sex expression apparently starts with the somatic nuclei having either X + 2A or XX + 2A as their chro-

mosomal constitutions. *Sciara* is like *Drosophila* and many other genera in its basic sex-determining mechanism. There is a sex-indifferent period when the maternal genotype may influence development through cytoplasmic substances. This is followed by active differentiation when the sex phenotypes may be influenced by various agencies but when passed becomes fixed for phenotypic sex. The indifferent period may represent a fairly large number of early cell generations as in amphibia or fish. Somatic and germ cells are labile but are normally susceptible to control only by forces developed within the organism as present knowledge indicates for *Sciara*. In *Sciara*, only the somatic cells conform in chromosome number to their expected phenotypes. The germ cells show not only a regulated instability of their chromosome number but the number is different from that of the supporting somatic cells. The fact that sex mosaics in *Sciara* may develop both an ovary and testis in the same animal (Metz, 1938; Crouse, 1960a, b) shows localized phenotypic sex determination occurring fairly late in development rather than the generalized determination that would occur if sex were established at fertilization.

The germ line chromosomal differentiation from that of the somatic tissue has parallels in a number of fairly widely dispersed species. The significance of these types to soma line determination and to the reversibility or irreversibility of differential gene activation in differentiated cells subsequent to embryogenesis has been considered by Beermann (1956). Although these types are yet in the fringe areas of our knowledge surrounding the general paths taken in the evolution of sex determining mechanisms, they promise to have more generality as clarification of gene action becomes more exact.

#### B. *APIS* AND *HABROBRACON*

Hymenopteran interpretations of sex determination have largely turned on studies of the honey bee, *Apis mellifera* Linnaeus and *Habrobracon juglandis* Ashmead. Dzierzon early established that the drones of honey bees come from unfertilized eggs, whereas the females, queens, and workers come from fertilized eggs so that sex differ-

entiation is marked by an  $X$  set of chromosomes for the male and  $2X$  for the female. This mechanism was satisfactory until it was realized that on a balanced theory the doubling of a set of chromosomes, if truly identical, should not change the gene balance and consequently not the sex. Further doubt was cast on the  $X-2X$  hypothesis for sex determination by the discovery of diploid males by Whiting and Whiting (1925). These difficulties were resolved by Whiting (1933a, b) with the suggestion that the two genomes in the female were not truly alike but actually contained a sex locus linked with the gene for fused which was occupied by different sex alleles as  $X_a$  and  $X_b$ . In this view the heterozygous condition would lead to the production of females, whereas in the haploid or homozygous condition either of these genes would react to produce males. Difficulties with this hypothesis became evident in that the ratios of males to females in certain crosses were significantly divergent from those which were expected. Evidence was collected and trials made to interpret these difficulties (Whiting, 1943a, b) by assuming that on fertilization by  $X_a$ -bearing sperm the polar body spindle would turn so as to cast out the  $X_a$  chromosome and retain the complementary  $X_b$  in the majority of cases instead of in a random half. Snell (1935) offered the hypothesis that there could be several loci for sex genes, such that the  $X$  locus might be a master locus, but when this locus was in homozygous condition the sex would then be controlled by genes in other loci in the genome. As pointed out by Bridges (1939) this hypothesis would satisfy that of sex gene balances postulated in *Drosophila* and of change in emphasis on loci for sex genes as observed by Winge (1934) in *Lebistes*. However, the work of Bostian (1939) called both hypotheses into question. Consideration of these further results led to the multiple allele hypothesis of complementary sex determination for *Habrobracon* (Whiting, 1943a) taking a similar form to that of the sterility relations observed for a single locus in the white clover of *Melilotus*. Under this system the sex locus would be occupied by multiple alleles, any one of which or any combination of identical alleles would be male-producing, but any combination of two different al-

les would be female determining. By having a sufficient number of these genes the production of diploid males would be curtailed to a point at which their various frequencies could be explained. In support of this hypothesis, multiple alleles to the number of at least 9 were found to exist for this single sex locus.

In principle at least, the honey bee could have the *Habrobracon* scheme of sex determination. Rothenbuhler (1958) has recently collected the researches which test this possibility. Tests of the multiple allele hypothesis as applied to the honey bee were made by Mackensen (1951, 1955) who interpreted evidence for inviable progeny produced by mating of closely related individuals as proof that this species as well as *Habrobracon juglandis* follows the multiple allelic system. The discovery of male tissue of biparental origin in mosaic bees from related parents was considered as further evidence for the multiple allelic theory of sex determination (Rothenbuhler, 1957).

Most recent cytologic evidence supports the concept that there are 16 chromosomes in the gonadal cells of the male and 32 in those of the female (Sanderson and Hall, 1948, 1951; Ris and Kerr, 1952; Hachimohe and Onishi, 1952; Wolf, 1960). Hachimohe and Onishi (1952) found 16 chromosomes as characteristic of the meiosis in the drone. Wolf observed a nucleus in both bud and spermatocyte of the only maturation (equational) division.

The greatest progress has been made in understanding the mechanisms of sex mosaicism in the Hymenoptera species. These mosaics, although ordinarily of rather rare occurrence, have a direct bearing on sex determination and development. In *Apis*, polyspermy furnishes the customary basis for their formation. One sperm fertilizes the haploid egg nucleus and another sperm, which has entered the egg instead of degenerating as it ordinarily does, enters into mitotic cleavage and eventually forms islands of haploid cells of paternal origin among the diploid cells derived from the fertilized egg (Rothenbuhler, Gowen and Park, 1952). Evidence showing that genetic influences affect the sperm nucleus toward stimulating its independent cleavage is found to exist in *Apis* material (Rothen-

buhler, 1955, 1958). Thousands of gynandromorphs have been observed in *Apis*, all but a small number of which have been produced in this manner. This method of initiating sex mosaics also exists for *Habrobracon* (Whiting, 1943b) but is rather rare. In *Habrobracon* the frequent mode has a different origin. The gynandromorph is formed from the cleavage products of the normal fertilization of the egg nucleus combined with those of a remaining nuclear product of oogonial meiosis. Under these conditions the female tissue is  $2N$  of biparental origin and the male tissue is  $N$  of maternal origin (Whiting, 1935, 1943b). This type is less frequent in *Apis* but one specimen has been described by Mackensen (1951).

A number of other ways in which sex mosaics may occur are occasionally expressed in these species. Three different kinds of male tissue have been observed in individual honey bee mosaics produced by doubly mated queens—haploid male tissue from one father, haploid male tissue from the other genetically different father, and diploid male tissue of maternal-paternal origin. In other cases, the diploid, biparental tissue was female and associated with two kinds of male tissue (Rothenbuhler, 1957, 1958). Cases where the haploid portions of the sex mosaics are of two different origins, one paternal and the other maternal, while the female portion is representative of the fertilized egg, are known in *Habrobracon* (Whiting, 1943b). Similarly, Taber (1955) observed females which were mosaics for two genetically different tissues and which he accounted for as the result of binucleate eggs fertilized by two sperm. Mosaic drones of yet another type were observed by Tucker (1958) as progeny of unmated queens. They were interpreted as the cleavage products from two of the separate nuclei formed in meiosis. These cases represent a number of the possible types that arise through meiotic or cleavage disfunctions under particular environmental or hereditary conditions.

Tucker (1958) studied the method by which impaternal workers were formed from the eggs of unmated queens. For this purpose he used genetic markers, red, chartreuse, ivory, and cordovan. Observations

were made on 237 workers from heterozygous mothers. For the chartreuse locus, 12 to 20 per cent were homozygous, for the ivory locus 1.8 per cent, and the cordovan locus on lesser numbers 0 per cent. An egg which is destined to become an automictic worker, a gynandromorph with somatic male tissue or a mosaic male, is retained within the queen for an unusually long time during which meiosis is suspended in anaphase I. Normal reorientation of first division spindle is possibly inhibited by this aging so that after the egg is laid meiosis II occurs with two second division spindles on separate axes as Goldschmidt conjectured for rarely fertile rudimentary *Drosophila* (1957). Two polar bodies and two egg pronuclei are formed. The polar bodies take no further part in development. In most of the unusual eggs the two egg pronuclei unite to form a diploid cleavage nucleus which develops into a female. Rarely the two egg pronuclei develop separately as two haploid cleavage nuclei to form a mosaic male. Two unlike haploid cleavage nuclei, one descending from each of the two secondary oocytes after at least one cleavage division, unite to form a diploid cleavage nucleus which develops together with the remainder of the haploid cleavage nuclei to produce a gynandromorph with mosaic male tissues. The male and female tissues within these unusual gynandromorphs or female types were identical with normal drone or normal female tissues so were probably haploid and diploid respectively. Genetic segregation observed within the mothers of automictic workers allows the estimation of the distance between the locus of the gene and its centromere. With random recombination and "central union" Tucker estimates this distance for the chartreuse locus to centromere as 28.8 units and for the ivory to its centromere 3.6 units. Four lines of bees of diverse origin all showed a low percentage of automictic or gynandromorphic types produced from queens in each line. Various chance environmental conditions apparently influence the rate of production of these types. However, there were some females in two of the lines with higher frequencies indicating that innate factors may have significant effects on their frequencies. Observations on *Drosophila* spe-

cies—*D. parthenogenetica* (Stalker, 1956b), *D. mangabeirai* (Murdy and Carson, 1959) and *D. melanogaster* (Goldschmidt, 1957)—strongly support this view.

The problem of sex determination in *Habrobracon* presently stands as a function of multiple alleles in one locus, the heterozygotes being female and the azygotes and homozygotes male. The occasionally diploid males are regularly produced from fertilized eggs in two allele crosses after inbreeding. These diploid males are of low viability and are nearly sterile. Their few daughters are triploids, their sperm being diploid. Apis probably follows the same scheme, as a few cases of mosaics with diploid male tissue are known and close inbreeding results in a sufficient number of deaths in the egg to account for diploid males which might be formed. *Mormoniella* (Whiting, 1958), however, shows that this scheme for sex determination does not hold for all Hymenoptera. In this form diploid males may occur through some form of mutation. They may then develop from unfertilized eggs laid by triploid females. In contrast to *Habrobracon* the diploid males are highly viable and fertile. Their sperm are diploid and their numerous daughters triploid. Virgin triploid females produce 6 kinds of males, 3 haploid and 3 diploid. Similarly *Melittobia* has still a different and as yet unexplained form of sex determination. Haploid eggs develop into males. After mating many eggs are laid which develop into nearly 97+ per cent females. The method of reproduction is close inbreeding but no diploid males or "bad" eggs are formed. The problem of the sex determining mechanism remains open (Schmieder and Whiting, 1947).

#### C. BOMBYX

The silkworm, *Bombyx mori*, differs from *Drosophila*, *Lymantria* and the species thus far discussed in having a single region in the W chromosome (Hachimoto, 1933; Tazima, 1941, 1952) occupied by a factor or factors of high female potency. The strong female potency has thus far been common to all races. The chromosome patterns of the sexes are like those of *Abraxas* and *Lymantria*; males ZZ + 2A and females ZW + 2A. The diploid chromosome number is 56 in both sexes. Extensive, well executed studies

have revealed no W chromosome loci for genes expressed as morphologic traits. From radiation-treated material it has been possible to pick up a translocation of chromosome II to the W chromosome as well as a cross-over from chromosome Z. This chromosome together with tests of hypoploids and hyperploids have materially aided in understanding how the normal chromosome complexes determine sex. The sex types resulting from different chromosome arrangements have been summarized by Yokoyama (1959) and are presented in Table 1.3.

Whenever the W chromosome was absent a male resulted. Extra Z or A chromosomes did not influence the result. Similarly with a W chromosome in the fertilized egg a female developed. Again extra Z or A chromosomes did not influence the result.

A full Z chromosome was essential to survival. Hypoploids deficient for different amounts of the Z chromosome in the presence of a normal W chromosome all died without regard to the portion deleted. Hyperploids for the Z chromosome, on the other hand, when accompanied with a W chromosome all lived and showed no abnormal sexual characteristics. Parthenogenesis led to the production of both sexes, although the males were more numerous than the females. Diploidy was necessary for the embryo to go beyond the blastoderm stage. Triploid and tetraploid cells were often found. High temperature treatments led to merogony (Hasimoto, 1929, 1934). The exceptional males were homozygous for a sex-linked recessive gene and were explained by assuming that the egg nuclei were inactivated by the high temperature and the exceptional males developed from the union of two sperm nuclei. This conclusion was supported by cytologically observed polyspermy (Kawaguchi, 1928) and by cytologic observation of the union of two sperm nuclei by Sato (1942). Binucleate eggs were also believed to occur, which when fertilized by different sperm may each construct half of the future body. This type of mosaicism was influenced by heredity (Goldschmidt and Katsuki, 1927, 1928, 1931). Polar body fertilization was also believed to occur, one side of the embryo originating from the ordinary fertilized egg nucleus and the other side from the union of

TABLE 1.3  
*Sex in Bombyx mori*  
(Summarized by T. Yokoyama, 1959.)

Sex	Chromosome Types and Numbers		
	W	Z	A
Male		ZZ	AA
Male		ZZ	AAA
Male		ZZZ	AAA
Female	W	Z	AA
Female	W.W.Z <sup>1</sup>	Z	AA
Female	W	ZZ	AAA
Female	W	ZZZ	AAAA
Female	WW	ZZ	AAA
Female	WW	ZZ	AAAA

nuclei of two of the polar bodies. Similarly, dispermic merogony was noted following the formation of one part of the body from the fertilization nucleus, the other part from the union of two sperm nuclei, the result being a gynandromorph or mosaic.

## VI. Sex Determination in Dioecious Plants

### A. MELANDRUM (LYCHNIS)

Over the last 20 years studies on several species of dioecious plants have made notable advances in understanding the mechanisms by which sex is determined.

*Melandrium album* has been shown to have the same chromosome arrangement as *Drosophila*. The male has an X and Y plus 22 autosomes, whereas the female has XX plus 22 autosomes. Sex-linked inheritance is known for genes borne in the X chromosomes as well as for genes born in the Y chromosome. The X and Y chromosomes are larger than any of the autosomes with the Y chromosome about 1.6 times that of the X in the materials studied by Warnke (1946). Separate male and female plants are characteristic of the species. By use of colchicine and other methods, Warnke and Blakeslee (1939), Warnke (1946), and Westergaard (1940) have made various polyploid types from which they could derive other new X, Y and A chromosome combinations from which information was obtained on the location of the sex determining elements. The Y chromosome carries the male determining elements, the X chro-

mosome the female determining elements. The guiding force of the elements in the Y chromosome during development is sufficient to override the female tendencies of several X chromosomes. Data derived by each of these investigators are shown in Table 1.4.

From these data Warnke (1946) concluded that the balances between the X and the Y chromosomes essentially determined sex with the autosomes of relatively little importance. Where no Y chromosomes were present but the numbers of X chromosomes ranged from 1 to 5, only females were observed, even though the autosomes varied in number from two to four sets. When a Y chromosome was present the individual was of the male type unless the Y was balanced by at least 3 X chromosomes when an occasional hermaphroditic blossom was formed.

TABLE 1.4

*Numbers of X, Y, chromosomes and A, autosome sets and the sex of the various Melandrium plants (Data from H. E. Warnke, 1946; and M. Westergaard, 1953.)*

Chromosome Constitution	Warnke	Ratio	
		X:A	Westergaard
4A 5X	Female	1.3	
4A 4X	Female	1.0	Female
4A 3X	Female	0.8	
4A 2X	Female	0.5	
3A 3X	Female	1.0	Female
3A 2X	Female	0.7	Female
2A 3X	Female	1.5	
2A 2X	Female	1.0	Female
		X:Y	
4A 4X Y	Bisexual†	4.0	Male
4A 3X Y	Male†	3.0	Male
4A 2X Y	Male†	2.0	Male
4A X Y	Male	1.0	
3A 3X Y	Male†	3.0	
3A 2X Y	Male†	2.0	Male
3A X Y	Male	1.0	
2A 2X Y	Male†	2.0	
2A X Y	Male	1.0	Male
4A 4X YY	Male†	2.0	
4A 3X YY	Male	1.5	
4A 2X YY	Male	1.0	Male
2A X YY	Male	0.5	

\* Occasional staminate but never carpellate blossom.

† Occasional hermaphroditic blossom.

When 4 X chromosomes were present together with a Y, the plants were hermaphroditic but occasionally had a male blossom. Two Y chromosomes almost doubled the male effect. Two Y chromosomes balanced 4 X chromosomes to give a majority of male plants. Only an occasional plant showed an hermaphroditic blossom. Autosomal sex effects, if present, were only observed when plants had 4 sets and 3 or 4 X chromosomes balanced by a Y chromosome. Warnke used the ratio of the numbers of X to Y chromosomes as a scale against which to measure changes from complete male to hermaphroditic types. No mention is made of quantitative measures of the sex character changes with increasing X chromosome dosages. This is of interest since in many forms changes in chromosome balance are accompanied by changes of phenotype which are unrelated to sex. That such phenotypic changes do accompany changes in autosomal balance in *Melandrium* are proven, however, by further observations of Warnke in 4 trisomic types coming from crosses of triploids by diploids. Of 36 such trisomics analyzed, 5 or 6 of them were of different growth habits and morphologic types. These differences did not affect the sex patterns since all were females. Warnke and Blakeslee in 1940 observed an almost complete array of chromosome types from 25 to 48 in progeny derived from crosses of 3N x 3N, 4N x 3N, and 3N x 4N. Out of about 200 plants studied, only 4 were found to show indications of hermaphroditism. These types were 2XY and 3XY. As noted from the table, even the euploid plants would occasionally be expected to have an hermaphroditic blossom. Of the 200 plants, all with a Y (XY, 2XY, 3XY) were males and all plants without the Y (2X, 3X, 4X) were females. In an 8-year period up to 1946, Warnke was able to observe only one male trisomic. From these facts he concluded that the autosomes are unimportant in the sex determining mechanism utilized by this species. In their crosses they were unsuccessful in getting a 5XY plant, the point at which the female factor influence of the X chromosomes might be expected to nearly equal or slightly surpass that of the single Y. From the physiologic side the observa-



tion of Strassburger in 1900, as quoted by both Warmke and Westergaard, that the fungus *Ustilago violacea* when it infects *Melandrium* will cause diseased plants to produce mature blossoms with well developed stamens (filled with fungus spores) as well as fertile pistils, shows that these females have the potentialities of both male and female development. The case suggests that sex hormone-like substances may be produced by the fungus which acting on the developing *Melandrium* sex structures cause sex reversions. Should this be true, *Melandrium* cells would have a parallel with those of fish where sex hormones incorporated in the developing organism in sufficient quantities can cause the soma to develop a phenotype opposite to that expected of their chromosomal type. For other aspects see Burn's chapter and Young's chapter on hormones.

Westergaard's studies (1940) with European strains of *Melandrium* were in progress at the same time as those of Warmke and Blakeslee. In their broad aspects both sets of data are concordant in showing the primary role of elements found within the Y chromosome in determining the male sex and of elements in the X chromosomes for the female sex. Examination of Table 1.4 shows that the strain used by Westergaard has a Y chromosome containing elements of greater male sex potentialities than the strain used by Warmke.

A similar difference appeared in the sex potencies of the autosomes of European strains. Instead of obtaining essentially only male and female plants in crosses involving aneuploid types, Westergaard obtained from 3N females (3A + 3X) x 3N males (3A + 2XY) 10 plants which were more or less hermaphroditic, 21 females, and 15 males. Studies of the offspring of these hermaphrodites through several generations showed that their sex expression required effects by both the X chromosomes and certain autosome combinations which under special conditions counterbalanced the female suppressor in the Y chromosome. Increasing the X chromosomes from 1 to 4 increased the hermaphrodites from 0 to 100 per cent in the presence of a Y chromosome. However, in euploids these types would be

all males. The significance of the autosomes is further shown by the fact that among 205 aneuploid 3XY plants, 72 were males and 133 were hermaphrodites.

As pointed out for *Drosophila*, quantitative studies on the effects of sex chromosomes and autosomes in *Melandrium* are handicapped by not having a suitable scale for the evaluation of the different sex types. The data presented by Westergaard and by Warmke make this difficulty become particularly evident. In the interest of quantizing the X, Y, and A chromosome on sex the author has assigned a value of 1 for the male type, 3 for the female type, and 2 when the types are said to be hermaphroditic. When the types are mixed, as for example, in the data of Warmke where he says a particular type is male with a few blossoms, the type is assigned a value of 1.05 or 1.10, depending on the numbers of these blossoms. His bisexual type which comes as a consequence of Y, 4X and 4A chromosome arrangement is given a value of 2, although possibly the value should be somewhat higher as it may well be that the fully bisexuals are further along in the scale toward female development than the hermaphroditic types. The data are treated on the additive scale both as between chromosomal types and within chromosomal type. This is apparently unfair if we examine the work of Westergaard in which it looks as if particular autosomes rather than autosomes in general make a contribution to sex determination. The results, when these methods are used, are as follows:

Westergaard in Tables 1 to 5 of his 1948 paper gives information on sex types with a determination of the numbers of their different kinds of chromosomes. Analysis of these data by least square methods shows that the sex type may be predicted from the equation

$$\text{Sex type} = -1.37 Y + 0.10 X \\ + 0.01 A + 2.34$$

This equation fits the data fairly well considering that the correlation between the variables and the sex type is 0.87. This analysis again shows that the Y chromosome has a strong effect toward maleness. The X chromosomes are next in importance

with an effect of each X only about 1.13 that of the Y and in the direction of femaleness, the autosomes have one tenth the effect of the X chromosomes but they too have a composite effect toward femaleness. It is to be remembered that the Y chromosome variation is limited to 2 chromosomes whereas the X chromosomes may total 4, and the autosomes may range from 22 up to 42, so that the total effect of the autosomes is definitely more than their single effects. These data are for aneuploids. Examining Westergaard's data for 1953 for the euploids and assigning the value of 1.5 for the type observed when there was one Y chromosome, four X, and four sets of autosomes, we have the following equation:

$$\text{Sex value} = -1.29 Y + 0.10 X - 0.01 \\ (\text{autosome sets}) + 2.53$$

In these data, as distinct from those above, the autosomes are treated as sets of autosomes since they are direct multiples of each other so the value of the individual autosome is but 1.11 that given in the equation.

This equation shows no pronounced difference from that when the aneuploids were utilized. The Y chromosomes have slightly less effect toward the male side. The X chromosomes have practically identical effects but there has been a shift in direction of the autosomal effects on sex, although the value is small. The constants are subject to fairly large variations arising through chance.

In Table 10 of Westergaard's 1948 paper he presented data on the chromosome constitution and sex in the aneuploids which carried a Y chromosome. These data are of particular interest as the plants are counted for the proportions of those which are male to those which are hermaphroditic. The plants with a Y chromosome plus an X are all males. Those which have either one, two or three Y chromosomes balanced by two X chromosomes have 89 per cent males. The plants with three X chromosomes and one or two Y's have 36 per cent males and those which have one or two Y chromosomes and four X chromosomes have no males. The work involved in getting these data is, of course, large indeed and is definitely handicapped by the difficulties in obtaining

certain types. Thus the XXYYY and the 4X + 2Y types depend only on one plant. There are eight observations but the fitting of the data for the X and Y constitutions eliminates three degrees of freedom from that number so that statistically the observations are few. The data do have the advantage that the sex differences can be measured on an independent quantitative scale. The equation coming from the results is:

$$\text{Percentage of males} = 13.2 Y - 36.4 X \\ + 134.4$$

These results show that the Y chromosome increases the proportion of males and the X chromosome increases the proportion of intersexes. The data are not comparable with those analyzed earlier as these data are describing simply the ratio between the males and intersexes, instead of the relations between the males, intersexes, and females. The equation fits the observations rather well, as indicated by the fact that the correlation between the X's and Y's and the percentages of males is 0.98, but there are large uncertainties.

As a contrast to these data we have those presented by Warmke (1946) in his Tables 2 and 3. These data give the numbers of X and Y chromosomes found within the plants but not the numbers of autosomes, the autosomes being considered as 2, 3, and 4 genomes. Analyzing these data in the same manner as those of Westergaard's Table 1, we find that the

$$\text{Sex type} = -1.05 Y + 0.22 X - 0.04 A \\ + 2.25$$

As indicated for Westergaard's data, the A effect is now in terms of the diploid type equaling 2, the triploid 3, and the tetraploid 4.

The Y chromosome has a pronounced effect toward maleness, the effect being somewhat less in Warmke's data than that of Westergaard's. The X chromosomes on the other hand, have nearly twice the female influence in Warmke's data that they do in the plants grown by Westergaard. A difference in sign exists for the effect of the A chromosome genomes as well as a difference in the quantitative effect. The values for

both sets of data are small and toward the male side. As Westergaard points out, the strains used by these investigators are of different geographic origins. The evolutionary history of the two strains may have a bearing on the lesser Y and greater X effects on the sex of the American types. Chromosome changes seem to have occurred in the strains before the studies of Warmke and Westergaard and will be discussed.

The location of the sex determiners has been studied by both investigators utilizing techniques by which the Y chromosome becomes broken at different places. These breakages may occur naturally and at fairly high rates in individuals which are  $Y + 2X + 2A$ . These facts suggest that the breakage of the Y chromosome occurs in meiosis since the breakage comes in selfed individuals of highly inbred stocks where heterozygosity is not to be expected, in the Y chromosome which has no homologue thus does not synapse, and in the second meiotic division. Plants showing these initial breakages seem to have the same constitution in all of the somatic cells of different organs as well as in the germ cells, again pointing to meiosis as the time of breakage.

In Warmke, Davidson and LeClerc's (1945) material, the normal offspring which resulted from selfing  $2A, 2XY$  plants, were  $2A, 2XY$  (male hermaphrodites),  $2A, 2X$  (female),  $2A, XY$  (male), and  $2A, X2Y$  (supermales), and in addition two abnormal hermaphroditic classes. These were: (1) a type in which the female structures were highly developed, essentially as well developed as in  $2A, 2X$  females and with normal stamens; and (2) a type in which there was a complete failure of stamen development shortly after meiosis. Cytologic examination showed these types to be associated with the Y chromosome breaks. The first type occurred when the homologous (synaptic) arm of the Y was deficient. The deficiencies ranged in size from a short terminal loss to one which seemed to include the entire, or nearly entire, homologous arm. It was of importance that the degree of abnormality was not proportional to the length of the deficiency. Once a small terminal segment was lost the change in sex type occurred and larger

losses seemed to have no more pronounced effect. Chromosomes of this type showed complete asynapsis of the Y chromosome, indicating that its synaptic element comparable with the X was lost. Loss of as much as one-fifth to one-fourth of the arm prevented synapsis. These results seemed to indicate that the Y chromosomes had lost elements which acted as suppressors to the female development.

The second type observed by Warmke was associated with a break in the differential arm of the Y chromosome. A small terminal loss of this differential arm was sufficient to cause male development to be arrested and sterility to result. The plants that had lost as little as one-fourth the differential arm were therefore male sterile and were also indistinguishable from plants that had lost both arms. The altered X chromosomes retained their centromeres and were carried through mitotic growth divisions to every cell of the plant. Only in rare cases, and with very small fragments, was there evidence that somatic loss may have occurred. From these results Warmke concluded that the Y chromosome contained at least three gene complexes which operated in the development of maleness. First there was one near the centromere and present in the smallest fragment of the Y chromosome which initiated male development. The stamens developed but only just past meiosis. The second factor was found near the end of the differential arm of the Y chromosome and influenced complete male development. When the entire differential arm of the Y chromosome was present, full male development resulted. The third element appeared on the terminal fourth of the homologous arm of the Y chromosome and suppressed female development. Whether this was in the pairing segment or close to it was uncertain. In individuals with entire Y chromosomes, plus two X chromosomes, the female structures were underdeveloped with only a small percentage of the blossoms capable of setting capsules with seed. When the homologous arm was deficient the female development was complete and every blossom produced seed-filled capsules, again supporting the conclusion that this part of

the Y chromosome acted as a positive suppressor of female determining regions in the X chromosomes. That these regions were strictly located and the effect not due to the quantities of the Y chromosome which may have been present or absent was indicated by crosses of the different types of fragments. In these crosses the resulting total Y chromatin may have been considerably greater in size than a normal single Y chromosome, yet the observed changes in sex characteristics of the specific regions lost were present. The results indicated that the sex elements located in the Y chromosomes were qualitatively distinct from one another in their action and cannot be substituted for another in quantitative fashion. The causes of the differential changes in each case could rest on single gene differences or possibly a closely associated nest of such genes.

Westergaard's studies showed that his plants behaved differently in some particulars from those of Warmke. His search for the male determining elements in the Y chromosome of his Danish plants emphasized these differences. He was able (1946a, b) to divide the Y chromosome into four different regions, a region corresponding to the X chromosome in which there was synapsis and three regions containing various sex initiating elements. When these elements were compared with those of Warmke's it was found that they were comparable in action but differed in their order within the Y chromosomes. The Danish plants had the female suppressor region in the end opposite the pairing region at the extremity of the differential region. The elements initiating anther development were found near the centromere, but toward the pairing region. The element which completed development was found near the pairing region or homologous section. When compared with Warmke's results the position of the different elements in the Westergaard material was the reverse of that in the American material. Westergaard explained this difference on the assumption of a centric inversion in the Y chromosome resulting in the change of positions. As he suggested, it would certainly be interesting to know the geographic distribution of

these two types and what would result in progeny of crosses between them.

Westergaard (1948) summarized his views on the sex-determining mechanism in Melandrium as follows. A trigger mechanism is built up by an absolute linkage between the female suppressor region and at least two blocks of essential male genes in the Y chromosome. This trigger mechanism operates with the X chromosomes and autosomes in which the X chromosomes have female potencies and certainly the autosomes contribute to them. The action of these two types can only be demonstrated through the breaking of the normal balance by polyploidy or aneuploidy. As yet, the female potentials of the X chromosome and certain of the autosomes have not been analyzed to the extent of showing whether they contain major female sex genes or flocks of modifying genes. Westergaard favors the hypothesis of modifying genes.

#### B. RUMEX

Rumex studies on sex determination took their origin as with most dioecious plants in chromosome examinations of the different members of this genus (Kihara and Ono, 1923; Kihara, 1925; Ono, 1930, 1935; Kihara and Yamamoto, 1935). These studies showed that the species *Rumex acetosa* had the normal diploid female complement of 14 chromosomes consisting of a pair of X chromosomes and 6 pairs of autosomes and the male had one X chromosome opposed by 2 Y chromosomes with 6 pairs of autosomes. Occasionally intersexes found in nature had 2 X chromosomes, 2 Y chromosomes, and 3 sets of autosomes. Sex determination in this earlier data, as summarized in Tables 3 and 4 of Yamamoto's excellent 1938 paper, when analyzed by us utilizing the methods of least squares, showed that X chromosomes had large female effects in both euploids and aneuploids whereas the net effects of the Y chromosomes and autosome sets were but one-sixth to one-tenth as great and in the male direction. Since that time great advances have been made through the studies of Yamamoto (1938), Löve (1944), Smith (1955), Löve and Sarkar (1956), and Löve (1957). As Bridges foretold in 1939, "It may now be suggested

from genetic studies that the occurrence of translocations is responsible for (a) the production of multiple elements from originally single elements, for (b) the frequent change in type of sex chromosome configuration in closely related forms, such as in the various species of *Rumex* and *Humulus*, and for (c) the associations and non-random segregation of compound elements." The predictions have been borne out in the complex chromosomal and genetic systems observed in some of the more recent studies.

Polyploids and trisomies of *R. acetosa* were studied, particularly by Ono (1935) and Yamamoto (1938). Yamamoto identified each chromosome found in each sex type. He showed that the 6 pairs of autosomes were not equally balanced toward the promoting of the male sex. The chromosomes called  $a_1$ ,  $a_4$ , and  $a_6$ , had net effects toward the males, whereas chromosome pairs denoted by  $a_2$  and  $a_5$  had net effects toward female determination. Different balances of the different chromosome types and pairs lead to the production of types named after those of Bridges, supermales, males, intersexes, females, triploids, and superfemales.

In his studies of euploid types, Yamamoto set up ratios similar to those used by Bridges in *Drosophila*, except that he gave the X chromosome a weight of 100 and each set of autosomes a weight of 60. Like Bridges he considered Y chromosome empty of sex genes. By using these weights he was able to arrange the sex types in a consistent series in which the so-called supermales had an index of 0.56, the males 0.83, the intersexes 1.11 to 1.43, females 1.67, and superfemales 2.50. As in *Drosophila* the assigning of these different values was handicapped by the lack of any really quantitative measure of the sex evaluations.

If Yamamoto's carefully tabulated data are assigned 1 for male, 3 for female, 2 for intersex, 3.5 for superfemale, and 0.5 for supermale and then analyzed by least squares for the effects of the different chromosomes on sex, the resulting equation is

$$\begin{aligned} \text{Sex value} = & 1.96 + 1.09 X - 0.18Y_1 \\ & - 0.27Y_2 - 0.28a_1 + 0.06a_2 - 0.08a_3 \\ & - 0.23a_4 + 0.12a_5 - 0.23a_6. \end{aligned}$$

The X chromosomes contribute a strong female influence and each Y a less effective male influence. The autosomes  $a_1$ ,  $a_4$  and  $a_6$  are somewhat more potent toward the male type than the Y chromosomes. Chromosomes  $a_2$ ,  $a_3$ , and  $a_5$  have their sex genes almost in balance. As may be noted, this form of quantitative analysis leads to conclusions in agreement with those of Yamamoto.

In another section of the genus, *Rumex paucifolius*, Löve and Sarkar (1956) have analyzed a tetraploid type with 28 chromosomes. The sex chromosomes were suggested as of the XXXX and XXXY types, the male being heterogametic. The X chromosomes were the longest whereas the Y was the smallest chromosome in the complement. They concluded that the mechanism of sex determination in this species is dependent on the Y chromosome's having strongly epistatic male determinants. This conclusion was based on the fact that the species is dioecious and the belief that the plants are polyploids so that the sex mechanism must be based on strong male determinants in the Y chromosomes. The strength of these male determinants is suggested to be less than to allow the production of dioecious hexaploids, inasmuch as the tetraploid included not only true females and males, but also a low frequency of androgynous individuals (Löve, 1957).

In another group of species classified by Löve (1957) in the subgenus *Acetosella* there were 5 species: 2 diploid, 1 tetraploid, 1 hexaploid, and 1 octoploid. The diploid species have the XX and XY arrangement. The natural tetraploid, *R. tenuifolius*, shows about the same degree of pairing at meiosis as do hybrids between it and experimentally produced panautotetraploids of *R. angiocarpus*. The natural tetraploids show 4 X's or 3X + Y for the females and males. Hexaploids derived by allopolyploidy from the diploid *R. angiocarpus* and the tetraploid *R. tenuifolius* have 6 X chromosomes for the female and 5X + Y for the male. Similarly the octoploid *R. graminifolius* is an autotetraploid of *R. tenuifolius* with 8 X chromosomes in the female and 7X + Y in the male. Only in this stage do slightly intersexual individuals occur as 2N = 57 or 58 chromosomes

instead of 56. At least one of the extra chromosomes is an X. From these observations Löve (1957) concluded "detailed studies and comparisons of the sex chromosomes and their pairing in natural and experimentally produced polyploids lead to the conclusion that the sex mechanism in this group must be based on the evolution of a strong male determinant in the Y chromosome, of much the same kind as in Melandrium, but stronger."

Within this one genus, *Rumex*, species are present which seem to have the male determining elements (a) located in the autosomes as in *Drosophila*, and (b) in the Y chromosomes as in man. When contrasted with the female-determining elements of the X chromosome these male elements seem to vary in their sex-determining capacity in the different species.

#### C. SPINACIA

Spinach is dioecious but the X and Y chromosomes are cytologically indistinguishable from each other in at least some species. *Spinacia oleracea* has 6 chromosome pairs. Recent work on sex-determining mechanisms for this species has been conducted by Bemis and Wilson (1953), Janick and Stevenson (1955a, b), Dressler (1958), and Janick, Mahoney and Pfahler (1959). Dressler has indicated that each pair of the 6 chromosomes can be identified by different morphology although most other investigators have been unable to make these separations within their own material. He assigns the role of sex differentiation to the chromosome pair having the largest size. The Y chromosome bears a satellite, whereas the X chromosome does not. Janick and Ellis (1959) located the sex chromosome pair through the use of the six primary trisomies each of which is differentiated morphologically. These trisomies have been obtained as progeny from triploid pistillate XXX bred to diploid staminate XY. Five of the crosses between staminate plants of the six trisomies mated with pistillate diploids gave the one male to one female sex ratio indicative of independence of the sex complex from the particular trisomies. The sixth cross utilizing the *reflex* trisomie gave a one male to two female ratio indicative of the sex complex being within the chromosome

pair which in triploid condition showed the reflex type. Each of the morphologic trisomies was associated with one of the six chromosomes. The chromosome associated with *reflex* trisomie, the sex chromosome, is the longest chromosome and is characterized by submedian centromere. In the somatic cells Janick and Ellis were unable to observe obvious heteromorphism in this chromosome pair. These results, although not agreeing in detail with those of Zoschke (1956) and of Dressler (1958) confirmed the existence of races which differ with respect to morphology of the chromosomes containing the XY factors. Janick and Stevenson (1955b) considered that the monocious character did not depend on unaltered balance between the X and Y factors but seemed to be caused by an allele as well as by other modifying genes. They found that in polyploidy the sex expression in spinach indicated that a single Y factor was male-determining even when opposed by three doses of the X. In their results only the XX, XXX, and XXXX formed pistillate flowers, whereas the XY, YY, XXY, XXXY, and XYYY were of the staminate type. Extra doses of the Y may have further effects as illustrated by the fact that YY plants do not produce seed, whereas sometimes the XY staminate progenies obtained from selfing staminate plants do, indicating that staminate plants come to their fullest expression with the YY genotype. Chromosome recovery in the progeny from crosses of 2N females mated to 3N (XYY and XXY) males revealed that the functional gametes from staminate triploids were not confined to X and X + 1 types (Janick, Mahoney and Pfahler, 1959). The progeny produced contained 49 per cent diploids, 18 per cent trisomies, 0.5 per cent 14 chromosomes, 1.2 per cent 16 chromosomes, 11 per cent 17 chromosomes, 19 per cent triploids, and 0.8 per cent 19 chromosomes. The reciprocal cross in which the female was of the 3N type and the male 2N gave distinctly higher ratios of aneuploids. Of the progeny, 28 per cent were 12 chromosomes, 36 per cent were 13, 7 per cent were 14, 0.9 per cent were 15, 2.8 per cent were 16, 13 per cent were 17, 13 per cent were 18, or 60 per cent of the total progeny were aneuploids, whereas in the

reciprocal cross the value was 31. Aside from some indication of preferential X-YY segregation in the triploid staminate parent when mated to the 2N female, the data fit expectations for the segregations of the Y chromosomes rather well. Staminate flowers were unaffected by such environmental variables as temperature and day length, whereas the monoecious and some pistillate types tended to increase in maleness at the high temperature of 80°F. and short day length (Janick, 1955).

#### D. ASPARAGUS

*Asparagus officinalis* plants are ordinarily staminate or pistillate with occasional rudimentary organs of the opposite sex appearing in both the staminate and pistillate flowers. The staminate and pistillate plants ordinarily represent approximately equal numbers. The rudimentary organs of the male sex sometimes develop and form seed. Rick and Hanna (1943) have showed that when such seeds were planted, 155 males to 43 females were produced. The data suggested that maleness depends on a dominant gene with the homozygous and heterozygous types indistinguishable. This conclusion was supported by Snee (1953). The data further showed that the proportion of staminate plants producing seeds was apparently influenced by both heredity and environment, in that seed production in these staminate plants was enhanced in some inbred lines but at the same time showed rather wide variability from plant to plant.

#### E. HUMULUS

*Humulus* sex chromosomes have been identified by Jacobsen (1957) in two species, *H. lupulus* and *H. japonicus*. *H. lupulus* has a complement of 20 chromosomes in mitosis. The X chromosome is identifiable and separable from the Y chromosome in both mitosis and meiosis. The X chromosome is longer than the Y but is of medium size compared with the autosomes. *H. japonicus* has 17 chromosomes in the male and 16 chromosomes in the female at mitosis. There are two Y chromosomes Y<sub>1</sub> and Y<sub>2</sub> and an X in the male in both mitotic and meiotic divisions. The female has two X chromosomes. In both species the sex chromosomes in prophase and prometaphase

are differentiated to show the position and extent of the homologous and differential segments. The Y chromosomes are highly heterochromatic. Based on Ono's 1940 work on triploids derived from crosses of diploids and colchicine induced tetraploids in *H. japonicus*, Westergaard (1958) concludes that the preliminary evidence suggests that sex determination in *H. japonicus* follows the arrangement of *Drosophila* in that the X chromosomes are female determining and the autosomes carry the male inheritance.

Sex differentiation in other sex dimorphic higher plants follows patterns like those represented by one or another of the plant species discussed above.

### VII. Mating Types

Species without morphologic sex differences, which occur as unicellular and as haploid forms, often show differences in their behavioral relations to each other. The types may be alternate. Blakeslee (1904) first called attention to these reactions in heterothallic fungi in which the opposite mating types were so indistinguishable morphologically that opposite types were designated as + and -. Preliminary criteria, to be met in assigning the + and - types, were: (1) the individuals studied should be shown to be in fact sexually dimorphic and not merely hermaphrodites or sex intergrades; (2) tests should include a large number of races in order to show that the differences are truly related to behavioral differences in reproduction and are not secondary characters peculiar to a race; and (3) the strengths of the reactions should be graded in order to correlate them with any sex differences that might be observed (Santina and Blakeslee, 1925). From more than a quarter century of study, Blakeslee and his group working on some 2000 races included in 30 species of 15 genera came to the belief that over this large group of heterothallic mucors strict sexual dimorphism was the rule. Similar systems have extended the concept far beyond this group of fungi.

In fungi Raper (1960) emphasizes the role of gene differences in the control of sex. Genetic mutations have furnished evidence to show that future sexual capacity follows segregation of genetic factors at meiosis. These factors impose changes in differentia-

tion which affect type compatibilities. The work of Esser and Straub (1958) on 21 irradiation mutant strains is cited. Of the 21 strains, 18 were sterile when grown alone. These mutants could be divided into qualitatively different groups in terms of the stages at which sexual isolation was achieved. Three strains developed only vegetative mycelia; 3, ascogonia but no protoperithecia; 6, few to many protoperithecia but no perithecia; 6, sterile perithecia; and 3, fertile perithecia with nondischarging asci. Four mutant types were observed more than once. The results suggested single factor changes each affecting a single essential factor product significant to further sexual development. Restoration occurred by pairing with wild type alleles in heterokaryons derived from hyphal fusions between the two defective strains. Fertility is sometimes noted in pairing of self-fertile strains apparently mediated through the cytoplasm. Diffusible agents, hormones and surface agents may all play a part in fertility. In some features the results in fungi suggest the wide range in fertility phenotypes of gene origin so frequently isolated in *Drosophila* experiments. Together with much other material they furnish further evidence for a multigenic basis for sex-controlled characteristics.

Physiologic differentiation of individuals of a species into diverse mating types was notably extended by Sonneborn's (1937) discovery that in *Paramecium aurelia* two classes of individuals exist. Members of different classes unite for conjugation; members of the same classes do not. Information on these types has accumulated rapidly during the last few years (Jennings, 1939; Sonneborn, 1947, 1949, 1957). As a rule *P. aurelia* has two and only two interbreeding mating types in a variety. In general mating types from different varieties do not react to each other. Death or low viability follows in a few cleavages for some of the rarely interbreeding mating types. In *P. bursaria* Jennings and his group discovered six varieties each of them comprising a set of mating types. A system of at least four mating types is known for varieties I, III and VI; eight are found in variety II; IV has two and V is represented by but one. Similar

mating type systems are found in other genera, *i.e.*, *Euplotes* (Kimball, 1939).

Mating systems have been demonstrated for some species of bacteria. A strain in order to show conjugation followed by transfer of separate genetic entities requires at least two different types of individuals. Ravin (1960) has recently reviewed this subject for bacteria. The  $F^+$  and the  $F^-$  cell types when intermixed will conjugate and show detectable rates of interchange for genetic materials in tests of subsequent progenies. The  $F^-$  and  $F^-$  when mixed do not show recombination. The  $F^+$  and  $F^+$  when mixed may show low rates of interchange which have been suggested as due to the presence of physiologic  $F^-$  variants sometimes found in genetically  $F^+$  isolations. The postulated  $F^+$  and  $F^-$  factors suggest relations similar to those of some of the genes in higher animals or plants. The  $F^+$  factor has a property that may set it apart from these genes. In the presence of  $F^+$  cells,  $F^-$  cells adopt the  $F^+$  mating type. The reaction is suggestive of that taking place within the male sex in *Bonellia* as observed by Baltzer.

In the absence of visible morphologic differences which enforce exchanges and recombinations of genetic materials, the physiologic or submicromorphologic conditions found in either haploid or diploid unicellular organisms accomplish the same objectives by establishing mating types. Whether these differences are really comparable with sex and sex determination is still an open question. There may be some ground for thinking that there are precursors which assist in the development of such systems.

## VIII. Environmental Modifications of Sex

### A. AMPHIBIA

Amphibian sex chromosomes, *Ambystoma*, *Siredon*, *Pleurodeles*, *Triton*, *Triturus*, *Rana*, and *Xenopus* as found in nature are ZZ for the males and WZ for the females. Sex reversal of the normal sex phenotypes has been particularly successful in this class of animals and under a variety of conditions (for further information see Chapter by Burns). The haploid chromosome numbers for the males of these various



genera are 12, 14, and 18, with no sex chromosomal differentiation. Types having haploid, diploid, triploid, tetraploid, pentaploid, hexaploid, heptaploid, and various aneuploid chromosome numbers have been observed under experimental conditions (Humphrey and Faulkhauser, 1956; Faulkhauser and Humphrey, 1959). Humphrey (1945) induced sex reversal by grafting testicular primordia on to embryonic genetic female gonads. He showed that males having the genotype WW were viable, as were females having the same constitution. The somatic cells could be modified to either sex phenotype whereas the germ cells retained their genotypic constitutions as observed later under natural and hormone control as in fish.

The improvement of estrogenic hormones facilitated further studies on this problem. Under natural conditions the sex genes are effective sex determiners as normally they guide the developing organism into one or the other of the definite sex phenotypes. When the embryonic forms of newts or toads were exposed to relatively high concentrations of sex hormone-like substances of the other sex, growth and development were guided toward that sex rather than toward that expected from the chromosomal constitution of the somatic cells (Gallien, 1954, 1955, 1956; Chang and Witschi, 1955, 1956). When the male genotype was converted to the female phenotype through this treatment and was later bred to a normal male, the progenies as expected on the basis of the chromosomal constitution were all normal males. When the female WZ was sex-reversed to the male phenotype and then bred to a normal female the progenies were of three types, from a chromosome standpoint ZZ, WZ, and WW, the ratio being 1 male to 3 females. The derived WW type was then of female constitution showing that this chromosome carries genes which normally guide the organism to the female phenotype. WW individuals had an adequate gene content for normal development of either sex in this class of organisms. The observations on sex reversal in amphibia were reminiscent of the experimental analyses of sex differentiation by Baltzer on Bonellia (1935) in which he quoted Harrison (1933) as saying, "A score of different

factors may be involved and their effects most intricately interwoven. In order to resolve this tangle we have to inquire under as great a variety of experimental conditions as is possible to impose. Success will be assured by the implicity, precision, and completeness of our descriptions rather than by a specious facility in ascribing causes to particular events." Bonellia showed the way for synthetic hormone in that contact of the embryonic form with the female was sufficient to direct development into the male type.

#### B. FISH

Sex determination in fish as in Amphibia seems to be of such a nature that the results of hormone treatments are revealed more clearly than in *Drosophila* or mammals. Winge (1922) found 46 chromosomes in both male and female guppies. *Lebistes reticulatus* has 22 pairs of autosomes and 2 X chromosomes in the female and 22 pairs of autosomes and an XY chromosome set in the male. Normally the Y chromosome is found only in the male and is transmitted to only male progeny. The genetic factors contained in the differential segment of this chromosome are not found in the females, but are transmitted to all the young of the male sex. The pairing segment on the other hand crosses over with the X. Whether the Y chromosome itself also is sex deciding is uncertain. As Winge said in 1922, "experiences gained from the *Drosophila* researches have proved that one must indeed take care not to state anything certain on this subject."

A fairly large number of genes had been demonstrated in the X, Y, and autosomes of this species by 1934. Genes which showed X linkage showed crossing over to the Y chromosome and vice versa (Winge, 1934; Winge and Ditlevsen, 1948). The amount of crossing over showed some variation depending on what genes were present in the two chromosomes. A locus was found in the Y chromosome containing a set of alleomorphic genes which could not cross over to the X chromosome. These alleles were completely linked with a male-determining element found in this Y chromosome and located near its end. The pattern of inheritance for chromosome sex determination

was apparently XX for the female and XY for the male. Events observed in selection experiments for sex completely altered this behavior. A pair of autosomes took over the role of the sex chromosomes in the experimentally produced race. The males as well as the females were found to have the XX chromosome arrangement. In effect the X chromosomes became autosomes and the X-linked genes were transmitted autosomally. Pure males and pure females were generally obtained in the progeny for this race, but sex differentiation was so weak that the sex percentage was subject to wide variations between broods and the expected 50 per cent males to females was observed only during the spring months. Winge interpreted these results as indicating that there were both masculine and feminine elements present in the autosomes as well as in the XY chromosomes which contributed to the determination of sex. Selection sorts out different proportions of these elements and a change occurs in the mechanism forming the sex phenotype. XY females were produced which when crossed to XY male segregates gave as expected 3 males to 1 female. On this basis the YY individuals were found. The YY males on crossing with normal females produced only male offspring just as previously the XX males when crossed to normal females gave only female offspring.

Changes of a similar type have been found in nature. Gordon (1946, 1947) observed wild stocks of the platyfish, *Platy-pocillus maculatus*, from Mexico which were XX for the female and XY for the male. Platyfish from rivers in British Honduras on the other hand were WZ for the female and ZZ for the male. The W and Y chromosomes have many common characteristics. Breeding data on domesticated platyfish uncovered similar exceptional chromosomal types with corresponding differences in the sex transmission. Breider (1942) observed an exceptional WZ male which when mated to a normal female WZ had 51 daughters and 13 sons in the progeny. The ratio is such as to indicate that the females were a mixture of WW and WZ genotypes. That this was probable was indicated by the work of Belkamy and Queal (1951). Again an exceptional WZ male in

matings with WZ females had female progenies of two types, WW and WZ, the males being ZZ. The WW females were proved by mating to normal males, ZZ, and obtaining progenies which were entirely females. The results indicated that the WW females were less fertile and so would soon be replaced in nature by the WZ type. Aida (1921, 1936) located genes in the X and the Y chromosomes of another genus of fishes, the medaka, *Oryzias latipes*, and studied the effects of these chromosomes on sex determination and sex reversal. The chromosome number for the diploid was apparently 48 with no prominent morphologic difference between the X and Y chromosomes. The males were XY and the females XX. By selection for high male ratios, lines were established in which the male offspring far exceeded those which were female. Females having the genotype XY were isolated which on crossing to normal males gave the ratio of 3 males to 1 female. One-third of the male offspring were of the YY constitution so that as with the platyfish this type was viable. In interpreting these results the primary sexual characteristics are held to be determined by respective genes distributed throughout the autosomes and set into activity by stimulating genes. The female genes were held to require greater stimulation than the male genes to be active and produce their phenotypes. Sex was viewed as determined by the differences in quantity of the stimulating genes. Between these two quantities a threshold was postulated above which the female and below which the male genes were stimulated. Sex reversal and differences in sex ratios among the offspring of these fish from sex reversed males were explained as due to fluctuations of the stimulating power or potency of the X chromosome.

Yamamoto (1953, 1959a, b) showed the possibility of reversing the phenotypic sex by incorporating sex hormone-like substances in the diets of the developing young. Functional sex reversal of the male genotypes XY to those having female phenotypes was accomplished by introducing estrone or stilbestrol into the diet for 6 to 10 weeks to the extent of 50  $\mu$ g. per gm. diet from 1-day-old fry to those 11 to 16 mm. in length. Mating these estrone sex

reversed mothers XY, to normal males XY, resulted in progenies containing 1 female to 2.2 to 2.4 males where the expected theoretic relation would be 1 female to 3 males. The male progenies were submitted to test crosses. It was shown that the YY individuals were, as expected, males. With the removal of hormone feeding the normal sex-determining mechanism reestablished itself as XX for the female and XY for the male in the following generation. The hormone feeding had apparently, through its excess female-stimulating growth capacities, caused the somatic tract of the fish to develop throughout as a female but did not in any way influence the fundamental genetic constitution of the cells. In at least one case (1957), Yamamoto has shown that true intersexes can be produced having the genotype XY. The secondary sex characters were intermediate between both sexes. The gonads became ovotestes, testicular elements in the anterior and ovarian components in the posterior region. By use of the same technique, but substituting methyl testosterone as the hormonal additive to the diet at the beginning of the indifferent gonad stage and continuing through sex differentiation, it has been possible where quantities of 50  $\mu$ g. per gm. diet were fed in the diet to cause both genetic sexes XX or XY to differentiate into males with rudimentary testes which eventually become neuters on becoming full-grown fish. Intermediate dosages resulted in XY individuals becoming males and in 3 cases intersexes. These phenotypic males of the XX type became fertile, producing spermatozoa which on fertilization of eggs of normal females gave all female progeny. Again the effect of the sex hormone was temporary in that only the treated generations showed the sex reversal, their progeny returning to the customary XX female and XY male types. Sex reversals have been accomplished on fish that were themselves progeny of sex-reversed parents. Genetic analyses showed that the sex-reversed males were all XY genotypes rather than YY genotypes. This was accounted for through the low viability of the males of the YY genotype.

These observations are similar to those observed in some of the Amphibia and are also of interest in connection with the regu-

lar sex mechanisms which have developed for *Sciara* or for those of occasional abnormal types as those observed in *Drosophila* and man. These cases make it evident that phenotypic sex may be derived in a quite different manner from that adduced by the sex promoting genes carried through the germ line, even though the germ line may be nourished by the products of the phenotypic somatic cells. The time in development when the presence of hormone in excess of and external to the organism's own gene initiated sex organizers, if it is to be effective, would seem to be important. The brief embryonic stage before the determinative changes in sex primordia have occurred, the neutral stage or stage of bisexual potentiality, is likely to be most influenced by external agencies that redirect sex differentiation. Developmentally speaking, this period is rather short for the primary sex organs, although possibly longer in terms of some secondary sex characters such as the breasts in man.

#### IX. Sex and Parthenogenesis in Birds

Sex in birds follows the general ZW + 2A for the female and ZZ + 2A for the male; sex-linked genes follow this pattern. Although breeding results in general follow expected orthodox lines, the birds are subject to much mosaic variation in their color patterns as well as significant sterility relations in species hybrids. Sectorial mosaics are prominent. Some of these can be accounted for by nondisjunction, polyspermy, binucleate eggs fertilized by different sperm, development of supernumerary sperm and other known genetic means, whereas others still lack adequate information. Gynandromorphs have been described, but are subject to question in view of the plumage characteristics observed in mosaics and because of the fact that the sex hormones are such that striking plumage differentiations may occur if for any reason, for instance disease, the hormone-producing organs are removed from the birds. In ordinary fowl the ovary produces hormones which suppress male plumage, whereas in the seabright male a gene controlled change in the testis has taken over this functional attribute. Mottling and flecking are also common, particularly in the plumage pat-

terms although seldom in the structural elements of the body. This may be interpreted in a variety of ways, including mutation and various types of chromosomal interchange in either somatic cells or those incorporated into the germ cell tract. The permanence of feather type differentiation in grafts has been demonstrated by Danforth (1932) and others. Conditions for sex variability have certainly been demonstrated as present in the bird (Hollander, 1944). Crosses between species of birds have led to sterile hybrids and to rather extensive discussions of sex reversal in the development of such forms. In their hybrids between pigeons and ring doves, Cole and Hollander (1950) presented a summary of their evidence as well as a review of this literature. Female hybrids rarely resulted from pigeon sires mated to dove females but were readily produced in the reciprocal crosses. Surviving female hybrids produced no eggs. Male hybrids produced abundant sperm but varied greatly in the proportion of sperm which seemed normal. In the backcrosses to pigeons practically no fertility was shown, but in back-crosses to doves over 2 per cent gave fertile eggs and 9 of these eggs hatched. All back-cross specimens were males and have proven sterile, but testes and semen were not examined. With minor exceptions the expression of some 20 mutant genes studied was not different from that of the pure species. Recessives were not expressed in the hybrids whereas most of the dominants gave their customary phenotypes. Sex-linked mutants were transmitted as expected for each sex. This was particularly important as the result of the inheritance of these sex-linked characteristics showed that sex reversal did not occur.

Eggs from virgin hens are known occasionally to undergo some development of the germinal discs. In dark Cornish chickens Poole and Olsen (1958) observed that some parthenogenetic development was present in 57 per cent of the eggs from their total flock. Factors stimulatory to parthenogenesis were noticeably higher in hens of some strains than in those of others. Birds within the flock differed in parthenogenetic rates from 100 per cent to 43 per cent. After incubation for a 9- to 10-day period, 3.9 per cent of the A strain, 0.7 per cent of the B strain,

0.4 per cent of the C strain showed some parthenogenetic development. In the experience of these observers these birds showed more development than is found generally in the domestic fowl. Yao and Olsen (1955) showed that, in 95 per cent of the instances when parthenogenetic development was encountered, the growth consisted solely of extra embryonic membranes. In the remaining 5 per cent growth was more advanced, ranging from the presence of blood and blood vessels only, to the presence of well formed embryos in others. The cells were diploid and were able to reproduce themselves by mitotic division. When work on the turkey was begun in 1952, 17 per cent of the eggs began a limited cleavage on being incubated. Two embryos attained the size of normal 3-day embryos. In 1958, among 7269 eggs, 15 per cent were found to contain blood of embryonic origin. Embryos of various ages were encountered in 9 per cent. Fifteen poults of parthenogenetic origin were hatched in the 1958 season. No multinucleated or polyploid cells were found in these turkeys. These poults, as with others, have always been males. Survival of parthenogenetic types generally ranges from a few hours to several days.

In experiments with fowl pox it has been shown that the number of eggs developing parthenogenetically increases considerably following vaccination. The factors leading to parthenogenesis are considered to be the genetic characteristics of the strain of birds and the presence of an activating agent or agents in the blood stream of the hens.

The parthenogenetic forms are of particular interest to the problem of sex determination. The females should be producing two types of oocytes  $Z + A$  and  $W + A$  of which presumably the  $Z + A$  alone survive since the embryos capable of being sexed are all males. The embryos are also diploids. The  $2Z + 2A$  could be derived from a fusion of the  $Z + A$  polar body nuclei as noted earlier or possibly chromosome doubling coming later in the early cleavage. A genetic element seems partially to control the parthenogenetic process. Chromosome doubling would lead to cells with identical pairs of chromosomes. The gene would be homozygous. Inbreeding of poultry leads to a continuing and rapid loss in the viability of

most strains of chickens. A greater loss would be expected for truly homozygous chickens or poults as birds are known for the large numbers of sublethal genes they carry. In fact, it is surprising that any survive to the adult stage.

The doubling of the W and A type would result in individuals lacking the Z chromosome. From what was observed in Amphibia and fish the WW + 2A, individual if it survived, would be expected to be female. Since this type has not as yet been detected it may be inferred that it is inviable because of loss of certain essential genes in the Z chromosome.

## X. Sex Determination in Mammals

### A. GOAT HERMAPHRODITES

Goat hermaphroditism as reported by Asdell (1936), Eaton (1943, 1945) and Kondo (1952, 1955a, b) is of particular interest when compared with human hermaphroditism as observed by Overzier (1955) and of testicular feminization as reported by Jacobs, Baikie, Court Brown, Forrest, Roy, Stewart and Lennox (1959) and others. In each species the phenotypic range in sexual development extended from nearly perfect female to nearly perfect male, with the most frequent class as an intermediate. External appearance of each was partially correlated with internal structure. When internal female structures as the Müllerian ducts were present, the external appearance was more female-like. When the male structures Wolffian ducts were developed, the external appearance was more male-like. The presence of the dual systems within certain of these hermaphroditic types indicates, as in *Drosophila*, that there is independence of development of each system without a so-called turning point calling for differentiation of the female sex followed by that of the male sex or vice versa.

In goats the hermaphroditic types were traced to the action of a recessive autosomal gene (Eaton, 1945; Kondo, 1952, 1955a, b). This gene apparently acts only on the female zygote. In homozygous condition the embryos bearing them develop simultaneously toward the male as well as toward the female types. This development resembles closely that of the Hr gene in *Drosophila*,

because, although Hr is dominant and the one in goats is recessive, they both operate only on the female type and both tend to develop jointly both male and female systems in sexual development.

One jarring note comes in relating the cytologic basis for sex determination in goats with that for the intersexes. The sex ratios for the different crosses clearly place the hermaphrodites as genetic females expected to have the XX chromosome constitution. The XX constitution would then also agree with that found for human hermaphrodites as discussed later in this paper. Makino (1950) has shown for one case of the intersexual goat that its sex chromosomes were of the male type. Makino's excellent studies with other species made this observation of particular significance as it was contrary to the other morphologic and genetic evidence on these hermaphrodites. The implications were fully realized by Makino when the cytologic observations were made so that as far as possible the observations should be critical on this point. However, there are several sources of cell variation that suggest the desirability of further checks. The chromosome number of the goat is large, normal mitoses rarely appear in the gonads of the intersexes, and the chromosomes of the goat's spermatogenesis are so small as to make difficult details of structure or identification. Some of the difficulties possibly could be avoided by making tissue cultures and determining the somatic chromosome numbers of their cells.

Kondo (1955b) has shown that under the breeding conditions of Japan when the sire was heterozygous, the percentage of intersexes actually approached the expected value 7.3 per cent. When the sires were homozygous recessive individual matings showed 14.6 per cent hermaphrodites as was expected. Continued mating of homozygotes should show 25 per cent of the total kids hermaphrodites, or the equivalent of 50 per cent of the female progeny.

Hermaphroditism in goats has a further advantage in that the locus is apparently linked closely to the horned or polled condition. The horned condition, in consequence, becomes a valuable indicator marking the presence of the hermaphroditic factor in the

otherwise indistinguishable male types. With these characteristics the goat types have remarkable advantages over other species for the solution of problems of hermaphroditism.

The gene for goat hermaphroditism has even more interest when it is contrasted with that of another gene, *tra*, discovered by Sturtevant (1945). *Tra* is recessive with no distinguishable heterozygous effect. In the homozygous state it converts the zygotic female into a form with completely male genitalia and internal reproductive tract with no evidence of the female sexual reproductive system. The gene effects in *Drosophila* are more extreme than those in goats but are concordant in showing that there are loci in the autosomes which may be occupied by recessive genes having direct effects on phenotypic development of the genotypic female. This evidence indicates the significance of these genes rather than the happenstance of their being in the autosome, X or Y chromosome.

#### B. SEX IN THE MOUSE

The mouse has the XY + 38 A chromosomal arrangement for the males and XX + 38 A for the females. Similar karyotype patterns have been reviewed for some Amphibia and fish. Other Amphibia and fish may have their karyotypes reversed as both forms are found in nature or observed in breeding studies. Similar reversals may be made experimentally in the phenotypes even though the genotypes remain unaltered. Birds show the sex differentiating arrangement of ZW for the females and ZZ for the males. Parthenogenesis seems to lead to males of ZZ type in domestic fowl and turkeys. In an evolutionary sense the mammals could have originated from and perpetuated either of the major karyotype sex arrangements.

Mice and men are alike in that the X has female-determining properties and the Y male potencies. How much part the genes in the autosomes have in sex development is not yet clear. Welshons and Russell (1959) have shown that mice of the presumed XO constitution are females and are fertile. They have 39 as the modal number of chromosomes found in their bone marrow cells, whereas the genetically proven XX types have 40 chromosomes. X chromosome-

linked genes' behavior substantiate the chromosomal constitutions of XO and XX as females and XY as males.

These results are further supported by the breeding behavior of the X-linked recessive gene, scurfy (Russell, Russell and Gower, 1959). This gene is lethal to the hemizygous males before breeding. The genetics of the scurfy females have been analyzed by transplanting the ovaries to normal recipient females and obtaining offspring from them. In the scurfy stock the XO type occurred as 0.9 per cent of the progeny. The YO progeny were not identified and probably die prematurely. Nondisjunction of the X and Y chromosomes in the males could result in sperm carrying neither X nor Y chromosomes. These sperm on fertilization of the X egg would give an XO + 2A type individual. Because the result is a female, this would support the Y chromosome as of male potency. The mouse arrangement may then be expected to be like Melandrium in which a well worked out series of types is known.

*Sex ratio* in mice is strain dependent over what has thus far proven to be a 10 to 15 per cent range. Weir (1958) has shown that for two strains of mice established by selecting for low and high pH, the sex ratio figures were 33 and 53 per cent for artificially inseminated mice and 41 and 52 per cent for natural matings of these respective strains. The differential pH values for the bloods of the low line were  $7.498 \pm 0.006$  and for the high line  $7.557 \pm 0.007$  as of the sixth generation of selection. The parents with the more alkaline bloods tended to have greater percentages of males in their progenies. These results direct attention to the genotype dependent phenotypic factor which may be of some importance for variations in sex ratios.

#### C. SEX AND STERILITY IN THE CAT

The tortoiseshell male cat has long interested geneticists because it has seemed that by theory it should not be. However, nature has wonderful ways of circumventing best laid hypotheses, sometimes when they are false, sometimes when they have not been probed deeply enough. The yellow gene for coat color in cats is sex-linked. This gene operates on an autosomal background of genes for black or tabby. The females may

be phenotypically orange as the double dose,  $O/O$ , covers up the effects of the other coat color genes; or tortoiseshell,  $O/+$ ; or black or tabby,  $+/+$ . The males may be orange,  $O$ , black or tabby,  $+$ , and the type unexpected tortoise. The tortoiseshell males are timid, keep away from other males, and are generally sterile. Testes are of much reduced size and solid consistency. Exceptionally, tortoiseshell males may mate and offspring presumed from the matings may be born. Active study of these males commenced as early as 1904. Komai (1952) has offered a unified hypothesis for their origin. Komai and Ishihara (1956) have contributed added information and a review of the literature to which the reader is referred.

The cat has 38 chromosomes including an X-Y pair for the males. The tortoise males agree in having this arrangement (Ishihara, 1956), the X being 3 or 4 times the length of the Y in all cytologic preparations from Japanese cats. Komai (1952) visualizes the cat X chromosomes as composed of a pairing segment containing the kinetochore and gene loci among which is that for the orange gene and a differential segment, not found in the Y chromosome, containing the factor-complex for femaleness. The Y chromosome is visualized as having a segment containing the kinetochore and capable of pairing with the X chromosome. This segment may cross over with the X so that it may acquire the locus for orange or its wild type. The Y chromosome is viewed as containing two differential segments. The one carrying the factor complex for maleness is located to correspond with the X differential segment carrying the female sex factor. The second Y differential segment is at the other end of the chromosome and contains the male fertility complex. The tortoiseshell sterile males are interpreted as caused by a Y chromosome crossing over with the X chromosome to incorporate the male segment and the O gene in the resulting Y chromosome but with the loss of the male fertility segment. The gamete carrying this modified Y fertilizing an egg with a normal X chromosome containing the wild type instead of the O gene develops into the sterile tortoiseshell male. The data show that the probability of these events occurring is small. Komai records as reliable 65 tortoiseshell male cats where the inci-

dence of the O gene in the whole population of Japanese cats is 25 to 40 per cent. Of the 65, 3 were apparently fertile. These cases and the few others found in the literature are regarded as caused by those rare occasions when the Y chromosome incorporates the O gene but retains the male fertility complex as might occur in double crossing over. The hypothesized factor locations and crossing over arrangements also may explain the unexpected black females which are known to occur in some matings. Although not mentioned, black males and orange males showing the same sterility features as the sterile tortoiseshell males should also be found in the cat population. If found they would further strengthen the hypotheses.

It is difficult to understand why, even with its low initial frequency, the fertile tortoiseshell male would not establish itself in the Japanese cat population, inasmuch as they are so admired and sought after by all the people if any tortoiseshell males became as fertile as the tortoiseshell male "lucifer" (Bamber and Herdman, 1932) known to have sired 56 kittens.

Ishihara's work (1956) seems to close the door on another attractive hypothesis to explain the origin of these unexpected cat types. Tortoiseshell male reproductive organs include small, firm testes showing reduced spermatogonial development. Together with the interaction of the O gene with the wild type allele they suggest the human types  $XXY + 2A$  which may arise from nondisjunction. However, the chromosome type is shown to be  $XY + 2A = 38$  which is fatal to this hypothesis.

It is of interest that Komai in 1952 postulated the male complex and fertility factors in the Y chromosome of a mammal. The case has a further parallel in the plant *Melandrium* in that the work of both Westergaard (1946) and Warmke (1946) indicated the Y chromosomes of this plant to contain such factor complexes although in differing arrangements.

#### D. DEVIATE SEX TYPES IN CATTLE AND SWINE

As a caution in the mushrooming of cytologic interpretations of sex development, attention may be directed to the freemartin types known particularly from the work of

Keller and Tandler (1916), Lillie (1917), and the researches stimulated by their observations on cattle twins. The freemartin in cattle develops in the same uterus with its twin male. The blood circulations anastomose so that blood and the products it contains are common to both fetuses during development. The development of the female twin is intersexual, presumably because of substances contributed by the male twin to the common blood during uterine growth. The freemartin intersexuality may be graded into perfectly functioning fertile females to types with external female genitalia and typically male sex cords except germ cells are absent, vasa efferentia, and elements of the vasa deferentia. The conditions are similar to those discussed for amphibia, fish, and rabbits in which early sex development passes through neutral stages during which it may be directed toward one sex or the other by the right environmental stimuli.

Intersexes in swine have been interpreted as owing to similar causes (Hughes, 1929; Andersson, 1956) although the resulting phenotypes may not be quite as extreme. The resulting intersexes for both cattle and swine presumably are not caused by chromosomal misbehavior but to the right environmental stimuli operating on suitable gene backgrounds. The observations of Johnston, Zeller and Cantwell (1958) on 25 intersexual pigs all from one breeding group of Yorkshires suggest significant inheritance effects. The intersexes were of two types, "male pseudohermaphrodites" and "true hermaphrodites," but there was some intergrading of their phenotypes suggesting that they may be the products of like causes. Common organs between the two groups included uteri, vulvae, vaginae, testes, epididymis, and penis or enlarged clitoris. The "true hermaphrodites" were separated on the basis of no prostates, bulbo-urethral glands, or seminal vesicles as well as having testes or ovotestes with ovaries. A similar case was described by Hammond (1912) but, as in one of the above cases, the supposed ovaries when sectioned seemed to be lymphatic tissue. Favorable nerve tissue from 6 of the Yorkshire pigs was examined for nuclear chromatin. The cases were found chromatin positive. Phenotypically these cases also have parallels in mice and man.

#### E. SEX-IN MAN: CHROMOSOMAL BASIS

A surprise even to its discoverers, Tjio and Levan (1956), came with the observation that the somatic number of chromosomes in cultures of human tissue was 46 rather than the previously supposed 48. Search for the true number has been going on for more than half a century. In early investigations the numbers reported varied widely. Difficulties of proper fixation and spreading of the chromosomes of human cells accounted for most of this variation and the numerous erroneous interpretations. Among the observations that of de Winiwarter (1912) was of particular interest in showing the chromosome number as 46 autosomes plus one sex chromosome with the Y being absent. This number was also found later by de Winiwarter and Oguma (1926). Observations by Painter (1921, 1923) showed 46 chromosomes plus an X and a Y, a total of 48. This number was subsequently reported by a series of able investigators, Evans and Swezy (1929), Minouchi and Ohta (1934), Shiwago and Andres (1932), Andres and Navashin (1936), Koller (1937), Hsu (1952), Mittwoch (1952), and Darlington and Haque (1955). As Tjio and Levan indicated, the acceptance of 48 as the correct number, with X and Y as the sex chromosome arrangement, was so general that when Drs. Eva Hanson-Melander and S. Kullander had earlier found 46 chromosomes in the liver cells of the material they were studying they temporarily gave up the study. In the few years since 1956, the acceptance of 46 chromosomes as the normal complement of man has become nearly universal. There are 22 paired autosomes plus the X and Y sex chromosomes.

The reasons which have warranted this change of viewpoint are no doubt many, but three improvements in technique are certainly significant. The first came as a consequence of simplifying the culture of human somatic cells. The second followed Hsu's (1952) recognition that pretreatment of these cells before fixation with hypotonic solutions tended to better spreads of the chromosomes on the division plates when subsequently stained by the squash technique. Pretreatment of the cultures with



colchicine made the studies more attractive by increasing the numbers of usable cells that were in the metaphase of cell division.

Ford and Hamerton (1956) in an independent investigation, closely following that of Tjio and Levan, observed that the human cell complement contained 46 chromosomes. They, too, agreed with Painter and others that followed him that the male was XY and the female XX in composition. A flood of confirming evidence soon followed; Hsu, Pomerat and Moorhead (1957), Bender (1957), Syverson (1957), Ford, Jacobs and Lajtha (1958), Tjio and Puck (1958), Puck (1958), Chu and Giles (1959), and a number of others.

In most instances the results of the different investigators were surprisingly consistent in showing that the individual cell chromosome counts nearly always totaled 46. This was no doubt due in part to the desirability of single layers of somatic cells for identifying and separating the different chromosomes into distinct units. Chu and Giles' results illustrate this consistency. For 34 normal human subjects, including 29 American whites and 4 American Negroes, and one of unknown race, and regardless of sex, age, or tissue, the diploid chromosome number of the somatic cells was overwhelmingly 46. In only five individuals were other numbers observed in isolated cells. Out of 620 counts, 611 had 46 chromosomes; two individuals, whose majority of cells showed 46, had 3 cells with 45 chromosomes; three other individuals, the majority of whose cells showed 46, had 6 cells with 47 chromosomes. Average cell plates counted per individual was nearly 20.

The only recent observations at variance with these results were those of Kodani (1958) who studied spermatogonial and first meiotic metaphases in the testes from 15 Japanese and 8 whites. In these studies at least several good spermatogonial metaphases in which the chromosomes could be counted accurately, and secondly at least 15 spermatocyte metaphases in which the structure of individual chromosomes could be observed clearly, were made on each specimen. The numbers of cells studied in metaphase were generally above these numbers, one reaching 60 metaphases. Some variation was noted within individuals. Among

individuals, numbers of 46, 47, and 48 were observed. Among 15 Japanese, 9 had 46, 1 had 47, and 5 had 48 chromosomes, whereas among the whites 7 had 46, and 1 had 48. Sixteen of the 23 individuals had 46 chromosomes. Karyotype analyses indicated that the numerical variation was caused by a small supernumerary chromosome. On the basis of these observations it would appear that individuals within races may vary in chromosome number and yet be of normal phenotype. However, in view of the extensive observations by others, it seems unlikely that the variation between individuals is as large as that indicated. It will require much further study to establish any other number than 46 as the normal karyotype of man. This is particularly true in view of the work of Makino and Sasaki (1959) and Makino and Sasaki cited by Ford (1960), in which they studied the human cell cultures of 39 Japanese and found without exception 46 chromosomes, and the earlier work of Ford and Hamerton (1956) on spermatogonial material where they, too, found 46 chromosomes in that tissue. The best features of these human chromosome studies will come in the identification of the individual chromosomes making up the human group. The chromosome pairs may be ordered according to their lengths. The longest chromosome is about 8 times the length of the smallest. The chromosomes may be classified according to their centromere positions. The chromosomes are said by most observers to be fairly easily separated into 7 groups. Separation of the individual chromosome pairs from each other and designation of the pairs so that they can be identified by trained investigators in all good chromosome preparations is not possible according to some qualified cytologists and admitted difficult by all students. However, standardized reporting in the rapidly growing advances in human cell studies should refine observations, reduce errors, and encourage better techniques. With this in mind, 17 investigators working in this field met in Denver in 1959 in what has come to be called the "Denver conference" (Editorial, 1960). From an examination of the available evidence on chromosome morphologies an idiogram was set up as a standard for the somatic chromosome

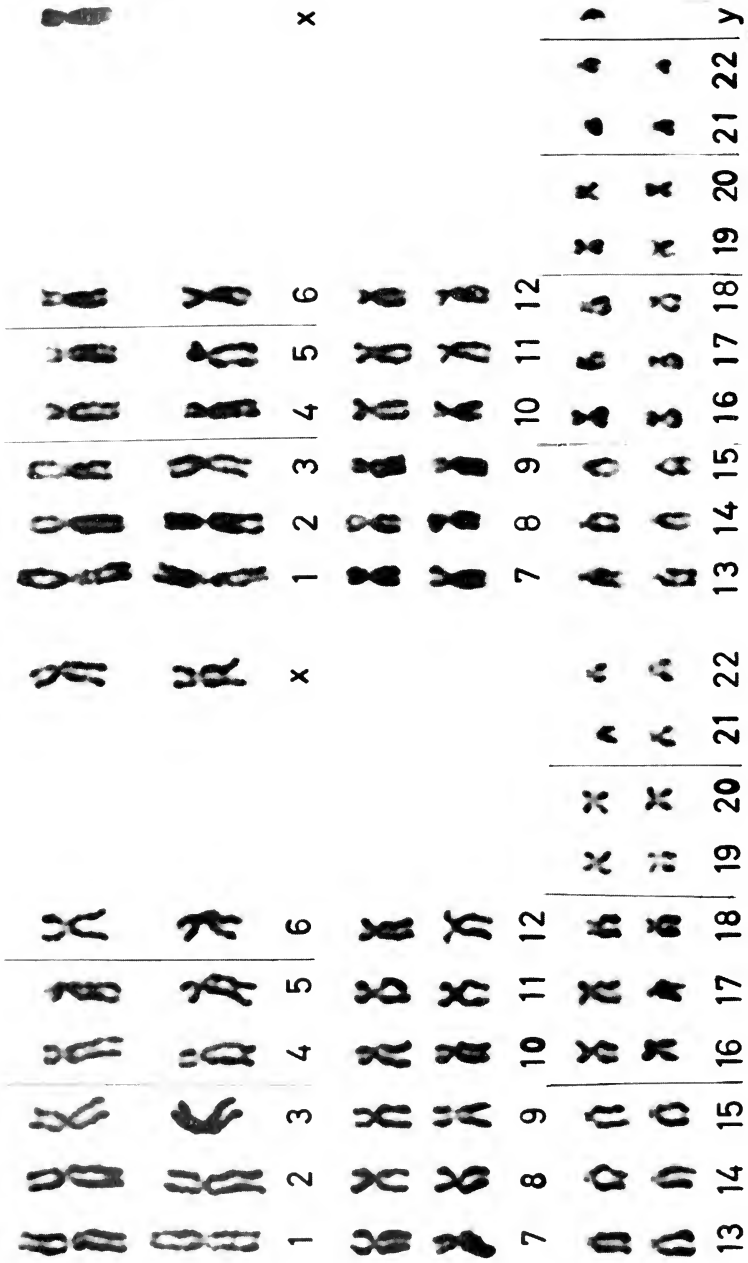

Human female

Human male

FIG. 11. Idiogram of human normal somatic chromosomes numbered according to their position in the chromosome group. Autosomes are identified by number, the sex chromosomes by X and Y. Small satellites which are not easily photographed because of their relatively weak staining, are found on chromosome pairs 13, 14, 15 and 21. Photographs courtesy of J. H. Tjio and Theodore T. Puck.

complement of the normal human genome. A reproduction of this standard is presented in Figure 1.1, as kindly loaned by Dr. Theodore T. Puck for this purpose.

The autosomes were first ordered in relation to their size and such attributes as would help in their positive identification. Numbers were given to each chromosome as a means of permanent identification. Basically, identification is assisted by the ratio of the length of the long arm to that of the short arm; the centromeric index calculated from the ratio of the length of the shorter arm to the whole length of the chromosome; and the presence or absence of satellites. Classification is assisted by dividing the chromosome pairs into seven groups.

Groups 1-3. Large chromosomes with approximately median centromeres. The three chromosomes are readily distinguished from each other by size and centromere position.

Group 4-6. Large chromosomes with submedian centromeres. The two chromosomes are difficult to distinguish, but chromosome 4 is slightly longer.

Group 6-12. Medium sized chromosomes with submedian centromeres. The X chromosome resembles the longer chromosomes in this group, especially chromosome 6, from which it is difficult to distinguish. This large group is the one which presents major difficulty in identification of individual chromosomes.

Group 13-15. Medium sized chromosomes with nearly terminal centromeres ("acrocentric" chromosomes). Chromosome 13 has a prominent satellite on the short arm. Chromosome 14 has a small satellite on the short arm. No satellite has been detected on chromosome 15.

Group 16-18. Rather short chromosomes with approximately median (in chromosome 16) or submedian centromeres.

Group 19-20. Short chromosomes with approximately median centromeres.

Group 21-22. Very short, acrocentric chromosomes. Chromosome 21 has a satellite on its short arm. The Y chromosome belongs to this group.

Separations of the human chromosome pairs into the seven groups is not as difficult as designating the pairs within groups (Patau, 1960). The system is a notable ad-

vance in summarizing visually the current information in the hope that availability of such a standard will promote further refinements, lessen misclassification, and contribute to a better understanding of the problems by cytologists and other workers in the field.

### 1. Nuclear Chromatin, Sex Chromatin

Sexual dimorphism in nuclei of man (Barr, 1949-59) and certain other mammals may be detected by the observable presence of nuclear chromatin adherent to the inner surfaces of the nuclear membrane. The material is about  $1 \mu$  in diameter. It frequently can be resolved into two components of equal size. It has an affinity for basic dyes and is Feulgen and methyl green positive. Nuclear chromatin can be recognized in 60 to 80 per cent of the somatic nuclei of females and not more than 10 per cent of males. It is known to be identifiable in the females of man, monkey, cat, dog, mink, marten, ferret, raccoon, skunk, coyote, wolf, bear, fox, goat, deer, swine, cattle, and opossum, but is not easily usable for sex differentiation in rabbit and rodents because these forms have multiple large particles of chromatin in their nuclei. The tests can be made quickly and easily on skin biopsy material or oral smears. Extensive utilization of the presence or absence of nuclear chromatin in cell samples of man has been made for assigning the presumed genetic sex to individuals who are phenotypically deviates from normal sex types. (See also chapters by Hampson and Hampson, and by Money.) Numerous studies on normal individuals seem to support the test's high accuracy. However, in certain cases involving sexual modification, questions have arisen which are only now being resolved. In male pseudohermaphroditism, sex, determined by nuclear chromatin, is male, thus agreeing with the major aspects of the phenotype. For female pseudohermaphroditism, individuals with adrenal hyperplasia or those without adrenal hyperplasia give the female nuclear chromatin test. For cases listed as true hermaphrodites Grumbach and Barr (1958) list 6 of the male type and 19 of the female type. For the syndrome of gonadal dysgenesis they list 90 as male and 12 as female among the proved cases and 15 more as female among those that are

suspected. In the syndrome of seminiferous-tubule dysgenesis where there is tubular fibrosis, 9 are listed as male and 18 female. Where there is germinal aplasia, 15 are listed as male and 1 as female. The seeming difficulties in assigning a sex constitution to some of these types are now being dissipated through the study of the full chromosome complements which are responsible for these different disease conditions. As observations on different chromosome types have been extended, evidence has accumulated to show that the numbers of sex nuclear chromatins, for at least some of the nuclei making up the organism, often equals ( $n - 1$ ) times the number of X chromosomes. The majority of male XY nuclei are chromatin negative as are most of the Turner XO type. Female nuclei XX have a single chromatin positive element as do the XXY and XXXY types. The XXX and XXXY have 14 and 40 per cent respectively with two Barr bodies in cases for which quantitative data are available. However, a child with 49 chromosomes, but whose cultured cell chromosomes appear as single heteropycnotic masses making identification of the individual chromosomes difficult, showed 50 per cent of the cell nuclei with three Barr elements (Fraccaro and Lindsten, 1960). The chromosome constitution of these nuclei was interpreted as trisomie for 8, 11, and sex chromosomes. Sandberg, Crosswhite and Gordy (1960) report the case of a woman 21 years old having various somatic changes which does not fit this sequence. The chromosome number was 47 and the nuclei were considered trisomie for the sixth largest chromosome. Two chromatin positive bodies were present in the nuclei.

## 2. Chromosome Complement and Phenotype in Man

Experience of the past 50 years has emphasized that genes and trisomies or other types of aneuploid chromosome complexes may lead to the development of abnormal phenotypes expressing a variety of characteristics. *Drosophila* led the way in illustrating how the different gene or chromosome arrangements may affect sex expression. Investigations of human abnormal types, particularly those with altered sex differentiation, have recently shown that man follows

other species in this regard. The Y carries highly potent male influencing factors. Gene differences often lead to characteristic phenotypes of unique form.

## 3. Testicular Feminization

The testicular feminization syndrome illustrates one of these types. As described by Jacobs, Baikie, Court Brown, Forrest, Roy, Stewart and Lennox (1959), "In complete expression of this syndrome the external genitalia are female, pubic and axillary hair are absent or scanty, the habitus at puberty is typically female, and there is primary amenorrhoea. The testes can be found either within the abdomen, or in the inguinal canals, or in the labia majora, and as a rule the vagina is incompletely developed. An epididymis and vas deferens are commonly present on both sides, and there may be a rudimentary uterus and Fallopian tubes. The condition is familial and is transmitted through the maternal line." A sex-linked recessive, a sex-limited dominant, and chromosome irregularities of the affected persons have been postulated as mechanisms causing the apparent inheritance of this condition. Chromosome examinations of the cells of affected persons have shown 46 as the total number and X and Y as the sex complement. The karyotype analysis agrees with the Barr nuclear chromatin test in that the cells are chromatin-negative but both are at variance with the sex phenotypes in the sense that aside from suppressed testes the patients are so completely female. Genetically, Stewart (1959) has described two color-blind patients with the testicular feminization syndrome in the first five patients he reported. The limited data from these cases suggest that the genetic basis for this condition is either independent or but loosely linked with color blindness. This evidence does not exclude sex-linkage but does make it less probable. The third hypothesis of autosomal inheritance may take one of several forms. A recessive gene which affects only the male phenotypes when in homozygous condition is apparently untenable because the matings from which these individuals come are of the outbreeding type and the ratios apparently do not differ from the one-to-one ratio expected of a heterozygous dominant instead of that re-

quired for an autosomal recessive. The hypothesis advanced by Witschi, Nelson and Segal (1957), that the presence of an autosomal gene in the mother converts all her male offspring into phenotypes of more or less female constitution, in a manner comparable to that of the Ne gene in *Drosophila* (Gowen and Nelson, 1942) which causes the elimination of all the female type zygotes, is also made unlikely by the ratios of normal to testicular feminization phenotypes observed in the progenies of these affected mothers. The evidence favors a simple autosomal dominant, acting only in the male zygotes and perhaps balanced by some genes of the X chromosome, which have sufficient influence on the developing male zygote to guide it toward an intermediate to nearly female phenotype. The observations of Puek, Robinson and Tjio (1960) indicate that the action of a gene for this condition may not be entirely absent in the female, because in heterozygous condition in an XX individual it seemed to delay menarche as much as 8 years. If this delay be diagnostic for the heterozygote, it will further assist in the genetic analysis of this problem. Evidence on this point should be a part of the genetic studies.

Cases closely similar to those described by Jacobs, Baikie, Court Brown, Forrest, Roy, Stewart and Lennox (1959) are presented by Sternberg and Kloefer (1960). The patients show no trace of masculinity. They are remarkably uniform in anatomic expression. Except for failure to menstruate due to lack of uteri they undergo normal female puberty. Cryptorchid testes, usually intra-abdominal, if removed precipitate menopause symptoms. Four unrelated cases were found in this one study with 7 additional cases traced through pedigree information. A total of 11 affected individuals was found in 6 sibships having 26 siblings of whom 5 were normal males. In each kindred the inheritance was compatible with that of a sex-linked recessive gene. A chromosomal study of a thyroid tissue culture from one case revealed 46 chromosomes with normal XY male configuration. The individuals observed were designated as "simulant females."

#### 4. Superfemale

The human superfemale has been recognized by Jacobs, Baikie, Court Brown, MacGregor, Maclean and Harnden (1959) in a girl of medium height and weight, breasts underdeveloped, genitalia infantile, vagina small, and uterocervical canal 6 cm. in length. Ovaries appeared postmenopausal with normal stroma, and as indicated by a biopsy specimen, deficient in follicle formation. Menstruation was thought to have begun at age 14, but was irregular, occurring every 3 to 4 months and lasting 3 days. The last spontaneous menstruation was at 19. Estrogen therapy caused some development of the breasts and external genitalia, vagina, and uterus with slight uterine bleeding. The patient's parents were above 40 years of age, mother 41, at time of her daughter's birth.

Examination of sternal marrow cultures showed 47 chromosomes in over 80 per cent of the cells examined. The extra chromosome was the X, the chromosomal type being XXX plus 22 pairs of autosomes. Buccal smears showed 47 per cent of nuclei contained a single chromatin body and 14 per cent contained 2 chromatin bodies as expected of a multiple XX or XXX genotype. In comparison, 25 smears from 20 normal women had 36 to 51 per cent chromatin positive cells but none of these contained 2 chromatin bodies. Two chromatin bodies were seen in some cells of the ovarian stromal tissue. The patient showed a lack of vigor, mentally was subnormal, was underdeveloped rather than overly developed in the phenotypic sexual characteristics. Examination of the patient's mother showed her to be XX plus 22 pairs of autosomes, the normal 46 chromosomes.

Other cases show that types with XXX plus 22 pairs of autosomes are of female phenotype but may vary in fertility and development of the secondary sexual characteristics from nonfunctional to functional females bearing children (Stewart and Sanderson, 1960; Fraser, Campbell, MacGillivray, Boyd and Lennox, 1960). The triplo X condition in man has a greater range of development and fertility than in *Drosophila*. In man ovaries may develop spontaneously. In *Drosophila* they require transplantation

to a diploid female host where they may attach to the oviducts and release eggs for fertilization (Beadle and Ephrussi, 1937).

These cases present confirmation of two facts already mentioned for *Drosophila*. They show that when the X chromosome has primarily sex determining genes, the organism generally becomes unbalanced when 3 of these X chromosomes are matched against two sets of autosomes. The resulting phenotypes are female but relatively undeveloped rather than overdeveloped. The second is that the connotations evoked by the prefix "super" are by no means applicable to this human type or to the *Drosophila* type.

The characteristics of the patient also suggest that the autosomes may be carrying sex genes opposing those of female tendencies as observed in both *Drosophila* and *Rumex* genic imbalance.

##### 5. Klinefelter Syndrome

In the Klinefelter syndrome there is male differentiation of the reproductive tracts with small firm descended testes. Meiotic or mitotic divisions are rare, sperm are ordinarily not found in the semen. The type is eunuchoid in appearance with gynecomastia, high-pitched voice, and sparse facial hair growth. Seminiferous tubules showing an increased number of interstitial cells are atrophic and hyalinized. Urinary excretion of pituitary gonadotrophins is generally increased, whereas the level of 17-ketosteroids may be decreased. The nuclear chromatin is typically female. Of the dozen or more cases studied (Jacobs and Strong, 1959; Ford, Jones, Miller, Mittwoch, Penrose, Ridler and Shapiro, 1959; Bergman and Reitalu quoted by Ford, 1960), only one, having but 5 metaphase figures, had less than 47 chromosomes in the somatic cells and XXY sex chromosomes. That case was thought to have typical female chromosomes  $XX + 22AA$ . Two other cases were of particular interest as indicating further chromosome aberration. Ford, Jones, Miller, Mittwoch, Penrose, Ridler and Shapiro (1959) studied one patient who displayed both the Klinefelter and Mongoloid syndromes. The chromosome number was 48, the sex chromosomes being XXY and the 48th chromosome being small acrocentric.

This individual had evidently developed from an egg carrying 2 chromosomal aberrations, one for the sex chromosomes and the second for one of the autosomes. The other case, Bergman and Reitalu as cited by Ford (1960), had 30 per cent of its cells with an additional acrocentric chromosome which had no close counterpart in the normal set.

Data where the Klinefelter syndrome occurs in families showing color blindness (Polani, Bishop, Ferguson-Smith, Lennox, Stewart and Prader, 1958; Nowakowski, Lenz and Parada, 1959; and Stern, 1959a) further test the XXY relationship and give information on the possible position of the color blindness locus with reference to the kinetochore. Polani, Bishop, Ferguson-Smith, Lennox, Stewart and Prader (1958) tested 72 sex chromatin-positive Klinefelter patients for their color vision and found that none was affected by red-green color blindness. Nowakowski, Lenz and Parada (1959) tested 34 cases and detected 3 affected persons, 2 of whom were deuteranomalous and one protanopic. Stern (1959a) points out that these cases and their ratios are compatible with the interpretation of the Klinefelter syndrome as XXY. One of the deuteranomalous cases had a deuteranomalous mother and a father with normal color vision. This case could have originated from a nondisjunctional egg carrying 2 maternal X chromosomes fertilized by a sperm carrying a Y chromosome. The other two cases had normal fathers with heterozygous mothers. There are several explanations by which the color-blind Klinefelter progenies could be obtained. The heterozygotes might manifest the color-blind condition. The second hypothesis, which is favored, is that of crossing over between the kinetochore and the color-blind locus at the first meiotic division to form eggs each carrying 2 X chromosomes, one homozygous for color blindness, and the other for normal vision. An equational nondisjunction would form eggs homozygous for color blindness which on fertilization by the Y chromosomes of the male would give the necessary XXY constitution for the color-blind male which is Klinefelter in phenotype. A third possibility is that these exceptions may arise without crossing over as the result of

nondisjunction at the second meiotic division.

If the hypothesis of crossing over is accepted, the color-blind locus separates freely from its kinetochore and would suggest that the position of the locus is at some distance from the kinetochore of the X chromosome.

A disturbed balance between the X and the Y chromosomes alters the sexual type. A single Y chromosome, contributing factors important to male development, is able to alter the effects of two sets of female influencing X chromosomes. Yet two Y chromosomes in a complex of XYY plus 44 autosomes seem to have little or no more influence than one Y (Muldal and Oekey, 1960). The locations of the sex-influencing genes in man are thus more like those of the plant *Melandrium* than of *Drosophila* in which the male-determining factors occur in the autosomes. The relative potencies of the male sex factors compared with those of the female, however, are much less than those in *Melandrium*.

#### 6. Turner Syndrome

Turner's syndrome or ovarian agenesis further substantiates the female influence of the X chromosomes. The cases occur as the developmental expression of accidents in the meiotic or mitotic divisions of the chromosomes. These accidents lead to adults unbalanced for the female tendencies of the X chromosome. The gonads consist of connective tissue. The rest of the reproductive tract is female. Growth stimuli of puberty are lacking, resulting in greatly reduced female secondary sexual development. Patients are noticeably short and may be abnormal in bone growth. In its more extreme form, designated as Turner's syndrome, the individuals may show skin folds over the neck, congenital heart disease, and subnormal intellect, as well as other metabolic conditions. Earlier work (Barr, 1959; Ford, Jones, Polani, de Almeida and Briggs, 1959) shows that 80 per cent of the nuclear chromatin patterns are of the male type. Evidence from families having both this condition and color blindness suggested that at least some of the Turner cases would be found to have 45 chromosomes, the sex chromosome being a lone X (Polani, Lessof and Bishop, 1956). Work of Ford, Jones,

Polani, de Almeida and Briggs, (1959) has confirmed this hypothesis and added the fact that some of these individuals are also mosaics of cells having 45 and 46 chromosomes. The 45 chromosome cells had but one X, whereas the 46 had two X's. This finding may explain the female-chromatin cell type observed in about 20 per cent of the cases having the Turner syndrome. Such mosaics of different chromosome cell types could also be significant in reducing the severity of the Turner syndrome and in increasing the range of symptoms which characterize this chromosome-caused disease as contrasted with those characterizing Turner's disease. Further cases observed in other investigations, Fraccaro, Kaijser and Lindsten (1959), Tjio, Puck and Robinson (1959), Harnden, and Jacobs and Stewart cited by Ford (1960) have all shown 45 chromosome cells and a single X chromosome. As with the XXX plus 44 autosome superfemales, the Turner type, X plus 44 autosomes, also shows a rather wide range in development from sterility with extensive detrimental secondary effects to nearly normal in all respects. Bahner, Schwarz, Harnden, Jacobs, Hienz and Walter (1960) report a case which gave birth to a normal boy. Other cases have been described (Hoffenberg, Jackson and Muller, 1957; Stewart, 1960) in which menstruation was established over a period of years. The XO type in man and *Melandrium* is morphologically female. In *Drosophila* on the other hand, the XO type is phenotypically nearly a perfect male. It is further to be noted that the X chromosome of *Drosophila* appears to have a less pronounced female bias than that of man when balanced against its associated autosomes, inasmuch as the XO + 2A type in *Drosophila* is male as contrasted with the XO + 2A type in man which is female. At the same time it seems that the autosomes in the human may be influential in that the female gonadal development is suppressed instead of going to completion as it does in the XX type.

#### 7. Hermaphrodites

Hermaphroditic phenotypes in man, to the number of at least 74 (Overzier, 1955), have been observed and recorded since 1900. Types with a urogenital sinus pre-

dominated. The uteri were absent in some cases, even when complete external female genitalia were present. Ovotestes were found on the right side of the body in over half the cases; separate left ovaries or testes were about equally frequent; in three cases separate testis and ovary were indicated. The left side of the body showed a different distribution of gonad types; about one-fourth had ovotestes, another fourth ovaries, and one-twelfth testes. Unilateral distribution of gonad types was most frequent. The presence or absence of the prostate seemed to have significance because it is sometimes absent in purely female types. In recent literature similar cases have been called true hermaphrodites. This is an exaggeration in terms of long established practice in plants and animals where true hermaphroditism includes fully functioning gametes of each sex.

Hungerford, Donnelly, Nowell and Beek (1959) have reported on a case of a Negro in which the culture cells had the chromosome complement of a normal female 46, with XX sex chromosomes. Unfortunately, the possibility that this case may be a chromosome mosaic was not tested by karyotype samples from several parts of the body.

Harnden and Armstrong (1959) established separate skin cultures from both sides of the body of another hermaphroditic type. The majority of the cells were apparently of XX constitution with a total of 46 chromosomes. However, in one of the 4 cultures established, some 7 per cent of cells had an abnormal chromosome present, suggesting that the case might involve a reciprocal translocation between chromosomes 3 and 4 when the chromosomes were ordered according to size. All the other cell nuclei were normal. The fact that the majority of the cells in these two cases were XX and with 46 chromosomes seems to predicate against the view that either changes in chromosome number or structure of the fertilized egg are necessary for the initiation of hermaphroditism.

Ferguson-Smith (1960) describes two cases of gynandromorphic type in which the reproductive organs on the left side were female and on the right side were male. The recognizable organs were Fallopian tube, ovary with primordial follicles only, imma-

ture uterus in one case, none in the other, rudimentary prostate, small testis and epididymis, vas deferens, bifid scrotum, phallus, perineal urethra, pubic and axillary hair, breasts enlarging at 14 years. Testicular development with hyperplasia of Leydig cells, germinal aplasia, and hyalinization of the tubules was suggestive of the Klinefelter syndrome. Nuclear-chromatin was positive in both cases. Modal chromosome number was 46. The sex chromosomes were interpreted as XX. The 119 cell counts on one patient showed a rather wide range; 7 per cent had 44 chromosomes, 13 per cent had 45, 62 per cent had 46, and 18 per cent had 47 chromosomes. The extra chromosome within the cells containing 47 chromosomes was of medium size with submedian kinetochore as generally observed for chromosomes of group 3.

It is surprising that the male differentiation in these four and other hermaphroditic cases (Table 1.5) is as complete as it is. Other observations show that the Y chromosome contains factors of strong male potency, yet in its absence the hermaphrodites develop an easily recognized male system. It is not complete but the degree of gonadal differentiation is as great as that observed in the XXY + 2A Klinefelter types. The bilateral sex differentiation in hermaphrodites would seem to require other conditions than those heretofore considered.

Another case of hermaphroditism is that presented by Hirschhorn, Decker and Cooper (1960). The patient's phenotype was intersexual with phallus, hypospadias, vagina, uterus, Fallopian tubes, two slightly differentiated gonads in the position of ovaries. The child was 4 months old. Culture of bone marrow cells showed that the individual was a mosaic of two types. About 60 per cent of the cells had 45 chromosomes of XO karyotype, and 40 per cent had 46 chromosomes with a karyotype XY. The Y chromosome when present was larger than Y chromosomes of normal individuals. The change in size may be related to the association of the XO and XY cells and be similar etiologically to the case discussed by Metz (1959) in *Sciara* triploids.

There are mosaics in *Drosophila* formed from the loss by the female in some cells of one of her X chromosomes, as for instance



in ring chromosome types, which may display primary and secondary hermaphroditic development. For this to happen the altered nuclei apparently find their way into the region of the egg cytoplasm which is to differentiate into the reproductive tract. As seen in the adults, organ tissue of one chromosome type is cell for cell sharply differentiated from that of the other chromosome type with regard to sex. These observations indicate that for these mosaics the basic chromosome structure of the cell itself determines its development. In fact most mosaics of this species show this cell-restricted differentiation. Several problems arise when these well tested observations are considered in comparison with those now arising in the chromosome mosaics of the sex types in man. It would seem unlikely that the bone marrow cells or for that matter any somatic cells not a part of the reproductive tract would operate to modify the adult sex or a part thereof. Rather the developmental sequence should start from cell differences within the early developing reproductive tract. Circulatory cells or substances would be of dubious direct significance from another viewpoint. All cells of the body would ultimately be about equally affected by any cells or elements circulating in the blood. With strong male elements and strong female elements the result expected would be a reduction in sex development of either sex instead of the sharply differentiated organ systems which are observed. This raises the question, are the chromosomally differentiated cell sex mosaics primary to or secondarily derived from the tissues of the ultimate hermaphrodites? Study of the cell structure of the sex organs themselves as well as much other information will be necessary to clear up this problem.

There are, however, other types of controlled sex development, as by various genes, which lead to the presence of both male and female sexual systems. Genes for these phenotypes are relatively rare, but once found are transmitted as commonly expected. The inherited hermaphroditic cases in *Drosophila* are certainly relevant to the testicular feminization syndrome in man. Are they equally pertinent to the highly sporadic hermaphroditic forms just

considered for man? If so, they indicate a genic basis for these types which would probably be beyond the range of the microscope to detect. The low frequency of true hermaphrodites in the human, together with lack of information on possible inheritance mitigates against the genic explanation; although genic predisposition acting in conjunction with rare environmental events as occurs in our Balb Gw mice (Hollander, Gowen and Stadler, 1956) could explain the rare hermaphrodites observed in that particular line of mice and a limited number of its descendants.

#### 8. XXXY + 44 Autosome Type

The XXXY + 44 autosome type in the human has been studied by Ferguson-Smith, Johnson and Handmaker (1960) and Ferguson-Smith, Johnston and Weinberg (1960). The two cases described were characterized by primary amentia, microorchidism and by two sex chromatin bodies in intermitotic nuclei. The patients were similar in having disproportionately long legs; facial, axillary, and abdominal hair scant; pubic hair present; penes and serota medium to well developed; small testes and prostates; vasa deferentia and epididymides normally developed on both sides of the body and no abnormally developed Müllerian derivatives. Testes findings were like those in Klinefelter cases with chromatin-positive nuclei, small testes with nearly complete atrophy, and hyalinization of seminiferous tubules and islands of abnormal and pigmented Leydig cells in the hyalinized areas. The few seminiferous tubules present were lined with Sertoli cells but were without germinal cells. Nuclear chromatin was of female type. About two-fifths of the nuclei had double and two-fifths single sex chromatin. The modal chromosome count for bone marrow cells was 48, 75 per cent of the cells having this number. Chromosome counts spread from 45 to 49. This type, XXXY plus 44 autosomes, may be looked upon as a superfemale plus a Y or a Klinefelter plus an X chromosome. In either case the male potency of the genes in the Y chromosome is able to dominate the female tendencies of XXX to develop nearly complete male phenotypes.

Both cases had severe mental defects but

TABLE 1.5

Chromosome kinds and numbers for different recognized sex types in man

External Type	Numbers of Chromosomes			Missing or Extra Chromosomes	Sex Chromatin	Designating Term	Investigators*
	X	Y	A sets				
Male	1	1	2		Negative	Normal male	1
Female	2	0	2		Positive	Normal female	1
Female (rare hemophilic)	1	1	2		Negative		2
Eunuchoid female	1	1	2		Negative	Pure gonadal dysgenesis	3, 1, 5, 6
Female	1 + chromosomal rearrangement <sup>7</sup>		2	? Chromosome 3 or T(X;A)	Positive	Gonadal dysgenesis	38
Female	1	1	2		Negative	Testicular feminization	7, 8, 9, 10, 11, 39, 40
Female	2 or 1		2		Positive	Turner	40
Female	1		2		Negative	Turner type female	5, 12, 13, 14, 40, 41
Female	1 2 <sup>f</sup>	2 2	2	Small autosome	Negative	Turner	41
Female	1		2		Negative	Turner? gave birth to boy	15
Female	1	2 + 1		? Large chromosome or T(X;A)	Negative	Turner	41
Female	1 + X fragment		2		Negative ±	Turner?	26
Male	1		2		Negative	Turner	36
Male	2	1	2	X or Y	Positive	Klinefelter	16, 17, 18, 40, 41
Male	2	1	2	X or Y +21	Positive	Klinefelter mongoloid	19
Male	2	1	2	2 <sup>f</sup> mosaic	X or Y	Klinefelter	20, 21, 42
Male	2	0	2		Positive	Klinefelter	22
Male	2	2	2	YY	Positive	Klinefelter	22
Male	Interpreted as XX trisomic for 8 and 11 or as XXXX	1	2	+	Triple positive	Klinefelter	37
Male	4X + Y 3X + Y <sup>f</sup> mosaic		2	+	Positive	Klinefelter	37a
Male	1	1	2		Negative	Klinefelter	40
Female	3		2	X	Double positive	Superfemale	23, 40
Female	3		2	X	Double positive	Superfemale gave birth to children	24, 25
Male	1	1	2	2 <sup>f</sup> mosaic	Negative	Testicular deficiency	41
Female	3		2	2 <sup>f</sup> mosaic	X	Double positive	26
Female	1		2	46, 47, 48 chromosomes	Negative	Preocious puberty	41
Male	3	1	2	X, Y	Double positive		27
Male	2	1	3	X or Y +A set		Triploid	28
Hermaphrodite	2		2		Positive		29, 30, 31, 32, 33
Hermaphrodite	1	1	2	2 <sup>f</sup> mosaic	Negative	Hermaphrodite or intersex depending on definition	35, 39, 40
Intersex	1	1	2		Negative		41

\*1. Tjio and Levan, 1956.

2. Nilsson, Bergman, Reitalu and Waldenström, 1959.

3. Harnden and Stewart, 1959.

4. Stewart, 1960b.

5. Stewart, 1960a.

6. Elliott, Sandler and Rabinowitz, 1959.

7. Jacobs, Baikie, Court Brown, Forrest, Roy, Stewart and Lennox, 1959.

8. Stewart, 1959.

9. Lubs, Vilar and Bergenstal, 1959.

10. Sternberg and Kleopfer, 1960.

11. Puck, Robinson and Tjio, 1960.

12. Ford, Jones, Polani, de Almeida and Briggs, 1959.

13. Fraaccaro, Kaijser and Lindsten, 1959.

14. Fraaccaro, Kaijser and Lindsten, 1960a.

15. Bahner, Schwarz, Harnden, Jacobs, Hienz and Walter, 1960.

16. Jacobs and Strong, 1959.

17. Bergman, Reitalu, Nowakowski and Lenz, 1960.

18. Nelson, Ferrari and Bottura, 1960.

19. Ford, Jones, Miller, Mittwoch, Penrose, Kidler and Shapiro, 1959.

20. Ford, Polani, Briggs and Bishop, 1959.

21. Crooke and Hayward, 1960.

22. Muldal and Ockey, 1960.

23. Jacobs, Baikie, Court Brown, MacGregor, Maclean and Harnden, 1959.

24. Fraser, Campbell, MacGillivray, Boyd and Loums, 1960.

25. Stewart and Sanderson, 1960.

26. Jacobs, Harnden, Court Brown, Goldstein, Close, Mac-

Gregor, Maclean and Strong, 1960.

27. Ferguson-Smith, Johnston and Handmaker, 1960.
28. Böök and Santesson, 1960.
29. Harden and Armstrong, 1959.
30. Hungerford, Donnelly, Nowell and Beck, 1959.
31. Ferguson-Smith, Johnston and Weinberg, 1960.
32. deAssis, Epps, Bottura and Ferrari, 1960.
33. Gordon, O'Gorman, Dewhurst and Blank, 1960
34. Hirschhorn, Decker and Cooper, 1960.
35. Sasaki and Makino, 1960.

36. Bloise, Bottura, deAssis, and Ferrari, 1960.
37. Fraccaro, Kaijser and Lindsten, 1960c.
- 37a. Fraccaro and Lindsten, 1960.
38. Fraccaro, Ikkos, Lindsten, Luft and Kaijser, 1960.
39. Harden, 1960.
40. Ferguson-Smith and Johnston, 1960.
41. Sandberg, Koepf, Crosswhite and Hauslicka, 1960.
42. Hayward, 1960.

it should be remembered that they were sought in institutions for which this is a criterion of admittance. Their mental ability was distinctly less than that of Klinefelter XXY cases which have come under study. The pattern of the XXXY effects on the reproductive tract, however, was comparable with that observed in the XXY genotypes. The effects of one Y chromosome were balanced by either two or three X chromosomes to give nearly equal phenotypic effects.

#### 9. XXY + 66 Autosome Type

XXY + 66 autosome type was established by Böök and Santesson (1960) for an infant boy having several somatic anomalies which may or may not be relevant to the sex type. Externally the genitalia were normal for a male of his age, penis and scrotum with testes present in the scrotum. Again the Y chromosome demonstrates its male potencies over two X's even in the presence of three sets of autosomes. The case is of particular significance since further development may indicate what male potencies an extra set of autosomes may possess.

#### 10. Summary of Types

Other types of sex modifying chromosomal combinations and their contained genes have been observed particularly as mosaics or as chromosomal fragments added or subtracted from the normal genomes. No doubt other types will be discovered during the mushroom growth of this period. Time can only test the soundness of the observations for the field of human chromosomal genetics and cytology is difficult at best requiring special aptitudes and experience. Mistakes, no doubt, will be made. The status of the subject is summarized in Table 1.5.

#### 11. Types Unrelated to Sex

Other cases not related to sex or only secondarily so were scrutinized during the

course of these studies. The information gained from them is valuable as it strengthens our respect for the mechanisms involved. The sex types which are dependent on loss or gain of the X and/or Y chromosomes belong to the larger category of monosomies or trisomies. Numbers of autosomal monosomic and trisomic syndromes have also been identified in the course of these investigations. Similarly, not all cases that have been studied have turned out to be associated with chromosomal changes. This in itself is important since it lends confidence in those that have, as well as redirects research effort toward the search for other causes than chromosomal misbehavior. The first trisomic in man was identified through the study of Mongolism. The condition affects a number of primary characteristics but not those of sex, for males and females occur in about equal numbers. The broad spectrum of these effects points to a loss of balance for an equally extensive group of genes in the two sexes. The common association of characteristics making up these Mongoloids, together with their sporadic appearance and their change in frequency with maternal age, all suggest the findings which Lejeune, Gautier and Turpin (1959a, b) and Lejeune, Turpin and Gautier (1959a, b) were able to demonstrate so successfully. They established that the tissue culture cells of Mongoloid imbeciles had 47 chromosomes and that the extra chromosome was in the small acrocentric group. Lejeune, Gautier and Turpin (1959a, b) have now confirmed these observations on not less than nine cases. Jacobs, Baikie, Court Brown and Strong (1959), Böök, Fraccaro and Lindsten (1959) and Fraccaro (cited by Ford, 1960) as well as later observers have substantiated the results on more than ten other cases. The well known maternal age effect, whereby women over 40 have a chance of having Mongoloid offspring 10 to 40 times as frequently as those of the younger ages, would seem to point to non-

disjunction in oogenesis as the most important cause of this condition. Some women who have had previous Mongoloid progeny have an increased risk of having others. This is an important consideration in that genetic factors may materially assist in bringing about nondisjunction in man as they are known to do in *Drosophila* (Gowen and Gowen, 1922; Gowen, 1928). The products of the nondisjunctions approach those expected on random distribution of the chromosomes (Gowen, 1933) so that occasionally more than one type of chromosome disjunction will appear in a given individual. Such a case is that illustrated by Ford, Jones, Miller, Mittwoch, Penrose, Ridler and Shapiro (1959) in which the nondisjunctional type included not only that for the chromosome important to Mongolism but also the sex chromosomes significant in determining the Klinefelter condition. This individual showed 48 chromosomes, 22 pairs of normal autosomes, 3 sex chromosomes XXY, and a small acrocentric chromosome matching a pair of chromosomes, the 21st, within the smallest chromosomes of the human idiogram. The analysis of Mongolism showed the way for the separation of the various human sex types through chromosome analyses.

Chromosome translocations furnish another means of establishing an anomaly that may then continue on an hereditary basis as either the male or female may transmit the rearranged chromosomes. Polani, Briggs, Ford, Clarke and Berg (1960), Fraaccaro, Kujser and Lindsten (1960b), Penrose, Ellis and Delhanty (1960) and Carter, Hamerton, Polani, Gunalp and Weller (1960) have studied Mongoloid cases which they interpreted in this manner. In some cases the rearranged chromosomes have been transmitted for three generations. Several of the translocations were considered to include chromosomes 15 and 21.

Another trisomic autosomal type was reported by Patau, Smith, Therman, Inhorn and Wagner (1960). The patient was female and had 47 chromosomes. The extra chromosome was a medium-sized acrocentric autosome belonging to the D group. Despite extensive malformations affecting several organs the patient lived more than a year. Another female portraying the same

syndrome has since been found, so other cases may be expected. Among the characteristics are mental retardation, minor motor seizures, deafness, apparent micro or anophthalmia, horizontal palmar creases, trigger thumbs, polydactyly, cleft palate, and hemangiomas.

The third trisomic type was also reported by Patau, Smith, Therman, Inhorn and Wagner (1960). Six individuals have been observed. The characters affected are mental retardation, hypertonicity (5 patients), small mandible, malformed ears, flexion of fingers, index finger overlaps third, big toe dorsiflexed (at least 4), hernia and/or diaphragm eventration, heart anomaly (at least 4), and renal anomaly (3). The sexes were two males and four females. The extra chromosome was in the E group and was diagnosed as number 18. Edwards, Harnden, Cameron, Crosse and Wolff (1960) have described a similar case but they consider the trisomic to be number 17. Ultimate comparisons of these types no doubt will decide if this is a 4th trisomic or if all the cases belong in the same group.

The Sturge-Weber syndrome apparently is caused by another trisomic. Locomotor and mental abilities are retarded. Hayward and Bower (1960) interpret the 3 chromosomes responsible as the smallest autosomes, number 22, of the human group.

Trisomic frequencies should be matched by equal numbers of monosomies. Turpin, Lejeune, Lafoucade and Gautier (1959) have reported polydyspondylism in a child with low intelligence, dwarfing, and multiple malformations of spine and sella turcica. The somatic cell chromosome count was only 45 but one of the smallest acrocentric chromosomes appeared to have been translocated, the greatest part of this chromosome being observed on the short arm of one of the 3 longer acrocentric chromosomes. The condition appears to be unique and not likely to be found in other unrelated families. However, the phenotypic effects were so severe that all members of the proband's family would seemingly be worthy of careful survey for their chromosome characteristics.

The complex pattern of multiple anomalies renders each syndrome distinct from the others. Chromosome losses or gains from

the normal diploid would be expected to lead to the complex changes. Mongolism is influenced by age of the mother and probably to some extent by her inheritance. It is to be expected that the other trisomies may show parallel relations. Other trisomies may be expected although, as the chromosomes increase in size, a group of them will have less opportunity to survive because of loss of balance with the rest of the diploid set. Thus far most of these conditions affect the sex phenotypes. This is in accord with the results in *Drosophila*. Changes in the balance of the X chromosomes are less often lethal than the gain or loss of an autosome. Other animals show like effects. In plants, loss or gain of a chromosome, although generally detrimental, often causes less severe restrictions on life. Harmful effects are observed but do not cause early deaths. This may be because many aneuploids are within what are presumably polyploid plant species.

Ford (1960) has collected the data on 13 different phenotypes that could come under suspicion of chromosomal etiology as examined by a number of workers. Careful cytologic examination of patients suffering from one or another of these diseases has shown that the idiograms were normal in both number and structure of the chromosomes. The disease conditions were: acrocephalosyndactyly, arachnodactyly (Marfan's syndrome), chondrodystrophy, Crouzon's disease, epiloia, gargoylism, Gaucher's disease, hypopituitary dwarfism, juvenile amaurotic idiocy, Laurence-Moon-Biedl syndrome, Little's disease, osteogenesis imperfecta, phenylketonuria, and anencephalic types. To this list Sandberg, Koepf, Crosswhite and Hausehka (1960) have now been added neurofibromatosis, Lowe's syndrome, and pseudohypoparathyroidism.

#### F. SEX RATIO IN MAN

Sex ratio studies on human and other animal populations have always been large in volume. The period since 1938 is no exception. Geissler's (1889) data on family sex ratios, containing more than four million births, have been reviewed and questions raised by several later analysts. Edwards (1958) has reanalyzed the data from this population and considered these points and

reviewed the problems in the light of the following questions: (1) Does the sex ratio vary between families of the same size? (2) Do parents capable of producing only unisexual families exist? (3) Can the residual deviations in the data be satisfactorily explained? Probability analyses were based on Skellam's modified binomial distribution, a special case of the hypergeometrical. The following conclusions were drawn. The probability of a birth being male varies between families of the same size among a complete cross-section of this 19th century German population. There is no evidence for the existence of parents capable of producing only unisexual families. With the assumption that proportions of males vary within families, the apparent anomalies in the data appear to be explicable. These studies have a bearing on the variances observed in further work dealing with family differences such as that of Cohen and Glass (1959) on the relation of ABO blood groups to the sex ratio and that of Novitski and Kimball (1958) on birth order, parental age, and sex of offspring. Novitski and Kimball's data are of basic significance, for the interpretations are based on a large volume of material covering a one-year period in which improved statistical techniques were utilized in the data collection, in showing that within these data sex ratio variation showed relatively little dependence on age of mother, whereas it did show dependence on age of father, birth order, and interactions between them. These observations have direct bearing on the larger geographic differences observed in sex ratios as discussed by Russell (1936) and have recently been brought to the fore through the studies of Kang and Cho (1959a, b). If these data stand the tests for biases, they are of significance in showing Korea to have one of the highest secondary sex ratios of any region, 113.5 males to 100 females, as contrasted with the American ratio of about 106 males to 100 females. Of similar interest is the lower rate of twin births, 0.7 per cent in Korea vs. about 1 per cent in Caucasian populations and the fact that nearly two-thirds of these twin births in Korean peoples are identical, whereas those in the Caucasian groups are only about half that number. The reasons for these differences must

lie in the relations of the human X and Y chromosomes and autosomes and the balance of their contained genes. Little or nothing is known about how these factors operate in the given situations.

**ACKNOWLEDGMENT.** In formulating and organizing the material on which this paper is based I have been fortunate in the helpful discussions and analytical advice contributed so generously by Doctors H. L. Carson, K. W. Cooper, H. V. Crouse, C. W. Metz, S. B. Pipkin, W. C. Rothenbuhler, and H. D. Stalker, and others having primary research interests in this field. To them, and particularly to my research associates Doctors S. T. C. Fung and Janice Stadler, our secretary Gladys M. Dicke and to my wife, Marie S. Gowen, I tender grateful acknowledgment for their contributions to the manuscript. Direct reference is made to some 300 investigations in the body of the paper but the actual number, many of which could equally well have been incorporated, that furnished background to these advances is much larger, more than 1600. To this vast effort toward understanding the foundations for sex we are all indebted.

## XI. References

- AIDA, T. 1921. On the inheritance of color in a fresh-water fish *Aplocheilichthys latipes* (Temmick and Schlegel), with special reference to sex-linked inheritance. *Genetics*, **6**, 554-573.
- AIDA, T. 1936. Sex reversal in *Aplocheilichthys latipes* and a new explanation of sex differentiation. *Genetics*, **21**, 136-153.
- ANDERSSON, T. 1956. Intersexuality in pigs. *Kungl. Skogs-och Lantbruksakad. tidskrift Arg.*, **95**, 257-262.
- ANDRES, A. H., AND NAVASHEIN, M. S. 1936. Morphological analysis of human chromosomes. *Proc. Maxim Gorky Med. Genet. Res. Inst., Moscow*, **4**, 506-524.
- ARONSON, M. M. 1959. New evidence for genetic activity of the Y chromosome in *D. melanogaster*. *Records Genet. Soc. Am.*, **28**, 59.
- ASDELL, S. A. 1936. Hermaphroditism in goats. *Dairy Goat J.*, **14**, 3-4.
- BAIENER, F., SCHWARZ, G., HARNDEN, D. G., JACOBS, P. A., HIENZ, H. A., AND WALTER, K. 1960. A fertile female with XO sex chromosome constitution. *Lancet*, **2**, 100-101 (7141).
- BAKER, W. K. 1956. Chromosome segregation in *D. viridis* males with multiple sex chromosomes. *Genetics*, **41**, 907-911.
- BAKER, W. K., AND SPOFFORD, J. B. 1959. Heterochromatic control of position-effect variegation in *Drosophila*. *Biol. Contr., Univ. Texas Publ.*, **5914**, 135-151.
- BALTZER, F. 1935. Experiments on sex-development in *Bonellia*. *The Collecting Net*, **10**, 3-8.
- BAMBER, R. C., AND HERDMAN, E. C. 1932. A report on the progeny of a tortoiseshell male cat, together with a discussion of his gametic constitution. *J. Genet.*, **26**, 115-128.
- BARR, M. L. 1959. Sex chromatin and phenotype in man. *Science*, **130**, 679-685.
- BARR, M. L., AND BERTRAM, E. G. 1949. A morphological distinction between neurones of the male and female, and the behavior of the nucleolar satellite during accelerated nucleoprotein synthesis. *Nature, London*, **163**, 676-677.
- BEADLE, G. W. 1930. Genetical and cytological studies of Mendelian asynapsis in *Zea mays*. *Cornell Univ. Agric. Exper. Sta.*, **129**, 3-23.
- BEADLE, G. W., AND EPHRUSSI, B. 1937. Ovary transplants in *Drosophila melanogaster*: meiosis and crossing over in superfemales. *Proc. Nat. Acad. Sc.*, **23**, 356-360.
- BEERMANN, W. 1956. Nuclear differentiation and functional morphology of chromosomes. *Cold Spring Harbor Symposia Quant. Biol.*, **21**, 217-232.
- BELLAMY, A. W., AND QUEAL, M. L. 1951. Heterosomal inheritance and sex determination in *Platylococcus maculatus*. *Genetics*, **36**, 93-107.
- BEMIS, W. P., AND WILSON, G. B. 1953. A new hypothesis explaining the genetics of sex determination in *Spinacia oleracea* L. *J. Hered.*, **44**, 91-95.
- BENDER, M. A. 1957. X-ray induced chromosome aberrations in normal human tissue cultures. *Science*, **126**, 974-975.
- BERG, R. L. 1937. The relative frequency of mutations in different chromosomes of *Drosophila melanogaster*. II. Sterility mutations. *Genetics*, **22**, 241-248.
- BERGMAN, S., REITALU, J., NOWAKOWSKI, H., AND LENZ, W. 1960. The chromosomes in two patients with Klinefelter syndrome. *Ann. Human Genet.*, **24**, 81-88.
- BERRY, R. O. 1941. Chromosome behavior in the germ cells and development of the gonads in *Sciara ocellaris*. *J. Morphol.*, **68**, 547-576.
- BLAKESLEE, A. F. 1901. Sexual reproduction in the mucorineae. *Proc. Am. Acad. Sc.*, **40**, 203-322.
- BLOISE, W., BOTTURA, C., DE ASSIS, L. M., AND FERRARI, I. 1960. Gonadal dysgenesis (Turner's syndrome) with male phenotype and XO chromosomal constitution. *Lancet*, **2**, 1059-60 (7159).
- BÖÖK, J. A., FRACCARO, M., AND LINDSTEN, J. 1959. Cytogenetical observations in Mongolism. *Acta Paediatr.*, **48**, 153-168.
- BÖÖK, J. A., AND SANTESSON, B. 1960. Malformation syndrome in man associated with triploidy (69 chromosomes). *Lancet*, **1**, 868 (7129).
- BOSTIAN, C. H. 1939. Multiple alleles and sex

- determination in *Habrobracon*. *Genetics*, **24**, 770-776.
- BREIDER, H. 1942. ZW-Männchen und WW-Weibchen bei *Platypoecilus maculatus*. *Biol. Zentrabl.*, **62**, 183-195.
- BRIDGES, C. B. 1916. Non-disjunction as proof of the chromosome theory of heredity. *Genetics*, **1**, 1-52; 107-163.
- BRIDGES, C. B. 1921. Triploid intersexes in *Drosophila melanogaster*. *Science*, **54**, 252-254.
- BRIDGES, C. B. 1922. The origin of variations in sexual and sex-limited characters. *Am. Naturalist*, **56**, 51-63.
- BRIDGES, C. B. 1932. The genetics of sex in *Drosophila*. In *Sex and Internal Secretions*, 1st ed., E. Allen, Ed., pp. 55-93. Baltimore: The Williams & Wilkins Company.
- BRIDGES, C. B. 1939. Cytological and genetic basis of sex. In *Sex and Internal Secretions*, 2nd ed., E. Allen, C. H. Dantorth, and E. A. Doisy, Eds., pp. 15-63. Baltimore: The Williams & Wilkins Company.
- BRIDGES, C. B., AND BREIDME, K. S. 1944. The mutants of *Drosophila melanogaster*. *Carnegie Inst. Washington Publ.*, **552**, 1-257.
- BROSSEAU, G. E., JR. 1960. Genetic analysis of the male fertility factors on the Y chromosome of *Drosophila melanogaster*. *Genetics*, **45**, 257-274.
- BURDETTE, W. J. 1940. The effect of artificially produced tetraploid regions of the chromosomes of *Drosophila melanogaster*. *Univ. Texas Publ.*, **4032**, 157-163.
- BUZZATI-TRAVERSO, A. 1941. An extreme case of sex-ratio in *D. bilineata*. *Drosophila Information Service*, **14**, 49.
- CARSON, H. L. 1956. A female-producing strain of *D. borealis* Patterson. *Drosophila Information Service*, **30**, 109-110.
- CARSON, H. L., WHEELER, M. R., AND HEED, W. B. 1957. A parthenogenetic strain of *D. mangabai* Malogolowkin. *Univ. Texas Publ.*, **5721**, 115-122.
- CARTER, C. O., HAMERTON, J. L., POLANI, P. E., GUNALP, A., AND WELLER, S. D. V. 1960. Chromosome translocation as a cause of familial mongolism. *Lancet*, **2**, 678-680 (7152).
- CAVALCANTI, A. G. L., AND FALCÃO, D. N. 1954. A new type of sex-ratio in *Drosophila prosaltans* Duda. In *Proceedings 5th International Congress Genetics*, Part II, pp. 1233-1235. (Caryologia, Vol. VI. Suppl.)
- CHANG, C. Y., AND WITSCHI, E. 1955. Breeding of sex-reversed males of *Xenopus laevis* Daudin. *Proc. Soc. Exper. Biol. & Med.*, **89**, 150-152.
- CHANG, C. Y., AND WITSCHI, E. 1956. Genetic control and hormonal reversal of sex differentiation in *Xenopus*. *Proc. Soc. Exper. Biol. & Med.*, **93**, 140-144.
- CHU, E. H. Y., AND GILES, N. H. 1959. Human chromosome complements in normal somatic cells in culture. *Am. J. Human Genet.*, **11**, 63-79.
- COHEN, B. H., AND GLASS, B. 1959. Further observations on the ABO blood groups and the sex ratio. *Am. J. Human Genet.*, **11**, 274-278.
- COLE, L. J., AND HOLLANDER, W. F. 1950. Hybrids of pigeon by ringdove. *Am. Naturalist*, **84**, 275-308.
- COOPER, K. W. 1952. Studies on spermatogenesis in *Drosophila*. *Am. Philos. Soc. Yrbk.*, **1951**, 146-147.
- COOPER, K. W. 1956. Phenotypic effects of Y chromosome hyperploidy in *Drosophila melanogaster*, and their relation to variegation. *Genetics*, **41**, 242-264.
- COOPER, K. W. 1959. Cytogenetic analysis of major heterogametic elements (especially Xh and Y) in *Drosophila melanogaster* and the theory of "heterochromatin." *Chromosoma*, **10**, 535-588.
- CROOKE, A. C., AND HAYWARD, M. D. 1960. Mosaicism in Klinefelter's Syndrome. *Lancet*, **1**, 1198 (7135).
- CROUSE, H. V. 1943. Translocations in *Sciara*; their bearing on chromosome behavior and sex determination. *Missouri Agric. Exper. Sta. Res. Bull.*, **379**, 1-75.
- CROUSE, H. V. 1960a. The nature of the influence of X-translocations on sex of progeny in *Sciara coprophila*. *Chromosoma*, **11**, 146-166.
- CROUSE, H. V. 1960b. The controlling element in sex chromosome behavior in *Sciara*. *Genetics*, **45**, 1429-1443.
- CROW, J. F. 1946. The absence of a primary sex factor on the X chromosome of *Drosophila*. *Am. Naturalist*, **80**, 663-665.
- DANFORTH, C. H. 1932. Genetics of sexual dimorphism in plumage. In *Congress of Genetics, Ithaca*, vol. **2**, pp. 34-36.
- DARLINGTON, C. D., AND JANAKI AMMAL, E. K. 1945. *Chromosome Atlas of Cultivated Plants*. London: George Allen & Unwin, Ltd.
- DARLINGTON, C. D., AND HAQUE, A. 1955. Chromosomes of monkeys and men. *Nature*, London, **175**, 32.
- DE ASSIS, L. M., EPPS, D. R., BOTTURA, C., AND FERRARI, I. 1960. Chromosomal constitution and nuclear sex of a true hermaphrodite. *Lancet*, **2**, 129-130 (7142).
- DEMEREK, M. (Editor). 1950. *Biology of Drosophila*. New York: John Wiley & Sons, Inc.
- DE WINIWARDER, H. 1912. Études sur la spermatogénèse humaine. I. Cellule de Sertoli. II. Hétérochromosome et mitoses de l'épithélium séminal. *Arch. Biol.*, **27**, 91-190.
- DE WINIWARDER, H., AND OGUMA, K. 1926. Nouvelles recherches sur la spermatogénèse humaine. *Arch. Biol.*, **36**, 99-166.
- DOBZHANSKY, T., AND BRIDGES, C. B. 1928. The reproductive system of triploid intersexes in *Drosophila melanogaster*. *Am. Naturalist*, **62**, 425-434.
- DOBZHANSKY, T., AND HOLZ, A. M. 1943. A re-examination of the problem of manifold effects of genes in *Drosophila melanogaster*. *Genetics*, **28**, 295-303.
- DOBZHANSKY, T., AND SCHULTZ, J. 1934. The distribution of sex-factors in the X chromo-

- some of *Drosophila melanogaster*. *J. Genet.*, **23**, 319-386.
- DOBZHANSKY, T., AND SPASSKY, B. 1941. Intersexes in *Drosophila pseudoobscura*. *Proc. Nat. Acad. Sc.*, **27**, 556-562.
- DRESSLER, O. 1958. Zytogenetische Untersuchungen an diploidem und polyploidem spinat (*Spinacia oleracea* L.) unter besonderer Berücksichtigung der Geschlechtsvererbung als Grundlage einer Inzucht-Heterosis-Züchtung. *Ztschr. Pflanzenzücht.*, **40**, 385-424.
- DUBOIS, A. M. 1932. A contribution to the embryology of *Sciara* (Diptera). *J. Morphol.*, **54**, 161-195.
- EATON, O. N. 1943. An anatomical study of hermaphroditism in goats. *Am. J. Vet. Res.*, **4**, 333-343.
- EATON, O. N. 1945. The relation between polled and hermaphroditic characters in dairy goats. *Genetics*, **30**, 51-61.
- EDITORIAL. 1960. A proposed standard system of nomenclature of human mitotic chromosomes. *Lancet*, **1**, 1063-1065 (7133).
- EDWARDS, A. W. F. 1958. An analysis of Geissler's data on the human sex ratio. *Ann. Human Genet.*, **23**, 6-15.
- EDWARDS, J. H., HAMDEN, D. G., CAMERON, A. H., CROSSE, M., AND WOLFF, O. H. 1960. A new trisomic syndrome. *Lancet*, **1**, 787-790 (7128).
- ELLIOTT, G. A., SANDLER, A., AND RABINOWITZ, D. 1959. Gonadal dysgenesis in three sisters. *J. Clin. Endocrinol.*, **19**, 995.
- ESSER, K., AND STRAUB, J. 1958. Genetische Untersuchungen an *Sordaria mucospora* AUCRSW. Kompensation und Induktion bei gebundenen Entwicklungsdefekten. *Ztschr. indukt. Abstammungs. Vererb.*, **89**, 729-746.
- EVANS, H. M., AND SWEZEY, O. 1929. The chromosomes in man. *Med. Univ. California*, **9**, 1-41.
- FANKHAUSER, G., AND HUMPHREY, R. R. 1959. The origin of spontaneous heteroploids in the progeny of diploid, triploid, and tetraploid axolotl females. *J. Exper. Zool.*, **142**, 379-422.
- FERGUSON-SMITH, M. A. 1960. Cytogenetics in man. *Arch. Int. Med.*, **105**, 627-639.
- FERGUSON-SMITH, M. A., AND JOHNSTON, A. W. 1960. Chromosome abnormalities in certain diseases of man. *Ann. Int. Med.*, **53**, 359-71.
- FERGUSON-SMITH, M. A., JOHNSTON, A. W., AND HANDMAKER, S. D. 1960. Primary amentia and micro-orchidism associated with an XXXY sex chromosome constitution. *Lancet*, **2**, 184-187 (7113).
- FERGUSON-SMITH, M. A., JOHNSTON, A. W., AND WEINBERG, A. R. 1960. The chromosome complement in true hermaphroditism. *Lancet*, **2**, 126-128 (7142).
- FORD, C. E. 1960. Human cytogenetics: its present place and future possibilities. *Am. J. Human Genet.*, **12**, 101-117.
- FORD, C. E., AND HAMILTON, J. L. 1956. The chromosomes of man. *Nature*, London, **178**, 1020-1023.
- FORD, C. E., JACOBS, P. A., AND LATHA, L. G. 1958. Human somatic chromosomes. *Nature*, London, **181**, 1565-1568.
- FORD, C. E., JONES, K. W., MILLER, O. J., MITTWOCH, U., PENROSE, L. S., RÜDLER, M., AND SHAPIRO, A. 1959. The chromosomes in a patient showing both mongolism and the Klinefelter syndrome. *Lancet*, **1**, 709-710 (7075).
- FORD, C. E., JONES, K. W., POLANI, P. E., DE ALMEIDA, J. C., AND BRIGGS, J. H. 1959. A sex-chromosome anomaly in a case of gonadal dysgenesis (Turner's syndrome). *Lancet*, **1**, 711-713 (7075).
- FORD, C. E., POLANI, P. E., BRIGGS, J. H., AND BISHOP, P. M. F. 1959. A presumptive human XXY/XX mosaic. *Nature*, London, **183**, 1030-1032.
- FRACCARO, M., IKKOS, D., LINDSTEN, J., LUFT, R., AND KALJSER, K. 1960. A new type of chromosomal abnormality in gonadal dysgenesis. *Lancet*, **2**, 1144 (7160).
- FRACCARO, M., KALJSER, K., AND LINDSTEN, J. 1959. Chromosome complement in gonadal dysgenesis (Turner's syndrome). *Lancet*, **1**, 886 (7078).
- FRACCARO, M., KALJSER, K., AND LINDSTEN, J. 1960a. Somatic chromosome complement in continuously cultured cells of two individuals with gonadal dysgenesis. *Ann. Human Genet.*, **24**, 45-61.
- FRACCARO, M., KALJSER, K., AND LINDSTEN, J. 1960b. Chromosomal abnormalities in father and Mongol child. *Lancet*, **1**, 724-727 (7127).
- FRACCARO, M., KALJSER, K., AND LINDSTEN, J. 1960c. A child with 49 chromosomes. *Lancet*, **2**, 899-901 (7156).
- FRACCARO, M., AND LINDSTEN, M. 1960. A child with 49 chromosomes. *Lancet*, **2**, 1303 (7163).
- FRASER, J. H., CAMPBELL, J., MACGILLIVRAY, R. C., BOYD, E., AND LENNON, B. 1960. The XXX syndrome frequency among mental defectives and fertility. *Lancet*, **2**, 626-627 (7151).
- FROST, J. N. 1960. The occurrence of partially fertile triploid metafemales in *Drosophila melanogaster*. *Proc. Nat. Acad. Sc.*, **46**, 47-51.
- FUNG, S. T. C., AND GOWEN, J. W. 1957a. The developmental effect of a sex-limited gene in *Drosophila melanogaster*. *J. Exper. Zool.*, **134**, 515-532.
- FUNG, S. T. C., AND GOWEN, J. W. 1957b. Pigment-inducing potentialities of testes, ovaries and hermaphroditic (Hr) gonads. *J. Exper. Zool.*, **135**, 5-18.
- FUNG, S. T., AND GOWEN, J. W. 1960. Role of autosome IV in *Drosophila melanogaster* sex balance. *Rec. Genet. Soc. Am.*, **29**, 70-71.
- GALLIEN, L. 1954. Inversion expérimentale du sexe, sous l'action des hormones sexuelles, chez le triton *Pleurodeles waltlii* Michx. Analyse des conséquences génétiques. *Bull. Biol. France et Belgique*, **88**, 1-51.
- GALLIEN, L. 1955. Descendance unisexuée d'une femelle de *Xenopus laevis* Daud. ayant subi, pendant sa phase larvaire, l'action gynogénèse



- du benzoate d'oestradiol. *Compt. rend. Acad. Sc.*, **240**, 913-915.
- GALLEN, L. 1956. Inversion experimentale du sexe chez un Anoure inférieur *Xenopus laevis* Daudin. *Bull. Biol. France et Belgique*, **90**, 163-183.
- GEISSLER, A. 1889. Beiträge zur Frage des Geschlechtsverhältnisses der Zeburen. *Ztschr. Sachsischen Statist. Bureau's*, **35**, 1-24.
- GERSHENSON, S. 1928. A new sex ratio abnormality in *Drosophila obscura*. *Genetics*, **13**, 488-507.
- GOLDSCHMIDT, R. B. 1934. *Lymantria*. *Bibl. Genet.*, **11**, 1-186.
- GOLDSCHMIDT, R. B. 1948. New facts on sex determination in *Drosophila melanogaster*. *Proc. Nat. Acad. Sc.*, **34**, 245-252.
- GOLDSCHMIDT, R. B. 1949. The Beaded Minute-intersexes in *Drosophila melanogaster* Meig. *J. Exper. Zool.*, **112**, 233-301.
- GOLDSCHMIDT, R. B. 1951. The maternal effect in the production of the Bd-M-intersexes in *Drosophila melanogaster*. *J. Exper. Zool.*, **117**, 75-110.
- GOLDSCHMIDT, R. B. 1955. *Theoretical Genetics*. Berkeley: University of California Press.
- GOLDSCHMIDT, R. B. 1957. A remarkable action of the mutant "rudimentary" in *Drosophila melanogaster*. *Proc. Nat. Acad. Sc.*, **43**, 731-736.
- GOLDSCHMIDT, R. B., AND KATSUKI, K. 1927. Erbllicher Gynandromorphismus und somatische Mosaikbildung bei *Bombyx mori*. *Biol. Zentrabl.*, **47**, 45-54.
- GOLDSCHMIDT, R. B., AND KATSUKI, K. 1928. Cytologie des erblichen Gynandromorphismus von *Bombyx mori* L. *Biol. Zentrabl.*, **48**, 685-699.
- GOLDSCHMIDT, R. B., AND KATSUKI, K. 1931. Vierte Mitteilung über erblichen Gynandromorphismus und somatische Mosaikbildung bei *Bombyx mori* L. *Biol. Zentrabl.*, **51**, 58-74.
- GOORICH, H. B. 1916. The germ-cells in *Ascaris incruca*. *J. Exper. Zool.*, **21**, 61-100.
- GORDON, M. 1946. Interchanging genetic mechanisms for sex determination in fishes under domestication. *J. Hered.*, **37**, 307-320.
- GORDON, M. 1947. Genetics of *Platylocilus maculatus*. IV. The sex determining mechanism in two wild populations of the Mexican platyfish. *Genetics*, **32**, 8-17.
- GORDON, R. R., O'GORMAN, F. J. P., DEWILURST, C. J., AND BLANK, C. E. 1960. Chromosome count in a hermaphrodite with some features of Klinefelter's syndrome. *Lancet*, **2**, 736-739 (7153).
- GOWEN, J. W. 1928. On the mechanism of chromosome behavior in male and female *Drosophila*. *Proc. Nat. Acad. Sc.*, **14**, 475-477.
- GOWEN, J. W. 1933. Meiosis as a genetic character in *Drosophila melanogaster*. *J. Exper. Zool.*, **65**, 83-106.
- GOWEN, J. W. 1942. On the genetic basis for hermaphroditism. *Anat. Rec.*, **84**, 458 (Abst.).
- GOWEN, J. W. 1947. Sex determination in *Drosophila melanogaster*. *Rec. Genet. Soc. Am.*, **16**, 33 (Abst.).
- GOWEN, J. W., AND FUNG, S. T. C. 1957. Determination of sex through genes in a major sex locus in *Drosophila melanogaster*. *Heredity*, **11**, 397-402.
- GOWEN, J. W., AND GAY, E. H. 1933. Eversporting as a function of the Y chromosome in *Drosophila melanogaster*. *Proc. Nat. Acad. Sc.*, **19**, 122-126.
- GOWEN, M. S., AND GOWEN, J. W. 1922. Complete linkage in *Drosophila melanogaster*. *Am. Naturalist*, **56**, 286-288.
- GOWEN, J. W., AND NELSON, R. H. 1942. Pre-determination of sex. *Science*, **96**, 558-559.
- GRUMBACH, M. M., AND BARR, M. L. 1958. Cytologic tests of chromosomal sex in relation to sexual anomalies in man. *Recent Progr. Hormone Res.*, **14**, 255-324.
- HACHINOHE, Y., AND ONISHI, N. 1952. On the meiosis of the drone of Honey bee *Apis mellifica* L. *Bull. Nat. Inst. Agric. Sc. (Japan)*, **(C)3**, 83-87.
- HAMMOND, J. 1912. A case of hermaphroditism in the pig. *J. Anat. Physiol.*, **46**, 307-312.
- HANNAH, A. M. 1955. The effect of aging the maternal parent upon the sex ratio in *Drosophila melanogaster*. *Ztschr. induct. Abstammungs. Vererb.*, **86**, 574-599.
- HARNDEN, D. G. 1960. Abnormalities of chromosome constitution and defects of sex development. *Proc. Roy. Soc. Med.*, **53**, 493-494.
- HARNDEN, D. G., AND ARMSTRONG, C. N. 1959. Chromosomes of a true hermaphrodite. *Brit. M. J.*, **2**, 1287-1288.
- HARNDEN, D. G., AND STEWART, J. S. S. 1959. Chromosomes in a case of pure gonadal dysgenesis. *Brit. M. J.*, **2**, 1285-1287.
- HARTMANN, M. 1956. Das Wesen und die Grundgesetzlichkeiten des Geschlechts und der Geschlechtsbestimmung im Tier- und Pflanzenreich. In *Die Sexualität*, 2nd ed. Stuttgart: Gustav Fischer.
- HARTMANN, M., AND BAUER, H. 1953. *Allgemeine Biologie*. Stuttgart: Gustav Fischer.
- HASHIMOTO, H. 1929. Some experiments on the mosaics of *Bombyx mori*. *Japan. J. Genet.*, **4(3)**, 113-114.
- HASHIMOTO, H. 1933. Genetical studies on the tetraploid female in the silkworm. I. *Bull. sericult. Exper. Sta. Japan*, **8**, 359-381.
- HASHIMOTO, H. 1934. Genetical studies on the tetraploid female in the silkworm. *Bull. sericult. Exper. Sta. Japan*, **8**, 505-523.
- HAYWARD, M. D. 1960. Sex-chromosome mosaicism in man. *Heredity*, **15**, 219-235.
- HAYWARD, M. D., AND BOWER, B. D. 1960. Chromosomal trisomy associated with the Sturge-Weber syndrome. *Lancet*, **2**, 844-846 (7155).
- HENKING, H. 1891. Untersuchungen über die ersten Entwicklungsvorgänge in den Eiern der Insekten II. Über spermatogenese und deren Beziehung zur Entwicklung bei *Pyrthocoris apterus* M. *Ztschr. wiss. Zool.*, **51**, 685-736.
- HINTON, C. W. 1959. A cytological study of w chromosome instability in cleavage mitoses.

- Deosiphila melanogaster*. *Genetics*, **44**, 923-933.
- HIRSCHTHORN, K., DECKER, W. H., AND COOPER, H. L. 1960. True hermaphroditism with XY/XO mosaicism. *Lancet*, **2**, 319-320 (7145).
- HOFFENBERG, R., JACKSON, W. P. U., AND MULLER, W. H. 1957. Gonadal dysgenesis with menstruation. *J. Clin. Endocrinol.*, **17**, 902-907.
- HOLLANDER, W. F. 1914. Mosaic effects in domestic birds. *Quart. Rev. Biol.*, **19**, 285-307.
- HOLLANDER, W. F., AND GOWEN, J. W. 1959. A single-gene antagonism between mother and fetus in the mouse. *Proc. Soc. Exper. Biol. & Med.*, **101**, 125-128.
- HOLLANDER, W. F., GOWEN, J. W., AND STADLER, J. 1956. A study of 25 gynandromorphic mice of the Bagg albino strain. *Anat. Rec.*, **124**, 223-244.
- Hsu, T. C. 1952. Mammalian chromosomes in vitro. I. The karyotype of man. *J. Heredity*, **43**, 167-172.
- Hsu, T. C., POMERAT, C. M., AND MOORHEAD, P. S. 1957. Mammalian chromosomes in vitro. VIII. Heteroploid transformation in human cell strain Mayes. *J. Nat. Cancer Inst.*, **19**, 867-873.
- HUGHES, W. 1929. The freemartin condition in swine. *Anat. Rec.*, **41**, 213-247.
- HUMPHREY, R. R. 1945. Sex determination in ambystomid salamanders: a study of the progeny of females experimentally converted into males. *Am. J. Anat.*, **76**, 33-66.
- HUMPHREY, R. R., AND FANKHAUSER, G. 1956. Structure and functional capacity of the ovaries of higher polyploid (4N, 5N) in the Mexican axolotl (*Axolotl* or *Ambystoma mexicanum*). *J. Morphol.*, **98**, 161-198.
- HUNGERFORD, D. A., DONNELLY, A. J., NOWELL, P. C., AND BECK, S. 1959. The chromosome constitution of a human phenotypic intersex. *Am. J. Human Genet.*, **11**, 215-236.
- IRWIN, M. R., AND COLE, L. S. 1936. Immunogenetic studies of species and of species hybrids from the cross of *Columba livia* and *Streptopelia risoria*. *J. Exper. Zool.*, **73**, 309-318.
- ISHIHARA, T. 1956. Cytological studies of tortoiseshell male cats. *Cytologia*, **21**, 391-398.
- JACOBS, P. A., BAIKIE, A. G., COURT BROWN, W. M., FORREST, H. ROY, J. R., STEWART, J. S. S., AND LENNOX, B. 1959. Chromosomal sex in the syndrome of testicular feminisation. *Lancet*, **2**, 591-592 (7103).
- JACOBS, P. A., BAIKIE, A. G., COURT BROWN, W. M., MACGREGOR, T. N., MACLEAN, N., AND HARNDEN, D. G. 1959. Evidence for the existence of the human "super female." *Lancet*, **2**, 423-425 (7100).
- JACOBS, P. A., BAIKIE, A. G., COURT BROWN, W. M., AND STRONG, J. A. 1959. The somatic chromosomes in mongolism. *Lancet*, **1**, 710 (7075).
- JACOBS, P. A., HARNDEN, D. G., COURT BROWN, W. M., GOLDSTEIN, J., CHASE, H. G., MACGREGOR, T. N., MACLEAN, N., AND STRONG, J. A. 1960. Abnormalities involving the X-chromosome in women. *Lancet*, **1**, 1213-1216 (7136).
- JACOBS, P. A., AND STRONG, J. A. 1959. A case of human intersexuality having a possible XXY sex-determining mechanism. *Nature*, London, **183**, 302-303.
- JACOBSEN, P. 1957. The sex chromosomes in *Humulus*. *Hereditas*, **43**, 357-370.
- JANICK, J. 1955. Environmental influences on sex expression in monoecious lines of spinach. *Proc. Am. Soc. Horticult. Sc.*, **65**, 416-422.
- JANICK, J., AND ELLIS, J. R. 1959. Identification of the sex chromosome in *Spinacia oleracea*. (Abst.) *Rec. Genet. Soc. Am.*, **28**, 78.
- JANICK, J., MAHONEY, D. L., AND PFAHLER, P. L. 1959. The trisomies of *Spinacia oleracea*. *J. Hered.*, **50**, 47-50.
- JANICK, J., AND STEVENSON, E. C. 1955a. The effects of polyploidy on sex expression in spinach. *J. Hered.*, **46**, 151-156.
- JANICK, J., AND STEVENSON, E. C. 1955b. Genetics of the monoecious character in spinach. *Genetics*, **40**, 429-437.
- JENNINGS, H. S. 1939. Genetics of *Paramecium bursaria*. I. Mating types and groups, their interrelations and distribution; mating behavior and self sterility. *Genetics*, **24**, 202-233.
- JOHNSTON, E. F., ZELLER, J. H., AND CANTWELL, G. 1958. Sex anomalies in swine. *J. Hered.*, **49**, 255-261.
- KANG, Y. S., AND CHO, W. K. 1959a. Data on the biology of Korean populations. *Human Biol.*, **31**, 244-251.
- KANG, Y. S., AND CHO, W. K. 1959b. The sex ratio at birth of the Korean population. *Eugenics Quart.*, **6**, 187-195.
- KAWAGUCHI, E. 1928. Zytologische Untersuchungen am Seidenspinner und seine Verwandten. I. Gametogenese von *Bombyx mori* L. und *Bombyx mandarina* M. und ihre Bastarde. *Ztschr. Zellforsch.*, **7**, 519-533.
- KELLER, K., AND TANDLER, J. 1916. Über das Verhalten der Eihäute bei der Zwillingsfruchtbarkeit des Rindes. *Wien. tierärztl. Monatschr.*, **3**, 513-526.
- KIHARA, H. 1925. Chromosomes of *Rumex acetosella* L. *Botan. Mag., Tokyo*, **39**, 353-360.
- KIHARA, H., AND ONO, T. 1923. Cytological studies on *Rumex* L. I. Chromosomes of *Rumex acetosa* L. *Botan. Mag., Tokyo*, **37**, 84-91.
- KIHARA, H., AND YAMAMOTO, Y. 1935. Chromosomenverhältnisse bei *Azucuba chinensis* Benth. *Agric. & Horticult., Japan*, **10**, 2185-2196.
- KIMBALL, R. F. 1939. Mating types in *Euplotes*. *Am. Naturalist*, **73**, 451-456.
- KOBAY, M. 1958. The supernumerary chromosome of man. *Am. J. Human Genet.*, **10**, 125-140.
- KOLLER, P. C. 1937. The genetical and mechanical properties of sex chromosomes. III. Man. *Proc. Roy. Soc. Edinburgh*, **57**, 194-214.
- KOMAI, T. 1952. On the origin of the tortoiseshell male cat—a correction. *Proc. Japan Acad., Tokyo*, **28**, 150-155.
- KOMAI, T., AND ISHIHARA, T. 1956. On the origin of the male tortoiseshell cat. *J. Hered.*, **47**, 287-291.

- KONDO, K. 1952. Studies on intersexuality in milk goats. Japan. J. Genet., **27**, 131-141.
- KONDO, K. 1955a. Studies on intersexuality in milk goats. III. On the homozygous recessive males and the methods of eliminating intersexual gene. Bull. Nat. Inst. Agric. Sc., Japan, ser. G, **10**, 107-117.
- KONDO, K. 1955b. The frequency of occurrence of intersexes in milk goats. Japan. J. Genet., **30**, 139-146.
- KRIVSHENKO, J. 1959. New evidence for the homology of the short euchromatic elements of the X and Y chromosomes of *Drosophila busckii* with the microchromosome of *Drosophila melanogaster*. Genetics, **44**, 1027-1040.
- LEBEDEFF, G. A. 1934. Genetics of hermaphroditism in *Drosophila virilis*. Proc. Nat. Acad. Sc., **20**, 613-616.
- LEJEUNE, J., GAUTIER, M., AND TURPIN, R. 1959a. Les chromosomes humains en culture de tissus. Compt. rend. Acad. Sc., **248**, 602-603.
- LEJEUNE, J., GAUTIER, M., AND TURPIN, R. 1959b. Étude des chromosomes somatiques de neuf enfants mongoliens. Compt. rend. Acad. Sc., **248**, 1721-1722.
- LEJEUNE, J., TURPIN, R., AND GAUTIER, M. 1959a. Le mongolisme, premier exemple d'aberration autosomique humaine. Ann. Genet., **2**, 41-49.
- LEJEUNE, J., TURPIN, R., AND GAUTIER, M. 1959b. Le mongolisme, maladie chromosomique (trisomie). Bull. Acad. Nat. Med., **143**, 256-265.
- LEWIS, D. 1942. Evolution of sex in flowering plants. Biol. Rev., Cambridge Phil. Soc., **17**, 46-67.
- L'HERITIER, P. 1951. The CO<sub>2</sub> sensitivity problem in *Drosophila*. Cold Spring Harbor Symposium Quant. Biol., **16**, 99-112.
- L'HERITIER, P. 1955. Les virus intégrés et l'unité cellulaire. Ann. Biol., **31**, 481-496.
- LILLIE, F. R. 1917. The freemartin; a study of the action of sex hormones in the foetal life of cattle. J. Exper. Zool., **23**, 371.
- LÖVE, A. 1944. Cytogenetic studies on *Rumex* subgenus *Acetosella*. Hereditas, **30**, 1-136.
- LÖVE, A. 1957. Sex determination in *Rumex*. Proc. Genet. Soc. Canada, **2**, 31-36.
- LÖVE, A., AND SARKAR, N. 1956. Cytotaxonomy and sex determination of *Rumex paucifolius*. Canad. J. Botany, **34**, 261-268.
- LUBS, H. A., JR., VILAR, O., AND BERGENSTAL, D. M. 1959. Familial male pseudohermaphroditism with labial testes and partial feminization: endocrine studies and genetic aspects. J. Clin. Endocrinol., **19**, 1110-1120.
- MACKENSEN, O. 1951. Viability and sex determination in the honey bee (*Apis mellifera* L.). Genetics, **36**, 500-509.
- MACKENSEN, O. 1955. Further studies on a lethal series in the honey bee. J. Hered., **46**, 72-71.
- MAGNI, G. E. 1952. Sex-ratio in *Drosophila bifasciata*. Ist. Lombardi di Scienze e Lettere, **85**, 391-411.
- MAGNI, G. E. 1953. 'Sex-ratio,' a non-Mendelian character in *Drosophila bifasciata*. Nature, London, **172**, 81.
- MAGNI, G. E. 1954. Thermal cure of cytoplasmic sex-ratio in *Drosophila bifasciata*. In *Proceedings 9th International Congress of Genetics, Bellagio*, pp. 1213-1216.
- MAGNI, G. E. 1957. Analisi della trasmissione delle particelle citoplasmatiche "sex-ratio" in *Drosophila bifasciata*. Atti. 3 Rinn. A.G.I., Ric. Sci. **27**, 67-70. (Suppl.)
- MAKINO, S. 1950. Contribution of the sex chromosome in an intersex goat. A preliminary note. Iden-Sogo-Kenkyu, **1**, 1-3.
- MAKINO, S. 1951. *Chromosome Numbers in Animals*, 2nd ed. Ames: Iowa state College Press.
- MAKINO, S., AND SASAKI, M. 1959. On the chromosome number of man. Proc. Japan. Acad., **35**, 99-104.
- MALOGOLOVKIN, C. 1958. Maternally inherited sex-ratio conditions in *Drosophila willistoni* and *Drosophila paulistorum*. Genetics, **43**, 276-286.
- MALOGOLOVKIN, C., AND POULSON, D. F. 1957. Infective transfer of maternally inherited abnormal sex-ratio in *Drosophila willistoni*. Science, **125**, 32.
- MALOGOLOVKIN, C., POULSON, D. F., AND WRIGHT, E. Y. 1959. Experimental transfer of maternally inherited abnormal sex-ratio in *Drosophila willistoni*. Genetics, **44**, 59-74.
- MAMPELL, K. 1941. Female sterility in interracial hybrids of *Drosophila pseudoobscura*. Proc. Nat. Acad. Sc., **27**, 337-341.
- MCCLUNG, C. E. 1902. The accessory chromosome—sex determinant? Biol. Bull., **3**, 43-84.
- METZ, C. W. 1938. Chromosome behavior, inheritance and sex determination in *Sciara*. Am. Naturalist, **72**, 485-520.
- METZ, C. W. 1959. Chromosome behavior and cell lineage in triploid and mosaic salivary glands of species hybrids in *Sciara*. Chromosoma, **10**, 515-534.
- MINOTCHI, O., AND OHTA, T. 1934. On the number of chromosomes and the type of sex chromosomes in man. Cytologia, **5**, 472-490.
- MITTWOCH, U. 1952. The chromosome complement in a mongolian imbecile. Ann. Eugenics, London, **17**, 37.
- MORGAN, L. V. 1925. Polyploidy in *Drosophila melanogaster* with two attached X chromosomes. Genetics, **10**, 148-178.
- MORGAN, L. V. 1929. Contributions to the genetics of *Drosophila simulans* and *Drosophila melanogaster*. VIII. Composites of *Drosophila melanogaster*. Publ. Carnegie Inst. Washington, **399**, 223-296.
- MORGAN, L. H. 1914. *Heredity and Sex*. 2nd ed. New York: Columbia University Press.
- MORGAN, T. H., AND BRIDGES, C. B. 1919. Contributions to the genetics of *Drosophila melanogaster*. I. The origin of gynandromorphs. Publ. Carnegie Inst. Washington, **278**, 1-122.
- MORGAN, T. H., BRIDGES, C. B., AND STURTEVANT, A. H. 1925. The genetics of *Drosophila*. *Bibliog. Genet.*, **2**, 1-262.
- MORIYAKI, D., AND KITAGAWA, O. 1957. Sex-ratio-J in *Drosophila bifasciata*. I. A preliminary note. Japan. J. Genet., **32**, 208-210.
- MOSES, M. S., AND METZ, C. W. 1928. Evidence

- that the female is responsible for the sex ratio in *Sciara* (Diptera). Proc. Nat. Acad. Sc., **14**, 928-930.
- MULDAL, S., AND OCKEY, C. H. 1960. The "double male," a new chromosome constitution in Klinefelter syndrome. Lancet, **2**, 492 (7148).
- MURBY, W. H., AND CARSON, H. L. 1959. Parthenogenesis in *Drosophila manganabceira* Malog. Am. Naturalist, **93**, 355-363.
- NELSON, L., FERRARI, I., AND BOTTURA, C. 1960. Chromosomal constitution in a case of Klinefelter's syndrome. Lancet, **2**, 319 (7145).
- NEUBAUER, M. E. 1939. A cytogenetic study of the Y chromosome of *Drosophila melanogaster*. J. Genet., **37**, 229-251.
- NEWBY, W. W. 1942. A study of intersexes produced by a dominant mutation in *Drosophila virilis*. Blanco Stock. Univ. Texas Publ., **4228**, 113-145.
- NILSSON, I. M., BERGMAN, S., REITALU, J., AND WALDENSTRÖM, J. 1959. Haemophilia A in a "girl" with male sex-chromatin pattern. Lancet, **2**, 261-266 (7097).
- NOVITSKI, E. 1947. Genetic analysis of an anomalous sex ratio condition in *Drosophila affinis*. Genetics, **32**, 526-531.
- NOVITSKI, E., AND KIMBALL, A. W. 1958. Birth order, parental ages, and sex of offspring. Am. J. Human Genet., **10**, 268-275.
- NOWAKOWSKI, H., LENZ, W., AND PARADA, J. 1959. Diskrepanz zwischen Chromatinbefund und genetischem Geschlecht beim Klinefeltersyndrom. Acta Endocrinol., **30**, 296-320.
- ONO, T. 1920. Further investigations on the cytology of *Rumex VI-VIII*. Botan. Mag., Tokyo, **44**, 168-176.
- ONO, T. 1935. Chromosomen und sexualität von *Rumex acetosa*. Sc. Repts., Tohoku Univ. Biol., ser. IV, **10**, 41-210.
- ONO, T. 1940. Vorkommen der triploiden intersexe bei *Humulus japonicus*. Japan. J. Botan. & Zool., **8**, 1632-1634.
- OVERZIER, CLAUDE. 1955. Hermaphroditismus verus. Acta Endocrinol., **20**, 63-80.
- PAINTER, T. S. 1921. The Y chromosome in mammals. Science, **53**, 503-504.
- PAINTER, T. S. 1923. Studies in mammalian spermatogenesis. II. The spermatogenesis of man. J. Exper. Zool., **37**, 291-331.
- PATAI, K. 1960. The identification of individual chromosomes, especially in man. Am. J. Human Genet., **12**, 250-276.
- PATAI, K., SMITH, D. W., TUERMAN, E., INHORN, S. L., AND WAGNER, H. P. 1960. Multiple congenital anomaly caused by an extra autosome. Lancet, **1**, 790-793 (7128).
- PATTERSON, J. T. 1938. Sex differentiation. Aberrant forms in *Drosophila* and sex differentiation. Am. Naturalist, **72**, 193-206.
- PATTERSON, J. T., STONE, W. S., AND BEBECHEK, S. 1937. Further studies on X chromosome balance in *Drosophila*. Genetics, **22**, 107-126.
- PENROSE, L. S., ELLIS, J. R., AND DELHANTY, J. D. A. 1960. Chromosomal translocations in mongolism and in normal relatives. Lancet, **2**, 109 (7117).
- PIPKIN, S. B. 1940. Multiple sex genes in the X chromosome of *Drosophila melanogaster*. Univ. Texas Publ., **4032**, 126-156.
- PIPKIN, S. B. 1941. Intersex modifying genes in wild strains of *Drosophila melanogaster*. Genetics, **26**, 164-165.
- PIPKIN, S. B. 1942. Intersex modifying genes in wild strains of *Drosophila melanogaster*. Genetics, **27**, 286-298.
- PIPKIN, S. B. 1947. A search for sex genes in the second chromosome of *Drosophila melanogaster* using the triploid method. Genetics, **32**, 592-607.
- PIPKIN, S. B. 1959. Sex balance in *Drosophila melanogaster*: Aneuploidy of short regions of chromosome 3, using the triploid method. Univ. Texas Publ., **5914**, 69-88.
- PIPKIN, S. B. 1960. Sex balance in *Drosophila melanogaster*: Aneuploidy of long regions of chromosome 3, using the triploid method. Genetics, **45**, 1205-1216.
- POLANI, P. E., BISHOP, P. M. F., FERGUSON-SMITH, M. A., LENNOX, B., STEWART, J. S. S., AND PRADER, A. 1958. Colour vision studies and the X chromosome constitution of patients with Klinefelter's syndrome. Nature, London, **182**, 1092-1093.
- POLANI, P. E., BRIGGS, J. H., FORD, C. E., CLARKE, O. M., AND BERG, J. M. 1960. A Mongol girl with 46 chromosomes. Lancet, **1**, 721-724 (7127).
- POLANI, P. E., LESSOF, M. H., AND BISHOP, P. M. F. 1956. Colour-blindness in "ovarian agenesis" (gonadal dysplasia). Lancet, **2**, 118-120 (6931).
- POOLE, H. K., AND OLSEN, M. W. 1958. Incidence of parthenogenetic development in eggs laid by 3 strains of dark Cornish chickens. Proc. Soc. Exper. Biol. & Med., **97**, 477-478.
- POLSON, D. F. 1940. The effects of certain X chromosome deficiencies on the development of *D. melanogaster*. J. Exper. Zool., **83**, 271-326.
- PRICE, J. B., JR. 1949. The location of a sex limited factor,  $X^b$ , in *D. virilis*. Univ. Texas Publ., **4920**, 22-23.
- PECK, T. T. 1958. Genetic studies on somatic mammalian cells in vitro. J. Cell. Physiol. Suppl. **1**, **52**, 287-311.
- PECK, T. T., ROBINSON, A., AND TRIO, J. H. 1960. Familial primary amenorrhea due to testicular feminization: a human gene affecting sex differentiation. Proc. Soc. Exper. Biol. & Med., **103**, 192-196.
- RAPER, J. W. 1960. Control of sex in fungi. Am. J. Botan., **47**, 794-808.
- RASMUSSEN, I. E. 1957. Tentativi di infezione sperimentale con il carattere "sex ratio" in *Drosophila bifasciata*. Atti III Riun. A. Genet. Ital. La Ric. Sc., Suppl., **27**, 71-74.
- RAVIN, A. W. 1960. The origin of bacterial species, genetic recombination and factors limiting it between bacterial populations. Bact. Rev., **24**, 201-221.
- REDFIELD, H. 1926. The maternal inheritance of a sex-limited lethal effect in *Drosophila melanogaster*. Genetics, **11**, 482-502.

- REYNOLDS, J. P. 1938. Sex determination in a bisexual strain of *Sciara coprophila* Lintner. *Genetics*, **23**, 203-220.
- RICK, C. M., AND HANNA, G. C. 1943. Determination of sex in *Asparagus officinalis* L. *Am. J. Bot.*, **30**, 711-714.
- RIS, H., AND KERR, W. E. 1952. Sex determination in the honey-bee. *Evolution*, New York, **6**, 444-445.
- ROTHENBUHLER, W. C. 1955. Hereditary aspects of gynandromorph occurrence in honey bees (*Apis mellifica*). *Iowa State Coll. J. Sc.*, **29**, 487-488.
- ROTHENBUHLER, W. C. 1957. Diploid male tissue as new evidence on sex determination in honey bees (*Apis mellifera*). *J. Hered.*, **48**, 160-168.
- ROTHENBUHLER, W. C. 1958. Progress and problems in the analysis of gynandromorphic honey bees. In *Proceedings 10th International Congress of Entomology*, vol. 2, pp. 867-874.
- ROTHENBUHLER, W. C., GOWEN, J. W., AND PARK, O. W. 1952. Androgenesis with zygotenesis in gynandromorphic honey bees (*Apis mellifera* L.). *Science*, **115**, 637-638.
- RUSSELL, W. L., RUSSELL, L. B., AND GOWER, J. S. 1959. Exceptional inheritance of a sex-linked gene in the mouse explained on the basis that X/O sex-chromosome constitution is female. *Proc. Nat. Acad. Sc.*, **45**, 554-560.
- RUSSELL, W. T. 1936. Statistical study of the sex ratio at birth. *J. Hyg.*, **36**, 381-401.
- SANDBERG, A. A., CROSSWHITE, L. H. AND GORDY, E. 1960. Trisomy of a large chromosome. Association with mental retardation. *J. A. M. A.*, **174**, 221-225.
- SANDBERG, A. A., KOEFF, G. F., CROSSWHITE, L. H., AND HAUSCHKA, T. 1960. The chromosome constitution of human marrow in various developmental and blood disorders. *Am. J. Human Genet.*, **12**, 231-249.
- SANDERSON, A. R., AND HALL, D. W. 1948. The cytology of the honey bee, *Apis mellifica* L. *Nature*, London, **162**, 34-35.
- SANDERSON, A. R., AND HALL, D. W. 1951. Sex in the honey bee. *Endeavour*, **10**, 33-39.
- SASAKI, M., AND MAKINO, S. 1960. The chromosomal constitution of a human *hermaphrodite*. *Texas Rep. Biol. & Med.*, **18**, 493-500.
- SATINA, S., AND BLAKESLEE, A. F. 1925. Studies on biochemical differences between (+) and (-) sexes in murens. *Proc. Nat. Acad. Sc.*, **11**, 528-534.
- SATO, H. 1942. Cytological studies of the eggs of silkworm exposed to high temperature. I. *H. Sanshigaku-zasshi*, 14(1).
- SCHMIEDER, R. G., AND WHITING, P. W. 1947. Reproductive economy in the chalcidoid wasp *Melittobia*. *Genetics*, **32**, 29-37.
- SCHIRADER, F. 1928. *Die Geschlechtschromosomen (The sex chromosomes)*. Berlin: Gebrüder Borntraeger.
- SCHIRADER, F., AND STURTEVANT, A. H. 1923. A note on the theory of sex determination. *Am. Naturalist*, **57**, 379-381.
- SHEP, T. H. 1932. Zytologische Untersuchungen über sterilität bei Männchen von *Drosophila melanogaster* und bei F. Männchen der Kreuzung zwischen *D. simulans* Werbchen und *D. melanogaster* Männchen. *Ztschr. Zellforsch.*, **15**, 547-580.
- SHIWAGO, P. I., AND ANDRES, A. H. 1932. Die Geschlechtschromosomen in der spermato-genese des Menschen. *Ztschr. Zellforsch.*, **16**, 413-431.
- SMITH, B. W. 1955. Sex chromosomes and natural polyploidy in dioecious *Rumex*. *J. Hered.*, **46**, 226-232.
- SMITH, D. W., PATAU, K., THERMAN, E., AND INHORN, S. L. 1960. A new autosomal trisomy syndrome: multiple congenital anomalies caused by an extra chromosome. *J. Pediatr.*, **57**, 338-345.
- SMITH, S. G. 1955. Cytogenetics of obligatory parthenogenesis. *Canad. Entomol.*, **87**, 131-135.
- SMITH-WHITE, S. 1955. The life history and genetic system of *Leucopogon juniperinus*. *Heredity*, **9**, 79-91.
- SNEEP, J. 1953. The significance of andromonoecy for the breeding of *Asparagus officinalis* L. *Euphytica*, **2**, 89-95.
- SNEEL, G. D. 1935. The determination of sex in *Hedrobracon*. *Proc. Nat. Acad. Sc.*, **21**, 446-453.
- SONNEBORN, T. M. 1937. Sex, sex inheritance and sex determination in *Paramecium aurelia*. *Proc. Nat. Acad. Sc.*, **23**, 378-385.
- SONNEBORN, T. M. 1947. Recent advances in the genetics of *Paramecium* and *Euplates*. *Advances Genet.*, **1**, 264-358.
- SONNEBORN, T. M. 1949. Ciliated protozoa: Cytogenetics, genetics, and evolution. *Ann. Rev. Microbiol.*, **3**, 55-80.
- SONNEBORN, T. M. 1957. Breeding systems, reproductive methods, and species in protozoa. In *The Species Problem*, pp. 163-324. Washington: American Association for the Advancement of Science.
- SPECKLING, L. S. 1960. The chromosome complement of the developing eggs produced by *Drosophila parthenogenetica* Stalker virgin females. *Genetics*, **45**, 243-256.
- SPURWAY, H., AND HALDANE, J. B. S. 1951. Genetics and cytology of *Drosophila subobscura*. IX. An autosomal recessive mutant transforming homogametic zygotes into intersexes. *J. Genet.*, **52**, 208-225.
- STALKER, H. D. 1942. Triploid intersexuality in *D. americana* Spencer. *Genetics*, **27**, 504-518.
- STALKER, H. D. 1951. Parthenogenesis in *Drosophila*. *Genetics*, **39**, 4-34.
- STALKER, H. D. 1956a. On the evolution of parthenogenesis in *Lonchoptera* (Diptera). *Evolution*, **10**, 345-359.
- STALKER, H. D. 1956b. Selection within a unisexual strain of *Drosophila* (Abstr.). *Rec. Genet. Soc. Am.*, **25**, 662. *Genetics*, **41**, 662.
- STERN, C. 1929. Untersuchungen über Abertreibungen des Y Chromosoms von *Drosophila melanogaster*. *Ztschr. indukt. Abstammungs-Vererb.*, **51**, 253-353.
- STERN, C. 1936. Somatic crossing-over and segre-

- gation in *Drosophila melanogaster*. *Genetics*, **21**, 625-730.
- STERN, C. 1959a. Color-blindness in Klinefelter's syndrome. *Nature*, London, **183**, 1452-1453.
- STERN, C. 1959b. Use of the term "superfemale". *Lancet*, **2**, 1088 (7111).
- STERN, C., AND HADORN, E. 1938. The determination of sterility in *Drosophila* males without a complete Y chromosome. *Am. Naturalist*, **72**, 42-52.
- STERNBERG, W. H., AND KLOEPFFER, H. W. 1960. Genetic and pathologic study of "simulant" females (testicular feminization syndrome). *Am. Soc. Human Genet.*, 11-12 (Abstr.).
- STEWART, J. S. S. 1959. Testicular feminization and colour-blindness. *Lancet*, **2**, 592-594 (7103).
- STEWART, J. S. S. 1960a. Gonadal dysgenesis. The genetic significance of unusual variants. *Acta Endocrinol.*, **33**, 89.
- STEWART, J. S. S. 1960b. Genetic mechanisms in human intersexes. *Lancet*, **1**, 825-826 (7128).
- STEWART, J. S. S., AND SANDERSON, A. R. 1960. Fertility and oligophrenia in an apparent triplo-X-female. *Lancet*, **2**, 21-22 (7140).
- STONE, W. S. 1942. The  $Ix^B$  factor and sex determination. *Univ. Texas Publ.*, **4228**, 146-152.
- STURTEVANT, A. H. 1920a. Intersexes in *Drosophila simulans*. *Science*, **51**, 325-327.
- STURTEVANT, A. H. 1920b. Genetic studies on *Drosophila simulans*. I. Introduction. Hybrids with *Drosophila melanogaster*. *Genetics*, **5**, 488-500.
- STURTEVANT, A. H. 1921. Genetic studies on *Drosophila simulans*. III. Autosomal genes; general discussion. *Genetics*, **6**, 179-207.
- STURTEVANT, A. H. 1923. Inheritance of direction of coiling in *Limnaea*. *Science*, **58**, 269-270.
- STURTEVANT, A. H. 1945. A gene in *Drosophila melanogaster* that transforms females into males. *Genetics*, **30**, 297-299.
- STURTEVANT, A. H. 1946. Intersexes dependent on a maternal effect in hybrids between *Drosophila repleta* and *D. acorepleta*. *Proc. Nat. Acad. Sc.*, **32**, 81-87.
- STURTEVANT, A. H. 1949. The Beaded Minute combination and sex determination in *Drosophila*. *Proc. Nat. Acad. Sc.*, **35**, 311-313.
- STURTEVANT, A. H. 1956. A highly specific complementary lethal system in *Drosophila melanogaster*. *Genetics*, **41**, 118-123.
- STURTEVANT, A. H., AND DOBZHANSKY, T. 1936. Geographical distribution and cytology of "sex ratio" in *Drosophila pseudoobscura* and related species. *Genetics*, **21**, 473-490.
- STOMALAINEN, E. 1950. Parthenogenesis in animals. *Advance Genet.*, **3**, 193-253.
- STOMALAINEN, E. 1951. The cytology of the parthenogenetic ctenidionids of Switzerland. *Chromosoma*, **6**, 627-655.
- SYVERTON, J. T. 1957. Comparative studies of normal and malignant human cells in continuous culture. In *Cellular Biology, Nucleic Acids and Viruses*. New York Acad. Sc., special publ., **5**, 331-340.
- TABER, S., 3RD. 1955. Evidence of binucleate eggs in the honey bee. *J. Hered.*, **46**, 156.
- TANAKA, Y. 1952. *Genetics of the Bombyx mori*. Tokyo: Shokado Company.
- TANAKA, Y. 1953. Genetics of the silkworm, *Bombyx mori*. *Advance Genet.*, **5**, 239-317.
- TAYLOR, J. H. 1957. The time and mode of duplication of chromosomes. *Am. Naturalist*, **91**, 209-221.
- TAZIMA, Y. 1941. Larval striations as a simple means for the differentiation of sex. *J. sci. cult. Sec. Japan.*, 12(3).
- TAZIMA, Y. 1952. Sex determination. In *Genetics of the Bombyx mori*, Y. Tanaka, Ed., pp. 351-372. Tokyo: Shokado Company.
- THOMPSON, D. H. 1920. A new type of sex-linked lethal mutant in *Drosophila*. *Anat. Rec.*, **20**, 215.
- TJIO, J. H., AND LEVAN, A. 1956. The chromosome number of man. *Hereditas*, **42**, 1-6.
- TJIO, J. H., AND PUCK, T. T. 1955a. Genetics of somatic mammalian cells. II. Chromosomal constitution of cells in tissue culture. *J. Exper. Med.*, **103**, 259-268.
- TJIO, J. H., AND PUCK, T. T. 1955b. The somatic chromosomes of man. *Proc. Nat. Acad. Sc.*, **44**, 1229-1237.
- TJIO, J. H., PUCK, T. T., AND ROBINSON, A. 1959. The somatic chromosomal constitution of some human subjects with genetic defects. *Proc. Nat. Acad. Sc.*, **45**, 1008-1016.
- TOKUNAGA, C. 1958. The Y chromosome in sex determination of *Aphiochaeta xanthina*. In *Proceedings 10th International Congress of Genetics, Montreal*, Vol. 2, pp. 295-296 (Abstr.).
- TUCKER, K. W. 1958. Automictic parthenogenesis in the honey bee. *Genetics*, **43**, 299-316.
- TURPIN, R., LEFEUNE, J., LAFOURCADE, J., AND GAUTIER, M. 1959. Aberrations chromosomiques et maladies humaines. La polydyspondylie a 45 chromosomes. *Compt. rend. Acad. Sc.*, **248**, 3636-3638.
- WARMKE, H. E. 1946. Sex determination and sex balance in *Melandrium*. *Am. J. Botan.*, **33**, 648-660.
- WARMKE, H. E., AND BLAKESLEE, A. F. 1939. Sex mechanisms in polyploids of *Melandrium*. *Science*, **89**, 391-392.
- WARMKE, H. E., DAVIDSON, H., AND LECLERC, G. 1945. Polyploidy investigations. In *Annual Report, Director of Department of Genetics, Carnegie Institute Year Book*, vol. 44, pp. 113-115.
- WEIR, J. A. 1958. Sex ratio related to sperm source in mice. *J. Hered.*, **49**, 223-227.
- WELSHONS, W. J., AND RUSSELL, L. B. 1959. The Y chromosome as the bearer of male determining factors in the mouse. *Proc. Nat. Acad. Sc.*, **45**, 560-566.
- WESTERGAARD, M. 1940. Studies on cytology and sex determination in polyploid forms of *Melandrium album*. *Dansk Botan. Ark.*, **10**, 1-31.
- WESTERGAARD, M. 1946a. Structural changes of

- the Y chromosome in the offspring of polyploid *Melandrium*. *Hereditas*, **32**, 60-61.
- WESTERGAARD, M. 1946b. Aberrant Y chromosomes and sex expression in *Melandrium album*. *Hereditas*, **32**, 419-443.
- WESTERGAARD, M. 1948. The relation between chromosome constitution and sex in the offspring of triploid *Melandrium*. *Hereditas*, **34**, 257-279.
- WESTERGAARD, M. 1953. Über den Mechanismus der Geschlechtsbestimmung bei *Melandrium album*. *Naturwissenschaften*, **40**, 253-260.
- WESTERGAARD, M. 1958. The mechanism of sex determination in dioecious flowering plants. *Advance Genet.*, **9**, 217-281.
- WHITE, M. J. D. 1954. *Animal Cytology and Evolution*, 2nd ed. Cambridge: Cambridge University Press.
- WHITING, P. W. 1933a. Selective fertilization and sex determination in Hymenoptera. *Science*, **78**, 537-538.
- WHITING, P. W. 1933b. Sex determination in Hymenoptera. *Biol. Bull.*, **65**, 357-358.
- WHITING, P. W. 1935. Sex determination in bees and wasps. *J. Hered.*, **26**, 263-278.
- WHITING, P. W. 1943a. Multiple alleles in complementary sex determination of *Habrobracon*. *Genetics*, **28**, 365-382.
- WHITING, P. W. 1943b. Androgenesis in the parasitic wasp *Habrobracon*. *J. Hered.*, **34**, 355-366.
- WHITING, P. W. 1958. Diploid males and triploid females in *Habrobracon* and *Mormoniella*. *Bull. A. Southeastern Biol.*, **5**, 16.
- WHITING, P. W., AND WHITING, A. R. 1925. Diploid males from fertilized eggs in *Habrobracon*. *Science*, **63**, 437-438.
- WIESE, L. 1960. Die diplogenetypische Geschlechtsbestimmung. *Fortschr. Zool.*, **12**, 295-335.
- WILSON, E. B. 1928. *The Cell in Development and Heredity*, 3rd ed. New York: The Macmillan Company.
- WINGE, O. 1922. A peculiar mode of inheritance and its cytological explanation. *Compt. rend. trav. lab. Carlsberg*, **17**, 1-9.
- WINGE, O. 1934. The experimental alteration of sex chromosomes into autosomes and vice versa, as illustrated by *Lebistes*. *Compt. rend. trav. lab. Carlsberg, sér. physiol.*, **21**, 1-49.
- WINGE, O., AND DITLEVSEN, E. 1948. Colour inheritance and sex determination in *Lebistes*. *Compt. rend. trav. lab. Carlsberg, sér. physiol.*, **24**, 227-248.
- WITSCHI, E., NELSON, W. O., AND SEGAL, S. J. 1957. Genetic developmental and hormonal aspects of gonadal dysgenesis and sex inversion in man. *J. Clin. Endocrinol.*, **17**, 737-753.
- WOLF, E. B. 1960. Eine Nachuntersuchung zur Cytologie der Honigbiene (*Apis mellifica* L.). *Zool. Beitr., neue folge*, **5**, 373-391.
- YAMAMOTO, T.-O. 1953. Artificially induced sex-reversal in genotypic males of the medaka (*Oryzias latipes*). *J. Exper. Zool.*, **123**, 571-594.
- YAMAMOTO, T.-O. 1957. Esterone-induced intersex of genetic male in the medaka, *Oryzias latipes*. *J. Fac. Sc. Hokkaido Univ., ser. VI, Zool.*, **13**, 440-444.
- YAMAMOTO, T.-O. 1959a. A further study on induction of functional sex-reversal in genotypic males of the medaka (*Oryzias latipes*) and progenies of sex-reversals. *Genetics*, **44**, 739-757.
- YAMAMOTO, T.-O. 1959b. The effect of estrone dosage level upon the percentage of sex-reversals in genetic male (XY) of the medaka (*Oryzias latipes*). *J. Exper. Zool.*, **141**, 133-153.
- YAMAMOTO, Y. 1938. Karyogenetische Untersuchungen bei der Gattung *Rumex*. VI. Geschlechtsbestimmung bei eu- und aneuploiden Pflanzen von *Rumex acetosa* L. *Mem. Coll. Agric. Kyoto Imp. Univ.*, **43**, 1-59.
- YAO, T., AND OLSEN, M. W. 1955. Microscopic observations of parthenogenetic embryonic tissues from virgin turkeys. *J. Hered.*, **46**, 132-134.
- YOKOYAMA, T. 1959. *Silkworm Genetics Illustrated*. Tokyo: Japan Society for Promotion of Science.
- ZOSCHKE, U. 1956. Untersuchungen über die Bestimmung des Geschlechtes beim Spinat unter besonderer Berücksichtigung der Züchtung eines monözischen oder gleichzeitig schossenden Spinats. *Zuschr. Pflanzenzücht.*, **35**, 257-296.

# 2

## ROLE OF HORMONES IN THE DIFFERENTIATION OF SEX

R. K. Burns, Ph.D., D.Sc. (hon.)

CARNEGIE INSTITUTION OF WASHINGTON, DEPARTMENT OF EMBRYOLOGY,  
THE JOHNS HOPKINS UNIVERSITY, BALTIMORE, MARYLAND

I. THE HORMONE THEORY OF SEX DIFFERENTIATION . . . . .	76	A. Differentiation of the Embryonic Gonads . . . . .	111
II. METHODS OF EXPERIMENTAL ANALYSIS . . . . .	78	1. The Müllerian ducts . . . . .	112
A. Grafting of Gonads or Gonad Tissues in Bird Embryos . . . . .	78	2. The male duct system . . . . .	120
B. Grafting Experiments in Amphibian Embryos . . . . .	79	B. Derivatives of the Cloaca and Urinogenital Sinus . . . . .	121
C. Use of Pure Hormones as Sex Differentiating Agents . . . . .	82	C. External Genital Structures . . . . .	127
D. Sex Differentiation in the Absence of Hormones . . . . .	82	D. Differentiation of Other Types of Sex Character . . . . .	129
III. THE BISEXUAL ORGANIZATION OF THE EARLY EMBRYO AS THE BASIS OF SEX REVERSAL . . . . .	83	VI. THE PITUITARY AND THE DIFFERENTIATION OF SEX . . . . .	132
IV. EXPERIMENTAL REVERSAL OF SEX DIFFERENTIATION IN THE GONADS . . . . .	83	VII. GROUP DIFFERENCES IN THE RELATIONS OF HORMONES TO SEX . . . . .	134
A. Bisexual Organization of the Gonad and the Physiologic Mechanism of Sex Differentiation . . . . .	83	VIII. THE ORGANIZATION OF THE SEX PRIMORDIUM AND ITS ROLE IN THE DIFFERENTIATION OF SEX . . . . .	137
B. Sex Reversal in Amphibian Gonads . . . . .	86	A. Constitution and the Morphologic Representation of Sex Primordia . . . . .	137
1. Constitutional differences and the character of the reversal process . . . . .	86	B. Constitutional Factors and Physiologic Differences in the Organization of Sex Primordia . . . . .	138
2. Parabiosis and grafting of the gonad or the gonad primordium . . . . .	87	C. Influence of Sex Genotype on the Reactions of Sex Primordia . . . . .	139
3. Administration of steroid hormones . . . . .	91	IX. THE TIME FACTOR IN THE RESPONSES OF SEX PRIMORDIA: RECEPTIVITY AND "CRITICAL PERIODS" . . . . .	140
C. SEX REVERSAL IN AVIAN GONADS . . . . .	95	X. SPECIFICITY OF HORMONE ACTION AND THE SIGNIFICANCE OF PARADOXICAL EFFECTS . . . . .	141
1. Organization of avian gonads . . . . .	95	XI. TIME OF ORIGIN AND THE SOURCE OF GONAD HORMONES . . . . .	143
2. Effects of administering pure hormones . . . . .	96	XII. A COMPARISON OF THE EFFECTS OF EMBRYONIC AND ADULT HORMONES IN SEX DIFFERENTIATION . . . . .	145
3. Effects of grafting gonads into the coelomic cavity . . . . .	99	XIII. EMBRYONIC HORMONES AND INDUCTOR SUBSTANCES . . . . .	148
4. Sex reversal <i>in vitro</i> . . . . .	100	XIV. REFERENCES . . . . .	151
D. The Problem of Sex Reversal in Mammalian Gonads . . . . .	100		
1. Bisexual potentialities in the embryonic gonads of mammals . . . . .	100		
2. Bisexual potentiality in the embryonic ovary of the rat . . . . .	103		
3. Experimental transformation of the testis in the opossum . . . . .	105		
V. THE ROLE OF HORMONES IN THE DEVELOPMENT OF THE ACCESSORY SEX STRUCTURES . . . . .	110		

### I. The Hormone Theory of Sex Differentiation

The modern era in the study of the physiology of sex differentiation is usually dated from the solution of the freemartin problem through the simultaneous but entirely inde-



pendent studies of Lillie (1916, 1917) and Keller and Tandler (1916). The theoretic explanation of the anomaly proposed by these authors was generally accepted and had two far-reaching effects; it at once provided a simple, functional concept of the nature of embryonic sex differentiation which was readily susceptible of experimental test, and it directly stimulated the pioneer experiments in the field—the attempt to control sex differentiation in chick embryos by grafting gonad tissue to the chorioallantoic membrane (Minoura, 1921) and the application of the technique of parabiosis to the problem in amphibian embryos (Burns, 1924, 1925). However, as is usually the case with epoch-making theories, the concept of hormonal control of embryonic sex differentiation had roots going far back into the past.

The effects of castration in domestic animals and in humans had been familiar since earliest times, and it was long appreciated that in the vertebrates the gonads are necessary for maintaining the structural integrity of the accessory organs of reproduction and for the regulation of their functional activities. It was first clearly demonstrated by Berthold (1849) that this control is exercised through the agency of a substance (of a nature as yet unknown) produced in the gonads and carried throughout the body in the circulating blood (for the historical background of this experiment see Forbes, 1949). Thus the conception of a blood-borne agent capable of controlling the growth and activities of distant structures, was established long before the name *hormone* was given to such substances. The theory that the *differentiation of the genital structures in the embryo* is controlled by a hormone, or hormones, produced by the embryonic gonads was a natural outgrowth of this knowledge. This view was first proposed as an hypothesis by Boutin and Aneel in 1903, suggested by the observation of an unusually rich interstitium in the testes of pig embryos during the period of sex differentiation. No direct evidence in support of the hypothesis was forthcoming, however, until the hormone theory, in virtually its present outlines, was formulated by Lillie and by Keller and Tandler as an explanation of the freemartin.

The freemartin<sup>1</sup> had been familiar to breeders of cattle for centuries as a sexually abnormal calf, born as twin to a normal male, and its anatomy had been accurately described by John Hunter in the eighteenth century (for references see Lillie, 1917). The external genitalia and mammary glands are typically female in character and the animal was usually regarded as a female, but in rare cases the clitoris may be greatly enlarged and peniform (Numan, 1843, see Lillie, 1917, Fig. 29; Buysse, 1936). Internally, however, elements of the genital tracts of both sexes are present and frequently well developed, and later investigators were often in disagreement as to the primary sex of the creature. The gonads of the freemartin are rudimentary in form but usually show the histologic structure of an abnormal testis which is almost invariably sterile (for an exception see Hay, 1950, and also Hart, cited by Lillie, 1917, page 417). In many cases, however, the gonads are intersexual, showing varying degrees of agenesis of the ovarian cortex associated with rudimentary tubular structures in the medullary or hilar regions (Chapin, 1917; Willier, 1921). Commonly a well developed male duct system is present, but the development of the female genital tract is variable and in the more modified cases it may be virtually absent.

It is unnecessary to go into the various lines of evidence which were used to establish the fact that the freemartin is zygotically a female (Lillie, 1917, 1923); the point has recently been demonstrated cytologically by the Barr method (Moore, Graham and Barr, 1957). It will be useful, however, to review the circumstances which pointed to the cause of the anomaly. A freemartin is always associated at birth with a male twin (which is normal) and never with another female; in addition, the dizygotic origin of the pair was demonstrated by Lillie in many cases. Furthermore, for the birth of a freemartin it is necessary that the placentas of the twins be united, with the presence of vascular anastomoses (Fig. 2.1). In the absence of such connections the female twin is always normal. There is a correlation between the degree of abnormality

<sup>1</sup> For a discussion of the origin of this name see Forbes (1946).

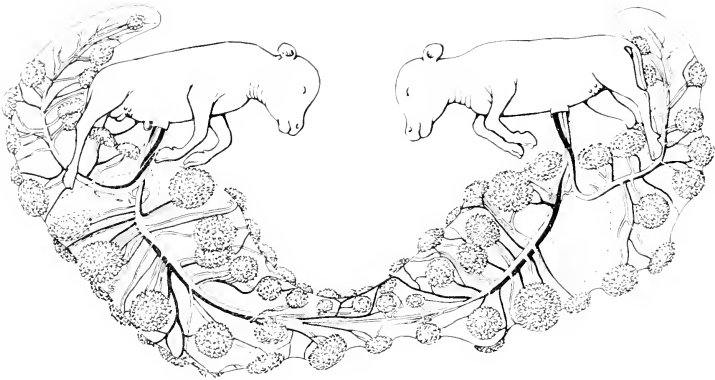

FIG. 21. Twin calves removed from the uterus, showing chorionic fusion and anastomosis between major vessels; male twin, left; freemartin, right. (After F. R. Lillie, *J. Exper. Zool.*, **23**, 371-452, 1917).

observed and the extent of the vascular union, and also with the stage of development at which the anastomosis was presumably established. The constancy with which these conditions appear pointed inevitably to the conclusion that the abnormal development of the female twin is caused by the transfusion, from an early stage of development, of a hormone produced by the gonads of the male twin. The invariable dominance of the male member of the pair was explained provisionally on the basis of histologic studies (Lillie and Bascom, 1922; Bascom, 1923) which indicated that the testis is active endocrinologically long before the ovary (*cf.* Bouin and Ancel, 1903). This conclusion has been supported in recent years by the results of castration in mammalian embryos (*q.v.*).<sup>2</sup>

<sup>2</sup> Recently evidence has come from quite different sources that in most twins or multiple births in cattle, placental anastomoses are established at an early stage. Calves, even when of different sex and with other characteristics indicating dizygotic or polyzygotic origin, possess identical complements of blood factors (red cell agglutination types), which can only be explained on the basis of an early exchange of blood (Owen, Davis and Morgan, 1946). Since erythrocytes are comparatively short-lived cells, it is indicated in these cases that primitive erythroblasts must have been exchanged early in development and colonized the hemopoietic tissues of the recipients. It has been shown also (Anderson, Billingham, Lamson and Medawar, 1951) that dizygotic twin calves of dif-

## II. Methods of Experimental Analysis

The demonstration in the case of the freemartin of the probable nature of the transforming agent and its mode of transmission at once suggested means of attacking the problem of embryonic sex differentiation experimentally. At first grafting methods were mainly employed, using the embryos of birds and amphibians.

### A. GRAFTING OF GONADS OR GONAD TISSUES IN BIRD EMBRYOS

Historically, the first experiments were those of Minoura (1921) who transplanted pieces of adult testis or ovary to the chorio-allantois of chick embryos during the period of sex differentiation. Such grafts become vascularized and are then in communication with the host embryo by way of the umbilical circulation. Various modifications of

different sex are, with few exceptions, tolerant to grafts of each other's skin. This is true of skin exchanges in monozygotic twins (as would be expected) but is never found in other degrees of relationship. As in the preceding case, the explanation is found in an early transfusion of blood between the twins. The exceptional cases are doubtless to be explained (as in the freemartin study) on the occasional failure of placental anastomosis to occur. This evidence is cited for its bearing on the point of early exchange of blood; the fact that blood cells and other elements are exchanged does not seem to be of significance for the sex hormone theory.

the embryonic genital structures of the host (especially of the Müllerian ducts) were noted and attributed to the influence of the grafted tissues. But later investigators failed to confirm these findings, and it was shown eventually that the anomalies observed by Minoura were unspecific in character and bore no constant relation to the sex of the grafted tissue (for a review and discussion see Willier, 1939). Similar modifications were also found after transplantation of various nongonadal tissues, and are apparently induced by changes in the physical environment incidental to operation, such as lowering of the temperature and the humidity (Willier and Yuh, 1928). Evidently the original experiments had not been adequately controlled with respect to such factors.

Obviously this type of experiment does not correspond exactly with conditions in the freemartin. The grafted tissue came from adult gonads, and there was no way of determining the hormone output of such grafts or whether, indeed, they produced hormones at all. Furthermore, sexual differentiation in the host embryos has generally begun before transplantation to the chorioallantois is practicable. This objection was avoided, however, by modifying the experiment. *Sexually undifferentiated embryonic gonads* were transplanted to the chorioallantoic membrane of a host embryo already well advanced in sex differentiation. In this case changes might be anticipated in the grafts. However, this experiment, as well as transplantation of the gonad-forming region of the blastoderm (Willier, 1927, 1933), also gave negative results. The grafted gonads differentiated to a variable degree, depending on the state of development of the primordia at the time of transplantation, but when sexual differentiation occurred it showed no constant relation to the sex of the host.

These failures to obtain evidence that gonad tissues growing on the chorioallantois influence the differentiation of host structures, or are themselves modified by the hormones of the host, raised serious doubt as to the role of hormones in embryonic sex differentiation in birds; and this feeling was not entirely removed by the demonstration

some years later that the sexual differentiation of the chick can be readily modified by treatment with pure hormone preparations. It was not until embryonic gonads were transplanted directly into the *body cavity* of another embryo (Bradley, 1941; Wolff, 1946) that unmistakable evidence was obtained. The conditions under which this result was achieved—close proximity of the graft to the developing host structures—suggested that the failure to obtain positive results by chorioallantoic grafting was perhaps largely a matter of the quantity or concentration of the hormone. Recently, however, a true "freemartin effect" has been reported in twin chicks of different sex, which developed from an egg with two yolks (Lutz and Lutz-Ostertag, 1958). There was local development of cortex on the left testis of the male twin, and a marked inhibition of the Müllerian ducts of the female, effects paralleling those produced by intra-coelomic gonad grafts. This is the only recorded case of a natural freemartin in birds.

#### B. GRAFTING EXPERIMENTS IN AMPHIBIAN EMBRYOS

The principal experimental procedures developed for amphibian embryos are illustrated diagrammatically in Figure 2.2, which shows the different modes of grafting, and the resulting vascular relationships, as compared with the freemartin (Fig. 2.1). The first experiments actually undertook to reproduce as nearly as possible the situation which arises by chance in the freemartin. The method devised was *parabiosis*—the grafting together of two embryos in the manner of "Siamese twins" (Burns, 1925) so that in later development there is a common circulation (Figs. 2.2A and 2.9). When members of such a pair happen to be genetically of the same sex, normal sexual differentiation would be expected to follow; but in pairs of different sex opportunity for cross-circulation of sex hormones is provided. Circulatory anastomosis is established in such pairs long before the beginning of sex differentiation in the gonads, and so a favorable situation is provided for testing the possibility of hormone action. The results obtained by this method vary

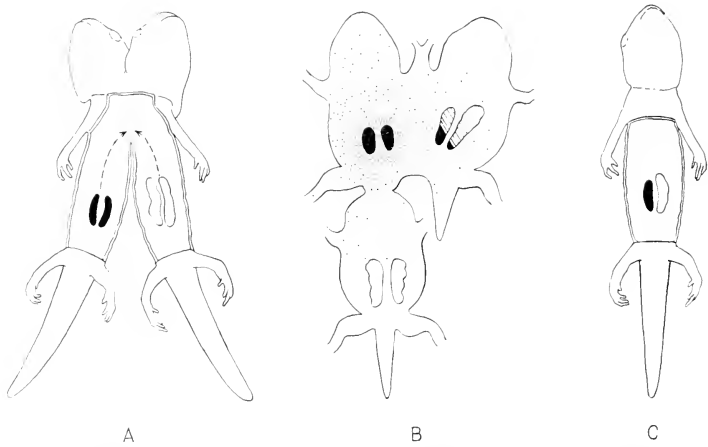

FIG. 2.2. Diagram illustrating different modes of grafting in amphibians in order to bring about vascular continuity between individuals, and association of gonads of different sex. A. Homoplastic twins in salamanders. The body cavities are largely separated and vascular communications between the gonads are remote. For combination of dissimilar species see Fig. 2.9B. B. Anuran twins, showing side-to-side or head-to-tail union; reversal changes appear only under the first condition, when the gonads are in close proximity. (After E. Witschi, in *Sex and Internal Secretions*, The Williams & Wilkins Company, 1932). C. Orthotopic transplantation of the gonad primordium by the method illustrated in Fig. 2.4, resulting in two gonads of opposite sex resident in a single individual (Humphrey's method).

greatly, depending on the species under study and on various experimental conditions, as will appear later.

The grafting of gonads alone (as opposed to the union of whole organisms) can be carried out in embryonic stages of development or in early larval life. The latter method was tried first. The gonads, attached to a segment of the mesonephric bodies, were removed from young larvae at or soon after the onset of sex differentiation and inserted into the body cavity of older larvae (Burns, 1928). The development and activity of such grafts depends on the extent to which they become attached and vascularized. When graft and host are of different sex the grafts typically become intersexual, developing the structure of ovotestes; and when a large and well differentiated graft is in close proximity to the gonads of the host the latter may be similarly modified (Fig. 2.3). This method of grafting has the disadvantage, however, that reversal is usually incomplete, and when graft and host gonads show reciprocal modification it is sometimes difficult to determine the primary sex of either.

The method described above was soon greatly improved upon by the development of a technique for transplanting, at an earlier stage, the prospective gonad-forming tissue from one embryo to another (Humphrey 1928a, b). At first such grafts were placed in ectopic locations, but later it was found advantageous to place them in the normal (orthotopic) position in an embryo from which the corresponding gonad primordium had been excised (Fig. 2.4). After such an operation the host embryo bears on one side its own gonad and on the other a gonad which, in approximately half of all cases, has come from an embryo of the other sex (Fig. 2.2C). This method has important advantages over those previously described. A single embryo bearing an orthotopic graft survives better and is more easily reared than are parabiotic pairs, and gonads grafted in the orthotopic position usually develop better than in foreign surroundings. Most important of all, the donor embryo may be reared, thus establishing with certainty the original sex of the grafted gonad. This precise method has yielded un-

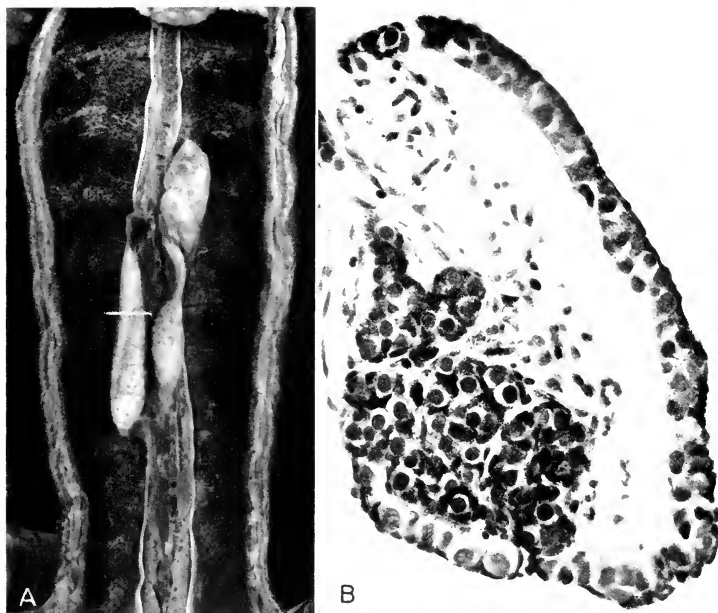

FIG. 23. Transplantation of the salamander gonad in early larval life (Burns, 1928): previously unpublished photographs. *A*. A large, but somewhat degenerate, grafted ovary lies just anterior to (above) the gonads of the host, which show changes in external form in the vicinity of the graft. *B*. Cross-section of host's right testis at the level of the white line, showing normal medullary development with well differentiated testis lobules, and peripherally a strongly developed cortex.

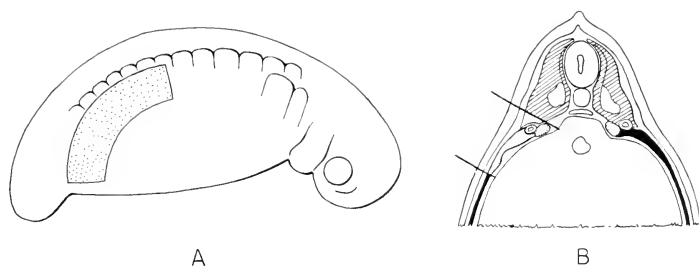

FIG. 24. Diagrams illustrating Humphrey's orthotopic transplantation method. *A*. Position of the gonad- and mesonephros-forming area of the embryo (stippled) which is excised and reimplanted in the corresponding position in a host embryo from which the primordium has just been removed. *B*. Cross-section of host at later stage showing position of the implanted material (between heavy lines) at the left. In the mesodermal layer a part of the lateral mesoderm lies below, the gonad- and mesonephros-forming material above, with the Wolffian duct at the top. Medial to the Wolffian duct lies the mass of primordial germ cells (more densely stippled).

equivocal results which have in general confirmed and extended those obtained by parabiosis.

#### C. USE OF PURE HORMONES AS SEX DIFFERENTIATING AGENTS

Early attempts to influence embryonic sex differentiation by the use of crude hormone preparations were almost entirely unsuccessful because of lack of potency, or the toxicity of the extracts. However, the isolation and eventual synthesis of steroid hormones made available a variety of active and nontoxic substances, and the use of pure hormones largely superseded grafting techniques. Direct administration of standard hormone preparations has the great advantage that dosages can be exactly known and regulated; also the timing of treatments is readily controlled and varied.

The first successful experiments using pure hormones were carried out on chick embryos. Similar results were obtained at almost the same time by several groups of investigators (Kozelka and Gallagher, 1934; Wolff and Ginglinger, 1935; Dantchakoff, 1935, 1936; Willier, Gallagher and Koch, 1935, 1937) who introduced the hormones, in oily or in aqueous solution, into the incubating egg. Striking transformations were produced, involving both the structure of the gonads and the accessory organs of sex. In the best cases reversal of the gonads was histologically almost complete.

The effects of crystalline sex hormones have also been investigated in many species of amphibians. Two methods have been utilized. Larvae may be treated individually by repeated injections, or in groups by continuous immersion, the hormone being dissolved in the water in which the larvae are reared. The latter method is particularly convenient for anuran tadpoles. Treatment can be started very early, the concentration is readily varied, and in many cases complete transformations have been obtained with the use of extremely low concentrations.

In mammalian embryos experimental study of sex differentiation was long delayed by the lack of operative techniques adequate for dealing with embryos *in utero*. The advent of pure hormones made possible the first successful experiments in this field.

In placental forms, in spite of a very high mortality, large doses of crystalline hormones can be administered to the mother during early stages of pregnancy with pronounced effects on the genital systems of the embryos (for a review of the earlier experiments see Greene, 1942, and for a recent summary Jost, 1955). About the same time, experiments were begun using the pouch young of a marsupial, the North American opossum (Burns, 1939a, b; Moore, 1941). So undeveloped are young marsupials at birth that virtually the entire course of morphologic sex differentiation takes place postnatally, and the embryos in the pouch are directly accessible for experimentation. Hormones were administered by injection (Burns) or by inunction, the application of an ointment containing the hormone to the skin. Except for minor differences attributable to dosage or other experimental factors, the results were similar, and in general agreement with those obtained in placental mammals by treatment during pregnancy.

#### D. SEX DIFFERENTIATION IN THE ABSENCE OF HORMONES

Although the evidence obtained by grafting techniques and by administration of hormones shows that the differentiation of embryonic genital structures may be profoundly modified or even completely reversed, such evidence is not in itself conclusive with respect to the central problem, the role of hormones in the normal differentiation of sex. The transmissible substances responsible for sex reversal in grafting experiments have not been isolated or identified and it may be argued that experiments with pure hormones show merely that the differentiating embryonic sex primordia are capable of reacting when hormones are introduced experimentally. Such evidence does not prove, however, that embryonic gonads actually produce such hormones. For this question the crucial test is the capacity of the embryonic genital structure to develop in the absence of gonads or removed from all hormonal influence.

Evidence on this point has been forthcoming in recent years and gives strong support to the hormone theory. Two different experimental approaches have been developed. Early castration of the embryo has

now been achieved in both mammals and birds, and improved methods of culturing embryonic organs *in vitro* have made it possible to observe for a sufficient time the development of sex primordia in complete physiologic isolation.

Since 1947 castration has been successfully performed in amniote embryos by two techniques, surgical castration and irradiation of the gonad region (for summaries see Jost, 1950; Wells, 1950; Raynaud, 1950; Wolff, 1950; Huijbers, 1951). In all cases serious failures of sexual differentiation follow removal or destruction of the gonads. Finally, the cultivation *in vitro* of individual sex primordia in virtual absence of hormonal influences has yielded results similar in all respects to those of castration. The results of these experiments will be taken up in detail as they relate to the development of particular structures.

### III. The Bisexual Organization of the Early Embryo as the Basis of Sex Reversal

The capacity of vertebrate embryos to undergo a reversal of sex, either spontaneously, as in various developmental anomalies of undetermined etiology ("intersexuality," "hermaphroditism"), or as a result of experiment, is based on the fact that every individual, regardless of genic sex constitution, passes in early development through a sexually undifferentiated or "indifferent" phase. During this period virtually all of the embryonic structures necessary for the development of either sex are laid down morphologically and are present for a certain time as *discrete primordia*. The extent to which the primordia of the genetically recessive sex are developed and the length of time during which they are present vary in different groups and species. This fact is of great importance in the experimental transformation of sex. In species in which the structures of the recessive sex are imperfectly represented, or are present for only a brief period in early development, opportunity for sex reversal is correspondingly limited; but in other cases the rudimentary structures of the recessive sex (as for example Müllerian ducts in males or vestigial prostatic glands in females) persist indefinitely and may even survive in the

adults of some species. The existence of a considerable degree of embryonic bisexuality in most groups (see Fig. 2.22) provides a definite morphologic basis for experimental transformation of sex and for the sporadic occurrence of sex anomalies as well.

The derivation of the various embryonic primordia which give rise to the male and female genital systems, and their history in the normal differentiation of sex, have been extensively reviewed by Willier (1939) and will not be taken up again in detail. The main features of normal development will be outlined briefly when dealing with the experimental behavior of individual structures. It must be remembered, however, that the individual parts of the genital system have widely different embryonic origins, and are morphologically and physiologically very dissimilar, and at any particular stage of development may vary greatly in their relative maturity and so in their reactivity to hormones. Many of the basic structures (*e.g.*, the embryonic sex ducts, the urinogenital sinus) are taken over bodily from other systems and only secondarily acquire a sexual status. It cannot be expected, therefore, that all parts of the developing sex complex will be capable at all times of responding harmoniously to experimental conditions which are often of necessity rigid and artificial or improperly timed. The recognition of such differences aids in understanding the variability so frequently encountered in the reactions of sex structures to hormones, and the importance of such experimental factors as the timing of treatment and dosage.

### IV. Experimental Reversal of Sex Differentiation in the Gonads

#### A. BISEXUAL ORGANIZATION OF THE GONAD AND THE PHYSIOLOGIC MECHANISM OF SEX DIFFERENTIATION

The sexually undifferentiated gonads of most amphibians exhibit bisexual organization in a primitive and simple form. In early larval life the gonad, irrespective of its future sex, contains two histologically distinct components in which male and female potentialities are segregated. Internally, there is a hilar or centrally placed

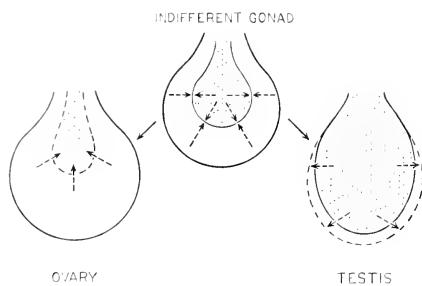

FIG. 2.5. Diagrammatic representation of the male and female components of the sexually undifferentiated amphibian gonad and their roles in sex differentiation: the medulla is stippled, the cortex is plain. The broken arrows indicate the mutually antagonistic or inhibitory actions exerted between the two components in the course of sexual differentiation (Witschi).

mass, the *medulla*, which has the developmental potentiality of a testis. Surrounding the medulla is a peripheral zone, the *cortex*, which is specifically female in potency. The topographic relationships of medulla and cortex are illustrated diagrammatically in Figure 2.5, and as they appear histologically in male salamanders in Figure 2.6A and B. Male and female potentialities are evidently pre-established in the medullary and corti-

cal components at an early stage since final differentiation as a testis or an ovary does not involve the transformation of one sex component into the other but rather the gradual predominance of one element and the recession of the other.

Not only are the two components distinctly segregated in the indifferent gonad, they have separate origins. It has long been recognized that the medulla in both sexes is derived from the mesonephric blastema in the form of a series of cellular strands, the *medullary cords* or *rete cords*, which grow into the genital ridge at an early stage. At first similar in appearance in the two sexes, their later differentiation follows very different patterns. In the ovary the cords expand distally, forming a series of saccular cavities, the *ovarian sacs*. Most of the germ cells are excluded from these sacs and come to lie in a peripheral layer beneath the peritoneal epithelium covering the gonad. This zone becomes the cortex. In prospective testes the cords branch and proliferate rapidly, enveloping and incorporating the majority of the germ cells in a compact central mass, the medulla (Fig. 2.6; for a fuller description see Willier, 1939). Thus the relative proportions of cortex and medulla in the sexes depend on the pattern of differen-

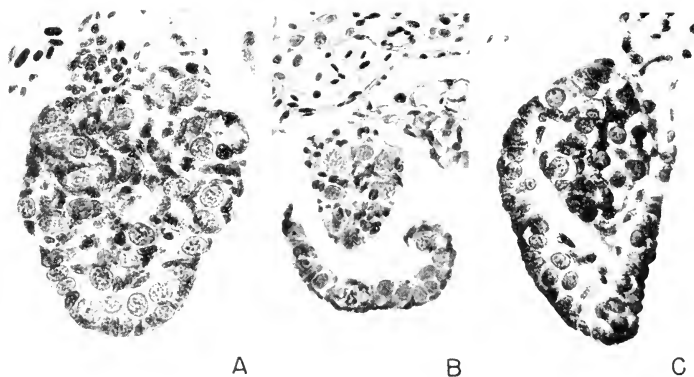

FIG. 2.6. Sections showing the histologic appearance of cortex and medulla in early larval stages under various conditions. A. Normal testis of an *Ambystoma tigrinum* larva; note the thin cortical zone, comparable to a germinal epithelium, which covers most of the surface. B. The cortex of an intersexual testis dissected free from the medullary core, from the punctatum member of an *Ambystoma tigrinum*, ♀; A. *Punctatum*, ♂ pair (cf. Burns, 1935, plate 4). C. Intersexual testis of the male member of a tigrinum-tigrinum pair, showing the relative development of the medullary and cortical components (see Burns, 1930).



tiation of the medullary cord, which results in a very unequal allocation of the germ cells between the two components. Probably the sex genotype acts primarily by determining the developmental pattern of the medullary cord. The role of the germ cells in the formation of the gonad appears to be a purely passive one since the non-germinal tissues are capable of producing the typical structure of a testis or an ovary in the absence of all germinal elements (for a review of this subject see Burns, 1955b).

The origin of the medullary component of the gonad from the mesonephric blastema and its dominant role in gonad formation has been demonstrated in a striking experiment by Houillon (1956). Formation of the gonad is dependent on the normal development of the mesonephros, and this can be repressed or entirely prevented by blocking the development of the primary nephric duct (pronephric duct) at an early stage. In the absence of the nephric duct the mesonephric blastema is reduced in quantity and delayed in its appearance; typically only a few mesonephric tubules develop and these are poorly differentiated. In consequence of the suppression of the mesonephric blastema, medullary cords are lacking or poorly developed, and the result is a vestigial gonad consisting chiefly of a rudimentary cortex. The essential role of the medullary cords in gonadogenesis is also demonstrated in the gonads of toads (Witschi, 1933) in which the so-called "organ of Bidder" corresponds to an anterior segment of the genital ridge in which medullary cords are absent.

The proportion of cortex to medulla as laid down in embryonic gonads depends primarily on genic constitution, but the stage of development is a factor in the representation of the two elements at any particular time, since during the progress of sexual differentiation one component (corresponding to the genetically determined sex) shows an increasing predominance from stage to stage. Furthermore, the morphologic representation of the two sex components in the indifferent gonad is subject to variation in different groups, species, or races. In some species the recessive component is weakly represented or virtually absent, even in early development, or when present its existence may be of brief dura-

tion. In such cases capacity for sex reversal is reduced or lacking. In other species, in which the recessive sex component is well developed, or when it persists over a considerable period of time, capacity for experimental reversal is correspondingly increased.

The alternative behavior of the cortical and medullary components of the gonad in normal differentiation, as well as their behavior under experimental conditions, long ago suggested that the physiologic mechanism of sex differentiation consists essentially of an antagonistic interaction between the two elements, in which the genetically dominant component gradually inhibits its antagonist (Fig. 2.5). This concept of "corticomedullary antagonism" (Witschi, 1932) has been generally accepted as the basic mechanism in the histologic differentiation of the gonad and forms the starting point for the inductor theory of sex differentiation.<sup>3</sup> A number of seemingly unrelated experimental procedures which are capable of inducing sex reversal all appear to have a common base of action by influencing or controlling this simple mechanism. For example, sex reversal is in some cases readily induced by external or environmental influences of an unspecific character, which apparently produce their effects by depressing or destroying the dominant gonad component.

Classical experiments of this type are the

<sup>3</sup> As originally formulated, this theory postulated simply that each gonad component produces a substance which specifically inhibits the differentiation of the other. These substances, called *medullarin* and *corticin*, were considered to be similar in character and to behave like the embryonic inductors of earlier development, being transmitted by diffusion and having strictly localized effects. Subsequently the theory was elaborated to allow for stimulatory as well as inhibitory action, with each inductor system assigned a dual role; accordingly, positive and negative factors were assumed and so designated, e.g., *medullarin*<sup>+</sup> and *medullarin*<sup>-</sup>. More recently it has been proposed that interactions between the sex inductors are of the nature of an immunologic reaction (Chang and Witschi, 1956), the positive factor appearing first in the role of an antigen which stimulates the other system to produce an antibody, the inhibitory factor (for the development of the inductor theory see Witschi, 1934, 1939, 1942, 1950, 1957). To account for the great taxonomic variability in the action of the sex inductors they are assumed to be proteins.

use of extremes of temperature to induce reversal of differentiation in the gonads of anuran larvae (Witschi, 1929; Piquet, 1930; Uchida, 1937). The reversal is due primarily to an unfavorable effect on the dominant component, high temperatures causing cortical degeneration in females and low temperatures inhibiting medullary development in males. Also, simple surgical interventions or even pathologic injury may have the same effect. Castration in certain cases results in complete reversal of sex through the reactivation and renewed development of a recessive gonad component left behind at operation. In adult male toads removal of the testes permits the organs of Bidder to develop into ovaries, which may become fully functional (Ponse, 1924). A comparable case is found in the reversal of sex which takes place in female chicks castrated soon after hatching. Removal of the dominant left ovary is followed by development of the rudimentary right gonad, composed largely or entirely of medullary tissue, into a small testis. Finally, rare cases of partial or complete sex reversal in adult hens, which occur as a result of pathologic destruction of the functional ovary, appear to have the same morphologic basis (Crew, 1923; for a discussion see Domm, 1939).

But although sex differentiation in most vertebrates ends in the complete dominance of one sex component, remarkable deviations from this plan are known in certain groups and species. An extreme is found in the prevalence of hermaphroditism, in varying degree, in many teleost fishes and in cyclostomes (see ch. 17) which may be of the juvenile type and temporary, or may persist in adults. In toads the curious structure known as *Bidder's organ* is present in adults of both sexes; it represents a local region of the genital ridge in which medullary cords are never formed and further differentiation does not occur. Since it corresponds morphologically to the cortical component of the gonad it retains throughout life the potentiality of an ovary. This condition is apparently possible in toads because of the very low level of antagonism in this genus. Stranger still is the situation found in the female of certain insectivores (the mole, Godet, 1949, 1950; the desman,

Peyre, 1952, 1955) in which the medulla of the adult ovary is testis-like and developed to a remarkable degree. Except during the reproductive period it greatly exceeds the cortex in bulk. Its cords are tubular in form, resembling testis tubules, and a well developed interstitium indicates an endocrine activity which is reflected in the strong masculinization of the genital tract. The clitoris is large and penis-like, and male accessory glands, absent or rudimentary in the females of most mammals, are well developed. Another species in which the ovarian medulla is highly developed, at least throughout fetal life, is the horse (Cole, Hart, Lyons and Catchpole, 1933). Thus many patterns are found with respect to the persistence of the heterotypic sex component of the ovary and its final fate.

#### B. SEX REVERSAL IN AMPHIBIAN GONADS

##### 1. *Constitutional Differences and the Character of the Reversal Process*

Modern amphibians, far from being a homogeneous group, are extremely diversified in structure and function and are often highly specialized. Such diversification obviously has had a long evolutionary history. Correspondingly, the processes of sex reversal as evoked experimentally in amphibian gonads, often follow very different histologic and physiologic patterns in different groups, species, or races. These differences must rest ultimately on genetic constitution; more immediately they are predetermined, in labile fashion at least, in the structural and physiologic organization of the gonad primordium which is in itself a complex system.

The organization of the early gonad may vary greatly (according to species and according to sex) with respect to the cortical and medullary elements as laid down histologically in the primordium—is the heterotypic sex component of the primordium well represented or is it quantitatively deficient from the beginning? The subsequent behavior of the heterotypic component is also important—does it persist and regress slowly over a considerable period of time or is its existence transient? Furthermore, how does it react when the normal balance of the dif-

ferentiation process is experimentally disturbed—does it respond readily by growth and differentiation or is it relatively inert and refractory? In particular cases the capacity of a gonad for reversal under experimental conditions obviously depends on which of the various situations prevails. Another variable concerns the humoral activity of the gonad, as regards the time of onset and the factors of quantity or rate of production. Species differ widely in this respect and marked sex differences are also found. Presumably all such characteristics exist as predispositions within the gonad primordium, but they are not as a rule irreversibly determined.

In addition the process of reversal, as seen histologically, may be influenced by experimental conditions such as the procedure employed, the stage of development at which reversal is initiated and the duration of the experiment. If conditions are favorable at the beginning of sex differentiation, reversal may take place directly without leaving obvious histologic traces, *i.e.*, an individual of one sex may adopt the developmental pattern of the other virtually from the start. If, on the other hand, transformation is not initiated until sex differentiation is well advanced, various stages of intersexuality will appear in the transforming gonads, until one sex component finally establishes complete dominance and the other disappears. The first situation commonly occurs when larvae are reared in optimal concentrations of hormone dissolved in the aquarium water; exposure to the hormone is continuous from a stage long antedating the appearance of morphologic sex differentiation, and all embryos regardless of sex genotype develop as one sex. However, the same result may occur also in grafting experiments (parabiosis or gonad transplantation) in which heteroplastic combinations of different species assure decisive predominance of one sex from the beginning by virtue of great inequality in size and in rate of development. The second situation is encountered when the conditions of the experiment do not lead to establishment of dominance at an early stage. Reversal sets in late, intersexual stages may be prolonged, and complete transformation may never occur.

## 2. *Parabiosis and Grafting of the Gonad of the Gonad Primordium*

Experiments of this kind involve the interaction of embryonic or larval gonads through the agency of substances of a humoral nature but of unknown chemical constitution. In some species, or under certain experimental conditions, the effects may be limited and highly localized, appearing only when the interacting gonads are in contact or in close proximity. Transport of the humoral agent takes place apparently by diffusion through the intervening tissues (Figs. 2.2*B* and 2.3). In other cases the effects are exerted over great distances and the substances must of necessity be carried in the blood. This does not necessarily mean, however, that different substances are involved in the two cases. As will be shown, hormones in low concentrations may have only local effects and, given a sufficient concentration in the blood stream, there is no reason to suppose that the so-called "inductor substances" could not act at a distance. The mode of transport does not seem to be crucial for the definition of these substances (for discussions see Willier, 1939, page 134, and Burns 1949, 1955b).

In most species of amphibians which have been investigated the male is the dominant sex. In grafting experiments, whether the method is parabiosis or transplantation of embryonic gonads, testes as a rule induce sex reversal in ovaries without being greatly modified themselves. In some cases dominance of the testis is so extreme that no real reversal of the ovary occurs, only an almost complete suppression and sterility. This type of response is seen, for example, in parabolic pairs of the wood frog (Witschi, 1927) and in the newt *Triturus* (Witschi and McCurdy, 1929), and is probably correlated with a constitutional inadequacy of the medullary component in the embryonic ovaries of the species in question. In other species, on the other hand, a severe initial repression of the ovary is followed by a delayed reversal, which may have a prolonged course but which eventually may be quite complete. In parabolic pairs of certain species of *Ambystoma* (Fig. 2.7) there is a severe inhibition of the ovary before active transformation is initiated, and when rever-



FIG. 2.7. An extreme degree of inhibition and reduction in certain regions of an ovary under the dominance of a well developed testis (Humphrey, 1942). *A.* Level showing sterile medulla above, with degenerate cortical zone below. *B.* Medulla with rete cord and a single germ cell above, small cortical remnant below. *C.* Region showing complete atrophy. (From Biological Symposia, Vol. IX, Jacques Cattell Press, Lancaster, Pa.)



FIG. 2.8. Sections through a transforming ovary in an older case. The cortex is extremely reduced and the medullary area is well differentiated as a testis. In *B*, except for the cortical remnant, the histologic picture is that of a normal testis of intermediate development, with well defined lobules (Humphrey, 1942; cf. Fig. 2.7).

sal begins it may be confined to local regions of the ovary. Transformation may set in independently at several sites, resulting in localized masses of testicular tissue which are, however, histologically normal (Fig.

2.8). Ultimately all remnants of cortex disappear and transformation is complete. Such individuals are capable of breeding as males (this depends on the new testis establishing proper connections with the duct system)

notwithstanding they have the genotype of the opposite sex (for a discussion see Humphrey, 1942).

To insure invariable predominance of the ovary in sex reversal it is usually necessary to provide a marked advantage in size and rate of development in favor of the female. This can be done experimentally by resorting to heteroplastic combinations (Fig. 2.9). In parabiotic pairs composed of two species of very different size (e.g., *Ambystoma tigrinum*-*Ambystoma maculatum*) and with a corresponding difference in growth rate, when the members are of different sex the larger species is almost invariably dominant (Fig. 2.11; Burns, 1935). When the large partner is a female the ovaries are enormously larger than the testes of the male and are always normal. The testes in some cases undergo reversal almost from the beginning of differentiation, and toward metamorphosis are represented by very small ovaries which contain a few well developed oocytes. However, in most indi-

viduals transformation sets in after considerable differentiation has occurred, the testis cords becoming hollowed out to form ovarian sacs (Fig. 2.11) while the cortex persists and grows rapidly. At metamorphosis males are either completely transformed or the process is far advanced. Complete transformation of this type has also been reported by Witschi (1937) in *A. tigrinum*-*A. jeffersonianum* pairs.

A similar result is obtained when single gonad primordia are transplanted heteroplastically by Humphrey's method (Fig. 2.4). In individuals bearing gonads of different sex, when the ovary is of the larger species it is dominant regardless of whether it belongs to the host organism or was derived from the graft. Histologically the reversal process is the same as in parabiotic pairs (Humphrey, 1935a, b). For fuller discussions of species and racial differences as they affect physiologic sex dominance and the capacity of the gonads to undergo reversal in different species see Witschi (1934,



A



B

FIG. 2.9. Heteroplastic combinations uniting different species of salamander (*Ambystoma tigrinum* and *A. punctatum*) which differ greatly in eventual size and rate of growth. A. Ventral view of paired embryos just after operation, showing fusion in the cervical region (punctum member at left). B. A pair after metamorphosis showing the great difference in size: the larger animal is the *tigrinum* member.

1957). Humphrey (1942), and Gallien (1955).

The progress of sex reversal, and the mechanism by which the transformation is effected, can be analyzed histologically only when it takes place as a secondary process, after a certain amount of sex differentiation has previously occurred. In this case both histologic components are distinctly represented but the normally recessive component seeks to become dominant; ovaries become testes by regression of the differentiated cortex accompanied by growth and differentiation of the medullary element (Figs. 2.8 and 2.10), and testes are converted into ovaries by the reverse process (Figs. 2.6C' and 2.11A-D). The mechanism is flexible, however, and there is much variability, even among individuals in the same experiment, with respect to the stage at which reversal sets in, its progress, and its final outcome. In some cases removal of the dominant gonad after reversal is far advanced may be followed by a second reversal toward the original sex (Humphrey, 1942).

However, transformation is not always a

secondary process, set in action only after a certain amount of differentiation has already occurred; as noted above, when the quantitative disparity between the interacting gonads is sufficiently marked reversal may proceed from the earliest stages of differentiation. In this case the term "reversal" is less apt since there were no previous histologic steps to be retraced. Transformation is indicated chiefly by the unbalanced sex ratios at the end of the experiment; but in certain cases it is confirmed by characteristic histologic peculiarities (Burns, 1935, Fig. 28; Witschi, 1937, Fig. 39). In the heteroplastic grafting experiments of Humphrey, on the other hand, direct proof is available since in many cases the sex of the grafted gonad, although conforming with that of the host, differs from the sex of the donor animal which is reared to provide a direct control.

Although primary reversal of sex differentiation, as described above, occurs more readily when a marked disparity in size leads to early dominance, it may also occur under conditions which greatly retard de-



FIG. 2.10. Two views of an ovary of *Ambystoma tigrinum* undergoing reversal under the influence of the testes of a male partner. The cortical zone, with characteristic early oocytes, is still prominent; however, medullary development is proceeding and in the region represented in B, testis lobules are forming. (From R. K. Burns, *J. Exper. Zool.*, **55**, 123-129, 1930; **60**, 339-387, 1931.)

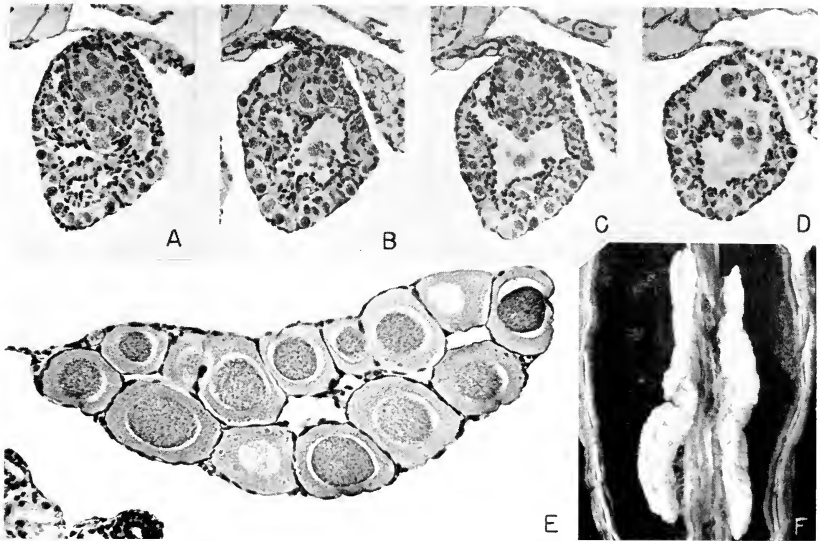

FIG. 2.11. Stages in the transformation of testis to ovary in the male (punctatum) member of an *Ambystoma tigrinum*-*A. punctatum* pair, joined in heteroplastic parabiosis (Burns, 1935). A to D show, at successive levels in the same gonad, the degeneration of the medulla by vacuolation of the rete canals and lobules, accompanied by persistence and growth of the cortex. E shows a section through one of the dominant and entirely normal tigrinum ovaries; a gross picture of these ovaries is seen in F. (From R. K. Burns, *Anat. Rec.*, **63**, 101-129, 1935.)

velopment and delay the beginning of sex differentiation. This appears to be the case in the first parabiosis experiments (Burns, 1925) in which the method of joining interfered with feeding and resulted in a severe retardation of growth. Such pairs developed so slowly that sex differentiation was delayed for weeks and in many cases for months. When it eventually took place members of a pair were almost invariably of the same sex (*cf.* Humphrey, 1932) although there was great variation in the size and stage of differentiation of the gonads. In this experiment the usual physiologic dominance of the male was also disturbed, male-male and female-female pairs appearing in nearly equal numbers.<sup>4</sup> The manner

<sup>4</sup>The author's interpretation of the results in this experiment has often been questioned by Witschi. However, all but a small part of this material was subsequently re-examined by Humphrey (1932) whose study confirmed the original conclusions except for minor details involving at the most only eight pairs. In Humphrey's opinion there were certain histologic indications that these

in which extremes of temperatures induce sex reversal in tadpoles through a differential inhibitory effect on the medullary or the cortical component of the embryonic gonad has been referred to earlier. The above result may have a similar physiologic basis if, under prolonged repression, the usually dominant male gonad should prove to be more susceptible to unfavorable conditions than the female.

### 3. Administration of Steroid Hormones

Since sex hormones of adult type became available in pure form their effects on the differentiation of sex have been tested in many species of amphibia. They are readily administered in two ways, by injecting directly into the body cavity or, in aqueous solution, by adding them to the water in which the larvae are reared. The results on the whole are striking; in certain species there

pairs were originally heterosexual, although transformation had proceeded to the point where a complete reversal was imminent.

is complete transformation of ovary to testis or of testis to ovary, and in some cases the transformed individuals have been proved functional and capable of breeding. In other species, however, negative, equivocal, and in many cases paradoxical results have been obtained by the use of the same substances. A hormone that completely transforms all individuals of the opposite sex in one species may have only a weak or impermanent effect in another, or no effect at all in a third. Obviously the gonads of different species differ greatly in their responses to steroid hormones. There is also a correlation with sex. In some species the gonad of one sex undergoes reversal with relative ease whereas that of the other is difficult or impossible to transform, although increased dosages are sometimes effective. In certain species in which the sex chromosome complex is known it is the *homogametic sex* that is readily reversible (Gallien, 1955). It is also clear that experimental conditions strongly influence the result. The time factor, that is to say the stage of differentiation at which treatment is initiated, is obviously important; in general, the most complete transformations are obtained when the hormone has been present from the beginning of the differentiation process. Dosage is likewise of great importance and the optimal dosage varies greatly from one species to another. A negative response at one dosage may become positive when the dosage is increased; on the other hand, strong "paradoxical effects" (stimulation of the characters of one sex by the hormone of the other) are often encountered with high dosages which are absent at lower levels. At present it is not possible to give consistent explanations for all such contradictory results; however, better understanding is gained when they are classified into convenient categories.

*The effects of male hormones on sex differentiation in frogs.* On the whole, the most successful reversals obtained by the use of steroid hormones have been in frogs of the family *Ranidae*, of which some six species have now been studied with similar results. Both male and female hormones induce reversal of sex in young tadpoles, but male hormones are more effective and far more consistent in their effects. In *Rana tempo-*

*riana* treatment with testosterone propionate transforms all genic females into males. The transformation is complete and permanent; moreover, transformed individuals are capable of functioning in their new capacity (Gallien, 1944). A similar transformation has been obtained in *Rana sylvatica*, a phenomenonally low concentration of the hormone (1/500,000,000 parts dissolved in the aquarium water) inducing complete histologic transformation (Mintz, 1948). Comparable results have been reported after use of the male hormone in several other species of this genus (Table 2.1). In the case of *Rana catesbeiana* it was found necessary to "prime" the gonads by simultaneous treatment with gonadotrophin, otherwise they were unresponsive; when so treated, however, complete transformation is obtained. The gonadotrophic substance alone initiates a precocious differentiation of sex but without any tendency to transformation, serving only to precipitate the normal differentiation process. Complete and permanent masculinization of females by testosterone propionate has also been reported recently in a tree frog, *Pseudacris* (Witschi, Foote and Chang, 1958), and a virtual transformation at the age of metamorphosis in *Rhacophorus* (Iwasawa, 1958), indicating that other anuran families may resemble the *Ranidae* in their reactions to the male hormone. In marked contrast, male hormone is without effect on gonad differentiation in the toad (Chang, 1955).

*The effects of female hormones in the Ranidae.* These are variable and less conclusive. The results frequently depend on dosage and the effective dose may vary greatly in different species. Estradiol benzoate in weak doses has a slightly feminizing action in male tadpoles of *Rana temporaria* (Gallien, 1941), but stronger doses produce complete feminization in an "undifferentiated race" (one in which sex differentiation of males occurs relatively late) of the same species, all tadpoles at metamorphosis being females (Gallien, 1940, 1955). It is noteworthy that in this case both genic constitution (race) and the dosage of the hormone may be factors in the result. In other ranid species estradiol, administered in *low dosages* during the period of sex differentiation, has a completely feminizing effect; at meta-



TABLE 2.1

The effects of synthetic male and female sex hormones on the differentiation of the gonads in various species of amphibians.

The cases listed are those in which a complete, or near complete, and histologically normal transformation was achieved by the age of metamorphosis. In some species the reversal was permanent and functional. For details see text.

## ACTION OF MALE HORMONE ON FEMALES

SPECIES	INVESTIGATORS	RESULT	COMMENT
RANA TEMPORARIA	GALLIEN 1938, 1944	COMPLETE TRANSFORMATION	PERMANENT AND FUNCTIONAL
RANA SYLVATICA	MINTZ 1948	COMPLETE TRANSFORMATION AT METAMORPHOSIS	DOSAGE 1/500 000 000 IN ACQUARIUM WATER
RANA PIPIENS	FOOTE 1938	COMPLETE TRANSFORMATION-TREATMENT FOR 65 DAYS	
RANA CATESBIANA	PUCKETT 1939, 1940	COMPLETE TRANSFORMATION AT METAMORPHOSIS	ADMINISTERED WITH GONADOTROPIN
RANA CLAMITANS	MINTZ, FOOTE & WITSCHI 1945	COMPLETE TRANSFORMATION-TREATMENT FOR 95 DAYS	SOME PRODUCED SPERM
RANA AGILIS (DALMATINA)	VANNINI 1941; PADOA 1947	COMPLETE TRANSFORMATION	
PSEUDACRIS NIGRITA	WITSCHI, FOOTE & CHANG 1958	COMPLETE TRANSFORMATION	EFFECT PERMANENT
RHACOPHORUS SCHLEGELII	IWASAWA 1958	TRANSFORMATION ALMOST COMPLETE	AT THE AGE OF METAMORPHOSIS

## ACTION OF FEMALE HORMONE ON MALES

PLEURODELES WALTLII	GALLIEN 1954	COMPLETE TRANSFORMATION	PERMANENT AND FUNCTIONAL
XENOPUS LAEVIS	GALLIEN 1953	COMPLETE TRANSFORMATION	PERMANENT AND FUNCTIONAL
RANA TEMPORARIA	GALLIEN 1941, 1944	COMPLETE TRANSFORMATION	EFFECT NOT PERMANENT
RANA ESCULENTA	PADOA 1938, 1942	COMPLETE TRANSFORMATION AT METAMORPHOSIS	AT LOW DOSAGES ONLY
RANA SYLVATICA	WITSCHI 1952, 1953	COMPLETE TRANSFORMATION AT METAMORPHOSIS	AT LOW DOSAGES ONLY
RANA CATESBIANA	PUCKETT 1939, 1940	COMPLETE TRANSFORMATION AT METAMORPHOSIS	ADMINISTERED WITH GONADOTROPIN
BUFO AMERICANUS	CHANG 1955	COMPLETE TRANSFORMATION AT METAMORPHOSIS	EFFECT NOT PERMANENT

morphosis all tadpoles are females (Table 2.1). This result has been reported in *R. esculenta* (Padoa, 1942), in *R. sylvatica* (Witschi, 1951, 1952, 1953), and Puckett (1939, 1940) obtained the same effect in *R. catesbiana* when a gonadotropin was given simultaneously with the estrogen. However, such transformations, although histologically complete, are not in all cases permanent (Gallien, 1955); moreover, the effects of high dosages of the same hormone may be quite different, as will be shown. For other species only partial transformations have been found, as in *R. clamitans* (Mintz, Foote and Witschi, 1945) and in *R. pipiens* (Foote, 1938). A similar type of incomplete transformation by the female hormone has recently been reported in the tree frog, *Pseudacris* (Witschi, Foote and Chang, 1958), again suggesting that in their pattern of response to sex hormones the *Hylidae* resemble the *Ranidae*.

Various other anuran species have yielded divergent results. In the primitive frog,

*Xenopus laevis*, complete and functional transformation of males is effected by an aqueous solution of estradiol benzoate (Gallien, 1953), and in the toad (*Bufo americanus*, Chang, 1955) low doses of estradiol completely transform testes into ovaries although high doses have little effect. Finally, in *Discoglossus* the effect of estradiol is purely feminizing but the transformation is incomplete, the males exhibiting all degrees of intersexuality without obvious relation to dosage (Gallien, 1955).

*Paradoxical effects.* Thus far emphasis has been placed chiefly on cases in which sex hormones have acted in a sex-specific manner, each type of hormone directly or indirectly promoting the development of structures of the appropriate sex, while inhibiting or behaving in neutral fashion toward those of the other. Reference has been made more than once, however, to the fact that in other cases the effects are just the reverse of theoretical expectation and opposed to the concept of hormones as specific

sex-differentiating agents. Anomalous or paradoxical results of this kind have appeared in experiments with both types of hormone, and involve not only the gonads but other sex structures as well.

Such a result was first reported by Padoa (1936) who found that a crystalline form of female hormone (Crystallovax) had a strong masculinizing effect on the sexual differentiation of tadpoles of *Rana esculenta*, all gonads developing as testes. This unexpected result (the so-called "paradoxical effect") was confirmed by others and has been found to be usually associated with the use of high dosages. In the course of time it was shown in this and in two other species (*Rana temporaria*, *Rana sylvatica*) that the same hormone (estradiol) may have diametrically opposite effects when administered in different dosages. As was emphasized earlier, low doses have a proper feminizing action, producing all female individuals according to theoretical expectation; with high dosages, on the contrary, only males are obtained, and at intermediate levels all individuals become intersexual (Padoa, 1938, 1942; Gallien, 1941, 1955; Witsehi, 1952, 1953). Indeed, identical amounts of the same substance may have opposite effects when different solvents are employed. Administered in oil the effect on the gonads is feminizing but in aqueous solution complete masculinization occurs (Gallien, 1941). This also would appear to be a dosage effect since in aqueous solution the rate of uptake is presumably much faster than in oil. There are no histologic indications in the above experiments as to how the paradoxical effect is mediated. But, although such effects are found in various rapid species, they do not occur in *Discoglossus* regardless of dosage, thus emphasizing the importance of species differences in the phenomenon (Gallien, 1955).

Male hormones also produce paradoxical effects on the gonads and, although the doses employed have generally been high, it again appears that the result often depends on the species tested. The same dose of the same substance may have opposite effects in different species. Testosterone or ethinyl-testosterone in large doses have strong feminizing effects on the testes of the salamander *Pleurodeles*, whereas the devel-

opment of the ovaries is retarded but otherwise unaffected, a typical paradoxical effect (Gallien, 1950, 1955). Ethinyl-testosterone has the same effect in *Discoglossus*, but in *Rana temporaria* this hormone has only the expected masculinizing action. Such differences in response may arise from differences in sensitivity on the part of the gonads or gonad components; a dose which is relatively large for one species may not be so in the case of another.

The effects of sex hormones in urodele amphibians. In urodele amphibians the effects of sex hormones on the differentiation of the gonads are perhaps even more variable; however, as opposed to the situation in the *Anura*, it is the female hormones which are more effective in producing reversal than the male (Gallien, 1955). In only one instance, the newt *Pleurodeles*, has a functional transformation of sex been achieved (Gallien, 1954). In this species prolonged treatment with estradiol benzoate completely reverses the differentiation of all males, some of which become capable of laying eggs. Varying degrees of transformation have been reported in other urodele genera after shorter periods of treatment, in *Ambystoma* (Burns, 1938a; Aekart and Leavy, 1939; Foote, 1941) and in *Hynobius* (Hanaoka 1941a). There was great variation in the timing of treatment and in the dosages employed in these experiments; the incomplete character of the reversal may be due in part to such factors, but the role of species variability must also be great.

On the other hand the male hormone, in marked contrast to its dominating role in the *Anura*, has but a limited transforming action in *Urodeles*. Indeed, it frequently, but not always, produces paradoxical effects (cf. Burns, 1939c; Foote, 1941; Bruner, 1952). In *Pleurodeles*, in which the males are completely transformed by estradiol, the effect of testosterone is limited to a severe inhibition, which affects the gonads of both sexes but is more extreme in males (Gallien, 1955). Medullary development is almost completely suppressed, and after an interval of recovery the vestigial gonads give rise almost exclusively to rudimentary ovaries, a result mentioned previously in discussing paradoxical effects. In this case, however, there is clear histologic evidence as to how

the effect is mediated. Reversal is caused indirectly by a severe inhibition of mesonephric development. Since the sex cords which give rise to the medulla of the testis are derived from the mesonephric blastema, inhibition of this tissue prevents their formation. In the absence of proper medullary development, the cortical rudiment of the testis eventually becomes active to produce an ovary. This, apparently, is another example of spontaneous differentiation of the heterotypic gonad component when released from domination.

A summary of the effects of steroid hormones in amphibians. Sex hormones of adult type, such as testosterone and estradiol, have effects which vary greatly in different taxonomic groups of amphibians and also according to experimental conditions, such as dosage, timing, and duration of treatment. In many species their effects are specific to a degree, closely simulating the effects expected of natural hormones. Histologically complete and in some cases functional transformations of the gonads have been produced in a number of species, involving two orders and several families (Table 2.1). Nevertheless, in other species only partial or temporary reversals are obtained, and negative or even paradoxical results have come from use of the same hormones. Constitutional differences between taxonomic units obviously underlie some of the conflicting results. Sex genotype is also involved, because in a particular species reversal may proceed easily in one direction whereas in the other it is difficult or impossible to produce. Following in part Gallien (1955), the results may be tentatively grouped as follows:

a. In the higher anurans of the family *Ranidae*, and perhaps also in the *Hylidae*, the male hormone induces complete, and in many species a permanent reversal of sex. The action of female hormones on the contrary is highly variable; transformation may be incomplete or unstable, and with high dosages paradoxical or masculinizing effects often appear. On the other hand, low doses of the same hormone have in many cases proper feminizing effects in the same species. In one species (*Rana caucasiensis*) complete reversal of sex in both directions has been obtained.

b. In certain *urodeles* and *lower anurans*, female hormones induce a transformation of male gonads which may be complete and stable, as in *Pleurodeles* and *Xenopus*, or partial, as in *Discoglossus* and various species of *Ambystoma*. The extent to which partial reversals are attributable to particular experimental conditions is uncertain. Male hormones in general are much less effective, and are prone to induce a paradoxical inhibition or a feminization of the testis. These effects have in some cases been shown to be mediated indirectly, through an inhibition of nephrogenesis which suppresses the differentiation of the medullary sex cords. The paradoxical effects of female hormones, on the other hand, are in many cases a matter of high dosages; how such effects are exerted is unknown but the action is probably indirect. This point will be discussed elsewhere in connection with the problem of paradoxical effects on other sex structures.

### C. SEX REVERSAL IN AVIAN GONADS

#### 1. Organization of Avian Gonads

In avian as in amphibian gonads a specific morphologic basis for sex reversal exists during early development in the form of medullary and cortical components which have the usual potentialities. In birds, however, the situation is complicated by the peculiar lateral asymmetry which affects in some degree the entire genital system and which is especially pronounced in the female of most species (Fig. 2.12). The summary which follows is based primarily on the chick (for a fuller account see Willier, 1939). In the left embryonic ovary the preponderance of the cortex is great, even in the early stages, whereas in the rudimentary right ovary the cortex is essentially absent, being briefly represented by a transient germinal epithelium which disappears even earlier than that of the testis (Wolff, 1948). In fact, the right ovary virtually ceases to develop at a stage when only medullary tissue (primary sex cords) has been laid down. In the male the asymmetry is morphologically less marked but it is expressed nevertheless in the better development and longer survival of the germinal epithelium (potential cortex) on the left testis. The

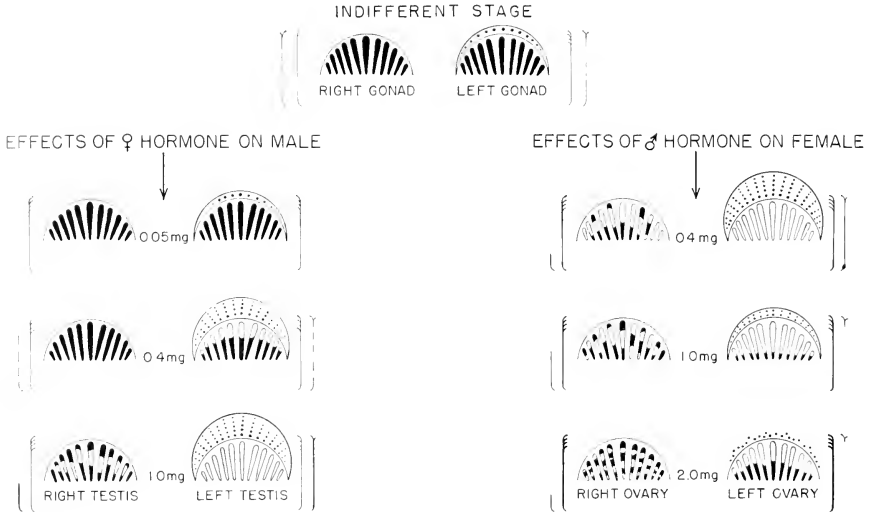

FIG. 2.12. Diagrams showing lateral differences in gonad organization in the chick embryo with respect to the representation of cortical and medullary elements; and differences in reaction to sex hormones based on these differences. (After N. T. Spratt, Jr., and B. H. Willier, *Tabulae Biologicae*, **17**, 1-23, 1939). Note the stronger representation of the cortical component in the left gonad in both sexes, and its influence on the responses of gonads to hormones in relation to dosage. For details see text.

structural differences are correlated with different capacities for sex reversal under experimental conditions, as will appear.<sup>5</sup>

The experimental study of sex differentiation in birds has been limited largely to two domestic species, the chick and the duck. Histologic sex differences first appear in the gonads of these species around the seventh and the ninth days of incubation, respectively, but the future pattern of development is essentially determined much earlier. This is shown by the fact that when the sexually indifferent gonads of chicks are transplanted at the *genital ridge stage* to the chorioallantoic membrane of another embryo, they continue in most cases to develop independently, in accordance with genotype, giving rise to typical testes or ovaries, and in the case of gonads of female constitution to characteristic right or left ovaries as well

<sup>5</sup>The spontaneous reversal of sex that frequently follows removal of the dominant left ovary in the young female chick is an example, and the basis for this phenomenon lies in the predominantly medullary character of the rudimentary right ovary as described earlier.

(Willier, 1933, 1939). The same capacity for self-differentiation has been demonstrated under the more radical conditions of isolation. Histologically undifferentiated gonads of either species when cultured *in vitro* differentiate into testes, or into right and left ovaries of characteristic structure (Wolff and Haffen, 1952a). In some cases there is injury to the germinal tissue under culture conditions; the gonads may show a reduction in the number of germ cells, or in some cases complete sterility, but otherwise the structure is normal (Fig. 2.13). Duck gonads seem to be more hardy under conditions of culture than those of the chick, and in general show better growth and histologic differentiation.

## 2. Effects of Administering Pure Hormones

As noted earlier, sex reversal in the gonads of birds was not demonstrated experimentally until pure hormones became available. The first successful experiments were those of Kozelka and Gallagher (1934); Wolff and Ginglinger (1935); Willier, Gal-

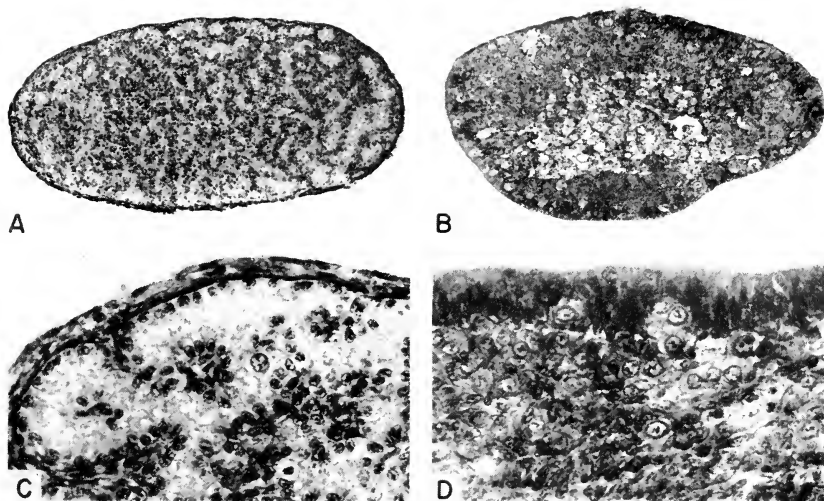

FIG. 2.13. Histologic differentiation in the gonads of duck embryos developing *in vitro*, after isolation just at the beginning of sexual differentiation (Wolff and Haffen, 1952a). A. Normal form and histologic differentiation of the testis in comparison with an ovary developing under the same conditions (B). C and D show, respectively, the structure of these gonads under higher magnification. (From Et. Wolff and K. Haffen, *J. Exper. Zool.*, **119**, 381-404, 1952.)

lagher and Koch (1935, 1937); and Dantchakoff (1935, 1936) who introduced steroid hormones into incubating eggs before the beginning of sex differentiation. The results vary in detail but are consistent in the main outlines; they may be stated briefly, following chiefly the reports of Willier, Gallagher and Koch and of Wolff and Ginglinger.

*Female hormones* (estrone or estriol) do not significantly affect the differentiation of embryonic ovaries but testes are highly transformed. Because of the better development and longer survival of the germinal epithelium the left testis is more amenable to reversal than the right. Relatively low doses convert it into an ovotestis. The distal ends of the medullary cords become hollowed out into tubular structures like the medullary cords of the ovary (Fig. 2.14A); at the same time a zone of cortex develops peripherally, arising as a proliferation of the germinal epithelium. A small, unchanged medullary mass usually persists at the hilus. But with larger doses even this may disappear and the cortex becomes much thicker.

Such cases are practically indistinguishable from ovaries. The right testis, however, is more difficult to transform. In the above experiments it was not greatly modified at lower dosages; even when the left testis was almost completely transformed into an ovary the right never entirely lost its testicular character. Because of the poor development of the germinal epithelium its capacity to produce cortex is limited. However, Wolff (1948) made a special study of the right gonad in both sexes, assuming that stimulation of the gonad at an earlier stage, before regression of the germinal epithelium can be detected in either sex, might reveal a greater capacity for cortical differentiation. To insure rapid action a water soluble form of the hormone was used. In this way a considerable differentiation of cortex was obtained. The importance of a persistent search for the proper experimental conditions is again demonstrated.

*Male hormones*, on the other hand, are less effective in transforming the embryonic ovaries of birds. Again lateral differences

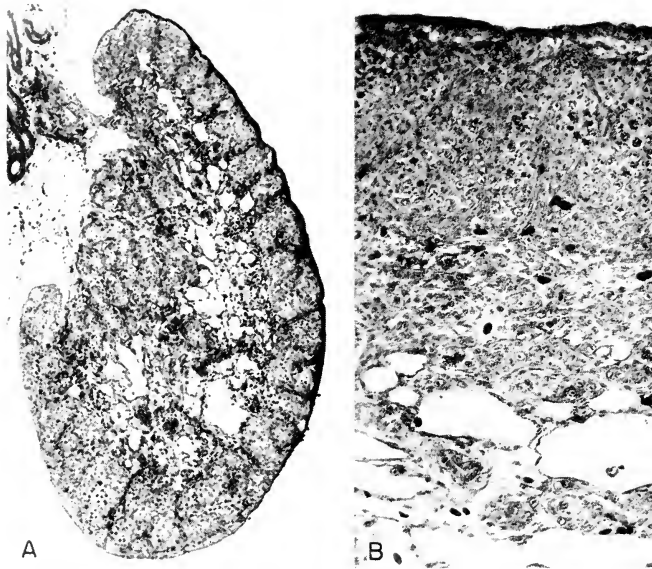

FIG. 214. Histologic sex transformation in the testes of chick embryos treated with female sex hormones. *A*, Ovotestis produced from a left testis by treatment with a dose of 0.2 mg. of estriol. Note the presence of a thick cortex peripherally, and the reduction of the testicular tissue to a hilar mass of medullary cords. The intervening highly vacuolated tissue is characteristic of ovarian medullary cords. *B*, Section through the cortex and medullary region of a left testis completely transformed into an ovary by a dose of 2.0 mg. of estrone. Note the thick cortex (above) covered by a germinal epithelium, and the loss of structure in the medullary region below. (From B. H. Willier, in *Sex and Internal Secretions*, 2nd ed., The Williams & Wilkins Co., 1939.)

reaction are found due to the different histologic constitution of the right and left primordia, and the results also differ when different forms of the male hormone are employed. After treatment with testosterone the cortex of the left ovary is reduced in thickness and shows degenerative changes; however, it does not entirely disappear. At the same time there is hypertrophy of the medulla and some of its cords acquire the solid structure of testis cords. The result is an ovotestis. Because of its predominantly medullary constitution the rudimentary right ovary is converted superficially into a testis-like gonad. The medullary mass hypertrophies and some of the cords are transformed into testis cords. In general, larger amounts of hormone are required to transform ovaries than for the conversion of testes (for summaries see Willier, 1939;

Wolff, 1950). After hatching there is a tendency for experimentally modified gonads to revert toward the original sex (Wolff, 1938). Similar conditions of reversal have been produced in the embryonic gonads of ducks by hormone treatment (Lewis, 1946).

The problem of the paradoxical action of hormones presents itself again in the case of avian gonads. Certain male hormones of urinary origin (androsterone, dehydroandrosterone) have a marked feminizing effect, like that produced by female hormones. In relatively large doses both substances induce cortical differentiation in testes, especially the left, which may be transformed into an ovotestis (Willier, 1939; Wolff 1938). Other androgenic substances have like effects, but again it has been shown that they are not produced by low dosages. However, as the concentration of the hormone is raised

the degree of intersexuality and the number of intersexual gonads steadily increase (Wolff, Strudel and Wolff, 1948). Since various accessory sex structures also show paradoxical reactions the problem will appear again.

### 3. *Effects of Grafting Gonads into the Coelomic Cavity*

The demonstration that steroid sex hormones are capable of inducing sex transformation in avian gonads led to a reinvestigation of earlier failures to obtain reversal by means of chorioallantoic grafting. Eventually it was shown that the difficulty was largely a matter of the method. When gonad primordia are transplanted directly into the coelomic cavity of a host embryo of different sex, varying degrees of transformation, or even a virtual reversal, are obtained.

The first experiments of this type were only a partial success (Bradley, 1941). Embryonic gonads of the chick and the duck, isolated at 96 to 120 hours of incubation, were inserted into the body cavity of host embryos through a small slit in the somatopleure, using both homoplastic and heteroplastic host-graft combinations. In the case of the chick, host embryos were always considerably younger than donors. In all cases the grafts underwent primary sex differentiation in accordance with genotype, and only a small minority showed specific modifications. The results were rather inconclusive because in no case were the changes of a conspicuous character, and there was great variability in the growth and differentiation of the grafts, making it difficult to assess the significance of the modifications. In some cases changes of the same type appeared in the gonads of the host embryo.

The modifications noted by Bradley fall into three main classes. (1) Vacuolation of the medullary cords of testes growing in female hosts (in a few cases) caused them to resemble the hollow medullary cords of ovaries. (2) In some cases ovaries growing in male hosts developed solid medullary cords of male type. (3) Rudimentary right ovaries (always testis-like in character) had a tendency to become enlarged when growing in male hosts. A similar effect was sometimes seen in the right ovaries of hosts bear-

ing testis grafts. No ready explanation was available for the inconstant occurrence of these effects or for their quantitative variability, because no clear correlation was found between the degree of modification and the relative proximity of the interacting gonads. Finally, similar changes appeared in a few cases when the host-graft combinations involved the same sex; consequently the specific character of the modifications was left in doubt.

The matter was clarified by the experiments of Wolff (1946) who used a modification of the method with better results. Grafts taken from older embryos (6 to 11 days) were implanted into hosts of about 50 hours of incubation. Under these conditions a striking transformation of gonad differentiation was obtained in the host, and in addition the developing gonaducts (*q.v.*) were strongly modified. Ovaries grafted into male hosts induced differentiation of cortex on the left testis to such an extent that it sometimes approached the structure of an ovary. The right testis (which was usually more distant from the graft) was less modified but its growth was inhibited. On the contrary, implantation of a testis in the same manner produced no important effect on the differentiation of the ovaries of the host but the development of the Müllerian duct was strongly inhibited indicating that the graft is endocrinologically active. In their histologic character the effects of gonad grafts are similar to those produced by crystalline hormones, differing only, as a rule, in being more localized in relation to the position of the graft. The demonstration in this experiment that, physiologically, the ovary is the dominant gonad in birds is consistent with the earlier observation that relatively larger doses of pure hormones are required for the transformation of ovaries than for testes.

These positive results after so many failures suggested that the ineffectiveness of chorioallantoic grafts in the earlier experiments was possibly a matter of hormone production, failure of the graft to maintain a sufficient level of the hormone in the blood. This view is substantiated by the later experiments of Huijbers (1951) who showed that multiple grafts of well differentiated testes on the chorioallantois have managed

effects on the accessory sex structures of the host, similar to those induced by intra-embryonic grafts.

#### 4. Sex Reversal *in Vitro*

More recently the technique of culture *in vitro* has been employed by Wolff and his collaborators with great success to study the development of embryonic gonads, and it has been possible to produce typical reversal of sex differentiation *in vitro* by two methods. Prospective ovary and testis of the chick or duck, isolated at the very beginning of sex differentiation and placed in close contact in the culture dish,<sup>6</sup> become firmly fused, facilitating the transmission of humoral influences. As in the case of gonad grafts in the coelomic cavity, the ovary under such conditions proves to be the dominant gonad (Wolff and Haffen, 1952b). It readily induces cortical differentiation on the testis, which becomes an ovotestis, and may even approximate closely the structure of a normal ovary of the same age (Fig. 2.15). The same type of transformation occurs in testes after introduction of estradiol benzoate into the culture medium.

With respect to the histologic character of the reversal process, the resemblances between the effects of gonad grafts implanted in the body cavity, crystalline hormones injected into the whole organism, and the results of the same procedures applied to isolated gonad primordia *in vitro* are extremely close. The *in vitro* studies demonstrate again the autonomous character of the differentiation process, and its flexibility in the presence of extraneous hormones is shown to be independent of the organism as a whole. Hormones *in vitro* evidently act directly on the gonad mechanism.

#### D. THE PROBLEM OF SEX REVERSAL IN MAMMALIAN GONADS

##### 1. Bisexual Potentialities in the Embryonic Gonads of Mammals

In marked contrast with the striking effects of steroid sex hormones on the differentiation of the gonads of birds and various

species of amphibians has been the failure thus far to obtain comparable effects in mammalian embryos with the exception of a single species, the North American opossum, a marsupial. Essentially negative results have been reported for a number of species of placental mammal, in which pregnant females were treated with relatively large dosages of sex hormones during the period of sex differentiation. Experiments of this type were carried out in the rat by Greene, Burrill and Ivy (Greene, 1942), and in the guinea pig (Dantchakoff, 1936, 1937), the mouse (Turner, 1939, 1940; Raynaud, 1942), the rabbit (Jost, 1947 a), the hamster (Bruner and Witschi, 1946; White, 1949), and the monkey (Wells and van Wagenen, 1954). With the single exception of the opossum (to be described later) the modifications induced are minor in character and are of three types: (1) a general retardation of growth and development of the gonads, without obvious signs of sex reversal, which occurs in both ovaries and testes and may be produced by either type of sex hormone;<sup>7</sup> (2) a variable degree of hypertrophy of the medullary elements of ovaries after treatment with male hormone, reported in only a few cases (Dantchakoff, 1939; Jost, 1947a; Wells and van Wagenen, 1954); and (3) the occasional persistence of localized patches of germinal epithelium on the surface of well differentiated testes, a condition which sometimes appears after treatment with either type of sex hormone. Minor changes of this character have not generally been accepted as convincing evidence of sex reversal.

Notwithstanding this array of negative findings, the failure of the embryonic gonads of placental mammals to respond definitely to sex hormones can hardly be attributed to an inherent lack of bisexual potentiality. During the early stages of their development they show, histologically, the same evidences of bisexual structure as the gonads of other vertebrates, although typically the bisexual phase is of relatively brief duration and the recessive sex com-

<sup>6</sup>Combinations of gonads in the culture dish must initially be made at random but the other gonad of each donor is cultured separately in order to establish its sex.

<sup>7</sup>This effect is of common occurrence and is best explained as a depression of the gonadotrophic function of the anterior pituitary, a mechanism which is well established in adult organisms (Moore and Price, 1932).



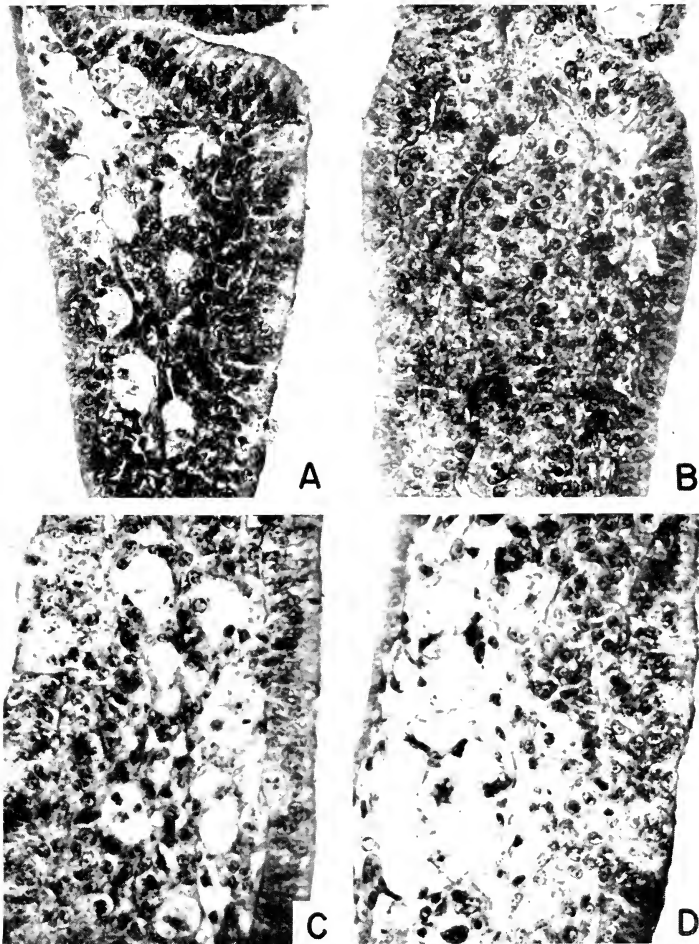

FIG. 2.15. Sex transformation in the testis of the duck, isolated *in vitro* at the beginning of sexual differentiation and cultured in close contact with an embryonic ovary (Wolff and Haffen, 1952b). *A*. The ovary of such a combination, showing the thick covering germinal epithelium and the vacuolated condition of the medullary region. This young ovary is essentially normal in structure. *B*. Intersexual condition induced in the testis under the influence of the ovary. The heavy germinal epithelium representing the cortex is as well developed as in a normal ovary; the medullary region retains largely the compact structure of a testis, but signs of vacuolation are appearing. This gonad is an ovotestis. *C* and *D* represent, respectively, the ovary and the completely transformed testis in another experiment. The two gonads in this case show almost identical structure, featuring the thick cortex and vacuolated medulla of an ovary. In these experiments the other testis, cultured alone, developed normal testicular structure. (From Et. Wolff and K. Haffen, *Arch. Anat. Microscop. et Morphol. expér.*, **41**, 184-207, 1952.)

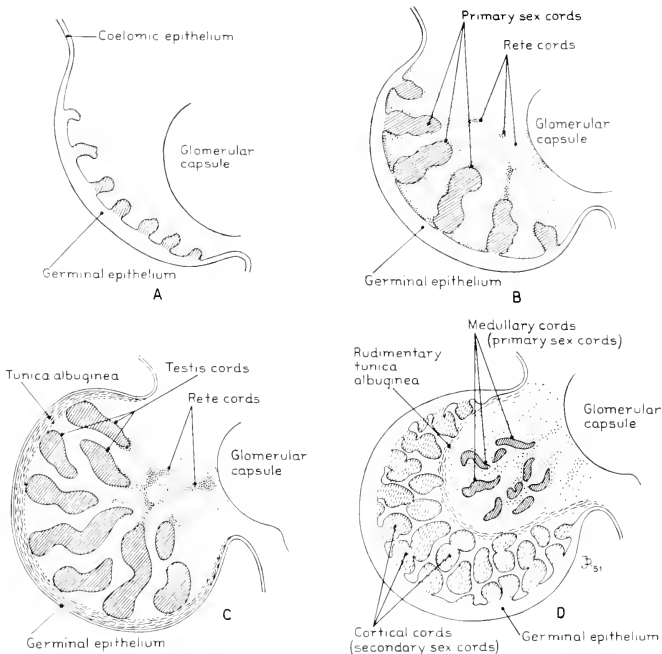

FIG. 2.16. Diagrams illustrating schematically the main features of gonad differentiation in amniote embryos with reference to the origin of the medullary and cortical components. *A*. Origin of the primary sex cords (medullary cords) from the germinal epithelium. *B*. Gonad at the indifferent stage of sexual differentiation; the well developed primary sex cords represent the male or medullary component, whereas the germinal epithelium represents, potentially, the cortical component. *C*. Differentiation of a testis consists in the further development of the primary sex cords, and the reduction of the germinal epithelium to a thin, serous membrane, accompanied by development of the tunica albuginea. *D*. Differentiation of an ovary consists in reduction of the primary sex cords to medullary cords of the ovary, whereas the cortex is formed by continued development of cortical cords from the germinal epithelium.

ponent is often weakly represented (Fig. 2.16). In the ovary, medullary cords representing the male component are present but tend to become vestigial in most species.<sup>5</sup> In the embryonic testis the germinal epi-

<sup>5</sup> Notable exceptions should be mentioned in the case of certain species such as the mole (Godet, 1950) and the desman or "water shrew" (Peyre, 1955) in which, as a normal condition, the ovarian medulla is so strongly developed as to resemble a testis, and so active physiologically as to produce strong masculinization of many parts of the genital tract. A somewhat similar development and hypertrophy of the medullary component also occurs in the fetal ovary of the horse (for the literature on this unusual condition see Cole, Hart, Lyons and Catchpole, 1933; Parkes, 1954).

thelium usually disappears early, and with its involution the potentiality for cortical development is permanently lost. On the other hand, *hermaphroditismus verus* not infrequently occurs as a developmental anomaly in many mammalian species (including man), indicating the existence of a basic bipotentiality. As an example, an extensive literature dealing with this subject in rodents has recently been summarized by Hollander, Gowen and Stadler (1956) and Kirkman (1958). Also it must be remembered that the classical example of an embryonic gonad transformed by the action of a sex hormone is found in the freemartin. In some

freemartin gonads morphologic transformation may be extreme, although the resulting testis-like structure is histologically abnormal and is almost invariably sterile (Wil-lier, 1921).<sup>9</sup>

## 2. *Bisexual Potentiality in the Embryonic Ovary of the Rat*

One of the best known cases illustrating a well marked capacity for bisexual differentiation in a mammalian gonad is provided by the embryonic ovary of the rat. The gonads of rat embryos have been isolated at various stages, both before and during the period of histologic differentiation, and transplanted to various locations in adult hosts of both sexes, normal and castrate, beneath the capsule of the kidney (Buyse, 1935; McIntyre, 1956), subcutaneously (Moore and Price, 1942), to the omentum (Holyoke, 1949) and into the anterior chamber of the eye (Torrey, 1950). In general, differentiation of the transplanted gonad proceeds without reference to the sex or the hormonal status of the host (certain minor exceptions will be noted later); however, there is a great difference in the behavior of testis and ovary after transplantation with respect to their capacity for autonomous differentiation. There is virtual agreement among all investigators that the testis primordium from the beginning of its development possesses a remarkably stable organization, and develops more or less normally in the various foreign environments, even when isolated before the beginning of histologic sex differentiation.<sup>10</sup> The case of the ovary is entirely different; its organization appears to be extremely labile and it is incapable of fully autonomous development until a relatively late stage of differentiation, after a well formed cortex is present. Before this stage (which according to Torrey is reached about the 17th day of development) ovaries in a high percentage of cases either do not develop at all, or are

prone to undergo spontaneous reversal, due apparently to incapacity of the prospective cortical component to develop effectively in abnormal tissue environments. On the other hand, the medullary component of the transplanted ovary suffers no such handicap and frequently assumes the lead in development. The embryonic ovary of the rat thus provides a flexible system for the study of the morphogenetic capabilities of the cortical and medullary components at different stages of development and under different experimental conditions.

When transplanted early in development prospective ovaries may give rise (Buyse, 1935) to structures of four types: (1) poorly developed grafts of indeterminate sex, (2) atypical ovaries of retarded development, (3) ovotestes in which both sex components are readily identifiable, and (4) rudimentary testes. As a group, ovaries are adversely affected by transplantation. Some fail entirely to develop the specific structure of gonads (type 1, above) and those that do give rise to ovaries that are greatly retarded (type 2). On the other hand, the medullary component of the prospective ovary resembles the testis in possessing considerable powers of self-differentiation. Thus in many cases the two components develop together, resulting in an ovotestis; in still others the cortical element fails completely to survive and the medulla alone develops, giving rise to a rudimentary testis. The development of types 3 and 4 is favored by the fact that cortical differentiation is almost always severely repressed. This may have the effect of releasing the medullary element from an inhibition normally imposed by the dominant cortex. In all cases, however, the phenomenon of reversal was found to be *unrelated to the sex of the host*; it seems to occur spontaneously, as it were, in consequence of a disturbance in the normal balance between cortical and medullary systems.

A similar behavior is seen when entire reproductive tracts of rat embryos, including the gonads, are transplanted subcutaneously into hosts of various ages, male or female, and into castrate hosts of both sexes (Moore and Price, 1942). Again it was found that the sex or the hormonal status of the host has no apparent influence on the results.

<sup>9</sup>For an important exception in which a freemartin testis is well supplied with germ cells and essentially normal in appearance see Hay (1950).

<sup>10</sup>Torrey considers that the self-differentiating capacity of the testis probably dates from the laying down of the early gonadal blastema, *i.e.*, the material of the primary sex cords, which occurs as early as the eleventh day of development.

Testes develop normally except that in castrate hosts there is some hypertrophy of the interstitial tissue, presumably in response to the gonadotrophin of the host (a phenomenon also reported by Jost, 1948b). Again many prospective ovaries give rise to gonads in which both cortex and medulla are well differentiated, the hypertrophied medullary cords sometimes approaching the structure of testis tubules. Cells resembling the interstitial cells of the testis are also found around these transformed medullary cords in grafts developing in castrate hosts. On the whole the ovarian cortex is better developed than in the experiments of Buyse, because perhaps the gonads were usually older and better differentiated at the time of transplantation.

Similar forms of development are found when embryonic gonads are transplanted to the omentum of adult hosts (Holyoke, 1949). Testes develop in a virtually normal manner regardless of the sex of the host; this author, however, describes certain effects which appear relatively late, after the testis has acquired its characteristic tubular structure. These are: (1) repression of tubule growth in some cases, with degenerative changes, a condition which was observed only in grafts growing in *female hosts*; (2) an increase in the amount of interstitium present, similar apparently to that reported by Moore and Price. Transplanted ovaries display the same variability as in the foregoing experiments; cortical development is adversely affected and sometimes fails altogether. In all cases in which cortical structure could be well identified there was also more or less hypertrophy of the medulla, sometimes to the point where the gonads were classified as ovotestes. This latter condition was reported only in *male hosts*, and this is perhaps the only change that might be interpreted as a reversal of sex conditioned by the sex of the host. On this point the findings differ from those of Buyse, of Moore and Price, and of Torrey, all of whom reported similar changes but without relation to the host's sex.

A further study of the problem was made by Torrey (1950). In his experiments the embryonic gonads were transplanted to the anterior chamber of the eye, using hosts of various ages and of both sexes. He con-

firmed the main conclusions of Buyse and of Moore and Price (Holyoke's study was not then available for consideration), namely, that regardless of the stage at which the primordium is isolated, testes are capable of an autonomous and virtually normal development, irrespective of the type of host in which they develop, whereas ovaries vary greatly in the state of differentiation attained, depending on the stage of development at which they are isolated.

Torrey paid particular attention to the importance of developmental age in the fate of grafted ovaries. When transplanted before the appearance of a definite cortical zone (zone of secondary sex cords), prospective ovaries show little capacity for development of cortex; on the contrary (as found by previous workers), there is a marked tendency to hypertrophy of the medullary component, leading in some cases to testis formation. This tendency is not influenced by the sex of the host; rather, it seems to be inherent in the state of organization of the primordium at the time of transplantation. In the young ovary the medullary component (primary sex cords) is already in existence; the cortex does not appear as a discrete tissue until much later, and only after a well defined cortex is present is the gonad capable of development as an ovary. The fate of the transplanted ovary appears, then, to be primarily a matter of the self-differentiating capacities of the elements already formed and present in the primordium at the time of its isolation. The development of these elements is influenced also by the temperature of the eye chamber, a point not directly involved in the present discussion.

In the foregoing experiments it has been emphasized that the hormonal environment provided by the host seems to have no important influence on the sexual differentiation of the transplanted gonads (for a partial exception as noted above see Holyoke). The question thus arises whether the hormones of *embryonic gonads* might be more effective. An answer to this question was sought by McIntyre (1956) who transplanted the embryonic testis and ovary together beneath the capsule of the kidney of adult castrate hosts of both sexes. The gonads were placed in close contact in order

to determine whether hormones or other diffusible substances might be produced, capable of modifying the differentiation process. As a control procedure, ovaries were transplanted alone, or in association with nongonadal tissues, into noncastrate male hosts.

The results in most respects correspond with those already described. The testis was found to develop normally regardless of the sex of the host or the presence of a contiguous ovary. The behavior of grafted ovaries differed, however, according to whether they were associated with an embryonic testis, or developed alone or with other tissues (control operations). In the first case the ovaries were strongly modified along the lines previously described. Some differentiated poorly or hardly at all, others showed fairly good development of the cortex with some primary follicles, but in the medullary area tubular structures resembling testis tubules were found. Still others had a few well formed follicles in the cortex, but again tubular structures were present in the medulla which sometimes contained oocytes. The two last mentioned categories would seem to correspond to the "ovotestes," or ovaries with "transformed medullary cords" described by previous writers. In contrast, however, ovaries grafted alone, or with nongonadal tissues, were found to differentiate in an almost normal fashion. It is at this point that the findings depart from those of other investigators. The conclusion was reached that the modifications observed in ovaries associated with embryonic testes are due to a substance produced by the testis, and considered to be of the nature of a medullary inductor.

However, both with respect to the severity of cortical inhibition and the degree of masculinization of medullary structures, these modified ovaries do not appear to differ significantly from those described by previous investigators when ovaries were grafted alone. The significance of the results rests then upon failure to obtain similar changes in the control ovaries. The age and state of differentiation of the control gonads at the time of transplantation is important. They were from donor fetuses of 15 days development, and although older than any used by Buyse they were still within the

period during which Torrey found the ovary to be extremely labile in its differentiation. According to Torrey only a small proportion of ovaries aged 15 to 16 days developed as such (5 of 17 cases) whereas at an age of 17 days—after the cortical zone is established—ovaries are obtained almost without exception (10 of 11 cases). Further experiments are needed to clarify this matter.

In all of the foregoing experiments there was general agreement (for a partial exception see Holyoke) that the hormonal environment provided by adult hosts of both sexes, intact or castrate, has no important influence on the sexual differentiation of the transplanted gonads, even in the case of ovaries which are still in a labile state. The reason for this is not clear. Possibly it is a matter of insufficient concentration of the host hormone (compare the case of the chick, p. 99), or it may be that after transplantation a certain interval, perhaps a critical one, elapses before vascularization makes the graft accessible to the hormones of the host. On the other hand, it has been pointed out that in the embryos of *placental mammals* pure hormones thus far have produced no significant changes in the differentiation of the gonads. The question remains whether there is an essential difference between the sex hormones of adults and the hormones or sex-differentiating substances elaborated by embryonic gonads.

### 3. Experimental Transformation of the Testis in the Opossum

Up to now the clearest experimental demonstration of sex reversal in the gonad of any mammal, and the only one to be produced by a steroid hormone, has been obtained in the gonads of young opossums (*Didelphis virginiana*). In this species the embryonic testes, if taken in time, are readily transformed into ovotestes or even into "ovaries" of remarkably normal histologic structure by the action of estradiol dipropionate (Burns, 1950, 1955a, 1956b). The hormone is administered at short intervals, beginning at a stage of development corresponding to stage B in Figure 2.16. This is the condition found at birth in litters born at stage 34 of McCrady's series (McCrady, 1938). It is characterized by the presence of well developed primary sex cords which

are just in process of separation from the overlying germinal epithelium. The germinal epithelium, however, is still present as a layer of low, columnar cells and at this stage represents, potentially, the female component of the young testis. Normally the germinal epithelium does not survive long after birth. In the course of the first day of post-natal life irreversible changes occur which lead to its rapid involution. It is the presence at stage 34 of a viable germinal epithelium which makes possible the subsequent conversion of the testis into an ovary, since it is this layer which must produce the cortical zone of the transformed gonad by the proliferation of secondary sex cords. In so doing it plays precisely the same role as the corresponding layer in the development of the ovary.

Treatment with estradiol dipropionate has been carried out over varying periods up to an age of 30 days postpartum or somewhat longer, after which survival becomes difficult (Burns, 1939b). At the present time 46 male fetuses have been studied histologi-

cally, comprising all the surviving males of 13 litters. Without exception, every specimen shows histologic modifications of the type described below, the stage of transformation attained varying only with the length of treatment. The process of transformation consists at first of a gradual inhibition and suppression of testicular differentiation, accompanied by *persistence of the germinal epithelium*. At the same time the differentiation of the interstitial tissue is severely repressed (compare A and B, Fig. 2.17). Atrophy of the interstitial tissue has also been described by Raynaud (1950) in the testes of mouse embryos treated with estrogen. After an interval (which varies in different experimental litters and is apparently influenced by dosage) the germinal epithelium again becomes active, producing secondary sex cords which form a cortical zone of varying thickness depending on the length of treatment (Fig. 2.18).

The first essential in obtaining transformation of the testis is the timing of the first treatment, *which must not be later than*

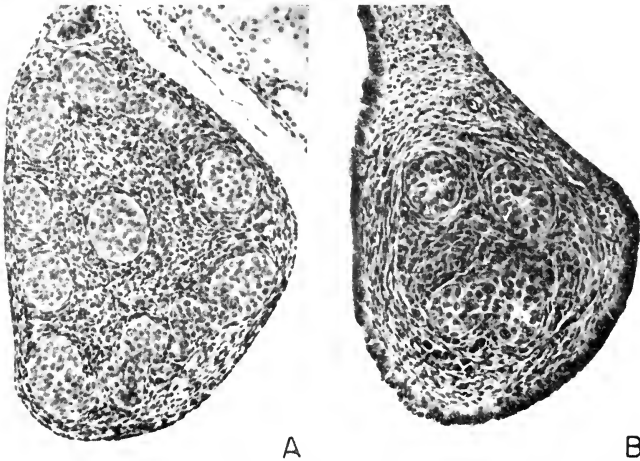

FIG. 2.17. The effects of female hormone on differentiation of the testis in young opossums. A. Normal testis about 10 days after birth. Note the thin, serous character of the epithelium covering the testis (originally the germinal epithelium), the presence of a distinct tunica albuginea, the prominent testis cords (prospective tubules), and the richly developed interstitium. B. Testis (at somewhat higher magnification) of a young male aged 14 days, modified by the action of the female hormone estradiol dipropionate. Note the greatly reduced condition of the testis cords and interstitial tissue, the thick, spongy character of the tunica albuginea, and especially the survival of the germinal epithelium long after the stage at which it normally undergoes involution.

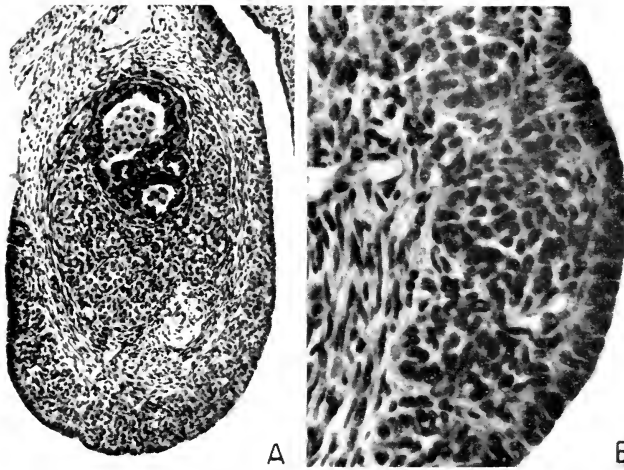

FIG. 218. A. Testis of an opossum aged 50 days, converted into an ovotestis by the action of estradiol dipropionate. Internally the reduced and disorganized medullary region is seen, separated from the external cortical zone by the well defined, fibrous tunica layer. The large, irregular cavity in the upper center, lined by a heavy epithelium, is the rete testis. B. Detail at higher power of the cortex, showing the structure of the cortical cords (which are sterile) and the highly developed germinal epithelium.

stage 34 if the germinal epithelium is to be preserved. In earlier experiments, in which treatment was begun after stage 35, there were no significant effects on the differentiation of the gonads, even in cases where almost complete transformation of the accessory sex structures had occurred. It is now evident that in these experiments the first application of the hormone came too late to prevent involution of the germinal epithelium, thus precluding development of a cortex. Also of importance is the dosage, which must be kept at a low level to secure a good result. This point is crucial for the survival of germ cells in the developing cortex. High dosages always result in *complete sterility* of the cortical zone, even when this layer is otherwise well developed (Fig. 2.18). With lower doses, however, germ cells are found in limited numbers in the cortex, sometimes sparsely scattered, sometimes in small groups, and not infrequently these cells display the cytologic characters of young oocytes (Fig. 2.20). Often there is a considerable growth of the cytoplasm and well formed primordial follicles are seen (Fig. 2.20B).

Treatment with relatively low doses of estradiol (of the order of 0.2 to 0.3  $\mu\text{g}$ . per day) from birth to an age of 20 days produces a remarkable transformation of the testis, which retains hardly any normal features (Burns, 1956b). Rather, it presents the appearance of a somewhat atypical ovary (Fig. 2.19B). The only remnant of testicular structure is a small, central nodule at the junction of the rete canals, and the massive cortical zone is covered externally by a thick germinal epithelium. The cortex of the transformed testis contains germ cells in considerable numbers, including a few large oocytes. Views of cortical areas in gonads of this group are shown in Figure 2.20A and B. In more recent experiments, using still lower doses and a longer period of treatment (thus far the longest experiment has extended to an age of 33 days postpartum), the result is even more striking, the structure of the cortex in many cases approximating that of normal ovaries. Always, however, certain remnants of testicular structure persist in the medullary region (Fig. 2.21, compare A and B). The number of oocytes in the cortex is enormous.

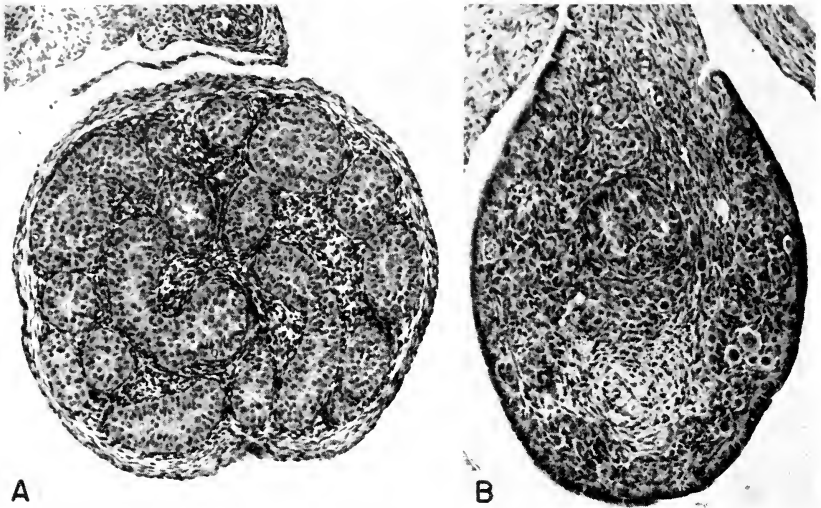

FIG. 2.19. A. The testis of a normal male opossum aged 20 days for comparison with that of another male, B, treated for 20 days with a low dosage of estradiol dipropionate as described in the text. Only a remnant of testis structure survives as a nodular mass in the medullary region, representing straight tubules at the point of junction with the rete canals. Note the well developed cortical zone with numerous germ cells and a heavy germinal epithelium.

greater than in the preceding experiment. It is not clear whether this is due mainly to the lowered dosage or to what extent it is a result of multiplication of ovogonia present in smaller numbers in the younger gonads (see Fig. 2.19B). In any case, dosage in some manner influences the survival and multiplication of the gonia. Although the cortex of the transformed testis is always well developed, there is great variability in the extent to which testicular structures have survived in the medullary zone. Some gonads exhibit well preserved male sex cords and present the picture of a typical ovotestis, whereas in others (Fig. 2.21B) only traces of the male elements remain in the form of degenerate sex cords and patches of fibrous tissue. In these cases transformation is all but complete.

Since this work is still in progress interpretation must be tentative. It seems that the primary effect of the female hormone is a strong inhibition of the testis, affecting both the primary sex cords and the interstitium. Both influences are apparent at an early stage (Fig. 2.17). Inhibition of testicu-

lar differentiation presumably permits survival of the germinal epithelium, to be followed later by a renewal of activity producing secondary sex cords and the cortex. This course of events may simply be the result of release from an inhibition normally imposed by the differentiating testis. Counterparts are seen, for example, in the spontaneous development of the medullary component in transplanted rat ovaries when cortical differentiation is interfered with, in the development of the rudimentary cortex in *Pleurodeles* after the medulla has been suppressed by testosterone (p. 94), or in the development of the heterotypic sex component after castration in the toad or the newly hatched chick. In the light of current knowledge regarding the secretory capacity of the embryonic testis (for discussions see Jost, 1953, 1957; Burns, 1955b, and later in this chapter) it is probable that the primary condition for survival of the germinal epithelium is suppression of the interstitial tissue; cortical differentiation is presumably the consequence of escape from an inhibition normally exerted



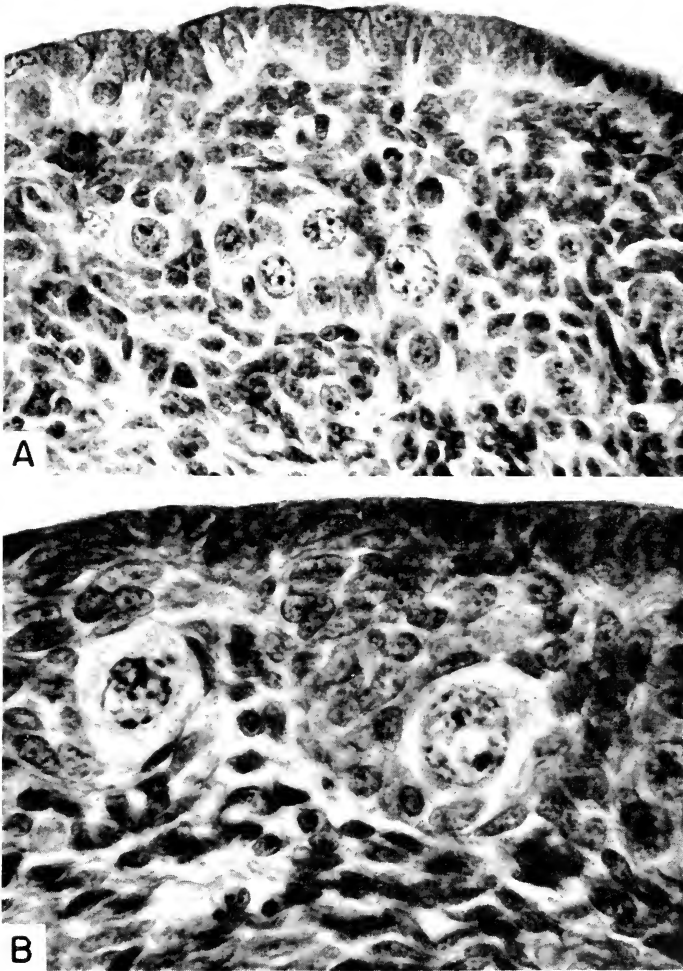

FIG. 2.20. *A.* View at higher magnification ( $\times 1000$ ) of the cortex of a transformed testis containing gonial, and other germ cells showing the early meiotic prophase stages of young oocytes. *B.* Cortex of another transformed testis of the same experimental group showing the formation of primordial follicles ( $\times 1000$ ).

by the testis hormone. For this there is no direct evidence; however, in typical ovaries, with a well developed cortex, the tubular elements may also at times be very well preserved but the interstitium is degenerate. This interpretation does not require positive stimulation by the female

hormone to promote cortical differentiation, but it does not exclude the possibility that this may occur. The germinal epithelium of transformed testes is strongly hypertrophied in comparison with that of normal ovaries of the same age (Figs. 2.18*B*, 2.19*B*, and 20); a condition which is seen also in the ovaries

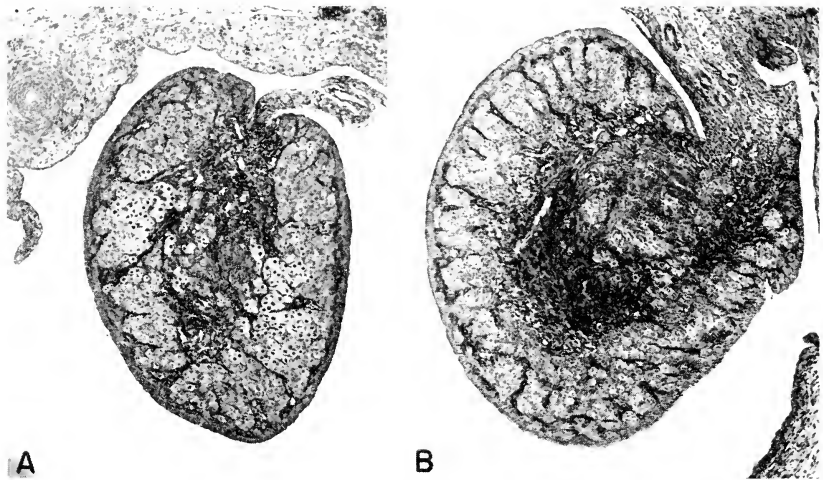

FIG. 221. A. The normal ovary of a young female aged 30 days; note the highly developed cortex and the absence of conspicuous structures in the medullary area. B. Transformed testis of a young male treated with estradiol dipropionate for a period of 33 days; for details see text. Observe the remarkable development of the cortex associated, however, with distinct remains of testicular structure in the medulla.

of females receiving estradiol. Also, precocious growth of a certain number of follicles commonly occurs in the cortex of transformed testes (Figs. 2.19B and 2.20). This effect, however, may be exerted indirectly in response to gonadotrophic stimulation.

It should be noted that in the only other case of an embryonic mammalian gonad transformed by hormone action, that of the freemartin, the reversal involves the conversion of ovary to testis. In the opossum the situation is reversed. In those cases of complete, or near complete, transformation in amphibians, in which the sex chromosome complex has been determined, it appears that it is always the homogametic sex that is readily transformed (Gallien, 1955). This generalization would seem to apply also in birds and in the case of the freemartin. The opossum, however, is certainly an exception; the male in this species is heterogametic (Painter, 1922; Tijo and Puek, 1958; Graham, 1956). In certain fishes at least sex genotype is apparently of no consequence since functional sex reversal proceeds equally well in either direction (Yamamoto, 1953, 1958).

#### V. The Role of Hormones in the Development of the Accessory Sex Structures

The heterogeneous character of the various structures comprising the genital complex of the embryo has been previously emphasized as providing a basis for great variability in their behavior under experimental conditions. On the basis of embryonic origin and morphologic relationships the accessory sex structures fall into three principal groups: (1) the embryonic sex ducts and related structures which are taken over from the primitive nephric system; (2) derivatives of the cloaca or the urinogenital sinus, derived at an early stage from the primitive gut; and (3) external organs of sex. Because of the great diversity of the so-called *secondary sex characters* in vertebrates, and because as a rule they become sexually differentiated only in postpubertal life, these structures can be considered only in special cases.

Two distinct stages can be recognized in the development of the accessory sex structures: an early phase which is independent of sex, and which follows a virtually identi-

cal course in all individuals, and a later phase, the period of sexual differentiation, which is chiefly hormone conditioned. During the first phase the primordial structures necessary for the development of both sexes are laid down and develop in similar or identical fashion up to a certain point, at which stage each embryo possesses, morphologically and for a certain time, the capacity to develop into an individual of either sex (Fig. 2.22A). In this early, indifferent phase of development the sex primordia show little reactivity to hormones, capacity for response evidently requiring a certain degree of maturation in the reacting organs or tissues. The onset of sexual differentiation of the accessory structures follows the appearance of sexual differentiation in the gonads.

and this is the phase of development in which control by hormones is predicated.

#### A. DIFFERENTIATION OF THE EMBRYONIC GONADUCTS

A complete account of the origin and normal development of the embryonic sex ducts has been given by Willier (1939) and Burns (1955b). In the embryos of most vertebrates both sex ducts are present and equally developed throughout the sexually undifferentiated period. In many amphibians this primitive condition is retained throughout larval life or indefinitely; the male, or *Wolffian ducts*, function as nephric ducts in both sexes and in females they are permanently retained in this capacity. The *Müllerian ducts* persist throughout life in the males of

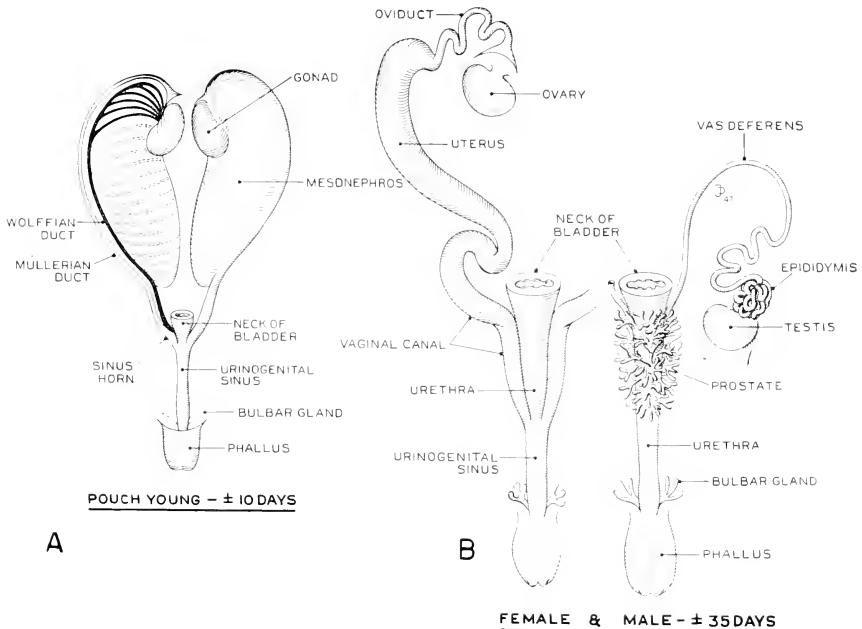

FIG. 2.22. Early development and sexual differentiation in the genital tracts of young opossums. A. The bisexual stage of development in a female embryo  $\pm 10$  days of age, showing the paired gonaducts of both sexes, the sexually indifferent stage of the urinogenital sinus, and the undifferentiated genital tubercle or phallus. B. Male and female at about 35 days, when sexual differentiation is far advanced, showing the structures which develop from the primitive sex ducts, and dimorphic development of the sinus region. The phallus shows chiefly a difference in size, without marked morphologic divergence. (From R. K. Burns, *Survey Biol. Progr.*, **1**, 233-266, 1949.)

many species as complete if somewhat rudimentary canals. In amniote embryos, on the other hand, the ducts of the genetically recessive sex are typically transient structures. Sexual differentiation consists in the retention of one sex duct with development of its derivative structures, whereas the other either disappears completely or survives only in a more or less vestigial condition (Fig. 2.22*B*). Under these circumstances experimental reversal of sex, to be successful, must be properly timed with respect to the state of development of the heterotypic duct. Once regression has been determined it is impossible to preserve the duct.

### 1. The Müllerian Ducts: the Effects of Female Hormones

The effects of female hormones, whether produced by grafted ovarian tissue or administered in pure form, may be stated generally as follows: in female subjects as a rule they accelerate sexual differentiation, inducing a precocious hypertrophy of the Müllerian ducts which with large doses may become extreme. In males female hormones cause persistence of the Müllerian ducts followed by differentiation in varying degrees depending on timing of treatment, dosage, and the special status of the duct in the species under consideration. There are many deviations from this pattern, however, arising in part from basic group or species differences and in part from the many experimental variables.<sup>11</sup>

In most amphibians the Müllerian ducts of both sexes respond readily to sex hormones during larval life. In *Triturus* (*Triton*), after castration, both sex ducts remain indefinitely in a more or less undifferentiated condition, thus providing an ideal basis for sex reversal. Grafting gonads into castrates of either sex readily induces differentiation of the appropriate duct (de Beaumont, 1933). Furthermore, in the males of various species which have undergone complete sex reversal the later development of

the Müllerian ducts is always in accordance with the altered sex of the gonad, and the ducts may eventually become completely functional (see *e.g.*, Humphrey, 1942; Ponce, 1949; Gallien, 1955). The reaction of the Müllerian ducts to female hormones (estradiol, estrone) varies in different species and is greatly influenced by the stage at which treatment occurs and by dosage as well. In *Ambystoma* the ducts show a marked hypertrophy in females and the response in males is almost as great. The backward growth of the incomplete ducts is also accelerated (Burns, 1938a; Foote, 1941). Large doses, paradoxically, may arrest the backward extension of the duct (as do male hormones, *q.v.*) but the part already laid down becomes greatly hypertrophied (for a summary see Gallien, 1955).

The effects of the female hormone in bird embryos are particularly striking (Wolff, 1938, 1950; Willier, 1939; Gaarenstroom, 1939; Stoll, 1948). In male embryos both oviducts persist and hypertrophy as does also the right duct of the female, which normally undergoes involution (Figs. 2.23 and 2.12). Once established these effects are permanent, development continuing even after hatching (Wolff, 1938). However, the period of susceptibility to the hormone is limited. Retention and permanent development can be assured only by treatment up to the seventh day of incubation (this is the so-called "stabilization effect" of Wolff); later treatment is without effect for the preservation of the ducts, irreversible changes having occurred which determine their regression with finality (Wolff, 1953b). The hormone of the embryonic ovary has the same effects. Ovaries grafted into the body cavity of male embryos cause persistence and development of the oviducts (Wolff, 1946). The effect of the hormone appears to be a direct one since it occurs independently of any effect on the gonads.

In mammalian embryos the effects are in general similar, but marked species differences have been found. Female hormones cause accelerated development of the Müllerian duct derivatives in females, and with high dosages oviducts, uteri, and vaginal canals all show great hypertrophy. In male embryos the ducts are frequently retained and also differentiate regionally into ovi-

<sup>11</sup> For reviews and references to a large literature covering amphibians, birds, and mammals see Humphrey, 1942; Wolff, 1938; Willier, 1939; Raymond, 1942; Greene, 1942; Moore, 1947; Jost, 1947a, 1948a, 1955; Ponce, 1949; Burns, 1949, 1955b; Stoll, 1950.

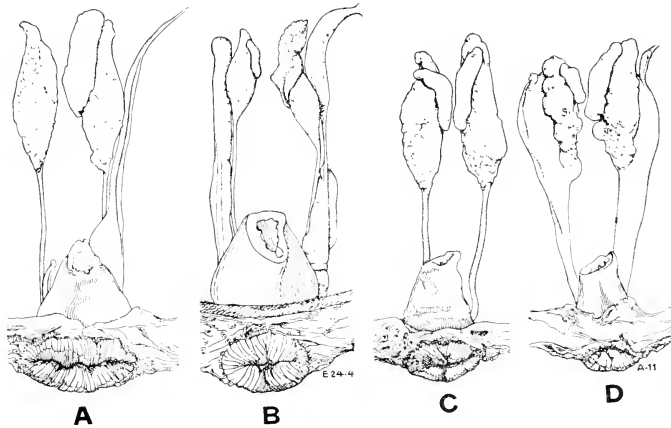

FIG. 2.23. The effects of sex hormones on development of the sex ducts in chick embryos. A. Normal female embryo of 18 days, showing development of the left oviduct with shell gland, and retrogression of the right. B. Genetic male embryo, 18 days, treated with 2.0 mg. estrone. Both oviducts are present and greatly hypertrophied. Compare with C for the normal condition. C. Normal male embryo at 17 days of incubation. Note the paired Wolffian ducts and absence of both oviducts. D. Genetic female embryo at 17 days, after treatment with 1.0 mg. androsterone, showing absence of both oviducts and extreme hypertrophy of the Wolffian ducts. For the normal female anatomy compare with A, and for normal size of male ducts see C. (From B. H. Willier, in *Sex and Internal Secretions*, 2nd ed., The Williams & Wilkins Co., 1939.)

duct, uterine tube, and vaginal canal (Greene, 1942; Burns, 1939b, 1942a and b; Moore, 1941; Raynaud, 1942; Jost, 1947a). Details of structure depend on the state of development of the rudimentary Müllerian ducts in the males of the species in question. The vagina may be defective or absent entirely in males of certain species, as in the opossum, in which the duct is usually incomplete, without a connection to the urogenital sinus. In other species the effects are slight or lacking entirely (Raynaud, 1950, the field mouse; White, 1949, the hamster; Davis and Potter, 1948, man).

*The effects of male hormones.* The effects of male hormones on the Müllerian ducts are more variable; strong inhibitory effects are obtained in many species and under proper experimental conditions; but with large doses stimulating or "paradoxical effects" often appear, such as have been described in the case of the gonads. The time of administration of the hormone is important. Both in chick embryos and in larval amphibians treatment with androgens before the appearance of the duct, or during

the formative period, may result in total suppression.<sup>12</sup> In amphibians, in which the Müllerian duct develops slowly, a particularly interesting situation is found. Early administration of testosterone propionate prevents development entirely (Burns, 1939c; Foote, 1941, *Ambystoma*) or may leave only the ostial rudiment (Gallien, 1955, *Pleurodeles*); however, treatment during the period of formation may result in suppression of the unformed portion of the duct, while the part already laid down persists and with large doses may even be strongly hypertrophied (Mintz, 1947). Here is a striking paradox in which different regions of the same structure (which are, however, developmentally of different age)

<sup>12</sup> See, for example, for amphibians, Burns, 1939c; Foote, 1941; Hamaoka, 1941b; for the chick, Willier, 1939; Wolff, 1938, 1950; Gaarenstroom, 1939; Stoll, 1948; Huijbers, 1951. Exceptions must be noted, however, in a few cases: the field mouse (Raynaud, 1950); the hamster (Bruner and Witschi, 1946; White, 1949); man (Davis and Potter, 1948) in which no clear effects were observed, whether because of true species differences or of experimental variables is not clear.

react in an opposite way to the same treatment.

In chick embryos also, early treatment with male hormone may completely suppress development of the Müllerian ducts (Figs. 2.23 and 2.12; see also Gaarenstroom, 1939; Stoll, 1948, 1950) and a similar effect is produced by grafts of the embryonic testis (Wolff, 1946; Huijbers, 1951). Again, however, suppression of the ducts depends on certain rather precise conditions, the dose must be adequate and the hormone must act at the proper stage of development. They can be suppressed completely before the 6th or 7th day of development (Stoll, 1948; Huijbers, 1951) but later treatment is ineffective. Thus (as was found also for the "stabilizing effect" of female hormone on the Müllerian ducts of male embryos) there is a limited period of development during which the ducts are susceptible to inhibition by male hormones. In contrast with these clear-cut results, however, a paradoxical hypertrophic effect of certain male hormones (androsterone, dehydro-androsterone and related compounds) has been reported on the Müllerian ducts of chick embryos after rather large doses (Willier, 1939; Wolff, 1938; Wolff, Strudel and Wolff, 1948).

In the embryos of mammals effective inhibition of the Müllerian ducts by male hormones has not been found, but suppression of regional parts of the duct sometimes occurs. The ostial portion is suppressed in the hedge-hog (Mombaerts, 1944) and the vaginal segment (the last part to be laid down) is frequently inhibited in female opossums (Burns, 1942a, b) and in mice (Raynaud, 1942). In the mouse and in the rabbit failure of the posterior ends of the ducts to unite to form vagina and *corpus uteri* has been reported (Raynaud, 1942; Jost, 1947a). In female opossum embryos treated with testosterone propionate the vaginal canals are absent in about half of all cases and are always absent in males (in which, as noted earlier, the terminal portion of the Müllerian duct is lacking). However, a paradoxical stimulation of the Müllerian duct and its derivatives also takes place in opossums of both sexes when large doses (25 to 100  $\mu\text{g}$ . per day) are employed (Fig. 2.24; see also Moore, 1941, 1947; Burns, 1939a, 1955b) an effect which completely disap-

pears when the dose is lowered to  $\pm 5 \mu\text{g}$ . or less (Burns, 1942a, b).

In contrast with the failure of androgenic hormones to inhibit effectively the Müllerian ducts of mammalian embryos it is known that they are normally inhibited by the hormone of the fetal testis. In castrated male fetuses of the rabbit the ducts persist instead of regressing and develop almost as well as in normal females; conversely, the embryonic testis when grafted into a female fetus inhibits the Müllerian duct in the vicinity of the graft (Jost, 1953, 1955). On the other hand, a crystal of testosterone propionate implanted in the same manner lacks this inhibiting power. Testosterone also fails to inhibit development of the Müllerian ducts in castrate males although in all other respects it fully compensates for the absence of the testis (Jost, 1947b, 1953, 1955). This discrepancy has led to the suggestion (Jost) that in mammals another substance may be required for the inhibition of the Müllerian ducts. In the fetal rat, on the other hand (Price, 1956), neither testosterone nor the presence of the *fetal testis* influences the differentiation of the Müllerian ducts in genital tracts when isolated at an age of 17.5 days and cultured *in vitro*. In this case, however (as suggested by Price), it is likely that development of the Müllerian ducts has already been irreversibly determined before the time of explantation. This question will come up again in a discussion of the stage at which irreversible determination occurs in the rat.

*The effects of castration on development of the Müllerian ducts.* Although the effects of steroid hormones on the development of the Müllerian ducts are on the whole consistent with theory (failure of the ducts of *mammalian embryos* to be inhibited by male hormone is a notable exception) such results do not constitute evidence that sex hormones are present and active in the normal differentiation of sex. A direct test of this question is provided by castration of the embryo. The effects of castration in *amphibian larvae* have been previously mentioned (p. 112): after removal of the gonads both sex ducts fail to differentiate further, persisting indefinitely in the condition in which they were at operation. In recent years this difficult operation has been

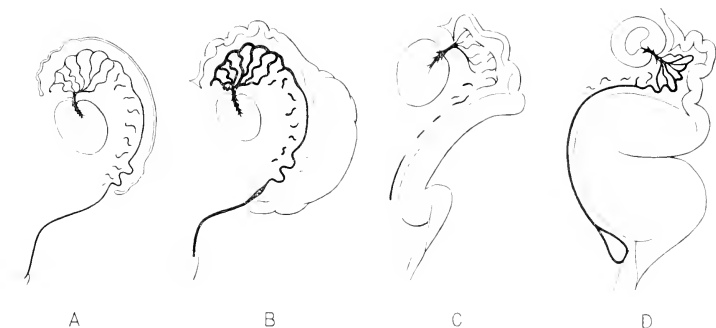

FIG. 2.24. Diagrammatic representation of the effects of relatively large doses of testosterone propionate, administered from birth to an age of 50 days, on the development of the sex ducts in young opossums. *A*, Sex ducts as they appear in a normal male at 50 days; the vas deferens (Wolffian duct), epididymal tubules and remnants of mesonephric tubules are shown in black; the atrophic Müllerian duct is unshaded and the testis stippled. *B*, The effects of the male hormone on the male duct system appear throughout; however, large dosages also induce a paradoxical growth and development of the uterine and tubal regions of the Müllerian duct, but the vaginal segment is absent as in the normal male. *C*, The sex ducts as they appear in a normal female at 50 days—breakdown and disappearance of the Wolffian duct and associated structures, regional development of the Müllerian duct into tubal, uterine, and vaginal segments. The contribution of the urogenital sinus to the vaginal canal is indicated in stipple. *D*, The effects of the male hormone in a female subject; note the preservation and great hypertrophy of the male duct system which is not, however, as large or as well differentiated as in the treated male; note also the striking paradoxical effect of a large dosage of androgen on the female genital tract which, at the same dosage level, is far greater than in the treated male (*B*). These paradoxical effects of androgen on the Müllerian duct derivatives disappear entirely at lower dosages.

carried out in a number of species of birds and mammals.<sup>13</sup>

Early castration of avian embryos is followed by persistence and development of Müllerian ducts in both sexes (the chick and the duck, Wolff and Wolff, 1951; Huijbers, 1951). After total castration in males both ducts persist and develop, but partial castration results in regression as usual. In females, in which the right duct normally regresses, both ducts persist and are well developed.<sup>14</sup> Thus, in the absence of the gonads the Müllerian ducts follow the same pattern of development regardless of sex (Fig. 2.25). It is clear that the testes are

<sup>13</sup> In the rabbit (Jost, 1947b); the mouse (Raynaud and Frilley, 1947) and the rat (Wells, 1946, 1950); in the chick and the duck embryo (Wolff, 1950; Wolff and Wolff, 1951; and Huijbers, 1951).

<sup>14</sup> In birds involution of the *right* Müllerian duct of the female is normally conditioned in some manner by the ovaries, and it has been shown further that the presence of either ovary is sufficient (Wolff and Wolff, 1951). The exact nature of the inhibitory factor in this interesting case is not known.

necessary for normal inhibition of the ducts in male embryos, and it was pointed out earlier that a graft of the embryonic testis has the same effect in females (Wolff, 1946). The ovaries, on the contrary, have no positive role in the development of the Müllerian ducts, but actually inhibit the right duct; in their absence both ducts develop without hormonal conditioning.

Among mammalian embryos the case of the rabbit is best known (Jost, 1947b). Castration of the female again has no important consequences; the Müllerian ducts continue to develop and shortly before birth are only slightly smaller than in normal females. In male castrates, on the other hand, the situation is very different; if the operation is performed early enough the Müllerian ducts, instead of regressing, persist and develop, becoming practically indistinguishable from those of castrate females (Table 2.2, Fig. 2.26). Thus, as in birds, castrates of either sex follow identical patterns of development.

Nevertheless, if castration is delayed be-

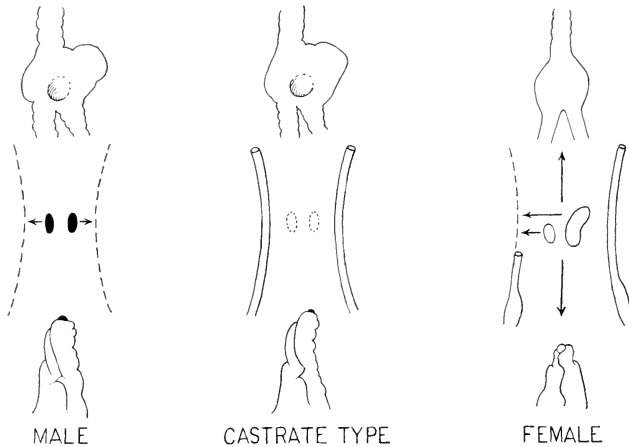

FIG. 2.25. Diagrams summarizing the effects of castration on the development of the syrinx (top row) oviducts, and genital tubercle (below) in bird embryos (chick and duck). The left column shows the normal condition in the male; note the complete retrogression of the Müllerian ducts (broken lines) under the influence of the embryonic testes (black). In the right column, the normal female condition showing the retrogression of the right oviduct. The arrows indicate the inhibitory action normally exerted by the ovaries on the syrinx, right oviduct and genital tubercle. The *castrate type*, which appears regardless of genetic sex, is seen in the center. In castrates both oviducts persist in complete form and are as well developed as the normal left oviduct; the syrinx and genital tubercle, however, assume the male form in the absence of the inhibition exerted by the ovaries. Note the extreme asymmetry of the male syrinx and tubercle, as compared with the primitive symmetrical form retained in the normal female. (After Et. Wolff and Em. Wolff, *J. Exper. Zool.*, **116**, 59-97, 1951.)

TABLE 22

*Effects of castration in male rabbit fetuses studied at the age of 28 days*  
(After A. Jost, *Recent Progr. Hormone Res.*, **8**, 379-418, 1953.)

AGE AT CASTRATION	MÜLLERIAN DUCTS	WOLFFIAN DUCTS AND DERIVATIVES	PROSTATIC GLANDS	EXTERNAL GENITALIA
19 DAYS (2 cases)	PERSISTENT	ABSENT	ABSENT	FEMALE
20-21 DAYS (11 cases)	PERSISTENT	CAUDAL REMNANTS (in 3 cases)	VENTRAL BUDS PRESENT	FEMALE
22-23 DAYS (6 cases)	UTERO-VAGINAL SEGMENTS PERSISTENT	CAUDAL REMNANTS	DEVELOPMENT VARIABLE	HYPOSPADIC
23 DAYS (4 cases)	ABSENT (=NORMAL)	ABSENT- SMALL SEMINAL VESICLES PRESENT	WELL DEVELOPED	NORMAL
24 DAYS (3 cases)	ABSENT (=NORMAL)	NORMAL	WELL DEVELOPED	NORMAL

- 1 *Unilateral castration is followed by normal development.*
- 2 *Castration effects are prevented by Testosterone propionate given at operation*

yond a certain stage (about the 22nd day of gestation in the rabbit; Jost, 1947b), c) the ducts subsequently undergo involution as usual (Table 2.2). Evidently there is a

rather limited period during which involution of the oviducts is determined, as was shown also for the chick in the case of male hormones administered experimentally.



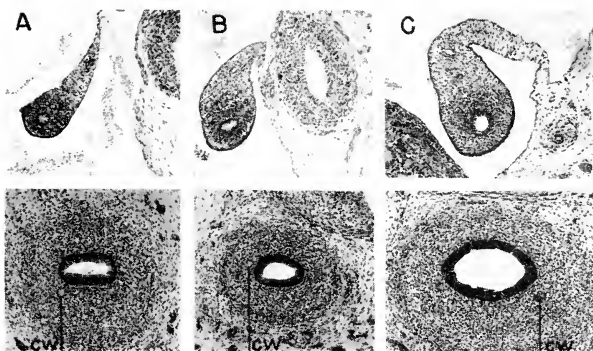

FIG. 226. The effects of castration on the development of the sex ducts in the rabbit. *A*. Persistence of the Müllerian duct (uterine level) above, and the vaginal canal, below, in a castrate male. *B*. The same structures seen in a castrate female as compared with the condition in the normal female shown in *C*. Note almost complete involution of the male duct except for remnants (CW) in the castrate male, and compare with the castrate and the normal female. Castration of the female (*B*) has little effect on the pattern of development which follows; on the other hand, castration of the male results in involution of the Wolffian duct and development of the Müllerian duct, a reversal of the normal pattern. (From A. Jost, *Arch. Anat. microscop. et Morphol. expér.*, **36**, 271-315, 1947.)

Once conditioning has occurred the effect is irreversible.

In view of the decisive role of the embryonic testis in the development of the Müllerian ducts, as shown by castration experiments, it is significant to note the condition of the genital tracts in certain "lateral gynandromorphs" of genetic origin in mice (Hollander, Gowen and Stadler, 1956) which have an ovary on one side of the body and a testis on the other. Both gonads are usually small and hypoplastic. Without exception, however, on the side of the testis the Müllerian duct derivatives are absent entirely and the male duct system is developed. Contralaterally, a female genital tract is always found although it shows great variation in size. An almost identical condition has recently been described in a gynandromorphic hamster (Kirkman, 1958). The manner in which the influence of the testis tends to be limited to its own side of the body in these cases is of special interest, and will be considered later in dealing with the localized character of hormone effects. It is undoubtedly related to the early stage at which the testis begins to exert its effect and probably also to its reduced size in nearly all cases.

#### *The development of the Müllerian ducts*

*after isolation in vitro.* At this point, in the case of mammalian embryos, an obvious question presents itself. Is development of Müllerian ducts in male castrates in fact a purely autonomous process, due to release from an inhibition normally exerted by the testes or, in the absence of the gonads, does some other humoral factor intervene to assure their development? It is known that in various species of mammals estrogens are present in the placenta and fetal fluids in considerable amounts (for references see Price, 1947; Parkes, 1954), and the possibility arises that development of the ducts after castration may be maintained under the influence of an estrogenic substance of nongonadal or of maternal origin. This question has been answered, in the negative, by experiments designed to test the self-differentiating capacity of the ducts under conditions of physiologic isolation. When explanted *in vitro* (with pieces of the associated mesonephric bodies) the Müllerian ducts of rat embryos, regardless of the sex of the donor embryo, survive and continue their development in the same manner as in castrate fetuses (Jost and Bergerard, 1949; Jost and Bozic, 1951). In these experiments the ducts were isolated at ages of 15 to 16 days, and 16 to 17 days re-

spectively. Similar behavior is seen in grafts to the eye chamber of castrate hosts (the guinea pig, Bronski, 1950) and after transplantation of the entire embryonic genital tract into castrate and noncastrate hosts of various ages (the rat, Moore and Price, 1942). Although the experimental environments in all of these cases cannot be considered hormone-free in the strict sense (Jost and Bozic, 1951), the results indicate that the development of the female sex ducts when removed from the influence of the embryonic testis is a matter of autonomous differentiation.

The above experiments show that in rat embryos the fate of the Müllerian ducts is undetermined up to an age of 16 to 17 days at least (Jost and Bozic), since at this age these ducts in male embryos still retain their capacity for autonomous development when removed from the inhibiting influence of the testis. Experiments on the same species (Price, 1956; Price and Pannabecker, 1956) indicate that involution is irreversibly determined at about the age of 17 days. The genital tracts of *male fetuses* were removed at 17.5 days of gestation and cultured *in vitro*. At this stage the first signs of involution can be detected in the region of the ostium but the posterior extremities of the ducts are still growing. After explantation the ducts continue to regress regardless of whether the testes are included in the explant or not, whereas those of female fetuses under the same conditions develop normally. It seems that the fate of the Müllerian ducts in the male becomes irreversibly fixed within the brief period of a day by exposure to the testis hormone.

This question has been investigated in some detail in the chick. It had been shown earlier that after transplantation to the chorioallantois, Müllerian ducts from embryos of *either sex* differentiate completely if isolated before the beginning of sex differentiation. But if transplanted later than the 10th day of incubation the ducts of male embryos invariably degenerate; beyond this age their involution has been finally determined (Wolff and Ostertag, 1949). Making use of the technique of culture *in vitro* the analysis has been carried farther (Wolff and Lutz-Ostertag, 1952). When isolated

before the appearance of sex differentiation in the gonads, again the Müllerian ducts of both sexes undergo a complete differentiation, as in castrate embryos; but if isolated after the 9th day the ducts of male embryos promptly undergo involution. However, if the Müllerian ducts of female embryos are cultured in the presence of an embryonic testis, a typical involution takes place (although at the same time the adjacent Wolffian ducts develop normally). Furthermore, when testosterone propionate is added to the medium it has the same effect as the embryonic testis (Wolff, Lutz-Ostertag and Haffen, 1952; for a summary see Wolff, 1953b). These results hardly leave the role of the male hormone in doubt. It follows also that the action of the hormone *in vitro* must be direct. Evidence has been obtained to show that the process of involution of the ducts is of the nature of an autolysis produced by the action of proteolytic enzymes which are presumably activated by the male hormone (Wolff, 1953b).

*Summary and conclusions.* On the basis of present knowledge, the following general statements may be made concerning the role of sex hormones in the differentiation of the Müllerian ducts.

a. *Female hormone*, in most species, stimulates precocious growth and development of the Müllerian ducts and their derivative structures in embryos of either sex when given in adequate dosages. Administered at an early stage it prevents the normal involution of the ducts in male embryos after which development may continue without further treatment. In certain mammalian species, however (hamster, field mouse, man), negative results have been reported, which may possibly be related to the level of estrogen prevalent during gestation in these species or to dosage.

b. *Male hormone*, if administered early, has an inhibitory action on the Müllerian ducts in the embryos of birds and amphibians. In some species the primary development of the duct is entirely suppressed; in other cases only a partial inhibition occurs. In mammals, the hormone of the embryonic testis produces involution of the ducts in males at the beginning of sex dif-

differentiation, and testis grafts inhibit the Müllerian ducts of females; on the other hand, male hormones of adult type fail to inhibit the ducts, or produce only a limited and localized involution in a few species.

e. The *time factor* is critical in the hormonal control of the Müllerian ducts. To suppress primary differentiation of the ducts in birds and amphibians, male hormone must be administered before or during the formative stage of development. However, the fully formed duct remains sensitive to hormones up to the onset of sex differentiation. Female hormone administered before this stage insures retention and development of the ducts in males, and during the same period they are subject to inhibition by male hormone or by the embryonic testis. Beyond this point the final development or the involution of the ducts has been irreversibly determined and hormones are without effect.

d. In the absence of previous hormonal conditioning, as after early castration or early isolation *in vitro*, the Müllerian ducts of either sex are capable of an autonomous differentiation, comparable to development in normal females; this development can be prevented, however, and involution induced, by introduction *in vitro* of an embryonic testis, or (in birds) by the addition of male hormone to the medium.

e. In amniote embryos the *testis hormone* is the controlling factor in the differentiation of the Müllerian ducts. The involution of the ducts in males is conditioned by the testes, whereas in the absence of gonads there is an almost normal development of the ducts in embryos of either sex. This does not mean, however, that the embryonic Müllerian ducts are insensitive to female hormone; in sufficient concentration it produces hypertrophic development in both sexes.

f. The evidence from cultivation *in vitro* shows that the effects of hormones on the Müllerian ducts are exerted directly and are independent of the organism as a whole.

## 2. The Male Duct System

The male sex duct, or *Wolffian duct*, develops first as the duct of the pronephros (primary nephric duct) and subsequently

serves as the *mesonephric duct* in both sexes. As the mesonephros is replaced by the metanephros in amniote embryos, the Wolffian duct loses its excretory function and its fate in the two sexes is different. In the female it disappears entirely or survives only as vestiges, but in males it acquires a new status as the male sex duct. At the same time a certain number of mesonephric tubules, which connect the duct with the rete canals of the testis, become a part of the epididymis, and the seminal vesicle develops as a diverticulum of the duct near its junction with the urinogenital sinus. During its early history as the duct of the mesonephros the Wolffian duct is unresponsive to sex hormones, but with the onset of sex differentiation it becomes responsive to the male hormone.

*The role of male hormone in the differentiation of the Wolffian ducts.* In the female of amphibians experimental transformation of ovaries into testes is followed by hypertrophy and masculinization of the Wolffian ducts (Humphrey, 1942), and transplantation of testes into larval castrates of either sex has the same effects (de Beaumont, 1933). Administration of male hormones produces marked hypertrophy of the Wolffian ducts in larval amphibians of either sex (*c.g.*, Burns, 1939c; Foote, 1941; for summary see Gallien, 1955). A similar response occurs in the embryos of birds and has also been reported in many species of mammals (Figs. 2.23, 2.24).<sup>15</sup> This is the case in female embryos as well as in males. Development of epididymal tubules (from the epoophoron) also takes place in females (Fig. 2.24D) which also commonly develop seminal vesicles (Greene, 1942; Raynaud, 1942; Wells and van Wagenen, 1954). With higher dosages all these structures undergo extreme hypertrophy.

*Female hormones*, on the contrary, appear to have little influence on the development of the Wolffian ducts, although in a few cases a partial involution of the ducts has

<sup>15</sup> This effect has been widely reported; see Willier (1939), Wolff (1938, 1950) for the chick; Greene (1942) for the rat; Raynaud (1942), Turner (1940) for the mouse; Jost (1947a) for the rabbit; Goddard (1949) for the mole; Burns (1939a and b, 1945a); and Moore (1941) for the opossum.

been reported (Raynaud, 1942; Greene, 1942). It should be noted that the latter observations are in mammalian embryos (mice and rats) in which the hormone of the testis (see below) is essential to insure retention of the ducts. Partial involution in males under the influence of a female hormone is possibly only a result of interference with the normal activity of the testis. On the other hand, a *paradoxical action* of female hormone, causing partial retention and hypertrophy of the male duct, has been occasionally reported (*e.g.*, Greene, 1942; Moore, 1941). Although the method of administration in these cases does not permit accurate estimation of the dosage it was evidently rather large. With these exceptions, the effects of sex hormones on the male duct system are consistent with theory.

*The effects of castration* on the development of the male sex duct are striking and agree with the results of hormone administration. They show that in all species the presence of the embryonic testis is necessary to induce sexual differentiation of the duct, and to insure its retention in mammalian embryos. In amphibian larvae (*Triturus*, syn. *Triton*) the Wolffian ducts persist after castration in their capacity as nephric ducts, but remain in a sexually undifferentiated condition (de Beaumont, 1933). In bird embryos also there is no significant alteration of the Wolffian ducts after castration. It is in mammals that the ducts become dependent on the testis and its hormone for *survival* as well as for sexual differentiation. In rabbit embryos castrated before the 22nd day of gestation (Jost, 1947b) the ducts in both sexes completely regress, following the female pattern of development (Fig. 2.26); involution in castrates is prevented, however, and normal development is maintained by prompt administration of male hormone. A more variable atresia of the ducts also occurs in fetal rats after castration (Wells and Fralick, 1951). In mice Raynaud reports a difference in reaction in the two sexes. After castration the Wolffian ducts of males undergo a complete involution but they may be partially retained in females. It is suggested that in this species the ovaries may play a positive role in the involution of the duct in females (Raynaud, 1950).

*The development of the Wolffian ducts in vitro.* Further evidence that retention and sexual differentiation of the Wolffian ducts and associated structures (epididymal tubules and seminal vesicles) are dependent on the testis and its hormone is provided by the behavior of the male duct system after isolation, using the technique of organ culture. Development in isolation provides a parallel to development in the castrate fetus, with exclusion, however, of possible influence by hormones of maternal or placental origin or from some extragonadal source in the fetus.

When the mesonephric bodies of rat embryos, including long segments of the gonaducts, are removed at 15 to 16 days of gestation and cultured without the gonads, the Wolffian ducts of both males and females degenerate, but at the same time the Müllerian ducts survive and develop normally. The degeneration of the Wolffian ducts cannot, therefore, be due to unfavorable conditions in the medium (Jost and Bergerard, 1949). The same result was obtained using slightly older fetuses of  $\pm 16.5$  days (Jost and Bozic, 1951). However, the most complete study of this question is that of Price and Pannabecker (Price, 1956; Price and Pannabecker, 1956) who explanted male genital tracts of 17.5-day rat fetuses under various conditions designed to test the role of the embryonic testis and the male hormone. When both testes are included with the explant, development of the male duct system proceeds normally up to an age of 21.5 days (approaching term for the normal fetus) and the seminal vesicles develop as usual. Normal development ensues also when only one testis is left with the implant. But if one testis is removed and the lateral halves of the genital tract are spread widely apart on the surface of the medium, development is normal only on the side where the testis is present; on the other side serious defects appear; the duct is thin and weakly developed, and the seminal vesicles are small or even lacking. Finally, if both testes are removed the Wolffian ducts regress completely. However, the addition of male hormone to such a preparation fully compensates for the absence of the testes and development of the male duct system is again normal.

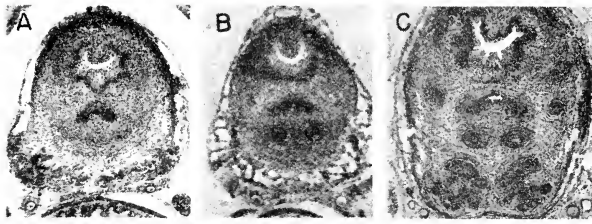

FIG. 227. The effects of castration on the development of the prostatic glands in the rabbit. *A.* The sinus region in a male fetus, aged about 27 days, castrated before the 20th day of gestation; above is the canal of the urinogenital sinus, below it the dark, bilobed structure represents the vaginal cord as it unites with the wall of the sinus. No sign of prostatic buds is seen. *B.* The sinus region in a young male of the same age castrated at about 21 days (20 days, 20 hours). Two large prostatic buds are seen ventral to the vaginal cord which were present at the time of castration. No further development has occurred. *C.* The sinus region in a male fetus of 28 days, castrated at the age of 23 days. Castration at this age is followed by essentially normal development. (From A. Jost, *Arch. Anat. microscop. et Morphol. expér.*, **36**, 271-315, 1947.)

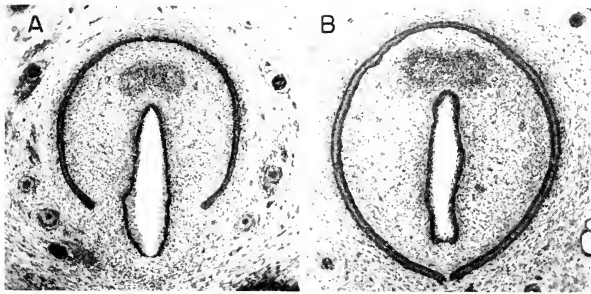

FIG. 228. Histologic differences between normal female (*A*) and male types of external genitalia (*B*) in rabbit fetuses after sexual differentiation. The urinogenital meatus is larger in the female, and is only partly surrounded by the preputial fold, which marks off the *glans clitoridis* from the surrounding tissues. In the male the urethral cleft is narrower and completely enclosed within the preputial fold. The paired erectile bodies are seen above the urethral cleft. Castration at an early stage always results in genitalia of female type (*A*) regardless of the sex of the castrated embryo. (From A. Jost, *Arch. Anat. microscop. et Morphol. expér.*, **36**, 271-315, 1947.)

Altogether, the evidence clearly indicates that the male hormone is the essential determining factor in the survival and sexual differentiation of the male sex ducts and seminal vesicles. Notwithstanding the minor exceptions noted above, the female hormone evidently has little role. The reason for the insensitivity of the Wolffian ducts to the female hormone may possibly be found in their long phylogenetic history as nephric ducts in both sexes, in which capacity they must be retained in some groups beyond the period of sex differentiation or even permanently.

#### B. DERIVATIVES OF THE CLOACA AND URINOGENITAL SINUS

Sexual dimorphism of the amphibian cloaca chiefly takes the form of special cloacal glands which in males become highly developed at the breeding season, causing the prominent swelling of the cloacal region so conspicuous in males. In the females of various species they may be absent, present in a rudimentary state, or in some cases differently specialized (Noble, 1931). For their development and maintenance these glands depend almost entirely on the testis. After experimental transformation of sex, the subsequent differentiation of the cloacal glands

TABLE 23

*Effects of hormones on derivatives of the urogenital sinus and the external genitalia in mammalian embryos*

## ACTION OF MALE HORMONE ON FEMALES

SUBJECT OF EXPERIMENT	FORM OF SINUS	VAGINAL DEVELOPMENT	SINUS EPITHELIUM	PROSTATE	FORM OF GENITALIA
OPOSSUM	MALE TYPE	SUPPRESSED IN 50% OF CASES	HYPERTROPHIC* BUT NOT CORNIFIED	HIGHLY DEVELOPED	MALE TYPE
RAT	MALE TYPE	SINUS PORTION SUPPRESSED		HIGHLY DEVELOPED	MALE TYPE
MOUSE	MALE TYPE	SINUS PORTION SUPPRESSED		WELL DEVELOPED	MALE TYPE
RABBIT	MALE TYPE	SUPPRESSED		WELL DEVELOPED	MALE TYPE
MONKEY	MASCULINIZED	SINUS PORTION SUPPRESSED	STRATIFIED SQUAMOUS	LARGE OR VARIABLE	MASCULINIZED—PENIS-LIKE

## ACTION OF FEMALE HORMONE ON MALES

OPOSSUM	FEMALE TYPE	SINUS PORTION HYPERTROPHIC	VAGINAL TYPE, HIGHLY CORNIFIED	COMPLETELY SUPPRESSED	FEMALE TYPE
RAT	FEMALE TYPE	SINUS PORTION WELL DEVELOPED		SUPPRESSED	FEMALE TYPE
MOUSE	FEMALE TYPE	VAGINAL CORD WELL DEVELOPED	STRATIFIED SQUAMOUS—METAPLASTIC	SUPPRESSED	FEMALE TYPE

\* This effect appears only with large dosages

corresponds to the altered sex of the gonad. Castration of mature males results in retrogression of the glands and after early castration the cloaca remains sexually undifferentiated in both sexes (de Beaumont, 1933). However, testis tissue grafted into castrates (de Beaumont), or treatment with male hormone (e.g., Burns, 1939c), readily induces development of male cloacal glands in individuals of either sex (for a review see Humphrey, 1942).

In the development of mammalian embryos the *urinogenital sinus* is separated at an early stage from the cloacal region of the hind-gut by formation of the perineal septum. In its primitive condition the sinus is a short canal, extending from the neck of the bladder to the exterior, with a meatus at the base of the genital tubercle. The paired gonaducts open into it near the neck of the bladder (Fig. 2.22). Sexual differentiation in females chiefly involves anatomic and histologic changes associated with development of the vagina, to which the urinogenital sinus makes an important contribution; at the same time the male sex ducts regress and largely disappear (Fig. 2.22B). In *placental mammals* fusion of the posterior ends of the Müllerian ducts as they approach the urinogenital sinus gives rise to the unpaired, median vagina, but in *marsu-*

*pials* the ducts remain separate and paired lateral vaginal canals are formed (Fig. 2.22B). In male embryos the main features of sinus differentiation are the involution of the Müllerian ducts with absence of vaginal development, and the differentiation of elaborate prostatic glands. Sex hormones show a high degree of specificity in their effects on the sinus structures, inducing development of typically male or female forms. Results are available for a number of species belonging to several orders of mammals,<sup>16</sup> and are in agreement except for minor details (for some representative species see Table 2.3).

The histologic aspects of the differentiation of the sinus are well illustrated in young opossums. *The effects of male hormone* (testosterone propionate) in male and female pouch young are compared in Figure 2.29. The effect of the hormone in males is

<sup>16</sup> See Greene (1942) for the rat; Raynaud (1942), Turner (1940) for the mouse; Jost (1947a) for the rabbit; Godet (1950) for the mole; Wells and van Wageningen (1954) for the monkey; Burns (1939a, b) and Moore (1941) for the opossum. Summaries for these and other species are to be found in *Colloques Internationaux: La Différenciation Sexuelle chez les Vertébrés*, Masson et Cie., Paris, 1951. As an exception, the effects in the hamster are rather slight (Bruner and Witschi, 1946; White, 1949).

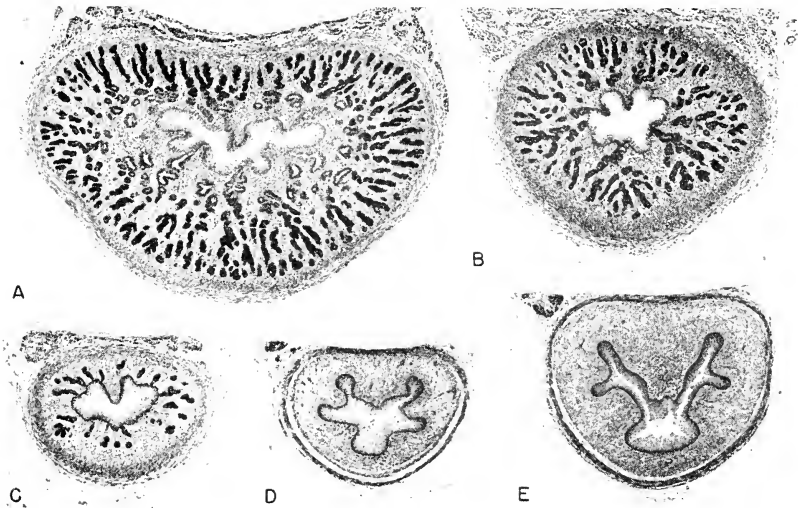

FIG. 2.29. The effects of testosterone propionate on the development of the urinogenital sinus and prostatic glands in young opossums. A. Extreme hypertrophy of the sinus and prostate in a male aged 50 days, treated from birth; compare with the condition in a normal male of the same age (C). The effect of the same dose of hormone in a littermate female is shown in B. Female opossums normally never develop prostatic rudiments, as shown in D and E, representing cross-sections through the urinogenital sinus somewhat below (D) and at the point of junction (E) of the lateral vaginal canals (cf. Fig. 2.22B). Note the great difference in the volume of prostatic tissue in the treated male (A) as compared with the treated female (B), although dosage and other conditions were the same.

merely to exaggerate the normal processes of development. With large doses there is a moderate hyperplasia of the sinus epithelium in males and a tremendous hypertrophy of the prostatic glands. But in females a striking development of prostatic glands also occurs (although normally the female possesses no prostatic rudiments) together with a change in form, resulting in a sinus that is typically male. Quantitatively, these effects are proportional to dosage, but with the same dosage an interesting sex difference is constantly observed with respect to the magnitude of the response. The prostate (Fig. 2.29A, B) is invariably more strongly developed in male subjects than in females. This difference in size apparently depends on an inherent difference in growth capacity in homologous tissues of different sex genotype when exposed to the same intensity of stimulation (Burns, 1942b, 1956a). This effect appears regularly in the case of many other sex structures of the

opossum as will be seen. The induction of prostatic glands and a male form of sinus is of regular occurrence in female mammalian embryos exposed to male hormones (Table 2.3).

Two special points concerning prostatic differentiation in young opossums are of interest. Brief treatment of female embryos with androgen, just at the time when the prostatic buds are appearing in males, is sufficient to induce buds which are then capable of continued differentiation after the hormone is withdrawn (Moore, 1945). This is an unusually clear case of permanent conditioning of a sex structure by brief exposure to a hormone at a critical stage in development. Also of interest is the fact that by gradually reducing the dosage of male hormone a level is reached, at approximately 5  $\mu\text{g.}$  per day, which induces prostatic buds in young females which are identical in size and appearance with those of normal males of the same age (Burns, 1942a). With-

out attempting to allow for the constitutional sex factor mentioned above, this amount of androgen would appear to be roughly equivalent to the hormonal activity of the embryonic testes at this period.

*Female hormone* has opposite effects on the urinogenital sinus and its derivatives in young opossums. Estradiol dipropionate completely suppresses prostatic differentiation in males and transforms the sinus epithelium into a stratified squamous epithelium of vaginal type (Fig. 2.30); in fact the histologic picture is one of intense proliferation and cornification like that of the adult vagina at estrus. Moreover, a single dose of estrogen administered during the 15th day of pouch life, shortly before the prostatic buds would normally appear, results in complete suppression of the prostate, an effect which is also permanent (Burns, 1942a, b, c). Thus, there is a relatively short period during which induction and continued development of prostatic glands in females, or their

permanent suppression in males, is wholly conditioned by the presence of the appropriate hormone. Quantitatively as well as qualitatively the reactivity of the embryonic sinus epithelium to estradiol is remarkable. Again a sex difference, as measured by growth and proliferation is seen, this time in favor of the female. Transformation to a typical vaginal epithelium in the estrous phase can be induced in very young male embryos, long before the time of appearance of prostatic buds (Fig. 2.31; Burns, 1942e). It is hardly surprising that an epithelium of this type permanently loses all capacity to produce prostatic tissue.

*The effects of castration* on the development of the urinogenital sinus and its derivatives in mammalian embryos follow the pattern previously described for the sex ducts. The male form of sinus is incapable of developing in the absence of the testes, whereas morphogenesis of the female form is not significantly affected by castration

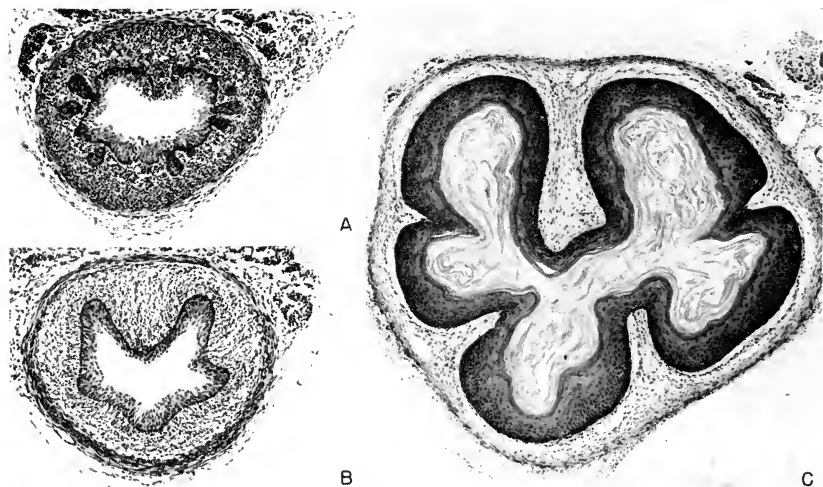

FIG. 2.30. The effects of *estradiol dipropionate* on the development of the urinogenital sinus and prostate in young opossums. A. The normal sinus of a young male aged 30 days, showing the condition of the prostatic buds, for comparison with a normal female of the same age (B). Note the bilobed form of the sinus canal in the male as compared with the typical pentangular form in the female. C. The effect of the female hormone in a male littermate of the same age, treated from the time of birth. Complete suppression of the prostatic glands has occurred, the form of the sinus canal is typically female, and the sinus epithelium has been transformed into a thick stratified squamous epithelium, like that of the adult vagina, in a state of pronounced keratinization and desquamation. The effect of an identical dose in a female subject is similar but much more intense.



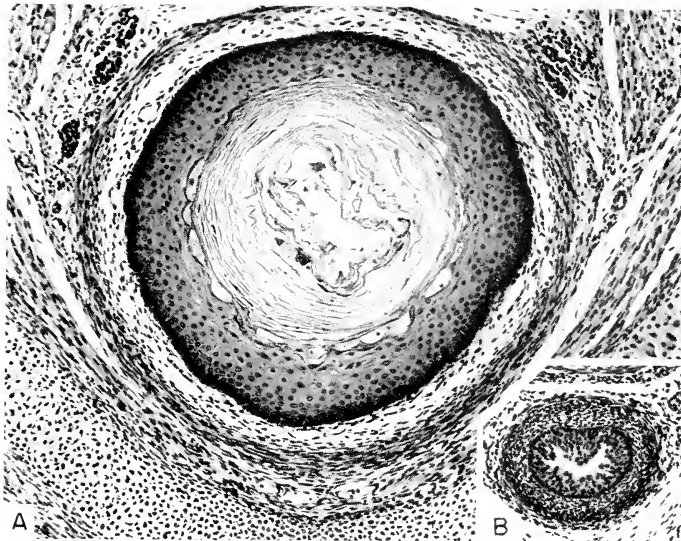

FIG. 2.31. The effects of a stronger dosage of estradiol dipropionate on the urinogenital sinus at a much earlier stage. *A*. Young male treated from birth to an age of about 12 days, for comparison with the normal male sinus (inset, *B*) of the same age. Compare the character of the sinus epithelium with that in the older specimen shown in Figure 2.30*C*. This condition of the sinus epithelium is induced at an age which precedes by several days the normal appearance of the prostatic buds, which never develop.

(Table 2.2; Jost, 1947*b*; Raynaud and Frilley, 1947; Wells, 1950). In castrate males prostatic differentiation is prevented and development of a vagina (correlated with persistence of the Müllerian ducts in male castrates) results in a sinus of female type (Fig. 2.27*A*). Male and female castrates are morphologically very similar, and both closely resemble the normal female. Again it is clear that the embryonic testis is the essential factor in male development, whereas the female pattern is independent of hormonal conditioning and also of sex constitution, since in the absence of the gonads it develops spontaneously in castrates of either sex.

The factor of time is again of paramount importance and sharply limits the effectiveness of castration. This holds for the development of other accessory structures (Table 2.2) but is particularly clear in the case of the prostate which will serve to illustrate. In male rabbit embryos castrated on or after the 23rd day of gestation there is only a

slight effect on prostatic development, which continues in a practically normal manner; but if the operation is performed a day earlier there is a distinct reduction in size. In fetuses castrated from the 20th to the 21st day only small ventral buds are found which are already formed at the time of operation, and after castration earlier than 20 days prostatic buds are absent altogether (Fig. 2.27; Jost, 1947*b*, *c*). The period from 20 to 21 days, then, is critical for the appearance of the prostatic buds and their further differentiation for which the embryonic testis is essential. However, absence of the testis is fully compensated for by male hormone; in castrates receiving androgen the development of all male parts proceeds normally. A similar result has been obtained in the fetal rat (Wells, Cavanaugh and Maxwell, 1954). Late castration has little effect, but castration on day 18 results only in buds which do not undergo branching. Earlier castration has not proved feasible in this species.

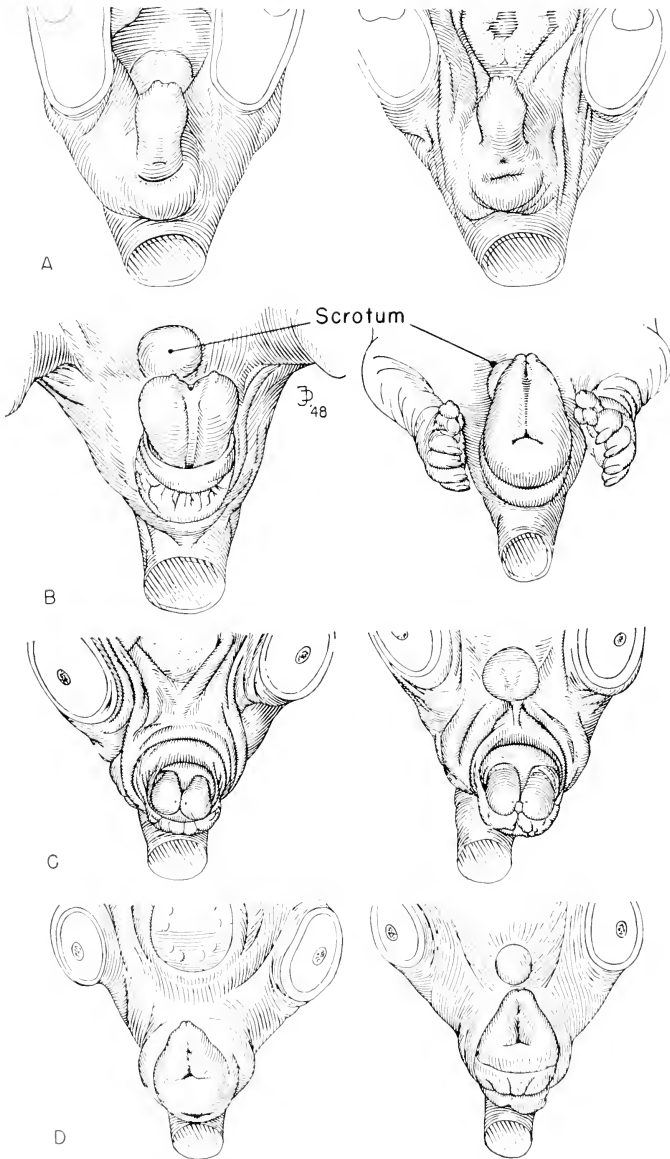

FIG. 2:32. The effects of sex hormones on the sex type of the copulatory structures in young opossums. A. The appearance of the phallus, or genital tubercle, in a normal male (left) and female opossum aged 20 days. Sex is difficult to distinguish by form alone but the phallus is somewhat larger in the male. Sex is readily distinguished at this age, however, by

## C. EXTERNAL GENITAL STRUCTURES

Copulatory organs homologous with those of higher vertebrates are not found in amphibians. They are developed to an extent, however, in certain birds and reptiles and become highly specialized in mammals. The copulatory organ in amniote embryos develops from a simple primordium, the *genital tubercle*, which is common to both sexes. It becomes specially developed as the penis in the male but in females it persists in a more or less rudimentary form, known in mammals as the clitoris. The *genital tubercle* of birds arises as a small, conical protuberance just within the cloacal orifice. In chickens it is not highly developed, although larger in the male than in the female, but in the males of ducks, geese, and certain other birds it becomes considerably larger and more modified, constituting a penis (Fig. 2.25). In the embryos of mammals (except the *Mono-tremes*) the genital tubercle is external in position, arising as an eminence near the ventral rim of the urinogenital meatus.

The developing copulatory organs of birds and mammals react readily to sex hormones and are extremely sensitive to castration. In birds the clearest experimental results have been obtained in duck embryos, because of the more pronounced sexual dimorphism in this species. *Treatment with female hormone* (estradiol benzoate) before the 12th day of incubation completely arrests development of the penis in males, and the rudimentary clitoris of the female may be even smaller than normal (Wolff, Em., 1950); beyond this age, however, the hormone is no longer effective, the form of the prospective penis having been finally determined. *The effects of the male hormone* are less precise and it is not essential for normal development (see the effects of castration below). Testosterone propionate produces great hypertrophy but

the structure is not entirely normal, the characteristic spiral form of the penis being imperfectly developed (Wolff, Em., 1950). This abnormality is perhaps a result of overdosage as the dosages used were undoubtedly very large. Although in the chick the dimorphism of the genital tubercle is less pronounced than in the duck, it reacts in the same way; male hormones stimulate and female hormones inhibit growth and morphologic differentiation (Reinbold, 1951).

In mammalian embryos the sex type of the developing genital tubercle, or phallus, is easily controlled by sex hormones (Table 2.3); in fact, this structure is unusually susceptible to modification and may be completely transformed. Typical are the results in the rat (Greene, 1942), the mouse (Raynaud, 1942; Kerkhof, 1952), the hamster (Bruner and Witschi, 1946) and in pouch young of the opossum (Burns, 1939a, b; Moore, 1941). The rat and the mouse are similar in their behavior. Male hormone does not affect the development of the penis in males except to produce hypertrophy, but in females the genital tubercle is greatly enlarged and assumes the character of a penis.<sup>17</sup> Female hormone has opposite effects; females differentiate normally but in males the tubercle fails to enlarge and a hypospadic condition frequently appears.

In young opossums the form of the copulatory structures is completely controlled in accordance with the type of hormone given, with results which are identical in the two sexes except for a difference in size (Fig. 2.32). The basis for the transformation of the phallus has been analyzed histologically (Burns, 1945b). The various histologic con-

<sup>17</sup> Strangely enough this is not typically the case in freemartins. The clitoris as a rule is not greatly modified (Lillie, 1917). There are, however, some striking exceptions (Buyse, 1936; Numan, 1843, illustrated in Lillie, 1917, Fig. 29).

the scrotal sac in males and the presence of the pouch folds and mammary rudiments in females. *B.* The typical form produced by male hormone (left) and female hormone in specimens treated from birth to an age of 20 days; the normal condition at this age is shown above. This striking difference in form is produced without regard to the sex of the subjects, which in this case are both male (note the scrotal sacs). *C.* The result of administering male hormone (*testosterone propionate*) from birth to an age of 50 days, in a female subject (left; note the pouch) and a male littermate. Observe the identity in form but distinctly greater size of the penis in the male. *D.* Comparison of the effects of estradiol dipropionate, given from birth to an age of 30 days, in a female subject (left) and a male littermate. In both *C* and *D* it is shown that the hormones produce genitalia of typical male or female form, regardless of the sex of the subject.

stituents of the organ respond to the appropriate hormone in a highly specific manner. The *erectile bodies*, the development of which largely determines the form and the size of the penis, are strongly stimulated by male hormone and almost entirely inhibited by female hormone (Fig. 2.33). Qualitatively, these responses are independent of sex constitution, but with identical dosages marked differences in size, such as were

noted previously in the case of the prostate, the sinus epithelium and derivatives of the sex ducts (Figs. 2.29 and 2.24), are again observed in the two sexes. Female hormone, in addition to inhibiting the erectile tissue, induces an extreme hyperplasia of the vulvar and periurethral connective tissues (Fig. 2.33*B*). It is this response which produces the gross swelling of the vulvar region, so conspicuous in estrogen treated embryos of

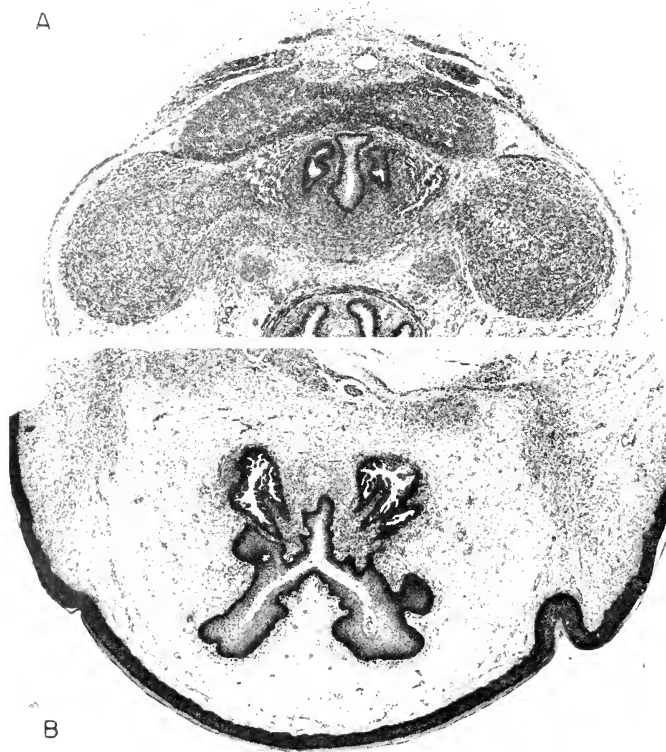

FIG. 2.33. The effects of male and female hormone on the differentiation of the histologic constituents of the phallus in young opossums. *A*. The effects of androgen in a male, aged 30 days, treated from birth onward. There is great hypertrophy of the erectile bodies but otherwise structure is normal; at the top, the paired corpora cavernosa are united at the mid-line; below, the urethral canal, with the bulbo-urethral glands on either side; laterally, the large bulbs of the corpora spongiosa, with their muscular investments. *B*. The effects of estrogen in another male littermate. The erectile bodies are almost completely suppressed and there is an enormous hyperplasia of the periurethral connective tissue. The urethral canal (urinogenital sinus) is greatly enlarged, as in a female, and the sinus epithelium is transformed into stratified squamous epithelium like that of the fully developed vaginal canals. The sex of the subject makes no difference in the character of these responses.

both sexes (Fig. 2.32). With increasing dosages all these effects are accentuated.

The phallic structures of mammalian embryos react to castration according to the pattern already established for the sex ducts and the prostate (Jost, 1947b; Raynaud and Frilley, 1947). In both sexes castration is followed by development of external genitalia of female type (Fig. 2.28; Table 2.2); the male type of differentiation is dependent on the testis whereas the female form is capable of developing without hormonal conditioning, in a somatic or asexual manner.

At this point it will be useful to recapitulate for mammalian embryos the effects of castration, or of early isolation, on the development of the genital system as a whole. It has been shown that in the absence of the gonads, or of any hormonal conditioning, the embryonic sex primordia collectively follow the female pattern of development. In all castrates, regardless of sex, the external genitalia and the derivatives of the urogenital sinus are of female type, the Müllerian ducts persist and continue to develop in a virtually normal fashion, whereas the Wolffian ducts undergo involution. Thus castrates of either sex toward term have female genital systems which are anatomically complete and almost as well developed as in normal females.

It is noteworthy that the pattern of development observed in castrate fetuses corresponds closely with a condition in human subjects known clinically as *gonadal dysgenesis*. Individuals presenting this anomaly either lack gonads entirely or show evidences of gonadal atresia at an early stage of development. Regardless of chromosomal sex as established by the Barr test (Barr, 1957) they possess external genitalia of female type and female genital tracts which, however, are of infantile proportions. Recent evidence indicates that some individuals of this type may lack the Y-chromosome, being of XO constitution (Ford, Jones, Polani, de Almeida and Briggs, 1959; chapter by Gowen).

In bird embryos the effects of castration on the genital tubercle are similar except that the sex relation observed in mammals is reversed; in this group the male form of the

organ corresponds to the asexual condition, which develops without hormonal conditioning in castrates of both sexes (Fig. 2.25; Wolff and Wolff, 1951). This is not an exceptional finding; it corresponds with the behavior of various other avian sex characters, such as the syrinx (*q.v.*), the spurs, and the sex plumage in species such as domestic fowl. The transposed relationship seen here is in line with the dominant role played by the grafted ovary and the greater potency shown by the female hormone in producing sex reversal in the gonads of the chick.

The developmental behavior of the genital tubercle after isolation *in vitro* has been studied in the duck, with results which correspond with those of castration. Isolated at 7 to 9 days of incubation, before the beginning of sex differentiation in the gonads, primordia of the genital tubercle always assume the male form as in castrates, regardless of the sex of the donor. By the 10th day, however, the sex type has become fixed, and when isolated after this stage differentiation always follows the sex genotype (Wolff and Wolff, 1952b).

#### D. DIFFERENTIATION OF OTHER TYPES OF SEX CHARACTER

Two further examples will be considered as illustrations of the role of hormones in the development of sex characters of quite different type, the mammary glands, and the syrinx of birds. The mammary glands of field mice have been extensively studied by Raynaud (for a summary see Raynaud, 1950). The rudiments of the glands first appear as bud-like ingrowths of the epidermal epithelium which penetrate the underlying mesoderm but retain a connection with the epidermis by a constricted neck (Fig. 2.34A, B). This phase of development follows the same course in both sexes. Toward the 16th day of gestation differences appear in males which coincide with the beginning of masculinization of the female genital tract; the mammary buds lose their connection with the epidermis and remain as isolated epithelial nodules in the mesenchyme (Fig. 2.34C). In females, on the contrary, the buds retain their attachment to the epidermis, and as development continues a circular fold appears surrounding the mammary rudiment which leads to elevation of the nipple.

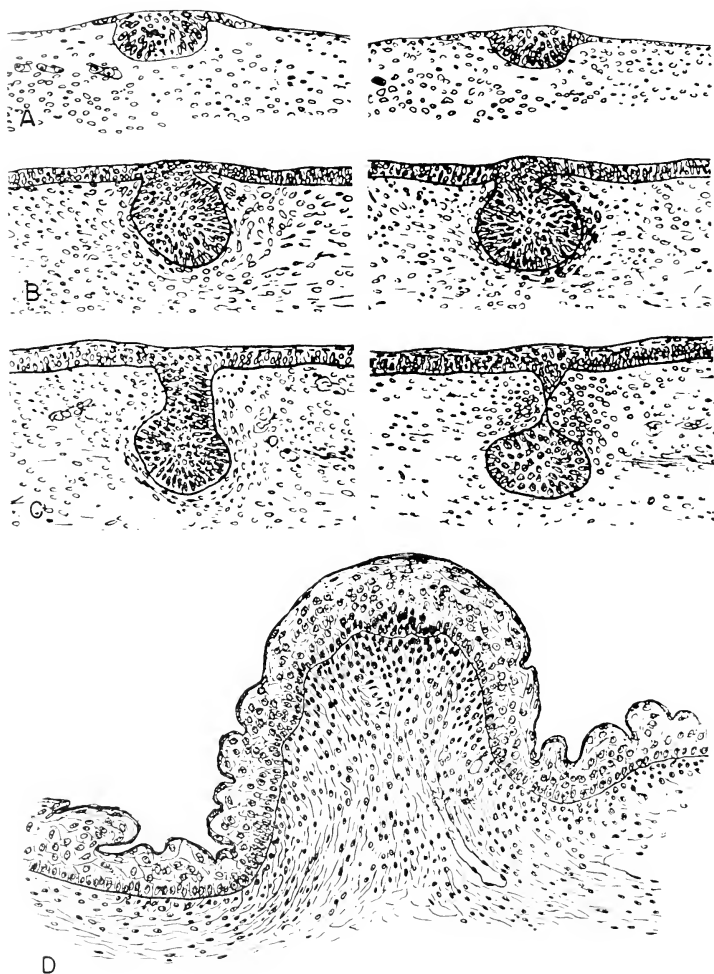

FIG. 234. The normal development of the mammary rudiments in embryos of the field mouse, and the effects of sex hormones (for a summary see Raynaud, 1950). *A.* Early appearance of the mammary thickenings in the female (left) and the male (right). *B.* Later stage, showing growth of the mammary primordia and penetration into the mesenchymal layer. *C.* Stage of sexual differentiation: in females the mammary rudiment remains attached to the epidermis and the nipple later develops at this point; in males the rudiment becomes detached from the epidermis and persists as a small epithelial nodule in the underlying mesenchyme. For the effects of hormones and of castration on this pattern see text. *D.* Nipple development in a male embryo induced by treatment of the mother with estradiol dipropionate. For details see text. (After A. Raynaud, *Arch. Anat. microscop. et Morphol. expér.*, **39**, 518-569, 1950.)

*Treatment with sex hormones* during the latter half of gestation shows that the processes described above are readily controlled or reversed experimentally. In female fetuses of mothers injected with male hormone, development of the mammary gland follows the male pattern; the mammary buds separate from the epidermis and persist only as nodular rudiments, the nipple fold does not appear and nipples fail to develop. The female pattern of differentiation is converted completely to the male type. The use of female hormones, on the other hand, leads to a somewhat paradoxical result; there is an inhibition of the mammary buds rather similar to that exerted by androgen, but nipple development on the contrary is strongly stimulated (Fig. 2.34D). The dosages were large, however, and the effects of female hormones under more physiologic conditions have not as yet been determined. With respect to development of the nipple similar results have been reported in the laboratory mouse (Greene, 1942); male hormone completely inhibits the nipples in females whereas female hormone induces typical development in males.

Of particular interest are the effects of castration on mammary development in mice. When the embryonic gonads are destroyed by irradiation the mammary glands continue to develop in both sexes according to the normal female pattern (Raynaud, 1950). This pattern obviously does not depend on the ovary but represents the asexual or anhormonal type of development. Its appearance in castrate males indicates that the regression of the mammary glands in the male is normally determined by the testis. This is in agreement with the results of administering male hormone, as described above. Once more the predominant role of the male hormone in mammalian sex differentiation is demonstrated.

An entirely different type of sex character, and one which exhibits sexual dimorphism in a striking way, is the syrinx of birds. This organ has received special study in the duck (Wolff, Em., 1950). The syrinx makes its appearance as a vesicular dilatation at the junction of the trachea and bronchial tubes, and at first it is small and symmetrical in form in both sexes. This is the permanent

condition of the syrinx in the female but in males a pronounced asymmetry soon appears, involving an enlargement of the left side of the vesicle with corresponding modifications of the cartilaginous rings. By the 10th day of incubation the asymmetry is extreme (Fig. 2.25). The appearance of dimorphism follows closely the beginning of sex differentiation in the gonads.

Experimental studies have shown that the dimorphism of the avian syrinx is conditioned by the ovary, or by the female hormone (Wolff, Em., 1950). Estradiol benzoate, introduced into incubating eggs, inhibits the development of the male syrinx and the female form appears. However, if large doses are used, or if treatment is too long delayed, a paradoxical result appears, consisting in the development of atypical and intermediate forms (Lewis and Domm, 1948). Male hormone (testosterone propionate) in moderate dosages has little effect on the syrinx (a slight enlargement may occur) but with large doses a paradoxical tendency is again found; the male syrinx is inhibited and may actually be reduced in size, resembling somewhat the female form.

*Castration* again reveals the dominant role of the female hormone in birds. In castrates of both sexes the form of the syrinx is male, both in size and in its asymmetry (Fig. 2.25); absence of the ovary is critical but the presence or absence of the testis is of no consequence in the sexual differentiation of this structure. In its response to castration the syrinx thus behaves like the genital tubercle.

The differentiation of the syrinx has also been studied *in vitro* (Wolff and Wolff, 1952a; Wolff, 1953a) with similar results. When explanted before the onset of sex differentiation, the result is the same as after castration; in an anhormonal environment the male form develops without regard to the sex of the donor. When explanted after the beginning of sex differentiation, however, development proceeds always in accordance with genotype. At this stage the form of the female syrinx has already been irreversibly determined. The syrinx developing *in vitro* responds directly to sex hormones introduced experimentally. Addition of estradiol benzoate to the culture medium,

has the expected result; regardless of sex constitution, only the female type of syrinx develops. But male hormone (testosterone propionate) under the same conditions produces, paradoxically, organs of female or of intermediate form. The dosages employed, however, were extremely large (5 mg. and 40 mg. per cc. solvent)<sup>18</sup> and in the light of the effects of large doses of androgen on the gonads and other structures the anomalous result is not surprising.

## VI. The Pituitary and the Differentiation of Sex

It does not appear that the anterior lobe of the pituitary is concerned in the primary differentiation of sex, *i.e.*, in the morphogenesis of the gonads themselves. Early hypophysectomy does not interfere with their histologic differentiation, up to the stage at least where they are fully characterized as ovaries or testes; neither is the process of differentiation appreciably delayed. Later, however, deficiencies of a secondary order may appear in the genital tracts of hypophysectomized animals; the development of various accessory sex structures may be considerably retarded but without any essential change in character. This effect is explainable as the result of diminished secretory activity on the part of the gonads through lack of adequate gonadotrophic stimulation. The question of when the functional interrelation between the gonads and the anterior pituitary is established has been reviewed by Willier (1952, 1955) with special reference to the chick, and Jost (1953, 1955) has dealt with this problem in mammalian embryos and fetuses. In each case gonadotrophic activity is evident shortly after the period of gonad differentiation and covers the period when the sex ducts and other accessory structures are differentiating. Some of the evidence on which these statements are based will be briefly reviewed.

In amphibian embryos or early larvae,

<sup>18</sup>Under the conditions of culture the explants develop in close contact with droplets of the hormone solution, and may actually be exposed to extremely high concentrations. Culture with the oil solvent alone, however, shows that the solvent is not the disturbing factor.

hypophysectomized long before the time of sex differentiation, the development of ovaries and testes proceeds normally and without appreciable delay until toward the end of the larval period (Smith, 1932, p. 752; Chang and Witschi, 1955; Chang, 1955). It is also well known that during larval life the gonads are capable of responding readily to gonadotrophic substances by rapid growth and precocious maturation of the germinal elements (*e.g.*, Burns and Buyse, 1931; Burns, 1934). During this period pituitary stimulation merely accelerates the normal processes of development and maturation. It has been shown previously that in many amphibian species administration of steroid sex hormones during the larval period induces transformation of the gonads; however, an interesting case is known in which sex hormones appear to be without effect unless a gonadotrophin is also administered (Puckett, 1939, 1940). The tadpoles of a so-called "undifferentiated race" of *Rana catesbiana* all have gonads which structurally resemble young ovaries until late in larval life, when differentiation of the males occurs rather abruptly. The administration of gonadotrophin alone to the undifferentiated tadpoles initiates sex differentiation precociously, the two sexes appearing in the usual 50:50 ratio. The administration of sex hormones of either type to tadpoles during the indifferent period is without effect; the gonads are apparently incapable of responding at this stage of development. However, when the sex hormone and gonadotrophin are administered concurrently a striking response occurs; not only is sex differentiation precipitated, as when gonadotrophin was administered alone, but a complete transformation of sex takes place, resulting in all males or all females, according to the type of sex hormone employed. The gonadotrophin is evidently necessary to initiate sexual differentiation but the type of differentiation which follows is determined by the type of sex hormone.

In chick embryos "hypophysectomy" before the onset of sex differentiation has been accomplished in two ways, by partial decapitation, in which the forebrain area is removed surgically after 33 to 38 hours of incubation (Fugo, 1940), and by irradiation



of the hypophyseal region (Wolff and Stoll, 1937). After excision of the forebrain, histologic differentiation of the gonads proceeds normally. Later, however, the interstitial tissue of the testis fails to develop or is deficient in quantity, and the cortex of the left ovary remains rather thin through failure of secondary sex cords to develop in the usual numbers. The development of the gonads, on the other hand, is normal in both sexes. Wolff and Stoll reported that, after destruction of the hypophysis by irradiation, differentiation of the gonads continued in a normal manner to the end of incubation and again the gonads were found to develop normally. Such embryos, moreover, undergo sex reversal in the usual manner when treated with sex hormones (Wolff, 1937). The available experimental evidence indicates, then, that the hypophysis has no appreciable part in the primary differentiation of sex, a conclusion which is supported by van Deth, van Limborgh and van Faassen (1956).

In mammalian embryos and fetuses, hypophysectomy has been carried out by procedures similar to those described for the chick, namely, partial or total decapitation and irradiation with x-rays. The former method was used on embryos of the rat (Wells, 1947, 1950) and the rabbit (Jost, 1947d, 1950, 1951a), and the latter on the embryos of the mouse (Raynaud and Frilley, 1947; for a summary see Raynaud 1950). In the case of the rabbit and the rat, the operation was not performed early enough to affect the primary differentiation of the gonads; in the mouse, however, irradiation on the 12th day of gestation, just at the beginning of differentiation, was without effect except for a certain reduction in the number of germ cells when the hypophysis was entirely destroyed. The results differed sharply, however, with reference to the condition of the *genital tracts* in hypophysectomized male rabbit fetuses, as opposed to those of the rat and the mouse. In the two latter species no significant changes in the development of the accessory genital structures were observed. It may be that in these species the entire process of sexual differentiation is independent of pituitary function, although the possibility is

perhaps not excluded that an extraneous gonadotrophin, of maternal or placental origin, may be substituted. In the rabbit, on the other hand, definite defects were found in the development of certain accessory genital structures, resembling those which follow embryonic castration but somewhat less severe. However, if gonadotrophin is administered following decapitation these deficiencies do not appear; they may therefore be ascribed to lack of gonadotrophic activity (Jost, 1951a, 1953). The defects observed vary in severity according to position; the anterior regions of the gonads and the epididymides, which are near the testes, develop normally, whereas distant structures such as the prostatic glands and external genitalia may be almost as severely affected as in castrate fetuses. This observation indicates that the testis is acting in an intermediary capacity. In the absence of the pituitary its humoral activity is diminished to a level adequate for normal differentiation of nearby structures but insufficient to maintain the development of more distant parts. The point has been previously established that after decapitation there is a decrease in the amount of interstitial tissue.

The problem of the time of onset of gonadotrophic function in its relation to gonad secretion and the differentiation of the genital tract has been studied in the rabbit by Jost (1951a). By examining the genital tracts of decapitated male fetuses at short intervals to determine when the first signs of abnormal development appear, and by varying also the age at which decapitation was performed, he was able to define rather closely the beginning of gonadotrophic function and the period during which it is critical for normal development of the genital structures. Following decapitation on the 19th day of gestation no marked defects in the genital structures appear until about the 22nd day, after which abnormalities become more and more pronounced until the 24th day. If decapitation is delayed until the 24th day no important anomalies are subsequently found. It should be recalled that the latter date coincides with the stage after which castration likewise has no effect on development. The interval from the 22nd

to the 24th day of development thus falls within the period during which testis activity is most essential for normal morphogenesis (p. 125).

In the light of these results the anterior hypophysis was studied cytologically for direct evidences of secretory activity, using the MacManus periodic acid-Schiff (PAS) test (Jost and Gonse, 1953; Jost and Tavernier, 1956). PAS-positive cells are first seen in small numbers, and faintly stained, on the 19th day of development. Thereafter they increase in numbers and in staining reaction, reaching a maximal development during the 22nd and 23rd days; on the 24th day these cells abruptly decrease in number and stainability and almost disappear. The peak of gonadotrophic activity, as indicated by the cytologic evidence, falls again during the 2-day period when the secretory activity of the testis is at its height, as judged by the consequences of castration, a remarkable example of endocrine correlation (for a fuller account see Jost, 1953, 1955).

It was once widely believed that in human anencephalic monsters the pituitary is absent or vestigial in character; more recent studies have revealed, however, that although difficult to identify grossly, anterior lobe tissue can usually be demonstrated by careful histologic examination (*e.g.*, Angevine, 1938). Nevertheless, cases are known in which apparently no anterior lobe tissue is present, and such cases are pertinent to the present discussion. Barr and Grumbach (1958, and personal communication of Dr. Grumbach) have described such a case in a newborn male infant, in which no malformation of the genital system was evident except that the testes were somewhat smaller than usual. They were not otherwise abnormal, however, and interstitial tissue was present. In a similar case, also a male, reported by Blizzard and Alberts (1956), the external genitalia were small but normal in structure. The testes also were small and undescended, lying in a pelvic position, the tubules were somewhat atrophic and no interstitial tissue was present. No other abnormalities were noted. It is perhaps significant in this case that absence of the interstitial cells is correlated with underdevelopment of the external genitalia and

failure of the testes to descend. In two cases of congenital absence of the hypophysis, a male and a female (Brewer, 1957), development of the gonads and genital system was apparently normal.

Cases in which complete absence of the pituitary has been demonstrated are unfortunately few but of great value since they represent in humans the closest approach to hypophysectomy in experimental animals. The consequences of the deficiency and the conclusions to be drawn in the two cases are similar; the primary differentiation of the gonads is evidently independent of the pituitary but secondary defects may appear later, both in the gonads and in the genital tract. The testes may be underdeveloped, the tubules may show secondary atrophy or degenerative changes, and the interstitial tissue may be reduced or lacking, but in some cases it appears to be well developed. There is need for a careful correlation of the status of the interstitial tissue in such cases with the presence or absence of defects of the accessory organs. The consequences to the gonad of absence of the pituitary may hinge on whether a secondary source of gonadotrophin is available to the fetus (Jost, 1953). This is a matter which may be expected to vary in different groups or species. As yet too few species have been studied to clarify the point.

## VII. Group Differences in the Relations of Hormones to Sex Differentiation

The extensive experimental data reviewed in the foregoing pages show clearly that the *embryonic gonads* produce sex specific substances which must be regarded as hormones and which act as physiologic agents in the differentiation of sex, controlling not only the development of the various accessory sex structures but in many cases the differentiation of the gonads themselves. That the substances are hormones in the usual sense is shown by the fact that they regulate the development of distant structures in such fashion that they can only be distributed by way of the circulating blood. This, however, does not preclude a sharply localized action under proper circumstances. That they are elaborated in the gonads is demonstrated by

many types of grafting experiments, and above all by the results of embryonic castration. At the same time, steroid hormones of the adult type are also capable in many cases of reproducing closely the effects of the embryonic hormones, thus suggesting a basic similarity. This is not to say, however, that in all groups and species the role of hormones in the differentiation of sex is the same, either with respect to their effects on individual structures or their part in the differentiation process as a whole. Along with ontogenetic processes in general, hormonal relationships have evolved differently in the different vertebrate groups.

*Amphibians.* In amphibians both sex hormones seem to have active and essentially coordinate roles in sexual differentiation. With respect to gonad differentiation, grafted gonads of opposite sex induce transformation of both testes and ovaries by acting selectively on the appropriate gonad components. In many cases the interacting gonads are reciprocally modified, both becoming strongly intersexual; when this reciprocal effect does not occur it is apparently due to the decisive predominance of one member. Moreover, the gonad components in many cases react in a similar or identical manner to both natural and synthetic hormones. Male hormones induce precocious differentiation of the male duct system and the cloacal glands in individuals of either sex and when administered early may also completely suppress the development of the Müllerian ducts; conversely, female hormones stimulate differentiation of the Müllerian ducts but are without effect on such male structures as Wolffian ducts and cloacal glands. But if such evidence demonstrates beyond question that the larval sex structures are capable of reacting specifically to hormones of the proper type, the role of hormones in the normal differentiation of sex is more directly demonstrated by the effects of larval castration. In castrates of either sex the gonaducts and other sex accessories remain indefinitely in an undifferentiated or slightly differentiated condition. The sexually neutral type in amphibians thus tends to be morphologically intermediate between the sexes; however, either sex type may be readily obtained

from the castrate type by transplanting an ovary or a testis (p. 112). The positive role of both hormones in sex differentiation is apparent.

*Birds.* In bird embryos also steroid sex hormones stimulate precocious growth and differentiation of the appropriate sex primordia, and in general have inhibitory effects on structures of the other sex. There is a high degree of specificity in the interaction between hormone and end organ, and from the results of hormone administration alone it might be inferred that the two hormones have coordinate roles in sex differentiation. However, the results of castration show clearly that the roles of the two hormones are different and unequal. The Müllerian ducts persist and continue to develop in a similar manner in castrates of both sexes (p. 115). The *male hormone* is evidently the decisive factor in their differentiation since the presence of the testes causes involution of the ducts in males whereas the ovaries are not essential for their development in females. On the other hand the sex-type of the genital tubercle and the syrinx is conditioned by the ovaries. Both structures are normally developed in castrate males, for which male hormone is evidently not essential, whereas in castrate females also they closely approach the male condition in both form and size. It is the inhibitory action of the ovary, therefore, that determines the dimorphism of the syrinx and the genital tubercle.<sup>19</sup> These conclusions are confirmed by the fact that when isolated and cultured *in vitro* the Müllerian ducts, and the genital tubercle and syrinx, behave exactly as in castrate embryos; however, addition of *male hormone* to the culture medium causes involution of the Müllerian ducts, and *female hormone* prevents male differentiation of the tubercle and syrinx.

Significant differences thus appear in the reactions of the accessory sex structures in birds as compared with amphibians. In the

<sup>19</sup> This is true also of such striking sex characters as plumage type and spurs in adult fowl, whereas the head furnishings are under the control of the male hormone. There is, however, much variation in the relationships of secondary sex characters and gonad hormones in birds (Domig, 1939).

latter positive stimulation by the proper hormone is necessary to induce final sexual differentiation. In birds, the role of the sex hormones appears to be primarily *inhibitory*; in the absence of gonads Müllerian ducts develop normally in castrates of either sex and genital tubercle and syrinx spontaneously assume the male form. No positive stimulus is necessary, only release from the inhibitory influence of the opposing gonad. Thus, the castrate type in birds is not undifferentiated or intermediate in type, but is rather a mosaic in which certain characters are typically male, others typically female. Again, however, both hormones are essential for the realization of normal sex differentiation but with the female hormone having the major role with respect to the number of structures controlled.

*Mammals.* In mammals still another pattern appears in the relation of the accessory sex structures to the gonads and their hormones. Administration of pure steroid hormones demonstrates again that most of the genital primordia, regardless of sex constitution, are capable of reacting to the appropriate hormone, and if excessive dosages are avoided the responses are in most cases specific. To summarize, administration of male hormone does not significantly affect the development of male embryos except to accelerate the rate of differentiation; in females, on the other hand, it induces differentiation of male structures whereas female primordia are inhibited or fail to respond. In like manner, female hormones have a feminizing action on male embryos.

Again, it might be assumed from the results of hormone administration that the two hormones have comparable roles in normal differentiation. In reality, what is demonstrated is the capacities of the sex primordia to respond to hormones experimentally introduced; the true role of hormones in normal differentiation is disclosed only when the embryonic genital tract is required to develop in the absence of the gonads or other hormonal influences. Castration of mammalian embryos reveals that normal differentiation depends chiefly if not exclusively on the *male hormone*. Castrated embryos, regardless of genetic sex, develop female characters (Müllerian derivatives,

female sinus form and external genitalia, mammary glands) which are almost as well differentiated in castrates as in normal females (Figs. 2.26-2.28, and Table 2.2). Any possible influence of a maternal hormone in this result appears to be excluded (at least for the sex ducts and their derivatives) by studies of development *in vitro*. Culture of the isolated gonaducts results in persistence and development of the Müllerian ducts and involution of the Wolffian ducts, regardless of the sex of the donor embryo (pp. 117, 121) providing always that isolation is carried out before irreversible determination has occurred.

In mammalian embryos, then, the testes and the male hormone are all important for the normal differentiation of sex. Moreover, the role of the male hormone is a dual one; its presence is essential to insure retention and development of male parts and at the same time to prevent the differentiation of female structures, which are capable of developing autonomously, regardless of the presence or absence of female hormone. The latter apparently has no essential role in primary sex differentiation. At this point it should be recalled that such a conclusion had in fact been forecast much earlier on the basis of castration of the newborn rat (Wiesner, 1934, 1935; see Burns, 1938b). At birth morphogenesis of the genital structures of young rats is far advanced and profound modifications after castration are not to be expected; however, it was found that in castrate males a marked atrophy promptly appeared in such sex accessories as the seminal vesicles and external genitalia, suggesting that a hormonal influence had been removed, whereas in castrate females development proceeded more or less normally until the approach of puberty. These results were confirmed and extended by LaVelle (1951) in the newborn hamster. Wiesner (1934, 1935) proposed that sex differentiation might be explained on the basis of *one hormone*, the male, the presence or absence of which would account for the two types of development, an hypothesis now confirmed in a striking way by the results of castration during embryonic and fetal development.

The pre-eminent role of the male hormone

in mammalian sex differentiation stands in contrast with the situation in birds, in which the female hormone has the major role. The parallel with the well known difference in the sex-chromosome complex has been noted but this provides no immediate explanation and may be merely coincidence. On the other hand, another explanation may be found in the special physiologic conditions incidental to the evolution of intra-uterine development in mammals. A situation in which the female hormone has an active role in sex differentiation might present a serious difficulty with male embryos constantly exposed during development to the influence of the mother's hormones (the presence of considerable amounts of maternal estrogen during pregnancy is an established fact in many species (Price, 1947; Parkes, 1954). Elimination of the role of the female hormone coincident with the evolution of viviparity would then be advantageous. The problem of female development has apparently been met by a change in the status of the female sex primordia which, as amply shown by the results of castration and cultivation *in vitro*, do not require positive stimulation but develop autonomously unless inhibited by the male hormone.

### VIII. The Organization of the Sex Primordium and Its Role in the Differentiation of Sex

The role of hormones as specific conditioners of sexual differentiation is, however, only one aspect of the problem. Of far greater complexity, and fundamental to the selective character of the differentiation process, are the special attributes of the individual sex primordia which predetermine their reactions to the presence, or absence, of a particular hormone. Each primordium possesses a complex organization, not only as to sex type and morphologic character, but also with respect to such detailed physiologic properties as the timing of receptivity, the thresholds at which responses occur, and definite capacities for growth. It is obvious that specificity of hormone action does not exist independently of specificity of response. This organization of the primordium derives ultimately from the genotype of the

species, operating through the same processes of ontogeny that prescribe the special characteristics of other embryonic parts and systems; it is intrinsic as opposed to the conditioning activities of hormones and other modifying agencies which, with respect to the primordium, are external and secondary. Thus, sex primordia may be expected to show variations in behavior toward hormones which will be peculiar to and integrated with the patterns of development characteristic of particular groups or species.

#### A. CONSTITUTION AND THE MORPHOLOGIC REPRESENTATION OF SEX PRIMORDIA

It has been pointed out that even in the bisexual or undifferentiated period of development many variations are found among different species in the extent to which the structures of the recessive sex are represented morphologically, *i.e.*, are laid down in the form of discrete primordia. The absence or the deficient representation in one sex of certain heterotypic primordia may be normal for particular species, whose pattern of development thus places special limitations on sex reversal. In some amphibians reversal is difficult or impossible to induce experimentally because of the weak or transient representation of the recessive sex component in the gonad; there is no real transformation, merely a severely inhibited, or vestigial gonad. Certain accessory structures of the recessive sex may also tend to be abortive or imperfectly developed. This is the case for the Müllerian ducts in the males of various species. In young male opossums, for example, the Müllerian duct rarely completes its development to the point of union with the urinogenital sinus, or the connection if formed is quickly lost, so that the terminal segment of the duct is lacking. Consequently, it has never been possible to induce vaginal development in male opossums by treatment with female hormones, although the uterus and Fallopian tube are present and highly developed. Moreover, the tendency which leads to absence of this region of the duct in male embryos appears to be present also, but more weakly expressed, in the female. Although the terminal segment

of the duct is always present, it is susceptible to inhibition by male hormone while the tubo-uterine portion is never so affected (Burns, 1942b). Thus, specific morphologic defects which appear in experimental results can often be directly related to developmental peculiarities of the species in question and in final analysis are an expression of constitutional factors.

However, constitutional differences which control the morphologic representation of sex primordia do not as a rule involve simply the presence or the absence of a part, but more commonly have a quantitative expression, affecting the extent to which the structures are developed or the length of the period during which they are present and capable of responding. An example is found in the gonads of birds, in which there are marked lateral differences between right and left sides (p. 95). In consequence, the effects of hormones on the right and the left gonads may be different, not qualitatively but in degree. The left ovary, with its strongly developed cortical component (Fig. 2.12), is only moderately affected by doses of male hormone which almost completely transform the rudimentary right gonad (Willier, 1939). The morphologic differences between right and left testes are less marked, but consistently the germinal epithelium is better developed and tends to survive longer on the left side than on the right. Consequently, female hormone readily transforms a left testis into an ovotestis, and with stronger dosages into an almost normal ovary, but the right testis is but slightly affected except when the dosage is very large. It appears also from studies of the effects of graduated dosages that threshold differences for the two sides may be involved, thus a physiologic as well as a morphologic factor is introduced. It is not held that experimental failures or anomalies are always directly traceable to specific morphologic deficiencies; however, the frequency with which such correlations appear indicates the importance of underlying structural variations in modifying the responses of sex primordia under experimental conditions.

#### B. CONSTITUTIONAL FACTORS AND PHYSIOLOGIC DIFFERENCES IN THE ORGANIZATION OF SEX PRIMORDIA

In the foregoing cases obvious morphologic differences provide, at least in part, a basis for observed differences in the experimental behavior of sex primordia. It is unlikely that morphologic differences of this order exist without an underlying physiologic differentiation. On the other hand, under experimental conditions, physiologic differences often become apparent which have no visible morphologic expression, as in the inhibition of the vaginal canals of female opossums cited above. Certain accessory sex structures in birds exhibit lateral differences in sensitivity to hormones which are evidently a reflection of the general tendency to asymmetrical development in this group. In normal females only the left Müllerian duct develops into a functional oviduct; the right, although originally well developed, regresses at an early stage. After castration, however, both ducts develop equally (Fig. 2.25) as is also the case when the ducts are isolated *in vitro*. Involution of the right oviduct, then, is conditioned in some way by the ovaries and it has been shown that either the right or left ovary alone is effective (Wolff and Wolff, 1951). Evidently the ovaries exert an inhibitory action on the right oviduct which is not effective on the left. Presumably a threshold difference is involved.<sup>20</sup>

Other examples may be cited. The syrinx and the genital tubercle remain small, symmetrical, and essentially undifferentiated in females, but in males they become large and highly asymmetrical (Fig. 2.25). Unlike the paired structures previously dealt with, these organs are single and median in position and the asymmetry of the male form is due to unequal development of the lateral halves of the organs. It is well established in the case of each that the female hormone

<sup>20</sup> It seems unlikely that the inhibitory factor in this case is the female hormone since the introduction of estrogenic hormones into incubating eggs causes *persistence* of the right oviduct. However, the concentration or dosage may be a factor in this curious effect.

inhibits the male type of development (pp. 127, 131) which, on the other hand, develops spontaneously in both sexes after castration (Fig. 2.25) or after isolation *in vitro*, without hormonal conditioning. A difference in susceptibility to inhibition by the female hormone apparently masks the inherent difference in growth potential and the primary symmetry of the female structure is preserved.

The marked asymmetries of the genital system in birds thus appear to rest on lateral differences involving such physiologic characteristics as growth potentials and reaction thresholds. These in turn are apparently correlated with a more extensive asymmetry involving the whole organism. Lateral growth differentials are established in the blastoderm of chick embryos as early as the head-process stage. In testing the organ-forming potencies of regional pieces of the blastoderm it was found (Willier and Rawles, 1935; Rawles, 1936) that when corresponding pieces of the same size from right and left halves of the blastoderm are transplanted to the chorioallantoic membrane they consistently show marked differences in capacity for growth and self-differentiation, which are manifested both in the size attained by the graft (growth capacity) and in the quality of the histologic differentiation. Regardless of the particular tissues or organs dealt with, grafts from the left half of the blastoderm are consistently larger and better differentiated than those from the corresponding pieces of the right half. Lillie (1931) also postulated critical differences in growth rate and threshold to sex hormones on the two sides of the body in explaining the occurrence of "gynandromorphic" plumage in adult fowls and its distribution. He pointed out that the sharply defined difference in plumage on the two sides of the body is usually accompanied in gynandromorphs by gross bodily asymmetry (hemihypertrophy) favoring the left side. It would seem that lateral differences in the morphologic and physiologic properties of the sex primordia of birds are not peculiarities of sexual differentiation; rather they are an aspect of the general pattern of

somatic organization in this group. In the normal differentiation of sex as well as in experimental studies these differences are exploited by hormones whose effects serve merely to exaggerate or to obliterate tendencies inherent in the organization of the individual primordia.

#### C. INFLUENCE OF SEX GENOTYPE ON THE REACTIONS OF SEX PRIMORDIA

Another example of the way in which constitutional factors operate to modify or set limits to hormone action is seen in the influence of the *sex genotype* on the responses of sex primordia to hormones, as illustrated especially in young opossums (Burns, 1942b, 1956a). In comparing the effects of identical doses of the same hormone (whether male or female) in embryos of different sex, it was found in the case of many structures that the amount of growth induced was influenced by the sex of the individual. Under identical experimental conditions the effect of a male hormone on the growth of a particular male structure was always greater in male embryos than on the homologous structure in females, and *vice versa*. This result is well illustrated by the reactions of the genital tubercle or phallus in male and female littermates which received identical doses of testosterone propionate. The transformed phallus of the female cannot be distinguished anatomically or histologically from the male organ, except for a constant and considerable difference in size (Fig. 2.32). Such an effect was cited earlier in the case of the prostate (Fig. 2.29) and it occurs for various other male structures such as the vas deferens (Wolffian duct) and the epididymis (Fig. 2.24). After treatment with female hormone corresponding differences are observed in the response of female structures. The Müllerian ducts of male embryos hypertrophy and undergo a typical differentiation into oviduct and uterus; nevertheless, *in size* these organs do not approach those produced by the same dosage in females (Fig. 2.24). The same is true in the case of the hyperplastic reaction of the sinus epithelium and for other structures. Differences in size can be

detected at an early stage and increase throughout the period of treatment.

To account for the constancy of these differences it seems necessary to assume that sex constitution in some way conditions the reactivity of the primordia, placing certain limitations on rate of growth. When sex constitution and type of hormone administered are the same there is, in effect, a summation of the two factors, but when they are different a conflict occurs. It might seem more simple to suppose that the embryonic gonads and their hormones are involved in this result, rather than to assume a differential reactivity on the part of the sex primordia; hormones of the same type would in one instance reinforce each other whereas in the other case unlike hormones oppose each other. However, this simple hypothesis cannot be sustained. Although the presence of a hormone from the embryonic testis may be safely accepted, there is as yet no evidence in mammals that the ovary produces significant amounts of hormone at this period, thus no supplementary factor can be assumed in the case of females receiving female hormone. In the male, moreover, histologic studies reveal that the size differences observed are much too great to be accounted for by the secretory activity of the embryonic testis; for example, the difference in size between the male and the female prostate after treatment with male hormone (Fig. 2.29) is many times greater than the volume of the normal prostate, which may be taken as the measure of normal testis activity. The conclusive argument against participation of embryonic hormones in this phenomenon has come, however, from examination of the embryonic testes of experimental animals (Burns, 1956a). There is a great reduction in the size of the testis (and the ovary as well) and histologic study shows complete suppression of the interstitial tissue, the intertubular spaces being filled with a dense, nonstaining connective tissue of mucoid type. In contrast, the normal testis of the same age has a rich interstitium which is well developed as early as the 10th day of pouch life (Fig. 2.17A). Evidence to be summarized later points strongly to the embryonic interstitial tissue as the source of the testis hormone, and in

the absence of this tissue it does not seem that the testis can be a factor in the result.

### **IX. The Time Factor in the Responses of Sex Primordia: Receptivity and "Critical Periods"**

Of special importance is the factor of developmental age as it relates to the appearance of receptivity and the timing of determinative changes in sex primordia. This becomes apparent when the reactivity of a primordium to sex hormones, or its capacity for independent differentiation after isolation, is tested at successive stages of development. Typical studies of the second type are the experimental analyses of the appearance of sex-specific organization in the genital ridge of chick embryos (Willier, 1933) and in the differentiating gonads of the rat (Torrey, 1950; see pp. 103, 104). Such studies show that the organization of embryonic gonads with respect to sex type and capacity for self-differentiation is acquired gradually, leading step by step to changes which are stable and irreversible. Such transitions coincide in some cases with distinct morphologic events. In Willier's study of chick gonads fixation of sex-type, with capacity for autonomous differentiation, coincides with the appearance of a distinct germinal epithelium on the genital ridge. In rat gonads (Torrey) the sexes differ greatly in this respect; differentiation of prospective testes becomes an autonomous process from the first laying down of the medullary blastema, whereas the ovary has but little capacity for self-differentiation until much later, after the appearance of a distinct cortical zone.

The fact that at certain stages of development changes of an irreversible nature can be demonstrated has led to the recognition of so-called "critical periods," during which rather abrupt transitions occur from a state of lability to one of complete autonomy. Thereafter, hormones or other extraneous factors no longer have decisive effects. Such stages have been demonstrated for various types of sex primordia and are often narrowly limited in time. In chick embryos continued development of the Müllerian ducts, or their involution, depends normally on the type of gonad present, but at a cer-



tain stage their fate can be permanently conditioned by hormones administered experimentally (Wolff, 1938; Stoll, 1948). In male embryos involution of the ducts is prevented by administration of female hormone at the proper stage (p. 112), and once "stabilized" in this manner their subsequent development is assured without further treatment. Male hormones administered before this stage induce involution of the ducts in the living embryo or *in vitro*, but beyond this point have no effect.

The genital tubercle of the female duck shows a critical stage in relation to the embryonic ovaries during the 9th day of incubation (Wolff and Wolff, 1952b). When isolated *in vitro* before this stage the tubercle always develops the male form, which is also the condition found in castrated embryos. Isolation after the 9th day, however, results always in a structure of female type. About the 9th day of development, then, its future character becomes fixed after which differentiation proceeds without further need of hormonal conditioning. Similar results were obtained in the case of the syrinx. If isolated before the stage of final determination the sex type of both primordia can be readily controlled *in vitro* by addition of hormones to the medium.

The Wolffian ducts of mammalian embryos behave similarly. In this instance the male hormone is necessary at a certain stage to insure retention of the ducts. Castration of male rabbit embryos before the 22nd day is followed by involution but later castration has little effect; changes of an irreversible nature have occurred which insure continuation of development regardless of hormonal conditioning. A critical period of brief duration also exists for the prostate glands of young opossums, involving the response to both types of sex hormone. Estrogens permanently suppress prostate development in males if a single dose is administered just before the stage when the buds should appear. Male hormones, on the other hand, induce prostatic glands in females at this stage which thereafter continue to develop without further treatment. The effects of castration on the prostate are like those described for the Wolffian ducts. In rabbit embryos the critical period falls

from the 22nd to the 23rd day of gestation after which the operation has but slight effect (Table 2.2).

It appears from much evidence of this kind that sex primordia typically pass through developmental phases which are crucial with respect to the origin, the survival or the future mode of differentiation of the structure in question. At such stages, and for brief periods, formative or suppressive, trophic or involutionary, responses are readily induced by hormones. However, the physiologic status of the primordium itself prescribes the specific quality of the response and the timing as well.

### X. Specificity of Hormone Action and the Significance of Paradoxical Effects

Perhaps the objection most frequently urged against steroid hormones as specific agents in sexual differentiation is the common occurrence of paradoxical effects, in which a hormone of one type stimulates the differentiation of structures of the other sex, sometimes in a striking manner. Such responses have been encountered in all major groups thus far investigated, and practically every type of sex character may be involved. The frequency with which this phenomenon is associated with high dosages has been noted, with emphasis on the fact that *in low concentrations* the effects are usually sex specific. Some apparent exceptions to this general rule may, indeed, be due to difficulty in defining a low dose in particular cases in view of the efficiency of extremely low concentrations in certain species (*e.g.*, Mintz, 1948). Specificity of action obviously implies that male hormones stimulate development of male characters in embryos of either sex, whereas female primordia are inhibited or give no positive response; in like manner, female hormones should induce differentiation of female primordia while inhibiting the development of male structures. Convincing examples of specific action in this sense are found in the complete and even functional transformations obtained in various amphibian species with low concentrations of hormones (Table 2.1); in the maintenance of normal differentiation after castration by treatment

with a crystalline hormone; and in the manner in which many accessory sex structures or their primordia respond to the appropriate hormone, both *in vivo* and *in vitro*. It should be emphasized further that paradoxical effects seldom appear to the exclusion of normal responses, but usually as accompanying phenomena. For example, large doses of testosterone propionate produce strong hypertrophy of the entire male genital system in opossum embryos as expected; however, they also cause hypertrophy of the Müllerian duct derivatives, a response that disappears at low dosages although the effect on male structures remains.

In the interpretation of paradoxical effects the problem of direct *vs.* indirect action arises. It may be argued tentatively that *in sufficient concentration* hormones of either type stimulate the primordia of the other sex by direct action; both sets of primordia are capable of responding but at different thresholds, those of heterotypic structures being very high. Such a situation would permit selective action at ordinary or "physiologic" levels and at the same time account for the appearance of paradoxical effects at higher concentrations. As a matter of fact, the dosages which elicit paradoxical responses are as a rule so far above physiologic levels as to have doubtful significance for normal differentiation. Evidence favoring the thesis of direct action has been cited and in one case at least a typical paradoxical effect has been produced *in vitro*. Large doses of testosterone propionate have a strong feminizing (*i.e.*, inhibitory) action on the syrinx of the duck *in vitro* (Wolff and Wolff, 1952a). However, the presumption that the paradoxical action must have been exerted directly does not establish its nature. The high concentration of male hormone obviously has an adverse effect, resembling the inhibitory effect of the female hormone, but the inhibition is possibly of a general nature rather than specific. First attempts to culture the syrinx on a simple synthetic medium also resulted in atypical differentiation (Wolff, Haffen and Wolff, 1953) due apparently to nutritive deficiencies. High concentrations of hormones *in vitro* may only create general

conditions unfavorable for normal growth and differentiation.

On the other hand, paradoxical effects are certainly in some cases not mediated directly but are of secondary origin. The feminization of the testes that occurs in certain amphibians after treatment with male hormones (p. 94; for a summary see Gallien, 1955) is an example. An early disturbance of mesonephric development interferes subsequently with differentiation of the medullary sex cords, thus preventing testicular development. After metamorphosis, when the hormone is withdrawn, a certain recovery occurs and development is resumed, but in the virtual absence of the medullary component only the cortical rudiment develops. It should be noted, however, that during the hormone phase of this experiment there is inhibition of the cortex as well as suppression of the medulla, and it is only after the male hormone is withdrawn that development of the cortex is resumed. Although the paradoxical effect on the medulla is pronounced it is indirect, and it does not occur alone but in conjunction with a partial atresia of the cortex. Thus the picture is more complicated than first appears.

On the other hand, the correlation between the appearance of paradoxical effects and the use of high dosages suggests other possibilities as to the manner in which such effects are mediated. It is a familiar fact in endocrine physiology that prolonged treatment with sex hormones disturbs the normal endocrine balances and may influence the activity of other glands. It is possible that certain paradoxical effects may originate in this way. As yet there is no direct evidence of this in embryonic organisms but it is well known that under abnormal or pathologic conditions both the gonads and the adrenal glands of adult animals are capable of producing the hormones of the other sex. This is the case for certain tumors of the gonads and adrenal cortex, and it is characteristic of the adrenal hyperplasias which produce the adrenogenital syndrome in fetal and postnatal life. It is also well established that under abnormal physiologic conditions ovaries may produce considerable amounts of androgen (*cf.* Hill,

1937a, b; Deanesly, 1938; for further discussion see Ponse, 1948). A striking case of adrenal disturbance induced by a sex hormone appears in frog tadpoles completely masculinized by large doses of estradiol. Histologically, the change takes the form of a massive hyperplasia of the adrenal cortical or interrenal tissue (Padoa, 1938, 1942; Witschi, 1953; Segal, 1953) which may attain 10 times the normal volume. In this remarkable case, however, the masculinization of the ovaries is not caused by the adrenal hyperplasia, because in hypophysectomized tadpoles the hyperplasia does not occur but the paradoxical masculinizing effect still persists. Nevertheless, when excessive doses of sex hormones can induce glandular disturbances of this order, the possibility remains that they may be only secondarily involved in the appearance of paradoxical effects.<sup>21</sup>

Perhaps the simplest explanation of the paradoxical effects of high dosages lies, however, in the possibility that, when present in excess, a hormone may be transformed in the organism into one of opposite type. In this event two hormones are in fact acting simultaneously and the specificity of the administered substance is not in question. This possibility was first suggested by findings in the adults of several mammalian species, including man. Treatment with large amounts of testosterone may be followed by excretion of considerable quantities of estrogen in the urine, which disappears when the male hormone is withdrawn (for the older literature see Burrows 1949, Ch. VI). This may occur in normal males, in castrates or in eunuchoid types. In female subjects the estrogen thus produced is sufficient to stimulate female characters or functions, e.g., a marked hyperplasia of the vaginal epithelium appears. Without the knowledge that estrogen is being produced this would be regarded as a typical paradoxical effect. Conversion of testosterone to estrone or estradiol also

takes place in ovariectomized and adrenalectomized women (West, Damast, Sarro and Pearson, 1956). It is evident that neither gonads nor adrenals are necessary for such conversions, which may even occur *in vitro* (Baggett, Engel, Savard and Dorfman, 1956; Wotiz, Davis, Lemon and Gut, 1956). Finally, it has been established that the injected male hormone is the actual source of the estrogen by the use of testosterone labeled with C<sup>14</sup> (Baggett, Engel, Savard and Dorfman, 1956; Wotiz, Davis, Lemon and Gut, 1956; Heard, Jellinek and O'Donnell, 1955; for a recent review of this subject see Dorfman, 1957). Although it may be technically difficult to demonstrate such conversions in embryonic organisms, there are no grounds for supposing that they cannot occur.

#### XI. Time of Origin and the Source of Gonad Hormones

Evidence that the embryonic gonads begin to produce their hormones early in the course of sexual differentiation comes from many sources. In the more strongly modified freemartins, conditions indicate that the hormone of the male twin must have been active at an early stage. The ovaries of the female are severely inhibited with almost complete suppression of cortical differentiation (Willier, 1921). Lillie (1917) suggested that in such cases the first action of the male hormone might be to produce, in effect, a "castration" of the female twin by suppression of the ovarian cortex. It now appears from the results of actual castration experiments that this point is probably not significant as there is nothing to indicate that the ovary is active endocrinologically at such an early stage (Bascom, 1923).

In amphibians, either after parabiosis or transplantation of the gonad primordium, changes in the gonads can be detected very early in relation to the onset of sex differentiation, and in some circumstances reversal occurs by direct differentiation as a gonad of opposite sex. The gonads involved are as a rule widely separated and the hormonal nature of the transforming agent in these cases is beyond question. Similar indications are found in birds. Embry-

<sup>21</sup> For fuller discussions of various forms of paradoxical effects and their interpretations see Gallien (1941, 1950, 1955), Wolff (1947), Ponse (1948), Padoa (1950), Jost (1948a) and Burns (1949, 1955b).

onic ovaries grafted into the coelomic cavity induce cortical differentiation in the testes of male hosts at a very early stage, and during the same period testis grafts inhibit the differentiation of the Müllerian ducts. A similar effect is observed when histologically undifferentiated gonads of duck embryos are cultured *in vitro* in close contact (Wolff and Haffen, 1952b). When ovaries and testes are thus associated the latter exhibit typical reversal changes from the very beginning of sexual differentiation.

In mammals the activity of the testis hormone in the early stages of sex differen-

tiation is revealed by the promptness with which castration effects appear. In the absence of the testes, changes in certain accessory sex structures are evident as soon as sexual differentiation can be observed. In the case of the prostate the hormone is actually necessary for the appearance of the primary buds. Conversely, implantation of an embryonic testis into a female rabbit embryo inhibits the Müllerian ducts and initiates development of male accessory structures (Fig. 2.35; for a more detailed summary see Willier, 1955).

The source of the hormones produced by

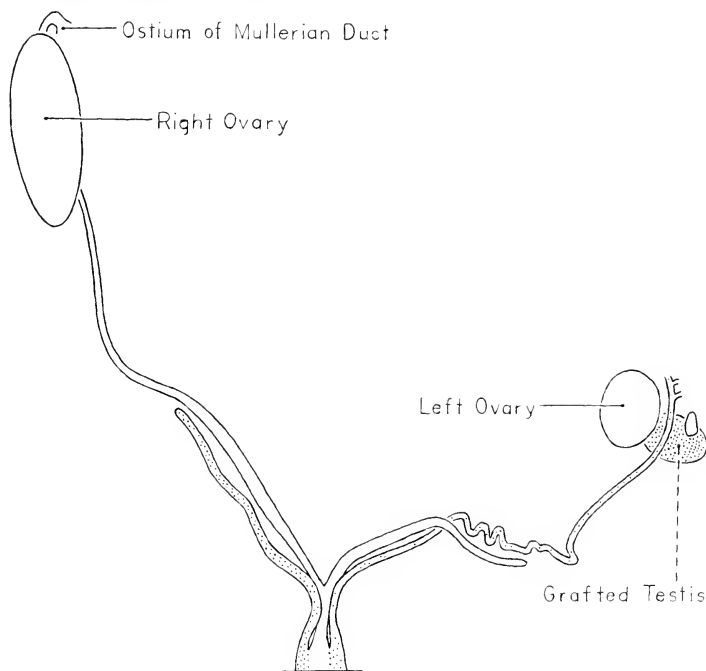

FIG. 2.35. Localized effects of an embryonic testis grafted to the broad ligament of a female rabbit embryo (Jost, 1947b). The inhibitory effect of the grafted testis has caused a great reduction in the size of the host ovary and has suppressed the Müllerian duct (unshaded) in the vicinity of the graft. These structures are normal on the opposite side. Conversely, the testis has induced complete retention of the Wolffian duct and epididymis (stippled) on the side of the graft and a partial retention on the other side. The influence of the graft is strongest in its immediate vicinity and beyond a certain distance disappears, indicating that the hormone spreads locally by diffusion rather than through the circulation. The results also suggest that the stimulatory action on the male structures is stronger than the inhibitory effect on the Müllerian duct, since it extends further. Such a situation probably results from threshold differences in reactivity of the two end-organs to the testis hormone.

the embryonic gonads is a matter which can be discussed with some assurance only in the case of the mammalian testis. In the testes of adult mammals the interstitial tissue has long been recognized as the source of the male hormone and, as was pointed out in the beginning, the marked development of this tissue in the testes of pig embryos led to the first suggestion that a hormone might be involved in sexual differentiation (Bouin and Ancel, 1903). In connection with the freemartin studies, an examination was made of the gonads of normal calf embryos and fetuses (Bascom, 1923) which pointed to the well developed interstitial cells as the probable source of the male hormone. This provided a plausible explanation of the invariable dominance of the male twin, because in fetal ovaries no indication of internal secretion could be found until relatively late in gestation; in the testis, on the contrary, interstitial tissue was seen in increasing amounts from practically the beginning of sex differentiation.

It is unnecessary to multiply cases in which the presence of interstitial tissue in the embryonic testis coincides with indications of hormone activity. On the other hand, instances in which a reduction in testis activity (as evidenced by the condition of the sex accessories) can be correlated with the status of the interstitial tissue are pertinent. Decapitation of rabbit embryos (Jost, 1951a) is followed by definite retardation in the development of certain male accessory structures, although the growth of the embryo as a whole is normal. Examination of the testes in these specimens showed a reduction in size and in the number of interstitial cells; whether there was also cytologic abnormality has not been ascertained. The defects of the sex accessories in the decapitated fetuses resembled those which appear after incomplete or unilateral castration. Structures near the defective testes (epididymides, vasa deferentia) were virtually normal but more distant structures (sinus derivatives, external genitalia) showed failures of development comparable to those produced by complete castration. Inadequacy of the testes to maintain normal development in these cases is appar-

ently due to a quantitative deficiency of the interstitial tissue and the male hormone.

A similar reduction of the interstitial tissue occurs in decapitated rat fetuses (Wells, 1950) and in this instance cytologic changes in the interstitial cells were also seen. In this species, however, no clear effects were observed on the accessory sex organs, as is also the case in fetal mice hypophysectomized by irradiation (Raynaud and Frilley, 1947; Raynaud, 1950). Negative findings in these cases may be attributable to species differences as to the stage at which the interstitial tissue becomes active; however, it is more probable that the different result is due simply to the longer period of observation in the rabbit, allowing more time for the deficiencies to appear.<sup>22</sup>

Also pertinent in this connection is the behavior of the interstitial tissue of the embryonic rat testis transplanted between the lobules of the seminal vesicle of a castrate adult; the interstitium of the grafted testis undergoes a considerably hypertrophy and the epithelium of the host's seminal vesicle gives a corresponding response (Jost, 1951b). But when the host is also hypophysectomized such grafts are deficient in interstitial cells and there is little or no response by the seminal vesicle (Jost and Colonge, 1949). The correlation between the state of development of the interstitial cells and the evidences of hormonal activity in these cases is direct and striking (for a recent review of this subject see Jost, 1957).

## **XII. A Comparison of the Effects of Embryonic and Adult Hormones in Sex Differentiation**

A problem has long existed as to whether the hormones or hormone-like substances produced by the embryonic gonads are essentially similar in character to adult sex hormones. When the effects of the two types of hormone on the development of embryonic sex primordia are studied under comparable conditions the resemblances are in

<sup>22</sup>It should be noted that treatment with gonadotrophins prevents the reduction in the interstitial tissue after decapitation, and may even produce hypertrophy of the interstitial cells (Wells 1950, Jost, 1951a). In one instance also a graft of the fetal hypophysis had the same effect (Jost).

many cases extremely close; moreover, some of the apparent discrepancies have since been found to be due not to fundamental differences in the two types of hormone but to differences in experimental conditions as regards such factors as timing and dosage. The most important objections to steroid hormones of adult type as controllers of sex differentiation have been noted previously in various connections. However, a brief recapitulation is in order: they are (1) the frequent occurrence of paradoxical effects; (2) the failure of male hormones to inhibit effectively the Müllerian ducts of mammalian embryos; and (3) their failure in nearly all cases to have significant effects on the differentiation of mammalian gonads. The first objection has been dealt with (p. 141) and will not be discussed further. In the other cases the failure is not absolute; moreover, it is confined to a single group, the mammals, and is not of general application. To an extent, group or species differences may be involved. In the hedgehog, for example, the funnel region of the oviduct is inhibited by male hormone (Mombaerts, 1944), and in female opossums the vaginal portion is suppressed on one or both sides in about 50 per cent of all individuals (p. 114). Furthermore, in mouse and rabbit embryos male hormone prevents the union of the posterior ends of the Müllerian ducts to form the vaginal canal (Raynaud, 1942) and *corpus uteri* (Jost, 1947a). These partial effects in themselves require explanation. Failure of steroid hormones to reproduce more fully the effects of the embryonic hormone may lie, at least in part, in experimental conditions other than the type of hormone. On the other hand it is possible, as suggested by Jost (1953, 1955), that in mammals a special substance is required for the inhibition of the Müllerian ducts other than the ordinary testis hormone.

The failure of steroid hormones to modify the gonads of placental mammals (even when the accessory sex structures are profoundly transformed) is in marked contrast with the striking results obtained in many lower vertebrates and in the opossum. It is also at variance with the strong modifications usually found in freemartin gonads, and this has often been cited as proof that

different types of hormone are involved. However, the freemartin is still almost unique among mammals as an example of gonad transformation induced by another embryonic gonad, and may yet prove to be a special case of a type peculiar to the bovine family.<sup>23</sup> The possibility must be considered that in placental mammals gonad differentiation (as opposed to the differentiation of the accessory sex structures) has come to be under direct genotypic control; nevertheless, the demonstration, after many earlier failures, of a thoroughgoing transformation of the testis in the opossum suggests that certain essential experimental conditions have perhaps not been fully realized. In any case, it may be a difficult matter to determine whether the refractoriness of mammalian gonads to steroid hormones is indeed due to a fundamental difference in the character of the hormones themselves or to a change in the status of the embryonic gonads affecting their reactivity to hormones.

In many other situations it appears that embryonic and adult sex hormones are interchangeable without observable differences in the results. Testosterone propionate or methyl-testosterone, administered to castrated rabbit embryos at the time of operation, prevent the usual castration changes in all male structures, in this respect fully replacing the embryonic testis (Jost, 1947b, 1950, 1953), although they do not inhibit the Müllerian ducts. A similar effect of tes-

<sup>23</sup> There is, in fact, a notable scarcity of freemartins in a strict sense in other groups in which, on the grounds of placental fusion, the phenomenon might be expected to occur at least occasionally. For the literature on scattered cases interpreted as freemartins, see Willier (1939) and Witschi (1939); and for a case (the marmoset, Wislocki) in which no freemartin effect was found although the essential conditions seemed to be present, see Witschi (1939). It is possible that the presence of the hormone is not the only factor to be considered; lack of reactivity on the part of the gonad may be the principal factor and one which may vary in different groups, correlated perhaps with the presence of maternal or placental estrogens during pregnancy. There is still a surprising lack of information for many groups; for example, the freemartin condition in sheep (at least as regards sterility) may occur more frequently than has been supposed (see Stormont, Weir and Lane, 1953).

tosterone propionate in maintaining the male accessory glands has been shown in castrated rat embryos (Wells, 1950; Wells and Frailek, 1951). In opossum and other mammalian embryos synthetic androgens readily induce in females prostatic glands which are histologically indistinguishable from those of normal males although the latter are known to be conditioned in certain species by the hormone of the embryonic testes. Also, with proper timing, synthetic androgens induce involution of chick Müllerian ducts, either *in vivo* or *in vitro*, in a manner not histologically distinguishable from the effects of the embryonic testis (p. 114). Examples of this kind could be multiplied. Furthermore, the female hormone estradiol controls the sex type of various avian sex primordia, even when administered *in vitro*, closely simulating the normal action of the embryonic ovary. When it is added to the culture medium, testes are transformed into ootestes in the same fashion as when cultured in association with an embryonic ovary (Wolff and Haffen, 1952b), and it produces a typical female syrinx or genital tubercle *in vitro* regardless of the sex of the donor embryo (Wolff and Wolff, 1952a; Wolff, 1953a).

Conversely, an example of an embryonic hormone substituting for an adult sex hormone is seen in the effect of a graft of the embryonic testis on the epithelium of the seminal vesicle in an adult castrate rat (Jost, 1948b, 1953; Jost and Colonge, 1949). Within a few days the vesicle epithelium in the vicinity of the graft is completely restored. Although the interstitial tissue of the grafted testis is somewhat hypertrophied under the influence of the host's hypophysis, it is improbable that a radical change in the character of the testicular secretion could be induced so quickly. That the hormone of the graft must be attributed to interstitial cells which cytologically are like those of the adult testis is also significant. It should be noted further that both estrogens and androgens (which can be detected by standard methods of assaying adult sex hormones) have been extracted from chick embryos in the latter half of the incubation period (Leroy, 1948) and from fetal mammalian gonads as well (*e.g.*, Cole, Hart, Ly-

ons and Catchpole, 1933). If special embryonic hormones are necessary for the control of sex differentiation, it would seem that hormones of adult type are also being produced during the same period.

Many minor inconsistencies can be pointed out in comparing the effects of the two types of hormone, but experimental conditions are usually too dissimilar to justify such detailed comparisons. It is noteworthy that the most "normal" results from the use of steroid hormones have been obtained under conditions which most closely approach the ideal, as when larval amphibians absorb the hormone continuously but in low concentration from the surrounding water. In many such experiments involving many species (Table 2.1) all individuals develop in accordance with the type of hormone used, and without obvious histologic abnormalities. Under similar conditions, however, if the concentration is increased, all gonads become intersexual and very strong doses may actually produce effects exactly opposite to those obtained at very low levels (p. 94).

It is nevertheless too simple to suppose that all difficulties may be avoided simply by empirically arriving at the proper dose. What constitutes the optimal dose is not easy to determine from one species to another for, regardless of absolute concentration, the hormone level in the internal environment of the experimental organism may be greatly affected by such factors as the rates of absorption, utilization, and inactivation. These are factors which vary widely with different hormone preparations, different methods of administration, and also no doubt from one organism to another. In the second place, it is difficult or impossible to adjust the dosage accurately and flexibly from stage to stage, to correspond with the changing conditions of development and the state of the reacting structures; however, a continuing equilibrium is doubtless more nearly approached when doses are relatively low and the hormone enters continuously through the gills or by infusion from a graft. In comparison with normal development experimental conditions must always be arbitrary and inflexible; a dose which permits a normal response

in the case of one structure may be quite discordant for others, resulting in serious disharmonies or even in paradoxical reactions. Nevertheless, much can be learned analytically of the processes involved in sex differentiation without requiring perfectly integrated results.

### XIII. Embryonic Hormones and Inductor Substances

According to generally accepted theory, the normal differentiation of the gonads is the result of an antagonistic interaction between the cortical and medullary components, in which one element (as prescribed by sex genotype) gradually becomes predominant while the other retrogresses. It has been previously emphasized that in experimental sex transformation no new principles or processes are involved; the normal mechanism is simply set in reverse. The transformation process as it appears at various stages presents essentially the same histologic picture, whether the impulse to reversal comes from a developing gonad of opposite sex or from an administered hormone. It has been shown further that steroid hormones are capable in many cases of redirecting the differentiation process from its inception, leaving but slight histologic traces of reversal. Thus the processes of sex differentiation in the gonads are amenable to control by hormones at least over a considerable range of the developmental period.

The question then arises as to the manner in which the antagonistic interactions between cortex and medulla are mediated in normal development, and the nature and relationships of the physiologic agents involved. On this subject differences of opinion have long existed. The well known theory of Witschi<sup>2</sup> postulates special inductor substances elaborated by the cortical and medullary tissues. Because the special sphere of the inductor substances is presumed to be the regulation of gonad differentiation, their field of action is thus topographically restricted; when at later stages the gonads begin to exercise control over the developing accessory sex structures, frequently over considerable distances, the action of embryonic hormones is presumed. However, since steroid hormones also may influence, or

even completely control, the mechanism of gonad differentiation, it is important to know whether such control is exerted secondarily, *i.e.*, by regulating the inductor systems, or whether hormones are capable of playing the role of inductors. It must be remembered that the inductor substances have not as yet been isolated or directly identified; their existence and their character are postulated from the nature of the effects attributed to them. Consequently, this problem can only be approached indirectly by comparing the effects of sex hormones under as many conditions as possible with those ascribed to the inductor substances.

Although the activities of the inductor substances are ordinarily confined to the gonads, it is held that under favorable conditions their influence may extend somewhat further, but only within a limited range. This view was originally based on observations in certain parabiosis experiments (Witschi, 1932) and involves the manner in which inductor substances are supposedly transported. In parabiotic pairs of frogs, so closely united that the gonads lie within in a common body cavity, gonads of different sex do not influence each other significantly except when they are *in contact or in very close proximity*. The action of the inductor substances, that is to say the intensity of their effects, seems to be roughly proportional to the distance between the interacting gonads (Fig. 2.2B). This observation suggested that the inductor substance is transmitted only by diffusion through the tissues, the concentration declining steadily with distance from the point of origin. Failure to be effective at greater distances presumably indicates that the agent is not distributed through the blood in the manner of a hormone. This, however, may mean only that in early stages of development the humoral substances, whatever their nature, are not produced in sufficient quantity to reach or maintain an adequate level in the bloodstream. In parabiotic salamanders, on the other hand, typical sex reversal also occurs, although the interacting gonads as a rule are widely separated (Fig. 2.2A). In this case the inducing agent must be blood-borne; nevertheless, the changes in the re-



versing gonads occur at the same time and are of the same histologic character as those attributed to inductor action. Evidently the effects of gonads acting from a distance through the agency of blood-borne hormones are not distinguishable from those attributed to inductor substances when the interacting gonads are in close juxtaposition.

Furthermore, in other experimental situations where hormones are almost certainly involved, effects of a strongly localized character can be observed under proper conditions. When sexually differentiated gonads are grafted into the coelomic cavity of chick embryos (Wolff, 1946) ovaries have a transforming effect on the testes of male hosts which varies according to their relative proximity; and at the same stage of development testis grafts modify the adjacent gonaducts. A similar response appears when well differentiated larval gonads of *Ambystoma* are transplanted into the body cavity of another larva (Fig. 2.3) and in this case the effects are reciprocal. Also, after unilateral castration of male rabbit embryos (Jost, 1953), the sex accessories on the two sides of the body may show distinct differences in reaction. On the unoperated side normal differentiation of the sex ducts occurs, but on the operated side the Müllerian ducts are not completely inhibited and the Wolffian ducts are only partially preserved (*cf.* also Price and Pannabecker, 1956). It would seem that the remaining testis produces enough hormone to insure normal development of nearby structures, but at this early stage its output is insufficient to maintain proper development of structures at greater distances. A comparable result was obtained when an embryonic testis was implanted in a female embryo in close proximity to one ovary of the host (Jost, 1947b, 1953). The ovary on the side of the grafted testis was inhibited and atrophic whereas the other was normal (Fig. 2.35), and duct development followed different patterns on the two sides. On the side of the testis graft the Wolffian duct and epididymis persisted and developed but the Müllerian duct was suppressed in the vicinity of the graft. On the side of the normal ovary these relationships were reversed.

Evidently the pattern of development is determined by proximity to the grafted testis.

The same situation as regards the differentiation of the sex ducts and accessory structures is often encountered in so-called "lateral gynandromorphs" which occur sporadically in many mammals. In such cases, where embryonic hormones are clearly involved, the localized aspect of their action often resembles closely the postulated effects of inductor substances. It is interesting to compare the results of the experiments cited above with conditions found in a type of lateral gynandromorphism of doubtful etiology which occurs in a certain genetic strain of mice (Hollander, Gowen and Stadler, 1956). These gynandromorphs have an ovary on one side and a testis on the other, but without relation to laterality. Typically both gonads are small and underdeveloped, with the testes as a rule more severely affected. It is the condition of the accessory sex structures in these cases that is of special interest. On the side of the testis, development of the gonaducts without exception follows the male pattern (24 cases), a vas deferens and epididymis are present, and Müllerian duct derivatives are lacking (Fig. 2.36). This condition corresponds exactly to the role of the testis as the conditioner of male duct development and the inhibitor of the Müllerian duct, as revealed by the results of castration and culture *in vitro*. The development of the seminal vesicles is variable and the external genitalia, although usually underdeveloped, are nearly always of male type. These conditions in turn can be correlated with the size of the testis and the factor of distance from a gonad which is probably subnormal in its secretory activity. On the side of the ovary the opposite picture prevails; the Müllerian derivatives are always present, although variable in size, whereas the male accessories are either imperfectly developed or in most cases altogether lacking. A similar condition has recently been reported in a gynandromorphic hamster (Kirkman, 1958). It may be noted that lateral differences of this kind are not infrequently met with in certain human intersexes (Jost, 1958; Wilkins, 1950).

Evidence from other types of experi-

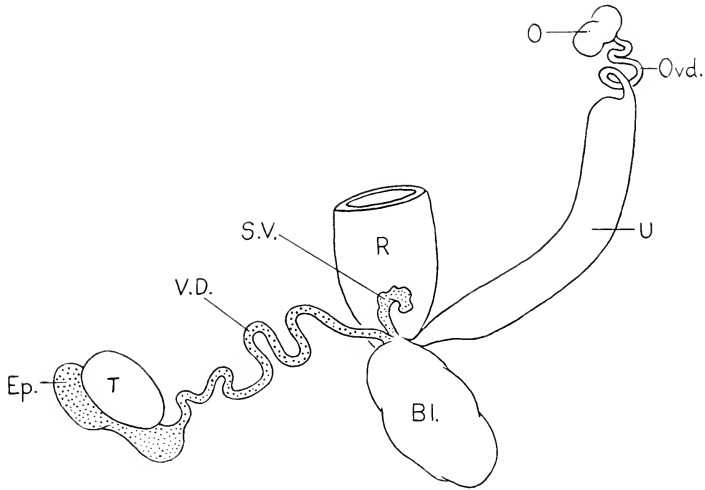

FIG. 236. Composite drawing illustrating the condition of the genital systems in a group of "gynandromorphic" mice, which have an ovary on one side of the body and a testis on the other, after Hollander, Gowen and Stadler (1956). On the side of the testis (which as a rule was partially or entirely descended and is shown as dissected out) a complete male duct system with seminal vesicle is present; the female genital tract is absent on this side. On the side of the ovary a complete female genital tract is found, although it varied greatly in size in different cases. On this side the male duct system was usually absent, but appeared in whole or in part in about one third of all cases. Compare with conditions induced by a unilateral testis graft shown in Figure 235. Abbreviations: Bl., bladder; Ep., epididymis; O, ovary; Ovd., oviduct; R, rectum; S.V., seminal vesicle; T, testis; U, uterus; V.D., vas deferens.

bears on this point. When the pituitary is absent the normal secretory activity of the embryonic testis may be materially reduced. In male rabbit fetuses deprived of their hypophyses by decapitation, although the testes are present, an apparent decrease in endocrine activity has local effects which resemble those of castration (Jost, 1951a, 1953). In their lowered state of activity, the influence of the testes on the accessory sex structures is graduated according to distance. Structures near the gonads, such as the vas deferens and epididymis, are normally developed but the more distant sinus derivatives and external genitalia are of female (*i.e.*, castrate) type. Here again a level of activity adequate to maintain normal development of nearby structures is ineffective at greater distances, and the result is not compatible with the view that the hormone is distributed only through the blood stream.

Approaching the question from yet another direction, a clear demonstration of local action by a hormone appears in an experiment cited previously, in which an embryonic testis is engrafted between the lobules of the seminal vesicle of a castrate host; there is complete cytologic recovery of the atrophic epithelium in lobules contiguous with the graft, but the effect diminishes rapidly with distance and soon disappears. Greenwood and Blyth (1935) have also described a sharply circumscribed effect on the feathers of capons. A very small dose of female hormone injected subcutaneously changes the pigmentation of growing feathers at the site of injection, but beyond a very short distance it has no effect. On the other hand, after local implantation of hormone pellets, both localized and more distant effects may be registered at the same time, indicating that both modes of distribution are simultaneously effective (*cf.*

Robson, 1951; Grayhack, 1958). A survey of a considerable literature on the local action of sex hormones (Speert, 1948) indicates that, with due consideration for such factors as vascularity and method of application, dual action in the above sense is chiefly a matter of dosage. Larger doses may have strong local effects accompanied, however, by a definite "systemic" action on distant structures. With small doses only local effects appear. Finally, it should be emphasized that localized activity has been demonstrated under suitable conditions in the case of many other endocrine glands and their hormones.<sup>24</sup>

Thus numerous parallels and resemblances may be adduced with respect to the behavior of the hypothetical inductor substances and the local effects of sex hormones. On the basis of their histologic effects on gonad differentiation, their mode of distribution and range of action, and the period during which they operate, it seems that no clear or final distinctions can be drawn. Although theoretically the possibility cannot be excluded that hormones act indirectly on gonad differentiation by controlling the existing inductor systems, there are obvious advantages in postulating a single humoral agency; theory is simplified and hypothetical substances are replaced by known entities (for further discussions of this problem see Wolff, 1947; Jost, 1948a, 1953, 1955; Ponce, 1949; Burns, 1949, 1955b; Witschi, 1950, 1957).

#### XIV. References

ACKART, R. J. AND LEAVY, S. 1939. Experimental reversal of sex in salamanders by the injection of estrone. *Proc. Soc. Exper. Biol. & Med.*, **42**, 720-724.

ANDERSON, D., BILLINGHAM, R. E., LAMPSON, G. H., AND MEDAWAR, P. B. 1951. The use of skin grafting to distinguish between monozygotic and dizygotic twins in cattle. *Heredity*, **5**, 379-397.

ANGEVINE, D. M. 1938. Pathologic anatomy of hypophysis and adrenals in anencephaly. *Arch. Path.*, **26**, 507-518.

<sup>24</sup> See Etkin (1936) Etkin and Huth (1939) Gorbman (1950) for the pituitary-thyroid relationship; Kaltenbach (1953a and b) for the thyroid hormone; Katsch, Gordon and Charipper (1948) and Weinstein, Schiller and Charipper (1950) for adrenal hormones as they affect certain genital tissues.

BAGGETT, B., ENGEL, L. L., SAVARD, K., AND DORFMAN, R. I. 1956. The conversion of testosterone-3-C<sup>14</sup> to C<sup>14</sup>-estradiol-17 $\beta$  by human ovarian tissue. *J. Biol. Chem.*, **221**, 931-941.

BARR, M. L. 1957. Cytologic tests of chromosomal sex. In *Progress in Gynecology*, Vol. 3, pp. 131-141. New York: Grune and Stratton.

BARR, M. L., AND GRUMBACH, M. M. 1958. Cytologic tests of chromosomal sex in relation to sexual anomalies in man. *Recent Progr. Hormone Res.*, **14**, 225-344.

BASCOM, K. F. 1923. The interstitial cells of the gonads of cattle, with especial reference to their embryonic development and significance. *Am. J. Anat.*, **31**, 223-259.

BERTHOLD, A. A. 1849. Transplantation der Hoden. *Arch. Anat. Physiol. Wiss. med.*, **16**, 42-46.

BLIZZARD, R. M., AND ALBERTS, M. 1956. Hypopituitarism, hypoadrenalism, and hypogonadism in the newborn infant. *J. Pediat.*, **48**, 782-792.

BOUIN, P., AND ANCEL, P. 1903. Sur la signification de la glande interstitielle du testicule embryonnaire. *Compt. rend. Soc. biol.*, **55**, 1682-1684.

BRADLEY, E. M. 1941. Sex differentiation of chick and duck gonads as studied in homoplastic and heteroplastic host-graft combinations. *Anat. Rec.*, **79**, 507-529.

BREWER, D. B. 1957. Congenital absence of the pituitary gland and its consequences. *J. Path.*, **73**, 59-169.

BRONSKI, M. 1950. Development of embryonic guinea pig Müllerian ducts in anterior eye chamber grafts. *Proc. Soc. Exper. Biol. & Med.*, **75**, 426-429.

BRUNER, J. A. 1952. Further quantitative studies on the effects of androgens on sex determination in *Amblystoma* (abst.). *Anat. Rec.*, **113**, 564.

BRUNER, J. A., AND WITSCHI, E. 1946. Testosterone-induced modifications of sex development in female hamsters. *Am. J. Anat.*, **79**, 293-320.

BURNS, R. K. 1924. The sex of parabiotic twins in amphibians (abst.). *Anat. Rec.*, **27**, 198.

BURNS, R. K. 1925. The sex of parabiotic twins in *Amphibia*. *J. Exper. Zool.*, **42**, 31-89.

BURNS, R. K. 1928. The transplantation of larval gonads in urodele amphibians. *Anat. Rec.*, **39**, 177-191.

BURNS, R. K. 1930. The process of sex transformation in parabiotic *Amblystoma*. I. Transformation from female to male. *J. Exper. Zool.*, **55**, 123-129.

BURNS, R. K. 1931. The process of sex transformation in parabiotic *Amblystoma*. II. Transformation from male to female. *J. Exper. Zool.*, **60**, 339-387.

BURNS, R. K. 1934. The transplantation of the adult hypophysis into young salamander larvae. *Anat. Rec.*, **58**, 415-429.

BURNS, R. K. 1935. The process of sex transformation in parabiotic *Amblystoma*. III. Con-

- version of testis to ovary in heteroplastic pairs of *A. tigrinum* and *A. punctatum*. *Anat. Rec.*, **63**, 101-129.
- BURNS, R. K. 1938a. The effects of crystalline sex hormones on sex differentiation in *Amblystoma*. I. Estrone. *Anat. Rec.*, **71**, 447-467.
- BURNS, R. K. 1938b. Hormonal control of sex differentiation. *Am. Naturalist*, **72**, 207-227.
- BURNS, R. K. 1939a. The differentiation of sex in the opossum (*Didelphys virginiana*) and its modification by the male hormone testosterone propionate. *J. Morphol.*, **65**, 79-119.
- BURNS, R. K. 1939b. Sex differentiation during the early pouch stages of the opossum (*Didelphys virginiana*) and a comparison of the anatomical changes induced by male and female sex hormones. *J. Morphol.*, **65**, 497-547.
- BURNS, R. K. 1939c. The effects of crystalline sex hormones on sex differentiation in *Amblystoma*. II. Testosterone propionate. *Anat. Rec.*, **73**, 73-93.
- BURNS, R. K. 1942a. Hormones and experimental modification of sex in the opossum. *Biological Symposia*, **9**, 125-146.
- BURNS, R. K. 1942b. Hormones and the growth of the parts of the urinogenital apparatus in mammalian embryos. *Cold Spring Harbor Symposia Quant. Biol.*, **10**, 27-33.
- BURNS, R. K. 1942c. The origin and differentiation of the epithelium of the urinogenital sinus of the opossum, with a study of the modifications induced by estrogens. *Contr. Embryol., Carnegie Inst. Washington*, **30**, 63-83.
- BURNS, R. K. 1945a. Bisexual differentiation of the sex ducts in opossums as a result of treatment with androgen. *J. Exper. Zool.*, **100**, 119-140.
- BURNS, R. K. 1945b. The differentiation of the phallus in the opossum and its reactions to sex hormones. *Contr. Embryol., Carnegie Inst. Washington*, **31**, 147-162.
- BURNS, R. K. 1949. Hormones and the differentiation of sex. *Survey Biol. Progr.*, **1**, 233-266.
- BURNS, R. K. 1950. Sex transformation in the opossum: some new results and a retrospect. *Arch. Anat. microscop. et Morphol. expér.*, **39**, 467-481.
- BURNS, R. K. 1955a. Experimental reversal of sex in the gonads of the opossum, *Didelphys virginiana*. *Proc. Nat. Acad. Sc.*, **41**, 669-676.
- BURNS, R. K. 1955b. The urogenital system. In *Analysis of Development*, Willier, Weiss and Hamburger, Eds. Philadelphia: W. B. Saunders Company.
- BURNS, R. K. 1956a. Hormones versus constitutional factors in the growth of embryonic sex primordia in the opossum. *Am. J. Anat.*, **98**, 35-67.
- BURNS, R. K. 1956b. Transformation du testicule embryonnaire de l'opossum en ovotestis on en "ovaire" sous l'action de l'hormone femelle, le dipropionate d'oestradiol. *Arch. Anat. microscop. et Morphol. expér.*, **45**, 173-202.
- BURNS, R. K., AND BUYSSE, A. 1931. The effects of extracts of the mammalian hypophysis upon immature salamanders. *Anat. Rec.*, **51**, 155-185.
- BURROWS, H. 1949. *Biological Actions of Sex Hormones*, 2nd ed., Parts III and IV. London: Cambridge University Press.
- BUYSSE, A. 1935. The differentiation of transplanted mammalian gonad primordia. *J. Exper. Zool.*, **70**, 1-41.
- BUYSSE, A. 1936. A case of extreme sex-modification in an adult bovine freemartin. *Anat. Rec.*, **66**, 43-58.
- CHANG, C. Y. 1955. Hormonal influences on sex differentiation in the toad, *Bufo americanus*. *Anat. Rec.*, **123**, 467-486.
- CHANG, C. Y., AND WITSCHI, E. 1955. Independence of adrenal hyperplasia and gonadal masculinization in the experimental adrogenital syndrome of frogs. *Endocrinology*, **56**, 597-605.
- CHANG, C. Y., AND WITSCHI, E. 1956. Genic control and hormonal reversal of sex differentiation in *Xenopus*. *Proc. Soc. Exper. Biol. & Med.*, **93**, 140-144.
- CHAPIN, C. L. 1917. A microscopic study of the reproductive system of fetal freemartins. *J. Exper. Zool.*, **23**, 453-482.
- COLE, H. H., HART, G. H., LYONS, W. R., AND CATCHPOLE, H. R. 1933. The development and hormonal content of fetal horse gonads. *Anat. Rec.*, **56**, 275-293.
- CREW, F. A. E. 1923. Studies in intersexuality. II. Sex reversal in the fowl. *Proc. Roy. Soc., London, ser. B.*, **95**, 256-278.
- DANTCHAKOFF, V. 1935. Sur les différences de sensibilité des récepteurs tissulaires envers la folliculine, à divers stades embryonnaires. *Compt. rend. Acad. Sc.*, **201**, 161-163.
- DANTCHAKOFF, V. 1936. Réalisation du sexe à volonte par inductions hormonales. I. Inversion du sexe dans un embryon génétiquement mâle. *Bull. Biol. France et Belgique*, **70**, 241-307.
- DANTCHAKOFF, V. 1939. Les bases biologiques du "freemartinisme" et de "l'intersexualité hormonale" sont-elles les mêmes? *Compt. rend. Soc. biol.*, **130**, 1473-1476.
- DAVIS, M. E., AND POTTER, E. L. 1948. The response of the human fetal reproductive system to the administration of diethylstilbestrol and testosterone propionate during early pregnancy. *Endocrinology*, **42**, 370-378.
- DEANESLY, R. 1938. The androgenic activity of ovarian grafts in castrated male rats. *Proc. Roy. Soc., London, ser. B*, **126**, 122-135.
- DE BEAUMONT, J. 1933. La différenciation sexuelle dans l'appareil uro-génital du Triton et son déterminisme. *Rou. Arch. Entwicklungsmech. Organ.*, **129**, 120-178.
- DOMI, L. 1939. Modifications in sex and secondary sexual characters in birds. In *Sex and Internal Secretions*, 2nd ed., E. Allen, C. H. Danforth and E. A. Doisy, Eds., Ch. 5. Baltimore: The Williams & Wilkins Company.
- DORFMAN, R. I. 1957. Biochemistry of the steroid hormones. *Ann. Rev. Biochem.*, **26**, 523-560.

- ETKIN, W. 1936. A thyrotropic field surrounding the immature pituitary of the tadpole. *Proc. Soc. Exper. Biol. & Med.*, **34**, 508-512.
- ETKIN, W., AND HUTH, T. 1939. A thyrotropic field effect in the tadpole. *J. Exper. Zool.*, **82**, 463-495.
- FOOTE, C. L. 1938. Influence of hormones on sex differentiation in amphibia (*Rana pipiens*). *Anat. Rec., Suppl.*, **72**, 120-121.
- FOOTE, C. L. 1941. Modification of sex development in the marbled salamander by administration of synthetic sex hormones. *J. Exper. Zool.*, **86**, 291-319.
- FORBES, T. R. 1946. The origin of *Freemartin*. *Bull. Hist. Med.*, **20**, 461-466.
- FORBES, T. R. 1949. A. A. Berthold and the first endocrine experiment: some speculation as to its origin. *Bull. Hist. Med.*, **23**, 263-267.
- FORD, C. E., JONES, K. W., POLANI, P. E., DE ALMEIDA, J. C., AND BRIGGS, J. H. 1959. A sex-chromosome anomaly in a case of gonadal dysgenesis (Turner's syndrome). *Lancet*, April 4, 711-713.
- FUGO, N. W. 1940. Effects of hypophysectomy in the chick embryo. *J. Exper. Zool.*, **85**, 271-295.
- GAARENSTROOM, J. H. 1939. Action of sex hormones on the development of the Müllerian duct of the chick embryo. *J. Exper. Zool.*, **82**, 31-46.
- GALLIEN, L. 1940. Sur l'action amphisexuelle de la dihydrofolliculine dans la différenciation du sexe chez les Batraciens. *Compt. rend. Acad. Sc.*, **211**, 665-666.
- GALLIEN, L. 1941. Recherches expérimentales sur l'action amphisexuelle de l'hormone femelle (oestradiol), dans la différenciation du sexe chez *Rana temporaria* L. *Bull. Biol. France et Belgique*, **75**, 369-397.
- GALLIEN, L. 1944. Recherches expérimentales sur l'organogénèse sexuelle chez les Batraciens Anoures. *Bull. Biol. France et Belgique*, **78**, 257-359.
- GALLIEN, L. 1950. Les hormones sexuelles dans la différenciation du sexe chez les Amphibiens. *Arch. Anat. microscop. et Morphol. expér.*, **39**, 337-360.
- GALLIEN, L. 1953. Inversion totale du sexe chez *Xenopus laevis* Daud. à la suite d'un traitement gynogène par le benzoate d'oestradiol administré pendant la vie larvaire. *Compt. rend. Acad. Sc.*, **237**, 1565-1566.
- GALLIEN, L. 1954. Inversion expérimentelle du sexe sous l'action des hormones sexuelles chez le Triton, *Pleurodeles waltlii* (etc.). *Bull. Biol. France et Belgique*, **88**, 1-51.
- GALLIEN, L. 1955. The action of sex hormones on the development of sex in Amphibia. *Memoirs, Society of Endocrinology*, No. 4, pp. 188-204. London: Cambridge University Press.
- GODET, R. 1949. Recherches d'anatomie et d'embryologie normale et expérimentale sur l'appareil génitale de la taupe. *Bull. Biol. France et Belgique*, **83**, 25-111.
- GODET, R. 1950. La différenciation du sexe chez la taupe. *Arch. Anat. microscop. et Morphol. expér.*, **39**, 627-633.
- GORBMAN, A. 1950. Reactions of thyroid glands to juxtathyroidal implants of thyrotropic agents. *Endocrinology*, **46**, 397-402.
- GRAHAM, M. A. 1956. Sex chromatin in *Didelphys virginiana* (abstr.). *Anat. Rec.*, **124**, 403.
- GRAYHACK, J. T. 1958. The effect of local testosterone administration on the prostate of the rat. *Endocrinology*, **63**, 399-402.
- GREENE, R. R. 1942. Hormonal factors in sex inversion: the effects of sex hormones on embryonic sexual structures of the rat. *Biological Symposia*, **9**, 105-123.
- GREENWOOD, A. W., AND BLYTH, J. S. I. 1935. Variation in plumage response of brown Leghorn capons to estrone. Intradermal injection. *Proc. Roy. Soc.*, **118**, 122.
- HANAOKA, K. 1941a. The effect of follicular hormone upon the sex differentiation in *Hynobius retardatus*. *J. Fac. Sc., Hokkaido University*, ser. VI, Zool., **7**, 399-412.
- HANAOKA, K. 1941b. The effect of testosterone propionate upon the sex differentiation in *Hynobius retardatus*. *J. Fac. Sc., Hokkaido Univ.*, ser. VI, Zool., **7**, 413-419.
- HAY, D. 1950. Étude d'un freemartin spontané chez les ruminants. *Arch. Anat. Histol. et Embryol.*, **33**, 55-79.
- HEARD, R. D. H., JELLINEK, P. H., AND O'DONNELL, V. J. 1955. Biogenesis of the estrogens: the conversion of testosterone-4-C<sup>14</sup> to estrone in the pregnant mare. *Endocrinology*, **57**, 200-204.
- HILL, R. T. 1937a. Ovaries secrete male hormone. I. Restoration of the castrate type of seminal vesicle and prostate glands to normal by grafts of ovaries in mice. *Endocrinology*, **21**, 495-502.
- HILL, R. T. 1937b. Ovaries secrete male hormone. III. Temperature control of male hormone output by grafted ovaries. *Endocrinology*, **21**, 633-636.
- HOLLANDER, W. F., GOWEN, J. W., AND STADLER, J. 1956. A study of 25 gynandromorphic mice of the Bagg albino strain. *Anat. Rec.*, **124**, 223-243.
- HOLYOKE, E. A. 1949. The differentiation of embryonic gonads transplanted to the adult omentum in the albino rat. *Anat. Rec.*, **103**, 675-699.
- HOUILLON, C. 1956. Recherches expérimentales sur la dissociation médullo-corticale dans l'organogénèse des gonades chez le Triton, *Pleurodeles waltlii* Michah. *Bull. Biol. France et Belgique*, **90**, 339-445.
- HUIJBERS, M. 1951. The influence of the gonads on the development of the reproductive system in the chick embryo. Summary of Thesis, Anatomy and Embryology Laboratory, University of Amsterdam.
- HUMPHREY, R. R. 1928a. The developmental potencies of the intermediate mesoderm of *Amblystoma* when transplanted into ventrolateral sites in other embryos: the primordial

- cells of such grafts and their role in the development of a gonad. *Anat. Rec.*, **40**, 67-101.
- HUMPHREY, R. R. 1928b. Sex differentiation in gonads developed from transplants of the intermediate mesoderm of *Amblystoma*. *Biol. Bull.*, **55**, 317-339.
- HUMPHREY, R. R. 1932. Sex of parabiotic twins in *Amblystoma maculatum*. *Proc. Soc. Exper. Biol. & Med.*, **29**, 713-717.
- HUMPHREY, R. R. 1935a. Studies on sex reversal in *Amblystoma*. VII. Reversal of sex type in gonadic preprimordia of *A. punctatum* males implanted in females of more rapidly growing species. *Anat. Rec.*, **62**, 223-245.
- HUMPHREY, R. R. 1935b. Sex reversal in *Amblystoma*. VIII. Sex type of gonads developed from gonadic preprimordia of *A. punctatum* implanted in Axolotl females. *Proc. Soc. Exper. Biol. & Med.*, **33**, 102-104.
- HUMPHREY, R. R. 1942. Sex inversion in the Amphibia. *Biological Symposia*, **9**, 81-104.
- IWASAWA, H. 1958. Effects of some steroid hormones on the gonads of *Rhacophorus larca*. *J. Fac. Sc. Niigata Univ.*, ser. II, **2**, 179-188.
- JOST, A. 1947a. Recherches sur la différenciation de l'embryon de lapin. II. Action des androgènes synthèse sur l'histogénèse génitale. *Arch. Anat. microscop. et Morphol. expér.*, **36**, 242-270.
- JOST, A. 1947b. Recherches sur la différenciation de l'embryon de lapin. III. Rôle des gonades foetales dans la différenciation sexuelle somatique. *Arch. Anat. microscop. et Morphol. expér.*, **36**, 271-315.
- JOST, A. 1947c. The age factor in the castration of male rabbit fetuses. *Proc. Soc. Exper. Biol. & Med.*, **66**, 302-303.
- JOST, A. 1947d. Expériences de décapitation de l'embryon de lapin. *Compt. rend. Acad. Sc.*, **225**, 322.
- JOST, A. 1948a. Le contrôle hormonal de la différenciation du sexe. *Biol. Rev.*, **23**, 201-236.
- JOST, A. 1948b. Activité androgène du testicule foetal de rat greffé sur l'adulte castré. *Compt. rend. Soc. biol.*, **142**, 196-198.
- JOST, A. 1950. Sur le contrôle hormonal de différenciation sexuelle du lapin. *Arch. Anat. microscop. et Morphol. expér.*, **39**, 577-598.
- JOST, A. 1951a. Recherches sur la différenciation sexuelle de l'embryon de lapin. IV. Organogénèse sexuelle masculine après décapitation du foetus. *Arch. Anat. microscop. et Morphol. expér.*, **40**, 247-281.
- JOST, A. 1951b. La physiologie de l'hypophyse foetale. *Biol. Méd.*, **40**, 205-229.
- JOST, A. 1953. Problems of fetal endocrinology: the gonadal and hypophyseal hormones. *Recent Progr. Hormone Res.*, **8**, 379-418.
- JOST, A. 1955. Modalities in the action of gonadal and gonad-stimulating hormones in the fetus. In *Memoirs Society of Endocrinology*, No. 4, pp. 237-248. London: Cambridge University Press.
- JOST, A. 1957. La fonction endocrine du testicule foetal. In *La Fonction endocrine du Testicule*. Paris: Masson et Cie.
- JOST, A. 1958. Embryonic sexual differentiation. In *Hermaphroditism, Genital Anomalies, and Related Endocrine Disorders*. H. W. Jones and W. W. Scott, Eds., pp. 15-45. Baltimore: The Williams & Wilkins Co.
- JOST, A., ET BERGERARD, Y. 1949. Culture *in vitro* d'ébauches du tractus génital du foetus de rat. *Compt. rend. Soc. biol.*, **143**, 608-609.
- JOST, A., ET BOZIC, B. 1951. Données sur la différenciation des conduits génitaux du foetus de rat étudiée *in vitro*. *Compt. rend. Soc. biol.*, **145**, 647-650.
- JOST, A., ET COLONGE, R. A. 1949. Greffe de testicule foetal de Rat sur l'adulte castré et hypophysectomisé. Remarques sur la physiologie du testicule foetal de Rat. *Compt. rend. Soc. biol.*, **143**, 140.
- JOST, A., ET GONSE, P. 1953. Application de la méthode à l'acide périodique-Schiff (Mac-Manus) à l'étude histophysiologique de l'hypophyse foetale du lapin. *Arch. Anat. microscop. et Morphol. expér.*, **42**, 243.
- JOST, A., ET TAVERNIER, R. 1956. Application de la méthode à l'acide périodique-Schiff (Mac-Manus) à l'étude de l'hypophyse foetale du rat. *Compt. rend. Acad. Sc.*, **243**, 1353-1356.
- KALTENBACH, J. C. 1953a. Local action of thyroxine on amphibian metamorphosis. I. Local metamorphosis in *Rana pipiens* larvae effected by thyroxine-cholesterol implants. *J. Exper. Zool.*, **122**, 21-39.
- KALTENBACH, J. C. 1953b. Local action of thyroxine on amphibian metamorphosis. II. Development of the eyelids, nictitating membrane, cornea, and extrinsic ocular muscles in *Rana pipiens* larvae effected by thyroxine-cholesterol implants. *J. Exper. Zool.*, **122**, 41-51.
- KATSCH, S., GORDON, A. S., AND CHARIPPER, H. A. 1948. The andromimetic action of adrenal cortical transplants to the seminal vesicle of the adult rat. *Anat. Rec.*, **101**, 47-57.
- KELLER, K., UND TANDLER, J. 1916. Über des Verhalten der Eihäute bei der Zwillingsstrichtigkeit des Kindes. Untersuchungen über die Entstehungsursache der geschlechtlichen Unterentwicklung von weiblichen Zwillingskälbern, welche neben einem männlichen Kalbe zur Entwicklung gelangen. *Wien Tierärztl. Wchnschr.*, **3**, 513.
- KERKITOF, A. M. 1952. De Morphogenese van de tractus uro-genitalis onder invloed van testosteronepropionaat (experimental intersexuality). Doctoral Thesis, Faculty of Embryology, University of Leyden.
- KIRKMAN, H. 1958. A hypophysectomized gynaecomorphic Syrian hamster. *Anat. Rec.*, **131**, 213-231.
- KOZELKA, A. W., AND GALLAGHER, T. F. 1934. Effect of male hormone extracts, theelin, and theclon on the chick embryo. *Proc. Soc. Exper. Biol. & Med.*, **31**, 1143-1144.

- LAVELLE, F. W. 1951. A study of hormonal factors in the early sex development of the golden hamster. *Contrib. Embryol. Carnegie Inst. Washington*, **34**, 19-53.
- LEROY, P. 1948. Effet androgène d'extraits embryonnaires de Poulet sur la crête du Chapon. *Compt. rend. Acad. Sc.*, **226**, 520.
- LEWIS, L. B. 1946. A study of some effects of sex hormones upon the embryonic reproductive system of the white pekin duck. *Physiol. Zool.*, **19**, 282-329.
- LEWIS, L. B., AND DOMM, L. V. 1948. A sexual transformation of the oesous bulla in duck embryos following administration of estrogen. *Physiol. Zool.*, **21**, 65-69.
- LILLIE, F. R. 1916. The theory of the freemartin. *Science*, **43**, 611-613.
- LILLIE, F. R. 1917. The freemartin: a study of the action of sex hormones in the fetal life of cattle. *J. Exper. Zool.*, **23**, 371-452.
- LILLIE, F. R. 1923. Supplementary notes on twins in cattle. *Biol. Bull.*, **44**, 47-78.
- LILLIE, F. R. 1931. Bilateral gynandromorphism and lateral hemihypertrophy in birds. *Science*, **74**, 387-390.
- LILLIE, F. R., AND BASCOM, K. F. 1922. An early stage of the freemartin and the parallel history of the interstitial cells. *Science*, **55**, 624-625.
- LUTZ, H., AND LUTZ-OSTERTAG, Y. 1958. Étude d'un freemartin chez les oiseaux. *Arch. Anat. Microscop. et Morphol. expér.*, **47**, 205-210.
- MCCRADY, E., JR. 1938. The embryology of the opossum. In *American Anatomical Memoirs*, No. 16. Philadelphia; Wistar Institute of Anatomy and Biology.
- MCINTYRE, M. N. 1956. Effect of the testis on ovarian differentiation in heterosexual embryonic rat gonad transplants. *Anat. Rec.*, **124**, 27-46.
- MINOTRA, T. 1921. A study of testis and ovary grafts on the hen's egg and their effects on the embryos. *J. Exper. Zool.*, **33**, 1-61.
- MINTZ, B. 1947. Effects of testosterone propionate on sex development in female *Amblystoma* larvae. *Physiol. Zool.*, **20**, 355-373.
- MINTZ, B. 1948. Testosterone minimum for induction of male development in *Amblystoma*; comparative data from other vertebrates. *Proc. Soc. Exper. Biol. & Med.*, **69**, 358-361.
- MINTZ, B., FOOTE, C. L., AND WITSCHI, E. 1945. Quantitative studies on response of sex characters of differentiated *Rana clamitans* larvae to injected androgens and estrogens. *Endocrinology*, **37**, 286-296.
- MONBAERTS, J. 1944. Le sinus urogénital et les glandes annexes du Hérisson (*Eriacus europaeus* L.). *Arch. Biol., Liège*, **55**, 393-554.
- MOORE, C. R. 1941. On the role of sex hormones in sex differentiation in the opossum (*Didelphys virginiana*). *Physiol. Zool.*, **14**, 1-45.
- MOORE, C. R. 1945. Prostate gland induction in the female opossum by hormones and the capacity of the gland for development. *Am. J. Anat.*, **76**, 1-31.
- MOORE, C. R. 1947. *Embryonic Sex Hormones and Sexual Differentiation*. Springfield, Ill.: Charles C Thomas.
- MOORE, C. R., AND PRICE, D. 1932. Gonad hormone functions, and the reciprocal influence between gonads and hypophysis with its bearing on the problem of sex-hormone antagonism. *Am. J. Anat.*, **50**, 13-71.
- MOORE, C. R., AND PRICE, D. 1942. Differentiation of embryonic reproductive tissues of the rat after transplantation into postnatal hosts. *J. Exper. Zool.*, **90**, 229-265.
- MOORE, K. L., GRAHAM, M. A., AND BARR, M. L. 1957. The sex chromatin of the bovine freemartin. *J. Exper. Zool.*, **135**, 101-126.
- NOBLE, G. K. 1931. *The Biology of the Amphibia*. New York and London: McGraw-Hill Book Company, Inc.
- OWEN, R. R., DAVIS, H. P., AND MORGAN, R. F. 1946. Quintuplet calves and erythrocyte mosaicism. *J. Hered.*, **37**, 291-297.
- PADOA, E. 1936. Effetto paradossale (mascolinizazione) sulla differenziazione sessuale di girini di *Rana esculenta* trattati con ormone follicolare. *Monit. Zool. ital.*, **47**, 285.
- PADOA, E. 1938. La differenziazione del sesso invertita mediante la somministrazione di ormoni sessuali. Ricerche con follicolina in *Rana esculenta*. *Arch. Ital. Anat. e Embryol.*, **40**, 122-172.
- PADOA, E. 1942. Il differenziamento del sesso invertito mediante la somministrazione di ormoni sessuali e corticosteroidi. Ricerche con didrofollicolina, progesterone e acetato di deossicorticosterone, in *Rana esculenta*. *Pubbl. Staz. Zool. Napoli*, **19**, 185-223.
- PADOA, E. 1947. Differente sensibilità al testosterone dei genotipi maschili e femminili di *Rana dabuatina*. *Arch. Zool. ital.*, **32**, 1-21.
- PADOA, E. 1950. Grenouilles et stéroïdes. *Arch. Anat. Microscop. et Morphol. expér.*, **39**, 315-333.
- PAINTER, T. S. 1922. Studies in mammalian spermatogenesis. I. The spermatogenesis of the opossum (*Didelphys virginiana*). *J. Exper. Zool.*, **35**, 13-45.
- PARKES, A. S. 1954. Some aspects of the endocrine environment of the fetus. *Cold Spring Harbor Symposia Quant. Biol.*, **19**, 3-8.
- PEYRE, A. 1952. Note sur la structure de l'ovaire du desman des Pyrénées. *Bull. Soc. Zool. France*, **77**, 441-447.
- PEYRE, A. 1955. Intersexualité du tractus génital femelle du desman des Pyrénées. *Bull. Soc. Zool. France*, **80**, 132-138.
- PIQUET, J. 1930. Détermination du sexe chez les Batraciens en fonction de la température. *Rev. Suisse Zool.*, **37**, 173-281.
- PONSE, K. 1924. L'organe de Bidder et le déterminisme des caractères sexuels secondaires du Crapaud (*Bufo vulgaris* L.). *Rev. suisse Zool.*, **31**, 177-336.

- PONSE, K. 1948. Actions paradoxales des glandes génitales. Rev. suisse Zool., **55**, 477-531.
- PONSE, K. 1949. *La Différenciation du Sexe et l'Intersexualité chez les Vertébrés*. Lausanne: F. Rouge.
- PRICE, D. 1947. An analysis of the factors influencing growth and development of the mammalian reproductive tract. Physiol. Zool., **20**, 213-247.
- PRICE, D. 1956. Influence of hormones on sex differentiation in explanted fetal reproductive tracts. Macy Foundation Conferences on Gestation, **3**, 173-185.
- PRICE, D., AND PANNABECKER, R. 1956. Organ culture studies of foetal rat reproductive tracts. Ciba Foundation Colloquia Aging, **2**, 3-13.
- PUCKETT, W. O. 1939. Some reactions of the gonads of *Rana catesbeiana* tadpoles to injections of mammalian hormonal substances. J. Exper. Zool., **81**, 43-65.
- PUCKETT, W. O. 1940. Some effects of crystalline sex hormones on the differentiation of the gonads of an undifferentiated race of *Rana catesbeiana* tadpoles. J. Exper. Zool., **84**, 39-51.
- RAWLES, M. E. 1936. A study in the localization of organ-forming areas in the chick blastoderm of the head-process stage. J. Exper. Zool., **72**, 271-315.
- RAYNAUD, A. 1942. Modification expérimentale de la différenciation sexuelle des embryons de souris, par action des hormones androgènes et oestrogènes. Actual. Scient. et Indust., Nos. 925 et 926. Hermann, Ed. Paris.
- RAYNAUD, A. 1950. Recherches expérimentales sur le développement de l'appareil génital et le fonctionnement des glandes endocrines des foetus de souris et de mulot. Arch. Anat. microscop. et Morphol. expér., **39**, 518-569.
- RAYNAUD, A., ET FRILLEY, M. 1947. Destruction des glandes génitales de l'embryon de souris par une irradiation au moyen des rayons x, à l'âge de 13 jours. Ann. Endocrinol., **8**, 400-419.
- REINHOLD, R. 1951. Le rudiment de tubercle génital du poulet: développement embryonnaire et sensibilité aux hormones sexuelles. Bull. Biol. France et Belgique, **85**, 347-367.
- ROBSON, J. M. 1951. Local action of steroids on secondary sex organs of male rats. J. Physiol., **113**, 537-541.
- SEGAL, S. J. 1953. Morphogenesis of the estrogen induced hyperplasia of the adrenals in larval frogs. Anat. Rec., **115**, 205-230.
- SMITH, P. E. 1932. In *Sex and Internal Secretions*, 1st ed., E. Allen, Ed. Baltimore: The Williams & Wilkins Company.
- SPIERT, H. 1948. The local action of sex hormones. Physiol. Rev., **28**, 23-50.
- SPRATT, N. T., JR., AND WILLIER, B. H. 1939. Embryonic sex differentiation. Tabulae Biologicae, **17**, 1-23.
- STOLL, R. 1948. Actions de quelques hormones sexuelles sur le développement des canaux de Müller de l'embryon de poulet. Arch. Anat. microscop. et Morphol. expér., **37**, 118-135.
- STOLL, R. 1950. Sur la différenciation sexuelle de l'embryon de poulet. Arch. Anat. microscop. Morphol. expér., **39**, 415-423.
- STORMONT, C., WEIR, W. C., AND LANE, L. L. 1953. Erythrocyte mosaicism in a pair of sheep twins. Science, **118**, 695-696.
- TUJO, J. H. AND PUCK, T. T. 1958. Genetics of somatic mammalian cells. II. Chromosomal constitution of cells in tissue culture. J. Exper. Med., **108**, 259-268.
- TORREY, T. 1950. Intraocular grafts of embryonic gonads of the rat. J. Exper. Zool., **115**, 37-58.
- TURNER, C. D. 1939. The modification of sexual differentiation in genetic female mice by the prenatal administration of testosterone propionate. J. Morphol., **65**, 353-381.
- TURNER, C. D. 1940. The influence of testosterone propionate upon sexual differentiation in genetic female mice (etc.). J. Exper. Zool., **83**, 1-31.
- UCHIDA, T. 1937. Studies on the sexuality of Amphibia. III. Sex-transformation in *Hynobius retardatus* by the function of high temperature. J. Fac. Sc. Hokkaido University, ser. VI, Zool., **6**, 35-58.
- VAN DETH, J. H. M. G., VAN LIMBORGH, J., ET VAN FAASSEN, F. 1956. Le rôle de l'hypophyse dans la détermination du sexe de l'oiseau. Acta Morphol. neerl.-scandinav., **1**, 70-80.
- VANNINI, E. 1941. Rapida azione masculinizzante del testosterone sulle gonadi di girini di *Rana agilis* in metamorfosi. Rend. R. Accad. ital., ser. 7, **2**, 666-676.
- WEINSTEIN, M. J., SCHILLER, J., AND CHARIPPER, H. A. 1950. Estrogenic activity of adrenal transplants to the uterus of ovariectomized rats. Anat. Rec., **108**, 441-455.
- WELLS, L. J. 1946. Effects of androgen upon reproductive organs of normal and castrated fetuses with note on adrenalectomy. Proc. Soc. Exper. Biol. & Med., **63**, 417-419.
- WELLS, L. J. 1947. Progress of studies designed to determine whether the fetal hypophysis produces hormones that influence development (abst.). Anat. Rec., **97**, 409.
- WELLS, L. J. 1950. Hormones and sexual differentiation in placental mammals. Arch. Anat. microscop. et Morphol. expér., **39**, 499-514.
- WELLS, L. J., CAVANAUGH, M. W., AND MAXWELL, E. L. 1954. Genital abnormalities in castrated fetal rats and their prevention by means of testosterone propionate. Anat. Rec., **118**, 109-134.
- WELLS, L. J., AND FRALICK, R. 1951. Production of androgen by the testes of fetal rats. Am. J. Anat., **89**, 63-107.
- WELLS, L. J., AND VAN WAGENEN, G. 1954. Androgen-induced female pseudohermaphroditism in the monkey (*Macaca mulatta*): anatomy of the reproductive organs. Contr. Embryol., Carnegie Inst. Washington, **35**, 93-106.
- WEST, C. D., DAMAST, B. L., SARRO, S. D., AND PEARSON, O. H. 1956. Conversion of testosterone to estrogens in castrated and adrenalect-



- tomized human females. *J. Biol. Chem.*, **218**, 409-418.
- WHITE, M. R. 1949. Effects of hormones on embryonic sex differentiation in the golden hamster. *J. Exper. Zool.*, **110**, 153-181.
- WIESNER, B. P. 1934. The postnatal development of the genital organs of the albino rat, with a discussion of a new theory of sexual differentiation. *J. Obstet. & Gynaec. Brit. Emp.*, **41**, 867-922.
- WIESNER, B. P. 1935. The postnatal development of the genital organs in the albino rat, with a discussion of a new theory of sexual differentiation. *J. Obst. & Gynaec. Brit. Emp.*, **42**, 8-78.
- WILKINS, L. 1950. *The Diagnosis and Treatment of Endocrine Disorders in Childhood and Adolescence*. Springfield, Ill.: Charles C Thomas.
- WILLIER, B. H. 1921. Structures and homologues of freemartin gonads. *J. Exper. Zool.*, **33**, 63-127.
- WILLIER, B. H. 1927. The specificity of sex, of organization, and of differentiation of embryonic chick gonads as shown by grafting experiments. *J. Exper. Zool.*, **46**, 409-465.
- WILLIER, B. H. 1933. Potencies of the gonad-forming area in the chick as tested in chorio-allantoic grafts. Roux' Arch. Entwicklungsmech. Organ., **130**, 616-649.
- WILLIER, B. H. 1939. The embryonic development of sex. In *Sex and Internal Secretions*, 2nd ed., Allen, Danforth and Doisy, Eds., Ch. 3. Baltimore: The Williams & Wilkins Company.
- WILLIER, B. H. 1952. Development of sex-hormone activity of the avian gonad. *Ann. New York Acad. Sc.*, **55**, 159-171.
- WILLIER, B. H. 1955. Ontogeny of endocrine correlation. In *Analysis of Development*. Philadelphia: W. B. Saunders Company.
- WILLIER, B. H., GALLAGHER, T. F., AND KOCH, F. C. 1935. Sex-modification in the chick embryo resulting from injections of male and female hormones. *Proc. Nat. Acad. Sc.*, **21**, 625-631.
- WILLIER, B. H., GALLAGHER, T. F., AND KOCH, F. C. 1937. The modification of sex development in the chick embryo by male and female sex hormones. *Physiol. Zool.*, **10**, 101-122.
- WILLIER, B. H., AND RAWLES, M. E. 1935. Organ-forming areas in the early chick blastoderm. *Proc. Soc. Exper. Biol. & Med.*, **32**, 1293-1296.
- WILLIER, B. H., AND YUH, E. C. 1928. The problem of sex differentiation in the chick embryo with reference to the effects of gonad and non-gonad grafts. *J. Exper. Zool.*, **52**, 65-125.
- WITSCHI, E. 1927. Sex-reversal in parabiotic twins of the American wood-frog. *Biol. Bull.*, **52**, 137-146.
- WITSCHI, E. 1929. Studies on sex differentiation and sex determination in amphibians. II. Sex reversal in female tadpoles of *Rana sylvatica* following the application of high temperature. *J. Exper. Zool.*, **52**, 267-291.
- WITSCHI, E. 1932. Sex deviations, inversions, and parabiosis. In *Sex and Internal Secretions*, 1st ed., E. Allen, Ed., Ch. 5. Baltimore: The Williams & Wilkins Company.
- WITSCHI, E. 1933. Studies in sex differentiation and sex determination in amphibians. VI. The nature of Bidder's organ in the toad. *Am. J. Anat.*, **52**, 461-515.
- WITSCHI, E. 1934. Genes and inductors of sex differentiation in amphibians. *Biol. Rev.*, **9**, 460-488.
- WITSCHI, E. 1937. Studies on sex differentiation and sex determination in amphibians. IX. Quantitative relationships in the induction of sex differentiation, and the problem of sex-reversal in parabiotic salamanders. *J. Exper. Zool.*, **75**, 313-373.
- WITSCHI, E. 1939. Modification of the development of sex in lower vertebrates and in mammals. In *Sex and Internal Secretions*, 2nd ed., Allen, Danforth and Doisy, Eds., Ch. 4. Baltimore: The Williams & Wilkins Company.
- WITSCHI, E. 1942. Hormonal regulation of development in lower vertebrates. Cold Spring Harbor Symposia Quant. Biol., **10**, 145-151.
- WITSCHI, E. 1950. Génétique et physiologie de la différenciation du sexe. *Arch. Anat. microscop. et Morphol. expér.*, **39**, 215-240.
- WITSCHI, E. 1951. Adrenal hyperplasia in larval frogs treated with natural estrogens. *Anat. Rec.*, **111**, 35-36.
- WITSCHI, E. 1952. Mechanism of adrenal hyperplasia and androgenicity. *Science*, **116**, 530.
- WITSCHI, E. 1953. The experimental adrenogenital syndrome in the frog. *J. Clin. Endocrinol.*, **13**, 316-329.
- WITSCHI, E. 1957. The inductor theory of sex differentiation. *J. Fac. Sc., Hokkaido Univ., ser. VI, Zool.*, **13**, 428-439.
- WITSCHI, E., FOOTE, C. L., AND CHANG, C. Y. 1958. Modification of sex differentiation by steroid hormones in a tree frog, *Pseudacris nigrita triseriata* Wied. *Proc. Soc. Exper. Biol. & Med.*, **97**, 196-197.
- WITSCHI, E., AND McCURDY, H. M. 1929. The freemartin effect in experimental parabiotic twins of *Triturus torosus*. *Proc. Soc. Exper. Biol. & Med.*, **26**, 655-657.
- WOLFF, EM. 1950. La différenciation sexuelle normale et le conditionnement hormonal des caractères sexuels somatiques précoces, tubercule génital et syrinx, chez l'embryon de canard. *Bull. Biol. France et Belgique*, **84**, 119-193.
- WOLFF, ET. 1937. L'hypophyse et la thyroïde jouent-elles un rôle dans la détermination expérimentale de l'intersexualité chez l'embryon du poulet. *Compt. rend. Soc. biol.*, **126**, 1217-1218.
- WOLFF, ET. 1938. L'action des hormones sexuelles sur les voies génitales femelles des embryons de poulet. *Trav. Stat. Zool. Wimereux*, **13**, 825-840.
- WOLFF, ET. 1946. Recherches sur l'intersexualité expérimentale produite par la méthode de greffes de gonades à l'embryon de poulet. *Arch. Anat. microscop. et Morphol. expér.*, **36**, 87-91.

- WOLFF, ET. 1947. Essai d'interprétation des résultats obtenus récemment chez les Vertébrés sur l'intersexualité hormonale. *Experientia*, **3**, 272-276, 301-304.
- WOLFF, ET. 1948. Sur l'induction expérimentelle de l'ovaire droit chez l'embryon d'oiseau. *Compt. rend. Acad. Sc.*, **226**, 1140-1141.
- WOLFF, ET. 1950. Le rôle des hormones embryonnaires dans la différenciation sexuelle des oiseaux. *Arch. Anat. microscop. et Morphol. expér.*, **39**, 426-444.
- WOLFF, ET. 1953a. La croissance et différenciation des organes embryonnaires des vertébrés amniotes en culture *in vitro*. *J. Suisse Med.*, **83**, 171-175.
- WOLFF, ET. 1953b. Le déterminisme de l'atrophie d'un organe rudimentaire: le canal de Müller des embryons mâles d'oiseaux. *Experientia*, **9**, 121-133.
- WOLFF, ET., ET GINGLINGER, A. 1935. Sur la transformation des poulets mâles en intersexués par injection d'hormone femelle (folliculine) aux embryons. *Arch. Anat., Hist. et Embryol.*, **20**, 219-278.
- WOLFF, ET., ET HAFFEN, K. 1952a. Sur le développement et la différenciation sexuelle des gonades embryonnaires d'oiseau en culture *in vitro*. *J. Exper. Zool.*, **119**, 381-404.
- WOLFF, ET., ET HAFFEN, K. 1952b. Sur l'intersexualité expérimentelle des gonades embryonnaires de canard cultivées *in vitro*. *Arch. Anat. microscop. Morphol. expér.*, **41**, 184-207.
- WOLFF, ET., HAFFEN, K., ET WOLFF, EM. 1953. Les besoins nutritifs des organes sexués embryonnaires en culture *in vitro*. *Ann. Nutrition et Alim.*, **7**, 5-22.
- WOLFF, ET., ET LUTZ-OSTERTAG, Y. 1952. La différenciation et la régression des canaux de Müller de l'embryon de poulet en culture *in vitro*. *Compt. rend. A. anat.*, Avril, 1952.
- WOLFF, ET., LUTZ-OSTERTAG, Y., ET HAFFEN, K. 1952. Sur la régression et la nécrose *in vitro* des canaux de Müller de l'embryon de poulet sous l'action directe des hormones mâles. *Compt. rend. Soc. biol.*, **146**, 1793-1795.
- WOLFF, ET., ET OSTERTAG, Y. 1949. Sur l'évolution des canaux de Müller chez l'embryon de poulet explantés en greffes chorio-allantoïdiennes. *Compt. rend. Soc. biol.*, **143**, 866-869.
- WOLFF, ET., ET STOLL, R. 1937. Le rôle de l'hypophyse dans le développement embryonnaire du poulet d'après l'étude de cycloécéphales expérimentaux. *Compt. rend. Soc. biol.*, **126**, 1215-1217.
- WOLFF, ET., STRUDEL, G., ET WOLFF, EM. 1948. L'action des hormones androgènes sur la différenciation sexuelle des embryons de poulets. *Arch. Anat., Hist., et Embryol.*, **31**, 237-310.
- WOLFF, ET., ET WOLFF, EM. 1951. The effects of castration on bird embryos. *J. Exper. Zool.*, **116**, 59-97.
- WOLFF, ET., ET WOLFF, EM. 1952a. Le déterminisme de la différenciation sexuelle de la syrinx du canard cultivée *in vitro*. *Biol. Bull. France et Belgique*, **86**, 325-349.
- WOLFF, EM., ET WOLFF, ET. 1952b. Sur la différenciation *in vitro* du tubercle génital de l'embryon de canard. *Compt. rend. Soc. biol.*, **146**, 492-493.
- WOTIZ, H. H., DAVIS, J. W., LEMON, H. M., AND GUT, M. 1956. Studies in steroid metabolism. V. The conversion of testosterone-4-C<sup>14</sup> to estrogens by human ovarian tissue. *J. Biol. Chem.*, **222**, 487-495.
- YAMAMOTO, T. 1953. Artificially induced sex-reversal in genotypic males of the medaka (*Oryzias latipes*). *J. Exper. Zool.*, **123**, 571-594.
- YAMAMOTO, T. 1958. Artificial induction of functional sex-reversal in genotypic females of the medaka (*Oryzias latipes*). *J. Exper. Zool.*, **137**, 227-260.

SECTION B

---

*The Hypophysis and the  
Gonadotrophic Hormones  
in Relation to Reproduc-  
tion*



# 3

## MORPHOLOGY OF THE HYPOPHYSIS RELATED TO ITS FUNCTION

*Herbert D. Purves, M.Sc., M.B., Ch.B.*

DIRECTOR, ENDOCRINOLOGY RESEARCH  
OTAGO UNIVERSITY, DUNEDIN, NEW ZEALAND

I. INTRODUCTION.....	162	C. Hormone Content of Basophil Granules.....	183
II. EMBRYONIC DEVELOPMENT.....	162	D. Does the Periodic Acid-Schiff Reaction Demonstrate the Hormone Content of Basophil Cells?.....	183
III. ANATOMIC SUBDIVISIONS OF THE HYPOPHYSIS. DEFINITION OF TERMS.....	163	E. Differential Staining of Basophil Cells by Resorcin-Fuchsin, Kresofuchsin, Aldehyde-Fuchsin, and Alcian Blue: $\beta$ -Cells and $\delta$ -Cells.....	184
A. Anatomic Divisions and Components.....	163	F. The Nomenclature of Basophil Cells.....	187
B. Histologic Divisions of the Hypophysis: Functional Parts.....	166	G. Specific Basophil Cell Types.....	187
C. Zones in the Pars Anterior and Pars Distalis.....	167	H. The Three Functional Types of Basophil Cell in the Rat Hypophysis.....	188
IV. A GENERAL STATEMENT OF THE PROBLEMS OF THE SPECIAL CYTOLOGY OF THE HYPOPHYSIS.....	167	1. The Pars Anterior of the Rat with Special Reference to Two Types of Gonadotrophs.....	194
V. SECRETORY GRANULES.....	168	IX. CORTICOTROPHIN: THE PROBLEM OF ITS ORIGIN.....	195
A. The Nature of Secretory Granules.....	168	A. Basophil Cells and Corticotrophin.....	195
B. The Staining Reactions of Secretory Granules by Modern Methods.....	169	B. Hypophyseal Responses to Adrenal Ablation.....	196
VI. CELL CLASSES AND CELL TYPES.....	171	C. Hypophyseal Responses to Stress.....	197
A. Classification.....	171	D. The Sixth Cell Type.....	198
B. Favorable Species.....	172	X. THE PARS INTERMEDIA AND INTERMEDIATE SECRETION.....	198
C. Reactivity.....	172	XI. THE PARS TUBERALIS.....	201
D. Specificity of Granules.....	173	XII. CYTOLOGIC CHANGES ACCOMPANYING SECRETORY RESPONSES CONCERNED WITH REPRODUCTIVE FUNCTION.....	201
E. Changes in Cell Proportions with Alteration in Function.....	173	A. Sexual Maturation in the Rat.....	201
VII. THE ACIDOPHIL CELL CLASS.....	174	B. Sexual Maturation in Other Animals.....	202
A. Acidophil Granules.....	174	C. Seasonal Breeding.....	202
B. Lipoid Content of Acidophil Granules.....	174	D. Induced Sexual Maturation in the Female Rat.....	202
C. Sulfhydryl and Disulfide Content of Acidophil Granules.....	175	E. The Active Breeding Phase in the Female.....	201
D. Hormone Content of Acidophil Cells.....	175	F. Pseudopregnancy and Pregnancy.....	201
E. Hormone Content of Acidophil Granules.....	176	G. Pregnancy Changes in the Human Hypophysis.....	201
F. Acidophil Cell Types.....	176		
G. Secretory Functions of Acidophil Cell Types.....	178		
H. Acidophil Cells in Relation to Somatotrophin Secretion.....	180		
VIII. THE BASOPHIL CELL CLASS.....	181		
A. Basophil Granules.....	181		
B. Hormone Content of Basophil Cells.....	183		

H. Lactation	205
XIII. THE HUMAN HYPOPHYSIS	206
A. Structure	206
B. Specific Basophil Types in the Human Hypophysis	206
C. Differential Staining of Basophil Cells in the Human Pars Distalis	207
D. Functions of the Basophil Cells of the Human Pars Distalis	209
1. The $\delta$ -cell	209
2. The blue $\beta$ -cell	209
3. The $\gamma$ -cell	209
E. The Amphophil Cells of Russfield	209
F. The Purple $\beta$ -Cell in the Cushing Syndrome	210
G. Crooke's Cell Changes Produced by Corticosteroid or Corticotrophin Administration	211
H. Changes in the Purple $\beta$ -Cells in Addison's Disease	212
I. The Pharyngeal Hypophysis	212
XIV. ELECTRON MICROSCOPY OF THE ADENOHYPHYSIS	212
A. Endoplasmic Reticulum	213
B. Golgi Region or Zone	213
C. Palade Granules	222
D. Secretory Granules	222
E. Microvilli	223
XV. THE NEUROHYPOPHYSIS AND NEUROHYPHYSEAL SECRETION	223
A. Neurosecretory Phenomena in the Hypothalamus and Neurohypophysis	223
B. The Chemical Nature of the Stainable Neurosecretory Material	227
C. The Physical Form of Neurosecretion in the Neurohypophysis: the Secretory Granule	227
D. The Hormone Content of Neurosecretory Granules	228
E. The Distribution of Oxytocin and Vasopressin	228
F. Inferences Concerning Rate of Secretion from Cytologic and Histochemical Studies	229
XVI. REFERENCES	229

## I. Introduction

The aim of this chapter is to present certain morphologic characteristics of the hypophysis. Emphasis is given to those aspects of the structure which are, in the light of modern knowledge, of importance in elucidating the functions of this organ. Although the study of morphologic features does not by itself provide clear answers to questions concerning the endocrine functions of the hypophysis, it is evident that the morphologic peculiarities of the gland are related to its functions, and that the consideration of morphologic data in conjunction with the

evidence derived from physiologic observations does assist in the construction of acceptable hypotheses concerning these functions.

## II. Embryonic Development

The adenohypophysis is derived from Rathke's pouch, a process of epithelial tissue derived from the buccal ectoderm. The distal portion of this process forms a hollow structure which lies in close contact with the infundibulum. The infundibulum is an outgrowth of neural tissue from the floor of the third ventricle, and differentiates into the neurohypophysis.

The work of Burch (1946) suggested that contact of the epithelial element with the neural element was necessary for the differentiation of the adenohypophysis from the former. He found in the frog (*Hyla regilla*) that translocation of the infundibulum or of the epithelial anlage, at a stage in development before these elements made contact, prevented the differentiation of the epithelial element. The pars intermedia did not develop, nor did acidophil and basophil cells appear in the epithelial cell mass. These results must, however, be reconsidered in view of the later findings of Etkin (1958). Etkin succeeded in transplanting the epithelial anlage at the earliest possible stage, and found that this does not prevent the differentiation of a pars intermedia. The development of normal pigmentation showed that the pars intermedia so differentiated functioned in its transplanted position and, in the later tadpole stages, pigmentation was greater than normal, indicating hyperfunction of the pars intermedia such as develops in the differentiated pars intermedia which is subsequently transplanted in the frog. Etkin's experiments were done with the wood frog, *Rana sylvatica*, but it is unlikely that the differences are due to species differences. Etkin observed differentiation of a pars distalis, but no chromophil cells were present at the stages examined. These chromophil cells usually do not appear until a later stage in normal animals. It has, therefore, not yet been demonstrated that a full differentiation of a functional pars distalis can occur without continued contact with the infundibulum.

It should be noted that Etkin's results do not show that contact with neural tissue is unnecessary for the initiation of the differentiation of the adenohypophysis from its epithelial anlage, because the buccal ectoderm is in contact with neural tissue before the development of either Rathke's pouch or the infundibulum. They do show, however, that the development of the adenohypophysis can proceed without continued contact with the neural element.

According to Eakin and Bush (1957), the pars nervosa develops without any consistent departure from normality in frogs (*Hyla regilla*) adenohypophysectomized at the limb-bud stage. Regeneration of a pars anterior often occurred giving albino tadpoles which metamorphosed normally. In one case a black nonmetamorphosing tadpole was found to have an adenohypophyseal fragment composed exclusively of cells similar to those of the normal pars intermedia.

The first appearance of granulated cells in the developing adenohypophysis presents some features of endocrinologic interest. Jost and Danyasz (1952) found glycoprotein granules in basophil cells in the rabbit fetus after 20 days gestation. In the rat (Jost and Tavernier, 1956) glycoprotein granules appear in the ventral portion of the pars anterior after 15 days and in the ventral portion after 17 days gestation. In both species the granules appear when the first evidence for gonadotrophin and thyrotrophin is observed.

In the human fetus basophil cell granules appear in the developing hypophysis much earlier than acidophil cell granules. Basophil cell granules are seen after 8 weeks gestation, whereas the first definite acidophil cell granules appear only at the 19- to 20-week stage (Pearse, 1953; Romeis, 1940). Romeis identified these early-appearing basophil cells as  $\beta$ -cells (purple  $\beta$ -cells) in the specific sense in which he uses this term. Inasmuch as intermedin appears in the human fetal hypophysis about the same time as these basophil cells (Keene and Hewer, 1924), it is possible that the  $\beta$ -cells of Romeis in the human hypophysis are intermedin-secreting cells and correspond to the cells of the pars intermedia of other mammals. More convincing evidence in support

of this hypothesis is presented in the section on the human hypophysis.

### III. Anatomic Subdivisions of the Hypophysis. Definition of Terms

The hypophysis is very variable in form in different vertebrates. Even among the mammals there is considerable variation. The comparative anatomy of the hypophysis has been reviewed by Romeis (1940), Green (1951), and Herlant (1954a). The nomenclature is in a state of considerable confusion and ill adapted to the needs of the comparative morphologist. Confusion arises from the great numbers of synonyms in use, the use as synonyms of terms that are not strictly synonymous, and the use of the same term for structures that are not strictly homologous.

Because of the importance of a rigid and consistent system of nomenclature, it seems advisable for the purpose of this chapter to adopt such a system and to use a single term for each structure, avoiding all use of synonyms except where it is necessary to quote from, or to refer in specific terms to, the publications of other authors. I shall make no attempt to list the various synonyms or near-synonyms in use, or to equate my usage with the varying usages which appear in past and current literature.

#### A. ANATOMIC DIVISIONS AND COMPONENTS

The mammalian hypophysis (and that of most terrestrial vertebrates) may be divided into three parts (Fig. 3.1). (1) The median eminence, forming the floor of the third ventricle of the brain and contiguous with the hypothalamus. (2) The hypophyseal stalk, an attenuated connection between the other two divisions. (3) The lobular hypophysis, an expanded structure enclosed in the pituitary fossa, the latter being a cavity or sac formed by dura and bone.

Each division consists of an adenohypophyseal component derived by way of Rathke's pouch from the buccal ectoderm and a neurohypophyseal component derived from the neural tissue in the floor of the third ventricle. These components will be named by the addition of prefixes to the names characterizing the three divisions; thus:

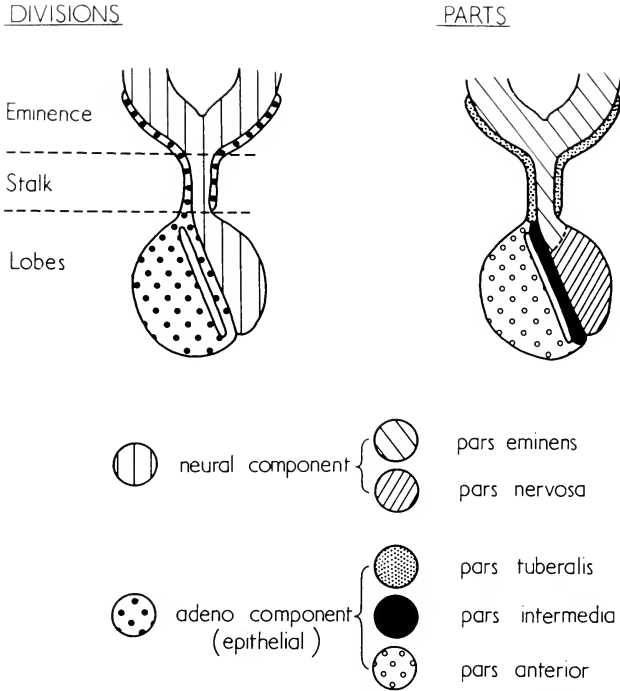

FIG. 3.1. Diagrams representing sagittal sections of a conventionalized mammalian hypophysis showing the divisions, components and parts. The adeno-eminence and adenostalk together form the pars tuberalis. The adenolobe is almost completely divided by the hypophysial cleft into an anterior lobe and an intermediate lobe. In many mammals the anterior lobe is entirely composed of pars anterior tissue and the intermediate is entirely composed of pars intermedia tissue as shown here. For further details refer to the text.

Adeno-eminence	Neural eminence
Adenostalk	Neural stalk
Adenolobe	Neural lobe

It must be added here that the division between eminence and stalk is in some species indefinite and cannot always be made; the stalk is variable in extent, and in some species it does not exist as a junctional region between the other divisions. Clearly the division into eminence and stalk is of descriptive value only and has no functional significance.

In most mammals, and in most other terrestrial vertebrates with the exception of birds, Rathke's pouch adheres to the neural component during development. The cavity of Rathke's pouch persists in the adult as a

flattened cavity—the hypophysial cleft (residual lumen)—which allows an easy separation of the adenolobe into two parts (Fig. 3.2). The portion of adenolobe which is adherent to the neural lobe is the intermediate lobe. The composite structure formed by the adherent neural and intermediate lobes is called the posterior lobe. The remaining portion of the adenolobe is the anterior lobe. Hypophysial hormones are commonly extracted from the separated anterior and posterior lobes. The anterior lobe hormones are somatotrophin, prolactin, corticotrophin, thyrotrophin, follicle-stimulating hormone (FSH), and luteinizing hormone (LH), and are the products of the pars anterior tissue which the anterior lobe contains. Posterior lobe hormones are intermedin, which derives



from the pars intermedia tissue in the intermediate lobe, and the neurohypophyseal hormones, oxytocin and vasopressin.

In whales (Wislocki and Geiling, 1936) and porpoises (Wislocki, 1929) and in the armadillo (Oldham, 1938), manatee (Oldham, McCleery and Geiling, 1938), elephant (Wislocki, 1939), pangolin (Herlant,

1954a), beaver (Kelsey, Sorensen, Hagen and Clausen, 1957), and the whole class of birds (DeLawder, Tarr and Geiling, 1934; Rahn and Painter, 1941), the cavity of Rathke's pouch is obliterated during development so that there is no hypophyseal cleft (Fig. 3.3). Moreover, in all these animals there is no adherence of the adenolobe to the

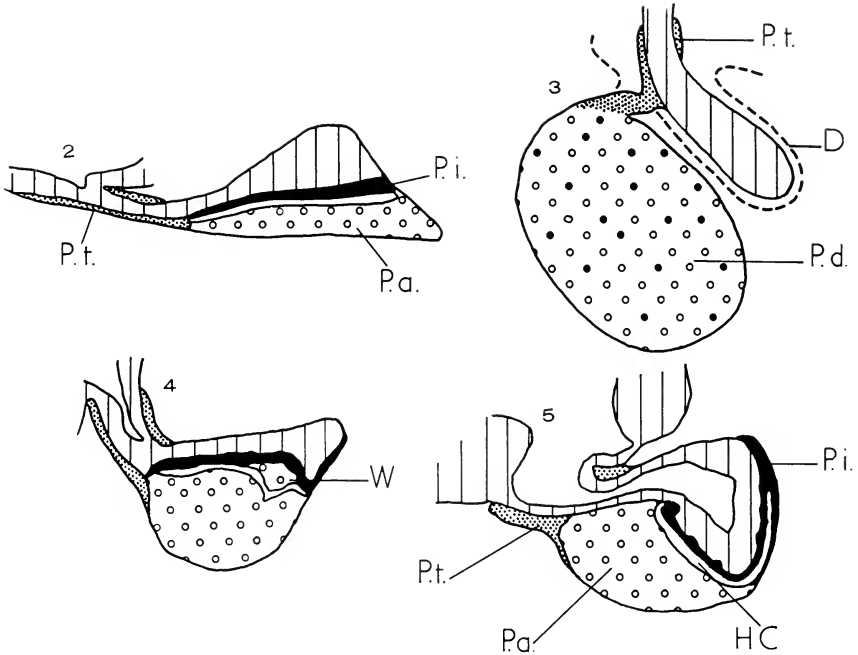

FIGS. 3.2, 3.3, 3.4, and 3.5. Diagrams of sagittal sections of the hypophyses of rat, cat, ox, and blue whale showing some of the variations encountered. The left side of the diagram is anterior, the right, posterior. (Modified from B. Romeis, in *Handbuch der mikroskopischen Anatomie des Menschen*, Vol. 6, Part 3, Julius Springer, Berlin, 1940.)

FIG. 3.2. The rat hypophysis is of the conventional form but rotated to bring the anterior lobe below and the posterior lobe above the axis of the gland.

FIG. 3.3. The hypophysis of the blue whale. In this form the adenolobe is not divided by a cleft and is not in close contact with the neural lobe, being separated from it by a fold of connective tissue (*D*) continuous with the dura. The adenolobe is filled with pars distalis tissue (P.d.) and the pars anterior (P.a.) of the pars anterior and the pars intermedia of the more usual mammalian form. In these respects the hypophyses of birds, porpoises, the armadillo, the elephant, the pangolin, and the beaver resemble the hypophysis of the whale.

FIG. 3.4. In the hypophysis of the ox the pars intermedia is less extensive than the intermediate lobe and the remainder of the intermediate lobe is occupied by typical pars anterior tissue. The segment of pars anterior tissue which is in the intermediate lobe and is separated from the bulk of the pars anterior by the hypophyseal cleft is known as the cone of Wulzen (Wulzen, 1914).

FIG. 3.5. In the cat hypophysis the neural lobe is deeply embedded in the adenolobe. Pars intermedia tissue occupies the entire intermediate lobe and extends into the anterior lobe particularly in the caudal region.

neural lobe, and these two structures can be easily separated from one another. This is not a separation into anterior lobe and posterior lobe, which terms are not applicable to this type of hypophysis.

The relation between the adenolobe and neural lobe in man is unique and is described in the section on the human hypophysis.

### 3. HISTOLOGIC DIVISIONS OF THE HYPOPHYSIS: FUNCTIONAL PARTS

For the purpose of correlating structure with function, it is necessary to separate the hypophysis into parts on the basis of internal structure or of function, a separation independent of variations in gross anatomy. It matters not in theory whether the separation is based on fine structure or on function, because one determines the other. In practice the exact delimitation of the functional partition is determined by methods which are histologic or cytologic. For the determination of the homology between the histologically distinct parts of the hypophysis in different species, function must be the determining criterion. Histologically distinctive parts in different species can be considered homologous and be given the same name only if they are equivalent in function. Nature has set a trap for those who are careless in this respect. The partition of the adenohypophysis into functional parts is variable.

In terrestrial vertebrates the neurohypophysis consists of two functionally distinct parts (Green, 1951). Although following Green in this partition of the neurohypophysis, I must, however, reject his terminology, which used the anatomic terms "median eminence" and "neural lobe" in a modified sense. I propose, therefore, to use for these parts the names "*pars eminentis*" and "*pars nervosa*."

The two parts of the neurohypophysis are: (1) *Pars eminentis*—consists of the neural eminence and neural stalk and the continuation of this tissue in the neural lobe to the point where it becomes the *pars nervosa*. Characterized by a vascularization in common with the adenohypophysis. Its venous effluents form portal vessels which pass into and are the main blood supply of the *pars anterior* or the *pars distalis* of the adenohy-

pophysis. (2) *Pars nervosa*—that part of the neural lobe whose venous effluent passes to the systemic veins directly.

There are two other differences between the *pars eminentis* and the *pars nervosa* which characterize them. First, the arteries and veins of the *pars eminentis* are confined entirely to the surface, where they connect with a rich vascular network. The interior of the *pars eminentis* is relatively sparsely supplied with capillary loops—simple hair-pin loops in small animals, more complex vascular spikes in larger animals—which penetrate it from the surface network. In contrast, the arteries and veins of the *pars nervosa* ramify within its substance and connect with a capillary network of the usual form. Second, in histologic sections the *pars eminentis* is characterized by a low content, the *pars nervosa* by a high content, of stainable neurohypophysial secretion.

In most mammals, and in most other terrestrial vertebrates except birds, the parts of the adenohypophysis (usual form) are three. (1) *Pars tuberalis*—consists of the adeno-eminence and adenostalk. Continues distally with the *pars anterior*, from which it is distinguished by the absence of the chromophil cells which characterize the latter. (2) *Pars intermedia*—a part of the adenolobe adjacent to and adherent to the neural lobe. Histologically it is characterized by the presence of cells of uniform appearance. These contain basophil granules, in quantities that vary greatly in different species. In some species granules appear to be absent. Functionally the *pars intermedia* is characterized by the presence of intermedin and of no other known hormone. The *pars intermedia* in some species is co-extensive with the intermediate lobe. In some, e.g., the sheep and the cow (Fig. 3.4), it is less extensive than the intermediate lobe, and the remainder of this lobe consists of *pars anterior* tissue (Wulzen, 1914). Such a detached portion of the *pars anterior* is known as a cone of Wulzen. In some species, such as the cat (Fig. 3.5), the *pars intermedia* is more extensive than the intermediate lobe, and extends somewhat into the anterior lobe. (3) *Pars anterior*—this tissue occupies the part of the adenolobe which is not *pars intermedia*. It is characterized by

the presence of a mixed cell population including several types of chromophil cells.

In man, whales, porpoises, armadillo, manatee, elephant, pangolin, beaver, and in the whole class of birds, there is no pars intermedia (Fig. 3.3). The adenolobe contains throughout a mixed population of cells resembling that of the pars anterior. This structure differs from the pars anterior in containing intermedin in addition to the anterior lobe hormones, and in all probability contains an additional cell type corresponding to the pars intermedia cells. This structure I will call pars distalis to indicate that it is not strictly homologous with the pars anterior as previously defined (Geiling, 1935). In these species, therefore, the parts of the hypophysis are two: (1) Pars tuberalis—as in other species. (2) Pars distalis—the whole adenolobe containing a mixed cell population throughout its extent.

It may be noted here that, although in mammals the absence of a pars intermedia is correlated with the absence of the hypophyseal cleft, in lower vertebrates a pars intermedia may be present despite the absence of the cleft (Green, 1951).

#### C. ZONES IN THE PARS ANTERIOR AND PARS DISTALIS

The different cell types in the pars anterior or pars distalis are not uniformly distributed. The inequalities in the distribution of the acidophil cells, although not more marked than those of other cell types, are more conspicuous because of the larger number of these cells and their conspicuous staining. Zones rich in acidophil cells are called acidophil zones, zones poor in acidophil cells are called basophil zones. The zona tuberalis in the pars anterior adjacent to the junction of the latter with the pars tuberalis is a basophil zone.

This zonation, seen in many pituitaries, aids in the distinction between specific cell types and functional variants. When two cell groups with different stainability are shown to have different distributions characteristic for each, the groups so differentiated may be accepted as types. When there is no difference in the distribution of cells with minor differences in coloration, etc., the possibility remains that these different

appearances are those of a single cell type in different functional states.

#### IV. A General Statement of the Problems of the Special Cytology of the Hypophysis

Nine distinct hormones are secreted by the hypophysis. Some simplification of the problem of relating the secretion of each hormone to specific cytologic details results from the fact that 2 of these hormones are secreted from the neurohypophysis and 1 from the pars intermedia, leaving only 6 to be secreted from the pars anterior. A complete revolution in the physiology of neurohypophysis has recently resulted from the discovery of methods for staining neurosecretion in this structure. It is indeed a source of wonder and delight that so much new and fascinating knowledge should result from the application of a simple technical discovery. The last 20 years have also seen great advances in the cytology of the pars anterior. Indeed, the progress here can be claimed to be more extensive, if less spectacular, than in the neurohypophysis. For all this the author, constrained to review the comparative cytology of the pars anterior, approaches his task with foreboding. A peculiar difficulty arises here which is not encountered in the neurohypophysis. The staining reactions of the granules of functionally equivalent cells are not consistent from species to species. This variation is easily understandable. The hormones themselves vary in chemical composition from species to species, even to the extent of the hormone from one mammalian species being inactive in another species. The secretory granules of pars anterior cells contain the hormones in association with hormonally inactive proteins no less variable than the hormones themselves. Functionally equivalent cells in different species may therefore have no specific component common to both despite the fact that they serve an identical function in the two species.

In this situation generalizations concerning the cytology of the pars anterior are difficult and hazardous. The treatment of the subject given here seems to be consistent with the recorded observations in a number of species. Without doubt further investi-

tion, especially in additional species, will reveal its inadequacies.

## V. Secretory Granules

### A. THE NATURE OF SECRETORY GRANULES

Many of the cells of the pars anterior contain characteristic secretion granules stainable by a variety of procedures which indicate that the granules are composed mainly of characteristic proteins. The secretion of the different hormones is intimately related to the formation and discharge of secretory granules in different cells, and the nature of the hormone secreted by any cell is intimately related to the chemical nature of the secretory granules in that cell. The special cytology of the hypophysis, which deals with the differences between cells with different functions, is practically confined to the study of the secretory granules, these being the only truly specific characters that can be made visible by current techniques.

Granules similar to those in the cells of the pars anterior are seen in other tissues where the cells secrete proteins which act as hormones or enzymes. Examples are the granules of the hormone-secreting  $\alpha$ - and  $\beta$ -cells of the pancreatic islets, and the zymogen granules of the enzyme-secreting acinar cells of the pancreatic parenchyma. The nature of zymogen granules of the pancreas and the relationship of the granule to the secretory process have been clarified by the epoch-making researches of Palade (1956), and of Sicevitz and Palade (1958a, b).

As seen in electron micrographs, the zymogen granules in the guinea pig pancreas are spherical bodies about 600 m $\mu$  in diameter. At certain stages in their formation a smooth membrane becomes visible at the periphery. It may be assumed that zymogen granules are bound by a smooth-surfaced membrane throughout their intracellular existence, and that, when in the fully formed granule an enclosing membrane is not visible in electron micrographs, it is because it is closely applied to the homogeneous content of equally high density.

Secretion of zymogen into the ducts after feeding the previously fasted guinea pig results in the disappearance of membrane-en-

closed granules from the apical pole of the cell and the appearance of the dense content of the granule without enclosing membranes in the lumen of the duct. Apparently the enclosing membranes are left behind at the cell border and therefore presumably coalesce with the cell membrane during the passage of the granule through this structure.

Restoration of the cell content of enzymes and enzyme precursors occurs rapidly after secretory discharge. These products are formed in the basal part of the cell in which the synthesizing system is located. This system is revealed in electron micrographs as a closely packed arrangement of rough-surfaced membranes forming part of the endoplasmic reticulum. In light microscopy it is revealed by the cytoplasmic basophilia due to the ribonucleic acid component of the system. It is especially to be noted that the formation of the secretory product is not accompanied by any formation of membrane-enclosed zymogen granules, but dense material in a more or less diffuse form appears in the cavities of the endoplasmic reticulum. The filling of relatively large vesicles in the Golgi zone with dense material and the accumulation of membrane-enclosed zymogen granules in the apical region of the cell occur relatively late in the secretory cycle and seem to result from intracellular transport and enclosure in membranes of products synthesized earlier in the basal region.

One implication of these observations is that a hormone could be formed and released by an endocrine cell without being stored in the form of granules. This is possible inasmuch as the granule does not play any part in the formation of the secretion.

Electron microscopy of the rat hypophysis indicates that the granules are similar in structure to zymogen granules of the pancreas. The enclosing membrane is easily visible in the basophil granules of the pars anterior and in the neurosecretory granules of the pars nervosa as an electron-dense membrane enclosing a less dense content. The acidophil granules of pars anterior cells, like the zymogen granules of the pancreas, seem to contain solid protein of a density that does not permit the demonstration of an enclosing membrane except in

those granules that are only partially filled (Farquhar and Wellings, 1957).

There is no necessity for secretory granules to contain a single substance. The zymogen granules of the pancreas contain a mixture of enzymes and enzyme precursors. It is certain that some granules in the hypophysis contain a mixture of materials, some hormonal and others not hormonal. The staining reactions of specific granules may therefore be due to a nonhormonal constituent. This seems to be true of acidophil granules in the pituitary, inasmuch as the characteristic staining is due to a protein which is highly insoluble over a wide range of pH, whereas the hormones characteristic of these cells, growth and lactogenic hormone, are more soluble and can be extracted by procedures which do not dissolve the characteristic protein. Similar considerations apply to the neurosecretion in the nerve fibers of the neural lobe, because the characteristic hormones are octapeptides, whereas the characteristic staining is due to a protein with high cystine content presumably identical with the van Dyke protein (van Dyke, Chow, Greep and Rothen, 1942). The granules of basophil cells contain glycoprotein, and the characteristic staining reactions seem to be due to the glycoproteins because they are similar to the staining reaction seen in other sites containing glycoprotein. In the basophil cells, however, it is not known whether the glycoproteins responsible for the staining reactions are identical with the hormones or whether they exist in the vesicular glands in association with hormonally active molecules themselves not stainable or not made visible by staining reactions because of their low concentration. Parallelism between intensity of staining and hormone content, which has been used to support the claim that it is the hormone product itself of these cells which is stained, does not in fact contribute to the solution of this problem. Staining reactions demonstrate the numbers of granules present, and parallelism between staining and hormone content indicates that the hormone is likewise contained within the granule. Chemical investigation of the nature of the isolated hormones and of the protein materials responsible for the staining reactions is the only source of evidence which might show

that the staining reactions are due to a product distinct from the hormonally active product. This may be regarded as established for acidophil cell granules, neurosecretory granules, and for the glycoprotein granules of the pars intermedia cells, but has not been established for glycoprotein-containing cells of the basophil cells of the pars anterior. In this site, therefore, it is still possible that the staining reactions are due to the hormonally active product itself and not to any associated but hormonally inactive protein.

#### B. THE STAINING REACTIONS OF SECRETORY GRANULES BY MODERN METHODS

The recognition of a diversity of cell types in the pars distalis as reported by Schönemann (1892) depends on the presence of distinctive proteins in different cells. Although at one time theories which made the different cell types stages of a secretory cycle had a certain popularity, we now know that the different cell types made visible by staining methods have different secretory functions. This was first demonstrated by the observations of Smith and Smith (1923a, b). This momentous experiment showed a diversity of endocrine function in the anterior lobe and a correlation between function and type of cell. It also destroyed the hypothesis that different cell types could be merely different phases of a secretory cycle. All these results followed from the demonstration that in the bovine hypophysis there is constantly present a zone situated anteromedially which is poor in acidophil cells and, therefore, is mainly comprised of basophil cells and chromophobes. The tissue from this zone implanted into tadpoles had a predominantly thyroid-stimulating and consequent metamorphosis-inducing effect, whereas tissue rich in acidophils promoted body growth and was poor in thyroid-stimulating action. It is clear, then, that staining reactions in pituitary cells may be related to the nature of the hormone produced, and we may, therefore, consider in what manner the staining reactions are linked to the specific function. Although it is reasonable to assume that differences in the product of different cells arise from variations in the enzyme content, the slight differences in

the enzymes which would produce these effects are not, with present techniques, demonstrable by staining reactions. It is therefore not possible at present to stain different cell types in the pituitary, if by this phrase we mean the demonstration of differences in the cytoplasmic make-up of cells with different secretory functions. Differences in staining, which are observed with more or less ease, are due to the staining reactions of the products of hormone synthesis within the cell; they do not demonstrate differences in the synthesizing mechanisms directly. One consequence of this is that specific cell types are only differentiated when there is, within their cytoplasm, an adequate amount of their specific product in the form of granules.

Specific staining of granules requires methods which stain granules while leaving other cytoplasmic components unstained. Simple basic dyes such as methylene blue are not useful for this purpose. The basophilia of the basophil granules is weak, the binding power is weaker than that of ribonucleic acid. The capacity for dye absorption is great at high pH, so that cells with heavy accumulations of basophil granules appear densely stained, and it is this density of staining in densely granulated cells, rather than any exceptional strength of binding, that justifies the use of the term basophil for a certain class of cells in the adenohypophysis (Peterson and Weiss, 1955). Simple acid dyes do stain certain secretory granules specifically and find a use as counterstains to other procedures.

Modern methods of staining allow clear-cut differentiations of specific granules by methods that do not depend on the distinction between acidophilia and basophilia.

The results of histochemical procedures may be expected to show a more consistent relation to function than the results of empiric staining methods. The McManus (1946) periodic-acid Schiff (PAS) reaction, which under certain conditions is specific for protein-carbohydrate complexes in sections of animal tissues, allows a partition of the granules into two classes, which may have a consistent functional significance. An intense red or magenta color produced by this procedure in certain granules indicates that they contain glycoprotein. These

glycoprotein-containing granules are basophil granules, showing the same characteristic basophilia wherever they occur in all cells of all species. Their staining reactions to acid dyes are, however, variable. The PAS reaction can be combined with counterstains which demonstrate the granules composed of simple proteins. The latter granules are acidophil granules.

Inasmuch as both the acidophil class and basophil class are composite, additional methods must be applied to effect a further separation of each class. Methods of general usefulness for this purpose are: (1) Staining by a mixture of acid dyes in such methods as Heidenhain's azan or Crossmon's (1937) modification of Mallory's stain. Granules may be stained orange, red, or blue, or a purple color from a mixture of red and blue dye. The coloration in each case depends on *acidophilia*; it has no relation to basophilia. The varying colors depend on variations in the strength and the quality of the acidophilia. Acidophil granules, like other strongly acidophilic structures, are stained either orange or red. Basophil granules may be orange, red, purple, or blue. (2) The use of elastic tissue stains such as kresofuchsin, resorcin-fuchsin, or Gomori's (1950) aldehyde-fuchsin, of which only the latter is in present-day use as a stain for hypophyseal granules. With these stains it is possible to stain some basophil (glycoprotein) granules while leaving others unstained.

By combining the results of the above methods of staining, at least 10 distinctly different staining reactions have been observed in specific granulation in the adenohypophyses of vertebrates. To date, however, no more than 4, or possibly 5, distinct staining reactions have been observed in the pars anterior of any one species. There is no possibility, therefore, of any constant relationship between staining and function.

Before progressing to the subject of cell classes and cell types, the problem presented by the existence of cytoplasmic ribonucleic acid should be discussed. Ribonucleic acid occurs in the cytoplasm of acidophils and basophils. It is a component of the Palade granules (Palade, 1955) which are described in the section on electron microscopy of the adenohypophysis. These

granules are quite distinct from the secretory granules.

At one time the basophilia of basophil granules was ascribed to ribonucleic acid. It is now clear both from electron microscopy and from specific staining responses that cells of the basophil class generally contain less cytoplasmic ribonucleic acid than do acidophil cells and that ribonucleic acid is not a constituent of basophil granules.

The cytoplasmic basophilia demonstrated by the red staining by pyronin in the pyronin-methyl-green stain shows an entirely different distribution from the basophilia revealed by neutral toluidine blue or by the Gram stain and it appears probable that this pyronin-staining is specific for cytoplasmic ribonucleic acid. Pyronin basophilia is observed in all classes of cells of the anterior lobe and is increased in conditions where rapid secretion rather than storage is thought to be taking place. It is notably increased in the large degranulated cells observed in the hypophysis of pregnant animals and in animals treated by estrogen (Herlant, 1943).

Treatment for a short time with a ribonuclease preparation will remove the pyronin basophilia without removing the Gram-positive reaction or the violet metachromasia with toluidine blue in the basophil granules (Foster and Wilson, 1951; Pearse, 1952). Prolonged exposure to bile salts (Foster and Wilson, 1951) or ribonuclease preparations (Pearse, 1952) will remove the basophilia of the basophil granules, as well as the cytoplasmic basophilia. This does not indicate that the basophilia of the basophil granules is due to ribonucleic acid. Pearse (1952) has demonstrated the absence of ribonucleic acid in specific basophil granules by means of the coupled tetrazonium reaction. Acetylation for 8 hours blocks the reaction in the basophil granules but does not block the reaction of nucleolic and cytoplasm.

## VI. Cell Classes and Cell Types

### A. CLASSIFICATION

Present knowledge has diminished somewhat the number of distinct adenohypophyseal hormones, and it seems possible

that no more than six may have to be accommodated in the pars anterior. These are somatotrophin or the growth hormone, prolactin or the lactogenic hormone, corticotrophin, thyrotrophin, FSH, and LH. It seems probable from recent developments that six cell types may be present in the pars anterior. It is, therefore, profitable to discuss pituitary cytology and its relation to pituitary function on the assumption that each hormone may be the single product of a specific cell type. This may, or may not, be true; a system of classification must not be too rigid.

The differentiation of the cells of the anterior pituitary into acidophils, basophils, and chromophobes must be regarded as a differentiation of an unknown number of specific cell types into three classes.

The cells are classified by, and take their names from, the staining reactions of their specific granules. Even the smallest detectable amount of granulation serves for this purpose, provided there is no confusion with mitochondria or cytoplasmic basophilia.

It may be noted here that it is usual to say that cells are stained by a reagent when they contain a large number of uniformly distributed stained granules. This usage is dangerous unless the convention is adopted and rigidly adhered to that all staining reactions of cells, unless explicitly stated to be otherwise, refer to the staining of specific granulation. It is particularly important when recording the absence of staining to note and state if there are granules that are unstained by the reagent. An absence of staining when there is an absence of granules is not at all of the same significance. The failure to differentiate between the staining of granules and the staining of other cytoplasmic components is a common error.

Cell types of the acidophil class contain specific granules which have similar properties and, therefore, react alike to the cruder staining methods. In the same way the specific granulation of the cell types of the basophil class have certain properties in common which are to be ascribed to a similarity in the chemical nature of the secretions which enable them to be recognized as a distinctive class. Chromophobic cells which lack specific granulations of either

the acidophil or basophil cell classes will include all cells in a resting or inactive phase which temporarily do not contain specific granulation, and will also include any specific chromophobe type of cell which does not contain stainable granules at any time.

The characteristic of the acidophil cells is that they contain specific granules which are of a solid protein nature of high insolubility, easily preserved by any method of fixation. These acidophil granules have a strong affinity for acid dyes of all sorts, their degree of acidophilia being somewhat less than that of the hemoglobin of the red blood corpuscles. The cells of the basophil class are characterized by the presence of specific granulation in the form of droplets of glycoprotein which are not highly refractile and whose contents are freely soluble at physiological pH. Their retention in the cell depends on the impermeability of the membranes, and they are released or dissolved when the cytoplasmic integrity is destroyed by cytolytic agents. The glycoproteins of the basophil cells have affinities for acid dyes which vary among the specific types in any one species and also from species to species. For a rigid division of chromophil cells into the acidophil and basophil classes, appeal must be made to an investigation of the chemical nature of the granulation by the PAS reaction. The subsequent subdivision of these classes into specific cell types is at present only partially achieved by tinctorial methods, and then only in favorable cases. It depends on empiric staining procedures, the results of which are not consistent from species to species.

#### B. FAVORABLE SPECIES

The first feature that would be noticed by anyone who applied standardized staining procedures to pituitaries of a number of mammalian species would be the greatly differing results obtained. These differences depend not only on the relative proportions of the different cell types, but also on the intensity of coloration and quality of the staining reaction. Thus some mammalian species provide pituitaries whose anterior lobes do not at first sight appear promising, because basophil cells occur only in small

numbers and with weak staining reactions not conducive to their differentiation into specific types. Acidophil cells may seem to be all of one type and all give the same staining reactions, either because only one type is present, or because two types are present but with staining reactions too close to be separated by the standardized arbitrary procedure used. Other species provide pituitaries which, from the first inspection, show themselves favorable for detailed study in that a wider variety of different cell types with strong and distinctive staining reactions is revealed.

Examples of mammalian pituitaries with staining properties favorable to the differentiation of the specific types are those of the bat (Herlant, 1956a), dog (Purves and Griesbach, 1957a), monkey (Dawson, 1954b), and cat (Herlant and Raeadot, 1957). In these species the presence of five distinctive cell types in the pars distalis can be inferred from the results of the staining procedures. In other species the number of cell types is presumably similar, but the staining reactions of the granules are less favorable for the purposes of tinctorial differentiation.

#### C. REACTIVITY

In species whose pars anterior cells contain granules with favorable staining reactions, subsequent experimentation will show whether the cell types so revealed will favor the experimenter by marked variations in their appearances in correlation with changes in their secretory activity. In some species the variations in appearance, in conditions producing widely different levels of secretion of specific hormones, are so small and inconspicuous that much time and careful measurement may be necessary to detect the morphologic equivalent of the secretory change. In other species the most striking alterations of cell size, contour, and granule content occur as accompaniments of changes of secretion rate, including the appearance of new forms and substances which are rarely to be seen in the "normal" pituitary. Examples of such changes are the appearance of thyroidectomy cells and castration cells in the rat pituitary under conditions producing rapid secretion of thyrotrophin or gonadotrophins respectively.



Reactivity in this sense, by enabling the significance of tinctorial or morphologic differences to be tested, is of primary importance both in the verification of partitions based on tinctorial or morphologic differences and in the identification of cell types as secretors of specific hormones. Only those differences which are correlated with a difference in reactivity, and which can be related to the production of specific hormones, can be regarded as of specific significance. Variations in the size and shape of the cell or its nucleus, the amount of cytoplasmic basophilia, the form of the Golgi apparatus, and the amount of granulation may be related to variations in the state of activity in the single cell type and are, therefore, of functional significance but not of specific value.

#### D. SPECIFICITY OF GRANULES

One implication of the method of classification formulated here is that all the secretory granules within any one cell will be of a single type. This seems to be true of the majority of mammals, judging from my own observations. Admittedly it is possible with some techniques to obtain different colors in granules in the one cell, just as it is possible to stain erythrocytes two different colors in the one blood vessel, but such color differences are not significant. Apart from this, there is the possibility, since secretory granules in general contain a mixture of proteins and peptides and not a single substance, that granules vary in quality, due to differing proportions of the several components at different times as a result of different rates of secretion or from other effects. If this is so, differing shades of color may be obtained with some procedures in granules containing the same hormone.

#### E. CHANGES IN CELL PROPORTIONS WITH ALTERATIONS IN FUNCTION

The modifications in secretory activity, which occur as the result of environmental influences, or after experimental intervention, produce in some species distinct differences in the appearances of stained sections of the pars anterior. These differences are often referred to as "changes in the proportions of chromophil cells." Since in

many instances such changes in the proportions of different cell types occur rapidly and without any proportionate number of mitoses, changes in the proportions of cells have, in the past, been ascribed to the transformation of cells of one type into cells of another type. It cannot be said as yet that transformation of one cell type to another does not occur, but, if it does, it must be limited. The impossibility of telling what appearance any given cell would have shown at some time other than the time at which it was taken from the animal precludes a direct examination of transformations. The zonation phenomenon, however, is of the greatest assistance in setting limits to transformations that may occur. The stability of the acidophil and basophil zones in certain mammals shows that basophil cells and the chromophobes of the basophil zone are not transformable into acidophils, nor are acidophils transformable into basophils. Moreover, the fact that the anterior lobe hormones have been shown in some species to be not uniformly distributed within the anterior lobe, but to have characteristic distributions, different for the different hormones, suggests that each hormone is the product of a specific cell type not transformable into cells with a different function.

If, therefore, basophils cannot be transformed into acidophils or acidophils into basophils, if for the most part each hormone is produced by its own specific cell type which is not transformable into another type with a different function, how can the apparent difference in the proportions of acidophils, basophils, and chromophobes be explained? Three effects are operative. First, in many species a large proportion of the cells of the pars anterior are classified as chromophobes. Most of these cells are cells in a temporarily inactive phase and contain either no specific granulation or granulation in amounts too small to give decided staining reactions. With an alteration in secretion rate large numbers of chromophobe cells may accumulate granules. The transformation, however, is only from a specific cell low in granule content to one with high granule content, and not the production of a specific cell type from an undifferentiated cell. Second, the size of individual cells

greatly influences the proportionate count obtained from the examination of thin sections. The larger cells not only show a greater area of cross section in the sections in which they appear, but they also appear more frequently owing to their greater extension in the direction perpendicular to the plane of section. The third effect, which is also related to the size of the cell as well as to its granule content, is the ease of recognition. When the cytoplasm is scanty the true nature of the cell may be missed and it may be classed as a chromophobe, whereas with equal granule density but with an increased width of cytoplasm it would be classed as a chromophil. These three effects are responsible for most of the variations in cell proportions reported in experimental studies of the pars distalis.

It should be noted here that, although marked variations in apparent cell proportions occur in some species, the hypophyses of other species are remarkably uniform in appearance despite extreme variation in secretory function. Thus the bovine hypophysis shows little change in response to thyroxine deficiency, thyroxine administration, castration, or administration of sex hormones. The tendency for experimental work to be concentrated on those species in which functional changes are accompanied by marked cytologic changes has obscured the fact that such obvious cytologic changes are not a necessary accompaniment to changes in a secretion rate.

## VII. The Acidophil Cell Class

### A. ACIDOPHIL GRANULES

Acidophil granules consist of a membrane enclosing solid contents. The presence of the membrane has been demonstrated by electron microscopy (Farquhar and Wellings, 1957). The contents include an insoluble protein, phospholipid, and hormones.

In size acidophil granules range from 0.1 to about 1.0  $\mu$ . In species where two types of acidophil cells can be seen, it is usual for the granules in one type to have a larger average size than those in the other. In species with large granules, the fact that there is a variation of size in the granules within individual cells can be determined with the light microscope. The granule size varies

with the species, being relatively large in man, dogs, and cats, but fine in guinea pigs, mice, and sheep.

The acidophil granules are highly refractile in the fresh state. In living cells, under dark-ground examination, they are seen to be in constant rapid motion and show a refractility and luminosity greater than that of any element in basophil or chromophil cells. Their high refractility is a consequence of their solid nature. In typical acidophil cells a high concentration of granules is present in the cytoplasm, and this confers on acidophil-containing areas an opacity which enables them to be distinguished in the fresh state from zones in which acidophil cells are absent (Smith and Smith, 1923b).

In rats, almost total degranulation of the acidophil cells follows complete thyroxine deficiency, and in such hypophyses the normal opaque appearance of the anterior lobe changes to the translucent semitransparent appearance normally seen in the acidophil-free areas of the bovine hypophysis (Purves and Griesbach, 1946).

Acidophil granules are quite different from mitochondria. Specific staining methods for the demonstration of mitochondria leave the granules unstained (Severinghaus, 1932; 1939). When what may be termed ordinary methods of fixation and staining are used, the staining reactions of mitochondria and acidophil granules are similar.

The acidophil granules, like mitochondria, are readily released when the cells are disrupted in water, saline solutions, or sucrose solutions. In suspension they have the appearance of spherical highly refractile bodies of varying size. They have a higher density than any other element, but sediment more slowly than nuclei and erythrocytes because of their smaller size. On prolonged centrifugation acidophil granules make their way through the layer of nuclei and erythrocytes and appear on the bottom of the centrifuge tube. They differ from mitochondria in not swelling up and disintegrating in saline solutions or distilled water, and in not collapsing on drying.

### B. LIPOID CONTENT OF ACIDOPHIL GRANULES

The acidophil granules isolated by centrifugation (Herlant, 1952a) are positively

stained by the Baker acid hematein test for phospholipid. In sections the same test produces a dark coloration of acidophil cells which is attributable to, in the main, staining of the granules (Rennels, 1953). There is some conflict of opinion as to whether this staining indicates the presence of phospholipid or is the result of some property of the granule protein. Herlant (1952a) and Elftman (1956) consider the reaction not to indicate phospholipid, but the evidence on which this conclusion is based is contradictory to the observations of Racadot (1954) and Ortman (1956). The value of the hematein staining as a specific stain for acidophil granules is diminished by the positive staining of mitochondria and of phospholipid and other materials in basophil cells.

#### C. SULFHYDRYL AND DISULFIDE CONTENT OF ACIDOPHIL GRANULES

Ladman and Barnett (1954) described the staining of acidophil cells in the rat by the Barnett-Seligman technique which is presumed to be specific for sulfhydryl and disulfide groups. This staining in acidophil cells is obtained only after fixation in Zenker's fluid. After fixation in acid alcohol and a number of other fixatives the cells do not stain. This observation could be interpreted to indicate the presence in acidophil granules of a sulfur-rich protein soluble in acid alcohol and preserved only by fixation in Zenker's fluid. Because of the possibility of formation of mercury compounds by the action of the fixative, and because such compounds might also react with the reagent used to demonstrate sulfhydryl groups, these results should be interpreted with caution. An increased staining after Zenker fixation, in comparison with acid alcohol fixation, is common to many animal tissues (Barnett, 1953; Barnett and Seligman, 1954). It has not been shown that treatment with Zenker's fluid after previous fixation in acid alcohol does not induce this type of staining. Adams and Swettenham (1958) showed that staining of the acidophil granules in the human pars distalis by the Barnett-Seligman reaction was not due to cystine, because it was not blocked by oxidation of the sulfide linkages to sulfonic acid groups by performic acid. It should also be noted that the acidophil granules did

not react positively to other histochemical tests for cystine.

#### D. HORMONE CONTENT OF ACIDOPHIL CELLS

An indication of the probable nature of the hormonal secretions of cells of the acidophil class is obtainable from the assay of portions of the acidophil and basophil zones of the pars anterior. Experiments of this sort were first made by Smith and Smith (1923a, b), who found that the central basophil zone of the bovine pituitary stimulated metamorphosis in hypophysectomized tadpoles with accompanying stimulation of the thyroid gland; the outer acidophil-rich portions caused an unusual stimulation of growth without causing either metamorphosis or activation of the thyroid. These results indicate the probability that growth hormone is present in high concentration in parts of the gland which are rich in acidophil cells. Azimov and Altman (1938) and Friedman and Hall (1941) found a differential concentration of prolactin in the peripheral acidophilic zones of the bovine hypophysis.

The problem of the distribution of the corticotrophin in the predominantly acidophilic and basophilic zones was apparently decided by the consistent results obtained by Smelser (1944) and Giroud and Martinet (1948), who found that the adrenal weight-increasing action was predominantly situated in the basophil zone. Later discoveries concerning the unreliability of the adrenal weight increase as a measure of adreno-corticotrophic activity made these results of less significance than was formerly believed. Some observations suggested that the adreno-corticotrophic hormone may, in fact, be present in high concentration in the acidophil zone. Chiti and Zinolli (1952) found that both the acidophilic and basophilic zones of the pig hypophysis have an action on the guinea pig adrenal cortex, and that there is a difference in the response to the two zones. The response to the basophilic zone was more marked in the fasciculata of the adrenal cortex, whereas the tissue of the acidophilic zone caused an enlargement of the reticularis. Desclaux, Souclairac and Chaneac (1953) using beef pituitaries found that implants of the basophil zone placed in contact with the adrenal of the rat did not block

ify the lipid content of the adjacent adrenal cortex, whereas similar implants from the acidophilic zone produced a discharge of lipid followed by a re-accumulation. The response, therefore, to the local presence of tissue from the acidophilic zone was similar to that produced by injections of corticotrophin. Inasmuch as Halmi and Bogdanove (1951) have shown that rat pituitaries which have lost their acidophil granules after total thyroidectomy still contain normal amounts of corticotrophin, it would seem that corticotrophin is not a constituent of the acidophil granules in the rat.

My own assays of the basophil and acidophil zones of the pig pars anterior, using the ascorbic acid depletion assay, showed that both zones contained high concentrations of corticotrophin, but that there was a higher concentration in the basophil zone than in the acidophil zone. In this species, as in the rat and bovine, corticotrophin is not associated with acidophil granules, and although a different situation may be found in other species, I would ascribe Herlant's (1952b, 1953a) results to the absorption of the hormone by the granules or other particles sedimenting with them. The results of implantation experiments are explicable by the fact that corticotrophin is present in acidophil and basophil zones in about the same amount; apparently the histologic response is modified by the presence of other materials, different for each zone.

Inasmuch as somatotrophin and prolactin are the two hormones which are in higher concentration in the acidophil zones of pig and beef anterior lobes, it is concluded that these hormones are in the acidophil cells. The two hormones are not necessarily produced in the same cell, because in many mammals two types of acidophil cells can be seen. Purves and Sirett (1959) have shown that prolactin and somatotrophin have different distributions in the anterior lobe of the wallaby hypophysis, indicating a separate origin for each hormone.

#### E. HORMONE CONTENT OF ACIDOPHIL GRANULES

Acidophil granules prepared by the differential centrifugation of the suspension prepared by disintegrating the anterior lobes of sheep, pig, and bovine hypophyses in hyper-

tonic sucrose solution, were examined for their hormone content by Herlant (1952a, b; 1955). The easily sedimented granules contain prolactin and somatotrophin, whereas thyrotrophin and gonadotrophins remain in the supernatant, from which they can be thrown down only by centrifuging at much higher speeds. The granules also contain corticotrophin, but in view of the well known tendency of this hormone to become firmly bound to proteins, this finding is of doubtful significance. Only if it were shown that corticotrophin added to a suspension of granules did not become bound to them could the association of this hormone with the granules be regarded as indicative of its *in vivo* location.

The results of Brown and Hess (1957) are not in conflict with Herlant's findings, although they interpreted them as showing somatotrophin in the mitochondrial fraction. Having experimented with both sheep and beef pituitaries, I am of the opinion that Brown and Hess underestimated the rate of sedimentation of acidophil granules, and that there is no likelihood of sedimenting the mitochondria in this material and leaving the acidophil granules in the supernatant.

Combining the evidence obtained from assays of tissue and of separated granules, it can be concluded that cells of the acidophil cell class produce somatotrophin and prolactin, and that these hormones are stored in their granules.

#### F. ACIDOPHIL CELL TYPES

In some species an easy differentiation of the acidophil cells of the pars anterior into two specific types is obtained by staining methods. The differentiation depends on the tendency of the granules in one cell type to be stained orange with Orange G, whereas the other type is stained a red color with azocarmine in the azan method, or with acid fuchsin in Crossmon's (1937) method, or with erythrosin in the Cleveland-Wolfe method used by Wolfe, Cleveland and Campbell (1933).

It will be convenient for the purposes of discussion to adopt the term "carminophil" used by Friedgood and Dawson (1940) for red-stained cells, and the term "orangeophil" used by Lacour (1950) for orange-

stained cells. These terms are expressive of the relative affinity of the two types of granules in a species in which such a differentiation is obtained. The term "orangeophil cell" means the cell whose granules show the greater tendency to orange staining; the term "carminophil cell" means the cell whose granules show the greater tendency to be stained red, whether by azocarmine, acid fuchsin, or erythrosin. The equivalence of the three methods was demonstrated in the dog by Hartmann, Fain and Wolfe (1946), and by Goldberg and Chaikoff (1952a). I find that Crossmon's method gives in the human pituitary an equivalent differentiation to that obtained by Romeis (1940) with a modified azan method (Fig. 3.6). The results are most convincing when a differentiation is obtained by Crossmon's method, because in this method the differentiation appears spontaneously on staining the slide in an acidified mixture of orange G and acid fuchsin. The ease with which the differentiation is achieved varies in different species. In the sheep the Crossmon method gives two shades of red-orange or orange-red that are distinguished from each other only with difficulty, whereas in the dog the colors are pure orange and pure red. The azan method permits of modifications both in the solu-

tions and the sequence which allows it to be accommodated to the varying staining properties in different species. The azan method, therefore, allows differentiations to be obtained that are not possible by simpler methods. For this versatility a price must be paid in the form of a tendency to inconsistent and variable results.

An orangeophil-carminophil distinction has been reported in the hypophyses of the dog (Wolfe, Cleveland and Campbell, 1933; Hartmann, Fain and Wolfe, 1946); armadillo (Oldham, 1938); rabbit and cat (Dawson and Friedgood, 1937, 1938a; Dawson, 1939; Friedgood and Dawson, 1940); man (Romeis, 1940); bovine (Gilmore, Petersen and Rasmussen, 1941); opossum (Dawson, 1938); ferret (Dawson, 1946); monkey (Dawson, 1948); bat (Herlant, 1956a); and wallaby (Ortman and Griesbach, 1958). In vertebrates other than mammals two types of acidophils have been recognized in the hypophyses of birds (Rahn, 1939; Rahn and Painter, 1941; Payne, 1942, 1943); snakes (Hartmann, 1944; Cieslak, 1945); newts (Copeland, 1943); fishes (Scruggs, 1939); and frogs (Green, 1951).

It is not certain that the two types of cells observed in some of the above investigations were both acidophils. Mikami (1957) considers the cells stained orange by the azan

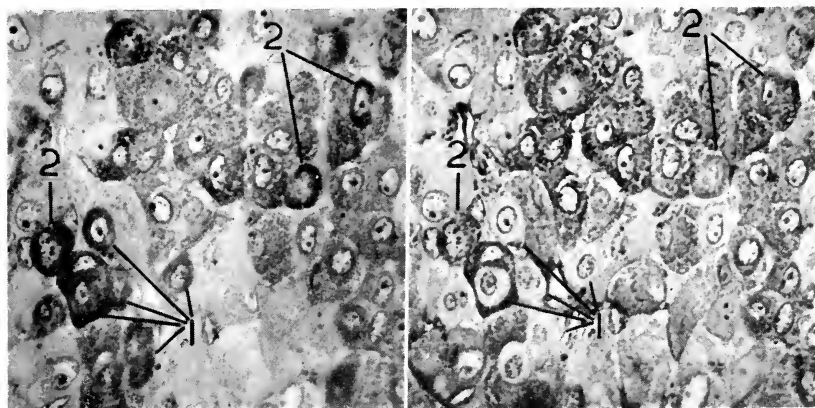

FIG. 3.6 (*left*). Section of the pars anterior of the dog showing two types of acidophil cell as seen after Crossmon staining. (1) Orangeophils; (2) carminophils. Crossmon,  $\times 820$ .

FIG. 3.7 (*right*). The same section as Fig. 3.6 decolorized and restained by PAS. The orangeophils (1) are pale, whereas the carminophils (2) are distinctly stained. Other cells which are more intensely colored by PAS than by Crossmon, are basophils. PAS,  $\times 810$ .

method in the rostral zone of the pars distalis of the fowl to be basophils because their granules are intensely stained by the PAS reaction. Of different significance are the definite but relatively weak colorations observed in the carminophil cells of the dog (Purves and Griesbach, 1957a), and frog (Ortman, 1956a). The amount of color formed must be considered in relation to the amount of protein present. In the fully granulated acidophil cell there is a large amount of protein. With close packing of the granules, as much as 50 per cent of the cytoplasmic space can be occupied by solid protein granules. The amount of specific protein in basophil cells is usually very much less. Any nonspecific staining of proteins, such as by a weak iodine solution, or by the methods used for staining paper electrophoresis strips, will show the high protein content in the fully granulated acidophil. Calculations based on the color produced by PAS in the mixed proteins of blood plasma (approximately 7 per cent solution of protein containing 1 per cent of sugar by weight) make it evident that quite a strong color would be produced in acidophil cells if there were but one reacting group per molecule of protein. It is only when the color is intense in relation to the amount of protein reacting that the presence of many reacting groups and, therefore, probably the presence of polysaccharide, may be inferred. The color produced in the granules of carminophil cells is not of this intensity.

In order to resolve the doubt concerning the significance of moderate PAS colorations in heavily granulated cells, Purves and Griesbach (1956) used a preliminary buffer extraction before fixation and found that the carminophil granules in the dog were insoluble, and were still stainable by PAS after extraction at pH 7.5, a treatment that dissolved all the basophil granules. They, therefore, defined basophil granules as granules containing *soluble* glycoproteins. This definition enables one to bypass the question "Is the PAS reaction in carminophil granules sufficiently strong to indicate the presence of glycoprotein?", the answer to which is a matter of opinion, and to substitute for it a practical solubility test which is easy to carry out and interpret.

When a sensitive PAS sequence is used, acidophil cells generally show a weak color which is easily masked by counterstaining (Fig. 3.7). The cytoplasm of chromophobes shows a similar weak coloration; against this background the acidophils may appear to be unstained. The granules of the carminophil cells of the sheep, dog, frog, wal-laby (Ortman and Griesbach, 1958), and cat (Herlant and Racadot, 1957), give reactions distinctly stronger than this. The observation of Pearce (1951) that the carminophil cells of the rabbit do not contain glycoprotein does not exclude the possibility of a weak reaction in this species, because he used the Hotchkiss (1948) modification of the PAS sequence, which suppresses weak reactions and is allegedly more specific for glycoproteins.

Herlant and Racadot inferred that the carminophil cell in the cat was a basophil, but because the color produced by the PAS reaction is weak compared to that in typical basophils, I would regard this as a case to be submitted to the solubility test before a definite decision is made.

#### G. SECRETORY FUNCTIONS OF ACIDOPHIL CELL TYPES

In view of the evidence presented earlier, which indicates that acidophil cells secrete somatotrophin and prolactin, it can be expected that in species in which two types of acidophil can be distinguished, one type will secrete somatotrophin, the other prolactin. The reactivities of the cell types in mammals, in which two types are distinguishable, show that this is indeed the case and the point is discussed at some length in the section on acidophil cells and somatotrophin secretion which follows.

In general one of the two specific cell types is reactive in relation to the reproductive cycle and shows marked fluctuations in activity, which can be correlated with the secretion of prolactin at times when its luteotrophic, mammatrophic, or lactogenic action is apparent. The second type is relatively stable in relation to the reproductive cycle, and is assumed to secrete somatotrophin. Evidence in support of this assumption is available in some species.

Mammals in which the carminophil cells

are active during pregnancy and lactation in the cat (Dawson, 1946; Herlant and Racadot, 1957), rabbit (Pearse, 1951), monkey (Dawson, 1948), and bat (Herlant, 1956a).

In the rabbit the discharge of luteinizing hormone which causes ovulation occurs within 1 hour after coitus. Pearse (1951) found at this time a discharge of granules from basophil cells which presumably were secreting luteinizing hormone. For the first 3 to 4 hours after coitus the carminophil cells were accumulating granules; thereafter there was a slow discharge of granulation during the next 10 hours. These changes in the carminophil cell are consistent with a luteotrophic function for the secretion of these cells.

The responses of the carminophil cell of the cat (Dawson, 1946) are similar to those of the rabbit. They are consistent with an accumulation of granules at estrus and for a time after mating, with a secretion with luteotrophic action immediately after ovulation, with a further accumulation of granules during the later stages of pregnancy when a luteotrophic action by the hypophysis is not necessary, and with a phase of strong secretory activity with a lactogenic action, beginning at parturition and continuing for the first 3 weeks of lactation. It should be noted here that Herlant and Racadot (1957), while confirming the luteotrophic action of carminophil cell secretion, consider that in the cat this cell secretes the luteinizing hormone. They relate lactogenesis to the secretion of a hormone, presumably prolactin, by chromophobe cells, which are rich in cytoplasmic ribonucleic acid. I am inclined to think, from the similarity in the responses of carminophil cells in cat and rabbit, that they serve the same function in both species, but admit the necessity for further investigation in the cat.

Because of its unusual breeding cycle, the bat (Herlant, 1956a) presents peculiar advantages for the correlation of specific cell types with specific secretion. In this species the carminophil cells show two phases of secretory activity during the breeding cycle. The first phase begins at the time of ovulation and terminates during the latter half of pregnancy; the second phase begins a little before parturition and continues throughout lactation. In animals which do not lactate,

these cells involute rapidly after parturition. The responses indicate secretion of prolactin with luteotrophic and lactogenic actions at appropriate times.

In two mammalian species the carminophil cell is the stable type, and the orangeophil the reactive type during the breeding cycle. These are: (1) Human hypophysis. The orangeophil cells are active during pregnancy and contain orangeophil granulation towards the end of pregnancy. These cells have been called pregnancy cells by Erdheim and Stumme (1909). Romeis (1940) calls the orangeophil cells seen in small numbers in the hypophyses of males and nonpregnant females "ε"-cells, and the numerous orangeophil cells seen in late pregnancy "γ"-cells. Any differences between the two are presumably due to different states of activity. The granules of both show the same staining reactions, and only one type of orangeophil cell is seen in any one hypophysis. (2) The rat (Lacour, 1950; Dawson, 1954a). Purves and Griesbach (1952) inferred the separate existence of somatotrophin and prolactin-secreting cells from the differential effects of estrogen and a deficiency of thyroxine on the acidophil cell population, but could not achieve a tinctorial differentiation. The orangeophil staining achieved by Lacour was not reproducible. Dawson's (1954a) modification of the azan stain has usually given an orangeophil reaction in the active-looking acidophils of the pregnant rat pituitary, and in the similar cells appearing after estrogen administration but the staining is sometimes unsuccessful. Obviously the staining affinities of the two types of granulation in the rat are very similar.

In all these species except the rat, the reactive acidophil type, whether it be the carminophil cell in the cat, rabbit, monkey or bat, or the orangeophil cell in the human hypophysis (Floderus, 1949), has a different distribution from that of the nonreactive type, and the marked increase in the number of visible cells at certain times is due to the appearance of granules in previously nongranulated, and, therefore, chromophobic cells. In the rat the orangeophil staining appears to be the result of a change in the nature of the granules in a proportion of the acidophils, which

in the normal nonpregnant animal are carminophil.

It appears, then, that in a number of mammals the secretion of somatotrophin and the secretion of prolactin are the functions of two distinctive acidophil types, not transformable into one another, and with variable staining reactions in different species. In most of the species studied thus far, the prolactin-secreting cell is the more carminophil type. In view of the variations in staining affinities which make the differentiation of two types by staining methods easy in some species and difficult in others, it is possible that in some species two types of acidophil occur whose granules stain alike, and the human hypophysis is presumably one in which the prolactin-secreting cell is the more orangeophil. The variability in the nature of the hormones in different species (the variability of somatotrophin is particularly well attested) makes this variability in the staining reactions of cells serving the same functions in different species credible.

Some recent observations indicate that more than two acidophil cell types may be present in some species. Herlant (personal communication) has found four distinct acidophil cell types in the pars anterior of the mole (*Talpa europaeus*), and Ortman and Griesbach (1958) have evidence for four acidophil cell types in the wallaby (*Wallabia rufogrisea*).

Purves and Sirett (1959) found prolactin concentrated in the rostral portion and somatotrophin concentrated in the caudal portion of the anterior lobe of the wallaby hypophysis. Somatotrophin, therefore, is secreted by orangeophil cells in the caudal zone of the pars anterior, and it is probable that the carminophil cells of the rostral zone are the source of the prolactin.

#### II. ACIDOPHIL CELLS IN RELATION TO SOMATOTROPHIN SECRETION

The association of the acidophil cells with the production of growth hormone was first deduced from the observations of acidophil cell adenomas in the hypophyses of patients showing the symptoms of acromegaly or gigantism, and, as Cushing and Davidoff stated in 1927, no one today can have any reasonable doubt that the sub-

stance which provokes the overgrowth is a product of the acidophil cells.

The absence of acidophil cells in the pars anterior of the dwarf mouse (Smith and MacDowell, 1930) is often cited as evidence for the origin of a growth-regulating hormone secreted by the acidophil cells. Smith and MacDowell's report indicated that there may be deficiencies in cell types other than the acidophils, but Ortman (1956b) finds that basophils, both  $\beta$ -cells and  $\delta$ -cells, are present and appear similar to those present in normal litter mates. It seems, therefore, that there is a specific deficiency in growth hormone secretion associated with a deficiency of acidophil cells in these animals. However, the dwarf mice also show evidence of deficient thyrotrophic, gonadotrophic, and adrenocorticotrophic secretion and growth may be stimulated in them by thyroxine administration (Nielson, 1952) as well as with growth hormone. Treatment with both hormones is necessary to produce the appearance of full-grown mice. The lack of acidophils in the dwarf mouse hypophysis cannot be due to degranulation of these cells by thyroxine deficiency, because thyroxine administration does not cause regranulation.

Hewer (1943) described a case of human dwarfism in which the hypophysis was markedly deficient in acidophil cells.

It should be noted that the cessation of growth in the rat after hypophysectomy is due to the loss of thyrotrophin and consequently of the thyroid secretion as well as the loss of somatotrophin. This view is necessitated by the observations of Geschwind and Li (1952) who showed that either thyroxine or somatotrophin produces growth in hypophysectomized rats. Changes in the hypophysis resulting from thyroxine deficiency accompany the arrest of growth which occurs in totally thyroxine-deficient rats. Zeckwer, Davison, Keller and Livingston (1935) pointed out that the disappearance of acidophil cells occurs in the rat hypophysis after thyroidectomy and related this to the cessation of growth in such animals, because in partial thyroxine deficiency resulting from incomplete ablation of the thyroid, the acidophil cells were retained and growth continued. The relation of the acidophil cell degranulation to thyroxine



supply was studied by Purves and Griesbach (1946) who showed that, although 2.5  $\mu\text{g.}$  of DL-thyroxine were required to prevent thyroidectomy changes in the basophils of the rat hypophysis, the acidophils were protected from degranulation by 0.5  $\mu\text{g.}$  per day and the effect of even smaller quantities in retaining some of the acidophil cells was observed. The rate of growth observed in these animals was related directly to the content of acidophil granules.

Degranulation of the acidophil cells occurs in rats treated with potent goitrogenic agents. As judged by the acidophil cell response, thiourea is much less effective than thiouracil in suppressing thyroid secretion because the administration of 0.25 per cent of thiourea in the drinking water does not cause the loss of acidophil cells.

Using the regranulation of the acidophil cells as a sensitive indicator of small amounts of thyroxine, Purves and Griesbach (1946) demonstrated that the administration of iodide in relatively high dosage (1 mg. per day) produced in thyroidectomized rats an extrathyroidal synthesis of material with thyroxine-like activity in amounts which were of physiologic significance. The partial regranulation of the acidophils on high iodide intakes in totally thyroidectomized animals is associated with continued growth at a subnormal rate. They concluded that from injections of 1.3 mg. of potassium iodide per day, approximately 0.12  $\mu\text{g.}$  of L-thyroxine might be produced. Hum, Goldberg and Chaikoff (1951) showed that injections of iodide (1 mg. per day or more) caused regranulation of acidophil cells in rats whose thyroid tissue had been destroyed by administration of radioactive iodine and considered that the effect was due to extrathyroidal synthesis of thyroxine.

Marine, Rosen and Spark, (1935) reported almost total loss of acidophils from the hypophyses of thyroidectomized rabbits, but overlooking changes in the basophil cells, they related the acidophil cell changes to the production of thyrotrophic hormone.

In the thyroxine-deficient dog, changes in the acidophil class of cell are apparently limited to the  $\alpha$ -cell. Goldberg and Chaikoff (1952b) observed in dogs with com-

plete thyroid destruction produced by radioactive iodine, a complete degranulation of the  $\alpha$ - (orangeophil) cells whereas the  $\epsilon$ - (carminophil) cells were well preserved and full of granules. The animals were adult and the effect on growth was not observed. The selective degranulation of the  $\alpha$ -cells is, however, consistent with the view that these cells are concerned with somatotrophin secretion.

## VIII. The Basophil Cell Class

### A. BASOPHIL GRANULES

In the light of modern knowledge basophil granules are defined as secretory granules containing soluble glycoproteins. The McManus (1946) PAS reaction serves as a group reaction for the identification of all granules of the basophil class, as it imparts to them an intense red or magenta color indicative of a high content of protein-bound carbohydrate. Glycogen and certain lipid inclusions are two other intracellular substances which can be colored intensely by the PAS reaction. In paraffin sections pretreated with diastase these substances will be absent. Insoluble substances of an unknown nature which give a color with the PAS reaction occur in some acidophil cells, and should be sought for in material submitted to extraction before fixation.

Suitable extraction methods are: (1) Freeze and thaw the tissue on the stage of a freezing microtome three times before fixation. Basophil granules will dissolve in the mixture of intracellular and extracellular fluids. (2) Place small pieces of tissue in cold alcohol or acetone for 30 minutes, then in buffer for 1 hour before fixation. This allows some control of the pH at least in the peripheral portions of the tissue. (3) Perfuse the animal by way of the aorta with buffer which is saturated with ether at 37°C., or to which desoxycholate has been added as a cytolyzing agent. This method allows the assay of the extracted tissue for content of unextractable hormones. In the other methods the granule contents, although in solution, still remain to a large extent inside the tissue.

It should be pointed out here that mechanical damage resulting from the handling of the delicate tissues of the hypophyses of

smaller animals causes a loss of the granules from basophil cells. Such hypophyses are best fixed *in situ*.

Basophil granules show a high capacity, but only a weak binding power, for basic dyes (Peterson and Weiss, 1955). This basophilia does not serve for the characterization of basophil granules because of the prevalence of cytoplasmic basophilia and the staining of acidophil granules by basic dyes.

There has in the past been some confusion between the basophilia of basophil granules and that of ribonucleic acid. Dempsey and Wislocki (1945) pointed out that the staining of basophils with aniline blue was not concerned with cytoplasmic ribonucleic acid, and suggested that the aniline blue stained an acidophil substance which represented the true secretory granules of the cells. The nature of the specific granules in basophil cells was clarified by the researches of Herlant (1942), who observed a violet metachromatic staining of the basophil granules in the human pituitary by neutral solutions of toluidine blue. This metachromasia is observed only in undehydrated sections and demonstrates a specific type of basophilia quite distinct from that due to cytoplasmic ribonucleic acid. This type of basophilia, which is common to many sites containing polysaccharide material, was considered by Herlant to indicate that the specific granules of the basophil cells were composed of glycoprotein. After a short treatment with alcohol to cytolyze the cells, the glycoprotein material was found to be extractable by water, and the resultant extract was rich in FSH. Herlant demonstrated the glycoprotein nature of the basophil granules by the Bauer method for polysaccharide, and the observations were subsequently confirmed by the more satisfactory McManus (1946) method for glycoprotein (Herlant, 1949). Other observations confirming the glycoprotein nature of basophil granules have been reported by Catchpole (1947, 1949), Pearse (1948), and Purves and Griesbach (1951a).

The Herlant metachromasia is observed in the basophil granules and indeed in all PAS stainable structures in rat, dog, and human hypophyses. This metachromasia does not serve to characterize basophil gran-

ules, inasmuch as the carminophil cells of the dog and of the wallaby are also metachromatically stained by toluidine blue.

Basophil granules vary considerably in size in different species. In the rat they are seen in electron micrographs as spherical bodies of a maximal size of 150  $\mu$ . The individual granules are not seen by the light microscope, and the flocculent "granules" seen in stained sections are the result of the uneven distribution of the granules and their aggregation during fixation and dehydration. In the human hypophysis the basophil granules are much larger, and are singly visible in lightly granulated cells in stained sections. They vary greatly in size and the largest among them are as large as, or larger than, acidophil granules.

In fresh tissue the basophil granules do not show the high refractility of the solid acidophil granules, and are therefore presumed to be vesicular, consisting of a membrane enclosing a solution of glycoprotein.

The staining procedures most generally used in the study of the cytology of the adenohypophysis are various trichrome procedures using mixtures of acid dyes. As has been said before, by these methods basophil granules may be stained orange, red, purple, or blue. By such methods it is, of course, not in general possible to distinguish acidophil granules from basophil granules. This was not realized until recently because of a premature assumption that only two types of chromophil cells are present in the pars anterior of mammals, and because of a widespread erroneous belief that all blue dyes are basic dyes. In the literature, the term "basophilic" is constantly applied to structures stained blue by aniline blue in variations of the trichrome staining procedures and is, therefore, used as a synonym for blue rather than as an indication of staining affinity.

It may be stated here, as regards the multiplicity of basophil cell types included in the basophil cell class, that the pars intermedia cells are basophils, and that there are in addition three specific types of basophil cells distinguishable in the pars anterior of certain favorable mammalian species. The immediately succeeding sections are concerned with the basophil granules and the basophil cell types of the pars anterior.

## B. HORMONE CONTENT OF BASOPHIL CELLS

Evidence of the hormonal content of basophil cells can be obtained by the assay of portions of tissue rich in basophil cells and comparison with the results obtained from adjacent portions rich in acidophil cells. Investigations of this type have been made by Smith and Smith (1923b), Voitkevitch (1937a, b), Herlant (1943), Smelser (1944), and Giroud and Martinet (1948). These investigators agree that tissue rich in basophil cells has a high content of thyrotrophin and gonadotrophin. It seems that the gonadotrophic effects include both follicle-stimulating and luteinizing actions. Corticotrophin in both pig and bovine anterior lobes is also somewhat more concentrated in the basophil zone. Because of the prevalence of chromophobes as well as basophils in the basophil zones, it cannot be inferred that all these hormones are in the basophil cells. Moreover, Smelser has shown that the ratio of the potencies of the two zones is different for thyrotrophin, corticotrophin, and gonadotrophin, so that these hormones seem to be stored in different cells.

Inasmuch as three distinctive types of basophil cell can be seen in the pars anterior of some other species, it is likely that a similar diversity occurs in the bovine hypophysis. This species is, however, not favorable for the discernment of specific basophil cell types.

## C. HORMONE CONTENT OF BASOPHIL GRANULES

The basophil granules are sensitive structures, and lose their glycoprotein content when the cells in which they are contained are damaged, as by freezing or mechanical distortion. It appears that this is the result of the instability of the enclosing membrane to solutions of low osmolar content.

Thyrotrophin, FSH, and LH are, like the glycoproteins of basophil granules, soluble in water at neutral pH, and are completely extractable from anterior lobes after acetone drying or mechanical disintegration. These hormones seem to be located in membrane-enclosed structures in living cells, because they can be centrifuged down from suspensions of anterior lobe tissue disintegrated in 0.88 M sucrose. McShan and

Meyer (1952), and McShan, Rozich and Meyer (1953), using the anterior lobes of castrate rats, were able to recover as much as 75 per cent of the gonadotrophin in a small granule fraction sedimented by centrifuging at  $20,400 \times g$  for 1 hour. There was evidence that grinding increased the amount of hormone in solution, presumably by disruption of granules. The hormone was extracted from the granules by isotonic saline, and from this solution could no longer be sedimented. This behavior is accounted for by the enclosure of the hormone in a membrane with properties similar to that of the mitochondrial membrane and, therefore, stabilized by high sucrose concentrations.

Herlant (1952a) worked with the anterior lobes of sheep, pig, and beef hypophyses, and obtained a small granule similar to that obtained by McShan and his associates which contained gonadotrophic activity. He found that these small granules gave an intense coloration with the PAS reaction, and thus demonstrated that they were basophil granules. It does not seem that the thyrotrophin content of the small granule fraction has been tested except by Brown and Hess (1957). Their results are not easily interpreted because they sometimes used frozen instead of fresh beef anterior lobes and their fractions are wrongly identified, but it does seem that thyrotrophin can be centrifuged down from material dispersed in sucrose solution (0.25 M in their experiments).

Although these observations are not by themselves conclusive, when considered in conjunction with the cytologic observations presented in the succeeding section, they provide confirmatory evidence for the view that thyrotrophin, FSH, and LH are made by basophil cells and are contained within their characteristic granulation. The behavior of corticotrophin in tissue dispersed in solution needs further investigation.

## D. DOES THE PERIODIC ACID-SCHIFF REACTION DEMONSTRATE THE HORMONE CONTENT OF BASOPHIL CELLS?

The fact that in the rat pars anterior the amount of PAS reacting material in thyrotrophs, FSH cells, and LH cells, parallel the content of thyrotrophin, FSH, and LH,

respectively, raises the question as to whether or not the hormones themselves are responsible for the staining reactions. The parallelism between depth of staining and hormone content does not contribute to the solution of this problem, because this parallelism is a consequence of the fact that the hormone is stored in the specific granules and the number of granules present determines the depth of staining. This question, therefore, resolves itself into two parts. First, are the hormones glycoproteins, and second, are the hormones major constituents of the granule contents?

The reported sugar contents of the preparations of thyrotrophin, FSH, and LH produced by the fractionation of extracts from the anterior lobes of domestic animals do not establish the glycoprotein nature of the hormones, because it has never been shown that similar glycoprotein-containing fractions do not result from the fractionation of extracts of tissue which are free from these hormones. Taking advantage of the ease with which rat hypophyses can be obtained free from these particular hormones by pretreatment of the animal with thyroxine and estrogen, I have compared the extracts from hormone-free anterior lobes with those from normal anterior lobes. Similar amounts of protein with similar sugar contents were extracted from both types of gland. Fractionations by salt or alcohol which resulted in potent preparations of thyrotrophin, FSH, and LH, when applied to the extracts of the normal gland, gave a similar partition of the glycoproteins extracted from the hormone-free gland. It is clear that the preparations of the reputedly glycoprotein hormones obtained by fractionation of glandular extracts with varying concentrations of salts or alcohol are composed mainly of inert materials resulting from the fractionation of a mixture of plasma proteins and soluble cytoplasmic constituents.

In extracts from castrate rat anterior lobes in which the gonadotrophins are present at many times the normal level, the FSH fraction contains a small but definitely increased amount of PAS reacting material compared with the corresponding fraction from an equal weight of hormone-free anterior lobe. There is, therefore, in the baso-

phil granules a glycoprotein which accompanies the FSH during fractionation of the extract, and this glycoprotein is present in amounts which would contribute to the staining reactions of the granules. The potency of this material is close to that of the highly purified FSH preparations reported by Stechman, Kelly, Segaloff and Weber (1956).

Persons observing pars anterior cells under the microscope often form impressions which exaggerate the amount of specific granulation present in the pars anterior. They often also have exaggerated ideas about the potency of the separated hormones. Taking account of the small percentage of granulated thyrotrophs in the rat pars anterior and the small fraction of the cytoplasmic content of these cells which is in the form of granules, there must be only about 1  $\mu\text{g}$ . of specific thyrotroph granulation per mg. dry weight of anterior lobe. Yet the anterior lobe has a potency of 0.2 I.U. thyrotrophin per mg. dry tissue, equivalent to 10  $\mu\text{g}$ . of the potent preparation of thyrotrophin obtained by Condliffe and Bates (reported by Sober and Peterson, 1958).

It seems reasonable to assume that basophil granules, like other specific secretory granules, contain a mixture of substances, and it appears likely that, at least in the rat pars anterior, the glycoprotein hormones form a considerable proportion of the granule content and contribute significantly to its staining reactions.

#### E. DIFFERENTIAL STAINING OF BASOPHIL CELLS BY RESORCIN-FUCHSIN, KRESOFUCHSIN, ALDEHYDE-FUCHSIN, AND ALCIAN BLUE: $\beta$ -CELLS AND $\delta$ -CELLS

The three basophil cell types in the pars anterior of some mammals can be distinguished from each other by diagnostic features which are independent of any specific differential staining of the granules, but even in these species a differential staining of the specific granulation is an important aid in the study of specific types. In some species the granules of different cell types react differently to acid dyes and appear in different colors after trichrome staining methods. The recognition of the presence of a multiplicity of basophil types was

delayed not so much by the difficulty of distinguishing between them as by the difficulty of recognizing the basophil nature of the different types in the species in which the different types were highly distinctive. It is for this reason that the first clear recognition of two types of basophil cells came from the discovery of Romeis (1940) that kresofuchsin applied to sections of human pars distalis gave a differential staining of the granules of cell types that by the azan procedure were stained alike. There seem to be four types of basophil cells in the human pars distalis. Two of them which Romeis did not consider sufficiently distinctive to warrant separation were designated by him as " $\beta$ -cells." The other two types he designated as " $\gamma$ -cells" and " $\delta$ -cells." Kresofuchsin stained the granules of both types of  $\beta$ -cells and left the granules of  $\gamma$ -cells and  $\delta$ -cells unstained. The  $\beta$ - and the  $\delta$ -cells after azan staining were so much alike that a clear differentiation between them could be obtained only by the use of kresofuchsin, but the  $\gamma$ -cells were so distinctive that the use of kresofuchsin to distinguish them from  $\beta$ -cells was not necessary. In this way kresofuchsin acquired a reputation for distinguishing  $\beta$ -cells from  $\delta$ -cells rather than for distinguishing  $\beta$ -cells from  $\gamma$ -cells and  $\delta$ -cells. The premature assumption that only two types of basophil cells would be present in the pars distalis of man and the pars anterior of other mammals led to the widespread use of the terms " $\beta$ " and " $\delta$ " to designate cell types or cell groups in species other than man, and thus set the stage for an episode of nomenclatural confusion, the results of which have been exacerbated by a naive assumption that cell types designated by the same Greek letter by different authors in different species ought to have the same functions.

The history of the use of elastic tissue stains—kresofuchsin, resorcin-fuchsin, and aldehyde-fuchsin—is interesting and shows the difficulties that are experienced with the use of these materials. Erdheim and Stumme (1909) introduced the use of resorcin-fuchsin as an elective stain for the granules of basophil cells in the human hypophysis, and it appears among the staining reactions listed by Bailey and Davidoff

(1925) as characteristic of basophil cells. The term " $\beta$ " was proposed by these authors to replace the term "basophil" which they thought was too specific in meaning to characterize a type of cell which could be stained specifically in several ways, some of which did not appear to involve basophilia.

Berblinger and Burgdorf (1935), in a study of connective tissue in the human hypophysis, used the commercially available kresofuchsin as a stain for elastic tissue, and counterstained with orange G—phosphomolybdic acid and aniline blue. They noticed in the pars distalis that, although kresofuchsin stained the granules of some of the basophil cells, there were other cells which did not differ in any visible respect except that their granules were not stained by kresofuchsin and were stained only by the aniline blue. Thornton (personal communication) and I too have observed the same phenomenon with paraffin sections of formalin-fixed human hypophyses stained with aldehyde-fuchsin. According to the age of the aldehyde-fuchsin solution and the duration of staining, the granules of a varying proportion of the basophils are stained with aldehyde-fuchsin, whereas others remain unstained in an erratic and nonreproducible fashion that cannot possibly represent a distinction between different functional cell types. Rodriguez (1937) used Berblinger and Burgdorf's staining combination in a study of the cells of the anterior lobes of the hypophyses of a number of mammalian species. He found kresofuchsin-stainable granulated cells in bovine, horse, sheep, dog, monkey, and rabbit hypophyses. He did not find such cells in the guinea pig or rat, although there were in these species cells with a diffuse staining.

Using resorcin-fuchsin for the staining of basophil cells, von S6os (1934) apparently obtained results similar to those produced by kresofuchsin. He found cells with resorcin-fuchsin stainable granules in nine mammalian species but not in birds. In most species the number of basophil cells revealed by resorcin-fuchsin was similar to the number shown by Mallory staining of adjacent sections.

At the time of the above-mentioned investigations, Romeis was using a combina-

tion of kresofuchsin and Heidenhain's azan which, although differing in details from the method of Berblinger and Burgdorf, should have given, as far as the basophils were concerned, equivalent results. His results are published in his magnificent monograph (Romeis, 1940) on the hypophysis. Unlike the results of Berblinger and Burgdorf, kresofuchsin in Romeis's hands gave a clear-cut discrimination between two distinctive groups of cells, those whose granules stained with kresofuchsin and those whose granules stained not with kresofuchsin but only with the aniline blue of the azan stain. During his investigation Romeis found that the kresofuchsin supplied by the manufacturers differed from that he had obtained earlier in that, while still staining elastic tissue, it was no longer useful for staining the hypophysis. He found that resorein-fuchsin he made himself could be substituted for kresofuchsin with results which were equal in every respect.

Romeis examined the hypophyses of a number of mammalian species other than man with results that differed from those of Rodriguez and von Söos in some respects. He found cells with granules stainable by kresofuchsin or resorein-fuchsin in some species in which these authors had not been able to demonstrate them. As has been stated earlier, Romeis called the cells whose granules stained with kresofuchsin  $\beta$ -cells, and those whose granules did not stain with kresofuchsin, but were stained with aniline blue,  $\delta$ -cells. He found both  $\beta$ - and  $\delta$ -cells in the bovine hypophysis and in the hypophyses of the dog, horse, cat, and rat. He found  $\beta$ -cells alone in the bat and guinea pig; in the latter they were very scanty. He also noted that kresofuchsin stained strongly the pars intermedia cells in the guinea pig, mouse, and pig.

The results that Romeis obtained with resorein-fuchsin have been duplicated by Ezrin, Swanson, Humphrey, Dawson and Wilson (1958). Despite many attempts, other investigators have not been able to repeat these results using Romeis's method. There is, however, no doubt about the correctness of his observations.

Gomori (1950) introduced aldehyde-fuchsin as an elastic tissue stain, and Halmi

(1950, 1951a) used it to differentiate between  $\beta$ - and  $\delta$ -cells in the rat and mouse. It has since been used successfully by a number of authors and on a number of species. The question whether aldehyde-fuchsin gives results equivalent to those once given by kresofuchsin is one which is not easily answered. The results are variable, depending on the fixative and on the treatment of the slide before staining, so that the term "stainable by aldehyde-fuchsin" cannot be given any precise meaning. Moreover, there are in the pars anterior of many, if not all mammals, three types of basophil cells, and according to conditions, the aldehyde-fuchsin may stain the granules of one, two or all three types, or fail to stain any of them. I think, however, that it may be assumed, that with any particular fixative and prior treatment of the slide, the elements most readily stained by kresofuchsin or resorein-fuchsin would also be most readily stained by aldehyde-fuchsin.

Aldehyde-fuchsin suffers from the defect of variability in staining power from batch to batch, and it often happens, as Romeis found with kresofuchsin, that a batch of this stain will stain elastic fibers but fail to stain basophil granules. Gabe (1953) described the preparation of an aldehyde-fuchsin which can be kept as a dry powder. To obtain results equivalent to those given by Gomori's preparation it is necessary to dissolve this powder in a concentration of 0.5 per cent in 70 per cent alcohol acidified with hydrochloric acid. Gabe's own procedure does not give the same results.

Recently Herlant and Racadot (1957) have indicated that Alcian blue (Steedman, 1950) at pH 1 stains the basophil granules in the toad and cat hypophysis that are stained by aldehyde-fuchsin. I find that a 3 per cent solution of Alcian blue in 70 per cent alcohol acidified with hydrochloric acid stains rat and human hypophyses with results equivalent to those obtained with aldehyde-fuchsin except that elastic fibers are not stained. If this procedure proves equally useful in other species it may supplant aldehyde-fuchsin and thus eliminate the uncertainty attending the use of this at present indispensable stain.

## F. THE NOMENCLATURE OF BASOPHIL CELLS

One difficulty in the use of the term " $\beta$ " for a basophil cell type whose granules stain with aldehyde-fuchsin and " $\delta$ " for a basophil cell type whose granules do not stain with aldehyde-fuchsin is the presumption that only two types of basophil cells are present. In addition there is the possibility that with a different staining technique the staining reactions may be reversed, so that one man's  $\beta$ -cells could be another man's  $\delta$ -cells. When three easily distinguished cell types are present, it is necessary to show that the granules of only one type are stainable by aldehyde-fuchsin before the term  $\beta$  may be allocated. The naming of the remaining two types will be arbitrary whether one is called  $\delta$  or not. The major objection to the use of the terms  $\beta$  and  $\delta$  according to rules based on staining procedures is the lack of agreement as to which rule and which staining procedure should be used. Herlant (1956a) suggested that the terms  $\beta$  and  $\delta$  should be transposed in species other than man so that cells whose granules are stained by aldehyde-fuchsin would be called  $\delta$ -cells, and the cells whose granules are unstained would be called  $\beta$ -cells. There are in addition a number of usages of the terms  $\beta$  and  $\delta$  to denote cells distinguished by staining reactions other than aldehyde-fuchsin in its several variants. It seems therefore advisable to avoid altogether the application of these terms according to rule until there is agreement as to which rule is to be followed. The usages of Romeis in man, Halmi in the rat and mouse, and Goldberg and Chaikoff in the dog can best be regarded as arbitrary.

In the present account cells whose granules are stained by aldehyde-fuchsin after any specified staining procedure will be stated to be AF-positive and called AF cells after such procedure. Cells whose granules are not stained by aldehyde-fuchsin after such a procedure will be stated to be AF-negative and called non-AF cells. It is emphasized that cells which are AF-positive after one procedure may be AF-negative after a different procedure.

The varying degrees of acidophilia of basophil granules allow in some species a distinction between "purple" basophils and

"blue" basophils (Purves and Griesbach, 1957b). The granules of purple basophils retain more or less of the red component of azan or Crossman or other trichrome staining methods and appear in purplish shades after procedures that result in a blue coloration of the granules of blue basophils. Purple basophils can be distinguished from blue basophils by counterstaining PAS stained sections with phosphotungstic acid-orange G (Herlant, 1953). The purple basophils, being relatively acidophilic, retain the orange G and become brick red, whereas the blue basophils remain magenta.

In sections stained by aldehyde-fuchsin and counterstained by a trichrome method we may distinguish purple AF cells, blue AF cells, purple non-AF cells and blue non-AF cells. Inasmuch as in many species there are in the pars anterior two basophil types which can be distinguished from each other by certain diagnostic features, although their granules stain alike, it is necessary to introduce additional terms to enable each cell type to be given a distinctive name. Such terms can be derived from the distribution of the cells in the pars anterior—"peripheral" or "central," "rostral" or "caudal"—or from some other diagnostic feature—"pale" for lightly granulated cells, etc. Such terms have no precise significance; they are used merely to generate a sufficient number of terms to enable each distinguishable cell type to receive a distinctive name. Thus, after fixation in formol-sublimite there are in the rat pars anterior blue AF cells ( $\beta$ -cells of Halmi, functionally thyrotrophs), and peripheral and central blue non-AF cells (functionally FSH cells and LH cells, respectively). The advantage of these terms is that they are, or should be, free from any implication that cells similarly designated in different species must have the same function.

## G. SPECIFIC BASOPHIL CELL TYPES

It is now established that in the pars anterior of certain mammals (the rat, Purves and Griesbach, 1951a, 1954; monkey, Dawson, 1954b; bat, Herlant, 1956a; and dog, Purves and Griesbach, 1957a) three types of basophils can be distinguished. In the rat and bat, species which are favorable to

the identification of cell types, the three basophil cell types have been identified as thyrotrophs, FSH cells, and LH cells. It will be noted that it is possible to distinguish cell types by specific staining reactions or by other diagnostic features without identifying them. By "identification" is meant here the allocation of specific function or functions to a distinguishable cell type.

It is not yet certain that all vertebrates have separate FSH and LH or that the physiologic requirements of all species would require the two hormones, if present, to be secreted separately and by different cells. In some species there may be only one type of basophil cell with gonadotrophic functions. It is likely, too, that in some species the duality of the gonadotrophic basophils is concealed by the fact that the staining reactions of the two types may be so alike that a distinction by tinctorial methods cannot be easily or consistently obtained. The term "gonadotroph" can be used as an inclusive term to denote the two types of cells secreting gonadotrophins and is also applicable in cases where a distinction of two such cell types has not been made.

Thyrotrophs and gonadotrophs have been identified in the guinea pig (D'Angelo, 1955), *Xenopus* (Cordier, 1953; Saxén, Saxén, Toivonen and Salimäki, 1957), two species of fish, *Phoxinus phoxinus* (Barrington and Matty, 1955) and *Caccobarbus gersstä* (Olivereau and Herlant, 1954), and in the pars distalis of the fowl (Payne, 1944, 1949; Brown and Knigge, 1958; Mikami, 1957). From observations recorded by Her-

lant (1954a) it seems that a differentiation of two kinds of basophil cells presumably thyrotrophs and gonadotrophs is generally observable in amphibians and bony fishes.

#### H. THE THREE FUNCTIONAL TYPES OF BASOPHIL CELL IN THE RAT HYPOPHYSIS

The identification of three functional types of basophil cells was first achieved in the rat by means which did not depend on specific staining reactions, the shape of the cells, their distribution and other minor features (Fig. 3.8). The pars anterior of the rat hypophysis has certain advantages which helped these identifications. Its hormone content and secretory function have been extensively investigated. It contains an adequate number of well granulated basophils. Its small size allows its cell population to be evaluated under the microscope without an inordinate expenditure of time and the use of tedious cell enumeration techniques.

Another favorable quality shown by the rat hypophysis is its reactivity. The hormone content can be varied over a wide range by experimental procedures, and variations in secretion rate are accompanied by striking changes in the size and granule content of basophil cells. Especially conspicuous are the hyalinized cells derived from basophil cells. Under conditions of rapid secretion there is an accumulation of a structureless protein solution called hyaline substance in certain small cytoplasmic vesicles. By distension and coalescence of these vesicles one or more large hyaline-filled spaces result.

Evidence suggesting that the basophil cell class might consist of two distinct functional subdivisions, one concerned with thyrotrophic activity and one with gonadotrophic, was obtained from the study of the changes occurring after thyroidectomy and castration. In both these conditions an increase in the number and activity of cells of the basophil class are observed and the initial cellular hypertrophy is followed by hyalinization of a proportion of the basophills. The hyalinized cells appearing after thyroidectomy (Figs. 3.9 and 3.10) are called thyroidectomy cells, those appearing after castration (Figs. 3.11 and 3.12) castration or signet ring cells. In the rat there are a

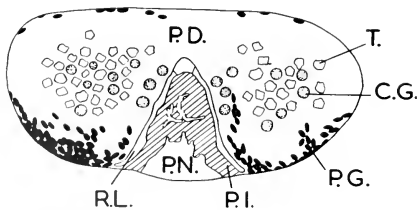

FIG. 3.8. Diagram of a horizontal section through the rat hypophysis showing the distribution of three types of basophil cell. P.D., pars distalis; P.I., pars intermedia; P.N., pars nervosa; R.L., hypophysial cleft or residual lumen; P.G., follicle-stimulating hormone cells (peripheral gonadotrophs); C.G., luteinizing hormone cells (central gonadotrophs); T., thyrotrophs.



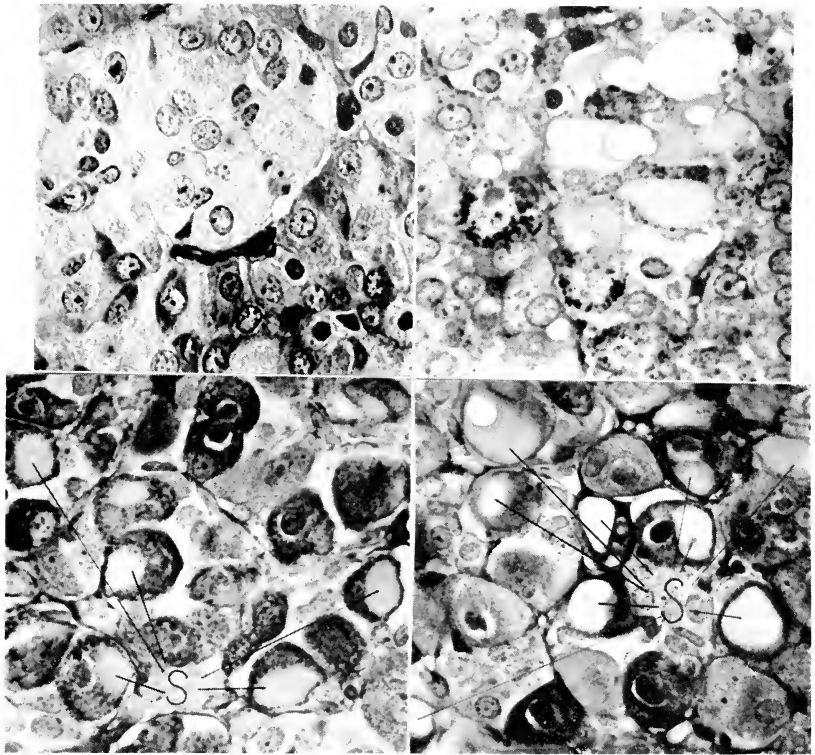

FIG. 3.9 (*upper left*). Section of the rat pars anterior showing the early response of the thyrotrophs to thyroidectomy (6 days after thyroidectomy). The cluster of large pale cells is formed by thyrotrophs which have degenerated but have not yet begun to hyalinize. PAS,  $\times 540$ .

FIG. 3.10 (*upper right*). Thyroidectomy cells in the rat pars anterior 66 days after thyroidectomy. Extensive accumulations of hyaline substance distort the cells. Normal specific granulation is absent. The coarse, intensely stained granules (*T* granules) are characteristic of prolonged thyroxine deficiency states. PAS,  $\times 780$ .

FIG. 3.11 (*lower left*). Section of the rat pars anterior showing changes in follicle-stimulating hormone cells 16 weeks after castration. The cells are numerous and large and a high proportion have accumulated hyaline material to form "signet-ring" cells. There is an increase in the content of granules which form coarse, darkly stained clumps. PAS,  $\times 580$ .

FIG. 3.12 (*lower right*). Section of the rat pars anterior showing changes in luteinizing hormone cells 16 weeks after castration. A proportion of the cells have accumulated hyaline material and formed "signed-ring" cells. Both hyalinized and nonhyalinized cells show varying intensities of staining indicating considerable variation in granule content in different cells. There is often a higher content of granulation within the Golgi body than in the peripheral cytoplasm. The characteristic difference between the appearances of the granulation in follicle-stimulating hormone and luteinizing hormone cells is retained after castration. PAS,  $\times 580$ .

large number of consistent differences between thyroidectomy and castration cells. Morphologic differences were observed by Hohlweg and Junkmann (1933), Zeckwer,

Davison, Keller and Livingood (1935), Zeckwer (1936, 1937, 1938a, b), and by Guyer and Claus (1935, 1937). A full account of the thyroidectomy and castration

TABLE 3.1  
*Differences between Castration and Thyroidectomy Cells in the Rat*

Castration Cells	Thyroidectomy Cells	Reference
Vesiculation gives rise to "signet-ring" cells	Vesiculation less regular	Schleidt (1914)
Vesicles are large, smooth, and well defined	Secretory accumulation less regular	Zeckwer <i>et al.</i> (1935)
Early stages do not resemble the early stages of thyroidectomy cells	Early stages full of fine foamy vesicles coalescing to form larger ones at 14th to 18th day	Zeckwer <i>et al.</i> (1935)
Not vesiculated at 5 weeks	Large amounts of hyaline material at 5 weeks	Zeckwer (1938a, b).
Uniformly granulated	Poorly granulated	Zeckwer (1938a, b).
Suppressed by estrogen	Not affected by estrogen	Zeckwer (1938a, b).
Generally a large single vesicle	Usually multiple vesicles	Guyer and Claus (1935, 1937)
Cells usually scattered	Cells commonly grouped	Guyer and Claus (1935, 1937)
Nuclei not vesiculated	Nuclei commonly vesiculated	Guyer and Claus (1935, 1937)
Golgi body conspicuous and regular	Golgi body diffuse	Guyer and Claus (1935, 1937)
Cytoplasm forms a definite band around the vesicle	Partitions between multiple vesicles are very fine and no band of cytoplasm at the periphery	Reese, Koneff and Wainman (1943)
Final size not great	Final size very great	Reese, Koneff and Wainman (1943)
Shape compact, oval, or round	Shape irregular, polyhedral	Reese, Koneff and Wainman (1943)
Only a proportion of the cells hyalinized	Practically all hyalinized	Reese, Koneff and Wainman (1943)
Nuclei and nucleoli not enlarged	Nuclei and nucleoli enlarged and vesicular	Reese, Koneff and Wainman (1943)
Mitochondria smaller	Mitochondria very large	Reese, Koneff and Wainman (1943)

cells was given by Reese, Koneff and Wainman (1943). The recorded differences between the two types of cells in the rat are summarized in Table 3.1.

Castration basophils, at first only weakly staining, become more strongly staining in the period from 2 weeks up to 4 months from operation. In long term experiments one of the striking differences between castration cells and thyroidectomy cells is the strong staining by aniline blue of the cytoplasmic granules of the castration cells whereas the thyroidectomy cells take so little stain that they have been considered by many observers to be chromophobes.

Zeckwer, Davison, Keller and Livingood (1935) were the first to trace the differences between these types of cells and to infer from them that these cells were the results of similar changes occurring in two distinct kinds of basophil cell. Guyer and Claus (1935; 1937), while observing differences in

the cells, considered they were explicable as being different processes occurring in the same cell type. Severinghaus (1939) did not consider the changes produced by thyroidectomy different in any fundamental way from those produced by castration. He was no doubt misled by the fact that a certain number of "signet-ring" cells are always present (Wolfe, 1941, 1943) and are therefore found in small numbers among the thyroidectomy cells in thyroidectomized animals.

The next important clue was provided by Reese, Koneff and Wainman (1943) who observed that two classes of basophil cells are normally present in rat hypophyses, one oval or round in section (Figs. 3.13 and 3.14), the other polygonal and angular (Fig. 3.15). They noted that in the early response to thyroidectomy there is an increase in the number of cells which are irregular or polyhedral, whereas after castration the in-

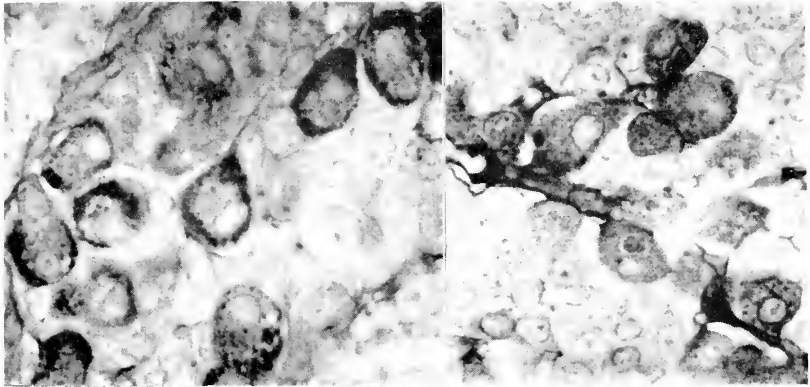

FIG. 3.13 (*upper right*). Section of the rat pars anterior showing follicle-stimulating hormone cells stained by periodic acid-Schiff (PAS). The cells are ovoid in shape and contain clumps of densely stained granules. PAS,  $\times 720$ .

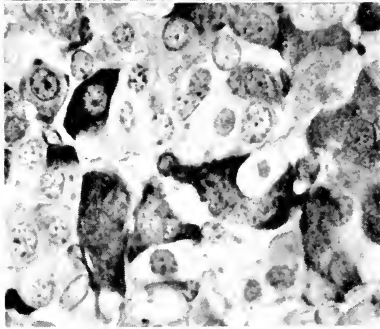

FIG. 3.14 (*lower left*). Section of the rat pars anterior showing luteinizing hormone cells stained by periodic acid-Schiff (PAS). The cells have rounded contours and the basophil granules are more uniformly dispersed throughout the cytoplasm than in the other two basophil types. One cell near the center of the field shows a prominent negative image of the Golgi body. The cytoplasm enclosed by the Golgi body has a higher granule content than the peripheral cytoplasm. PAS,  $\times 720$ .

FIG. 3.15 (*upper left*). Section of the rat pars anterior showing thyrotrophs stained by aldehyde-fuchsin (AF). The cells have angular contours and there is a tendency for the granules to be concentrated at the periphery. AF,  $\times 720$ .

increased number of basophils is due to an increase in compact cells which are oval or round.

The McManus (1946) PAS reaction for the demonstration of glycoproteins in histologic sections initiated researches based on the idea that this reaction might demonstrate the hormone content of basophil cells. Herlant (1949, 1951) and Pearce (1949, 1951) ascribed the reaction given by basophil granules to the presence of gonadotrophin. Catehpole (1949) found in castration cells and in certain basophil cells of normal animals glycoproteins which could have been gonadotrophins. He looked for but did not find glycoprotein with the solubility of thyrotrophin in thyroidectomy cells. He considered that the glycoprotein

staining did not parallel the staining with aniline blue.

Purves and Griesbach (1951a) set out to test the hypothesis that the PAS reaction could be used to demonstrate the hormones of basophil cells by examining rat hypophyses in which thyrotrophin or gonadotrophin or both were absent. Such hypophyses were obtained by treatment of intact rats with thyroxine or estrogen or both thyroxine and estrogen. In hypophyses that contained only thyrotrophin the glycoprotein reaction and the aniline blue-stained granules were confined to cells that were polyhedral in shape and were distributed throughout the interior of the pars anterior. In hypophyses containing only gonadotrophins the glycoprotein reaction and the aniline blue-stained

ules were confined to cells that were ovoid or spherical. The most conspicuous staining was in cells in the periphery of the pars anterior, especially on the inferior surface and at the anterior margin. In hypophyses which contained neither thyrotrophin nor gonadotrophin basophil cells could not be demonstrated by either the glycoprotein reaction or aniline blue.

These results showed that the different hormones were stored in the granules of different cells and that the hormone content was proportional to the granule content. Any staining method which demonstrated the granules would give the same result and, had the Dempsey and Wislocki (1945) suggestion that aniline blue stained the hormones been followed up, results similar to those obtained by the PAS reaction would have been obtained. The PAS reaction provided a more specific staining for basophil granules; its more important role, however, was the psychologic stimulus it gave to investigations relating staining to hormone content because there was a chemical reason for supposing that this reaction would demonstrate the content of thyrotrophin and gonadotrophins.

Purves and Griesbach (1951a) gave the name "thyrotrophs" to the cells whose granules contain thyrotrophin and the name "gonadotrophs" to the cells whose granules contain gonadotrophins.

Halmi (1951a, b) applied Gomori's (1950) aldehyde-fuchsin to the staining of the pars anterior and obtained the distinction between  $\beta$ -cells and  $\delta$ -cells that had previously been obtained by Romcis (1940). It was soon established that the  $\beta$ -cells of the rat pars anterior are thyrotrophs (Purves and Griesbach, 1951b; Halmi, 1952a).

Restaining procedures demonstrate that the same cytoplasmic granules are revealed by aldehyde-fuchsin, phosphotungstic acid-aniline blue, and the histochemical reaction for glycoprotein. The specific staining of the thyrotrophs is therefore a specific staining of thyrotrophin-containing granules. In rats which have been treated with thyroxine the granulation is reduced to such a low level that the thyrotrophs cannot be demonstrated by any of the staining procedures (Purves and Griesbach, 1951c; Halmi,

1951b, 1952b). In rats which have been thyroidectomized there is a rapid discharge of thyrotrophin which reduces the granule content in the cells to a low level. There is simultaneously a marked increase in the number of functioning thyrotrophs and an increase in the size of the individual cells. The total hormone content of the gland is affected in opposite directions by these two effects, and may not be greatly different from normal despite a low concentration of the hormone in the cell cytoplasm. Under these conditions staining by aldehyde-fuchsin is not obtained although the cytoplasm and the hyaline substance are still stainable by other methods. The thyrotrophs, therefore, after thyroidectomy are easily confused with  $\delta$ -cells although they are still clearly differentiated from  $\delta$ -cells by their characteristic shape (Purves and Griesbach, 1951b).

The specific staining of thyrotrophin-containing granules by aldehyde-fuchsin constitutes a notable advance in the study of the functional aspects of pituitary morphology. The differentiation of thyrotrophs from other cells by Halmi's (1951a) method clarifies not only the study of thyrotrophic function, but also that of gonadotrophic functions in the rat pituitary because the two types of basophils concerned with the secretion of the gonadotrophic hormones appear as  $\delta$ -cells which can be studied without confusion with thyrotrophs.

It was soon apparent (Purves and Griesbach, 1952; Siperstein, Nichols, Griesbach and Chaikoff, 1954) that the gonadotrophs in the rat pars anterior are of two types. The peripheral gonadotrophs near the surface of the anterior lobe and especially concentrated on the inferior surface and at the anterior border show a consistently different appearance from the paler rounded cells which are scattered throughout the interior and are the only basophils adjacent to the pars intermedia (Fig. 3.9).

This suggests the hypothesis that one form secretes FSH and the other LH. The central gonadotrophs are the more active-looking cells after castration and during pregnancy. There was therefore a conflict between the at one time current view that after castration the secretion is predominantly follicle-stimulating and the proba-

bility that the hormone secretion during pregnancy is predominantly luteinizing. After a year of investigation it was realized that the solution lay in getting rid of one of the hormones.

Treatment of the adult female rat with testosterone propionate had been shown to increase the gonadotrophin content of the hypophysis and to produce a gland which contains FSH without any admixture of LH (Laqueur and Fluhmann, 1942; Greep and Chester Jones, 1950).

Purves and Griesbach (1954) found that in female rats treated with 250  $\mu$ g. of testosterone daily for 1 week there was a large increase in the numbers of gonadotrophs of both types which could be stained by the glycoprotein reaction. After 3 weeks treatment, the pale central gonadotrophs were found diminished in size and showed signs of diminishing activity. After 4 weeks treatment, the central gonadotrophs had practically disappeared whereas large numbers of the peripheral type with a strong cytoplasmic glycoprotein storage remained. These peripheral gonadotrophs did not seem to be actively secreting because the cells themselves were small.

These observations seem to indicate with certainty that the peripheral type of gonadotroph is exclusively the site of formation and storage of FSH, whereas the central type is probably concerned with the formation and storage of LH.

It has not yet been possible to obtain rat hypophyses containing LH without FSH. In glands containing large amounts of LH there are always large numbers of richly granulated central gonadotrophs and there is no reason to think that the granules of these cells contain any other hormone.

The cells that secrete and store within their granules FSH are called FSH cells; the cells that secrete and store within their granules LH are called LH cells.

As yet, no consistent staining difference between the FSH granules and the LH granules has been obtained. The Wilson and Ezrin (1954) technique differentiates between thyrotrophs and gonadotrophs, the former being PAS-red whereas the latter tend to be PAS-purple. The granules of the thyrotrophs have little affinity for acid dyes and do not take up either the orange G or

methyl blue applied as counterstains to sections which have first been stained by the PAS reaction. Their color is therefore a magenta red. Cells with a strong affinity for acid dyes take up orange G and hold it firmly. Strongly acidophilic basophils (amphophils) of this kind are found among the  $\beta$ -cells of the human pars distalis; they appear brick-red after the Wilson and Ezrin staining method, the color resulting from the addition of orange G to the PAS color. These cells are also called PAS-red by Wilson and Ezrin. The difference in the two shades of red is visible in Figures 1 and 2 of Wilson and Ezrin's (1954) paper. In basophil cells with an intermediate degree of acidophilia the orange G which is taken up first is displaced more or less rapidly by methyl blue in the next step of the procedure. These cells therefore appear purple. The gonadotrophs of the rat have an intermediate degree of acidophilia and may be stained PAS-purple, but the colors obtained are not independent of the amount of granulation present. In this technique there is a tendency for strongly granulated cells to retain the orange G longer and to appear PAS-red whereas in lightly granulated cells the orange G is more rapidly replaced by methyl blue and the cells appear PAS-purple. The color differentiations obtained by Rennels (1957) and by Hildebrand, Rennels and Finerty (1957) resulted from this effect. In the normal rat the FSH cells are more densely granulated than the LH cells and can be stained PAS-red while the LH cells are stained PAS-purple, but when densely granulated LH cells appear in long term castrates they too are PAS-red. Ten days after castration when both FSH cells and LH cells are only lightly granulated both stain PAS-purple. I have not found any color differentiation between FSH cells and LH cells containing a similar amount of granulation. The conclusions of Hildebrand, Rennels and Finerty concerning the distribution of FSH cells and LH cells are therefore not likely to be correct.

Despite the absence of specific staining, the granules of FSH cells and LH cells can be shown to be different by solubility tests. I have made a considerable number of tests of this kind. The best results have been obtained by perfusion of long term castrate

rats with an ether-saturated isotonic acetate buffer at pH 4.5 or 5. Prussian blue has been added to the perfusion medium so that the completeness of the perfusion can be checked. Under these conditions the glycoprotein of the granules of FSH cells was almost entirely extracted whereas that of the granules of LH cells was to a large extent retained. Assays showed that the buffer extraction removed the FSH and some of the LH; the extracted glands contained LH without FSH. Barnett, Ladman, McAllaster and Siperstein (1956) obtained a similar distinction between the granules of FSH and LH cells by immersing hypophyses in 2.5 per cent trichloroacetic acid. This treatment removed most of the glycoprotein from FSH cells and preserved the glycoprotein of LH cells intact. Assays showed a loss of FSH and a preservation of LH.

I interpret these observations as indicating that basophil granules, like other secretion granules, contain a mixture of proteins and that the glycoproteins of LH-cell granules are less soluble than those of FSH-cell granules. The loss of thyrotrophin and FSH from whole rat hypophyses immersed in 2.5 per cent trichloroacetic acid must be ascribed to inactivation rather than to complete extraction, but it may well be that the preservation of LH under these conditions is related to its insolubility in 2.5 per cent trichloroacetic acid. It should not be inferred however that all glycoproteins either insoluble in, or rendered insoluble by trichloroacetic acid are LH. The conclusion of Barnett, Ladman, McAllaster and Siperstein that FSH often occurs in conjunction with LH should be regarded as unproven.

#### 1. THE PARS ANTERIOR OF THE BAT WITH SPECIAL REFERENCE TO TWO TYPES OF GONADOTROPHS

The pars anterior of the hypophysis of the bat (*Myotis myotis*) has been studied by Herlant (1956a). Five types of cells are distinguished by staining reactions. Two are acidophils and three basophils. Aided by the favorable staining properties of the cells and by the unusual nature of the reproductive cycle, Herlant has been able to make identifications of FSH cells and LH cells in the bat that carry more conviction than the identifications made in the rat.

The distinctive staining of the granules of FSH cells and LH cells in the bat makes it possible to assert that the two types are quite separate, and do not change from one type to another at different times.

The two acidophil types in the bat are: (1) Orangeophils. These are relatively stable throughout the reproductive cycle and are presumed to secrete somatotrophin. (2) Carminophils. These are concentrated in the anteromedian zone. They are in evidence at the time of ovulation, become less prominent towards the end of pregnancy and show intense activity accompanied by a high content of cytoplasmic ribonucleic acid in animals that lactate after parturition. They are considered to secrete prolactin.

The three basophil types are: (1) Irregularly shaped basophils scattered through the pars anterior, staining blue by trichrome methods and with a marked affinity for aldehyde-fuchsin. This type which is relatively stable throughout the reproductive cycle is provisionally identified as a thyrotroph. Its response to disturbances of thyroid function has not been tested.

(2) Basophils concentrated in the anteromedian zone, staining blue by trichrome methods and with a slight affinity for aldehyde-fuchsin. These elements are large and well granulated at the time of estrus in the autumn and continue to show an active appearance throughout the period of hibernation when ripe follicles are in the ovaries. They involute after ovulation in the spring and remain involuted during pregnancy. These cells are identified by Herlant as FSH cells.

(3) Basophils in the posterior two-thirds of the pars anterior which show a marked tendency to retain the red component of trichrome staining methods and are therefore violet or purple but not blue after such procedures. They are brick-red in sections stained by PAS and counterstained with orange G, whereas the other two basophil types which do not stain with orange G are magenta. These cells are greatly hypertrophied through pregnancy but undergo prompt involution after parturition regardless of whether lactation follows. Herlant identifies these cells as LH cells and this identification is in accord with the marked activity of LH cells during pregnancy in

the rat. By immersing bat hypophyses in 10 per cent trichloroacetic acid for 12 hours before fixation Herlant found that the granules of FSH cells were soluble, those of the LH cells insoluble in this medium.

## IX. Corticotrophin: the Problem of Its Origin

### A. BASOPHIL CELLS AND CORTICOTROPHIN

Many attempts have been made to relate corticotrophin secretion to one or other of the specific cell types demonstrable by staining reactions, but the results have generally been inconclusive. The distribution within the anterior lobe of species which show distinct zoning is instructive. Smelser (1944) showed that corticotrophin was more concentrated in the basophil zone of the bovine pars anterior than in the acidophil zone. In the pig pars anterior, in which the zones are much more distinct, I have found that corticotrophin is present in portions of the anteromedial basophil zone that are apparently free from acidophil cells, the concentration there being 2 to 4 times that in the posterolateral acidophil zone. The assays were made by the ascorbic acid depletion method. Giroud and Martinet (1948) found that the adrenal weight-increasing action is predominantly situated in the basophil zone. Rochefort and Saffran (1957) found 4 to 13 times as much corticotrophin in the anteromedial basophil zone of pig and beef hypophyses as in the posterolateral parts of the acidophil zone. Certainly in both cow and pig the corticotrophin is not in acidophil cells. In the cow it may be in either basophils or chromophobes, but in the pig it seems certain that it must be in some type of basophil cell, because there are few chromophobes in the pig pars anterior and a large part of the basophil zone is free of them and consists of basophil cells only.

Halmi and Bogdanove (1951) and Hess, Slade, Ammons and Hendrix (1955) found that the loss of acidophil granules in the thyroxine-deficient rat was not accompanied by any change in the content of corticotrophin in the hypophysis, nor was there any change in corticotrophin output. This indicates that the hormone is not in the

acidophil granules in this species and is probably not formed by acidophil cells.

One indication of the possible nature of the granules to be expected in corticotrophin-secreting cells may be made from the chemical nature of their hormonal product. This polypeptide has some relationship to intermedin, and the amino-acid sequence—methionine, glutamic acid, histidine, phenylalanine, arginine, tryptophan, glycine—is common to both (Landgrebe and Mitchell, 1958). The presence of this structure in corticotrophin may account for its having some intrinsic melanin-dispersing properties. The intermedin-secreting cells of the pars intermedia may in some species have enough specific granulation to distinguish them from chromophobes, but when granules are present they are basophil granules containing glycoprotein and are stainable with aldehyde-fuchsin. We might expect, therefore, that if corticotrophin-secreting cells contain granules they will be basophil granules, although it is not necessary that they should contain such granules.

The origin of corticotrophin from basophil cells has gained a certain degree of acceptance based on the association of basophil cell adenomas with the Cushing syndrome in man. The evidence now is that these basophil cell changes are the result of the action of excess adrenal steroids and are not the cause of the syndrome even in those cases which seem to be due to excessive secretion of corticotrophin. This aspect of the subject is dealt with more fully in the later section on Cushing's syndrome.

The attempt by Marshall (1951) to demonstrate the presence of corticotrophin in basophil cells by the use of labeled antibody must be discussed, because it has been regarded by some as a conclusive demonstration of the relation of this hormone to basophil cells. The antibody labeled with a fluorescent grouping demonstrated the presence in basophil cells of an antigen which had been contained in the crude corticotrophin preparation used. There is, however, nothing to associate the antigen so demonstrated with the corticotrophin. Such protein-containing preparations of corticotrophin seem to contain many more molecules of protein than of corticotrophin.

and the antigen could therefore have been one of the glycoprotein hormones known to be antigenic, or some nonhormonal constituent. The absence of evidence of antigenicity in corticotrophin would make the method inapplicable for this hormone unless it could be shown that the hormone was associated in the gland with a specific protein. There is no evidence so far that this is the case, because under certain circumstances the hormone is dialyzable from crude pituitary extracts (Tyslowitz, 1943; Geschwind, Hess, Condliffe, Evans and Simpson, 1950), and in the extract it seems to be distributed indiscriminately among most of the proteins present (Astwood, Raben and Payne, 1952).

In the rat three types of basophil cells have been identified, and the question arises whether one of these secretes corticotrophin in addition to its specific glycoprotein hormone. The hypothesis that thyrotrophs may secrete corticotrophin has attracted some attention and has been subjected to specific investigation. Halmi and Bogdanove (1951) concluded that corticotrophin was not produced by thyrotrophs in the rat. In the pig hypophysis I have found, as Smelser (1944) found in the bovine hypophysis, that the distribution of the hormones between the basophil and acidophil zones is quite different for corticotrophin and thyrotrophin, the latter being almost exclusively in the basophil zone. This seems to make it certain that the same cell does not produce these two hormones.

The problem of the origin of corticotrophin thus seems to resolve into a choice between two alternatives: either corticotrophin is made by gonadotrophs, or it is made by an additional specific cell type, the "corticotroph." Inasmuch as five specific cell types have been identified in the pars anterior of the rat and the bat, the search for an additional cell type which could be the corticotroph may be referred to as the search for a sixth cell type. Investigations aimed at the solution of this problem usually take the form of examining hypophyses in which corticotrophin secretion is proceeding at an abnormally rapid rate, and looking for cellular responses either in sections stained by methods which reveal acidophils and basophils or in sec-

tions stained by unconventional methods which might stain the granules of a sixth cell type not revealed by conventional methods.

#### B. HYPOPHYSEAL RESPONSES TO ADRENAL ABLATION

Many reports of the cytologic changes observed after bilateral adrenalectomy have been published. Some observers have not remarked on any extensive alteration. Thus, Nicholson (1936) did not observe any change in the pars anterior of dogs after bilateral adrenalectomy, and Koneff, Holmes and Reese (1941) found that in rats to which sodium chloride was administered after adrenalectomy, cytologic changes were minimal. Houssay (1952) also remarked that in strains of rats which survive in good condition after adrenalectomy there is little hypophyseal disturbance compared with those which have severe insufficiency symptoms.

It therefore seems that the increased secretion rate or the depletion of the adrenocorticotrophin content of the hypophysis which follows adrenalectomy need not be accompanied by any marked change in the appearance after staining by the customary methods.

Certain changes in the acidophil and basophil cells which are observed in certain strains of rats after adrenalectomy, if additional salt is not administered, must be related to the extensive metabolic disturbances produced by the adrenal insufficiency. These changes have been described by Reese, Koneff and Akimoto (1939). Changes in the acidophil cells consist of degranulation with a diminution in the size and number of cells. The Golgi body in these regressing acidophils is transformed from the usual acidophil form which envelops half the circumference of the nucleus into a concentrated spherical or oval body. These changes indicate decreased activity. Cells of the basophil class also show extensive degranulative changes with reduction in size and number, but some basophil cells with enlarged Golgi bodies are seen, especially at short intervals after adrenalectomy. Tuchmann-Duplessis (1953) also found that, although most of the basophil cells undergo degenerative changes after



adrenalectomy, there remain always a few active normal-looking cells. Colombo (1948, 1949) reported in rats, after bilateral or unilateral adrenalectomy, a change in basophil cells similar to that occurring after castration and not accompanied by any change in acidophil cells.

Griesbach (personal communication) observed that the LH cells were enlarged after adrenalectomy in the rat. There were also changes in thyrotrophs similar to those produced by exposure to cold. The changes in the thyrotrophs were prevented by thyroxine administration. Knigge (1957) found the thyrotrophs diminished in numbers after adrenalectomy. The gonadotrophs ( $\delta$ -cells of Halmi) were unchanged in numbers but were hypertrophied, and some of them were hyalinized 8 weeks after adrenalectomy. Knigge suggested that the  $\delta$ -cells were the source of corticotrophin.

Rokhlina (1940) tested the effects of combining adrenalectomy with castration in rabbits and rats. In some rats thus treated no castration changes appeared in the basophil cells, whereas in others the transformation was delayed. Adrenalectomy performed on the 30th day after castration had some effect on the further development of castration changes.

Brokaw, Briseno-Castrojon and Finerty (1950) performed unilateral adrenalectomy on rats. By this means a relative adrenal insufficiency should be produced without the extensive metabolic disturbances accompanying complete adrenal deficiency. They observed a temporary increase in the pituitary acidophil cell percentage; the normal pituitary cytology was regained in approximately 50 days.

Herriek and Finerty (1940) found in adrenalectomized fowls an alteration in basophils in the pars distalis, which they correlated with the regression of the testes. The basophils showed progressive vesiculation, the vesicles being filled with hyaline material. They considered these basophils to be in a degenerating state. Mikami (1957) observed a degeneration of both thyrotrophs and gonadotrophs in the fowl after adrenalectomy. In addition there was a degranulation and remarkable enlargement of a third basophil type in the rostral zone of the pars distalis. These cells, design-

ated by Mikami "V cells," were considered to secrete corticotrophin.

In the dog, Mikami (1956) found that the  $\zeta$ -cells of Goldberg and Chaikoff (1952a) increased in number and enlarged in size after adrenalectomy. These were the only cells showing signs of increased activity after adrenalectomy. The  $\zeta$ -cells of Goldberg and Chaikoff are the cells termed "pale" cells by Purves and Griesbach (1957a) and are basophil cells with a low content of granules.

#### C. HYPOPHYSEAL RESPONSES TO STRESS

An increased secretion of corticotrophin is produced in response to many different kinds of stress. Inasmuch as adaptation to various kinds of stress will involve changes in a number of hormones, the hypophyseal responses to stress will be less suitable for the study of corticotrophin production than the specific disturbances produced by adrenal insufficiency. Thus, the response to cold exposure involves increased secretion of thyrotrophin as well as corticotrophin, and the increased activity in the basophil cells of the rat exposed to cold have been related to thyrotrophin production rather than corticotrophin (Brolin, 1945; Allara, 1953; McNary, 1957). In rats exposed to cold, Griesbach, Hornabrook and Purves (1956) observed partial degranulation of thyrotrophs and early hyalinization giving rise to cells with a resemblance to Crooke's cells. This appearance is related to alteration in thyrotrophin secretion and can be prevented by thyroxine injections, but not by replacement with cortisone.

An increased granule content in basophil cells in the rat during inanition has been related to an increased storage of gonadotrophin (Pearse and Rinaldi, 1950). The increase in stainable basophils observed in the hypophyses of animals subjected to various forms of stress may, therefore, be related to changes in the content of the glycoprotein hormones which are the specific secretory products of these cells. Herlant (1936a, b) observed that the increase in stainable basophils in the rat hypophysis after ligation of the ureters or after the injection of hydrochloric acid, was accompanied by an increase in the gonadotrophic potency of the pituitary tissue.

Finerty and Binhammer (1952) and Finerty, Hess and Binhammer (1952) studied the early responses of the hypophysis to the acute stress of severe burns in the rat. No changes were observed in the differential cell counts nor in the degree of specific granulation of the cells stained by the azan method. There was, however, an increase in the number of acidophil cells per field in sections stained by the acid hematein method of Remmels (1951). Timmer and Finerty (1956) supplied the explanation of this discrepancy. The results of azan staining were expressed by differential cell counts and did not show any change. The results of the acid hematein staining were expressed as cells per field, and the increase in this number was the result of a shrinkage in the gland which occurred after scalding. Thus, although there were no more acid hematein stained cells in the hypophysis, they were closer together after scalding.

Knigge (1955) found, in thyroidectomized animals in which acidophil granules were absent, that there was no acid hematein staining before or after scalding.

#### D. THE SIXTH CELL TYPE

The pars anterior of the rat is particularly reactive to changes in the rate of hormone secretion, and the absence of any striking change in the stainable cells after adrenal ablation suggests that corticotrophin may be secreted by chromophobes in this species, or that corticotrophin is secreted by a different mechanism from that responsible for the secretion of other anterior lobe hormones. The discovery by Farquhar (1957) of a sixth cell type in the pars anterior of the rat may provide an explanation of these peculiarities. These cells, which can be clearly seen only by electron microscopy, are very different from any of the other five types. The cytoplasm is relatively empty and contains few formed elements (mitochondria, endoplasmic reticulum). Secretory granules are absent.

A distinctive feature of this additional cell type is its location throughout the anterior lobe in groups around follicles or ductules which contain colloid of low density. Some follicles are large and undoubtedly are analogous to colloid cysts, but small follicles which probably could not

be distinguished by light microscopy are much more numerous. The cells lining the follicles have angular contours, and the nucleus is eccentrically located. The amount of colloid seems to vary with the amount of corticotrophin in the gland, being increased after cortisone injection and decreased after partial adrenalectomy. No marked response of the cells to the stimulation of partial adrenalectomy was observed. The identification of this sixth cell type as a corticotroph can only be regarded as tentative. Farquhar suggested that corticotrophin may be stored in the form of colloid and released by some mechanism similar to that by which thyroid hormone is mobilized from the colloid of the thyroid follicles. This would explain the difficulties in relating corticotrophin secretion or storage to changes in the granulated cells observed by the light microscope.

My own observations show that this cell often has an extremely irregular shape with long and tenuous cytoplasmic projections extending between adjacent granulated cells or deeply indenting their cytoplasm. The cross section of the enclosed space is often elongated, suggesting that this cavity often takes the form of a cleft rather than a follicle or tubular ductule.

### X. The Pars Intermedia and Intermedin Secretion

Intermedin is an adenohypophysial hormone, distinct from the other adenohypophysial hormones. This is evident from the fact that it is formed in a different site. In addition to causing dispersion of pigment in melanophores, intermedin acting over a long time also stimulates the formation or deposition of melanin. Intermedin is secreted by a specific cell type in the adenohypophysis. The recognition of this specific type is simple in most vertebrates because the cells are concentrated into a zone, the pars intermedia.

Evidence of the specific hormone content of the pars intermedia was first obtained by Smith and Smith (1923b) in tests of the different regions of the beef hypophysis, and has been confirmed by Lewis, Lee and Astwood (1937), and Giroud and Martinet (1948).

Intermedin seems to be located in a small

granule fraction in sucrose solution homogenates of pars intermedia tissue, because it sediments with the microsomal fraction on centrifugation (Jeener and Brachet, cited by Herlant, 1952a). In this respect it behaves like the hormones secreted by basophil cells in the pars anterior.

Evidence of specific secretion from pars intermedia tissue is provided by the interesting studies of Allen (1930) and Etkin (1941) in transplantation experiments in tadpoles. Their results indicate that severance of the stalk connection with the hypothalamus removes an inhibiting influence from the pars intermedia cells, and that the resultant hypertrophy and hyperplasia is accompanied by oversecretion of intermedin which produces a permanent blackening of the animals. Etkin (1958) found that the capacity of the pars intermedia to differentiate and secrete was not prevented by transplantation of the epithelial primordium of the pituitary to the tail bud of the wood frog where it developed away from any neural tissue. It was, however, in contact with the neural epithelium before transplantation and before Rathke's pouch had begun to form. Copeland (1943) observed in *Triturus viridescens* that the differentiation of the pars intermedia occurs immediately before the first metamorphosis, and at this time the characteristic pigmentation of the red eft stage begins to appear.

The pars intermedia, unlike the pars nervosa, does not undergo degeneration after stalk section in mammals (Rasmussen and Gardner, 1940; Brooks, 1938; Stutinsky, Bonvallet and Dell, 1950; Barnett and Greep, 1951). Indeed, a hypertrophy of the pars intermedia is usually observed with signs of cellular activation. Fisher (1937) demonstrated that intermedin is still present in the cat hypophysis after the pars nervosa has degenerated after stalk section.

The intensity of specific staining of pars intermedia cells varies with the species. This variation is the result of variation in the quantity of specific granulation. The granulation when present appears to contain glycoprotein, because it gives a positive PAS reaction and is stainable by aldehyde-fuchsin without prior oxidation. The glycoprotein character of the intermedia cell granulation has been demonstrated in the bat by Herlant (1956a) and in the frog by Ortman (1954, 1956c). In both species the granules are stained by aldehyde-fuchsin. I have observed the same staining reactions in the granules of intermedia cells in the cat, dog, sheep, deer, and rat (Fig. 3.16). In the rat the glycoprotein reaction and the aldehyde-fuchsin staining are negative after extraction by perfusion with saline saturated with ether or by immersion in a neutral buffer after acetone treatment. Intermedia cells are, therefore, typical basophil cells contain-

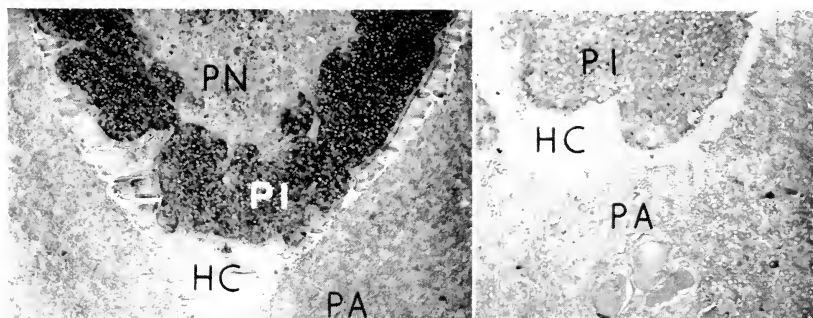

FIG. 3.16 (left). Section of the rat hypophysis showing the staining of the pars intermedia cells by aldehyde-fuchsin (AF). The colloid of the hypophyseal cleft is not stained. PN, pars nervosa; PI, pars intermedia; HC, hypophyseal cleft; PA, pars anterior. Formol sublimate fixation, AF  $\times 43$ .

FIG. 3.17 (right). Section of the rat hypophysis showing the alteration of the staining properties of the pars intermedia by fixation in Helly's fluid. Except for a few coarse granules of unknown nature, the pars intermedia cells are almost unstained in comparison with Figure 3.16. Key to lettering as in Figure 3.16. Helly, AF,  $\times 150$ .

ing granules with a content of soluble glycoproteins. In the rat the granules are much more strongly stained by aldehyde-fuchsin than by PAS, and show an additional difference of behavior from the basophil granules of pars anterior cells in that their staining by aldehyde-fuchsin is not enhanced by prior oxidation with acid permanganate (Halmi and Davies, 1953).

The granules of intermedia cells stain a blue or purple color by trichrome staining methods (Romeis, 1940). In the cat, in which the staining reactions of intermedia cells are strong due to a high content of granulation the appearance of intermedia cells in stained sections is similar to that of typical pars anterior basophils.

The relation between the specific granules and the hormone secretion of the pars intermedia cells is still obscure. The hormone can be obtained as a peptide, but it may be that a combination of this peptide with the glycoprotein is the form in which the hormone is first produced and stored. Ortman (1954, 1956c) found in the frog that the glycoprotein granules of the pars intermedia cells were depleted during dark adaptation, but did not find any accompanying reduction in hormone content.

Not all hypophyses have a pars intermedia, although so far as is known all contain intermedin. In birds as a class, and in certain mammals, porpoise, whale, armadillo, manatee, elephant, pangolin, beaver, and man, the pars intermedia is absent. The problem of the cellular origin of the intermedin in hypophyses of this type is of great interest because of indications that one of the basophil cell types of the human pars distalis is the intermedin secretor of this species. In the porpoise and whale intermedin is present in the tissue of the adenolobe (Oldham, Last and Geiling, 1940), and although the specific cells which produce the hormone have not been identified, it must be assumed that they are present, scattered throughout the pars distalis. A similar distribution of intermedin was shown in the beaver by Kelsey, Sorenson, Hagen and Clausen (1957). In birds the intermedin is found only in the rostral portion of the adenolobe (De Lawder, Tarr and Geiling, 1934; Miallic-Voloss and Benoit, 1954). In

hen and duck hypophyses I have found aldehyde-fuchsin positive basophil cells in the rostral zone of the pars distalis, but the correlation with the distribution of the hormone is obscured by the presence of other aldehyde-fuchsin positive cells in the caudal zone. In the white-crowned sparrow (*Zonotrichia leucophrys gambellii*) aldehyde-fuchsin positive basophils are found only in the rostral zone. Traces of thyrotrophin are present; the concentration is the same in both zones. It may be that the aldehyde-fuchsin positive cells of the rostral zone are the intermedin secretors.

Much more definite information about the human hypophysis is available from the studies of Morris, Russell, Landgrebe and Mitchell (1956). These investigators correlated the hormone content of small portions of tissue from the anterior lobe, neural lobe, and areas of basophil cell invasion in the neural lobe, with the numbers of basophil cells present. The selection of appropriate parts was made by the use of an elegant method in which the presence of basophil cells could be ascertained by examining a pinhead-sized fragment. The results showed that intermedin was present in high concentration in the anterior lobe, whereas it was almost entirely absent from neural lobe tissue. Neural lobe tissue showing invasion by basophil cells was, however, equivalent in hormone content to samples from the anterior lobe. The invasion of the neural lobe by basophilic cells, which is a phenomenon peculiar to the human hypophysis, has permitted here the demonstration that cells containing glycoprotein secrete intermedin. For the identification of the specific type of cell responsible for intermedin secretion in the human pituitary, we can take advantage of the fact that although a number of basophil cell types can be seen in the pars distalis, the cells that invade the neural lobe are of a single type. They are composed entirely of a variety of Romeis' (1940)  $\beta$ -cells which stain with aldehyde-fuchsin and take a red or purple shade from the trichrome counter stain. These cells will be designated as "purple  $\beta$ -cells." Morris, Russell, Landgrebe, and Mitchell (1956) referred to these invading cells as  $\delta$ -cells; they are, however, quite distinctly

characterized as  $\beta$ -cells by Romeis. The  $\delta$ -cells of Romeis do not invade the neural lobe.

The assays of Morris and his associates were concerned with intermedin and corticotrophin, and show that the invading basophil cells were not responsible for corticotrophin production. Although no information is available concerning the other hormones, it is virtually certain that the cells which secrete intermedin in the human will, like the cells secreting intermedin in other vertebrates, be responsible for this secretion only. In man this intermedin secretor is heavily granulated and stains strongly by PAS or by trichrome methods, as does the pars intermedia cell of the cat. It is particularly liable to retain the red stain of the trichrome method, a tendency which is greatly strengthened after fixation in Helly's fluid. Herlant (personal communication) has found that the staining of  $\beta$ -cells in the human pars distalis by aldehyde-fuchsin is greatly diminished or even fails entirely after fixation in Helly's fluid. This behavior of the intermedin secretors of the human pars distalis is also found in the cells of the pars intermedia of the rat, which stain intensely with aldehyde-fuchsin after formol-sublimate fixation but stain very weakly after Helly fixation (Fig. 3.17). It has not been determined whether this behavior is a general one for intermedin-secreting cells.

In the human pars distalis the intermedin-secreting basophils are the most conspicuous of the basophil cells. Their prevalence is consistent with the high intermedin content of the human hypophysis (Landgrebe and Mitchell, 1958). Their failure to respond in sympathy with disturbances of gonadotrophin and thyrotrophin secretion, which has apparently set the human pituitary apart from those of experimental animals, need no longer be a stumbling block now that the nature of these conspicuous basophilic cells is recognized. Obviously the source of thyrotrophin and gonadotrophin must be sought in glycoprotein-containing cells other than the intermedin secretors.

It is possible that some species which have a discrete pars intermedia may also have some dispersed pars intermedia cells in the

pars anterior. Landgrebe, Ketterer and Waring (1955) have referred to such an invasion of the pars anterior in some breeds of pigs.

### XI. The Pars Tuberalis

The pars tuberalis consists of a layer of adenohypophyseal cells which surrounds the neural stalk and covers the surface of the median eminence of the tuber cinereum. It is composed almost entirely of cells of a single type which, from the absence of specific granules of the kind seen in anterior lobe cells, are classed as chromophobes. There are, in addition, small numbers of typical basophil cells which, according to Romeis (1940), do not differ in any respect from the basophil cells of the anterior lobe. Acidophil cells apparently identical with the cells in the anterior lobe are extremely rare. In the larger animals, the pars tuberalis cells are arranged in cords and follicular structures; the latter enclose small amounts of colloid. No specific hormone has been demonstrated in the pars tuberalis other than small amounts of activities probably due to contamination with adjacent anterior lobe or pars intermedia tissue. The function of the pars tuberalis is at present unknown. It may be that it is the source of some trophic influence which is carried to the anterior lobe by the hypophyseal portal system.

### XII. Cytologic Changes Accompanying Secretory Responses Concerned with Reproductive Function

#### A. SEXUAL MATURATION IN THE RAT

Sexual maturation in the male rat is accompanied by a gradually increasing content of glycoprotein in the gonadotrophs. In the female, however, the reaction is entirely different. Maturation is accompanied by a considerable degranulation of gonadotrophs. This degranulation occurred between the ages of 35 and 42 days in the observations of Siperstein, Nichols, Griesbach and Chaikoff (1954), and, in a number of their rats degranulation of the peripheral gonadotrophs which are thought to be follicle stimulating in activity, was found to have preceded the degranulation of the central gonadotrophs. This observa-

tion is significant in view of the fact that the peripheral gonadotrophs ordinarily are more strongly granulated than the central ones. The observation suggests at least that a discharge of stored FSH precedes the discharge of LH on the occasion of the first ovulation.

#### B. SEXUAL MATURATION IN OTHER ANIMALS

Characteristic globular basophil cells first appear in the red eft stage of *Triturus viridescens* simultaneously with the differentiation of the male and female gonads and are presumed to be gonadotrophic (Cope-land, 1943). In the opossum (*Didelphys virginiana*) some interesting observations have been made by Wheeler (1943). A vesiculation of the basophil cells and an accumulation of hyaline material occurs in adult animals after castration, producing cells similar to the castration cells of the rat. Wheeler observed that at 100 days of age there occurs a vesiculation of basophils similar to that produced in adult animals by castration. The assumption is that during sexual maturation the hypophysis is called on to secrete gonadotrophic hormones in large amounts and that before full differentiation of the gonads, a temporary endocrine situation exists similar to that produced by castration.

#### C. SEASONAL BREEDING

In seasonally breeding animals an initiation of the breeding phase has been observed to be accompanied by basophil changes. In the wild cotton-tail rabbit Elder and Finerty (1943) found an increase in gonadotrophic potency in the male hypophysis in the spring, the maximal level being six times that of the level during the winter. This change was accompanied by an increase in the percentage of basophil cells from 4.4 to 13.8. In *Necturus*, Aplington (1942) related the seasonal activity of the testes to an increased activity in the number of granular basophil cells. A similar increased basophil granule content in *Anolis carolinensis* during the spring was observed by Paris (1941).

#### D. INDUCED SEXUAL MATURATION IN THE FEMALE RAT

An important series of observations has been made concerning the effect of estrogen

injections on immature female rats approaching the age of sexual maturation. In the immature female rat gonadotrophin secretion is inhibited by minute amounts of estrogen and as long as this relationship exists, no high estrogen levels can be naturally produced in the animal. With the approach of maturation this inhibiting action of estrogen on gonadotrophin must diminish. Indeed it is found that a condition is reached as the time of the first ovulation approaches when estrogen, instead of inhibiting gonadotrophin secretion, triggers the sudden release of these substances. The physiologic observations of Hohlweg and Chamorro (1937) indicate that a release of gonadotrophic hormones occurred between the second and fourth day after the injection of estrogen into the immature female rat approaching the expected time of first ovulation. The effect of the release of gonadotrophic hormones may be shown by the production of ovulation and corpora lutea or by follicular enlargement only, the actual response being different in different strains of rats. The liberation of the gonadotrophins after estrogen administration results in a marked drop in the hypophyseal gonadotrophin content which occurs approximately between 3 and 4 days after estrogen administration (Bradbury, 1947). Purves and Griesbach (unpublished) have studied the responses of the gonadotrophs of the immature female rat after single estrogen injections and found that regardless of dose in the range from 1 to 100  $\mu\text{g}$ . of estradiol benzoate, there was no change in the hypophysis in the first 2 days. As previously mentioned, in these immature female rats both FSH and LH cells are very numerous and the content of glycoprotein is high. Four days after estrogen administration, the gonadotrophs of the pars anterior are almost free of glycoprotein and can be recognized only with difficulty as large pale cells. It is important to note that at this adolescent stage there is no differential effect of estrogen on peripheral and central gonadotrophs or on the secretion of FSH or LH. The effect is rather that of the triggered discharge of the total gonadotrophin content of the hypophysis.

At the time of glycoprotein discharge from the hypophysis of immature female

rats after estrogen administration, large numbers of mitoses are observed in the chromophobes and granulated acidophils, an effect which is probably due to the action of the injected estrogen on these cells. The number of mitotic figures induced by this single injection of estrogen in the adolescent female rat is much greater than that observed after similar doses in adult animals and indicates that a proliferation of cells of the acidophil class occurs in the female rat hypophysis at the time of maturation. Baker and Everett (1947) found by accurate measurements of mitotic index that stimulation of mitoses in acidophil cells after estrogen administration is greater in immature female rats than in the mature animal.

#### E. THE ACTIVE BREEDING PHASE IN THE FEMALE

The relation between hypophysis and gonad during the breeding phase is quite different from that before maturation. In the rat, with its short estrous cycle, there is a recurrent discharge of gonadotrophins at each ovulation and this maintains the gonadotrophic hormone content at a low level. In accordance with this the gonadotrophs whether studied by the glycoprotein staining reaction or by the Mallory staining reaction are inconspicuous because of the low content of specific granulation. There is during the diestrus an accumulation of specific granulation (Catehpole, 1949; Purves and Griesbach, 1951a). Before the thyrotrophs and gonadotrophs were distinguished, there were observations showing a cyclic change in basophil cells during the estrous cycle. Those by Wolfe and Cleveland (1933a) and Wolfe (1935) revealed a variation of basophil cells in their rats which is in exact agreement with the variations of the specific gonadotrophs (Table 3.2).

The basophil cells observed by Wolfe, which are described as being large, oval, finely granulated, and containing a negative image of the Golgi body in most of the cells, correspond in all details with the LH cells (central gonadotrophs) observed by Purves and Griesbach (1952).

Cyclic changes in the hypophysis of the dog were described by Wolfe, Cleveland and

Campbell (1933) who distinguished in the pars anterior 4 types of cells, 3 of which contained specific granules. Goldberg and Chaikoff (1952a) distinguished 6 cell types of which 4 had specific granules. Type I of Wolfe, Cleveland and Campbell corresponds to the  $\alpha$ -cell; their type II, which is selectively stained by azocarmine (Hartmann, Fain and Wolfe, 1946) corresponds to the  $\epsilon$ -cell of Goldberg and Chaikoff. Type III corresponds in the main to the  $\delta$ -cell, but includes small numbers of cells with a peripheral accumulation of granules which are probably  $\beta$ -cells. The  $\delta$ -cells (type III) increased in numbers up to 10 per cent at the proestrus and were then well filled with fine purplish stained granules. At the time of estrus the number of  $\delta$ -cells was at a maximum (12.6 per cent) but at the same time they showed extensive degranulation. The number of  $\delta$ -cells recognized during the lutein phase of the estrous cycle and during pseudopregnancy was low (2 to 4 per cent), and during the anestrus it was 5 per cent. The variation in number of  $\delta$ -cells and of the granules in these cells corresponds to what would be expected from a cell type producing FSH, if it is right to assume that this hormone is not secreted during pseudopregnancy. Wolfe, Cleveland and Campbell also observed changes in  $\epsilon$ -cells (type II) which, from a level of 5.8 per cent during the anestrus, rose to 7 per cent at estrus and fell during the later lutein phase of the cycle to 2.5 per cent. At this time they also showed considerable degranulation. Present interpretation of these changes would associate the changes in the  $\epsilon$ -cells with the secretion of lactogenic hormone.

Cyclic changes in cells of acidophil and

TABLE 3.2  
(After J. M. Wolfe, *Anat. Rec.*, 61, 321-330, 1935.)

Sexual State	Basophil Cell Percentages		
	Granulated	Nongranulated	Total
Immature (17 days).....	7.2	0.7	7.8
Immature (27 to 35 days).....	7.4	0.9	8.6
Mature (pre-estrus).....	2.8	1.9	4.8
Mature (estrus).....	0.9	4.4	5.2
Mature (metestrus).....	0.6	3.5	4.0
Mature (diestrus).....	1.3	2.7	3.9

basophil classes have also been described in the sow (Cleveland and Wolfe, 1933), rabbit (Wolfe, Phelps and Cleveland, 1934) and guinea pig (Chadwick, 1936). These observations are, however, not easily correlated with hormonal functions because the differentiation of specific cell types was not achieved.

#### F. PSEUDOPREGNANCY AND PREGNANCY

During pseudopregnancy and pregnancy five distinctive cell types are recognizable in the rat hypophysis as follows. (1) Acidophil cells, carminophil by Dawson's (1954a) method, in close relation to blood vessels and connective tissue septa and strongly granulated. (2) Acidophil cells, orangeophil by Dawson's (1954a) method, in the interior of the cell cords and large, active, and only lightly granulated. (3) Thyrotrophs which are more prominent and active in this phase than during the estrous cycle. (4) FSH cells which are strongly granulated and at least as prominent as those in the male hypophysis and in the immature female. (5) LH cells which are large, round, lightly granulated cells with large and prominent negative images of the Golgi body.

In animals treated with thyroxine the thyrotrophs are inhibited and no longer seen. Their activity in the untreated animal is probably an indication of an increased demand for thyroxine during this phase of the reproductive cycle. The strong secretory activity which is indicated in the second type of acidophil cell is considered to be related to the secretion of lactogenic hormone, whereas the activity of the LH cells is considered to be related to a high level of secretion of LH. The prominence of the FSH cells indicates a retention of FSH. The increased prominence of the FSH cells does not necessarily indicate an increased secretion of FSH inasmuch as other conditions which interrupt the estrous cycle permit the accumulation of glycoprotein in these cells. The increased glycoprotein storage correlates with the finding of elevated gonadotrophin levels in the rat hypophysis during pregnancy (Evans and Simpson, 1929; Zeiner, 1952).

The carminophil cell in the rabbit, cat and monkey, shows during the reproductive

cycle marked fluctuations in activity which can be correlated with the secretion of prolactin at times when its luteotropic or lactogenic action is manifest (Dawson and Friedgood, 1937, 1938b; Dawson, 1939, 1948; Friedgood and Dawson, 1940).

#### G. PREGNANCY CHANGES IN THE HUMAN HYPOPHYSIS

In the human hypophysis the predominant change in pregnancy is the activation of large numbers of cells which are chromophobic in the nonpregnant state. These pregnancy cells were first described by Erdheim and Stumme (1909). They lie in the lateral regions of the pars distalis and from the seventh month contain fine acidophil granules. These cells have been the source of some confusion and Rasmussen (1933), finding normal proportions of acidophils, basophils, and chromophobes in the early months of pregnancy, denied the existence of a specific pregnancy cell although he recognized the enlargement of the chromophobes during this condition. Romeis (1940) confirmed the observations reported by Erdheim and Stumme and described the pregnancy cells as large cells with large nuclei. In the second half of pregnancy they show an accumulation of granules which Romeis called  $\eta$ -granules. Romeis considered the  $\eta$ -granules to be a specific type of granule not present in the nonpregnant hypophysis. The granulated pregnancy cell closely resembles the  $\epsilon$ -cell as seen in the nonpregnant human hypophysis although there are some points of difference. The distribution of the granules is similar and the granules, like those in  $\epsilon$ -cells, are orangeophil.  $\alpha$ -Cells, whose granules are carminophil, retain their normal appearance in the pregnancy hypophysis. It is probable that pregnancy cells are  $\epsilon$ -cells in an altered functional state. Floderus (1949) examined the distribution of pregnancy cells in the human hypophysis and found that they are infrequent in the upper posterior part of the pars distalis and are sometimes entirely lacking in this region. They are most abundant in the lower lateral parts of the gland. The pregnancy cells are often centrally located in the cell cords with other types, usually ordinary acidophils, located periph-



erally. Cell cords composed mainly of pregnancy cells occur and isolated cords of this nature may be conspicuous in certain regions. The chromophobes of the vascular zone of the anterior lobe near its attachment to the stalk ("zona tuberalis") are not affected by pregnancy changes. The pregnancy cells are, therefore, not derived from chromophobes in general but from chromophobic cells having a specific distribution.

There are two important differences between human pregnancy cells and the carminophil cells of the rabbit, cat, and monkey. First, the human pregnancy cell granules are orangeophil rather than carminophil. The distinctive color difference between  $\alpha$ -cells and pregnancy cells is, therefore, in the human hypophysis the reverse of that seen in the other species. Second, the distribution is different from that seen in the monkey where carminophil cells are especially concentrated in the zona tuberalis. Despite these differences, the pregnancy cells appear to be functionally analogous to the carminophil cells and are presumably the source of prolactin secretion.

#### H. LACTATION

The characteristic feature of the pars anterior at and shortly after parturition is the increased amount of acidophil granulation present. Kirkman (1937) found in the guinea pig that the acidophils increase in numbers towards the end of pregnancy and attain a maximum soon after parturition. Wolfe and Cleveland (1933b) reported a similar increase in granulation of acidophils in the rat hypophysis towards the end of pregnancy. Everett and Baker (1945) found that after parturition in the rat, the acidophil cells increased by almost 100 per cent in the first three days of the lactation period. This increase in the number of acidophil cells visualized was accomplished without an increased number of mitoses or any increase in the size of the gland and was, therefore, due to the regranulation of acidophil cells which had been degranulated during pregnancy. Hunt (1949), however, found that mitoses were present in some but not all rat hypophyses after parturition. Even allowing for this

latter observation it seems that the increased number of acidophil cells at the time of parturition can be accounted for by the accumulation of secretory granules in the cells of the acidophil class. Purves and Griesbach (unpublished) have found that this increase in granulation occurs in the acidophil cells which are remote from the blood vessels and connective tissue septa and which are considered to be related to prolactin secretion. It has already been noted that in the cat a granulation of carminophil cells occurs which is at its maximum at the time of parturition (Dawson, 1946), these cells also being considered the specific secretors of prolactin. In accordance with this view, Hurst and Turner (1942) reported that in the rat, rabbit, mouse, guinea pig, and cat the prolactin content of the hypophysis was at its highest level during the first few days after parturition.

In connection with the question whether there is a separate lactogenic factor secreted during lactation, different from the luteotropic and mammogenic factor secreted during pregnancy as Turner (1939) postulated, cytologic observations indicate an activity in a single specific cell type associated with both mammary growth during pregnancy and lactogenesis after parturition. There is, during early lactation, a phase of secretory activity in these specialized acidophil cells which is at its maximum about the 16th day of lactation in the cat (Dawson, 1946). Thereafter the reaction wanes in a manner which suggests that a continuation of lactation is not dependent on the continued secretion of this factor. It is, therefore, probable that the continuation of an established lactation in those animals in which lactation is of considerable duration is not dependent on the continued secretion of prolactin. In conformity with this view, prolactin has been found to stimulate metabolic changes in slices of mammary gland tissue from rats on days 1 to 4 of lactation (Folley, 1952). On the other hand, purified prolactin preparations have not shown any galactopoietic effect in the cow during the declining phase of lactation (Folley and Young, 1938).

### XIII. The Human Hypophysis

#### A. STRUCTURE

In the human hypophysis (Fig. 3.18) the adenolobe is closely adherent to the neural lobe. The hypophysial cleft persists in the adult only in its distal portion. The remainder of the cleft is obliterated by fusion or is broken up into a number of scattered colloid-filled cysts.

No pars intermedia is present, consequently the pars distalis adheres to the neural lobe. This feature, which is present also in the higher apes, is not found in lower mammals. In the latter there is either a pars intermedia which is adherent to the neural lobe and separates it from the pars anterior, or there is a pars distalis which is not adherent to the neural lobe. A full description of the structural features present in the

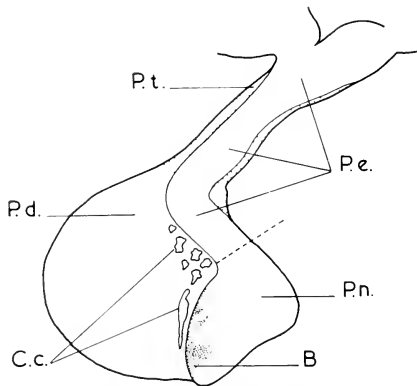

FIG. 3.18. Diagram of a sagittal section through the human hypophysis. The anterior direction is to the left of the diagram. The adenolobe is occupied by pars distalis tissue (*P.d.*) containing a mixed cell population throughout and there is no pars intermedia. Colloid cysts (*C.c.*) occurring in the region adjacent to the neural lobe are probably remnants of the hypophysial cleft. The adenolobe is adherent to the neural lobe. The neural eminence, the neural stalk, and the prolongation of the neural stalk within the neural lobe are here collectively called the pars eminentia (*P.e.*). The pars nervosa (*P.n.*) shows an invasion by basophil cells (*B*) which migrate into the pars nervosa from the pars distalis. The extent of this invasion increases with increasing age and shows great variation in different individuals. The pars tuberalis is indicated by *P.t.*

zone of contact between adenolobe and neural lobe in the human hypophysis is given by Romeis (1940), who reviews the earlier literature on the subject.

An invasion of the pars nervosa by basophil cells derived from the pars distalis is a unique feature of the human hypophysis. In lower mammals possessing a pars distalis such invasion is not possible because of lack of contact between the two parts. The cells of the pars intermedia in the more usual form of mammalian hypophysis do not show this invasion of the pars nervosa, although an irregularity of the plane of contact indicates a tendency for mutual interpenetration of the two tissues. As stated earlier, the cells invading the pars nervosa of the human hypophysis are intermedin-secreting cells.

#### B. SPECIFIC BASOPHIL CELL TYPES IN THE HUMAN HYPOPHYSIS

The treatise of Romeis (1940) constitutes a landmark in the study of the human hypophysis, as indeed for the mammalian hypophysis in general. Romeis' findings in the human hypophysis have, however, despite their completeness and their excellent presentation, not had the influence on the development of this subject that might reasonably have been expected. The availability of fresh pituitary tissue from surgical hypophysectomy has changed this situation. When appropriate fixing and staining techniques are used, results equivalent to those described by Romeis can be consistently obtained, and even those workers who, through the use of inadequate techniques, have deprived themselves of the opportunity of observing the cell types described by Romeis, must accept the conclusion that such cell types are present and can be revealed by appropriate techniques. It is therefore advisable that those who would study the human hypophysis should identify the cells they see with those so clearly delineated by Romeis rather than to embark on schemes of classification which Romeis' results show to be inadequate, or to use the terminology of Romeis in applications other than those which he adopted.

The  $\beta$ -,  $\delta$ -, and  $\gamma$ -cells of Romeis are basophil cells because their granules give a

positive PAS reaction for glycoprotein (Herlant, 1958). Romeis noticed that some of the  $\beta$ -cells retained azocarmine during the azan staining of the sections previously stained with resorcin-fuchsin, whereas others retained only a blue counterstain from the aniline blue. The researches of Griesbach (unpublished) have convinced me that these staining reactions indicate two distinct types of cell whose granules are stained by resorcin-fuchsin, *i.e.*, two types of  $\beta$ -cells. After Helly fixation the difference between the two types is enhanced. Also after Helly fixation the staining of the granules of one type of  $\beta$ -cell by aldehyde-fuchsin is greatly weakened, an effect which allows the red counterstain by azan in this type to be more clearly seen. The  $\beta$ -cells are therefore seen to comprise purple AF cells and blue AF cells. These we may call in the human pars distalis "purple  $\beta$ " and "blue  $\beta$ ." The  $\delta$ -cells are blue non-AF after Helly fixation, and the  $\gamma$ -cells are usually also blue non-AF.

The blue  $\beta$ -cells are more variable in size and shape than the purple  $\beta$ -cells and are more often found in multinucleated form than the latter. Their distribution in the gland is quite different from that of the purple  $\beta$ -cells, so that they cannot be variants of a single cell type. Moreover, the staining reactions of the granules, except to resorcin-fuchsin or aldehyde-fuchsin after certain fixatives, are quite distinctive. There are indeed more dissimilarities between purple  $\beta$ -granules and blue  $\beta$ -granules (Fig. 3.19) than there are between the latter and the  $\delta$ -granules.

Reasons have been given in the section on the pars intermedia and intermedin secretion for regarding the purple  $\beta$ -cells as intermedin-secreting cells corresponding to the pars intermedia cells of the usual mammalian hypophysis. The blue  $\beta$ -cells, the  $\delta$ -cells, and the  $\gamma$ -cells should therefore be homologous with the three basophil cell types in the pars anterior of such mammals as the rat, bat, and dog.

#### C. DIFFERENTIAL STAINING OF BASOPHIL CELLS IN THE HUMAN PARS DISTALIS

The  $\gamma$ -cells of Romeis are distinctive in appearance, containing fine glycoprotein

granules which are stained only feebly by acid dyes (Figs. 3.20 and 3.21). In addition they often contain droplets of glycoprotein, intensely stained by the PAS reaction. These cells have been termed "vesiculate chromophobes" (Pearse, 1952). They are not likely to be confused with normally granulated  $\beta$ -cells or  $\delta$ -cells. The partition of the basophil cells by differential staining of the specific granules is therefore a partition of the purple  $\beta$ -cells, blue  $\beta$ -cells, and  $\delta$ -cells (Fig. 3.22). Some of the methods used produce a differentiation between the purple  $\beta$ -cells and the two types of blue cells. Because it was assumed that only two types of cell were involved, the distinction between purple and blue cells has been assumed to be a distinction between  $\beta$ - and  $\delta$ -cells. Purves and Griesbach (1957b) observing purple and blue cells in Crossman (1937) stained sections of human pars distalis wrongly assumed this to be a distinction between  $\beta$ - and  $\delta$ -cells. Herlant (1953b; 1954b) differentiated the purple  $\beta$ -cells from the other types by counterstaining PAS stained sections with orange G. The orange G stained the strongly acidophilic granules of the purple  $\beta$ -cells and combined with the PAS color to produce a brick-red shade whereas the other basophil granules were magenta. Wilson and Ezrin (1954) used a method substantially the same as Herlant's PAS orange method with the addition of methyl blue. The methyl blue stained only the magenta granules of Herlant leaving the granules of the purple  $\beta$ -cells brick-red. The purple cells of Purves and Griesbach, the brick-red cells of Herlant, and the PAS-red cells of Wilson and Ezrin are obviously the same cells and belong to the group of  $\beta$ -cells. It is only when these staining methods are applied as counterstains to sections in which  $\beta$ -cells have been electively stained by aldehyde-fuchsin, as in the method of Griesbach, that the dual nature of the  $\beta$ -cells is revealed.

Adams and Swettenham (1958) applied aldehyde-fuchsin or Alcian blue to sections oxidized with performic acid and followed this with PAS staining. Their R cells which were red and not stained by aldehyde-fuchsin are the purple  $\beta$ -cells, their S cells which were stained by aldehyde-fuchsin

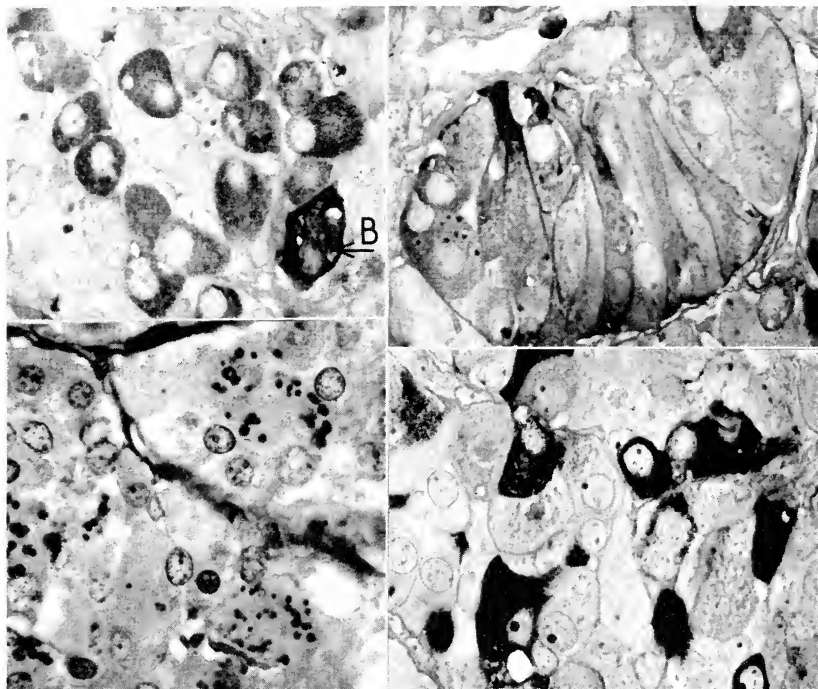

FIG. 3.19 (*upper left*). Section of the human pars distalis showing weak staining of the granules of purple  $\beta$ -cells by aldehyde-fuchsin after fixation in Helly's fluid. Much of the density of the purple  $\beta$ -cells in the photomicrograph is due to the reddish tint given to them by the azan counterstain. A single blue  $\beta$ -cell (*B*) is strongly stained by the aldehyde-fuchsin (AF). In the section it appeared an indigo color from superimposition of a blue color from the aniline blue of the counterstain. AF, azan,  $\times 900$ .

FIG. 3.20 (*upper right*). Section of the human pars distalis showing  $\gamma$ -cells. The cells here show elongated forms. The granulation was stained a weak purplish shade. AF, azan,  $\times 900$ .

FIG. 3.21 (*lower left*). Section of the human pars distalis showing  $\gamma$ -cells stained by periodic acid-Schiff (PAS). The conspicuous PAS +ve droplets which are unusually numerous in this field are not peculiar to the  $\gamma$ -cell since they may be found in other cell types, both basophil and acidophil. The faint grey granulation distributed throughout the cytoplasm is considered to be the specific  $\gamma$ -granulation. PAS,  $\times 900$ .

FIG. 3.22 (*lower right*). Section of the human pars distalis fixed in Helly's fluid and stained with aldehyde-fuchsin (AF), counterstained with azan. Acidophils, blue  $\beta$ -cells and purple  $\beta$ -cells which were deeply stained in different colors in the section, appear black and cannot be clearly distinguished from one another in the photomicrograph. The numerous large rounded pale cells with grey granulation are  $\delta$ -cells. The granules were stained a clear blue in the original. AF, azan,  $\times 900$ .

Alcian blue comprise the blue  $\beta$ - and  $\delta$ -cells. Herlant (1956b) obtained the same distribution of the aldehyde-fuchsin stain in sections oxidized with permanganate. It is to be noted that the effect of oxidation is to inhibit the staining of purple  $\beta$ -cells by aldehyde-fuchsin and to render the  $\delta$ -cells

stainable; the blue  $\beta$ -cells are stained with or without oxidation. The effects of permanganate oxidation on the aldehyde-fuchsin staining of the human pars distalis are the same as those observed in the pars anterior and pars intermedia of the rat (Halni and Davies, 1953). The staining of the pars

intermedia cells is weakened and the  $\delta$ -cells of the pars anterior become stainable whereas the  $\beta$ -cells remain stainable. The difference between the species is that the intermedin-secreting cells in the human hypophysis are scattered throughout the pars distalis and not segregated in the pars intermedia.

Hellweg (1951) obtained by silver impregnation a specific staining of the  $\delta$ -cells in the human pars distalis. This staining is similar to that observed by Knigge (1957) in the rat, in which a specific staining of Halmi's  $\delta$ -cells (gonadotrophs) was obtained by silver impregnation. Ezrin, Swanson, Humphrey, Dawson and Wilson (1958) obtained specific staining of  $\delta$ -cells by their iron-PAS method, the  $\delta$ -cell granules being stained by dialyzed iron which is subsequently converted to Prussian blue. A valuable feature of the iron-PAS method is that it is applicable to postmortem material fixed in formol-saline.

#### D. FUNCTIONS OF THE BASOPHIL CELLS OF THE HUMAN PARS DISTALIS

##### 1. *The $\delta$ -Cell*

Neither Hellweg (1951) nor Ezrin, Swanson, Humphrey, Dawson and Wilson (1958) found  $\delta$ -cells in children before the age of puberty, and the latter investigators did not find them in the hypophyses of pregnant women. This finding can be correlated with the reduction in gonadotrophin content during pregnancy (Herlant, 1943). It is therefore certain that the  $\delta$ -cells are the source of one or more of the hypophysal gonadotrophins. Ezrin and his associates found that the number of  $\delta$ -cells decreases with the duration of the terminal illness, being 8.5 per cent in patients dying in 24 hours and 1.8 per cent in those dying after 2 weeks or longer. This is in accordance with other evidence suggesting a reduction in gonadotrophin during chronic illness.

##### 2. *The Blue $\beta$ -Cell*

There is a considerable increase in the number of hypertrophied, lightly granulated basophil cells in myxedema and cretinism (Herlant, 1954b, 1958). The staining reaction of these cells to Herlant's (1953b)

PAS-orange method indicated that they are blue basophils, and inasmuch as Russell (1957) found them stainable by aldehyde-fuchsin it is probable that they are blue  $\beta$ -cells and not  $\delta$ -cells as Herlant supposed. The blue  $\beta$ -cells are therefore probably thyrotrophs. It should be noted that the staining reactions of the blue  $\beta$ -cells are the same as those of the thyrotrophs of the pars anterior of the rat, dog, bat, cat, and guinea pig.

##### 3. *The $\gamma$ -Cell*

$\gamma$ -Cells are well developed and fully functional in appearance in children and maintain much the same appearance in women up to the menopause. They do not seem to be altered in appearance during pregnancy (Herlant, 1958). They are quite distinct from pregnancy cells which in the latter half of pregnancy contain acidophil granules. The number of  $\gamma$ -cells does not show any correlation with the duration of the terminal illness (Ezrin, Swanson, Humphrey, Dawson and Wilson, 1958). Herlant's observation that the  $\gamma$ -cells are inactive in aged subjects does not correlate with any known change in hormone secretion. It is possible that these cells secrete corticotrophin but more investigation is necessary. Crooke and Russell (1935) noticed in Addison's disease a variable proportion of very large "chromophobes." Large chromophobes ("hypertrophic amphophils") have also been observed by Mellgren (1945, 1948) in this disease. The large chromophobes or hypertrophic amphophils of the above authors are presumably the  $\gamma$ -cells of Romeis (1940), or more precisely the remains of the  $\gamma$ -cells, inasmuch as these cells are susceptible to post-mortem autolysis and are not well preserved in autopsy material. Griesbach (private communication) has observed a large number of large  $\gamma$ -cells in the pars distalis of a patient who had been adrenalectomized for the treatment of a carcinoma some weeks before death.

#### E. THE AMPHOPHIL CELLS OF RUSSELL

Russell (1957) divides the cells of the human pars distalis into acidophils, basophils, amphophils, hypertrophic amphi-

phils, and chromophobes. The acidophils of Russfield are the  $\alpha$ -cells of Romeis, the basophils are the conspicuous and strongly granulated  $\beta$ -cells of Romeis. Russfield erroneously considers these "normal" basophils to be the  $\delta$ -cells of Romeis. The amphophils consist of lightly granulated cells— $\delta$ -,  $\gamma$ -, and  $\epsilon$ -cells—but may include  $\alpha$ - and  $\beta$ -cells if these are lightly granulated. Hypertrophic amphophils are in the main  $\gamma$ -cells whose cytoplasm and granules have been lost by postmortem autolysis, to which these cells are especially sensitive.

From the study of hypophyses of patients with endocrine disturbances (Burt

and Velardo, 1954) and of hypophyseal tumors (Russfield, Reiner and Klaus, 1956), Russfield concludes that amphophils are capable of producing all the anterior lobe hormones, but there is no implication that they produce all these hormones simultaneously. This seems to mean no more than that large amounts of hormone may be secreted by lightly granulated cells. Russfield's results are of importance in directing attention to the fact that more information of endocrinologic significance can be obtained from the study of lightly granulated cells than by the enumeration of "typical" acidophils and basophils; they do not conflict with the view that the cells producing different hormones are characterized by different types of granules, whose specific character can be distinguished by appropriate staining methods.

#### F. THE PURPLE $\beta$ -CELL IN THE CUSHING SYNDROME

The purple  $\beta$ - or intermedin-secreting cells are only lightly granulated in infants. The amount of granulation in these cells as measured by the intensity of the PAS reaction increases with age in a smooth continuous fashion which is neither accelerated nor retarded by puberty or the menopause (Herlant and Lison, 1951). The cells are not affected by pregnancy and the progressive increase in granule content follows the same course in both sexes.

The functional state of the purple  $\beta$ -cells appears to be determined by the level of circulating corticosteroids and has not been shown to be related to any other factor. Although the physiologic significance of the responses of the purple  $\beta$ -cells to variations in the corticosteroid level is concealed in the mystery which envelops the whole subject of the function of intermedin secretion in mammals, the responses themselves are definite, striking, and consistent. High levels of corticosteroids stimulate, low levels depress the cytologic activity of these cells.

The characteristic changes in the Cushing syndrome are a degranulation and hyalinization of the purple  $\beta$ -cells. The changes were first described by Crooke (1935), after whom the hyalinized cells were named (Fig. 3.23). In my own observations I have found that it is only the purple  $\beta$ -cells

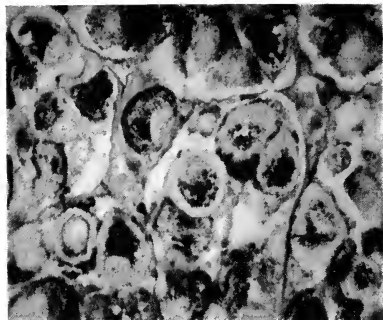

FIG. 3.23 (upper). Section of the pars distalis of a patient who suffered from the Cushing syndrome. Many typical Crooke's cells are present. The hyalinized zones appear homogeneous at this magnification. The remaining granules are stained in the manner typical of purple  $\beta$ -cell granulation. AF, azan,  $\times 900$ .

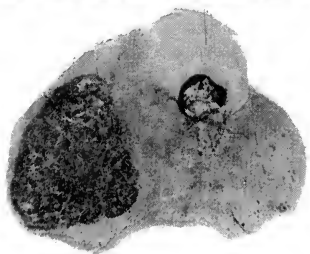

FIG. 3.24 (lower). Section of a human hypophysis showing a basophil adenoma composed of cells with the staining reactions of purple  $\beta$ -cells. In material fixed in formalin the purple  $\beta$ -cells are strongly stained by aldehyde-fuchsin (AF). From a specimen supplied by Professor Dorothy Russell. AF,  $\times 5$ .

which are affected by hyalinization. Moreover, the basophil cells which invade the neural lobe and are all purple  $\beta$ -cells are sometimes hyalinized in the same way as the cells in the pars distalis. Hyalinization does not alter the staining reactions of the granules that remain in the hyalinized cells. It is notable, however, that the purple  $\beta$ -cells which have invaded the neural lobe are normally less active and smaller in size than those that remained in the pars distalis. This difference in activity persists in the Cushing syndrome and, in consequence, the purple  $\beta$ -cells in the neural lobe show a lesser degree of hyalinization than those in the pars distalis; they may indeed not show any hyalinization in hypophyses in which many of the cells in the pars distalis are affected.

Degranulation of Crooke's cells may be complete and the cytoplasm may be completely hyalinized. More characteristic is a partial degranulation having an annular distribution. The periphery of the cell may be granulated and the granules be preserved around the nucleus and Golgi body, or degranulation may occur around the nucleus and Golgi body with preservation of granules at the periphery. Sometimes a degranulated zone occurs with preservation of granules both at the periphery and in proximity to the nucleus and Golgi body. Hyalinization occurs in the degranulated zone and differs from the mature hyalinization of thyrotrophs and most gonadotrophs in the rat, in that the hyaline area is not sharply limited. The surface of the hyalinized zone shows a fine vesicular structure which gives to the hyalinized zone a faintly ground-glass appearance. Probably the hyalinization is similar to that of the filigree cells described by Farquhar and Rinehart (1954) in the rat.

The hyaline substance is not colored by the PAS reagent and has little affinity for basic dyes.

Crooke's cells are in general large cells with vesicular nonpyknotic nuclei and easily visible Golgi bodies. Both McLetchie (1942a, b) and Mellgren (1945) agree with Crooke that these appearances indicate increased secretory activity.

In the original description of the Cushing

syndrome the presence of a basophil adenoma in the hypophysis was noticed in three cases. Cushing emphasized the role of these adenomas as a primary factor in the causation of the syndrome, but considered it possible that the symptoms were due to stimulation of adrenocortical secretion by the basophil adenoma (Hubble, 1949). However, such basophil adenomas are not found in all cases of the syndrome and are, moreover, not infrequently found in hypophyses of persons in the older age groups who have not exhibited any specific endocrine disturbances during life.

The cells of basophil adenomas found in association with Crooke's cells contain basophil granules with the same staining reactions as those of purple  $\beta$ -cells (Fig. 3.24). The cells of the adenomas are usually not hyalinized. In this respect they are similar to basophil adenomas induced in the rat hypophysis by thyroxine deficiency or by castration. The association of basophil adenomas with hyalinization indicates a long continued strong stimulation of the affected cells (Purves, 1956).

#### G. CROOKE'S CELL CHANGES PRODUCED BY CORTICOSTEROID OR CORTICOTROPHIN ADMINISTRATION

Laqueur (1950, 1951) and Thornton (1956) have reported Crooke's cell changes in patients treated with cortisone. Golden, Bondy and Sheldon (1950), Dreyfus and Zara (1951), and Thornton (1956) have also reported similar changes after treatment with corticotrophin. The corticotrophin presumably acts by stimulating the adrenal cortex, the secretion from which is the effective agent in producing the hyalinization. From Thornton's observations it appears that hyalinization is produced in a few days by effective doses of corticosteroids and regresses equally rapidly after cessation of treatment. Crooke's cells therefore indicate a high level of corticosteroids in the circulation in the last few days before death. The erroneous assumption that the basophil cells which were hyalinized in the Cushing syndrome were pars anterior cells caused some investigators to postulate that the hyalinization was the expression of an increased secretion of thyrotrophin or gonad-

otrophin resulting from alterations of thyroid or gonadal function produced by high levels of corticosteroids. The fact that these cells are not hyalinized in myxedema or after castration shows that this is not so. In the present state of knowledge it seems probable that Crooke's cells are actively secreting intermedin, the effects of which are antagonized by corticosteroids. Only occasionally is the Cushing syndrome associated with hyperpigmentation (Edmunds, McKeown and Coleman, 1958). It can be affirmed that Crooke's cell changes have nothing to do with an increased secretion of corticotrophin because they are produced by conditions which cause suppression of corticotrophin secretion.

#### H. CHANGES IN THE PURPLE $\beta$ -CELLS IN ADDISON'S DISEASE

Reports on the human pars distalis in Addison's disease indicate a diminution in the number of basophil cells or at least a scarcity of well granulated basophils (Kraus, 1923, 1926, 1927; Berblinger, 1932; Crooke and Russell, 1935). It is the purple  $\beta$ -cells which disappear, apparently passing into an inactive state in which they lose their granules. Blue basophils remain apparently in a normal state and it is these cells which have been referred to as Crooke-Russell cells. This interpretation is in conformity with the staining reactions of Crooke-Russell cells reported by Russell (1956) and by Wilson and Ezrin (1954). Presumably both blue  $\beta$ - and  $\delta$ -cells are present; the material at my disposal has not been suitable for differential staining of these cell types.

In view of the inactivity of the purple  $\beta$ -cells in Addison's disease, the hyperpigmentation in this condition must be ascribed to the intrinsic melanocyte stimulating activity of the corticotrophin which is being secreted in excessive amounts. Perhaps it is the effects of this side reaction of corticotrophin which cause suppression of intermedin secretion in this condition.

#### I. THE PHARYNGEAL HYPOPHYSIS

The pharyngeal hypophysis is a collection of cells found in the submucosa of the posterior pharyngeal wall and is a remnant of

the epithelial stalk of the hypophysis which connects the buccal ectoderm to Rathke's pouch at an early stage of embryonic development. The pharyngeal hypophysis is found only in man and seems to be constantly present (Romeis, 1940). It is a mass of cells 3 to 4 mm. in length. The cells are mainly small with scanty cytoplasm, but larger chromophobes and occasional acidophils are present. Basophil cells are extremely rare.

It has been suggested that the pharyngeal hypophysis can take over some of the function of the sellar hypophysis when the latter is destroyed by disease processes (Tönnis, Müller, Ostwald and Brilmayer, 1954; Müller, 1958). This cannot be regarded as established for the residual function may be traceable to pars distalis cells that have escaped destruction.

The pharyngeal hypophysis is sometimes the site of adenoma formation (Müller, 1958). Erdheim (1926) described a case of acromegaly in which was found an unaltered sellar hypophysis and an acidophil adenoma derived from the pharyngeal hypophysis.

#### IV. Electron Microscopy of the Adenohypophysis

Many cytologic structures are so small that the details of their structure cannot be made out by means of the light microscope, the resolving power of which is limited to about 300  $m\mu$ . The limit of resolution of the electron microscope is about 1 000 that of the light microscope. Because of the low electron density of organic materials and the consequent lack of contrast in thin sections of tissues, the available resolution of the electron microscope for cytologic detail is limited to about 1 50 of that of the light microscope, *i.e.*, about 6  $m\mu$ . This is a big advance, comparable to that produced by the change from the simple hand lens to the compound microscope.

The most fertile application of electron microscopy in the field of cytology has been the examination of ultrathin sections of tissues fixed in solutions containing osmic acid. Osmic acid has been for many years considered the best fixative for the preservation of fine structure in material exam-



ined by light microscopy. Its use is unfortunately incompatible with most of the staining techniques on which light microscopists have come to rely. For the fixation of tissues for light microscopy, use has been made of a number of fixatives, which permit subsequent staining by various methods, but which do not satisfactorily preserve fine structure even at the level visible by light microscopy. These fixatives cause an extensive redistribution of the proteins of cells during fixation as is shown by an increase in opacity and light scattering power during fixation.

No exact correspondence can be expected between the appearances of structures seen in electron micrographs of osmic acid fixed tissues and of structures rendered visible by staining in tissues fixed by other methods.

Cytoplasmic structures visible in electron micrographs of adenohipophyseal cells (Figs. 3.25-3.32)<sup>1</sup> include the endoplasmic reticulum, the components of the Golgi region, the Palade granules, mitochondria, secretion granules, and lipid droplets. Thus far electron microscopic observations of the pituitary have revealed nothing new with respect to the finer structures of these parts (Palade, 1953), and nothing that is suggestive of specific hypophyseal function. On the other hand, only a first step has been taken, but it is expected that further studies will lead to clarification of the many problems to which allusion has been made.

#### A. ENDOPLASMIC RETICULUM

The endoplasmic reticulum is a cavity system consisting of tubes, vesicles, and flattened sacs interconnected by narrower

channels to form a complicated network (Palade, 1956). The system is enclosed by a continuous membrane which is probably similar to and derived from the cell membrane (Howatson and Ham, 1957). The endoplasmic reticulum varies considerably in extent and form in different cells. When it is extensive the cross-sections of its membrane-enclosed cavities may occupy the greater part of the cytoplasm. The membranes are not revealed by any staining methods used in light microscopy and the cavity usually contains no stainable content. In consequence light microscopy gives little indication of the existence of the endoplasmic reticulum. The larger vesicles which form part of the endoplasmic reticulum of the basophil cells of the rat pars anterior are, however, visible in paraffin sections examined by light microscopy and confer on the cytoplasm a foamy appearance which was noted by Reese, Koneff and Waiman in 1943. Under conditions of rapid secretion, hyaline substance accumulates in these vesicles which become much more easily visible by reason of their enlargement and the presence of a stainable content. That hyalinization is an accumulation of a stainable material in cytoplasmic vesicles which are always present but normally empty was first stated by Reese, Koneff and Waiman and confirmed by the electron microscope studies of Farquhar and Rinehart (1954a, b). Electron microscopy did not therefore provide the first evidence for the existence of the endoplasmic reticulum, but it showed for the first time its full extent, its continuity, and its existence in all types of cells.

#### B. THE GOLGI REGION OR ZONE

The Golgi region or zone has long been a focal point of discussion by investigators of pituitary morphology and function (Severinghaus, 1932, 1933, 1939). In suitable preparations studied by light microscopy it is often seen as a conspicuous feature of granulated cells in the pars anterior, this specialized region of the cytoplasm being made evident by the absence from it of the granulation which is distributed throughout the remainder of the cytoplasm. In sections which are sufficiently thin, an unstained zone is seen producing an appearance with

<sup>1</sup>The electron micrographs of the cells found in the pars anterior and pars intermedia of the rat were contributed by Dr. Marilyn G. Farquhar who also supplied the descriptions. The electron micrographs, which were specially prepared for this publication are, as a result of recent technical advances, of higher quality than those appearing in the original publications. All were prepared from tissues fixed in osmium tetroxide buffered with acetate-veronal buffer to pH 7.4 and embedded in *n*-butyl methacrylate. Sections of 20 to 50  $\mu$  were prepared with a Porter-Blum microtome (Servall) and examined and photographed in an RCA EMU-2 electron microscope. Further technical methods are detailed elsewhere (Farquhar, 1956).

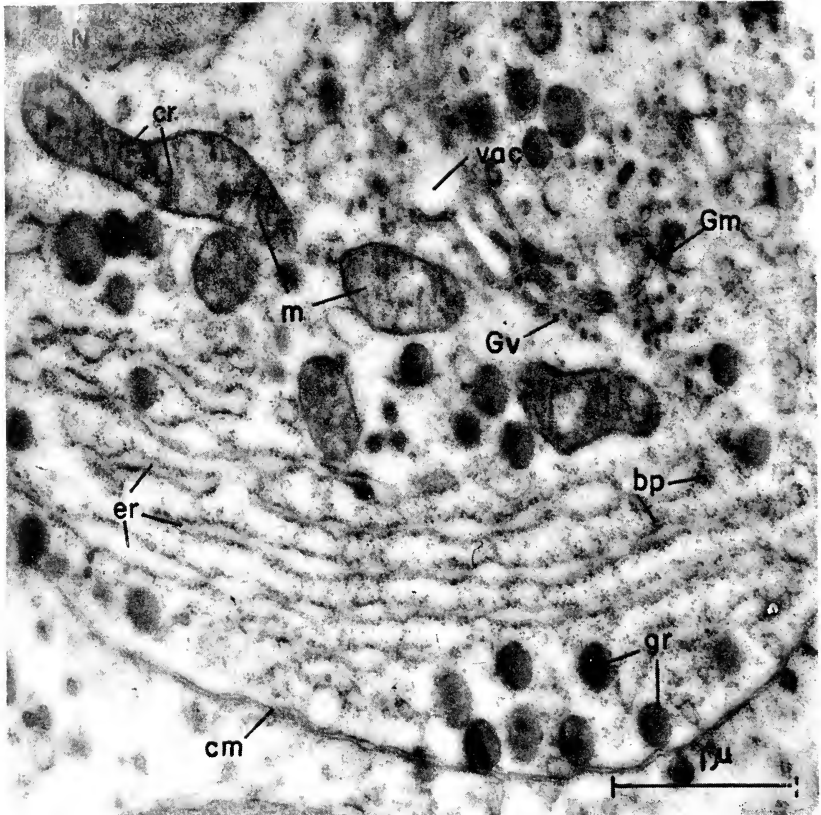

FIG. 3.25. Electron micrograph showing a portion of an adenophil from the adenohypophysis of a rat. Part of the nucleus (*N*) is present above and a segment of the cell membrane (*cm*) crosses the field below. A few dense ovoid secretory granules (*gr*) are scattered throughout the field. Several mitochondria (*m*) are also seen. They show double-layered limiting membranes and internal cristae (*cr*) or "cristae mitochondriales" of Palade (1952) which are characteristic features of all mitochondria.

The endoplasmic reticulum (*er*) is seen in the lower portion of the cell. This cytoplasmic component occurs here in the form of parallel rows of long, membrane-limited sacs. When reconstructed in three dimensions the sacs are continuous with one another at the ends, and the membranes thus enclose a broad flat cavity. These appearances represent just one organizational variant of this highly complicated system (Palade and Porter, 1954).

A number of tiny dense particles (*bp*) (ca. 100Å) are distributed throughout the cytoplasm, but are particularly concentrated along the membrane surfaces of the endoplasmic reticulum. These particles are generally considered to be the site of localization of cytoplasmic ribonucleoprotein (Palade, 1955).

Components of the Golgi apparatus can also be identified in the cytoplasm. In electron micrographs the Golgi "complex" may be resolved into 3 components: relatively empty-appearing vacuoles (*vac*) of varying sizes (Dalton and Felix, 1951; Sjöstrand and Hanzon, 1951; Faruq, 1956); paired membranes (*Gm*) (ca. 7 *mμ* each) (Palade, 1952); small granules or vesicles (*Gv*) (ca. 10 *mμ*) (Palade and Porter, 1951). × 31,500.

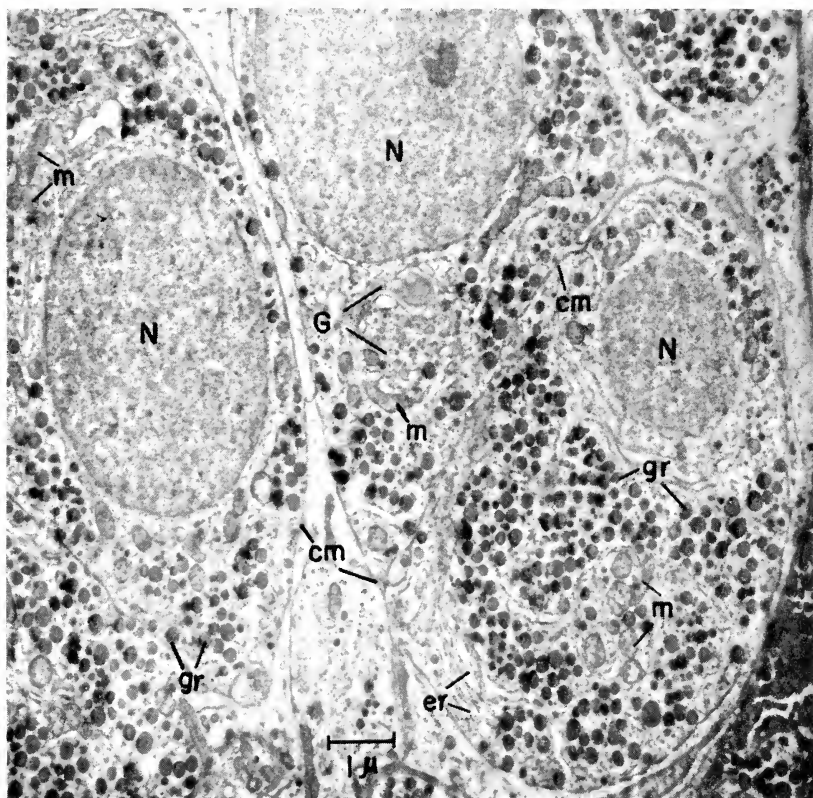

FIG. 326. Electron micrograph showing cells from the anterior pituitary of a young adult male rat. Three acidophils of the type which are thought to be responsible for the production of growth hormone (Hedinger and Farquhar, 1957; Farquhar and Rinchart, 1954a) occupy most of the field. Their nuclei (N) are indicated.

This type of acidophil is characteristically rounded or ovoid in shape, and the cells typically are arranged in groups, as shown here. In electron micrographs the most distinctive feature is their content of variable numbers of dense, ovoid secretory granules (*gr*) of a characteristic size (ca. 350 m $\mu$  maximal diameter). Large numbers of secretory granules are present in this field. The cell membranes (*cm*) can be clearly seen separating the cytoplasm of one cell from that of another. Mitochondria (*m*), endoplasmic reticulum (*er*), and Golgi material (*G*) may also be distinguished.  $\times 10,300$ .

is termed "the negative image of the Golgi body." The negative image of the Golgi body or zone is especially conspicuous in the basophil cells of the rat pars anterior. In acidophil cells the Golgi body is usually smaller and the negative image is not seen unless the sections are thin, *i.e.*, 2 to 3 $\mu$ . When acidophil cells are stimulated their Golgi zones become enlarged and the nega-

tive image may be seen more easily. This happens in the rat hypophysis after estrogen treatment or at times when rapid secretion of the lactogenic hormone is occurring physiologically. The Golgi region has the appearance of a spheroidal shell enclosing an area of cytoplasm. In the basophil cells of the rat pituitary, the cytoplasm enclosing the Golgi region is more deeply stained.

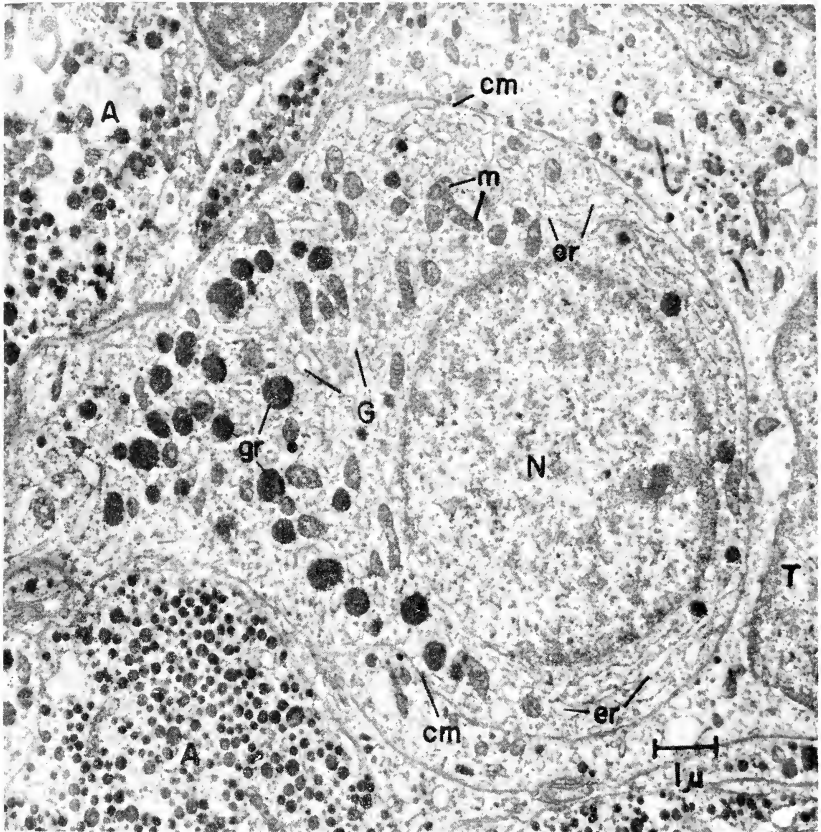

FIG. 3.27. Electron micrograph of a section from the anterior pituitary of a normal, young adult female rat showing an acidophil of the type which is thought to be responsible for the production of mammothrophic hormone (Hedinger and Farquhar, 1957; Farquhar and Rinehart, 1954a). The nucleus (*N*) and the cell membrane (*cm*) of the mammothroph are shown.

These cells are typically found alone, rather than in groups, in the normal, nonlactating animal. Their most distinctive feature in electron micrographs is their cytoplasmic content of very large, dense secretory granules (*gr*) with a maximal diameter of 600 to 900  $\mu$ . In this cell they are predominantly found grouped to the left of the nucleus (*N*). The granules appear very dense and do not show evidence of internal structure. Their appearance is in contrast to that of the mitochondria (*m*) which are usually more elongated, much less dense, and show clear internal structure which is difficult to see in detail at this relatively low magnification.

Tubular and cisternal (elongated) profiles of the endoplasmic reticulum (*er*) as well as vacuoles of the Golgi complex (*G*) may also be identified in the cytoplasm. The two areas marked *A* represent segments of the cytoplasm of two adjacent acidophils of the type which are presumed to be responsible for the production of growth hormone. The smaller size of the secretory granules distinguishes these cells from the mammothrophic acidophil.

A portion of the nucleus of a thyrotroph (*T*) is seen to the right. Cytoplasmic processes of this cell extend out from the nucleus to encircle partially the mammothroph. The cell may be identified as a thyrotroph on the basis of its angular shape and content of very small secretory granules.

In the lactating animal acidophils of this type with large secretory granules are very numerous and can be seen in virtually every field (Hedinger and Farquhar, 1957).  $\times 11,700$ .

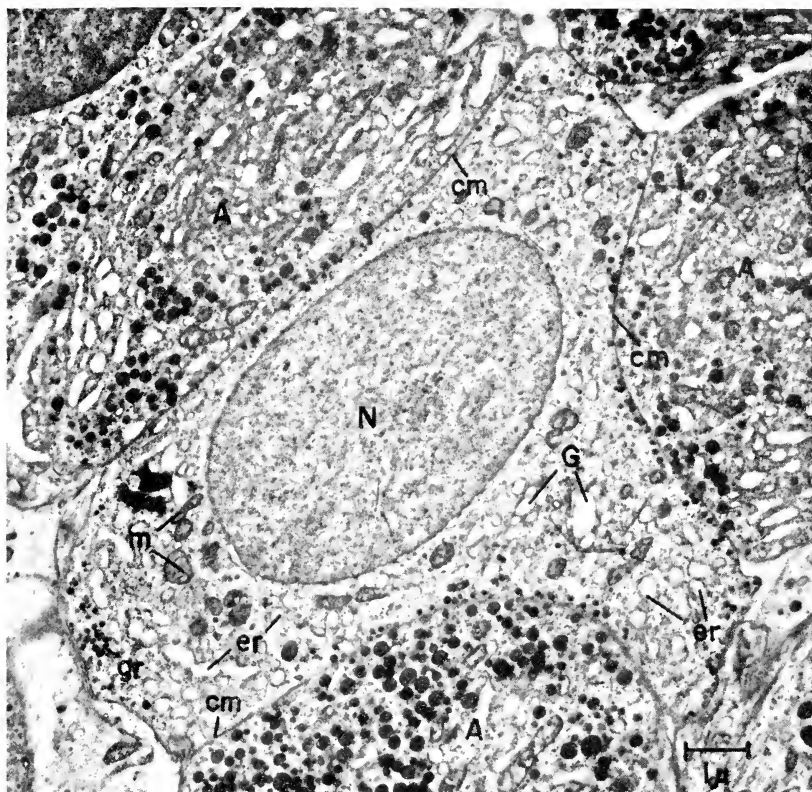

FIG. 3.28. Electron micrograph showing a thyrotroph from the anterior pituitary of a young adult male rat. The nucleus (*N*) and cell membranes (*cm*) are indicated. The irregular contour characteristic of thyrotrophs is illustrated in the angular shape of this cell.

In electron micrographs thyrotrophs can be distinguished by virtue of the size of their secretory granules which are smaller (maximal diameter ca.  $100 \mu\mu$ ) than those in any other type of anterior lobe cell (Farquhar and Rinehart, 1954b). In this cell the secretory granules are found, for the most part, lined up along the cell membrane.

As seen in this cell, the endoplasmic reticulum (*er*) of thyrotrophs is generally present in the form of small vesicular profiles with occasional elongated (cisternal) profiles. The mitochondria (*m*) usually occur in the form of short rods and show a background matrix which is much less dense than the internal matrix of gonadotroph mitochondria (see Figs. 3.29 and 3.30). A group of vacuoles of the Golgi complex (*G*) can also be distinguished in the cytoplasm of the thyrotroph.

The thyrotroph is virtually surrounded by acidophils of the growth hormone type. The cytoplasm of these cells is labeled *A*. The size of their secretory granules (maximal diameter ca.  $350 \mu\mu$ ) can be contrasted with the smaller thyrotroph granules.  $\times 10,000$ .

the rest of the cytoplasm. The PAS reaction shows that this is due to a greater concentration of glycoprotein granules in the enclosed cytoplasm. The appearance of the darkly stained cytoplasm within the negative image of the Golgi body has not always

been interpreted correctly and some investigators have mistaken it for an early stage of hyalinization.

Severinghaus (1932, 1933) reported in the rat the Golgi apparatus of the thyrotroph of the acidophil class has a different

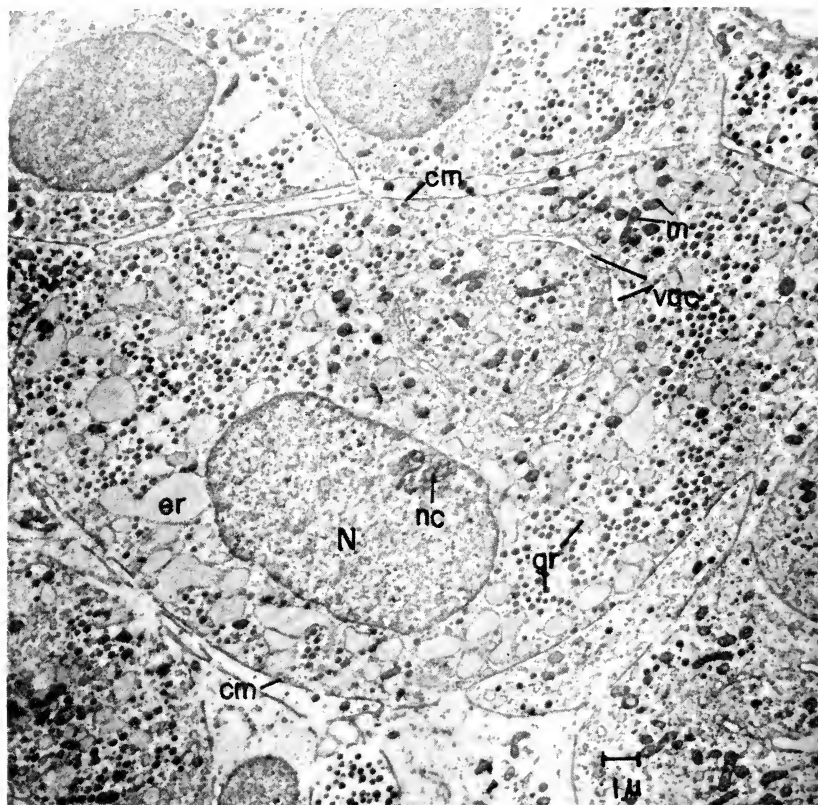

FIG. 3.29. Electron micrograph showing a very large gonadotroph from the anterior pituitary of a young adult male rat. The nucleus (N), a nucleolus (nc), and the cell membrane (cm) are shown.

This cell can be identified as a gonadotroph by virtue of its rounded contours and content of secretory granules (gr) with a maximal diameter of approximately 150 m $\mu$ . The secretory granules of gonadotrophs are intermediate in size between the large secretory granules of acidophils and the small secretory granules of thyrotrophs.

A spherical chain of small vacuoles (vac) circumscribes the Golgi apparatus which is located above the nucleus. Elements of the Golgi complex outline a cytoplasmic area nearly as large as the nucleus.

Mitochondria (m) which have been sectioned in various planes are also visible in the cytoplasm. The mitochondria of gonadotrophs are generally more elongated and show a denser internal background matrix than other types of adenohypophysial cells.

The endoplasmic reticulum (er) is seen here in the form of numerous vesicles which vary greatly in size. Some are relatively small and are of a size approaching that of the secretory granules. Others are rather large, for they measure several microns across at their greatest width. It can be seen that the interior of the vesicles appears homogeneously grey, and has a background density greater than that of the surrounding cytoplasmic matrix.

Gonadotrophs with this appearance have been associated with the secretion of follicle-stimulating hormone (Farouhar and Rinchart, 1954a; Farouhar and Rinchart, 1955). They differ from the luteinizing hormone-gonadotroph (see Fig. 3.30) in possessing somewhat paler nuclei, more evenly distributed granules, and prominent vesicles of the endoplasmic reticulum with the homogeneous grey interior.  $\times 6500$ .

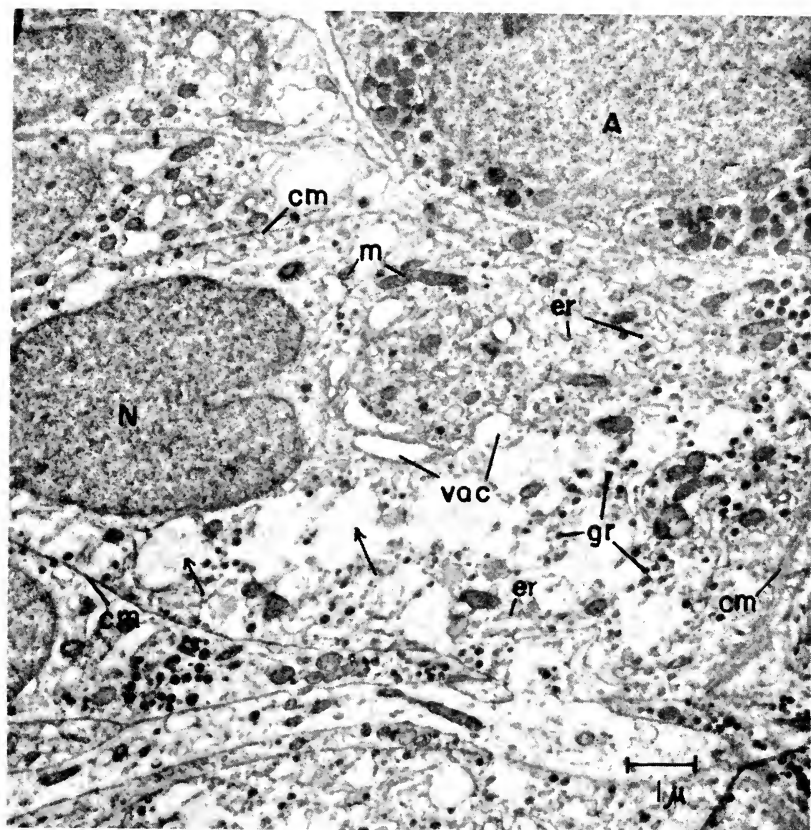

FIG. 3.30. Electron micrographs illustrating another gonadotroph from the anterior pituitary of a young adult male rat. Like the cell in Figure 3.29, this cell can be identified as a gonadotroph on the basis of its rounded contours, the size of its secretory granules (maximal diameter ca.  $150 \mu\mu$ ), and elongated mitochondria ( $m$ ) with a dense internal matrix. The area occupied by the Golgi complex is seen directly to the right of the nucleus. It is outlined by a number of relatively empty-appearing vacuoles ( $vac$ ).

This gonadotroph differs from the follicle-stimulating hormone gonadotroph illustrated in Figure 3.29 in several respects: the nucleus ( $N$ ) is more dense and shows a deep infolding, the secretory granules ( $gr$ ) are aggregated into clumps, and no large vesicles of the endoplasmic reticulum are present. In addition, there are a number of relatively open areas visible in the cytoplasm (arrows) which are occupied only by a sparse, flocculent precipitate. The endoplasmic reticulum ( $er$ ) is seen here in the form of tiny tubular profiles. Gonadotrophs with these features have been associated with the secretion of luteinizing hormone or interstitial cell-stimulating hormone (Farquhar and Rinehart, 1954a; Farquhar and Rinehart, 1955).

A portion of an acidophil ( $A$ ) with larger secretory granules is present above the gonadotroph.  $\times 11,700$ .

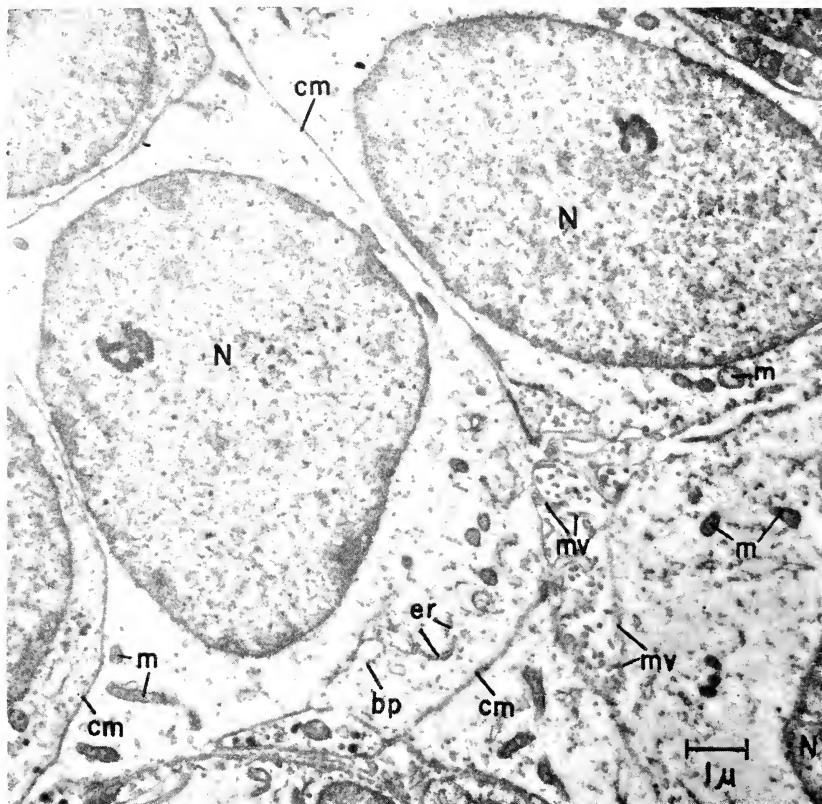

FIG. 3.31. Electron micrograph illustrating portions of several cells which were recently suggested to be concerned with the formation of adrenocorticotrophic hormone (Farquhar, 1957). Two large nuclei (N) and a segment of a third nucleus are shown.

Such cells are typically found in groups and are arranged around large follicles or smaller ductiles. Some of the follicles are quite large, measuring several microns across and are undoubtedly analogous to so-called "colloid cysts" sometimes seen in the anterior lobe by light microscopy. Other follicles, such as the one illustrated here, are quite small and would probably escape detection by light microscopy.

The cells which line the follicles or ductiles typically show tiny cytoplasmic projections or microvilli (*mv*) which project into the follicular lumina. In this field portions of three cells abut on the follicle and form microvilli which project into the lumen.

The follicular cells characteristically do *not* contain secretory granules. Furthermore, in the normal animal their cytoplasm appears relatively empty, for organized cytoplasmic structures are sparse. Only a few mitochondria (*m*), occasionally tubular profiles of the endoplasmic reticulum (*er*), and basophilic particles (*bp*) are encountered.

In terms of their somewhat monotonous regularity, these cells resemble more closely the cells from the intermediate lobe than they do any other type of anterior lobe cell.

Because of the response of these cells to alterations in adrenal activity and their lack of response to other experimental procedures, it has been tentatively suggested (Farquhar, 1957) that these cells are responsible for the formation and/or transport of corticotrophin.  $\times 10,800$ .



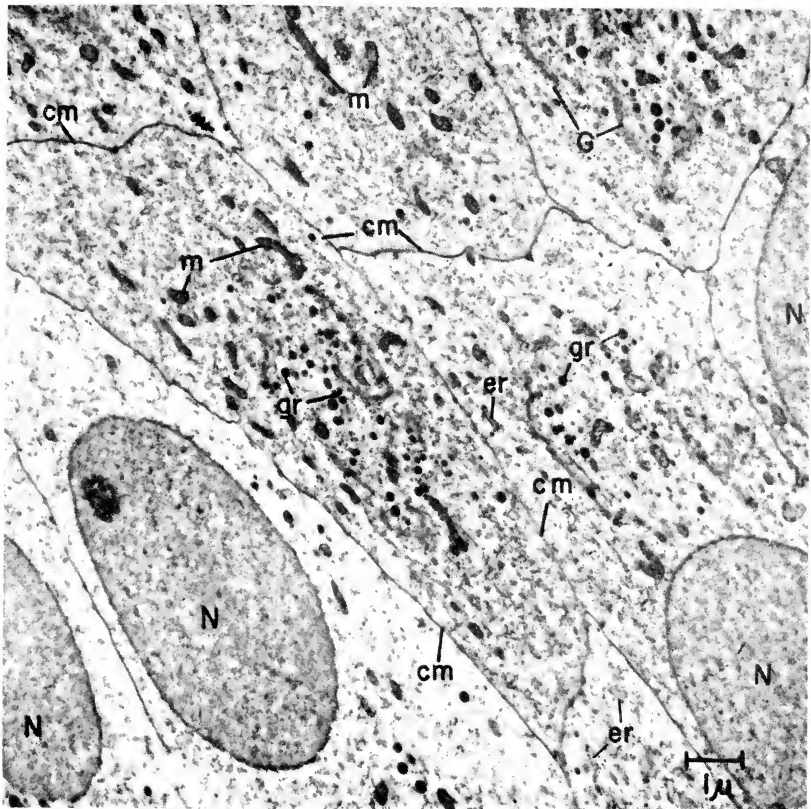

FIG. 3.32. Electron micrograph showing a field of cells from the pars intermedia of the rat pituitary. The plane of section passes through the nuclei (N) of four of the cells, whereas only the cytoplasm of several other cells is transected. The cell membranes (cm) stand out prominently.

These cells are seen to fit together like a mosaic, and they all show a similar appearance. Their cytoplasm contains relatively few secretory granules (gr) and mitochondria (m). The endoplasmic reticulum (er) is present in the form of tiny vesicular profiles with occasional tubules. Elements of the Golgi complex (G) are visible in several areas. In these cells the dense, paired Golgi membranes and granules predominate over Golgi vacuoles, which are not seen at all in this field.  $\times 9100$ .

from that of the cells of the basophil class. In the acidophil cells the Golgi apparatus forms a net-like cap extending over one pole of the nucleus, whereas in the basophil cells it has the appearance of a spheroidal body lying in the cytoplasm at some distance from the nucleus. These characteristic differences were confirmed by Foster (1947) using the Sudan black staining method.

Among the chromophobes some cells have Golgi bodies similar to those of the granulated acidophils, whereas in others they are similar to those of the granulated basophils. This suggests that the chromophobic cells are not undifferentiated, rather that they consist in part at least of temporarily non-functioning but specifically differentiated cells.

The characteristic appearance of the Golgi body of the "normal" acidophil cell of the rat hypophysis is not retained through all the phases of activation which may be experienced by this cell. Wolfe and Brown (1942) found that in the hypophysis of the rat treated with estrogen the Golgi body of the acidophil cells enlarged and became more or less spheroidal in shape so that acidophil cells could no longer be distinguished from basophil cells on the basis of the Golgi body appearance alone. The change of the acidophil type of Golgi body from the paranuclear net to a rounded body is not confined to conditions of strong activation but is also seen after castration when the acidophil cells are undergoing a reduction in number and a shrinkage in cell and nuclei size.

In mammals other than the rat distinct differences in the form of the Golgi body in different cell types have not been described, although there are distinct differences in the relative size of the Golgi bodies in different cell types. In the lizard, *Anolis carolinensis*, (Poris, 1941) the Golgi bodies in the acidophil and basophil cell classes are different, but in this species, unlike the rat, the type of Golgi in the acidophil cells is the more compact one.

Electron microscopic studies of thin sections reveal that the Golgi zone is a system of smooth membranes enclosing spaces which appear to communicate with the endoplasmic reticulum. In Palade's (1955) account of the fine structure of nerve cells, the components of the Golgi region were termed "agranular reticulum." There is an association of three distinct structures: (1) A system of double membranes formed by the apposition of flattened vesicular structures. (2) A system of microvesicles with a dense content. (3) Large empty membrane-enclosed spaces ("vacuoles") resulting from the section of a hollow structure with a watery content.

The relationship of the three components to one another and to the classical Golgi apparatus or network is not entirely clear but it is likely that the "vacuoles" are cross-sections of an anastomosing canalicular system (Dalton and Felix, 1953; Lacy, 1954) which is responsible for the appearance of

the negative image of the Golgi zone. The demonstration of a network by osmium impregnation (Nassonov, 1923) is in the main the result of precipitation of osmium outside the canalicular space particularly at the site of the system of double membranes (Dalton and Felix, 1956; Gatenby and Lufty, 1956).

Electron micrographic studies have clarified to some degree the relationship between the Golgi zone and secretory activity. The Golgi zone is not a region in which synthesis of proteins or peptides occurs. The Golgi complex appears to be concerned rather with the segregation or removal of water from maturing secretory products (Dalton and Felix, 1956) and the enclosure of the mature product in membranes to form secretory granules (Farquhar and Wellings, 1957). The establishment of other relationships awaits other efforts. Particularly promising are the techniques developed by Peterson (1957) for identifying in stained sections the same fields seen in electron micrographs of the adjacent section.

#### C. PALADE GRANULES

Palade granules are dense bodies 10 to 15  $\mu$  in diameter. They occur to some extent either singly or in clusters in the cytoplasm but are for the most part attached to the membrane of the endoplasmic reticulum forming in those regions where they occur a "rough-surfaced" membrane (Palade, 1955, 1956). Although much too small to be visible as granules under the light microscope, their existence, although not their form, can be made evident by specific staining. The granules contain ribonucleic acid and are therefore responsible for cytoplasmic basophilia. They figure in the literature of light microscopy as a substance, cytoplasmic ribonucleic acid or Nissl substance, and not as a structure. In certain secreting cells in which rough-surfaced membranes occur as closely packed, flattened sacs they are responsible for the appearance termed "ergastoplasm" by Garnier (Palade, 1955).

#### D. SECRETORY GRANULES

Secretory granules are spheroidal membrane-enclosed bodies with a dense homogeneous content. The granules in different

cell types differ in size and in the density of their content. The specific differences in the chemical nature of the contents of secretory granules in different cells cannot yet be made apparent by electron microscopy. The electron microscope emphasizes the essential similarity of the specific granules of acidophil and basophil cells and indeed of secretory granules generally whether in endocrine or exocrine cells.

Lipid droplets are seen in electron micrographs as dense bodies, their density being no doubt the result of precipitation of osmium by the reducing action of the lipid. They are irregular in outline, probably as a result of solution of the lipid and distortion during dehydration and embedding. The lipid droplets do not have an enclosing membrane.

Farquhar and Rinehart have identified in electron micrographs the five granulated cell types which can be distinguished by light microscopy in the pars anterior of the rat. All five contain the same cytoplasmic structures; there is no distinctive structural element peculiar to any of the types. There are differences in the shape of the cells, in the extent and form of the endoplasmic reticulum, and in the size, density, and distribution of the secretory granules which enable the different types to be distinguished from one another.

The secretory granules of the basophil cells are less than 200  $m\mu$  in size. Although such granules can be seen individually under good optical conditions with the light microscope, the coarsely granular or flocculent appearance of the cytoplasm of basophil cells in stained sections is produced by the uneven distribution of the fine granules which are not individually resolved. The "basophil granules" of the basophil cells of the rat pars anterior as seen under the light microscope therefore bear the same relationship to the secretory granules as the Nissl granules of nerve cells bear to the Palade granules; they are in fact clusters of granules made visible by the staining of their specific content.

#### E. MICROVILLI

In addition to the granulated cells the pars anterior of the rat contains cells with

a distinctive structural feature, namely, microvilli projecting from the free surface of the cell into a space which is enclosed by contiguous cells of the same type. These cells are not accessible to study by light microscopy and their appearance is so different from that of known endocrine cells that their function must be admitted to be problematical.

## XV. The Neurohypophysis and Neurohypophysal Secretion

### A. NEUROSECRETORY PHENOMENA IN THE HYPOTHALAMUS AND NEUROHYPOPHYSIS

Neurohypophysal tissue contains connective tissue, nonmyelinated axons, and interspersed neuroglial cells. In the neural eminence and neural stalk the axons run more or less parallel to one another and, although some of the axons terminate in these regions, most of them pass into the neural lobe where they end in the pars nervosa. The terminal enlargement which forms the neural lobe results in part from the branching of the axons in the terminal part of their course, in part from the increased number of glial cells in this region of the neurohypophysis.

In fish and amphibia the axons in the neurohypophysis arise from cells in the preoptic nucleus in the hypothalamus and form the preopticohypophysal tract in the intrahypothalamic part of their course. In reptiles, birds, and mammals the homologue of the preoptic nucleus is separated into two parts, the supraoptic nucleus and the paraventricular nucleus. The axons of the neurons in the paraventricular nucleus pass towards the supraoptic nucleus and after running through or closely alongside this structure join the supraopticohypophysal tract (Laqueur in discussion, Scharrer and Scharrer, 1954). Lesions which are produced experimentally to destroy the supraoptic nuclei or interrupt the supraopticohypophysal tract also interrupt the paraventriculohypophysal fibers and produce a total neurohypophysal deficiency. It therefore appeared at one time that neurohypophysal activity in mammals was entirely dependent on the supraoptic nuclei alone, but it is now clear that the paraventricular

tricular nuclei have the same function as the supraoptic nuclei, being spatially separated parts of the same functional unit.

The organ responsible for neurohypophysial secretion is thus more extensive than the neurohypophysis. It includes in addition the supraoptic and paraventricular nuclei and their tracts. Functionally we may distinguish four separate regions in this hypothalamo-neurohypophysial system. The first region contains the supraoptic and paraventricular nuclei in which the neurohypophysial secretion is elaborated. The second contains the paraventriculo- and supraoptico-hypophysial tracts which serve two functions, the conduction of nerve impulses and the physical transport of neurohypophysial secretion into the neurohypophysis. The third region is the tissue of the neural eminence, neural stalk, and in some species a portion of the neural lobe, which are in this account referred to collectively as the pars eminentis. In this tissue some of the axons terminate, usually in relation to blood vessels (Scharrer and Scharrer, 1954; Scharrer, 1954) and mediate a secretory activity which could by virtue of the vascular link between this region and the pars anterior or pars distalis, modify the function of the adenohypophysis. In some amphibia a very considerable proportion of the preopticoneurohypophysial fibers end in this region (Dawson, 1957). In this region there are also nerve fibers from the general area of the medial fore-brain bundle and fibers from the lateral tuberal area (Green, 1951, 1956; Bargmann, 1954). The fourth division of the hypothalamo-neurohypophysial system is the pars nervosa which in mammals contains most of the nerve fiber terminations of the neurohypophysial tract and most of the stored secretion. It is also the major site of the release of the characteristic hormones which pass from it by way of systemic veins directly into the systemic circulation without contact with the pars anterior or pars distalis.

The early investigators assumed not unnaturally that the pars nervosa was the site of elaboration of the hormones which were secreted from it. It is obvious that there must be something unique about the nerve

fibers or the glial cells, or else some unique structural element must be present to account for the secretory function. Herring (1908) considered that the cells present were ordinary glial cells and did not note any peculiarity of the axons other than that they were of larger caliber than non-medullated fibers elsewhere. He, however, did discover some peculiar masses of protein without any definite structure. These bodies were only found in well fixed material and although they did not look to be likely sites for the formation of hormones attention was focused on them by the fact that they were peculiar to this gland.

Buey (1930) found that these Herring bodies were in fact large end bulbs terminating some of the fibers of the neurohypophysial tract. In these end bulbs the fibers were wound about like a ball of twine.

Bodian (1951) confirmed this explanation of Herring bodies and considered that they are terminal malformations, negligible in number compared with normal endings.

Buey (1930) and Weaver and Buey (1940) claimed that the neurohypophysis contained cells which were peculiar in their morphology and staining reactions and were found nowhere else in the nervous system. For these cells the term "pituicyte" was proposed. For a time the pituicytes contended with the Herring bodies and the nerve fibers for the responsibility for the production of the neurohypophysial hormones. As objects to be studied they were certainly more promising in appearance than the nerve fibers, but it cannot be said that the studies of pituicytes have contributed to the elucidation of either neurohypophysial or pituicyte function. The status of the pituicyte as a cell peculiar to the neurohypophysis is at the present time doubtful. Some investigators (Romeis, 1940; Sloper, 1957) have stressed the great diversity of cell types which can be found in the neurohypophysis, but this does not dispose of the pituicyte of Buey. Leveque and Scharrer (1953) considered the existence of a cell specific to the neurohypophysis unproven.

Hild (1956, in discussion) considered that there are no consistent morphologic differences between the glia of the neurohy-

pophysis and astrocytic glia in any other parts of the central nervous system. Certainly the pituicytes do not show any of the features of secreting cells. Recent developments have made it clear that pituicytes are in no way responsible for the production or storage of neurohypophysial secretion and any role that may be ascribed to them in facilitating the release of the hormones into the circulation is purely speculative. It seems unnecessary to assume that their function is different from that of similar glial cells elsewhere.

The hormone activity of the neurohypophysis is accounted for by two octapeptides, oxytocin and vasopressin. Both hormones contain cystine. There is evidence that in the glands they are combined with a specific protein referred to as the van Dyke protein (van Dyke, Chow, Greep and Rothen, 1942). This protein has a molecular weight of approximately 30,000 and a strikingly high content of cystine (approximately 16.0 per cent; the cystine content of insulin is 12.0 per cent).

The morphologic studies of the pars nervosa which followed Buey's designation of pituicytes as specific cells peculiar to the neurohypophysis did not contribute to the elucidation of neurohypophysial function. The true explanation of the function of the neurohypophysis resulted from studies on neurosecretion which were proceeding contemporaneously with the pituicyte investigations but were not, before 1949, considered to be related directly to neurohypophysial secretion.

"Neurosecretion" is a general term referring to the presence within certain neurons of accumulations of products, usually proteins, which are not common to the majority of neurones. The first description of 8 secretion-containing nerve cells was that by Speidel (1919) who described such cells in the spinal cord of the skate. The further development of the subject is amply reviewed by Scharrer and Scharrer (1940, 1945, 1954). Neurosecretory accumulations in the hypothalamus were first described in the bony fish (*Phoxinus lacustris* L.), and further papers by the Scharrers extended their occurrence to bony fishes generally, amphibians, reptiles, mammals, and man.

The term "neurosecretion" was first applied by Scharrer in vertebrates, but it is a general term including a wide variety of secretory phenomena in vertebrate and invertebrate neurones. With the investigations on neurosecretory material in invertebrates we are not here concerned, and further discussion will be limited to the neurosecretory material of certain neurones of the vertebrate hypothalamus.

Neurosecretion was first investigated by non-specific methods of staining, and the evidence for the presence of a secretory product in neurones was the accumulation of protein material in large droplets and vesicles often so large as to cause distortion of the cell within which they were enclosed. Investigations by Scharrer and Scharrer (1940), disclosed a wide occurrence of such gross accumulations of an unusual material in neurones of the preoptic or supraoptic and paraventricular nuclei of many vertebrates, but the absence of any known function for this material was a retarding factor in the development of the subject. Moreover, many species did not appear to have these neurosecretory droplets and in species where they were found they were often not observed in young animals but only in those of older ages. These observations seemed to make it unlikely that any essential function was mediated by this material. Palay (1943) was able to trace a transport of neurosecretory material along the axons of the preopticohypophysial tract in fishes, but with the staining methods then in use it could not be shown that this was a general phenomenon in all vertebrates. This position has been entirely changed by the development of more specific methods for staining neurosecretion which permit its identification, even in traces, by staining methods which demonstrate the specific quality of the protein instead of the earlier method of recognition which depended on the physical form assumed by gross collections of the material.

Bargmann (1949) found that Gomori's (1941) method for staining the insulin-containing granules of the  $\beta$ -cells of the pancreatic islets also stained intensely the accumulations of neurosecretory protein in the vertebrate hypothalamus. The intr-

duction of this chrome-alum hematoxylin staining method revolutionized both the technical side of investigations of neurosecretion and the interpretation of its significance. With this method it became clear that the grosser collections of neurosecretion detected by earlier methods, which occur only in an erratic fashion, constituted but a small part of the hypothalamic neurosecretion which is found in neurones of every vertebrate hypothalamus (Bargmann and Hild 1949; Hild, 1950; 1951a, b; Bargmann, Hild, Ortman and Schiebeler, 1950). The neurosecretory material could be seen throughout the course of the supraoptic and paraventriculo-hypophyseal tracts and their continuations in the neural eminence and stalk into the pars nervosa (Fig. 3.33). The greater part of the stainable neuro-

secretion in mammals is found in the nerve fiber terminals in the pars nervosa; the amount in other parts of the hypothalamo-neurohypophyseal system in some species and especially in young animals may be insignificant by comparison. The distribution corresponds to that of the neurohypophyseal hormones.

In addition to demonstrating the exact distribution of neurosecretion, specific staining made it possible to demonstrate that the material formed in the perikaryon is transported, probably by axoplasmic flow, towards the pars nervosa. After stalk section the stainable neurosecretion accumulates in the proximal stump of the transected axons (Hild, 1951b; Hild and Zetler, 1953; Scharrer and Scharrer, 1954).

Depletion of stainable neurosecretion in the pars nervosa occurs in animals subjected to dehydration (Hild and Zetler, 1953; Leveque and Scharrer, 1953). The loss of stainable material is almost complete in animals subjected to prolonged water deprivation (Fig. 3.34) and parallels the loss of hormone content. It is clear that dehydration is a powerful stimulus to the release of stainable neurosecretion from the pars nervosa and that the material released is either itself hormonally active or is accompanied by the hormones. Moreover, prolonged dehydration causes a depletion of both stainable neurosecretion and of hormone activity in the neurones and axons of the supraoptic and paraventricular nuclei in the hypothalamus. This shows that the hormone activity accompanies the stainable neurosecretion in its passage along the axons, the transport of both being accelerated by the stimulus of dehydration.

From these observations it is inferred that the neurohypophyseal hormones are produced in the perikarya of the neurones of the supraoptic and paraventricular nuclei and are transported along the axons to the fiber terminals from which they are released to be carried away by the adjacent blood vessels. In their formation, transport, and release the hormones are accompanied by or form part of a specific protein, the stainable neurosecretory substance. Observations of the type presented above have been repeated in a number of different spe-

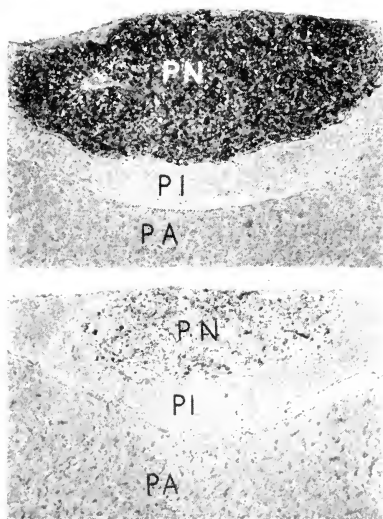

Fig. 3.33 (*upper*). Coronal section of the hypophysis of a normal rat stained with dilute aldehyde-fuchsin (AF) after permanganate oxidation. The pars nervosa contains a large amount of darkly stained neurosecretion. P.N., pars nervosa; P.I., pars intermedia; P.A., pars anterior.  $\text{KMnO}_4$ , AF,  $\times 50$ .

Fig. 3.34 (*lower*). Coronal section of the hypophysis of a rat which was deprived of drinking water for 5 days. An extreme reduction in the content of neurosecretion is apparent in comparison with Figure 3.33. Key to lettering as in Figure 3.33.  $\text{KMnO}_4$ , AF,  $\times 50$ .

cies of vertebrates with results which are always concordant with this concept of the function of hypothalamic neurosecretion. The subject has been reviewed by Bargmann (1954), Scharrer and Scharrer (1954), Palay (1953), Hild (1956), and Sloper (1957). It is now generally accepted that the neurohypophyseal hormones have their origin in the neurosecretory cells of the hypothalamus.

#### B. THE CHEMICAL NATURE OF THE STAINABLE NEUROSECRETORY MATERIAL

Specific histochemical tests indicate that the neurosecretion in the hypothalamus and neurohypophysis is a protein with a high cystine content (Barnett, 1954; Adams and Sloper, 1955). The test used by Adams and Sloper, performic acid oxidation followed by Alcian blue, depends on the oxidation of the sulfur groups of cystine to sulfonic acid groups by performic acid and subsequent binding of the basic dye Alcian blue by the strong acid groups so formed. Dawson's (1953) method depends on the same principles but involves the use of permanganate for the oxidation and aldehyde-fuchsin as a basic dye. It is probable that Gomori's (1941) chrome alum-hematoxylin method also demonstrates sulfonic acid groups formed by permanganate oxidation of cystine, because it as well as Dawson's method stains the insulin-containing granules of pancreatic islet  $\beta$ -cells. There is little doubt that the secretion is a complex of the normally active octapeptides with the van Dyke protein which is demonstrated by these staining methods (Smith, 1951; Sloper, 1957). The amount of material stained is much greater than the content of specific octapeptides and corresponds with estimates of the amount of van Dyke protein present (Albers and Brightman, 1959). The stainable material is not a glyco-lipo-protein complex as suggested by Schiebler (1952) because tests for lipid and carbohydrate are weak, variable in different species, and often negative (Sloper, 1955; Howe and Pearse, 1956).

It is often stated that the stainable component of neurosecretion is an inert carrier substance which can be totally extracted from the tissue by organic solvents leaving

the hormone activity behind. This is not correct. As Sloper (1955) demonstrated, neither the stainable material nor the hormone activity can be extracted by organic solvents, but both remain water soluble after treatment with organic solvents and neither can be demonstrated by staining unless a chemical fixation is used before exposure of the tissue to water. It would appear that about 10 per cent of the cystine content of the van Dyke protein octapeptide complex is in the octapeptide component and that the octapeptides, if they are retained by fixation, contribute to depth of staining of the neurosecretory material by the staining methods now in use.

#### C. THE PHYSICAL FORM OF NEUROSECRETION IN THE NEUROHYPOPHYSIS: THE SECRETORY GRANULE

Electron microscopy is required to reveal the form in which neurosecretion occurs in the mammalian neurohypophysis. Electron microscopic studies of the mammalian neurohypophysis have been published by Green and van Breemen (1955), Palay (1955, 1957) and Bargmann and Knoop (1957).

The relationships of the various structures in the felted mass of nerve fibers and cytoplasmic processes of pituitary cells in the pars nervosa are especially difficult to visualize and this difficulty is responsible for some differences in the interpretation of the structure by the different authors. Our primary interest is with the form in which neurosecretory substance occurs. There is general agreement that it is visible in electron micrographs as numerous spherical bodies 100 to 180  $m\mu$  in diameter. These bodies have the typical structure of secretory granules as seen in the exocrine cells of the pancreas or the endocrine cells of the adenohypophysis. A dense limiting membrane is visible enclosing a homogeneous content. Identification of the granules with the stainable neurosecretion follows from the appearance of the Herring bodies. These bodies in the rat appear to be simple dilations of the axones and do not have the end bulb structure described by Buey (1930) and Bodian (1951) for the Herring bodies in other mammals. In these bulbous structures in the rat the secretory granules are

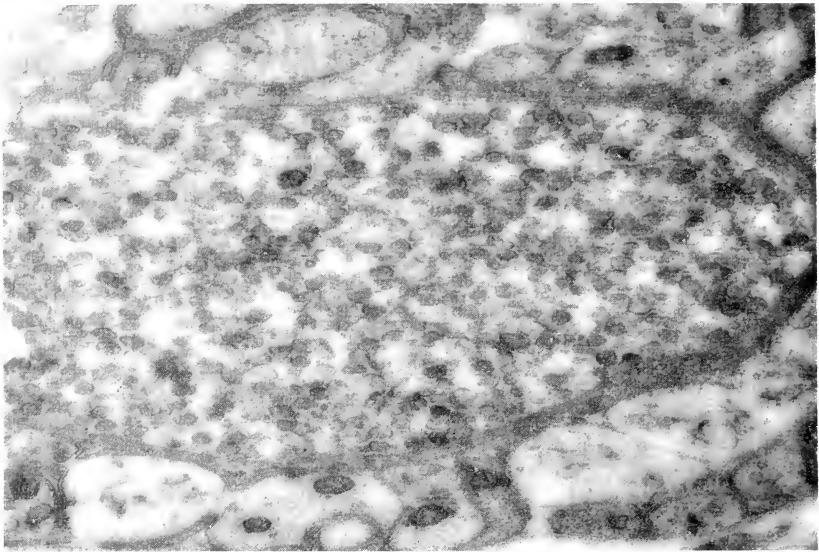

FIG. 3.35. Electronmicrograph of neurohypophysis of rat, nerve terminal containing neurosecretory material inside vesicular membranes, *i.e.*, droplets of neurosecretory substance, or neurosecretory granules. Electronmicrograph by S. L. Palay, National Institutes of Health, Bethesda.  $\times 37,100$ .

so closely packed as to leave little room for any other structure.

Palay finds the neurosecretory granules in the neurones of the supraoptic nucleus and in the axones throughout their course. There is a concentration of the granules in the terminal part of the axons (Fig. 3.35). The terminations are blunt or bulbous and end on a basement membrane separated by connective tissue from the basement membrane and endothelium of the adjacent capillaries. There do not appear to be any secretory granules in the pituicytes. Secretory granules are not found outside the axones in tissue spaces or in the lumen of the capillaries. It appears that only the soluble content of the granule is liberated during secretion; the complete granules are not extruded.

#### D. THE HORMONE CONTENT OF THE NEUROSECRETORY GRANULES

From hypophyseal tissue homogenized in sucrose solution oxytocic and vasopressor activity can be deposited by centrifugation (Pardoe and Weatherall, 1955) and from

this behavior it is inferred that the hormones are contained in the granules and that in sucrose solution the granules are preserved with their hormone content intact. Pardoe and Weatherall obtained evidence that the oxytocin and vasopressor activities were in particles of different size or of different fragility because a partial separation was obtained by differential centrifugation. This behavior of these hormones in tissue suspensions in sucrose solutions is paralleled by that of the gonadotrophic hormones, as found by McShan and Meyer (1952).

The stainable content of the neurosecretory granules is released by agents which destroy the membrane. It is removed in tissue which has been perfused by buffers saturated with ether.

#### E. THE DISTRIBUTION OF OXYTOCIN AND VASOPRESSIN

The ratio of vasopressin to oxytocin varies markedly among different species of mammals and also is variable in different parts of the hypothalamo-neurohypophyseal



system in any one species (Adamson, Engel, van Dyke, Schmidt-Nielsen and Schmidt-Nielsen, 1956). In the camel the ratio vasopressin:oxytocin in the supraoptic nucleus is 2.6, the ratio in the paraventricular nucleus is 0.26. The ratios of vasopressin to oxytocin in the supraoptic and paraventricular nuclei of the dog are approximately 10 times those in the camel.

A simple explanation of these variations would be provided by the hypothesis that the two hormones are formed in different cells. One advantage of such an hypothesis is that it provides the only simple explanation of the ability to secrete the hormones separately (Smith, 1951). The fact that two types of neurosecretory cells have not been demonstrated in the supraoptic and paraventricular nuclei by staining reactions is no objection to this hypothesis; the staining reactions at present used to demonstrate neurosecretion would not be expected to differentiate cells whose secretions are so closely related chemically.

#### F. INFERENCES CONCERNING RATE OF SECRETION FROM CYTOLOGIC AND HISTOCHEMICAL STUDIES

The staining of neurosecretion in sections allows an estimate of the hormone content and a demonstration of changes in hormone content of different parts of the hypothalamo-neurohypophysial system to be made, but does not demonstrate the rate of formation or release of neurosecretion. The demonstration by Sloper (1957) that  $S^{35}$ -labeled cystine is incorporated into the neurosecretion suggests a method by which the rate of turnover as distinct from the content may be investigated.

The neurosecretion must be formed by the ribonucleic acid-containing material in the perikaryon which in nerve cells is called Nissl substance. The marked accumulation of neurosecretion in some neurones of old animals of certain species which eventually fills the axon, the dendrites, and a large part of the perikaryon, is apparently the result of an aging process which makes it difficult for such cells to release their secretion. That there is a stagnation in such cells is indicated by the fact that the amount of Nissl substance in such cells is much reduced (Hild, 1956).

It is the cells which do not show such marked accumulations of neurosecretion, except at their axone terminals, and have large amounts of Nissl substance in their perikarya, that are presumably responsible for most of the secretory function of the system. There does not seem, therefore, to be any relation between the accumulations of neurosecretion in the cells of the hypothalamus and the secretory function; in particular there is no reason to think that the accumulation of neurosecretion in the hypothalamus is related more directly to alterations in adeno-hypophyseal than to a disturbance of neurohypophysial function.

Pepler and Pearce (1957) observed hypertrophy of the cells of the supraoptic and paraventricular nuclei in rats given 2.5 per cent NaCl in the drinking water and also in lactating rats. In both groups there was an increase in the amount of specific acetylcholine esterase in the hypertrophied cells. From these observations it may be inferred that the reduction both of hormone content and stainable neurosecretion observed by Rennels (1958) in the neurohypophyses of lactating rats was accompanied by an increased production of neurosecretion and was therefore the result of an increased rate of discharge of this material. It would appear that the demonstration of the content of specific enzymes by methods which are capable of giving a cytologic localization may prove to be a valuable method of estimating the rate of secretion by endocrine cells. Such methods are badly needed to complement the information obtained from the staining of specific granules which indicates only the hormone content.

#### XVI. References

- ADAMS, C. W. M., AND SLOPER, J. C. 1955. The hypothalamic elaboration of posterior pituitary principles in man, the rat and dog: histochemical evidence derived from a performic acid-Alcian blue reaction for cystine. *J. Endocrinol.*, **13**, 221-228.
- ADAMS, C. W. M., AND SWETTENHAM, K. V. 1958. The histochemical identification of two types of basophil cell in the normal human adenohypophysis. *J. Path. & Bact.*, **75**, 95-103.
- ADAMSON, K., ENGEL, S. L., VAN DYKE, H. B., SCHMIDT-NIELSEN, B., AND SCHMIDT-NIELSEN, K. 1956. The distribution of oxytocin and vasopressin (antidiuretic hormone) in the neurohypophysis of the camel. *Endocrinology*, **58**, 272-278.

- ALBERS, R. W., AND BRIGHTMAN, M. W. 1959. A major component of neurohypophysial tissue associated with antidiuretic activity. *J. Neurochem.*, **3**, 269-276.
- ALLARA, E. 1953. Ricerche sui processi secretori nelle ghiandole endocrine. IV. Modificazioni indotte dalla bassa temperatura sulla struttura dell'ipofisi di *Mus rattus albinus*. *Boll. Soc. ital. biol. sper.*, **28**, 1989-1991.
- ALLEN, B. M. 1930. Source of the pigmentary hormone of amphibian hypophysis. *Proc. Soc. Exper. Biol. & Med.*, **27**, 504-505.
- APLINGTON, H. W., JR. 1942. Correlative cyclical changes in the hypophysis and gonads of *Necturus maculosus rafinesque*. *Am. J. Anat.*, **70**, 201-249.
- ASTWOOD, E. B., RABEN, M. S., AND PAYNE, R. W. 1952. *Recent Progr. Hormone Res.*, **7**, 1-57.
- AZIMOV, G. I., AND ALTMAN, A. D. 1938. Various parts of the anterior lobe of the pituitary body and the physiology of lactation. *Compt. rend. Acad. sc. U.S.S.R.*, **20**, 621-625.
- BAILEY, P., AND DAVIDOFF, L. M. 1925. Concerning the microscopic structure of the hypophysis cerebri in acromegaly. *Am. J. Path.*, **1**, 185-207.
- BAKER, B. L., AND EVERETT, N. B. 1947. The effect of diethylstilbestrol on the anterior hypophysis of thyroidectomized rats. *Endocrinology*, **41**, 144-157.
- BARGMANN, W. 1949. Über die neurosekretorische Verknüpfung von Hypothalamus und Neurohypophyse. *Ztschr. Zellforsch.*, **34**, 610-634.
- BARGMANN, W. 1954. *Das Zwischenhirnhypophysensystem*. Berlin: Springer-Verlag.
- BARGMANN, W., AND HILD, W. 1949. Über die Morphologie der neurosekretorischen Verknüpfung von Hypothalamus und Neurohypophyse. *Acta Anat.*, **8**, 264-280.
- BARGMANN, W., HILD, W., ORTMAN, R., AND SCHIEBLER, T. H. 1950. Morphologische und experimentelle Untersuchungen über das hypothalamischhypophysäre System. *Acta neuroveg.*, **1**, 233-275.
- BARGMANN, W., AND KNOOP, A. 1957. Elektronenmikroskopische Beobachtungen an der Neurohypophyse. *Ztschr. Zellforsch.*, **46**, 242-251.
- BARRINGTON, E. J. W., AND MATTY, A. J. 1955. The identification of thyrotrophin-secreting cells in the pituitary gland of the minnow (*Phoxinus phoxinus*). *Quart. J. Microscop. Sc.*, **96**, 193-201.
- BARNETT, R. J. 1953. The histochemical distribution of protein-bound sulfhydryl groups. *J. Nat. Cancer Inst.*, **53**, 905-926.
- BARNETT, R. J. 1954. Histochemical demonstration of disulfide groups in the neurohypophysis under normal and experimental conditions. *Endocrinology*, **55**, 484-501.
- BARNETT, R. J., AND GREIF, R. O. 1951. The pituitary gonadotropic activity of stalk-sectioned male rats. *Endocrinology*, **49**, 337-348.
- BARNETT, R. J., LADMAN, E. J., McALLISTER, N. J., AND SUPERSTEIN, E. R. 1956. The localization of glycoprotein hormones in the anterior pituitary glands of rats investigated by differential protein solubilities, histological stains and bio-assays. *Endocrinology*, **59**, 398-418.
- BARNETT, R. J., AND SELIGMAN, A. M. 1954. Histochemical demonstration of sulfhydryl and disulfide groups of protein. *J. Nat. Cancer Inst.*, **54**, 769-803.
- BERBLINGER, W. 1932. Pathologie und pathologische Morphologie der Hypophyse des Menschen. In *Handbuch der inneren Sekretion*, M. Hirsch, Ed. Vol I, pp. 910-1097.
- BERBLINGER, W., AND BURGGRAF, A. L. 1935. Neue Färbemethode zur Darstellung der Gewebestandteile der Hypophyse des Menschen. *Endokrinologie*, **15**, 381-388.
- BODIAN, D. 1951. Nerve endings, neurosecretory substance, and lobular organization of the neurohypophysis. *Bull. Johns Hopkins Hosp.*, **89**, 354-376.
- BRADBURY, J. T. 1947. Ovarian influence on the response of the anterior pituitary to estrogens. *Endocrinology*, **41**, 501-513.
- BROKAW, R., BRISENO-CASTREJON, B., AND FINERTY, J. C. 1950. Quantitative studies of cell types in the rat hypophysis following prolonged periods of unilateral adrenalectomy. *Texas Rep. Biol. & Med.*, **8**, 312-319.
- BROLIN, S. E. 1945. A study of the structural and hormonal reactions of the pituitary body of rats exposed to cold. *Acta Anat., Suppl.*, **3**, 1-165.
- BROOKS, C. McC. 1938. A study of the mechanisms whereby coitus excites the ovulation-producing activity of the rabbit's pituitary. *Am. J. Physiol.*, **121**, 157-177.
- BROWN, L. H. V., AND HESS, M. 1957. Separation of hormone activities in the anterior pituitary by ultracentrifugation. *Am. J. Physiol.*, **188**, 25-29.
- BROWN, L. T., AND KNIGGE, K. M. 1958. Cytology of the pars distalis in the pituitary gland of the chicken. *Anat. Rec.*, **130**, 395-396.
- BUCEY, P. C. 1930. The pars nervosa of the bovine hypophysis. *J. Comp. Neurol.*, **50**, 505-519.
- BURCH, A. B. 1946. An experimental study of the histological and functional differentiation of the epithelial hypophysis in *Hyla regilla*. *Univ. California Publ. Zool.*, **51**, 185-213.
- BURT, A. S., AND VELARDO, J. T. 1954. Cytology of the human adenohypophysis as related to bioassays for tropic hormones. *J. Clin. Endocrinol.*, **14**, 979-996.
- CATCHPOLE, H. R. 1947. Cellular distribution of glycoprotein in the anterior pituitary gland. In *Communications of 17th International Physiological Congress*, p. 65. London: Oxford University Press.
- CATCHPOLE, H. R. 1949. Distribution of glycoprotein hormones in the anterior pituitary gland of the rat. *J. Endocrinol.*, **6**, 218-225.
- CHADWICK, C. S. 1936. Cyclic morphologic variations in the anterior hypophysis of the guinea pig. *Am. J. Anat.*, **60**, 129-147.

- CHITI, E., AND ZINOLLI, J. 1952. Relationships between pituitaries and adrenals. Arch. Marchiano Pat. Clin., **7**, 41-57.
- CIESLAK, E. S. 1945. Relations between the reproductive cycle and the pituitary gland in the snake (*Thamnophis radix*). Physiol. Zool., **18**, 299-329.
- CLEVELAND, R., AND WOLFE, J. M. 1933. Cyclic histological changes and variations in the anterior hypophysis of the sow (*Sus scrofa*). Am. J. Anat., **53**, 191-220.
- COLOMBO, E. 1948. The effect of bilateral adrenalectomy on the adenohypophysis. Prensa méd. argent., **35**, 1951-1955.
- COLOMBO, E. 1949. Cellular changes of the anterior pituitary gland after unilateral adrenalectomy. Prensa méd. argent., **36**, 1496-1498.
- COPELAND, D. E. 1943. Cytology of the pituitary gland in developing and adult *Triturus viridescens*. J. Morphol., **72**, 379-409.
- CORDIER, R. 1953. L'hypophyse de *Xenopus*. Ann. Soc. Roy. Zool. Belg., **84**, 5-16.
- CROOKE, A. C. 1935. A change in the basophil cells of the pituitary gland common to conditions which exhibit the syndrome attributed to basophil adenoma. J. Path. & Bact., **41**, 339-349.
- CROOKE, A. C., AND RUSSELL, D. S. 1935. Pituitary gland in Addison's disease. J. Path. & Bact., **40**, 255-283.
- CROSSMAN, G. C. 1937. A modification of Mallory's connective tissue stain with a discussion of the principles involved. Anat. Rec., **69**, 33-38.
- CUSHING, H., AND DAVIDOFF, L. M. 1927. The pathological findings in four autopsied cases of acromegaly with a discussion of their significance. Rockefeller Inst. Med. Res. Monogr., **22**, 1-131.
- DALTON, A. J., AND FELIX, M. D. 1953. Studies on the Golgi substance of the epithelial cells of the epididymis and duodenum of the mouse. Am. J. Anat., **92**, 277-305.
- DALTON, A. J., AND FELIX, M. D. 1954. Cytologic and cytochemical characteristics of the Golgi substance of epithelial cells of the epididymis—*in situ*, in homogenates, and after isolation. Am. J. Anat., **94**, 171-208.
- DALTON, A. J., AND FELIX, M. D. 1956. A comparative study of the Golgi complex. J. Biophys. Biochem. Cytol., Suppl., **2**, 79-83.
- D'ANGELO, S. A. 1955. Thyrotrophic hormone production and aldehyde-fuchsin staining basophils in the rodent adenohypophysis. Anat. Rec., **121**, 282.
- DAWSON, A. B. 1938. The epithelial components of the pituitary gland of the opossum. Anat. Rec., **72**, 181-193.
- DAWSON, A. B. 1939. Differential staining of the anterior pituitary gland of the cat. Stain Technol., **14**, 133-138.
- DAWSON, A. B. 1946. Some evidences of specific secretory activity of the anterior pituitary gland of the cat. Am. J. Anat., **78**, 347-410.
- DAWSON, A. B. 1948. The relationship of pars tuberalis to pars distalis in the hypophysis of the rhesus monkey. Anat. Rec., **102**, 103-122.
- DAWSON, A. B. 1953. Evidence for the termination of neurosecretory fibers within the pars intermedia of the hypophysis of the frog, *Rana pipiens*. Anat. Rec., **115**, 63-69.
- DAWSON, A. B. 1954a. Differential staining of two types of acidophile in the anterior pituitary gland of the rat. Anat. Rec., **120**, 810.
- DAWSON, A. B. 1954b. The regional localization of five distinct morphological types of cells in the anterior pituitary gland of the rhesus monkey. Anat. Rec., **120**, 810.
- DAWSON, A. B. 1957. Morphological evidence of a possible functional interrelationship between the median eminence and the pars distalis of the Anuran hypophysis. Anat. Rec., **128**: 77-89.
- DAWSON, A. B., AND FRIEDGOOD, H. B. 1937. The occurrence and distribution of a third type of granular cell in the anterior pituitary of the cat. Anat. Rec., Suppl. I, **70**, 129.
- DAWSON, A. B., AND FRIEDGOOD, H. B. 1938a. Differentiation of two classes of acidophiles in the anterior pituitary of the female rabbit and cat. Stain Technol., **13**, 17-21.
- DAWSON, A. B., AND FRIEDGOOD, H. B. 1938b. The occurrence of a second type of acidophile cell in the anterior pituitary of the female cat and its relation to sexual activity. Anat. Rec., Suppl., **70**, 21.
- DELAUNDER, A. M., TARR, L., AND GELLING, E. M. K. 1934. The distribution in the chicken's hypophysis of the so-called posterior lobe principles. J. Pharmacol. & Exper. Therap., **51**, 142-143.
- DEMPSY, E. W., AND WISLOCKI, G. B. 1945. Histochemical reactions associated with basophilia and acidophilia in the placenta and pituitary gland. Am. J. Anat., **76**, 277-301.
- DESCLAUX, P., SOULAMIR, A., AND CHANEAC, H. 1953. Origine de l'hormone corticotrope à partir des cellules eosinophiles de l'hypophyse. Compt. rend. Soc. biol., **147**, 44-45.
- DREYFUS, G., AND ZARA, M. 1951. La cellule de Crooke; cellule réactionnelle au cours de l'hypertrophiisme. Bull. Soc. Med. Hôp. Paris, **67**, 15-16.
- EAKIN, R. M., AND BUSH, F. E. 1957. Development of the amphibian pituitary with special reference to the neural lobe. Anat. Rec., **129**, 279-295.
- EDMONDS, A. W. B., McKEOWN, K. C., AND COLEMAN, P. N. 1958. A case of Cushing's syndrome with pigmentation and severe hypokalaemic alkalosis. J. Clin. Path., **11**, 237-243.
- ELDER, W. H., AND FINERTY, J. C. 1943. Gonadotrophic activity of the pituitary gland in relation to the seasonal sexual cycle of the cottontail rabbit (*Sylvilagus floridanus mearnsi*). Anat. Rec., **85**, 1-16.
- ELFTMAN, H. 1956. Response of the anterior : -

- tivity to dichromate oxidation. *J. Histochem.*, **4**, 110-111.
- ERDHEIM, J. 1926. Pathologie der Hypophysengeschwülste. *Ergeb. Path.*, **21**, 482-561.
- ERDHEIM, J., AND STUMME, E. 1909. Über die Schwangerschaftsveränderung bei der hypophys. *Beitr. path. Anat.*, **46**, 1-17.
- ETKIN, W. 1941. On the control of growth and activity of the pars intermedia of the pituitary by the hypothalamus in the tadpole. *J. Exper. Zool.*, **86**, 113-139.
- ETKIN, W. 1958. Independent differentiation in components of the pituitary complex in the wood frog. *Proc. Soc. Exper. Biol. & Med.*, **97**, 388-393.
- EVANS, H. M., AND SIMPSON, M. E. 1929. The effect of pregnancy on the anterior hypophysis of the rat and cow as judged by the capacity of implants to produce precocious maturity. *Am. J. Physiol.*, **89**, 379-380.
- EVERETT, N. B., AND BAKER, B. L. 1945. The distribution of cell types in anterior hypophysis during late pregnancy and lactation. *Endocrinology*, **37**, 83-88.
- EZHIN, C., SWANSON, H. E., HUMPHREY, J. G., DAWSON, J. W., AND WILSON, W. 1958. The delta cell of the human adenohypophysis: its response to acute and chronic illness. *J. Clin. Endocrinol.*, **18**, 971-936.
- FARQUHAR, M. G. 1956. Preparation of ultrathin tissue sections for electron microscopy: review and compilation of procedures. *Lab. Invest.*, **5**, 317-337.
- FARQUHAR, M. G. 1957. "Corticotrophs" of the rat adenohypophysis as revealed by electron microscopy. *Anat. Rec.*, **127**, 291.
- FARQUHAR, M. G., AND RINEHART, J. F. 1954a. Electron microscopic studies of the anterior pituitary gland of castrate rats. *Endocrinology*, **54**, 516-541.
- FARQUHAR, M. G., AND RINEHART, J. F. 1954b. Cytologic alterations in the anterior pituitary gland following thyroidectomy: an electron microscope study. *Endocrinology*, **55**, 857-876.
- FARQUHAR, M. G., AND RINEHART, J. F. 1955. Further evidence for the existence of two types of gonadotrophs in the anterior pituitary of the rat. *Anat. Rec.*, **121**, 394.
- FARQUHAR, M. G., AND WELLINGS, S. R. 1957. Electron microscopic evidence suggesting secretory granule formation within the Golgi apparatus. *J. Biophys. Biochem. Cytol.*, **3**, 319-322.
- FINERTY, J. C., AND BINHAMMER, R. 1952. The effects of severe burns on pituitary cytology and adrenocorticotrophic function. *Anat. Rec.*, **112**, 329.
- FINERTY, J. C., HESS, M., AND BINHAMMER, R. 1952. Pituitary cytological manifestations of heightened adrenocorticotrophic activity. *Anat. Rec.*, **114**, 115-125.
- FISHER, C. 1937. The site of formation of the posterior lobe hormones. *Endocrinology*, **21**, 19-29.
- FLOBERG, S. 1919. Changes in the human hypophysis in connection with pregnancy. *Acta. Anat.*, **8**, 329-346.
- FOLLEY, S. J. 1952. Some aspects of the physiology of the anterior pituitary lactogenic hormone. *Ciba Foundation Colloquia Endocrinol.*, **4**, 381-401.
- FOLLEY, S. J., AND YOUNG, F. G. 1938. The effect of anterior pituitary extracts on established lactation in the cow. *Proc. Roy. Soc., London, ser. B*, **126**, 45.
- FOSTER, C. L. 1947. Some observations upon the Golgi elements of the anterior pituitary cells of normal and stilbestrol-treated male rats, using the Sudan black technique. *Quart. J. Microscop. Sc.*, **88**/4, 409-417.
- FOSTER, C. L., AND WILSON, R. R. 1951. Gram-positive cells of the human anterior pituitary. *Nature, London*, **167**, 528-529.
- FRIEDGOOD, H. B., AND DAWSON, A. B. 1940. Physiological significance and morphology of the carmine cell in the rat's anterior pituitary. *Endocrinology*, **26**, 1022-1031.
- FRIEDMAN, M. H., AND HALL, S. R. 1941. The site of elaboration of the pituitary gonadotrophic hormone and of prolactin. *Endocrinology*, **29**, 179-186.
- GATENBY, J. B., AND LUFTY, R. G. 1956. The Golgi apparatus and the electron microscope. *Nature, London*, **177**, 1027-1029.
- GABE, M. 1953. Sur quelques applications de la coloration par la fuchsine-paraldéhyde. *Bull. Microscop. Appl., Paris*, **3**, 153-162.
- GEILING, E. M. K. 1935. The hypophysis of the finback (*Balaenoptera physalis*) and the sperm (*Physceter megaloccephalus*) whale. *Bull. Johns Hopkins Hosp.*, **57**, 123-142.
- GESCHWIND, I. I., HESS, G. P., CONDLIFFE, P. G., EVANS, H. M., AND SIMPSON, M. E. 1950. Preparation of nonprotein fractions possessing adrenocorticotrophic activity from fresh sheep pituitary glands. *Science*, **112**, 436-437.
- GESCHWIND, I. I., AND LI, C. H. 1952. Interaction of growth hormone with thyroxine and other hormones, as measured by the tibia test. *J. Clin. Endocrinol.*, **12**, 937.
- GILMORE, L. O., PETERSEN, W. E., AND RASMUSSEN, A. T. 1941. Some morphological and functional relationships of the bovine hypophysis. *Univ. Minnesota Agric. Exper. Sta., Tech. Bull.* **145**.
- GIROUD, A., AND MARTINET, M. 1948. Localisations de certaines fonctions dans le lobe antérieur de l'hypophyse. *Ann. endocrinol.*, **9**, 343-349.
- GOLDBERG, R. C., AND CHAIKOFF, I. L. 1952a. On the occurrence of six cell types in the dog anterior pituitary. *Anat. Rec.*, **112**, 265-274.
- GOLDBERG, R. C., AND CHAIKOFF, I. L. 1952b. Myxedema in the radiothyroidectomized dog. *Endocrinology*, **50**, 115-123.
- GOLDEN, A., BONDY, P. K., AND SHELTON, W. H. 1950. Pituitary basophilic hyperplasia and Crooke's hyaline changes in man after ACTH therapy. *Proc. Soc. Exper. Biol. & Med.*, **74**, 155-158.
- GOMORI, G. 1911. Observations with differential

- stains on human islets of Langerhans. *Am. J. Pathol.*, **17**, 395-406.
- GOMORI, G. 1950. Aldehyde-fuchsin: a new stain for elastic tissue. *Am. J. Clin. Pathol.*, **20**, 665-666.
- GREEN, J. D. 1951. Comparative anatomy of hypophysis with special reference to its blood supply and innervation. *Am. J. Anat.*, **88**, 225-311.
- GREEN, J. D. 1956. Neural pathways to the hypophysis in *Hypothalamic-hypophysial Interrelationships*, W. S. Fields, Ed., pp. 3-16. Springfield, Ill.: Charles C Thomas.
- GREEN, J. D., AND VAN BREEMEN, V. L. 1955. Electron microscopy of the pituitary and observations on neurosecretion. *Am. J. Anat.*, **97**, 177-227.
- GRIEP, R. O., AND CHESTER JONES, I. 1950. Steroid control of pituitary function. *Recent Progr. Hormone Res.*, **5**, 197-261.
- GUYER, M. F., AND CLAUS, P. E. 1957. Vacuolation of the anterior pituitary gland following castration, implantation of cancer tissue, and thyroidectomy. *Anat. Rec.*, **67**, 145-155.
- GRIESBAUM, W. E., HORNABROOK, R. W., AND PURVES, H. D. 1956. Changes in the rat pituitary produced by exposure to cold. In *Communications of XXth International Physiological Congress*, p. 370. London: Oxford University Press.
- HALMI, N. S. 1950. Two types of basophils in the anterior pituitary of the rat and their respective cytophysiological significance. *Endocrinology*, **47**, 289-299.
- HALMI, N. S. 1951a. Differentiation of two types of basophils in the adenohypophysis of the rat and the mouse. *Stain Technol.*, **27**, 61-64.
- HALMI, N. S. 1951b. Further observations on two types of basophil cells in the anterior pituitary. *Anat. Rec.*, **109**, 300.
- HALMI, N. S. 1952a. Two types of basophils in the rat pituitary: "thyrotrophs" and gonadotrophs" vs. beta and delta cells. *Endocrinology*, **50**, 140-142.
- HALMI, N. S. 1952b. The effects of graded doses of thyroxine on the anterior pituitary of hypothyroid male albino rats. *Anat. Rec.*, **112**, 17-36.
- HALMI, N. S., AND BODANOYE, E. M. 1951. Effect of thyroidectomy on ACTH content of rat adenohypophysis. *Proc. Soc. Exper. Biol. & Med.*, **77**, 518-520.
- HALMI, N. S., AND DAVIES, J. 1953. Comparison of aldehyde-fuchsin staining, metachromasia and periodic acid-Schiff reactivity of various tissues. *J. Histochem.*, **1**, 447-459.
- HARTMANN, J. F. 1944. Seasonal cytological changes in the anterior hypophysis of the garter snake. *Am. J. Anat.*, **75**, 121-149.
- HARTMANN, J. F., FAIR, W. R., AND WOLFE, J. M. 1946. A cytological study of the anterior hypophysis of the dog with particular reference to the presence of a fourth cell type. *Anat. Rec.*, **95**, 11-27.
- HEDINGER, C. E., AND FARQUHAR, M. G. 1957. Elektronenmikroskopische Untersuchungen von zwei Typen acidophilen Hypophysenvorderlappenzellen bei der Ratte. *Schweiz. Ztschr. allg. Pathol.*, **20**, 766-768.
- HELLWEG, G. 1951. Über die Silberimprägnierbaren Zellen der menschlichen Hypophyse. *Ztschr. Zellforsch.*, **36**, 349-360.
- HERLANT, M. 1936a. Influence de l'urémie expérimentale sur l'hypophyse du rat. *Compt. rend. Soc. biol.*, **123**, 538-540.
- HERLANT, M. 1936b. Influence de la basophilie expérimentale sur le pouvoir gonadotrope de l'hypophyse du rat. *Compt. rend. Soc. biol.*, **123**, 1267-1270.
- HERLANT, M. 1942. Déterminisme de la basophilie des cellules cyanophiles du lobe antérieur de l'hypophyse. Extrait du Bulletin de l'Académie royale de Belgique (Classe des Sciences) Séance de 4 juillet 1942, Nos. 7-9.
- HERLANT, M. 1943. Recherches sur la localisation histologique des hormones gonadotropes femelle au niveau de l'hypophyse antérieure. *Arch. Biol.*, **54**, 225-357.
- HERLANT, M. 1949. Study of the pituitary body with the periodic acid-Schiff reaction. *Nature*, London, **164**, 703-704.
- HERLANT, M. 1951. Étude des cellules basophiles de l'hypophyse par la méthode histophotométrique. *Ann. Endocrinol.*, **12**, 80-88.
- HERLANT, M. 1952a. Séparation des activités du lobe antérieur de l'hypophyse par la méthode des centrifugations différentielles. *Ann. endocrinol.*, **13**, 611-623.
- HERLANT, M. 1952b. Les granulations acidophiles de l'hypophyse et leur signification physiologique. *Compt. rend. Soc. biol.*, **146**, 1280-1282.
- HERLANT, M. 1953a. La corticotrophine est bien élaborée par les cellules acidophiles de l'hypophyse. *Ann. endocrinol.*, **14**, 64-70.
- HERLANT, M. 1953b. Localisation des hormones gonadotropes au niveau des cellules du lobe antérieur de l'hypophyse. Extrait de la 2<sup>e</sup> Réunion des Endocrinologistes de la Langue française, pp. 81-100. Paris: Masson & Cie.
- HERLANT, M. 1954a. Anatomie et physiologie comparées de l'hypophyse dans la série de vertébrés. *Bull. Soc. Zool. France*, **79**, 256-281.
- HERLANT, M. 1954b. Nouvelles recherches sur les cellules basophiles de l'hypophyse chez l'homme. *Compt. rend. A. Anat.*, **40**, 443-447.
- HERLANT, M. 1955. Mise en évidence de la somatotrophine dans les suspensions de granulations acidophiles de l'hypophyse par son influence sur des cellules  $\alpha$  du pancréas. *Compt. rend. Acad. Sc.*, **240**, 1479-1481.
- HERLANT, M. 1956a. Corrélations hypophysogénitales chez la femelle de la Chauve-Souris, *Myotis myotis* (Borkhausen). *Arch. Biol.*, **67**, 89-180.
- HERLANT, M. 1956b. Les cellules basophiles du lobe antérieur de l'hypophyse chez l'homme. *Arch. Biol.*, **67**, 539-553.
- HERLANT, M. 1958. La dualité des cellules gonadotropes au niveau du lobe antérieur de l'hypophyse. *Bull. Soc. Roy. Belge Gynec. et Obst.*, **28**, 69-81.
- HERLANT, M., AND LISON, L. 1951. Étude des cel-

- ules basophiles de l'hypophyse par la méthode histophotométrique. *Ann. endocrinol.*, **12**, 80-88.
- HERLANT, M., AND RACADOT, S. 1957. Le lobe antérieur de l'hypophyse de la chatte au cours de la gestation et de la lactation. *Arch. Biol.*, **58**, 217-248.
- HERRICK, E. H., AND FINERTY, J. C. 1940. The effect of adrenalectomy on the anterior pituitaries of fowls. *Endocrinology*, **27**, 279-282.
- HERRING, P. T. 1908. The histological appearances of the mammalian pituitary body. *Quart. J. Exper. Physiol.*, **1**, 121-159.
- HESS, M., SLADE, I. H., AMMOSS, J. C., AND HENDRIX, V. 1955. Pituitary ACTH content of thyroidectomized-stressed rats. *Anat. Rec.*, **121**, 309.
- HEWER, T. F. 1943. Ateliotic dwarfism with normal sexual function: a result of hypopituitarism. *J. Endocrinol.*, **3**, 397-400.
- HILD, W. 1950. Zur Frage der Neurosekretion im Zwischenhirn der Schleie (*Tinca vulgaris*) und ihrer Beziehung zur Neurohypophyse. *Ztschr. Zellforsch.*, **35**, 33-46.
- HILD, W. 1951a. Vergleichende Untersuchungen über Neurosekretion im Zwischenhirn von Amphibien und Reptilien. *Ztschr. Anat.*, **115**, 459-479.
- HILD, W. 1951b. Das Verhalten des neurosekretorischen Systems nach Hypophysenstieldurchschneidung und die physiologische Bedeutung des Neurosekrets. *Acta neuroveg.*, **3**, 81-91.
- HILD, W. 1956. Neurosecretion in the central nervous system. In *Hypothalamic-hypophysial Interrelationships*, W. S. Fields, Ed., pp. 17-30. Springfield, Ill.: Charles C Thomas.
- HILD, W., AND ZETLER, G. 1953. Experimenteller Beweis für die Entstehung der sog. Hypophysenhinterlappenwirkstoffe in Hypothalamus. *Arch. ges. Physiol.*, **257**, 169-201.
- HILDEBRAND, L. E., RENNELS, E. G., AND FINERTY, J. C. 1957. Gonadotrophic cells of the rat hypophysis and their relation to hormone production. *Ztschr. Zellforsch.*, **46**, 400-411.
- HOHLWEG, W., AND CHAMORRO, A. 1937. Über die luteinisierende Wirkung des Follikelhormons durch Beeinflussung der luteogenen Hypophysenvorderlappensekretion. *Klin. Wchnschr.*, **16**, 196-197.
- HOHLWEG, W., AND JUNKMANN, K. 1933. Über die Beziehungen zwischen Hypophysenvorderlappen und Schilddrüse. *Arch. ges. Physiol.*, **232**, 148-158.
- HOTCHKISS, R. D. 1948. Microchemical reaction resulting in staining of polysaccharide structures in fixed tissue preparations. *Arch. Biochem.*, **16**, 131-141.
- HOUSSAY, B. A. 1952. Structural changes in the anterior pituitary with special reference to the adrenal cortex. *Ciba Foundation Colloquia Endocrinol.*, **4**, 33-35 (in discussion).
- HOWE, A., AND PEARSE, A. G. E. 1956. A histochemical investigation of neurosecretory substance in the rat. *J. Histochem.*, **4**, 561-569.
- HOWATSON, A. F., AND HAM, A. W. 1957. The fine structure of cells. *Canad. J. Biochem. Physiol.*, **35**, 549-564.
- HUBBLE, D. 1949. Cushing's syndrome and thymic carcinoma. *Quart. J. Med.*, **18**, 133-147.
- HUM, R. F., GOLDBERG, R. C., AND CHAIKOFF, I. L. 1951. Effect of excess iodide upon anterior pituitary cytology of the completely thyroidectomized rat and its bearing on the question of extrathyroidal thyroxine synthesis. *Endocrinology*, **49**, 21-24.
- HUNT, T. E. 1949. Mitotic activity in the hypophysis of the rat during pregnancy and lactation. *Anat. Rec.*, **105**, 361-373.
- HURST, V., AND TURNER, C. W. 1942. Lactogenic hormone content of anterior pituitary gland of albino mouse as compared to other species. *Endocrinology*, **31**, 334-339.
- JOST, A., AND DANYSZ, P. 1952. Recherches histochemiques (réaction de MacManus) et expérimentales (decapitation) sur la physiologie de l'hypophyse foetale du lapin. *Compt. rend. Soc. biol.*, **146**, 1062-1066.
- JOST, A., AND TAVERNIER, R. 1956. Application de la méthode à l'acide périodique-Schiff (MacManus) à l'étude de l'hypophyse foetale du rat. *Compt. rend. Acad. Sc.*, **243**, 1353-1356.
- KAHN, K. 1935. Action de l'hyperinsulinisation chronique sur l'histostructure de la pars antérieure de l'hypophyse du cobaye. *Bull. Histol. appl. à Physiol.*, **12**, 300-317.
- KEENE, M. F. L., AND HEWER, E. E. 1924. Glandular activity in the human foetus. *Lancet*, **2**, 111-112.
- KELSEY, F. O., SORENSON, L., HAGEN, A. A., AND CLAUSEN, H. J. 1957. Distribution of oxytocin, vasopressin, and intermediin in the hypophysis of the beaver. *Proc. Soc. Exper. Biol. & Med.*, **95**, 703-704.
- KIRKMAN, H. 1937. A cytological study of the anterior hypophysis of the guinea pig and a statistical analysis of its cell types. *Am. J. Anat.*, **61**, 233-287.
- KNIGGE, K. M. 1955. Cytological changes in the hypophyses of intact and thyroidectomized rats subjected to stress. *Anat. Rec.*, **122**, 295-315.
- KNIGGE, K. M. 1957. Cytology and hormone content of rat pituitary glands following adrenalectomy. *Proc. Soc. Exper. Biol. & Med.*, **94**, 640-643.
- KONEFF, A. A., HOLMES, R. O., AND REESE, J. D. 1941. Prevention of adrenalectomy changes in the anterior pituitary of the rat by sodium chloride administration. *Anat. Rec.*, **79**, 275-289.
- KRAUS, E. J. 1923. Zur Pathologie der basophilen Zellen der Hypophyse. *Arch. path. Anat.*, **247**, 121-147.
- KRAUS, E. J. 1926. Die Hypophyse. *Handb. Spez. path. Anat. Histol.*, **8**, 810-950.
- KRAUS, E. J. 1927. Zur Pathologie des Morbus Addisoni. *Beitr. path. Anat.*, **78**, 283-296.
- LAVOUR, F. 1950. Recherches sur la relation entre les cellules hypophysaires à granulations orangées (cellules  $\epsilon$  de Romeis) et les phé-

- nomènes de lactation. *Compt. rend. Soc. biol.*, **144**, 248-249.
- LACY, D. 1954. The Golgi apparatus and neutral red granules in living and frozen-dried endocrine cells of the pancreas of the mouse. *J. Roy. Microscop. Soc.*, **74**, 1-9.
- LADMAN, A. J., AND BARNETT, R. J. 1954. Histochemical demonstration of protein-bound sulfhydryl and disulfide groups in cells of the anterior pituitary. *Endocrinology*, **54**, 355-360.
- LANGREBE, F. W., KETTERER, B., AND WARING, H. 1955. Hormones of the posterior pituitary. In *Ch. IX. The Hormones*, G. Pincus and K. V. Thimann, Eds., New York: Academic Press, Inc.
- LANGREBE, F. W., AND MITCHELL, G. M. 1958. The neural intermediate lobe hormone ("B"). *Proc. Roy. Soc. Med.*, **51**, 560-561.
- LAQUEUR, G. L. 1950. Cytological changes in human hypophyses after cortisone and ACTH treatment. *Science*, **112**, 429-430.
- LAQUEUR, G. L. 1951. The human hypophysis in diseases of the adrenal cortex. *Stanford Med. Bull.*, **9**, 75-87.
- LAQUEUR, G. L. AND FLUHMAN, C. F. 1942. Action of testosterone on the female rat hypophysis. *Endocrinology*, **31**, 300-302.
- LEVEQUE, T. F., AND SCHARRER, E. 1953. Pituitocytes and the origin of the antidiuretic hormone. *Endocrinology*, **52**, 436-446.
- LEWIS, D., LEE, F. C., AND ASTWOOD, E. B. 1937. Some observations on intermediin. *Bull. John Hopkins Hosp.*, **61**, 198-209.
- MARINE, D., ROSEN, S. H., AND SPARK, C. 1935. Effect of iodine and desiccated thyroid on anterior pituitary of goitrous and thyroidectomized rabbits. *Proc. Soc. Exper. Biol. & Med.*, **32**, 803-810.
- MARSHALL, J. M. 1951. Localization of adrenocorticotrophic hormone by histochemical and immunochemical methods. *J. Exper. Med.*, **94**, 21-30.
- MCLETCHE, N. G. B. 1942a. On staining the basophil cells of the human hypophysis with special reference to the abnormal basophil cells of Cushing's syndrome. *J. Endocrinol.*, **3**, 323-331.
- MCLETCHE, N. G. B. 1942b. The pituitary basophilism syndrome of Harvey Cushing. *J. Endocrinol.*, **3**, 332-346.
- MCMAHUS, J. F. A. 1946. Histological demonstration of mucin after periodic acid. *Nature, London*, **158**, 202.
- MCNARY, W. F. 1957. Progressive cytological changes in the hypophysis associated with endocrine interaction following exposure to cold. *Anat. Rec.*, **128**, 233-253.
- MCSHAN, W. H., AND MEYER, R. K. 1952. Gonadotrophic activity of granule fractions obtained from anterior pituitary glands of castrate rats. *Endocrinology*, **50**, 294-303.
- MCSHAN, W. H., ROZICH, R., AND MEYER, R. K. 1953. Biochemical properties of fractions obtained from rat anterior pituitary glands by differential centrifugation. *Endocrinology*, **52**, 215-222.
- MELLIGREN, J. 1945. The anterior pituitary in hyperperfusion of the adrenal cortex; an anatomical study with special reference to Syndrome Morgagni and notes on prostatic hypertrophy. *Acta path. et microbiol. scandinav.*, Suppl. 60, **22**, 1-177.
- MELLIGREN, J. 1948. Experimental investigation into genesis of adrenogenital syndromes by analysis of morphology of pituitary in hyperand hypofunction of adrenal cortex in rats. *Acta path. et microbiol. scandinav.*, **25**, 284-307.
- MIALHE-VOLOSS, C., AND BENOIT, J. 1954. L'intermédiaire dans l'hypophyse et l'hypothalamus du carard. *Compt. rend. Soc. biol.*, **148**, 56-59.
- MIKAMI, S. 1956. Cytological changes in the anterior pituitary of the dog after adrenalectomy. *J. Fac. Agric. Iwate Univ.*, **3**, 62-68.
- MIKAMI, S. 1957. The cytological significance of regional patterns in the adeno-hypophysis of the fowl. *J. Fac. Agric. Iwate Univ.*, **3**, 473-545.
- MORRIS, C. J. O. R., RUSSELL, D. S., LANGREBE, F. W., AND MITCHELL, G. M. 1956. The melanophore-expanding and corticotrophic activity of human pituitary tissue. *J. Endocrinol.*, **14**, 263-267.
- MÜLLER, W. 1958. On the pharyngeal hypophysis. In *Endocrine Aspects of Breast Cancer*, pp. 106-110. Edinburgh and London: E. & S. Livingstone, Ltd.
- NASSONOV, D. N. 1923. Über das Goltgische Binnetnetz und reine Beziehung zu der Sekretion. Untersuchungen über einige Amphibien-drüsen. *Arch. mikr. Anat.*, **97**, 136.
- NICHOLSON, W. M. 1936. Observations on the pathological changes in suprarenalectomized dogs, with particular reference to the anterior lobe of the hypophysis. *Bull. Johns Hopkins Hosp.*, **58**, 405-417.
- NIELSON, E. L. 1952. Studies on hereditary dwarfism in mice. XIII. Effect of the growth hormone and thyroxine on the growth of bones in mice with hereditary pituitary dwarfism. *Acta path. et microbiol. scandinav.*, **30**, 10-20.
- OLDHAM, F. K. 1938. The pharmacology and anatomy of the hypophysis of the armadillo. *Anat. Rec.*, **72**, 265-291.
- OLDHAM, F. K., LAST, J. H., AND GEILING, E. M. K. 1940. Distribution of melanophore-dispersing hormone in anterior lobe of cetaceans and armadillo. *Proc. Soc. Exper. Biol. & Med.*, **43**, 407-410.
- OLDHAM, F. K., MCCLEERY, D. P., AND GEILING, E. M. K. 1938. A note on the histology and pharmacology of the hypophysis of the manatee (*Trichechus inunguis*). *Anat. Rec.*, **71**, 27-32.
- OLIVEREAU, M., AND HERBLANT, M. 1954. Étude histologique de l'hypophyse de *Caccobarbuis gertsii* blgr. *Bull. Acad. Roy. Belg.*, **40**, 50-57.
- ORTMAN, R. 1954. Cytochemical study of the physiological activities in the pars intermedia of *Rana pipiens*. *Anat. Rec.*, **119**, 1-8.

- ORTMAN, R. 1956a. Two types of acidophils in the anterior pituitary of the frog and their relation to the periodic acid-Schiff reaction. *J. Histochem.*, **4**, 471-475.
- ORTMAN, R. 1956b. A study of some cytochemical reactions and of the hormone content of the adenohypophysis in normal and in genetic dwarf mice. *J. Morphol.*, **99**, 417-431.
- ORTMAN, R. 1956c. A study of the effect of several experimental conditions on the intermedin content and cytochemical reactions of the intermediate lobe of the frog (*Rana pipiens*). *Acta endocrinol.*, **23**, 437-447.
- ORTMAN, R., AND GRIESBACH, W. E. 1958. The cytology of the pars distalis of the wallaby pituitary. *Australian J. Exper. Biol.*, **36**, 609-618.
- PALADE, G. E. 1952. The fine structure of mitochondria. *Anat. Rec.*, **114**, 427-451.
- PALADE, G. E. 1953. An electron microscope study of the mitochondrial structure. *J. Histochem.*, **1**, 188-211.
- PALADE, G. E. 1955. A small particulate component of the cytoplasm. *J. Biophys. Biochem. Cytol.*, **1**, 59-68.
- PALADE, G. E. 1956. Intracisternal granules in the exocrine cells of the pancreas. *J. Biophys. Biochem. Cytol.*, **2**, 417-422.
- PALADE, G. E., AND PORTER, K. R. 1951. Studies on the endoplasmic reticulum. I. Its demonstration in cells *in situ*. *J. Exper. Med.*, **95**, 285-289.
- PALAY, S. L. 1945. Neurosecretion. VII. The preoptico-hypophysial pathway in fishes. *J. Comp. Neurol.*, **82**, 129-143.
- PALAY, S. L. 1953. Neurosecretory phenomena in the hypothalamohypophysial system of man and monkey. *Am. J. Anat.*, **93**, 107-127.
- PALAY, S. L. 1955. An electron microscope study of the neurohypophysis in normal, hydrated, and dehydrated rats. *Anat. Rec.*, **121**, 348.
- PALAY, S. L. 1957. The fine structure of the neurohypophysis. *Progr. Neurobiol.*, **2**, 31-41.
- PARDOL, A. V., AND WEATHERALL, M. 1955. The intracellular localization of oxytocic and vasopressor substances in the pituitary glands of rats. *J. Physiol.*, **127**, 201-212.
- PAYNE, F. 1942. The cytology of the anterior pituitary of the fowl. *Biol. Bull.*, **82**, 79-111.
- PAYNE, F. 1943. The cytology of the anterior pituitary of broody fowls. *Anat. Rec.*, **86**, 1-13.
- PAYNE, F. 1941. Anterior pituitary-thyroid relationship in the fowl. *Anat. Rec.*, **88**, 337-350.
- PAYNE, F. 1949. Changes in the endocrine glands of the fowl with age. *J. Gerontol.*, **4**, 193-199.
- PEARSE, A. G. E. 1948. Cytochemistry of the gonadotropic hormones. *Nature*, London, **162**, 651.
- PEARSE, A. G. E. 1949. The cytochemical demonstration of gonadotropic hormone in the human anterior hypophysis. *J. Path. & Bact.*, **61**, 195-201.
- PEARSE, A. G. E. 1951. The application of cytochemistry to the localization of gonadotrophin in the pituitary. *J. Endocrinol.*, **7**, xlviii-i.
- PEARSE, A. G. E. 1952. Observations on the localization, nature, and chemical constitution of some components of the anterior hypophysis. *J. Path. & Bact.*, **64**, 791-809.
- PEARSE, A. G. E. 1953. Cytological and cytochemical investigations on the foetal and adult hypophysis in various physiological and pathological states. *J. Path. & Bact.*, **65**, 355-370.
- PEARSE, A. G. E., AND RINALDINI, L. M. 1950. Histochemical determination of gonadotrophin in the rat hypophysis. *Brit. J. Exper. Path.*, **31**, 540-544.
- PEPLER, W. J., AND PEARSE, A. G. E. 1957. The histochemistry of the esterases of rat brain, with special reference to those of the hypothalamic nuclei. *J. Neurochem.*, **1**, 193-202.
- PETERSON, R. R. 1957. An electron microscopic study of pituitary basophiles in the guinea pig. *Anat. Rec.*, **127**, 346.
- PETERSON, R. R., AND WEISS, J. 1955. Staining of the adenohypophyses with acid and basic dyes. *Endocrinology*, **57**, 96-108.
- PORIS, E. G. 1941. Studies on the endocrines of reptiles. II. Variation in the histology of the hypophysis of *Anolis carolinensis*, with a note on the Golgi configuration in cells of the pars anterior and pars intermedia. *Anat. Rec.*, **80**, 99-121.
- PURVES, H. D. 1956. Hyalimination and basophil adenomata in the pituitary gland. *Proc. Roy. Soc. Med.*, **49**, 1014-1016.
- PURVES, H. D., AND GRIESBACH, W. E. 1946. Acidophil degranulation in relation to goitrogenic agents and extrathyroidal thyroxine synthesis. *Brit. J. Exper. Path.*, **27**, 170.
- PURVES, H. D., AND GRIESBACH, W. E. 1951a. The site of thyrotrophin and gonadotrophin production in the rat pituitary studied by McManus-Hotchkiss staining for glycoprotein. *Endocrinology*, **49**, 244-264.
- PURVES, H. D., AND GRIESBACH, W. E. 1951b. Specific staining of the thyrotrophic cells of the rat pituitary by the Gomori stain. *Endocrinology*, **49**, 427-428.
- PURVES, H. D., AND GRIESBACH, W. E. 1951c. The significance of the Gomori staining of the basophils of the rat pituitary. *Endocrinology*, **49**, 652-662.
- PURVES, H. D., AND GRIESBACH, W. E. 1952. Functional differentiation in the acidophil cells and the gonadotrophic basophil cells of the rat pituitary. *Proc. Univ. Otago Med. Sch.*, **30**, 27.
- PURVES, H. D., AND GRIESBACH, W. E. 1954. The site of follicle stimulating and luteinizing hormone production in the rat pituitary. *Endocrinology*, **55**, 785-793.
- PURVES, H. D., AND GRIESBACH, W. E. 1957a. A study on the cytology of the adenohypophysis of the dog. *J. Endocrinol.*, **14**, 361-370.
- PURVES, H. D., AND GRIESBACH, W. E. 1957b. Pituitary cytology in relation to thyrotrophic hormone secretion. *Ciba Foundation Colloquia Endocrinol.*, **10**, 51-57.
- PURVES, H. D., AND SURETT, N. E. 1959. A study of the hormone contents of the rostral and



- caudal zones of the pars anterior of the wallaby pituitary. *Australian J. Exper. Biol.*, **37**, 271-278.
- RACABOT, J. 1954. Mise en évidence de lipides complexes au niveau de l'hypophyse après inclusion à la paraffine. *Compt. rend. Soc. biol.*, **148**, 167-170.
- RAHN, H. 1939. The development of the chick pituitary with special reference to the cellular differentiation of the pars buccalis. *J. Morphol.*, **64**, 483-517.
- RAHN, H., AND PAINTER, B. T. 1941. A comparative histology of the bird pituitary. *Anat. Rec.*, **79**, 297-312.
- RASMUSSEN, A. T. 1933. The percentage of the different types of cells in the anterior lobe of the hypophysis in the adult human female. *Am. J. Path.*, **9**, 459-471.
- RASMUSSEN, A. T., AND GARDNER, W. J. 1940. Effects of hypophysial stalk resection on the hypophysis and hypothalamus of man. *Endocrinology*, **27**, 219-226.
- RENNELS, E. G. 1951. Use of acid hematein for staining acidophils of the rat hypophysis. *Anat. Rec.*, **3**, 652-662.
- RENNELS, E. G. 1953. Localization of phospholipids in the rat hypophysis. *Anat. Rec.*, **115**, 659-671.
- RENNELS, E. G. 1957. Two tinctorial types of gonadotrophic cells in the rat hypophysis. *Ztschr. Zellforsch.*, **45**, 464-471.
- RENNELS, E. G. 1958. Effects of lactation on the neurohypophysis of the rat. *Texas Rep. Biol. & Med.*, **16**, 219-231.
- REESE, J. B., KONEFF, A. A., AND AKIMOTO, M. B. 1939. Anterior pituitary changes following adrenalectomy in the rat. *Anat. Rec.*, **75**, 373-403.
- REESE, J. D., KONEFF, A. A., AND WALSMAN, P. 1943. Cytological differences between castration and thyroidectomy basophils in the rat hypophysis. In *Essays in Biology*, pp. 473-482. Berkeley: University of California.
- ROCHEFORT, G. J., AND SAFFRAN, M. 1957. Distribution of adrenocorticotrophic hormone in the pituitary gland. *Canad. J. Biochem. Physiol.*, **35**, 471-480.
- RODRIGUEZ, H. 1937. Systematische Untersuchungen am Hirnanhang einiger Säugtiere über die Brauchbarkeit der Färbung nach Berthinger-Burdorf zur Darstellung der Epithelien der Adenohypophyse. *Endokrinologie*, **19**, 151-160.
- ROKHLINA, M. L. 1940. Effect of gonadepinephrectomy on the structure of the anterior lobe of the hypophysis. *Compt. rend. Acad. Sc. U.S.S.R.*, **27**, 504-507.
- ROMEIS, B. 1940. Die Hypophyse. In *Handbuch der mikroskopischen Anatomie des Menschen*, von Mollendorff, Ed. Vol. 6, Part 3. Berlin: Julius Springer.
- RUSSELL, D. S. 1956. *Proc. Roy. Soc. Med.*, **49**, 1018-1019 (in discussion).
- RUSSELL, D. 1957. The pituitary gland (hypophysis). In *Pathology*, W. A. D. Anderson, Ed. St. Louis: C. V. Mosby Company.
- RUSSELD, A. B. 1957. The endocrine system. In *Analytical Pathology*, Ch. 5. New York: McGraw-Hill Book Company.
- RUSSELD, A. B., REINER, L., AND KLAUS, H. 1956. The endocrine significance of hypophysial tumors in man. *Am. J. Path.*, **32**, 1055-1075.
- SAXÉN, L., SAXÉN, E., TOIVONEN, S., AND SALIMÄKI, K. 1957. Quantitative investigation on the anterior pituitary-thyroid mechanisms during frog metamorphosis. *Endocrinology*, **61**, 35-44.
- SCHARRER, E. 1954. Neurosecretion and anterior pituitary in the dog. *Experientia*, **10**, 264-266.
- SCHARRER, E., AND SCHARRER, B. 1940. Secretory cells within the hypothalamus. *A. Res. Nerv. & Ment. Dis., Proc.*, **20**, 170-194.
- SCHARRER, E., AND SCHARRER, B. 1945. Neurosecretion. *Physiol. Rev.*, **25**, 171-181.
- SCHARRER, E., AND SCHARRER, B. 1954. Hormones produced by neurosecretory cells. *Recent Progr. Hormone Res.*, **10**, 183-210.
- SCHIEBLER, T. H. 1952. Zur Histochemie des neurosekretorischen Hypothalamisch-Neurohypophysären Systems (II Teil) *Acta Anat.*, **15**, 593-616.
- SCHLEIDT, J. 1914. Über die hypophyse bei feminierte Männchen und maskulierten Weibchen. *Zentralbl. Physiol.*, **27**, 1170.
- SCHÖEMANN, A. 1892. Hypophysis und Thyreoidea. *Arch. path. Anat.*, **129**, 310-336.
- SCRUGGS, W. M. 1939. The epithelial components of the teleost pituitary gland as identified by a standardized method of selective staining. *J. Morphol.*, **65**, 187-213.
- SEVERINGHAUS, A. E. 1932. Anterior pituitary changes referable to the reproductive hormones, and the influence of the thyroid and the adrenals on genital function. In *Sex and Internal Secretions*, E. Allen, Ed., p. 805. Baltimore: The Williams & Wilkins Company.
- SEVERINGHAUS, A. E. 1933. A cytological study of the anterior pituitary of the rat with special reference to the Golgi apparatus and to cell relationship. *Anat. Rec.*, **57**, 149-175.
- SEVERINGHAUS, A. E. 1939. Anterior hypophysial cytology in relation to the reproductive hormones. In *Sex and Internal Secretions*, 2nd ed., Allen, Danforth and Doisey, Eds., p. 1045-1087. Baltimore: The Williams & Wilkins Company.
- SIEKEVITZ, P., AND PALADE, G. E. 1958a. A cytochemical study on the pancreas of the guinea pig. I. Isolation and enzymatic activities of cell fractions. *J. Biophys. Biochem. Cytol.*, **4**, 203-218.
- SIEKEVITZ, P., AND PALADE, G. E. 1958b. A cytochemical study of the guinea pig. II. Functional variations in the enzymatic activity of microsomes. *J. Biophys. Biochem. Cytol.*, **4**, 309-318.
- SPIERSTEIN, E., NICHOLS, G. W., JR., GRIESBACH, W. E., AND CHAIKOFF, I. L. 1954. Cytological changes in the rat anterior pituitary from birth to maturity. *Anat. Rec.*, **118**, 593-620.
- SJÖSTRAND, F. S., AND HANZON, V. 1954. Ultra-

- structure of Golgi apparatus of exocrine cells of mouse pancreas. *Exper. Cell Res.*, **7**, 415-429.
- SMELSER, G. K. 1944. Differential concentration of hormones in the central and peripheral zones of the bovine anterior pituitary gland. *Endocrinology*, **34**, 39-43.
- SMITH, P. E., AND MACDOWELL, E. C. 1930. An hereditary anterior-pituitary deficiency in the mouse. *Anat. Rec.*, **46**, 249-257.
- SMITH, P. E., AND SMITH, I. P. 1923a. The response of the hypophysectomized tadpole to the intraperitoneal injection of the various lobes and the colloid of the bovine hypophysis. *Anat. Rec., Suppl.*, **25**, 150-151.
- SMITH, P. E., AND SMITH, I. P. 1923b. The topographical separation in the bovine anterior hypophysis of the principle reacting with the endocrine system from that controlling general body growth with suggestions as to the cell types elaborating these secretions. *Anat. Rec., Suppl.*, **25**, 150-151.
- SMITH, S. W. 1951. The correspondence between hypothalamic neurosecretory material and neurohypophysial material in vertebrates. *Am. J. Anat.*, **89**, 195-231.
- SLOPER, J. C. 1955. Hypothalamic neurosecretion in the dog and cat, with particular reference to the identification of neurosecretory material with posterior lobe hormone. *J. Anat.*, **89**, 301-316.
- SLOPER, J. C. 1957. Diabetes insipidus: the contribution of histochemical and isotope techniques to the investigation of its pathogenesis. *Proc. Roy. Soc. Med.*, **51**, 335-339.
- SOBER, H. A., AND PETERSON, E. A. 1958. Protein chromatography on ion exchange cellulose. *Fed. Proc.*, **17**, 1116-1126.
- SPEIDEL, C. C. 1919. Gland cells of internal secretion in the spinal cord of the skates. Carnegie Inst., Washington, No. 281, Dept. Marine Biol., **13**, 1-31.
- STEEDMAN, H. F. 1950. Alcian Blue 8 GS: a new stain for mucin. *Quart. J. Microsc. Sc.*, **91**, 477-479.
- STELMAN, S. L., KELLY, T. L., SEGALOFF, A., AND WEBER, G. F. 1956. Isolation of an apparently homogeneous follicle stimulating hormone. *Endocrinology*, **59**, 256.
- STUTINSKY, F., BONVALLET, M., AND DELL, P. 1949. Les modifications hypophysaires au cours du diabète expérimentale chez le chien. *Ann. endocrinol.*, **10**, 505-517.
- THORNTON, K. R. 1956. The action of ACTH and cortisone on the anterior pituitary. *Proc. Roy. Soc. Med.*, **49**, 1016-1018.
- TIMMER, R. F., AND FINERTY, J. C. 1956. Cytological and weight changes in the pituitary gland of the severely stressed rat. *Proc. Soc. Exper. Biol.*, **91**, 120-123.
- TÖNNIS, W., MÜLLER, W., OSWALD, F., AND BRILMAYER, H. 1951. Kann die Rachendachhypophyse eine vikariierende Funktion ausüben. *Klin. Wchnschr.*, **32**, 912-914.
- TUCHMANN-DUPLESSIS, H. 1953. Structural changes in the anterior pituitary with special reference to the adrenal cortex. *Ciba Foundation Colloquia Endocrinol.*, **4**, 33-53 (in discussion).
- TURNER, C. W. 1939. The mammary glands. In *Sex and Internal Secretions*, 2nd ed., Allen, Danforth and Doisy, Eds., Ch. II; pp. 740-803. Baltimore: The Williams & Wilkins Company.
- TYSLOWITZ, R. 1943. Corticotrophin obtained by ultrafiltration of pituitary extracts. *Science*, **98**, 225-226.
- VAN DYKE, H. B., CHOW, B. F., GREEP, R. O., AND ROTHEN, A. 1942. The isolation of a protein from the pars neuralis of the ox pituitary with constant oxytocic, pressor and diuresis-inhibiting activities. *J. Pharmacol. & Exper. Therap.*, **74**, 190-209.
- VOITKEVICH, A. A. 1937a. The role of the anterior lobe of the hypophysis in the growth and differentiation of anura. *Bull. Biol. et Med. exper. U.S.S.R.*, **3**, 255-257.
- VOITKEVICH, A. A. 1937b. The role of the anterior lobe of the hypophysis in the growth and differentiation of urodela. *Bull. Biol. et Med. exper. U.S.S.R.*, **3**, 258-259.
- VON SÖÖS, J. 1934. Vergleichende histologische. Untersuchungen über die Topographie und die Bedeutung der basophilen Zellen der Hypophyse. *Frankfurt. Ztschr. Path.*, **47**, 82-96.
- WEAVER, T. A., AND BUCY, P. C. 1940. The anatomical relationships of the hypophysial stem and the median eminence. *Endocrinology*, **27**, 227-235.
- WHEELER, R. S. 1943. Normal development of the pituitary in the opossum and its responses to hormonal treatments. *J. Morphol.*, **73**, 43-87.
- WILSON, W. D., AND EZRIS, C. 1954. Three types of chromophil cells of the adenohypophysis. *Am. J. Path.*, **30**, 891-899.
- WISLOCKI, G. B. 1929. The hypophysis of the porpoise (*Tursiops truncatus*). *Arch. Surg.*, **18**, 1403-1412.
- WISLOCKI, G. B. 1939. Note on the hypophysis of an adult Indian elephant. *Anat. Rec.*, **74**, 321-328.
- WISLOCKI, G. B., AND GEILING, E. M. K. 1936. The anatomy of the hypophysis of whales. *Anat. Rec.*, **66**, 17-41.
- WOLFE, J. M. 1935. The normal level of the various cell types in the anterior pituitaries of mature and immature female rats and further observations of cyclic changes. *Anat. Rec.*, **61**, 321-330.
- WOLFE, J. M. 1941. Effects of testosterone propionate on the structure of the anterior pituitaries of old male rats. *Endocrinology*, **29**, 969-971.
- WOLFE, J. M. 1943. The effects of advancing age on the structure of the anterior hypophysis and ovaries of female rats. *Am. J. Anat.*, **72**, 361-383.
- WOLFE, J. M., AND BROWN, A. D. 1942. Action of diethylstilbestrol on cytological characteristics of anterior pituitaries of female rats, together with certain observations on the effect of castration. *Endocrinology*, **31**, 467-478.
- WOLFE, J. M., AND CLEVELAND, R. 1933a. Cyclic

- histological variations in the anterior hypophysis of the albino rat. *Anat. Rec.*, **55**, 233-249.
- WOLFE, J. M., AND CLEVELAND, R. 1933b. Pregnancy changes in anterior hypophysis of albino rat. *Anat. Rec.*, **56**, 33-45.
- WOLFE, J. M., CLEVELAND, R., AND CAMPBELL, M. 1933. Cycle histological variations in the anterior hypophysis of the dog. *Ztschr. Zellforsch.*, **17**, 420-452.
- WOLFE, J. M., PHELPS, D., AND CLEVELAND, R. 1934. The anterior hypophysis of the rabbit during oestrus and pseudopregnancy. *Am. J. Anat.*, **55**, 363-405.
- WULZEN, R. 1914. The morphology and histology of a certain structure connected with the pars intermedia of the pituitary body of the ox. *Anat. Rec.*, **8**, 403-415.
- ZECKWER, I. T. 1936. Thyrotropic effects of pituitaries from cretin rats. *Am. J. Physiol.*, **117**, 518-524.
- ZECKWER, I. T. 1937. Morphological changes in the pituitaries of rats resulting from combined thyroidectomy and gonadectomy. *Am. J. Pathol.*, **13**, 985-992.
- ZECKWER, I. T. 1938a. Differences between castration cells and thyroidectomy cells of the pituitary of the rat in response to the administration of estrone and thyroid extract. *Am. J. Pathol.*, **14**, 773-782.
- ZECKWER, I. T. 1938b. The effect of combined thyroidectomy and gonadectomy on compensatory adrenal hypertrophy in unilaterally adrenalectomized rats. *Am. J. Physiol.*, **123**, 266-271.
- ZECKWER, I. T., DAVISON, L. W., KELLER, T. B., AND LIVINGOOD, S. C. 1935. The pituitary in experimental cretinism: structural changes in the pituitaries of thyroidectomized rats. *Am. J. Med. Sci.*, **190**, 145-157.
- ZEINER, F. M. 1952. Pituitary gonadotrophic fluctuation during pregnancy in the rat. *Anat. Rec.*, **113**, 255-267.

# 4

## PHYSIOLOGY OF THE ANTERIOR HYPOPHYSIS IN RELATION TO REPRODUCTION

*Roy O. Greep, Ph.D.*

PROFESSOR OF ANATOMY, HARVARD SCHOOL OF DENTAL MEDICINE, BOSTON

I. INTRODUCTION .....	241		
II. THE HYPOPHYSEAL GONADOTROPHINS .....	241		
A. Follicle-stimulating Hormone .....	242		
1. Chemical features .....	242		
2. Physiologic effects in females .....	243		
3. Physiologic effects in males .....	244		
4. FSH in relation to compensatory gonadal responses .....	244		
5. Assay .....	245		
B. Luteinizing Hormone (Interstitial Cell-stimulating Hormone) .....	245		
1. Chemical features .....	245		
2. Physiologic effects in females .....	246		
3. Physiologic action in males .....	246		
4. An extragonadal activity .....	247		
5. FSH and LH in relation to estrogen secretion .....	247		
6. FSH and LH, interactions .....	247		
7. Assay .....	248		
C. Luteotrophin (Prolactin) .....	249		
1. Chemical features .....	249		
2. Physiology of luteotrophic hormone (prolactin) .....	249		
3. Detection and assay of prolactin activity .....	250		
III. PITUITARY GONADOTROPHIC HORMONE CONTENT AND RELATED EVIDENCE OF SECRETORY ACTIVITY .....	250		
A. Phylogenetic Considerations .....	251		
1. Ascidians .....	251		
2. Fish .....	252		
3. Amphibians .....	252		
4. Reptiles .....	253		
5. Birds .....	253		
6. Mammals .....	254		
7. General considerations .....	255		
B. Age, Sex, Gonadectomy, and Reproductive Rhythms in Relation to Pituitary Gonadotrophins .....	256		
1. Fetal gonadotrophins .....	256		
2. Age and sex .....	256		
3. Gonadectomy .....	258		
4. Reproductive rhythms .....	259		
C. Effect of Dietary Restrictions on Pi-			
tuitary Gonadotrophic Potency and Function .....	261		
1. Underfeeding .....	261		
2. Vitamin deficiencies .....	262		
3. Deficiency in intake of protein or of specific amino acids .....	262		
IV. GONADAL-HYPOPHYSEAL INTERRELATIONS .....	263		
A. Immaturity .....	263		
B. Puberty and Maturity .....	264		
C. Effects of Estrogens on Follicle-stimulating Hormone Secretion .....	265		
D. Effect of Estrogen on Luteinizing Hormone and Luteotrophin Hormone Secretion .....	267		
E. Differential Effects of Gonadal Steroids on Follicle-stimulating Hormone and Luteinizing Hormone Secretion .....	268		
F. Effects of Androgens on Pituitary Gonadotrophins .....	268		
G. Other Steroids and Oxidation Products .....	271		
H. Effect of Progesterone on Pituitary Gonadotrophic Functions .....	271		
I. Neurohypophysial Influences on Gonadotrophin Secretion .....	272		
V. ANATOMIC FEATURES IMPORTANT TO MODERN CONCEPTS OF PITUITARY GONADOTROPHIC FUNCTION .....	272		
A. Innervation of the Hypophysis .....	273		
B. The Median Eminence and the Infundibular Stem .....	274		
C. The Hypophysial Portal Circulatory System .....	275		
D. The Hypothalamic and Hypophysial Mediated Sexual Functions .....	276		
1. Environmental stimuli .....	276		
2. Electrical stimulation of the hypothalamus .....	278		
3. Lesions in the hypothalamus .....	279		
4. Transection of the hypophysial stalk .....	280		
VI. REFERENCES .....	284		

## I. Introduction

The elucidation of the major functions of the anterior lobe of the pituitary gland will likely stand as an epic in the scientific achievements of the past half century. The series of discoveries which revealed that this part of the hypophysis exercises direct or indirect control over a wide spectrum of biologic processes opened a new physiologic frontier. In no part of this new territory was understanding to be encompassed more spectacularly than by the revelation that the reproductive processes of the Vertebrata as a whole are mediated by secretions of the pituitary gland. It is intriguing to dwell on the evolutionary emergence of this gland which has so wide a control over the growth and development of both somatic and genital structures of the vertebrate body. That this regulator of so many organs and processes arises embryologically from the lining of the oral cavity and that it bears an ancient, and perchance functional, relationship to the primitive diencephalon is intriguing. The significance of these matters belongs to the future, but of immediate concern are the relationships of the pituitary to sex functions and it is to these that attention is addressed in this chapter.

The coverage of literature has mainly been restricted to the period since the last edition of this work. The number of papers published in these years is large in proportion to the concomitant advancement of the subject. Owing to interruptions of work in reproductive physiology during World War II and the postwar emphasis on those aspects of pituitary physiology which relate to the adrenal cortex and the thyroid, interest in the study of gonadotrophic hormones waned. The papers cited, by no means a complete list, are important in one or more of the following respects: a pertinent contribution to knowledge, an intelligent correlation of significant physiologic data, useful theorizing, or a guide to the literature in this and related fields. In several instances reference is made to earlier works. These help to bring into perspective current information and thought.<sup>1</sup>

<sup>1</sup> The following review articles, books and monographs are especially pertinent and valuable: Hisaw, 1947; Evans and Simpson, 1950; Ershoff, 1952;

## II. The Hypophyseal Gonadotrophins

During fetal development and in infancy the gonads normally come under little or no important pituitary hormonal influences; a possible exception has been noted in the rabbit (Jost, 1951). Beyond infancy, however, it is clear that the arousal of gonadal functions, including the slow prepubertal, as well as the more spectacular spurt of pubertal development, is entirely dependent on gonad-stimulating hormones secreted by the anterior lobe of the hypophysis. There has been extensive exploration of the question as to whether the hypophysis secretes one or more than one gonadotrophin. Although there is yet very little, if any, knowledge of what the hypophyseal cells actually secrete, there is substantial evidence for the present widely held belief that in the mammals, at least, the anterior hypophysis secretes three trophic substances which stimulate and govern gonadal activity. These are: the follicle-stimulating hormone (FSH); the luteinizing hormone (LH) or interstitial cell-stimulating hormone (ICSH); and prolactin or lactogenic hormone, which has luteotrophic properties and has been termed luteotrophin (LTH).

The chemical evidence for the existence of separate gonadotrophins was reviewed by Li and Evans (1948) and Li (1949). Exhaustive expositions of the chemistry of the adenohypophysial luteotrophin, the first of the gonadotrophins to be isolated, have been provided by White (1949) and by Li (1957). The work on FSH and LH was brought up-to-date in 1955 by Hays and Steelman. The results of 25 years of work in these areas leave no doubt that the various biologic activities which have been demonstrated in whole anterior lobe tissue can be segregated by chemical fractionation procedures. The fact that these activities are identifiable with separate single protein fractions does not provide evidence that they are in fact secreted in the form of proteins with which the biologic activities have been identified. Furthermore, it is important to realize that

Nalbandov, 1953a; Sayers and Brown, 1954; Benoit and Assenmacher, 1955; Cowie and Folley, 1955; Benson and Cowie, 1957; Burrows, 1949; Parkes, 1952, 1956; Harris, 1955; Chester Jones and Eckstein, 1955; and Pickford and Atz, 1957.

the pituitary fractions equated with separate gonadotrophins have been regarded as chemical entities on criteria of purity which have been undergoing revision as advances are made in protein chemistry.

Several attempts have been made to find extractive procedures by which it would be possible to obtain all or nearly all the pituitary trophic hormones, including the gonadotrophins, from a common batch of starting material (Fevold, 1943; Schwenk, Fleischer and Tolksdorf, 1943; Koenig and King, 1950). Although success in this undertaking would, of course, greatly enhance the potential supply of anterior hypophyseal hormones, such procedures have thus far not proved feasible primarily because of the great differences in the solubility characteristics of the several hormones. Ellis (1958), however, has been able to obtain follicle-stimulating, luteinizing, and thyroid-stimulating hormone (TSH) in good yield from common batches of frozen whole sheep pituitaries.

Studies have been made of the biologic activity of cell-particulate fractions obtained by ultracentrifugation of homogenized anterior hypophyseal tissue, but it has not been possible to relate gonad-stimulating activity to any specific cellular organelle (McShan and Meyer, 1952; Brown and Hess, 1957).

By the use of histochemical procedures, not in themselves definitive, the secretion of FSH and LH has been ascribed, respectively, to specific cell types in the anterior pituitary (see chapter by Purves).

#### A. FOLLICLE-STIMULATING HORMONE

##### 1. *Chemical Features*

Chow, van Dyke, Greep, Rothen and Shedlovsky (1942), working with swine pituitary, obtained an FSH preparation that was free of other contaminating activities but was physiochemically heterogeneous. In 1949 Li, Simpson and Evans obtained an FSH fraction (ovine) that was free of other trophic factors and that behaved as a single protein by electrophoretic procedures and ultracentrifugation; it was not tested for constant solubility. The hormone FSH behaves as a protein and there is both chemical and histochemical evidence indicating

that it is a glycoprotein. FSH from swine and sheep has been variously estimated on the basis of incomplete data to have an isoelectric point of 4.5 and a molecular weight of 70,000 (Li, 1949).

That the carbohydrate residue in FSH may play an important role in physiologic activity is suggested by the finding that the FSH activity of anterior pituitary extracts is destroyed by salivary amylase and Taka-Diastase (McShan and Meyer, 1938; Abramovitz and Hisaw, 1939). The resistance of FSH to proteolysis, however, is notable. In fact, McShan and Meyer (1938), Chen and van Dyke (1939), Chow, Greep and van Dyke (1939), and McShan and Meyer (1940) obtained considerable purification of FSH by means of a selective inactivation or destruction of LH with crude trypsin. More recently, Steelman, Lamont, Dittman and Hawrylewicz (1953) and Steelman, Lamont and Balthes (1955, 1956) have used pancreatin digestion to prepare swine FSH having an activity of 2.5 to 9 times the Armour Standard (264-151X).

In 1950 van Dyke, P'an and Shedlovsky advanced the purification of swine FSH to about 80 to 85 per cent "pure." Since then, Li and Pederson (1952), Steelman and his associates (1953, 1955, 1956), and Leonora, McShan and Meyer (1956) have made additional improvements in the extraction, recovery, and purification of FSH with increased specific activity.

Steeleman, Kelly, Segaloff and Weber (1956) described the preparation of an "apparently homogenous follicle-stimulating hormone" with 30 to 50 times the activity of Armour Standard. By placing highly purified FSH on diethylaminoethyl cellulose and utilizing gradient elution, they obtained a 4- to 5-fold concentration of activity as determined by the augmentation test of Steelman and Pohley (1953). Preliminary study of this FSH in the ultracentrifuge and by paper electrophoresis revealed no evidence of heterogeneity. The molecular weight was calculated to be 29,000 as opposed to previous estimates. Total carbohydrate content was 7 to 8 per cent and was comprised of 50 per cent hexosamine and detectable quantities of mannose, galactose, and fucose. Tests for LH, TSH, adrenocorticotrophic hormone (ACTH), and somato-

trophic hormone (STH) were negative at the dosage level of 0.5 mg. of the FSH preparation. Latest among studies of purification of FSH is that of Ellis (1958). Using metaphosphoric acid and ethanol precipitation, he obtained a satisfactory concentrate of FSH which he was able to purify further by chromatography on diethylaminoethyl cellulose and starch electrophoresis at pH 4. This FSH preparation was electrophoretically monodisperse, free of LH and TSH, and had 30 to 40 times the potency of Armour Standard.

The development of satisfactory procedures for the isolation of FSH has been an exceedingly difficult problem and most workers are agreed that the methods are not finalized and that no product thus far obtained has satisfied all the modern criteria of purity. Certainly, also, there are too few studies with the highly purified preparations to establish the biologic characteristics of this hormone. The difficulty in ascribing to FSH the status of a homogeneous chemical compound is emphasized by the work of Steelman, Lamont and Baltes (1955, 1956) and by Steelman (1958). Using pancreatin digestion followed by chromatography on hydroxyl apatite, they obtained 3 FSH fractions, all with considerable relative activity, and are in doubt as to whether the pre-chromatographed material can be regarded as homogeneous.

There is no doubt, as we survey the vertebrates as a whole, that there is a pituitary factor immediately concerned in follicular maturation and to this extent follicle-stimulating hormone is a proper term. Caution should be exercised lest terminologic convenience be confused with the fact. Nevertheless, with modern methods of protein research it is very probable that a follicle-stimulating hormone will be isolated soon, and perhaps characterized as a polypeptide with known amino acid composition and sequence.

Whatever the precise nature of FSH, it is carried to its target organs by the blood. A preliminary study (McArthur, Pennell, Antoniadis, Ingersoll, Onley and Ulfelder, 1956) of postmenopausal plasma fractionated by the cold ethanol method of Cohn has revealed that the gonadotrophic activity, pituitary in origin and presumed to

comprise mainly FSH, is contained in Fractions II and III. This means that FSH as such may well be in combination with proteins not only in the pituitary but also in the blood stream.

## 2. *Physiologic Effects in Females*

One activity of the anterior lobe of the pituitary brings about the maturation of egg-bearing ovarian follicles. In mammals this property resides in the follicle-stimulating hormone as we know it and, in lower vertebrates, in a follicle-stimulating component of the hypophyseal complex. In mammals FSH acts on the ovary to promote the development of primary follicles into large fluid-filled vesicular structures of the type that engaged the attention of de Graaf in his search for the ovum. Primary follicles consist of a large oocyte surrounded by a single layer of flattened granulosa cells. As development proceeds, additional layers (6 to 9) of granulosa cells are proliferated to form a spherical mass with the ovum at the center. It is at this stage that the follicle becomes overtly sensitive to the action of FSH. Its further development, including the secretion of the follicular liquor, the mitotic proliferation of granulosa cells, and the molding of surrounding stroma into an investing layer of thecal cells, seems to be largely controlled by FSH. In all mammals studied, the growth and maturation of the ovum itself seems independent of the action of this hormone. In the monkey (Green and Zuckerman, 1947), rat (Mandl and Zuckerman, 1952), and hamster (Knigge and Leathem, 1956) the ovum reaches its full size well before the appearance of the follicular antrum.

FSH, by promoting follicular enlargement, controls to a large degree the growth of the ovary. In immature animals injected with different amounts of FSH, the weight of the ovary can be taken as a measure of FSH activity, providing the hormone injected is pure. The size to which the ovary can be forced to develop in either immature or adult mammals seems limited only by the number of responsive follicles available. With excessive dosage over periods of 5 to 10 or more days, ovaries of massive size have been developed in many species of birds (Witschi, 1955) and mammals (Ch-

sida, Meyer, McShan and Wisnicky, 1943; Dowling, 1949; Marden, 1952), including man (Davis and Hellbaum, 1944; Maddock, 1954). In the absence of luteinizing hormone, a situation insured by removal of the recipient animal's own hypophysis, FSH-stimulated ovaries present the appearance of being a mass of translucent cystic follicles. During a normal estrous cycle the number of follicles developing to maturity differs among species, but for any given species the number is quite constant (Brambell, 1956). Inasmuch as the size of the ovaries in the continuous (nonseasonal) breeder remains reasonably constant, it follows that the level of FSH stimulation must also be maintained at a similar norm. Follicular enlargement, which is brought about in large measure by the accumulation of antral liquor, occurs at a constant rate for any given species (Hisaw, 1947; Brambell, 1956). Accordingly, when ovarian enlargement is induced with increasingly greater dosages of exogenous FSH, the growth of individual follicles is not accelerated but more and more follicles are brought to maturity; the number, however, is not precisely proportional to the dose. The simultaneous development of an excessive number of Graafian follicles is the basis of the many demonstrations of artificially induced superovulation and superfetation in rats (Evans and Simpson, 1940), rabbits (Pincus, 1940; Parkes, 1943), sheep (Zawadowsky, 1941; Hammond, Jr., Hammond and Parkes, 1942; Casida, Warwick and Meyer, 1944), and cattle (Dowling, 1949; Hammond, Jr., 1949). The administration of FSH to immature animals hastens the maturation of the ovaries and leads to marked sexual precocity in all mammals tested, including the monkey (Simpson and van Wagenen, 1953) and cattle (Casida, Meyer, McShan and Wisnicky, 1943). Inasmuch as FSH activity may be restricted to the growth of follicles, accelerated puberty in the instances noted must have occurred in part through the concomitant secretion of endogenous gonadotrophins, among which LH would be primarily necessary.

That FSH secretion fluctuates rhythmically during reproductive cycles in sexually mature female mammals is suggested by the

evidence of Simpson, van Wagenen and Carter (1956), showing an increase in the level of pituitary FSH content during the follicular phase of the menstrual cycle in monkeys. This is in general agreement with the older literature on other mammals (van Dyke, 1939; Smith, 1939). On the other hand, the possibility that rhythmic fluctuation in the secretion of gonadotrophin may not be confined to FSH is discussed below.

### 3. *Physiologic Effects in Males*

In males FSH acts on the spermiogenic cells in the testes with the same selectivity that it exhibits for germinal tissues in the female gonad. The growth of the testes is predominantly due to FSH and is a reflection of an increase in the size of the seminiferous tubules and of spermatogenic activity (Greep and Fevold, 1937; Greep, van Dyke and Chow, 1942; Simpson, Li and Evans, 1951). When FSH is administered to immature male rodents the size of the testes is greatly increased, but an acceleration of the appearance of fully formed spermatozoa has not been observed. True sexual precocity in males has not, therefore, been obtained, even when every other aspect of the reproductive system is fully developed. Nelson (1952) cited evidence for the view that FSH may be responsible only for the proliferation of spermatogonia and primary spermatocytes. He speculates that an androgenic influence may participate in the final stages of spermatogenesis.

Testes developed under the stimulation of exogenous FSH exhibited no change in the number, appearance, or secretory activity of the intertubular cells of Leydig (Greep and Fevold, 1937; Greep, van Dyke and Chow, 1942; Simpson, Li and Evans, 1951). The unchanged male accessory sexual structures register clearly the fact that no androgen was produced as a result of the treatment.

### 4. *FSH in Relation to Compensatory Gonadal Responses*

A difference in the responses of male and female gonads to FSH is that under exogenous FSH stimulation the testes do not develop beyond their maximal normal adult size as do the ovaries. It has been noted that the sexes also differ in the degree of com-



compensatory hypertrophy which is elicited by unilateral gonadectomy, a response that is primarily elicited by FSH. The observation by Carmichael and Marshall (1908) that unilateral ovariectomy leads to compensatory hypertrophy of the remaining ovary is now commonplace. Similar experiments on the male were not reported until 1940 (Addis and Lew). Compensatory gonadal hypertrophy is much less pronounced in the male; the 50 per cent of testis mass remaining after unilateral gonadectomy increases only to 56 per cent of the weight of paired gonads of comparable controls, whereas the ovary increases up to 70 per cent. Clearly, in no instance is all the lost tissue regained through compensatory hypertrophy. It is of incidental interest in this connection that Edwards (1940) showed that unilateral castration in adult male animals leads to a halving of the sperm count. In the unilaterally ovariectomized female it is well established that the opposite ovary sheds at each ovulation the full number of eggs characteristic of the species (Asdell, 1924; Brambell, 1956). It is also of interest that in the unilaterally spayed rat the number of primary oocytes remains at the level normal for one ovary (Mandl and Zuckerman, 1950), indicating that FSH, as suggested by most older studies, does not influence oogenesis.

##### 5. Assay

In recent years the ability of FSH to synergize with human chorionic gonadotropin (HCG) has been utilized in the development of methods for the bioassay of FSH. The end point is weight of ovaries from immature rats (Evans and Simpson, 1950; Steelman and Pohley, 1953) or mice (Brown, 1955) which have also been injected with a constant and substantial amount of HCG. These methods are more sensitive than other, older assay procedures involving ovarian weight increase following injection of FSH alone into immature, intact rats or mice, but they are less specific than the assay based on ovarian weight increase (Evans, Simpson, Tolksdorf and Jensen, 1939) or re-establishment of minimal follicular growth (histologic) in hypophysectomized immature rats (Evans and Simpson, 1950). The methods of Steelman

and Pohley and of Brown have clear advantages over the indirect assay based on the weight of the uteri in FSH-injected, intact, immature mice as introduced by Klinefelter, Albright and Griswold (1943).

Testis weight increments in hypophysectomized male rodents serve as a convenient measure of FSH activity, provided, however, that the FSH is biologically pure (Greep, van Dyke and Chow, 1940; Simpson, Evans and Li, 1950).

The activity of FSH in an aqueous medium is known to be augmented by a variety of substances. The explanation of the effectiveness of these cofactors is unknown, but several of them such as heme (McShan and Meyer, 1941) and zinc and copper salts, probably merely delay absorption and provide a more sustained effective blood level of the hormone.

#### B. LUTEINIZING HORMONE (INTERSTITIAL CELL-STIMULATING HORMONE)

##### 1. Chemical Features

Working independently, Li, Simpson and Evans (1940a, b) and Shedlovsky, Rothen, Greep, van Dyke and Chow (1940) isolated LH from sheep and swine pituitaries, respectively. The two preparations have similar physiologic properties (Greep, van Dyke and Chow, 1942; Simpson, Li and Evans, 1942a, b), but they differ chemically (Chow, van Dyke, Greep, Rothen and Shedlovsky, 1942) and are distinguishable by immunologic methods (Chow, 1942). The sheep hormone had an isoelectric point of 4.6 and a molecular weight of 40,000, whereas that of swine had an isoelectric point of 7.45 and a molecular weight of 100,000. Ellis (1958) has recently achieved a considerable concentration of LH activity, using cation exchange resins. Squire and Li (1959), using a modified extractive procedure, chromatographic separation, and zone electrophoresis on starch, obtained two equally active "ICH" proteins; one of these, " $\beta$ -ICH," has been partially characterized: it has an isoelectric point near 7.3 and a molecular weight (calculated) of approximately 30,000. This fraction had "a high degree of homogeneity," showed no evidence of contamination with other pituitary hormones, and was active by the ventral prostate test at a total dose of 0.5  $\mu$ g.

LH, like FSH, is a glycoprotein. The biologic activity of LH is far more resistant to glycolytic enzymes than is that of FSH; its resistance to proteolytic enzymes, however, is much less.

The available preparations of LH seem to be more satisfactory than those of FSH in point of comprising a hormone as a chemical entity. However, LH, as indicated by the recent work of Squire and Li (1959), may in turn reveal its biologic activity in some small part of a protein complex.

### 2. *Physiologic Effects in Females*

The many early studies based on the action of LH extracts injected into intact immature rats are uninformative, since the participation of endogenous gonadotrophins cannot be excluded nor safely discounted. Histologically, the action of LH has been detected with certainty in long-term hypophysectomized immature female animals by repair of the atrophic ovarian interstitial cells (Simpson, Li and Evans, 1942a, b).

The ovarian manifestations of the action of LH administered to intact immature female animals are notably inconspicuous. There is no increase in ovarian weight and no evidence that LH promotes the secretion of gonadal hormones. The interstitial cells appear a little more swollen than in untreated animals, and in guinea pigs in particular so-called pseudolutein bodies may appear. Conversely, the effect of LH on ovaries of adult rats are evident macroscopically. There occur an excessive number of ovulated follicles, many hemorrhagic follicles, and widespread luteinization of medium to large unruptured follicles, the ovaries being generally enlarged due to the synergism of the administered LH with endogenous FSH.

In hypophysectomized immature female rats under treatment with FSH, the notable effect of introducing LH is to impose an intensification of the enlargement of the ovaries and to promote a sudden growth of the reproductive tract (Greep, van Dyke and Chow, 1942). That this latter effect is due to the initiation of estrogen secretion is unequivocal. The cells of the theca interna which remain atrophic under FSH stimulation swell and acquire the cytologic

and histochemical criteria of actively secreting cells only if LH, among the pituitary gonadotrophins, is administered.

The importance of LH in bringing about the secretion of the ovarian hormone estradiol-17 $\beta$  has been mentioned. The facts that the thecal cells are maintained in a stimulated condition and that continuous uterine growth occurs during the follicular phase of a reproductive cycle suggest that LH is secreted during this time. Other lines of evidence likewise indicate that LH not only may be secreted throughout each estrous or menstrual cycle, but that it may play a dominant role in sexual periodicity. As early as 1937 Dempsey expressed the view that, as a step in accounting for the estrous cycle, it is necessary to assume that fluctuations occur in the secretion of LH, thus bringing about ovulation and corpus luteum formation. Indeed, McArthur, Ingersoll and Worcester (1958) reported a marked elevation in the urinary excretion of LH by women at the midpoint of the normal ovulatory menstrual cycle. This view is further supported by the fact of persistent estrus in rats and guinea pigs (for reviews of literature on spontaneously occurring or induced persistent estrus, see Nounura, 1958 and chapter by Everett) in which the causative factor appears to involve an inability to elicit a discharge of LH by reflex neurogenic mechanisms.

Although meager study has been made of the ovulating property of pure LH, it is known to have this function (Greep, Chow and van Dyke, 1942; Hisaw, 1947). There seems little reason to suppose that the pure hormone would behave differently in this respect from preparations having some FSH contamination. From information available, ovulation may, with reasonable assurance, be ascribed to a sudden elevation in the secretion of LH. Once ovulation has taken place, the conversion of the follicle into a luteinized body—a corpus luteum—is unquestionably attributable to LH action.

### 3. *Physiologic Action in Males*

The primary effect of LH on the male gonad is to promote the maturation, maintenance or repair of the interstitial tissue leading to the elaboration of androgenic hormone (Greep, Fevold and Hisaw, 1936;

Fraenkel-Conrat, Li, Simpson and Evans, 1940). This function is most clearly demonstrated by the injection of LH into hypophysectomized, immature male rats after hypophyseal deficiency has resulted in marked testicular atrophy. In these animals the shrunken, spindle-shaped, and cytochemically empty cells of Leydig are quickly restored to the swollen, epitheloid, lipid-rich type. The lipid vacuoles exhibit histochemical reactions that are characteristic of, but not necessarily specific for, steroidal substances. More specifically, the seminal vesicles, prostate and Cowper's glands undergo enlargement and each elaborates its special exocrine secretion in proof of induced testicular endocrine function. The testes also enlarge somewhat, due to swelling of the tubules and some minimal stimulation of their spermatogenic epithelium. The latter response is believed to be brought about by the direct spermatogenic action of testosterone *per se* and can, in fact, be duplicated by the injection of this hormone alone.

In hypophysectomized adult male rats given LH from the time of operation, the entire reproductive system, including all components of the testes, is maintained in a normal condition (Greep and Fevold, 1937). Here it is presumed that the action of LH is confined to stimulation of the interstitial cells, because all other aspects of the response can be duplicated by exogenous androgens.

#### 4. An Extragonadal Activity

The possibility that gonadotrophins have an effect on the adrenal cortex has always been attractive. However, only in the mouse has any clear-cut action been demonstrated. LH has a trophic influence on the so-called X-zone in the adrenal glands of mice (Chester Jones, 1949). This zone of highly eosinophilic cells is present at birth and disappears at puberty in the males and during the first gestation in females. Chester Jones (1950) found that although the zone persists after hypophysectomy in prepubertal mice, the cells therein revert to an atrophic state. It seemed likely, then, that the zone might be responsive to a factor from the pituitary. A check of available preparations revealed that extracts rich in LH were markedly trophic to the X-zone. Neither

FSH nor ACTH had any beneficial action in this regard. These findings fit nicely with the fact that the X-zone reappears after castration of postpubertal male mice (Howard, 1939), *i.e.*, at a time when the secretion of LH is greatly increased (for a review see Chester Jones, 1955, 1957).

#### 5. FSH and LH in Relation to Estrogen Secretion

The relation of FSH to estrogen secretion by the ovary has not been fully elucidated. Present knowledge in this area is deficient mainly because there has been little opportunity to study the activity of FSH as an entity free of LH with which it exhibits synergism. Acting with but minute amounts of LH, the quantitative responses to FSH are considerably enhanced as determined by the growth response of the female gonad (reviewed by Fevold, 1939, and by Evans and Simpson, 1950), yet the qualitative nature of the response may not be altered (Fraenkel-Conrat, Li, Simpson and Evans, 1941). To the extent of present knowledge, biologically pure FSH does not elicit the secretion of estrogen by the ovary of the hypophysectomized rat, and there is convincing evidence that it also does not evoke the secretion of androgen by the testes of similarly operated animals (Fevold, 1939; Greep, van Dyke and Chow, 1942; Evans and Simpson, 1950; Simpson, Evans and Li, 1950; Simpson, Li and Evans, 1951). However, FSH does play an essential and possibly even a primary role in the promotion of estrogen secretion by the ovary, inasmuch as it prepares the follicular apparatus on which LH can act to promote estrogen production. That the injection of highly purified FSH preparations into intact, immature rats and mice (Moon and Li, 1952; Thomopoulos and Li, 1954) has evoked the secretion of estrogen is explicable, perhaps, on the basis of endogenous LH release.

#### 6. FSH and LH, Interactions

LH is believed to interact in some manner with FSH at the ovarian level to produce greater stimulation than could be expected on the basis of the sum of the separate actions of these hormones. This effect has also been termed synergism or potentiation. It is a real and striking phenomenon

non, for which no satisfactory explanation is available. The principle of potentiation has been employed extensively to intensify artificially induced gonadal stimulation in sheep and cattle (Hammond, Jr. and Parkes, 1942; Casida, Meyer, McShan and Wisnicky, 1943).

An interplay between FSH and LH seems to operate in the accomplishment of ovulation. The ovulatory response to LH is well known to be intensified when acting in conjunction with FSH (Foster, Foster and Hisaw, 1937; Pincus, 1940; Chang, 1947a, b; Hisaw, 1947; Marden, 1952). The reader is referred to Hisaw (1947) for a thoughtful analysis of the literature. FSH acting alone in hypophysectomized animals will bring follicles to maturity, but seldom does it lead to their rupture (Knobil, Kostyo and Greep, 1959). LH, on the contrary, given as a quick acting stimulus in the presence of ripe follicles, is an efficient ovulator. Inasmuch as the exact nature of the ovulatory stimulus has not been elucidated, the term "ovulatory hormone" has been widely used. It has the advantage of being less committal as to the nature of the factors operating. In reality, it would be a very difficult matter to test the ovulating capacity of LH in the complete absence of FSH, since only near-mature follicles can be ovulated, and their existence is dependent on the action of FSH.

Rapid involution and disappearance of persisting corpora lutea in hypophysectomized adult rats (Bunde and Greep, 1936; Greep, 1938) was induced by injecting impure LH extracts and combinations of FSH and LH. Although pure LH did not produce the histolytic response, it is worth noting that it also did not elicit any maintenance of luteal function (Greep, van Dyke and Chow, 1942).

When FSH and LH were administered concurrently to intact or hypophysectomized, immature male rats a synergism was noted in respect to the increase in weight of the testes (Greep, Fevold and Hisaw, 1936).

### 7. Assay

Several means are available for detecting the activity of LH, but no one has proved fully satisfactory as a means of quantifying this hormone. Oldest of these methods is

the augmentation and luteinization test, as developed in the laboratory of Fevold and Hisaw. It involved a comparison of the qualitative ovarian response of intact, immature female rats to FSH alone as opposed to that of animals receiving FSH and LH simultaneously. A positive test for LH was manifest by augmentation of the ovarian weight and induction of extensive luteinization, resulting in what has often been termed "mulberry ovaries." When hypophysectomized test animals were employed, the results were less striking both quantitatively and qualitatively, but interference by endogenous LH was precluded.

The possibility of using the weight increase of the accessory sexual structures in immature male rats as a test for LH suggested itself from studies of the effects of the separate gonadotrophins in male animals. The ventral lobe of the prostate was the most sensitive. Employing hypophysectomized animals and pure LH, Greep, van Dyke and Chow (1941) demonstrated a satisfactory dose-response relationship. The test is simple, offers an objective measurement, and is moderately sensitive. It has the disadvantage of being indirect—the prostate response is androgen-mediated and reflects the action of LH on the testicular Leydig cells. The specificity of the prostate test for LH has been questioned by Segaloff, Steelman and Flores (1956). Pursuant to a report by Grayhack, Buncie, Kearns and Scott (1955) that prolactin enhanced the ventral prostate response to testosterone in castrated rats, Segaloff and his colleagues reported that prolactin sensitized the ventral prostate to the action of androgen secreted in response to LH. Lostroff and Li (1956) were not able to confirm that prolactin synergizes with testosterone, and Lostroff, Squire and Li (1958) found a strain variation with respect to the specificity of the ventral prostate as a test for ICSH. When the Long-Evans strain of rats was used, neither prolactin nor growth hormone, or any combination of these, altered the prostatic response to exogenous ICSH; with the Sprague-Dawley strain both growth hormone and lactogenic hormone effected significant enhancement of the response to ICSH. It seems that hypophysec-

tomized animals of any strain can be used for the assay of purified ICSH, but only those of the Long-Evans strain are suitable for the assay of impure preparations. Loraine and Diezfalusy (1958) concluded that the response of the ventral prostate of the hypophysectomized immature male rat to human menopausal gonadotrophin and HCG is not affected by the simultaneous administration of prolactin. Most important, perhaps, is the fact that FSH does not affect the prostatic assay for LH (Greep, van Dyke and Chow, 1941; Lostroh, Squire and Li, 1958).

According to Lostroh, Squire and Li (1958), "the hypophysectomized male rat of the Long-Evans strain has been a satisfactory animal for assaying preparations of ICSH when the weight of the ventral prostate is used as a measure of the activity and the response is represented as a logarithmic function of the dose. . . . The sensitivity of the assay is such that a total dose level of from 0.010 to 0.060 mg. is sufficient for assay purposes when the subcutaneous route is employed."

The Weaver finch test for LH, developed by Witschi (1940, 1955), is gaining acceptance as a valuable means of identifying this gonadotrophin (Segal, 1957). The test is carried out on African finches of the genera *Euplectes* and *Steganura*. Regenerating white feathers of the ventral pterylae in females or in males in eclipse plumage react to a single injection of LH by the formation of a black bar formed as a result of melanin deposition. The test is held to be specific for pituitary LH, but the evidence for this view is not yet conclusive. The reaction is independent of the sex glands. The observation that the Weaver finch test does not detect LH in menopausal urine (Witschi, 1955) as does the ventral prostate method (Greep and Chester Jones, 1950b; Loraine and Diezfalusy, 1958) needs further exploration.

Evidence submitted within the past year (Parlow, 1958) suggests that LH produces a fall in ascorbic acid content of the ovaries of pseudopregnant rats and promises to form the basis of a further and much more sensitive means of assaying the luteinizing hormone.

## C. LUTEOTROPHIN (PROLACTIN)

### 1. Chemical Features

Prolactin has been isolated in a form satisfying all the available physicochemical criteria of protein homogeneity and exhibiting no biologic activity other than that believed to be attributable to the hormone (for latest evidence see Li, 1957). Prolactin was the first in this category of protein hormones to be obtained in crystalline form (White, Catchpole and Long, 1937; White, 1943)—a notable achievement even though crystallization is no necessary indication of purity. Prolactin has mainly been obtained from the hypophyses of beef and sheep and although there may be minor species differences in the composition of the hormone as indicated by a slight difference in solubility, the preparations otherwise behave identically. They have an isoelectric point of 5.7 and a molecular weight of about 3200 (White, 1949).

### 2. Physiology of Luteotrophic Hormone (Prolactin)

Riddle, Bates and Dykshorn (1932) proposed the term prolactin to describe a pituitary activity which stimulated the crop sac of pigeons. In mammals prolactin was shown to possess also lactogenic and luteotrophic activity. It has not been unequivocally demonstrated that prolactin, lactogenic hormone, and luteotrophin are identical nor that luteotrophic manifestations are essential for luteal function except in the rat. For the purposes of this chapter, however, it is regarded as semantically legitimate to discuss LTH as a gonadotrophin, although scientifically neither its activity nor its identity with prolactin has been rigorously proved.

As noted, the rat is the only animal in which a luteotrophic action of prolactin has been conclusively demonstrated (Astwood, 1941; Cutuly, 1941; Evans, Simpson and Lyons, 1941; Evans, Simpson, Lyons and Turpeinen, 1941). Confirmatory observations have been reported by Lyons (1942), Tobin (1942), Fluhmann and Laqueur (1943), Everett (1944), Sydnor (1945), Greep and Chester Jones (1950a). Tests of the luteotrophic action of prolactin in other

species have not been encouraging. Intensive treatment with prolactin has singularly failed to prolong the functional life of the corpus luteum in monkeys (Hisaw, 1944; Bryans, 1951) and women (Holmstrom and Jones, 1949; Bradbury, Brown and Gray, 1950). By administering prolactin along with HCG during the postovulatory phase of the cycle in regularly menstruating women, Fried and Rakoff (1952) prolonged the functional life of the corpus luteum up to 13 days but neither hormone given alone was effective. These findings suggest that LTH may only act in synergism with a luteinizing hormone in man.

By recent demonstration, the lactogenic hormone appears to have a luteotrophic action in sheep (Moore and Nalbandov, 1955). The corpora lutea of anestrus ewes, ovulated with pregnant mare serum gonadotrophin, were maintained in a functional state for 20 to 30 days by daily injections of 200 I.U. of prolactin. Without such treatment the newly ovulated corpora lutea regressed rapidly. However, since the prolactin-treated animals were intact and their ovaries were heavily luteinized, the authors could not be certain that the prolongation of the functional life of the corpora lutea was attributable solely to the injected hormone. The testing of LTH in the recently ovulated and hypophysectomized rabbit (which seems not to have been done) would furnish valuable basic information.

### 3. Detection and Assay of Prolactin Activity

Luteotrophic hormone produces no conspicuous morphologic changes in the mammalian ovary; the response can in fact only be detected by demonstrating that preformed corpora lutea are functional. Luteotrophic activity *per se*, therefore, cannot be estimated directly in mammals, but rests on the evocation of progesterone secretion so that tests for LTH (reviewed by Astwood, 1953) are, in effect, tests for progesterone. Thus in the appropriately prepared rat LTH activity can be demonstrated qualitatively and a rough estimate of potency made by the appearance of deciduomas (Astwood, 1939; Lyons, Li, Johnson and Cole, 1953), maintenance of early gestation (Cutuly, 1941, and 1942), interruption of estrous

cycles (Deselin, 1949; Mayer and Canivenc, 1951), and appearance of diestrial smears in HCG-treated hypophysectomized rats (Astwood, 1941; van der Kuy, van Soest and van Prooye-Belle, 1953). In other mammals tests for LTH likewise hinge on the demonstration of some progesterone-like effect; these vary with the species (Cowie and Folley, 1955).

In practice the assumption is made that prolactin and luteotrophin are identical, and luteotrophic preparations are assayed by measurement of their capacity to stimulate the pigeon crop sac as determined by either the "systemic crop weight" method introduced by Riddle, Bates and Dykshorn (1933) or the "local micromethod" of Lyons and Page (1935). Modifications have been introduced in the "weight" method by Clarke and Folley (1953), and in the "local" method by Lyons (1937) and Reece and Turner (1937). (For detailed review of assay literature see White, 1949, or Cowie and Folley, 1955.)

### III. Pituitary Gonadotrophic Hormone Content and Related Evidence of Secretory Activity

A valuable method of studying the physiology of the pituitary gland is to remove it at autopsy or by surgery and ascertain the nature and quantity of gonad-stimulating hormone activity residual within the gland as shown by the gonadal response elicited in some appropriate recipient test animal, *i.e.*, immature rat, mouse, chick, pigeon. Early investigators relied mainly on implanting the fresh gland or injecting minced tissue, but this procedure is quantitatively unreliable inasmuch as the tissue tends to remain viable for an indeterminate time (Hellbaum and Greep, 1940). This difficulty was obviated by freezing (Fraenkel-Conrat, Simpson and Evans, 1940a) or by desiccating the glands in acetone followed by trituration in water or saline. As an alternative procedure, the pituitary glands of small animals can be crushed between glass slides, then speedily air-dried and recovered as a powder, without loss of potency (Kupperman, Elder and Meyer, 1941). Others preferred to test fresh ground homogenate of the pituitary tissue.

Pituitary gonadotrophic potency, a repre-

sentation of the amount of gonadotrophins present at the moment of death, is a resultant of the rate of synthesis and the rate of liberation. Whether such potency measurements provide any reasonable clue to the actual rate of secretion has been debated. The significance of such measurements is enhanced by the preponderance of cases in which the potency has correlated well with function, as revealed by the gonads and reproductive tracts of the donors (Meyer, Biddulph and Finerty, 1946; Robinson and Nalbandov, 1951; Kammlade, Welch, Nalbandov and Norton, 1952; Balm, Lorenz, Bennett and Albert, 1953a; Greeley and Meyer, 1953; Nalbandov, 1953b), a review; Simpson, van Wageningen and Carter, 1956). These correlations, however, were not always close and in a few instances, as noted elsewhere (page 261), pituitary potency and function diverged sharply. As long ago as 1939 Smith surmised that the usefulness of whole gland assays in the study of pituitary physiology had been nearly fulfilled. The prediction seemed reasonable but the technique, with some refinements, is still widely used and is one of the important means of gaining insight concerning the probable level of gonadotrophic function. It would be exceedingly helpful to be able to determine the blood level of the gonadotrophins, but even this would not reflect the rate of entry of the gonadotrophins into the blood stream unless the rate of destruction and excretion were also evaluated.

For the most part the levels of circulating gonadotrophins in normal animals have been found to be very low and are generally below the sensitivity of the available criteria for detecting them. Significant gonadotrophic activity has not been found in the blood or urine of ruminants (reviewed by Benson and Cowie, 1957) and the fact has been re-emphasized by the circumstance that no trace of such activity was found in volumes of sheep blood as large as 500 ml. (Bassett, Sewell and White, 1955). Normal rat plasma has also yielded consistently negative results except for one unconfirmed report of a trace of LH activity (Hellbaum and Greep, 1943). The plasma of gonadectomized rats, however, like the plasmas of menopausal women or gonadectomized men and women, was early found to contain

demonstrable gonadotrophic activity (Emery, 1932). Later, Hellbaum and Greep (1943) reported finding FSH, but no LH, in 10 ml. plasma from castrated male rats. Recently this result has been confirmed in substance by Cozens and Nelson (1958). Using closely spaced injections, they administered to hypophysectomized, immature female rats up to 24 or 32 ml. plasma from spayed adult female rats over a 4-day period; although they found a clear indication of FSH activity, ICSH was not apparent.

#### A. PHYLOGENETIC CONSIDERATIONS

The end points of cross-species testing of pituitary glands for gonadotrophic potency have comprised mainly gonad stimulation in immature male and female rats and mice and in 1-day-old male chicks, ovulation in estrous rabbits or pregnant mice (Ladman and Runner, 1951), ovulation or spermiation in frogs, and coloration of sparrow bill or Weaver finch feathers. The conditions of the assay have varied greatly; the test animals have been of different ages at the start of treatment; they have been hypophysectomized in one study and intact in the next; the dosage has been expressed in integers or fractions of whole glands or as milligrams, wet weight or dry weight, of pituitary tissue. The data often do not permit comparisons of assays of pituitaries from a given species, leaving aside the difficulties of making interspecies comparisons. The extensive literature on this topic has been reviewed repeatedly (Smith, 1939; van Dyke, 1939; Burrows, 1949; Chester Jones and Eekstein, 1955).

#### 1. *Ascidians*

On the basis of tests in three intact 26-day-old mice, Carlisle (1950) claimed to have detected gonadotrophic activity in the neural gland of ascidians. Dodd's (1955) recent evidence of more substantial nature casts doubt on the validity of this claim—yet leaves the question open, since 1 of Dodd's 10 intact 19-day-old mice receiving as much as 230 neural glands each gave a positive response. The further statement by Carlisle (1954) that mammalian pituitary and urinary gonadotrophins promote ovulation and sperm discharge in the ascidians has likewise been challenged (Dodd, 1955).

## 2. Fish

Fish have been reported to respond to gonadotrophins of piscine origin (Hasler, Meyer and Field, 1939; Rasquin, 1951; Hisaw and Albert, 1955; Hoar, 1955; Ramaswami and Sundararaj, 1956, 1957) by exhibiting out-of-season oocyte growth and spawning. It is to be noted, however, that satisfactory control experiments are often lacking. Fish respond less readily to amphibian pituitary. Induced spawning in rainbow trout (Migita, Matsomoto, Kinochita, Sasaki and Ashikawa, 1952) and catfish (Ramaswami and Sundararaj, 1957) has been claimed to follow the injection of frog pituitary. Fish appear to be almost totally insensitive to gonadotrophins of avian and mammalian origin (de Azevedo and Canale, 1938; Hasler, Meyer and Field, 1939; Hoar, 1955); however, Dodd (1955) calls attention to some instances of doubtful or limited effectiveness of mammalian gonadotrophins, especially human urinary gonadotrophins, in fish. Pickford and Atz (1957) brought together the varied and conflicting results of the multitudinous studies of reproductive physiology in fish.

## 3. Amphibians

Amphibians are notably responsive to gonadotrophins from widely differing phylogenetic sources, yet even among some of the anura the gonadotrophins show a high degree of species specificity (Creaser and Gorbman, 1939; Houssay, 1954). The effectiveness of homoplastic anuran pituitaries in inducing spermiation, ovulation, and oviposition has become a part of classical biology. By contrast, the induction of ovulation in *Rana temporaria* requires 150 times as much beef as *Rana* pituitary (Gallien, 1955a), and Houssay has shown that the South American toad, *Bufo arcuatum*, is less sensitive to rat and human hypophysis than to pituitaries of anuran origin. Strangely, the anura, although generally responsive to mammalian gonadotrophins of pituitary or placental origin, have reacted poorly—if at all—to injected brei of elasmobranch pituitaries (Creaser and Gorbman, 1939) or to those of teleosts (Creaser and Gorbman, 1939; Atz and Pickford, 1954).

Pursuing the matter of phyletic considerations further, Atz and Pickford (1954) report that the Russian workers, Stroganov and Alpatov (1951) found frogs more sensitive than fish to sturgeon pituitary; and interestingly, although their data are meager, Wills, Riley and Stubbs (1933) obtained ovulation in *Bufo americanus* and *Rana pipiens* with gar pike hypophyses. The sturgeon and gar pike, as Creaser and Gorbman (1939) point out, are closer in the phyletic scale to the amphibia than they are to the fish whose pituitaries were ineffective in amphibia.

Some exploratory studies have been made of the action of mammalian FSH and LH in amphibia. The male toad, *Bufo melanostictus*, responded to mammalian FSH and LH (Bhaduri, 1951), whereas *Bufo bufo* responded negatively to FSH (Thorborg and Hansen, 1950). Crézé (1949) reported that LH produced a positive spermiation test in *Rana esculanta*, and Atz and Pickford (1954), after testing a number of mammalian pituitary preparations, concluded that LH was 40 to 100 times more active than FSH in causing sperm release in *Rana pipiens*; the positive responses obtained with FSH were easily attributable to an LH contaminant. Wright and Hisaw (1946) studied the response of frog ovaries to purified mammalian gonadotrophins and found that, although FSH ovulated the intact frog, it was not effective in hypophysectomized females. Using the technique of Heilbrunn, Dougherty and Wilbur (1939), Wright and Hisaw applied sheep FSH to frog ovaries *in vitro* and failed to induce ovulation; but by combining FSH and LH in an appropriate ratio, ovulation was obtained. They believe that the principal function of FSH in the frog is to render the ovary sensitive to an ovulating stimulus. Oviposition was induced in the salamander, *Triturus viridescens*, by LH but not by FSH (Mayo, 1937) and Witschi (1937) elicited ovulation in the newt, *Taricha torosa*, with beef and turkey hypophyses but not with pregnant mare's serum (PMS) gonadotrophin.

The sensitivity of amphibians to human pituitary and chorionic gonadotrophins has rendered them extremely useful in clinical



assays for diagnostic purposes, especially for the early diagnosis of pregnancy. A number of species of frogs and toads are in use, mainly: (1) the male leopard frog, *Rana pipiens* (Wiltberger and Miller, 1948; Robbins and Parker, 1949; Haskins and Sherman, 1952); positive tests are also obtained with hypophysectomized frogs (Kissen, 1954), (2) the female *Xenopus laevis* (Thorborg and Hansen, 1951; Hobson, 1952), and (3) the male toad, *Bufo arenarum* (Hansel) (Galli Mainini, 1948; Allison, 1954; for review, see Houssay, 1954). The Galli Mainini test is held to be relatively more specific for the chorionic gonadotrophin in that positive responses are not obtained with urine from normal men or nonpregnant women, regardless of the presence or absence of functioning gonads. This is in line with Atz and Pickford's finding that spermiation is mainly a function of LH, the urinary output of which in normal men is very low.

#### 4. Reptiles

Few observations have been made on the interrelations of the pituitary and gonads in reptiles (Kehl and Combescot, 1955) and fewer still on the responsiveness of reptiles to heterozoic gonadotrophins. In viviparous snakes hypophysectomy led to regression of gonads and death of the embryos and premature parturition (Clausen, 1940; Bragdon, 1951). Testis impairment following hypophysectomy in male garter snakes was corrected by daily implantation of pituitary glands from the same species (Schaefer, 1933). Crude extracts of sheep pituitary promoted marked gonad stimulation in the lizard, *Uromastix* (Kehl, 1944; Kehl and Combescot, 1955), immature alligators, *Alligator mississippiensis* (Forbes, 1937), and terrapins, *Malaclemmys centrata* (Risley, 1941). In extended studies of the chameleon, *Anolis carolinensis*, Evans (1948) obtained positive results with mammalian gonadotrophins unspecified.

#### 5. Birds

Among birds males of all ages and mature females are responsive to gonadotrophins of both avian and mammalian sources (Breneman, 1936; Byerly and Burrows,

1938; Nalbandov and Card, 1946; Das and Nalbandov, 1955). These observations are based mainly on the domestic breeds, such as chickens, ducks, and turkeys (reviewed by Nalbandov, 1953a). Evidence suggesting qualitative differences between avian and mammalian gonadotrophins has been obtained by Nalbandov, Meyer and McShan (1951), Das and Nalbandov (1955), and Taber, Claytor, Knight, Gambrell, Flowers and Ayers (1958). Thus, the ovarian cortex of the sexually immature female chicken, although notably insensitive to mammalian gonadotrophins, has responded to avian pituitary extract. Taber and her associates noted significant follicle stimulation but no precocious ovulation in immature female chickens receiving long-term treatment with acetone-dried avian anterior lobe substance. In contradistinction, the medullary portion of the immature ovary, like the testes of the male bird, responded with increase in weight and androgen production at any age and to hormones of either mammalian or avian source. Following hypophysectomy of prepubertal female birds, the medullary area remained responsive to avian, but not to mammalian, gonadotrophin. Moreover, the effectiveness of mammalian gonadotrophins in maintaining the ovaries and comb of hypophysectomized laying hens was of short duration (Biswal and Nalbandov, 1952; Nalbandov, 1953a); egg-laying continued 5 to 7 days postoperatively, and comb size was sustained for 10 to 15 days. Avian hormone, alone or in combination with mammalian gonadotrophin, was effective over treatment periods lasting up to 35 days. The possibility that these results might have been influenced by the development of immune bodies was not eliminated.

Observations of interest have been made on the hypophyseal control of the rudimentary right gonad in hens (Kornfeld and Nalbandov, 1954). Compensatory hypertrophy of this structure, seen regularly in poulards, has been completely prevented by injections of estrogen, and to lesser extent by androgen. Hypophysectomy, moreover, causes regression of the enlarged right rudiment which cannot be forestalled by injections of hog or sheep gonadotrophins, nor by PMS. Whether chicken gonadotrophin-

would have the sustaining action they could be presumed to have in this situation, has apparently not been investigated.

Inasmuch as the pituitary-gonad interrelationships are complex and little understood, it is not to be expected that the administration of either isogeneric or hetero-zoic gonadotrophic complexes would elicit the normal pattern of sexual functions. As a demonstration in point, Witschi (1955) injected sparrows with the suspended powders of human, beef, or turkey hypophyses and found that human hypophyses produced good follicle growth but the oviducts were only incompletely developed; turkey and beef glands, on the contrary, promoted intense stimulation of the reproductive tract and only minor ovarian enlargement. None of these preparations produced a balanced development of the gonads and accessory sexual organs, nor did ovulation and egg-laying occur.

Prolactin is present in extracts of the hypophyses of fish, amphibians, and reptiles (Leblond and Noble, 1937) and its presence in avian pituitary was amply demonstrated by Riddle's group in the middle 'thirties. Their classic studies showed that prolactin exerts full control over the proliferative development of the crop sac in pigeons, but it also appeared to have a suppressive action on the gonads in these as well as other birds. Prolactin of mammalian origin administered to laying hens resulted in regression of ovaries, cessation of laying, and appearance of broodiness (Breneman, 1942; Nalbandov, Hochhauser and Dugas, 1945; Nalbandov, 1953a). Nalbandov expressed the opinion that broodiness is secondary to ovarian failure, with attendant reduction in estrogen secretion—a view nicely supported by the earlier finding of Godfrey and Jaap (1950) that broodiness can be quickly terminated by estrogen injections (also see chapter by Lehrman). Prolactin has also been noted to induce broodiness in coeks (Nalbandov and Card, 1946) and atrophy of the developing right gonad in poultards (Kornfeld and Nalbandov, 1954). The mechanism for the suppressive influence of prolactin on the gonads of birds is unknown, but it can be presumed to involve central nervous system centers concerned in some manner with

regulation of the anterior pituitary. Prolactin has also been noted to have a calorigenic action (Riddle, Smith, Bates, Moran and Lahr, 1936), but it has not been possible to correlate this with the induction of broodiness. Likewise, its ability to increase the body temperature of roosters 2 to 4°F. is not contributory, since broody fowl have subnormal temperatures.

#### 6. *Mammals*

Information on the effectiveness in mammals of pituitary gonadotrophins from lower orders is scanty. As would be anticipated, avian gonadotrophins are by far the most potent. Unfractionated gonadotrophic extracts of avian pituitaries exhibited both follicle-stimulating and luteinizing activity (Leonard, 1937; Witschi, 1937; Gorbman, 1941; Fraps, Fevold and Neher, 1947; Nalbandov, Meyer and McShan, 1951). The nature of the gonadal reactions induced in mammals by avian gonadotrophins are qualitatively similar to those produced by mammalian gonadotrophins (Riley and Fraps, 1942a, b; Breneman, 1945; Nalbandov and Card, 1946; Breneman and Mason, 1951).

Moderate follicular development and luteinization in rats and mice has been induced by chicken and turkey pituitaries, but full estrous development of the reproductive tracts is generally not attained. Riley and Fraps (1942a, b), using the mouse ovary assay, estimated the ratio of FSH to LH potency in bird hypophyses, and they along with Chance, Rowlands and Young (1939), Witschi (1940), and others, in fact, attempted quantitative estimations of the FSH-LH ratio in hypophyses of a variety of birds and mammals. Such precise numerical values are unfortunately of little significance, owing to the limitations of the bioassays. Nonetheless, two indications seem to emerge from these studies: the FSH-LH ratio varies greatly from one species to another, and within a given species rhythmic fluctuations have been noted. Pituitaries from such cold-blooded forms as fish, frogs, and turtles have at best shown barely positive traces of gonadotrophic activity in rats and mice (for literature, see Witschi, 1955). In fact, Adams and Granger (1941) had to

inject 100 times as much frog as mouse hypophysis to obtain minimal stimulation of the mouse ovary.

### 7. General Considerations

There are probably no generalizations that can safely be drawn from the variety of taxonomic relationships noted in regard to the gonadotrophins; but, as Zuckerman aptly contends, "knowledge can advance little if we do not generalize." Wide distribution throughout the Vertebrata is suggested for each of the gonadotrophins. The information concerning their qualitative variation that is revealed by cross-species testing is of fundamental importance to both biology and medicine. Peculiarly, there is little and perhaps no qualitative variation in the gonadotrophins from various species of teleosts (Ihering, 1937; Kazanskii, 1940; Dodd, 1955), but the number of species studied is not a fair sample of the number existent. The situation is different in the amphibia. Here qualitative variation in the gonadotrophins from different species is much in evidence. Seemingly, some anurans are capable of responding to gonadotrophins from any class of vertebrate, whereas others fail to respond even to gonadotrophins from closely related amphibian species; albeit the amphibia appear to be far more sensitive to amphibian gonadotrophins than to those from any other class of vertebrates. The reptiles, although little studied, appear to respond sluggishly to nonreptilian gonadotrophins. Birds, too, respond best to bird gonadotrophins, yet in some respects are exceedingly sensitive to those from a wide variety of mammals. Among the mammals great variations in responsiveness are revealed by every exchange of gonadotrophins between their species. The variations, however, are mainly of quantitative rather than of qualitative nature so far as is known.

The differences in species responsiveness pose difficult problems in the bioassay of the gonadotrophins. It is obvious that the potency units assigned to a gonadotrophin preparation assayed in a foreign species have no significance as to equivalent potency when the same preparation is tested in other species, even when adjustment is made so that the dose per unit of body

weight is the same. Moreover, an apparent ineffectiveness in one species may not necessarily mean that the gonadotrophin is biologically inactive; Creaser and Gorbman (1939) state that "the effectiveness of a gonadotrophic hormone in a foreign species tends to vary directly with the phylogenetic proximity of the donor and recipient species."

Recently, a marked qualitative species variation was demonstrated in connection with another pituitary hormone, somatotrophin. Preparations of swine, ovine, or bovine somatotrophin were markedly effective in rats and dogs but not in monkeys or man (for literature, see Smith, Gaebler and Long, 1955). Monkey somatotrophin, however, was effective in monkeys and also in rats (Knobil and Greep, 1956). Similarly, fish somatotrophin, which was active in fish, was inactive in mammals, whereas ox preparations were active in fish as well as in some mammals (Pickford, 1954; Wilhelm, 1955).

We have seen that the physiologic properties of a gonadotrophin are as much an expression of the sensitivity of the substrate on which the hormone acts as of the excitations of the hormone itself. This being the situation, the difficulties to be faced in retracing the evolutionary history of the gonadotrophins are indeed formidable. However, by extending lines of study that have been followed over the past 20 years, pieces of this fascinating problem may in time be fitted together. At this early departure in the quest, the dictum credited to Medawar to the effect that, "It is not the hormones which evolve but the uses to which they are put" seems grossly premature; but its value in addressing thoughtful inquiry to the matter may be considerable. Another laboratory aphorism to the effect that hormones can be tested down the phyletic scale but not in the reverse order undoubtedly contains an element of truth, but as a generalization it would seem to be fraught with much hazard. Along these same lines Witsehi (1955), noting the spread in effectiveness of mammalian LH—at least to the amphibia—remarked, "One definite conclusion derives clearly from the now available evidence; namely, that induction of ovulation is a much more general and more ancient func-

tion of LH than is its role in the formation of corpora lutea."

B. AGE, SEX, GONADEXCTOMY, AND REPRODUCTIVE RHYTHMS IN RELATION TO PITUITARY GONADOTROPHINS

1. *Fetal Gonadotrophins*

Experiments cited by Smith (1939) revealed no demonstrable gonadotrophic activity in the pituitary of fetuses except in the hog and horse. The amount of pooled tissue available for such tests with other species was often so small as to make the negative findings inconclusive. The original work of Smith and Dortzbach (1929) on the pig fetus is still the most complete. Gonadotrophin was detected in the late fetal stages.

Much experimental evidence bearing on the relation of the hypophysis to the development of the fetal gonads has been obtained over the past several years, principally from the laboratories of Wells in Minnesota and Jost in Paris. These studies are admirably summarized by Jost (1953, 1955, 1956a) and Wells (1956). Each group developed techniques for intra-uterine ablation of fetal endocrine glands, including the hypophysis; the latter being accomplished, in effect, by decapitation. Decapitation of rat fetuses on day 18 did not lead to abnormalities in the differentiation and development of either the gonads or the accessory sexual structures. By contrast, removal of the testes on day 18 led to deficiencies in the development of the prostate and coagulation glands, and a failure of the Müllerian ducts to regress normally. This, according to Wells, is a deficit in maleness correctable by testosterone and is not to be construed as a feminizing influence. Substitution of testosterone from the time of fetal castration prevented all the impairments of development except the regression of the Müllerian ducts. It would seem that the fetal testis exerts an influence over development of the male accessory structures and that this action is independent of any stimulus from the hypophysis.

The effects of fetal decapitation in rabbits as studied by Jost differ from those in the rat in one important respect. Male fetuses decapitated on the 19th, 20th, or 21st day

of gestation were born at term in a semi-feminized state as regards the accessory ducts and external genitalia. These changes did not occur when decapitation was performed after the 23rd day nor when the headless fetuses were injected with gonadotrophin. By way of explanation, days 22 and 23 were held to be a determinative phase during which the prospective development of the sexual ducts is established by the fetal testis acting in response to the fetal pituitary. Cytologic examination of the fetal hypophyses during this period revealed the transient presence of McManus-positive cells on the 22nd and 23rd days, which Jost believes may signal a transitory production of gonadotrophins. That the fetal rabbit pituitary actually secretes gonadotrophin on days 22 to 24 would require more positive documentation than is presently available. There are considerations that urge caution. The female rabbit ovary is known to be refractory, at least to exogenous gonadotrophin, throughout the entire infantile period (Hertz and Hisaw, 1934), a finding common to many infant mammals. The fact that McManus-positive material appeared in the pituitary cells is suggestive, but by no means conclusive, evidence of secretion of gonadotrophins. There is also the possibility that maternal gonadotrophins are available to the fetus, but the evidence is controversial (Knobil and Briggs, 1955; Jost, 1956b). It seems clear that any function served the fetus by maternal gonadotrophins may be of minor significance, inasmuch as the maternal pituitary gland has been removed quite early in gestation in several mammals, including the rhesus monkey (Smith, 1954, 1955), without impairment to the development of the fetal male or female reproductive systems. Moreover, in man and horse the available evidence suggests that the pituitary gland is extremely weak in gonadotrophic activity throughout most of the gestation period, including the puerperium.

2. *Age and Sex*

Breneman and Mason (1951) and Breneman (1945, 1955) made detailed studies of the gonadotrophic potency of cockerel and pullet pituitaries (using the chick testis assay) during the initial 3 to 4 months of life

and collated these data with growth of the gonads. For 3 weeks postnatally the total glandular potency remained very low in both sexes. Thereafter the cockerel pituitary gained steadily in both total and unit potency, reaching a plateau at about 90 days. The unit potency increased approximately five times and was accompanied by an approximate parallel increase in the weight of the testes of the donor birds. Pullets over 20 days of age showed a similar rise in potency plus a sharp upturn in both unit and total potency coincident with the burst of ovarian enlargement between the 115th and 125th day of life. It is precisely at this point that female chickens were found to become overtly responsive to mammalian gonadotrophins (Das and Nalbandov, 1955; Breneman, 1955). Among adult fowl the pituitaries of nonlaying hens, as tested by the mouse uterine weight method, are about twice as potent as those of laying hens (Riley and Fraps, 1942b). The pituitaries of mature male chickens are markedly more potent than those of females of comparable age; although the male glands are heavier, the difference in potency cannot be accounted for on this basis alone (Riley and Fraps, 1942a; Phillips, 1943; Breneman and Mason, 1951). The pituitary of the male pheasant is likewise more potent than that of the hen pheasant (Greeley and Meyer, 1953).

Among the most systematic studies of gonadotrophic potency in relation to postnatal age and sex are the early ones in rats by Clark (1935a), McQueen-Williams (1935), and Stein (1935). Gonadotrophin appears in assayable quantity around the end of the 2nd week of life, when the gonads are first becoming responsive to gonadotrophic stimulation. They found a spike in the age-potency curve for the female gland at the 3rd postnatal week, which was not exceeded even during sexual maturity.

Pituitaries of adult male rats are markedly more potent in gonadotrophic complex than those of females of comparable age. Clark's data show that the relative superior potency of the male gland is not attained until some months after puberty. Hoogstra and Paesi (1955) examined the FSH and LH content of the pituitaries of intact immature and adult male and female rats and,

in agreement with Clark, found the total FSH content of the immature female pituitary greater than that of the adult female or immature male, but not as great as that of the adult male. In terms of FSH per unit of glandular tissue, adult male pituitary appeared to be about five times as potent as the pituitary from adult females of comparable age. The LH content of the pituitaries from immature males and females was low and approximately equal; in adults, the amount had increased considerably and was greater in the males.

Hollandbeck, Baker, Norton and Nalbandov (1956) estimated the potency of sow pituitaries from birth through 1330 days of age, using the chick testis assay. The results were expressed in terms of the weight of the anterior lobe and correlated with age and body weight. The unit potency decreased linearly with age, whereas total potency showed a linear increase, because, of course, the weight of the pituitary increased with age. The amount of hormone available per unit of body weight was very high at birth and declined through the prepubertal period to a low level which remained nearly constant from puberty onward. This steady drop in available hormone per unit of body weight through the prepubertal period is not in accord with the general assumption that an increase in titer of circulating gonadotrophin precedes puberty. Such data do not rule out a likely increase in secretion of gonadotrophin nor, as the authors have suggested, the possibility that an imbalance may have occurred in the ratio at which the gonadotrophic factors, FSH and LH, were secreted. The high potency during infancy was thought to be due to the presence of mainly FSH. The initiation of cyclic ovarian activity at puberty was thought to signify augmented secretion of LH, yielding a more functionally balanced FSH-LH ratio. Similarly, from evidence based on the urinary excretion of FSH and LH in the human female, Brown (1958) showed that the prepubertal period may be characterized by a rising level of LH.

Among the primates informative data relating to the ratio and content of FSH and LH in the hypophysis in relation to sex and age have been obtained only for man. Babo and associates (1953a-d) studied the FSH

and LH content of the human hypophysis in infancy, childhood, maturity, and old age. The glands were obtained from persons dying without prolonged terminal illness and were obtained within 1 to 4 hours after death. The anterior lobes were dissected free, weighed, and kept frozen until time of use. The glands from a given age group were homogenized, pooled, and administered to hypophysectomized immature male and female rats in total doses of homogenate corresponding to 1, 3, 10, and 30 mg. wet weight of anterior lobe tissue; FSH was indicated by follicle growth or stimulation of seminiferous tubules, LH by repair of the Leydig cells. In essential confirmation of earlier studies, they found that the hypophysis of the human infant has no detectable FSH or LH activity. By childhood (4 years) both hormones were present in minimal quantity. The hypophyses from women of reproductive age and mature men were notably potent in both FSH and LH; they were essentially equipotent per unit of tissue for each hormone, but the female gland being heavier had a total content greater than that of the male. Using different end points and methods of collection, Witschi (1940), Witschi and Riley (1940), and Witschi (1952) reported a sex difference—they list in round figures the total FSH unitage in hypophyses of humans dying after prolonged illness as 50 R.U. for mature males and 10 R.U. for nonpregnant mature females. In keeping with the observations of Henderson and Rowlands (1938), Witschi (1940) and Witschi and Riley (1940) found the human hypophysis to contain not more than traces of LH as determined by the Weaver finch or rat test. However, the validity of this claim of the Iowa group has been challenged by the more meaningful positive findings of Balm, Lorenz, Bennett and Albert (1953a, c) that the adult human hypophysis is moderately rich in LH.

Burt and Velardo (1954) studied individual hypophyses from 18 patients, 9 males and 9 females, ranging in age from 19 to 82 years. Most of these patients had died after prolonged illness and some had received hormone therapy. The glands were assayed by injecting 7.5 mg. of fresh gland homogenate into hypophysectomized male and female rats. Of these human hypophy-

ses, 6 produced reasonably good follicle growth and formation of corpora lutea, 6 produced only minimal follicle stimulation, and 6 exhibited no gonadotrophic activity. In this small series the authors were unable to detect any correlation of pituitary potency with sex or age. It is interesting, too, that they were unable to predict the gonadotrophic potency in individual glands on the basis of a sampling of the relative percentage of cell types present.

There is general agreement that the concentration of gonadotrophin in the hypophysis tends to increase in old age in many animals, but it is only in women that increased release is thoroughly documented, this being demonstrated by the increase in the blood and urinary titer of gonadotrophin at the time of the menopause. Witschi and Riley (1940) and Witschi (1956) reported that the total FSH content of the hypophyses of postmenopausal women is 4- to 5-fold greater than that of women of reproductive age. The hypophyses of old men show great variability, with some glands reaching the high potency of those of postmenopausal women and castrated men. Older men show also a fairly consistent small increase in urinary gonadotrophin beginning at about 60 years of age (Pedersen-Bjergaard and Tonnesen, 1948).

### 3. *Gonadectomy*

An increase in the gonad-stimulating potency of the anterior hypophysis following gonadectomy or total loss of gonadal secretory functions through any means other than primary pituitary failure has been found to be an almost invariable occurrence especially in the warm-blooded vertebrates. An early report of a negative finding in castrated pigeons (Schooley, 1937) needs confirmation, inasmuch as Breneman (1945) found that the capon pituitary is distinctly more potent than that of cockerels of the same age. Although the gonadotrophin content in sheep pituitary is high, it is at its peak during the time of reproductive quiescence (Kammilade, Welsb, Nalbandov and Norton, 1952) and increases in the ewe following spaying (Warwick, 1946).

An objective of recent studies has been to elucidate the effects of gonadectomy on

the separate follicle-stimulating and luteinizing activities of the pars distalis.

Bahn, Lorenz, Bennett and Albert (1953b) found a sharp increase in the FSH content of the human hypophysis at the time of the menopause, with no coincident increase in LH. The ratio of FSH to LH was found to be 1:1 in the pituitaries of women of reproductive age and 3:1 in those from women past the menopause. The failure of LH to increase under these conditions in man is at variance with the observation by McArthur, Ingersoll and Worcester (1958) that appreciably more LH is excreted in the urine after the menopause than during the reproductive years.

In recent years the Dutch workers, Paesi, de Jongh, Gaarenstroom, and Hoogstra introduced modifications in their procedure for studying the gonadotrophic activity of rat pituitaries, which provide in their views an estimate of the relative amounts of FSH and LH (for methods see Hoogstra and Paesi, 1955, 1957). Paesi, de Jongh, Hoogstra and Engelbregt (1955) reported that gonadectomy produced within 3 months a 5-fold increase in the FSH content of the pituitaries of females, and no conspicuous increase in males; LH increased following gonadectomy in each sex, but more so in males than in females. Their finding that gonadectomy tended to diminish the sex difference in pituitary gonadotrophic content in rats is in keeping with the experience of others.

#### 4. Reproductive Rhythms

*a. Cyclic changes.* In those species in which the reproductive activity is closely tied-in with seasonal alterations in the environment, the expectation is that the peaks in pituitary potency would correspond with periods of heightened breeding activity. The few observations available suggest that with certain exceptions this is true.

Valuable preliminary data based on a year-round collection of adult pheasant pituitary has been summarized by Greeley and Meyer (1953). The dried glands were pooled by months or pairs of months and tested in day-old chicks for testis-stimulating potency. The potency of the glands was at a minimum in July when the testes of the donor birds were undergoing rapid regres-

sion. Before settling to winter level pituitary potency showed a small increase, while the testes were in what several workers have termed a "refractory state" (see Marshall, 1955). The major upsurge in pituitary gonadotrophin, correlating well with weight of donor testes, occurred in January, February, and March, and reached its maximum in April. The close parallel of hypophyseal potency and testis development throughout the annual cycle is noteworthy. It indicates that pituitary gonadotrophin content reflected accurately the rate of gonadotrophin release. Benoit's early studies showed that the duck pituitary is weakest in the off-breeding season and gathers gonadotrophic potency as added illumination brings the animals into sexual competence; also Riley and Fraps (1942b) found a lesser potency in laying than in nonlaying hens.

Some information has been obtained from mammals. The pituitary of the ground squirrel has a much reduced gonadotrophic potency during hibernation (Wells, 1935). A peculiar situation was found to exist with respect to the cottontail rabbit at the time of the breeding season. The pituitary of the male showed an increase in gonadotrophic content, whereas that of the female did not (Elder and Finerty, 1943). Assay of mule deer pituitaries (Grieser and Browman, 1956) has indicated that potency in yearling does is lowest in winter months, gradually increases as spring progresses, and reaches a peak by late fall.

In recent years pituitary gonadotrophic potency has been studied throughout the estrous cycle in the cow, sow, and ewe. The gonadotrophic potency of the cow pituitary is at its lowest point during estrus (Paredis, 1950). In like manner, Robinson and Nalbandov (1951) reported that the gonadotrophin content of sow pituitaries collected during estrus was approximately half that of pituitaries taken at midcycle. The potency remained low in glands taken through the first 8 days of the cycle and then climbed sharply.

Reports on cyclic variations in the gonadotrophic potency of the ewe pituitary are at variance. According to Robinson (1951), potency is at its peak during estrus; Warwick (1946), however, found no difference between glands collected during the breed-

ing season and those obtained in the non-breeding season. Kammlade, Welsh, Nalbandov and Norton (1952), using the same assay as Warwick—the chick testis—found the potency highest during anestrus and lowest during estrus. Although the reproductive tract of the anestrus ewe was found to be atrophic, the ovaries contained a few sizeable follicles (Hammond, 1945; Nalbandov, 1953a, b) and ovulation was induced by exogenous gonadotrophins. Granting that LH is a requisite for the secretion of estrogen as well as for ovulation, Kammlade, Welsh, Nalbandov and Norton (1952) and Nalbandov (1953b) speculated that anestrus in the ewe may perhaps be attributed to an imbalance of the gonadotrophins characterized by increased pituitary FSH potency and a deficiency in circulating LH. They surmised that the follicular development was brought about by the action of virtually “pure” endogenous FSH. In accord with this view Dutt (1953) and Robinson (1952, 1954) reported that ovulation, followed in some instances by pregnancy (Robinson, 1950), can be induced in the anestrus ewe by the administration of progesterone, thereby suggesting that LH is “stored.” Progesterone, as noted elsewhere, can be used to induce or hasten ovulation in hens, estrous rabbits, the persistent-estrous rat, and in monkeys during the anovulatory summer months. According to current opinion, these effects are attributable to excitation of neurohumoral mechanisms which promote the release of LH. Missing for the purpose of the present consideration is knowledge of whether or not the pituitary of the anestrus ewe contains LH. Unfortunately the methods used in studying the ewe pituitary have not been informative in regard to the separate gonadotrophic activities.

Especially noteworthy are the data of Simpson, van Wagenen and Carter (1956) concerning the fluctuation in pituitary gonadotrophic potency in adult female monkeys killed at different stages in the menstrual cycle. The low titer of FSH (in unit and total potency) at the beginning of the cycle quadrupled near the end of the follicular phase and decreased during the luteal phase. The unit and total potency of LH was highest on days 9 to 11. The FSH to LH ratio

was roughly 1:3 at the beginning and end of the cycle and 1:10 through the preovulatory and ovulatory stages. This is mainly because the LH increased relatively much more during that time than did FSH. At the time of greatest concentration, the minimal effective dose for both FSH and LH effects was 1/10 that of pooled sheep pituitary powder. The two hormones were, however, present in the same relative proportions as in sheep pituitaries.

*b. Pregnancy.* Marked differences exist in the gonadotrophic functions of the hypophysis during pregnancy. In a number of animals, of which the monkey, guinea pig, rat, and mouse are examples, the gonadotrophic functions of the pituitary are assumed by the placenta to the extent that the hypophysis can be ablated without interrupting pregnancy (for review see Smith, 1954). There are authenticated instances in which the ovaries involute especially during the later stages of gestation. Contrariwise, in many animals growth of ovarian follicles continues throughout gestation and, in some, heat ensues immediately following parturition (for review see Williams, Garrius, Norton and Nalbandov, 1956, and chapter by Young on the mammalian ovary). There are many reports of mating and of spontaneous or artificially induced ovulation during pregnancy. It is, therefore, not unexpected that marked variation between species has been noted with respect to the gonadotrophic activity of the hypophysis during pregnancy; it has been reported to increase, decrease, or to show little or no change (reviewed by Cowie and Folley, 1955). Within species, the results have not always been consistent; such discrepancies are probably related to the different procedures that have been used for collecting, storing, and assaying the glands. In a notable example, the pituitaries of pregnant cattle were observed to show a steady increase in gonadotrophic content over those of non-pregnant animals (Bates, Riddle and Lahr, 1935), but in a later study (Nalbandov and Casida, 1940) the potency was found to decline steadily throughout pregnancy. Similarly, Robinson and Nalbandov (1951) found that the gonadotrophic potency of the pregnant sow decreases throughout gesta-



tion. There is agreement that in man the pituitary gonadotrophic potency falls during the second month of gestation and remains barely detectable until a few days postpartum (Bruner, 1951). It has been assumed that in man placental gonadotrophin (HCG) is an important sustaining factor. The pregnant mare, however, also has a rich extrapituitary supply of gonadotrophin, yet shows no decline in pituitary gonadotrophic potency (Hellbaum, 1935). Some have tried to relate the instances of reduced pituitary potency during gestation to high titers of circulating estrogens, but the inconsistencies are again extreme. (For reviews of this controversial literature see Burrows, 1949; Ladman and Runner, 1953; Cowie and Folley, 1955). Recent reports have been few. Ladman and Runner (1953) in a detailed study of the pituitaries of pregnant mice found changes suggestive of a cyclic fluctuation in potency during gestation. In breeding mule deer the peak potency occurred in the fall and was followed by a sharp decline which persisted during most of gestation with a slow rise occurring near term (May or June).

#### C. EFFECT OF DIETARY RESTRICTIONS ON PITUITARY GONADOTROPHIC POTENCY AND FUNCTION

##### 1. Underfeeding

There is a large body of experimental data showing that poor nutritional status whether caused by reduced food intake or impaired assimilation has a deleterious influence on reproductive functions (for comprehensive review of nutrition-endocrine relationships, see Ershoff, 1952 and chapter by Leatham). It has long been known that in the common laboratory animals controlled inanition and starvation produce atrophy of the gonads and accessory sex structures and varying degrees of infertility. Similarly, loss of reproductive functions have been observed in human populations during periods of restricted food intake. That the level of circulating gonadotrophins is reduced under these conditions is indicated by involution of the gonads and also, as shown in rats, by the fact that the gonads remain sensitive to administered gonadotrophins (Werner, 1939), the excep-

tion being that stimulation of the testis requires an adequate replacement of vitamin E. Since it has been found that the pituitary gonadotrophin content remains at normal (Maddock and Heller, 1947) or somewhat greater than normal levels (Meites and Reed, 1949; Rinaldini, 1949) during chronic caloric restriction, it would seem that the primary defect in pituitary function is failure, not so much in the *synthesis*, as the *release* of hypophyseal gonadotrophins. Maddock and Heller (1947) also emphasized the dichotomy that is evoked through inanition between pituitary gonadotrophic content (normal) and gonadotrophic function (low). This involves the important assumption that the gonadal tissues have not lost their sensitivity to gonadotrophic stimuli as a result of undernourishment. That exogenous gonadotrophins are effective under these circumstances does not exclude the possibility of a relative reduction in substrate sensitivity. It is of interest that castration type cells do not develop in the pars distalis during inanition despite the severe reduction in gonadal functions. That pituitary potency does not increase *pari passu* with inhibition of release of gonadotrophin is an indication that production of gonadotrophins is also impaired during these periods of restricted food intake.

*a. Related observations on inanition and sex function in man.* Many times in the history of man he has been exposed to malnutrition of considerable duration. Currently, two-thirds of the world's population is undernourished and many authors incline to the view that actual starvation will become more widespread in the future. Although the associated endocrine disturbances have been given little attention in these conditions, there is convincing evidence that they constitute an extremely important part of the syndrome. Among the clinical manifestations of chronic underfeeding, there are generally symptoms attributable to dysfunction of the thyroid, adrenals, gonads, and pituitary. The few laboratory experiments in human starvation have not made full use of the various indices of endocrine function. Moreover, there is much doubt that studies of the nature of the Minnesota Experiment (Keys, Brozce, Henschel, Michelson and Taylor, 1950) conducted under situations

of personal security and absence of other than hunger-induced anxieties are to be compared with either mass starvation or the exigencies of war deprivations.

That many of the findings in experimental animals are applicable to man is suggested by the high incidence of impaired reproductive functions in women during states of chronic malnutrition (Keys, 1946; Keys, Broeze, Henschel, Michelson and Taylor, 1950; Samuels, 1948; Gillman and Gillman, 1951; Zubirán and Gómez-Mont, 1953).

One of the better documented studies of the endocrine aspects of chronic malnutrition in man is being made in Mexico by Zubirán and Gómez-Mont. In 1953 they reported on 529 adult subjects, all with a long history of undernourishment, and 195 autopsies of subjects suffering the effects of starvation. Estrogenic activity as measured by estrogen excretion and by vaginal smears was found to be absent in a high percentage of cases in women of menstrual age. The number in which menstruation had ceased was equally high. These evidences of the severity of the disturbances of ovarian function were fully borne out by examination of ovaries at autopsy after prolonged starvation. The ovaries were extremely small and atrophic and not infrequently absent.

It is pertinent also that Zubirán and Gómez-Mont, contrary to the work of Biskind (1946) and of Lloyd and Williams (1948), found no evidence of hyperestrogenism in patients with impaired liver function. Their data show clearly that the excretion of urinary estrogen is low in a high percentage of cases during chronic malnutrition, irrespective of the presence of cirrhosis or the extent of liver impairment. During recovery, however, these workers often found a transitory increase in estrogen excretion sometimes of great magnitude. In males, such increases usually preceded the appearance of gynecomastia which generally outlasted the period of heightened estrogen titers. Zubirán and Gómez-Mont believe that unawareness of the effect of refeeding on estrogen production may furnish an explanation for most of the reported cases of hyperestrogenism which have been attributed to liver damage and the failure to inactivate estrogen.

## 2. Vitamin Deficiencies

Gonadal dysfunctions of varying severity are also noted in animals fed diets deficient in one or another of the various B vitamins (*thiamine*, Drill and Burrill, 1944; *pantothenic acid*, Figue and Allen, 1942; *riboflavin*, Warkany and Schraffenberger, 1944; *pyridoxine*, Emerson and Evans, 1940, Nelson and Evans, 1951; *biotin*, Okey, Pencharz and Lepkovsky, 1950; and  $B_{12}$ , Hartman, Dryden and Cary, 1949; the references cited are *inter alia*). In each instance the data suggest an impairment of the secretion of gonadotrophins and there is considerable agreement that this, in turn, is attributable to the accompanying inanition rather than to any specific vitamin deficiency *per se*. With respect to pituitary hormone content, Wooten, Nelson, Simpson and Evans, (1955) reported finding a striking increase in gonadotrophic potency in vitamin  $B_{12}$ -deficient rats. In terms of the separate gonadotrophins they found a 3- to 4-fold increase in FSH and little or no change in LH or LTH. With respect to vitamin E, it has been established that in rats and guinea pigs a deficiency of this factor injures the seminiferous tubules and causes resorption of embryos. Inconsistent findings have been reported with respect to the pituitary gonadotrophic potency in vitamin E-deficient rats: an increase was noted by Pan, van Dyke, Kaunitz and Slancz (1949), and no change by Biddulph and Meyer (1941). The defects produced by absence of vitamin E are in the gonads and are not correctable by administration of gonadotrophin (Mason, 1933; Drummond, Noble and Wright, 1939; Ershoff, 1943). Despite extensive study, the effect of vitamin A deficiency on pituitary gonadotrophin content has not yet been clearly defined (for a review of literature see Ershoff, 1952).

## 3. Deficiency in Intake of Protein or of Specific Amino Acids

The effect of protein deprivation on hypophysal functions has been lately re-examined by Leatham (1958) and is discussed in his chapter. He has emphasized the importance of a labile body protein reserve and the biologic value of

dietary protein for the maintenance of normal reproductive performance and for recovery from the impairments induced by severe protein restriction. Female rats fed a diet containing less than 6 per cent protein showed marked atrophy of the reproductive organs, whereas male rats fed protein-free diets showed little impairment of spermatogenesis or loss of testis weight although the accessory sex organs were reduced by 50 per cent. Considerable data are available indicating that protein restriction impairs the secretion of gonadotrophin in female rats (Samuels, 1950). Less attention has been paid to pituitary hormone content. Leatham (1958) noted a reduction in total gonadotrophic potency in male rats fed a protein-free diet, whereas Srebnik and Nelson (1957) obtained an approximate 2-fold increase in FSH content with no change in LH. They found also that protein restriction did not interfere with increases in production and release of FSH and LH following ovariectomy.

Rabbits are surprisingly resistant to protein depletion. Friedman and Friedman (1940) found that female rabbits maintained on protein-free diets continued to manifest estrus and their capacity for restitution of the gonadotrophic hormone potency of the anterior pituitary following ovulation was unimpaired. The relationship of deficiencies in specific amino acids to pituitary gonadotrophic functions have not been satisfactorily elucidated. The conflicting evidence is reviewed by Ershoff (1952).

#### IV. Gonadal-Hypophyseal Interrelationships

The dependence of the gonads on the secretions of the anterior lobe of the pituitary has been clearly demonstrated in the mammals and, although less well documented, exists for all vertebrates, to a greater or lesser degree. This dependence has brought about the consideration of the adenohypophysis as a "master gland," but this designation connotes a degree of independent control over the endocrine function of the gonads and the other so-called target organs which is not strictly in accord with the facts. There is strong evidence that each of the target organs is an important factor

in the determination of the functional level of the hypophysis. The gonads and the pituitary play upon each other toward the achievement of a balance of function, harmonious with the fulfillment of the precreative functions of the organism. This reciprocal relationship, long known to endocrinologists, has been referred to as "negative feed-back" or "push-pull." Variations in these interrelationships coincide with the changing epochs of the life of the individual animal. In the mammals the main phases are immaturity, puberty, maturity, and senescence. During each there are subtleties of interplay between hypophyseal and gonadal influences. Mention should be made of the fact that these interactions of the hypophysis and gonads are in large measure dependent on the permissive conditioning of the internal environment by other glands, but especially by the thyroid and adrenals (see chapters by Albert and by Young on the ovary).

##### A. IMMATURITY

Following birth there is a period during which the ovaries are quite unresponsive to administered gonadotrophins. During this period, extending to about 15 days of age in rats, follicles are present which are indistinguishable morphologically from others which respond readily at an older age. Although the reason for this ovarian insensitiveness to extraneous gonadotrophins during infancy is unknown, Hisaw and Astwood (1942) suggested that there must be physiologic differences between follicles that are morphologically similar. Zuckerman (1952), on the contrary, believes that the follicles become responsive only after a theca interna has been fully differentiated. Along this same line Hisaw (1947) speculated that the secretion of estrogen by the theca is a necessary preliminary to the attainment of follicular sensitivity to gonadotrophins. He suggested that estrogen acts on the immature follicle in the manner of an organizer, thus rendering the granulosa competent to respond to FSH. Although there is considerable evidence for a direct action of estrogen on ovarian follicles (discussed more fully on page 268 and in the chapter by Young on the ovary) the assump-

tion that initiation of ovarian secretion precedes the capacity to respond morphologically to gonadotrophins has not yet been substantiated by experimental evidence.

Under normal circumstances, it is possible that gonadal maturation is brought about by the elaboration of gradually increasing amounts of pituitary gonadotrophins, primarily FSH, or by a gradual increase in competence of the gonads to respond to gonadotrophins already present even in immaturity. It is tempting to surmise that the gonads of the immature animal elaborate sufficient steroid to suppress the development of gonadotrophic functions. There is some evidence that this may be true in females but the situation is less clear in males. Gonadectomy at birth, as Clark (1935b) has shown, leads quickly to an increase in pituitary gonadotrophic potency in females but not in males. The mechanism which sustains immaturity may therefore not be the same in the two sexes.

Despite the apparent refractoriness of infantile ovaries to gonadotrophins of exogenous origin, they respond readily to excessive endogenous gonadotrophins. Thus, ovaries of newborn rats transplanted to the anterior ocular chambers of spayed adult rats respond quickly as shown by an increase in size, follicle maturation, and ovulation, and by the re-establishment of cyclic estrus in the host (Dunham, Watts and Adair, 1941). Ovaries which would not normally mature until 45 to 70 days of age were functional as grafts at 10 to 20 days of age. This hastening of maturity was not influenced by the period between spaying and grafting, *i.e.*, grafting at the time of spaying was just as effective as grafting at a later time.

It is pertinent that considerable advancement of sexual maturation was seen by Greep and Chester Jones (1950b) in rats in which the ovaries were removed on the 26th day of life and grafted into the neck. These young animals exhibited opening of the vaginal membrane and vaginal estrus within 5 to 10 days. In this strain of rats vaginal patency normally appears at about 55 days of age. It was assumed that in the interval before circulation was re-established in the graft the pituitary had increased its secretion of gonadotrophins as it is known to do when gonadal secretions are eliminated or

rendered ineffective. The revascularized ovaries responded precociously to this heightened pituitary stimulation. Although Mandl and Zuckerman (1951) were not able to confirm these findings, it is to be noted that the vaginas in their control rats opened at a mean age of 37 days, which allows small latitude for demonstrating a hastening of vaginal opening by this procedure. Many workers have seen precocious vaginal estrus in immature female parabionts following gonadectomy of their partners (for review see Finerty, 1952) and an increase in blood level of FSH has been detected in rats 7 days after spaying (Cozens and Nelson, 1958). It is evident, therefore, that the pituitaries and gonads are in delicate hormonal balance through the period of immaturity, any disruption of which leads quickly to alteration of the endocrine state.

#### B. PUBERTY AND MATURITY

Puberty is characterized by complex interactions between the gonadotrophins and the sex steroids. These become particularly evident in the cyclical episodes in the life of the mature female (Young and Yerkes, 1943). Experiments which have attempted to unravel these basic pituitary-gonadal interrelationships and the mechanisms responsible for cyclic gonadal functions have involved, as one method of attack, the injection of steroid hormones into intact pubertal or adult female mammals.

The influence of the steroid hormones, especially that of the gonadal hormones and their congeners, on the pituitary has been extensively studied. The great variety of experimental procedures employed in these studies has not negated their importance, but it has made comparison of results for a given steroid or between different steroids more difficult and of less validity than might otherwise have been the case. Van Dyke (1939) and Burrows (1949) have provided comprehensive reviews of these data. It will serve the purpose here to examine recent studies wherein a more discriminatory methodology has been employed. These will illustrate the major approaches and recapitulate earlier findings.

When any steroid, natural or synthetic, endogenous or exogenous, acts on the pituitary, the alternatives are that its function

will be increased, decreased, or left unaffected. For practical reasons alone it has been disappointing that the results achieved have been predominantly those of inhibition. Consequently the physician is today fairly well armed with ways of slowing, but not of arousing, pituitary gonadotrophic activities.

### C. EFFECTS OF ESTROGENS ON FOLLICLE-STIMULATING HORMONE SECRETION

The result of the administration of steroids to animals depends on not only the state of the animal, but also the dose of the hormone and duration of the treatment. Among the known inhibitors of pituitary gonadotrophin secretion, the estrogens are the most effective. There is complete agreement that estrogen in moderate to high dosage inhibits FSH synthesis and liberation. No clear qualitative differences have been encountered in the effect of a variety of natural and synthetic estrogenic steroids in this regard. Quantitative differences in the capacity of the many available estrogens to suppress FSH secretion, however, are readily demonstrable and are directly referable to the estrogenicity of the steroid. Present evidence suggests that, although physiologically equivalent dosages of a number of estrogenic substances do not produce precisely comparable effects on the pituitary, a close correspondence exists between the ability of an estrogen to induce vaginal estrus and its inhibitory action on the pituitary.

The influence of relatively large amounts of estrogens on the secretion of gonadotrophins is of interest, but particularly helpful in resolving the problems of normal physiology are those experiments in which low dosages of estrogens, at or near the naturally occurring levels, have been given. Here, however, there is not agreement with respect to the meaning of the results. It has often been claimed that maturity may be achieved by pituitary function independent of estrogen secretion. In the development of a broader concept, Heller and his co-workers were the first to take the position that amounts of estrogen falling within physiologic limits have no suppressive action on pituitary potency in rats nor on the secretion of gonadotrophins as measured by urinary

excretion (of FSH) in women. Thus Lauson, Heller and Sevringhaus (1938) reported that ovarian development and sexual maturation in rats were not altered by chronic treatment with what they considered to be physiologic quantities of estrogen, nor did the pituitaries exhibit any significant decrease in gonadotrophin content. Heller and Heller (1939) and Heller, Heller and Sevringhaus (1942) found that amounts of estrogen which inhibited ovarian compensatory hypertrophy in rats following unilateral castration did not decrease pituitary potency; and in women doses of estrogen, adequate to control clinical symptoms at the menopause, did not diminish the excretion of gonadotrophin. Heller, Chandler and Myers (1944) also reported that whereas physiologic doses of estradiol failed to prevent the typical rise in the titer of urinary gonadotrophin following ovariectomy in women, larger doses were completely effective. This series of papers by Heller and his associates has long been puzzling in the interpretation of pituitary-gonadal relationships. It is a weak point in their evidence that they used uterine stimulation in recipient immature intact rats as the end point for the assay of pituitary gonadotrophin potency. It is doubtful if this procedure is sufficiently reliable for the establishment of this important concept. It is to be noted that in the domestic fowl Breneman (1955) likewise has observed no suppressive effects on gonadal maturation using doses of estrogen that are within the upper limits of normal blood estrogen levels.

Heller's observations have been contradicted by later observations based on more critical assay procedures. Biddulph, Meyer and Gumbreck (1940) suggested that gonadotrophic functions in rats are inhibited by doses of estrogen well below the threshold dose for the estrous reaction of the vagina. Of greatest interest and pertinence, Byrnes and Meyer (1951a) found that the minimal amount of estradiol or estrone required to stimulate the uterus in the spayed member of spayed-intact parabionts was 3 to 4 times that needed to inhibit the pituitary of the same animal as judged by the ovaries of the adjoined twin. In an extension of this study Byrnes and Meyer (1951b) administered estradiol in closely graded doses to single immature (30-day-old) and

adolescent (55-day-old) rats, intact and spayed, for 10 days. The amounts given were estimated to be within physiologic limits. In the immature animals more estrogen was required to produce positive stimulation of the uterus than to inhibit the pituitary; the evidence for a similar differential in the adolescent group was equivocal. Greep and Chester Jones (1950b), using adolescent rats, observed that a dose of estradiol benzoate which would inhibit ovarian development in intact rats was adequate for uterine maintenance in coetaneous castrates. Byrnes and Meyer (1951b) observed further that the quantity of estrogen required to inhibit the pituitary increased from the immature to the adolescent rats by a factor of 2.77. Although dilution of hormone is involved because of the greater size of the older animals, this did not seem to invalidate the conclusion that the anterior pituitary becomes increasingly less sensitive to the suppressing action of estrogen as sexual maturation progresses.

These data indicate that FSH secretion and estrogen bear a reciprocal relationship and emphasize that FSH secretion is not a pituitary property *sui generis* but depends on the concomitant secretion of steroids. This idea has an important bearing on how a state of sexual maturity is attained. If we consider that the evidence is in favor of a prepubertal gonad-pituitary interaction, we must assume that the immature gonad has some capacity to secrete estrogen. In an unconfirmed report, Zephiroff, Drosdovsky and Dobrovolskaya-Zavadsкая (1940) have claimed that immature rat ovaries have a significant estrogen content. Byrnes and Meyer (1951b) have postulated that refractoriness of the adolescent rat pituitary to estrogen permits higher levels of FSH secretion and thus allows the attainment of puberty. It seems clear that future progress in this area will depend on the development of satisfactory methods for measuring the blood level of pituitary and ovarian hormones. Until such information is available it would be helpful merely to have some of the present evidence confirmed. If, for instance, it were firmly established that the pituitary of the immature animal is more sensitive to estrogen than is the uterus, this

would form an excellent starting point for future investigations.

Exceptionally valuable information concerning the effect of administered steroids on pituitary function has been gained from studies of parabiotic rats. The preparation which has been most commonly employed has consisted of immature rats, one of which is castrated at the time of or following the surgical union. Given no treatment, as in control pairs, the castrated animal's pituitary steps up the output of gonadotrophins, thereby stimulating the gonads of the adjoined intact member. The resulting ovarian secretions do not reach the pituitary of the castrated partner and hence exert no inhibitory influence on it. Using substitute steroids administered from the time of spaying, it has thus been possible to ascertain their ability to inhibit the castration-induced hypersecretion of gonadotrophins. The uterus of the castrate provides an index of the estrogenicity of the administered steroid.

Meyer and Hertz (1937) demonstrated convincingly that larger doses of estrogen or androgen are required to inhibit the pituitary of a male than of a female rat. In each the degree of gonadal inhibition in the intact member was roughly proportional to the dose of sex steroid administered to the conjoined castrate. Biddulph, Meyer and Gumbreck (1940) observed that the minimal amounts of sex hormones required for complete inhibition of the postcastration rise in secretion of pituitary gonadotrophins were in females: 0.025  $\mu\text{g}$ . estradiol, 1.5  $\mu\text{g}$ . estriol, 1000  $\mu\text{g}$ . progesterone; and in males: 0.15  $\mu\text{g}$ . estradiol, 10  $\mu\text{g}$ . estriol, and 1000  $\mu\text{g}$ . progesterone. These workers also noted that the order of effectiveness of estrogens in suppressing gonadotrophin secretion paralleled the order of their capacity to produce vaginal cornification in rats, *viz.*, estradiol, estrone, and estriol.

In male animals estrogen damages the spermatogenic epithelium of the testes to the point that spermatogenesis is completely interrupted and the testes shrink to infantile size. At the same time the basophils of the pituitary are severely degranulated and reduced in numbers relative to other cell types, and the gonadotrophic potency of

the pituitary nearly vanishes. In the human male the excretion of urinary gonadotrophins is sharply reduced.

#### D. EFFECT OF ESTROGEN ON LUTEINIZING HORMONE AND LUTEOTROPHIN HORMONE SECRETION

An important consideration in assessing the action of steroids on pituitary function is the effect these have on the output of the luteinizing hormone. In most of the prior discussion reference to inhibition of gonadotrophin secretion has been to that of FSH. The assumption that estrogen acts in some manner to elicit a more effective luteinizing stimulus from the pituitary appears in nearly all papers dealing with pituitary-gonadal relationships. It constitutes a key point in all theories so far advanced to explain sexual periodicity in the female. The idea that estrogen may act to release LH originated with the "Hohlweg effect." This author (1934) found corpora lutea appearing in the ovaries of immature rats as the result of a single injection of estrogen. This response has not been obtained by other workers (Bradbury, 1947; Greep and Chester Jones, 1950a) using 21-day-old immature rats. It seems that the response is obtained only if the rats are nearing sexual maturity (Burrows, 1949). In adult rats massive daily doses of estrogen induce a type of pseudopregnancy and have a decided effect on the corpora lutea; they increase in size to resemble corpora lutea gravidari, and are functional as shown by their ability to maintain diestrous vaginal smears for 3 weeks in face of heavy estrogen treatment (Merekell and Nelson, 1940). To what extent such changes are due to LH or LTH, or both, is not clear. It might be expected that the large amount of estrogen would suppress LH secretion. If this were the case, continued LTH secretion would be independent of estrogen titers and, furthermore, would be capable of both maintaining and evoking secretion from the corpus luteum. In the rat, at least, this seems to be consonant with the capacity of pituitary homografts to secrete LTH selectively (Everett, 1956). Hellbaum and Greep (1940, 1943) noted that the pituitaries of castrated rats treated with estro-

gen for more than 20 days gradually lost their LH potency. They presumed that the LH component was released, but they were not able to detect it in the bloodstream with certainty. Greep and Chester Jones (1950b) tried to demonstrate by several means an LH-releasing action of estrogen in intact and gonadectomized rats of both sexes, but were forced to the conclusion that the fundamental effect of estrogen on the pituitary appeared to be to reduce the synthesis and storage of LH. A further point against the concept that estrogen triggers off an outpouring of LH from the pituitary is the fact that no sudden upsurge in LH activity has been observed in the male by an injection of estrogen, as judged by the condition of the testicular Leydig cells or by the size and histologic appearance of the ventral prostate.

There is evidence, however, favoring the concept that estrogen promotes release of LH. Funnell, Keaty and Hellbaum (1951) administered estrogen to a selected group of patients manifesting classical menopausal symptoms and were able to demonstrate LH activity in the urine where previously only FSH activity had been detectable. Confirmatory results have been reported by Brown (1956, 1959) using patients with secondary amenorrhoea.

The relation of estrogen to ovulation bears on the purported LH-releasing action of this substance. Everett, Sawyer and Markee (1949) succeeded in hastening ovulation in normal cycling rats by a properly timed injection of estrogen, but the response is not specific inasmuch as other substances, including progesterone, can produce the same effect. The work of Everett (1948) and co-workers (for review see his chapter in this book) suggests that estrogen may act on the anterior hypophysis indirectly through some neural, conceivably hypothalamic, mechanism. Estrogens have been used with variable, but generally poor, success in promoting ovulation. The fact that the estrous rabbit does not ovulate in response to injected estrone (Bachman, 1935) is not considered critical evidence, since ovulation in this species normally involves neural excitations associated with mating. More decisively the persistent-

estrous rat, which ovulates with such regularity after the administration of progesterone (Everett, 1940; Hillarp, 1949; Greep, 1953) or testosterone (Marvin, 1948), does not thus respond to estrogen unless pretreated for several days with progesterone (Everett, 1950). The latter result indicates that progesterone may synergize with or otherwise facilitate the LH-releasing action of estrogen. Hammond, Jr. (1945), on the other hand, succeeded in obtaining ovulation in anestrus sheep with low, but not with high, doses of estrogen. It would seem that the effect of estrogen on LH release varies between species and within species and is greatly influenced by the age of the animal, dosage used, and the time in the sex cycle at which treatment is instituted.

#### E. DIFFERENTIAL EFFECTS OF GONADAL STEROIDS ON FOLLICLE-STIMULATING HORMONE AND LUTEINIZING HORMONE SECRETION

The root of the matter in the regulation of gonadal function is the interplay of FSH and LH with the sex steroids. With respect to estrogens, the results do not lead to a clear-cut conclusion. Paesi (1952) provided data on a series of immature rats treated for 7 days with doses of estradiol benzoate, ranging from 0.0002 to 100  $\mu\text{g}$ . daily. The dose-response curve representing the effect of estrogen on ovarian weight was diphasic. Doses of 0.01 to 0.05  $\mu\text{g}$ . daily decreased the ovarian weight, whereas greater amounts up to 10  $\mu\text{g}$ . increased the ovarian weight slightly; however, only with 100  $\mu\text{g}$ . did the gain attain significance. The decrease in ovarian weight with low doses represents, he believes, an impairment of LH release, inasmuch as the ovarian interstitium seemed deficient. The enhanced ovarian weight with excessive dosage was presumed to be due either to increased FSH release or to FSH enhancement by released LH, as suggested by the stimulated interstitium. It is to be noted, however, that even in hypophysectomized immature female rats, excessive doses of estrogen produced significant ovarian enlargement and stimulate the development of an unusual number of medium sized "solid" follicles (Williams, 1940; Pencharz, 1940; Gaarenstroom and de Jongh, 1946; Payne and Hellbaum, 1955).

Bradbury (1947) proposed that the effects of estrogen on pituitary gonadotrophic functions are made more accountable when the results are considered in terms of acute and chronic estrogen treatment. The latter is well known to suppress gonadotrophic function and to deplete the gonadotrophin content. His acute experiments lasted only 48 to 120 hours and revealed a significant increase in ovarian weight, which confirms the results reported by Price and Ortiz (1944) and others. Greep and Chester Jones (1950b) also obtained a confirming result and showed further than the reaction was dependent on the presence of the pituitary. In this connection it is pertinent to note that Bradbury found a concurrent reduction in pituitary gonadotrophic potency at 72 to 120 hours after the injection of estrogen and concluded that the initial action of estrogen is to release gonadotrophin (unspecified, but the effect is mainly that of FSH). The stimulated ovaries showed in addition to accelerated follicular growth a swollen interstitium, suggesting that both FSH and LH had been released. The interstitial cell change was not confirmed in a later study (Greep and Chester Jones, 1950b). Thus, although it seems clear that under a given circumstance the immediate reaction to estrogen may be a slight upsurge in either FSH release or enhancement of FSH action, it is unlikely that FSH production or release is normally dependent on estrogenic action, since both its synthesis and release are greatest when no estrogen is present.

Meyer, Biddulph and Finerty (1946), Gaarenstroom and de Jongh (1948), Greep and Chester Jones (1950a, b), and Byrnes and Meyer (1951b) attempted involved analyses of the effect of gonadal steroids on pituitary function in terms of the separate gonadotrophins, FSH and LH. The wide divergence in their accounts emphasizes how poorly these matters are understood.

#### F. EFFECTS OF ANDROGENS ON PITUITARY GONADOTROPHINS

Considerations similar to those enumerated in our discussion of the estrogens apply to the influence of androgens on pituitary gonadotrophins, yet with well defined differences. The effects of androgens have been studied in females quite as much as in males.



The early idea that the gonadal hormones were sex specific has been abandoned and the possibility of abnormal functioning is hardly considered when androgens are studied in the female. Perhaps it should be, because in many females among the Mammalia androgens are not known to have a physiologic role. There is much doubt also as to how importantly androgens contribute to the regulation of the pituitary in the female. For the most part, injection of androgen into female mammals produces a deleterious effect on ovarian development, structure, and cyclic functions. Two exceptions may be noted: van Wagenen (1949) injected sexually immature female monkeys with androgen for long periods and obtained a remarkable hastening of the appearance of puberty. The age at first menses was, in fact, reduced by nearly one-half. Androgen injections have also been used successfully to promote ovulation in persistent-estrous rats (Marvin, 1948).

Very soon after the pure androgenic steroids became available, it was established that these substances in adequate dosage (which varied according to the androgenicity of the compound) (1) caused a partial reduction of the pituitary gonadotrophic potency in castrated rats (Heller, Segaloff and Nelson, 1943), and (2) prevented the appearance of castration cells in the pituitary (Nelson, 1935; Nelson and Merckel, 1937a; Wolfe and Hamilton, 1937). The work of Hertz and Meyer (1937) and Nelson (1937) placed androgen-pituitary relationships on a quantitative basis. The relative efficiency of testosterone propionate and dehydroandrosterone in restricting the secretion of gonadotrophins by gonadectomized parabionts was determined by Hertz and Meyer (1937). Each compound in adequate dosage completely suppressed secretion of pituitary gonadotrophins as shown by absence of ovarian stimulation in the intact partner. Using these compounds in dosages less than that required to produce complete ovarian suppression, the degree of inhibition was found to be roughly proportional to the dose.

The androgens evoke clear-cut alterations in pituitary FSH and LH potency and no doubt are in part responsible for the quantitative sex differences in the pituitary

content and level of secretion of these gonadotrophins. On a comparative basis the pituitaries of adult males are distinctly richer in FSH than those of adult females (Hellbaum and Greep, 1938; Greep and Chester Jones, 1950b; Hoogstra and Paesi, 1955; Paesi, de Jongh, Hoogstra and Engellbregt, 1955), yet in the absence of androgen, as after castration, FSH increases as though an inhibiting influence had been removed. Long-term castrates given large doses of testosterone showed only a partial (Heller, Segaloff and Nelson, 1943) or no reduction in gonadotrophic potency. Examining the effect of androgens on the pituitary gonadotrophins of adult intact female rats, Greep and Chester Jones (1950b) found unexpectedly that within a specified range of dosage (0.1 to 0.5 mg. of testosterone propionate per day), FSH potency was elevated over that of untreated controls. Similar findings have been reported by Pineus (1950), Hoogstra and Paesi (1957), and Paesi, de Jongh and Willemsse (1958). Hoogstra and Paesi made the additional observation that the increase of pituitary FSH with androgen treatment (2 mg. of testosterone propionate daily) is not limited to intact females, but occurs in intact males and gonadectomized males and females as well. Furthermore, the response was not modified by simultaneous administration of 2  $\mu$ g. of estradiol benzoate.

Interest in the androgen-LH relationship is stimulated by the consideration that LH acting independently evokes androgen secretion by the testis, whereas its ability to elicit the secretion of estrogen by the ovary necessarily involves other factors, notably FSH. It would be expected then that the LH-testicular androgen relationship might be subject to somewhat more precise analysis on the basis of experimental data, but this has not been fully realized. There is some evidence that a push-pull mechanism is operative. The injection of testosterone for more than 30 days results in the elimination of LH potency from the pituitary glands of long-term gonadectomized rats (Hellbaum and Greep, 1943; Paesi, de Jongh and Willemsse, 1958). The latter authors concluded that testosterone depressed the LH content to lower levels in intact rats

than in gonadectomized animals of the same sex.

Intact adult female rats treated with testosterone show cessation of cycles (Nelson and Merkel, 1937b), involution of the corpora lutea, and a marked reduction in ovarian weight (Greep and Chester Jones, 1950b). The minimal effective inhibitory dose is 10  $\mu$ g. daily. A dosage 50 times greater (0.5 mg.), however, does not produce the same severe degree of ovarian atrophy that is seen with long-term estrogen treatment. The ovaries, although small, have a translucent blisterly appearance. This is due to the presence of a small number of semi-atrophic vesicular follicles and to the relatively great reduction in amount of ovarian lipids (Greep and Chester Jones, 1950). From the foregoing evidence it would appear that androgen treatment favors FSH storage over FSH release and that androgen can suppress both the elaboration and release of LH.

The effect of exogenous androgens on the gonads of the intact male rat varies widely with the dose administered. Low to moderate doses of testosterone produced severe testicular injury (Selye and Friedman, 1941; Shay, Gershon-Cohen, Paschkis and Fels, 1941; Rubinstein and Kurland, 1941; Ludwig, 1950; Greep and Chester Jones, 1950b); maximal reduction in testes weight and complete inhibition of spermatogenesis were obtained with 0.1 mg. of testosterone propionate daily for 30 to 45 days. Large doses of androgen (2 to 20 mg. daily) maintained testis size and sperm production even in the absence of the hypophysis (Walsh, Cuyler and McCullagh, 1934; Cutuly, McCullagh and Cutuly, 1937; Nelson, 1937; Leathem, 1944). The response is produced by direct action on the tubular epithelium of the testes. A similar effect was produced in hypophysectomized mice (Nelson and Merkel, 1938), rabbits (Greep, 1939), and monkeys (P. E. Smith, 1944). Local maintenance of spermatogenesis has also been observed in the tubules in close proximity to intratesticular implants of testosterone pellets in hypophysectomized rats (Dvoskin, 1947) and monkeys (P. E. Smith, 1944). Several androgenic steroids and their derivatives have been tested in regard to their ability to maintain the testes in hypophy-

sectomized rats (Nelson, 1937). It is of interest that the spermatogenic properties of the various androgens were not found to be related to their androgenicity as measured by ability of the compounds to stimulate the rat prostate or the capon's comb. Pregnenolone, a nonandrogenic steroid, did not reinitiate spermatogenesis, but it did partly maintain spermatogenesis, when given immediately after hypophysectomy (Dvoskin, 1949).

In man the testes apparently are not benefited by exogenous androgens at any dose level but are, on the contrary, affected adversely. In 1940 Heckel noted a drop in sperm count during testosterone therapy, a finding that is now a common clinical experience. In the past few years much interest has centered on the recovery phase. Heller, Nelson, Hill, Henderson, Maddock, Jungck, Paulsen and Mortimore (1950), Heller, Nelson, Maddock, Jungck, Paulsen and Mortimore (1951), and Ewell, Munson and Salter (1950) reported finding a rebound in spermatogenesis and in sperm counts following the cessation of androgen therapy. They observed that for a year or more following cessation of treatment the sperm counts may be well above the pretreatment levels and that sclerosis and hyalinization of the tubular walls may be lessened. The number of cases studied has been extended (Heckel, Rosso and Kestel, 1951; Heckel and McDonald, 1952; Swyer, 1956) with poor agreement as to improvement in sperm count. Because the already subnormal testis is further damaged by androgen, there is need for additional study of this interesting phenomenon.

Although rats and man have been extensively investigated, little information is available about other mammals. Wells (1943) injected male ground squirrels with testosterone in daily doses from 0.05 to 20 mg. beginning just before the peak of the annual sexual cycle. He found that the interstitial cells were severely damaged and the testes were somewhat reduced in size, but the spermatogenic capacity of tubular epithelium was unimpaired. His assumption that the release of ICSH was being inhibited has been amply substantiated by other studies. His failure to find tubular atrophy with the low doses is rather sur-

prising and one can only conjecture that the release of FSH was not being interfered with. The higher doses were obviously adequate for direct tubular maintenance irrespective of ICSH or FSH inhibition.

#### G. OTHER STEROIDS AND OXIDATION PRODUCTS

Several synthetic steroids related to the sex hormones but which exhibit no estrogenic activity have proved to be without effect on pituitary gonadotrophin content (Mortimore, Paulsen and Heller, 1951). Lipoadrenal extract and desoxycorticosterone acetate produced some uterine development and some inhibition of hypophyseal secretion of gonadotrophins, whereas cortisone was neither estrogenic nor inhibitory of gonadotrophin secretion (Byrnes and Shipley, 1950). Although exogenous estrogens and androgens inhibited the development of intrasplenic ovarian grafts in guinea pigs (Lipschütz, Iglesias, Bruzzone, Humerez and Penaranda, 1948), and rats (Takewaki and Maekawa, 1952), progesterone and desoxycorticosterone failed to do so.

O. W. Smith (1944, 1945) maintained on the basis of her investigations that it is not the circulating gonadal hormones *per se* which influence pituitary function and potency but the oxidation products of these hormones. She used mainly the lactone of estrone prepared by W. W. Westerfeld and by Alan Mather. In her hands the lactone both increased the size of the pituitary and decreased its gonadotrophic potency. The studies of Bradbury (1947) and of Mortimore, Paulsen and Heller (1951) suggested that any pituitary responses induced by estradiolactone may be attributable to its estrogenicity, which is approximately 1/100 that of estrone in regard to both estrogenic activity and pituitary gonadotrophic inhibition.

#### H. EFFECT OF PROGESTERONE ON PITUITARY GONADOTROPHIC FUNCTIONS

Species vary in the extent to which the secretion of gonadotrophins is influenced by progesterone. In the guinea pig which has a 16- to 17-day cycle, progesterone inhibits the preovulatory swelling (generally attributed to LH), but growth up to this point is unaffected (Dempsey, 1937). In rodents

with short estrous cycles the influence of progesterone on the secretion of gonadotrophins appears to be minor, in that moderate doses do not alter ovarian maturation or cyclic functions (Greep and Chester Jones, 1950b). Although some inhibition of gonadal functions can be demonstrated after massive doses of progesterone, interpretation is always complicated by the weak estrogenicity and androgenicity of the compound. Similarly, total gonadotrophin content of the pituitary is little altered by progesterone.

Although progesterone is primarily a product of the corpus luteum and exerts a major function during the luteal (and gravid) phase of the cycle, there are strong indications that in some species the secretion of progesterone is initiated in follicles before ovulation (guinea pig, Dempsey, Hertz, and Young, 1936; rat, Astwood, 1939; Boling and Blandau, 1939; mouse, Ring, 1944). Consistent with this conclusion is the finding that the peak level of progesterone in the blood of cyclic rats coincides with the proestrus as determined by the Hooker-Forbes assay (Constantinides, 1947). By the same means progesterone activity has been found in the blood of laying hens but not in nonlaying hens or roosters (Fraps, Hooker and Forbes, 1948, 1949). The preovulatory appearance of progesterone is believed to be important in the elicitation of behavioral estrus (see chapter by Young) and as a component of the hypothalamo-pituitary triggering mechanism for ovulation (see chapter by Everett).

Current interest in the progesterone regulation of gonadotrophic functions has been focused on the latter mechanism. Progesterone induces or at least hastens ovulation in cyclic-estrous rats (Everett and Sawyer, 1949a), persistent-estrous rats (Everett, 1940), rabbits (Sawyer, Everett and Markee, 1950), hens (Fraps and Dury, 1943; Rotheild and Fraps, 1949), cattle (Hansel and Trimberger, 1952), anestrus ewes (T. J. Robinson, 1954), anovulatory monkeys (Pfeiffer, 1950), and women (Rotheild and Koh, 1951). Notably too, both ovulation and luteinization have been observed in ovarian grafts in castrated male rats following administration of progesterone (Kempf, 1949, 1950). Such grafts normally show only

follicular development. Since ovulation depends on an acute discharge of LH (discussed elsewhere), the question is raised as to the role of progesterone in this regard. Firstly, it is important to note that progesterone probably is not in itself a releasing agent; rather, it appears to synergize with estrogen to facilitate the triggering mechanism. Moreover, although the possibility exists that progesterone acts directly on the hypophysial cells to release LH, an impressive body of evidence suggests that progesterone promotes LH release (indirectly) by acting on the central nervous system—probably the hypothalamus (for review see Markee, Everett and Sawyer, 1952 and the chapter by Everett). Under other conditions, quite the reverse of being a stimulus for ovulation, progesterone is a potent inhibitor of ovulation. There can be little doubt that the suppression of ovulation during the luteal and gravid phases of the reproductive cycle is due to progesterone. Single doses of progesterone prevent ovulation in the mated rabbit, and continued high dosage to cyclic rats (Phillips, 1937), guinea pigs (Moller-Christensen and Fonss-Beech, 1940), sheep (Dutt and Casida, 1948), and cattle (Ulberg, Christian and Casida, 1951) postpones ovulation indefinitely.

#### I. NEUROHYPOPHYSEAL INFLUENCES ON GONADOTROPHIN SECRETION

Recent evidence reviewed by Benson and Cowie (1957) has tended to link the posterior lobe of the hypophysis with the mechanism for release of prolactin. Many years ago Selye (1934) demonstrated that the nervous excitation of suckling served to maintain lactation. A reflex arc was believed to be involved and this has been partially identified by later studies. The stimulus of suckling has been shown to act through the central nervous system (Eayrs and Baddeley, 1956) and the hypothalamo-neurohypophysial axis (Andersson, 1951a, b) and to effect the release of oxytocin (Cross and Harris, 1950, 1951). The latter causes contraction of the myoepithelial components of the alveoli, thereby effecting milk ejection (let-down). A number of workers (see Donker, Koshi and Petersen, 1954) have obtained evidence that the beneficial effect

of oxytocin on lactation is more pronounced than can be accounted for on the basis of change in intra-alveolar pressure. The question then arose as to whether oxytocin has an indirect as well as a direct action on the mammary structure. Benson and Folley (1956, 1957) noted that continued administration of synthetic or commercial oxytocin retards mammary involution in lactating rats following the interruption of suckling. Inasmuch as a similar effect was obtained by injecting prolactin, Benson and Folley have speculated that oxytocin may provide the stimulus for release of prolactin, *ergo* LTH, from the anterior pituitary.

Other lines of evidence have also suggested a relationship between the posterior pituitary and gonadotrophic functions of the anterior lobe. Deselin (1956a, b) and Stutinsky (1957) have shown in rats that injections of oxytocin at the time of estrus produce a pseudopregnancy reaction. The results suggested enhancement of LTH release, but the significance of these findings has been questioned because the response is not specific for oxytocin. Pseudopregnancy has been induced by the administration of a variety of non-specific substances, such as plant juice extract (Dury and Bradbury, 1942) and ovalbumin, etc. (Swingle, Seay, Perlmutt, Collins, Barlow and Fedor, 1951) to female rats at the time of estrus.

#### V. Anatomic Features Important to Modern Concepts of Pituitary Gonadotrophic Function

In terms of general morphology there is little to add to the classical knowledge concerning the hypophysis of mammals. Present considerations turn largely on the details of the vascular supply and the innervation of the gland. In this regard the literature has been notably enriched by Green's (1951a, 1952) comprehensive study of 76 species ranging from amphioxus to man and by Wingstrand's monograph (1951) on the structure and development of the avian pituitary. The notable advances which have been made in the cytologic and electron microscopic identification of cell types in the pars distalis are reviewed in the chapter by Purves.

A distinct regional lobulation of the pars distalis, first described in the chicken and

duck, was subsequently shown to be widely characteristic of birds (Rahn and Painter, 1941, 18 species; Wingstrand, 1951a, 50 genera). According to these authors the pars distalis in birds comprises two histologically distinct parts, which they designate "cephalic" and "caudal" lobes. The zonation develops during embryonic life and, in stained preparations of the adult gland, is evident to the naked eye. A conspicuous regional distribution of specific cell types has been noted also in the anuran hypophysis (Dawson, 1957). These observations in lower forms provide an evolutionary background for the numerous instances of regional distribution of cell types described in mammalian pituitaries (Dawson, 1939, 1948; Halmi, 1950, 1952; Purves and Griesbach, 1951a, b, 1955; Ferrer and Danni, 1954). Ferrer (1957) noted a correlation between the arrangement of the vascular supply to the adenohypophysis in rats and the pattern of distribution of basophils. Three zones were recognized, each of which has a particular basophilic picture. Dawson (1957) likewise noted a rather specific relationship of cell types to the vascular pattern in the frog. The observation that a pars intermedia is absent in chickens (Kleinholz and Rahn, 1939) has been confirmed in all species of birds thus far examined (Rahn and Painter, 1941; Wingstrand, 1951; Marshall, 1955).

#### A. INNERVATION OF THE HYPOPHYSIS

The question of the innervation of the hypophysis has become a matter of critical importance in the elucidation of mechanisms regulating the various functions of this organ, especially those of the anterior lobe. Fibers of hypothalamic origin sweep down the infundibulum in great numbers to end mainly in the processus infundibularis and, to a minor and perhaps questionable extent, along the infundibular stem. Early workers generally found some of these neurohypophyseal fibers entering the pars intermedia and terminating in the pars distalis, but never in numbers to inspire confidence in their significance.

Vazquez-Lopez (1949, 1953) advocated the view that there is an adequate anatomic basis for neural control of the adenohypophysis. Using modifications of the classical silver impregnation techniques of Cajal

and Rio del Hortega, he observed presumptive nerve fibers coursing through the pars distalis of the rabbit. These terminated with typical nerve endings in connection with the glandular cells. The fibers were claimed to originate from the tractus hypophysialis, to cross over to the pars tuberalis in abundance, and in fewer numbers to follow the general course of the vascular elements to the pars distalis. In 1952 Vazquez-Lopez and Williams, reporting on their examination of these relationships in the rat, described the presence of rather sizeable nerve bundles in the marginal zone of the median eminence, and in the pars tuberalis. They were uncertain of the origin and course of these fibers. In a study of the horse Metuzals (1954), using the Bielehowsky and the Gomori staining methods, traced presumptive nerve fibers from the hypothalamus to their endings in the pars distalis. Of the fibers seen in the pars tuberalis, most are held by Stutinsky (1948), Christ (1951), Nowakowski (1951), and Benoit and Assenmacher (1951a) to be derived from similar fibers which have been observed in the marginal zone of the median eminence and along the inferior aspect of the neural stalk. A dense "secretomotor ground plexus" specifically innervating the gland cells has been described by Metuzals (1956). With respect to Metuzals' preparations, A. J. Marshall (1955) states that they "undoubtedly reveal an extensive and specific innervation of glandular cells in the pars distalis." In the ferret, also, sparse nonmyelinated nerve fibers and end organs of characteristic appearance have been observed (R. N. Smith, 1956) by a modification of Ranson's pyridine-silver method. In all these instances the nuclei of origin of the fibers remain obscure.

Truscott (1944) and Wingstrand (1951a) among others described autonomic fibers entering with and terminating along the sinusoids of the anterior lobe. In the pars distalis of man Hagen (1951) reported the finding of extremely fine fibrillar networks, which were believed to enter the pars distalis from the capsule of the gland; and Westman, Jacobsen and Hillarp (1943) reported the persistence of an autonomic fiber system in the anterior pituitaries of rabbits after cervical sympathectomy. Metuzals

(1956), applying the Bielechowsky-Gros technique to the adenohypophysis of the duck, demonstrated in the capsule and throughout the gland the presence of an autonomic neural formation composed of large strands of nerve fibers replete with ganglion cells and end formations adjacent to parenchymal cells. The presence of even these minor neural contributions to the pars distalis has been vigorously denied by Green (1951b). He was not able to identify such perivascular fibers in the pars distalis, although they were found in the pars tuberalis.

It is significant that all attempts at influencing pituitary secretory function by sympathectomy or by proximal stimulation of the cervical sympathetic trunk have yielded either negative or equivocal findings (Friedgood and Pineus, 1935; Friedgood and Cannon, 1940). Although bilateral removal of the superior cervical or stellate ganglia of the sympathetic system in ferrets has been shown to abolish (Abrams, Marshall and Thomson, 1954) or delay (Donovan and Van der Werff ten Bosch, 1956) the estrous response to added illumination, the latter authors believe this may be accounted for on the basis of an indirect effect; namely, a diminished amount of light impinging on the retina. All the operated animals showed a marked Horner's syndrome, *i.e.*, globe recession, ptosis, and narrowing of palpebral fissure.

From the foregoing evidence, the conclusion seems clear that the regulation of the pars distalis by secretomotor nerves must be slight, if indeed there is such regulation. All the instances of identification of nerve fibers are open to doubt for the reason that the staining methods do not adequately differentiate nerves from reticular connective tissue fibers. It is to be noted also that by use of phase contrast microscopy in combination with staining procedures, Green (1951b) found no fibers in the rabbit or human pars distalis that could with certainty be identified as nerves.

#### B. THE MEDIAN EMINENCE AND THE INFUNDIBULAR STEM

The eminentia has become a focus of interest in attempts to understand neuro-endocrine relationships, because this area is

contiguous with both the hypothalamus and the hypophysis. It is present in vertebrates from amphibians to mammals, and its structure is quite uniform throughout the birds and mammals (Green, 1951a; Wingstrand, 1951b; Nowakowski, 1951). The median eminence is comprised of an inner *ependymal zone*, a middle *coarse-fiber zone* made up of the axons of the supraoptic-hypophyscal tract, and a so-called *glandular zone* at the surface. The name of the latter was derived from the density of the capillary skein on its surface—it has also been termed the *peripheral or marginal zone*.

The glandular zone contains the capillary loops of the primary portal plexus (described below), perpendicularly arranged fibers extending from cells in the ependymal zone and some fibers of nerve cell origin. The latter lie along the base of the glandular zone from which recurrent loops are said to extend toward the surface (Wingstrand, 1951b; Nowakowski, 1952; Assenmacher and Benoit, 1953a, b). Stutinsky (1951) and Vazquez-Lopez and Williams (1952) believed that they have demonstrated fibers from the tractus hypophysius crossing the marginal zone to enter the pars tuberalis, thence to follow the course of the portal veins toward the pars distalis. The existence of such fibers is denied by Rumbaur (1950), Wingstrand (1951a), and Palay (1953a). The innervation of the glandular layer is, as Wingstrand (1951a) states, the key to the postulated control of the pars distalis by a neurovascular mechanism. For birds he states: "No nerve fibers have been seen leaving the eminentia but invariably turn back when they reach the surface. . . ."

The glandular zone contains a flocculent colloid that is demonstrable with the azan trichrome stain, but there is no agreement as to whether this material stains selectively with chrome alum hematoxylin (Gomori-positive) like the neurosecretory substance in the tractus hypophysius. Benoit finds abundant Gomori-positive material in the glandular zone in the duck, whereas Wingstrand's examination of a great variety of birds revealed faintly positive reacting colloid only in a restricted area in the rostral portion of the median eminence. He doubted that it is similar to the heavily staining neurosecretory substance in the supraoptic-

hypophyseal tract. The central zone exhibits, of course, abundant Gomori-positive material.

In 1957 Dawson presented morphologic evidence of a closer neurovascular relationship in the median eminence of frogs than has yet been observed in mammals. Studying the hypothalamo-hypophyseal relationships at the level of the median eminence in sections stained by modifications of the chrome alum hemotoxylin-phloxine and the aldehyde fuchsin methods, he found that of the fibers from the preoptic tract a surprisingly large number enter and end in the median eminence and have a specific association with the vessels of the portal system. The final simple nerve terminals (dilated with secretion) and the selectively stained secretory substance were arranged in radial patterns about the capillaries. It has not been determined whether the amount of neurosecretory material accumulated about the vessels in the primary plexus is of functional significance, but Dawson noted a specific cell type scattered along the portal vessels as they enter the anterior lobe, and felt that the "rather specific morphologic pattern displayed" suggests a functional interaction of some kind between nervous components of the hypothalamus and glandular units of the anterior pituitary gland, mediated by way of the portal circulation.

#### C. THE HYPOPHYSICAL PORTAL CIRCULATORY SYSTEM

A system of hypophyseal portal vessels which drain the tuber cinereum above and supply the adenohypophysis below is present throughout the reptiles, birds, and mammals (Green, 1951). It is indicative of significance that in all these forms the portal vessels provide either the entire or the major vascular supply to the adenohypophysis. Wingstrand (1951a) found no afferent vessels to the pars distalis other than portal vessels in over 50 genera of birds. However, Benoit and Assenmacher (1951b) state that in ducks the pars distalis is inconstantly supplied by a few twigs passing directly from the superior hypophyseal arteries. Crooke (1952) expressed the opinion that the blood supply to the pars distalis in man must be almost entirely by way of the stalk vessels. In examination of over 300

human pituitaries, he found minute vessels entering from the capsule in only 6 instances. McConnell (1953) reached the conclusion that the pars distalis in man is supplied entirely by the hypophyseal portal vessels, a view which is substantiated by the results from a recent critical study by Xuereb, Pritchard and Daniel (1954a). The latter workers (1954b), however, made a further observation which is of cardinal significance. They discovered a vascular link between the neural lobe and the adenohypophysis. Thus, in addition to the "long" portal veins which drain the upper stalk region and supply the sinusoidal network of the anterior and lateral regions of the pars distalis, they found a variety of "short" portal vessels, which arise from an anastomotic link between the superior and inferior hypophyseal arteries on the lower margin of the infundibular stem. These "short" vessels supply the posterior portion of the pars distalis. It will be apparent, therefore, that even though the pars distalis derives all of its blood from the portal vessels, the source of this blood is not limited to that from the superior hypophyseal arteries as was previously thought, but can be supplied by the inferior hypophyseal arteries as well. The matter is of significance in that channels are now known to exist whereby some blood from the systemic circulation can reach the pars distalis without having passed through the primary plexus on the median eminence. Consequently, when the long portal vessels are severed, as in the transection of the pituitary stalk, the possibility remains that in some species collateral channels in the form of these short portal veins continue to supply a portion of the pars distalis.

From a study of the arrangement and structure of the hypophyseal vasculature, Wislocki and King (1936) inferred that the flow of blood in the hypophyseal portal veins was toward the anterior lobe and this has now been confirmed by decisive evidence from work on frogs (Green, 1947), birds (Wingstrand, 1951a), rats (Green and Harris, 1949; Barnett and Greep, 1951), and man (McConnell, 1953; Xuereb, Pritchard and Daniel, 1954a, b). In 1952 Nowakowski, on the basis of his studies of the cat, once more advanced the view that the flow of blood in the portal system is toward

the eminentia. It was his thought that the eminentia has a sensory innervation which registers the content of adeno-hypophysial hormones emanating from the pars distalis. The view seems to be completely untenable on anatomic grounds alone.

The capillaries in the primary plexus of the portal vessels show an unusual arrangement in most mammals. From the net which spreads thickly over the surface of the median eminence and the neural stalk, capillary loops and tufts protrude into the wall of the median eminence (Green, 1948; Xuereb, Prichard and Daniel, 1954a). They are not in close proximity with the large nerve tracts of the hypothalamo-hypophysial neurosecretory system. In birds and mammals they are approached but not closely surrounded by sparse fibrous elements, the nature and origin of which are obscure.

There is a mounting body of circumstantial evidence suggesting that the hypothalamus exerts a large measure of control over the secretory functions of the anterior pituitary. Such control might be effected either through direct nervous connections, the evidence for which (as we have just seen) is scant, or through a relay chain made up of a neural and a vascular link. Anatomically, at least, the latter exists in the form of the hypophysial portal system.

The neurohumoral concept as outlined by Harris (1947, 1948a) and Green and Harris (1947) holds that pertinent exteroceptive stimuli impinge upon the hypothalamus as the first way-station in the neurovascular reflex arc. Here the sex-related impulses are integrated with existing blood levels of circulating hormones, thence effector impulses travel by nerve conduction to the median eminence and effect the liberation of neurohumors (chemotransmitters). The latter are held to enter the primary plexus and to be distributed to and activate the cells of the pars distalis. A weakness in this theory is at the point of transfer of chemotransmitters from nerve to vessel in the median eminence. The anatomic relationship between the loops or endings of nerves of obscure origin and the capillaries, which lie either on the surface of the median eminence or extend tuft-like into its substance, has not been clearly defined.

#### D. THE HYPOTHALAMIC AND HYPOPHYSEAL MEDIATED SEXUAL FUNCTIONS

##### 1. *Environmental Stimuli*

A great number of instances are known in which reproductive processes are conditioned by or are dependent on environmental factors. Although animals breed at a season of the year that is propitious for the survival of their young—warmth and the availability of food being the major factors—this is not through choice on their part. In many birds and mammals the readying of the reproductive system for seasonal breeding and rearing of young is anchored to alterations in the physical environment, especially to changes in length of daylight—a subject which will not again bear expatiation (for a recent review see Amoroso and Matthews, 1955). Darkness, too, may not be an entirely passive stimulus (Burger, Bissonnette and Doolittle, 1942; Jenner and Engels, 1952; Kirkpatrick and Leopold, 1952), but this concept has not gone unchallenged (Hammond, Jr., 1953). Experiments involving total darkness, moreover, are often subject to the complication of reduced food intake. The ground squirrel (Wells and Zalesky, 1940) and the white-crowned sparrow (Farmer, Mewaldt and Irving, 1953) respond only to changes in the ambient temperature. Propagation in some tropical birds and amphibia is in like manner dependent on the beginning of a rainy season. Food becoming more plentiful at this time seems to be the mediating factor for many tropical birds. In England, certain frogs (Savage, 1935) are lured to the ponds by chemotactic stimuli arising from ripening algae, but spawning is dependent on another sequence of changes induced in the ionic composition of the water by the algal cycle and perceived through the frog's skin. Animals transported to the opposite hemisphere, generally adapt their breeding activities rather quickly to the same characteristic season irrespective of when it occurs in the calendar year (for review see F. H. A. Marshall, 1942; Burrows, 1949). In many birds, even with gonads in readiness for the mating season, the actual nesting often requires another complex set of extra-organismal stimuli, such as presence of food, presence of mate, density of colony, suitability



of breeding site, and avian display and courtship performances (A. J. Marshall, 1955, and chapter by Lehrman).

Thus, for most but not all of the seasonal breeding vertebrates, the primary excitations to breeding activity originate in one way or another in the external environment. Those structures most exposed to such stimuli are the skin and the specialized sense organs, particularly those for seeing, hearing, and smelling. It will be recalled that the sight of his mate incubating is sufficient to initiate in the male pigeon the secretion of crop milk (Patel, 1936). It is also not infrequent, especially among birds, that the presence of a mate is a prerequisite for ovulation. Here again, interesting observations have been made on the pigeon (Matthews, 1939). The female separately caged and denied sight of other birds does not ovulate; but if she is permitted to view, by means of a glass partition in the cage or a mirror, a separately caged male or even a female pigeon, or is allowed to see the mirror image of herself, ovulation and oviposition ensue. The stimulus which causes ovulation is clearly visual and not tactile, olfactory, or auditory. In sheep the presence of the ram is believed to hasten ovarian activity and estrus in ewes (Riches and Watson, 1954; Schinckel, 1954), and it is likely that here both sight and odors play a part.

It is apparent from observation of the behavior of domestic and laboratory mammals that strong nasogenital relationships exist, but the effect of sexual odors and olfactory stimulation on the sexual functions has received only cursory study. Pseudopregnancy has been induced in rats by simply applying a local anesthetic to the nasal mucosa (Shelesnyak and Rosen, 1938) and similar prolongations of luteal function were induced by bilateral excision of the sphenopalatine ganglion, but not by removal of the olfactory bulbs (Rosen, Shelesnyak and Zacharias, 1940). Local irritants applied to the nasal mucosa likewise did not affect the estrous cycle. These authors felt that the nervous factor involved was limited to the nonolfactory innervation of the nasal mucosa. Whitten (1956a) showed that mice rendered anosmic by removal of the olfactory bulbs have significantly smaller ovaries and uteri and fewer corpora lutea. No effect

was observed in anosmic males. In both male and female mice the body weights were reduced.

In a recent study Whitten (1956b) found that external stimuli associated with the male mouse modify the estrous cycle in the female. The incidence of mating after pairing was greatest on the 3rd night and was low on the 1st, 2nd, and 4th nights. The finding suggests that in some females the cycle was delayed, and in others it was advanced, by the presence of the male. In another experiment in which males were caged in a small basket within the females' cage for 2 days before pairing, the incidence of mating on the 1st night was greatly increased. Since presence of the males' excreta had a similar effect on the receptivity of the females, odors were thought to be an important factor in mediating this behavioral response.

The determinate-laying wild birds, *i.e.*, those which stop laying when the number of eggs characteristic of the species has been laid, probably perceive the stimulus for cessation of egg-laying through tactile sensations. Tactile stimuli are also known to come into play strongly during coitus. It is well known that in several mammals (rabbit, cat, mink, ferret, ground squirrel, short-tailed shrew) ovulation is dependent on the coital excitation of receptor areas not all of which are confined to the genitalia. The neural pathways involved are poorly understood.

Knowledge of the effect of sound on reproductive phenomena is exceedingly limited. It would be interesting to ascertain what sequential role, if any, various songs and mating calls play in releasing the manifestations of procreative processes. It is probably of no significance that Benoit (1955) failed to alter the sexual maturation in young drakes with continuous noise, and only indicative that Vaugien (1951) found a hastening of egg-laying in parakeets placed in small containers within hearing distance of an aviary where others of the species were mating. Control females similarly caged beyond hearing range did not lay. Sound, however, was not the only variable in these experiments.

Thus, many extrinsic factors act in some manner to influence the secretion of gonado-

trophins by the anterior hypophysis. Obviously, central nervous pathways are involved, but the anterior pituitary has so little, if any, innervation that it is almost certain that none of the impulses are carried directly to the pituitary by this means. An alternative connecting pathway between brain and hypophysis exists in the form of the portal vessels. One of the most pressing problems in endocrinology is to define the pathways and elucidate the mechanisms by which such exteroceptive stimuli as those mentioned above effect the secretory functions of the anterior hypophysis.

The hypothalamus serves in other respects to receive impulses from higher afferent centers and to instrument these into responses that relate to vegetative functions, for example, breathing, sleeping, and body temperature. It is also known to be the seat of neural mechanisms concerned with sex functions. By location and neural connections the hypothalamus could well be attuned to the reception and integration of sex-related impulses of variable sources. It has often been observed clinically that tumors of the hypothalamus are associated with disturbed sexual functions. Moreover, anxiety states may lead to a cessation of menstrual cycles or impotence without evidence of organic disease. The supposition is that chemotransmitters of some sort, arising in the diencephalon, reach the pituitary by way of the portal veins. Alternatively, no other explanation of the existing evidence is available. Such a chemotransmitter has not yet been identified (Zuckerman, 1954). Extracts of the hypothalamus have thus far provided only inconclusive evidence with respect to release of another trophic factor, corticotrophin, from the adenohypophysis (Guillemin, Hearn, C'heek and Housholder, 1957).

## 2. *Electrical Stimulation of the Hypothalamus*

A hopeful means of increasing the secretory activity of the anterior pituitary was suggested by the observation that ovulation and pseudopregnancy could be produced by application of a strong current to the head or spinal cord in estrous rabbits (Marshall and Verney, 1936) and rats (Harris, 1936). With refinement in the technique it has be-

come possible to apply such stimulation to precise areas in the pituitary and suprasellar region. Moreover, by use of implanted electrodes and the remote induction of stimulation it is possible to apply electric excitation of controlled intensity to precise areas for almost any length of time in unanesthetized animals (de Groot and Harris, 1950, reviewed by Harris, 1955). The method has been used mainly in connection with the study of ovulation in rabbits and pseudopregnancy in rats, but the method is suitable for much wider application in the study of mechanisms which regulate the functions of the pars distalis. By successive steps an area wherein stimulation leads to ovulation in estrous rabbits has been fairly well delimited (Harris, 1937; Haterius and Derbyshire, 1937; Markee, Sawyer and Hollinshead, 1946; Harris, 1948b).

Stimulation of the various lobes of the hypophysis and of the neurohypophyseal stalk in the unanesthetized rabbit does not promote ovulation, whereas ovulation is quite regularly induced when the stimulating electrodes are in the tuber cinereum just anterior to the median eminence or in areas of the anterior hypothalamus. No part of the supraoptic-hypophyseal tract yielded a positive result. These observations provide strong support for the belief that the hypothalamus exerts a profound effect on the reproductive functions of the pars distalis and show quite conclusively that the connecting link to the pituitary is not neural in character. They otherwise prove nothing with respect to the essentiality of the portal circulation in the mediation of these responses.

Stimulation of the cervical sympathetic fibers leading to the hypophysis neither induces nor interferes with ovulation in rabbits, according to Haterius (1934) and Markee, Sawyer and Hollinshead (1946). The few successful instances noted by Friedgood and Pineus (1935) might have been due to spread of the stimulus to the hypothalamus, or a response to handling. It is pertinent to note in this connection that neither sympathetic nor parasympathetic denervation of the hypophysis has led to any detectable change in pituitary functions.

### 3. Lesions in the Hypothalamus

The puzzling clinical association of lesions in or trauma to the base of the brain in the region of the diencephalon and disorders of the reproductive system set workers to probing this area of the brain in experimental animals as long ago as the turn of the century (for review of the early literature and critical analysis of the evidence, see Anderson and Haymaker, 1948a, b). Clinical or experimental lesions, destroying much of the hypothalamus but leaving the hypophysis intact, ordinarily resulted in genital atrophy accompanied by obesity (Fröhlich type syndrome). Diabetes insipidus did or did not ensue, depending on whether the lesion disrupted hypothalamic neural connections with the neurohypophysis. A significant advance was made in 1927 when Smith discovered quite by accident that the chromic acid he was injecting into the sella of rats to destroy pituitary tissues led to extreme obesity through damage to adjacent areas of the brain. It remained for Cahane and Cahane (1935, 1936) to dissociate in rats the sequelae of adiposity and deficiencies in the reproductive system by means of carefully placed lesions. Rats with lesions in the infundibulum showed severe testicular or ovarian atrophy and cessation of estrous cycles with no obesity. Dey (1941, 1943a-c), Dey, Fisher, Berry and Ranson (1940), and Dey, Leininger and Ranson (1942) were among the first to use stereotaxic instruments in a major study of the effect of bilaterally placed hypothalamic lesions on the reproductive organs and sexual behavior. They were able by this means to produce two distinct categories of sexual response in female guinea pigs. (1) Animals with lesions in the median eminence exhibited ovarian atrophy and loss of all reproductive functions. (2) Animals with lesions in the anterior hypothalamus remained in continuous estrus and the ovaries were filled with large Graafian follicles. The lesions in the anterior hypothalamus seemed to interfere with the release of LH. By present thinking it is likely that the secretion of LH continued at a low level but that the reflex arc for acute release at the appropriate time in the cycle was interrupted.

In guinea pigs lesions elsewhere in the hypothalamus produced no impairment of gonadal functions, yet some of the animals did not mate.

Essentially similar findings and somewhat more precise localization of the lesions were reported in rats (Hillarp, 1949). Constant estrus was "consistently" produced by bilateral, relatively large lesions placed immediately anterior and ventral to the paraventricular nucleus, or by smaller, perfectly bilateral, symmetrical lesions within the area between the paraventricular nucleus and the stalk. Lesions in the dorsal and lateral hypothalamus did not affect the reproductive functions. Eighteen other rats with small lesions variously located in the anterior hypothalamus showed cyclic irregularities and impaired reproductive capacity with essentially normal appearing ovaries. Other more recent studies uniformly emphasize the harmful effect of lesions in the ventral hypothalamus and especially in the median eminence on the reproductive functions of the rat (McCann, 1953; Bogdanove and Halmi, 1953); man (Anderson, Haymaker and Rappaport, 1950); cat (Laqueur, McCann, Schreiner, Rosenberg, Rioch and Anderson, 1955); sheep (Clegg, Santolucito, Smith and Ganong, 1958).

Although lesions in the median eminence often produce some damage to the portal circulation, the infrequency of infarction in the anterior lobe and the usual retention of normal morphologic aspects of this gland make it unlikely that the observed deficiencies in gonadotrophic functions are ascribable to an inadequate vascular supply. It is becoming increasingly evident that the separate trophic functions of the anterior lobe can be selectively altered by appropriately placed lesions in the hypothalamus. The relationship of hypothalamic lesions to the thyrotrophic and adrenotrophic activities of the pituitary need not be considered here, because these seem to be independent mechanisms and exhibit no significant overlap with gonadal regulation. Evidence for the selective effect of localized hypothalamic lesions on pituitary trophic secretions has been presented by Bogdanove and Halmi (1953), Bogdanove, Spirtos and Halmi (1955), Ganong, Fredrickson and Hume (1955), and Bogdanove (1957). It

seems moreover, that such lesions may also selectively influence the individual gonadotrophins, and recently evidence has been provided that lesions in the ventral hypothalamus of sheep may abolish the behavioral manifestations of estrus without altering the ovarian cycle (Clegg, Santolucito, Smith and Ganong, 1958).

The study by Bogdanove and Halmi (1953) also confirms an observation noted by others (Deselin, 1942; May and Stutinsky, 1947; Stutinsky, Bonvallet and Dell, 1950) that lesions in the hypothalamus may lead to a considerable hypertrophy of the pars intermedia. Furthermore, Stutinsky, Bonvallet and Dell (1950) observed great enlargement of the sinusoids in the pars distalis following suitably placed hypothalamic lesions, and speculated that one means of hypothalamic mediation of hypophyseal function might be by way of vasomotor control of vessels in the pars distalis. As a *modus operandi* this has the drawbacks of nonspecificity and sluggishness. The view has not been given credence, but the observation merits study.

#### 4. *Transection of the Hypophyseal Stalk*

An obvious experimental procedure in studying the extent of any control that the hypothalamus may impose on the anterior hypophysis is to interrupt all anatomic connections between them. This has been accomplished by either surgically transecting the stalk or occluding it with a silver clip. In either event the neural and vascular connections between the hypophysis and the brain are disrupted. Such procedures do, in fact, isolate the hypophysis from every possible anatomical connection with the brain, save that of the systemic blood stream. Roundabout as the latter would be, even this avenue is available only in animals having a collateral blood supply to the anterior lobe. Present evidence indicates that this would include man and, with less certainty, monkey, dog, sheep, and rabbit. A consideration of primary importance in all surgical transections of the stalk concerns the demonstrated capacity of the disrupted vessels to regenerate and reestablish vascular connections. Harris (1936-1955), Harris and Jacobsen (1952) and Harris and Johnson (1950) have taken the precaution

of placing a plate of impervious material between the severed ends of the stalk as a barrier to the regrowth of vessels. The severed neurons with nuclei in the hypothalamic ganglia undergo Wallerian degeneration.

Variations exist between species in the length of the pituitary stalk and in the anatomic relationship of the hypophysis to the base of the brain; consequently, it is often possible to divide the stalk at different levels, *i.e.*, near the base of the brain (high) or near the pituitary (low). In those species, especially the rabbit, monkey, and man, which have a deep sella turcica and a relatively long infundibular stem, there is the likelihood that with high transection, portions of the portal circulation may remain intact. Man in particular is held to have a collateral blood supply to the pars distalis (Xuereb, Prichard and Daniel, 1954a, b) by way of the trabecular and the inferior hypophyseal arteries.

The level of stalk transection is also known to be important in terms of the diabetes insipidus which follows this operation. Severance in a plane near the hypophysis in rats (as many have already demonstrated) may result in only a moderate and transient polyuria, whereas after transection in a more proximal plane the polyuria is more often severe and permanent. A plausible explanation of these results is that after low transection, there occurs a compensatory development of neural lobe tissue at the proximal end of the severed stalk. Suprasellar reorganization of neurohypophyseal tissue and restitution of neurohypophyseal functions have been described by Stutinsky (1951, 1953) and confirmed by Billenstien and Leveque (1955) and Benson and Cowie (1956) after hypophysectomy in the rat. Gaupp and Spatz (1955) described compensatory development of a "suprasellar hypophysis" on the tuber cinereum following low transection of the stalk in rabbits. They found these growths to be composed of fibers rich in Gomori-positive granules. Some of the rabbits bearing such nodules came into late sexual maturity, which led the authors to surmise that these compensatory neural elements were providing gonadotrophic stimulation. The nodules they described are of

great interest, but the imputation with respect to gonadotropic functions is weak. No glandular parenchyma was found in the nodules. Moreover the rabbit's own pituitary, although isolated, remained *in situ* and, according to the authors, was undamaged in cytoarchitecture.

Stalk transection has led to extremely discordant findings with regard to the post-operative structure and function of the pars distalis, particularly in the earlier studies. In Dandy's (1940) often cited case of stalk transection in a young adult woman, the reproductive functions were not impaired and no symptoms of hypophysal deficiency appeared, except a severe and permanent diabetes insipidus. Recently Russell (1956) and Eckles, Elmi and Kirschbaum (1958) observed varying but generally severe necrosis of the anterior lobe following stalk severance in man. The menstrual cycles ceased, and there was a notable regression of the gonads, adrenals, and thyroids; an increase in insulin sensitivity suggested a low output of somatotrophin as well. Quite unexpectedly either spontaneous lactation ensued or established milk flow persisted, suggesting output of LTH (*vide infra*). Russell and Eckles, and Elmi and Kirschbaum agreed that the extent of damage to the anterior lobe is associated with the level of stalk transection, this being most severe with low transection. Since in Dandy's patient the stalk was sectioned near the midpoint, it seems likely that the maintenance of the anterior pituitary functions he describes is explicable on the basis that a portion of the circulation to the pars distalis escaped damage. The fact that Russell's patients did not exhibit diabetes insipidus is in all probability attributable to extreme infarction of the anterior lobe and the poor state of the surviving fragments of this tissue.

Brooks (1938) found that stalk-transected rabbits, after a period of transitory gonadal regression, had normal appearing pituitaries and ovaries. These animals came into estrus and mated but failed to ovulate. He presumed that the operation had interfered with the LH-releasing mechanism. Others, too, in acute experiments have fully substantiated the fact that the postcoital ovulation in rabbits requires the presence

of an intact stalk (Westman and Jacobsohn, 1940; Brooks, Beadenkopf and Bojar, 1940). In stalk-transected rabbits which have been observed over protracted periods, extensive gonadal atrophy has usually supervened (Harris, 1937; Westman and Jacobsohn, 1940; Gaupp and Spatz, 1955). Nine of the 12 rabbits operated upon by Gaupp and Spatz showed extreme atrophy of the gonads and genitalia. The remaining 3 reached sexual maturity only after a delay of up to 1½ years.

Much of the pioneering work on stalk transection or occlusion in relation to adeno-hypophysal function was done in dogs (Paulesco, 1908; Crowe, Cushing and Homans, 1910; Cushing and Goetsch, 1910) and monkeys (Karplus and Kriedl, 1910; Morawski, 1911). Cushing and his co-workers observed marked anterior lobe degeneration, and few of their dogs escaped "cachexia hypophysiprivia." In their words, "the resultant condition is almost the same as if this portion of the gland had actually been removed and then reimplanted like a graft, for the circulation is almost entirely cut off." These observations were thoroughly confirmed by Mahoney and Sheehan (1936) in 20 dogs with stalks occluded. Extensive infarction and central necrosis of the pars distalis with concomitant impairment of function was seen in all. Later workers, however, have observed very different sequelae: Keller and Hamilton (1937) and Breckenridge and Keller (1948) found no deviations from the normal patterns of sexual functions in the majority of their stalk-sectioned dogs. The results in dogs must yet be regarded as inconclusive, inasmuch as regeneration of the portal vessels was not adequately controlled and the operation is a difficult one, which, at best, involves an indeterminate amount of trauma to the hypophysal and median eminence areas.

Results have been more consistent in monkeys. Karplus and Kriedl (1910) and Morawski (1911) observed no untoward symptoms in stalk-transected monkeys and no obvious alteration in the histologic structure of the pars distalis; and Mahoney and Sheehan (1936) completely occluded the stalk in 20 monkeys with the same results, including no polyuria or polydipsia. At

autopsy 3 days to 10 months later the hypophyses appeared normal and the vascularity of the anterior lobes was unimpaired, as shown by perfusion with carmine gelatin. These early findings have been substantiated by Harris and Johnson (1950), who made a suprasellar transection of the stalk in a large male monkey. This animal continued to ejaculate, and at the time of autopsy 89 days later the reproductive organs were normal in size and appearance. At autopsy the pars distalis appeared well vasculated and showed no abnormality in size or color. It was demonstrated that vascular continuity between the median eminence and the adenohypophysis had been re-established. From these particular observations one can deduce only that the severance of the neural connections to the hypothalamus are not important for the continuance of adenohypophyseal activity. Disturbance of posterior lobe functions was not observed; this probably is accounted for by the fact that sufficient terminations of neurosecretory fibers exist proximal to the cut to sustain neurohypophyseal functions.

As far as the guinea pig and rat are concerned, the widest possible divergence in results has been reported. In female stalk-sectioned guinea pigs Dempsey (1939) and Leininger and Ranson (1943) observed normal, lengthened, or absent estrous cycles. Tang and Patton (1951) severed the stalk in male guinea pigs and observed no gonadal atrophy. Their animals were maintained for 27 to 75 days, and although the portal vessels could have regenerated postoperatively, no verification of this was found on histologic examination of the region. Equally variable responses have been described in stalk-sectioned rats by Dempsey and Uotila (1940) and Dempsey and Searles (1943). They ascribed the abnormal cycles in such operated animals to operative trauma to the anterior pituitary. Using a parapharyngeal approach for sectioning the stalk in male and female rats, Barnett and Greep (1951) and Greep and Barnett (1951) found a very high incidence of severe gonadal atrophy along with generalized evidence of panhypopituitarism. These symptoms of anterior lobe dysfunction were consonant with the extensive infarction and necrosis of the pars distalis observed regularly following

the operation. They felt that the degree of gonadal dysfunction was relatable to the extent of damage to the blood supply of the pars distalis. The pituitaries showed no capacity for recovery, and there was no regeneration of the portal vessels as determined in specimens injected with India ink and studied in serial sections of the appropriate areas. Years before, Houssay and Giusti (1930) and Lascano-González (1935) had reported on similar infarctions in toads following severance of the vessels to the pars distalis.

Much recent evidence has revealed that vascular infarction, necrosis, and dysfunction of the pars distalis are consequences of procedures which destroy the portal vessels. Daniel and Prichard (1956) studied the degree and localization of vascular lesions in the pars distalis of rats following the application of a fine cautery to all or a portion of the long hypophyseal portal vessels which pass down the ventral aspect of the stalk. Regions of the anterior lobe supplied by short portal vessels emanating from the lower portion of the neural stalk were undamaged. In an extension of their study of the vascular supply to the pituitary, Daniel and Prichard (1957a, b) observed in sheep that severing the stalk produced extensive necrosis of the anterior pituitary; the condition of the pituitary-dependent endocrine organs was not reported. The extent of damage to the pars distalis was remarkably similar to that seen in human cases of postpartum pituitary infarction.

Harris (1949) suggested that the discrepancies in findings following sectioning of the stalk might be reconciled by a study of the extent of regeneration of the portal vessels. Using a transtemporal approach, he sectioned the stalk in a series of rats, killed them at close intervals, and injected the vessels. He demonstrated that the portal vessels unquestionably regenerated in "many cases" and that the regeneration was underway by 24 to 48 hours. In a follow-up study Harris (1950) inserted between the severed ends of the stalk an impervious plate of varying composition. Results were judged by the effect on the estrous cycle. He concluded that the regeneration of portal vessels correlated with the ability of the pars distalis to sustain cyclic gonadal func-

tions. The fact that the pars distalis in rats receives its blood from the portal veins and that regeneration of these vessels means restoration of nutrient supply to this organ, would seem, on the face of it, to be a plausible explanation for resumption of secretory activity following stalk transection. However, there is strong evidence against this possibility. Grafts of the pituitary gland revascularized by vessels from other than the median eminence lose their ability to sustain ovarian functions other than progestational (Harris and Jacobsohn, 1952; Everett, 1954, 1956; Nikitovitch-Winer and Everett, 1957), and regain these functions when vascular continuity with the median eminence is restored (Nikitovitch-Winer and Everett, 1957, 1958a, b).

A series of recent reports has dealt with the capacity of stalk-sectioned ferrets to respond to the stimulus of added illumination. Thomson and Zuckerman (1953, 1954) and Zuckerman (1955) claimed that estrus supervened in 10 of 16 operated ferrets exposed to added illumination. In two of the animals which responded, careful study of serial sections of the operative site after India ink perfusion revealed no vascular connections between the pituitary and the median eminence. Thus, the essentiality of the portal vessels and whatever humors they might convey for the regulation of adenohypophyseal activities was called into question. Donovan and Harris (1956), on the contrary, found that stalk-transected ferrets in which regeneration of the portal vessels was precluded by a film barrier between the severed ends of the stalk did not exhibit light-induced estrus; 3 animals lacking the barrier responded with early estrus, but in each of them regeneration of a vascular link with median eminence was demonstrated. The question left unanswered by the latter experiments is whether the pituitaries in the animals which did not respond actually had the capacity to respond. Collateral evidence, such as reduced adrenal weight and decreased thyroid activity, suggests that the pituitaries may have been functionally incapacitated for reasons other than lack of a specific excitatory agent of hypothalamic origin. Campbell and Harris (1957) addressed themselves to this problem by studying the volume change of

the rabbit pituitary after dividing the stalk. They found a reduction to 62-74 per cent of the normal volume for the whole gland, 68-83 per cent for the pars distalis, and 26-27 per cent for the neural lobe. Because the extent of atrophy in operated animals was the same with or without plate insertion, they questioned the importance of ischemic damage. The rabbit, however, seems an unfortunate choice for study of this problem because Harris (1947) had already noted that the anterior lobe in this species has an arterial as well as a portal venous blood supply. Moreover, volume changes are not a crucial index of glandular competence. Breckenridge and Keller (1948) found no correlation between retention of sex functions and the size of the anterior lobe remnant in dogs which had been subjected to complete removal of the stalk and partial (graded) hypophysectomy. There was, however, a close correlation between maintenance of the genital structures and retention of normal cytoarchitecture of the remnant.

The arrangement of nervous and vascular connections between the pituitary and the brain in birds is such that it is possible to section the infundibular stalk, leaving the portal vessels intact, or contrariwise, divide the vessels leaving the stalk undamaged, or by appropriate incision segregate the median eminence from the hypothalamus without disturbing either the portal vessels or the stalk. These experimental procedures have been carried out on the duck (Benoit and Assenmacher, 1953; Assenmacher and Benoit, 1953a, b). Stalk transection alone did not alter gonadal maturation in animals exposed to added illumination, but the response was completely blocked by sectioning either the median eminence or the anterior portal vessels; in birds these vessels supply the cephalic lobe of the pars distalis. In spite of the impaired secretion of gonadotrophins, the functional capacity of the anterior lobe tissue was otherwise adequate as evidenced by the fact that the thyroids and adrenals were fully maintained. After severing both stalk and portal vessels in laying hens, Shirley and Nalbandov (1956a, b) observed gonadal atrophy, but no change in either the thyroids or adrenals. Benoit and his associates and Shirley and Nalbandov strongly favor the

interpretation that hypothalamic agents are involved in the excitation of the hypophysis to secrete gonadotrophic hormones.

Mention has been made of the interesting preliminary observation by Eckles, Ehni and Kirschbaum (1958) of persistent lactation as a sequel to stalk transection in women with breast cancer. (Polyethylene plates were inserted between the cut ends of the stalk.) In some women lactation was observed to continue for a year or longer. The menses ceased, hence it can be assumed that the secretion of FSH and LH was interrupted. Why then, was the secretion of LTH not also abated? It seems pertinent also to note here that galactorrhea has frequently been seen in female mammals and patients receiving tranquilizing drugs (Kehl, Audebert, Gage and Amarger, 1956; Polishuk and Kulesar, 1956; Whitelaw, 1956; Meites, 1957; Sawyer, 1957). It would seem, in fact, that an inhibiting influence on LTH secretion had been removed by these procedures. These findings in man parallel the observations by Desclin (1950) and Everett (1954, 1956) that autografts of the pars distalis to the renal capsule secrete LTH selectively, and perhaps in increased quantities for several months (see also Nikitovitch-Winer and Everett, 1957, 1958a, b for further variants of this study of pituitary autografts). Perhaps the fact that pseudopregnancy often supervenes in rats under continued treatment with certain tranquilizing agents (Barraclough, 1957; Velardo, 1958; Barraclough and Sawyer, 1959) can be explained by an abnormal release of LTH from the pars distalis. Inherent in this evidence is the suggestion that the hypothalamus exercises either no influence or a "tonic" suppressive influence on the secretion of LTH by the pars distalis. Other recent evidence suggests, however, that the hypothalamus may also supply a stimulus for the release and possibly the production of prolactin (LTH). Oxytocin, a neurohypophysial hormone that is almost certainly elaborated in the hypothalamus (Scharrer and Scharrer, 1945, 1954a, b; Bargmann, 1949; Olivecrona, 1957), has been shown to lead to structural maintenance of the mammary gland (Benson and Folley, 1956, 1957). The resolution of such an interesting but bafflingly complex

hypothalamo-hypophysial interrelationship must await much additional experimentation.

## VI. References

- ABRAMOWITZ, A. A., AND HISAW, F. L. 1939. The effects of proteolytic enzymes on purified gonadotrophic hormones. *Endocrinology*, **25**, 633-637.
- ABRAMS, M. E., MARSHALL, W. A., AND THOMSON, A. P. D. 1954. Effect of cervical sympathectomy at the onset of estrus in ferrets. *Nature*, London, **174**, 311.
- ADAMS, A. E., AND GRANGER, B. 1941. Further study of effects of administering anterior pituitaries to immature female mice. *Am. J. Anat.*, **69**, 229-263.
- ADDIS, T., AND LEW, W. 1940. The restoration of lost organ tissue: the rate and degree of restoration. *J. Exper. Med.*, **71**, 325-333.
- ALLISON, R. M. 1954. Reduced maintenance of frogs used for pregnancy diagnosis by enforced hibernation. *J. Endocrinol.*, **11**, 377-379.
- AMOROSO, E. C., AND MATTHEWS, L. H. 1955. The effect of external stimuli on the breeding cycle of birds and mammals. *Brit. M. Bull.*, **11**, 87-192.
- ANDERSON, E., AND HAYMAKER, W. 1948a and b. Influence of hypothalamus on sexual function. *J. A. M. Women's A.*, **3**, 102, 457-461.
- ANDERSON, E., HAYMAKER, W., AND RAPPAPORT, H. 1950. Semiferrous tubule failure associated with degenerative change in the hypothalamus. A clinicopathologic report of a case of reactive gliosis of the floor of the third ventricle. *Am. Pract. & Digest Treat.*, **1**, 40-45.
- ANDERSSON, B. 1951a. The effect and localization of electrical stimulation of certain parts of the brain stem in sheep and goats. *Acta physiol. scandinav.*, **23**, 8-23.
- ANDERSSON, B. 1951b. Further studies on the milk ejection mechanism in sheep and goats. *Acta physiol. scandinav.*, **23**, 24-30.
- ASDELL, S. A. 1924. Some effects of unilateral ovariectomy in rabbits. *Brit. J. Exper. Biol.*, **1**, 473-486.
- ASSEMACHIER, L., AND BENOIT, J. 1953a. Contribution à l'étude des relations de la substance Gomoripositive avec le complexe hypophysaire et la gonadostimulation chez le canard domestique. *Compt. rend. acad. sc.*, **236**, 133-135.
- ASSEMACHIER, L., AND BENOIT, J. 1953b. Répercussions de la section du tractus portotubéral hypophysaire sur la gonadostimulation par la lumière chez le Canard domestique. *Compt. rend. acad. sc.*, **236**, 2002-2004.
- ASTWOOD, E. B. 1939a. An assay method for progesterone based upon decidual reaction in the rat. *J. Endocrinol.*, **1**, 49-55.
- ASTWOOD, E. B. 1939b. Changes in the weight and water content of the uterus of the normal adult rat. *Am. J. Physiol.*, **126**, 162-170.
- ASTWOOD, E. B. 1941. The regulation of corpus luteum function by hypophysial luteotrophin. *Endocrinology*, **28**, 309-320.



- ASTWOOD, E. B. 1953. Tests for luteotrophin. Ciba Foundation Colloquia, *Endocrinol.*, **5**, 74-85.
- ATZ, E. H., AND PICKFORD, G. E. 1954. Failure to elicit the Galli-Mainini reaction in *Rana pipiens* with spawning reflex fractions and other teleostean pituitary preparations, and observations on the response to mammalian gonadotrophins. *Zoologica*, **39**, 117-122.
- BACHMAN, C. 1935. Oestrogenic hormone and mechanism of corpus luteum formation in rabbit. *Proc. Soc. Exper. Biol. & Med.*, **33**, 551-554.
- BAHN, R. C., LORENZ, N., BENNETT, W. A., AND ALBERT, A. 1953a. Gonadotropins of the pituitary gland and the urine of the adult human female. *Endocrinology*, **52**, 135-139.
- BAHN, R. C., LORENZ, N., BENNETT, W. A., AND ALBERT, A. 1953b. Gonadotropins of the pituitary gland during infancy and early childhood. *Endocrinology*, **52**, 605-606.
- BAHN, R. C., LORENZ, N., BENNETT, W. A., AND ALBERT, A. 1953c. Gonadotropins of the pituitary of postmenopausal women. *Endocrinology*, **53**, 455-457.
- BAHN, R. C., LORENZ, N., BENNETT, W. A., AND ALBERT, A. 1953d. Gonadotropins of the pituitary gland and urine of the adult human male. *Proc. Soc. Exper. Biol. & Med.*, **82**, 777-782.
- BARGMANN, W. 1949. Über die neurosekretorische Verknüpfung von Hypothalamus und Neurohypophyse. *Zschr. Zellforsch. mikroskop. Anat.*, **34**, 610-631.
- BARRACLOUGH, C. A. 1957. Induction of pseudopregnancy in the rat by reserpine and chlorpromazine. *Anat. Rec.*, **127**, 262.
- BARRACLOUGH, C. A., AND SAWYER, C. H. 1959. Induction of pseudopregnancy in the rat by reserpine and chlorpromazine. *Endocrinology*, **65**, 563-571.
- BARNETT, R. J., AND GREEP, R. O. 1951. The direction of flow in the blood vessels of the infundibular stalk. *Science*, **113**, 185.
- BASSETT, E. G., SEWELL, O. K., AND WHITE, E. P. 1955. Sex hormone studies on sheep. *New Zealand J. Sc. Tech. A.*, **36**, 437-449.
- BATES, R. W., RIDDLE, O., AND LAIRH, E. L. 1935. An assay of three hormones present in anterior pituitaries of seven types of cattle classified for age, sex, and stage of reproduction. *Am. J. Physiol.*, **113**, 259-264.
- BENOIT, J. 1936. Stimulation par la lumière de l'activité sexuelle chez le canard et la cane domestiques. *Bull. Biol.*, **70**, 488-533.
- BENOIT, J. 1955. Discussion of R. M. Fraps, The varying effects of sex hormones in birds. *Comparative Physiology of Reproduction, Memoirs of the Society for Endocrinology*, No. 4, p. 219, Chester Jones and Eckstein, Eds. London: Cambridge University Press.
- BENOIT, J., AND ASSENMACHER, I. 1951a. Dispositifs nerveux de l'éminence médiane; leurs rapports avec la vascularisation hypophysaire chez le canard domestique. *Compt. rend. Soc. biol.*, **145**, 1395.
- BENOIT, J., AND ASSENMACHER, I. 1951b. Circulation porte tubero-prehypophysaire chez le canard domestique. *Compt. rend. Soc. biol.*, **145**, 1112-1116.
- BENOIT, J., AND ASSENMACHER, I. 1953. Rapport entre la stimulation sexuelle prehypophysaire et la neurosecretion chez l'oiseau. *Arch. anat. microscop.*, **42**, 324-386.
- BENOIT, J., AND ASSENMACHER, I. 1955. Le contrôle hypothalamique de l'activité prehypophysaire gonadotrope. *J. Physiol.*, Paris, **47**, 427-567.
- BENSON, G. K., AND COWIE, A. T. 1956. Lactation in the rat after hypophysial posterior lobectomy. *J. Endocrinol.*, **14**, 54-65.
- BENSON, G. K., AND COWIE, A. T. 1957. Hormones in reproduction and lactation. *J. Dairy Res.*, **24**, 252-282.
- BENSON, G. K., AND FOLLEY, S. J. 1956. Oxytocin as stimulator for the release of prolactin from the anterior pituitary. *Nature*, London, **177**, 700.
- BENSON, G. K., AND FOLLEY, S. J. 1957. The effect of oxytocin on mammary gland involution in the rat. *J. Endocrinol.*, **16**, 189-204.
- BHADURI, J. L. 1951. The role of salientia in human and mammalian pregnancy tests. Section of Zoology and Entomology, 38th Indian Science Congress, Bangalore.
- BIDDULPH, C., AND MEYER, R. K. 1941. Influence of vitamin E deficiency on endocrine glands of rats, particularly on gonadotrophic hormone content of pituitary gland. *Am. J. Physiol.*, **132**, 259-271.
- BIDDULPH, C., MEYER, R. K., GUMBRECK, L. G. 1940. The influence of estril, estradiol and progesterone on the secretion of gonadotrophic hormones in parabiote rats. *Endocrinology*, **26**, 280-284.
- BILLENSTIEN, D. C., AND LEVEQUE, T. F. 1955. The reorganization of the neurohypophysial stalk following hypophysectomy in the rat. *Endocrinology*, **56**, 704-717.
- BISKIND, M. S. 1946. Nutritional therapy of endocrine disturbances. *Vitamins & Hormones*, **4**, 147-185.
- BISWAL, G., AND NALBANDOV, A. V. 1952. Unpublished data, cited by Kornfeld and Nalbandov, 1954.
- BOGDANOVE, E. M. 1957. Selectivity of the effect of hypothalamic lesions on pituitary trophic hormone secretion in the rat. *Endocrinology*, **60**, 689-697.
- BOGDANOVE, E. M., AND HALMI, N. S. 1953. Effects of hypothalamic lesions and subsequent propylthiouracil treatment on pituitary structure and function in rat. *Endocrinology*, **53**, 274-292.
- BOGDANOVE, E. M., SPIRTOS, B. N., AND HALMI, N. S. 1955. Further observations on pituitary structure and function in rats bearing hypothalamic lesions. *Endocrinology*, **57**, 302-315.
- BOLING, J. L., AND BLANDA, R. J. 1939. Estrogen-progesterone induction of mating response in sprayed female rat. *Endocrinology*, **25**, 359-374.
- BRADBURY, J. T. 1947. Ovarian influence on the

- response of the anterior pituitary to estrogens. *Endocrinology*, **41**, 501-513.
- BRADBURY, J. T., BROWN, W. E., AND GRAY, L. A. 1950. Maintenance of the corpus luteum and physiologic actions of progesterone. *Recent Progr. Hormone Res.*, **5**, 151-194.
- BRADGON, D. E. 1951. The nonessentiality of the corpora lutea for the maintenance of gestation in certain live-bearing snakes. *J. Exper. Zool.*, **118**, 419-435.
- BRAMBELL, F. W. R. 1956. Ovarian changes. In *Marshall's Physiology of Reproduction*, 3rd ed., Vol. I, Pt. I, A. F. Parkes, Ed., pp. 397-512. London: Longmans, Green and Company.
- BRECKENRIDGE, C. G., AND KELLER, A. D. 1948. Retention of sex functions after isolation of the pars anterior by extirpation of the hypophysial stalk. *Am. J. Physiol.*, **152**, 591-597.
- BRENEMAN, W. R. 1936. The effect on the chick of some gonadotropic hormones. *Anat. Rec.*, **64**, 211-220.
- BRENEMAN, W. R. 1942. Action of prolactin and estrone on weights of reproductive organs and viscera of cockerel. *Endocrinology*, **30**, 609-615.
- BRENEMAN, W. R. 1945. The gonadotropic activity of the anterior pituitary of cockerels. *Endocrinology*, **36**, 190-199.
- BRENEMAN, W. R. 1955. Reproduction in birds: the female. In *Comparative Physiology of Reproduction, Memoirs of the Society for Endocrinology*, No. 4, I. Chester Jones and P. Eckstein, Eds. London: Cambridge University Press.
- BRENEMAN, W. R., AND MASON, R. C. 1951. Androgen influence on pituitary-gonad interrelationship. *Endocrinology*, **48**, 752-762.
- BROOKS, C. McC. 1938. A study of the mechanism whereby coitus excites the ovulation-producing activity of the rabbit's pituitary. *Am. J. Physiol.*, **121**, 157-177.
- BROOKS, C. McC., BEADENKOPF, W. G., AND BOJAR, S. 1940. A study of the mechanism whereby copper acetate and certain drugs produce ovulation in the rabbit. *Endocrinology*, **27**, 878-882.
- BROWN, P. S. 1955. The assay of gonadotrophin from urine of nonpregnant human subjects. *J. Endocrinol.*, **13**, 59-64.
- BROWN, P. S. 1956. Follicle stimulating and interstitial cell stimulating hormones in the urine of women with amenorrhoea. *J. Endocrinol.*, **14**, 129-137.
- BROWN, P. S. 1958. Human urinary gonadotrophins. I. In relation to puberty. *J. Endocrinol.*, **17**, 329-336.
- BROWN, P. S. 1959. Human urinary gonadotrophins. II. In relation to the menstrual cycle, secondary amenorrhoea and the response to oestrogen. *J. Endocrinol.*, **18**, 46-55.
- BROWN, J. H. U., AND HESS, M. 1957. Separation of hormonal activities in the anterior pituitary by ultracentrifugation. *Am. J. Physiol.*, **188**, 25-29.
- BRUNER, J. A. 1951. Distribution of chorionic gonadotropin in mother and fetus at various stages of pregnancy. *J. Clin. Endocrinol.*, **11**, 360-374.
- BRYANS, F. E. 1951. Progesterone of the blood in the menstrual cycle of the monkey. *Endocrinology*, **48**, 733-740.
- BUNDE, C. A., AND GREEP, R. O. 1936. Suppression of persisting corpora lutea in hypophysectomized rats. *Proc. Soc. Exper. Biol. & Med.*, **35**, 235-237.
- BURGER, J. W., BISSONNETTE, T. H., AND DOOLITTLE, H. D. 1942. Some effects of flashing light on testicular activation in the male starling (*Sturnus vulgaris*). *J. Exper. Zool.*, **90**, 73-82.
- BURROWS, H. 1949. *Biological Actions of Sex Hormones*, 2nd ed. Cambridge, Mass.: University Press.
- BURT, A. S., AND VELARDO, J. T. 1954. Cytology of human hypophysis as related to bioassays for tropic hormones. *J. Clin. Endocrinol.*, **14**, 979-996.
- BYERLY, T. C., AND BURROWS, W. H. 1938. Chick testis weight response to gonadotropic hormone. *Endocrinology*, **22**, 366-369.
- BYRNES, W. W., AND MEYER, R. K. 1951a. The inhibition of gonadotropic hormone secretion by physiologic doses of estrogen. *Endocrinology*, **48**, 133-136.
- BYRNES, W. W., AND MEYER, R. K. 1951b. Effect of physiological amounts of estrogen on the secretion of follicle stimulative and luteinizing hormone. *Endocrinology*, **49**, 449-460.
- BYRNES, W. W., AND SHIPLEY, E. G. 1950. Estrogenic and gonadotropic hormone inhibiting activity of some adrenal cortical substances. *Proc. Soc. Exper. Biol. & Med.*, **74**, 308-310.
- CAHANE, M., AND CAHANE, T. 1935. Sur certaines modifications de l'hypophyse après une lésion du contre infundibulaire régulateur de la fonction génitale. (Note préliminaire.) *Rev. franç. endocrinol.*, **13**, 366-371.
- CAHANE, M., AND CAHANE, T. 1936. Sur certaines modifications des glandes endocrines après une lésion diencéphalique. *Rev. franç. endocrinol.*, **14**, 472-487.
- CAMPBELL, H. J., AND HARRIS, G. W. 1957. The volume of the pituitary and median eminence in stalk-sectioned rabbits. *J. Physiol.*, **136**, 333-343.
- CARLISLE, D. B. 1950. Gonadotrophin from the neural region of ascidians. *Nature*, London, **166**, 737.
- CARLISLE, D. B. 1951. The effect of mammalian lactogenic hormone on lower chordates. *J. Marine Biol. Ass. United Kingdom*, **33**, 65-68.
- CARMICHAEL, E. S., AND MARSHALL, F. H. A. 1908. On the occurrence of compensatory hypertrophy in the ovary. *J. Physiol.*, **36**, 431-434.
- CASIDA, L. E., MEYER, R. K., McSHAN, W. H., AND WISNICKY, W. 1943. Effects of pituitary gonadotrophins on ovaries and induction of superfecundity in cattle. *Am. J. Vet. Res.*, **4**, 76-94.
- CASIDA, L. E., WARWICK, E. J., AND MEYER, R. K. 1944. Survival of multiple pregnancies induced in the ewe following treatment with

- pituitary gonadotropins. *J. Animal Sci.*, **3**, 22-28.
- CHANCE, M. R. A., ROWLANDS, I. W., AND YOUNG, F. G. 1939. Species variation in thyrotrophic, gonadotropic, and prolactin activities of anterior hypophyseal tissue. *J. Endocrinol.*, **1**, 239-260.
- CHANG, M. C. 1947a. Normal development of fertilized rabbit ova stored at low temperature for several days. *Nature*, London, **159**, 602.
- CHANG, M. C. 1947b. Transplantation of fertilized rabbit ova: the effect on viability of age, *in vitro* storage period, and storage temperature. *Nature*, London, **161**, 978.
- CHEN, G., AND VAN DYKE, H. B. 1939. Gonadotropic action of anterior pituitary extract after tryptic digestion. *Proc. Soc. Exper. Biol. & Med.*, **40**, 172-176.
- CHESTER JONES, I. 1949. Relationship of mouse adrenal cortex to the pituitary. *Endocrinology*, **45**, 514-536.
- CHESTER JONES, I. 1950. Effect of hypophysectomy on adrenal cortex of immature mouse. *Am. J. Anat.*, **86**, 371-401.
- CHESTER JONES, I. 1955. Role of the adrenal cortex in reproduction. *Brit. Med. Bull.*, **11**, 156-158.
- CHESTER JONES, I. 1957. *The Adrenal Cortex*. London: Cambridge University Press.
- CHESTER JONES, I., AND ECKSTEIN, P. 1955. *Comparative Physiology of Reproduction. Memoirs of the Society for Endocrinology*, No. 4. London: Cambridge University Press.
- CHOW, B. F. 1942. Gonadotropins of the swine pituitary. *Endocrinology*, **30**, 657-661.
- CHOW, B. F., GREEP, R. O., AND VAN DYKE, H. B. 1939. Effects of digestion by proteolytic enzymes on gonadotrophic and thyrotrophic potency of anterior pituitary extract. *J. Endocrinol.*, **1**, 440-469.
- CHOW, B. F., VAN DYKE, H. B., GREEP, R. O., ROTHEN, A., AND SNEDELOVSKY, T. 1942. Gonadotropins of the swine pituitary. II. Preparation, and biological and physicochemical characterization of a protein apparently identical with metakentrin (ICSH). *Endocrinology*, **30**, 650-656.
- CHRIST, J. 1951. Zur anatomie des tuber cinereum beim erwachsenen menschen. *Deutsche Ztschr. Nervenh.*, **165**, 340-408.
- CLARK, H. M. 1935a. A prepubertal reversal of the sex difference in the gonadotropic hormone content of the pituitary gland of the rat. *Anat. Rec.*, **61**, 175-192.
- CLARK, H. M. 1935b. A sex difference in the change in potency of the anterior hypophysis following bilateral castration in newborn rats. *Anat. Rec.*, **61**, 193-202.
- CLARKE, P. M., AND FOLLEY, S. J. 1953. Some observations on prolactin assays by the pigeon crop-weight method. *Ciba Foundation Colloquia Endocrinol.*, **5**, 90-103.
- CLAUSEN, H. J. 1940. Studies on the effect of ovariectomy and hypophysectomy on gestation in snakes. *Endocrinology*, **27**, 700-704.
- CLEGG, M. T., SANTOLUCITO, J. A., SMITH, J. D., AND GANONG, W. F. 1958. The effect of hypothalamic lesions on sexual behavior and estrous cycles in the ewe. *Endocrinology*, **62**, 790-797.
- CONSTANTINIDES, P. 1947. Progesterone secretion during the oestrous cycle of the unmated rat. *J. Endocrinol.*, **5**, lxiv.
- COWIE, A. T., AND FOLLEY, S. J. 1955. Physiology of the gonadotropins and the lactogenic hormone. In *The Hormones*, Vol. 3. Pincus and Thimann, Eds. New York: Academic Press, Inc.
- COZENS, D. A., AND NELSON, M. M. 1958. Increased follicle-stimulating activity in the plasma of ovariectomized rats. *Proc. Soc. Exper. Biol. & Med.*, **98**, 617-620.
- CREASER, C. W., AND GORBIAN, A. 1939. Species specificity of the gonadotropic factors in vertebrates. *Quart. Rev. Biol.*, **14**, 311-331.
- CRÉZÉ, J. 1949. Diagnostic biologique de la grossesse par le test des batraciens mâles communs en France. *Rev. franç. Gynec. Obst.*, **44**, 53-56.
- CROOKE, A. C. 1952. Discussion of J. D. Green's Comparative aspects of the hypophysis, especially of blood supply and innervation. *Ciba Foundation Colloquia Endocrinol.*, **4**, 86.
- CROSS, B. A., AND HARRIS, G. W. 1950. Milk ejection following electrical stimulation of the pituitary stalk in rabbits. *Nature*, London, **166**, 994.
- CROSS, B. A., AND HARRIS, G. W. 1951. The neurohypophysis and let-down of milk. *J. Physiol.*, London, **113**, 35.
- CROWE, S. J., CUSHING, H., AND HOMANS, J. 1910. Experimental hypophysectomy. *Bull. Johns Hopkins Hosp.*, **21**, 127-169.
- CUSHING, H., AND GOETSCH, E. 1910. Concerning the secretion of the infundibular lobe of the pituitary body and its presence in the cerebrospinal fluid. *Am. J. Physiol.*, **27**, 60-86.
- CUTLY, E. 1941. Implantation following mating in hypophysectomized rats injected with lactogenic hormone. *Proc. Soc. Exper. Biol. & Med.*, **48**, 315-318.
- CUTLY, E. 1942. Effects of lactogenic and gonadotropic hormones on hypophysectomized pregnant rats. *Endocrinology*, **31**, 13-22.
- CUTLY, E., AND CUTLY, E. C. 1938. Inhibition of gonadotropic activity by sex hormones in parabiotic rats. *Endocrinology*, **22**, 568-578.
- CUTLY, E., McCULLAGH, D. R., AND CUTLY, E. C. 1937. Effects of androgenic substances in hypophysectomized rats. *Am. J. Physiol.*, **119**, 121-126.
- DANDY, W. E. 1940. Section of the human hypophysial stalk. *J. A. M. A.*, **114**, 312-314.
- DANIEL, P. M., AND PRICHARD, M. M. L. 1956. Anterior pituitary necrosis. Infarction of the pars distalis produced experimentally in the rat. *Quart. J. Exper. Physiol.*, **41**, 215-229.
- DANIEL, P. M., AND PRICHARD, M. M. L. 1957a. The vascular arrangements of the pituitary gland of the sheep. *Quart. J. Exper. Physiol.*, **42**, 237-248.
- DANIEL, P. M., AND PRICHARD, M. M. L. 1957b. Anterior pituitary necrosis in the sheep. 195-

- duced by section of the pituitary stalk. *Quart. J. Exper. Physiol.*, **42**, 248-253.
- DAV, B. C., AND NALBANDOV, A. V. 1955. Responses of ovaries of immature chickens to avian and mammalian gonadotrophins. *Endocrinology*, **57**, 705-710.
- DAVIS, M. E., AND HELLBAUM, A. A. 1944. Observations on experimental use of gonadotropic extracts in human female. *J. Clin. Endocrinol.*, **4**, 400-409.
- DAWSON, A. B. 1939. The occurrence and distribution of a modified acidophile in the anterior pituitary of the female monkey (*Rhesus mucus*). *Anat. Rec.*, **73**, 63-64.
- DAWSON, A. B. 1948. The relationship of pars tuberalis to pars distalis in the hypophysis of the rhesus monkey. *Anat. Rec.*, **102**, 103-121.
- DAWSON, A. B. 1957. Morphological evidence of a possible function interrelationship between the median eminence and the pars distalis of the murine hypophysis. *Anat. Rec.*, **128**, 77-86.
- DE AZEVEDO, P., AND CANALE, L. 1938. A hipófise e sua ação nas gonadas dos peixes neotrópicos. *Arch. Inst. biol. (Def. agric. anim.)*, S. Paulo, **9**, 165-186.
- DE GROOT, J., AND HARRIS, G. W. 1950. Hypothalamic control of anterior pituitary gland and blood lymphocytes. *J. Physiol.*, **111**, 335-346.
- DEMSEY, E. W. 1937. Follicular growth rate and ovulation under various experimental procedures in guinea pigs. *Am. J. Physiol.*, **120**, 126-132.
- DEMSEY, E. W. 1939. Relationship between central nervous system and reproductive cycle in female guinea pig. *Am. J. Physiol.*, **126**, 758-765.
- DEMSEY, E. W., HERTZ, R., AND YOUNG, W. C. 1936. Experimental induction of oestrus (sexual receptivity) in normal and ovariectomized guinea pig. *Am. J. Physiol.*, **116**, 201-209.
- DEMSEY, E. W., AND SEARLES, H. F. 1943. Environmental modification of certain endocrine phenomena. *Endocrinology*, **32**, 119-128.
- DEMSEY, E. W., AND UOTILA, U. U. 1940. The effect of pituitary stalk section upon reproductive phenomena in the female rat. *Endocrinology*, **27**, 573-579.
- DESCLIN, L. 1942. Influence de la section de la tige hypophysaire sur le lobe moyen de l'hypophyse. *Acta biol. belg.*, **2**, 376-379.
- DESCLIN, L. 1949. Observations sur la structure des ovaires chez des rats soumis à l'influence de la prolactine. *Ann. endocrinol.*, **10**, 1-18.
- DESCLIN, L. 1950. A propos du mécanisme d'action des oestrogènes sur le lobe antérieur de l'hypophyse chez le rat. *Ann. endocrinol.*, **11**, 656-659.
- DESCLIN, L. 1956a. L'ocytocine peut-elle déclencher la libération de l'utérotrépine hypophysaire chez le rat? *Compt. rend. Soc. biol.*, **150**(7): 1489-1491.
- DESCLIN, L. 1956b. Hypothalamus et libération d'hormone lutéotrophique. Expériences de greffe hypophysaire chez le rat hypophysectomisé. Action lutéotrophique de l'ocytocine. *Ann. endocrinol.*, **17**, 586-595.
- DEY, F. L. 1941. Changes in ovaries and uteri in guinea pigs with hypothalamic lesions. *Am. J. Anat.*, **69**, 61-87.
- DEY, F. L. 1943a. Evidence of hypothalamic control of hypophysical gonadotropic function in the female guinea pig. *Endocrinology*, **33**, 75-82.
- DEY, F. L. 1943b. Failure to induce ovulation in constant estrous guinea pigs. *Proc. Soc. Exper. Biol. & Med.*, **52**, 312-313.
- DEY, F. L. 1943c. Genital changes in female guinea pigs resulting from destruction of the median eminence. *Anat. Rec.*, **87**, 85-90.
- DEY, F. L., FISHER, C., BERRY, C. M., AND RANSON, S. W. 1940. Disturbances in reproductive functions caused by hypothalamic lesions in female guinea pigs. *Am. J. Physiol.*, **129**, 39-46.
- DEY, F. L., LEININGER, C. R., AND RANSON, S. W. 1942. Effect of hypophysial lesions on mating behavior in female guinea pigs. *Endocrinology*, **30**, 323-326.
- DODD, J. M. 1955. The hormones of sex and reproduction and their effects in fish and lower chordates. In *Comparative Physiology of Reproduction, Memoirs of the Society for Endocrinology*, No. 4. I. Chester Jones and P. Eckstein, Eds. London: Cambridge University Press.
- DONKER, J. D., KOSHI, J. H., AND PETERSEN, W. E. 1954. The effect of exogenous oxytocin in blocking the normal relationship between endogenous oxytocic substance and the milk ejection phenomenon. *Science*, **119**, 67-68.
- DONOVAN, B. T., AND HARRIS, G. W. 1956. The effect of pituitary stalk section on light-induced oestrus in the ferret. *J. Physiol.*, **131**, 102-114.
- DONOVAN, B. T., AND VAN DER WERFF TEN BOSCH, J. J. 1956. The cervical sympathetic system and light-induced oestrus in the ferret. *J. Physiol.*, **132**, 123-129.
- DOWLING, D. F. 1949. Problems of the transplantation of fertilized ova. *J. Agric. Sc.*, **39**, 374-396.
- DRILL, V. A., AND BURRILL, M. W. 1944. Effect of thiamin deficiency and controlled inanition on ovarian function. *Endocrinology*, **35**, 187-192.
- DRUMMOND, J. C., NOBLE, R. L., AND WRIGHT, M. D. 1939. Studies on relationship of vitamin E (tocopherols) to endocrine system. *J. Endocrinol.*, **1**, 275-286.
- DUNHAM, L. J., WATTS, R. M., AND ADAIR, F. L. 1941. Development of newborn rat ovaries implanted in the anterior chambers of adult rats' eyes. *Arch. Pathol.*, **32**, 910-927.
- DURY, A., AND BRADBURY, J. T. 1942. Copper-induced pseudopregnancy in the adult estrous rat. *Am. J. Physiol.*, **135**, 587-590.
- DUTT, R. H. 1953. The role of estrogens and progesterone in ovulation. *Iowa State Coll. J. Sc.*, **28**, 55-56.
- DUTT, R. H., AND CASIDA, L. E. 1948. Alteration

- of the estrual cycle in sheep by use of progesterone and its effect upon subsequent ovulation and fertility. *Endocrinology*, **43**, 208-217.
- DVOSKIN, S. 1947. Reinitiation of spermatogenesis by pellets of testosterone and its esters in hypophysectomized rats. *Anat. Rec.*, **99**, 329-352.
- DVOSKIN, S. 1949. The effect of pregnenolone on reinitiation and maintenance of spermatogenesis in hypophysectomized rats. *Endocrinology*, **45**, 370.
- EAYRS, J. T., AND BADDELEY, R. M. 1956. Neural pathways in lactation. *J. Anat.*, London, **90**, 161-171.
- ECKLES, N. E., EHNI, G., AND KIRSCHBAUM, A. 1958. Induction of lactation in the human female by pituitary stalk-section. *Anat. Rec.*, **130**, 295.
- EDWARDS, J. 1940. The effect of unilateral castration on spermatogenesis. *Proc. Roy. Soc.*, London, ser. B, **128**, 407-421.
- ELDER, W. H., AND FINERTY, J. C. 1943. Gonadotropic activity of the pituitary gland in relation to the seasonal sexual cycle of the cottontail rabbit (*Sylvilagus floridanus neausi*). *Anat. Rec.*, **85**, 1-16.
- ELLIS, S. 1958. A scheme for the separation of pituitary proteins. *J. Biol. Chem.*, **233**, 63-68.
- EMERSON, G. A., AND EVANS, H. M. 1940. Growth and reproductive physiology in vitamin B<sub>6</sub> deficiency. *Am. J. Physiol.*, **129**, 352.
- EMERY, F. E. 1932. The anterior pituitary sex hormone in the blood and urine of rats. *Am. J. Physiol.*, **101**, 246-250.
- ERSHOFF, B. H. 1943. Degeneration of corpora lutea in pregnant vitamin E-deficient rat. *Anat. Rec.*, **87**, 297-301.
- ERSHOFF, B. H. 1952. Nutrition and the anterior pituitary with special reference to the general adaptation syndrome. *Vitamins & Hormones*, **10**, 79-140.
- EVANS, H. M., AND SIMPSON, M. E. 1940. Experimental superfecundity with pituitary gonadotrophins. *Endocrinology*, **27**, 305-308.
- EVANS, H. M., AND SIMPSON, M. E. 1950. Physiology of the gonadotrophins. In *The Hormones*, Vol. 2, G. Pincus and K. V. Thimann, Eds. New York: Academic Press, Inc.
- EVANS, H. M., SIMPSON, M. E., AND LYONS, W. R. 1941. Influence of lactogenic preparations on production of traumatic placentoma in rat. *Proc. Soc. Exper. Biol. & Med.*, **46**, 586-590.
- EVANS, H. M., SIMPSON, M. E., LYONS, W. R., AND TURPELIX, K. 1941. Anterior pituitary hormones which favor production of traumatic uterine placentomata. *Endocrinology*, **28**, 933-945.
- EVANS, H. M., SIMPSON, M. E., TOLKSDORF, S., AND JENSEN, H. 1939. Biological studies of the gonadotropic principles in sheep pituitary substance. *Endocrinology*, **25**, 529-546.
- EVANS, L. T. 1948. The effects of gonadotropic and androgenic hormones upon dorso-nuchal crest of the lizard. *Anat. Rec.*, **100**, 657-658.
- EVERETT, J. W. 1940. Restoration of ovulatory cycles and corpus luteum formation in persistent-estrous rats by progesterone. *Endocrinology*, **27**, 681-686.
- EVERETT, J. W. 1941. Evidence suggesting a role of the lactogenic hormone in the estrous cycle of the albino rat. *Endocrinology*, **35**, 507-520.
- EVERETT, J. W. 1948. Progesterone and estrogen in the experimental control of ovulation time and other features of the estrous cycle in the rat. *Endocrinology*, **43**, 389-405.
- EVERETT, J. W. 1950. Pituitary-ovarian relationships. In *Progress in Clinical Endocrinology*, S. Soskin, Ed., p. 319. New York: Grune & Stratton, Inc.
- EVERETT, J. W. 1954. Lutetrophic function of autografts of the rat hypophysis. *Endocrinology*, **54**: 685-690.
- EVERETT, J. W. 1956. Functional corpora lutea maintained for months by autografts of rat hypophyses. *Endocrinology*, **58**, 786-796.
- EVERETT, J. W., AND SAWYER, C. H. 1949. A neural timing factor in the mechanism by which progesterone advances ovulation in the cyclic rat. *Endocrinology*, **45**, 581-595.
- EVERETT, J. W., SAWYER, C. H., AND MARKEE, J. E. 1949. A neurogenic timing factor in control of the ovulatory discharge of luteinizing hormone in the cyclic rat. *Endocrinology*, **44**, 234-250.
- EWELL, J. W., MUNSON, P. L., AND SALTER, W. T. 1950. Endocrinopathy during education for professional careers: effects of therapy. *A. Res. Nerv. & Ment. Dis., Proc.*, **29**, 458-468.
- FARNER, D. S., MEWALDT, L. R., AND IRVING, S. D. 1953. The roles of darkness and light in the activation of avian gonads. *Science*, **118**, 351.
- FERRER, J. 1957. Correlation of the vascular supply of the pars distalis of the rat's adenohypophysis with the distribution of the basophilic cells. *Anat. Rec.*, **127**, 527-537.
- FERRER, J., AND DANNI, P. T. 1954. Zonal "Basophilic Pituitogram" of the anterior pituitary gland of the normal male rat. *Acta physiol. latinoam.*, **4**, 141-146.
- FEVOLD, H. L. 1939. Functional synergism of the follicle stimulating and luteinizing hormones of the pituitary. *Anat. Rec., Suppl.* **2**, **73**, 19.
- FEVOLD, H. L. 1943. The luteinizing hormone of the anterior lobe of the pituitary body. *Ann. New York Acad. Sc.*, **43**, 321-339.
- FIGGE, F. H. J., AND ALLEN, E. 1942. Genital atrophy during pantothenic acid deficiency and responses to gonadotropic and estrogenic hormones. *Endocrinology*, **30**, 1028.
- FINERTY, J. C. 1952. Parabiosis in physiological studies. *Physiol. Rev.*, **32**, 277-302.
- FLUHMAN, C. F., AND LAQUEUR, G. L. 1943. Action of testosterone and prolactin on the corpora lutea of the rat. *Proc. Soc. Exper. Biol. & Med.*, **54**, 223-225.
- FORBES, T. R. 1937. Studies on the reproductive system of the alligator. I. The effects of prolonged injections of pituitary whole gland extract in the immature alligator. *Anat. Rec.*, **70**, 113-137.
- FOSTER, M. A., FOSTER, R. C., AND HISAW, F. J. 1937. The interrelationship of the pituitary

- sex hormones in ovulation, corpus luteum formation, and corpus luteum secretion in the hypophysectomized rabbit. *Endocrinology*, **21**, 249-259.
- FRAENKEL-CONRAT, H., LI, C. H., SIMPSON, M. E., AND EVANS, H. M. 1940. Interstitial cell stimulating hormone: biological properties. *Endocrinology*, **27**, 793-802.
- FRAENKEL-CONRAT, H., SIMPSON, M. E., AND EVANS, H. M. 1940. Interstitial cell stimulating hormone. III. Methods of estimating the hormonal content of pituitaries. *Endocrinology*, **27**, 809-817.
- FRAPS, R. M., AND DURY, A. 1943. Relative effectiveness of various gonadotropins in the induction of ovulation in the hen. *Anat. Rec.*, **87**, 442-443.
- FRAPS, R. M., FEYOLD, H. L., AND NEHER, B. H. 1947. Ovulatory response of the hen to presumptive luteinizing and other fractions from fowl anterior pituitary tissue. *Anat. Rec.*, **99**, 571-572.
- FRAPS, R. M., HOOKER, C. W., AND FORBES, T. R. 1948. Progesterone in blood plasma of ovulating hen. *Science*, **108**, 86.
- FRAPS, R. M., HOOKER, C. W., AND FORBES, T. R. 1949. Progesterone in blood plasma of cocks and nonovulating hens. *Science*, **109**, 493.
- FRIED, P. H., AND RAKOFF, A. E. 1952. The effects of chorionic gonadotropin and of prolactin on the maintenance of corpus luteum function. *J. Clin. Endocrinol.*, **12**, 321-337.
- FRIEDGOOD, H. B., AND CANNON, W. B. 1940. Autonomic control of thyroid secretion. *Endocrinology*, **26**, 142-152.
- FRIEDGOOD, H. B., AND PISCUS, G. 1935. Studies on conditions of activity in endocrine organs. XXX. The nervous control of the anterior hypophysis as indicated by maturation of ova and ovulation after stimulation of cervical sympathetics. *Endocrinology*, **19**, 710-717.
- FRIEDMAN, M. H. AND FRIEDMAN, G. S. 1940. Relation of diet to restitution of gonadotropic hormone content of discharged rabbit pituitary. *Am. J. Physiol.*, **128**, 493-499.
- FUXNELL, J. W., KEATY, C., AND HELLBAUM, A. A. 1951. Action of oestrogens on release of luteinizing hormone in menopausal women. *J. Clin. Endocrinol.*, **11**, 98-102.
- GAARENSTROOM, J. H., AND DE JONGH, S. E. 1946. *Contribution to the Knowledge of the Influences of Gonadotrophic and Sex Hormones on the Gonads of Rats*. Amsterdam: Elsevier Publishing Company.
- GAARENSTROOM, J. H., AND DE JONGH, S. E. 1948. Gonadotropic potency of the hypophysis in oestrogen-treated rats. *Acta endocrinol.*, **1**, 97-101.
- GALLEN, L. 1955. Discussion of C. L. Smith's Reproduction in female amphibia. In *Comparative Physiology of Reproduction, Memoirs of the Society for Endocrinology*, No. 4, E. Chester Jones and P. Eckstein, Eds., p. 56. London: Cambridge University Press.
- GALLI MAININI, C. 1948. Pregnancy test using the male Batrachia. *J. A. M. A.*, **138**, 121-125.
- GAXONG, W. F., FREDRICKSON, D. S., AND HUME, D. M. 1955. The effect of hypothalamic lesions on thyroid function in dog. *Endocrinology*, **57**, 355-362.
- GAUPE, V., AND SPATZ, H. 1955. Hypophysenstieldurchtrennung und Gerlechtsstreifung, über regeneration-schneidungen an der suprasellaren hypophyse. *Acta neuroveg.*, **12**, 285-328.
- GILLMAN, J., AND GILLMAN, T. 1951. *Perspectives in Human Malnutrition*. New York: Grune and Stratton, Inc.
- GODFREY, E. F., AND JAAP, R. G. 1950. Estrogenic interruption of broodiness in the domestic fowl. *Poultry Sc.*, **29**, 356-361.
- GORBMAN, A. 1941. Comparative anatomy and physiology of the anterior pituitary. *Quart. Rev. Biol.*, **16**, 291-310.
- GRAYHACK, J. T., BUNCE, P. L., KEARNS, J. W., AND SCOTT, W. W. 1955. Influence of pituitary on prostatic response to androgen in the rat. *Bull. Johns Hopkins Hosp.*, **96**, 154-163.
- GREELEY, F., AND MEYER, R. K. 1953. Seasonal variation in testis-stimulating activity of male pheasant pituitary glands. *Auk*, **70**, 350-358.
- GREEN, J. D. 1947. Vessels and nerves of amphibian hypophyses: a study of the living circulation and of the histology of the hypophysial vessels and nerves. *Anat. Rec.*, **99**, 21-53.
- GREEN, J. D. 1948. The histology of the hypophysial stalk and median eminence in man with special reference to blood vessels, nerve fibers, and a peculiar neurovascular zone in this region. *Anat. Rec.*, **100**, 273-296.
- GREEN, J. D. 1951a. The comparative anatomy of the hypophysis with special reference to its blood supply and innervation. *Am. J. Anat.*, **88**, 225-312.
- GREEN, J. D. 1951b. Innervation of the pars distalis of the adenohypophysis studied by phase microscopy. *Anat. Rec.*, **109**, 99-108.
- GREEN, J. D. 1952. Comparative aspects of the hypophysis, especially of blood supply and innervation. *Ciba Foundation Colloquia Endocrinol.*, **4**, 72-86.
- GREEN, J. D., AND HARRIS, G. W. 1947. The neurovascular link between the neurohypophysis and adenohypophysis. *J. Endocrinol.*, **5**, 136-146.
- GREEN, J. D., AND HARRIS, G. W. 1949. Observation of the hypophysio-portal vessels of the living rat. *J. Physiol.*, **108**, 359-361.
- GREEN, S. H., AND ZUCKERMAN, S. 1947. A comparison of the growth of the ovum and follicle in normal rhesus monkeys and in monkeys treated with oestrogens and androgens. *J. Endocrinol.*, **5**, 207-219.
- GREER, R. O. 1938. The effect of gonadotropic hormones on the persisting corpora lutea in hypophysectomized rats. *Endocrinology*, **23**, 154-163.
- GREER, R. O. 1939. Some effects of androgens and gonadotropic preparations on the repro-

- ductive system of hypophysectomized adult male rats and rabbits. *Anat. Rec.*, **73**, 23.
- GREEP, R. O., AND BARNETT, R. J. 1951. Effect of pituitary stalk-section on reproductive organs of female rats. *Endocrinology*, **49**, 172-184.
- GREEP, R. O., AND CHESTER JONES, I. 1950a. Steroids and pituitary hormones. In *Symposium. Steroid Hormones*, E. S. Gordon, Ed. Madison: University of Wisconsin Press.
- GREEP, R. O., AND CHESTER JONES, I. 1950b. Steroid control of pituitary function. *Recent Progr. Hormone Res.*, **5**, 197-261.
- GREEP, R. O., AND FEVOLD, H. L. 1937. The spermatogenic and secretory function of the gonads of hypophysectomized adult rats treated with pituitary FSH and LH. *Endocrinology*, **21**, 611-618.
- GREEP, R. O., FEVOLD, H. L., AND HISAW, F. L. 1936. Effects of two hypophyseal gonadotropic hormones on the reproductive system of the male rat. *Anat. Rec.*, **65**, 261-271.
- GREEP, R. O., VAN DYKE, H. B., AND CHOW, B. F. 1940. The effect of pituitary gonadotropins on the testicles of hypophysectomized immature rats. *Anat. Rec.*, **78**, 88.
- GREEP, R. O., VAN DYKE, H. B., AND CHOW, B. F. 1941. Use of anterior lobe of prostate gland in assay of metakentrin. *Proc. Soc. Exper. Biol. & Med.*, **46**, 644-649.
- GREEP, R. O., VAN DYKE, H. B., AND CHOW, B. F. 1942. Gonadotropins of the swine pituitary. I. Various biological effects of purified thyloketin (FSH) and pure metakentrin (ICSH). *Endocrinology*, **30**, 635-649.
- GREER, M. A. 1953. The effect of progesterone on persistent vaginal estus produced by hypothalamic lesions in the rat. *Endocrinology*, **53**, 380-390.
- GRIESER, K. C., AND BROWMAN, L. G. 1956. Total gonadotropic potency of mule deer pituitaries. *Endocrinology*, **58**, 206-211.
- GUILLEMIN, R., HEARN, W. R., CHEEK, W. R., AND HOUSSHOLDER, D. E. 1957. Control of corticotrophin release: further studies with *in vitro* methods. *Endocrinology*, **60**, 488-506.
- HAGEX, E. 1951. Neurohistologische Befunde an Hypophyse und Zwischenhirn des Menschen. *Acta neuroveg.*, **3**, 67-74.
- HALMI, N. S. 1950. Two types of basophils in the anterior pituitary of the rat and their respective cytophysiological significance. *Endocrinology*, **47**, 289-299.
- HALMI, N. S. 1952. Two types of basophils in the rat pituitary: "thyrotrophs" and "gonadotrophs" vs. beta and delta cells. *Endocrinology*, **50**, 140-142.
- HAMMOND, J., JR. 1945. Induced ovulation and heat in anoestrous sheep. *J. Endocrinol.*, **4**, 167-180.
- HAMMOND, J., JR. 1949. Induced twin ovulations and multiple pregnancy in cattle. *J. Agric. Sci.*, **39**, 222-225.
- HAMMOND, J., JR. 1953. Photoperiodicity in animals: the role of darkness. *Science*, **117**, 389-391.
- HAMMOND, J., JR., HAMMOND, J., AND PARKES, A. S. 1942. Hormonal augmentation of fertility in sheep. I. Induction of ovulation, superovulation, and heat in sheep. *J. Agric. Sci.*, **32**, 308-323.
- HANSEL, W., AND TRIMBERGER, G. W. 1952. The effect of progesterone on ovulation time in dairy heifers. *J. Dairy Sci.*, **35**, 65-70.
- HARRIS, G. W. 1936. The induction of pseudopregnancy in the rat by electrical stimulation through the head. *J. Physiol.*, **88**, 361-367.
- HARRIS, G. W. 1937. The induction of ovulation in the rabbit by electrical stimulation of the hypothalamo-hypophysial mechanism. *Proc. Roy. Soc. London, ser. B*, **122**, 374-394.
- HARRIS, G. W. 1947a. The innervation and actions of the neurohypophysis: an investigation using method of remote control. *Philos. Tr. Roy. Soc.*, **232**, 385-441.
- HARRIS, G. W. 1947b. Blood vessels of the rabbit's pituitary gland, and significance of pars and zona tuberalis. *J. Anat.*, **81**, 343-351.
- HARRIS, G. W. 1948a. Neural control of pituitary gland. *Physiol. Rev.*, **28**, 139-179.
- HARRIS, G. W. 1948b. Electrical stimulation of hypothalamus and mechanism of neural control of adenohypophysis. *J. Physiol.*, **107**, 418-429.
- HARRIS, G. W. 1949. Regeneration of hypophysial portal vessels. *Nature, London*, **163**, 70.
- HARRIS, G. W. 1950. Oestrous rhythm. Pseudopregnancy and the pituitary stalk in the rat. *J. Physiol.*, **111**, 347-360.
- HARRIS, G. W. 1955. *Neural Control of the Pituitary Gland*. Baltimore: The Williams & Wilkins Company.
- HARRIS, G. W., AND JACOBSON, D. 1952. Functional hypophysial grafts. *Ciba Foundation Colloquia Endocrinol.*, **4**, 115-119.
- HARRIS, G. W., AND JOHNSON, R. T. 1950. Regeneration of hypophysial portal vessels, after section of the hypophysial stalk, in the monkey (*Macacus rhesus*). *Nature, London*, **165**, 819-820.
- HARTMAN, A. M., DRYDEN, L. P., AND CARY, C. A. 1949. Role and sources of vitamin B<sub>12</sub> in the normal mammal. U.S. Dept. Agric., BDM-1NF-76 (July 1949).
- HASKINS, A. L., AND SHERMAN, A. I. 1952. Quantitative assay of serum chorionic gonadotropin in pregnancy, using modified male frog technique. *J. Clin. Endocrinol.*, **12**, 385-392.
- HASLER, A. D., MEYER, R. K., AND FIELD, H. M. 1939. Spawning induced prematurely in trout with the aid of pituitary glands of the carp. *Endocrinology*, **25**, 978-983.
- HATERIUS, H. O. 1934. Genital pituitary pathway. Noeffect of stimulation of superior cervical sympathetic ganglia. *Proc. Soc. Exper. Biol. & Med.*, **31**, 1112-1113.
- HATERIUS, H. O., AND DERRYS-HIRE, A. J., JR. 1937. Ovulation in the rabbit following upon stimulation of the hypothalamus. *Am. J. Physiol.*, **119**, 329-330.
- HAYS, E. E., AND STEELMAN, S. L. 1955. Chemistry of the anterior pituitary hormones. In *7th*

- Hocmoms*, Vol. III, G. Pincus and K. V. Thimann, Eds. New York: Academic Press, Inc.
- HECKEL, N. J. 1940. The influence of testosterone propionate upon benign prostatic hypertrophy and spermatogenesis: a clinical and pathological study in the human. *J. Urol.*, **43**, 286-308.
- HECKEL, N. J., AND McDONALD, J. H. 1952. The effects of testosterone propionate upon the spermatogenic function of the human testis. *Ann. New York Acad. Sc.*, **55**, 725-733.
- HECKEL, N. J., ROSSO, W. A., AND KESTEL, L. 1951. Spermatogenic rebound phenomenon after administration of testosterone propionate. *J. Clin. Endocrinol.*, **11**, 235-245.
- HELLBRUNN, L. V., DOUGHERTY, K., AND WILBUR, K. M. 1939. Initiation of maturation in the frog egg. *Physiol. Zool.*, **12**, 97-100.
- HELLBAUM, A. A. 1935. The gonad-stimulating activity of pituitary glands from horses of different ages and sex types. *Anat. Rec.*, **63**, 147.
- HELLBAUM, A. A., AND GREEP, R. O. 1938. Gonad-stimulating abilities of male and female rat pituitary glands. *Proc. Soc. Exper. Biol. & Med.*, **38**, 902-904.
- HELLBAUM, A. A., AND GREEP, R. O. 1940. Qualitative changes in the gonadotropic complex of the rat pituitary following removal of the testes. *Am. J. Anat.*, **67**, 287-304.
- HELLBAUM, A. A., AND GREEP, R. O. 1943. Qualitative changes induced in gonadotropic complex of pituitary by testosterone propionate. *Endocrinology*, **32**, 33-40.
- HELLER, C. G., CHANDLER, R. E., AND MYERS, G. B. 1944. Effect of small and large doses of diethylstilbestrol upon menopausal symptoms, vaginal smear and urinary gonadotrophins in 23 oophorectomized women. *J. Clin. Endocrinol.*, **4**, 109-116.
- HELLER, C. G., AND HELLER, E. J. 1939. Gonadotrophic hormone: urine assay of normal cycling, menopausal, castrated, and estrin treated human females. *J. Clin. Invest.*, **18**, 171-178.
- HELLER, C. G., HELLER, E. J., AND SEYRINGHAUS, E. L. 1942. Does estrogen substitution materially inhibit pituitary gonadotrophic potency? *Endocrinology*, **30**, 309-316.
- HELLER, C. G., NELSON, W. O., HILL, I. C., HENDERSON, E., MADDOCK, W. O., JUNGCK, E. C., PAULSEN, C. A., AND MORTIMORE, G. E. 1950. Improvement in spermatogenesis following depression of human testis with testosterone. *Fertil. & Steril.*, **1**, 415-422.
- HELLER, C. G., NELSON, W. O., MADDOCK, W. O., JUNGCK, E. C., PAULSEN, C. A., AND MORTIMORE, G. E. 1951. Effects of testosterone on human testis. *J. Clin. Invest.*, **30**, 648.
- HELLER, C. G., SEGALOFF, A., AND NELSON, W. O. 1943. Effect of testosterone propionate on pituitary gonadotrophic potency of castrated male rat. *Endocrinology*, **33**, 186-188.
- HENDERSON, W. R., AND ROWLANDS, I. W. 1938. Gonadotrophic activity of anterior pituitary gland in relation to increased intracranial pressure. *Brit. M. J.*, **1**, 1091-1097.
- HERTZ, R., AND HISAW, F. L. 1934. Effect of follicle-stimulating and luteinizing pituitary extracts on ovaries of infantile and juvenile rabbit. *Am. J. Physiol.*, **108**, 1-13.
- HERTZ, R., AND MEYER, R. K. 1937. Effect of testosterone, testosterone propionate, and dehydroandrosterone on secretion of gonadotrophic complex as evidenced in parabiotic rats. *Endocrinology*, **21**, 756-762.
- HILLARP, N. A. 1949. Studies on the localization of hypothalamic centers controlling the gonadotrophic function of the hypophysectomized rat. *Acta endocrinol.*, **2**, 11-23.
- HISAW, F. L. 1944. The placental gonadotrophin and luteal function in monkeys (*Macaca mulatta*). *Yale J. Biol. & Med.*, **17**, 119-137.
- HISAW, F. L. 1947. Development of the Graafian follicle and ovulation. *Physiol. Rev.*, **27**, 95-119.
- HISAW, F. L., AND ALBERT, A. Quoted by Dodd, J. M., *vide supra*.
- HISAW, F. L., AND ASTWOOD, E. B. 1942. The physiology of reproduction. *Annual Rev. Physiol.*, **4**, 503-560.
- HOAR, W. S. 1955. Reproduction in teleost fish. In *Comparative Physiology of Reproduction, Memoirs of the Society for Endocrinology*, No. 4, Chester Jones and Eckstein, Eds. London: Cambridge University Press.
- HOBSON, B. M. 1952. Routine pregnancy diagnosis and quantitative estimation of chorionic gonadotrophin using female *Xenopus laevis*. *J. Obst. & Gynaec. Brit. Emp.*, **59**, 352-362.
- HOHLWEG, W. 1934. Veränderungen des hypophysenvorderlappens und des ovariums nach Behandlung mit grossen dosen von Follikelhormon. *Klin. Wochenschr.*, **13**, 92-95.
- HÖKFELT, B., LÜFT, R., IKKOS, D., OLIVECRONA, H., AND SEKENES, J. 1959. The immediate effect of hypophysectomy and section of the pituitary stalk on the urinary steroid excretion in man. *Acta endocrinol.*, **30**, 29-36.
- HOLLANDBECK, R., BAKER, B., JR., NORTON, H. W., AND NALBANDOV, A. V. 1956. Gonadotrophic hormone content of swine pituitary glands in relation to age. *J. Anim. Sc.*, **15**, 418-427.
- HOLMSTROM, E. G., AND JONES, W. J. 1949. Experimental production of menorrhagia by administration of gonadotropins. *Am. J. Obst. & Gynec.*, **58**, 308-317.
- HOOGSTRA, M. J., AND PAESI, F. J. A. 1955. A comparison between the FSH- and ICSH-contents of the hypophysis of adult and immature rats. *Acta physiol. et pharmacol. neerl.*, **4**, 395-405.
- HOOGSTRA, M. J., AND PAESI, F. J. A. 1957. The FSH content of the hypophysis of the rat as influenced by androgen. *Acta endocrinol.*, **24**, 353-360.
- HOUSSAY, B. A. 1951. Hormonal regulation of the sexual function of the male toad. *Acta physiol. latinoam.*, **4**, 2-41.
- HOUSSAY, B. A., AND GUSTI, L. 1930. Función sexual hipófisis e hipotálamo en el sapo. *Rev. Soc. argent. biol.*, **6**, 146.
- HOWARD, E. 1939. Effects of castration on the



- seminal vesicles as influenced by age considered in relation to the degree of development of the adrenal X zone. *Am. J. Anat.*, **65**, 105-135.
- IHRING, R. VON 1937. A method for inducing fish to spawn. *Progr. Fish Culturist*, **3**, 15-16.
- JENNER, C. E., AND ENGELS, W. L. 1952. The significance of the dark period in the photo-periodic response of male juncos and white-throated sparrows. *Biol. Bull. Woods Hole*, **103**, 345-355.
- JOST, A. 1951. Recherches sur la différenciation sexuelle de l'embryon de lapin. IV. Organogénèse sexuelle masculine après décapitation du foetus. *Arch. Anat. microscop. et Morphol. expériment.*, **40**, 247.
- JOST, A. 1953. Problems of fetal endocrinology: The gonadal and hypophysial hormones. *Recent Progr. Hormone Res.*, **8**, 379-418.
- JOST, A. 1955. Modalities in the action of gonadal and gonad-stimulating hormones in the foetus. In *Comparative Physiology of Reproduction, Memoirs of the Society for Endocrinology*, No. 4. I. Chester Jones and P. Eckstein, Eds. London: Cambridge University Press.
- JOST, A. 1956a. The secretory activities of fetal endocrine glands and their effect upon target organs. *Macy Foundation Conferences on Gestation*, **3**, 129-171.
- JOST, A. 1956b. L'analyse expérimentale de l'endocrinologie foetale. *Problème des Fœtales Endokrinologie*, p. 14. Dozent Dr. H. Nowakowski. Berlin: Springer-Verlag.
- KAMMLADE, W. G., JR., WELSH, J. A., NALBANDOV, A. V., AND NORTON, H. W. 1952. Pituitary activity of sheep in relation to breeding season. *J. Anim. Sc.*, **11**, 646-655.
- KARPLUS, J., AND KRIEDEL, A. 1910. Operationen am überhangenden Gehirn. *Wien. klin. Wchnschr.*, **23**, 309-310.
- KAZANSKI, B. M. 1940. Zur Frage der systematischen Spezifität des gonadotropen Hormons der Hypophyse bei den fischen. *Compt. rend. Acad. Sc. URSS*, **27**, 180-184.
- KEHL, R. 1944. Études de quelques problèmes d'endocrinologie génitale chez un certains reptiles du sud-algerien. *Rev. canad. biol.*, **3**, 131-219.
- KEHL, R., AUDIBERT, A., GAGE, C., AND AMARGER, J. 1956. Influence expérimentale de la réserpine sur l'activité hypophysogénitale. *Compt. rend Soc. biol.*, **150**, 981-983.
- KEHL, R., AND COMBESCOT, C. 1955. Reproduction in the reptilia. In *Comparative Physiology of Reproduction, Memoirs of the Society for Endocrinology*, No. 4. I. Chester Jones and P. Eckstein, Eds. London: Cambridge University Press.
- KELLER, A. D., AND HAMILTON, J. W., JR. 1937. Normal sex functions following section of the hypophysal stalk in the dog. *Am. J. Physiol.*, **119**, 349-350.
- KEMPF, R. 1949. Effet de l'administration de progesterone sur la structure de greffes ovariennes chez le rat male chatte. *Comp. rend. Soc. biol.*, **143**, 1006-1008.
- KEMPF, R. 1950. Contribution a l'etude du mecanisme de liberation des hormones gonadotropes hypophysaires chez le rat. *Arch. biol.*, **61**, 501-592.
- KEYS, A. 1946. Human starvation and its consequences. *J. Am. Dietet. A.*, **22**, 582-587.
- KEYS, A., BROZEC, J., HENSCHEL, A., MICHELSON, D., AND TAYLOR, H. L. 1950. *The Biology of Human Starvation*. Minneapolis: University of Minnesota Press.
- KIRKPATRICK, C. M., AND LEOPOLD, A. C. 1952. The role of darkness in sexual activity of the quail. *Science*, **116**, 280-281.
- KISSEK, A. T. 1954. Effect of gonadotropic hormones on hypophysectomy (anterior lobe) male *Rana pipiens*. *Ohio J. Sc.*, **54**, 187-191.
- KLEINHOLZ, L. H., AND RAHN, H. 1939. Distribution of intermedin in pars anterior of chicken pituitary. *Proc. Nat. Acad. Sc.*, **25**, 145-147.
- KLINEFELTER, H. F., JR., ALBRIGHT, F., AND GRISWOLD, G. C. 1943. Experience with quantitative test for normal or decreased amounts of follicle stimulating hormone in urine in endocrinological diagnosis. *J. Clin. Endocrinol.*, **3**, 529-544.
- KNIGGE, K. M., AND LEATHEM, J. H. 1956. Growth and atresia of follicles in the ovary of the hamster. *Anat. Rec.*, **124**, 679-698.
- KNOBIL, E., AND BIGGS, F. N. 1955. Fetal-maternal endocrine interrelations: hypophysial-adrenal system. *Endocrinology*, **57**, 147-152.
- KNOBIL, E., AND GREEP, R. O. 1956. The physiological action of growth hormone in primates: A problem of species specificity. In *Proceedings XX International Physiological Congress*, Brussels.
- KNOBIL, E., KOSTYO, J. L., AND GREEP, R. O. 1959. Production of ovulation in the hypophysectomized rhesus monkey. *Endocrinology*, **65**, 487-493.
- KOENIG, V., AND KING, E. 1950. Extraction studies of sleep pituitary gonadotropic and laetogenic hormones in alcoholic acetate buffers. *Arch. Biochem.*, **26**, 219-229.
- KORNFIELD, W., AND NALBANDOV, A. V. 1954. Endocrine influences on the development of the rudimentary gonad of fowl. *Endocrinology*, **55**, 751-761.
- KUPPERMAN, H. S., ELDER, W. H., AND MEYER, R. K. 1941. Effect of method of desiccation and storage on gonadotropic activity of pituitary gland. *Endocrinology*, **29**, 23-26.
- LADMAN, A. J., AND RUNNER, M. N. 1951. Comparison of sensitivities of immature and pregnant mouse for estimation of gonadotropin. *Endocrinology*, **48**, 358-364.
- LADMAN, A. J., AND RUNNER, M. N. 1953. Demonstration of storage and release of gonadotropin by anterior pituitary of mouse during gestation. *Endocrinology*, **53**, 367-379.
- LAQUEUR, G. L., McCANN, S. M., SCHREINER, L. H., ROSENBERG, E., RHOCH, D. McK., AND ANDERSON, E. 1955. Alterations of adrenal cortical

- and ovarian activity following hypothalamic lesions based on eosinophile response, hormone assay and histological examination. *Endocrinology*, **57**, 44-54.
- LASCANO-GONZÁLEZ, J. M. 1935. Infarctus hipofisarios después lesión infundibulotuberérica en el crapaud. *Compt. rend. Soc. Biol.*, **120**, 723-724.
- LAUSON, H., HELLER, C. G., AND SEVRINGHAUS, E. L. 1938. Inadequacies of estradiol substitution in ovariectomized albino rats. *Endocrinology*, **23**, 479-484.
- LEATHLEM, J. H. 1944. Influence of testosterone propionate on adrenals and testes of hypophysectomized rats. *Anat. Rec.*, **89**, 155-161.
- LEATHLEM, J. H. 1958. Hormones and protein nutrition. *Recent Progr. Hormone Res.*, **14**, 141-182.
- LEBLOND, C. P., AND NOBLE, G. K. 1937. Prolactin-like reaction produced by hypophyses of various vertebrates. *Proc. Soc. Exper. Biol. & Med.*, **36**, 517-518.
- LEININGER, C. R., AND RANSON, S. W. 1943. Effect of hypophysial stalk transection upon gonadotrophic function in guinea pig. *Anat. Rec.*, **87**, 77-83.
- LEONORA, J., MCSHANE, W. H., AND MEYER, R. K. 1956. Factors affecting extraction and recovery of follicle-stimulating hormone from sheep pituitary glands. *Proc. Soc. Exper. Biol. & Med.*, **92**, 524-529.
- LEONARD, S. L. 1937. Luteinizing hormone in bird hypophysis. *Proc. Soc. Exper. Biol. & Med.*, **37**, 566-568.
- LI, C. H. 1949. The chemistry of gonadotropic hormones. *Vitamins & Hormones*, **7**, 223-252.
- LI, C. H. 1957. Hormones of the anterior pituitary gland. II. Melanocyte-stimulating and lactogenic hormones. In *Advances in Protein Chemistry*, Vol. 7, p. 269. New York: Academic Press.
- LI, C. H., AND EVANS, H. M. 1948. Chemistry of anterior pituitary hormones. In *The Hormones*, G. Pincus and K. V. Thimann, Eds., Vol. 1, p. 631. New York: Academic Press, Inc.
- LI, C. H., AND PEDERSON, K. O. 1952. Physicochemical characterization of pituitary follicle-stimulating hormone. *J. Gen. Physiol.*, **35**, 629-637.
- LI, C. H., SIMPSON, M. E., AND EVANS, H. M. 1940a. Purification of pituitary interstitial cell-stimulating hormone. *Science*, **92**, 355-356.
- LI, C. H., SIMPSON, M. E., AND EVANS, H. M. 1940b. Interstitial cell-stimulating hormone. II. Method of preparation and some physicochemical studies. *Endocrinology*, **27**, 803-817.
- LI, C. H., SIMPSON, M. E., AND EVANS, H. M. 1949. Isolation of pituitary follicle-stimulating hormone (FSH). *Science*, **109**, 445-446.
- LIPSCHÜTZ, A., IGLESIAS, R., BRUZZONE, S., HUMEREZ, J., AND PÉÑARANDA, J. M. 1948. Progesterone and desoxy corticosterone in steroid control of gonadotropic function of hypophysis. *Endocrinology*, **42**, 201-209.
- LLOYD, C. W., AND WILLIAMS, R. H. 1948. Endocrine changes associated with Laennee's cirrhosis of liver. *Am. J. Med.*, **4**, 315-330.
- LORAINÉ, J. A., AND DRZŻALCZY, E. 1958. The effect of prolactin on urinary gonadotropin assays. *J. Endocrinol.*, **17**, 425-432.
- LOSTROI, A. J., AND LI, C. H. 1956. La acción de la hormona de crecimiento y de la hormona lactogénica hipofisarias sobre los órganos sexuales accesorios de rats machos castrados e hipofisopivas. *Rev. Argent. Endocrinol. Metab.*, **2**, 213.
- LOSTROI, A. J., SQUIRE, P. G., AND LI, C. H. 1958. Bioassay of interstitial cell-stimulating hormone in the hypophysectomized male rat by the ventral prostate test. *Endocrinology*, **62**, 833-842.
- LUDWIG, D. J. 1950. The effect of androgen on spermatogenesis. *Endocrinology*, **46**, 453-481.
- LYONS, R. 1942. Lactogenic hormone prolongs the time during which deciduomata may be induced in lactating rats. *Proc. Soc. Exper. Biol. & Med.*, **51**, 156-157.
- LYONS, W. R. 1937. Preparation and assay of mammotropic hormone. *Proc. Soc. Exper. Biol. & Med.*, **35**, 645-648.
- LYONS, W. R., LI, C. H., JOHNSON, R. E., AND COLE, R. D. 1953. Evidence for progesterone secretion by ACTH-stimulated adrenals. *Proc. Soc. Exper. Biol. & Med.*, **84**, 356-358.
- LYONS, W. R., AND PAGE, E. 1935. Detection of mammotropin in urine of lactating women. *Proc. Soc. Exper. Biol. & Med.*, **32**, 1049-1050.
- MADDOCK, W. O. 1954. Quoted by STEELMAN, S. L., LAMONT, W. A. AND BALTES, B. J. *Endocrinology*, **56**, 216-217.
- MADDOCK, W. O., AND HELLER, C. G. 1947. Dichotomy between hypophysial content and amount of circulating gonadotrophins during starvation. *Proc. Soc. Exper. Biol. & Med.*, **66**, 595-598.
- MAHONEY, W., AND SHEEHAN, D. 1936. Pituitary-hypothalamic mechanism: experimental occlusion of pituitary stalk. *Brain*, **59**, 61-75.
- MANDL, A., AND ZUCKERMAN, S. 1950. Numbers of normal and atretic oocytes in unilaterally spayed rats. *J. Endocrinol.*, **7**, 112-119.
- MANDL, A. M., AND ZUCKERMAN, S. 1951. Time of vaginal opening in rats after ovarian autotransplantation. *J. Endocrinol.*, **7**, 335-338.
- MANDL, A. M., AND ZUCKERMAN, S. 1952. Growth of oocyte and follicle in adult rat. *J. Endocrinol.*, **8**, 126-132.
- MARBEN, W. G. R. 1952. The hormone control of ovulation in the calf. *Endocrinology*, **50**, 456-461.
- MARKEE, J. E., EVERETT, J. W., AND SAWYER, C. H. 1952. Sex cycles: the relationship of the nervous system to the release of gonadotrophin and the regulation of the sex cycle. *Recent Progr. Hormone Res.*, **7**, 139-157.
- MARKEE, J. E., SAWYER, C. H., AND HOLLINSHEAD, W. H. 1946. Activation of anterior hypophysis by electrical stimulation in rabbit. *Endocrinology*, **38**, 345-357.
- MARSHALL, A. J. 1955. Reproduction in birds:

- the male. In *Comparative Physiology of Reproduction. Memoirs of the Society for Endocrinology*, No. 4. I. Chester Jones and P. Eckstein, Eds. London: Cambridge University Press.
- MARSHALL, F. H. A. 1942. Extroreceptive factors in sexual periodicity. *Biol. Rev.*, **17**, 68-90.
- MARSHALL, F. H. A., and VERNEY, E. B. 1936. The occurrence of ovulation and pseudo-pregnancy in the rabbit as a result of central nervous stimulation. *J. Physiol.*, **86**, 327-336.
- MARVIN, H. 1948. The interruption of persistent estrus and restoration of cyclic vaginal changes in rats by injection of testosterone propionate. *Anat. Rec.*, **100**, 694-695.
- MASON, K. E. 1933. Differences in testis injury and repair after vitamin A-deficiency, vitamin E-deficiency, and inanition. *Am. J. Anat.*, **52**, 153-239.
- MATTHEWS, L. H. 1939. Visual stimulation and ovulation in pigeons. *Proc. Roy. Soc., London ser. B.*, **126**, 557-560.
- MAY, R. M., and STUTINSKY, F. 1947. Modifications histologiques des greffes bréophoplastiques intraoculaires d'hypophyses chez la souris normale. *Arch. Anat. microscop. et Morphol. exp.*, **36**, 201-212.
- MAYER, G., and CANVENC, R. 1951. Action luteotrophique et lactogène de la prolactine chez la rate. (Luteotropic and lactogenic effect of prolactine in the rat.) *Compt. rend. Soc. biol.*, **145**, 100-102.
- MAYO, V. 1937. Some effects of mammalian follicle-stimulating and luteinizing hormones in adult *Urodeles*. *Biol. Bull.*, **73**, 373-374.
- MCCARTHER, J. W., PENNELL, R. B., ANTONIADES, H. N., INGERSOLL, F. M., ONCLEY, J. L., and UELFELDER, H. 1956. Distribution and partial purification of pituitary gonadotropins of human plasma. *Proc. Soc. Exper. Biol. & Med.*, **93**, 405-407.
- MCCARTHER, J. W., INGERSOLL, F. W., and WORCESTER, J. 1958. Urinary excretion of interstitial-cell stimulating hormone by normal males and females of various ages. *J. Clin. Endocrinol.*, **18**, 460-469.
- MCCANN, S. M. 1953. Effect of hypothalamic lesions on the adrenal cortical response to stress in the rat. *Am. J. Physiol.*, **175**, 13-20.
- MCCONNELL, E. M. 1953. The arterial blood supply of the human hypophysis cerebri. *Anat. Rec.*, **115**, 175-203.
- MCCOY-QUINN, M. 1935. Sex comparison of gonadotrophic content of anterior hypophyses from rats before and after puberty. *Proc. Soc. Exper. Biol. & Med.*, **32**, 1051-1052.
- MCSHAN, W. H., and MEYER, R. K. 1938. Effect of trypsin and ptyalin preparations on gonadotrophic activity of pituitary extracts. *J. Biol. Chem.*, **126**, 361-365.
- MCSHAN, W. H., and MEYER, R. K. 1940. Preparation and properties of pituitary follicle-stimulating fractions made by trypsin digestion. *J. Biol. Chem.*, **135**, 473-482.
- MCSHAN, W. H., and MEYER, R. K. 1941. Effectiveness of heme in the augmentation of gonadotrophic extracts from different sources. *Endocrinology*, **28**, 694-700.
- MCSHAN, W. H., and MEYER, R. K. 1952. Gonadotrophic activity of granule fractions obtained from anterior pituitary glands of castrate rats. *Endocrinology*, **50**, 294-303.
- MEITES, J. 1957. Induction of lactation in rabbits with roserpine. *Proc. Soc. Exper. Biol. & Med.*, **96**, 728-730.
- MEITES, J., and REED, J. O. 1949. Effects of restricted feed intake in intact and ovariectomized rats on pituitary lactogen and gonadotrophin. *Proc. Soc. Exper. Biol. & Med.*, **70**, 513-516.
- MERCKEL, C., and NELSON, W. O. 1940. Relation of estrogenic hormone to formation and maintenance of corpora lutea in mature and immature rats. *Anat. Rec.*, **76**, 391-409.
- METZELS, J. 1954. Neurohistologische studien über die nervöse verbindung der pars distalis der hypophyse mit dem hypothalamus auf dem wege des hypophysenstieles. *Acta Anat.*, **20**, 258-285.
- MEYER, R. K., and HERTZ, R. 1937. Effect of oestrone on secretion of gonadotropic complex as evidenced by parabiotic rats. *Am. J. Physiol.*, **120**, 232-237.
- MEYER, R. K., BIDDULPH, C., and FINERTY, J. C. 1946. Pituitary-gonad interaction in immature female parabiotic rats. *Endocrinology*, **39**, 23-31.
- MIGITA, M., MATSOMOTO, J., KINOSHITA, M., SASAKI, A., and ASHIKAWA, I. 1952. Studies on the hypophysal hormone of fishes. I. Stimulating effect upon the ovulation of the trout. *Bull. Jap. Soc. sc. Fish.*, **17**, 25-31.
- MOLLER-CRISTENSEN, E., and FONSS-BECH, P. 1940. Progesterone inhibits ovulation in guinea pigs. *Endokrinologie*, **23**, 161-164.
- MOON, H. D., and LI, C. H. 1952. Effect of follicle-stimulating hormones on gonads of immature C57 black mice. *Proc. Soc. Exper. Biol. & Med.*, **79**, 505-507.
- MOORE, W. W., and NALBANDOV, A. V. 1955. Maintenance of corpora lutea in sheep with lactogenic hormone. *J. Endocrinol.*, **13**, 18-25.
- MORAWSKI, J. 1911. Die Durchtrennung des hypophysenstieles beim Affen. *Ztschr. Neurol. Psychiat.*, **7**, 207-218.
- MORTIMORE, G. E., PAULSEN, C. A., and HELLER, C. G. 1951. Effect of steroids and lactone derivatives on hypophysal gonadotrophin content. *Endocrinology*, **48**, 143-147.
- NALBANDOV, A. V. 1953a. Endocrine control of physiological functions. *Poultry Sc.*, **32**, 88-103.
- NALBANDOV, A. V. 1953b. Gonadotrophic activity of the pituitary glands and the induction of ovulation. *Iowa State College J. Sc.*, **28**, 45-54.
- NALBANDOV, A. V., and CARD, L. E. 1946. Effect of FSH and LH upon the ovaries of immature chicks and low-producing hens. *Endocrinology*, **38**, 71-78.
- NALBANDOV, A. V., and CASIDA, L. E. 1940. Gonadotrophic action of pituitaries from pregnant cows. *Endocrinology*, **27**, 559-566.

- NALBANDOV, A. V., HOCHHAUSER, M., AND DUGAS, M. 1945. A study of the effect of prolactin on bloodiness and on cock testes. *Endocrinology*, **36**, 251-258.
- NALBANDOV, A. V., MEYER, R. K., AND McSHAN, W. H. 1951. The role of a third gonadotrophic hormone in the mechanism of androgen secretion in chicken testes. *Anat. Rec.*, **110**, 475-493.
- NELSON, M. M. AND EVANS, H. M. 1951. Effect of pyridoxine deficiency on reproduction in the rat. *J. Nutrition*, **43**, 281-294.
- NELSON, W. O. 1937. Some factors involved in the control of the gametogenic and endocrine functions of the testis. Cold Spring Harbor Symposium Quant. Biol., **5**, 123-135.
- NELSON, W. O. 1952. Interrelations of gonadotrophic and gonadal hormones in the regulation of testicular functions. *Ciba Foundation Colloquia Endocrinol.*, **4**, 271-281.
- NELSON, W. O., AND MERCKEL, C. 1937a. Maintenance of spermatogenesis in testis of the hypophysectomized rat with sterol derivatives. *Proc. Soc. Exper. Biol. & Med.*, **36**, 825-828.
- NELSON, W. O., AND MERCKEL, C. 1937b. Effects of androgenic substances in female rat. *Proc. Soc. Exper. Biol. & Med.*, **36**, 823-825.
- NELSON, W. O., AND MERCKEL, C. E. 1938. Maintenance of spermatogenesis in hypophysectomized mice with androgenic substances. *Proc. Soc. Exper. Biol. & Med.*, **38**, 737-740.
- NIKITOVITCH-WINER, M., AND EVERETT, J. W. 1957. Resumption of gonadotrophic function in pituitary grafts following retransplantation from kidney to median eminence. *Nature, London*, **180**, 1434-1435.
- NIKITOVITCH-WINER, M., AND EVERETT, J. W. 1958a. Comparative study of luteotrophin secretion by hypophysial autotransplants in the rat: effects of site and stages of the estrous cycle. *Endocrinology*, **62**, 522-532.
- NIKITOVITCH-WINER, M., AND EVERETT, J. W. 1958b. Functional restitution of pituitary grafts retransplanted from kidney to median eminence. *Endocrinology*, **63**, 916-930.
- NUMURA, T. 1958. Hypophysial-ovarian relationship in persistent-estrous and persistent-anestrous rats. *J. Faculty Sc., Univ. Tokyo*, **8**, 317-335.
- NOWAKOWSKI, H. 1951. *Influndibulum und Tuberculum der Katze*. *Deutsche Ztschr. Nervenh.*, **165**, 261-339.
- NOWAKOWSKI, H. 1952. Gomori-positive and Gomori-negative nerve fibers in the neurohypophysis and their physiologic significance. *Ciba Foundation Colloquia Endocrinol.*, **4**, 65-69.
- OKLEY, R., PENCHARZ, R., AND LEPKOVSKY, S. 1950. Sex hormonal effects in incipient biotin deficiency. *Am. J. Physiol.*, **161**, 1-13.
- OLIVECRONA, H. 1957. Paraventricular nucleus and pituitary gland. *Acta Physiol., Suppl.* **136**, 40, 1-178.
- PAESI, F. J. A. 1952. The effect of small doses of estrogen on the ovary of the immature rat. *Acta endocrinol.*, **11**, 251-268.
- PAESI, F. J. A., DE JONGH, S. E., HOOGSTRA, M. J., AND ENGELBREGT, A. 1955. The follicle-stimulating hormone-content of the hypophysis of the rat as influenced by gonadectomy and estrogen treatment. *Acta endocrinol.*, **19**, 49-60.
- PAESI, F. J. A., DE JONGH, S. E., AND WILLEMSE, C. H. 1958. Testosterone and the pituitary ICSH content of male and female rats (with additional remarks on body growth). *Arch. internat. pharmacodyn.*, **116**, 217-227.
- PALAY, S. L. 1953a. Neurosecretory phenomena in the hypothalamo-hypophysial system of man and monkey. *Am. J. Anat.*, **93**, 107-141.
- PAN, S. Y., VAN DYKE, H. B., KAUNITZ, H., AND SLANETZ, C. A. 1949. Effect of vitamin-E deficiency on amount of gonadotrophin in the anterior pituitary of rats. *Proc. Soc. Exper. Biol. & Med.*, **72**, 523-526.
- PAREDIS, F. 1950. *Verhandelingen van de Koninklijke Vlaamse Acad. Geneeskunde*, **12**, 296-335.
- PARKES, A. S. 1943. Induction of superovulation and superfecundation in rabbits. *J. Endocrinol.*, **3**, 268-279.
- PARKES, A. S. 1952. *Marshall's Physiology of Reproduction*, Vol. 2, 3rd ed. London: Longmans, Green and Company.
- PARKES, A. S. 1956. *Marshall's Physiology of Reproduction*, Vol. 1, Pt. 1, 3rd ed. London: Longmans, Green and Company.
- PARLOW, A. F. 1958. A rapid bioassay method for LH and factors stimulating LH secretion. *Fed. Proc.*, **17**, 402.
- PATEL, M. D. 1936. The physiology of the formation of pigeon's milk. *Physiol. Zool.*, **9**, 129-152.
- PARLESCO, N. C. 1908. *L'Hypophyse du Cerveau*. Paris: Vigot Freres.
- PAYNE, R. W., AND HELLBUM, A. A. 1955. The effect of estrogens on the ovary of the hypophysectomized rat. *Endocrinology*, **57**, 193-199.
- PEBERSEN-BJERGAARD, K., AND TOXNESEN, M. 1948. Sex hormone analyses; excretion of sexual hormones by normal males, impotent males, polyarthritides, and prostatics. *Acta med. Scandinav.*, Suppl. 213, **131**, 284-297.
- PENCHARZ, R. I. 1940. Effect of estrogens and androgens alone and in combination with chorionic gonadotropin on ovary of hypophysectomized rat. *Science*, **91**, 554-555.
- PEIFFER, C. A. 1950. Progesterone causes ovulation of 9 monkeys during anovulatory season. *Proc. Soc. Exper. Biol. & Med.*, **75**, 455-458.
- PHILLIPS, R. E. 1943. Ovarian response of hens and pullets to injections of ambimon. *Poultry Sc.*, **22**, 368-373.
- PHILLIPS, W. A. 1937. The inhibition of estrous cycles in albino rat by progesterone. *Am. J. Physiol.*, **119**, 623-626.
- PICKFORD, G. E. 1951. The response of hypophysectomized male killifish to purified fish growth hormone, as compared with the response to purified beef hormone. *Endocrinology*, **55**, 274-287.
- PICKFORD, G. E., AND ATZ, J. W. 1957. *The Physiology of the Pituitary Gland of Fishes*. New York: New York Zoological Society.

- PINCUS, G. 1940. Superovulation in rabbits. *Anat. Rec.*, **77**, 1-8.
- POLISHUK, W. Z., AND KULCSAR, S. 1956. Effects of chlorpromazine on pituitary function. *J. Clin. Endocrinol.*, **16**, 292-293.
- PRICE, D., AND ORTIZ, E. 1944. Relation of age to reactivity in reproductive system of rat. *Endocrinology*, **34**, 215-239.
- PURVES, H. D., AND GRIESBACH, W. E. 1951a. The site of thyrotrophin and gonadotrophin production in the rat pituitary studied by the McManus-Hotchkiss staining for glycoprotein. *Endocrinology*, **49**, 244-264.
- PURVES, H. D., AND GRIESBACH, W. E. 1951b. Specific staining of the thyrotrophic cells of the rat pituitary by the Gomori stain. *Endocrinology*, **49**, 427-428.
- PURVES, H. D., AND GRIESBACH, W. E. 1955. Changes in the gonadotrophs of the rat pituitary after gonadectomy. *Endocrinology*, **56**, 374-386.
- RAHN, H., AND PAINTER, B. T. 1941. A comparative histology of the bird pituitary. *Anat. Rec.*, **79**, 297-311.
- RAMASWAMI, L. S., AND SUNDARARAJ, B. I. 1956. Induced spawning in the Indian catfish. *Science*, **123**, 1050.
- RAMASWAMI, L. S., AND SUNDARARAJ, B. I. 1957. Inducing spawning in the Indian catfish *Heteropneustes* with pituitary injections. *Acta anat.*, **31**, 551-562.
- RASQUIN, P. 1951. Effects of carp pituitary and mammalian ACTH on the endocrine and lymphoid systems of the teleost *Astyanax mexicanus*. *J. Exper. Zool.*, **117**, 317-357.
- REECE, R. P., AND TURNER, C. W. 1937. The lactogenic and thyrotrophic hormone content of the anterior lobe of the pituitary gland. *Missouri Agric. Exper. Sta. Res. Bull.*, No. 266.
- RICHES, J. H., AND WATSON, R. H. 1954. The influence of the introduction of rams on the incidence of oestrus in merino ewes. *Australian J. Agric. Res.*, **5**, 41-47.
- RIDDLE, O., BATES, R. W., AND DYKSHORN, S. W. 1932. New hormone of anterior pituitary. *Proc. Soc. Exper. Biol. & Med.*, **29**, 1211-1212.
- RIDDLE, O., BATES, R. W., AND DYKSHORN, S. W. 1933. Preparation, identification and assay of prolactin—hormone of anterior pituitary. *Am. J. Physiol.*, **105**, 191-216.
- RIDDLE, O., SMITH, G. C., BATES, R. W., MORAN, C. S., AND LAHR, E. L. 1936. Action of anterior pituitary hormones on basal metabolism of normal and hypophysectomized pigeons and on a paradoxical influence of temperature. *Endocrinology*, **20**, 1-16.
- RILEY, G. M., AND FRAPS, R. M. 1942a. Biological assays of the male chicken pituitary for gonadotrophic potency. *Endocrinology*, **30**, 529-536.
- RILEY, G. M., AND FRAPS, R. M. 1942b. Relationship of gonad-stimulating activity of female domestic fowl anterior pituitaries to reproductive activity. *Endocrinology*, **30**, 537-541.
- RINALDINI, L. M. 1949. Effect of chronic inanition on the gonadotrophic content of the pituitary gland. *J. Endocrinol.*, **6**, 54-62.
- RING, J. R. 1944. Estrogen-progesterone induction of sexual receptivity in spayed female mouse. *Endocrinology*, **34**, 269-275.
- RISLEY, P. L. 1939. Effects of gonadotropic and sex hormones on the urogenital systems of juvenile diamond-back terrapins. *Anat. Rec., Suppl.*, **75**, 104.
- ROBBINS, S. L. 1951. Observations on the use of the male North American frog (*Rana pipiens*) in pregnancy diagnosis. *J. Clin. Endocrinol.*, **11**, 213-220.
- ROBBINS, S. L., AND PARKER, F., JR. 1949. The reliability of the male North American frog (*Rana pipiens*) in the diagnosis of pregnancy. *New England J. Med.*, **241**, 12-16.
- ROBINSON, G. E., JR., AND NALBANDOV, A. V. 1951. Changes in the hormone content of swine pituitaries during the estrual cycle. *J. Anim. Sci.*, **10**, 269-278.
- ROBINSON, T. J. 1950. The control of fertility in sheep, hormonal therapy in the indication of pregnancy in the anoestrous ewe. *J. Agric. Sci.*, **40**, 275-307.
- ROBINSON, T. J. 1951. Reproduction in the ewe. *Biol. Rev.*, **26**, 121-157.
- ROBINSON, T. J. 1952. Role of progesterone in the mating behavior of the ewe. *Nature, London*, **170**, 373.
- ROBINSON, T. J. 1954. The production of coincident oestrus and ovulation in the anoestrous ewe with progesterone and pregnant mare serum. *J. Endocrinol.*, **10**, 117-123.
- ROSEN, S., SHELESNYAK, M. C., AND ZACHARIAS, L. R. 1940. Nasogenital relationship. II. Pseudopregnancy following extirpation of the sphenopakine ganglion in the rat. *Endocrinology*, **27**, 463-468.
- ROTHCHILD, I., AND FRAPS, R. M. 1949. Induction of ovulating hormone release from pituitary of domestic hen by means of progesterone. *Endocrinology*, **44**, 141-149.
- ROTHCHILD, I., AND KOH, N. K. 1951. The effects of a single preovulatory injection of progesterone on indices of ovulation in women. *J. Clin. Endocrinol.*, **11**, 789.
- RUBINSTEIN, H. S., AND KURLAND, A. A. 1941. The effect of testosterone propionate on the rat testis. *Endocrinology*, **28**, 495-505.
- RUMBACR, I. 1950. Beitrag zum Problem des zwischenhirn-Hypophysen-systems. (Untersuchungen an der Katze.) *Arch. path. Anat.*, **318**, 195-210.
- RUSSELL, D. S. 1956. Effects of dividing the pituitary stalk in man. *Lancet*, **1**, 466-468.
- SAMUELS, L. T. 1948. *Nutrition and Hormones*, W. O. Thompson, Ed. Springfield, Ill.: Charles C Thomas.
- SAMUELS, L. T. 1950. Relation of nutrition to the anterior pituitary. In *Progress in Clinical Endocrinology*, S. Soskin, Ed., pp. 509-517. New York: Grune and Stratton.
- SAVAGE, R. M. 1935. The influence of external factors on the spawning date and migration of the common frog, *Rana temporaria temporaria*.

- Linn. Proc. Zool. Soc., London, **1935**(1), 49-98.
- SAWYER, C. H. 1957. Induction of lactation in the rabbit with reserpine. *Abstr. Rec.*, **127**, 362.
- SAWYER, C. H., EVERETT, J. W., AND MARKEE, J. E. 1950. "Spontaneous" ovulation in rabbit following combined estrogen-progesterone treatment. *Proc. Soc. Exper. Biol. & Med.*, **74**, 185-186.
- SAYERS, G., AND BROWN, R. W. 1954. *The Adenohypophysis: Glandular Physiology and Therapy*. Philadelphia: J. B. Lippincott Company.
- SCHAEFFER, W. H. 1933. Hypophysectomy and thyroidectomy of snakes. *Proc. Soc. Exper. Biol. & Med.*, **30**, 1363-1365.
- SCHARRER, E., AND SCHARRER, B. 1945. Neurosecretion. *Physiol. Rev.*, **25**, 171-181.
- SCHARRER, E., AND SCHARRER, B. 1954a. Hormone produced by neurosecretory cells. *Recent Progr. Hormone Res.*, **10**, 183-232.
- SCHARRER, E., AND SCHARRER, B. 1954b. *Neurosekretion, Handbuch der Mikroskopischen Anatomie des Menschen*, Vol. 6, p. 953. Berlin: Springer-Verlag.
- SCHNICKEL, P. G. 1954. The effect of the presence of the ram on the ovarian activity of the ewe. *Australian J. Agric. Res.*, **5**, 465-469.
- SCHOOLEY, J. P. 1937. Pituitary cytology in pigeons. *Cold Spring Harbor Symposium Quant. Biol.*, **5**, 165-179.
- SCHWENK, E., FLEISCHER, G. A., AND TOLKSDORF, S. 1943. New method for preparation of prolactin. *J. Biol. Chem.*, **147**, 535-540.
- SEGAL, S. J. 1957. Response of weaver finch to chorionic gonadotrophin and hypophysial luteinizing hormone. *Science*, **126**, 1242-1243.
- SEGALOFF, A., STEELMAN, S. L., AND FLORES, A. 1956. Prolactin as a factor in the ventral prostate assay for luteinizing hormone. *Endocrinology*, **59**, 233-240.
- SELYE, H. 1934. On the nervous control of lactation. *Am. J. Physiol.*, **107**, 535-538.
- SELYE, H., AND FRIEDMAN, S. M. 1941. Action of various steroid hormones on testis. *Endocrinology*, **28**, 129-140.
- SHAY, H., GERSTON-COHEN, J., PASCHKIS, K. E., AND FELS, S. S. 1941. Inhibition and stimulation of testes in rats treated with testosterone propionate. *Endocrinology*, **28**, 485-494.
- SIEDLOVSKY, T., ROTHEN, A., GREEP, R. O., VAN DYKE, H. B., AND CHOW, B. F. 1940. The isolation in pure form of the interstitial cell-stimulating (luteinizing) hormone of the anterior lobe of the pituitary gland. *Science*, **92**, 178-180.
- SIELESNYAK, M. C., AND ROSEN, S. 1938. Nasogenital relationship: induction of pseudopregnancy in rat by nasal treatment. *Endocrinology*, **23**, 58-63.
- SHIRLEY, H. V., JR., AND NALBANDOV, A. V. 1956a. Effects of neurohypophysectomy in domestic chickens. *Endocrinology*, **58**, 177-183.
- SHIRLEY, H. V., JR., AND NALBANDOV, A. V. 1956b. Effects of transecting hypophysial stalks in laying hens. *Endocrinology*, **58**, 691-700.
- SIMPSON, M. E., EVANS, H. M., AND LI, C. H. 1950. Effect of pure FSH alone or in combination with chorionic gonadotropin in hypophysectomized rats of either sex. *Anat. Rec.*, **106**, 247-248.
- SIMPSON, M. E., LI, C. H., AND EVANS, H. M. 1942a. Biological properties of pituitary interstitial cell-stimulating hormone (ICSH). *Endocrinology*, **30**, 969-976.
- SIMPSON, M. E., LI, C. H., AND EVANS, H. M. 1942b. Comparison of methods for standardization of pituitary interstitial cell-stimulating hormone (ICSH). *Endocrinology*, **30**, 977-984.
- SIMPSON, M. E., LI, C. H., AND EVANS, H. M. 1951. Synergism between pituitary follicle-stimulating hormone (FSH) and human chorionic gonadotrophin (HCG). *Endocrinology*, **48**, 370-383.
- SIMPSON, M. E., AND VAN WAGENEN, G. 1953. Response of the ovary of the monkey (*Macaca mulatta*) to the administration of pituitary follicle-stimulating hormone (FSH). *Anat. Rec.*, **115**, 370.
- SIMPSON, M. E., VAN WAGENEN, G., AND CARTER, F. 1956. Hormone content of anterior pituitary of monkey (*Macaca mulatta*) with special reference to gonadotrophins. *Proc. Soc. Exper. Biol. & Med.*, **91**, 6-11.
- SMITH, O. W. 1944. The pituitary responses of mature male rats to an oxidation inactivation product of estrone. *Endocrinology*, **35**, 146-157.
- SMITH, O. W. 1945. Further studies on pituitary responses to oxidative inactivation product of estrone. *Proc. Soc. Exper. Biol. & Med.*, **59**, 242-246.
- SMITH, P. E. 1927. The disabilities caused by hypophysectomy and their repair. The tubercular (hypothalamic) syndrome in the rat. *J. A. M. A.*, **88**, 158-161.
- SMITH, P. E. 1939. The effect on the gonads of the ablation and implantation of the hypophysis and the potency of the hypophysis under various conditions. In *Sex and Internal Secretions*, 2nd ed., E. Allen, C. H. Danforth and E. A. Doisy, Eds., pp. 931-959. Baltimore: The Williams & Wilkins Company.
- SMITH, P. E. 1941. Maintenance and restoration of spermatogenesis in hypophysectomized rhesus monkeys by androgen administration. *Yale J. Biol. & Med.*, **17**, 281-287.
- SMITH, P. E. 1951. Continuation of pregnancy in rhesus monkeys (*Macaca mulatta*) following hypophysectomy. *Endocrinology*, **55**, 655-664.
- SMITH, P. E. 1955. The endocrine glands in hypophysectomized pregnant Rhesus monkeys (*Macaca mulatta*) with special reference to the adrenal glands. *Endocrinology*, **56**, 271-284.
- SMITH, P. E., AND DORTZBACH, C. 1929. The first appearance in the anterior pituitary of the developing pig fetus of detectable amounts of the hormone stimulating ovarian maturity and general body growth. *Anat. Rec.*, **43**, 277-297.
- SMITH, R. N. 1956. The presence of nonmyeli-

- nated nerve fibers in the pars distalis of the pituitary gland of the ferret. *J. Endocrinol.*, **14**, 279-283.
- SMITH, R. W., GAEBLER, O. H., AND LONG, C. N. H. 1955. *The Hypophysial Growth Hormone, Nature and Actions*. New York: McGraw-Hill Book Co.
- SQUIRE, P. G., AND LI, C. H. 1959. Purification and properties of interstitial cell-stimulating hormone from sheep pituitary glands. *J. Biol. Chem.*, **234**, 520-525.
- SREBNIK, H. H., AND NELSON, M. M. 1957. Increased pituitary gonadotrophic content in protein-deficient castrate rats. *Anat. Rec.*, **127**, 372.
- STEELMAN, S. L. 1958. Chromatography of follicle-stimulating hormone (FSH) on hydroxyl apatite. *Biochim. et Biophys. Acta*, **27**, 405-406.
- STEELMAN, S. L., KELLY, T. L., SEGALOFF, A., AND WEBER, G. F. 1956. Isolation of an apparently homogeneous follicle stimulating hormone. *Endocrinology*, **59**, 256-257.
- STEELMAN, S. L., LAMONT, W. A., AND BALTES, B. J. 1955. Preparation of highly active follicle-stimulating hormone from swine pituitaries. *Endocrinology*, **56**, 216-217.
- STEELMAN, S. L., LAMONT, W. A., AND BALTES, B. J. 1956. Preparation of highly active follicle stimulating hormone from swine pituitary glands. *Acta endocrinol.*, **22**, 186-190.
- STEELMAN, S. L., LAMONT, W. A., DITTMAN, W. A., AND HAWRYLEWICZ, E. J. 1953. Fractionation of swine follicle-stimulating hormone. *Proc. Soc. Exper. Biol. & Med.*, **82**, 645-647.
- STEELMAN, S. L., AND POHLEY, F. M. 1953. Assay of the follicle-stimulating hormone based on the augmentation with human chorionic gonadotropin. *Endocrinology*, **53**, 604-616.
- STEIN, K. F. 1935. A sex difference in gonad-stimulating potency of young gonadectomized rats. *Proc. Soc. Exper. Biol. & Med.*, **33**, 95-97.
- STROGANOV, N. S., AND ALPATOV, V. V. 1951. A new unit for determining the activity of the hypophysis in fish. [In Russian.] *Rybnoc Khoziastvo*, **27**, 56-60.
- STUTINSKY, F. 1948. Sur l'innervation de la pars tuberalis de quelques mammifères. *Compt. Rend. Acad. Sci. Paris*, **39**, 276-297.
- STUTINSKY, F. 1951. Sur l'origine de la substance Gomori-positive du complexe hypothalamo-hypophysaire. *Compt. rend. Soc. biol.*, **145**, 367-370.
- STUTINSKY, F. 1953. La neurosécrétion chez l'anguille normale et hypophysectomisée. *Zschr. Zellforsch. mikroskop. Anat.*, **39**, 276-297.
- STUTINSKY, F. 1957. Action de l'ocytocine exogène sur la production d'un décidome traumatique chez la ratte allaitante. (Effects of exogenous oxytocin on the production of a traumatic deciduoma in the lactating rat.) *Compt. rend. Acad. sc.*, **244**, 1537-1539.
- STUTINSKY, F., BONVALET, M., AND DELL, P. 1950. Les modifications hypophysaires au cours du diabète insipide expérimental chez le chien. *Ann. Endocrinol.*, **10**, 505-517.
- SWINGLE, W. W., SEAY, P., PERLHUTT, J., COLLINS, E. J., BARLOW, G., JR., AND FEDOR, E. J. 1951. An experimental study of pseudopregnancy in rat. *Am. J. Physiol.*, **167**, 586-592.
- SWYER, G. I. M. 1956. Hormones and human fertility. *Practitioner*, **176**, 632-640.
- SYDNOR, K. L. 1945. Time relationships of decidualoma formation in prolactin-treated and normal pseudopregnant rats. *Endocrinology*, **36**, 88-91.
- TABER, E., CLAYTON, M., KNIGHT, J., FLOWERS, J., GAMBRELL, D., AND AYERS, C. 1958. Some effects of sex hormones and homologous gonadotrophins on the early development of the rudimentary gonad in fowl. *Endocrinology*, **63**, 435-448.
- TABER, E., CLAYTON, M., KNIGHT, J., GAMBRELL, D., FLOWERS, J., AND AYERS, C. 1958. Ovarian stimulation in the immature fowl by desiccated avian pituitaries. *Endocrinology*, **62**, 84-89.
- TAKEWAKI, K., AND MAEKAWA, K. 1952. Effects of hormonal steroids on intrasplenic ovarian transplants in male and female rats. *Annot. Zool. Japon*, **25**, 403-410.
- TANG, P. C., AND PATTON, H. D. 1951. Effect of hypophysial stalk section on adenyohypophysial function. *Endocrinology*, **49**, 86-98.
- THOMPOUTOU, H., AND LI, C. H. 1954. Histological effect of pituitary gonadotrophins on the ovaries of immature Swiss white mice. *Acta endocrinol.*, **15**, 97-100.
- THOMSON, A. P. D., AND ZUCKERMAN, S. 1953. Functional relations of the adenyohypophysis and hypothalamus. *Nature, London*, **171**, 970.
- THOMSON, A. P. D., AND ZUCKERMAN, S. 1954. The effect of pituitary-stalk section on light-induced oestrus in ferrets. *Proc. Roy. Soc. London, ser. B*, **142**, 437-451.
- THORBERG, J. V., AND HANSEN, K. 1951. The use of *Zenopus lacustris*, *Bufo bufo*, and *Rana esculenta* as test animals for gonadotrophic hormones. III. Quantitative investigations on the sensitivity of the animals to chorionic gonadotrophin. *Acta endocrinol.*, **6**, 51-66.
- TOBIN, C. E. 1942. Effects of lactogen on normal and adrenalectomized female rats. *Endocrinology*, **31**, 197-200.
- TRUSCOTT, B. L. 1944. Nerve supply to the pituitary of the rat. *J. Comp. Neurol.*, **80**, 235-255.
- ULBERG, L. C., CHRISTIAN, R. E., AND CASIDA, L. E. 1951. Ovarian response in heifers to progesterone injection. *J. Anim. Sci.*, **10**, 752-759.
- VAN DER KUY, A., VAN SOEST, E. M., AND VAN PROOYBELLE, A. G. C. 1953. On the standardization of prolactin. *Konink. Nederl. Akad. Wetensch.*, **56**, 62-65.
- VAN DYKE, H. B. 1939. *The Physiology and Pharmacology of the Pituitary Body*, Vol. II. Chicago: University of Chicago Press.
- VAN DYKE, H. B., PAN, S. Y., AND SHEBLOVSKY, T. 1950. Follicle-stimulating hormones of the anterior pituitary of the sheep and the hog. *Endocrinology*, **46**, 563-573.
- VAN WAGENEN, G. 1949. Accelerated growth with sexual precocity in female monkeys receiving

- testosterone propionate. *Endocrinology*, **45**, 544-546.
- VAZQUEZ-LOPEZ, E. 1949. Innervation of the rabbit adenohipophysialis. *J. Endocrinol.*, **6**, 158-169.
- VAZQUEZ-LOPEZ, E. 1953. The structure of the rabbit neurohypophysis. *J. Endocrinol.*, **9**, 30-41.
- VAZQUEZ-LOPEZ, E., AND WILLIAMS, P. C. 1952. Nerve fibres in the adenohipophysialis under normal and experimental conditions. *Ciba Foundation Colloquia Endocrinol.*, **4**, 54-63.
- VAUGHEN, L. 1951. Ponte induite chez la perruche ondulée maintenue à l'obscurité et dans l'ambiance des volières. *Compt. rend. Acad. sc.*, **232**, 1706-1708.
- VELARDO, J. T. 1958. Induction of pseudopregnancy in adult rats with Trilafon, a highly potent tranquilizer of low toxicity. *Fertil. & Steril.*, **9**, 60-66.
- WALSH, E. L., CUYLER, W. K., AND McCULLAGH, D. R. 1934. Physiologic maintenance of male sex glands; effect of androten on hypophysectomized rats. *Am. J. Physiol.*, **107**, 508-512.
- WARKANY, J., AND SCHRAFFENBERGER, E. J. 1944. Congenital malformations induced in rats by maternal nutritional deficiency; preventive factor. *J. Nutrition*, **27**, 477-484.
- WARWICK, E. J. 1946. Gonadotrophic potency of ewe pituitary glands affected by spaying season and breed. *Proc. Soc. Exper. Biol. & Med.*, **63**, 530-533.
- WELLS, L. J. 1935. Seasonal sexual rhythm and its experimental modification in the male of the thirteen-lined ground squirrel. *Anat. Rec.*, **62**, 109-117.
- WELLS, L. J. 1943. Effects of large doses of androgen on the testis in the ground squirrel *Citellus tridecemlineatus*. *Endocrinology*, **32**, 455-462.
- WELLS, L. J. 1956. Effect of fetal endocrines on fetal growth. *Macy Foundation Conferences on Gestation*, **3**, 187-227.
- WELLS, L. J., AND ZALESKY, M. 1949. Effect of low environmental temperature on the reproductive organs of male mammals with annual aspermidia. *Am. J. Anat.*, **66**, 429-447.
- WERNER, S. C. 1939. Failure of gonadotropic function of rat hypophysis during chronic inanition. *Proc. Soc. Exper. Biol. & Med.*, **41**, 101-105.
- WESTMAN, A., AND JACOBSSON, D. 1940. Endokrinologische Untersuchungen an Kaninchen mit durchtrenntem Hypophysenstiel. *Acta obst. gynec. scandinav.*, **20**, 392-433.
- WESTMAN, A., JACOBSSON, D., AND HILLARP, N. A. 1943. Über die Bedeutung des Hypophysenzwischenhirnsystems für die Produktion gonadotroper Hormone. *Monatsschr. Geburtsh. Gynäk.*, **116**, 225-250.
- WHITE, A. 1943. The lactogenic hormone and mammary. *Ann. New York Acad. Sc.*, **43**, 309-382.
- WHITE, A. 1949. The chemistry and physiology of adenohipophysial luteotropin (Prolactin). *Vitamins & Hormones*, **7**, 254-294.
- WHITE, A., CATCHPOLE, H. R., AND LONG, C. N. H. 1937. Crystalline protein with high lactogenic activity. *Science*, **86**, 82-83.
- WHITELAW, J. M. 1956. Delay in ovulation and menstruation induced by chlorpromazine. *J. Clin. Endocrinol.*, **16**, 972.
- WHITTEN, W. K. 1956a. The effect of removal of the olfactory bulbs on the gonads of mice. *J. Endocrinol.*, **14**, 160-163.
- WHITTEN, W. K. 1956b. Modification of the oestrous cycle of the mouse by external stimuli associated with the male. *J. Endocrinol.*, **13**, 399-404.
- WILHELM, A. 1955. Comparative biochemistry of growth hormone from ox, sheep, pig, horse, and fish pituitaries. In *The Hypophysial Growth Hormone Nature and Actions*, R. W. Smith, O. H. Gaebler, and C. N. H. Long, Eds., pp. 59-69. New York: McGraw-Hill Book Company.
- WILLIAMS, P. C. 1940. Effect of stilboestrol on the ovaries of hypophysectomized rats. *Nature*, London, **145**, 388-389.
- WILLIAMS, S. M., GARRIGES, U. S., NORTON, H. W., AND NALBANDOV, A. V. 1956. The occurrence of estrus in pregnant ewes. *J. Anim. Sc.*, **15**, 978-983.
- WILLS, I. A., RILEY, G. M., AND STUBBS, E. M. 1933. Further experiments on the induction of ovulation in toads. *Proc. Soc. Exper. Biol. & Med.*, **30**, 781-786.
- WILTBERGER, P. B., AND MILLER, D. F. 1948. The male frog, *Rana pipiens*, as a new test animal for early pregnancy. *Science*, **107**, 498.
- WINGSTRAND, K. G. 1951a. *The Structure and Development of the Avian Pituitary from a Comparative and Functional Viewpoint*. Lund: Hakan Ohlssons Boktryckeri.
- WINGSTRAND, K. G. 1951b. The structures in the avian pituitary responsible for the transfer of impulses from the nervous to the hormonal system. In *Proceedings International Ornithological Congress*, Vol. 10, p. 645. Uppsala and Stockholm: Almqvist and Wikells.
- WISLOCKI, G. B., AND KING, S. L. 1936. The permeability of the hypophysis and hypothalamus to vital dyes with a study of the hypophysial vascular supply. *Am. J. Anat.*, **58**, 421-472.
- WITSCHL, E. 1937. Comparative physiology of the vertebrate hypophysis (anterior and intermediate lobes). *Cold Spring Harbor Symposia Quant. Biol.*, **5**, 180-190.
- WITSCHL, E. 1940. The quantitative determination of follicle-stimulating and luteinizing hormones in mammalian pituitaries and a discussion of the gonadotropic quotient. *F. L. Endocrinology*, **27**, 437-446.
- WITSCHL, E. 1952. Gonadotropins of the human hypophysis, particularly in old age. *J. Gerontol.*, **7**, 307.
- WITSCHL, E. 1955. Vertebrate gonadotropins. In *Comparative Physiology of Reproduction, Memoirs of the Society for Endocrinology*, No.



- I. I. Chester Jones and P. Eckstein, Eds. London: Cambridge University Press.
- WITSCHI, E., AND RILEY, G. M. 1940. Quantitative studies on the hormones of human pituitaries. *Endocrinology*, **26**, 565-576.
- WOLFE, J. M., AND HAMILTON, J. B. 1937. Comparative action of testosterone compounds of estrone and of combination of testosterone compounds and estrone on anterior hypophysis. *Endocrinology*, **21**, 603-610.
- WOOTEN, E., NELSON, M. M., SIMPSON, M. E., AND EVANS, H. M. 1955. Effect of pyridoxine deficiency on the gonadotrophic content of the anterior pituitary in the rat. *Endocrinology*, **56**, 59-66.
- WRIGHT, P. A., AND HISAW, F. L. 1946. Effects of mammalian pituitary gonadotropins on ovulation in the frog, *Rana pipiens*. *Endocrinology*, **39**, 247-255.
- XUEREB, G. P., PRICHARD, M. M. L., AND DANIEL, P. M. 1954a. The hypophysial portal system of vessels in man. *J. Exper. Physiol., London*, **39**, 219-229.
- XUEREB, G. P., PRICHARD, M. M. L., AND DANIEL, P. M. 1954b. The arterial supply and venous drainage of the human hypophysis cerebri. *J. Exper. Physiol., London*, **39**, 199-217.
- YOUNG, W. C., AND YERKES, R. M. 1943. Factors influencing the reproductive cycle in the chimpanzee; the period of adolescent sterility and related problems. *Endocrinology*, **33**, 121-154.
- ZAWADOWSKY, M. M. 1941. Hormonal stimulation of multiple births in sheep. Cited by J. Hammond in *Marshall's Physiology of Reproduction*, A. S. Parkes, Ed. Vol. II, Ch. 21, 1952. London: Longmans, Green and Company.
- ZEPHIROFF, P., DROSDOVSKY, C., AND DOBROVOLSKAYA-ZAWADSKAYA, N. 1940. Presence d'une substance oestrogène dans les ovaires des animaux impubères (veaux). *Compt. rend. Soc. biol.*, **133**, 236-238.
- ZUBIRÁN, S., AND GÓMEZ-MONT, F. 1953. Endocrine disturbances in chronic human malnutrition. *Vitamins & Hormones*, **11**, 97-132.
- ZUCKERMAN, S. 1952. The cellular components of the ovary. *Proc. Soc. Study Fertil.*, **4**, 4.
- ZUCKERMAN, S. 1954. The secretions of the brain: relation of hypothalamus to pituitary gland. *Lancet*, **266**, 789-795.
- ZUCKERMAN, S. 1955. The possible functional significance of the pituitary portal vessels. *Ciba Foundation Colloquia Endocrinol.*, **8**, 551-586.



SECTION C

---

*Physiology of the Gonads  
and Accessory Organs*



# 5

## THE MAMMALIAN TESTIS

*A. Albert, Ph.D., M.D.*

PROFESSOR OF PHYSIOLOGY, MAYO FOUNDATION, AND HEAD OF  
THE ENDOCRINOLOGY LABORATORY, MAYO CLINIC,  
ROCHESTER, MINNESOTA

I. INTRODUCTION	305
II. POSTNATAL DEVELOPMENT OF THE TESTIS	307
III. DESCENT OF THE TESTIS	309
IV. BREEDING PATTERNS	315
V. ARCHITECTURE OF THE TESTIS	317
VI. THE CIRCULATORY SYSTEM OF THE TESTIS	318
VII. THE NERVOUS SYSTEM AND THE TESTIS	321
VIII. THE EXCRETORY DUCT SYSTEM	323
IX. THE SEMINIFEROUS EPITHELIUM	323
X. THE INTERSTITIAL TISSUE	329
XI. HORMONES OF THE TESTIS	332
XII. EFFECTS OF THE PITUITARY ON THE TESTIS	335
XIII. EFFECTS OF STEROIDS ON THE TESTIS	337
A. Androgens	338
B. Estrogens	343
C. Adrenal Steroids	344
D. Miscellaneous Steroids and Mixtures of Steroids	345
XIV. EFFECTS OF ALTERED ENDOCRINE STATES ON THE TESTIS	346
XV. NONNEOPLASTIC DISORDERS OF THE TESTIS	348
XVI. TUMORS OF THE TESTIS	349
XVII. CONCLUSION	351
XVIII. REFERENCES	353

### I. Introduction

The function of the testis is concerned with the preservation of the species. It accomplishes this by producing sperm and hormones. The tubular apparatus is responsible for the manufacture of sperm, and the interstitial tissue gives rise to the hormones. These two compartments are intimately associated with one another embryologically, anatomically, and functionally. Furthermore, they are controlled by separate gonadotrophic hormones of the anterior pituitary. In turn, the secretion and me-

tabolism of the pituitary gonadotrophins are controlled by the tubules and the Leydig cells. Knowledge of this reciprocal control of pituitary-testis activity was well established by 1940; in general, this reciprocity is the basic frame of reference for the interpretation of all aspects of testicular function. More intimate relationships are quite complex and, as will be seen, not completely understood.

It would be gratifying to interpret all aspects of the testis within this fundamental frame of reference. This is not possible at present because the literature is too conflicting and no one has a sufficiently broad experience with testicular endocrinology to sit all of this literature competently. The extreme scatter of literature on the testis furnishes ample evidence for the discontinuity and heterogeneity of effort. Perhaps the main service of this chapter is the compilation in broad categories of the heterogeneous literature of the past 20 years, so that the student may have a handy, albeit incomplete, guide to the subject and to several of the major problems. A preview of the material to be discussed follows.

This chapter pertains to the testis in postnatal life. Acquaintance with the principal facts of the embryology of the testis and with recent developments in fetal endocrinology of the testis is presumed. Only a short description of the postnatal development of the testis is given because encyclopedic coverage is to be expected in other treatises, and because the acquisition of further details of the postnatal development of the testis in various species belongs

more to the domain of comparative morphology. The basic lessons already have been learned from a few species, and only the provision of an unusual specimen for study could be expected to aid the endocrinologist.

Interest in the effects of cryptorchism has shifted in the 20 years following Moore's (1939) summary in the second edition of this book; at that time, the main interest in the cryptorchid testis was in its capacity for hormonal production. At present, the chief concern is with its capacity for spermatogenic function. Despite some labor and much discourse, the treatment of cryptorchism in the human is not satisfactory. Controlled methods of management based on a reasonable working hypothesis have not been evolved, so that a definitive evaluation of results in terms of fertility is impossible.

The architecture of the testis has been described in terms of structural pattern and composition adapted for the formation and transport of sperm and for hormonal production. The influences of the circulatory and the nervous systems on testicular function have received uneven consideration. The former system is essential for testicular function; not only does it bring the necessary gonadotrophic hormones to the testis but, just as important, it provides food-stuffs and oxygen and carries away metabolites. The testis is extremely sensitive to derangement of its blood supply. The peripheral nervous system, however, appears to be relatively unimportant to the post-natal well-being of the testis.

The compartments of the testis are discussed in two sections of this chapter. The germinal epithelium produces sperm, and it is with regard to this compartment that major advances have been made. Quantitative cytologic studies have unraveled the spermatogenic cycle and have provided detailed information on spermiogenesis. These studies are tedious and require painstaking techniques, but there is at present no other way to obtain quantitative information.

The hormonal compartment of the testis has been further clarified by morphologic methods, but the greatest advances have been made by chemists. The biogenesis of male hormone has been worked out and is

discussed in detail in the chapter by Vilee. So far, the hormones manufactured by the testis have been shown to include only steroids. A flare of interest in a water-soluble hormone, namely inhibin, was short-lived, and this issue has been dormant in the past decade.

The next two sections of this chapter, the control of the testis by the pituitary, and the effects of male hormone and other steroids on the testis are representative of classic endocrinology. The dual concept of testicular control by means of follicle-stimulating hormone (FSH) and luteinizing hormone (LH) for the tubular apparatus and the Leydig cells, respectively, is less secure than it was believed to be in 1939. Interest in the fractionation of pituitary gonadotrophins waned in the 1940's, and investigators were unable to obtain purified FSH and LH for experimental study. Furthermore, the discovery that testosterone and other steroids maintained spermatogenesis in the complete absence of gonadotrophins became an irritant to the dualist's composure. Intensive effort in this area has removed some difficulties, but it has not solved the problems. Recent studies have shown that male hormone is needed for spermiogenesis and gonadotrophins for copious spermatogenesis, but there the problem rests.

The effect of alterations in the endocrine system on the testis is discussed briefly. Extremely little has been done in this area except for the influence of altered thyroidal states. As will be seen, the thyroid can exert some influence on testicular function, but this depends largely on the species studied. Further understanding will evolve as more species are studied.

The last sections in the chapter deal with disorders and tumors of the testis. Disorders of the testis, chiefly hypogonadal states, are important in both veterinary and clinical medicine. Study of some of these disorders has greatly clarified normal physiology. A brief survey will be given of this aspect to emphasize the pituitary regulation of testicular function as shown by the effects of certain spontaneous disorders of the pituitary. Brief mention will also be made of the awareness of the increasing importance of genic factors and of the fetal

endocrine system in basic and clinical problems of the testis. The inherited types of infertility in males seem to be an especially rewarding field of investigation. Spontaneous tumors of the testis supply interesting and instructive material for study in both clinical and veterinary medicine. Tumors induced in the testis by experimental means have contributed nothing unique to the problem of oncogenesis. They have, however, provided material for the concept of "hormonal dependence" of certain tumors; therefore, they are of importance in the field of cancer.

Not included in this review are studies on the effects of nutritional deficiency, of radiation, and toxic substances on the testis. The first is discussed in detail in the chapter by Leatham. The second has been purposely omitted because it belongs more to the sphere of interest of the radiation biologist than to that of the endocrinologist. It must not be forgotten, however, that knowledge of the relative sensitivity of the various cells of the testis to injury, the first quantitative information on the spermatogenic cycle, and the mechanism of repopulation of the germinal epithelium after severe damage were contributions of the radiation biologist. The third is a hodgepodge of material which at present defies orderly condensation. Despite this, some of the studies in this area are of potential value in providing unique experimental preparations, *i.e.*, animals with testes containing only Leydig cells, or only Sertoli cells. Finally, a miscellany of papers dealing with the general physiology or with the general biochemistry of the testis has also been omitted.

## II. Postnatal Development of the Testis

In the past 20 years, voluminous descriptive information has been compiled on the events and consequences of the postnatal development of the testis of mammals. Only a few examples will be given. The developmental anatomy and postnatal changes in the testis of the laboratory rat have been described. Various monographs on the rat (Farris and Griffith, 1949, for references) and Moore's chapter in the 1939 edition are available.

The testis of the guinea pig has a growth spurt about the 20th day of life. The accessory sex structures, such as the vas deferens, epididymis, and prostate, are stimulated somewhat later, at 30 to 40 days. The growth of these accessory organs is an indication of male hormone activity. The time at which hormonal secretion occurs varies among individual animals. Variability (48 to 70 days) occurs also in the appearance of sperm (Sayles, 1939). Under controlled conditions of breeding, Webster and Young (1951) observed that the first intromission in guinea pigs occurs at about 54 days of age. The first ejaculate occurs some 10 days later and is sterile. Fertile ejaculates begin on the average at 82 days of age. Thus, a period of adolescent sterility exists as the result of both lack of ejaculation and a period when there is an insufficiency of spermatozoa. The hamster (Bond, 1945) copulates at 30 days of age but is not fertile until 43 days of age. Adolescent sterility of the male may be a more common phenomenon than is generally appreciated.

The testes of the cat are descended at birth. Testicular growth is slow, the combined weight of the two testes increasing from 20 mg. at birth to 100 mg. at weaning. During the 2 months following weaning, the testes attain a weight of 130 mg. A spurt in growth occurs between the third and the fifth month of life, when the testes may weigh 500 mg. This spurt is associated with the appearance of Leydig cells and an increase in the size of the epididymis. Mitotic activity of the germinal epithelium is present in testes weighing 400 to 500 mg. Spermatisids appear when the testes weigh 700 mg., and sperm are found fairly uniformly when the testes are more than 1 gm. in weight. At this stage, the tubular diameter is maximal. After maturity, the weight of the testes is generally proportional to body weight. A 5-kg. cat will have testes weighing 4 gm. (Scott and Scott, 1957).

From birth to 80 days of age, the testes of goats grow at a slow but uniform rate. In the immature animal, the tubules are small, measuring 30  $\mu$  in diameter, and are composed of a single layer of cells without any lumen. The interstitial tissue contains only mesenchymal cells. At 90 days of age,

a lumen appears in the tubules and spermatogenesis begins. At 94 days, maturation of the Leydig cells is noted, and spermiogenesis occurs. The diameter of the tubules at maturity is about  $100 \mu$ , but the tubule continues to increase to about  $160 \mu$  when the goat is 135 days of age. Formation of sperm occurs earlier in goats than in rams, bulls, and boars (Yao and Eaton, 1954).

As in common laboratory animals, the time sequence in the testicular maturation of farm animals is determined by genic factors, which obviously is an important phenomenon economically. In different strains of the ram, for instance, there is a variation of 5 weeks in the time of appearance of primary spermatocytes, of 9 weeks in the appearance of secondary spermatocytes, and of 2 weeks for spermatids (Carmon and Green, 1952).

Among the primates, postnatal development has been studied intensely in the monkey and man. In the rhesus monkey (Fig. 5.1), the tubules attain a diameter of 70 to  $80 \mu$  during fetal life (van Wageningen and Simpson, 1954). Only spermatogonia and Sertoli cells containing basal nuclei are present. Mature Leydig cells are also identifiable. Shortly after birth, regression occurs in the tubules, which decrease to a diameter of 50 to  $60 \mu$ , and in the Leydig cells, which dedifferentiate into mesenchymal cells. The presence of mature Leydig cells and of differentiated Sertoli cells in the fetal testis

and their involution shortly after birth may be related to the secretion of a fetal morphogenic substance (*cf.* chapter by Burns).

During the first year after birth, the few spermatogonia increase in number and size. During the second year, they become more numerous and the tubules increase in length. However, the germinal epithelium remains quiescent until late in the third year. At this time, the Sertoli cells increase in number and differentiate. The Leydig cells mature again. The tubular diameter now is about  $100 \mu$ . A lumen appears when the tubules are 100 to  $150 \mu$  in diameter. Spermatids appear, and orderly spermatogenesis occurs. The prepubertal period in the monkey is about a fifth that of man; except for the factor of time, the sequence of development in the monkey testis resembles that in man (Figs. 5.2 and 5.3). In the pubertal monkey Leydig cells and tubules are stimulated simultaneously. Some observers have reported that maturation of Leydig cells occurs after tubular maturation in humans (Sniffen, 1952; Albert, Underdahl, Greene and Lorenz, 1953a) and in bulls (Hooker, 1948). However, this point may depend on the choice of the criteria for tubular stimulation (tubular wall *versus* germinal epithelium) and for function of Leydig cells (morphologic differentiation *versus* secretory activity).

Some interesting details on the relative

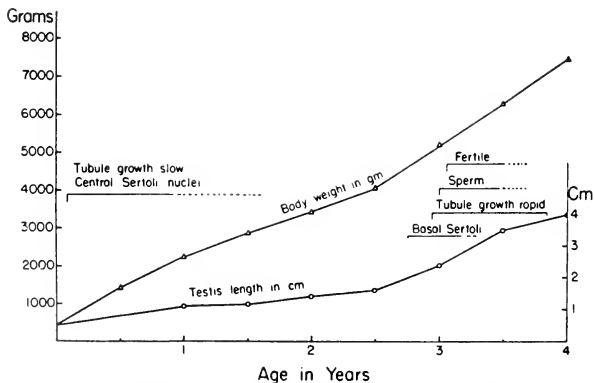

FIG. 5.1. Graphic representation of changes in testes of the rhesus monkey during development. Coordinates are body weight and age of animals, and length of testes. (From G. van Wageningen and M. E. Simpson, *Anat. Rec.*, **118**, 231, 1954.)



weight of the testis in primates have been supplied by hunting and scientific expeditions. Schultz (1938) studied 87 adult primates. The relative testicular weights (testicular weight divided by body weight  $\times 100$ ) varied between 0.1 and 0.4 in American monkeys. Considerably more variation was seen in Old World monkeys. The relative weight in five species of macaques varied between 0.46 and 0.92, but in langurs was only 0.06. The weight ratio in the orangutan was 0.05, in the gibbon and man 0.08, and in the chimpanzee, 0.27. Rough estimations of the ratio of the volume of interstitial tissue to tubular volume showed that the macaque has a greater relative volume of interstitial tissue than man. Testicular weights vary according to race; Japanese men have smaller testes than American men (Schonfeld, 1943).

The human testis at birth consists of small tubules measuring 50 to 75  $\mu$  in diameter and arranged in cords containing several rows of darkly staining nuclei. The epithelium is mostly undifferentiated, but large cells with sharp boundaries are present. These are primary germ cells. The interstitium of the testis is highly developed and contains solidly packed Leydig cells. After birth the Leydig cells disappear from the interstitium in a matter of a few weeks. From this time, the testis remains generally quiescent until puberty, when Leydig cells reappear as a result of the secretion of gonadotrophin. Only mesenchymal cells resembling fibroblasts characterize the interstitium in the period from a few weeks after birth until puberty. The germinal cords acquire a lumen at approximately 6 years of age, although this landmark shows considerable variation. The nuclei of the germinal cells at this time are arranged in two layers.

At puberty, which may occur at any age from 9 to 19 years, a great increase in size and tortuosity of the tubules occurs. The lamina propria develops, the Sertoli cells become differentiated, and the seminiferous epithelium gradually matures. The Leydig cells mature somewhat later than the changes noted in the tubules and become characteristically arranged in groups in the intertubular zones.

After maturity is attained, the adult his-

tologic pattern may be maintained into old age without pronounced changes. Spermatogenic activity varies from tubule to tubule, but an over-all picture shows spermatogenesis proceeding in an orderly fashion, with sperm heads closely approximating the luminal end of the Sertoli cells. About two-thirds of the tubule is occupied by the germinal epithelium. The lumen makes up about 15 per cent of the tubule. The proportionate volumes for the germinal cells are as follows: spermatogonia, 24 per cent; spermatocytes, 45 per cent; spermatids and spermatozoa, 29 per cent; various abnormal cells, 2 per cent. The Sertoli cells occupy about one third of the tubular epithelium. The Leydig cells occupy 9 per cent of the total intertubular spaces. About 66 per cent of the human adult testis is composed of tubules and about 22 per cent is made up of the intertubular spaces (Table 5.1). With age, progressive fibrosis occurs in the human testis, the width of the tubular wall increases, and thinning of the germinal epithelium occurs (Sniffen, 1952; Charny, Constin and Meranze, 1952; Albert, Underdahl, Greene and Lorenz, 1953b; de la Balze, Bur, Scarpa-Smith and Irazu, 1954; Roosen-Runge, 1956).

### III. Descent of the Testis

The descent of the testis from an abdominal position in the fetus was known to the ancients (Badenoch, 1945). This change in position is a mammalian phenomenon. In the *Monotremata* and most of the *Edentata*, the testes are abdominal. Some of the *Insectivora*, *Cetacea*, and *Sirenia* also have abdominal testes. The testes in marsupials lie suprapubically in a pouch that has a closed vaginal process. The testes of *Apodontia rufa*, the most primitive rodent extant, occupy a semiscrotal position during the breeding season; otherwise, the testes are abdominal (Pfeiffer, 1956). In some rodents, *Insectivora* and *Chiroptera*, the testes are intra-abdominal in the resting stage, but during the rutting season they are pulled into the scrotum by muscles. In the *Ungulata*, *Carnivora*, and *Primates*, the testes are extra-abdominal. Exceptions are the elephant and stag, whose testes are retracted in the nonrutting season. Thus, "cryptorchism" is normal for many mammals, and

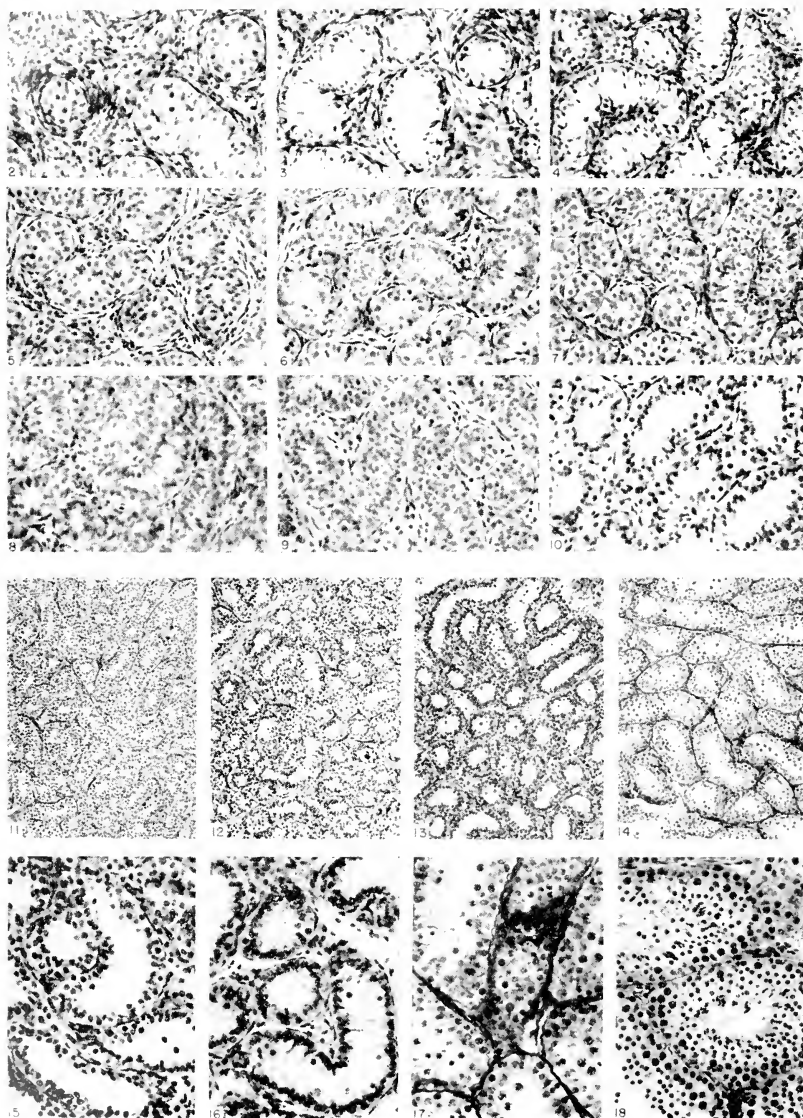

FIG. 52. Developmental stages in the monkey testis

2. Testis of a 96-day fetus. Tubules are short and straight; diameter is 60 to 70  $\mu$ . Only Sertoli cells and a few spermatogonia are present in tubules. Sertoli cells are large and fill the lumen. Intertubular spaces are wide and contain many cells, some epithelioid.

3. Biopsy of testis at birth (174-day gestation). Tubular diameter is 60 to 80  $\mu$ . Nuclei of Sertoli cells are basal, and cytoplasmic strands fill tubular lumen. Spermatogonia are sparse. Intertubular tissue is abundant but undifferentiated.

the term should be restricted to designate an abnormal testicular position in those species whose testes normally are scrotal. In such species, cryptorchism of sufficient duration results in an irreversible loss of spermatogenic function and in a variable failure of hormonal function.

In most animals the testicular temperature afforded by the scrotum is 1 to 8°C. lower than the body temperature. In man the testicular temperature is 1.5 to 2.5°C. lower than the temperature of the abdomi-

nal cavity. Early work by Moore (reviewed by Moore, 1951) showed that the testes of rats, rabbits, and guinea pigs become atrophic within a few weeks when placed in the abdominal cavity. Moore wrapped the testes of the ram with wool batting, with the result that the ram was sterilized by its own body heat. The application of water 5°C. above body temperature to the scrotum of guinea pigs causes temporary sterility. The deleterious effects of increased temperature also are observed in man. Fever, dia-

4. Testis at 3 months. More coiling of tubules is present; diameter is 50 to 60  $\mu$ . Cytoplasm of Sertoli cells is developed and still fills the lumen. A few spermatogonia are present. Intertubular spaces are narrow and interstitial cells have regressed.

5. Testis at 3 months and 25 days. Considerable increase in length, with coiling of tubules, has occurred. Tubules are small (50 to 60  $\mu$ ), compact, and filled with the Sertoli nuclei. There are occasional spermatogonia. The peritubular arrangement of dark-stained nuclei of intertubular tissue is clearly seen.

6. Testis at 4 months and 24 days. Tubules are small and closely packed. The size has not changed (50 to 60  $\mu$ ). The Sertoli nuclei fill the lumen, only occasional spermatogonia being seen.

7. Testis at 1 year, 3 months, 24 days. Tubules are still small (40 to 50  $\mu$ ). Spermatogonia are now increased in number and size. Nuclei of undifferentiated cells fill the lumen. Only dark-stained nuclei in rows around tubules are seen in narrow peritubular spaces.

8. Testis at 1 year, 8 months, 7 days. Tubules are still small (50  $\mu$ ). The Sertoli nuclei continue to crowd the lumen. Intertubular tissue is undifferentiated.

9. Testis at 2 years, 7 months, 6 days. Note that during an entire year no appreciable advance in development has occurred except in multiplication of the Sertoli nuclei and a slight increase in tubular diameter (60 to 70  $\mu$ ). Some of the interstitial cells are now lighter staining.

10. Testis at 2 years, 9 months, 21 days. Tubules are now definitely larger (90  $\mu$ ). Sertoli cells have moved to the periphery of the tubule. Spermatogonia are numerous and rounded. Rounded Leydig cells are now frequently seen.

11. Right testicular biopsy at 2 years, 4 months, 11 days. Tubules are long, convoluted, and closely packed, measuring 50 to 70  $\mu$  in diameter. Sertoli cells are poorly differentiated, but the cytoplasm is increasing and the nuclei have partially moved basally. Interstitial cells are small and sparse.

12. Right testicular biopsy at 2 years, 9 months, 16 days. The changes are slight. Tubules are somewhat larger (70  $\mu$ ) and the Sertoli nuclei are more basal. No differentiation of the Leydig cells is seen.

13. Right testicular biopsy at 3 years, 1 month, 26 days. Tubules have increased slightly in diameter (80 to 90  $\mu$ ). The Sertoli nuclei are now definitely basal. A few cells, recognizable as spermatocytes I by the spireme, are present. Interstitial cells are still not clearly recognizable.

14. Left testis at 3 years, 2 months, 14 days. Tubules measure 100 to 120  $\mu$ . Many spermatocytes are now present. Canalization is seen in a few tubules. A few epitheloid Leydig cells are present singly or in pairs.

15. Testicular biopsy at 2 years, 7 months, 14 days. Tubules measure 70  $\mu$ . The Sertoli nuclei are basal. A few desquamating cells are present in the meshes of the Sertoli cytoplasm. Occasional Leydig cells are recognizable.

16. Testicular biopsy at 3 years and 17 days. Tubules measure 70 to 80  $\mu$ . The Sertoli nuclei are basal. Vascularity has increased, and more space is present between tubules. Epitheloid Leydig cells are present, although not of mature size. Spermatocytes are appearing.

17. Left testis at 3 years, 2 months, 14 days. Tubules measure 100 to 120  $\mu$ . Formation of spermatocytes I is abundant.

18. Testicular biopsy at 3 years, 5 months, 28 days. Tubules measure 130 to 150  $\mu$ . Many spermatids and some sperm cells are present. Some desquamation of immature cells is still present in the tubular lumen. (From G. van Wagenen and M. E. Simpson, *Anat. Rec.*, **118**, 231, 1954.)

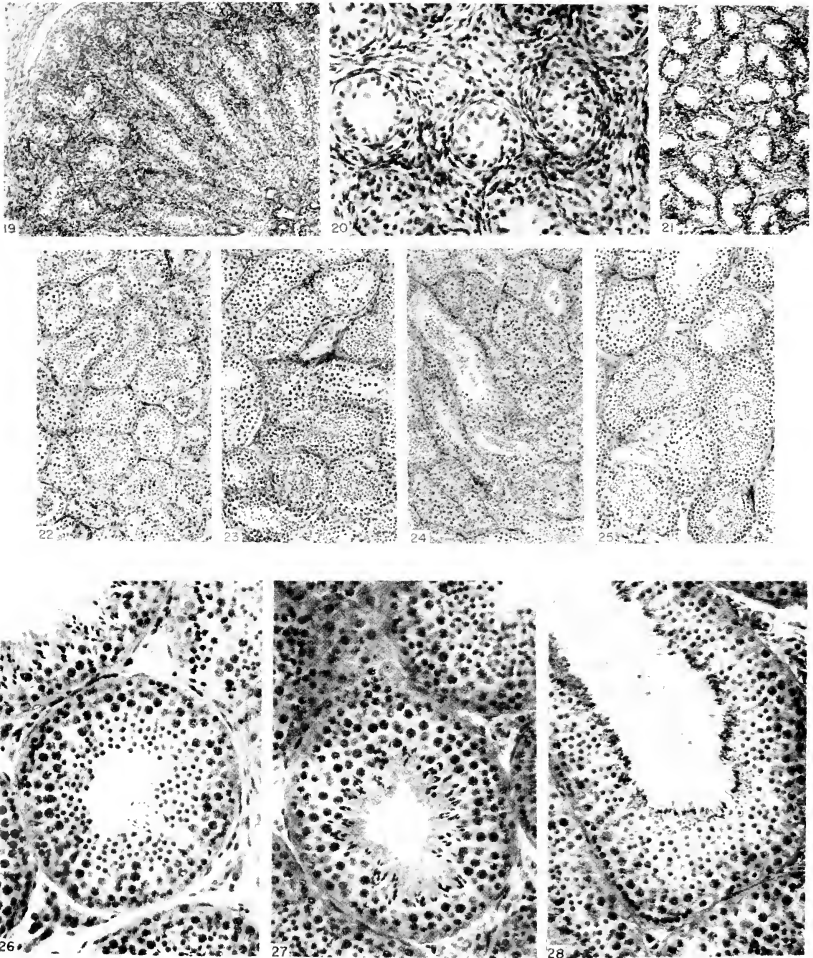

Fig. 5.3. Developmental stages in the monkey testis (continued from Figure 5.2)

19. Testis of 110-day fetus. Note short, uncoiled tubules, with a diameter of 70 to 80  $\mu$ . Cytoplasm of Sertoli cells is well developed and largely fills the lumen. The broad intertubular spaces contain abundant cells, many of which are enlarged and rounded.

20. Testis of 110-day fetus. This shows tubules in cross section. The orientation of the interstitial tissue concentrically around the tubules and the enlargement of the cells within the concentric rings are evident.

21. Testis at birth after a 174-day gestation. Note the Sertoli nuclei remaining in a basal position and the persistent wide intertubular space; however, the size of the Leydig cells has decreased.

22. Right testis at 2 years, 10 months, 3 days. Tubular diameter is 100 to 120  $\mu$ . Spermatids have differentiated to presperm cells or almost mature sperm cells. Great amounts of cellular debris fill the lumen. Few Leydig cells are differentiated.

23. Right testis 1 month later, at 2 years, 11 months, 1 day. Tubular diameter is 100 to 110  $\mu$ . Sperm cells are present.

thermy, or heating of the testes by other methods produces temporary depression of the sperm count (see Hotelkiss, 1944b, for review). These experiments support the concept of the thermoregulatory function of the scrotum. These studies also indicate that spermatogenesis in mammals can proceed only at an optimal temperature.

Cryptorchism in man has received considerable attention because it is a common clinical problem. The incidence of cryptorchism in man is given as 10 per cent at birth, 2 per cent at puberty, and 0.2 per cent at maturity (Nelson, 1953). The testis of man develops between the adrenal glands medially and the body wall laterally, ventral to the metanephros, and in the 20-mm. fetus is not far from the groin. The gubernaculum develops from the plica inguinalis and attaches to a pocket of the abdominal wall which forms the vaginal process (Wyndham, 1943). At the 2nd month of fetal life, the testis is elongated, extending from the diaphragm to the site of the future abdominal inguinal ring. By the 3rd month, the cranial end of the testis undergoes involution. By the 4th to the 7th month, the testis is in the iliac fossa near the internal ring. Descent occurs in the seventh month, and the testis becomes scrotal during the 8th fetal month. The gubernaculum shortens as descent takes place and finally becomes a vestige in the adult.

Prenatal descent of the testis into the scrotum also occurs in mammals, such as the monkey, horse, bull, pig, sheep, and goat. Descent occurs postnatally in the opossum, whereas it takes place in the pubertal period in rats, mice, rabbits, and guinea pigs. The monkey occupies a somewhat intermediate position. The testes descend before birth but then migrate back into the abdominal cavity until puberty when descent occurs for the second time

TABLE 5.1

*Comparison of average volume of structures in the testis of man and the rat*

All figures are percentages of total testicular volume. (From E. C. Roosen-Runge, *Fertil. & Steril.*, 7, 251, 1956.)

	Man	Rat
Interstitial tissue	22.0	8.0
Leydig cells	3.1	1.7
Basement membrane	9.1	2.4
Total interstitial space	34.2	12.1
Spermatogonia	7.8	1.7
Spermatocytes	14.4	14.7
Spermatids and spermatozoa	9.1	41.1
Abnormal germ cells	0.7	0.1
Residual bodies		1.2
Total germ cells	32.0	58.8
Sertoli cells	17.4	8.4
Lumen	10.6	19.5
Space	5.8	1.1

(Wells, 1944). In seasonal breeders like the ground squirrel, the testes alternate between scrotum and abdomen with the breeding and nonbreeding seasons.

The mechanism of testicular descent is not entirely understood. The gubernaculum seems to act as a guide for the descending testis, but it is not essential for descent. Excision of the gubernaculum does not prevent descent (Wells, 1943a, b). Growth of the testis is not a determining factor in its downward migration. Martins (1943) showed that substitute testes in the form of paraffin pellets can be made to descend in castrated rats by the administration of testosterone. Therefore, it appears that descent is determined by androgens affecting the testis and accessory structures. The questions as to what androgens are responsible for testicular descent, where they are formed, and how they are controlled remain unanswered. Because Leydig cells appear in the fetal testis of man during the fourth month and because Ferner and Runge

24. Right testis after another month, at 3 years and 1 day. Tubular diameter is 120 to 150  $\mu$ . Tubules are tightly packed and it is difficult to find Leydig cells. Cellular debris has been cleared from most tubules, and a new generation of spermatids with orderly arrangement is present.

25. Right testis 5 months later, at 3 years, 5 months, 1 day. Tubular diameter is 150  $\mu$ . Leydig cells are extremely rare. There are many presperm cells and a few mature sperm cells free in the lumen.

26 to 28. Adult testis, age 11 years, 6 months, 20 days. 26. Seminiferous tubule lumen lined by young spermatids. 27. Tubule lined by spermatids with spermlike heads. 28. Tubule containing mature sperm cells about ready to be shed. (From G. van Wageningen and M. I. Simpson, *Anat. Rec.*, 118, 231, 1954.)

(1956) have shown that these Leydig cells give strong histochemical reactions suggestive of the presence of steroidal materials, it is presumed that the human fetal testis produces androgens responsible for its descent. Were this true, it would appear reasonable that human chorionic gonadotrophin produced throughout the pregnancy could be responsible for the formation and secretion of androgenic substances by the fetal testis. Such an action would provide a function for human chorionic gonadotrophin during the last two trimesters of pregnancy. However, Wells (1944) held androgens from adrenal sources responsible for testicular descent.

The precise control of testicular descent is not known. Gonadotrophins effective on the Leydig cells induce rapid descent. Androgens hasten descent and estrogens inhibit it (Mussio Fournier, Estefan, Grosso and Albrieux, 1947). However, Finkel (1945) concluded that descent may be a genetic phenomenon in the opossum, which seems to be different from rodents in many aspects of testicular physiology. Because hormonal secretion is not detected in the opossum until the 100th day and because descent occurs earlier, it was doubted that androgens are responsible for descent.

The effects of cryptorchism on the histologic appearance of the human testis have been the subject of many studies. However, few new observations have been made since the excellent description by Cooper (1929) of the normal and retained testis in man. Cooper studied abdominal and serotal testes at various ages from birth to senility and concluded: (1) the farther the prepubertal testis descends, the more similar it is to its normal serotal mate; (2) sperm cells are rare in retained testes but occasionally may be found in testes held at the external ring; (3) the younger the child, the more normal is the retained testis; (4) the Leydig cells are not affected adversely by retention, nor are they more numerous, as earlier observers had thought. As a result of these conclusions, surgical treatment of retained testes in the first two years of life was advised.

Rea (1939) concluded erroneously that the undescended testis is normal until puberty but stated correctly that it rapidly de-

generates after puberty. That the retained testis may not be normal before puberty and is almost always abnormal after puberty was confirmed by Nelson (1953), and by Robinson and Engle (1954). Before the age of 5 years, the serotal testis and the cryptorchid testis are indistinguishable histologically; after this time, the cryptorchid testis is always retarded in growth and differentiation. Puberty is accompanied by growth of both the serotal and the retained testis, but the retained testis does not keep pace with its serotal mate. Nelson (1951) pointed out that fewer spermatogonia are present in the retained testis than in the serotal mate and that this difference becomes proportionally greater after puberty. The testis retained for a long time becomes fibrotic. The germinal epithelium (excepting the Sertoli cells) is destroyed but the Leydig cells are said to be normal. However, Sohval (1954) found that the number of Sertoli cells in the pubertal retained testis is less than that in the normal serotal testis. In older men, the Sertoli cells may be obliterated, in which case the tubules eventually become hyalinized. This is not an invariable sequence in testes retained for long periods. Sohval stated that a man, aged 42, produced sperm from a retained testis.

The comments just presented are based on the supposition that failure of descent occurs in normal testes because of adhesions or abnormalities of the canal, or because of failure of the normal stimulus for descent. However, lack of descent also may result because the testis is intrinsically defective (Nelson, 1953). Three boys were described whose undescended testes did not contain germ cells; however, the descended testes also did not have germ cells, so the relationship between germinal aplasia and nondescent is not clear. Another type of abnormality was described by Sohval (1954) and referred to as "tubular dysgenesis." These tubules were characterized by the absence of Sertoli cells and spermatogonia. Only undifferentiated cells were present. Furthermore, these tubules did not become fibrotic after puberty. Dysgenetic tubules were observed in about half of the cases of cryptorchism.

Little doubt exists, therefore, that the fer-

tility potential of cryptorchid human testis, regardless of the cause, is seriously damaged. Sterility is not an inevitable consequence of bilateral cryptorchism in man as indicated by the report of sperm in the ejaculate of bilaterally cryptorchid men (Sohval, 1954). The work of Gross and Jewett (1956) also indicates that cryptorchism does not always produce irreversible damage because some patients do become fertile when orchidopexy is carried out at puberty.

The studies of Engberg (1949) and Raaboch and Záhof (1956) indicate that the function of the Leydig cells of cryptorchid testes also may be impaired. The former found that bilaterally cryptorchid men excreted reduced amounts of urinary androgen and estrogen and had a lessened concentration of acid phosphatase (a secondary sex characteristic) in the semen. The latter two authors, contrary to previous reports, noted a high incidence of regressive Leydig cells. Also, severe androgenic insufficiency occurs in bilateral cryptorchid men in middle and old age. The affect of cryptorchism on hormonal function is best ascertained in experimental animals and will be considered shortly.

Spontaneous cryptorchism is found in many animals. Schultz (1938) found that 5 per cent of the wild gibbons shot during the Asiatic Primate Expedition of 1937 were cryptorchid. Many veterinary reports show cryptorchism in various farm animals and pets. Cryptorchism also results from a deficiency of biotin in the laboratory rat (Manning, 1950). None of these reports deals with functional aspects of retention.

Experimental cryptorchism maintained for 28 days in the rat is followed by recovery of spermatogenesis in 40 to 100 days after restoration of the testes to the scrotum. With a proportionally longer sojourn in the abdomen, fewer and fewer of the tubules recover until finally tubular damage is irreparable. Androgenic function is gradually lost. Castration cells appear in the pituitary in 75 days, the seminal vesicles are reduced in size after 240 days, and the prostate becomes atrophic in 400 days. This sequence parallels the requirement for androgen; the seminal vesicles need more androgen (2.5 times) than does the prostate for maintenance, and the prevention of eas-

tration changes in the anterior pituitary requires twice as much androgen as does maintenance of the seminal vesicles (Nelson, 1937). These results were confirmed by Moore (1942), who added that the effects of cryptorchism on androgen production are dependent on the age at which it is induced. Old rats are less affected than young animals.

In the guinea pig, old experiments showed that tubular degeneration occurs rapidly but that secretion of androgen continues for more than a year. Using the condition of the accessory sex organs and sex behavior as end points for the activity of male hormone, Antliff and Young (1957) found no evidence of diminished production of androgen in animals made cryptorchid two days after birth.

In the boar, bull, and stallion secondary sex characteristics can be maintained by bilateral retained testes or by the testis made unilaterally cryptorchid after removal of the scrotal mate (Moore, 1944). Schlotthauer and Bollman (1942) removed one scrotal testis from an adult dog and placed the other in the abdomen; the prostate was maintained for two years. Hanes and Hooker (1937) found that cryptorchid testes in swine contained only half the normal amount of androgen. Kimeldorf (1948) reported that cryptorchism in rabbits results in a decrease of some 40 per cent in the total urinary 17-ketosteroids, a change similar to that after castration. He suggested that altered metabolism of testicular hormone caused by high temperatures may be responsible for this decrease. In general, then, the cryptorchid testis is capable of producing androgen but, depending on species, probably in amounts less than normal. The longer the state of cryptorchism exists, the more deficient is the capacity to secrete androgens.

#### IV. Breeding Patterns

The breeding pattern of adult male mammals may be divided into two major types (Moore, 1937). The first type is that of the seasonal breeder, including such animals as the ground squirrel, weasel, stoat, ferret, mole, hedgehog, and shrew (Asdell, 1946). In these animals, there is a short period of time, the duration of which varies in differ-

ent species, in which breeding is at its height, sperm cells are formed only during this period. The accessory sex structures are under intense androgenic stimulation. After the breeding season, regression occurs. For the remainder of the year spermatogenesis does not take place and the state of the accessory system resembles that of a castrated animal (Fig. 5.4).

The second type is the continuous

breeder. Rat, mouse, guinea pig, rabbit (under laboratory conditions), and man are well known examples. In this type, the testes and accessory sex structures maintain a constant state of activity, and breeding can occur at any time of the year.

The ram is an intermediate type of breeder, in which spermatogenesis is arrested in the nonbreeding season with a concomitant decrease in number of Leydig

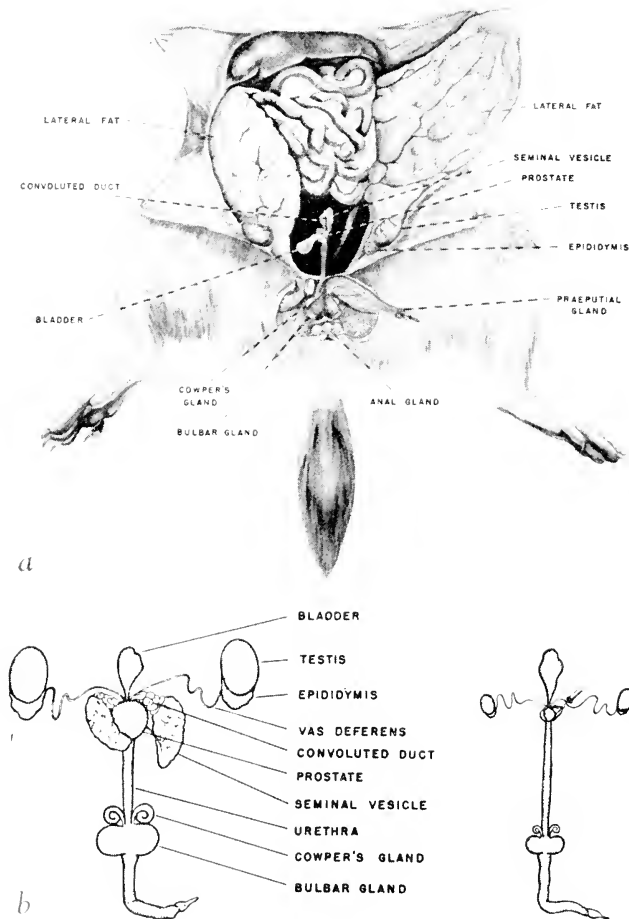

FIG. 5.1. Reproductive tract of a seasonal breeder, the prairie dog, *Cynomys*. *a*. Anatomy of male reproductive tract and its abdominal relationships during period of sexual activity. *b*. Diagrammatic representation of the sexually active and the involuted reproductive tracts (dorsal view). (From A. Anthony, *J. Morphol.*, **93**, 331, 1953.)



cells. Abnormal forms of sperm cells appear in the semen, reflecting the degeneration of the germinal epithelium at this time. The volume of the semen decreases, and libido is depressed. Thus, the ram may be regarded as an annual breeder, but the regression in the nonbreeding season is not complete (Maqsood, 1951a). Even the laboratory rat shows some evidence of a seasonal rhythm (Gunn and Gould, 1958). The capacity of the dorsolateral prostate to concentrate injected  $Zn^{65}$  is greater in February-March and June-July than at other seasons of the year.

Various species of squirrels have been favorite subjects for the investigation of certain features of seasonal breeders (Mossman, Hoffman and Kirkpatrick, 1955; Kirkpatrick, 1955). The testes of the infantile fox squirrel contain small, round, lumenless cords with a single row of spermatogonia, Sertoli cells, and a few spermatocytes. The Leydig cells are undifferentiated. The prepubertal fox squirrel has larger tubules with lumina. The testes at this time have increased about five times in weight, and the tubules are twice their former diameter. Spermatids are present.

The mature fox squirrel has free sperm cells in rather wide lumina, and mature, large Leydig cells. In the nonbreeding season, the spermatids and spermatozoa degenerate, leaving only spermatogonia, Sertoli cells, and a few spermatocytes. The tubular wall becomes contracted and thickens, causing the shape of the tubule to be irregular. The Leydig cells atrophy. In December and January, when the breeding season starts, the process of sexual maturation is repeated. This process recurs annually; however, with each year, the tubular wall becomes more irregular in shape demonstrating that periods of maturation and degeneration have taken place previously.

### V. Architecture of the Testis

The testis of most mammals is divided into lobules by means of septa, and the entire testis is enveloped by the tunica albuginea, which keeps it under pressure.

The testis of the rat, however, has no septa; instead, the organ is constructed in a fan-shaped manner from a series of spiral canal arches, which arise from the rete testis (Fig. 5.5). The tubule is a U-shaped structure, open at two ends to the

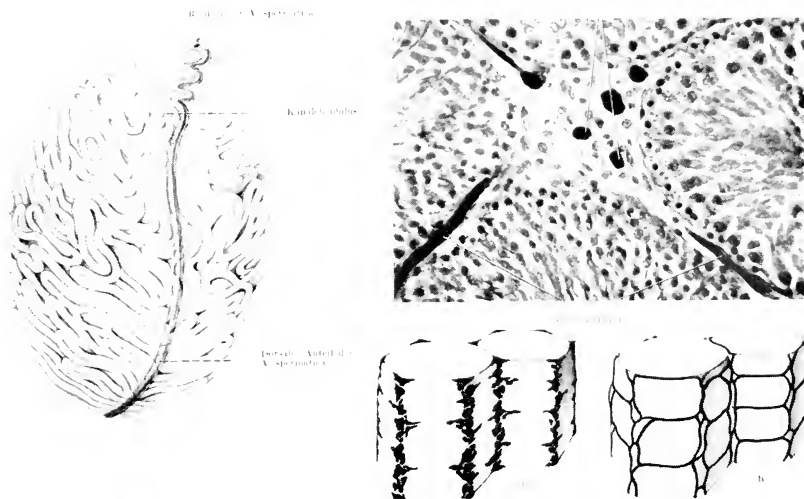

FIG. 5.5. Architecture of rat testis, showing relationship of tubules to spermatic artery, and arrangement of the Leydig cell aggregates and capillaries. (From I. Müller, *Zschr. Zellforsch. mikroskop. Anat.*, **45**, 522, 1957.)

rete and running such a constant zigzag course within the testis that a palisade is formed. An average tubule is 30 cm. long. The tubules do not end blindly as a rule. They rarely fork or bifurcate and they never communicate with one another (Müller, 1957; Clermont, 1958).

The suitability of architecture of the tubule for the process of spermatogenesis is obvious because it provides an epithelium with a large surface area. The arrangement of the tubules in arcs and palisades allows long tubules to be packed neatly in a small, ovoidal organ. The lumen of the tubule constitutes a pathway for the transport of sperm to the outside. Because sperm cells are transported passively, some mobile medium is needed. The obvious medium is fluid which can be transferred along the length of the tubule. It is not known where and how such fluid enters the tubule and how it moves through the lumen as it transports sperm to the ductuli efferentes.

If fluid moves constantly along the length of the tubule to carry sperm, it must be reabsorbed from the excretory duct system. The ductuli efferentes, derived from the mesonephros, may play a role analogous to that of a nephron in reabsorbing large quantities of fluid from the seminiferous tubules (Ladman and Young, 1958). The cytologic organization of ciliated and non-ciliated cells in the ductuli efferentes and rete testis of the guinea pig seems compatible with the presumption that these cells absorb fluid from the lumen and excrete it by way of the ductular system. Physiologic evidence of the transport of fluid within the excretory duct system will be given in Section VIII.

The architecture of the interstitium appears to be well adapted for the internal secretory function of the Leydig cells. Wedges of connective tissue are present in the interstices bounded by three tubules. The wedges contain Leydig cells, blood vessels, and connective tissue. Branches of the testicular artery feed the capillary network in the connective tissue wedges. The wedge capillaries are in close relationship to the Leydig cells. The topography of the capillary system of the rat testis is such that blood, after contact with the interstitial cells, flows by the generative portion

of the testis before entering the general circulation through the great veins at the hilum. This architecture apparently makes it feasible for hormones of the Leydig cells to exert local action on the tubule.

## VI. The Circulatory System of the Testis

The testicular artery of mammals convolutes before reaching the testis. It is surrounded by the pampiniform plexus which is thermoregulatory, serving to preheat or to precool the blood. The convolutions of the testicular artery constitute a distinctive feature of mammals (Fig. 5.6). Lower vertebrates have segmental arteries, the testes do not descend, and the arteries do not lengthen or convolute. Marsupials differ in that the artery forms a rete marabile from which a short artery enters directly into the testis. The testicular artery in the dog forms 25 to 30 loops before entering the tunica albuginea. In the goat, the artery convolutes many times but finally branches into 3 or 4 convolutions that enter the testis from all sides. The testicular artery in the mouse has half-loops; except for man, it shows the fewest convolutions of all the mammalian testicular arteries thus far investigated by arteriography. The situation in the monkey is similar to that in the dog, whereas the artery in the cat and the guinea pig has between 5 and 10 loops.

The testicular artery of man is unique in two respects. It is the longest and thinnest artery in all the viscera, and it is also the straightest testicular artery in the 50 mammals thus far investigated. The testicular artery of man after giving off branches to the cord and epididymis generally runs on the posterior border of the testis. It bifurcates, each branch penetrating the tunica over its lateral and medial aspects (Harrison and Barelay, 1948). The testicular artery in man has a direct anastomosis with the vasal and cremasteric arteries (Harrison, 1948a, b; 1949a, b; 1952; 1953a, b).

The gradient in temperature between the peritoneal and scrotal cavities varies widely among different species. A large gradient occurs in the goat, rabbit, rat, mouse, and ram; a small gradient is present in the monkey, dog, guinea pig, and man. The tem-

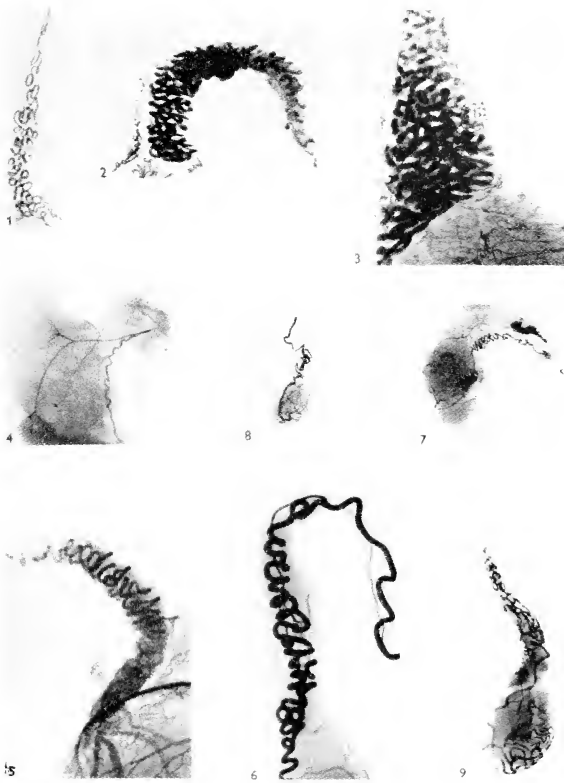

Fig. 5.6. Vascular patterns of the testis of a few mammals. Roentgenograms of testicular artery injected with opaque medium from (1) dog, (2) goat, (3) ram, (4) mouse, (5) rat, (6) rabbit, (7) guinea pig, (8) cat, and (9) monkey. (From R. G. Harrison and J. S. Weiner, *J. Exper. Biol.*, **26**, 304, 1949.)

perature gradient depends on many factors, such as the convolutions of the artery, the length of the artery, the size of the testis, the relationship between veins and arteries, and the activity of the dartos muscle (Harrison and Weiner, 1949).

Inasmuch as temperature affects the testis directly, and also indirectly by way of the circulatory system, it is necessary to deal separately with the direct effects of temperature on the testis, the effects of environmental temperature, and the effects of circulatory occlusion. It is generally agreed that heat applied locally is injurious to the testis. Moore's experiments in which the testes were wrapped in insulating material

already have been mentioned. In the guinea pig, sex activity and fertility are depressed for 44 to 72 days after exposure to heat (Young, 1927). Similar effects may be obtained (Williams and Cunningham, 1940) by heating rat testes with infrared lamps or by heating dog testes with microwaves from a radar source (Williams and Carpenter, 1957). In men, a single bout of fever (MacLeod and Hotchkiss, 1941) that increased the body temperature to 40.5°C, caused a depression in the sperm count. After return of the sperm count to normal, another episode of fever induced another depression. The production of androgen is not affected by exposure to high environ-

mental temperature (Stein, Bader, Eliot and Bass, 1949). The local application of heat does not markedly suppress the production of androgens, judging from the older work with rats and guinea pigs. To the contrary, some evidence exists that secretion of androgens may be enhanced. After scrotal insulation, bulls were more ready to serve and excreted more "androgenic" steroid than normal. The amount of fructose in semen (an indicator of androgen) increased after scrotal insulation in the ram (Glover, 1956). Increased temperature originating locally may affect spermatogenesis in man. Davidson (1954) studied semen in cases of oligospermia before and after removal of varicoceles. Removal of the varicocele was followed by an increased number of sperm cells and a greater incidence of fertility. Defective fertility presumably was caused by interference with normal heat transfer because of the varicocele.

Local application of cold to the testis or scrotum also results in testicular degeneration (Harris and Harrison, 1955); however, testicular tissue can be frozen and stored and still retain transplantability and subsequently produce hormones and sperm (Parkes, 1954; Parkes and Smith, 1954; Deanesly, 1954).

The effects of temperature when the entire animal is subjected to thermal changes depend on numerous compensatory alterations in testicular circulation. The compensatory mechanisms differ in both quality and degree, depending on the nature of the experimental conditions. The testicular temperature of rodents placed in a hot room does not increase to a higher level than that of the general body temperature. This is true also for the ram. Within fairly wide limits of environmental temperature (10 to 40°C.), the intratesticular temperature of the bull is constant. However, the temperature of the scrotal surface increases slightly with increases in air temperature, but remains below body temperature (Riemerschmid and Quinlan, 1941). The homeostatic mechanisms for maintaining a constant, optimal testicular temperature are several. With increasing scrotal temperature, the scrotum extends and the testes lie lower. This increases heat exchange, despite the absence in certain species (mouse, rat, dog,

cat, and rabbit) of scrotal sweat glands (Harrison and Harris, 1956). Optimal testicular temperature is also maintained by means of heat exchange between vessels of the pampiniform plexus. Exact data on the transfer of heat are not available, because determinations of the blood flow have not been done.

There remains for consideration the effect on the testis of severe alterations in circulation. The histologic changes produced in the rat testis by temporary or permanent occlusion of the testicular artery were studied in great detail (Oettlé and Harrison, 1952). Acute temporary ischemia (10 to 20 minutes in duration) produced only hyperchromasia of the spermatogonia. Normality was restored within 2 weeks. Ischemia of increasing duration produced correspondingly increased testicular damage. Hyperchromatic changes in the spermatogonia, loosening and exfoliation of the germinal epithelium, and desquamation of the mesothelium of the tunica occurred. The testis shrank, the interstitium became edematous, and the Leydig cells swollen. A layer of ragged and vacuolated Sertoli cells, a few spermatogonia, and an occasional primary spermatocyte may be the only surviving elements. When the damage was extreme, the tubule became markedly atrophic, the lumen disappeared, and the Sertoli cells became embedded in a collagenous matrix.

Permanent occlusion of the testicular artery in the rat can be accomplished by removing a segment of the artery within the abdominal cavity proximal to its anastomosis with the vasal artery (Fig. 5.7), which results in incomplete ischemia. After 1 hour of such occlusion, hyperchromasia of the spermatogonia occurs, with exfoliation of the spermatids. After 6 hours, the spermatocytes are exfoliated. One day later the testis enlarges considerably owing to edema. Multinucleated cells appear and many show pyknosis. The cytoplasm of the Sertoli cells disintegrates. After 3 days, all tubules are abnormal; within 1 week, they are necrotic. The damage is restricted at first to the central portion, but within a week practically all tubules except some near the epididymal pole have been killed. Two weeks later, vacuolation occurs in the Leydig cells, with

an accumulation of yellow pigment. By the end of a month, the interstitium becomes invaded by fibroblasts. The tubules, although not yet shrunken, show a thickened basement membrane. The necrotic contents conglomerate into a mass. After 7 months, pronounced interstitial fibrosis is present, extending from the periphery toward the center. Plasma cells are seen. Some of the Sertoli cells survive. The tubular debris is removed. Thus, it seems that the Leydig cells are most resistant to arterial occlusion. The Sertoli cells are the next most resistant, followed by the resting spermatogonia. The active differentiating cells are most susceptible to arterial occlusion.

A different type of lesion is produced by ligation of the superior epididymal artery. Focal necrosis of the initial segment of the caput occurs (Macmillan, 1956; Harrison and Macmillan, 1954). This disrupts the pathway between the vasa efferentia and the ductus epididymidis. The vasa distal to the ligature become choked with sperm within 3 days. The testes enlarge and then atrophy. In this manner, permanent atrophy of the testes occurs, with azoospermia due to obstruction.

## VII. The Nervous System and the Testis

It is difficult to see nerve endings in the parenchyma of the testis. Van Campenhout (1947, 1949a, b) described masses of paraganglionic cells in the midportion of the genital ridge of the testis during development. The fibers of these cells are intimately associated with the interstitial cells. The testes of 22-day-old pigs contain numerous neuro-interstitial connections between nerve fibers and groups of Leydig cells in the hilar zone or near the tunica.

The origin of testicular nerve fibers is not entirely clear. The general belief is that the testis receives fibers from the lumbar sympathetic chain. These nerve fibers innervate only the blood vessels in the rat and cat. Varying reports have been made of the nervous connections in man. Apart from vasomotor and sensory nerves, few fibers enter the human testis. These follow the course of the arteries to the septula and make contact with the Leydig cells. Three types of contact are made, namely (1) peri-

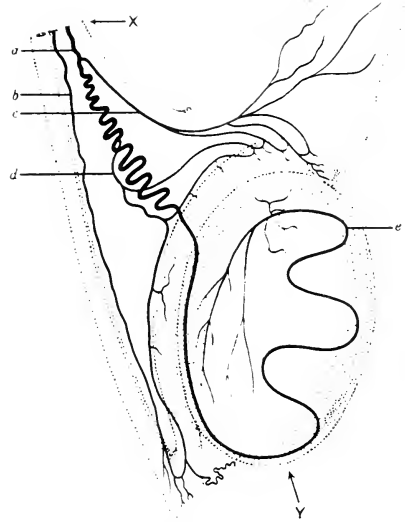

FIG. 57. Diagram of arterial supply of rat testis. The testicular artery (*a*), as it nears the testis, becomes tortuous just after giving off a branch (*c*) to the head of the epididymis that also supplies the fatty body (upper right). On reaching the testis, the testicular artery goes to the deep surface of the tunica albuginea. After coursing around the inferior pole, the artery winds up the anterior border of the testis, entering the parenchyma at *c* to break up into its terminal branches. The vasal artery (*b*) passes along the vas to reach the tail of the epididymis, where it anastomoses with the descending branch of the artery (*d*) supplying the body and tail. In the experiments, the testicular artery was permanently interrupted at point X (in the abdomen) or temporarily occluded at point Y. In the former case, the testis still would have some blood supply via the vasal artery; the branch of the testicular artery to the tail, and the terminal part of the testicular artery. However, the testicular artery is an end-artery at point Y. (From A. G. Oetlić and R. G. Harrison, *J. Path. & Bact.*, **64**, 273, 1952.)

neural, in which the Leydig cells lie alongside the nerve, (2) intraneural, in which groups of Leydig cells may be found within the perineurium, and (3) interdigitational, in which the course of the nerve breaks a cluster of Leydig cells into small groups (Okkels and Sand, 1940-1941). It is not certain that nerve fibers actually penetrate Leydig cells (Peters, 1957; Gray, 1947). Peters noted that nerve fibrils also

run to the walls of the tubules and enter the membrana propria to reach the Sertoli cells.

Experimental studies on the significance of the sympathetic nervous system with regard to testicular function have been only sporadically performed in lower animals. Coujard (1952, 1954) found that the sympathetic ganglia along the vas deferens are most important to testicular development in the guinea pig. If these ganglia are injured, hypoplasia and aspermatogenesis of the testis follow. Unilateral removal of the prostates vesiculodeferential ganglion causes ipsilateral testicular immaturity. Defects of spermatogenesis also are noted when distant lesions in the sympathetic trunk are produced. Coujard concluded that the sympathetic system is an obligatory intermediate between gonadotrophic hormones and the testis. Somewhat similar studies have been reported on the cat (King and Langworthy, 1940). If 7.5 cm. of the sacral and lumbar ganglionic chain are removed unilaterally, cessation of spermatogenesis occurs on the affected side within 2 or more weeks. The Leydig cells remain normal. Bilateral extirpation of strips of the ganglionic chain leads to reduction in spermatogenesis. In addition Weidenmann (1952) reported a diminution in volume of the Leydig cells after lumbar sympathectomy in cats. Destruction of the spinal cord by ultrasound in mice at levels from the eighth to the tenth thoracic segment had no effect on testicular weight, morphology, or spermatogenesis (Josimovich, 1958).

Lumbar sympathectomy in man has yielded variable results. Bandmann (1950) found atrophy of the testis and loss of potentia after unilateral lumbar sympathectomy; sperm examinations before and after operation disclosed deterioration in all of his cases. However, Alnor (1951) could not observe any effects in 14 patients after unilateral lumbar sympathectomy, and Kment (1951) found a temporary increase in potency in men after procaine block of the trunk. The effect of lumbar sympathectomy in man clearly needs more decisive study.

The poor sexual status of human paraplegics has led many authors to conclude that the nervous system controls testicular function in man. Apart from the muscular

disability of male paraplegics, such symptoms and signs as gynecomastia, loss of potency, atrophy of the testes, creatinuria, proteinuria, a decreased basal metabolic rate, loss of sex hair, and decreased excretion of 17-ketosteroids suggest testicular insufficiency (Cooper and Hoen, 1949, 1952; Cooper, Rynearson, Bailey and MacCarty, 1950; Cooper, Rynearson, MacCarty and Power, 1950). The extent to which these changes occur in paraplegics is debatable, and certainly not all changes are always present in any one patient. A study by Talbot (1955) of 400 paraplegic and quadriplegic patients showed that two-thirds were capable of achieving erection, and that one-third of these had successful intercourse. One-twentieth were fertile. It is obvious, then, that potency and fertility are not invariably lost. The histologic appearance of the testis in paraplegics has been determined by both biopsy and necropsy. In contrast to the variability in symptoms, the histologic appearance of the testis is more uniform. Atrophy of the tubule occurs, often with disappearance of all germinal epithelium except the Sertoli cells. The tubular wall is thickened. Leydig cells are present but may be found in clumps, giving the appearance of hyperplasia (Keye, 1956). Perusal of most of the illustrations showing atrophic testes in paraplegic men (Stemmermann, Weiss, Auerbach and Friedman, 1950; Klein, Fontaine, Stoll, Dany, and Frank, 1952; Bors, Engle, Rosenquist and Holliger, 1950) indicates that all stages of degeneration may be encountered. Some testes resemble those in adult seminiferous tubular failure, and others, especially those showing severe atrophy, resemble cryptorchid testes. It is most difficult to determine from a testis containing only Sertoli cells and clumped Leydig cells what the nature of the pathologic process was, because all types of atrophy end in the same general histologic picture regardless of cause.

Mental disease and mental stress are said to affect the testis. Jänkälä and Näätänen (1955) found that severely disturbed rats, presumably under "mental strain," showed marked atrophy of the testis within 6 weeks. The severity of this atrophy is evident from the finding that only Sertoli cells remained. Caged dogs, apparently under mental strain,

have transient testicular atrophy. Hormonal secretion is not impaired (Huggins, Masina, Eichelberger and Wharton, 1939). Testicular atrophy has been noted in schizoid patients (Hemphill, 1944; Hemphill, Reiss and Taylor, 1944) and was thought to be caused by this severe mental illness. However, the histopathologic appearance of the testis in schizophrenia is not specific (Blair, Sniffen, Cranswick, Jaffe and Kline, 1952; Tournay, Nelson and Gottlieb, 1953) and it may not be stated that mental illness has any direct or specific action on the human testis.

### VIII. The Excretory Duct System

The old concept that vasectomy is followed by hypersecretion of male hormone and rejuvenation has been disproved completely. Recent studies have been concerned with the effects of occlusion of the excretory ducts on the tubular apparatus. Although some reports have indicated that the testes of rats and rabbits decrease to one-half normal size after vasoligation, the majority opinion is that no change in testicular weight occurs (see Young, 1933, for review). Poynter (1939) did not observe any changes in the structure of the rat testis one year after vasoligation. Atrophy of the testes was obtained only when vasectomy was performed serotally; under these circumstances, it resulted from adhesions subsequent to operation. No change was observed in the seminal vesicles, indicating no alteration in secretion of androgen. Also, no changes were evident in the Leydig cells.

Ligation of the ductuli efferentes, however, does produce pressure atrophy of the germinal epithelium (Young, 1933; Mason and Shaver, 1952). The testis becomes swollen and tense owing to distention of the ductuli with sperm on the testicular side of the ligation. The rete is also dilated. Peritubular fibrosis occurs, especially in tubules at the periphery of the testis. Degeneration of the germinal epithelium then ensues. Ten weeks after ligation, only Sertoli cells are left in the tubules. The Leydig cells remain unscathed (Harrison, 1953a).

The difference in effect of ligation of the excretory path distal or proximal to the epididymis is attributable to the function of the excretory duct system of reabsorbing

fluid needed to carry sperm. Obstructive necrosis of the testis does not occur after ligation of the ductus deferens, because reabsorption of fluid takes place. This would also explain the absence of testicular atrophy in clinical states of inflammatory obstruction along the excretory pathway caused by gonorrhoea or of obstruction caused by congenital absence of the ductus deferens.

### IX. The Seminiferous Epithelium

Clarification of the spermatogenic cycle in the germinal epithelium is probably the most important development in knowledge of the testis since the second edition of this book. The difficulties in expressing spermatogenesis in quantitative terms were great. Clear identification of each type of cell was not possible. Certain basic information on the transformation of one type of cell into another, on the renewal of certain cells, and on degenerative phenomena was lacking. Despite these difficulties, the time of a complete spermatogenic cycle in the rat was estimated by several investigators using different methods. These methods were (1) time of recovery after irradiation of the testis, (2) morphologic studies of the changes in cellular population with reference to a static cell such as the Sertoli cell, and (3) turnover time of organically bound radiophosphorus in the germinal epithelium (Howard and Pele, 1950). The introduction of the periodic acid and fuchsin sulfurous acid (PAS) stain for glycol groups such as exist in glycogen, mucoprotein, and mucopolysaccharides solved the difficulties enumerated above.

Cytologic studies have shown that the cells of the seminiferous epithelium are organized in similar associations. The development of any one generation of a certain type of cell is correlated with other generations present in the same part of the tubule. The changes in a certain zone of the germinal epithelium between two successive appearances of the same cellular association constitute a cycle. Different investigators do not use the same number of phases, the same classification of cell types, or the same points of reference. Depending somewhat on the cytologic detail and somewhat on the

point of reference, the cycle can be divided into 6, 8, 12, or more phases.

Roosen-Runge (1951-1955), Roosen-Runge and Barlow (1953), and Roosen-Runge and Giesel (1950) used eight phases to characterize a seminiferous cycle in the rat. In phase 1, no sperm cells are present in the tubule; at the end of phase 8, the sperm cells forming over the intervening phases have disappeared from the lumen. Two types of spermatogonia are recognized; type A is a large cell with a large nucleus and little chromatin, and type B is a smaller cell with a smaller nucleus and masses of chromatin arranged peripherally. Type A spermatogonia divide simultaneously in phase 1 and again at phases 4, 6, and 7, leading to successive doublings. Type B spermatogonia form from type A in phase 6. In phase 8, a total of 98 per cent of all the spermatogonia are type B, leaving a 2 per cent quota of type A to start the cycle over again. When the spermatozoa are floated off the tubular wall, type B spermatogonia rapidly change into prespermatocytes. The prespermatocytes grow rapidly and become spermatocytes. Spermatid formation occurs in the first four phases. Spermatozoa are present from the end of phase 5 through phase 8.

Interestingly, the Sertoli cells show a cyclic variation in volume, being largest at phases 7 and 8 and smallest at phase 1. Retraction and expansion of the Sertoli cells, with cycles of spermatogenic activity, was noted by Rolshoven (1945, 1947, 1951). When the cells retract, part of the cytoplasm is lost, leaving a pars basalis. In expanding, this part of the Sertoli cell forms a fine lattice. The Sertoli cells resorb regressive spermatozoa and probably also the residual bodies during the spermatogenic cycle.

Because PAS-positive material can be traced back to the Golgi apparatus of young spermatids (Leblond, 1950), Leblond and Clermont (1952a, b) have been able to divide spermiogenesis in the rat into 19 stages. In the first 8 of these, the germinal epithelium has old spermatids, which are released when the new crop reaches stage 8. Hence, the new crop of spermatids is alone until they reach stage 15, when another generation of spermatids appear. Therefore, stage

1 and stage 15 spermatids appear together, and the succession of cells associated with this appearance marks one cycle. These authors have divided their 19 stages of spermiogenesis into four phases (Fig. 5.8).

The first phase is the Golgi phase, which includes 3 of the stages. In stage 1, the idiosome is in the Golgi zone and two centrioles are near the chromatoid body. The fine filament from one centriole eventually becomes the tail of the sperm. In stage 2, one to four granules appear in the idiosome. In stage 3, the fusion of pro-acrosomic granules into one large one is accomplished.

The second phase is the cap phase, which consists of 4 stages. In stage 4, the acrosome granule flattens on the nucleus. In stage 5, a membrane arising from the granule spreads over the nucleus. In stage 6, a cap is formed over the nucleus. The idiosome separates from the acrosome granule, and the two centrioles move closer to the nucleus. In stage 7, the cap reaches maximal size. The proximal centriole adheres to the nucleus, and the flagellum remains attached to the distal centriole. The chromatoid body is loose in the cytoplasm.

The third phase is the acrosome phase, which includes 7 stages. The caudal tube is present, and the head caps are oriented toward the tubular wall. In stage 8, the granule and cap move toward the basement membrane, and the cytoplasm shifts to the opposite pole of the nucleus. The chromatoid body surrounds the flagellum near its insertion to the distal centriole. In stage 9, the acrosome granule elongates. In stage 10, the head cap moves toward the caudal end of the nucleus, and the apical end is pointed. In stage 11, the nucleus and head cap elongate. In stage 12, the nucleus is at its maximal size. In stage 13, the nucleus is thinner, and the distal centriole divides into a dot and ring. In stage 14, the head cap is loose over the nucleus, the cytoplasm condenses, and the spermatid begins to look like a mature spermatozoon.

The fourth phase is the maturation phase, which consists of 5 stages. In stage 15, the head cap has a finlike membrane; the ring centriole separates from the centriole and forms the middle piece. In stage 16, elongation of the finlike membrane occurs. In stage 17, the acrosome and head cap move for-





FIG. 5. Spermiation in the rat. 1 to 3, *Golgi phase*. The idiosome produces two proacrosomic granules, which fuse into the single acrosomic granule. 4 to 7, *cap phase*. The acrosomic granule produces the head cap, which enlarges to cover a third of the nucleus. 8 to 14, *acrosomic phase*. The nucleus and head cap elongate, whereas the acrosomic granule transforms into the acrosome. 15 to 19, *maturation phase*. Near the end of this phase, the reactivity of the head cap and acrosome decreases considerably, and the spermatozoon is released into the lumen (19). (From C. P. Leblond and Y. Clermont, *Ann. New York Acad. Sc.*, **55**, 548, 1952.)

ward. In stage 18, the perforatorium appears. In stage 19, the staining capacity of the sperm is sharply reduced.

The behavior of the remaining cells of the germinal epithelium now can be correlated. Five peaks of mitosis occur in the spermatogonia. The first three peaks give rise to type A spermatogonia, the fourth peak to type B spermatogonia, and the fifth to spermatocytes. Spermatocytes, formed in stage 6, undergo the long meiotic division and become spermatids at stage 1 of the third cycle.

This quantitative method has been applied to three areas which are of importance

to the experimental or clinical endocrinologist: renewal of stem cells, postnatal degeneration of germ cells, and the effects of hypophysectomy on the germinal epithelium.

The renewal of spermatogonia always has been puzzling. It was postulated that they were renewed from the Sertoli cells, from unequal mitosis of a spermatogonium into a spermatocyte and another spermatogonium or from type A cells which did not differentiate into type B cells. Clermont and Leblond (1953) proposed a new theory for the renewal of stem cells. Three types of spermatogonia are present in the rat testis

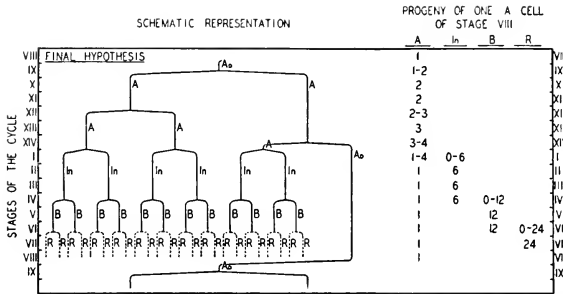

FIG. 5.9. Diagrammatic representation of the most probable pattern for the development of spermatogonia (or "stem cell renewal theory"). The Roman numerals on either side of the diagram indicate the stages of the cycle. A, type A spermatogonia;  $A_0$ , dormant type A spermatogonia; In, intermediate type of spermatogonia; B, type B spermatogonia; R, resting spermatocyte. In this hypothesis, the two daughter cells of the stage IX mitosis do not divide simultaneously. One of the granddaughter cells becomes a new dormant type A cell ( $A_0$ ), ensuring the renewal of the spermatogonial population at the subsequent cycle, whereas the three other daughter type A cells divide again to produce intermediate type cells, which in turn produce type B cells, which in turn produce spermatocytes. (From Y. Clermont and C. P. Leblond, *Am. J. Anat.*, **93**, 475, 1953.)

mouse (Fig. 5.9). Type A spermatogonia give rise to either intermediate spermatogonia or to dormant type A spermatogonia. The intermediate type of spermatogonia gives rise to the type B forms, which produce spermatocytes. The dormant type A spermatogonia are so designated because they do not divide for 8 stages. At the 9th stage, the dormant type A spermatogonium forms 4 large type A spermatogonia. In the next cycle, one of these 4 type A spermatogonia becomes another dormant type A spermatogonium; the others form 6 of the intermediate types of spermatogonia and eventually 24 spermatocytes. The cytologic details and the alterations in numbers of the three types of spermatogonia are illustrated in Figure 5.10. Full information can only be obtained by consulting the original papers.

Considerable degeneration of the primary germ cells occurs during development of the testis in the mouse and the rat (Allen and Altland, 1952). Degeneration usually ceases on the ninth day of age in the rat. Over the next 4 days, however, considerable multiplication occurs, but from day 14 to day 48 degenerating cells also may be seen in many tubules. Six different types of degeneration are evident—loss of cells in layers (exfoliation or shedding), necrosis, loss of individ-

ual cells, pyknosis, degeneration of leptotene forms, and abnormal mitosis in stem cells and spermatocytes.

The degeneration of the germ cells, or gonocytes, soon after birth had given the impression that the spermatogonia arise from the small supporting cells that also form the Sertoli cells in the adult. Gonocytes have a large, light, spherical nucleus, fine chromatin, and a sharp nuclear membrane. The supporting cells have smaller nuclei and coarse chromatin. The fourth day of life in the rat the supporting cells increase in number and form a palisaded layer along the basement membrane. The gonocytes swell and begin to degenerate; however, some of them look like type A spermatogonia. By day 6, most of the spermatogonia are type A but a few intermediate spermatogonia and type B forms appear. By days 9 to 12, gonocytes are no longer present. Primary spermatocytes appear for the first time in resting leptotene stages. By days 15 to 18, two generations of germ cells are present. By days 23 to 26, the spermatocytes are in meiotic prophase and some spermatids are being formed. By days 33 to 50, the Sertoli cells have matured. Because the supporting cells do not divide after day 15, type B spermatogonia can-

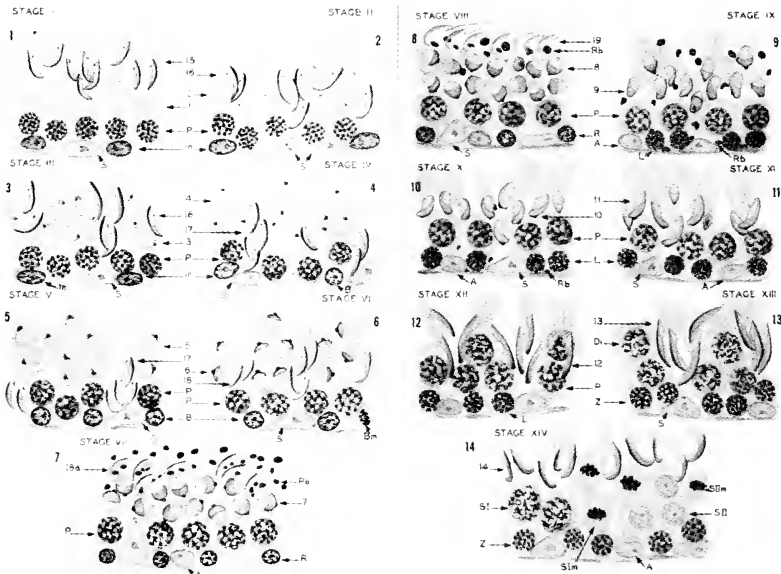

Fig. 5.10. Diagrammatic drawings of stages I to XIV of the cycle of the seminiferous epithelium. Drawings made from PAS-hematoxylin stained preparations. Numbers 1 to 19 refer to spermatids at different steps of spermiogenesis. A, type A spermatogonia; B, type B spermatogonia; Bm, mitosis of spermatogonia; R, resting spermatocytes; L, leptotene stage; Z, zygotene stage; P, pachytene, Di, diplotene and diakinesis; Sl, primary spermatocytes; SIm, primary spermatocyte metaphase; SII, secondary spermatocytes; SIIIm, secondary spermatocyte metaphase; S, Sertoli element; Rb, residual body. (From R. Daoust and Y. Clermont, *Am. J. Anat.*, **96**, 255, 1955.)

not arise from supporting cells (Clermont and Percy, 1957).

It was known that, after hypophysectomy, spermatids disappear but spermatogonia, Sertoli cells, and primary spermatocytes remain for long periods and spermatogonial mitosis continues. Clermont and Morgentaler (1955) noted spermatids being phagocytosed by the Sertoli cells within 3 days after hypophysectomy. Young spermatids at stages 1 through 7 are present, but at 10 days after hypophysectomy, no developing spermatid has reached stage 9. A few pachytene spermatocytes are degenerating, but primary and secondary spermatocytes are present during the first week after the operation. By the tenth day, the Sertoli cells shrink but do not disintegrate. Spermatogonial types A and B remain intact. Maximal regression after hypophysectomy is reached within 29 days.

The basement membrane is thick and there are two rows of type A, intermediate, and type B spermatogonia, a few primary and secondary spermatocytes, spermatids at stages 1 through 7, and Sertoli cells. Type B cells form spermatocytes, but the spermatocytes degenerate before and during meiosis, and only 4 per cent of them survive to produce spermatids. The spermatids develop to stage 7 and then disintegrate. Therefore, spermatogenesis up to stage 7 of spermiogenesis can occur in the absence of the pituitary gland but at a greatly reduced rate. As was surmised from early observations on the maintenance of spermatogenesis by androgen, the premeiotic phase of spermatogenesis apparently can take place without gonadotrophins; meiosis suffers severely from gonadotrophic deprivation; and the postmeiotic phase is controlled by androgen. The observation that testes-



FIG. 5.11. Spermiogenesis of the mouse as seen with PAS-hematoxylin staining of Zenker-formol fixed testis. Drawings are arranged in a spiral to demonstrate stages which overlap in a cycle of the seminiferous epithelium. Orientation of spermatids in relationship to the basement membrane also is shown. 1 to 3 is the *Golgi phase*, 4 to 7 the *cap phase*, 8 to 12 the *acrosomic phase*, and 13 to 16 the *maturation phase*. (From E. F. Oakberg, *Am. J. Anat.*, **99**, 391, 1956.)

terone can maintain spermatogenesis if it is administered within a month after hypophysectomy but cannot if treatment is delayed more than a month may not be so puzzling if it is assumed that androgen protects in some way the serious depletion of spermatocytes at meiosis.

The plan of spermiogenesis in many species is essentially similar to that in the rat and mouse. Clermont (1954) found that the hamster shows the same successive stages of spermatogenesis except that five cycles may be represented simultaneously. In the mouse, Oakberg (1956a, b) described 16 stages, the first 12 of which constitute a cycle (Fig. 5.11 and Table 5.2). Four cycles constitute complete spermatogenesis and require 34.5 days. Generally, the same plan of spermiogenesis holds for the guinea pig, cat, bull, dog, ram, monkey (Fig. 5.12), and

man (Leblond and Clermont, 1952b; Clermont and Leblond, 1955), although many differences in cytologic detail exist and have been documented (Zlotnik, 1943; Gresson, 1950; Gresson and Zlotnik, 1945, 1948; Burgos and Fawcett, 1955; Watson, 1952; Challice, 1953).

Application of quantitative studies to human spermatogenesis has, to date, been disappointing. Spermatogenesis does not proceed along a wave, nor are the various stages sharply delimited, as they are in the rat. Further, the testis of the human also differs from that of the rat in that the relative proportion of differentiated germ cells to spermatogonia is less. No helpful findings in cases of human infertility have been obtained by quantitative analysis of the germinal epithelium (Roosen-Runge and

TABLE 5.2

Characteristic cell associations at each stage of the cycle of the seminiferous epithelium  
(From E. F. Oakberg, *Am. J. Anat.*, **99**, 391, 1956.)

Stage of Cycle	I	II	III	IV	V	VI	VII	VIII	IX	X	XI	XII
Spermatogonia												
Type A	A	A	A	A	A	A	A	A	A	A	A	A
Intermediate		In	In	In								
Type B				B	B	B						
Spermatocytes I												
First layer								R		L		Z
									L			
						R	R	L		Z	Z	P
												Dia
Second layer	P	P	P	P	P	P	P	P	P	P	Dip	M-I
Spermatocytes II												S
												M-II
Spermatids (see Fig. 1)												
First layer	1	2	3	4	5	6	7	8	9	10	11	12
Second layer	13	14	14	15	15	15	16	16				
A	= Spermatogonia type A			R			= Resting					
In	= Intermediate type spermatogonia			L			= Leptotene					
B	= Spermatogonia type B			Z			= Zygotene			Primary		
M-I	= First meiotic division			P			= Pachytene			spermatocytes		
S	= Secondary spermatocyte			Dip			= Diplotene					
M-II	= Second meiotic division			Dia			= Diakinesis					

Barlow, 1953; Roosen-Runge, Marberger and Nelson, 1957).

**X. The Interstitial Tissue**

Although miscellaneous general information is available on the interstitial tissue of many animals, including the gorilla, the short-tailed manis, and the vampire bat (Popoff, 1947), detailed knowledge comes from common laboratory animals, such as the rat, mouse, guinea pig, rabbit, and cat. With the exception of man, however, the life history of the interstitial tissue of the testis is probably known best for the bull (Hooker, 1944, 1948).

In the 1-month-old bull, when widely separated, lumenless tubules are present, the intertubular spaces contain only mesenchymal cells. The number of Leydig cells gradually increases up to 2 years of age; after this time, the Leydig cells become vacuolated and increase in both number and size (Fig. 5.13). From 5 to 15 years of age, loss of vacuolation and decrease in size occur. After 15 years of age, degeneration ensues.

Metamorphosis of the Leydig cell begins with nuclear changes. The nucleus acquires 1 to 3 nucleoli, increases by 25 per cent in volume, and becomes spherical. Hypertrophy and hyperplasia of the cell occur. The cell still retains its stellate appearance, but becomes polygonal in shape after granules appear in the cytoplasm. After 2 years of age, vacuolation occurs and, with age, the vacuoles become larger. At 5 years of age, vacuolation is present in all Leydig cells. Regression of the Leydig cells begins at 7 years of age; it is manifested by a decrease in vacuolation and mitotic activity (Hooker, 1944, 1948), and ends in cellular disintegration (Fig. 5.14).

In addition to regression, Leydig cells may also dedifferentiate. This occurs in the rabbit. In autografts of testis to the ear, mature Leydig cells show fusion of granules, shrinkage of cytoplasm, loss of nuclear transparency, and finally cannot be distinguished as a Leydig cell (Williams, 1950).

The life history of the Leydig cell in man and monkey is in general similar

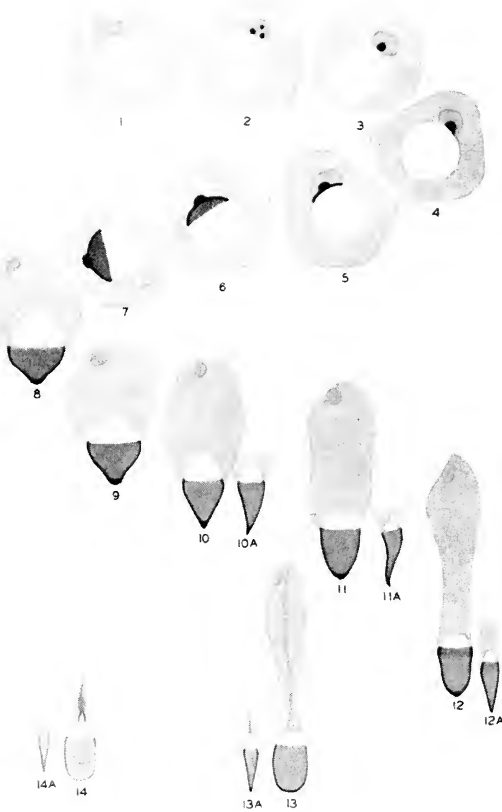

FIG. 5.12. Spermogenesis in the monkey. 1 to 3 is the *Golgi phase*, 4 to 7 the *cap phase*, 8 to 12 the *acrosoma phase*, and 13 to 14 the *maturation phase*. (From Y. Clermont and C. P. Leblond, *Am. J. Anat.*, **96**, 229, 1955.)

that in the bull. In the human, Leydig cells are large polyhedral cells containing a large vesicular nucleus, which is not found in other cells of the interstitial tissue. The cells contain pigment, vacuoles, crystalloids, and granules. The granules vary in density, number, and arrangement within the cytoplasm. These granules contain lipides (Nelson and Heller, 1945) and, like those in common laboratory animals (Pollock, 1942), give reactions of steroids. Various types of Leydig cells can be distinguished on the basis of the size and nature of the granules and vacuoles. The medium-sized

granular cells are believed to be vigorous producers of androgen (Sniffen, 1952; Tillingier, Birke, Franksson and Plantin, 1955). It is difficult to determine the absolute number of Leydig cells. However, rough counts made in testes of men (necropsy material) indicate that the number declines with age (Sargent and McDonald, 1948). In general, the excretion of 17-ketosteroids and the development and condition of secondary sex characteristics parallel histologic and cytologic evidence of secretory activity by the Leydig cells (Fig. 5.15).

It is generally held that the Leydig cell

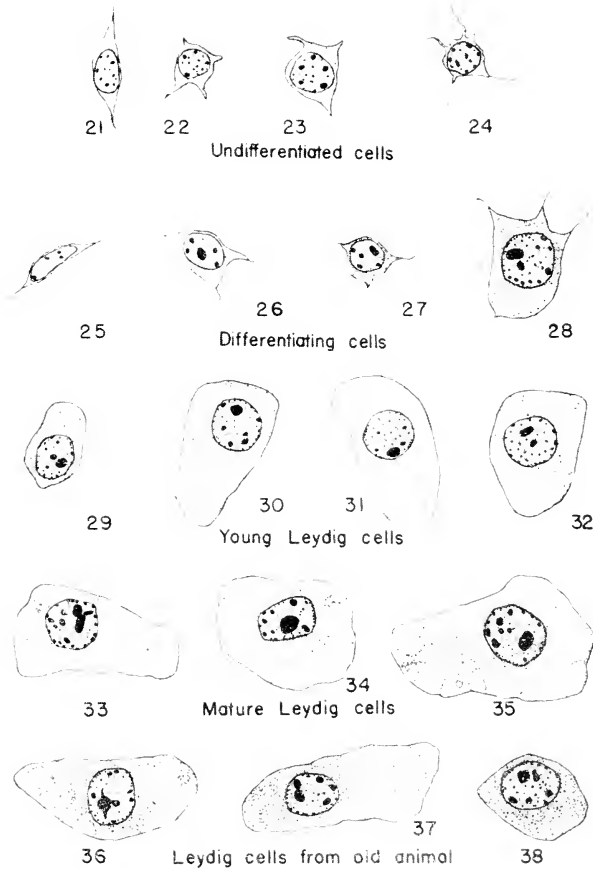

FIG. 5.13. Life history of Leydig cells of the bull testis. 21 to 24, calf 1 month old. 25, calf 1½ months old; note threadlike processes extending from angulation of mesenchymal cell. 25 to 27, cells of interstitium; 25 is a fibroblast, and 26 and 27 are pre-Leydig cells. 28, bull 4 months old. 29 and 30, bull 2 years old, with young Leydig cells. 31 and 32, bull 28 months old; note vacuoles. 33 to 35, mature Leydig cells in a 5-year-old bull. 36 to 38, bull 15 years old. (From C. W. Hooker, *Am. J. Anat.*, 74, 1, 1944.)

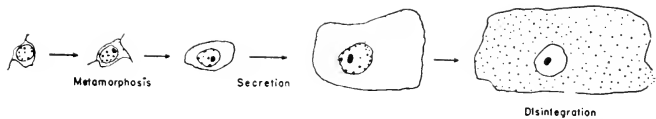

FIG. 5.14. Life history of the Leydig cell of the bull. (From C. W. Hooker, *Recent Progr. Hormone Res.*, 3, 173, 1948.)

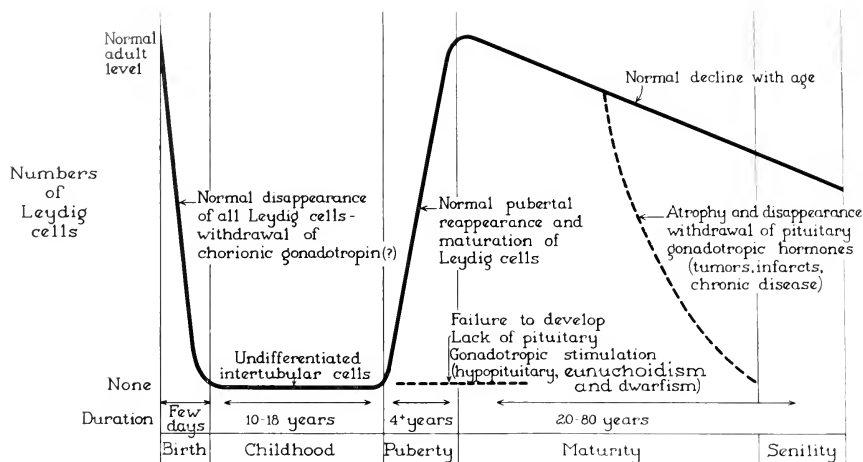

FIG. 5.15. Schematic summary of the life history of the human Leydig cell. (From A. Albert, L. O. Underdahl, L. F. Greene, and N. Lorenz. Proc. Staff Meet., Mayo Clin., **29**, 368, 1953; **30**, 31, 1955.)

is the source of androgen. Gonadotrophin evokes secretion of androgen from the testis only if the Leydig cells are stimulated. Tumors of Leydig cells produce large amounts of androgen. Testes impaired by heat or x-rays still produce androgen even though the germinal epithelium may be destroyed. The parallelism between the number of Leydig cells, their morphology, histologic appearance, and histochemical properties (Wislocki, 1949), on the one hand, and androgenic secretion as measured chemically or as determined by the behavior of the secondary sex characteristics, on the other hand, supports the conclusion that the Leydig cell produces male hormone (Figs. 5.16 and 5.17).

### XI. Hormones of the Testis

The mammalian testis produces androgens and estrogens. Because the chemistry of the hormones is discussed in Villee's chapter, only a brief account will be given here. Testosterone was first obtained from bull testes and later from horse testes (Tagmann, Prelog and Ruzicka, 1946). However, difficulties attended the isolation of testosterone from the testes of pigs. Although not obtained in crystalline form, testosterone was identified by a characteristic in-

frared absorption spectrum in extracts of hog testes (Prelog, Tagmann, Lieberman and Ruzicka, 1947). Other steroids are present in hog testes (Ruzicka and Prelog, 1943; Prelog and his associates, 1947). C21-ketosteroids, such as allopregnane-3-( $\beta$ )-ol-20-one, allopregnane-3-( $\alpha$ )-ol-20-one, and 5-pregnane-3-( $\beta$ )-ol-20-one, have been identified. Haines, Johnson, Goodwin and Kuizenga (1948) isolated pregnenolone from hog testes as well as several other unidentified steroids, some of which had estrogenic activity. Ketosteroids have been found in human sperm (Dirschel and Breuer, 1955).

The testes of deer, bulls, stallions, and humans contain estrogens. The amount present in deer testes is three times that in bulls (Cunningham, May and Gordon, 1942). Estradiol (0.21 mg. per kg.) and estrone (0.36 mg. per kg.) were isolated from 28 kg. of horse testes by Beall (1940). Estradiol also has been isolated from human testes obtained shortly after death (Goldzieher and Roberts, 1952).

Testicular tissue is able to convert acetate into cholesterol (Srere, Chaikoff, Treiman and Burstein, 1950) and also to testosterone in the hog, rat, and human (Brady, 1951). Human chorionic gonadotrophin



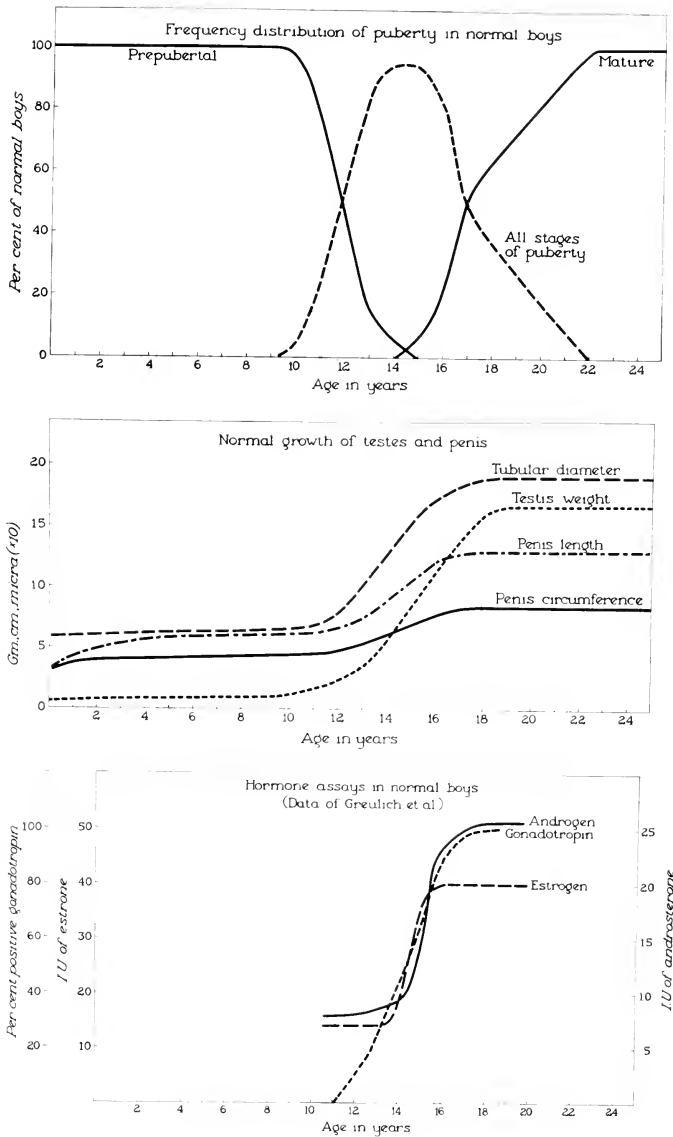

FIG. 5.16. Frequency of puberty, measurements of testis and penis, and excretion of hormones during puberty in man. (From A. Albert, L. O. Underdahl, L. F. Greene, and N. Lorenz, Proc. Staff Meet., Mayo Clin., **28**, 409, 1953.)

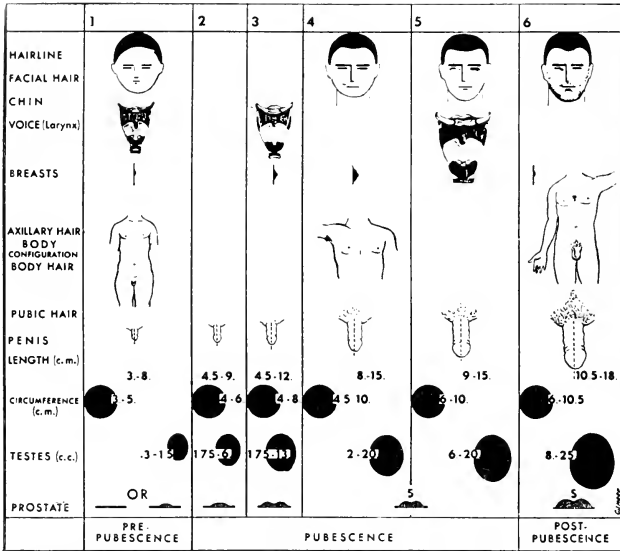

FIG. 5.17. Stages of sexual development and maturation. (From W. A. Schonfeld, *Am. J. Dis. Child.*, **65**, 535, 1943.)

(HCG) increases the yield of testosterone from testicular slices incubated with acetate. Estradiol-17- $\beta$  also has been found in the products obtained by incubating tissue slices with acetate. Human testicular tumors incubated with labeled acetate form labeled testosterone, androstenedione, progesterone, estradiol, and estrone (Wotiz, Davis and Lemon, 1955). Mevalonic acid, a precursor of cholesterol, yields estradiol when incubated with homogenates of human testis (Rabinowitz and Ragland, 1958). The biogenesis of male hormone as worked out in the stallion, rat, and human (Savard, Dorfman and Poutasse, 1952; Savard, Besch, Restivo and Goldzieher, 1958; Savard, Dorfman, Baggett and Engel, 1956) by means of radioisotopic methods shows a common pathway from 17 $\alpha$ -hydroxyprogesterone  $\rightarrow$  progesterone  $\rightarrow$  4-androstene-3,17-dione  $\rightarrow$  testosterone. Testosterone has been identified in the spermatic vein blood of dogs (West, Hollander, Kritchewsky and Dobriner, 1952). Also identified were  $\Delta^4$ -androstenedione-3-17 and 7-keto-cholesterone.

In addition to confirming the presence of

several biologically active steroids in the testis, the studies made in the last two decades have clarified the biosynthesis of male hormone. The peripheral metabolism of testosterone and its biologic actions in the organism are described in chapters by Vilce and by Price and Williams-Ashman, respectively.

In addition to these well-known steroid hormones, the presence of a water-soluble hormone in the testis has been postulated on biologic evidence. Vidgoff, Hill, Vehrs and Kubin (1939) and Vidgoff and Vehrs (1941) induced atrophy of the testis and accessory sex organs in the rat by the administration of aqueous extracts of bull testes. Because the atrophy was similar to that occurring after hypophysectomy, it was claimed that a water-soluble principle in the testis was capable of inhibiting the gonadotrophic function of the pituitary. This principle was called "inhibin." The theory was then constructed that the testis secretes two hormones, namely a water-soluble hormone responsible for the integrity of the germinal epithelium by regulating the secretion of pituitary gonadotrophin, and a fat-

soluble hormone (testosterone) responsible for maintaining the accessories. The observations of Vidgoff and his associates were disputed by Rubin (1941). The inhibin concept was supported by McCullagh and Hruby (1949) because testosterone did not inhibit the excretion of pituitary gonadotrophin and was not effective in correcting castration changes in the pituitary of cryptorchid rats at doses that were sufficient to stimulate the accessories. Inhibin was now identified with estrogen, and the source of estrogen was claimed to be the Sertoli cell. The new evidence for this modified concept will now be considered.

McCullagh and Schaffenburg (1952) stated that estrogen is much more effective than androgen in suppressing gonadotrophin and that estrogen is present in saline extracts of bull and human sperm. Estrogen is found in the testes, but localization of its production to the Sertoli cells is uncertain (Teilum, 1956), and is doubted by Morii (1956) and Ballerio (1954). The almost complete absence of Sertoli cells in Klinefelter's syndrome, in which values for urinary gonadotrophin are high, also is considered as evidence that estrogen is manufactured by the Sertoli cells. The high excretion of gonadotrophin in Klinefelter's syndrome can be interpreted, at least in part, by the concept of Heller, Paulsen, Mortimore, Jungck and Nelson (1952) that the amount of urinary gonadotrophin varies inversely with the state of the germinal epithelium. Utilization of gonadotrophins by the germinal epithelium could explain the levels of this hormone in various syndromes as satisfactorily as the lack of a hypothetic testicular inhibitory hormone. Furthermore, if the Sertoli cells secrete an inhibitory hormone, patients who have germinal aplasia (Sertoli cells only in the tubules) should have normal values for urinary gonadotrophin, whereas it is well known that this hormone is greatly increased in these patients. The proponents of the inhibin theory claim that aqueous extracts of testes prevent the castration changes but do not repair the accessories, whereas testosterone corrects the accessories but does not restore the normal histologic appearance of the pituitary. However, Nelson showed that cryptorchid testes produce less androgen

than normal and that the order in which the above structures are affected represents differences in the degree of their sensitivity to the amount of androgen produced. The efficacy of aqueous extracts on the cytologic appearance of the pituitary has not been confirmed. Thus, evidence deduced from cryptorchism that an inhibitory hormone is produced by the germinal epithelium is inadequate.

## II. Effects of the Pituitary on the Testis

Little information has been added in the past 20 years to the effects of acute hypophyseal deprivation on the mammalian testis. Smith (1938, 1939) had shown in the rat that spermatocytes as well as spermatogonia and Sertoli cells remain for a long time after hypophysectomy. However, in the monkey, and possibly in man, all cells of the germinal line except the spermatogonia and the Sertoli cells disappear. Even though hypophysectomy has been employed for several years as a palliative procedure in inoperable carcinoma of the prostate, no data have been obtained concerning the effects of hypophysectomy on the testis in otherwise normal man. In the dog, the testes decrease to about one-third their normal weight after surgical removal of the pituitary. Only a single row of spermatogonia remains (Fig. 5.18). The Leydig cells are reduced in size and contain abundant quantities of fat. The lack of complete involution of the Leydig cells in the dog as a result of hypophysectomy is somewhat unusual, because marked involution of these cells occurs in all other mammals thus far studied. With respect to the behavior of the germinal epithelium, the dog (Huggins and Russell, 1946) seems to be more like the monkey and man than like the rat and mouse. The total relative decrease in testicular weight of the dog is intermediate between that observed in the cat (50 per cent) and that in the rat, guinea pig, and rabbit (75 per cent). With respect to histologic features, the guinea pig and ferret are intermediate between the rat and the monkey, because occasional spermatocytes remain in addition to spermatogonia and Sertoli cells. In the mouse, the testicular weight decreases for 25 days after hypophysectomy. At

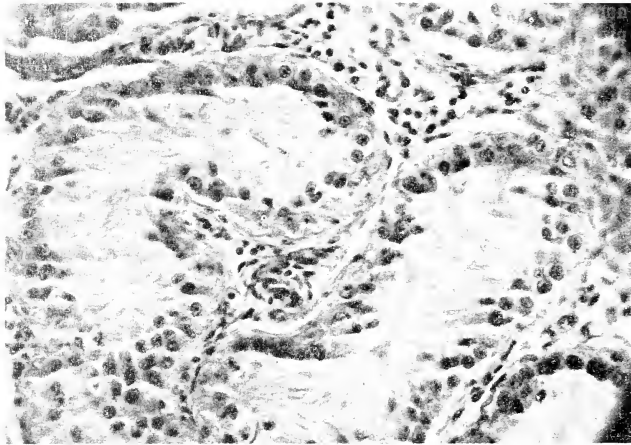

Fig. 5.18. Testis of dog 60 days after hypophysectomy. (From C. Huggins and P. S. Russell, *Endocrinology*, **39**, 1, 1946.)

(1952) showed that early differentiation of spermatids in the rat is affected first by hypophysectomy. Spermatids degenerate, tubular fluid is lost, and atrophy of the germinal epithelium finally takes place (Gothie and Moricard, 1939).

Some recent studies on compensatory hypertrophy of the remaining testis after unilateral orchiectomy have been made. Old investigations showed that compensatory hypertrophy occurs in boars, rabbits, and hedgehogs. Compensatory hypertrophy does not occur in mature guinea pigs or man (Calzolari, Pulito and Pasquinelli, 1950; Pasquinelli and Calzolari, 1951; Zide, 1939). In the prepubertal guinea pig and rat, however, the remaining testis shows accelerated development. The volume of the remaining testis increases in the adult rat after unilateral orchiectomy (Grant, 1956). Since the compensatory hypertrophy is suppressed by testosterone, it appears likely that the accelerated development of the remaining testis is mediated by gonadotrophins.

The effects of gonadotrophins on testicular structure and function have been studied in many species. Injection of anterior pituitary extract or implantation of fragments of the anterior pituitary into the testis of guinea pigs has resulted in pronounced stimulation and hypertrophy of the Leydig cells

(Pétrovitch, Weill and Deminatti, 1953; Petrovic, Deminatti and Weill, 1954; Petrovic, Weill and Deminatti, 1954; Mareseaux and Deminatti, 1955). In hypophysectomized mice, May (1955) found that testicular grafts of anterior pituitary tissue repair the atrophic tubules and the involuted Leydig cells.

The effects of individual gonadotrophins of both pituitary and placental origin have been reviewed by Greep (1937) and Fevold (1944), and in the chapter by Greep in the present volume. The established concept, as worked out in the rat, is that follicle-stimulating hormone (FSH) maintains and repairs the tubular apparatus but does not affect the function or structure of the Leydig cells. Luteinizing hormone (LH) maintains the functional activity of the Leydig cells but does not directly control tubular activity.

Urinary gonadotropin from menopausal women stimulated the tubules (Greep, 1937) and the Leydig cells (Bahn, Lorenz, Bennett and Albert, 1953a-d). Human chorionic gonadotrophin (HCG) has little or no effect on the tubules, but it induces pronounced stimulation of the Leydig cells. Pregnant mare serum (PMS) stimulates spermatogenic and endocrine activities of the testis. Both LH and HCG maintain spermatogenesis after hypophysectomy.

Neither FSH nor LH hastens the appearance of sperm in the testis of immature animals. No type of gonadotrophin has induced the appearance of sperm in the rat earlier than 35 days of age.

Because interest in the chemical fractionation of animal pituitary tissue waned after 1945, new studies on the effects of pituitary gonadotrophins on the testis have not been performed. Instead, HCG has received attention. The well known hyperemia induced in the ovary by HCG, which is used as a pregnancy test, has been reported to occur also in the testis by Hartman, Millman and Stavorski (1950). Hinglais and Hinglais (1951) have not confirmed this. HCG causes increased testicular weight in young rats (Rubinstein and Abarbanel, 1939). The effect of HCG on the rat testis has been summarized by Gaarenstroem (1941), who listed the following four main actions: (1) stimulation of the Leydig cells in both normal and hypophysectomized animals to produce androgen; (2) increase in growth of the testis in the normal immature animal; (3) maintenance of testicular tubules in hypophysectomized animals; (4) potentiation of the effects of pituitary gonadotrophins in either normal or hypophysectomized animals. All effects are interpreted as being caused by the increased liberation of androgen. This explanation probably also holds for the increased fibrosis in and around the tubular wall in hypophysectomized rats after administration of HCG, for the increase in the number of primary spermatocytes (Muschke, 1953; Tonutti, 1954), and for the slight increase in testicular weight (Diezfalusy, Holmgren and Westerman, 1950).

The effects of HCG in normal men are similar to those in animals (Maddock, Epstein and Nelson, 1952; Maddock and Nelson, 1952; Weller, 1954). The Leydig cells become hyperplastic and produce more estrogen and androgen. This is reflected first by an increase in urinary estrogen of some 5- to 20-fold and later by an increase in 17-ketosteroids of about 2-fold. The increased secretion of steroids by the Leydig cells is accompanied by an increase in the frequency of erections and occasionally by gynecomastia. The increased levels of estrogen and androgen induce tubular atrophy.

The tubular diameter becomes smaller, spermatogenesis ceases, and there is an increase in necrosis and sloughing of the germinal cells. The basement membranes become hyalinized, and peritubular fibrosis develops. In certain eunuchoidal persons (hypogonadotropic hypogonadism), use of HCG induces differentiation of the Leydig cells and hastens maturation of the Sertoli cells. Some spermatogenesis is obtained (Heller and Nelson, 1947, 1948; Maddock, Epstein and Nelson, 1952). If FSH also is administered to such eunuchoidal men, complete spermatogenesis occurs (Heller and Nelson, 1947).

PMS acts on the rat testis in a manner intermediate between that of HCG and FSH (Greep, 1937; Kemp, Pedersen-Bjergaard and Madsen, 1943). Tubular growth and hyperplasia of the Leydig cells result. Interstitial cell hyperplasia also occurs in mice (Bishop and Leatham, 1946, 1948), although the testicular weight does not increase after the use of PMS, as it does in rats. In the opossum, PMS does not induce secretion of androgen until the animals are 70 days of age (Moore and Morgan, 1943). PMS is able to maintain the monkey testis after hypophysectomy but only for 20 days, after which involution occurs. If given to a hypophysectomized monkey in which testicular atrophy already is present, PMS causes formation of spermatocytes, but it does not induce the formation of spermatids or sperm cells (Smith, 1942). In man, PMS causes an increase in testicular weight (Hemphill and Reiss, 1945).

Unfractionated extracts of pituitaries of sheep or horses induce both tubular maturation and androgenic formation (Sotiriadou, 1941). Preparations of FSH in mice produce slightly heavier testes but do not cause androgenic secretion (Moon and Li, 1952). Purified preparations of LH produce atrophy of the tubules and stimulation of the Leydig cells in infantile rats, and maintenance of germinal epithelium and Leydig cells in hypophysectomized rats (Zahler, 1950).

### XIII. Effects of Steroids on the Testis

Between 1930 and 1940, rapid advances were made in the understanding of pituitary and gonadal interrelationships, and the

cept of a servomechanism controlling pituitary-testis activities was well established. According to this concept, male hormone was considered to have its major effect on the testis by inhibiting the secretion of pituitary gonadotrophins. However, it was difficult to fit into this concept the report by Walsh, Cuyler and McCullagh (1934) that testosterone was capable of maintaining spermatogenesis in the rat after hypophysectomy. If testosterone were the medium by which spermatogenesis was maintained normally, the dualistic concept of gonadotrophic control of the testis would be in jeopardy. As can be imagined, this finding stimulated much research. By 1940 the fact that spermatogenesis is maintained in hypophysectomized rats, mice, and rabbits by testosterone was amply established (Cutuly and Cutuly, 1940).

#### A. ANDROGENS

The varied effects obtained by injecting male hormone into normal and hypophysectomized rats depend on the nature of the androgen, the dose, the length of the treatment period, and the age of the animals when injections are begun. Inasmuch as most of the experimental work has been done with the rat and rats of various ages and sizes were employed, it is obvious that the dose of hormone is an important factor. Doses of testosterone of 100  $\mu\text{g.}$  per day or less can be regarded as small doses, whereas doses of 1 mg. or more can be considered as large. These definitions pertain only to the doses employed in studying the action of androgen on the testis and do not necessarily have any relationship to the physiologic levels of testosterone produced by the rat testis, which is not known, or to the effects of testosterone on the accessory sex organs (Moore, 1939).

In general, testosterone has no action on the undifferentiated gonad of the mouse, rat, opossum, or guinea pig (Moore and Morgan, 1942). In the immature rat small doses of testosterone propionate depress the testicular weight (Zahler, 1947; Dischreit, 1939; Greene and Burill, 1940). However, if small doses are continued for long periods, incomplete suppression results. Because the testicular inhibition induced by small doses of testosterone apparently results from sup-

pression of gonadotrophins, it seems that greater quantities of gonadotrophins are formed as rats grow; hence, escape from suppression may occur (Biddulph, 1939). The work of Rubinstein and Kurland (1941) indicates that even small doses of testosterone, as already defined, may produce different effects in the rat. These investigators compared the effects of administration of 5 and 50  $\mu\text{g.}$  testosterone propionate per day in young animals. Young rats receiving the former dose showed increased testicular weight without, however, any hastening of maturation of sperm cells. The larger dose decreased testicular weight.

The effect of androgen on mature rats is also dependent on dose. Small doses cause atrophy of the mature testis because of suppression of gonadotrophins. Large doses have the same suppressing effect, but this is overridden by a direct stimulating effect of androgen on the testis, and atrophy does not occur. In both instances, the Leydig cells are atrophic (Shay, Gershon-Cohen, Pashkis and Fels, 1941). Large doses of testosterone have a direct action on the testis as indicated by the protective effect exerted on the experimentally induced cryptorchid testis (Hamilton and Leonard, 1938) and on the transplanted testis (Klein and Mayer, 1942).

The aftereffects of androgenic administration also depend on the age of the animal and the duration of therapy. Using fecundity, libido, potency, and the state of the reproductive tract as indices of testicular function, Wilson and Wilson (1943) examined rats 3 to 5 months after a 28-day period of injection of androgen. In rats age 1 to 28 days, androgen severely affected the reproductive system. Low libido, absence of fecundity, and atrophic accessories were noted 3 to 5 months after testosterone therapy was discontinued. However, the later this treatment was instituted in the life of the rat, the more normal was the reproductive system 3 to 5 months after administration of the hormone was stopped.

Nelson and Merckel (1937), in a series of extensive experiments, confirmed the earlier finding that various androgens maintain spermatogenesis in the rat after hypophysectomy. Furthermore, they showed that the Leydig cells are atrophic in the face of

active spermatogenesis in the androgen-treated, hypophysectomized rat. Comparing such steroids as testosterone, androstosterone, dehydroisoandrosterone, androstenedione, and various isomers of androstenediol, they concluded that the ability of androgens to maintain spermatogenesis is not related to their androgenicity. In fact, the weaker the androgen the better is the maintenance of spermatogenesis after hypophysectomy. This observation is important for it shows that maintenance of spermatogenesis is not due to the induction by androgen of a favorable serotal environment for the testis. In further studies, Nelson (1941) showed that spermatogenesis could be maintained for

178 days after hypophysectomy by testosterone propionate. No difference was observed between spermatogenesis under these conditions and that which occurs normally. Motile sperm were formed, and the animals could copulate with and impregnate females. The only difference was that the testes in the hypophysectomized animals treated with testosterone were only one-sixth normal size.

As is true of other effects of androgens on the testis, the time at which rats are hypophysectomized seems to be a critical factor in the ability of testosterone to maintain spermatogenesis. Leatham (1942, 1944) showed that treatment with testosterone in

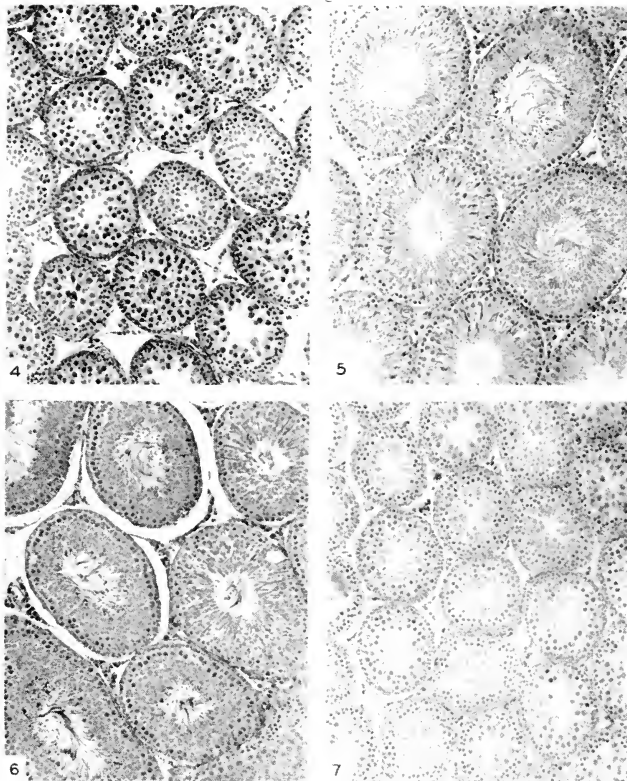

FIG. 5.19A. Effect of testosterone on the testis of the rat. 4, normal rat, 30 days of age. 5, normal rat, 60 days of age. 6, 30-day-old rat given 10  $\mu$ g. of testosterone propionate daily for 30 days (no inhibition of spermatogenesis). 7, 30-day-old rat given 100  $\mu$ g. of testosterone propionate daily for 30 days (suppression of spermatogenesis).

rats hypophysectomized at 27 days of age resulted in the production of spermatids, but spermatogenesis did not occur. However, if the animals were operated on at 33 days of age, testosterone induced the formation of sperm. Furthermore, if the atrophic testes of hypophysectomized rats were stimulated by a gonadotrophin (PMS), testosterone also maintained the spermatogenesis thus induced.

It is not known exactly how testosterone maintains spermatogenesis after hypophysectomy. It seems that the "maintenance type" of spermatogenesis is not the same as spermatogenesis resulting from gonadotrophin, because the seminiferous tubules of the androgenically maintained testes in hypophysectomized rats are small. The ef-

fect of androgen is not produced simply by the maintenance of sperm cells already present in the testis at the time of hypophysectomy because Nelson (1941) showed that spermatogenesis can be reinstated in the testis of a hypophysectomized rat in spite of delaying treatment with testosterone for 3 to 4 weeks after hypophysectomy. This interval of time exceeds the normal sojourn of sperm cells in the epididymis; thus the results in terms of siring young cannot be attributed to sperm cells already present in the accessory duct system at the time of hypophysectomy (Figs. 5.19, *A* and *B*, and 5.20).

The dose of testosterone propionate necessary for maintenance of spermatogenesis in the rat seems to be around 80  $\mu\text{g}$ . per day.

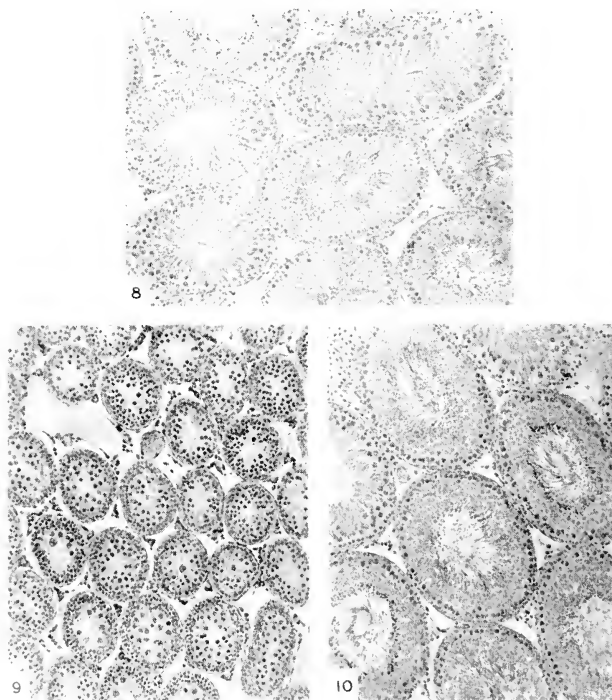

FIG. 5.19B. 8, 30-day-old rat given 1000  $\mu\text{g}$ . of testosterone propionate daily for 30 days (no suppression of spermatogenesis). 9, 30-day-old rat given 8.4  $\mu\text{g}$ . of estradiol daily for 30 days (pronounced inhibition of spermatogenesis). 10, 30-day-old rat given 8.4  $\mu\text{g}$ . of estradiol and 1000  $\mu\text{g}$ . of testosterone propionate for 30 days (no inhibition of spermatogenesis). (From D. J. Ludwig, *Endocrinology*, **46**, 453, 1950.)



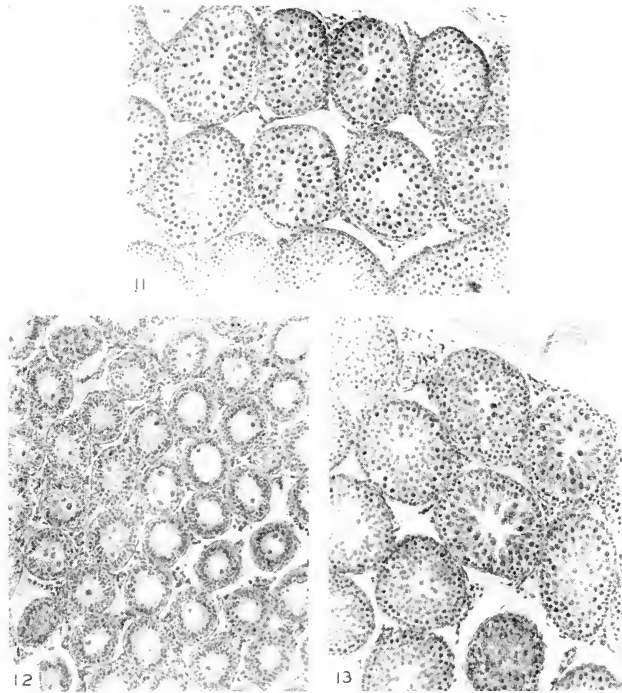

FIG. 5.20. Effect of testosterone on testis of hypophysectomized rat. 11, testis of normal rat, 30 days of age. 12, testis of 60-day-old rat hypophysectomized at 30 days of age. 13, testis of 60-day-old rat hypophysectomized at 30 days of age and given 1000  $\mu$ g. testosterone propionate daily for 30 days. (From D. J. Ludwig, *Endocrinology*, **46**, 453, 1950.)

However, larger doses generally have been used in experiments on the maintenance of spermatogenesis. These doses are far greater than those necessary to maintain the accessory sex organs of castrated animals. Tubules can be maintained by much smaller doses of testosterone. Dvoskin (1944) implanted pellets of testosterone intratesticularly; approximately one-tenth of the amount of testosterone needed by the parenteral route was effective by this route.

The concept that testosterone maintains spermatogenesis in hypophysectomized rats was challenged by Simpson, Li and Evans (1942, 1944) and by Simpson and Evans (1946a, b). These investigators found that gonadotrophins, including interstitial cell-stimulating hormone (ICSH), maintained spermatogenesis in hypophysectomized rats at doses far lower than those needed to

maintain the Leydig cells and the accessories. The testes remained in the scrotum, and motile sperm cells were produced. Inasmuch as testosterone propionate can maintain the tubules only at doses effective in maintaining the accessories, it was doubted that maintenance of spermatogenesis occurred by way of the direct tubular action of androgen. In addition to casting some doubt on the accepted mechanism of the spermatogenic action of androgen, this work raised doubt concerning the dualistic concept of gonadotrophic control of the testis. Maintenance of the testis by ICSH after hypophysectomy suggests that one gonadotrophic hormone may be sufficient to maintain testicular function in mammals. However, these findings may be interpreted conventionally; *i.e.*, that ICSH caused the Leydig cells, even though they were not

paired morphologically, to secrete androgen which, by virtue of its local action on the tubules, maintains spermatogenesis (Ludwig, 1950).

Testosterone maintains spermatogenesis in other species. In hypophysectomized ground squirrels, the testes are atrophic, aspermatic, and abdominal (Wells, 1942; 1943a). Hypophysectomized animals given testosterone propionate (0.5 mg. per day for 15 to 25 days) show growth of the testes, sperm formation, and testicular descent. Leydig cells remain atrophic. Because sperm formation ceases after hypophysectomy in the ground squirrel, as it does in the monkey, rat, guinea pig, mouse, cat, and ferret,

it is obvious that androgen initiated spermatogenesis.

Testosterone propionate maintains the spermatogenic activity of the testis of the hypophysectomized monkey for 20 to 50 days (van Wagenen and Simpson, 1954). A dose of about 20 mg. per day is required. When medication is discontinued, marked involution of the testis occurs within the ensuing 3 weeks. Testosterone is effective even after a lapse of 50 days between hypophysectomy and the institution of therapy. Spermatogenesis can be restored and formation of motile sperm cells induced. As in the rat, the testes maintained by androgen are smaller than normal. Pellets of testosterone implanted locally exert a strong local action. Thus, the essential findings in the rat are duplicated in the monkey (Fig. 5.21).

In man the effects of testosterone on the testis have been studied by Hotchkiss (1944a), and by Heller, Nelson, Hill, Henderson, Maddock, Jungck, Paulsen and Mortimore (1950). The main effects were disappearance of the Leydig cells, atrophy of the tubules, arrest of spermatogenesis, and pronounced hyalinization of the basement membrane (Fig. 5.22). Complete recovery of the testis occurred 17 months after cessation of therapy. In fact, the testes were histologically more normal than before treatment. The improvement in sperm production after preliminary depression of the testis by administration of testosterone has been used widely in the treatment of male infertility. Heekel, Rosso and Kestel (1951) and Heekel and McDonald (1952a, b) obtained an increase in spermatogenic activity, as determined by sperm counts and biopsy, after cessation of treatment. This increase was termed a "rebound phenomenon"; during it, increased fertility, as determined by an increased incidence of pregnancy among infertile couples, was reported. The improved quality and quantity of sperm following therapy with testosterone are transient. Furthermore, they occur in only a small proportion of men so treated (Getzoff, 1955; Heinke and Tonutti, 1956). The suppressive effect of androgen on the human testis results from inhibition of pituitary gonadotrophin as evidenced by measurement of the amount of urinary gonadotrophin before, during, and after use of

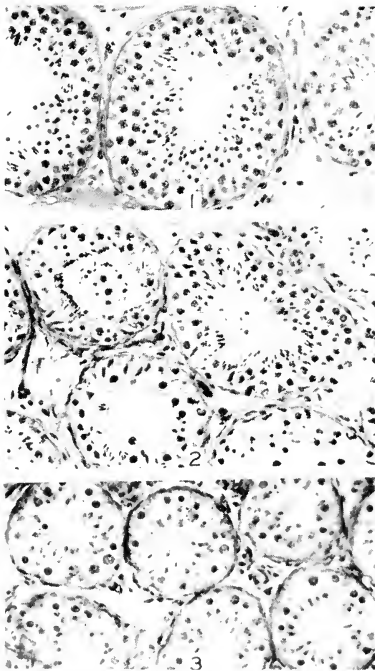

FIG. 5.21. Effect of androgen in a hypophysectomized monkey. 1, biopsy specimen from a normal 8-kg. rhesus monkey. 2, biopsy specimen from a hypophysectomized monkey after 56 days, during which 14 gm. of testosterone propionate was administered at a daily dose of 25 mg. 3, state of testis 20 days after use of testosterone was discontinued. Note atrophy of tubules. The Sertoli cells and spermatogonia remain. (From P. E. Smith, *Yale J. Biol. & Med.*, 17, 281, 1944.)

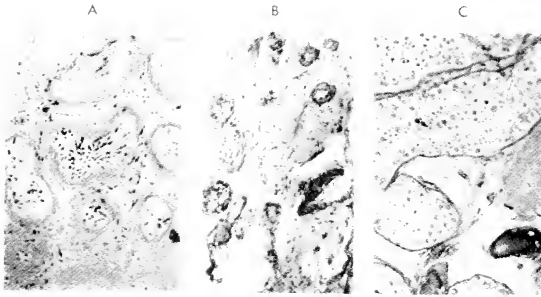

FIG. 5.22. Effect of testosterone on the testis of a man with infertility caused by adult tubular failure. Testicular biopsies, showing the pronounced degree of sclerosis and hyalinization that occurs when an initially very poor testis is subjected to the administration of 91 consecutive injections of testosterone propionate, 25 mg. each. *A*, before treatment; *B*, at end of 91 days of treatment; *C*, 17 months after cessation of treatment. Note, in *C*, the disappearance of hyalinization, the increase in size of the seminiferous tubules, and the appearance of fairly orderly spermatogenesis. Leydig cells, not shown here, were present 17 months after treatment was stopped. (From C. G. Heller, W. O. Nelson, I. B. Hill, E. Henderson, W. O. Maddock, E. C. Jungek, C. A. Paulsen and G. E. Mortimore, *Fertil. & Steril.*, **1**, 415, 1950.)

testosterone. The mechanism by which gonadotrophin is inhibited always has been assumed to be a direct effect of androgen on the pituitary. It is interesting in this regard that Paulsen (1952) showed that the use of testosterone, while reducing urinary gonadotrophin, increases the amount of urinary estrogen 20-fold. Estrogen is by far the most powerful suppressant of gonadotrophin secretion known; hence, it is possible that the atrophy of the testis observed during testosterone therapy in man may be caused by estrogen. No reports of maintenance of spermatogenesis in men with pituitary insufficiency or after hypophysectomy are available.

#### B. ESTROGENS

Various natural and synthetic estrogens have been given to rats, guinea pigs, hamsters, cats, bulls, boars, and man. In all forms, estrogen induces atrophy of the male gonad. The histologic appearance of the atrophic rat testis after estrogen therapy has been described by Dischreit (1940). In young rats, estradiol prevents testicular descent, produces atrophy, and inhibits spermatogenesis (Pallos, 1941; Gardner, 1949). Two weeks following atrophy induced by estradiol or stilbestrol, regeneration of the testis begins (Bourg, Van Meen-

sel and Gompel, 1952) and is complete within 6 weeks (Lynch, 1952). However, Snair, Jaffray, Grice and Pugsley (1954) noted that the accessory sex organs recover before spermatogenesis resumes. The same inhibiting effects have been obtained with methylbisdehydrodoisynolic acid (Tuchmann-Duplessis and Mercier-Parot, 1952) and hydroxypropiophenone (Lacassagne, Chamorro and Buu-Hoi, 1950). In general the effect of estrogen in the rat is to induce atrophy of the Leydig cells and germinal epithelium, so that only spermatocytes, spermatogonia, and Sertoli cells remain.

Uncertainty exists concerning the general effects of estrogen in guinea pigs. Lynch (1952) noted that the Leydig cells are normal in animals treated with estrogen, but Marescaux (1950) and Chomé (1956) noted that the Leydig cells are atrophic. Marescaux, in studying hypophysectomized guinea pigs, concluded that estrogen has a direct stimulating effect on the Leydig cell. Massive tubular damage occurs in the guinea pig after administration of estrogen. In the hamster, Bacon and Kirkman (1955) found that various estrogens induce testicular atrophy. In occasional animals, hyperplasia of interstitial and Sertoli cells occurs and is attributed to direct effects of estrogen. In general, atrophy of the germinal epithelium

is nearly complete; only a few spermatozoa remain in addition to the Sertoli cells.

The testis of the immature cat is unaffected by estrogen (Starkey and Leatham, 1939). Severe tubular atrophy and involution of the Leydig cells are noted in bulls (Ferrara, Rosati and Consoli, 1953) and boars (Wallace, 1949) after feeding with stilbestrol.

Although Haseck and Gütter (1951) found no effect of estrogen on the testis, the consensus is that any kind of estrogen produces profound involution of the human testis. Temporary sterility is induced, of course, as well as impotence and gynecomastia (Heckel and Steinmetz, 1941). Most of the information in man has been obtained from the therapeutic administration of estrogen in cases of prostatic carcinoma (Chomé, 1956; de la Balze, Mancini and Irazu, 1951; de la Balze, Bur, Irazu and Mancini, 1953; de la Balze, Mancini, Bur and Irazu, 1954; Schwartz, 1945; Schültz, 1952, to mention only a few) and from the administration of estrogen to hypersexual and homosexual men (Dunn, 1941). Estrogen induces atrophy of the tubules and the Leydig cells; the latter revert to fibroblasts. The germinal epithelium shows an increase in lipids and a decrease in glycogen. Unless other disease is present, the atrophy proceeds so that only the Sertoli cells remain in the tubules; even these cells may disappear with the induction of peritubular hyalinization and sclerosis.

#### C. ADRENAL STEROIDS

Tubular diameter in the testis of the mature rat remains normal despite the presence of severe hypercortinism resulting from administration of 3 mg. cortisone per day for 6 weeks (Winter, Silber and Stoerk, 1950) or of 5 to 10 mg. per day (Ingle, 1950). A few reports indicate that cortisone stimulates growth of the testes of young rats (Leroy, 1951) or causes degeneration of the germinal epithelium of the rat (Leroy, 1952) and mouse (Antopol, 1950). A careful study by Hanson, Blivaiss and Rosenzweig (1957) showed that the relative growth of the testis is stimulated only slightly by cortisone.

Extremely little information is available on the maintenance of spermatogenesis

in hypophysectomized rats by cortisone. Leroy and Domm (1952) reported maintenance at doses of 5 mg. per day. The Leydig cells involuted, and the secondary sexual apparatus was atrophic. However, these findings were not confirmed by Aterman (1956), who used 5 mg. hydrocortisone per day after hypophysectomy. The scrotum became atrophic and the testes retracted. The histologic appearance of the testes of the cortisone-treated animals was indistinguishable from that of the hypophysectomized controls. In rabbits Arambarri (1956) reported only small changes in the relative weight after prolonged use of cortisone. In man, fairly large doses of cortisone given to patients with rheumatoid arthritis do not affect the histologic appearance of the testes (Madlock, Chase and Nelson, 1953). Cortisone does bring about rapid testicular maturation in boys who have congenital adrenal hyperplasia, but only if the bone age is near the age of puberty (Wilkins and Cara, 1954). This must not be construed as a direct effect of cortisone on testicular maturation. The action of cortisone in this instance is to inhibit the excessive release of corticotrophin (ACTH) from the pituitary, thus reducing the amount of 17-ketosteroids produced by the abnormal adrenals. Removal of the inhibiting effect of the androgenic steroids allows the formation of gonadotrophin, with resulting maturation of the testes.

The consensus is that cortisone does not cause any change in the histologic appearance of the testis (Cavallero, Rossi and Borasi, 1951; Soulaïrac, Soulaïrac and Teyssere, 1955; Baumann, 1955). Furthermore, it causes no change in the accessory structures, or in the secretion of androgen by the testis. Cortisone has no direct effect on the prostate or seminal vesicles in castrated animals (Moore, 1953). It is doubtful whether cortisone can maintain spermatogenesis after hypophysectomy. The bearing of these studies on normal testicular physiologic function is questionable. Cortisone has been the main adrenal steroid studied in the rat but the rat adrenal secretes corticosterone, not cortisone.

Desoxycorticosterone has been administered to rats in various doses. Arvy (1942) and Overzier (1952) reported that the de-

velopment of the testis of the immature rat was arrested by prolonged injections of this steroid. Effects from desoxycorticosterone are not evident in adrenalectomized animals (Migeon, 1952). Adult rats show atrophy of both the tubular apparatus and the Leydig cells (Näätänen, 1955; Selye and Albert, 1942a, b). Maintenance of spermatogenesis after hypophysectomy was described by Overzier (1952).

Because cortisone even in massive doses has little effect on the testis, it would seem unlikely that ACTH would have any dramatic effects. Li and Evans (1947) reported that ACTH depresses testicular weight and the weight of the accessories in young rats, has no effect in old rats, and does not maintain spermatogenesis or the accessories in hypophysectomized rats. Baker, Schairer, Ingle and Li (1950) reported a small reduction in testicular weight in adult rats, but spermatogenesis proceeded satisfactorily. Large doses of ACTH produced atrophy of the Leydig cells. Asling, Reinhardt and Li (1951) stated that large doses depress the weight of the accessory sex organs. However, Moore (1953) found that administration of 5 mg. ACTH per day for 10 days has no effect on the testis of young or old rats and has no extratesticular effect on the production of androgen.

#### D. MISCELLANEOUS STEROIDS AND MIXTURES OF STEROIDS

Masson (1945, 1946) studied 16 different steroids for their ability to maintain spermatogenesis. Androstenediol, methylandrostenediol, methylandrostanediol,  $\Delta^5$ -pregneninolone, and dehydroisoandrosterone are the most active compounds in maintaining spermatogenesis after hypophysectomy. No relationship is apparent between the ability to maintain spermatogenesis and the androgenic activity of the compound as measured by stimulation of the seminal vesicles or the progestational activity (progesterone is effective in maintenance but ethinyl testosterone is not).

One compound,  $\Delta^5$ -pregneninolone, was studied in detail. It prevents testicular atrophy after hypophysectomy or following therapy with estradiol or testosterone; it does not produce atrophy of the Leydig cells. In doses of 1 to 2 mg. a day, preg-

neninolone maintains spermatogenesis in young and adult hypophysectomized rats, but it does not repair the tubules or Leydig cells after a 2-week delay between hypophysectomy and therapy. Pregneninolone also exerts a protective effect against the damage evoked by estradiol; however, it does not affect the regeneration that occurs after cessation of estradiol treatment. In this respect, it is different from testosterone, which hastens the recovery from the estradiol-induced damage. In fact, the acceleration of regeneration by testosterone is inhibited by pregnenolone. The chief difference between pregnenolone-progesterone and testosterone-androstenediol is that, whereas spermatogenesis is maintained by either pair after hypophysectomy, the former pair cannot restore spermatogenesis, and the latter can. Most of these effects of pregnenolone were confirmed by Dvoskin (1949). Progesterone and some new progestational compounds have been studied recently in man (Heller, Laidlaw, Harvey and Nelson, 1958). Progesterone given to normal men produces azoospermia and slight tubular atrophy, abolishes libido, and reduces potentia, but has no effect on the Leydig cells and the excretion of gonadotrophin, estrogen, and 17-ketosteroids.

Certain doses of desoxycorticosterone or estradiol have no effect on the testis singly, but when mixed produce severe depression of testicular weight (Jost and Lilman, 1952). The earlier work of Emmens and Parkes (1938), showing that testosterone inhibits the debilitating action of estrone, was confirmed by Joël (1942, 1945). The testes of animals treated with estradiol are one-sixth normal size; however, when testosterone propionate is added to the estrogen, the testicular weight is one-fourth normal. Furthermore, sperm cells are present in the epididymides of the group receiving testosterone. Mixtures of small amounts of androstenediol and estradiol in a constant proportion produce more profound atrophy than large doses given in the same constant proportion (Selye and Albert, 1942a, b; Selye, 1943). Furthermore, androstenediol and pregnenolone prevent the atrophy induced by small doses of testosterone. Hence, this protective action is not related to androgenic activity, because the first compound is

a weak androgen; the second has no androgenic action. The protective effect possibly is due to interference with the inhibiting action of testosterone on pituitary gonadotrophin.

#### **XIV. Effects of Altered Endocrine States on the Testis**

Apart from the pituitary, alterations in the endocrine system do not have pronounced effects on the testis. The thyroid has been studied extensively with regard to testicular function (Maqsood, 1952). It is difficult to generalize with respect to the total impact of the thyroid on the testis except to state that there is great variability not only from species to species, but also in different individuals of any one species. Young, Rayner, Peterson and Brown (1952a) suggested that the range of thyroid activity within which normal testicular function is possible is rather wide. This may explain why many effects on the testis of altered thyroid function are marginal and why so many reports are exceedingly conflicting. Furthermore, it seems reasonable that animals having a naturally high level of thyroid activity may be impaired with respect to reproductive performance when made hypothyroid; conversely, species or individuals functioning normally at relatively low levels of thyroid activity may be adversely affected with regard to testicular activity when made hyperthyroid (Young, Rayner, Peterson and Brown, 1952b).

In laboratory animals, hypothyroidism is induced by thyroidectomy, by feeding of antithyroid substances, by administering radioiodine, or by combination of these methods. Hyperthyroidism is induced by feeding desiccated thyroid or various artificial thyroproteins, or by injecting thyroxine or triiodothyronine. Because it does not seem to matter, as far as testicular physiology is concerned, how hypothyroidism and hyperthyroidism are induced, details of the method of altering thyroidal status will not be given.

Hypothyroid rats show decreased spermatogenesis and have smaller accessory structures than normal rats (Smelser, 1939a). However, Jones, Delfs and Foote (1946) found that adult hypothyroid rats sire litters. Young animals, made hypothyroid at birth or shortly thereafter, may show

delay in sexual maturation (Scow and Marx, 1945; Scow and Simpson, 1945), or may have normal reproductive tracts (Goddard, 1948). Hyperthyroid rats show testicular degeneration associated with a decrease in sperm production and androgen secretion. The deleterious effects of hyperthyroidism are attributed to an incapacity of the testis to respond to gonadotrophin. The atrophy of the accessory structures is attributed to the decrease in androgen production and to their increased requirement for androgen in states of hyperthyroidism (Smelser, 1939b). A nonendocrine explanation offered by Cunningham, King and Kessell (1941) is that testicular degeneration occurs because of the increased body heat of the animals in the hyperthyroid state. Richter and Winter (1947), however, stated that hyperthyroidism has a stimulating effect on the rat testis and accelerates the transfer of sperm through the genital ducts. Lenzi and Marino (1947) wrote that experimental hyperthyroidism causes a decrease in the number and volume of Leydig cells. Mixtures of thyroxine and testosterone in doses that have no effect on the rat testis when given singly, produce severe atrophy in normal rats (Masson and Romanchuck, 1945). Small doses of testosterone augment the debilitating effect of hyperthyroidism; large doses protect the testis (Roy, Kar and Datta, 1955). Changes in thyroidal status also appear to affect the responsiveness of the testis to gonadotrophins. Meites and Chandrashaker (1948) stated that hyperthyroidism decreases the responsiveness of the rat testis to exogenous gonadotrophin (PMS) whereas hypothyroidism increases it. The reverse holds for mice.

In growing mice, sexual development is retarded by hypothyroidism and accelerated by mild hyperthyroidism (Maqsood and Reineke, 1950). Moreover, the effectiveness of testosterone on the seminal vesicles of mice is increased by the concomitant administration of thyroxine (Masson, 1947), indicating an increased responsiveness of the accessory reproductive tract to male hormone in the hyperthyroid state.

Hyperthyroid guinea pigs have small testicular tubules and fewer sperm in the seminiferous tubules. As in the rat, Richter (1944) found that hyperthyroidism in the

guinea pig was associated with a rapid discharge of sperm through the genital ducts. Hypothyroidism was found to have no effect on the structure of the testis, on the structure of the sperm cells in the ejaculate, or on fertility (Shettles and Jones, 1942). Young, Rayner, Peterson and Brown (1952a, b), however, observed that the degree of fertility of hypothyroid guinea pigs was slightly reduced but in general the strength of the sex drive was not altered significantly by either hypothyroidism or hyperthyroidism.

Other laboratory animals studied include the rabbit and the dog. Hypothyroidism in beagle puppies has no effect on spermatogenesis (Mayer, 1947), whereas Maqsood (1951b) found atrophy of the seminiferous tubules and signs of decreased sexual drive in hypothyroid rabbits.

In male farm animals, alterations in thyroid function are associated with variable effects on the reproductive system. Atrophy of the tubules and Leydig cells occurs in the hypothyroid ram. Reduction of libido is noted in the hypothyroid ram, goat, and bull (Maqsood and Reineke, 1950). "Summer sterility" of sheep is explained as being due to depression of thyroid activity brought about by hot weather. Feeding thyroidal materials increases libido and spermatogenesis in bulls (Reineke, 1946; Petersen, Spielman, Pomeroy and Boyd, 1941). The reduction in testicular activity during hypothyroidism is attributed to an altered secretion of trophic hormones by the pituitary; the excess secretion of thyrotrophin induced by thyroid deficiency in some way reduces the secretion of gonadotrophins (De Bastiani, Sperti and Zatti, 1956).

In man, Marine (1939) reported atrophy of the Leydig cells in a case of myxedema and atrophy of the tubules in a case of exophthalmic goiter; however, examination of the accompanying photomicrographs is not convincing. Many conflicting claims of the effect of thyroidal materials in infertile men have been made (*cf.* Dickerson, 1947) but these studies are uncontrolled and deserve no further comment. A recent study by Farris and Colton (1958), if verified, indicates that the nature of the thyroid substance used may be important after all. Thyroxine and triiodothyronine were ad-

ministered to normal and subfertile men. Thyroxine depressed the number and activity of the sperm cells in the ejaculate, whereas triiodothyronine had a beneficial effect on the quality and motility of the spermatozoa.

Very little can be found on the effect of altered adrenal function on the testis. During the alarm reaction induced by the injection of formalin, no changes are evident in the testis when the adrenal cortex is undergoing its usual response (Croxatto and Chiriboga, 1951, 1952). Chronic hyperadrenalism produced by injections of epinephrine is accompanied occasionally by testicular atrophy and usually by regression of the accessories (Perry, 1941). Adrenalectomy in dogs, cats, and man is not followed by alteration in testicular structure (Morales and Hotchkiss, 1956).

In rats rendered diabetic by removal of 95 per cent of the pancreas, a slight decrease was observed in testicular weight. In the final stages of diabetic cachexia, however, severe testicular atrophy occurs (Foglia, 1945). Horstmann (1949, 1950) concluded that the impotence of diabetic men results from the combined effects of decreased androgen production and of increased androgen destruction. This conclusion was, however, denied by Bergqvist (1954). Impotency and loss of libido are encountered frequently in association with uncontrolled diabetes; both may be corrected by adequate therapy. However, men more than 35 years of age whose diabetes is well controlled may have irreversible loss of libido and potentia. Histologic evidence of atrophy in the testes of such diabetic men can be found in the literature. The atrophy described seems no greater than that which may occur spontaneously in normal men at various ages, however.

The pineal body has long been thought to be involved in the regulation of the testis. The following conflicting statements have been made: (1) administration of pineal extracts inhibits testicular development, (2) pinealectomy causes testicular hypertrophy, (3) the concentration of cholesterol esters in the testis is lowered by administration of pineal extracts, and (4) none of the above results are obtained (Simonet and Sternberg, 1951; Simonet

and Thieblot, 1951; Alcozer and Costa, 1954; Alcozer and Giordano, 1954; Bailo, 1955). The reader is referred to a recent book which summarizes the literature on the pineal body (Kitay and Altschule, 1954).

Extensive hepatic disease is associated with testicular atrophy. Morrione (1944) induced cirrhosis in male rats by means of carbon tetrachloride. The testes of the cirrhotic rats were not affected. However, when estrogen was administered, severe testicular atrophy occurred, much greater than that induced by the same amount of estrogen in control, noncirrhotic animals. Testicular atrophy is said to occur in 70 per cent of men who have cirrhosis of the liver (Bennett, Baggenstoss and Butt, 1951). There is no critical information from which one could conclude that the atrophy of the testis in cirrhotic men is caused by failure of the diseased liver to inactivate estrogen.

#### XV. Nonneoplastic Disorders of the Testis

Study of certain hypogonadal disorders of man has provided information of general interest and bearing on the physiology of the mammalian testis. For an index to the large clinical literature on pituitary-testis relationships, the reader may consult Heller and Nelson (1948) and Albert, Underdahl, Greene and Lorenz (1953-1955). A group of spontaneously occurring disorders shows clearly the control of the testis by gonadotrophin. In pituitary dwarfism, the testis remains infantile even as late as 30 or 40 years of age, and perhaps for the entire life span of the individual so afflicted. Leydig cells are not present, and the tubules contain only undifferentiated cells and occasional spermatogonia. Pituitary dwarfism is a form of hypopituitarism in which all hormones of the anterior lobe may be absent. Another type of hypogonadism in man is restricted to the loss of only the gonadotrophic function of the pituitary. In this syndrome, the testis does not contain mature Leydig cells or mature tubules. This syndrome represents a condition that cannot be duplicated in lower animals. A few instances of a selective type of gonadotrophic insufficiency have been described in which tubular maturation proceeds, with differentiation of the Sertoli cells and the

formation of sperm. However, Leydig cells are not present. This syndrome ("fertile eunuchs"), if interpreted in terms of the dualistic concept of pituitary control of the testis, is explainable on the basis that formation and secretion of FSH have occurred but that LH is absent. If pituitary lesions occur before puberty, the testes remain immature. Pituitary lesions occurring after maturity cause atrophy of the seminiferous epithelium, not immaturity. The adult tubule of man cannot dedifferentiate as does the mature Leydig cell following hypophysial deprivation. The atrophy may vary in severity from hypospermatogenesis to complete sclerosis. Lack of gonadotrophin in the adult also results in thickening of the tubular wall and atrophy of the Leydig cells.

The most common defect in the human testis is failure of the seminiferous tubules. In contrast to the pituitary deficiencies, which generally result in both tubular and androgenic failure, disorders of spermatogenesis lead only to infertility. The Leydig cells are normal, and androgenic function is unimpaired. The disordered spermatogenesis and the presence of cellular debris in the lumen are reflected by an abnormal spermiogram. Depression of the sperm count to the point of azoospermia, abnormal sperm cells, and poor motility are characteristic findings. Another type of primary testicular disorder associated with azoospermia is germinal aplasia, in which the tubules contain only Sertoli cells. The Leydig cells are normal; hence, androgenic function is normal. Klinefelter's syndrome also is associated with azoospermia but the function of the Leydig cells is variable, ranging from severe insufficiency, in which the afflicted persons are eunuchoidal, to mild insufficiency, in which the habitus is normal or almost so.

Testicular disorders are not restricted to man. They occur in common laboratory animals and in veterinary practice. Their similarity to some of the clinical entities just described will be evident.

A genito-urinary abnormality occurs in 20 per cent of males of the A x C rat (Vilar and Hertz, 1958). On one side, the testis is atrophic and the kidney, ureter, ductus deferens, epididymis, and seminal vesicle are absent; however, the coagulating gland is present. The testis is normal prepubertally



up to 10 days of age. The lumenless tubules contain two types of cells; one is a small cell with one nucleolus; the other is a large round cell containing two or three nucleoli. Oval cells resembling Leydig cells are present in the interstitium. At 19 to 24 days of age, both testes are equal in weight. The diameter of the tubules increases, a lumen is present, and the tubular wall becomes differentiated. Sertoli cells, spermatogonia, and spermatocytes are evident, and the Leydig cells are maturing. At 30 to 38 days of age, the testis on the abnormal side is noticeably smaller. The Leydig cells remain normal, but the tubules are decreased in size. Between 45 and 47 days of age, spermatogenesis ceases and the tubules become atrophic. Thick collagenous and elastic fibers are found in the tubular wall. This disorder seems to be an inherited defect with delayed somatic manifestations. In some aspects, the pathogenesis of this testicular disorder in rats resembles that in Klinefelter's syndrome.

Congenital spermatogenic hypoplasia occurs in guinea pigs (Jakway and Young, 1958). It ranges from germinal aplasia in most of the seminiferous tubules to a condition in which the appearance of the tubules is almost normal and the percentage of fertile matings is only slightly reduced. When sterility is present, the testes are smaller than those of normal males. The hormonal production, as reflected by the size of the penis and seminal vesicles and by sexual behavior, is normal.

The mule has a J-shaped chromosome which is contributed by the ass (Makino, 1955). Spermatogenesis in the mule does not proceed beyond meiotic prophase, degeneration occurring without formation of the metaphase of the first division. Hence, sperm cells will not form. The testes become atrophic, and only a few spermatogonia remain. The Leydig cells are normal.

Different types of hypogonadism, some of which are inherited, are encountered in bulls. Hypoplasia associated with urate crystals in the semen probably results from disintegration of the seminiferous epithelium (Barron and Haq, 1948). Idiopathic necrosis of the tubule also may cause massive testicular calcification (Barker, 1956). Seven cases of hypogonadism in Belgian bulls were

reported as a form of congenital sterility (Derivaux, Bienfait and Peers, 1955); photomicrographs of the testes in these cases are similar to those of germinal aplasia in the human. Testicular hypoplasia occurs also in goats (Rollinson, 1950).

Captive wild animals become sterile. Bushman, the famous gorilla at the Chicago Zoo, died at the age of approximately 22 years. Necropsy revealed neuropathy, cardiopathy, hemosiderosis, and testicular sclerosis (Steiner, Rasmussen and Fisher, 1955). No cells of the germinal epithelium were present except occasional Sertoli cells. The Leydig cells were normal. The testicular atrophy of Bushman was similar to that of Bobby, at the Berlin Zoo. Whether this degenerative testicular lesion is caused by nutritional deficiency or by the "stress" of captivity is not known.

## XVI. Tumors of the Testis

Testicular tumors are more common among lower animals than in man (Innes, 1942). Spontaneously occurring Sertoli-cell and Leydig-cell tumors of animals have been studied more than seminomas presumably because of the greater endocrinologic interest attached to them. Huggins and Pazos (1945) found 64 testicular tumors in 41 dogs; of these, 33 were Leydig-cell tumors, 19 were seminomas, 9 were tubular adenomas, and 3 were undifferentiated tumors. Zuckerman and McKeown (1938) found tumors in 35 of 243 dogs. A few of these were Sertoli-cell tumors which were associated with metaplasia of the prostate. The life span of dogs varies from 8 to 15 years, and testicular tumors occur most frequently at 7 years of age or older; in fact, more than half of old dogs are found to have such tumors (Scully and Coffin, 1952). The most common tumor of the dog testis is a Leydig-cell tumor. Five per cent of testicular tumors in dogs occur in undescended testes. The neoplasms in cryptorchid testes are usually Sertoli-cell tumors (Greulich and Burford, 1936; Coffin, Munson and Scully, 1952; Mulligan, 1944).

The veterinary diagnosis (Blum, 1954) of Sertoli-cell tumors is easily made, because the dogs become feminized. For this reason, the chief complaint of the owners is that normal male dogs, after a brief olfactory

reconnaissance, attempt to mount their afflicted pets. In addition to the feminization, evidence that Sertoli-cell tumors produce estrogen comes from the finding of estrogen in the urine of tumor-bearing animals and from the extraction of estrogen from the tumor itself (Berthrong, Goodwin and Scott, 1949). In terms of estradiol, the concentration of estrogen extracted from a Sertoli-cell tumor (Huggins and Moulder, 1945) was twice that found in the ovary from an estrous bitch. Sufficient estrogen appears to be produced to cause such changes as loss of hair, depression of libido, cystic hyperplasia of the mammary glands, and atrophy of the testis.

Interstitial cell tumors in dogs are usually nonfunctional, but they may produce estrogen (Laufer and Sulman, 1956; Kahan, 1955). Leydig-cell tumors have been reported in the mule, the Brahma bull, and the saddle horse (Smith, 1954). Significantly, in the last instance, an interstitial cell tumor occurred in the undescended testis of a 7-year-old horse, the descended testis having been removed early in life.

In man the proportion of various types of testicular tumors is different from that in lower animals. Seminomas and embryonal carcinomas are the most frequent neoplasms. Interstitial cell tumors have been recorded in less than two dozen instances in the world literature. Several cases of Leydig-cell tumor have been studied by Vennig (1942), Cook, Gross, Landing and Zygmuntowicz (1952), Hertz, Cohen, Lewis and Firminger (1953), and Jungck, Thrash, Ohlmaier, Knight and Dyrenforth (1957). This tumor causes isosexual precocity in boys. Signs of androgenic activity are evident in the large penis; scrotal maturation; the appearance of pubic, facial, and axillary hair, and acne; increased bodily growth; maturation of the larynx; and increased excretion of 17-ketosteroids. All these findings occur when sufficient amounts of testosterone are injected into normal prepubertal boys. This tumor cannot conceivably be related to the secretion of LH (see subsequent material on experimental tumors), because the neoplasms are usually unilateral and the contralateral normal testis shows no activation of the Leydig cells.

Neoplasms classified as Sertoli-cell tu-

mors are rich in lipids and are thought to secrete estrogen (Teilum, 1950). However, the histogenesis of these tumors is not clear, and there is doubt that Sertoli-cell tumors actually occur in man.

Testicular tumors have been induced in rats by transplantation of immature testes to the spleen of castrated adult animals (Biskind and Biskind, 1945) and by radiation, carcinogens, and other means (Peyron and Samsonoff, 1941). Transplantation of day-old rat testes to the spleen of castrated adult rats, normal male rats, and castrated adult female rats resulted in the formation of encapsulated and sharply circumscribed tumors. Of 29 tumors thus produced, 16 were composed entirely of interstitial cells and 13 contained other testicular elements as well. One of the tumors was transplantable into the spleen of a castrated animal. Because hyperplasia of the interstitial cells was seen in most of the transplanted testes, it was thought that the neoplasia followed the hyperplasia induced by the excess of gonadotrophin in the castrated host (Twombly, Meisel and Stout, 1949). Such Leydig-cell tumors produce estrogen (Fels and Bur, 1956).

In contrast with the rat, experimental tumors in the mouse are not induced by any of the methods already mentioned (Gardner, 1953). Spontaneous tumors of the testis in mice do occur, however. Slye, Holmes and Wells (1919) found 28 testicular tumors in some 9000 male mice. None formed metastatic lesions. Hummel (1954) reported a spontaneous tumor in an 18-month-old mouse of the BALBC strain; this neoplasm was transplantable for three generations in normal or gonadectomized adult males or females. This was a functioning tumor as evidenced by masculinization of the submaxillary glands, mucification of the vagina, hypertrophy of the clitoris, and an increase in size of the uterus of the female host and of the accessory sex organs of the male host. All these findings indicate estrogenic and androgenic secretion. In general, however, interstitial cell tumors in mice are strain-limited, occurring particularly in the AC and JK strains. Spontaneous interstitial cell tumors also occur in hybrids and are associated with mammary tumors (Gardner, Pfeiffer, Trentin and Wolstenholme, 1953).

This association indicates that estrogen is involved in the formation of the tumor; indeed, it is chiefly by the use of estrogen that experimental tumors in mice have been provoked.

Various natural and synthetic estrogens are effective. For example, Hooker, Gardner and Pfeiffer (1940) and Hooker and Pfeiffer (1942) using estradiol and stilbestrol have been able to produce interstitial cell tumors in the A and C strains of mice, with an incidence of 50 and 90 per cent respectively. Treatment for 8 months with 16.6 to 50  $\mu\text{g}$ . of estradiol dibenzoate or 0.25  $\mu\text{g}$ . stilbestrol weekly produces tumors, some of which metastasize to the renal, lumbar, and mediastinal lymph nodes. These tumors are transplantable if the hosts are given estrogen. They are inhibited by the simultaneous injection of testosterone. Tumors also may be induced by implantation of pellets of stilbestrol and cholesterol. The implantation of a 4- to 6-mg. pellet of 10 to 25 per cent stilbestrol in cholesterol induced tumors within 5 months (Shimkin, Grady and Andervont, 1941). Of the various natural and synthetic estrogens the triphenylethylene derivatives appear to be the most potent. Bonser (1942) and Gardner (1943) produced transplantable tumors in the JK, the A, and the C 3H strains by triphenylethylene. Tumors thus induced are generally composed of interstitial cells. They are transplantable only in the same strain of mice and only when the hosts are given estrogen. After several generations, however, the tumor may be transplanted without administration of estrogen in normal and in hypophysectomized mice (Gardner, 1945; Andervont, Shimkin and Canter, 1957).

The tumors arise from hyperplastic interstitial cells. The Leydig cells enlarge, become foamy, and degenerate. Macrophages or, at least, cells containing a brown pigment appear and phagocytose the exhausted Leydig cells. A new crop of interstitial cells appears from the mesenchyme. These may grow faster in one zone than in another. The faster-growing Leydig cells thus constitute a nodule. The Leydig cells in the nodule also become hyperplastic and foamy. These nodules appear as white spots and cause pressure atrophy of the tubules. Leydig cells in

the tumor thus result from three generations, since the second crop of Leydig cells is followed by a third generation containing small primitive and hyperchromatic cells. These contain brown pigment and hence give the brown color to the tumor. At this stage, the tumor may become necrotic, may metastasize by way of lymph or blood, or may invade locally. Such tumors secrete both estrogen and androgen. The consensus is that estrogen induces interstitial cell tumors in mice by liberation of LH (Gardner, 1953).

The assumption that LH induces interstitial cell hyperplasia and finally a tumor has received support from studies by Simpson and van Wagenen (1954) on young monkeys. These investigators gave ICSH for 53 days. Hyperplasia of the Leydig cells took place and nodules resulted. These nodules were composed of concentric laminated peritubular cells and arose from the same type of mesenchymal cell that yields the Leydig cell under normal conditions. Under the influence of HCG, the nodules secreted androgen.

## XVII. Conclusion

The postnatal development of the mammalian testis follows a fairly definite pattern. Development is slow for the variable period of prepubertal life. The testis then undergoes rapid evolution during puberty, remains fairly constant in adult life, then regresses somewhat in old age. The rapid development of the testis during puberty is brought about by the onset of gonadotrophic function of the pituitary. This developmental pattern is fixed for each species, but can be modified by genic and environmental factors. Once the adult status is attained, secretory controls of androgenic and spermatogenic functions are established. A steady state of testicular function is maintained in continuously breeding species. In those mammals which show a seasonal breeding cycle, these secretory controls, particularly those of the pituitary gland, are periodically activated and deactivated.

The testes of many eutherian mammals migrate from the abdomen during fetal life to the scrotum. This migration is regulated by hormones of the fetus, presumably arising from the fetal testis. It is not clear just

why the testes occupy the scrotum. The explanation that scrotal residence provides "optimal testicular temperature" is not satisfying because one then wishes to know why the male gonad requires the cooler environment afforded by the scrotum. Failure of the testes to descend may occur as a consequence of defects in the testes, probably of genic origin; or because of anatomic obstacles, representing embryologic defects, inadvertently placed along its prescribed narrow path. In either event, the testis is damaged, mildly in its endocrine function, and seriously in its spermatogenic function.

Impairment of spermatogenesis of the misplaced testis is due to the relatively high temperature of the abdomen. Temperature affects the germinal epithelium directly. It also affects the testis indirectly through the circulatory system. The effect of temperature, or for that matter, of any type of injurious agent whether it be chemical or physical, is atrophy of the seminiferous epithelium. The response of the germinal tissue to deprivation of pituitary gonadotrophin likewise is atrophy. Quantitative variation among different species does of course exist, but qualitatively, atrophy is the universal response to injury. Obviously, a common denominator must exist for this fairly general reaction on the part of the germinal epithelium. If various chemical and physical stimuli act on the testis by means of suppression or interference with the action of gonadotrophins, atrophy of the Leydig cells would also result. However, many chemical and physical agents affect only the germinal epithelium, leaving the Leydig cells unscathed. Thus, the germinal epithelium can be damaged directly and the variable damage to the components of the spermatogenic epithelium must be due to different sensitivities of its cellular components. The Sertoli cell is much more resistant than the cells of the germinal line, and of the seminiferous elements, the type A spermatogonia are the most resistant. Of great importance in the interpretation of the damage induced by many substances or occurring as a result of disease is the characteristic of the germinal epithelium to reproduce in a fixed order and sequence. It follows that the extent of injury to spermatogenesis as a whole would be determined

by the relative susceptibility of the various germinal cells as well as by the nature of the noxious agent. If only sperm cells are affected, spermatogenesis will proceed through the formation of spermatid. However, if spermatogonia are injured, full differentiation of the germinal epithelium will fail, and only Sertoli cells will be found in the tubule. Thus, it is possible that all sorts of injury to the testis, if sufficiently great, may result in the same end stage of testicular atrophy. In spite of this common reaction pattern to severe injury, many substances induce what seem to be specific lesions in the testis. However, these represent intermediate or partial injuries, and do not necessarily constitute exceptions to the general pattern of testicular response to injury. As more is learned about the biochemistry of the germinal epithelium, it may be possible to induce specific lesions.

Quantitative studies on spermatogenesis have greatly clarified the role played by the pituitary gland. Spermatogenesis does proceed in hypophysectomized animals but only at a low rate. Also it appears that androgen, not gonadotrophin, is responsible for the maturation of the spermatid. However, it must be remembered that the formation of androgen is dependent on pituitary gonadotrophic function. Thus spermatogenesis is regulated entirely by pituitary gonadotrophins, which exert direct supervision over the rate of the mitotic and meiotic activity of germ cells and indirect supervision by way of the Leydig cell over spermatid maturation, or spermiogenesis. The effectiveness of androgen in sperm formation is hardly equal to that of the pituitary. Addition of trophic hormones (except gonadotrophin) or of hormones of the target glands (thyroid, adrenal cortical hormone, etc.) will probably not improve the effectiveness of androgen. The best evidence that this surmise may be correct is obtained from patients with hypogonadotrophic hypogonadism. These patients have normal function with respect to the other trophic hormones of the pituitary and, therefore, normally functioning peripheral glands, but do not have sperm.

The quantitative studies on the spermatogenic cycle have important bearing on other problems which have been puzzling to endo-

crinologists. Many unsuccessful attempts have been made to induce precocious sperm formation in the rat by chronic or massive use of various gonadotrophins. The time of a complete spermatogenic cycle is not accurately known. Estimates ranging from 20 to 40 days have been given, which reflects the difficulties and errors of present methods. If one adds to the time at which sperm formation normally occurs in common strains of the laboratory rat (around 35 days of age), about 10 days borrowed from fetal life, the time of a complete spermatogenic cycle is probably between 45 and 50 days. Hence, no amount of exogenous gonadotrophin could be expected to produce precocious spermatogenesis, because a certain irreducible minimum of time may be required for the series of divisions which *in toto* constitutes a spermatogenic cycle. However, if the interval between birth and maturity is much longer than the time of a complete spermatogenic cycle, precocious spermatogenesis could be experimentally achieved, as is again indicated by an example from clinical endocrinology, *i.e.*, the spontaneous occurrence of isosexual precocity in boys.

In another clinical area, the application of quantitative techniques to the study of testes of patients afflicted with infertility has so far not yielded helpful information. Restoration of fertility in men with adult seminiferous tubular failure has not been accomplished. Infertility, however, is receiving increasing attention, especially from the standpoint of genic factors. It is in this area that the only startling development of knowledge on the testis in the past 20 years has occurred, *i.e.*, the discovery that men with Klinefelter's syndrome are "genetic females." One may, with good reason, question the suitability of the term "genetic females." It arose from the application of Barr's discovery of sex dimorphism in the heterochromatin of somatic cells (Barr, 1956; Barr and Bertram, 1949; Moore and Barr, 1955). Normal females are "chromatin positive"; normal males are "chromatin negative." This, however, may not be absolute. Men with Klinefelter's syndrome are chromatin positive, and if chromatin positivity reflects genic constitution, it is likely that the sterility of men with this syndrome

(one of its outstanding features) represents an abnormality of chromosomal division or number during gametogenesis of one of their parents. Generally similar situations may occur in lower animals; hence, the role of genic factors in fertility can be studied experimentally.

Great advances have taken place in knowledge of the biosynthesis of male hormone by the testis. Illumination of the chemical pathway over which simple precursors (acetate) or more complex ones (cholesterol) are transformed to testosterone represents a major contribution in biochemistry. The enzymatic control of the various chemical steps will undoubtedly be disclosed before long.

### XVIII. References

- ALBERT, A., UNDERDAHL, L. O., GREENE, L. F., AND LORENZ, N. 1953a. Male hypogonadism. I. The normal testis. Proc. Staff Meet., Mayo Clin., **28**, 409.
- ALBERT, A., UNDERDAHL, L. O., GREENE, L. F., AND LORENZ, N. 1953b. Male hypogonadism. II. Classification. Proc. Staff Meet., Mayo Clin., **28**, 557.
- ALBERT, A., UNDERDAHL, L. O., GREENE, L. F., AND LORENZ, N. 1953c. Male hypogonadism. III. The testis in pituitary dwarfism. Proc. Staff Meet., Mayo Clin., **28**, 698.
- ALBERT, A., UNDERDAHL, L. O., GREENE, L. F., AND LORENZ, N. 1954a. Male hypogonadism. IV. The testis in prepubertal or pubertal gonadotrophic failure. Proc. Staff Meet., Mayo Clin., **29**, 131.
- ALBERT, A., UNDERDAHL, L. O., GREENE, L. F., AND LORENZ, N. 1954b. Male hypogonadism. V. The testis in adult patients with multiple defects of pituitary function. Proc. Staff Meet., Mayo Clin., **29**, 317.
- ALBERT, A., UNDERDAHL, L. O., GREENE, L. F., AND LORENZ, N. 1954c. Male hypogonadism. VI. The testis in gonadotrophic failure in adults. Proc. Staff Meet., Mayo Clin., **29**, 368.
- ALBERT, A., UNDERDAHL, L. O., GREENE, L. F., AND LORENZ, N. 1955. Male hypogonadism. VII. The testis in partial gonadotrophic failure during puberty (lack of luteinizing hormone only). Proc. Staff Meet., Mayo Clin., **30**, 31.
- ALCOZER, G., AND COSTA, U. 1954. Comportamento delle frazioni colesteroliche nel testicolo di cavia adulta trattata con estratto acquoso di pineale. Arch. "E. Maragliano" pat. e clin., **9**, 355.
- ALCOZER, G., AND GIORDANO, G. 1954. Rapporti epifiso-testicolari; modificazioni istologiche del testicolo di cavia adulta e di topino adulto dopo somministrazione di estratto acquoso di ghiandola pineale. Arch. "E. Maragliano" pat. e clin., **9**, 433.

- ALLEN, H., AND ALLAND, P. D. 1952. Studies of degenerating sex cells in immature mammals. II. Modes of degeneration in the normal differentiation of the definitive germ cells in the male albino rat from age twelve days to maturity. *J. Morphol.*, **91**, 515.
- ALNOR, P. 1951. Zur Frage der Beeinflussung der Sexualfunktion durch Resektion des lumbalen Grenzstranges. *Arch. klin. Chir.*, **269**, 506.
- ANDERVONT, H. B., SHIMKIN, M. B., AND CANTER, H. Y. 1957. Effect of discontinued estrogenic stimulation upon the development and growth of testicular tumors in mice. *J. Nat. Cancer Inst.*, **18**, 1.
- ANTHONY, A. 1953. Seasonal reproductive cycle in the normal and experimentally treated male prairie dog, *Cynomys ludovicianus*. *J. Morphol.*, **93**, 331.
- ANTLIFE, H. R., AND YOUNG, W. C. 1957. Internal secretory capacity of the abdominal testis in the guinea pig. *Endocrinology*, **61**, 121.
- ANTOPOL, W. 1950. Anatomic changes produced in mice treated with excessive doses of cortisone. *Proc. Soc. Exper. Biol. & Med.*, **73**, 262.
- ARAMBARI, M. L. 1956. Die Wirkung von hohen Cortisondosen auf das Hodenzwischengewebe des Kaninchens. *Ztschr. ges. exper. Med.*, **127**, 227.
- ARVY, L. 1942. L'hypophyse et l'acétate de désoxycorticostérone. *Compt. rend. Soc. biol.*, **136**, 660.
- ASDELL, S. A. 1946. *Patterns of Mammalian Reproduction*. Ithaca: Comstock Publishing Company, Inc.
- ASLING, C. W., REINHARDT, W. O., AND LI, C. H. 1951. Effects of adrenocorticotrophic hormone on body growth, visceral proportions, and white blood cell counts of normal and hypophysectomized male rats. *Endocrinology*, **48**, 534.
- ATERMAN, K. 1956. Cortisol and spermiogenesis. *Acta endocrinol.*, **22**, 371.
- BACON, R. L., AND KIRKMAN, H. 1955. The response of the testis of the hamster to chronic treatment with different estrogens. *Endocrinology*, **57**, 255.
- BADENOCH, A. W. 1945. Descent of the testis in relation to temperature. *Brit. M. J.*, **2**, 601.
- BAHN, R. C., LORENZ, N., BENNETT, W. A., AND ALBERT, A. 1953a. Gonadotrophins of the pituitary gland and the urine of the adult human female. *Endocrinology*, **52**, 135.
- BAHN, R. C., LORENZ, N., BENNETT, W. A., AND ALBERT, A. 1953b. Gonadotrophins of the pituitary gland and urine of the adult human male. *Proc. Soc. Exper. Biol. & Med.*, **82**, 777.
- BAHN, R. C., LORENZ, N., BENNETT, W. A., AND ALBERT, A. 1953c. Gonadotrophins of the pituitary gland during infancy and early childhood. *Endocrinology*, **52**, 605.
- BAHN, R. C., LORENZ, N., BENNETT, W. A., AND ALBERT, A. 1953d. Gonadotrophins of the pituitary of postmenopausal women. *Endocrinology*, **53**, 155.
- BAILO, P. 1955. Intercellazioni pinealo-testicolari con particolare riferimento alla terapia dell'iperepotismo; osservazioni cliniche e ricerche istologiche sperimentali. *Minerva ginec.*, **7**, 677.
- BAKER, B. L., SCHAUBER, M. A., INGLE, D. J., AND LI, C. H. 1950. The induction of involution in the male reproductive system by treatment with adrenocorticotrophin. *Anat. Rec.*, **106**, 345.
- BALLERIO, L. 1954. Sulla supposta produzione di estrogeni da parte del testicolo; contributo istochimico. *Arch. ital. urol.*, **27**, 278.
- BANDMANN, F. 1950. Weitere Beobachtungen über die Hodenfunktion nach lumbaler Grenzstrangresektion. *Beitr. klin. Chir.*, **181**, 419.
- BARKER, C. A. V. 1956. Some observations on testicular calcification in bulls. *Canad. J. Comp. Med.*, **20**, 37.
- BARR, M. L. 1956. The sex chromatin and its bearing on errors of sex development. *Canad. M. A. J.*, **74**, 419.
- BARR, M. L., AND BERTRAM, E. G. 1949. A morphologic distinction between neurones of the male and female, and the behavior of the nucleolar satellite during accelerated nucleoprotein synthesis. *Nature, London*, **163**, 676.
- BARROX, N. S., AND HAQ, I. 1948. Ammonium urate in the semen of bulls with testicular hypoplasia. *Vet. Rec.*, **60**, 155.
- BAUMANN, W. 1955. Die Wirkung von hohen Cortisondosen auf das Hodenzwischengewebe der weissen Ratte. *Ztschr. ges. exper. Med.*, **126**, 116.
- BEALL, D. 1940. The isolation of  $\alpha$ -estradiol and estrone from horse testes. *Biochem. J.*, **34**, 1293.
- BENNETT, H. S., BAGGENSTOSS, A. H., AND BUTT, H. R. 1951. Testis, breast, and prostate of men who die of cirrhosis of the liver. *Proc. Staff Meet., Mayo Clin.*, **26**, 33.
- BERQVIST, N. 1951. The gonadal function in male diabetics. *Acta endocrinol.*, Suppl. 18, 3.
- BERTHONG, M., GOODWIN, W. E., AND SCOTT, W. W. 1949. Estrogen production by the testis. *J. Clin. Endocrinol.*, **9**, 579.
- BIDDULPH, C. 1939. The effect of testosterone propionate on gonadal development and gonadotrophic hormone secretion in young male rats. *Anat. Rec.*, **73**, 447.
- BISHOP, D. H., AND LEATHAM, J. H. 1946. Response of prepubertal male mice to equine gonadotrophin. *Anat. Rec.*, **95**, 313.
- BISHOP, D. H., AND LEATHAM, J. H. 1948. Effect of equine gonadotrophin on prepubertal male mice. *Exper. Med. & Surg.*, **6**, 28.
- BISKIND, M. S., AND BISKIND, G. R. 1945. Tumor of rat testis produced by heterotransplantation of infantile testis to spleen of adult castrate. *Proc. Soc. Exper. Biol. & Med.*, **59**, 4.
- BLAIR, J. H., SNIFFEN, R. C., CRANSWICK, E. H., JAFFEE, W., AND KLINE, N. S. 1952. The question of histopathologic changes in the testes of schizophrenics. *J. Ment. Sci.*, **98**, 464.
- BLUM, A. G. 1951. Sertoli cell tumor in a dog. *Vet. Med.*, **49**, 343.
- BOND, C. R. 1945. The golden hamster (*Cricetus*

- auratus*); care, breeding, and growth. *Physiol. Zögl.*, **18**, 52.
- BONSER, G. M. 1942. Malignant tumors of the interstitial cells of the testis in Strong A mice treated with triphenylethylene. *J. Path. & Bact.*, **54**, 149.
- BORS, E., ENGLE, E. T., ROSENQUIST, R. C., AND HOL-LIGER, V. H. 1950. Fertility in paraplegic males; a preliminary report of endocrine studies. *J. Clin. Endocrinol.*, **10**, 381.
- BOURG, R., VAN MEENSEL, F., AND GOSPEL, G. 1952. Action des doses massives de benzoate d'oestradion au niveau des testicules du rat adulte. *Ann. endocrinol.*, **13**, 195.
- BRADY, R. O. 1951. Biosynthesis of radioactive testosterone *in vitro*. *J. Biol. Chem.*, **193**, 145.
- BURGOS, M. H., AND FAWCETT, D. W. 1955. Studies on the fine structure of the mammalian testis. I. Differentiation of the spermatids in the cat (*Felis domestica*). *J. Biophys. & Cytol.*, **1**, 287.
- CALZOLARI, G., PULITO, G., AND PASQUINELLI, F. 1950. Ricerche biometriche sul comportamento del testicolo residuo dopo asportazione dell'altro nella cavia. I. Il comportamento del pìso. *Boll. Soc. ital. biol. sper.*, **26**, 467.
- CARMON, J. L., AND GREEN, W. W. 1952. Histologic study of the development of the testis of the ram. *J. Anim. Sci.*, **11**, 674.
- CAVALIERO, C., ROSSI, L., AND BORASI, M. 1951. Studio sperimentale sugli effetti del cortisone. III. Effetti morfologici sulle ghiandole endocrine del ratto. *Sperimentale*, **101**, 226.
- CIALICE, C. E. 1953. Electron microscope studies of spermiogenesis in some rodents. *J. Roy. Microscop. Soc.*, **73**, 115.
- CHARNY, C. W., CONSTIN, A. S., AND MERANZE, D. R. 1952. Testicular developmental histology. *Ann. New York Acad. Sci.*, **55**, 597.
- CHOMÉ, J. 1956. Influence des oestrogènes de synthèse sur la structure histologique du testicule. *Presse méd.*, **64**, 971.
- CLERMONT, Y. 1951. Cycle de l'épithélium séminal et mode de renouvellement des spermatogonies chez le hamster. *Rev. canad. biol.*, **13**, 208.
- CLERMONT, Y. 1958. The morphology of the seminiferous tubules and their distribution in the testis of one adult albino rat (Abstr.). *Anat. Rec.*, **130**, 287.
- CLERMONT, Y., AND LEBLOND, C. P. 1953. Renewal of spermatogonia in the rat. *Am. J. Anat.*, **93**, 475.
- CLERMONT, Y., AND LEBLOND, C. P. 1955. Spermiogenesis of man, monkey, ram, and other mammals as shown by the "periodic acid-Schiff" technique. *Am. J. Anat.*, **96**, 229.
- CLERMONT, Y., AND MORGENTHAU, H. 1955. Quantitative study of spermatogenesis in the hypophysectomized rat. *Endocrinology*, **57**, 369.
- CLERMONT, Y., AND PEREY, B. 1957. Quantitative study of the cell population of the seminiferous tubules in immature rats. *Am. J. Anat.*, **100**, 241.
- COFFIN, D. L., MUNSON, T. O., AND SCULLY, R. E. 1952. Functional Sertoli cell tumor with metastasis in a dog. *A. Vet. M. A. J.*, **121**, 352.
- COOK, C. D., GROSS, R. E., LANDING, B. H., AND ZYGUNTOWICZ, A. S. 1952. Interstitial cell tumor of the testis; study of a 5-year-old boy with pseudoprecocious puberty. *J. Clin. Endocrinol.*, **12**, 725.
- COOPER, E. R. A. 1929. The histology of the retained testis in the human subject at different ages, and its comparison with the serotal testis. *J. Anat.*, **64**, 5.
- COOPER, I. S., AND HOEN, T. I. 1949. Gynecomastia in paraplegic males; report of seven cases. *J. Clin. Endocrinol.*, **9**, 457.
- COOPER, I. S., AND HOEN, T. I. 1952. Metabolic disorders in paraplegics. *Neurology*, **2**, 332.
- COOPER, I. S., RYNEARSON, E. H., BAILEY, A. A., AND MACCARTY, C. S. 1950. The relation of spinal cord diseases to gynecomastia and testicular atrophy. *Proc. Staff Meet., Mayo Clin.*, **25**, 320.
- COOPER, I. S., RYNEARSON, E. H., MACCARTY, C. S., AND POWER, M. H. 1950. Metabolic consequences of spinal cord injury. *J. Clin. Endocrinol.*, **10**, 858.
- COUJARD, R. 1952. Effets sur le testicule et l'épididyme de la phénolisation des fibres nerveuses. *Compt. rend. Soc. biol.*, **146**, 704.
- COUJARD, R. 1954. Contribution à l'étude des voies nerveuses sympathiques du testicule. *Arch. anat. microscop.*, **43**, 321.
- CROXATTO, O. C., AND CHIRIBOGA, J. 1951. Estudio anatómico de suprarrenales, bazo y testículos de cobayos durante la reacción de alarma y fase de resistencia. *An. Cáted. pat. y clín. tuberc.*, **13**, 103.
- CROXATTO, O. C., AND CHIRIBOGA, J. 1952. Estudio anatómico de suprarrenales, bazo y testículos de cobayos durante la reacción de alarma y fase de resistencia. *Medicina*, Buenos Aires, **12**, 37.
- CUNNINGHAM, B., KING, J. T., AND KESSELL, H. R. 1941. Hyperthyroidism and sterility in the white rat (Abstr.). *Anat. Rec., suppl.*, **81**, 31.
- CUNNINGHAM, B., MAY, J., AND GORDON, S. 1942. Presence of estrogenic hormone(s) in testicular material. *Proc. Soc. Exper. Biol. & Med.*, **49**, 130.
- CUTLTY, E., AND CUTLTY, E. C. 1940. Observations on spermatogenesis in rats. *Endocrinology*, **26**, 503.
- DAoust, R., AND CLERMONT, Y. 1955. Distribution of nucleic acids in germ cells during the cycle of the seminiferous epithelium in the rat. *Am. J. Anat.*, **96**, 255.
- DAVIDSON, H. A. 1954. Treatment of male subfertility; testicular temperature and varicoceles. *Practitioner*, **173**, 703.
- DEANESLY, R. 1954. Spermatogenesis and endocrine activity in grafts of frozen and thawed rat testis. *J. Endocrinol.*, **11**, 201.
- DE BASTIANI, G., SPERTI, L., AND ZATTI, P. 1956. Effetti della tiroidectomia e della somministrazione dell'ormone tireotropo ipofisario sull'attività delle gonadi, nella cavia. I. Testicoli. *Boll. Soc. ital. biol. sper.*, **32**, 393.
- DE LA BALZE, F. A., BUR, G. E., IRAZI, J., AND MENCINI, R. E. 1953. Étude des changements

- morphologiques et histochimiques produits par les oestrogènes dans les testicules adultes humains. *Ann. endocrinol.*, **14**, 509.
- DE LA BALZE, F. A., BUR, G. E., SCARPA-SMITH, F., AND IRAZU, J. 1954. Elastic fibers in the tunica propria of normal and pathologic human testes. *J. Clin. Endocrinol.*, **14**, 626.
- DE LA BALZE, F. A., MANCINI, R. E., BUR, G. E., AND IRAZU, J. 1954. Morphologic and histochemical changes produced by estrogens on adult human testes. *Fertil. & Steril.*, **5**, 421.
- DE LA BALZE, F. A., MANCINI, R. E., AND IRAZU, J. 1951. Cáncer de próstata-acción de los estrogénos sobre los testículos. *Rev. argent. urol.*, **20**, 241.
- DERIVAUX, J., BIENFAIT, V., AND PEERS, W. 1955. L'hypogonadisme mâle chez les bovidés. *Bruxelles-méd.*, **35**, 1642.
- DICKERSON, D. L. 1947. Some aspects of thyroid function in relation to infertility. *West. J. Surg.*, **55**, 343.
- DICZFALUSY, E., HOLMGREN, H., AND WESTERMAN, A. 1950. The action of human chorionic gonadotrophin preparations on the adrenals and testicles of hypophysectomized immature rats. *Acta endocrinol.*, **5**, 43.
- DIRSCHLER, W., AND BREUER, H. 1955. Über Steroide des menschlichen Spermas. *Acta endocrinol.*, **19**, 30.
- DISCHREIT, J. 1939. Wirkung des Testikelhormonpräparates Ergon auf den juvenilen Rattenhoden. *Klin. Wehnschr.*, **18**, 1493.
- DISCHREIT, J. 1940. Studien über Follikelhormonwirkung auf die Keimdrüsen juveniler männlicher Ratten. *Monatsschr. Kinderh.*, **84**, 137.
- DUNN, C. W. 1941. Stilbestrol induced testicular degeneration in hypersexual males. *J. Clin. Endocrinol.*, **1**, 643.
- DVOSKIN, S. 1944. Local maintenance of spermatogenesis by intratesticularly implanted pellets of testosterone in hypophysectomized rats. *Am. J. Anat.*, **75**, 289.
- DVOSKIN, S. 1949. The effect of pregnenolone on re-initiation and maintenance of spermatogenesis in hypophysectomized rats. *Endocrinology*, **45**, 370.
- EMMENS, C. W., AND PARKES, A. S. 1938. The estrogens of the testis and of the adrenal in relation to the treatment of enlarged prostate with testosterone propionate. *J. Path. & Bact.*, **47**, 279.
- ENGBERG, H. 1949. Investigations on the endocrine function of the testicle in cryptorchidism. *Proc. Roy. Soc. Med.*, **42**, 652.
- ENGLE, E. T. 1955. Aspects of aging as reflected in the human ovary and testis. *Recent Progr. Hormone Res.*, **9**, 291.
- FARRIS, E. J., AND COLTON, S. W. 1958. Effects of L-thyroxine and lithium on spermatogenesis (Abstr.). *Anat. Rec.*, **130**, 407.
- FARRIS, E. J., AND GRIFFITH, J. Q. (Editors). 1949. *The Rat in Laboratory Investigation*, Ed. 2. Philadelphia: J. B. Lippincott Company.
- FELS, E., AND BUR, G. E. 1956. Tumores del injerto testicular en el bazo de la rata castrada. *Rev. Soc. argent. biol.*, **32**, 115.
- FERNER, H., AND RUNGE, W. 1956. Histochemische Untersuchungen zur Frage der endokrinen Aktivität der Hodenzwischenzellen Während der Fetalzeit beim Menschen. *Ztschr. Zellforsch. mikroskop. Anat.*, **45**, 39.
- FERRARA, B., ROSATI, P., AND CONSOLI, G. 1953. Azione degli stilbenici sul testicolo; ricerche sperimentali in ovis aries. *Boll. Soc. ital. biol. sper.*, **29**, 66.
- FEVOLD, H. L. 1944. The gonadotrophic function of the pituitary gland. In *The Chemistry and Physiology of Hormones*, F. R. Moulton, Ed., p. 152. Washington, D. C.: American Association for the Advancement of Science.
- FINKEL, M. P. 1945. The relation of sex hormones to pigmentation and to testis descent in the opossum and ground squirrel. *Am. J. Anat.*, **76**, 93.
- FOGLIA, V. G. 1945. El peso de los órganos de la rata diabética. *Rev. Soc. argent. biol.*, **21**, 45.
- GAARENSTROOM, J. H. 1941. An analysis of the effect of chorionic gonadotrophic hormone on the rat testis. *Arch. internat. pharmacodyn.*, **66**, 121.
- GARDNER, J. H. 1949. Effects of injection of  $\alpha$ -estradiol on testes and thyroids of albino rats. *Proc. Soc. Exper. Biol. & Med.*, **72**, 306.
- GARDNER, W. U. 1943. Testicular tumors in mice of several strains receiving triphenylethylene. *Cancer Res.*, **3**, 92.
- GARDNER, W. U. 1945. Some influences of hormones on the growth and persistence of transplanted testicular tumors. *Cancer Res.*, **5**, 497.
- GARDNER, W. U. 1953. Hormonal aspects of experimental tumorigenesis. *Proc. Am. A. Cancer Res.*, **1**, 173.
- GARDNER, W. U., PFEIFFER, C. A., TRENTIN, J. L., AND WOLSTENHOLME, J. T. 1953. Hormonal factors in experimental carcinogenesis. In *The Physiopathology of Cancer; A Treatise for Investigators, Physicians and Students*, F. Hamburger, and W. H. Fishman, Eds., p. 225. New York: Paul B. Hoeber, Inc.
- GETZOFF, P. L. 1955. Clinical evaluation of testicular biopsy and the rebound phenomenon. *Fertil. & Steril.*, **6**, 465.
- GLOVER, T. D. 1956. The effect of scrotal insulation and the influence of the breeding season upon fructose concentration in the semen of the ram. *J. Endocrinol.*, **13**, 235.
- GODDARD, R. F. 1948. Anatomic and physiologic studies in young rats with propylthiouracil-induced dwarfism. *Anat. Rec.*, **101**, 539.
- GOLDZIEFER, J. W., AND ROBERTS, I. S. 1952. Identification of estrogen in the human testis. *J. Clin. Endocrinol.*, **12**, 143.
- GOTHE, S., AND MORICARD, R. 1939. Étude biométrique de la régression testiculaire chez le rat hypophysectomisé. *Compt. rend. Soc. biol.*, **131**, 196.
- GRANT, J. H. 1956. The effects of unilateral orchidectomy on the rat testis. In *Studies on Fertility*, R. G. Harrison, Ed., p. 27. Springfield, Ill.: Charles C Thomas.



- GRAY, D. J. 1947. The intrinsic nerves of the testis. *Anat. Rec.*, **98**, 325.
- GREENE, R. R., AND BURRILL, M. W. 1940. The recovery of testes after androgen-induced inhibition. *Endocrinology*, **26**, 516.
- GREENE, R. R., AND BURRILL, M. W. 1941. Effects of large amounts of androgen on the testes of the prepubertal rat. *Endocrinology*, **29**, 64.
- GREEP, R. O. 1937. Pituitary regulation of the male gonad. Cold Spring Harbor Symposia Quant. Biol., **5**, 136.
- GRESSON, R. A. R. 1950. A study of the male germ-cells of the rat and the mouse by phase-contrast microscopy. *Quart. J. Microscop. Sci.*, **91**, 73.
- GRESSON, R. A. R., AND ZLOTNIK, I. 1945. A comparative study of the cytoplasmic components of the male germ-cells of certain mammals. *Proc. Roy. Soc. Edinburgh, ser. B*, **62**, 137.
- GRESSON, R. A. R., AND ZLOTNIK, I. 1948. A study of the cytoplasmic components during gametogenesis of *Bos taurus*. *Quart. J. Microscop. Sci.*, **89**, 219.
- GRELICH, W. W., AND BURFORD, T. H. 1936. Testicular tumors associated with mammary, prostatic, and other changes in cryptorchid dogs. *Am. J. Cancer*, **28**, 496.
- GROSS, R. E., AND JEWETT, T. C., JR. 1956. Surgical experiences from 1222 operations for undescended testis. *J. A. M. A.*, **160**, 634.
- GUNN, S. A., AND GOULD, T. C. 1958. The presence of an inherent reproductive cycle in the male laboratory rat. *J. Endocrinol.*, **17**, 341.
- HAINES, W. J., JOHNSON, R. H., GOODWIN, M. P., AND KUIZENGA, M. H. 1948. Biochemical studies on hog testicular extract. I. Isolation and identification of 5-pregn-3( $\beta$ )-ol-20-one. *J. Biol. Chem.*, **174**, 925.
- HAMILTON, J. B., AND LEONARD, S. L. 1938. The effect of male hormone substance upon the testes and upon spermatogenesis. *Anat. Rec.*, **71**, 105.
- HANES, F. M., AND HOOKER, C. W. 1937. Hormone production in the undescended testis. *Proc. Soc. Exper. Biol. & Med.*, **35**, 549.
- HANSON, R. O., BLIVAISS, B. B., AND ROSENZWEIG, R. E. 1957. Sexual development in male rats treated with cortisone. *Am. J. Physiol.*, **183**, 281.
- HARRIS, R., AND HARRISON, R. G. 1955. The effect of low temperature on the guinea pig testis. In *Studies on Fertility*, R. G. Harrison, Ed., vol. 7, p. 23. Springfield, Ill.: Charles C Thomas.
- HARRISON, R. G. 1948a. Vascular patterns in the testis, with particular reference to Macropus. *Nature, London*, **161**, 399.
- HARRISON, R. G. 1948b. The blood supply of the testis in relation to problems of sterility. In *Conference on Infertility*, p. 14. London: Family Planning Association.
- HARRISON, R. G. 1949a. The distribution of the vasa and cremasteric arteries to the testis and their functional importance. *J. Anat.*, **83**, 267.
- HARRISON, R. G. 1949b. The comparative anatomy of the blood-supply of the mammalian testis. *Proc. Zool. Soc., London*, **119**, 325.
- HARRISON, R. G. 1952. Functional importance of the vascularization of the testis and epididymis for the maintenance of normal spermatogenesis. *Fertil. & Steril.*, **3**, 366.
- HARRISON, R. G. 1953a. The effect of ligation of vasa efferentia on the rat. In *Studies on Fertility*, R. G. Harrison, Ed., p. 97. Springfield, Ill.: Charles C Thomas.
- HARRISON, R. G. 1953b. Influence of unilateral orchidectomy on effect of ischemia on contralateral testis. In *Studies on Fertility*, R. G. Harrison, Ed., vol. 5, p. 101. Springfield, Ill.: Charles C Thomas.
- HARRISON, R. G., AND BARCLAY, A. E. 1948. The distribution of the testicular artery (internal spermatic artery) to the human testis. *Brit. J. Urol.*, **20**, 57.
- HARRISON, R. G., AND HARRIS, R. 1956. Thermoregulation of the testis at high temperatures. In *Studies on Fertility*, R. G. Harrison, Ed., p. 76. Springfield, Ill.: Charles C Thomas.
- HARRISON, R. G., AND MACMILLAN, E. W. 1951. The effects of high epididymal obstruction upon the Leydig cell volume of the rat testis. *J. Endocrinol.*, **11**, 89.
- HARRISON, R. G., AND WEINER, J. S. 1949. Vascular patterns of the mammalian testis and their functional significance. *J. Exper. Biol.*, **26**, 304.
- HARTMAN, C. G., MILLMAN, N., AND STAVORSKI, J. 1950. Vasodilatation of the rat testis in response to human chorionic gonadotropin. *Fertil. & Steril.*, **1**, 443.
- HASCHEK, H., AND GÖTTER, W. 1951. Zur Frage der Atrophie des menschlichen Hodens nach Behandlung mit dem Follikelhormonwirkstoff Relaton. *Klin. med.*, **6**, 177.
- HECKEL, N. J., AND McDONALD, J. H. 1952a. The rebound phenomenon of the spermatogenic activity of the human testis following the administration of testosterone propionate; further observations. *Fertil. & Steril.*, **3**, 49.
- HECKEL, N. J., AND McDONALD, J. H. 1952b. The effects of testosterone propionate upon the spermatogenic function of the human testis. *Ann. New York Acad. Sc.*, **55**, 725.
- HECKEL, N. J., ROSSO, W. A., AND KESTEL, L. 1951. Spermatogenic rebound phenomenon after administration of testosterone propionate. *J. Clin. Endocrinol.*, **11**, 235.
- HECKEL, N. J., AND STEINMETZ, C. R. 1941. The effect of female sex hormone on the function of the human testis. *J. Urol.*, **46**, 319.
- HEINKE, E., AND TONUTTI, E. 1956. Studien zur Wirkung des Testosterons auf die spermiogenetische Aktivität des Hodens bei Oligospermie. *Deutsche med. Wchnschr.*, **81**, 566.
- HELLER, C. G., LAIDLAW, W. M., HARVEY, H. T., AND NELSON, W. O. 1958. Effects of progestational compounds on the reproductive processes of the human male. *Ann. New York Acad. Sc.*, **71**, 649.
- HELLER, C. G., AND NELSON, W. O. 1947. Evidence that chorionic gonadotrophic hormone stimulates Leydig cells to produce androgen

- and that follicle-stimulating hormone stimulates spermatogenesis in man. In *XVIIIth International Physiological Congress: Abstracts of Communication*, p. 273. Great Britain.
- HELLER, C. G., AND NELSON, W. O. 1948. The testis-pituitary relationship in man. *Recent Progr. Hormone Res.*, **3**, 229.
- HELLER, C. G., NELSON, W. O., HILL, I. B., HENDERSON, E., MADDOCK, W. O., JUNGCK, E. C., PAULSEN, C. A., AND MORTIMORE, G. E. 1950. Improvement in spermatogenesis following depression of the human testis with testosterone. *Fertil. & Steril.*, **1**, 415.
- HELLER, C. G., PAULSEN, C. A., MORTIMORE, G. E., JUNGCK, E. C., AND NELSON, W. O. 1952. Urinary gonadotrophins, spermatogenic morphology—their bearing on the utilization hypothesis. *Ann. New York Acad. Sc.*, **55**, 685.
- HEMPHILL, R. E. 1944. The significance of atrophy of the testis in schizophrenia. *J. Ment. Sc.*, **90**, 696.
- HEMPHILL, R. E., AND REISS, M. 1945. Serum gonadotrophin and testis biopsy in the treatment of schizophrenia. *J. Ment. Sc.*, **91**, 1.
- HEMPHILL, R. E., REISS, M., AND TAYLOR, A. L. 1944. A study of the histology of the testis in schizophrenia and other mental disorders. *J. Ment. Sc.*, **90**, 681.
- HERTZ, R., COHEN, M. I., LEWIS, L. G., AND FIRMINGER, H. I. 1953. Sexual precocity in a 5-year-old boy with interstitial cell tumor of the testis. *J. Clin. Endocrinol.*, **13**, 1248.
- HINGLAIS, H., AND HINGLAIS, M. 1951. Action du prolan B sur l'irrigation sanguine du testicule des rongeurs. *Compt. rend. Soc. biol.*, **145**, 178.
- HOOKE, C. W. 1944. The postnatal history and function of the interstitial cells of the testis of the bull. *Am. J. Anat.*, **74**, 1.
- HOOKE, C. W. 1948. Biology of interstitial cells of testis. *Recent Progr. Hormone Res.*, **3**, 173.
- HOOKE, C. W., GARDNER, W. U., AND PFEIFFER, C. A. 1940. Testicular tumors in mice receiving estrogens. *J. A. M. A.*, **115**, 443.
- HOOKE, C. W., AND PFEIFFER, C. A. 1942. The morphology and development of testicular tumors in mice of the A strain receiving estrogens. *Cancer Res.*, **2**, 759.
- HORSTMANN, P. 1949. The function of the endocrine glands in diabetes mellitus: a clinical study of 107 cases. *Acta endocrinol.*, **2**, 379.
- HORSTMANN, P. 1950. The excretion of androgens in human diabetes mellitus. *Acta endocrinol.*, **5**, 261.
- HOTCHKISS, R. S. 1944a. Effects of massive doses of testosterone propionate upon spermatogenesis. *J. Clin. Endocrinol.*, **4**, 117.
- HOTCHKISS, R. S. 1944b. *Fertility in Men: A Clinical Study of the Causes, Diagnosis, and Treatment of Impaired Fertility in Men*. Philadelphia: J. B. Lippincott Company.
- HOWARD, A., AND PELC, R. 1950.  $^{222}\text{Rn}$  autoradiographs of mouse testis; preliminary observations of the timing of spermatogenic stages. *Brit. J. Radiol.*, **23**, 631.
- HUGGINS, C., MASINA, M. H., EICHELBERGER, L., AND WHARTON, J. D. 1939. Qualitative studies of prostatic secretion. I. Characteristics of the normal secretion; the influence of thyroid, suprarenal, and testis extirpation and androgen substitution on the prostatic output. *J. Exper. Med.*, **70**, 543.
- HUGGINS, C., AND MOULDER, P. V. 1945. Estrogen production by Sertoli cell tumors of the testis. *Cancer Res.*, **5**, 510.
- HUGGINS, C., AND PAZOS, R., JR. 1945. Studies on tumors of the testis. II. Morphology of testicular tumors of dogs. *Am. J. Pathol.*, **21**, 299.
- HUGGINS, C., AND RUSSELL, P. S. 1946. Quantitative effects of hypophysectomy on testis and prostate of dogs. *Endocrinology*, **39**, 1.
- HUMMEL, K. P. 1954. A spontaneous transplantable testis tumor in a mouse (Abstr.). *Proc. A. A. Cancer Res.*, **1**, 21.
- INGLE, D. J. 1950. The biologic properties of cortisone; a review. *J. Clin. Endocrinol.*, **10**, 1312.
- INNES, J. R. M. 1942. Neoplastic diseases of the testis in animals. *J. Path. & Bact.*, **54**, 485.
- JAKWAY, J. S., AND YOUNG, W. C. 1958. An inherited spermatogenic hypoplasia in the guinea pig. *Fertil. & Steril.*, **9**, 533.
- JÄNKÄLÄ, E. O., AND NÄÄTÄNEN, E. K. 1955. Effect of intense mental strain on the morphologic picture of the testes. *Ann. med. exper. et biol. Fenniae*, **33**, 231.
- JOËL, C. A. 1942. Action of gynecogenic and androgenic hormones on the gonads and pituitary gland of mature male rats. *Endocrinology*, **31**, 64.
- JOËL, C. A. 1945. Degeneration und Regeneration des Hodens unter besonderer Berücksichtigung der Wirkung gynökogener und androgenen Wirkstoffe auf Männliche Gonaden Reifer Albino-Ratten. *Acta anat.*, **1**, 327.
- JONES, G. E. S., DELFS, E., AND FOOTE, E. C. 1946. The effect of thiouracil hypothyroidism on reproduction in the rat. *Endocrinology*, **38**, 337.
- JOSIMOVICH, J. B. 1958. Effects of destruction of the thoracic spinal cord on spermatogenesis in the mouse (Abstr.). *Endocrinology*, **63**, 254.
- JOST, A., AND LIBMAN, E. 1952. Atrophie testiculaire sous l'action combinée de la désoxycorticostérone et de l'oestradiol chez le rat. *Ann. endocrinol.*, **13**, 651.
- JUNGCK, E. C., THIRASU, A. M., OHLMACHER, A. P., KNIGHT, A. M., AND DYKENFORTH, L. Y. 1957. Sexual precocity due to interstitial cell tumor of the testis; report of 2 cases. *J. Clin. Endocrinol.*, **17**, 291.
- KAHAN, I. H. 1955. An atypical case of interstitial cell tumor of the testicle in a dog. *A. Vet. M. A. J.*, **126**, 471.
- KEMP, T., PEDERSEN-BJERGAARD, K., AND MADSEN, G. B. 1943. Effect of gonadotrophic hormones in the male organism. *Acta path. et microbiol. scandinav.*, **20**, 633.
- KEYE, J. D., JR. 1956. Hyperplasia of Leydig cells in chronic paraplegia. *Neurology*, **6**, 68.
- KIMBLE, D. J. 1948. Excretion of 17-ketosteroids by male rabbits during altered gonadal function. *Endocrinology*, **43**, 83.

- KING, A. B., AND LANGWORTHY, O. R. 1940. Testicular degeneration following interruption of the sympathetic pathways. *J. Urol.*, **44**, 74.
- KIRKPATRICK, C. M. 1955. The testis of the fox squirrel in relation to age and seasons. *Am. J. Anat.*, **97**, 229.
- KITAY, J. I., AND ALTSCHULE, M. D. 1951. *The Pineal Gland: A Review of the Physiologic Literature*. Cambridge, Mass.: Harvard University Press.
- KLEIN, M., FONTAINE, R., STOLL, G., DANY, A., AND FRANK, P. 1952. Modifications histologiques des testicules chez les paraplégiques. *Rev. neur.*, **86**, 501.
- KLEIN, M., AND MAYER, G. 1942. Effets provoqués par des injections de testostérone sur le testicule en ectopie expérimentale. *Arch. physiq. biol.*, suppl. **16**, 13.
- KMIENT, O. H. 1951. Über Steigerungen der Geschlechtsfunktionen ein Schliesslich der Spermienogenese nach Novocain-Blockaden des humeralen Geizstranges. *Zentralbl. Chir.*, **76**, 23.
- LACASSAGNE, A., CHAMORRO, A., AND BUC-HÖF, N. P. 1950. Sur quelques actions biologiques de la 4-hydroxypropiophénone. *Compt. rend. Soc. biol.*, **144**, 95.
- LADMAN, A. J., AND YOUNG, W. C. 1958. An electron microscopic study of the ductuli efferentes and rete testis of the guinea pig. *J. Biophys. & Biochem. Cytol.*, **4**, 219.
- LAUFER, A., AND SULMAN, F. G. 1956. Estrogenic Leydig-cell tumor with multiple metastases in a dog; the problem of bisexual hormone production by gonadal cells. *J. Clin. Endocrinol.*, **16**, 1151.
- LEATHEN, J. H. 1942. Effect of testosterone propionate on spermatogenesis in hypophysectomized rats following the injection of gonadotrophins. *Anat. Rec.*, **83**, 579.
- LEATHEN, J. H. 1944. Influence of testosterone propionate on the adrenals and testes of hypophysectomized rats. *Anat. Rec.*, **89**, 155.
- LEBLOND, C. P. 1950. Distribution of periodic acid-reactive carbohydrates in the adult rat. *Am. J. Anat.*, **86**, 1.
- LEBLOND, C. P., AND CLERMONT, Y. 1952a. Spermogenesis of rat, mouse, hamster and guinea pig as revealed by the "periodic acid-fuchsin sulfuric acid" technique. *Am. J. Anat.*, **90**, 167.
- LEBLOND, C. P., AND CLERMONT, Y. 1952b. Definition of the stages of the cycle of the seminiferous epithelium in the rat. *Ann. New York Acad. Sc.*, **55**, 548.
- LENZI, E., AND MARINO, C. 1947. Modificazioni istologiche prodotte nel testicolo e nell'ovaio dalla tirostossicosi sperimentale sub-acute e cronica (con particolare riguardo alla biometria delle cellule interstiziali). *Arch. "de Vecchi" anat. pat.*, **9**, 711.
- LEROY, P. 1951. Effets de la cortisone sur le testicule des mammifères et des oiseaux. *Compt. rend. Acad. sc.*, **233**, 976.
- LEROY, P. 1952. The effect of cortisone on the testes of adult and immature rats. *Anat. Rec.*, **113**, 590.
- LEROY, P., AND DOMM, L. V. 1952. Dissociation spermatogénétique, sous l'influence de la cortisone, chez le rat adulte, surrénalectomisé et hypophysectomisé. *Compt. rend. Acad. sc.*, **234**, 2230.
- LI, C. H., AND EVANS, H. M. 1947. Properties of growth and adrenocorticotrophic hormones. *Vitamins & Hormones*, **5**, 197.
- LUDWIG, D. J. 1950. The effect of androgen on spermatogenesis. *Endocrinology*, **46**, 453.
- LYNCH, K. M., JR. 1952. Recovery of the rat testis following estrogen therapy. *Ann. New York Acad. Sc.*, **55**, 734.
- MACLEOD, J., AND HOTCHKISS, R. S. 1941. The effect of hyperpyrexia upon spermatozoa counts in men. *Endocrinology*, **28**, 780.
- MACMILLAN, E. W. 1956. The immediate effects of occlusion of superior epididymal arteries in the rat as demonstrated by the use of radioactive medium. In *Studies on Fertility*, R. G. Harrison, Ed., p. 67. Springfield, Ill.: Charles C Thomas.
- MADDOCK, W. O., CHASE, J. D., AND NELSON, W. O. 1953. The effects of large doses of cortisone on testicular morphology and urinary gonadotrophin, estrogen, and 17-ketosteroid excretion. *J. Lab. & Clin. Med.*, **41**, 608.
- MADDOCK, W. O., EISEN, M., AND NELSON, W. O. 1952. The assay of urinary estrogens as a test of human Leydig cell function. *Ann. New York Acad. Sc.*, **55**, 657.
- MADDOCK, W. O., AND NELSON, W. O. 1952. The effects of chorionic gonadotrophin in adult men: increased estrogen and 17-ketosteroid excretion, gynecomastia, Leydig cell stimulation, and seminiferous tubule damage. *J. Clin. Endocrinol.*, **12**, 985.
- MAKINO, S. 1955. Notes on the cytologic feature of male sterility in the mule. *Experientia*, **11**, 224.
- MANNING, W. K. 1950. Biotin deficiency as the causative agent of induced cryptorchidism in albino rats. *Science*, **112**, 89.
- MAQSOOD, M. 1951a. Seasonal variations in the testis histology of the ram. *Vet. Rec.*, **63**, 597.
- MAQSOOD, M. 1951b. Influence of thyroid status on spermatogenesis. *Science*, **114**, 693.
- MAQSOOD, M. 1952. Thyroid functions in relation to reproduction of mammals and birds. *Biol. Rev.*, **27**, 281.
- MAQSOOD, M., AND REINEKE, E. P. 1950. Influence of environmental temperatures and thyroid status on sexual development in male mouse. *Am. J. Physiol.*, **162**, 24.
- MARESCAUX, J. 1950. Mécanisme d'action de la folliculine sur le testicule chez le cobaye. *Compt. rend. Soc. biol.*, **144**, 1102.
- MARESCAUX, J., AND DEMINATTI, M. 1955. Nouvelles recherches sur la fonction gonadostimulante de la préhypophyse par la méthode des greffes intratesticulaires combinées d'ovaire et de pars distalis chez le cobaye. *Compt. rend. Soc. biol.*, **149**, 1019.
- MARINE, D. 1939. Atrophy changes in the im-

- stitial cells of the testes in Gull's disease. *Arch. Path.*, **28**, 65.
- MARTINS, T. 1943. Mechanism of the descent of the testicle under the action of sex hormones. In *Essays in Biology, In Honor of Herbert M. Evans Written by "His Friends."* Thomas Cowles, Ed., p. 389. Berkeley and Los Angeles: University of California Press.
- MASON, K. E., AND SHAEVER, S. L. 1952. Some functions of the caput epididymis. *Ann. New York Acad. Sc.*, **55**, 585.
- MASSON, G. 1945. Spermatogenic activity of various steroids. *Am. J. M. Sc.*, **209**, 324.
- MASSON, G. 1946. The spermatogenic activity of  $\Delta^5$ -pregnenolone and of its esters. *Am. J. M. Sc.*, **212**, 1.
- MASSON, G. 1947. Action de la thyroxine sur l'effet testiculaire de la testostérone. *Rev. canad. biol.*, **6**, 355.
- MASSON, G., AND ROMANCHUCK, M. 1945. Observations sur certains changements morphologiques produits par la thyroxine et la testostérone. *Rev. canad. biol.*, **4**, 206.
- MAY, R. M. 1955. Induction de la spermiogénèse dans des testicules atrophiés de souris hypophysectomisées par la greffe brérophlastique d'une hypophyse sous leur albuginée. *Ann. endocrinol.*, **16**, 375.
- MAYER, E. 1947. Inhibition of thyroid function in beagle puppies by propylthiouracil without disturbance of growth or health. *Endocrinology*, **40**, 165.
- McCULLAGH, E. P., AND HRUBY, F. J. 1949. Testis-pituitary interrelationship: the relative inability of testosterone to reduce urinary gonadotrophin in castrated men. *J. Clin. Endocrinol.*, **9**, 113.
- McCULLAGH, E. P., AND SCHAFFENBURG, C. A. 1952. The role of the seminiferous tubules in the production of hormones. *Ann. New York Acad. Sc.*, **55**, 674.
- MEITES, J., AND CHANDRASHEKAR, B. 1948. Effect of thyroid status on response of the gonads to pregnant mares' serum in two different species (Abstr.). *J. Anim. Sc.*, **7**, 542.
- MESS, B. 1952. Influence of hypothalamic injury on spermatogenesis in albino rats. *Acta morphol.*, **2**, 275.
- MIGON, C. J. 1952. Effect of cortisone on lipids of serum, liver, and testes in intact and adrenalectomized rats. *Proc. Soc. Exper. Biol. & Med.*, **80**, 571.
- MOON, H. D., AND LI, C. H. 1952. Effect of follicle-stimulating hormone on gonads of immature C57 black mice. *Proc. Soc. Exper. Biol. & Med.*, **79**, 505.
- MOORE, C. R. 1937. Testis hormone secretion and some effects of the hormone in the organism. *Cold Spring Harbor Symposia Quant. Biol.*, **5**, 115.
- MOORE, C. R. 1939. Biology of the testes. In *Sex and Internal Secretions*, 2nd ed., E. Allen, C. H. Danforth and E. A. Doisy, Eds., p. 353. Baltimore: The Williams & Wilkins Company.
- MOORE, C. R. 1942. The physiology of the testis and application of male sex hormone. *J. Urol.*, **47**, 31.
- MOORE, C. R. 1944. Hormone secretion by experimental cryptorchid testes. *Yale J. Biol. & Med.*, **17**, 203.
- MOORE, C. R. 1951. Experimental studies on the male reproductive system. *J. Urol.*, **65**, 497.
- MOORE, C. R. 1953. Adrenal cortical secretions in relation to the reproductive system of rats. *J. Clin. Endocrinol.*, **13**, 330.
- MOORE, C. R., AND MORGAN, C. F. 1942. Responses of the testis to androgenic treatments. *Endocrinology*, **30**, 990.
- MOORE, C. R., AND MORGAN, C. F. 1943. First response of developing opossum gonads to equine gonadotrophic treatment. *Endocrinology*, **32**, 17.
- MOORE, K. L., AND BARR, M. L. 1955. Smears from the oral mucosa in the detection of chromosomal sex. *Lancet*, **2**, 57.
- MORALES, P. A., AND HOTCHKISS, R. S. 1956. Effect of adrenalectomy on the testes of man and the dog. *Fertil. & Steril.*, **7**, 487.
- MORIT, S. 1956. Morphologic studies on testis: mainly histochemical observations on the testicular functions. *Acta scholae med. Univ. Kioto*, **34**, 1.
- MORRISON, T. G. 1944. Effect of estrogens on the testis in hepatic insufficiency. *Arch. Path.*, **37**, 39.
- MOSSMAN, H. W., HOFFMAN, R. A., AND KIRKPATRICK, C. M. 1955. The accessory genital glands of male gray and fox squirrels correlated with age and reproductive cycles. *Am. J. Anat.*, **97**, 257.
- MÜLLER, I. 1957. Kanälchen- und Capillararchitektonik des Rattenhodens. *Ztschr. Zellforsch. mikroskop. Anat.*, **45**, 522.
- MULLIGAN, R. M. 1944. Feminization in male dogs: a syndrome associated with carcinoma of the testis and mimicked by the administration of estrogens. *Am. J. Path.*, **20**, 865.
- MUSCHKE, H. E. 1953. Histometrische Untersuchungen am Rattenhoden nach Hypophysektomie und nach Choriogonadotropinzufuhr. *Endokrinologie*, **30**, 281.
- MUSSIO FOURNIER, J. C., ESTEFAN, J. C., GROSSO, O., AND ALBREUX, A. 1947. Effets du stilboestrol et de la testostérone sur l'ascension et la descente du testicule chez les rats. *Ann. endocrinol.*, **8**, 109.
- NÄÄTÄNEN, E. K. 1955. The combined effect of puerperon and psychic stress on the spermatogenesis of rats. *Ann. Acad. Sc. Fenn., ser. A, V Med. Anthropol.*, **5**, 3.
- NELSON, W. O. 1937. Some factors involved in the control of the gametogenic and endocrine functions of the testis. *Cold Spring Harbor Symposia Quant. Biol.*, **5**, 123.
- NELSON, W. O. 1941. Renewal of sperm formation in hypophysectomized rats (Abstr.). *Anat. Rec.*, **79**, 48.
- NELSON, W. O. 1951. Mammalian spermatogenesis: effect of experimental cryptorchidism in

- the rat and nondescent of the testis in man. Recent Progr. Hormone Res., **6**, 29.
- NELSON, W. O. 1953. Some problems of testicular function. *J. Urol.*, **69**, 325.
- NELSON, W. O., AND HELLER, C. G. 1945. Hyalinization of the seminiferous tubules associated with normal or failing Leydig-cell function; microscopic picture in the testis and associated changes in the breast. *J. Clin. Endocrinol.*, **5**, 13.
- NELSON, W. O., AND MERCKEL, C. 1937. Maintenance of spermatogenesis in testis of the hypophysectomized rat with sterol derivatives. *Proc. Soc. Exper. Biol. & Med.*, **36**, 825.
- OAKBERG, E. F. 1956a. A description of spermiogenesis in the mouse and its use in analysis of the cycle of the seminiferous epithelium and germ cell renewal. *Am. J. Anat.*, **99**, 391.
- OAKBERG, E. F. 1956b. Duration of spermatogenesis in the mouse and timing of stages of the cycle of the seminiferous epithelium. *Am. J. Anat.*, **99**, 507.
- OETTLÉ, A. G., AND HARRISON, R. G. 1952. The histologic changes produced in the rat testis by temporary and permanent occlusion of the testicular artery. *J. Path. & Bact.*, **64**, 273.
- OKKELS, H., AND SAND, K. 1940-1941. Morphologic relationship between testicular nerves and Leydig cells in man. *J. Endocrinol.*, **2**, 38.
- OVERZIER, C. 1952. Über die Einwirkung des Desoocorticoesteronacetats auf die Hoden normaler und hypophysektomierter weiblicher Ratten. *Arch. path. Anat.*, **321**, 559.
- PALLOS, K. V. 1941. Über den Einfluss längere Zeit hindurch verabreichter grosser Mengen natürlicher und synthetischer oestrogenen Stoff auf die Hoden erwachsener männlicher Ratten. *Arch. Gynäk.*, **171**, 471.
- PARKES, A. S. 1954. Transplantation of testis tissue after storage at very low temperatures. *J. Endocrinol.*, **10**, viiP.
- PARKES, A. S., AND SMITH, A. U. 1954. Storage of testicular tissue at very low temperatures. *Brit. M. J.*, **1**, 315.
- PASQUINELLI, F., AND CALZOLARI, G. 1951. Ricerche sul comportamento del testicolo residuo dopo asportazione dell'altro nella cavia. *Sperimentale*, **101**, 257.
- PAULSEN, C. A. 1952. Gonadotrophin suppression as a result of the conversion of androgen to estrogen (Abstr.). *J. Clin. Endocrinol.*, **12**, 915.
- PERRY, J. C. 1941. Gonad response of male rats to experimental hyperadrenalism. *Endocrinology*, **29**, 592.
- PETERS, H. 1957. Über die feinere Innervation des Hodens insbesondere des interstitiellen Gewebes und der Hodenkanälchen beim Menschen. *Acta neuroveg.*, **15**, 235.
- PETERSEN, W. E., SPIELMAN, A., POMEROY, B. S., AND BOYD, W. L. 1941. Effect of thyroidectomy upon sexual behavior of the male bovine. *Proc. Soc. Exper. Biol. & Med.*, **46**, 16.
- PÉTROVIC, A., DEMINATTI, M., AND WEILL, C. 1954. Résultats de l'implantation de fragments hypophysaires dans le testicule de cobayes mûrs; leur signification au sujet des modalités de l'action gonadostimulante de la préhypophyse. *Compt. rend. Soc. biol.*, **148**, 383.
- PÉTROVIC, A., WEILL, C., AND DEMINATTI, M. 1954. Mode d'action quantitative de l'extrait hypophysaire sur le testicule chez le cobaye. *Compt. rend. Soc. biol.*, **148**, 593.
- PÉTROVITCH, A., WEILL, C., AND DEMINATTI, M. 1953. Implantation de fragments préhypophysaires dans le testicule de cobayes prépubères; leur action sur la glande interstitielle et sur les cellules sexuelles. *Compt. rend. Soc. biol.*, **147**, 495.
- PEYRON, A., AND SAMSONOFF, N. 1941. Sur la production expérimentale des tumeurs de la glande interstitielle du testicule chez le rat. *Compt. rend. Soc. biol.*, **135**, 922.
- PFEIFFER, E. W. 1956. The male reproductive tract of a primitive rodent, *Aplodontia rufa*. *Anat. Rec.*, **124**, 629.
- POLLOCK, W. F. 1942. Histochemical studies of the interstitial cells of the testis. *Anat. Rec.*, **84**, 23.
- POPOFF, N. 1947. Le tissu interstitiel du testicule dans diverses espèces. *Schweiz. med. Wchnschr.*, **77**, 931.
- POYNTER, H. 1939. Testis hormone secretion in the rat under conditions of vasectomy or isolation. *Anat. Rec.*, **74**, 355.
- PRELOG, V., TAGMANN, E., LIEBERMAN, S., AND RUCZICKA, L. 1947. Untersuchungen über Organextrakte; über Keto-steroide aus Schweinestestes-Extrakten. *Helvet. chim. acta*, **30**, 1080.
- RABINOWITZ, J. L., AND RAGLAND, J. B. 1958. Biosynthesis of radioactive estradiol and cholesterol by testicular homogenates from C-14 mevalonic acid (Abstr.). *Fed. Proc.*, **17**, 293.
- RABOCH, J., AND ZÁHOŘ, Z. 1956. Ein Beitrag zum Studium der inkretorischen Hodenfunktion bei Kryptorchismus. *Endokrinologie*, **33-34**, 160.
- REA, C. E. 1939. Functional capacity of the undescended testis. *Arch. Surg.*, **38**, 1054.
- REINEKE, E. P. 1946. The effect of synthetic thyroprotein on sterility in bulls. In *The Problem of Fertility*, E. T. Engle, Ed., p. 233. Princeton: Princeton University Press.
- RICHTER, K. M. 1944. Some new observations bearing on the effect of hyperthyroidism on genital structure and function. *J. Morphol.*, **74**, 375.
- RICHTER, K. M., AND WINTER, C. A. 1947. A quantitative study of the effect of hyperthyroidism on genital structure and function. *Am. J. Physiol.*, **150**, 95.
- RIEMERSCHMID, G., AND QUINLAN, J. 1941. Further observations on the scrotal skin temperature of the bull, with some remarks on the intratesticular temperature. *Onderst. J. Vet. Sc.*, **17**, 123.
- ROBINSON, J. N., AND ENGLE, E. T. 1954. Some observations on the cryptorchid testis. *J. Urol.*, **71**, 726.
- ROLLINSON, D. H. L. 1950. A case of bilateral testicular hypoplasia in the goat. *Vet. Rec.*, **62**, 303.

- ROLSHOVEN, E. 1945. Spermatogenese und Sertoli-Syncytium. *Allg. Zellforsch. mikroskop. anat.*, **33**, 439.
- ROLSHOVEN, E. 1947. Über Resorptionsleistungen des Sertoli-Syncytiums in den Hodenkanälchen. *Anat. Anz.*, **96**, 220.
- ROLSHOVEN, E. 1951. Über die Reifungsteilungen bei der Spermatogenese mit einer Kritik des bisherigen Begriffes der Zellteilungen. *Anat. ges. Verhandl.*, **49**, 189.
- ROOSEN-RUNGE, E. C. 1951. Quantitative studies on spermatogenesis in the albino rat. II. The duration of spermatogenesis and some effects of colchicine. *Am. J. Anat.*, **88**, 163.
- ROOSEN-RUNGE, E. C. 1952a. Kinetics of spermatogenesis in mammals. *Ann. New York Acad. Sc.*, **55**, 574.
- ROOSEN-RUNGE, E. C. 1952b. The third maturation division in mammalian spermatogenesis (Abstr.). *Anat. Rec.*, **112**, 463.
- ROOSEN-RUNGE, E. C. 1953. Postmortem mitotic activity of spermatogonia and spermatocytes in the albino rat. *Exper. Cell Res.*, **4**, 52.
- ROOSEN-RUNGE, E. C. 1954a. Some data on the productivity of the seminiferous tubules of the rat (Abstr.). *Anat. Rec.*, **118**, 346.
- ROOSEN-RUNGE, E. C. 1954b. Proceedings First World Congress. *Fertil. & Steril.*, **3**, 107.
- ROOSEN-RUNGE, E. C. 1955a. Quantitative studies on spermatogenesis in the albino rat. III. Volume changes in the cells of the seminiferous tubules. *Anat. Rec.*, **123**, 385.
- ROOSEN-RUNGE, E. C. 1955b. Untersuchungen über die Degeneration samenbildender Zellen in der normalen Spermatogenese der Ratte. *Ztschr. Zellforsch. mikroskop. Anat.*, **41**, 221.
- ROOSEN-RUNGE, E. C. 1956. Quantitative investigations on human testicular biopsies. I. Normal testis. *Fertil. & Steril.*, **7**, 251.
- ROOSEN-RUNGE, E. C., AND BARLOW, F. D. 1953. Quantitative studies on human spermatogenesis. I. Spermatogonia. *Am. J. Anat.*, **93**, 143.
- ROOSEN-RUNGE, E. C., AND GIESEL, L. O., JR. 1950. Quantitative studies on spermatogenesis in the albino rat. *Am. J. Anat.*, **87**, 1.
- ROOSEN-RUNGE, E. C., MAMBERGER, E., AND NELSON, W. O. 1957. Quantitative investigations on human testicular biopsies. II. Infertility and other conditions. *Fertil. & Steril.*, **8**, 203.
- ROY, S. N., KAR, A. B., AND DATTA, S. N. 1955. The influence of testosterone propionate on the response of the testis of young rats to thyroxine. *Arch. internat. pharmacodyn.*, **102**, 150.
- RUBIN, D. 1911. The question of an aqueous hormone from the testicle. *Endocrinology*, **29**, 281.
- RUBINSTEIN, H. S., AND ABRAMNEX, A. 1939. The influence of the water-soluble gonadotrophic factor of pregnancy urine on the testes of the normal immature and mature rat. *J. Lab. & Clin. Med.*, **24**, 799.
- RUBINSTEIN, H. S., AND KURLAND, A. A. 1911. The effect of small doses of testosterone propionate on the testis and accessory sex organs. *J. Urol.*, **45**, 780.
- RUZICKA, L., AND PRELOG, V. 1943. Untersuchungen von Extrakten aus Testes: sur Kenntniss der Lipode aus Schweinetestes. *Helvet. chim. acta*, **26**, 975.
- SARGENT, J. W., AND McDONALD, J. R. 1948. A method for the quantitative estimate of Leydig cells in the human testis. *Proc. Staff Meet.*, *Mayo Clin.*, **23**, 249.
- SAVARD, K., DOREMAN, R. I., AND POUTASSE, E. 1952. Biogenesis of androgens in the human testis (Abstr.). *J. Clin. Endocrinol.*, **12**, 935.
- SAVARD, K., BESCH, P. K., RESTIVO, S., AND GOLDZIEHER, J. W. 1958. Biosynthesis of steroids in stallion testis tissue. *Fed. Proc.*, **17**, 303.
- SAVARD, K., DOREMAN, R. I., BAGGETT, B., AND ENGEL, L. L. 1956. Biosynthesis of androgens from progesterone by human testicular tissue *in vitro*. *J. Clin. Endocrinol.*, **16**, 1629.
- SAYLES, E. D. 1939. Postnatal development of reproductive system in male guinea pigs and its relation to testis hormone secretion. *Physiol. Zool.*, **12**, 256.
- SCHLOTTHAUER, C. F., AND BOLLMAN, J. L. 1942. The effect of artificial cryptorchidism on the prostate gland of dogs. *Am. J. Vet. Res.*, **3**, 202.
- SCHONFELD, W. A. 1943. Primary and secondary sexual characteristics: study of their development in males from birth through maturity, with biometric study of penis and testes. *Am. J. Dis. Child.*, **65**, 535.
- SCHULTZ, A. H. 1938. The relative weight of the testes in primates. *Anat. Rec.*, **72**, 387.
- SCHÜTZ, W. 1952. Histologische Befunde am menschlichen Hoden nach Hormonbehandlung des Prostatacarcinoms. *Arch. klin. Chir.*, **271**, 65.
- SCHWARTZ, M. 1945. Effect of stilbestrol on testis and breast of patients treated for carcinoma of prostate gland. *Proc. Am. Fed. Clin. Res.*, **2**, 97.
- SCOTT, M. G., AND SCOTT, P. P. 1957. Postnatal development of the testis and epididymis in the cat. *J. Physiol.*, **136**, 40P.
- SCOW, R. O., AND MARX, W. 1945. Response to pituitary growth hormone of rats thyroidectomized on the day of birth. *Anat. Rec.*, **91**, 227.
- SCOW, R. O., AND SIMPSON, M. E. 1945. Thyroidectomy in the newborn rat. *Anat. Rec.*, **91**, 209.
- SCULLY, R. E., AND COFFIN, D. L. 1952. Canine testicular tumors with special reference to their histogenesis, comparative morphology, and endocrinology. *Cancer*, **5**, 592.
- SELYE, H. 1943. Production of testis atrophy by steroids. *Endocrinology*, **32**, 116.
- SELYE, H., AND ALBERT, S. 1942a. Prevention by certain steroids of testicular atrophy usually elicited by small doses of testosterone. *Proc. Soc. Exper. Biol. & Med.*, **49**, 227.
- SELYE, H., AND ALBERT, S. 1942b. Morphogenetic actions of various steroids in the castrate male rat. *J. Pharmacol. & Exper. Therap.*, **76**, 137.
- SHAY, H., GERSHON-COHEN, J., PASCHKIS, K. E., AND FELS, S. S. 1941. Inhibition and stimulation of testes in rats treated with testosterone propionate. *Endocrinology*, **28**, 485.

- SHETTLES, L. B., AND JONES, G. E. S. 1942. The effect of thyroidectomy on spermatogenesis in the adult male guinea pig (Abstr.). *Anat. Rec.*, **84**, 531.
- SHIMKIN, M. B., GRADY, H. G., AND ANDERVONT, H. B. 1941. Induction of testicular tumors and other effects of stilbestrol-cholesterol pellets in strain C mice. *J. Nat. Cancer Inst.*, **2**, 65.
- SIMONNET, H., AND STERNBERG, J. 1951. Le rôle endocrinien de l'épiphyse. I. L'épiphyse et le métabolisme du phosphore. *Rev. canad. biol.*, **9**, 407.
- SIMONNET, H., AND THIEBLLOT, L. 1951. Recherches expérimentales sur la physiologie de la glande pinéale. *Acta endocrinol.*, **7**, 306.
- SIMPSON, M. E., LI, C. H., AND EVANS, H. M. 1942. Biological properties of pituitary interstitial cell-stimulating hormone (ICSH). *Endocrinology*, **30**, 969.
- SIMPSON, M. E., AND EVANS, H. M. 1946a. Sensitivity of the reproductive system of hypophysectomized 40-day-old male rats to testosterone propionate (Abstr.). *J. Clin. Endocrinol.*, **6**, 474.
- SIMPSON, M. E., AND EVANS, H. M. 1946b. Comparison of the spermatogenic and androgenic properties of testosterone propionate with those of pituitary ICSH in hypophysectomized 40-day-old male rats. *Endocrinology*, **39**, 281.
- SIMPSON, M. E., LI, C. H., AND EVANS, H. M. 1944. Sensitivity of the reproductive system of hypophysectomized 40-day-old male rats to gonadotrophic substances. *Endocrinology*, **35**, 96.
- SIMPSON, M. E., AND VAN WAGENEN, G. 1954. Persistent nodules in testis of the monkey associated with Leydig cell hyperplasia induced by gonadotrophins. *Cancer Res.*, **14**, 289.
- SLYE, M., HOLMES, H. F., AND WELLS, H. G. 1919. Primary spontaneous tumors of the testicle and seminal vesicle in mice and other animals. XII. Studies in the incidence and inheritability of spontaneous tumors in mice. *J. Cancer Res.*, **4**, 207.
- SMELSER, G. K. 1939a. The effect of thyroidectomy on the reproductive system of hypophysis of the adult male rat. *Anat. Rec.*, **74**, 7.
- SMELSER, G. K. 1939b. Testicular function and the action of gonadotrophic and male hormones in hyperthyroid male rats. *Anat. Rec.*, **73**, 273.
- SMITH, H. A. 1954. Interstitial cell tumor of the equine testis. *Am. Vet. M. A. J.*, **124**, 356.
- SMITH, P. E. 1938. Comparative effects of hypophysectomy and therapy on the testes of monkeys and rats. In *Les hormones sexuelles*, *Foundation Singer-Polignac Colloquium*, L. Bronha, Ed., vol. 3, p. 201. Paris: Herman.
- SMITH, P. E. 1939. The effect on the gonads of the ablation and implantation of the hypophysis and the potency of the hypophysis under various conditions. In *Sex and Internal Secretions*, 2nd ed., E. Allen, C. H. Danforth and E. A. Doisy, Eds., p. 931. Baltimore: The Williams & Wilkins Company.
- SMITH, P. E. 1942. Effect of equine gonadotrophin on testes of hypophysectomized monkeys. *Endocrinology*, **31**, 1.
- SMITH, P. E. 1944. Maintenance and restoration of spermatogenesis in hypophysectomized rhesus monkeys by androgen administration. *Yale J. Biol. & Med.*, **17**, 281.
- SNAIR, D. W., JAFFRAY, S. E., GRICE, H. C., AND PUGSLEY, L. I. 1954. Studies on the subacute and chronic administration of stilbestrol in the male rat. *Canad. J. Biochem. & Physiol.*, **32**, 41.
- SNIFFEN, R. C. 1952. Histology of the normal and abnormal testis at puberty. *Ann. New York Acad. Sc.*, **55**, 609.
- SOHVAL, A. R. 1954. Histopathology of cryptorchidism; a study based upon the comparative histology of retained and scrotal testes from birth to maturity. *Am. J. Med.*, **16**, 346.
- SOTIRIADOU, E. 1941. Gonad stimulants in immature hypophysectomized male rats. *Acta brev. neerl. Physiol.*, **11**, 1.
- SOULAIRAC, A., SOULAIRAC, M.-L., AND TEYSSEYRE, J. 1955. Action de la corticostimuline hypophysaire, de la cortisone et de la désoxycorticostérone sur le testicule et le canal déférent du rat normal adulte. *Ann. endocrinol.*, **16**, 229.
- SREBE, P. A., CHAIKOFF, I. L., TREITMAN, S. S., AND BURSTEIN, L. S. 1950. The extrahepatic synthesis of cholesterol. *J. Biol. Chem.*, **182**, 629.
- STARKEY, W. F., AND LEATHAM, J. H. 1939. Action of estrone on sexual organs of immature male cats. *Anat. Rec.*, **75**, 85.
- STEIN, H. J., BADER, R. A., ELIOT, J. W., AND BASS, D. E. 1949. Hormonal alterations in men exposed to heat and cold stress. *J. Clin. Endocrinol.*, **9**, 529.
- STEINER, P. E., RASMUSSEN, T. B., AND FISHER, L. E. 1955. Neuropathy, cardiopathy, hemosiderosis, and testicular atrophy in *Gorilla gorilla*. *A. M. A. Arch. Path.*, **59**, 5.
- STEMMERMANN, G. N., WEISS, L., AUERBACH, O., AND FRIEDMAN, M. 1950. A study of the germinal epithelium in male paraplegics. *Am. J. Clin. Path.*, **20**, 21.
- TAGMANN, E., PIRELOG, V., AND RUZICKA, L. 1946. Untersuchungen über Organextrakte: Isolierung von Testosteron aus Testes des Pferdes. *Helvet. chim. acta*, **29**, 410.
- TALBOT, H. S. 1955. The sexual function in paraplegia. *J. Urol.*, **73**, 91.
- TELLUM, G. 1953. Classification and interpretation of testicular tumours. *Acta Univ. internat. contra cancerum*, **9**, 872.
- TELLUM, G. 1956. The sources of testicular androgen and estrogen. *Acta med. leg. et sociol.*, **9**, 305.
- TELLUM, G. 1950. Estrogen production by Sertoli cells in the etiology of benign senile hypertrophy of the human prostate; testicular lipid cell ratio and estrogen-androgen quotient in human male. *Acta endocrinol.*, **4**, 43.
- TILLINGER, K. G., BIRKE, G., FRANKSCON, C., AND PLANTIN, L.-O. 1955. The steroid production of the testicles and its relation to number and morphology of Leydig cells. *Acta endocrinol.*, **19**, 340.
- TOSUTTI, E. 1954. Action de la gonadotrophine chorionique sur les éléments testiculaires au

- point de vue qualitatif et quantitatif. Semaine méd. Paris, **30**, 2135.
- TOURNEY, G., NELSON, W. O., AND GOTTLIEB, J. S. 1953. Morphology of the testes in schizophrenia. A. M. A. Arch. Neurol. & Psychiat., **70**, 240.
- TUCHMANN-DUPLESSIS, H., AND MERCIER-PAROT, L. 1952. Action de l'acide 1 méthyl-bis-déhydro-diosynolique sur le système endocriné et la repousse des poils du rat. Compt. rend. Soc. biol., **146**, 919.
- TWOMBLY, G. H., MEISEL, D., AND STOUT, A. P. 1949. Leydig-cell tumors induced experimentally in the rat. Cancer, **2**, 884.
- VAN CAMPENHOUT, E. 1947. Les cellules sympathotropes de berges. Acta anat., **4**, 73.
- VAN CAMPENHOUT, E. 1949a. Les cellules sympathotropes du testicule du chien et du porc. Compt. rend. Soc. biol., **143**, 716.
- VAN CAMPENHOUT, E. 1949b. Les relations nerveuses de la glande interstitielle des glandes génitales chez les mammifères. Rev. canad. biol., **3**, 374.
- VAN WAGENEN, G., AND SIMPSON, M. E. 1954. Testicular development in the rhesus monkey. Anat. Rec., **118**, 231.
- VENNING, E. H. 1942. Étude hormonale sur un cas de tumeur interstitielle du testicule. Rev. canad. biol., **1**, 571.
- VIDGOFF, B., HILL, R., VEHRS, H., AND KUBIN, R. 1939. Studies on the inhibitory hormone of the testes. II. Preparation and weight changes in the sex organs of the adult, male, white rat. Endocrinology, **25**, 391.
- VIDGOFF, B., VEHRS, H. 1941. Studies on the inhibitory hormone of the testes. Endocrinology, **26**, 656.
- VILAR, O., AND HERTZ, R. 1958. Postnatal histogenesis and endocrine function of abnormal testes in the A x C rat. Proc. Soc. Exper. Biol. & Med., **98**, 553.
- WALLACE, C. 1949. The effects of castration and stilbestrol treatment on the semen production of the bore. J. Endocrinol., **6**, 205.
- WALSH, E. L., CUYLER, W. K., AND McCULLAGH, D. R. 1934. The physiologic maintenance of the male sex glands: the effect of androfin on hypophysectomized rats. Am. J. Physiol., **107**, 508.
- WATSON, M. L. 1952. Spermatogenesis in the albino rat as revealed by electron microscopy: a preliminary report. Biochim. et biophys. acta, **8**, 369.
- WEBSTER, R. C., AND YOUNG, W. C. 1951. Adolescent sterility in the male guinea pig. Fertil. & Steril., **2**, 175.
- WILDENMANN, W. 1952. Auswirkungen der lumbalen Sympathektomie auf den Gesamtorganismus, besonders auf Hoden und Nebenhoden. Zentralbl. Chir., **77**, 1385.
- WELLER, O. 1954. Über die Wirkung des Choriongonadotropins bei gesunden Männern. Arzneimittel-Forsch., **8**, 117.
- WELLS, L. J. 1912. The response of the testis to androgens following hypophysectomy. Anat. Rec., **82**, 565.
- WELLS, L. J. 1943a. Effects of large doses of androgen on the testis in the ground squirrel, *Citellus tridecemlineatus*. Endocrinology, **32**, 455.
- WELLS, L. J. 1943b. Descent of testis: anatomic and hormonal considerations. Surgery, **14**, 436.
- WELLS, L. J. 1944. Hormones and descensus testicularum. Bull. Minnesota Med. Fdn., **4**, 50.
- WEST, C. D., HOLLANDER, V. P., KRITCHEVSKY, T. H., AND DOBRINER, K. 1952. The isolation and identification of testosterone,  $\Delta^4$ -androstenedione-3,17, and 7-ketocholesterol from spermatid vein blood (Abstr.). J. Clin. Endocrinol., **12**, 915.
- WILKINS, L., AND CARA, J. 1954. Further studies on the treatment of congenital adrenal hyperplasia with cortisone. V. Effects of cortisone therapy on testicular development. J. Clin. Endocrinol., **14**, 287.
- WILLIAMS, R. B., AND CARPENTER, H. M. 1957. Early lesions in dog testes due to microwaves. Appendix B, Naval Med. Research Inst., Bethesda, Md., Research Report, Project NM001 056.13.02, **15**, 127.
- WILLIAMS, R. G. 1950. Studies of living interstitial cells and pieces of seminiferous tubules in autogenous grafts of testis. Am. J. Anat., **86**, 343.
- WILLIAMS, W. L., AND CUNNINGHAM, B. 1940. Histologic changes in the rat testis following heat treatment. Yale J. Biol. & Med., **12**, 309.
- WILSON, J. G., AND WILSON, H. C. 1943. Reproductive capacity in adult male rats treated prepuberally with androgenic hormone. Endocrinology, **33**, 353.
- WINTER, C. A., SILBER, R. H., AND STOERK, H. C. 1950. Production of reversible hyperadrenocorticism in rats by prolonged administration of cortisone. Endocrinology, **47**, 60.
- WISLOCKI, G. B. 1949. Seasonal changes in the testes, epididymides and seminal vesicles of deer investigated by histochemical methods. Endocrinology, **44**, 167.
- WOTIZ, H. H., DAVIS, J. W., AND LEMON, H. M. 1955. Steroid biosynthesis by surviving testicular tumor tissue. J. Biol. Chem., **216**, 677.
- WYNDHAM, N. R. 1943. A morphologic study of testicular descent. J. Anat., **77**, 179.
- YAO, T. S., AND EATON, O. N. 1954. Postnatal growth and histologic development of reproductive organs in male goats. Am. J. Anat., **95**, 401.
- YOUNG, W. C. 1927. The influence of high temperature on the guinea-pig testis. Histologic changes and effects on reproduction. J. Exper. Zool., **49**, 459.
- YOUNG, W. C. 1933. Die Resorption in den Duettuli Efferentes der Maus und ihre Bedeutung für das Problem der Unterbindung im Hoden-Nebenhodensystem. Ztschr. Zellforsch. mikroskop. Anat., **17**, 729.
- YOUNG, W. C., RAYNER, B., PETERSON, R. R., AND BROWN, M. M. 1952a. The thyroid and reproductive performance in the adult male guinea pig. Endocrinology, **51**, 12.



- YOUNG, W. C., RAYNER, B., PETERSON, R. R., AND BROWN, M. M. 1952b. Reproductive performance in extremely hypothyroid male guinea pigs. *Endocrinology*, **51**, 344.
- ZÄHLER, H. 1947. Über die Wirkung verschiedener Gaben von Testosteronpropionat auf infantilen Rattenhoden. *Arch. path. Anat.*, **314**, 23.
- ZÄHLER, H. 1950. Über die Wirkung eines hochgereinigten luteinisierenden Hormons auf den Rattenhoden. *Arch. path. Anat.*, **317**, 588.
- ZIDE, H. A. 1939. Does compensatory hypertrophy of the adult human testis occur? *J. Urol.*, **42**, 65.
- ZLOTNIK, I. 1943. A nuclear ring in the developing male germ cells of dog and cat. *Nature*, London, **151**, 670.
- ZUCKERMAN, S., AND McKEOWN, T. 1938. The canine prostate in relation to normal and abnormal testicular changes. *J. Path. & Bact.*, **46**, 7.

# 6

## THE ACCESSORY REPRODUCTIVE GLANDS OF MAMMALS

Dorothy Price, Ph.D.

PROFESSOR OF ZOOLOGY, THE UNIVERSITY OF CHICAGO

and

H. Guy Williams-Ashman, Ph.D.

ASSOCIATE PROFESSOR, BEN MAY LABORATORY, THE UNIVERSITY OF CHICAGO

I. GROSS STRUCTURE, HOMOLOGIES, AND OCCURRENCE IN MAMMALIAN ORDERS	366
A. Introduction	366
B. General Characteristics	367
C. Survey of the Glands	368
1. Bulbo-urethral and bulbivestibular	368
2. Male and female prostate glands	369
3. Seminal vesicles	376
4. Ampullary glands	376
D. Evolutionary History of Accessory Reproductive Glands in Mammals	376
II. FUNCTION OF MALE ACCESSORY GLANDS	377
A. Introduction	377
B. Volumetric Studies of Secretion	378
1. Prostatic isolation operation	378
2. Prostatic translocation operation	380
C. Chemical Composition of the Glandular Secretions	380
D. Metabolism of the Prostate and Seminal Vesicle	394
E. Coagulation of Semen	396
III. STRUCTURE AND FUNCTION IN RELATION TO HORMONES	398
A. Introduction	398
B. Effects of Androgens	399
1. Testicular androgens	399
2. Adrenal androgens	423
3. Ovarian androgens	424
4. Progesterone	425
C. Effects of Estrogens	426
D. Hormonal Control of Spontaneous Prostatic Neoplasms	429
1. Benign growths	429
2. Prostatic cancer	430
E. Effects of Carcinogenic Aromatic Hydrocarbons	430
F. Effects of Nonsteroid Hormones	433
1. Prolactin (LTH)	433
2. Growth hormone (STH)	434
IV. REFERENCES	435

### I. Gross Structure, Homologies, and Occurrence in Mammalian Orders

#### A. INTRODUCTION

The genital system of male mammals consists of three component parts. These are: (1) *paired testes*, the primary sex organs in which spermatozoa are formed and androgenic hormones are secreted; (2) *accessory reproductive organs*, a continuous series of *ducts* in which spermatozoa are transported from the testes, stored in the tail of the epididymis, and finally carried to the exterior when ejaculation occurs, and various *glands*, the secretions of which provide the carrying medium for the spermatozoa at emission; (3) *external genitalia*, the penis or copulatory organ and, in most mammals, a scrotum in which the testes come to lie more or less permanently, or only periodically during the breeding season.

Many cells in the epithelial lining of the efferent, epididymal, and deferent parts of the duct system have secretory functions, but all male mammals develop discrete and specialized glands which are associated with specific regions of the reproductive tract and eject their secretions into it at seminal emission. The degree of development of these large, conspicuous glands is a unique characteristic of mammals.

The accessory reproductive glands can be grouped logically into those which arise

embryonically from the mesonephric or Wolffian duct (ductus deferens) *i.e.*, the ampullary glands (glandula vasis deferentis) and seminal vesicles or vesicular glands, and those deriving from the urogenital sinus or urethra, namely the prostate and bulbo-urethral or Cowper's glands (see chapter by Burns). The anatomic relationships established in the fetus are retained to a considerable degree postnatally so that the ampullary glands and seminal vesicles are associated with the ducti deferentes. However, in some mammals the seminal vesicles empty into the pelvic urethra close to the openings of the deferent ducts but separate from them; no ejaculatory ducts are present. The prostatic and bulbo-urethral glands are associated with the proximal and distal urethra, respectively. The secretion of the prostate is discharged, in most cases, through multiple ducts that join the prostatic urethra at the level of the colliculus seminalis. The ducts of the bulbo-urethral glands drain into the urethra in the region of the urethral bulb.

In addition to these accessory reproductive glands, there are small mucus-secreting glands (of Littré) opening into the urethra along its length, and preputial glands (which are modified sebaceous glands) emptying their secretion on the prepuce.

In many female mammals, homologues of the male prostate and bulbo-urethral glands develop in the fetus. These glands may regress prenatally, remain vestigial, or develop postnatally and become functionally active. These homologues are the female prostate glands (para-urethral glands of Skene) and the bulbovestibular (major vestibular or Bartholin's glands). In addition, there are urethral glands (minor vestibular) which are homologous with the male urethral glands of Littré, and female preputial or clitoridal glands corresponding to the male preputials. The major vestibular, when present, and the minor vestibular and clitoridal glands are functional in many mature females. In a few cases, well developed prostate glands which are actively secretory have been found in females of four mammalian orders.

## B. GENERAL CHARACTERISTICS

The male accessory reproductive glands of higher mammals have many characteristics in common. Typically, all possess (1) a secretory epithelium which is enormously increased in effective secretory area by villous infoldings, or by a compound tubulo-alveolar structure, (2) an underlying layer of connective tissue (the lamina propria) and (3) smooth muscle fibers. It is now well established that the secretory activity of the epithelial cells is normally under the control of testicular hormones. The secretions pass from the cells into the lumina of the glandular alveoli where they are usually stored until ejaculation.

The sensory innervation includes various types of sensory nerve endings in the connective tissue, and free nerve endings in the epithelium. The autonomic innervation is parasympathetic (nervi erigentes) and sympathetic (hypogastric nerve) from the pelvic plexus. If the plexus is resected or the sympathetic chain above is interrupted, there is no reflex ejection of the glandular secretions. When the hypogastric nerve is stimulated, peristaltic waves of contraction occur in the ductus deferens, and there is contraction in the seminal vesicles and prostate which partially empties the stored secretion from the lumina of these glands. Stimulation of the parasympathetic system or the administration of pilocarpine results in an increased output of prostatic secretion.

There are marked dissimilarities in gross structure, character of the epithelia, and the chemical nature of the secretions in the various glands—prostates, seminal vesicles, bulbo-urethral, and ampullary (Mann, 1954a). There are also differences in structure and function between homologous glands in related forms. The nomenclature that was applied to the glands in early descriptive studies was often based on anatomic relationships and gross morphologic structure in adults. This resulted in some confusion in classification, but most of the disputed points have been clarified and some of the homologues have been established by embryologic study. The extensive studies of Mann (1954a) show clearly that

TABLE 6.1  
*Occurrence of male accessory reproductive glands and their homologues in females<sup>a</sup>*

Order	Male <sup>b</sup>						Female <sup>c</sup>
	Bu	Pr	Sv	Am	Bv	Pr	
Monotremata	+	-?	-	-	+	-	
Marsupialia	+	+	-	-	+	-	
Insectivora	+	+	±	±	+	+	Erinaceus europaeus (Deanesly, 1934) Hemicentetes (Lehmann, 1938) Talpa europea (Godet, 1949) Coelura afro (Mathews, 1941) Taphozous sp. (Mathews, 1941) Nycterus luteola (Mathews, 1941) Cariaciderma cor (Mathews, 1941)
Chiroptera	+	+	±	±	+	±	
Primates	+	+	±	±	+	-	
Carnivora	±	+	-	±	±	-	
Perissodactyla	+	+	+	+	+	-	
Artiodactyla	+	+	+	±	+	-	
Hyracoidea	+	+	+	+			
Proboscidea	+	+	+	+			
Sirenia	-	+	+	-	-		
Cetacea	-	+	-	-	-		
Edentata	±	+	+	-			
Pholidota	-	+	+	-			
Rodentia	+	+	+	±	±	±	Arvicanthus cinereus (Rauther, 1909) Rattus norvegicus (Marx, 1931, 1932; Korenchevsky and Dennison, 1936; Korenchevsky, 1937; Witschi, Mahoney and Riley, 1938; Price, 1939; Mahoney, 1940, 1942; Mahoney and Witschi, 1947) Mastomys erythroleucus (Brambell and Davis, 1940) Apodemus sylvaticus (Raynaud, 1942, 1945) Microtus arvalis (Delost, 1953a, 1953b) Sylvilagus floridanus (Elschlepp, 1952)
Lagomorpha	+	+	±	+	+	±	

<sup>a</sup> Compiled from Oudemans, 1892; Engle, 1926a; Retief, 1949; Eckstein and Zuckerman, 1956 and others. + indicates the presence of a well developed functioning gland. - indicates either a small vestigial gland or the absence of any rudiment.

<sup>b</sup> Bulbo-urethral (Cowper's), prostatic, seminal vesicle and ampullary glands.

<sup>c</sup> Bulbovestibular (Bartholin's) and prostatic glands (para-urethral glands of Skene); genera and species refer only to those in which functioning female prostates have been reported in the listed references.

homologous organs do not necessarily have the same chemical functions.

Finally, there is variability among orders of mammals and families within orders, with respect to the accessory glands which are present (Table 6.1). The prostate is the only gland that is found almost universally.

### C. SURVEY OF THE GLANDS

#### 1. Bulbo-urethral and Bulbovestibular Glands

Bulbo-urethral (Cowper's). The bulbo-urethral glands are compound tubulo-alveolar glands resembling mucous glands in some respects. Their secretion is a viscid lubricant which is emptied into the bulbar

region of the pelvic urethra. There may be a single pair of glands as in the monotremes, primates, and rodents, or as many as three pairs (Fig. 6.1), as in some marsupials (Chase, 1939; Rubin, 1944). Their relative size, gross structure, and complexity vary widely. For example, they are small, compact, bean-shaped glands in man, relatively enormous, complicated glands in squirrels, and large, cylindrical glands in the boar.

Bulbo-urethral glands are notably lacking in Cetacea, Sirenia, and certain carnivores such as seals, walruses, sea lions, all mustelids, and the bear and dog (Oudemans, 1892; Engle, 1926a; Eckstein and Zuckerman, 1956). Oudemans made a point of the fact that they are not present in aquatic mam-

mals, but it is rather doubtful if their absence is related to an aquatic environment.

**BULBOVESTIBULAR (BARTHOLIN'S).** The bulbovestibular or major vestibular glands are also compound tubulo-alveolar glands which resemble their male homologues in structure and secrete a mucus-like substance. Their secretory function is under control of ovarian hormones and they involute when the ovaries are removed. They are widely distributed in the various orders of mammals although the information is fragmentary with respect to some groups. A single pair of glands is the general rule and they are usually much smaller than the bulbo-urethral. In the female opossum, the single pair of glands is homologous with the smallest of the three pairs of Cowper's glands. In the adult, they are well developed and filled with colloid (Rubin, 1944). In monotremes the ducts open at the base of the clitoris, in opossums into the urogenital sinus canal, and in hyenas (where they are well developed) into the urogenital canal close to the base of the clitoris (Eckstein and Zuckerman, 1956). In many other females the ducts open into the vestibule. In the adult human female, Bartholin's glands resemble Cowper's glands closely in histologic structure.

## 2. Male and Female Prostate Glands

**MALE PROSTATE.** The prostate is a compound tubulo-alveolar gland in which the gross structure is variable and may be (1) disseminate or diffuse, in which the glandular acini remain within the lamina propria around the urethra and do not penetrate the voluntary muscle of the urethra, (2) a type in which the gland forms a "body," sometimes lobed, outside the urethral muscle, or (3) a combination of both types. A disseminate prostate is found in some marsupials (Fig. 6.1) and edentates, and in sheep, goats, the hippopotamus, and the whale. The bull and boar prostates have a disseminate region as well as a discrete body of the gland. In mammals in which there is a glandular body, there may be a solid, compact prostate as in the dog and man, or several lobes as in rodents (Figs. 6.2 and 6.3), lagomorphs (Fig. 6.4), and insectivores.

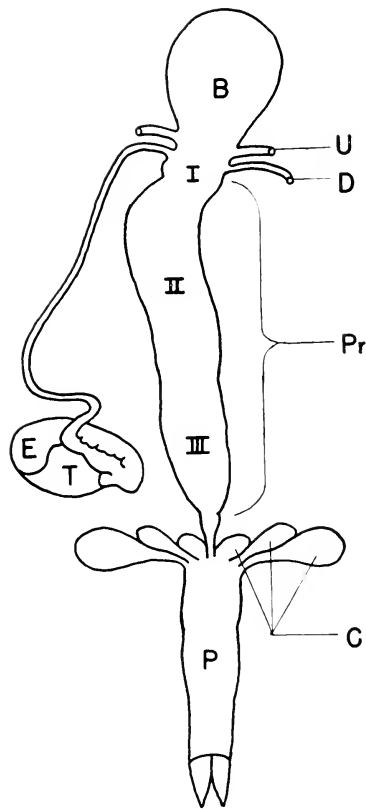

FIG. 6.1. Male opossum reproductive tract. *B*, bladder; *C*, Cowper's glands; *D*, ductus deferens; *E*, epididymis; *P*, penis; *Pr*, prostate I, II, III surrounding the urethra; *T*, Testis; *U*, ureter. (Redrawn from C. R. Moore, *Physiol. Zool.*, **14**, 1-15, 1941.)

A prostate gland has been found in all mammals that have been studied except monotremes, and is the only accessory gland in carnivores such as the ferret, weasel, dog, and bear, and in cetaceans—whales, dolphins, and porpoises. Oudemans (1892) considered that monotremes and marsupials lack prostate glands but possess well developed urethral glands. His classification of glands as "urethral" (glands of Littré) or "prostatic" depended on whether the glandular acini remained in the urethral stroma or penetrated the muscle to form

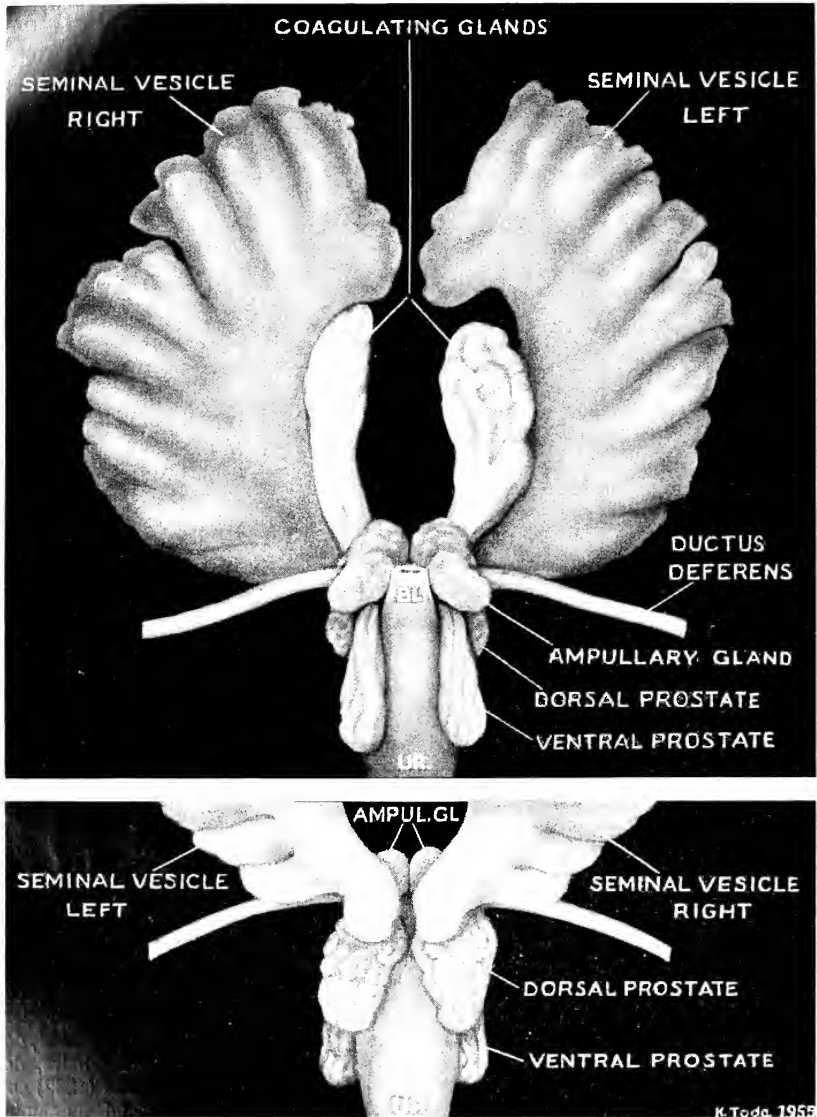

FIG. 62. Male hamster accessory reproductive glands. Above, ventral aspect; below, dorsal aspect.

body outside. It is now recognized that marsupials such as the opossum have a disseminate prostate, and in *Didelphys virginiana* there are three regions which differ

clearly in histologic structure (Chase, 1939). It may be considered that there are three prostatic "lobes" probably differing in function as well as in structure. Although Oule-

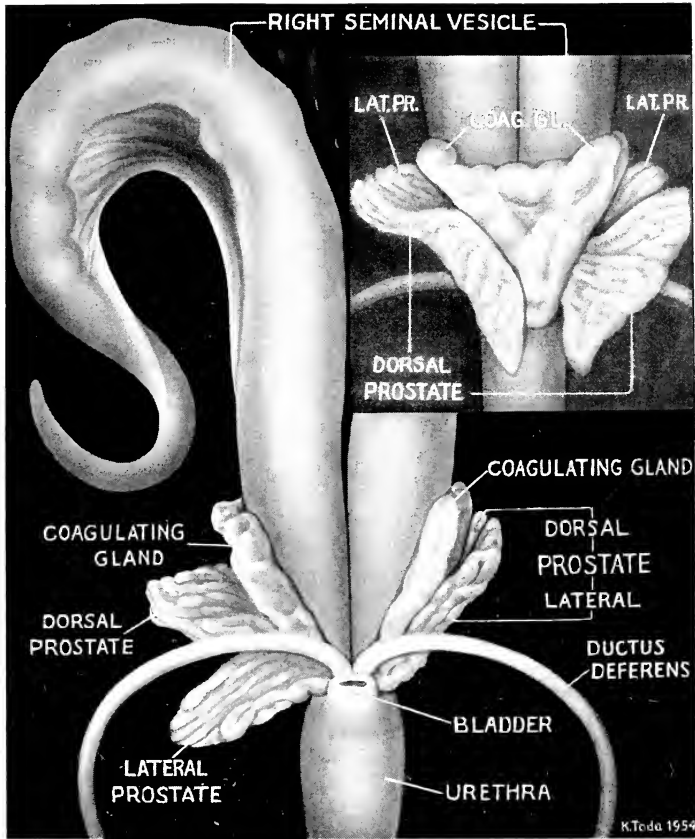

Fig. 6.3. Male guinea pig accessory reproductive glands. (From E. Ortiz, D. Price, H. G. Williams-Ashman and J. Banks, *Endocrinology*, 59, 479-492, 1956.)

mans concluded that monotremes lack prostate glands, he described a concentration of urethral glands at the neck of the bladder in the duckbill platypus, *Ornithorhynchus paradoxicus*. The diagrams in his monograph suggest that this concentration of complicated glands is a disseminate type of prostate.

There has been confusion in the nomenclature of the lobes of the prostate in the rat and in the descriptions of the structure of the lobes. In early studies the application of human anatomic terminology to rodents resulted in designation of the lobes as anterior (ventral), middle, and posterior (dorsal). Later terminology, more suitable for

quadrupedal animals, led to anterior (cranial), middle, and posterior (caudal). Unfortunately, combinations of these two systems of nomenclature still occur in the literature, and there is uncertainty as to the number of histologically distinguishable regions or lobes. In view of the current interest in the chemical composition of the glands and their secretions the subject will be reviewed.

For many years the prostate was usually described as being composed of three pairs of lobes: cranial or anterior (coagulating glands) bound to the seminal vesicles; middle or dorsolateral nearly encircling the urethra dorsolaterally, and the ventral or

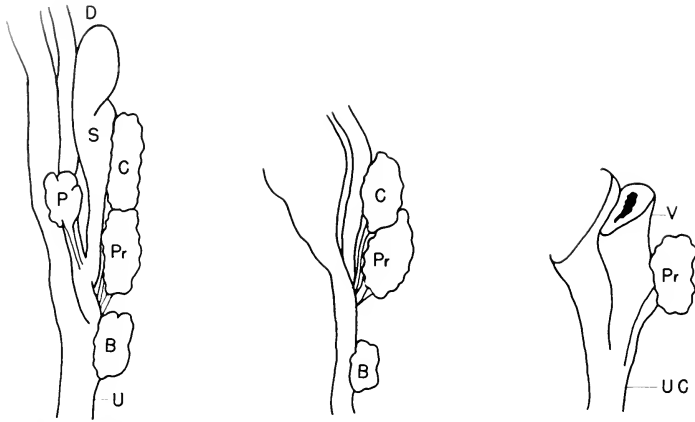

FIG. 6.4. Rabbit accessory reproductive glands; lateral aspect. Left, domestic male; center, cottontail male; right, cottontail female. *B*, bulbo-urethral gland; *C*, coagulating gland (vesicular gland); *D*, ductus deferens; *P*, paraprostate; *Pr*, prostate; *U*, urethra; *UC*, urogenital canal (vestibulum); *V*, vagina. (Redrawn from J. G. Elscliepp, *J. Morphol.*, **91**, 169-198, 1952.)

posterior (Moore, Price and Gallagher, 1930; Callow and Deaneley, 1935; Price, 1936). Korenchevsky and Dennison (1935) noted that the histologic structure of the dorsal lobe (or region) is quite similar to that of the coagulating glands whereas the lateral lobes more nearly resemble the ventral. This has been confirmed in histologic and functional studies (Price, Mann and Lutwak-Mann, 1955). Gunn and Gould (1957a) reported differences in histologic structure and functional activity in the two lobes.

The lateral lobes can be distinguished grossly from the dorsal by anatomic relationships and color, but the glandular lobules form a continuous mass and can be separated into distinct lateral and dorsal lobes only by dissection. This can be accomplished with considerable accuracy in immature males and young adults; in large rats it is more difficult because of distention of the alveoli and overlap of lobules in contiguous regions. The ventral tips of the lateral lobes extend down and partially underlie the ventral lobes to which they are loosely bound. The dorsal prostate is somewhat butterfly-shaped with a single cranial region and wings extending caudally along

the urethra much as in the hamster (Fig. 6.2). By dissection in the midline, it can be divided into right and left lobes. The dorsal and lateral prostates are drained by 50 or more ducts opening into the roof of the prostatic urethra (Witschi, Mahoney and Riley, 1938). Those from the dorsal region open more dorsally; those from the lateral lobes, laterodorsally.

Some of the confusion in prostatic terminology arises from the general application of the word "lobe" to (1) organs that are grossly anatomically distinct, (2) regions that do not form entirely discrete structures but can be distinguished histologically, (3) parts of the gland which contain two histologically different portions, and (4) regions that differ, not in histologic structure but in response to hormones and in the tendency to pathologic growths (human and dog).

The lobation of the human prostate has been the subject of controversy for some time. It is of especial interest because one region, the posterior or dorsal lobe, is commonly the site for prostatic carcinoma and another, the more anterior or ventral region, for benign prostatic hypertrophy. The lobes have been described as posterior, anterior, middle, and two lateral, or as posterior and



anterior, or outer and inner (medullary). The component parts of these regions have been discussed extensively (see Moore, 1936; Huggins and Webster, 1948; Retief, 1949; Franks, 1954). Lowsley (1912) studied the embryologic development of the human prostate and concluded that the gland derives from five independent groups of tubules. A cranial posterior or dorsal group (lobe) arises from the dorsal wall of the prostatic urethra or urogenital sinus; right and left lateral lobes originate from the prostatic furrows and grow back to form the main part of the base of the gland; a middle lobe derives dorsally from the urethra between the bladder and ejaculatory ducts; a ventral or anterior lobe forms but regresses and becomes insignificant.

Although these prostatic buds or tubules form independent groups in their embryonic origin there is no clear separation into such groups in the human prostate postnatally. However, Huggins and Webster (1948) were able to distinguish clearly two different regions, a posterior and an anterior lobe, by differential response to estrogen administration. The extent of the anterior or ventral lobe, as delimited by them, apparently includes the tubules of the middle and lateral lobes as described by Lowsley.

The pioneer studies of Walker (1910a) on the coagulating function of discrete glands of the prostatic complex in rats and guinea pigs (Fig. 6.3) were followed by specific identification of coagulating glands in several rodents including mice and hamsters (Fig. 6.2) and in the rhesus monkey (van Wagenen, 1936). However, a copulation plug in the vagina of females has been reported in some marsupials, insectivores, chiropterans, the chimpanzee among the primates (Tinklepaugh, 1930), and several genera of rodents in which coagulating glands have not been identified. Eadie (1948a) found that in an insectivore, *Condylura cristata*, there is a peculiar prostatic secretion from paired ventral lobes. It contains an enormous number of amyloid bodies resembling the corpora amyloacea present in the prostate gland of man and some other mammals. These prostatic concretions are generally considered abnormal, but Eadie suggested that this unusual se-

cretion, which was found in all breeding males, might be instrumental in the formation of a unique type of copulation plug. A large "urethral" gland which lies between the prostate and bulbo-urethral glands and surrounds the urethra is peculiar to certain species of bats. Mathews (1941) considered it probable that the presence of this gland is correlated with the formation of a large copulation plug, but he did not ascribe a specific coagulating function to the gland (which bears a histologic resemblance to the bulbo-urethral glands in some bats).

The difficulties of homology and classification can be illustrated by the case of the rabbit. Differences of opinion have existed concerning the nomenclature and homologies of the seminal vesicles (or prostatic utricle), vesicular glands (seminal vesicle or prostate), and paraprostate glands (or superior Cowper's glands). In studies on embryologic development and histologic structure, Bern and Krichesky (1943) clarified the problem. They established that the domestic rabbit has true seminal vesicles, vesicular glands (which are considered as probably homologous with the coagulating glands of rats), prostates, paraprostates (usually similar to the bulbo-urethrales in histologic structure but in about one-third of the cases, one or more of the paraprostates resembled the prostate histologically), bulbo-urethral glands, and glandular ampullae. Elsehepp (1952) compared the accessory glands of the cottontail, *Sylvilagus floridanus*, with those of the domestic rabbit, and concluded that coagulating glands (avoiding the usage of "vesicular glands" which has often been used synonymously with seminal vesicles), dorsal prostates, and bulbo-urethral glands are homologous in the two species. The adult cottontail has neither paraprostates nor seminal vesicles (Fig. 6.4). Classification of the glands in the hedgehog and shrew has also presented problems (see discussion in Eckstein and Zuckermann, 1956; Eadie, 1947). Among the Sciuridae, many possess a bulbar gland, which differs from their true Cowper's glands (Mossman, Lawlah and Bradford, 1932). It is evident that among mammals

there are many potentialities for forming accessory glands with varied anatomic structure, histologic characteristics, and functional activities.

**FEMALE PROSTATE.** In fetuses of many female mammals, small cords of cells which represent the homologues of the male prostate bud off from the epithelial lining of the urethra. These primordia normally retrogress or remain vestigial and only rarely continue to develop after birth. In the human female, these rudimentary structures are known as para-urethral glands of Skene. They have also been referred to as peri-urethral glands. However, it seems advisable, as Witschi, Mahoney and Riley (1938) suggested, to restrict the usage para-urethral and peri-urethral to the aggregations of mucus-secreting glands that have short ducts opening into the urethra. These clearly differ from the true female prostate glands.

In contrast to the rudimentary prostate glands which are retained postnatally by some female mammals, relatively large, well developed female prostates have been reported postnatally in some insectivores, chiropterans, rodents, and lagomorphs. The male accessory glands of many species in these orders are exceptionally well developed and the prostates are usually lobed. Female prostates are tubulo-alveolar glands, as are their male homologues, and they too form lobes, but the glands are never as large as those of the male. Their secretory activity is apparently dependent mainly on ovarian androgens, but the function, if any, of the secretion is obscure. Extensive research has shown that the administration of androgens to rodents, either to pregnant females or fetuses, to fetal lagomorphs, and to pouch-young opossums, results in the formation and retention of prostates in females which normally do not have such glands (see chapter by Burns).

Deanesly (1934) described vaginal glands in the female hedgehog and suggested that one pair is homologous with the external prostates of the male. The female glands extend dorsolaterally on either side of the urethra and a single duct from each lobe opens into the vagina. They seem to be active during the breeding season and to retrogress in the anestrus. In another insectivore,

*Hemicentetes*, there is a pair of large "paravaginal glands" which are functionally active in the mature female and have large acini filled with secretion. They resemble the male prostate in histologic structure and anatomic position, but have no ducts (Lehmann, 1938). In adult European moles, most females have bilobed ventral prostate glands which undergo cyclic changes in the epithelium. The prostate of the male is also bilobed and ventral in position and the homology in the two sexes is clear (Godet, 1949).

Mathews (1941) studied the anatomy and histophysiology of the male and female genital tracts of nine species of African bats. Female prostates are well developed in four species, less conspicuous in a fifth, and absent from the remaining four. There is a marked tendency for greater development of the glands in pregnant and lactating females. In three species, the female prostates surround the urethra (as do their male homologues), but in *Nycteris leucola* the female prostate appears ventrally, whereas the male prostate in this species is limited to the dorsal aspect of the urethra. Mathews considered that the female prostates represent greatly enlarged female urethral glands which are homologous with the male prostate.

The occurrence of female prostates and their relation to hormones have been most extensively studied in rodents. The first description of a well developed female prostate gland seems to be that of Rauther (1909), who found such a gland ventral to the neck of the bladder in the African field rat, *Arvicanthis cinereus*. In *Rattus norvegicus*, Marx (1931, 1932) reported the sporadic occurrence of female prostates. Korenchevsky and Dennison (1936) and Korenchevsky (1937) found prostates in 9 of 56 females and stated that the glands were atrophic, but when androgens were administered, these glands resembled the male ventral prostate. On this basis, the homology of the glands of the female with the ventral prostate of the male was suggested. Further studies (Witschi, Mahoney and Riley, 1938; Mahoney, 1940, 1942; Mahoney and Witschi, 1947) showed that the female prostate of the rat is homologous

with only the most medioventral part of the male prostate; the lobes are bilateral or unilateral, with the right the preferred side; each lobe has a single duct which opens into the urethra. The incidence of female prostates varies markedly in different strains, and can be increased by selective inbreeding, which also increases the occurrence of bilateral compared with unilateral lobes. The frequency of female prostates was increased in the Wistar stock from 28 to 99 per cent, but when selective inbreeding was stopped, the frequency declined.

In young untreated female rats, the prostate, when present, develops a histologic structure identical with that of the male homologue, but at about 6 weeks of age the epithelium undergoes regression (Price, 1939; Mahoney, 1940) and becomes histologically well developed again only during pregnancy and lactation (Burrill and Greene, 1942; Price, 1942). Thus, the female prostate of the rat is not only homologous with a part of the ventral prostate of the male on the basis of embryologic development, but during early postnatal development and in periods of pregnancy and lactation it resembles its male homologue histologically (Fig. 6.46). In addition, it is functionally equivalent (see Section II) to the male ventral prostate in the secretion of citric acid (Price, Mann and Lutwak-Mann, 1949).

Brambell and Davis (1940) found large, well developed prostate glands in every one of 104 female African mice, *Mastomys erythroleucus* Temm. These glands consist of paired lobes, each draining into the urethra by a single duct. They resemble the ventral prostate of the male in position, shape, and histologic structure. On the basis of this evidence it was concluded that the female glands are the homologues of the male ventral prostate. In some cases, the female prostates are nearly as large as their male homologues and are actively secretory. Brambell and Davis correlated hypertrophy and secretory activity with the luteal phase of the cycle and gestation.

Female prostate glands have also been described in the field mouse, *Apodemus sylvaticus sylvaticus*. Raynaud (1942, 1945) found bilobed prostates in 51 immature and

adult females collected in the vicinity of Vabre (Tarn) and in 3 females from three other regions of France. However, the lobes were macroscopically visible in only 10 females; in all others, the glands were identified in histologic preparations. There was great variability in histologic structure, but a well developed epithelium showing secretory activity was found during pregnancy and lactation. Raynaud established that the female prostate is homologous with a part of the male ventral prostate. He concluded that there is a probability that bilobed female prostates exist normally in all females of *Apodemus sylvaticus*.

The prostate glands in adult female field voles, *Microtus arvalis* P., are considered homologous with the ventral lobes and part of the lateral lobes of the male prostate (Delost, 1953a, b). The lobes in the female are lateral in position in part of the gland, but in other regions they completely surround the urethra. The structure is identical with that of the ventral prostate of the male. The epithelium appears secretory in normal adult females, and during gestation this activity is intense.

Bilobed female prostates were found in the 37 adult cottontail rabbits examined by Elschlepp (1952). They lie on the dorsal wall of the vagina (Fig. 6.4) and are similar histologically to the prostate of the male. The glands are larger in pregnant than in nonpregnant females and contain more secretion.

In summary, well developed female prostate glands are present in immature and adult females of many species. They may occur as ventral, lateral, or dorsal lobes; the lobes may be unilateral or consistently bilateral; their occurrence may be sporadic or reach an incidence of 100 per cent; they are found both in laboratory strains and in wild populations. The genetic studies of Witschi and his collaborators show that the incidence in rodents can be increased by selective inbreeding. In certain populations of wild rodents the character has become established. A striking example of this is the presence of large prostates in all female *Mastomys erythroleucus*. The secretory activity of the glands seems to be controlled mainly by ovarian androgens (see Section

III). No function can be ascribed to the secretion.

#### *Seminal Vesicles*

The seminal vesicles are paired, usually elongated glands which may appear relatively simple externally (Figs. 6.2 and 6.3) but are subdivided internally by complicated villous projections. The name refers to an old misconception that they are sperm reservoirs. The seminal vesicles are relatively enormous and distended with secretion in some mammals, for example, the rat, guinea pig, and hamster; they are large in others such as the boar, and in still others, as in man, they are small and compact.

Seminal vesicles are absent from the monotremes, marsupials, carnivores, and cetaceans that have been studied, and from some insectivores, chiropterans, primates, and lagomorphs. Variability exists among the edentates; the sloths and the armadillo have seminal vesicles which are well developed in the two-toed sloth and armadillo, but are very small and rudimentary in the three-toed sloth. Among the lagomorphs, the seminal vesicle of the domestic male rabbit is a large unpaired gland whereas the seminal vesicles in the adult cottontail rabbit are vestigial or absent although they develop for a time in the fetus (Elschlepp, 1952).

#### *4. Ampullary Glands*

These organs are glandular enlargements arising from the ampullae of the ducti deferentes or the posterior region of the ductus if a distinct ampullary enlargement is not present. They may be only slight glandular enlargements of the wall, or discrete glands which nearly encircle the ductus deferens as in rats, some mice, and hamsters (Fig. 6.2). They are vestigial in certain pure line strains of mice (Horning, 1947) and lacking in guinea pigs (Fig. 6.3). In some bats, they attain very large size. In general, they are absent from many mammalian orders and variable in others (Table 6.1).

#### D. EVOLUTIONARY HISTORY OF ACCESSORY REPRODUCTIVE GLANDS OF MAMMALS

The well developed male accessory glands which characterize the mammalian class as

a whole, and form such a conspicuous part of the reproductive tract in most mammals, are not found in nonmammalian vertebrates.

These glands appear as anatomically distinct organs in the primitive prototherian mammals, the monotremes, which are definitely mammalian but which also retain certain anatomic characteristics of their reptilian ancestors and still lay shelled eggs. However, it has been suggested that in the evolution of the three groups of living mammals from mammal-like reptiles, the line of descent of monotremes is entirely separate from that of marsupials and placentals. Furthermore, the last two groups are probably parallel branches of the mammalian stock.

The accessory glands of modern mammals represent, then, the parallel evolution of discrete glands that probably began their development very early in the evolutionary history of mammals. In gross structure, size, and internal complexity they are unique accessory organs among vertebrates. Modern reptiles have no such glands; the seminal plasma is composed mainly of secretions from the epididymis and the renal tubules of the sexual segment of the long, lobulated kidney. Both these regions become highly secretory during the breeding season (see chapter by Forbes). Parenthetically, the semen of birds (a later offshoot from the reptilian line than mammals) contains only a small amount of seminal plasma (Mann, 1954a) which is secreted in the cock almost entirely by the seminiferous tubules and vasa efferentia (Lake, 1957). In modern mammals, the epididymal epithelium is still an important accessory secretory area (see chapter by Bishop), but the bulk of the seminal plasma comes from glandular elaborations of quite different regions, the urogenital sinus (a derivative of the primitive cloaca) and the posterior part of the Wolffian ducts, the ducti deferentes.

Modern monotremes are specialized forms but in certain characteristics they are primitive. They show almost diagrammatically some of the first steps in the evolution of accessory glands. The bulbo-urethral are already well developed but the concentration of complicated urethral glands at the neck of the bladder in the duckbill platypus almost certainly illustrates the derivation

of a specialized gland (the prostate) from simpler glands which are numerous along the urethra. The probable evolution of prostates and bulbo-urethral glands from smaller, simpler urethral glands has been suggested in the past. Observations of Bruner and Witschi (1946) support this concept. In experiments on fetal hamsters, it was found that masculinized females developed prostate glands but the ducts joined the collecting ducts of the urethral glands and did not open directly into the urogenital sinus. According to these workers, this may represent an intermediate stage in the development of specialized glands.

The history of the cloaca may well be important in relation to development of accessory glands (Retief, 1949). The cloaca is retained in modern reptiles; in monotremes it is subdivided cranially into ventral urodeum or urogenital sinus and a dorsal coprodeum; it is represented by a pocket in marsupials but is lost as a discrete structure in all higher mammals. The first development of a separate urogenital duct or urethra as it occurs in monotremes may be correlated with the first appearance of discrete accessory glands from this specific region in mammals.

The marsupials illustrate a more advanced type of glandular development with three histologically distinguishable regions in the disseminate prostate and three pairs of bulbo-urethral glands. Seminal vesicles and ampullary glands are found only among higher mammals.

The size and structural complexity of these unique glands in mammals raises the question of the adaptive value of relatively large accessory glands associated with the mammalian reproductive tract. This is a matter only for speculation. The evolution of such glands with increased surface for secretion and enlarged storage space may, perhaps, have been correlated with a tendency for an increase in volume of seminal plasma in the ejaculate of mammals. Mann (1954a) pointed out the variability in the volume of ejaculated semen and in the sperm density in various species. With regard to the volume of seminal plasma, he stated, "In lower animals it may be so scarce that the emitted semen takes the

form of a very thick lump of spermatozoa, closely packed together. There is little seminal plasma in bird semen and even among some of the mammals, but on the whole, the higher mammals including man, produce a relatively dilute semen with a considerable proportion of seminal plasma." A second suggestion, more speculative, is that the evolution of large mammalian glands may also have compensated for loss of accessory reproductive function in the kidney. The kidney of mammal-like reptiles and ancestral mammals may have contributed to the formation of seminal plasma (as is true in modern reptiles, amphibians, and fishes), but the compact kidney of warm-blooded, metabolically active mammals may be ill adapted for such a purpose.

## II. Function of the Male Accessory Glands

### A. INTRODUCTION

The only known function of the male accessory glands is to secrete the seminal plasma. The proportion of this fluid which originates from the various secretory organs, or even from different lobes of the same gland, varies greatly from one species to another. There is also remarkable species variation in the volume and composition of the individual secretions. The functional activity of the accessory glands is governed primarily by hormones of testicular origin. The output of androgens is subject to the control of the anterior hypophysis, and many factors (*e.g.*, age, light, season, temperature, and diet) affect the secretory activity of the hypophysis and testis. Thus, it is not surprising that in a given individual, there may be marked fluctuations in the quantity and chemistry of the secretions of the accessory glands, and hence of the seminal plasma.

The development by Charles Huggins of ingenious surgical procedures enabled the secretory activity of the canine prostate to be measured by simple volumetric methods. Such studies of prostatic secretion in the dog established the quantitative relationships between the function of prostatic epithelium and the androgenic status of the host. In other species, serial collection of individual secretions in the same animal

has not been achieved for purely technical reasons. The use of "split ejaculates" has given some insight into the glandular origin of various components of the seminal plasma, but this technique does not provide uncontaminated secretions from any one gland. However, in the last two decades extensive analyses of the chemical and enzymatic constituents of the individual secretions stored in the accessory glands, and of the whole seminal plasma, have been performed. The levels of many of these substances and enzymes are dependent on androgenic hormones. These findings have provided a basis for sensitive chemical methods for the bioassay of androgens. Moreover, knowledge of the biosynthesis of these substances by the accessory glands may point to the primary biochemical locus of action of androgenic steroids. This chemical approach to the study of the accessory glands has received great impetus from the pioneer studies of Thaddeus Mann.

The secretions of the accessory glands of many species are a repository for huge quantities of substances which are present only in trace amounts in other tissues and body fluids. It is obvious that the seminal plasma must provide an ionically balanced and nutritive milieu suitable for the survival of sperm in the vagina and uterus. Certain substances secreted by one or more of the accessory glands, *e.g.*, fructose, undoubtedly serve as a source of energy for the sperm. However, there is no evidence that any component of mammalian seminal plasma, or any one of the accessory glands, is absolutely indispensable for fertility. Artificial insemination is successful in some mammals if sperm from the epididymis are diluted in a suitably prepared medium, placed in a female in the correct stage of the estrous cycle, and deposited in a region of the female tract where there is maximal opportunity for their successful ascent. Removal of the coagulating glands in guinea pigs (Engle, 1926b), or dorsolateral prostate (Gunn and Gould, 1958) in rats does not prevent insemination and fertilization. Blandau (1945) extirpated the seminal vesicles and coagulating glands of rats and found that when these males were mated there was no copulation plug and, evidently as a result, the spermatozoa did not penetrate the

vaginal canals of the females. Thus the secretions of the coagulating gland and seminal vesicles in the rat assist the transport of sperm in the female.

The following section will consider the output and composition of the secretions, and their hormonal regulation, primarily from a chemical standpoint, rather than in relation to the anatomy and embryology of the structures from which they originate.

## B. VOLUMETRIC STUDIES OF SECRETION

### 1. Prostatic Isolation Operation

Volumetric studies of the secretion of canine prostatic fluid have yielded great insight into the factors which determine the functional activity of male accessory glands. The dog is devoid of both seminal vesicles and bulbo-urethral glands, and if the urine is suitably deviated, practically pure prostatic secretion can be collected from the urethra. Eckhard (1863) ligated the neck of the bladder of dogs and obtained prostatic fluid by urethral catheterization. This technique was used by a number of investigators to study the secretory activity of the prostate gland (Mislawsky and Bornmann, 1899; Sergijewsky and Bachromejew, 1932; Winkler, 1931). A superior modification of the operation was introduced by Farrell (1931, 1938; Farrell and Lyman, 1937). The output of prostatic fluid was increased greatly either by electrical stimulation of the *nervus erigens* or by the injection of cholinergic drugs such as pilocarpine. These early prostatic isolation operations suffered from the signal disadvantage that, for technical reasons, they permitted only brief experiments.

In 1939, Huggins, Masina, Eichelberger and Wharton developed a simple surgical procedure which enabled frequent collection of canine prostatic secretion over long periods of time. The original technique was modified slightly by Huggins and Sommer (1953) and is depicted in Figure 6.5. The bladder is separated from the prostate gland, the urine voided through a suprapubic canula, and the animals circumcised. Healing was complete within one week after surgery, and the animals were maintained in good health. Prostatic fluid could be collected at frequent intervals for as long as

two years. Normal adult dogs were found to secrete 0.1 to 0.2 ml. of prostatic fluid per hour without external stimulation. Following the administration of pilocarpine, the canine prostate secreted as much as four times its weight of fluid (60 ml.) in one hour. The amount of secretion obtained in response to a standard dose of pilocarpine remained relatively constant for three months or more, and bore no direct relationship to the weight of the gland. The volume and composition of the fluid varied with the time and intensity of the cholinergic stimulus. Huggins (1947c) found that, after a single intravenous injection of pilocarpine, the volume and the content of total protein, certain enzymes (acid phosphatase,  $\beta$ -glucuronidase and fibrinogenase), and citrate were maximal in the first 15 minutes, then declined progressively in three succeeding quarter-hour periods. But the chloride content always rose initially from the low values of the resting secretion and reached maximal levels after the first 15-minute period. If the drug was administered intramuscularly, maximal values for total protein and citrate were found in the first period, whereas those for the volume and enzyme content were higher in the second and third periods. It was concluded from experiments involving the repeated intravenous injection of pilocarpine that acid phosphatase and fibrinogenase were definitely secreted and not simply washed out of the gland. However, a "washing out" process does occur after an initial stimulus with respect to total protein and citrate levels.

It was observed by Huggins, Masima, Eichelberger and Wharton (1939) that infectious diseases (*e.g.*, pyelonephritis, distemper) often decreased the volume of stimulated fluid. This effect seemed to be due to inhibition of the hypophysis, because it could be overcome by injection of gonadotrophin. Soon after castration (7 to 23 days) the secretion ceased and was restored by the administration of testosterone propionate. Androgens also initiated secretion in immature animals. In castrate dogs maintained on testosterone, neither adrenalectomy nor removal of the thyroid and parathyroid glands affected the rate of prostatic secretion. Huggins (1947c) observed that in normal

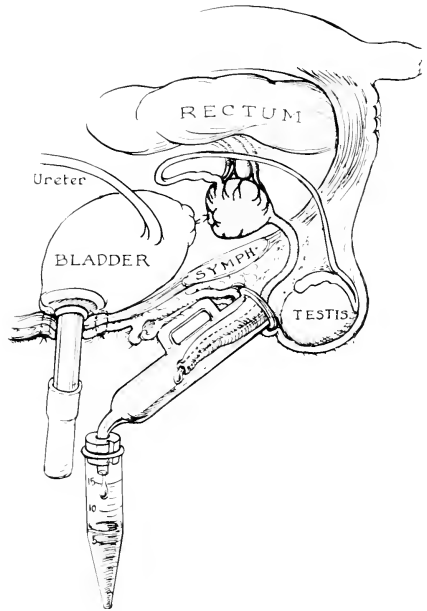

FIG. 65. The canine prostatic isolation operation. The connection of the prostatic urethra with the bladder has been severed and the prostatic secretion is collected by way of the penis. (From C. Huggins and J. L. Sommer, *J. Exper. Med.*, **97**, 663-680, 1953.)

animals, secretion was unaffected by injection of either progesterone or desoxycorticosterone.

Cystic hyperplasia of the prostate occurs in many senile dogs. The volume of fluid secreted by such hypertrophied glands in response to pilocarpine was smaller than that obtained from young adult animals (Huggins and Clark, 1940).

Injection of diethylstilbestrol into normal adult dogs abolishes prostatic secretion. Administration of gonadotrophin restores secretion in such estrogen treated animals, which suggests that the primary effect of estrogens under these conditions is on the hypophysis (Huggins, 1947c). Estrogens also antagonize the stimulatory effects of injected androgens. In castrate dogs receiving testosterone, injection of large doses of diethylstilbestrol decreases the output of prostatic fluid to very low levels (Huggins,

and Clark, 1940). The neutralization of androgen action by estrogens in this situation is pronounced but not complete. Thus the acid phosphatase activity of prostatic fluid collected from animals treated with both testosterone propionate and diethylstilbestrol is of the same order of magnitude as that of normal secretion, despite the fact that the volume of the secretion is extremely low (Huggins, 1947c). The ratio of diethylstilbestrol required to antagonize maximally the action of testosterone was found to be about 1:25. In dogs with either normal or cystic prostate glands, injection of amounts of estrogen sufficient to decrease prostatic secretion leads to shrinkage of the prostate. Large doses of estrogen cause the canine prostate gland to enlarge; the dorsal segment undergoes squamous metaplasia and the ventral lobe becomes atrophic (Huggins and Clark, 1940; Huggins, 1947c). If both estrogen and androgen are administered simultaneously, the dorsal region becomes squamous and the ventral portion of the gland retains its columnar epithelium, although the volume of the prostatic secretion may be drastically reduced.

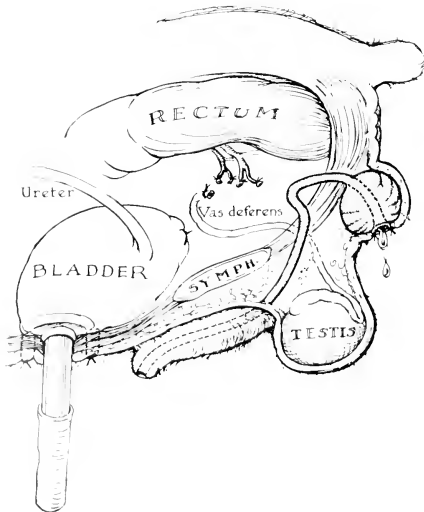

FIG. 6.6. The canine prostatic translocation operation. (From C. Huggins and J. L. Sommer, *J. Exper. Med.*, 97, 663-680, 1953.)

## 2. Prostatic Translocation Operation

Huggins and Sommer (1953) transposed the prostate gland of the dog from its natural position to the perineum, as depicted in Figure 6.6. This procedure permitted the size of the prostate to be measured in the living animal, and provided prostatic fluid quite uncontaminated with other material. Pilocarpine was used as a secretory stimulus. Using this technique, Huggins and Sommer found that the effects of androgens and estrogens on prostatic size and secretion were similar to those obtained with dogs that had undergone the prostatic isolation operation.

### C. CHEMICAL COMPOSITION OF THE GLANDULAR SECRETIONS

**ELECTROLYTES.** Water is the main constituent of prostatic and seminal vesicle secretions and of seminal plasma, all of which are approximately iso-osmotic with respect to blood serum. The vesicular secretion is usually more alkaline than the prostatic secretion and has a higher dry weight, mainly because it contains more protein. The electrolyte content of the secretions varies widely between different species (Huggins, 1945; Mann, 1954a). In general, sodium is the main cation, although this is not true of boar vesicular secretion which is very rich in potassium. Chloride tends to be the main anion in those species whose accessory gland secretions do not contain large amounts of citrate. In this connection it is instructive to compare the resting prostatic fluid of man, and the pilocarpine-stimulated prostatic fluid of the dog (Huggins, 1945, 1947c). The human secretion has a much greater citrate and calcium content, and a much smaller chloride level than the corresponding canine fluid, although the total concentration of osmotically active substances is of the same order of magnitude in both secretions.

**ZINC.** Bertrand and Vladesco (1921) found large amounts of zinc in human semen. The highest concentration of zinc is present in the first fraction of the ejaculate, which is largely prostatic secretion (Mawson and Fischer, 1953). In the rat, the zinc content of the dorsolateral prostate is especially high (Mawson and Fischer, 1951). After in-



tracardiac injection,  $Zn^{65}$  is concentrated by this tissue 15 to 25 times more than any other organ, including the ventral prostate (Gunn, Gould, Ginori and Morse, 1955). The dorsolateral prostate of the rat consists of two parts which are functionally and anatomically distinct, and only the lateral portion concentrates  $Zn^{65}$  (Gunn and Gould, 1956a, 1957a). A rapid uptake of  $Zn^{65}$  by slices of the rat dorsolateral prostate *in vitro* has been noted by Taylor (1957).

The zinc content of the rat dorsolateral prostate, and its uptake of  $Zn^{65}$ , are under hormonal control. The concentration of zinc in this gland increases 6- to 10-fold between the 35th and 100th day of life (Fischer, Tikala and Mawson, 1955). In the adult rat, Gunn and Gould (1956b) observed a marked decrease in  $Zn^{65}$  uptake after castration, which could be prevented by androgen treatment. In immature (Millar, Elcoate and Mawson, 1957) and hypophysectomized (Gunn and Gould, 1957b) animals, the administration of testosterone or gonadotrophin increased the zinc levels and the rate of  $Zn^{65}$  uptake, whereas estradiol was ineffective.

The physiologic function of the zinc in seminal plasma is problematical. This metal is an integral component of the enzyme carbonic anhydrase. The distribution of carbonic anhydrase among the various lobes of the prostate gland was studied by Mawson and Fischer (1952). In the rat, the posterior prostate contains about the same amount of carbonic anhydrase as the erythrocytes, whereas the ventral prostate contains very little of this enzyme. The lateral portion of the posterior prostate contains about 6 times as much zinc as the median part. But only a small portion of the zinc in the rat dorsolateral prostate, and in human semen, can be accounted for as carbonic anhydrase (Mawson and Fischer, 1953). According to Gunn and Gould (1958), dorsolateral prostatectomy, which removes most of the zinc from semen, is without influence upon either fecundity or fertility in the rat.

**FRUCTOSE.** The presence of a reducing and yeast-fermentable sugar in mammalian semen has been known for some time (McCarthy, Stepita, Johnston and Killian, 1928;

Huggins and Johnson, 1933). It was assumed by early workers that this sugar was glucose. Although Yamada (1933) reported that human semen contained a sugar which reacted as a ketose, it was not until 1945 that the nature of the main reducing sugar in most mammalian semens was elucidated by Thaddeus Mann. Using a highly specific enzymatic method of estimation, Mann (1946) showed that the semen of men and many other mammals contains little or no glucose. The reducing and yeast-fermentable sugar of bull seminal plasma was isolated in the pure state and identified as D(-)-fructose on the basis of its optical rotation and formation of methylphenyl fructosazone.

Mann (1949) found fructose in the semen of the bull, ram, boar, goat, opossum, rabbit, guinea pig, mouse, hamster, and man. It is also present in the European mole (*Talpa*) and hedgehog (*Erinaceus*) (Mann, 1956). Table 6.2 shows that the fructose content of semen varies greatly from one species to another. In the five species indicated, the total fructose accounts for all the yeast-fermentable carbohydrate present, but these species also contain non-fermentable sugars. The semen of some animals contains glucose. This is true of the rabbit, in which both glucose and fructose are detectable (Mann and Parsons, 1950), and the cock (Mann, 1954a), the semen of which is devoid of fructose. Ketoses other than fructose are found in certain semens. For example, the vesicular and ampullar secretions of the stallion possess carbohydrates which react in colorimetric tests as

TABLE 6.2  
*Reducing sugars of semen*

Values obtained from Mann (1946) and expressed in terms of milligrams of fructose per 100 ml. of semen.

Species	Total Reducing Sugar	Fructose	Yeast Fermentable Sugar	Nonfermentable Sugar
Bull	937	910	917	25
Ram	443	340	370	73
Rabbit	528	417	411	117
Man	295	141	144	149
Boar	31	9	10	21

\* Small amounts of glucose were occasionally found in rabbit semen by Mann and Parsons (1950).

ketoses, but cannot be fructose as they are not fermented by yeast (Mann, Leone and Polge, 1956).

In most mammals, fructose is formed mainly in the seminal vesicles (Huggins and Johnson, 1933; Davies and Mann, 1947; Mann, 1949; Ortiz, Price, Williams-Ashman and Banks, 1956). But in the rat, the seminal vesicles secrete little fructose, most of which originates from the dorsal prostate and coagulating glands (Humphrey and Mann, 1949).

Metabolic pathways for the biosynthesis of seminal fructose by the accessory glands have been studied extensively. From the results of experiments on diabetic animals, Mann and Parsons (1950) concluded that blood glucose was the precursor of seminal fructose. The hyperglycemia resulting from the administration of alloxan to rabbits was accompanied by a parallel increase in the fructose content of semen. Injection of insulin into such diabetic animals led to a fall in the levels of both blood glucose and seminal fructose. Similarly, the concentration of fructose in human semen was found to be abnormally high in diabetic patients. Mann and Lutwak-Mann (1951b) incubated minced accessory gland tissue with glucose and observed the formation of small amounts of fructose. Cell-free extracts of bull seminal vesicle showed marked phosphoglucosylase and phosphohexoisomerase activity. The same preparations hydrolyzed both glucose 6-phosphate and fructose 6-phosphate to the corresponding free sugars. Slices of seminal vesicle glycolyzed glucose at much greater rates than fructose. On the basis of these facts, Mann and Lutwak-Mann (1951a, b) postulated that the conversion of glucose to fructose involved an initial phosphorylation of glucose to glucose 6-phosphate by hexokinase, with adenosine triphosphate as the phosphate donor. After enzymatic isomerization of glucose 6-phosphate to fructose 6-phosphate, the latter was dephosphorylated to free fructose. It was assumed that any glucose formed by the dephosphorylation of glucose 6-phosphate was reutilized, whereas fructose was not, and hence accumulated in the secretion. This formulation is consonant with the properties of the hexokinase of seminal vesicle (Kellerman, 1955) which, at low sugar concentrations, phos-

phorylates glucose at much faster rates than fructose.

It was suggested by Mann and Lutwak-Mann (1951a, b) that the dephosphorylation of hexosemonophosphates by accessory glands was catalyzed by an alkaline phosphatase which attacked the 6-phosphate esters of both glucose and fructose. Kuhlman (1954) claimed, on histochemical evidence, that rat seminal vesicle contains a phosphatase specific for fructose 6-phosphate which is most active in the vicinity of pH 7. Kellerman (1955) stated that, although the microsome-bound alkaline phosphatase of guinea pig seminal vesicle hydrolyzes the 6-phosphate esters of glucose and fructose at approximately the same rate, the mitochondria of this tissue contain a phosphatase which, at pH 5.8, hydrolyzes fructose 6-phosphate ten times as rapidly as glucose 6-phosphate. However, Hers (1957a) was unable to confirm these observations.

An alternative pathway for the conversion of glucose to fructose was suggested by Williams-Ashman and Banks (1954a), who found that certain fructose-secreting accessory glands of rodents contain an enzyme, ketose reductase, which catalyzes the reversible oxidation of sorbitol to fructose. This enzyme attacks a number of higher polyols and uses diphosphopyridine nucleotide (DPN) as a specific hydrogen acceptor (Williams-Ashman, Banks and Wolfson, 1957). The presence of an active ketose reductase in male accessory sexual tissues was confirmed by Hers (1956, 1957a) who discovered another enzyme, aldose reductase, which catalyzes the reduction of glucose to sorbitol with dihydrotetraphosphopyridine nucleotide (TPNH) as the hydrogen donor. Hers suggested that seminal fructose was formed from glucose by the combined action of ketose and aldose reductases, as follows:

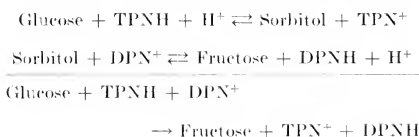

This mechanism for fructose biosynthesis accounts for the following observations (Hers, 1957a): (1) extracts of sheep seminal vesicle convert  $\text{C}^{14}$ -labeled glucose to fruc-

tose without rupture of the carbon chain; (2) TPNH and DPN are required for this transformation, during which sorbitol is produced, and becomes radioactive; (3) inhibitors of aldose reductase (*e.g.*, glucosone) inhibit the conversion of glucose to fructose and sorbitol; and (4) sorbitol is present, alongside fructose, in the secretions of sheep seminal vesicle and of certain accessory glands of other species (*vide infra*).

The relative importance of these phosphorylative and nonphosphorylative pathways for the biosynthesis of seminal fructose remains to be determined.<sup>1</sup>

The fructose content of semen and of the accessory glands is strictly controlled by testicular hormones. The experiments of Mann and Parsons (1950), depicted in Figure 6.7, show that in the sexually mature rabbit, seminal fructose levels fell dramatically soon after castration. This decrease in seminal fructose was prevented by implantation of a pellet of testosterone. Later administration of androgen to the orchidectomized animals restored seminal fructose to normal levels. Measurement of the fructose content of ejaculated semen may be a sensitive index of androgenic activity, and has the signal advantage that the time-sequence of changes which result from alterations in the level of circulating androgen can be determined without sacrifice of the animal. This "fructose test" has been used to assess the production of testicular androgen, or the hormonal activity of exogenous substances, in man (Harvey, 1948; Landau and Loughhead, 1951; Tyler, 1955; Nowakowski and Schirren, 1956; Nowakowski, 1957) and in other animals (Gassner, Hill and Sulzberger, 1952; Branton, D'Arensbourg and Johnston, 1952; Mann and Walton, 1953; Glover, 1956; Davies, Mann and Rowson, 1957).

The amounts of fructose in semen and in the accessory glands are not determined solely by androgenic hormones, as Mann (1954a, 1956) has emphasized. The relative size and storage capacity of the accessory

<sup>1</sup>Samuels, Harding and Mann (1960) measured the aldose and ketose reductase levels in the various accessory glands of the rat, and in the seminal vesicles of the sheep, bull, boar, and horse. They found that the level of fructose production could be correlated with the activity of the least of the two enzymes.

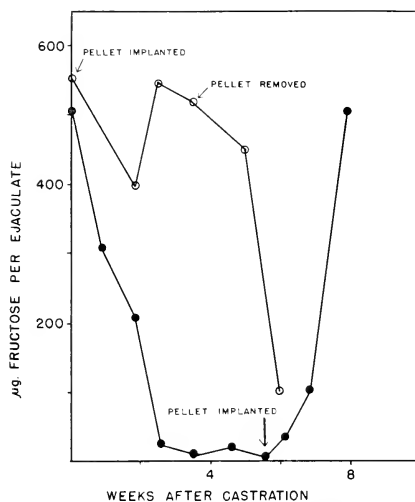

FIG. 6.7. Postcastrate fall and testosterone-induced rise of seminal fructose in the rabbit. The pellet contained 100 mg. of testosterone. (Redrawn from T. Mann, *The Biochemistry of Semen*, Methuen & Co., 1954.)

glands play an important role. Another factor which complicates the fructose test is frequency of ejaculation. In man and the stallion, a single ejaculation largely depletes the seminal vesicles (Mann, 1956). In the bull, however, the seminal vesicles have a remarkable storage capacity such that the fructose content of eight consecutive ejaculations obtained within one hour is practically the same (Mann, 1954a). Blood sugar levels can influence seminal fructose, but there is no evidence that the abnormally large quantities of fructose in diabetic semen (Mann and Parsons, 1950) result from increased output of androgenic hormones. Interruption of the blood supply to an accessory gland is another factor which affects the amount of fructose it secretes (Clegg, 1953). In immature animals, there seems to be a short time after birth when the accessory glands will not produce fructose in response to testosterone (Ortiz, Price, Williams-Ashman and Banks, 1956). Obstruction of the ejaculatory ducts will, of course, prevent the appearance of fructose in semen, as Young (1949) found in a patient with congenital unilateral aplasia of the vas deferens.

The anterior hypophysis may determine indirectly the secretory activity of accessory glands, and the amounts of fructose and other chemical substances which accumulate therein. Mann and Parsons (1950) showed that hypophysectomy in the rabbit results in a decline in the fructose content of semen, and of the prostate gland and glandula vesicularis. These changes were similar to those induced by castration, and could be reversed by treatment with androgens or with gonadotrophin. The deleterious effect of inanition, or a deficiency of certain B vitamins, on fructose formation in the accessory glands is almost certainly related to a concomitant depression of gonadotrophin secretion by the anterior pituitary gland (Lutwak-Mann and Mann, 1950). In the bull (Davies, Mann and Rowson, 1957), underfeeding leads to a greater depression of fructose levels in semen than of sperm formation.

Analysis of fructose in excised prostate gland or seminal vesicle has been used widely as an indicator of androgenic activity. This procedure has yielded much information concerning the relationship between the time of onset of androgen secretion by the testes and the initiation of spermatogenesis. In the rabbit (Davies and Mann, 1949), rat (Mann, Lutwak-Mann and Price, 1948), bull (Mann, Davies and Humphrey, 1949), boar (Mann, 1954b), and guinea pig (Ortiz, Price, Williams-Ashman and Banks, 1956), fructose can be detected in the accessory glands before spermatozoa are produced. The androgenic potency of exogenous substances can be determined by application of the fructose test to the accessory glands of animals castrated before or after puberty. The increase in fructose content of the coagulating gland of castrated rats in response to testosterone is greater than the corresponding change in organ weight (Mann and Parsons, 1950). The prostate gland and seminal vesicle of the rat (Rudolph and Samuels, 1949; Rudolph and Starnes, 1955; Rauscher and Schneider, 1954) and the seminal vesicle of the guinea pig (Levey and Szego, 1955b; Ortiz, Price, Williams-Ashman and Banks, 1956) behave in a similar fashion. This technique has provided evidence for the slight androgenic activity of progesterone (Price, Mann and Lutwak-Mann, 1955), and for the antagonistic (Parsons, 1950) or syn-

ergistic (Gassner, Hill and Sulzberger, 1952) influence of estrogens on the action of androgens.

Intact vascular and neural links are not necessary for the male accessory glands to accumulate fructose after androgenic stimulation. Subcutaneous transplants of these tissues into male rats will grow and produce fructose. After castration, the fructose content falls and can be restored by testosterone therapy (Mann, Lutwak-Mann and Price, 1948). Fructose secretion was also observed in accessory tissues transplanted into female hosts which had received androgens (Lutwak-Mann, Mann and Price, 1949), or were injected with gonadotrophins, which probably stimulate the secretion of ovarian androgens (Price, Mann and Lutwak-Mann, 1955).

The fructose in seminal plasma serves as a source of energy for spermatozoa under both anaerobic and aerobic conditions (Mann, 1954a).

**SORBITOL.** Sorbitol has been detected in the seminal vesicles of the sheep (Hers, 1957a, b) and the coagulating gland of the rat (Wolfson and Williams-Ashman, 1958), as well as in the semen of many species (King, Isherwood and Mann, 1958; King and Mann, 1958, 1959). The sorbitol content of semen tends to be high in those animals which exhibit high levels of seminal fructose, although it is also present in the semens of the stallion and cock, which are virtually devoid of fructose (Table 6.3). Sorbitol can be synthesized in the accessory glands by the action of either ketose reductase (Williams-Ashman and Banks, 1954a; Williams-Ashman, Banks and Wolfson, 1957; Hers, 1956, 1957a) or aldose reductase (Hers, 1956, 1957a). Under anaerobic conditions, spermatozoa will not glycolyze sorbitol (unlike fructose) to lactic acid, but will reduce both fructose and glucose to sorbitol. In oxygen, spermatozoa readily oxidize sorbitol (Mann and White, 1956), and also form sorbitol from glucose and fructose. The interconversion of fructose and sorbitol by spermatozoa is catalyzed by a DPN-specific ketose reductase (sorbitol dehydrogenase) which is similar to that of the accessory glands (King and Mann, 1959). Although the spermatozoa can affect the ratio of the levels of sorbitol and fructose in seminal plasma,

most of the seminal sorbitol is probably derived from the accessory glands.

**INOSITOL.** During his studies on the vesicular secretion of the boar, Mann (1954b) isolated large amounts of a crystalline, non-reducing carbohydrate which he identified rigorously as *meso*-inositol. This cyclic polyol was found only in the seminal vesicle, being absent from the epididymis and Cowper's gland. The concentration of inositol in boar vesicular secretion was as high as 2.6 gm. per 100 ml., and constituted as much as 70 per cent of the total dialyzable material therein. Using a specific microbiologic method of estimation, Hartree (1957) found that in the boar, the inositol content of seminal plasma was usually greater than 600 mg. per 100 ml., although much smaller quantities (less than 60 mg. per 100 ml.) were present in the bull, ram, stallion, and man. In all of the species examined, the bulk of the inositol in seminal plasma was in the free state, and in amounts much greater than those in blood or cerebrospinal fluid. In most animals, seminal inositol originates from the seminal vesicles, but it has been detected in the prostate gland of the hedgehog, and in the ampullar secretion of the stallion.

The levels of inositol in human semen, together with those of fructose, are increased after the administration of testosterone according to Kimmig and Schirren (1956).

The physiologic function, if any, of the inositol in seminal plasma is unknown. Since boar vesicular secretion, unlike other body fluids of the pig, contains immense amounts of inositol and very little sodium chloride, Mann (1954b) suggested that inositol is concerned with the maintenance of the osmotic equilibrium of boar seminal plasma.

**ASCORBIC ACID.** Deproteinized extracts of the seminal plasma of many species reduce 2,6-dichlorophenol indophenol in the cold. This property has been attributed to the presence of ascorbic acid in the semen of the bull (Phillips, Lardy, Heiser and Ruppel, 1940), guinea pig (Zimmet, 1939), and man (Nespor, 1939; Berg, Huggins and Hodges, 1941; Huggins, Scott and Heinen, 1942). However, it is now established that ascorbic acid does not always account for the total reducing power of semen. In some animals, *e.g.*, the boar, ergothioneine is responsible in

TABLE 6.3

*Sorbitol and fructose content of fresh seminal plasma*

In some cases the samples represented semen which had been pooled; the number of individuals is given in brackets. (From T. E. King and T. Mann, Proc. Roy. Soc. London, ser B, **151**, 226-243, 1959.)

Species	Number of Samples Analyzed	Sorbitol		Fructose	
		mg., 100 ml.		mg., 100 ml.	
Ram	5	26-120	(12)	150-600	(12)
Rabbit	1	80	(2)	40-150	(4)
Bull	4	10-136	(4)	120-540	(14)
Boar	4	6-18	(4)	20-40	(4)
Stallion	3	20-60	(3)	<1	(4)
Dog	2	<1	(3)	<1	(5)
Cock	3	10-15	(14)	<1	(14)
Man	1	10	(3)	154	(3)

large part for the reduction of indophenol (*vide infra*), and bull semen contains sulfite and another, unidentified, reducing substance (Larson and Salisbury, 1953). Nevertheless, ascorbic acid is undoubtedly present in seminal plasma. Employing a specific analytical method based on the formation of its dinitrophenylhydrazone, Mann (1954a) found that the seminal vesicle secretion of the rat, bull, guinea pig, and man contains ascorbic acid in amounts varying from 5 to 12 mg. per 100 ml. Mann's values for the ascorbic acid content of human semen (10 to 12 mg. per 100 ml.) agree well with those reported by Berg, Huggins and Hodges (1941), which were based on indophenol reduction.

**AMINO SUGARS.** After hydrolysis with acid, boar semen contains considerable amounts of amino sugars (Mann, 1954a). The epididymal "semen" contains more amino sugar than the vesicular secretion.

**ERGOTHIONEINE.** The vesicular secretion of the boar (Leone and Mann, 1951; Mann and Leone, 1953) is a rich source of ergothioneine. This sulfur-containing base is also found in the accessory glands of the European hedgehog and mole (Mann, 1956), and in the ampullar secretion of the stallion (Mann, Leone and Polge, 1956). Little or no ergothioneine is present in the semen of the bull, ram, and man.

Experiments with  $S^{35}$ -labeled precursors suggest strongly that seminal ergothioneine

is not synthesized in the animal body (Melville, Otken and Kovalenko, 1955; Heath, Rimington and Mann, 1957). Because orally ingested  $S^{35}$ -labeled ergothioneine passes into the seminal plasma of the boar (Heath, Rimington, Glover, Mann and Leone, 1953), it is possible that those accessory glands which secrete ergothioneine concentrate this substance from the blood.

Mann and Leone (1953) are of the opinion that the function of ergothioneine in seminal plasma is to protect the spermatozoa from the poisonous action of oxidizing agents. It is remarkable that the seminal fluids of the boar and the stallion, both of which contain ergothioneine, have common characteristics which would render their spermatozoa especially sensitive to oxidizing agents, *viz.*, large volume, low sperm density, and small content of glycolyzable sugars.

**POLYAMINES.** Large amounts of spermine and spermidine are present in the prostate gland of many species (Harrison, 1931; Rosenthal and Tabor, 1956). The chemical structure of these polyamines was elucidated by Dudley, Rosenheim and Starling (1926, 1927). Human seminal plasma contains as much as 300 mg. spermine per 100 ml., most of which is derived from the prostate gland. If human semen is allowed to stand for a few hours at room temperature, the spermine present crystallizes in the form of spermine phosphate ("Boettcher's crystals").<sup>2</sup> Both spermine and spermidine are oxidized by the diamine oxidase of human seminal plasma (Zeller, 1941; Zeller and Joël, 1941). These polyamines via their degradation products are highly toxic to spermatozoa (Tabor and Rosenthal, 1956), and it seems unlikely that

their presence in seminal plasma is of functional value.

**CHOLINE DERIVATIVES.** Florence (1895) described the formation of brown crystals upon the addition of a solution of iodine in potassium iodide to semen. This reaction was used as the basis of a medico-legal test for semen stains. Bocarius (1902) showed that choline was responsible for the formation of this material. In the rat, the seminal fluid is by far the richest source of choline of any tissue or body fluid (Fletscher, Best and Solandt, 1935). A series of careful studies by Kahane (Kahane and Levy, 1936; Kahane, 1937) revealed that human semen contains very little free choline immediately after ejaculation, but that large amounts of the free base are formed if the semen is allowed to stand at room temperature. Lundquist (1946, 1947a, b, 1949) isolated phosphorylcholine from human seminal plasma and showed that it was converted to choline and inorganic phosphate by seminal acid phosphatase. However, the French investigators (Diament, Kahane and Levy, 1952, 1953; Diament, 1954) isolated  $\alpha$ -glycerophosphorylcholine from the vesicular secretion of rats, and suggested that this substance, rather than phosphorylcholine, was the precursor of free choline in aged semen. Lundquist (1953) also found glycerophosphorylcholine in the vesicular secretion of the rabbit, rat, and guinea pig. Williams-Ashman and Banks (1956) showed that the amount of glycerophosphorylcholine in rat vesicular secretion falls rapidly after castration, and can be restored to normal levels by administration of testosterone. Režek and Sir (1956) found both phosphorylcholine and glycerophosphorylcholine in human ejaculates.

A thorough study of the water-soluble choline derivatives in seminal plasma was made by Dawson, Mann and White (1957). They found (Table 6.4) that in most species, glycerophosphorylcholine is the only derivative present, but in man there are considerable quantities of phosphorylcholine as well. The latter substance is rapidly dephosphorylated after ejaculation, but glycerophosphorylcholine is not degraded by enzymes in seminal plasma or vesicular secretion. In

<sup>2</sup>In a letter written to the Royal Society of London in November 1677, Antoni van Leeuwenhoek described for the first time the presence and movement of spermatozoa in human semen. In the same letter, he also mentioned that "three-sided bodies," which were "as bright and clear as if they had been crystals," were deposited in the aged semen of man. These crystals were undoubtedly composed of spermine phosphate. The history of the discovery of spermine in semen is admirably summarized by Mann (1954a), with special reference to the contributions of Louis Vanquelin (see footnote 3), and also of Alexander von Pöhl, whose claims for the therapeutic properties of spermine aroused much interest and controversy at the end of the 19th century.

TABLE 6.4  
*Phosphorylcholine and  $\alpha$ -glycerophosphorylcholine in semen and in secretions of accessory reproductive glands*

Species	Material	Concentration (mg. per 100 gm.) of:	
		Phosphorylcholine	$\alpha$ -Glycerophosphorylcholine
Ram	Semen	0	1185-1942
Ram	Seminal plasma	0	1601-2040
Bull	Semen	0	237-460
Bull	Seminal plasma	0	110-496
Bull	Vesicular secretion	Present	0
Bull	Epididymal secretion	0	1490
Bull	Ampullar secretion	0	94
Goat	Semen	0	1382-1550
Boar	Seminal plasma	0	108-235
Boar	Vesicular secretion	0	190
Boar	Epididymal secretion	0	3060
Stallion	Semen	0	38-113
Stallion	Ampullar secretion	0	120
Man	Semen	256-380	59-90
Rat	Vesicular secretion	0	654; 530-765 <sup>a</sup>
Rat	Seminal vesicle	—	190-515 <sup>a</sup>
Rabbit	Semen	0	215-370
Hedgehog	Secretion of "Prostate I and II"	Present	Present
Hedgehog	Secretion of "Prostate III"	Present	0
Monkey	Vesicular secretion	Present	0
Cock	Semen	Present	0

<sup>a</sup> Results from Williams-Ashman and Banks (1956); all other values from Dawson, Mann and White (1957).

the bull and boar, the epididymis is the principal source of the glycerophosphorylcholine of the seminal plasma.

Williams-Ashman and Banks (1956) provided evidence that the choline moiety of the glycerophosphorylcholine in vesicular secretion is not derived from a direct reaction between glycerol and cytidine diphosphate choline. The latter nucleotide was shown to be a precursor of lecithin in rat seminal vesicle tissue. The glycerophosphorylcholine of seminal plasma may originate from the enzymatic degradation of the choline-containing lipids of the seminal vesicle epithelium.

Choline and glycerophosphorylcholine are not metabolized by spermatozoa, and do not affect their respiration (Dawson, Mann and White, 1957). There is no evidence that the water-soluble choline derivatives of seminal plasma serve any useful function.

Lipids. That lipid-containing granules are present in human seminal plasma has been known for more than a century. They are found in prostatic secretion (Thompson,

1861), and were termed "lecithin-körnchen" by Fuerbringer (1881). However, Scott (1945) showed that lecithin is absent from both of these fluids, and that the majority of the phospholipid therein is phosphatidyl ethanolamine. Neutral fat is virtually absent from human seminal plasma and prostatic secretion, one-third of the total lipid of which can be accounted for as cholesterol.

According to Boguth (1952), about one-third of the total plasmalogen in bull semen (30 to 90 mg. per 100 ml.) is in the seminal plasma. In the ram, only 10 per cent of the seminal plasmalogen is found outside the spermatozoa (Hartree and Mann, 1959).

Large amounts of 7-dehydrocholesterol were found in the preputial gland and epididymis of the rat (Ward and Moore, 1953). One gram of the hydrocarbon heptacosane ( $\text{CH}_3(\text{CH}_2)_{25}\text{CH}_3$ ) was isolated from an alcoholic extract of 18 liters of human semen by Wagner-Jauregg (1941). The partition of heptacosane, and of steroidal estrogens (Diezfalussy, 1954) and androgens (Diezschel and Knöchel, 1950) between the spermatozoa

and plasma of human semen remains to be determined.

**CITRIC ACID.** Citric acid was first detected in human semen by Scherstén (1929). The distribution of citric acid in the semen and in the secretions of the accessory glands of various species is summarized in Table 6.5. In some animals, (*e.g.*, the rat and man), citric acid is produced mainly by the prostate gland, and in others (*e.g.*, the bull, boar, and guinea pig), most of it originates from the seminal vesicles.

The citric acid content of the seminal

plasma and of the secretions of accessory glands depends on androgenic hormones. Citric acid disappears from these fluids after castration, and is formed again after treatment with testosterone. This "citric acid test" has been used to determine the time of onset of secretory function in accessory glands (Mann, Davies and Humphrey, 1949; Ortiz, Price, Williams-Ashman and Banks, 1956), hormonal influences on secretion in subcutaneous transplants (Mann, Lutwak-Mann and Price, 1948; Lutwak-Mann, Mann and Price, 1949), the androgenic ac-

TABLE 6.5  
*Citric acid in semen and in the secretions of accessory reproductive glands*

Species	Material	Citric Acid (mg./100 gm.)	Reference
Man	Semen	140-637	Huggins and Neal (1942)
Man	Prostatic secretion	480-2688	Huggins and Neal (1942)
Man	Seminal vesicle secretion	15-22	Huggins and Neal (1942)
Man	Hypertrophic adenoma of the prostate gland	201-1533	Barron and Huggins (1946a)
Man	Carcinoma of the prostate gland	12-137	Barron and Huggins (1946a)
Bull.	Semen	510-1100	Humphrey and Mann (1949)
Bull.	Seminal gland secretion	670	Humphrey and Mann (1949)
Bull.	Ampullar semen	550	Humphrey and Mann (1949)
Bull.	Epididymal semen	0	Humphrey and Mann (1949)
Bull.	Epididymis	18	Humphrey and Mann (1949)
Boar	Semen	130	Humphrey and Mann (1949)
Boar	Cowper's gland secretion	0	Humphrey and Mann (1949)
Boar	Epididymal semen	0	Humphrey and Mann (1949)
Boar	Seminal vesicle secretion	580	Humphrey and Mann (1949)
Ram	Semen	110-260	Humphrey and Mann (1949)
Rabbit	Semen	110-550	Humphrey and Mann (1949)
Rabbit	Epididymis	54	Humphrey and Mann (1949)
Rabbit	Prostate (I, II and III)	62	Humphrey and Mann (1949)
Rabbit	Cowper's Gland	42	Humphrey and Mann (1949)
Rabbit	Ampulla	273	Humphrey and Mann (1949)
Rat	Seminal vesicle	39	Humphrey and Mann (1949)
Rat	Coagulating gland	0	Humphrey and Mann (1949)
Rat	Ampulla	0	Humphrey and Mann (1949)
Rat	Dorsolateral prostate	20	Humphrey and Mann (1949)
Rat	Ventral prostate	122	Humphrey and Mann (1949)
Stallion	Semen	8-53	Mann, Leone and Polge (1956)
Stallion	Seminal vesicle	77	Mann, Leone and Polge (1956)
Guinea pig	Seminal vesicle	153-216	Ortiz, Price, Williams-Ashman and Banks (1956)
Guinea pig	Seminal vesicle secretion	320-357	Ortiz, Price, Williams-Ashman and Banks (1956)
Guinea pig	Coagulating gland	26-40	Ortiz, Price, Williams-Ashman and Banks (1956)
Guinea pig	Lateral prostate	16-20	Ortiz, Price, Williams-Ashman and Banks (1956)
Guinea pig	Dorsal prostate	47-75	Ortiz, Price, Williams-Ashman and Banks (1956)
Dog	Prostatic secretion	0-30	Barron and Huggins (1946a)
Dog	Prostate gland	8	Barron and Huggins (1946a)
Jackass	Vesicular secretion	22-82	Mann, Leone and Polge (1956)



tivity of various hormones (Mann and Parsons, 1950; Price, Mann and Lutwak-Mann, 1955; Ortiz, Price, Williams-Ashman and Banks, 1956), and the effect of nutrition on the onset of androgen secretion and sperm formation in bull calves (Davies, Mann and Rowson, 1957).

The androgen-induced changes in the citrate levels in semen and various accessory glands are reminiscent of similar alterations in the fructose content of these tissues. However, the concentrations of these substances do not necessarily parallel one another in response to hormonal stimulation. In the post-estrade animal, the fall in citric acid and its reappearance after androgen treatment is usually more sluggish than that of fructose. Also, the seminal fructose of some species may not be secreted by the same accessory organ (or lobes of the gland) which produces citric acid. Thus in the rat, fructose is secreted by the anterior and dorsolateral prostate, whereas citric acid is derived from the seminal vesicles and dorsolateral and ventral prostates, but is totally absent from the anterior prostate (Humphrey and Mann, 1949). In the guinea pig, however, the seminal vesicles are the principal source of both fructose and citric acid (Ortiz, Price, Williams-Ashman and Banks, 1956).

Using a strain of rats in which the incidence of the female prostate is very high, Price, Mann and Lutwak-Mann (1949) showed that the growth of this gland which follows the injection of testosterone is accompanied by a tremendous increase in its content of citric acid. In this way the female prostate resembles the ventral prostate gland of the male rat.

Citric acid is synthesized in the prostate gland by the usual reactions of the tri-carboxylic acid cycle (Williams-Ashman, 1954; Williams-Ashman and Banks, 1954b). No other organic acids are present in more than trace amounts in the secretions of those accessory glands that accumulate citrate. The enzymatic machinery for the degradation of citric acid via the tri-carboxylic acid cycle is present in the rat ventral prostate gland (Williams-Ashman, 1954; Williams-Ashman and Banks, 1954b; Williams-Ashman, 1955) and there is no evidence, despite suggestions to the contrary (Awapara, 1952a), that cit-

ric acid accumulates because it cannot be oxidized. It has been suggested that a common denominator affecting the androgen-dependent accumulation of citric acid and fructose in the accessory glands is the intracellular balance between the oxidized and reduced forms of DPX and TPX (Talalay and Williams-Ashman, 1958).

Mann (1954a) has summarized the ideas of various authors concerning the possible functional role of citric acid in seminal plasma. All of these suggestions are based more upon conjecture than experimental fact.

**CATECHOLAMINES.** There is evidence for the presence of both epinephrine and norepinephrine in seminal plasma (Brochart, 1948; Beauvallet and Brochart, 1949). Extracts of human prostate and seminal vesicle contain a monoamine oxidase which oxidizes catecholamines (Zeller and Joël, 1941). Katsch (1959) detected serotonin and histamine in human ejaculates.

**AMINO ACIDS.** Chromatographic studies have revealed the presence of many free amino acids in human semen (Jacobsson, 1950; Lundquist, 1952), from which crystalline tyrosine was isolated by Wagner-Jauregg (1941). According to Barron and Huggins (1946b), human prostatic adenoma is very rich in free glutamic acid, and the nonprotein amino-nitrogen of this and dog prostatic tissue is high. Bovine seminal plasma contains free serine, alanine, glycine, and aspartic and glutamic acids (Gassner and Hopwood, 1952). A similar distribution of amino acids is found in the vesicular and ampullary secretions of the bull. The free amino acid levels of bull seminal plasma fall greatly after castration. In the rat, Marvin and Awapara (1949) found that the concentration of free amino acids in the whole prostate decreased markedly following orchidectomy, and could be restored to normal levels in the castrate animal by treatment with androgen. In this species, Awapara (1952a) observed that the content of free amino acids in the ventral lobe of the prostate was much higher than in the dorsal lobe. After castration, there was a marked drop in the content of most amino acids with the exception of aspartic and glutamic acids, which seem

to remain at almost normal levels (Awapara, 1952b).

Seminal plasma and the secretions of the male accessory glands contain a battery of proteolytic enzymes (*vide infra*). For this reason, changes in the levels of free amino acids in these fluids resulting from hormonal treatments should be interpreted with caution. Jacobsson (1950), for example, has shown that in human semen, the nonprotein nitrogen and amino-nitrogen content increases many fold within 60 minutes after ejaculation.

**PROSTAGLANDIN.** A vasodepressor substance, designated prostaglandin, was found by von Euler (1934, 1936) in the prostatic and vesicular secretions of man, and also in the accessory glands of sheep (von Euler, 1939). The prostaglandin of ram prostate was purified by Bergström (1949), who suggested that it was an unsaturated fatty acid devoid of nitrogen. According to Eliasson (1957), the prostaglandin of human semen and of the prostate gland of sheep are identical.

The pharmacologic effects which result from the injection of seminal plasma (*cf.* Kurzrok and Lieb, 1931; von Euler, 1934, 1936, 1939; Goldblatt, 1935; Cockrill, Miller and Kurzrok, 1935; Asplund, 1947) are complex, and are probably due to the combined action of many constituents of this fluid. The hypotensive action of protein fractions of the secretions of some accessory organs (Freund, Miles, Mill and Wilhelm, 1958) is discussed below.

**URIC ACID.** Bull seminal vesicles may contain as much as 70 mg. per cent of uric acid (Leone, 1953). The uric acid content of the semen of other animals is much lower (Mann, 1954a).

**UREA.** The urea content of human and ram semen is much higher than that found in the bull, boar, and stallion (Mann, 1954a).

**MAJOR PROTEIN CONSTITUENTS.** Human seminal plasma contains from 3.5 to 5.5 gm. of protein-like material per 100 ml. (Huggins, Scott and Heinen, 1942). Less than 18 per cent of this material is coagulable by heat, and as much as 68 per cent of it is dialyzable. Thus the majority of the seminal proteins of man can be classified as proteoses. Electrophoretic analyses

of the nondialyzable proteins of human seminal plasma have been performed by Gray and Huggins (1942) and by Ross, Moore and Miller (1942). The major components bore some correspondence to those of blood serum, although the amount of albumin was small. The proteins of bovine seminal plasma are less dialyzable, and more coagulable by heat, than those of man (Larson and Salisbury, 1954). Electrophoretic studies showed the presence of three major and eight minor constituents, which seemed to be distinct from the proteins of bovine blood serum. In this species glyco- or lipoproteins were present only in very low concentrations. Larson, Gray and Salisbury (1954) found that the bovine seminal plasma proteins are highly antigenic. They obtained immunologic evidence that the major protein constituents of this fluid are distinct from any of the main proteins of either blood or milk.

**ENZYMES.** (1) *Acid phosphatase.* Kutscher and Wolbergs (1935) discovered that human semen and prostate contain a very active phosphatase which is optimally active at pH 5 to 6. This enzyme is responsible for the greater phosphatase activity of male as compared with female urine. Its secretion by the prostate accounts for the fact that male urine collected from the renal pelvis exhibits very little enzyme activity (Scott and Huggins, 1942). Human prostatic acid phosphatase hydrolyzes a number of phosphate monoesters (Kutscher and Wörner, 1936; Kutscher and Pany, 1938). The enzyme has been purified extensively (London and Hudson, 1953; Boman, 1954; London, Sommer and Hudson, 1955). In addition to hydrolyzing phosphate esters, human prostatic acid phosphatase catalyzes the transfer of phosphate from various donors to alcohols such as glucose, fructose, and methanol (London and Hudson, 1955; Jeffree, 1957). L-Tartrate inhibits the enzyme competitively (Abul-Fadl and King, 1948).

The activity of acid phosphatase in the human prostate is low in childhood and increases about 20 times at puberty (Gutman and Gutman, 1938a). In adult men, the acid phosphatase content of semen seems to reflect the circulating levels of androgenic hormones (Gutman and Gutman,

1940). High levels of acid phosphatase are also present in osteoplastic metastases of prostatic carcinoma (Gutman, Sproul and Gutman, 1936). Acid phosphatase does not seem to enter the circulation from the prostate gland in healthy individuals unless they are subject to prostatic massage. But in about 65 per cent of men with metastatic carcinoma of the prostate, the serum levels of this enzyme are abnormally high (Gutman and Gutman, 1938b; Robinson, Gutman and Gutman, 1939; Huggins and Hodges, 1941). The diagnosis and prognostic evaluation of carcinoma of the prostate in men has been aided greatly by measurements of the acid phosphatase levels of serum. Inhibition of the acid phosphatase activity of blood serum by L-tartrate has been used as an index for the outflow of prostatic acid phosphatase into the serum in neoplastic diseases of the prostate gland (Abul-Fadl and King, 1948; Fishman and Lerner, 1953).

The prostate gland of the monkey (Gutman and Gutman, 1938a) and dog (Huggins and Russell, 1946), and the seminal vesicle of the guinea pig (Bern and Levy, 1952) exhibit powerful acid phosphatase activity, whereas the levels of this enzyme in the prostate of the rabbit (Bern and Levy, 1952) and rat (Huggins and Webster, 1948) are relatively low. The properties of these enzymes from different species are strikingly similar (Novales and Bern, 1953). In the monkey and dog, the prostatic acid phosphatase activities are controlled by androgenic hormones. This is also true in the rat (Stafford, Rubinstein and Meyer, 1949), and guinea pig (Ortiz, Brown and Wiley, 1957).

(2) *Alkaline phosphatase*. An enzyme, activated by magnesium ions, which hydrolyzes a variety of phosphate monoesters at pH 9, is present in the seminal fluid and accessory glands. In some species, e.g., the bull (Reid, Ward and Salisbury, 1948), the levels of seminal alkaline phosphatase are much greater than those of the acid phosphatase. In the rat, alkaline phosphatase activity in the prostate and seminal vesicles decreases markedly after castration (Stafford, Rubinstein and Meyer, 1949).

(3) *5'-Nucleotidase*. Reis (1937, 1938) noticed that human seminal plasma dephos-

phorylated adenosine 5'-phosphate and inosine 5'-phosphate very rapidly. He proposed the term "5'-nucleotidase" for enzymes which specifically hydrolyze the 5'-monophosphates of ribose and its nucleosides. Mann (1945) reported that bull seminal plasma is exceedingly rich in 5'-nucleotidase. The enzyme was purified from this source by Heppel and Hilmoe (1951a). It was inactive towards adenosine 2'- and 3'-phosphates, but catalyzed the hydrolysis of the 5'-monophosphate esters of adenosine, inosine, cytidine, uridine, and ribosyl nicotinamide. The 5'-nucleotidase of bull semen is optimally active at pH 8.5, and requires magnesium ions for maximal activity.

(4) *Inorganic pyrophosphatase*. Heppel and Hilmoe (1951b) reported the presence of an inorganic pyrophosphatase in bull seminal plasma. The enzyme was not purified extensively, and it is not clear whether it is different from other pyrophosphatases in semen.

(5) *Nucleotide pyrophosphatases*. The enzymatic hydrolysis of adenosine triphosphate (ATP) by seminal plasma was observed by Mann (1945) and by MacLeod and Summerson (1946). Three distinct ATPases were isolated from bull seminal plasma by Heppel and Hilmoe (1953). The first of these enzymes catalyzed the hydrolysis of ATP to inorganic pyrophosphate and adenosine 5'-phosphate. The other two catalyzed the liberation of inorganic orthophosphate from ATP, and were active at pH 5 and pH 8.5 respectively. The possible identity of any of these proteins with other enzymes which hydrolyze the pyrophosphate linkage of pyridine nucleotides (Williams-Ashman, Liao and Gotterter, 1958) and cytidine diphosphate choline (Williams-Ashman and Banks, 1956) remains to be established.

The physiologic function of any of the phosphatases in seminal plasma is unknown.

(6) *Proteolytic enzymes*. The proteolytic activity of human semen was first noted by Huggins and Neal (1942), and has been studied extensively by Lundquist and his collaborators. An enzyme similar to pepsinogen, and probably secreted by the seminal vesicles, was discovered in human semen

nal plasma by Lundquist and Seedorf (1952). Three other proteolytic enzymes were partially purified from human semen by Lundquist, Thorsteinsson and Buus (1955). The first enzyme resembled chymotrypsin, and the second was an aminopeptidase. The third enzyme hydrolyzed benzoylarginine ethyl ester, and seems to be identical with the arginine ester hydrolyzing enzyme described in male accessory reproductive glands by Gotterer, Banks and Williams-Ashman (1956). The relationship of these enzymes to the hydrolysis of fibrin or fibrinogen by prostatic secretion is discussed below with reference to the coagulation and liquefaction of semen.

(7) *Glycosidases*. Using phenolphthalein glucuronide as a substrate, Talalay, Fishman and Huggins (1946) determined the  $\beta$ -glucuronidase activity of the male accessory glands of the rat. The levels of this enzyme in the epididymis fall about 50 per cent after castration, and can be restored to normal levels by the administration of testosterone (Conchie and Findlay, 1959). When the corresponding phenol- or *p*-nitrophenol-glycosides were employed as substrates, Conchie, Findlay and Levy (1956) showed that the epididymis of the rat is particularly rich in  $\beta$ -*N*-acetylglucosaminidase. The levels of this enzyme were found by Conchie and Mann (1957) to be very much greater than those of seven other glycosidases in male accessory secretions. The levels of various glycosidases in the epididymis of rodents increases enormously at puberty. In adult animals the activity of some of these enzymes (*e.g.*,  $\alpha$ -mannosidase and  $\beta$ -*N*-acetylglucosaminidase) fell to negligible values after castration, and were restored only partially by treatment with testosterone.

(8) *Miscellaneous enzymes*. The levels of a number of oxidizing enzymes in human seminal plasma were studied by Rhodes and Williams-Ashman (1960), who noted the presence of a very active TPN-linked isocitric dehydrogenase. The ability of human semen to hydrolyze acetylcholine is rather feeble, and the bulk of the activity resides in the seminal plasma (Zeller and Joël, 1941). According to Sekine (1951), boar semen exhibits powerful choline esterase activity, which is confined mainly to the

spermatozoa. The activity of phosphohexoisomerase (Wüst, 1957) and lactic dehydrogenase (MacLeod and Wróblewski, 1958) in human seminal plasma has been documented.

The levels of the following soluble enzymes have been determined in the accessory glands of male rodents: phenol sulfatase (Huggins and Smith, 1947), nonspecific esterase (Huggins and Moulton, 1948), enolase, and dehydrogenases for lactate, malate, glucose 6-phosphate, 6-phosphogluconate and isocitrate (Williams-Ashman, 1954; Rudolph, 1956), aldolase and  $\alpha$ -glycerophosphate dehydrogenase (Butler and Schade, 1958). The nucleoside phosphorylase and adenosine deaminase activities of bull seminal vesicle were measured by Leone and Santoianni (1957). The vesicular secretion of the bull is rich in flavins, and exhibits strong xanthine oxidase activity (Leone, 1953). Leone and Bonaduce (1959) described a very active diphosphopyridine nucleotidase in the vesicular secretion of the bull.

**CONCLUSIONS.** The foregoing survey indicates that, just as the size and morphology of the accessory glands differ profoundly, so there are wide species variations in the chemistry of their secretions, which comprise the seminal plasma. Some seminal constituents (*e.g.*, fructose) are found in many mammals. Other substances, such as ergothioneine, are present in appreciable amounts in the seminal plasma of only a few species. The biochemistry of the accessory glands is still in its infancy, and it may be expected that future research will disclose other species-restricted components of seminal plasma. Mann (1954a, 1956) rightly emphasizes that the finding of substantial concentrations of certain substances in the semen of only relatively few species does not necessarily detract from their physiologic value. The high levels of ergothioneine in the seminal plasma of the boar and stallion is a case in point. The ejaculates of these species have peculiarities which may render their spermatozoa particularly susceptible to the immobilizing action of oxidizing agents, and the suggestion (Mann and Leone, 1953; Mann, Leone and Polge, 1956) that ergothioneine, in virtue of its reducing properties, serves a pro-

fective function in boar and stallion semen seems an eminently reasonable one. However, the accessory glands of many animals secrete certain substances (*e.g.*, glycerophosphoryletholine, spermine, citric acid) that do not appear to be of any particular value for the survival of spermatozoa in the male or female genital tracts. Perhaps these substances are simply by-products of the secretory mechanisms of the glands from which they originate, or represent biochemical vestiges.

The widespread occurrence of fructose in accessory gland secretions deserves further comment. The only other situation where large amounts of fructose are present in mammalian extracellular fluids under normal physiologic conditions is in the fetal blood of ungulates (Bernard, 1855; Bacon and Bell, 1948; Alexander, Huggett, Nixon and Widdas, 1955). Mammalian spermatozoa metabolize glucose just as well as fructose as a source of energy under anaerobic and aerobic conditions. Indeed, glucose has been used widely as the sole glycolyzable sugar in artificial diluents employed in the storage of semen for artificial insemination (Mann, 1954a). Thus fructose does not seem to be more beneficial than glucose to the well being of spermatozoa. There is evidence that the utilization of fructose, in contrast to glucose, is not impaired in the diabetic state (Chernick, Chaikoff and Abraham, 1951; Renold, Hastings and Nesbitt, 1954). It is conceivable that the presence of fructose in semen would render the spermatozoa relatively insensitive to insulin. But it would seem more probable that the physiologic value of seminal fructose is related to factors other than the maturation or survival of spermatozoa. Mann (1954a) has pointed out that if glucose were the only glycolyzable sugar in semen, its concentration would not be expected to exceed that of blood. The transformation of blood glucose into seminal fructose by the accessory glands permits the establishment of very high levels of fructose in semen. Furthermore, the formation of seminal fructose is strictly controlled by androgenic hormones, and it would be hard to conceive of a similar hormonal dependence of glucose levels in semen.

Although the volume and chemical com-

position of seminal plasma are influenced by many factors, androgenic hormones are undoubtedly the principal determinants of the secretory activity of the accessory glands. Chemical and enzymatic constituents of accessory gland secretions such as fructose, citric acid, and acid phosphatase have proved to be exquisitely sensitive indicators of androgenic activity. The application of such "chemical tests" for androgen action has provided important corroborative evidence for previous conclusions, based on purely morphologic studies, that the initiation of mature secretory function of the accessory glands precedes the appearance of sperm in the seminiferous tubules, and also that the adverse effects of malnutrition on the functional activity of the prostate gland and seminal vesicle are mediated via the hypophysis. Chemical investigations have established that the major portion of certain components (glycerophosphoryletholine, glycosidases) of the seminal plasma of some species originates from the epididymis. The way to the successful treatment of metastatic carcinoma of the prostate in man by anti-androgenic measures was paved by the availability of a chemical systemic index of the hormonal dependence of many of these neoplasms, *viz.*, the acid phosphatase of blood serum. Changes in the chemistry of some accessory organs (*e.g.*, the fructose content of the rat coagulating gland) seem to be more sensitive indicators of the action of exogenous androgens in castrated animals than the weights or histologic structure of these organs. The application of such chemical methods to the bioassay of androgens holds much promise for the future.

Finally, it may be mentioned that chemical studies of the secretions of the accessory glands have given insight into the homology of these organs. The finding of high concentrations of citric acid, but not of fructose, in the rat female prostate after stimulation with androgens shows that the secretion of this tissue resembles that of the ventral prostate gland of the male rat. On the other hand, structures which are usually considered to be anatomically and functionally homologous may secrete quite different substances. Thus in the guinea pig and bull, both citric acid and fructose

are secreted by the seminal vesicles, whereas in the rat, citric acid is produced by the seminal vesicles and fructose is formed only in the dorsolateral prostate and coagulating glands.

#### D. METABOLISM OF THE PROSTATE AND SEMINAL VESICLE

The metabolism of the male accessory reproductive glands, and the activity of many enzymes therein, are influenced profoundly by steroid hormones. In adult animals, excision of the testes results in a rapid decline in the respiration, but not of the anaerobic glycolysis, of slices of the prostate gland of the dog (Barron and Huggins, 1944), and of the rat prostate (Homma, 1952; Nyden and Williams-Ashman, 1953; Bern, 1953; Rudolph and Starnes, 1954; Butler and Schade, 1958) and seminal vesicle (Rudolph and Samuels, 1949; Porter and Melampy, 1952; Rudolph and Starnes, 1954). The post-castrate fall in oxygen consumption by these tissues can be reversed by the administration of testosterone. The respiration of the epithelium (but not of the muscle) of the guinea pig seminal vesicle responds in a similar way to androgen deprivation (Levey and Szego, 1955b). The stimulatory effect of testosterone on the respiration of the prostate gland and seminal vesicle of castrated rats is not prevented by the simultaneous administration of hydrocortisone (Rudolph and Starnes, 1954).

The activity of a number of respiratory enzymes in the rat prostate gland is decreased by castration to about the same extent as the respiration of slices of this tissue. This is true for the succinic and cytochrome oxidase systems (Davis, Meyer and McShan, 1949), and for fumarase, acetonitase, and malic dehydrogenase (Williams-Ashman, 1954). But the succinic oxidase levels in two other androgen-sensitive tissues are uninfluenced by castration, *viz.*, the epithelium of the guinea pig seminal vesicle (Levey and Szego, 1955b), and the levator ani muscle of the rat (Leonard, 1950). In the rat prostate, androgens have little influence on the activity of the glycolytic enzymes enolase and lactic dehydrogenase, and of the TPN-specific enzymes which oxidize isocitrate, glucose 6-phos-

phate and 6-phosphogluconate (Williams-Ashman, 1954; Rudolph, 1956). The enzymatic machinery responsible for the respiration of the male accessory glands seems to be similar to that of other mammalian tissues (Barron and Huggins, 1946a, b; Nyden and Williams-Ashman, 1953; Williams-Ashman, and Banks, 1954b; Williams-Ashman, 1954, 1955; Levey and Szego, 1955a). Glock and McLean (1955) have shown that, as in most other mammalian tissues, the levels of DPN in rodent prostate and seminal vesicle are higher than those of DPNH, whereas the content of TPNH is much greater than that of TPN.

Nyden and Williams-Ashman (1953) found that the respiration-coupled synthesis of long-chain fatty acids from acetate by ventral prostate slices *in vitro* was depressed by castration to a greater extent than the respiration, and could be restored to normal levels by testosterone therapy. Certain other synthetic reactions (the incorporation of  $P^{32}$ -labeled inorganic phosphate into phospholipids, total nucleic acids, and phosphoproteins) were less sensitive to androgens under these conditions. However, in experiments involving the injection of  $P^{32}$ -labeled inorganic phosphate into animals, the administration of androgen increased the turnover of various acid-insoluble phosphorus containing fractions. Thus Levin, Albert and Johnson (1955) observed that testosterone increases the turnover of various phospholipids in the prostate gland and seminal vesicle. In the seminal vesicle, Fleischmann and Fleischmann (1952) found that the entry of  $P^{32}$  into the desoxyribonucleic acid fraction was increased 100-fold by androgen administered to castrate rats, whereas the specific radioactivity of the ribonucleic acid was increased only 2-fold. Cytoplasmic basophilia in the rat seminal vesicle (Melampy and Cavazos, 1953), and the endoplasmic reticulum of the ventral prostate gland (Harkin, 1957a), which are intimately associated with cytoplasmic ribonucleic acid, are influenced profoundly by androgenic hormones.

Transamination between glutamate and either pyruvate or  $\alpha$ -ketoglutarate was shown by Barron and Huggins (1946b) to proceed rapidly in canine and human pros-

tate tissues. Awapara (1952a, b) reported that the alanine (but not aspartic) transaminase activities of the ventral prostate gland of the rat were decreased by castration, and increased by testosterone therapy.

Rudolph and Starnes (1954) studied the water distribution in the rat accessory glands. The extracellular water in normal seminal vesicles and prostates was 13.8 per cent and 8.5 per cent, respectively. The corresponding values in castrate animals were 37.0 per cent and 31.8 per cent. The growth of the glands which resulted from treatment with testosterone was accompanied by a greater increase in the intracellular water than in extracellular water. Rudolph and Samuels (1949) provided evidence that changes in the water content of seminal vesicles induced by treatment of castrate rats with testosterone did not precede metabolic changes (*e.g.*, fructose synthesis) in this tissue.

The pronounced effects of androgen administration *in vivo* on the metabolism and enzymatic activity of the accessory glands cannot be mimicked by the addition of androgens *in vitro*. Dirscherl, Breuer and Scheller (1955) reported that low levels of testosterone stimulated the respiration of mouse seminal vesicles if the control respiration was low. But others have found that the respiration and glycolysis of male accessory glands are uninfluenced by the direct addition of androgens *in vitro* except at high concentrations ( $>5 \times 10^{-5}$  M), at which testosterone is inhibitory (Bern, 1953; McDonald and Latta, 1954, 1956; Andrewes and Taylor, 1955). According to Farnsworth (1958), the direct addition of testosterone to prostate tissue impedes citrate synthesis to a greater extent than oxygen consumption. Williams-Ashman (1954) found that the *in vitro* addition of testosterone did not affect the activity of a number of respiratory and glycolytic enzymes in the rat ventral prostate gland.

The mechanism of action of androgenic hormones at a molecular level is not known. There is no evidence that androgens are *directly* involved in the large changes in the activity of some enzyme systems in accessory glands which follow the administration or deprivation of these hormones. Recent studies which indicate that minute concen-

trations of certain steroid hormones can stimulate the transfer of hydrogen between pyridine nucleotides by isolated enzyme systems deserve further comment. A soluble enzyme in human placenta catalyzes an estradiol-17 $\beta$ -dependent exchange of hydrogen between TPNH and DPN (Talalay and Williams-Ashman, 1958). There is evidence in favor of the hypothesis (Talalay, Hurlock and Williams-Ashman, 1958; Talalay and Williams-Ashman, 1960) that estradiol-17 $\beta$  transports hydrogen in this reaction by undergoing reversible oxidation to estrone:

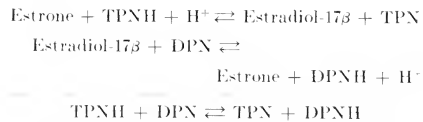

Hagerman and Villet (1959), however, believe that estradiol-17 $\beta$  and estrone mediate transhydrogenation between TPNH and DPN by a mechanism which does not involve oxido-reduction of the steroids. Hurlock and Talalay (1958) showed that a soluble 3 $\alpha$ -hydroxysteroid dehydrogenase isolated from rat liver catalyzes hydrogen transfer between pyridine nucleotides in the presence of catalytic levels of androsterone and some other 3 $\alpha$ -hydroxysteroids. In this instance also, it seems that the steroids act in a coenzyme-like manner by undergoing alternate oxidation and reduction. However, biologically inactive steroids such as etiocholan-3 $\alpha$ -ol-17-one are even more active than androgenic substances such as androsterone in this isolated enzyme system. Hurlock and Talalay (1959) reported that the particle-bound 3 $\alpha$ - and 11 $\beta$ -hydroxysteroid dehydrogenases of rat liver react at comparable rates with both TPN and DPN, and they suggest that these dehydrogenases might function as transhydrogenases in the presence of their appropriate steroid substrates. The hydroxysteroid dehydrogenases for which there is direct or circumstantial evidence for their ability to function as transhydrogenases are localized either in the microsomes (endoplasmic reticulum) or in the soluble cell sap. Other enzymes that catalyze the transfer of hydrogen between pyridine nucleotides are bound to the mitochondria of many animal tissues (Stim,

Kaplan and Ciotti, 1959; cf. Talalay, Hurlock and Williams-Ashman, 1958). These mitochondrial transhydrogenases do not require steroid hormones as cofactors. According to Humphrey (1957), the large cytoplasmic particles of rat prostate gland and seminal vesicle are devoid of transhydrogenase activity. Slices of human prostate gland convert testosterone to androst-4-ene-3,17-dione (and other metabolites) (Wotiz and Lemon, 1954; Wotiz, Lemon and Voulgaropoulos, 1954). This suggests that the human prostate contains a 17 $\beta$ -hydroxy-steroid dehydrogenase which could conceivably function as a transhydrogenase in the presence of low levels of testosterone. Baron, Gore and Williams (1960) reported the presence of androsterone-stimulated transhydrogenase reactions in the prostate gland of rodents and man. On the contrary, Williams-Ashman, Liao and Gotterer (1958), and Samuels, Harding and Mann (1960) were unable to demonstrate any activation by testosterone of hydrogen transfer between TPNH and DPN in rat prostatic tissue. DPNH and TPNH serve rather different metabolic functions (cf. Talalay and Williams-Ashman, 1958), and it is possible that steroid-mediated transhydrogenations might exert a controlling influence over the balance between the oxidized and reduced forms of pyridine nucleotides in the extramitochondrial regions of certain cells. However, at present there is no direct evidence in support of this hypothesis (cf. Talalay and Williams-Ashman, 1960).

#### E. COAGULATION OF SEMEN

Mammalian semen is emitted from the urethra as a liquid. In some species, *e.g.*, the bull and the dog, the semen remains permanently in the liquid state. But the seminal fluid of many other mammals may undergo remarkable changes in its physical properties on standing. Rodent semen clots rapidly and, if ejaculated into the vagina, forms a solid vaginal plug. This structure assists fertilization by preventing an outflow of semen from the vagina after copulation (Blandau, 1945). The subsequent dissolution of the vaginal plug, probably as the result of the action of leukocytic enzymes, was studied by Stockard and Papanicolaou (1919). A copulatory plug has

also been described in certain Insectivora, Chiroptera, and Marsupiala (Camus and Gley, 1899; Engle, 1926a; Courier, 1925; Eadie, 1948a, b).

It has been stated that in the opossum (Hartman, 1924) and in the bat (Courier, 1925), the vaginal plug results from the coagulation of the female secretions by seminal plasma. However, the semen of many other species clots on its own accord. Camus and Gley (1896, 1899) were the first to recognize that in the rat and guinea pig, the clotting process involves the solidification of the vesicular secretion by an enzyme of prostatic origin, which they termed vesiculase. The classical experiments of Walker (1910a, b) showed that this enzyme is secreted solely by the anterior prostate or "coagulating" gland. In the rhesus monkey, the secretion of the cranial lobe (but not of the caudal lobe) of the prostate gland coagulates the vesicular secretion (van Wageningen, 1936). The "soft calculus" frequently present in the urinary bladder of male but not female rats is probably formed by clotting of the seminal vesicle secretion by the action of enzymes from the coagulating gland (Vulpé, Usher and Leblond, 1956).

More recently, the mechanism of action of vesiculase has been studied in considerable detail. A crude preparation of the proteins of the vesicular secretion that are clotted by this enzyme can be obtained in a stable form, and the clotting process may be measured quantitatively by simple spectrophotometric procedures (Gotterer, Ginsburg, Schulman, Banks and Williams-Ashman, 1955; Gotterer and Williams-Ashman, 1957; Zorogniotti and Brendler, 1958). The over-all coagulation process is extremely sensitive to the ionic strength of the solution in which it takes place, and is abolished by the addition of metal chelating agents such as Versene (ethylenediaminetetraacetic acid), *o*-phenanthroline, and  $\alpha, \alpha'$ -dipyridyl, and also by heavy metals such as mercuric ions. The inhibitory action of Versene can be overcome by manganous ions, or by somewhat higher concentrations of calcium ions. Experiments involving the delayed addition of either heavy metal ions or of metal chelating agents established that the coagulation process can be separated



into two distinct phases (Gotterer and Williams-Ashman, 1957). The first of these requires a metal ion such as  $Mn^{++}$ , is inhibited by Versene, and does not necessarily involve the precipitation of insoluble material. The second phase, which is insensitive to the action of metal chelating agents, is inhibited by mercuric ions and leads to the formation of a coagulum. The coagulated material is protein in nature.

Further fractionation of the vesicular secretion by Speyer (1959) led to the isolation of a heat-stable protein, coagulogen, which is the precursor of the insoluble material of the vaginal plug, but is not clotted by vesiculase. Speyer (1959) isolated another, heat-labile protein from vesicular secretion which he designated procoagulase, and which is converted into a clotting enzyme coagulase by the action of vesiculase. The coagulation of the seminal vesicle secretion by the prostatic enzyme vesiculase thus seems to take place by the following reactions:

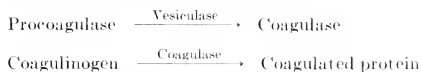

Only the first reaction is inhibited by Versene.

Partial purification of vesiculase has been achieved (Gotterer, Ginsburg, Schulman, Banks and Williams-Ashman, 1955). Vesiculase is quite distinct from another enzyme in the secretion of the coagulating gland of guinea pigs which hydrolyzes, *in vitro*, tosyl-L-arginine methyl ester (TAME) (Gotterer, Banks and Williams-Ashman, 1956). Unlike thrombin, vesiculase does not hydrolyze TAME and does not clot fibrinogen. The dissimilarity between the coagulation of blood and of semen is further borne out by the failure of thrombin to clot the proteins of the vesicular secretion, and by the inability of TAME (which depresses the action of thrombin) to inhibit vesiculase action.

Electrical stimulation of the head of the guinea pig induces ejaculation without voiding of either urine or feces (Batelli, 1922). Ejaculates obtained in this manner from normal, sexually mature guinea pigs coagulate rapidly. After castration, the semen is no longer coagulable, but becomes

so a few days after treatment with androgens (Moore and Gallagher, 1930). This "electric ejaculation test" can be used as an indicator for androgenic activity (*cf.* Sayles, 1939, 1942).

It is generally believed that human semen is ejaculated as a fluid, and then coagulates (Lane-Roberts, Sharman, Walker and Wiesner, 1939; Joël, 1942; Huggins and Neal, 1942; Lundquist, 1949), although some authors state that it is emitted in a gelatinous form (Pollak, 1943; Hammen, 1944; Oettle, 1954). But there is no doubt that the semen from normal men subsequently liquefies if kept at room temperature.<sup>3</sup> Human semen possesses strong fibrinolytic activity (Huggins and Neal, 1942; Harvey, 1949; Ying, Day, Whitmore and Tagnon, 1956). The prostatic gland of men secretes a proteolytic enzyme, fibrinolysin, which is probably responsible for the phenomenon of liquefaction. Prostatic fibrinolysin is produced in large amounts by certain cancers of the prostate in man, and seems to enter the circulation since there is a pronounced bleeding tendency in such patients (Tagnon, Schulman, Whitmore and Leone, 1953; Scott, Matthews, Butterworth and Frommeyer, 1954; Swan, Wood and Owen, 1957). Canine semen, which does not clot, contains little fibrinolysin, but is rich in another proteolytic enzyme, fibrinogenase, which hydrolyzes fibrinogen. Little fibrinogenase is present in human semen (Huggins and Neal, 1942). The presence of related proteolytic enzymes in the secretions of the male accessory glands is described above.

<sup>3</sup>Louis Nicolas Vauquelin published the first paper on the chemistry of seminal fluid (Vauquelin, 1791). This remarkable study includes a detailed and accurate account of the liquefaction of human semen which is quite unexcelled by later writings. It also describes the formation, in ejaculates which had stood for three or four days, of "cristaux transparents, d'environ une ligne de long, très-minces, et qui se croisent souvent de manière à représenter les rayons d'une roue. Ces cristaux isolés nous ont offert, à l'aide d'un verre grossissant, la forme d'un solide à quatre pans, terminés par des pyramides très-allongées, à quatre faces." Although Vauquelin believed that these crystals were composed of calcium phosphate, Mann (1951) has pointed out that he had, in reality, observed the deposition of spermine phosphate in the semen.

Freund and Thompson (1957) reported that intravenous injection of crude guinea pig coagulating gland secretion into rabbits or guinea pigs induces hypotensive shock. Edema results if the secretion is injected locally. The secretion of the coagulating gland of the rat does not possess these properties. Further studies by Freund, Miles, Mill and Wilhelm (1958) showed that two main protein fractions can be separated from the secretion of the guinea pig coagulating gland by preparative starch electrophoresis. Fraction I was hypotensive and a potent permeability factor in rabbits and guinea pigs. It hydrolyzed TAME rapidly and may be identical with the TAME-hydrolyzing enzyme described in guinea pig coagulating gland by Gotterer, Banks and Williams-Ashman (1956). The latter enzyme is not present in the coagulating gland of the rat. Fraction II isolated by Freund and his associates is probably vesiculase.

### III. Structure and Function in Relation to Hormones

#### A. INTRODUCTION

Some of the effects of removal of the testes in males have been recognized ever since castration was first practiced on man and domestic animals. Aristotle's writings include accurate descriptions of the effects of castration on secondary sex characters in birds and in man. The classical studies of John Hunter (1792) laid the basis for an understanding of the relation between the presence of the testes and the size and functional state of the accessory reproductive glands of mammals, although he did not postulate the existence of testicular hormones.

Hunter demonstrated experimentally that the seminal vesicles of guinea pigs are not reservoirs for semen and concluded that this applies to the seminal vesicles in man and in other mammals. He not only described the gross anatomy of the seminal vesicles in many species (hedgehog, mole, man, boar, bull, horse, buck, mouse, rat, beaver, guinea pig) and their absence from others, but he observed that they are smaller in the gelding than in the stallion. In reference to other glands, he generalized

that "the prostate gland, Cowper's glands and the glands along the urethra . . . are in the perfect male large and pulpy, secreting a considerable quantity of slimy mucus which is salt to the taste . . . while in the castrated animal these are small, flabby, tough and ligamentous, and have little secretion." In addition, he made the equally important discovery that the testes of mammals (and birds as well) are very small in winter in animals "which have their seasons of copulation" and the seminal vesicles and prostates are "hardly discernable." He concluded that "from these observations it is reasonable to infer that the use of the vesiculae in the animal economy must, in common with many other parts, be dependent upon the testicles."

Over 100 years later, many of his observations were rediscovered, extended, and interpreted in the light of the first demonstration that the testis is an endocrine organ (Berthold, 1849). In the early part of the 20th century the interest in attempting to isolate and characterize androgens from testis tissue and urine led to a search for rapid and dependable bioassay methods. The cock's comb provided a sensitive and convenient test object (Pézar, 1911). In addition, some of the accessory reproductive glands of mammals were found to atrophy rapidly after castration and proved also to be sensitive indicators for the presence of androgenic hormones. Cytologic tests using the rat prostate, seminal vesicles, and Cowper's glands were developed and an electric ejaculation test in the guinea pig was devised (Moore, 1932, 1939). Weights, sizes, cytologic structure, and mitotic activity in mouse seminal vesicles were suggested as bioassay methods for androgenic hormones (Deanesly and Parkes, 1933).

After the successful isolation and chemical characterization of androgens and estrogens from various sources, interest centered on the fundamental relationships of androgens to normal development, histologic structure, and secretory activity of the accessory glands in many species of mammals. The effects of estrogens and gestagens and the competitive and synergistic relationships of steroid hormones were

examined. The results of this early work contributed extensively to the fields of biochemistry, biology, and medicine. More recently there have been studies on the relation of hormones to the ultrastructure, histochemistry, and metabolism of the glands, and to the chemical composition of their secretions (Section II).

In the following section, the hormonal control of structure and function will be discussed with particular reference to the numerous studies on the prostate glands and seminal vesicles of rats and mice.

#### B. EFFECTS OF ANDROGENS

The term androgen will be used in the collective sense for substances that are capable of stimulating accessory reproductive glands in castrated animals and maintaining normal histologic structure and secretory activity in the epithelium. Androgenic substances are formed by the testes, ovaries, and adrenal cortex. All androgens which have been characterized are steroids. The urine contains many androgen metabolites, mainly in the form of their conjugates with either glucuronic or sulfuric acids. Testosterone is the principal androgen secreted by the testis and this substance, or the longer acting testosterone propionate, is most commonly used as a replacement for testicular androgen. In the last two decades a number of unnatural androgens (*e.g.*, 17 $\alpha$ -methyl testosterone) have been synthesized and found to possess strong biologic activity. The relationship between chemical structure of steroids and andro-

genic activity in a variety of bioassay procedures is discussed by Dorfman and Shipley (1956).

#### 1. Testicular Androgens

The effects of endogenous and exogenous androgen on weight, histologic structure, and secretory activity of the accessory glands have been reviewed by Moore (1939), Price (1947), Burrows (1949), Dorfman (1950), Dorfman and Shipley (1956) and many others. Aspects of metabolic activity have been treated by Roberts and Szego (1953) and Mann (1954a).

The first detailed cytologic studies of male accessory glands and the changes following castration and hormone administration were made on the prostates, coagulating glands, and seminal vesicles of adult rats (Moore, Price and Gallagher, 1930; Moore, Hughes and Gallagher, 1930). Extensive research on structure and function of these and other accessory glands in many species followed this early work, but the cytologic structure of prostates and seminal vesicles of rats and mice remains one of the most sensitive indicators for androgenic hormones.

**RAT PROSTATE AND SEMINAL VESICLES.** *Ventral prostate.* In the normal adult gland, the columnar secretory epithelium has basal nuclei with conspicuous nucleoli and chromatin particles, and a supranuclear clear zone or light area in the cytoplasm corresponding to the position of the Golgi zone (Figs. 6.8, 6.9, and 6.14). In osmium preparations, the Golgi apparatus appears as

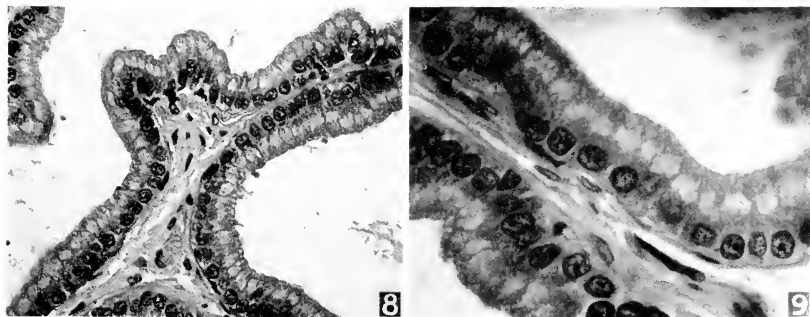

FIGS. 6.8 AND 6.9. Rat ventral prostate from a normal adult male.  $\times 500$  and  $1000$ . Bouin-hematoxylin preparations. (From C. R. Moore, D. Price and T. F. Gallagher, *Am. J. Anat.* 45, 71-107, 1930.)

heavy strands or networks (Figs. 6.19 and 6.22) which do not conform precisely to the shape or area of the cytoplasmic clear zone. Mitochondria are distributed as rods or granules in all parts of the cell. The secretion in the lumina of the alveoli is eosinophilic and mainly granular. A basement membrane rests on a stroma of connective tissue containing smooth muscle strands and blood vessels. Occasional small basal cells are wedged between the tall secretory cells. These observations were made by light microscopy of tissues fixed and stained by routine methods (Moore, Price and Gallagher, 1930).

Electron microscopy (Harkin, 1957a) shows that the epithelial cells have an endoplasmic reticulum or ergastoplasm composed of membrane-lined sacs with a finely granular component in the spaces between them (Figs. 6.27 to 6.29); the outside of the thin membrane is studded with Palade's granules (Palade, 1955). The arrangement of the sacs tends to parallel the long axis of the cells, but in cross section the pattern appears concentric or lamellar, particularly in the supranuclear region (Fig. 6.29). The ergastoplasmic sacs occupy more space than the matrix apically, but basally the two are equally prominent (Fig. 6.28). The mem-

TABLE 6.6  
*Summary of the effects of testicular androgen on the rat prostate and coagulating glands*

Normal Males	Castrated Males
General Characteristics	
All lobes	
<i>alveoli</i> with folded mucosa; secretion in the lumina . . .	Size reduced; villi lost; secretion reduced
<i>columnar epithelial cells; cytoplasm granular or foamy. . .</i>	Size reduced; pseudostratified; cytoplasm less dense
<i>supranuclear clear zone</i> in cytoplasm (ventral lobe)	Clear zone lost
<i>Golgi</i> supranuclear networks . . .	Reduced in amount; fragmented
<i>mitochondria</i> as rods or granules	Still numerous but reduced in relative numbers
<i>nuclei</i> basal or central	Shrunken and pyknotic
<i>stroma</i> of connective tissue and smooth muscle	Increased fibromuscular tissue
Specific Characteristics	
Ventral lobes	
Histochemical observations:	
<i>secretion</i> in lumina strongly PAS- and alkaline phosphatase-positive	Some phosphatase activity retained
<i>cytoplasm</i> weak PAS, strong alkaline phosphatase activity; . . .	Phosphatase activity low
<i>basophilic</i> reaction except in clear zone	
<i>Golgi</i> accumulations of PAS-positive granules	
<i>stroma</i> some alkaline phosphatase activity. . .	Retained
Electron microscopic observations:	
<i>cytoplasm</i> moderately distended ergastoplasmic sacs	Sacs collapsed; granular component reduced
<i>Golgi</i> supranuclear microvesicular complex	Reduced in size
<i>mitochondria</i> numerous, prominent apically. . . .	Reduced in relative numbers
Lateral lobes	
Histochemical observations:	
<i>cytoplasm</i> luminal border organelle with high concentrations of zinc and basophilic material; osmiophilic, argentophilic	
<i>nucleoli</i> high concentrations of zinc and marked basophilia	
<i>stroma</i> high concentrations of zinc; basophilic material present	
Dorsal lobes	
Histochemical observations:	
<i>cytoplasm</i> in apical region strongly basophilic; basally, some zinc	
<i>nucleoli</i> high concentrations of zinc and marked basophilia	
<i>stroma</i> basophilic material; strong alkaline phosphatase reaction . . .	Phosphatase activity unaltered
Electron microscope observations:	
<i>cytoplasm</i> distended ergastoplasmic cisternae; . . .	Cisternae collapsed; RNA-rich granules reduced
Coagulating glands (anterior prostate)	
Histochemical observations:	
<i>secretion</i> strongly PAS positive	
<i>cytoplasm</i> weak PAS reaction	
<i>stroma</i> some alkaline phosphatase activity. . .	Activity appears unaltered
Electron microscope observations:	
<i>cytoplasm</i> extremely dilated ergastoplasmic cisternae . . .	Cisternae collapsed; granules reduced

brane is continuous with the outer nuclear membrane. The Golgi complex is conspicuous as microvesicles midway between nucleus and lumen. Mitochondria lie in the matrix between the sacs and are very prominent in the most apical region. Microvilli project into the lumina of the alveoli with no interruption of the cytoplasmic, or plasma, membrane. The membrane at the base of the cell is double (see Fig. 6.28); one component, the basement membrane, continues unbroken under adjacent cells; the second forms a part of the double plasma membrane between cells. Brandes and Groth (1961) have confirmed Harkin's findings and added further observations. Nuclei contain patches of granules which are frequently along the inner nuclear membrane; the Golgi complex consists of vesicles, vacuoles, and parallel membranes; vesicles and granules surrounded by smooth-surfaced membranes are disposed in the cytoplasmic matrix and are more numerous apically; the dilated sacs or cisternae of the supranuclear region seem to intercommunicate.

Histochemical studies of basophilia, alkaline phosphatase activity, and the localization of periodic acid-reactive carbohydrates (Periodic acid-Schiff or PAS reaction) add further information (Table 6.6). Davey and Foster (1950) found basophilia (which was abolished by ribonuclease) distributed through the cytoplasm except in the clear area described by Moore, Price and Gallagher (1930) as corresponding to the position of the Golgi zone. Stroma of the ventral prostate shows some degree of alkaline phosphatase activity but luminal secretion and epithelial cells are strongly positive (Bern, 1949a), especially at the luminal and basal borders (Stafford, Rubenstein and Meyer, 1949). The secretion also gives a fairly intense PAS reaction whereas the epithelial cells are only slightly reactive; occasionally the Golgi apparatus is visible as PAS-positive granules (Leblond, 1950).

After castration, there is reduction in cell height and loss of the cytoplasmic clear zone (Fig. 6.15) within 4 days. On subsequent days, cell size continues to decrease and nuclei become small and pyknotic (Figs. 6.10, 6.16 to 6.18). The Golgi ap-

paratus begins to fragment by 10 days; by 20 days it consists of granules much reduced in amount (Fig. 6.20) and the basement membrane of the cells disappears (Moore, Price and Gallagher, 1930).

Harkin (1957a) reported changes observable by electron microscopy within 24 hours after castration; distention of apical ergastoplasmic sacs and reduction in size and number of microvilli. By 2 days, there is dilation of Golgi microvesicles, collapse of the apical ergastoplasmic sacs, and reduction in mass of apical cytoplasm; at 4 days, massive collapse of sacs, reduction in mitochondrial number, and increase in electron-dense bodies (Fig. 6.30). The granular component is not reduced until 8 days after castration or longer. Brandes and Portela (1960a) noted, briefly, collapse in the cisternae of the ergastoplasm, loss of the ribonucleic acid- (RNA) rich granules from the membranes of the endoplasmic reticulum, and apparent increase in mitochondria but with a reduction in their size (Table 6.6).

The distribution of alkaline phosphatase in the stroma, epithelium, and secretion is unchanged 32 days after castration; the stroma is still reactive at 120 days but the epithelium is completely atrophic (Bern and Levy, 1952). Quantitative determinations of alkaline and acid phosphatases showed, however, that activities of both enzymes are reduced markedly by 8 days (Stafford, Rubenstein and Meyer, 1949). The epithelium loses the ability to secrete citric acid (see Section II).

Changes after gonadectomy are prevented or reversed by administration of androgenic substances. Extracts of bull testes (Moore, Price and Gallagher, 1930) prevented involution of the epithelium in castrates (Fig. 6.11 and 6.21) and androst-erone, testosterone, and testosterone propionate prevented or repaired castration changes (Moore and Price, 1937, 1938). The response of the castrate to androgen is rapid; cell hypertrophy begins within 23 hours after a single injection of testosterone propionate into males castrated for 40 days; at 35 hours mitotic activity begins and reaches a maximum at 43 hours (Burl-hart, 1942).

Ergastoplasmic sacs in the epithelium

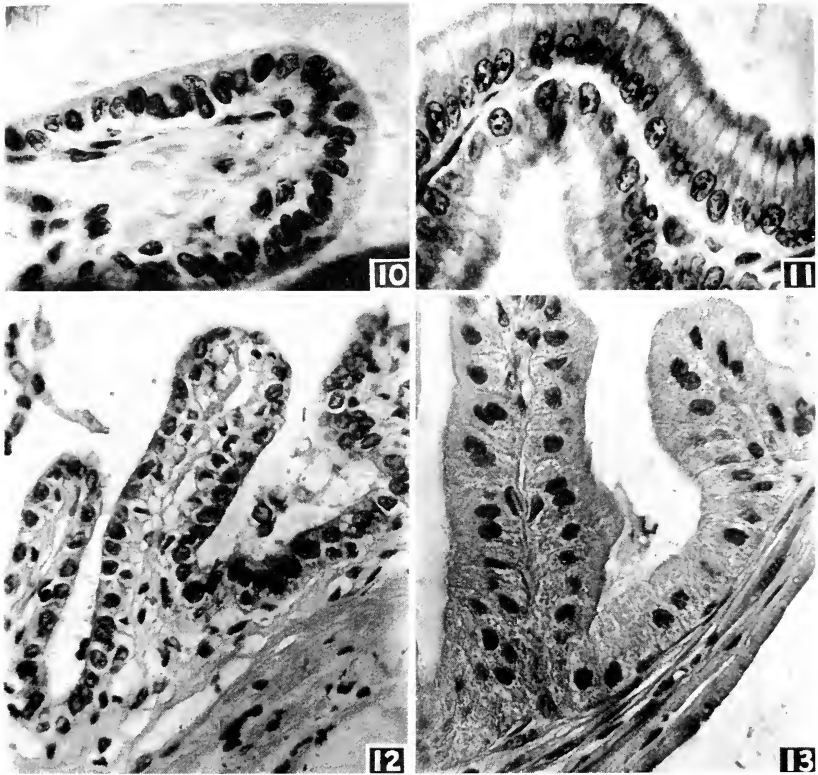

FIGS. 6.10-6.13. Rat ventral prostate (Figs. 6.10, 6.11) and coagulating gland (Figs. 6.12, 6.13). All photomicrographs  $\times 1000$ . Fig. 6.10, 20-day castrate. Fig. 6.11, 20-day castrate injected with testis extract. Fig. 6.12, 20-day castrate. Fig. 6.13, 20-day castrate injected with testis extract. (From C. R. Moore, D. Price and T. F. Gallagher, *Am. J. Anat.*, **45**, 71-107, 1930.)

are prevented from collapsing by treatment of castrates with testosterone and the process is reversed if the androgen is given after castration changes have developed (J. C. Harkin, personal communication). Alkaline and acid phosphatase levels are essentially normal in castrates injected with testosterone propionate (Stafford, Rubinstein and Meyer, 1949).

*Lateral prostate.* The epithelial cells in normal adult glands are columnar and the nuclei are basal, but cell size and nuclear position are more variable than in the ventral prostate (Korenchivsky and Dennison, 1935). The Golgi apparatus appears as

prominent supranuclear networks in osmium stained preparations (Rixon and Whitfield, 1959).

Histochemical studies employing a dithizone zinc stain demonstrated high concentrations of zinc in the apical part of the cells (Gunn and Gould, 1956a). Fleischhauer (1957) observed (macroscopically) heavy staining that was visible in this lobe after intravenous or subcutaneous injections of dithizone. In unfixed frozen sections, he found in the basal regions of all epithelial cells numerous stained granules which he interpreted as zinc-positive material. The nature of a rather wide diffusely

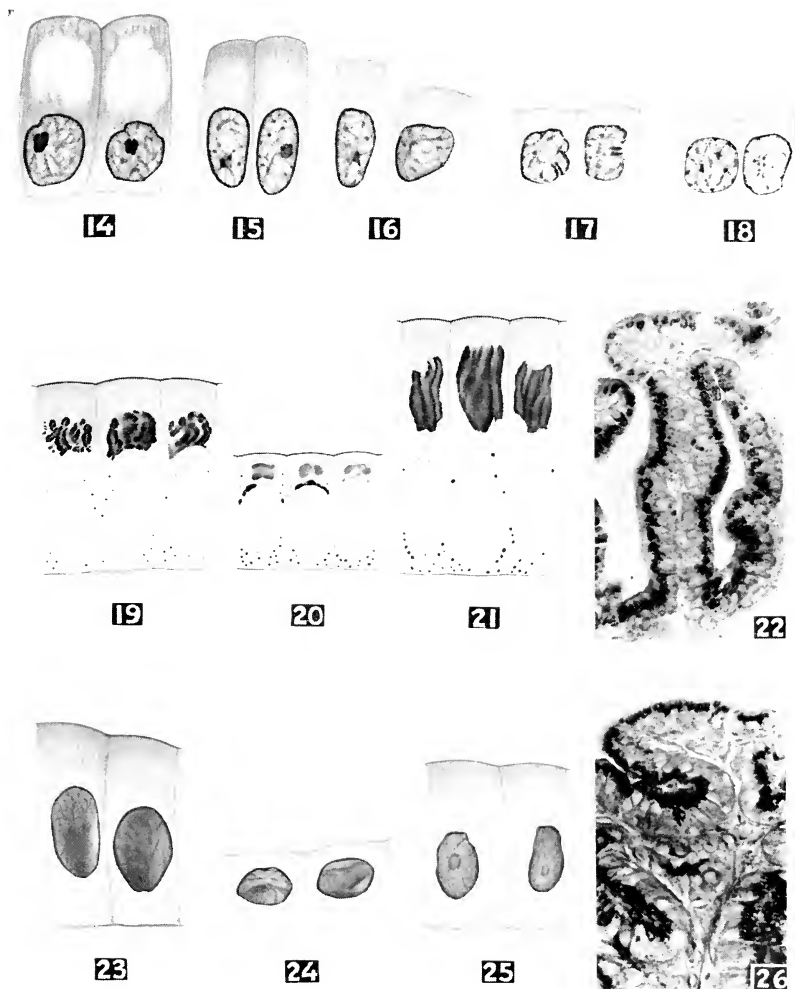

Figs. 6.14-6.26

Figs. 6.14-6.22. Rat ventral prostate. Figs. 6.14-6.21. Camera lucida drawings  $\times 3000$ . Figs. 6.19-6.22. Mann-Kopsch preparations for Golgi apparatus. Fig. 6.14. Normal male. Figs. 6.15-6.18. From males castrated for 4, 10, 20 and 90 days. Fig. 6.19. Normal male. Fig. 6.20. 20-day castrate. Fig. 6.21. 20-day castrate injected with testis extract. Fig. 6.22. Normal male; photomicrograph  $\times 1000$ . (From C. R. Moore, D. Price and T. F. Gallagher, *Am. J. Anat.*, **45**, 71-107, 1930.)

Figs. 6.23-6.26. Rat coagulating gland. Figs. 6.23-6.25. Camera lucida drawings  $\times 3000$ . Fig. 6.23. Normal male. Fig. 6.24. 20-day castrate. Fig. 6.25. 20-day castrate injected with testis extract. Fig. 6.26. Normal male; photomicrograph  $\times 1000$ ; Mann-Kopsch preparation for Golgi apparatus. (From C. R. Moore, D. Price and T. F. Gallagher, *Am. J. Anat.*, **45**, 71-107, 1930.)

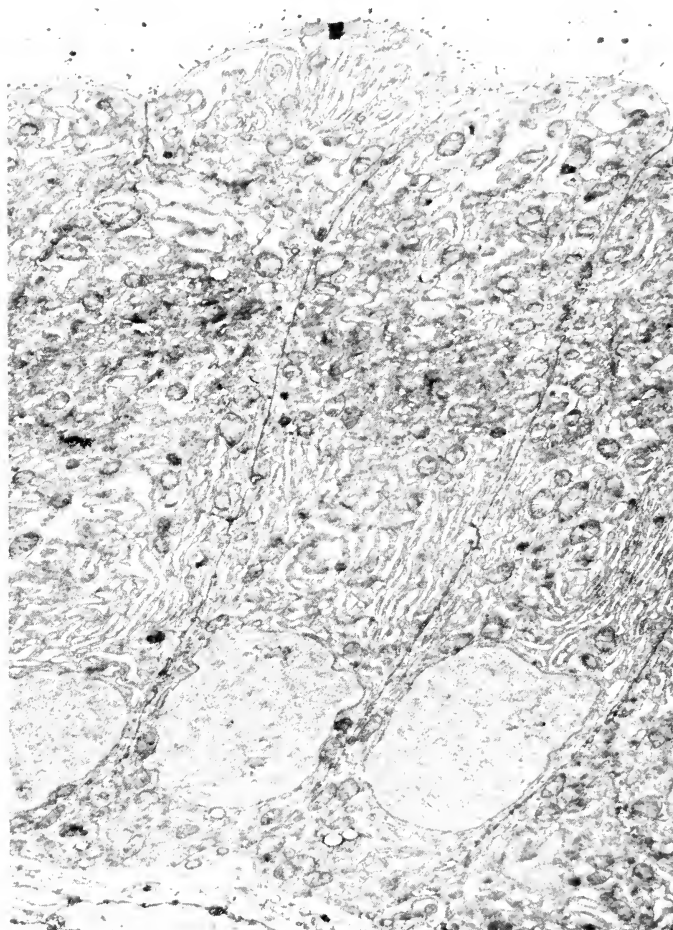

FIG. 6.27. Rat ventral prostate, normal male. Electronmicrograph  $\times 8500$ ; Luff's permanganate fixative. Microvilli extend as prolongations of the cytoplasm into the lumen; a major part of the cytoplasm is a labyrinth of ergastoplasmic sacs with scattered mitochondria; nuclei are basal; half-way between nucleus and cell apex is a zone of small vesicles and canals, the Golgi complex (From J. C. Harkin, unpublished.)

stained area in the apical cytoplasm was not clear. Rixon and Whitfield (1959) reported high concentrations of zinc in the apical cytoplasm, nucleoli, and stroma in fixed tissues stained with dithizone. In the apical cytoplasm, the zinc is concentrated at the tip of the cells in a "luminal border organelle" which is osmiophilic (distinct from the Golgi apparatus), argentophilic,

and basophilic. Nucleoli and subepithelial stroma are basophilic.

Castration results in a typical pattern of involution in the epithelial cells: size is reduced, nuclei become small and pyknotic, and changes occur in the density of the cytoplasm (Korenechevsky and Dennison, 1935; Price, Mann and Lutwak-Mann, 1955). The zinc content of the gland (dor-



solateral or lateral prostate) and the rate of  $Zn^{65}$  uptake decrease after gonadectomy as does the secretion of citric acid and fructose (see Section II).

*Dorsal prostate.* The epithelium in the dorsal prostate of normal rats is columnar or cuboidal depending on distention of the alveoli; nuclei are basal and stain heavily; there is cytoplasmic vacuolization which is usually limited to the basal region (Korenchevsky and Dennison, 1935).

Brandes and Groth (1961) described the ultrastructure of two different cell types in the dorsolateral (or dorsal) lobe. These types differ in the relation of cytoplasmic matrix to endoplasmic reticulum. In both, the matrix is moderately homogeneous and

contains small particles, but in cell type 1, the matrix appears as separate profiles and the reticulum as membrane-bounded individual cavities. In cell type 2, the reticulum forms dilated membrane-bounded cisternae which are intercommunicating and the cytoplasmic matrix is reduced mainly to thin strands appearing isolated within the cisternae.

Gunn and Gould (1956a) reported a zinc-negative histochemical reaction in the epithelium of the dorsal prostate. Fleischhauer (1957) observed a slight dithionite-stain macroscopically, and in unfixed frozen sections, individual groups of cells contain the distinctive basal zinc-positive granules that are characteristic of all epithelial cells

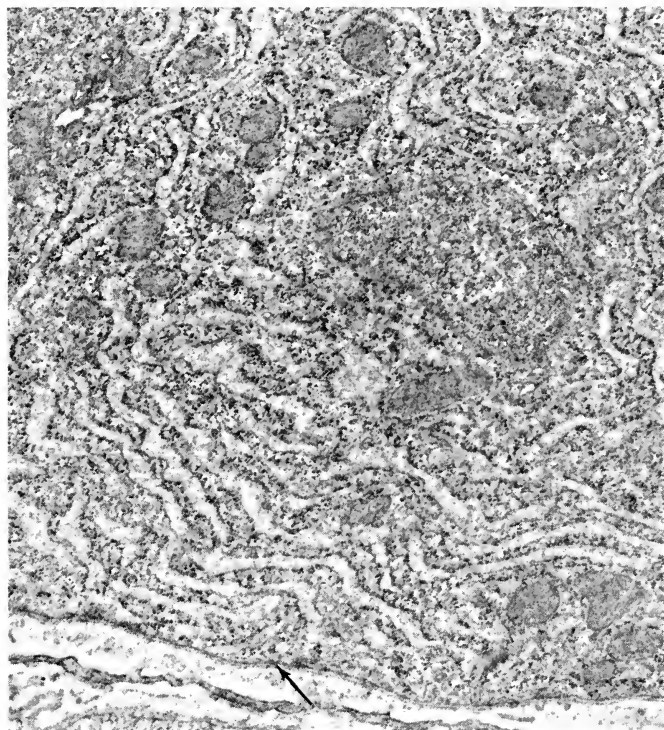

FIG. 628. Rat ventral prostate, normal male. Electronmicrograph  $\times 26,000$ ; Dalton's chrome osmic acid fixative. Basal part of epithelial cell to show the character of the granular component and ergastoplasmic sacs which are essentially equal in amount in this region. Double basement membrane indicated by arrow. (From J. C. Harkin, *Endocrinology*, 60: 185-199, 1957.)

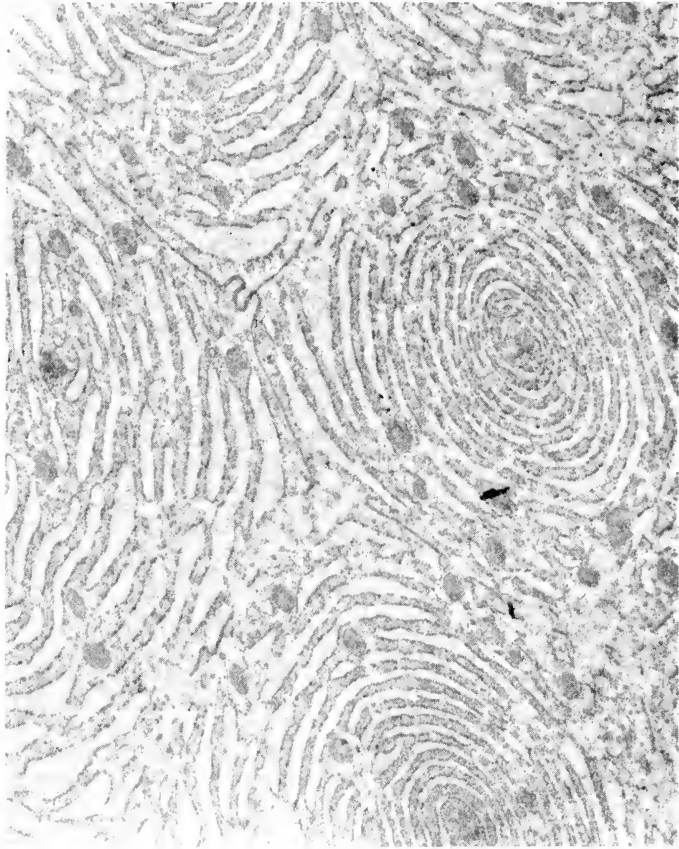

FIG. 6.29. Rat ventral prostate, normal male. Electronmicrograph  $\times 48,000$ ; Palade's osmic acid fixative with sucrose. Supranuclear region of epithelial cell showing lamellated cisternae. (From J. C. Harkin, unpublished.)

in the lateral lobe. There is no diffuse staining of the apical cytoplasm. Nucleoli are intensely zinc-positive after fixation and staining with dithionite; nucleoli, apical cytoplasm and stroma are basophilic (Rixon and Whitfield, 1959). The stroma is also strongly alkaline phosphatase-positive (Bern, 1949a).

Epithelial cells respond to castration by reduction in cell and nuclear size, and loss of granulation in the cytoplasm (Korenchevsky and Dennison, 1935). Brandes and Portela (1960a) observed in electron micrographs the beginning of collapse of the

cisternae of the endoplasmic reticulum, reduction in RNA-rich particles, and changes in mitochondria. Histochemical studies (Bern and Levy, 1952) indicate that distribution of alkaline phosphatase activity remains unchanged. Fructose content is reduced in the gland after castration (Price, Mann and Lutwak-Mann, 1955).

*Coagulating gland (anterior prostate).* In normal males, the epithelium is columnar and rests on a well marked basement membrane; nuclei stain heavily and homogeneously and are situated midway between the basement membrane and lumen. The cyto-

plasm is not as granular as in the ventral prostate and appears vacuolated, particularly in the basal region and around the nuclei; the apical cytoplasm is condensed and granular (Fig. 6.13, a gland from a castrated male injected with testicular extract, illustrates essentially the characteristics of the normal epithelium). Golgi bodies (Fig. 6.26) form large networks close to the

luminal end of the cells (Moore, Price and Gallagher, 1930).

The striking characteristic of these cells in electron microscopy (Brandes, Belt and Bourne, 1959; Brandes and Groth, 1961) is the great dilation of the cisternae of the endoplasmic reticulum (Fig. 6.31) which fill the greatest part of the cell and are particularly distended in the basal region. The

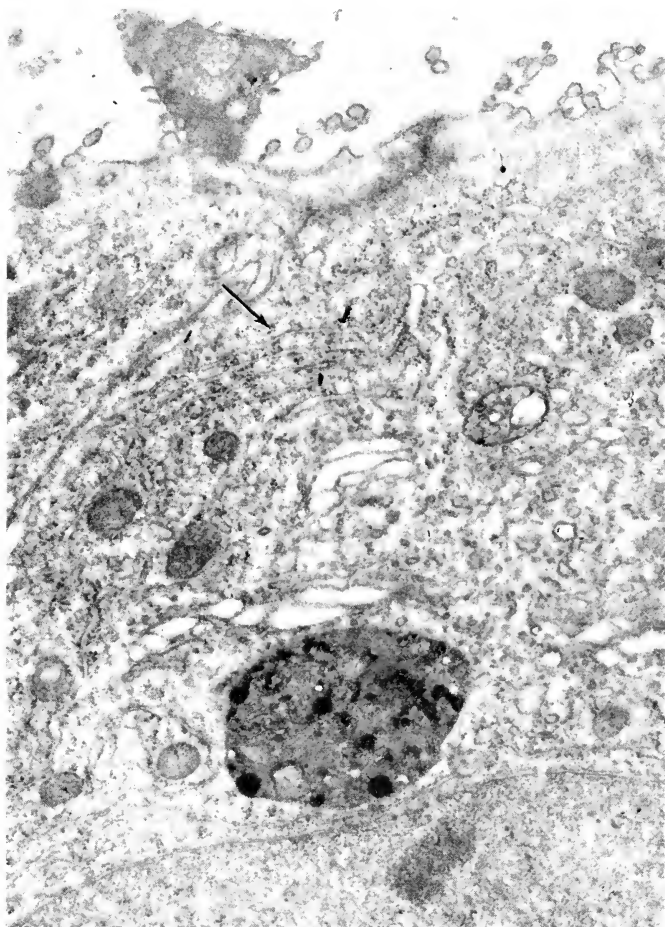

FIG. 6.30. Rat ventral prostate, 4-day castrate. Electronmicrograph  $\times 26,000$ ; Dalton's chrome osmic acid fixative. Portion of nucleus and distal region of epithelial cell. An electron dense body lies above the nucleus and below dilated Golgi microvesicles. Arrow points to collapsed ergastoplasmic sacs. (From J. C. Harkin, *Endocrinology*, **60**, 185-199, 1957.)

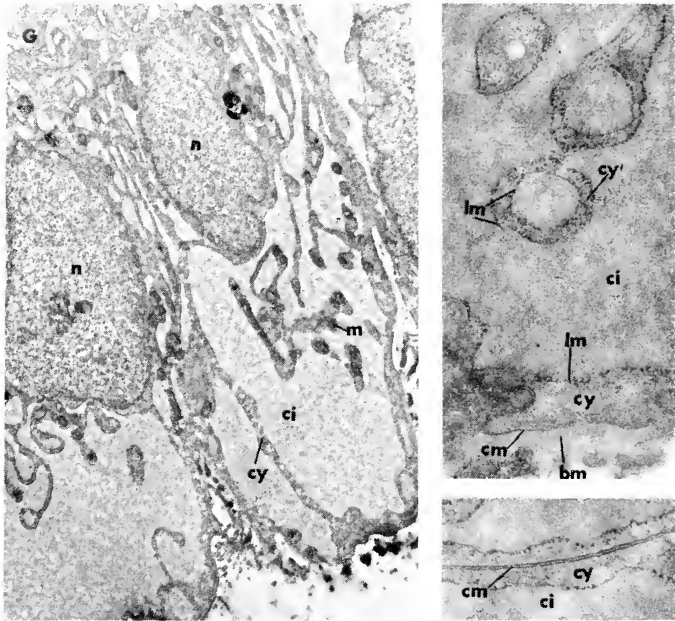

FIG. 6.31. Rat coagulating gland, normal male. Electronmicrographs, left  $\times 7200$ ; upper and lower right  $\times 39,000$ . Caulfield's modification of Palade's osmic acid fixative. Left, basal portions of two epithelial cells; right, details of basal region: *bm*, basement membrane; *ci*, dilated cisternae; *cm*, plasma membrane; *cy*, cytoplasmic matrix; *G*, Golgi complex; *lm*, limiting membrane of endoplasmic reticulum; *m*, mitochondria; *n*, nucleus. (From D. Brandes, unpublished.)

cytoplasmic matrix appears as strands within the cisternae. The Golgi complex is represented by parallel rows of membranes, vacuoles, and smaller vesicles.

Histochemically (Table 6.6), the secretion is intensely PAS-positive and the cytoplasm is slightly reactive (Leblond, 1950). The stroma is strongly alkaline phosphatase-positive (Bern, 1949a).

The effects of castration are not apparent by light microscopy as early as in the ventral prostate and seminal vesicles. At 10 days after castration the cells are slightly smaller and the cytoplasm less dense; by 20 days, the cells are markedly reduced in size, nuclei smaller, cytoplasm clear, basement membrane absent or less well defined (Figs. 6.12 and 6.24). The Golgi apparatus is reduced in amount but not fragmented. It still retains the shape of strands or threads which cap around the nucleus at

90 days of castration but the mass is reduced (Moore, Price and Gallagher, 1930).

Brandes and Portela (1960a) state that castration produces gradual and slow collapse of cisternae in the endoplasmic reticulum, changes in mitochondria, and reduction and loss of RNA-rich particles from the membranes. Studies of functional activity show that the ability to secrete fructose and vesiculase is lost (see Section II).

Depending on the length of the interval between the operation and administration of the hormone, treatment of castrates with testis extracts (Figs. 6.13 and 6.25) or testosterone prevents or repairs histologic and functional changes.

*Seminal vesicles.* The secretory epithelium is columnar in normal males; nuclei are basal and contain one or two conspicuous nucleoli and smaller chromatin masses (Table 6.7). Secretion granules, surrounded

TABLE 6.7

Summary of the effects of testicular androgen on rat and mouse seminal vesicles

Normal Males	Castrated Males
General Characteristics	
<b>Rat and mouse</b> <i>mucosa</i> folded; acidophilic secretion in lumen <i>columnar epithelial cells</i> ; secretion granules supranuclear... <i>Golgi</i> supranuclear networks... <i>mitochondria</i> as rods or granules <i>nuclei</i> basal; <i>nucleoli</i> prominent <i>stroma</i> of connective tissue and smooth muscle	Villous folding reduced; secretion greatly reduced Cell size reduced; granules lost Reduced in volume; fragmented Apparently reduced in relative numbers (rat) Nuclei shrunken and pyknotic; nucleoli disappear Amount appears increased
Specific Characteristics	
<b>Rat</b> Histochemical observations: <i>secretion</i> in lumen PAS-positive, intensity variable; acidophilic <i>cytoplasm</i> slight PAS reaction; strongly acid phosphatase-positive; strongly basophilic <i>secretion granules</i> in epithelium strongly acid phosphatase-positive <i>nuclei</i> strong acid phosphatase reaction... <i>stroma</i> slight PAS reaction; acid phosphatase-positive; strong alkaline phosphatase reaction	Phosphatase activity reduced Slight basophilia Activity lost Remained weakly acid phosphatase-positive Acid and alkaline phosphatase activity reduced
<b>Mouse</b> Histochemical observations: <i>secretion</i> in lumen moderately PAS-positive and acidophilic <i>cytoplasm</i> moderately basophilic at base and lateral margins of cells; apical granules acid phosphatase-positive <i>secretion granules</i> in epithelium weakly PAS-positive and acidophilic... <i>Golgi</i> region; granules PAS-positive and acidophilic <i>stroma</i> intensely PAS- and alkaline phosphatase-positive Electron microscopic observations: <i>cytoplasm</i> complex pattern of basal and lateral ergastoplasmic mem- branes; abundant RNA-rich granules... <i>Golgi</i> region; parallel arrays of smooth-surfaced membranes and vesicles	Secretory granules less acidophilic Weakly basophilic Reduced in number; less acidophilic Phosphatase activity reduced Ergastoplasmic channels less distended and con- torted Relative number reduced

by vesicular zones are present in the supra-nuclear region (Fig. 6.36) and resemble the secretion in the lumen in staining reactions. The Golgi complex appears in osmium preparations as irregular networks or a vesicular structure (Fig. 6.32); the basement membrane is poorly defined or absent (Moore, Hughes and Gallagher, 1930).

The extracellular secretion is only slightly PAS-positive but varies in the intensity of reaction; there is little reaction in the epithelial cells except in some cells with stained granules; fibers of the lamina propria, smooth muscles, and walls of arterioles are weakly reactive (Leblond, 1950; Melampy and Cavazos, 1953). Stroma and capillaries are strongly alkaline phosphatase-positive (Bem, 1949a; Dempsey, Greep and Deane, 1949; Melampy and Cavazos, 1953). The cytoplasm, secretion granules, nuclei, and stroma give an intense acid phosphatase reaction; the cytoplasm is strongly baso-

philic and the reaction is abolished by ribonuclease (Melampy and Cavazos, 1953).

The response to castration is rapid. In 2 days the cells are reduced in height mainly by reduction in apical mass; secretion granules are few, small, and indistinct. By 10 days, cells are small, secretion granules are gone, nuclei are small with heavily staining chromatin (Fig. 6.35), and Golgi bodies have begun to fragment; at 20 days, these changes are more advanced and the remnant of the Golgi bodies (Fig. 6.33) occupies almost the entire supranuclear region (Moore, Hughes and Gallagher, 1930). In a cytometric study, Cavazos and Melampy (1954) found a statistically significant reduction in cell height by 6 hours after castration; by 48 hours many nucleoli are smaller than normal and by 60 hours most nucleoli are small; nuclear diameter is reduced but change more slowly.

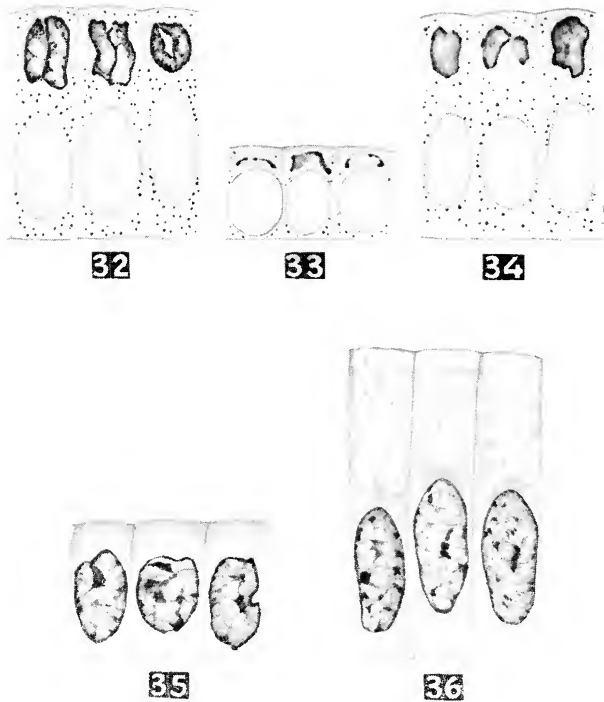

FIGS. 6.32-6.36. Rat seminal vesicle; camera lucida drawings  $\times 3000$ . FIGS. 6.32-6.34. Mamm-Kopsch preparations for Golgi apparatus. FIG. 6.32. Normal male. FIG. 6.33. 20-day castrate. FIG. 6.34. 20-day castrate injected with testis extract. FIG. 6.35. 10-day castrate. FIG. 6.36. 20-day castrate injected with testis extract. (From C. R. Moore, W. Hughes and T. F. Gallagher, *Am. J. Anat.*, **45**, 71-107, 1930.)

Gonadectomy causes gradual reduction and disappearance of alkaline phosphatase activity (Dempsey, Greep and Deane, 1949; Melampy and Cavazos, 1953) and hypophysectomy, with consequent diminution of testicular hormones, gives similar results (Dempsey, Greep and Deane, 1949). Bern and Levy (1952) reported some retention of alkaline phosphatase activity in the fibromuscular tissue of castrates. Acid phosphatase activity decreased within 10 days following castration (Melampy and Cavazos, 1953).

In early experiments (Moore, Hughes and Gallagher, 1930), administration of bull testis extracts to castrated rats maintained normal histologic structure or repaired involuational changes (Figs. 6.34 and 6.36),

and androsterone, testosterone, and testosterone propionate gave similar results (Moore and Price, 1937, 1938). Androgen treatment in castrates produced detectable changes within 2 days. Burkhart (1942) observed cell hypertrophy and enlargement of nuclei 23 hours after a single injection of testosterone propionate into 40-day castrates; mitotic activity began at 35 hours and reached a maximum at 43 hours. Cavazos and Melampy (1954) treated castrates with testosterone propionate and found increases in nuclear diameter within 12 hours, cell height within 24 hours, and nucleolar size by 36 hours; mitotic activity was evident at 48 hours. The same hormone restored normal alkaline and acid phosphatase activity in castrates within 10 days

(Dempsey, Creep and Deane, 1949; Melampy and Cavazos, 1953).

**MOUSE PROSTATE AND SEMINAL VESICLES.**  
*Ventral prostate.* The epithelial cells in the adult gland are low to moderately tall columnar; acini are surrounded by a thin fibromuscular layer; lumina contain finely granular, acidophilic secretion. The cytoplasm appears somewhat foamy with a clear zone in the supranuclear Golgi region and rather dense basophilia near the lumen (Franks, 1959). In appropriate histologic preparations, the Golgi apparatus is visible as a network in the apical cytoplasm close to the nucleus and the twisted strands are oriented parallel to the long axis of the cell (Horning, 1947).

Brandes and Portela (1960c) observed by electron microscopy an endoplasmic reticulum of cisternae or vesicles that are usually flattened but have dilations. RNA-rich granules are attached to the outer surface of the thin membranes bounding the vesicles and occur also in the cytoplasmic matrix; the arrangement of cisternae may be parallel or in a random pattern. The luminal margin of cells exhibits small cytoplasmic projections covered by the cell membrane. There are also extensions of the margin which appear similar to fragments of cytoplasm that seem to lie free in the lumen, and are presumably detached from the apical tips of cells. The lumina also contain structures that resemble profiles of the endoplasmic reticulum and mitochondria. The supranuclear Golgi complex consists of vacuoles of various sizes and flattened vesicles; endoplasmic reticulum and mitochondria are present in the Golgi zone.

Histochemical findings (Table 6.8) indicate alkaline phosphatase activity in the stroma with a positive reaction in the basement membrane, endothelium of blood vessels, and sheaths of smooth muscle fibers (Brandes and Bourne, 1954). With longer incubation periods of the tissue (Bern, 1949a), the epithelium and secretion in the lumina are strongly reactive and the stroma shows some activity. Brandes and Bourne (1954) reported acid phosphatase activity in the epithelium; the Golgi region gave the strongest reaction and the nuclei were moderately positive. Luminal secretion, ag-

gregations of granules in the Golgi region and apical cytoplasm, basement membranes, and capillary endothelium were PAS-positive. Sulfhydryl and disulfide reactions were moderately strong in epithelial cells and basement membranes.

Gonadectomy results in typical cell retrogression with reduction in cell height and nuclear size. Brandes and Bourne (1954) summarized their results as follows: after gonad removal, the Golgi apparatus showed some fragmentation and was not so dense by 12 to 14 days; alkaline phosphatase activity was slightly less intense by 4 days; changes in acid phosphatase activity in the Golgi region were evident by 4 days and marked by 21 to 22 days; the PAS reaction was reduced by 8 days and almost lost in the epithelium by 21 to 22 days. Subcutaneous implantation of pellets of testosterone propionate 13 to 32 days after castration produced a rapid return to normal of Golgi apparatus and phosphatase activity and a gradual recovery of normal PAS reactions. Allen (1958) reported a significant increase in mitotic activity in the epithelium of 30-day castrates within 30 to 36 hours following a single injection of 16  $\mu$ g. of testosterone propionate; peak activity was reached in 42 to 48 hours.

*Dorsal prostate.* The epithelial cells resemble rather closely those of the coagulating gland but the cytoplasm is more granular, the centrally placed nuclei darker, and the Golgi apparatus in the apical cytoplasm (in close contact with the nucleus) is less dense than the Golgi networks in the coagulating gland (Horning, 1947). Histochemically, the distribution of phosphatase activities and PAS reaction in normal males, castrates, and castrates treated with testosterone propionate are similar to the findings in the coagulating gland (Bern, 1949a, 1951; Brandes and Bourne, 1954).

*Coagulating gland (anterior prostate).* The secretory cells are columnar and the nuclei are approximately midway between basement membrane and lumen. The cytoplasm is granular and the condensed Golgi apparatus is a flattened network oriented transversely in the most apical region of the cytoplasm (Horning, 1947).

Electron microscopic studies by Brandes

TABLE 6.8

Summary of the effects of testicular androgen on the mouse prostate and coagulating glands

Normal Males	Castrated Males
General Characteristics	
All lobes	
<i>alveoli</i> with folded mucosa; secretion in lumina.	Reduction in alveolar size; loss of villi and bulk of secretion
<i>columnar epithelial cells</i> .	Reduction in cell size; pseudostratification
<i>cytoplasm</i> of epithelial cells granular or foamy.	Appears less dense
<i>nuclei</i> basal....	Shrunken and pyknotic
<i>stroma</i> of connective tissue and smooth muscle	Fibromuscular increase
Histochemical observations:	
<i>secretion</i> in lumina PAS-positive....	Almost completely negative
<i>cytoplasm</i> acid phosphatase-positive; sulfhydryl reaction.	Phosphatase activity reduced
<i>intracytoplasmic granules</i> PAS-positive; near luminal border....	Almost completely negative
<i>Golgi</i> region PAS-positive granules; strong acid phosphatase activity.	Almost completely negative
<i>basement membrane</i> PAS- and alkaline phosphatase-positive..	Activity retained; less intense
<i>Stroma</i> PAS- and alkaline phosphatase-positive	Activity retained in sheaths of smooth muscles
Electron microscopic observations:	
<i>epithelial cells</i> with microvilli.	Cell size reduced
<i>Golgi complex</i> smooth surfaced membranes and vesicles	
Specific Characteristics	
Ventral lobes	
Histochemical observations:	
<i>secretion</i> in lumina strong alkaline phosphatase activity	
<i>cytoplasm</i> alkaline phosphatase-positive	
<i>Golgi</i> loose networks in apical cytoplasm	Reduced in amount; fragmented
Electron microscopic observations:	
<i>cytoplasm</i> ; ergastoplasm with generally flattened cisternae..	Cisternae collapsed; reduced granules
Dorsal lobes	
Histochemical observations:	
<i>Golgi</i> compact networks in apical cytoplasm....	Reduced in amount; fragmented
Coagulating glands (anterior prostate)	
Histochemical observations:	
<i>Secretion</i> in lumina intense protein reaction; PAS-positive;... sulfhydryl reaction	Some PAS reaction retained Sulfhydryl reaction lost
<i>cytoplasm</i> high concentrations of RNA basally and apically. protein reactions, intense apically	Markedly decreased Greatly reduced
sulfhydryl reaction, especially strong apically	Reaction lost
<i>Golgi</i> condensed apical networks ...	Reduced in amount; fragmented
Electron microscopic observations:	
<i>cytoplasm</i> extremely dilated ergastoplasmic cisternae	Cisternae collapsed; granules reduced

and Portela (1960b) show that these epithelial cells are characterized by an endoplasmic reticulum with greatly dilated cisternae. This dilation is more marked in the middle of the cell and in the basal region (Fig. 6.37) where the dilated cisternae appear as intercommunicating channels in which the cytoplasmic matrix forms isolated profiles or strands containing mitochondria and other organelles. The matrix is more abundant in the Golgi region and protrudes from the luminal margin of the cells as microprojections covered by the cell membrane.

Alkaline phosphatase activity is localized in the stroma (Bern, 1949a, 1951; Brandes

and Bourne, 1954; Bern, Alfert and Blair, 1957); acid phosphatase activity (Brandes and Bourne, 1954) is found in the epithelium and is particularly strong in the Golgi zone. Brandes and Bourne (1954) and Bern, Alfert and Blair (1957) reported PAS-positive reactions in the epithelial cells in the Golgi region and apical cytoplasm, and intense reactions in luminal secretion, basement membrane, and stroma. Sulfhydryl and disulfide reactions are evident in luminal secretion, epithelium (especially in the apical region), basement membrane, and fibromuscular tissue. The reactions are stronger than in the ventral prostate. Bern, Alfert and Blair (1957) found high con-





FIG. 6.37. Mouse coagulating gland, normal male. Electronmicrograph  $\times 39,000$ . Caulfield's modification of Palade's osmic acid fixative. Basal portion of an epithelial cell; insert, details of basement membrane region: *bm*, basement membrane; *ci*, dilated cisternae; *cm*, plasma or cell membrane; *cy*, cytoplasmic matrix; *m*, mitochondrion; *n*, nucleus. (From D. Brandes, unpublished.)

centrations of RNA basally and apically in the epithelial cells. Strong protein reactions are present in luminal secretion and apical regions of the cells.

The response to gonadectomy (Brandes and Bourne, 1954) includes reduction of alkaline and acid phosphatase activity within 4 days, PAS reactions by 8 days, and slight

fragmentation and loss of density of the Golgi apparatus by 12 to 14 days. Changes are more marked after longer periods of castration (Table 6.8), although Bern (1951) observed retention of stromal alkaline phosphatase for long periods. RNA concentrations in the cell (Bern, Allen, Blair, 1957) are greatly decreased by

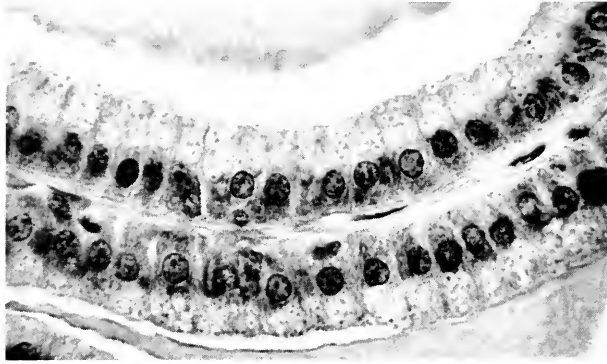

Fig. 6.38. Mouse seminal vesicle, normal male. Photomicrograph  $\times 750$ . Bouin-hematoxylin preparation. (From E. Howard, *Am. J. Anat.*, **65**, 105-149, 1939.)

accumulation remains in the apical region. The sulfhydryl reaction is partially lost but the cells retain apical reactivity.

Testosterone propionate implanted subcutaneously 13 to 32 days after testis removal (Brandes and Bourne, 1954) rapidly restored the Golgi apparatus and enzyme activity to normal, and the PAS reaction returned gradually. Allen (1958) showed that the epithelium of 30-day castrates responds to a single injection of 16  $\mu\text{g}$ . of testosterone propionate by an increase in mitotic activity within 30 to 36 hours.

*Seminal vesicles.* The epithelial cells in adult glands are columnar with basal nuclei and secretory granules surrounded by halos in the supranuclear cytoplasm (Fig. 6.35); the epithelium rests on a layer of smooth muscle and connective tissue stroma (Howard, 1939).

In electron micrographs (Deane and Porter, 1959), it can be seen that the surface membranes of secretory cells have microvilli which extend into the lumen. The supranuclear region contains secretory granules enclosed in vesicles or cisternae, smaller membrane-bound vesicles, and parallel arrays of smooth Golgi membranes. Moderately distended ergastoplasmic channels with membranes studded with presumed ribonucleoprotein particles form complex convolutions along the lateral margins and at the base of cells. The nucleus possesses clumped chromatin along the membrane (Figs. 6.39, 6.42, and 6.43). Fu-

jita (1959) described essentially the same type of endoplasmic reticulum and the presence of microvilli and secretion granules. In addition, small granules in the Golgi region were interpreted as precursors of secretory granules.

Histochemical preparations (Table 6.7) show strong alkaline phosphatase activity in stromal elements (Atkinson, 1948; Bern, 1951); acid phosphatase activity is present in the apical or Golgi region of the epithelial cells (Deane and Dempsey, 1945). Secretory material and secretory granules in the lumen and cytoplasm are acidophilic and weakly PAS-positive, whereas the reticulum in the lamina propria is intensely PAS reactive (Fig. 6.44). Lateral margins and basal regions of the cells (Fig. 6.45) are moderately basophilic (Deane and Porter, 1959).

Following castration of adult mice, the secretory epithelium retrogresses with loss of secretion granules and reduction in cell height and nuclear size. Effects of gonadectomy may be retarded and not uniform in all cells (Howard, 1939), but changes within 5 days have been reported for cell and nuclear size (Martins and Rocha, 1929).

Electron microscopic and histochemical studies (Table 6.7) reveal marked changes within a week after gonad removal (Deane and Porter, 1959). Cell size is reduced, there are fewer secretory granules, ergastoplasmic channels are less distended and

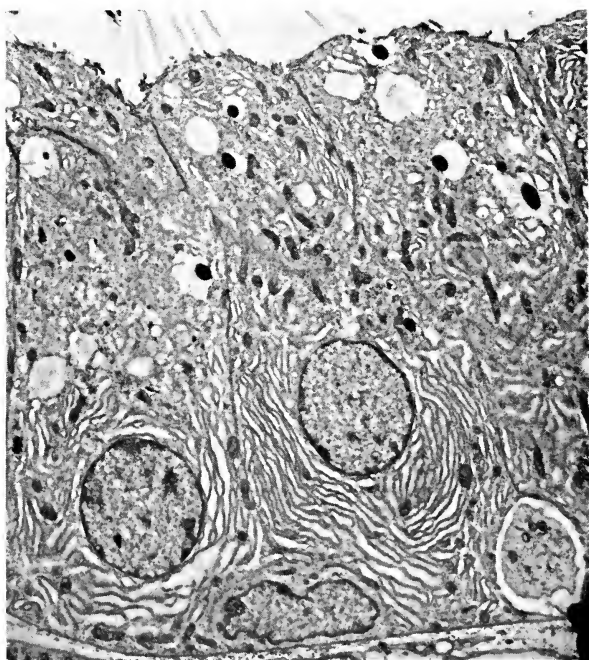

FIG. 6.39. Mouse seminal vesicle, normal male. Electronmicrograph  $\times 4200$ ; osmic acid fixation with sucrose. Epithelial cells showing basal and lateral ergastoplasmic channels and membranes, and supranuclear vesicles containing secretory granules. (From H. W. Deane and K. R. Porter, unpublished.)

convoluted (Fig. 6.40). The relative number of ribonucleoprotein particles is somewhat reduced, secretory granules are less acidophilic, and the cytoplasm is only weakly basophilic (Fig. 6.45). Secretion granules were still visible by electron microscopy 10 days after castration but they were not visible at 25 days (Fujita, 1959).

Atkinson (1948) found that alkaline phosphatase activity disappears almost completely from the stroma within 10 days, but Bern, Alfert and Blair (1957) observed retention in the fibromuscular tissue.

Martins and Rocha (1929) reported complete prevention of castration effects by injection of extracts of bull or goat testes. The epithelium of castrates responds readily to androgens. A single dose of 16  $\mu\text{g}$ . of testosterone propionate in 30-day castrates resulted in increased mitotic activity beginning 30 to 36 hours after treatment and

reached a peak at 42 to 48 hours (Allen, 1958). Administration of testosterone to castrates completely restored the fine structure to normal (Fujita, 1959). Alkaline phosphatase activity in the stroma returned to normal within 10 days with testosterone propionate administration (Atkinson, 1948). The same hormone given to normal males for one week resulted in increased cell height, more abundant and acidophilic secretion and secretory granules, increased basophilia (Fig. 6.45), more distended and convoluted ergastoplasmic channels (Fig. 6.41), and a relative increase in ribonucleoprotein particles (Deane and Porter, 1959).

DISCUSSION. The secretory cells in the epithelia of rat and mouse prostatic lobes and seminal vesicles have many histological characteristics in common and some marked dissimilarities. In light microscopy

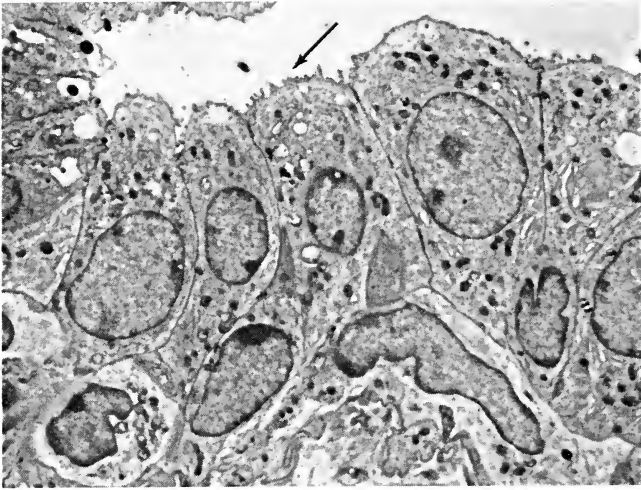

FIG. 6.40. Mouse seminal vesicle, 7-day castrate. Electronmicrograph  $\times 4200$ ; osmic acid fixation with sucrose. Note the reduction in cell height, number of secretory granules, and contortion of the ergastoplasmic membranes. Arrow indicates microvilli. (From H. W. Deane and K. R. Porter, unpublished.)

routine fixation and stains, the most obvious differences are in cell height, position and staining intensity of the nuclei, presence or absence of secretory granules, and in such cytoplasmic characteristics as the supranuclear clear zone in the rat ventral prostate and the basal vesicular region in the coagulating gland. The Golgi apparatus varies in density, structure, and position in the apical cytoplasm. Studies on ultrastructure reveal striking differences in the degree of dilation and the disposition of the endoplasmic reticulum. In the rat ventral prostate the most dilated cisternae are in the supranuclear region; in the dorsal lobe, generally distended vesicles are disposed throughout the cytoplasm in both cell types; in the coagulating gland, there is extreme dilation of the sacs, particularly in the basal region. The flattened vesicles of the mouse ventral prostate are disposed at random; the coagulating gland, like that of the rat, shows greatly dilated cisternae, especially basally. Moderately distended ergastoplasmic channels in the basal and lateral regions of cells are characteristic of the mouse seminal vesicles.

Changes following castration are detect-

able by light microscopy within 2 days in the rat seminal vesicle; 4 days in the ventral prostate; 10 days in the coagulating gland.

Harkin (1957a) suggested a correlation between distention of the sacs and secretory activity of the cells in the rat ventral prostate. Within 24 hours after gonadectomy, he observed dilation of the sacs, but within 2 days, collapse of the apical sacs was marked and by 4 days, there was general collapse of the vesicles in other regions of the endoplasmic reticulum. At this stage secretory activity of the cells was apparently reduced.

Brandes and Portela (1960a, b, c) discussed the relation of the cisternae to secretion in the mouse glands. They proposed that the extremely dilated cisternae of the coagulating glands contain secretory products which are released into the lumina of acini by some undetermined mechanism. They found no evidence that the Golgi complex is involved in the elaboration of secretory material in the cisternae, but histochemical findings suggest that it might take part in formation of secretory products that are not intracisternal. The ventral prostate

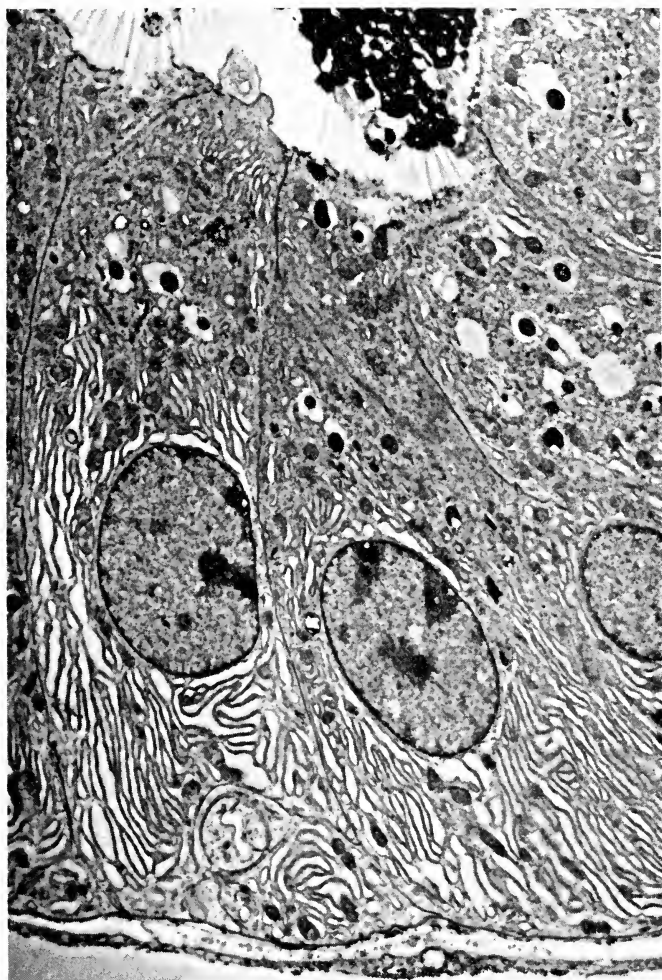

FIG. 6.41. Mouse seminal vesicle, intact male treated with testosterone propionate for 7 days. Electron micrograph  $\times 4200$ ; osmic acid fixation with sucrose. Note increase in cell height, abundance of secretory granules and contortion of the ergastoplasmic membranes. (From H. W. Deane and K. R. Porter, unpublished.)

is characterized by flattened vesicles. Brandes and Portela doubted that there is transport of secretory material to these cisternae and release from the intracisternal spaces into the acinar lumen. They suggested an apocrine type of release involving extrusion of portions of the apical cytoplasm from the

free margin of cells. The possibility of implication of the Golgi apparatus in the production of secretory material was considered.

From a study of the rat, Brandes and Groth (1961) concluded that the dilated cisternae of coagulating glands, dorsally

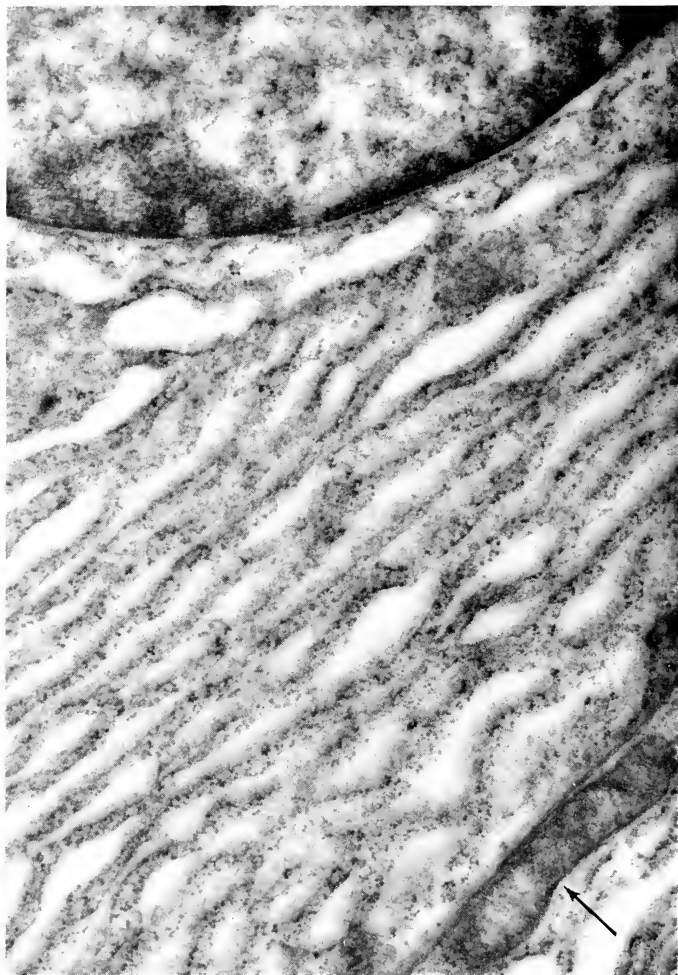

FIG. 6.12. Mouse seminal vesicle, normal male (same specimen as Fig. 6.36). Electron-micrograph  $\times 36,000$ ; osmic acid fixation; section treated with uranyl acetate to enhance the density of nucleoproteins. Infranuclear region of an epithelial cell; nucleus at the top; ergastoplasmic channels with membranes studded with particles; arrow indicates a mitochondrion. (From H. W. Deane and K. R. Porter, unpublished.)

eral and ventral prostates contain secretory products, and that it is probable that the membranes of the endoplasmic reticulum (or the granules associated with them) play an active role in the syntheses of the proteins present in the glandular secretions.

Attempts have been made to correlate

structure of cells as observed by light and electron microscopy with histochemical localizations of nucleoproteins (PAS reaction), alkaline and acid phosphatase activity, and basophilic material. Various interpretations have been offered for the functional significance of these substances, all of which

are under control of androgenic hormones of testicular origin. Leblond (1950) stated that the presence of PAS-positive granules in the Golgi region supports the concept of participation of the Golgi apparatus in the secretory process. Brandes and Portela (1960b) suggested that the vesicles and vacuoles in the Golgi zone might represent presecretory or secretory material. The possibility that collapse of ergastoplasmic sacs after gonadectomy might be correlated with reduction in PAS-positive secretory material was proposed by Harkin (1957a).

Alkaline and acid phosphatase activity is also found in the Golgi region, but the significance of this localization is not clear. Harkin (1957a) suggested that reduction in acid phosphatase activity following castration might be correlated with the decrease in numbers of mitochondria.

The histochemical pattern of enzyme activity has been discussed by Brandes and Bourne (1954), and the functional significance of distribution of epithelial and stromal alkaline phosphatase activity has been treated by Bern (1949a).

Cytoplasmic basophilia that was abolished by ribonuclease was demonstrated in the epithelial cells of the rat seminal vesicle (Melampy and Cavazos, 1953). In the mouse seminal vesicle, Deane and Porter (1959) found cytoplasmic basophilia (all of which was attributable to ribonucleic acid) localized in regions which corresponded to the distribution of ergastoplasmic membranes with their associated particles of presumed ribonucleoprotein. The relative number of particles was apparently reduced after one week of castration, and increased with testosterone propionate administration to normal males. These changes were not considered marked enough to account for the pronounced reduction in basophilia following gonadectomy, and the increase with androgenic hormone treatment of normal males.

Rixon and Whitfield (1959) found high concentrations of zinc, lipid, and basophilic material in a luminal border organelle in the lateral prostate of rats. Silver staining demonstrated fibrils, and it was suggested that zinc may be involved in the ergastoplasmic reticulum, possibly with lipopro-

tein, and would be associated with the microsome fraction in homogenates.

In the discussion of changes in structure and histochemical localizations of substances after gonadectomy and with hormone administration, no specific mention was made of differences in response among the glands. There are, however, pronounced differences in rate of regression following withdrawal of testicular hormone, and in rate and degree of response to administered androgen. These differences in hormone sensitivity or threshold have been established by such end points as changes in histologic structure, weight (which includes increase in mass of cells and accumulation and storage of secretion), and secretion of specific substances such as fructose and citric acid (Mann, 1954a). In order of sensitivity they are first, secretory function, second, histologic structure, and finally, weight, which is frequently used as an end point (Dorfman and Shipley, 1956).

Responsiveness of the epithelial cells depends on many factors and varies with specific glands, age of the animal, genetic strain, and species. A few examples will illustrate these points. Following castration of adult rats the seminal vesicles retrogress more rapidly than the ventral prostate and require higher doses of testosterone propionate to restore normal histological structure (Price, 1944a). The ability of the seminal vesicles and the ventral prostate in young rats to respond to testosterone propionate increases with age to a peak which is specific for the organ (Price and Ortiz, 1944; Price, 1947). This is true also for the female prostate (Price, 1944b) and the accessory glands in young male hamsters (Ortiz, 1947). The effect of age on responsiveness in the mouse ventral prostate was studied by Lasnitzki (1955a) who cultured glands from mice 4 to 6 weeks of age and 6 months old in normal control medium and in the presence of testosterone propionate. Young prostates regressed on the control medium but retained normal histologic structure when the hormone was added. In the control medium, older glands maintained normal structure and became hyperplastic with addition of the androgen. Franks (1959) also found differences

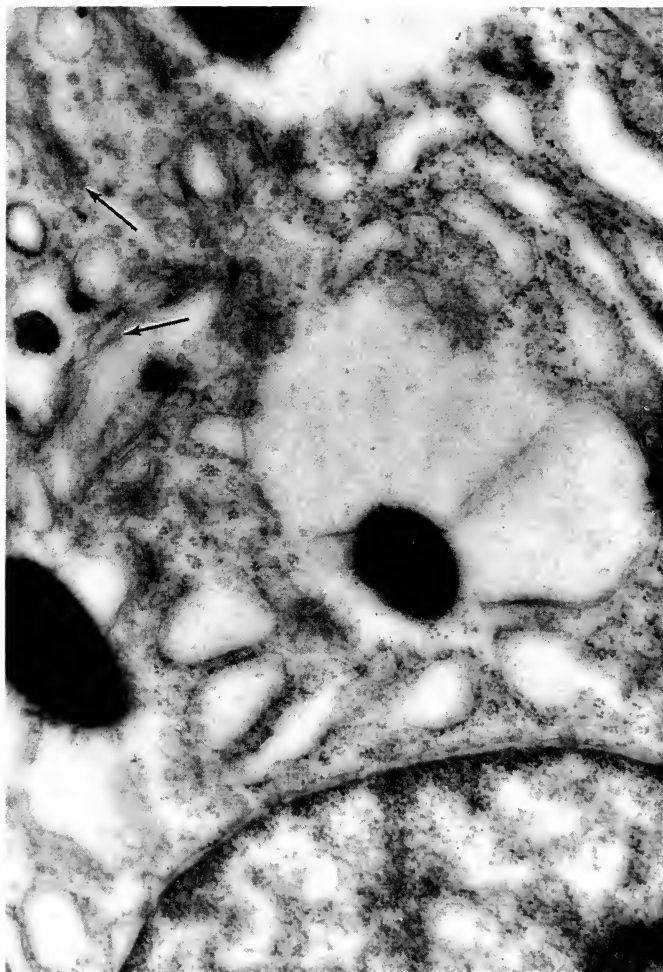

FIG. 6.B. Mouse seminal vesicle, normal male (same specimen, magnification, and preparation as Fig. 6.39). Supranuclear region of an epithelial cell; nucleus at the bottom; numerous membrane-bound vesicles with secretory granules in the larger vesicles; arrows indicate some of the parallel arrays of smooth-surfaced Golgi membranes. (From H. W. Deane and K. R. Porter, unpublished.)

lated to age in the response of cultured mouse ventral prostate to testosterone propionate. The Long-Evans and Sprague-Dawley strains of rats differ in responsiveness of the ventral prostate of adult hypophysectomized castrates to testosterone

propionate (Loströh and Li, 1956). Species differences in rate of retrogression of accessory glands in adult castrates are marked. As reported above, changes in histologic structure occur rapidly in rats, more slowly and less uniformly in mice (Howard, 1939),



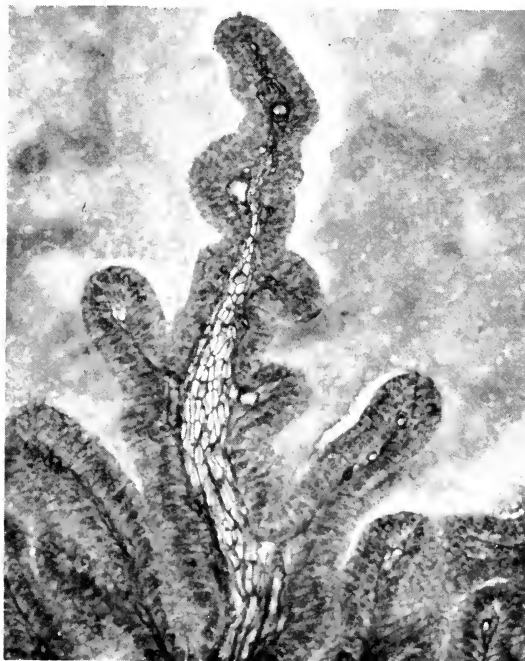

FIG. 6.44. Mouse seminal vesicle, normal male. Photomicrograph  $\times 250$ . Carnoy's fixative, stained by the periodic acid-Schiff method, counterstained with hematoxylin. Note the intense PAS-reaction in the reticulum in the lamina propria and surrounding the smooth muscle fibers; secretory material in the lumen is moderately reactive. (From H. W. Deane and K. R. Porter, unpublished.)

and slowly and somewhat incompletely in guinea pigs (Sayles, 1939, 1942) and hamsters (Ortiz, 1953). It should be noted that in adult castrated guinea pigs the ability to secrete fructose and citric acid is apparently lost in cells which show only partial retrogression histologically (Ortiz, Price, Williams-Ashman and Banks, 1956).

Another type of variation in responsiveness is demonstrated when weights of seminal vesicles and ventral prostates in immature castrated rats are used as end points for the potency of various  $C_{19}$  steroids (Dorfman and Shipley, 1956). When lower dosages of testosterone and  $17\alpha$ -methyl- $\Delta^5$ -androstene- $3\beta,17\beta$ -diol are given the ventral prostate is more responsive than the seminal vesicles, but at high dosage levels the percentage increase in seminal vesicle

weight equals or exceeds that of the prostate. Three other  $C_{19}$  steroids are far more effective on the ventral prostate than on seminal vesicles.

The female prostate in adult rats responds histologically and gravimetrically to a number of  $C_{19}$  steroids (Korenchevsky, 1937). These findings have been confirmed and extended by Huggins and Jensen (1954) and Huggins, Parsons and Jensen (1955) in hypophysectomized female rats. These workers examined the relation of molecular structure to the growth-promoting ability of the steroids.

Atrophy in male accessory glands of rats and mice has been reported under conditions of inanition and vitamin deficiency. These results are not usually attributable to reduction in responsiveness of the gland.

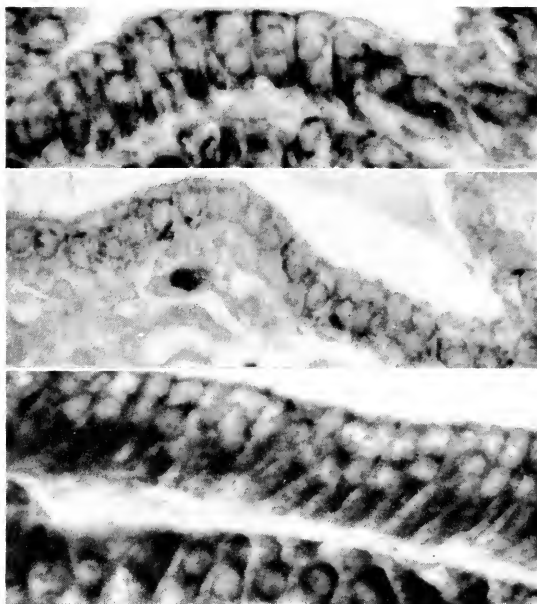

FIG. 6.45. Mouse seminal vesicles. Photomicrographs  $\times 700$ . Carnoy's fixative-methylene blue. Top, normal male; middle, 7-day castrate; bottom, intact male treated with testosterone propionate for 7 days. Basophilic material (ergastoplasm) occurs at the base and along lateral margins of cells; the Golgi zone appears clear; secretory granules are unstained. Basophilic material and Golgi zone are less evident after castration and more highly developed after testosterone treatment than normal. (From H. W. Deane and K. R. Porter, unpublished.)

themselves but to diminution in gonadotrophin titer by way of pituitary inhibition. Moore and Samuels (1931) showed that gonadotrophin or androgen treatment repaired the atrophied accessory glands in vitamin B-deficient rats and in those on limited food intake. Further, Lutwak-Mann and Mann (1950) demonstrated reduction of fructose and citric acid in accessory glands of rats on a vitamin B-deficient diet, but treatment with chorionic gonadotrophin not only restored the levels of these substances to normal but produced hypersecretion. Grayhack and Scott (1952) reported that the growth response to testosterone propionate of the ventral and posterior prostate in castrated rats on reduced food intake, vitamin-free casein, or glucose was little different from normally fed rats at lower dosages, but at higher levels there was less response in rats on limited dietary intake. Testosterone

propionate did not produce normal stimulation of the accessory glands in castrated mice on limited food intake (Goldsmith and Nigrelli, 1950). In adult rats, a folic acid antagonist (Aminopterin) partially prevented the reduction in prostatic weight produced by estradiol but did not interfere with testosterone stimulation of the prostate in castrated adults or intact immature animals (Brendler, 1949).

The senile changes which occur in advanced age in the prostate glands of the rat, mouse and of man have been described by Moore (1936) and interpreted on the basis of decrease in testicular androgen. Presenile variations in histologic structure are probably related to changes in responsiveness to androgens. In a brief report on electron microscopy (Harkin, 1957b), involutional changes in the rat ventral prostate were described. With increasing age,

electron-dense material is deposited in the Golgi region of epithelial cells and these bodies are said to resemble structures found in hyperplastic prostates in man.

## 2. Adrenal Androgens

A large body of evidence points to effects of hormones from the adrenal cortex on the accessory reproductive glands of male rats and mice and on prostate glands of female rats. The significance of this relationship is unknown and the effects are slight in many cases. Reviews by Parkes (1945), Ponce (1950), Courrier, Baelsse and Maurois (1953), Moore (1953) and Delost (1956) deal extensively with the subject. In man, a relationship between pathologies of the adrenal cortex and virilism is well recognized (Dorfman and Shipley, 1956).

The marked development of the ventral prostate in young castrated rats (Price, 1936) was attributed by Howard (1938) to the action of androgen from the adrenal cortex. The same explanation was suggested for the extensive development of the seminal vesicles and prostate in young castrated mice (Howard, 1939). The ventral prostate does not develop in immature castrated-adrenalectomized rats according to Burrill and Greene (1939a) and Howard (1941), but Gersh and Grollman (1939) did not confirm these findings. The impairment of prostate and seminal vesicle development in young castrated-adrenalectomized mice (Howard, 1946) was considered to be the result of poor physical condition rather than loss of adrenal androgen. Gonadectomy in young male mice of an inbred strain (Woolley and Little, 1945a, b) produced adrenal cortical carcinoma correlated with strong stimulation of the prostate and seminal vesicles. Spiegel (1939) castrated young guinea pigs and found the development of adrenal-cortical tumors and evidence of stimulation of prostates and seminal vesicles.

In the field vole (*Microtus arvalis* P.), Delost (1956) observed extensive development of the ventral prostate in young castrated males. Gonadectomy of adult males during the breeding season results in atrophy of seminal vesicles, and dorsal and lateral prostate, whereas the ventral prostate

shows an intense secretory activity by one month after testis removal. Adrenalectomy of castrates produces complete involution of the ventral prostate. Outside the breeding period, there is atrophy of all accessory glands except the ventral prostate which exhibits strong activation that can be prevented by adrenalectomy.

The prostate gland of young female rats undergoes development and differentiation, and resembles the male ventral prostate with which it is homologous (Price, 1939; Mahoney, 1940). Development still occurs following ovariectomy (Burrill and Greene, 1939b; Price, 1942) or adrenalectomy (Burrill and Greene, 1941), but not in ovariectomized-adrenalectomized females. A comparison of the responsiveness of female and male prostates indicated that the male gland is more sensitive to adrenal androgens (Price, 1942).

Autotransplants of adrenals into one seminal vesicle of adult castrated rats produced slight local stimulation of the gland and also androgenic effects on the other seminal vesicle and on the ventral prostate (Katsch, Gordon and Charipper, 1948). But androgenic action was local and barely discernible in somewhat similar experiments (Jost and Geloso, 1954). Price and Ingle (1957) autotransplanted adrenals into seminal vesicles and ventral prostates of adult castrates and observed definite but local stimulation of seminal vesicles, coagulating glands, and ventral prostates. Negative results of adrenal transplants in seminal vesicles of nonadrenalectomized rats were reported by Moore (1953). Takewaki (1954) failed to detect any androgenic effect of autotransplants of adrenals placed subcutaneously in contact with seminal vesicle grafts in castrated males.

The finding that treatment of young castrated male rats with adrenocorticotrophin caused stimulation of the ventral prostate (Davidson and Moon, 1936) has been confirmed by Deanesly (1960) who observed, in addition, a slight stimulation of the seminal vesicles. Nelson (1941) also found androgenic effects on accessory glands following ACTH treatment but Moore (1953), van der Laan (1953), and Takewaki (1954) obtained negative results. In hypophyse-

tomized-castrated rats, ACTH was reported ineffective in increasing ventral prostate weight (van der Laan, 1953; Grayhack, Bunce, Kearns and Scott, 1955), but Loströh and Li (1957) obtained some growth of ventral prostates and seminal vesicles at certain dosage levels. They emphasized that dosage is a critical factor in demonstrating the androgen-secreting ability of the adrenal cortex under ACTH stimulation. Administration of ACTH to hypophysectomized-castrated-adrenalectomized rats does not affect the accessory glands.

There has been no general agreement on the androgenicity of desoxycorticosterone on the accessory glands (see reviews by Parkes, 1945 and by Courrier, Baclesse and Marois, 1953). Loströh and Li (1957) reported that 11-desoxy-17-hydroxy-corticosterone and 11-dehydro-corticosterone displayed an androgenic activity equivalent to 4  $\mu$ g. of testosterone propionate on the ventral prostates and seminal vesicles of hypophysectomized-castrated adult rats. Corticosterone, cortisone, and hydrocortisone were ineffective. Grayhack, Bunce, Kearns and Scott (1955) found cortisone ineffective on the weight of ventral prostates in hypophysectomized castrates. In the field vole (*Microtus arvalis* P.), Delost (1956) produced effects on the ventral prostate by cortisone administration.

### 3. Ovarian Androgens

It has long been known that mammalian ovaries can secrete androgenic hormones which have virilizing effects in females. Discussion of the evidence for androgenic activity of the ovary has been presented by Ponce (1948) and Parkes (1950). More recently the subject has been extensively reviewed (Ponce, 1954b, 1955). Much of the interest in ovarian androgens in the rodent has centered on the question of their site of origin in the ovary and the effects of temperature and gonadotrophin administration on androgen production (see reviews, and Chapter 7 by Young). However, the use of male accessory glands as bio-indicators for ovarian androgen has contributed to our knowledge of the responsiveness of the glands.

Methods for approaching this problem include transplantation of ovaries into vari-

ous sites in castrated male rats and mice; placing ovarian autotransplants into the ears of females; transplantation of male accessory glands into females; and observations of prostate glands in females of the so-called female prostate strains of rats. The use of such females as hosts for grafts of male prostatic tissue has permitted a direct comparison of responsiveness in these homologous glands.

The first observations that ovarian grafts maintain normal prostates and seminal vesicles in castrated males were made in guinea pigs (Lipschütz, 1932) and mice (de Jongh and Korteweg, 1935). Hill (1937) transplanted ovaries into the ears of castrated male mice and obtained stimulation of the prostate and seminal vesicles. Deanesly (1938) reported similar findings in rats. Local effects from ovaries grafted into seminal vesicles of castrated rats were shown by Katsh (1950). Takewaki (1953) also found local stimulating effects on seminal vesicles when rat ovaries and seminal vesicles were transplanted close together into the spleens of gonadectomized males and females.

In experiments in which ventral prostates and seminal vesicles were transplanted subcutaneously into adult female rats (Price, 1941, 1942) it was shown that the ventral prostate is well maintained in virgin females (Fig. 6.46) and highly stimulated during pregnancy and lactation in the host. It is completely retrogressed in spayed females. Seminal vesicle grafts, however, are stimulated only rarely. This occurs only in females that have littered repeatedly and have been lactating for long periods. This indicates that the threshold of response of the ventral prostate to ovarian androgens is lower than that of the seminal vesicles. Evidence of functional stimulation with production of fructose and/or citric acid was obtained in coagulating glands, and ventral, lateral, and dorsal prostates transplanted into female rats in which the ovaries were stimulated by gonadotrophin treatment (Price, Mann and Lutwak-Mann, 1955). It may be assumed that the effects were attributable to ovarian androgens since ventral prostate grafts in spayed females (Greene and Burrill, 1939) are not stimulated histologically when gonado-

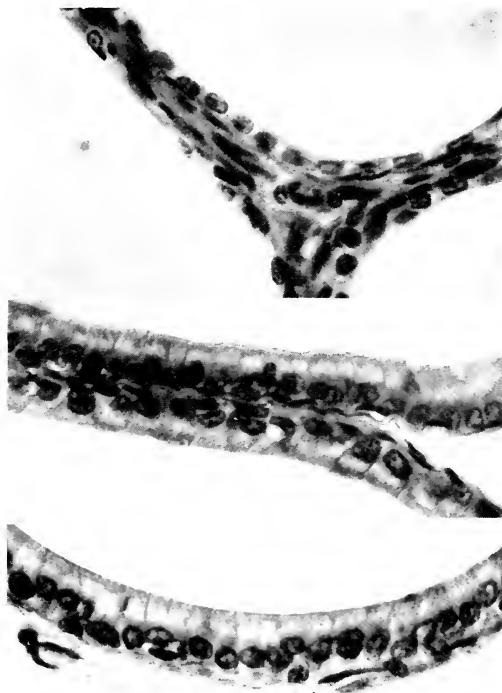

FIG. 6.46. Rat male and female prostates. Photomicrographs  $\times 650$ . Bouin-hematoxylin preparation. Top, host prostate from an adult virgin female; middle, male prostate graft from the above female host; bottom, prostate from a pregnant female. Note the semi-regressed epithelium in the female prostate of the virgin female host compared with the columnar epithelium and light areas in the male prostate graft and the prostate from a pregnant female. (From D. Price, *Anat. Rec.*, **82**, 93-113, 1942.)

trophin is administered. Great stimulation of ventral prostate grafts in the ovarian bursa of females was obtained by Ponce (1954a).

The female prostate gland is normally partially retrogressed in adult females except during pregnancy and lactation (Fig. 6.46) when it appears stimulated (Burrill and Greene, 1942; Price, 1942); in spayed females it is atrophic (Price, 1942). The striking development of the female prostate in pregnancy and lactation in a number of species of mammals is discussed in Section I. Hernandez (1942) obtained stimulation of female prostates by autotransplants of ovaries into ears, hind legs, or tails of rats.

Transplantation of rat ventral prostates into virgin females shows that the male

prostate has a lower threshold to ovarian androgens than the female gland and maintains high epithelium and cellular light areas whereas the epithelium of the host prostate (Fig. 6.46) is low and retrogressed (Price, 1942).

#### 4. Progesterone

The administration of progesterone in relatively enormous doses has stimulating effects as determined by weight, histologic structure, and function of some of the accessory glands in castrated male rats, mice, and guinea pigs. The literature has been reviewed by Greene, Burrill and Thomson (1940), Parkes (1950), and Price, Mann and Lutwak-Mann (1955).

Burkhart (1942) treated adult 40-day-

castrated rats with one or two 20-mg. doses of progesterone and observed a slight stimulation of mitotic activity in the ventral prostate and seminal vesicles after 55 hours but a pronounced hypertrophy of epithelium and connective tissue in both glands. The ventral prostate is more sensitive to progesterone than the seminal vesicles.

In castrated rats (Price, Mann and Lutwak-Mann, 1955), treatment with 25 mg. of progesterone daily stimulated the secretion of fructose or citric acid in seminal vesicles, coagulating glands, and ventral, lateral and dorsal prostates, and produced histologic changes in the last three glands. The effect, however, was only equivalent to that of about 5  $\mu$ g. of testosterone propionate. The lowest threshold to the hormone is in the ventral prostate and the highest in the seminal vesicles. Lostroh and Li (1957) found no effects of 0.5 mg. of progesterone daily on the ventral prostate and seminal vesicles of hypophysectomized-castrated adult rats, but the same dose of 17 $\alpha$ -hydroxyprogesterone was the androgenic equivalent of 4  $\mu$ g. of testosterone propionate. It may be noted that the following transformations are involved in the biosynthesis of testicular androgens: cholesterol  $\rightarrow$  pregnenolone  $\rightarrow$  progesterone  $\rightarrow$  17 $\alpha$ -hydroxyprogesterone  $\rightarrow$  androst-4-ene-3,17-dione  $\rightarrow$  testosterone (Dorfman, 1957). The slight androgenic actions of progesterone and 17 $\alpha$ -hydroxyprogesterone may result from their conversion to androstane derivatives by extragonadal tissues. The findings of Katsh (1950) that progesterone crystals implanted directly into the seminal vesicles of castrated rats have no stimulating influence may be significant in this regard.

### C. EFFECTS OF ESTROGENS

Administration of estrogenic hormones to normal males affects the accessory glands both indirectly and directly. The effects fall into three categories: inhibition as evidenced by weight changes, involution of the epithelium, and loss of secretory activity (attributable to inhibition of pituitary gonadotrophin and reduction in endogenous androgen); direct stimulation of fibromuscular tissue; and stimulation of hyperplasia and stratified squamous metaplasia of the

epithelium with possible keratinization. In no case does estrogen induce secretory activity of epithelial cells. The reduction in secretion as determined quantitatively (see Section II) may result from castration atrophy of secretory cells, or from hyperplastic and metaplastic transformations of the epithelium with resultant loss of normal secretory function.

The observed responses to estrogen treatment in glands of intact and castrated males, and in organ cultures of prostatic tissue, represent the dual effects of androgen withdrawal and estrogen addition. The extensive literature on the effects of estrogen and the evidence for so-called antagonistic, cooperative and synergistic effects of simultaneous administration of androgen and estrogen have been discussed extensively (Zuckerman, 1940; Emmens and Parkes, 1947; Ponce, 1948; Bern, 1949b; Burrows, 1949).

The observation that administration of estrogen to intact male rats causes atrophy of the accessory glands which is mediated by way of reduction of pituitary gonadotrophin and failure of secretion of testicular hormones was made by Moore and Price (1932). Estrogen-induced atrophy was prevented by simultaneous treatment with gonadotrophin or androgen. Direct stimulating effects were reported by Freud (1933) and David, Freud and de Jongh (1934) who observed fibromuscular growth in seminal vesicles of estrogen-treated castrated rats and stratification in the duct epithelium of the lateral prostate. Simultaneous treatment with androgen enhanced the hypertrophic effect of estrogen on the fibromuscular wall of the seminal vesicle but prevented epithelial change in the lateral prostate ducts. Korenchevsky and Dennison (1935) found estrogen stimulation of the muscular layer of the rat seminal vesicle with no effect on the epithelium, but in coagulating glands (and to a lesser degree in the dorsal prostate) there was not only fibromuscular hypertrophy but also metaplastic transformation of the epithelium with stratification; changes in the ventral and lateral lobes were slight and the epithelium was unaffected. Androgen treatment prevented the pathologic changes induced by estrogen. Harsh, Overholser and Wells

(1939) noted stratified, squamous epithelium in the ducts of the seminal vesicles, and ducts and acini of coagulating glands following estrogen administration. But a slight delay in castration atrophy and a weak stimulating effect of estrogen on seminal vesicle epithelium were observed by Overholser and Nelson (1935) and Lacassagne and Raynaud (1937).

Ovaries transplanted into castrated male rats (Pfeiffer, 1936) induce fibromuscular hypertrophy in host seminal vesicles and coagulating glands; stratified squamous cornified epithelium appears also in coagulating glands, and hyperplasia and metaplasia are present in lateral prostates. Estrogenic stimulation of fibromuscular tissue occurs (Price, 1941) in seminal vesicle grafts in normal female hosts but no such effects are evident in ventral prostate grafts.

Burkhart (1942) injected a single dose of estradiol benzoate into 40-day-castrated rats and observed no effect on the ventral prostate. But in the seminal vesicles, hypertrophy of epithelial cells occurred by 27 hours after treatment and by 55 hours, mitotic activity was evident in the epithelium and to some extent in the connective tissue.

In histochemical studies (Bern and Levy, 1952), metaplastic changes were observed in the seminal vesicle epithelium after estrogen treatment but no cornification occurred; the replacing epithelium was alkaline phosphatase-positive in contrast to the negative reaction in the original epithelium (Table 6.7). Fibromuscular hypertrophy was found but no definite alteration in enzyme concentrations except an absence of activity in edema of the subepithelial stroma. No metaplastic changes appeared in the coagulating gland epithelium, but the ducts of the dorsal prostate underwent metaplasia; alkaline phosphatase activity of the stroma in both glands was retained as in the castrate. The ventral prostate epithelium was atrophic but still enzyme-active after 120 days of treatment and the stroma reacted positively.

The effects of estrogen on the accessory glands of mice are far more marked than in rats. Long continued and strong doses of estrogen cause hyperplasia, metaplasia and

keratinization in the epithelium of mouse coagulating glands (Lacassagne, 1933). The same effects, with fibromuscular hypertrophy, were described in coagulating glands and prostates by Burrows and Kennaway (1934), Burrows (1935a), and de Jongh (1935) who prevented epithelial metaplasia in prostates by simultaneous treatment with androgen. Burrows (1935b) studied the localization of responses to estrogenic compounds and found that in order of time of response, the coagulating gland is first, seminal vesicles next, and finally the prostatic lobes. Changes begin in the urethral ends of ducts and progress peripherally into the acini. In the degree of response, the coagulating glands and seminal vesicles show the most drastic changes with the appearance of stratified, squamous, keratinizing epithelium and ultimate loss of acini. The effects on the lobes of the prostate include stratified, cornifying epithelium but the changes are not so pronounced. Some hypertrophy of fibromuscular stroma occurs in all the glands and hyperplasia is marked in the fibromuscular wall of the seminal vesicles.

Tislowitz (1939) found stimulation of mitotic activity in muscle and connective tissue of seminal vesicles and ventral prostate glands of immature castrated mice treated with estrogen. Stratification and cornification appear in the ventral prostate epithelium, with mitoses in the basal cell layers and also in seminal vesicle epithelium. Allen (1956) compared the mitogenic activity of a single dose of 16  $\mu$ g. of estradiol benzoate on seminal vesicles, coagulating glands, and ventral prostates of 30-day-castrated mice. Significant increases in mitotic activity occur in seminal vesicles and coagulating glands about 24 hours after treatment; the ventral prostate does not respond significantly until 72 hours and gives a low absolute value of mitoses.

Horning (1947) studied some of the initial changes in prostatic epithelium of intact mice receiving estrogen. Slight hypertrophy of epithelial cells and extensive fragmentation and dispersal of hypertrophied portions of the Golgi network occur by 8 days in the coagulating gland. At the same period, hypertrophic changes are less pronounced in the epithelium of the dorsal

prostate and there is only slight fragmentation of the Golgi apparatus. In the ventral prostate no epithelial hypertrophy is found but the Golgi network hypertrophies without fragmentation or dispersal. The ventral prostate is definitely less sensitive to estrogen than the other two glands.

After longer periods of estrogen administration, Bern (1951) observed fibromuscular hypertrophy of the seminal vesicle and intense alkaline phosphatase activity as in untreated intact males (Table 6.7); the epithelium, which is normally negative in enzyme activity, becomes positive and the beginning of metaplastic changes is occasionally visible. In the coagulating gland, stratified squamous metaplasia with masses of keratin is found and the metaplastic epithelium is strongly alkaline phosphatase-positive; enzyme activity is retained in the stroma but is variable. Bern, Alfert and Blair (1957) reported that the metaplastic coagulating gland epithelium is strongly alkaline phosphatase reactive, virtually PAS-negative, has dense homogeneous RNA concentrations decreasing in amount from base to lumen, and a dense homogeneous cytoplasmic protein reaction with a gradient of increasing intensity from base to lumen. The enlarged vesicular nuclei of the metaplastic epithelium have lower concentrations of deoxyribonucleic acid (DNA) than the nuclei of normal epithelial cells. The cytoplasm of these cells is as reactive as normal cells for sulfhydryl groups, and the newly formed keratin is intensely reactive; the greatest concentrations of disulfide groups are in superficial keratin.

In the dorsal prostate (Bern, 1951), estrogen causes fibromuscular hypertrophy with variable retention of alkaline phosphatase activity. Metaplastic changes involving basal cell proliferation and stratification begin and the metaplastic epithelium is intensely alkaline phosphatase active, a reversal of the normal reaction.

Brandes and Bourne (1954), using diethylstilbestrol, observed an increase in fibromuscular stroma in coagulating glands, dorsal and ventral prostates, and epithelial hyperplasia and stratification in varying degrees. The most pronounced changes occurred in the coagulating gland. The effects of estrogen on Golgi networks, and on PAS

and acid and alkaline phosphatase reactions are in general similar to the results of castration (Table 6.8).

Ventral prostate glands have been grown in culture by the watch glass method, with estrogens added to the medium. Lasnitzki (1954, 1958) reported hyperplasia and squamous metaplasia of the epithelium in young prostate tissue from C3H mice. In older glands, stimulation of fibromuscular tissue occurred. Franks (1959) using the C57 strain and a different culture medium observed no epithelial hyperplasia and metaplasia, but obtained increases in stroma and muscle. He attributed atrophic changes in the epithelium, which appear more marked in estrogen-treated than in control cultures, to direct inhibition by the hormone. Ventral prostate tissue from young mice is more sensitive to estrogen than tissue from adult or old males.

In the dog, Huggins and his collaborators demonstrated the effects of estrogen and combinations of estrogen and androgen on histologic structure and secretion in the prostate (see Section II). Estrogen causes decrease or increase in prostatic size depending on the dosage and on the levels of endogenous or exogenous androgen (Huggins and Clark, 1940). Squamous metaplasia of the epithelium of ducts and acini occurs with estrogen treatment, but only in the posterior lobe.

**DISCUSSION.** The results of estrogen administration to rats and mice vary with species, age of animal, specific gland under consideration, dosage, duration of treatment, and presence or absence of endogenous or exogenous androgen. Interpretation of the findings rests on the understanding that androgen directly stimulates mitotic and secretory activity in the epithelial cells. Estrogen inhibits pituitary function and thus reduces testicular androgen in intact males. It directly increases mitotic activity in the epithelium of the accessory glands, and induces epithelial hyperplasia and metaplasia, and fibromuscular hyperplasia. Whether the effects of simultaneous presence of androgen with exogenous estrogen are classified as protective, competitive (antagonistic), or cooperative (synergistic) on the accessory glands depends on the



relative levels of the two hormones. Both affect mitotic activity directly.

In a comparison of the effectiveness of androgen and estrogen on mitotic activity, Allen (1956, 1958) showed that a dose of 16  $\mu$ g. of testosterone propionate induces statistically significant increases in mitotic activity of the epithelium of seminal vesicles, coagulating glands and ventral prostates of castrated mice in 30 to 36 hours. The same dose of estradiol benzoate increases mitotic activity in 24 hours in seminal vesicles and coagulating glands, but not until 72 hours in ventral prostates.

Differences in responsiveness to estrogen are evident between rats and mice but in both species there is a gradient of reactivity with coagulating glands showing the most marked changes, seminal vesicles next, and prostatic lobes least. In glands of both species, the duct epithelium is more sensitive than acinar epithelium and the first observable effects are on urethral ends of ducts. Hyperplastic and metaplastic responses to estrogen occur also to varying degrees in accessory glands of other mammals—man, monkey, dog, cat, ground squirrel, and guinea pig. Zuckerman (1940) reviewed the effects of estrogen in male and female rodents and other mammals and suggested from the evidence that "stratified squamous proliferation or metaplasia is usually a primary response of tissue in whose development oestrogen-sensitive endodermal sinus epithelium has played a part."

On the basis of the pathologic effects of estrogen on the mouse coagulating glands and the protective action of androgen, several workers originally suggested that benign prostatic hypertrophy in man might result from a primary imbalance in the normal ratio of estrogenic to androgenic hormones in the male organism (Zuckerman, 1936). Further study has not supported this concept.

#### D. HORMONAL CONTROL OF SPONTANEOUS PROSTATIC NEOPLASMS

Spontaneous tumors of the prostate occur in rodents rarely if at all, but benign growths are extremely common in aging dogs and men, and prostatic cancer is a major problem in man. It is noteworthy that

neoplasms of the seminal vesicles in man are rare (Dixon and Moore, 1952).

#### 1. Benign Growths

In the dog, prostatic enlargement which is essentially due to cystic hyperplasia of the epithelium occurs in almost all senile males with functioning testes, but is not found in castrates (Huggins, 1947b). In these prostatic growths, which characteristically involve the entire gland, tall columnar secretory epithelium is always present in some acini. Canine prostatic hyperplasia is under control of testicular androgens (Huggins and Clark, 1940) and marked involution of these tumors as evidenced by their size and secretory activity (see Section II) can be induced by gonadectomy or treatment with suitable dosages of estrogen. Estrogen overdosage, however, causes prostatic enlargement and a metaplasia of the posterior lobe which does not resemble cystic hyperplasia. Huggins and Moulder (1945) reported that dogs feminized by estrogen-secreting Sertoli cell tumors of the testis do not have cystic hyperplasia. The important factors in this pathologic growth seem to be age and testicular androgens (Huggins, 1947b), but prolonged administration of testosterone propionate to aged castrate dogs results in normal-appearing prostates and not cystic hyperplasia.

Benign prostatic hypertrophy in man is rarely encountered before the age of 40 (Moore, 1943; Huggins, 1947b) but it is extremely common in old men. It differs markedly from prostatic hyperplasia in dogs; the lesions are limited to the medullary region of the prostate and are spheroidal neoplastic nodules involving, usually, both epithelium and fibromuscular tissue; other nodular types occur but are less frequent (Huggins, 1947b; Franks, 1954). The prostatic epithelium is composed of tall secretory cells (Huggins and Stevens, 1940). Despite the fact that castration may be followed by some shrinkage of hypertrophied human prostate tissue (White, 1893; Cabot, 1896; Huggins and Stevens, 1940), it is generally admitted that this treatment is of little value. Estrogen treatment results in changes in the acini of the inner or medullary (periurethral) part of the prostate, and stratification with squamous metaplasia

of the duct epithelium, but there is little effect on nodular stroma and acini (Huggins, 1947b). Since benign prostatic hypertrophy has not been observed in men castrated early in life, testicular androgen is presumably involved in its etiology (Huggins, 1947b). However, it is doubtful whether androgens are causative agents for this disease. Lesser, Vose and Dixey (1955) found that in men over the age of 45 who had received androgen treatment for non-cancerous conditions, the incidence of benign enlargement of the prostate was no greater than in untreated controls.

## 2. Prostatic Cancer

Prostatic cancer is a common disease in elderly men. This carcinoma, which characteristically arises in the posterior (outer) region of the prostate, consists of an abnormal growth of cells resembling adult prostatic epithelium rather than undifferentiated tissue (Huggins, Stevens and Hodges, 1941). It was found that these neoplasms are hormone-dependent and usually are influenced by anti-androgenic therapy; those which fail to respond are not adenocarcinomas with acini present in the tumor, but are undifferentiated carcinomas with solid masses of malignant cells (Huggins, 1942). However, the two types intergrade and both contain large amounts of acid phosphatase and are considered cancers of adult prostatic epithelium. The beneficial effects of castration or estrogenic treatment or both simultaneously, on metastatic carcinoma of the prostate in man were first demonstrated by Huggins and his collaborators (Huggins and Hodges, 1941; Huggins, Stevens and Hodges, 1941; Huggins, Scott and Hodges, 1941; Huggins, 1943, 1947a). This discovery was facilitated by the availability of a chemical index of the activity of the neoplasm, namely, the acid phosphatase activity of blood serum.

Although testosterone increases the level of serum acid phosphatase in patients with prostatic cancer (Huggins and Hodges, 1941; Sullivan, Gutman and Gutman, 1942), androgen treatment does not always exacerbate the growth of the tumor (Trunell and Duffy, 1950; Brendler, Chase and Scott, 1950; Brendler, 1956; Franks, 1958) or may even decrease it (Pearson, 1957). It is ques-

tionable if androgens induce prostatic cancer, inasmuch as their prolonged administration neither increases the incidence of this disease in man (Lesser, Vose and Dixey, 1955) nor induces it in dogs (Hertz, 1951).

The response of human metastasizing prostate cancer to anti-androgenic therapy is often very dramatic, but neither castration nor treatment with estrogens cures this disease. The tumor may regress for considerable periods of time, but eventually it recurs and begins to grow again. A small proportion of cases do not benefit at all (Huggins, 1957; Franks, 1958). Nevertheless, castration and/or estrogen therapy remain the best treatment for prostatic carcinoma in man (Nesbit and Baum, 1950; Huggins, 1956; O'Connor, Desautels, Pryor, Munson and Harrison, 1959).

Huggins and Scott (1945) suggested that the failure of some patients with prostatic cancer to obtain long lasting improvement from castration or estrogen treatment, or the two combined, lay in the secretion of androgenic substances by the adrenal glands. Early attempts to study the effect of bilateral adrenalectomy on human prostatic cancer were thwarted by the lack of suitable adrenal cortical steroids for adequate substitution therapy. But with the advent of cortisone, bilateral adrenalectomy could be accomplished with ease (Huggins and Bergenstal, 1951, 1952). It seems, however, that adrenalectomy is of limited value to patients with prostatic cancer in relapse after orchiectomy and/or treatment with estrogens (Whitmore, Randall, Pearson and West, 1954; Huggins, 1956; Fergusson, 1958).

## E. EFFECTS OF CERTAIN AROMATIC HYDROCARBONS (CARCINOGENS)

Spontaneous tumors have not been found in the prostate glands of rodents, but tumors can be induced in rats and mice by treatment with carcinogenic chemicals such as benzopyrene and methylcholanthrene. There has been considerable interest in inducing such tumors and studying their inception and growth, and the relation of steroid hormones to their development. Such investigations have contributed to an understanding of early neoplastic changes in the rodent prostate, but have had limited applicability

to the problem of hormonal control of prostatic cancer in man.

The first induction of prostatic cancer in rodents was accomplished by Moore and Melchionna (1937) who injected benzpyrene in lard directly into the rat anterior prostate (it should be noted that Moore and Melchionna used "anterior" in the sense of ventral as indicated by their histologic descriptions of a characteristic clear zone in the peripheral cytoplasm of the epithelial cells; this is typical only of the ventral lobe). The treatment was followed within 210 days by the development of squamous cell carcinomas in 72 per cent, and sarcomas in 5 per cent, of intact rats. Essentially similar results were obtained in an equivalent number of rats castrated at the time of carcinogen injection. Castration after tumors had developed did not cause atrophy of tumor cells. No metastases were found but there was anaplasia of cells and the tumors were invasive. The squamous metaplasia occurred in columnar secretory epithelium which was close to, or in contact with, benzpyrene cysts. The sequence of changes was reduction in cell height, loss of the clear area in the peripheral cytoplasm, pseudostratification, true stratification, development of intercellular bridges, and formation of keratohyaline. It was concluded that testicular androgen is not an important factor in the development of these squamous cell carcinomas, but on the basis of a small series of experimental animals it was suggested that exogenous androgen treatment in castrates may increase the incidence of sarcomas.

In 1946, Dunning, Curtis and Segaloff implanted compressed methyleholanthrene pellets into rat prostates (lobe not specified) and induced metastasizing squamous cell carcinomas. The tumors were transplantable and metastasized equally well in male and female hosts. Bern and Levy (1952) injected methyleholanthrene in lard into ventral prostates of intact Long-Evans rats and induced extensive neoplasms within 7 to 9 months. All but one were squamous cell carcinomas; the exception was a sarcoma. Quantitative determinations of enzyme activity showed a loss of alkaline phosphatase in cancerous prostates but no significant changes in acid phosphatase activity. Histo-

chemically, the stroma and capillaries were alkaline phosphatase reactive, but the carcinomas had virtually lost the strong alkaline phosphatase activity of the epithelium of origin (Table 6.2). There was some pseudo-reaction or reaction in sloughed keratin and necrotic areas.

Allen (1953) injected a suspension of methyleholanthrene in distilled water into ventral prostates or coagulating glands of intact and castrated rats. All were autopsied 180 days later. A high percentage of squamous cell carcinomas and a few sarcomas developed; metastases occurred in a few cases. There was no statistically significant difference between tumor incidence in the ventral prostate and coagulating gland. Tumors of the ventral prostate were found in 70.6 per cent of the intact rats and in 100 per cent of the castrates; in castrates injected with testosterone propionate there were tumors in 57.7 per cent of the animals, and in castrates treated with estradiol benzoate, 77.8 per cent. It was concluded that tumor incidence was highest in castrates and lowest in intact males or castrates treated with testosterone propionate, and that estrogen did not affect tumor incidence. Mirand and Staubitz (1956) placed methyleholanthrene crystals in ventral prostates of 99 intact Wistar rats and observed the effects for over 300 days. The resulting tumors were classified as 30 squamous cell carcinomas, 3 leiomyosarcomas, and 2 adenocarcinomas; squamous cell carcinomas and adenocarcinomas metastasized. Fragments of squamous cell carcinomas were transplanted and survived and metastasized more successfully in males than in females.

Horning (1946) impregnated strips of tissue from mouse dorsal prostates and anterior prostates (coagulating glands) with crystals of methyleholanthrene and inserted them as subcutaneous homografts into intact males. By this method adenocarcinomas were induced in grafts of both dorsal prostate and coagulating gland.

In mice of the RIII and Strong A strains (Horning and Dmochowski, 1947) methyleholanthrene in lard was injected into dorsal and anterior prostates (coagulating glands). Squamous cell carcinomas and sarcomas developed in Strong A mice, but only sarcomas in RIII. Squamous metaplasia of

the epithelium occurred in the RIII strain but no malignant proliferation of metaplastic cells followed. It was noted that the epithelial changes which occurred with methyleholanthrene treatment were "almost identical" with the sequence of changes following prolonged estrogen administration in Strong A mice (Horning, 1947).

Horning (1949, 1952) studied the effects of castration, diethylstilbestrol, and testosterone propionate on growth rates of prostatic tumors transplanted as grafts. Tumors were induced in ventral prostate, dorsal prostate, and coagulating gland tissue of Strong A mice by wrapping pieces of epithelium around crystals of methyleholanthrene and transplanting the grafts subcutaneously into 75 intact males. Of the 54 tumors which developed, 42 were adenocarcinomas or secreting glandular carcinomas, 10 were squamous cell carcinomas, and 2 spindle cell sarcomas. Neoplastic development began, apparently, in epithelium in a nonsecretory phase, and hyperplastic changes followed the sequence of mitosis, abnormal cell division, and pyknosis accompanied by an increase in fibromuscular tissue. Three distinct types of epithelial proliferation then occurred; one, with tongue-like groups of early malignant cells, gave rise to secretory glandular carcinomas; the second, from acinar epithelium, and the third, from duct epithelium, developed into squamous cell carcinomas with keratinization and formation of keratin pearls. Some grafts had foci of the first and third type and the evidence suggested that the tumors subsequently became squamous cell carcinomas. Both tumor types were transplantable and were carried through many serial transplantations without losing their histologic characteristics.

In an effort to study effects of testicular androgen on growth, transplants of an adenocarcinoma were made into intact and castrated males. The tumors grew rapidly and progressively in intact mice but regressed in castrates. Testosterone propionate administration to castrated males bearing regressed tumors resulted in a resumption of tumor growth in some cases. Gonadectomy of the host had little effect on the growth of transplanted squamous cell carcinomas. An-

drogen-dependence of secreting glandular carcinomas was suggested.

When stilbestrol pellets were implanted into one flank of intact males and a glandular carcinoma into the opposite flank, the effects varied from slight to pronounced retardation of the tumor but complete regression did not occur. The squamous cell carcinomas were insensitive to stilbestrol.

Additional experiments (Horning, 1952) involved transplanting pieces of prostatic epithelium impregnated with methyleholanthrene alone, or with the carcinogen combined with stilbestrol or testosterone propionate into intact males (groups of 35 for each treatment). The carcinogen alone induced 8 adenocarcinomas and 5 squamous cell carcinomas; carcinogen and stilbestrol, 23 squamous cell carcinomas and 3 sarcomas; carcinogen and testosterone propionate, 2 squamous cell carcinomas and 1 sarcoma. The increased tumor incidence with estradiol was interpreted as an inhibitory action of the estrogen on secretory epithelial cells, making them more susceptible to methyleholanthrene.

Brandes and Bourne (1954) made homografts of pieces of ventral and anterior prostate (coagulating gland) impregnated with methyleholanthrene into intact males of the Strong A strain, and studied histochemical changes. The grafts underwent squamous metaplasia and the processes of epithelial proliferation, stratification, and keratinization were completed within 10 days in some cases. Histochemical changes from the normal pattern (Table 6.8) occurred concurrently. Alkaline phosphatase activity disappeared early; acid phosphatase activity became weak in nuclei and cytoplasm but keratohyalin granules were strongly reactive; PAS-positive reactions were gradually lost in luminal secretion and intracytoplasmic granules but retained in the basement membrane. In some grafts there was transformation into squamous cell carcinomas and when this happened phosphatase activity was lost but the basement membranes were still PAS-positive.

Lasnitzki (1951, 1954, 1955a, b, 1958) grew ventral prostate glands from C3H and Strong A mice in culture by the watch-glass technique and added methyleholanthrene to the medium. Hyperplasia and squamous metaplasia resulted in glands explanted

from both young and older mice. When estrone and carcinogen were added simultaneously to cultures of young glands, squamous metaplasia was increased; with older glands, hyperplasia was inhibited and stromal increase occurred. The relation of vitamin A to the response of prostates to methyleholanthrene was studied (Lasnitzki, 1955b). Vitamin A added to the medium caused an increase in secretion and deposition of PAS-positive material in the secretory cells but did not influence growth or development; the vitamin added simultaneously with methyleholanthrene did not influence hyperplasia, but did prevent keratin formation and degenerative changes in the secretory epithelium; excess vitamin A following the carcinogen prevented formation of keratin and decreased hyperplasia.

**SUMMARY.** Treatment of rat and mouse accessory glands with benzpyrene or methyleholanthrene has induced precancerous and cancerous changes which led to the development of adenocarcinomas, squamous cell carcinomas, and sarcomas. The first type of tumor has been induced in large numbers only in mice and by the homograft method.

The evidence suggests that, in mice, growth of adenocarcinomas is androgen-dependent, but squamous cell carcinomas are little affected by androgen loss or estrogen treatment. The incidence of tumors has been increased by simultaneous administration of estrogen and carcinogen but reduced by the administration of androgen with carcinogen. In rats, it has been affirmed and denied that incidence and growth of squamous cell carcinomas are reduced in intact males; estrogen has not affected tumor incidence. Species and strain differences in response are marked.

#### F. EFFECTS OF NONSTEROID HORMONES

There is evidence that hormones from the anterior pituitary may directly affect the weight and histologic structure of accessory glands, or act synergistically with androgen. However, the findings have been somewhat conflicting. Dosage level, age, and strain of rats have varied, and questions have been raised with respect to the purity of the hormone preparations.

Attention was focused on the pituitary in relation to accessory glands when Huggins and Russell (1946) observed that prostatic

atrophy is more marked in the hypophysectomized than in the castrated dog. Van der Laan (1953) found the ventral prostates of hypophysectomized-castrated immature rats less responsive to testosterone propionate than the glands of castrates; a crude extract of beef pituitaries restored responsiveness in hypophysectomized-castrates. Prostates of young adult hypophysectomized-castrated Sprague-Dawley rats were also less responsive (total weight of dorsal and ventral prostates) to testosterone propionate than those of castrates (Grayhack, Bunce, Kearns and Scott, 1955). Paesi, de Jongh and Hoogstra (1956) administered pituitary extracts simultaneously with a low dose of testosterone propionate to hypophysectomized-castrated rats and reported a slightly greater ventral prostate weight than with the androgen alone.

To identify the hormones of the anterior pituitary that are capable of affecting the accessory glands or influencing their responsiveness to androgen, the following hormone preparations have been injected alone and in various combinations into hypophysectomized-castrated rats: prolactin (luteotrophin; LTH), growth hormone (somatotrophin; STH), adrenocorticotrophin (ACTH), interstitial cell-stimulating hormone (luteinizing hormone; ICSH; LH), follicle stimulating hormone (FSH). In addition, chorionic gonadotrophin and thyroxine have been administered. Of these hormones, only prolactin and growth hormone have been shown to act directly on accessory glands (for comprehensive data on negative and positive results of these hormones see Grayhack, Bunce, Kearns and Scott, 1955; Lostroh and Li, 1956, 1957). The degree to which contamination with prolactin or growth hormone might influence the assay of ICSH preparations by the ventral prostate test has been examined by Lostroh, Squire and Li (1958).

#### 1. Prolactin (LTH)

When Pasqualini (1953) treated castrated adult rats with testosterone propionate followed by administration of a lower dose of androgen plus LTH, the amount of secretion in the seminal vesicles was greater than with androgen alone. Prostate weights were increased slightly by LTH with androgen. Van der Laan (1953) reported that in adult

hypophysectomized-castrated rats LTH had no effect on ventral prostate weight. Grayhack, Bunce, Kearns and Scott (1955) made the same observation for prostate weights in young adult Sprague-Dawley rats, but found that LTH augmented the effect of testosterone propionate on prostate weight.

A difference in response between Long-Evans and Sprague-Dawley strains of rats was observed by Lostroh and Li (1956). In immature hypophysectomized-castrated Long-Evans rats, LTH alone had no effect on ventral prostate or seminal vesicle weights, and no synergistic effect when administered with a low dose of testosterone propionate; in Sprague-Dawleys, however, the weights of ventral prostates and coagulating glands were increased by LTH but, again, no synergism occurred with exogenous androgen. Chase, Geschwind and Bern (1957) reported that in immature hypophysectomized-castrated Sprague-Dawleys, LTH did not affect weights of ventral prostates or coagulating glands but it did increase seminal vesicle weight. When LTH was administered with testosterone propionate, glandular tissue in the ventral prostate was increased and weights of coagulating glands (in some cases) and seminal vesicles were significantly higher than with androgen alone.

In the immature hypophysectomized Sprague-Dawley rats that were not castrated, LTH alone did not affect ventral prostate weight but when given simultaneously with ICSH it acted synergistically (Segaloff, Steelman and Flores, 1956). These results were confirmed by Lostroh, Squire and Li (1958) for the Sprague-Dawley strain, but in Long-Evans rats, LTH neither increased prostatic weight, nor augmented prostatic response to ICSH.

Antliff, Prasad and Meyer (1960) have shown that in the guinea pig, LTH had no effect on seminal vesicles of castrated or hypophysectomized males, but when it was administered with subminimal doses of testosterone propionate, seminal vesicle weight and epithelial height were increased.

## 2. Growth Hormone (STH)

Van der Laan (1953) found no effects of STH on ventral prostate weights in young hypophysectomized-castrated rats. Huggins,

Parsons and Jensen (1955) observed only slight effects on weights of ventral prostates and seminal vesicles with administration of STH to young hypophysectomized-castrated Sprague-Dawley rats, but a synergistic effect on weight was evident with simultaneous treatment with STH and testosterone propionate.

In hypophysectomized-castrated Long-Evans rats (Lostroh and Li, 1956, 1957), STH produced slight histologic changes and significant weight increases in the ventral prostate; when administered with testosterone propionate, an additive effect on weight was obtained. The changes in the seminal vesicles were less evident. The effects on Sprague-Dawley rats included weight increases in ventral prostates and seminal vesicles and a greatly enhanced weight response when STH and testosterone propionate were administered simultaneously (hypophysectomized-castrates in this strain gave a limited response to the androgen). Chase, Geschwind and Bern (1957) found no consistent weight increases of ventral prostates, coagulating glands or seminal vesicles in young hypophysectomized-castrated Sprague-Dawleys treated with STH or STH and testosterone propionate. Simultaneous administration of STH, LTH and testosterone, however, induced significant increases in all accessories above the weights produced by the androgen alone.

Lostroh, Squire and Li (1958) determined that STH had no effect on the ventral prostate response to ICSH in hypophysectomized Long-Evans rats, but produced an enhanced response in Sprague-Dawleys. It was concluded that the Long-Evans strain is preferable for the testing of crude ICSH extracts, inasmuch as neither STH, LTH, nor both simultaneously, affect the response of the ventral prostate to ICSH.

With regard to the action of STH on histologic structure of the prostate in hypophysectomized-castrated rats, it should be noted that the effects are slight; nuclei appear vesicular, and the connective tissue stroma is increased (Lostroh and Li, 1957). The synergistic action of STH on prostate growth in hypophysectomized-castrated rats when administered simultaneously with testosterone is more striking. In a general discussion of the many biologic effects of

growth hormone, Li (1956) wrote, "Does this ability to act as a synergist mean that growth hormone plays a permissive or supporting role in the biological action of a hormone or of a biological agent? It is not unreasonable to assume that growth hormone creates the necessary and sufficient environment for other biological agents to exercise the full scope of their functions."

*Acknowledgments.* We are greatly indebted to Drs. Thaddeus Mann, James Harkin, Helen Deane, Keith Porter, and David Brandes for generously supplying unpublished data and electronmicrographs. Mrs. Eva Brown provided invaluable assistance in the preparation of the manuscript. We wish to thank our artist, Mr. Kenji Toda, for many of the original figures. The researches of one of us (D. P.) cited in the chapter were supported in part by grants from the Dr. Wallace C. and Clara A. Abbott Fund of the University of Chicago and by Research Grants 2912 and 5335 from the National Institutes of Health, Public Health Service.

#### IV. References

- ABUL-FADL, M. A. M., AND KING, E. J. 1948. Properties of the acid phosphatases of erythrocytes and of the human prostate gland. *Biochem. J.*, **45**, 51-60.
- ALEXANDER, D. P., HUGGETT, A. ST. G., NIXON, D. A., AND WIDDAS, W. F. 1955. The placental transfer of sugars in the sheep: the influence of concentration gradient upon the rates of hexose formation as shown in umbilical perfusion of the placenta. *J. Physiol.*, **129**, 367-383.
- ALLEN, J. M. 1953. Responses of the rat prostate gland to methylcholanthrene. *J. Exper. Zool.*, **123**, 289-313.
- ALLEN, J. M. 1956. The influence of hormones on cell division. I. Time-response of ear, seminal vesicle, coagulating gland and ventral prostate of castrate male mice to a single injection of estradiol benzoate. *Exper. Cell Res.*, **10**, 523-532.
- ALLEN, J. M. 1958. The influence of hormones on cell division. II. Time response of ear, seminal vesicle, coagulating gland and ventral prostate of castrate male mice to a single injection of testosterone propionate. *Exper. Cell Res.*, **14**, 142-148.
- ANDREWS, G. S., AND TAYLOR, K. B. 1955. Metabolic studies on surviving prostatic tissue. *Brit. J. Exper. Path.*, **36**, 611-616.
- ANTLIFF, H. A., PRASAD, M. R. N., AND MEYER, R. K. 1960. Action of prolactin on seminal vesicles of guinea pig. *Proc. Soc. Exper. Biol. & Med.*, **103**, 77-80.
- ASPLUND, J. 1947. Quantitative determination of the content of contractive substances in human sperm and their significance for the motility and vitality of spermatozoa. *Acta physiol. scandinav.*, **13**, 103-108.
- ATKINSON, W. B. 1948. Effect of androgen on alkaline phosphatase in the seminal vesicle of the mouse (abst.). *Anat. Rec.*, **100**, 731.
- AWAPARA, J. 1952a. The action of sex hormones on the metabolism of amino acids in the prostate. *Texas Reports Biol. & Med.*, **10**, 22-31.
- AWAPARA, J. 1952b. The influence of sex hormones on the transaminases of the accessory sex organs of the male rat. *Endocrinology*, **51**, 75-79.
- BACON, J. S. D., AND BELL, D. J. 1948. Fructose and glucose in the blood of the foetal sheep. *Biochem. J.*, **42**, 397-405.
- BARON, D. N., GORE, M. B. R., AND WILLIAMS, D. C. 1960. An androgen-activated pyridine nucleotide transhydrogenase in prostatic tissue. *Biochem. J.*, **74**, 20P.
- BARRON, E. S. G., AND HUGGINS, C. 1944. Metabolism of isolated prostatic tissue. *J. Urol.*, **51**, 630-634.
- BARRON, E. S. G., AND HUGGINS, C. 1946a. The citric acid and aconitase content of the prostate. *Proc. Soc. Exper. Biol. & Med.*, **63**, 85-87.
- BARRON, E. S. G., AND HUGGINS, C. 1946b. The metabolism of the prostate: transamination and citric acid. *J. Urol.*, **55**, 385-390.
- BATELLI, F. 1922. Une méthode pour obtenir l'émission complète du liquide des vésicules séminales chez le cobaye. *Compt. rend. Soc. physique et hist. nat. de Genève*, **39**, 73-74.
- BEAUVAILLET, M., AND BROCHART, M. 1949. Présence de nor-adrenaline dans le sperme du Taureau. *Compt. rend. Soc. biol.*, **143**, 237-239.
- BERG, O. C., HUGGINS, C., AND HODGES, C. V. 1941. Concentrations of ascorbic acid and phosphatases in secretions of the male genital tract. *Am. J. Physiol.*, **133**, 82-87.
- BERGSTRÖM, S. 1949. Prostaglandinets kemi. *Nord. Med.*, **42**, 1465-1466.
- BERN, H. A. 1949a. The distribution of alkaline phosphatase in the genital tract of male mammals. *Anat. Rec.*, **104**, 361-377.
- BERN, H. A. 1949b. The effects of sex steroids on the sex accessories in the male Dutch rabbit. *Am. J. Anat.*, **84**, 231-276.
- BERN, H. A. 1951. Estrogen and alkaline phosphatase activity in the genital tract of the male mouse. *Endocrinology*, **48**, 25-33.
- BERN, H. A. 1953. The effect of sex steroids on the respiration of the rat ventral prostate *in vitro*. *J. Endocrinol.*, **9**, 312-321.
- BERN, H. A., AND KRICHESKY, B. 1943. Anatomic and histologic studies of the sex accessories of the male rabbit. *Univ. California Pub. Zool.*, **47**, 175-196.
- BERN, H. A., AND LEVY, R. S. 1952. The effects of castration, estrogen administration, and methylcholanthrene carcinogenesis on phosphatase activities in the genital tract of male rats, guinea pigs, and rabbits. *Am. J. Anat.*, **90**, 131-165.
- BERN, H. A., ALFERT, M. A., AND BLAIR, M. B. 1957. Cytochemical studies of keratin formation and of epithelial metaplasia in the rodent vagina and prostate. *J. Histochem. & Cytochem.*, **5**, 105-119.
- BERNARD, C. 1855. *Leçons de physiologie comparée*

- menh.*, Vol. I, p. 405. Paris: J. B. Baillièrè et fils.
- BERTHOLD, A. A. 1849. Transplantation der Hoden. *Arch. Anat., Physiol. u. wissenschaft. Med.*, **42**-46.
- BERTRAND, G., AND VLADESCO, M. R. 1921. Intervention probable du zinc dans les phénomènes de fécondation chez les animaux vertébrés. *Compt. rend. Acad. Sc.*, **173**, 176-179.
- BLANDAU, R. J. 1945. On the factors involved in sperm transport through the cervix uteri of the albino rat. *Am. J. Anat.*, **77**, 253-272.
- BOCARIUS, N. 1902. Zur Kenntnis der Substanz, welche die Bildung von Florenc'schen Krystallen bedingt. *Ztschr. Physiol. Chem.*, **34**, 339-346.
- BOGUTH, W. 1952. Über den Plasmalogengehalt im Sperma. *Naturwiss.*, **39**, 432-433.
- BOMAN, H. G. 1954. Adsorption of prostatic phosphatase on ion-exchange resin. *Nature, London*, **173**, 447-448.
- BRAMBELL, F. W. R., AND DAVIS, D. H. S. 1940. The normal occurrence, structure and homology of prostatic glands in adult female *Mastomys erythroleucus* Temm. *J. Anat.*, **75**, 64-74.
- BRANDES, D., AND BOURNE, G. H. 1954. The histochemistry of the prostate in normal and in castrated and hormone-treated mice and of prostatic homografts exposed to 20-methylcholanthrene. *Brit. J. Exper. Path.*, **35**, 577-588.
- BRANDES, D., AND GROTH, D. P. 1961. The fine structure of the rat prostatic complex. *Exper. Cell Res.*, **23**, 159-175.
- BRANDES, D., AND PORTELA, A. 1960a. The fine structure of the epithelial cells of the rat prostate (abst.). *Anat. Rec.*, **136**, 332.
- BRANDES, D., AND PORTELA, A. 1960b. The fine structure of the epithelial cells of the mouse prostate. I. Coagulating gland epithelium. *J. Biophys. & Biochem. Cytol.*, **7**, 505-510.
- BRANDES, D., AND PORTELA, A. 1960c. The fine structure of the epithelial cells of the mouse prostate. II. Ventral lobe epithelium. *J. Biophys. & Biochem. Cytol.*, **7**, 511-514.
- BRANDES, D., BELT, W. D., AND BOURNE, G. H. 1959. Preliminary remarks concerning the fine structure of the epithelium of the coagulating gland. *Exper. Cell Res.*, **16**, 683-685.
- BRANTON, C., D'ARENSBORG, G., AND JOHNSTON, J. E. 1952. Sperm production, fructose content of semen and fertility of dairy bulls as related to sexual excitement. *J. Dairy Sc.*, **35**, 801-807.
- BRENDLER, H. 1919. Effect of a folic acid antagonist on hormonally induced changes in the rat prostate. *Science*, **110**, 119-120.
- BRENDLER, H. 1956. Endocrine regulation of prostatic growth. In *Hormones and the Aging Process*, G. Pincus, Ed., pp. 273-282. New York: Academic Press, Inc.
- BRENDLER, H., CHASE, W. E., AND SCOTT, W. W. 1950. Prostatic cancer. Further investigation of hormonal relationships. *Arch. Surg.*, **61**, 433-440.
- BROCHART, D. 1948. Présence de l'adrenaline dans le sperme des Mammifères. *Compt. rend. Soc. biol.*, **142**, 646-647.
- BRUNER, J. A., AND WITSCHI, E. 1946. Testosterone-induced modifications of sex development in female hamsters. *Am. J. Anat.*, **79**, 293-320.
- BURKHART, E. Z. 1942. A study of the early effects of androgenic substances in the rat by the aid of colchicine. *J. Exper. Zool.*, **89**, 135-165.
- BURRILL, M. W., AND GREENE, R. R. 1939a. Androgenic function of the adrenals in the immature male castrate rat. *Proc. Soc. Exper. Biol. & Med.*, **40**, 327-330.
- BURRILL, M. W., AND GREENE, R. R. 1939b. Androgen production in normal, intact and castrate immature rats. *Proc. Soc. Exper. Biol. & Med.*, **42**, 764-766.
- BURRILL, M. W., AND GREENE, R. R. 1941. Androgen production in the female rat. The ovary and the adrenal in the immature rat. *Endocrinology*, **28**, 871-873.
- BURRILL, M. W., AND GREENE, R. R. 1942. Androgen production during pregnancy and lactation in the rat. *Anat. Rec.*, **83**, 209-227.
- BURROWS, H. 1935a. Pathological conditions induced by oestrogenic compounds in the coagulating glands and prostate of the mouse. *Am. J. Cancer*, **23**, 490-512.
- BURROWS, H. 1935b. The localization of response to oestrogenic compounds in the organs of male mice. *J. Path. & Bact.*, **41**, 423-429.
- BURROWS, H. 1949. *Biological Actions of Sex Hormones*, 2nd ed. Cambridge: Cambridge University Press.
- BURROWS, H., AND KENWAY, N. M. 1934. On some effects produced by applying oestrin to the skin of mice. *Am. J. Cancer*, **20**, 48-57.
- BUTLER, W. W. S., III, AND SCHADE, A. L. 1958. The effects of castration and androgen replacement on the nucleic acid composition, metabolism, and enzymatic capacities of the rat ventral prostate. *Endocrinology*, **63**, 271-279.
- CABOT, A. T. 1896. The question of castration for enlarged prostate. *Ann. Surg.*, **24**, 265-309.
- CALLOW, R. C., AND DEANESLY, R. 1935. Effect of androsterone and of male hormone concentrates on the accessory reproductive organs of castrated rats, mice and guinea-pigs. *Biochem. J.*, **29**, 1424-1445.
- CAMUS, L., AND GLEY, E. 1896. Action coagulante du liquide prostatique sur le contenu des vésicules séminales. *Compt. rend. Soc. biol.*, **48**, 787-788.
- CAMUS, L., AND GLEY, E. 1899. Action coagulante de liquide de la prostate externe du Hérisson sur le contenu des vésicules séminales. *Compt. rend. Acad. Sc.*, **128**, 1417-1419.
- CAVAZOS, L. F., AND MELAMPY, R. M. 1951. Cytological effects of testosterone propionate on epithelium of rat seminal vesicles. *Endocrinology*, **54**, 640-648.
- CHASE, E. B. 1939. The reproductive system of the male opossum, *Didelphis virginiana* Kerr and its experimental modification. *J. Morphol.*, **65**, 245-239.



- CHASE, M. D., GESCHWIND, I. I., AND BERN, H. A. 1957. Synergistic role of prolactin in response of male rat sex accessories to androgen. *Proc. Soc. Exper. Biol. & Med.*, **94**, 680-683.
- CIERNICK, S. S., CHAIKOFF, I. L., AND ABRAHAM, S. 1951. Localization of initial block in glucose metabolism in diabetic liver slices. *J. Biol. Chem.*, **193**, 793-802.
- CLEGG, E. J. 1953. The arterial supply of the seminal vesicles and coagulating gland in the rat, and the effects of its interruption. *Proc. Soc. Study Fertil.*, **5**, 71-81.
- COCKRILL, J. R., MILLER, E. G., AND KURZROK, R. 1935. The substance in human seminal fluid affecting uterine muscle. *Am. J. Physiol.*, **112**, 577-580.
- CONCHE, J., AND FINDLAY, J. 1959. Influence of gonadectomy, sex hormones and other factors, on the activity of certain glycosidases in the rat and mouse. *J. Endocrinol.*, **18**, 132-146.
- CONCHE, J., AND MANN, T. 1957. Glycosidases in mammalian sperm and seminal plasma. *Nature, London*, **179**, 1190-1191.
- CONCHE, J., FINDLAY, J., AND LEVY, G. A. 1956.  $\alpha$ -Mannosidase and other glycosidases in the tissues of the mouse and the rat, with special reference to the sex organs. *Nature, London*, **178**, 1469.
- COURRIER, R. 1924. Le cycle sexuel chez les femelles des Mammifères. Etude de la phase folliculaire. *Arch. Biol. Paris*, **34**, 369-477.
- COURRIER, R., BACLESE, M., AND MAROIS, M. 1953. Rapports de la corticosurrénale et de la sexualité. *J. Physiol.*, **45**, 327-374.
- DAVEY, P. L. H., AND FOSTER, C. L. 1950. Basophilia in the rodent prostate. *Nature, London*, **165**, 607-608.
- DAVID, K., FREUD, J., AND DE JONGH, S. E. 1934. Conditions of hypertrophy of seminal vesicles in rats. II. The effect of derivatives of oestrone (menformon). *Biochem. J.*, **28**, 1360-1367.
- DAVIDSON, C. S., AND MOON, H. D. 1936. Effects of adrenocorticotrophic extracts on accessory reproductive organs of castrate rats. *Proc. Soc. Exper. Biol. & Med.*, **35**, 281-282.
- DAVIES, D. V., AND MANN, T. 1947. Functional development of accessory glands and spermiogenesis. *Nature, London*, **160**, 295.
- DAVIES, D. V., AND MANN, T. 1949. The function, anatomy and "development" of the prostate gland in the rabbit. *J. Anat.*, **81**, 385-386.
- DAVIES, D. V., MANN, T., AND ROWSON, L. E. A. 1957. Effect of nutrition on the onset of male sex hormone activity and sperm formation in monozygous bull-calves. *Proc. Roy. Soc. London, ser. B*, **147**, 332-351.
- DAVIS, J. S., MEYER, R. K., AND McSHAN, W. H. 1949. Effect of androgen and estrogen on succinic dehydrogenase and cytochrome oxidase of rat prostate and seminal vesicle. *Endocrinology*, **44**, 1-7.
- DAWSON, R. M. C., MANN, T., AND WHITE, I. G. 1957. Glycerophosphorylcholine and phosphorylcholine in semen, and their relation to choline. *Biochem. J.*, **65**, 627-634.
- DEANE, H. W., AND DEMPSEY, E. W. 1945. The localization of phosphatases in the Golgi region of intestinal and other epithelial cells. *Anat. Rec.*, **93**, 401-417.
- DEANE, H. W., AND PORTER, K. R. 1959. Correlated histochemical and electron microscopic observations on the mouse seminal vesicle. *J. Histochem. & Cytochem.*, **7**, 315-316.
- DEANESLY, R. 1934. The reproductive processes of certain mammals. VI. The reproductive cycle of the female hedgehog. *Philos. Trans. Soc. London, ser. B*, **223**, 239-276.
- DEANESLY, R. 1938. Androgenic activity of ovarian grafts in castrated male rats. *Proc. Roy. Soc. London, ser. B*, **126**, 122-135.
- DEANESLY, R. 1960. A test of androgen production by the rat adrenal. *J. Endocrinol.*, **20**, vii-viii.
- DEANESLY, R., AND PARKES, A. S. 1933. Size changes in the seminal vesicles of the mouse during development and after castration. *J. Physiol.*, **78**, 442-450.
- DE JONGH, S. E. 1935. Paradoxe Wirkungen von Follikelhormon (Menformon) bei männlichen Tieren; ihre Beeinflussbarkeit durch männliches Hormon. *Arch. internat. pharmacodyn.*, **50**, 348-378.
- DE JONGH, S. E., AND KORTIEWEG, R. 1935. Der Einfluss von Ovarimplantationen auf die kastrierte männliche Maus. *Acta brev. neerl. physiol.*, **5**, 126-127.
- DELOST, P. 1953a. Existence de glandes prostatiques chez le campagnol des champs (*Microtus arvalis* P.) de sexe femelle. *Compt. rend. Soc. biol.*, **147**, 758-760.
- DELOST, P. 1953b. Sur le développement des glandes prostatiques chez le campagnol des champs (*Microtus arvalis* P.) de sexe femelle. Rôle du cortex surrénal. *Compt. rend. Soc. biol.*, **147**, 760-762.
- DELOST, P. 1956. Les cotéclations gémito-surrénales chez le campagnol des champs (*Microtus arvalis* P.). *Ann. Sc. nat. Zool.*, **18**, 391-567.
- DEMPSEY, E. W., GREEP, R. O., AND DEANE, H. D. 1949. Changes in the distribution and concentration of alkaline phosphatases in tissues of the rat after hypophysectomy or gonadectomy and after replacement therapy. *Endocrinology*, **44**, 88-103.
- DIAMENT, M. 1954. *La choline hydrosoluble combinée des tissus*, pp. 1-99. Thesis, University of Paris.
- DIAMENT, M., KAHANE, E., AND LEVY, J. 1952. Sur les esters hydrosolubles de la choline. La glycérilphosphorylcholine. *Compt. rend. Acad. Sc.*, **235**, 1058-1060.
- DIAMENT, M., KAHANE, E., AND LEVY, J. 1953. La "choline hydrosoluble" combinée. S'identifie-t-elle à la glycérilphosphorylcholine? *Arch. zool. Physiol.*, **7**, 45-62.
- DICZFALUSY, E. 1954. Characterization of the

- trogens in human semen. *Acta Endocrinol.*, **15**, 317-321.
- DIRSCHIEL, W., AND KNÜCHEL, W. 1950. Über das Vorkommen von Androgenen im menschlichen und tierischen Sperma. *Biochem. Ztschr.*, **320**, 253-257.
- DIRSCHIEL, W., BREITER, H., AND SCHELLER, S. 1955. Über die Wirkung von Steroidhormonen auf den Gewebstoffwechsel der Vesiculardrüsen von Maus und Ratte. *Biochem. Ztschr.*, **326**, 204-208.
- DIXON, F. J., AND MOORE, R. A. 1952. *Tumors of the Male Sex Organs*. Washington: Armed Forces Institute of Pathology.
- DORFMAN, R. I. 1950. Physiology of androgens. In *The Hormones*, G. Pincus and K. V. Thimimi, Eds., Vol. 2, pp. 33-61. New York: Academic Press, Inc.
- DORFMAN, R. I. 1957. Biochemistry of the steroid hormones. *Ann. Rev. Biochem.*, **26**, 523-560.
- DORFMAN, R. I., AND SHIPLEY, R. A. 1956. *Androgens: Biochemistry, Physiology, and Clinical Significance*. New York: J. Wiley and Sons.
- DUDLEY, H. W., ROSENHEIM, O., AND STARLING, W. W. 1926. The chemical constitution of spermine. III. Structure and synthesis. *Biochem. J.*, **20**, 1082-1093.
- DUDLEY, H. W., ROSENHEIM, O., AND STARLING, W. W. 1927. The constitution and synthesis of spermidine, a newly discovered base isolated from animal tissues. *Biochem. J.*, **21**, 97-103.
- DUNNING, W. F., CURTIS, M. R., AND SEGALOFF, A. 1946. Methylcholanthrene squamous cell carcinoma of the rat prostate with skeletal metastases, and failure of the rat liver to respond to the same carcinogen. *Cancer Res.*, **6**, 256-262.
- EADIE, W. R. 1947. Homologies of the male accessory reproductive glands in *Sorex* and *Blarina*. *Anat. Rec.*, **98**, 347-359.
- EADIE, W. R. 1948a. The male accessory reproductive glands of *Condylura* with notes on a unique prostatic secretion. *Anat. Rec.*, **101**, 59-79.
- EADIE, W. R. 1948b. Corpora amylacea in the prostatic secretion and experiments on the formation of a copulatory plug in some insectivores. *Anat. Rec.*, **102**, 259-271.
- ECKHARD, C. 1863. Untersuchungen über die Erektion des Penis beim Hunde. *Eckhard's Beitr. Anat. Physiol.*, **3**, 123-166.
- ECKSTEIN, P., AND ZUCKERMAN, S. 1956. Morphology of the reproductive tract. In *Marshall's Physiology of Reproduction*, A. S. Parkes, Ed., Vol. 1, Part 1, pp. 43-155. London: Longmans Green & Company.
- ELIASSON, R. 1957. A comparative study of prostaglandin from human seminal fluid and from prostatic gland of sheep. *Acta physiol. scandinav.*, **39**, 141-146.
- ELSCHLEPP, J. G. 1952. The urogenital organs of the cottontail rabbit (*Sylvilagus floridanus*). *J. Morphol.*, **91**, 169-198.
- EMMENS, C. W., AND PARKES, A. S. 1947. Effect of exogenous oestrogens on the male mammal. *Vitamins & Hormones*, **5**, 233-272.
- ENGLE, E. T. 1926a. The copulation plug and the accessory genital glands of mammals. *J. Mammol.*, **7**, 119-126.
- ENGLE, E. T. 1926b. A morphological and experimental study of the proximal lobes of the prostate of the guinea-pig, *Cavia cobaya*. *Anat. Rec.*, **34**, 75-90.
- FARRELL, J. I. 1931. Studies on the secretion of the prostate gland. I. A method for collecting the pure secretion in the dog. II. Factors influencing the secretion of prostatic fluid. III. Some properties of the prostatic secretion of the dog. *Tr. Am. A. Genito-Urin. Surgeons*, **24**, 221-230.
- FARRELL, J. I. 1938. The newer physiology of the prostate gland. *J. Urol.*, **39**, 171-185.
- FARRELL, J. I., AND LYMAN, Y. 1937. A study of the secretory nerves of, and the action of certain drugs on, the prostate gland. *Am. J. Physiol.*, **118**, 64-70.
- FARNSWORTHY, W. E. 1958. Influence of androgens on rat ventral prostate oxidative and synthetic processes *in vitro*. *Fed. Proc.*, **17**, 217.
- FERGUSON, J. D. 1958. Endocrine-control therapy in prostatic cancer. *Brit. J. Urol.*, **18**, 397-406.
- FISCHER, M. I., TIKKALA, A. O., AND MAWSON, C. A. 1955. Zinc, carbonic anhydrase and phosphatase in the prostate glands of the rat. *Canad. J. Biochem. & Physiol.*, **33**, 181-190.
- FISHMAN, W. H., AND LERNER, F. A. 1953. Method for estimating serum acid phosphatase of prostatic origin. *J. Biol. Chem.*, **200**, 89-97.
- FLEISCHHAUER, K. 1957. Makroskopischer und mikroskopischer Nachweis von Differenzen im Schwermetallgehalt einzelner Lappen der Rattenprostata. *Naturwiss.*, **44**, 589.
- FLEISCHMANN, W., AND FLEISCHMANN, S. K. 1952. Uptake of  $P^{32}$  in seminal vesicles of castrate rats after treatment with testosterone propionate. *J. Mt. Sinai Hosp.*, **19**, 228-232.
- FLETSCHER, J. P., BEST, C. H., AND SOLANDT, O. M. 1935. The distribution of choline. *Biochem. J.*, **29**, 2278-2284.
- FLORENCE, A. 1895. Du sperme et des taches de sperme en médecine légale. *Arch. anthrop. crim., psychiat. e. méd. légale*, **10**, 417-431.
- FRANKS, L. M. 1951. Benign nodular hyperplasia of the prostate: a review. *Ann. Roy. Coll. Surg.*, **14**, 92-106.
- FRANKS, L. M. 1958. Some comments on the long-term results of endocrine treatment of prostatic cancer. *Brit. J. Urol.*, **18**, 383-391.
- FRANKS, L. M. 1959. The effects of age on the structure and response to oestrogens and testosterone, of the mouse prostate in organ cultures. *Brit. J. Cancer*, **13**, 59-68.
- FREUD, J. 1933. Conditions of hypertrophy of the seminal vesicles in rats. *Biochem. J.*, **27**, 1138-1150.
- FREUD, J., AND THOMPSON, G. E. 1957. Toxic effects of fluid from the coagulating gland of the guinea pig. *Proc. Soc. Exper. Biol. & Med.*, **94**, 350-351.
- FREUND, J., MILES, A. A., MILL, P. J., AND WILHELM,

- D. L. 1958. Vascular permeability factors in the secretion of the guinea pig coagulating gland. *Nature, London*, **182**, 174-175.
- FUEBERLINGER, P. 1881. Untersuchungen über die Herkunft und klinische Bedeutung der sogenannten Spermakristalle nebst Bemerkungen über die Komponenten des menschlichen Samens und die Prostatorrhöe. *Ztschr. Klin. Med.*, **3**, 287-316.
- FUJITA, M. 1959. The fine structure of the epithelial cell of the mouse seminal vesicle studied with electron microscope (in Japanese with an English summary). *J. Kurume M. A.*, **22**, 536-558.
- GASSNER, F. X., AND HOPWOOD, M. L. 1952. Seminal amino acid and carbohydrate pattern of bulls with normal and abnormal testis function. *Proc. Soc. Exper. Biol. & Med.*, **81**, 37-43.
- GASSNER, F. X., HILL, H. J., AND SULZBERGER, L. 1952. Relationship of seminal fructose to testis function in the domestic animal. *Fertil. & Steril.*, **3**, 121-140.
- GERSH, I., AND GROLLMAN, A. 1939. The relation of the adrenal cortex to the male reproductive system. *Am. J. Physiol.*, **126**, 368-371.
- GLOCK, G. E., AND MCLEAN, P. 1955. Levels of oxidized and reduced diphosphopyridine nucleotide and triphosphopyridine nucleotide in animal tissues. *Biochem. J.*, **61**, 388-390.
- GLOVER, T. 1956. The effect of serotal insulation and the influence of the breeding season upon fructose concentration in the semen of the ram. *J. Endocrinol.*, **13**, 235-242.
- GODET, R. 1949. Recherches d'anatomie, d'embryologie normale et expérimentale sur l'appareil génital de la taupe (*Talpa europaea* L.). *Bull. Biol. France et Belgique*, **83**, 25-111.
- GOLDBLATT, M. W. 1935. Constituents of human seminal plasma. *Biochem. J.*, **29**, 1346-1357.
- GOLDSMITH, E. D., AND NIGRELLI, R. F. 1950. The response of the male mouse sex accessories to testosterone during maturation. *Tr. New York Acad. Sc.*, **12**, 236-237.
- GOTTERER, G. S., AND WILLIAMS-ASHMAN, H. G. 1957. Some factors which influence vesiculase action. *Proc. Soc. Exper. Biol. & Med.*, **94**, 60-64.
- GOTTERER, G., BANKS, J., AND WILLIAMS-ASHMAN, H. G. 1956. Hydrolysis of arginine esters by male accessory sexual tissues. *Proc. Soc. Exper. Biol. & Med.*, **92**, 58-61.
- GOTTERER, G., GINSBURG, D., SCHULMAN, T., BANKS, J., AND WILLIAMS-ASHMAN, H. G. 1955. Enzymatic coagulation of semen. *Nature, London*, **176**, 1209-1211.
- GRAY, S., AND HUGGINS, C. 1942. Electrophoretic analysis of human semen. *Proc. Soc. Exper. Biol. & Med.*, **50**, 351-353.
- GRAYHACK, J. T., AND SCOTT, W. W. 1952. The effect of general dietary deficiencies on the response of the prostate of the albino rat to testosterone propionate. *Endocrinology*, **50**, 406-411.
- GRAYHACK, J. T., BUNCE, P. L., KEARNS, J. W., AND SCOTT, W. W. 1955. Influence of the pituitary on prostatic response to androgen in the rat. *Bull. Johns Hopkins Hosp.*, **96**, 154-163.
- GREENE, R. R., AND BURRILL, M. W. 1939. Androgen production in normal intact and castrate immature female rats. *Proc. Soc. Exper. Biol. & Med.*, **42**, 764-766.
- GREENE, R. R., BURRILL, M. W., AND THOMSON, D. M. 1940. Further studies on the androgenicity of progesterone. *Endocrinology*, **27**, 469-472.
- GUNN, S. A., AND GOULD, T. C. 1956a. Differences between dorsal and lateral components of the dorsolateral prostate of rat in  $Zn^{65}$  uptake. *Proc. Soc. Exper. Biol. & Med.*, **92**, 17-20.
- GUNN, S. A., AND GOULD, T. C. 1956b. The relative importance of androgen and estrogen in the selective uptake of  $Zn^{65}$  by the dorsolateral prostate of the rat. *Endocrinology*, **58**, 443-452.
- GUNN, S. A., AND GOULD, T. C. 1957a. A correlative anatomical and functional study of the dorsolateral prostate of the rat. *Anat. Rec.*, **128**, 41-53.
- GUNN, S. A., AND GOULD, T. C. 1957b. Hormonal interrelationships affecting the selective uptake of  $Zn^{65}$  by the dorsolateral prostate of the hypophysectomized rat. *J. Endocrinol.*, **16**, 18-27.
- GUNN, S. A., AND GOULD, T. C. 1958. Role of zinc in fertility and fecundity in the rat. *Am. J. Physiol.*, **193**, 505-508.
- GUNN, S. A., GOULD, T. C., GINORI, S. S., AND MORSE, J. G. 1955. Selective uptake of  $Zn^{65}$  by dorsolateral prostate of rat. *Proc. Soc. Exper. Biol. & Med.*, **88**, 556-558.
- GUTMAN, A. B., AND GUTMAN, E. B. 1938a. "Acid" phosphatase and functional activity of the prostate (man) and preputial glands (rat). *Proc. Soc. Exper. Biol. & Med.*, **39**, 529-532.
- GUTMAN, A. B., AND GUTMAN, E. B. 1938b. An "acid" phosphatase occurring in the serum of patients with metastasizing carcinoma of the prostate gland. *J. Clin. Invest.*, **17**, 473-478.
- GUTMAN, E. B., AND GUTMAN, A. B. 1940. Estimation of acid phosphatase activity of blood serum. *J. Biol. Chem.*, **136**, 201-209.
- GUTMAN, E. B., SPROUL, E. E., AND GUTMAN, A. B. 1936. Significance of increased phosphatase activity at the site of osteoplastic metastases secondary to carcinoma of the prostate. *Am. J. Cancer*, **28**, 485-495.
- HAGERMAN, D. D., AND VILLEE, C. A. 1959. Separation of human placental estrogen-sensitive transhydrogenase from estradiol-17 $\beta$  dehydrogenase. *J. Biol. Chem.*, **234**, 2031-2036.
- HAMMEN, R. 1944. *Studies on Impaired Fertility in Man, with Special Reference to the Male*. Copenhagen: Ejnar Munksgaards Forlag.
- HARKIN, J. C. 1957a. An electron microscopic study of the castration changes in the rat prostate. *Endocrinology*, **60**, 185-199.
- HARKIN, J. C. 1957b. Electron microscopic study of the age changes in the rat prostate and comparison with prostatic hyperplasia in the rat. *Am. J. Path.*, **33**, 602.

- HARRISON, G. A. 1931. Spermine in human tissues. *Biochem. J.*, **25**, 1885-1892.
- HAMSH, R., OVERHOLSER, M. D. AND WELLS, L. J. 1939. Effects of oestrogen and androgen injections on reproductive organs in male rats and mice. *J. Endocrinol.*, **1**, 261-267.
- HARTMAN, C. G. 1924. Observations on the motility of the opossum genital tract and the vaginal plug. *Anat. Rec.*, **27**, 293-304.
- HARTREE, E. F. 1957. Inositol in seminal plasma. *Biochem. J.*, **66**, 131-137.
- HARTREE, E. F., AND MANN, T. 1959. Plasmalogen in ram semen, and its role in sperm metabolism. *Biochem. J.*, **71**, 423-433.
- HARVEY, C. 1948. Relation between the volume and fructose content of human semen. *Nature*, London, **162**, 812-813.
- HARVEY, C. 1949. Fibrinolysin in human semen. A method of assay and some preliminary observations. *Proc. Soc. Study Fertil.*, **1**, 11-17.
- HEATH, H., RIMINGTON, C., AND MANN, T. 1957. Further studies on seminal ergothioneine of the pig. *Biochem. J.*, **65**, 369-373.
- HEATH, H., RIMINGTON, C., GLOVER, T., MANN, T., AND LEONE, E. 1953. Studies using radioactive sulphur on ergothioneine formation in the pig. *Biochem. J.*, **54**, 606-611.
- HEPPEL, L. A., AND HILMOE, R. J. 1951a. Purification and properties of 5'-nucleotidase. *J. Biol. Chem.*, **188**, 665-676.
- HEPPEL, L. A., AND HILMOE, R. J. 1951b. Purification of yeast inorganic pyrophosphatase. *J. Biol. Chem.*, **192**, 87-94.
- HEPPEL, L. A., AND HILMOE, R. J. 1953. Mechanism of enzymatic hydrolysis of adenosine triphosphate. *J. Biol. Chem.*, **202**, 217-226.
- HERNANDEZ, T. 1942. Hormonal ambisexuality of ovarian grafts in female rats. *Am. J. Anat.*, **73**, 127-151.
- HERS, H. G. 1956. Le mécanisme de la transformation de glucose en fructose par les vésicules séminales. *Biochim. Biophys. Acta*, **22**, 203-204.
- HERS, H. G. 1957a. *La métabolisme du fructose*. Bruxelles: Editions Arscia.
- HERS, H. G. 1957b. Presence of sorbitol in seminal vesicles and in foetal blood of the sheep. *Biochem. J.*, **66**, 30P.
- HERTZ, R. 1951. The relationship between hormone-induced tissue growth and neoplasia. A review. *Cancer Res.*, **11**, 393-397.
- HILL, R. T. 1937. Ovaries secrete male hormone. *Endocrinology*, **21**, 495-502.
- HOMMA, K. 1952. Metabolism of the prostate. *Med. & Biol.*, **23**, 133-135.
- HORNING, E. S. 1946. Induction of glandular carcinomas of the prostate in the mouse. *Lancet*, **251**, 829-830.
- HORNING, E. S. 1947. The action of diethylstilboestrol on the prostatic epithelium of the mouse. *Quart. J. Microscop. Sc.*, **88**, 45-53.
- HORNING, E. S. 1949. The effects of castration and stilboestrol on prostatic tumours in mice. *Brit. J. Cancer*, **3**, 211-230.
- HORNING, E. S. 1952. Steroid hormones and prostatic cancer in mice. *Ciba Foundation Colloquia Endocrinol.*, **1**, 31-45.
- HORNING, E. S., AND DMOCHOWSKI, L. 1947. Induction of prostatic tumours in mice. *Brit. J. Cancer*, **1**, 59-63.
- HOWARD, E. 1938. The representation of the adrenal X zone in rats, in the light of observations on X zone variability in mice. *Am. J. Anat.*, **62**, 351-373.
- HOWARD, E. 1939. Effects of castration on the seminal vesicles as influenced by age, considered in relation to the degree of development of the adrenal X zone. *Am. J. Anat.*, **65**, 105-149.
- HOWARD, E. 1941. Effects of adrenalectomy and desoxycorticosterone substitution therapy on the castrated rat prostate. *Endocrinology*, **29**, 746-754.
- HOWARD, E. 1946. The effect of adrenalectomy on the accessory reproductive glands of mice castrated for short periods. *Endocrinology*, **38**, 156-164.
- HUGGINS, C. 1942. Effect of orchietomy and irradiation on cancer of the prostate. *Ann. Surg.*, **115**, 1192-1200.
- HUGGINS, C. 1943. Endocrine control of prostatic cancer. *Science*, **97**, 541-544.
- HUGGINS, C. 1945. The physiology of the prostate gland. *Physiol. Rev.*, **25**, 281-295.
- HUGGINS, C. 1947a. Anti-androgenic treatment of prostatic carcinoma in man. In *Approaches to Tumor Chemotherapy*, pp. 379-383. Washington, D. C.: American Association for the Advancement of Science.
- HUGGINS, C. 1947b. The etiology of benign prostatic hypertrophy. *Bull. New York Acad. Med.*, **23**, 696-704.
- HUGGINS, C. 1947c. The prostatic secretion. *Harvey Lectures*, **42**, 148-193.
- HUGGINS, C. 1956. Control of cancers of man by endocrinologic methods. A review. *Cancer Res.*, **16**, 825-830.
- HUGGINS, C., AND BERGENSTAL, D. M. 1951. Surgery of the adrenals. *J. A. M. A.*, **147**, 101-106.
- HUGGINS, C., AND BERGENSTAL, D. M. 1952. Inhibition of human mammary and prostatic cancers by adrenalectomy. *Cancer Res.*, **12**, 134-141.
- HUGGINS, C., AND CLARK, P. J. 1940. Quantitative studies of prostatic secretion. II. The effect of castration and of estrogen injection on the normal and on the hyperplastic prostatic glands of dogs. *J. Exper. Med.*, **72**, 747-762.
- HUGGINS, C., AND HODGES, C. V. 1941. Studies on prostatic cancer. I. The effect of castration, of estrogen and of androgen injection on serum phosphatases in metastatic carcinoma of the prostate. *Cancer Res.*, **1**, 293-297.
- HUGGINS, C., AND JENSEN, E. V. 1951. Significance of the hydroxyl groups of steroids in promoting growth. *J. Exper. Med.*, **100**, 241-246.
- HUGGINS, C., AND JOHNSON, A. 1933. Chemical observations on fluids of seminal tract. I. Inorganic phosphorus, calcium, non-protein nitrogen and glucose content of semen and seminal

- vesicle, prostate and spermatozoole fluids in man. *Am. J. Physiol.*, **103**, 574-581.
- HUGGINS, C., AND MOULDER, P. V. 1945. Estrogen production by Sertoli cell tumors of the testis. *Cancer Res.*, **5**, 510-514.
- HUGGINS, C., AND MOULTON, S. H. 1948. Esterases of testis and other tissues. *J. Exper. Med.*, **88**, 169-179.
- HUGGINS, C., AND NEAL, W. J. 1942. Coagulation and liquefaction of semen. Proteolytic enzymes and citrate in prostatic fluid. *J. Exper. Med.*, **76**, 527-541.
- HUGGINS, C., AND RUSSELL, P. S. 1946. Quantitative effects of hypophysectomy on testis and prostate of dogs. *Endocrinology*, **39**, 1-7.
- HUGGINS, C., AND SCOTT, W. W. 1945. Bilateral adrenalectomy in prostatic cancer. Clinical features and urinary excretion of 17-ketosteroids and estrogen. *Ann. Surg.*, **122**, 1031-1041.
- HUGGINS, C., AND SMITH, D. R. 1947. Chromogenic substrates. III. *p*-Nitrophenyl sulfate as a substrate for the assay of phenol-sulfatase activity. *J. Biol. Chem.*, **170**, 391-398.
- HUGGINS, C., AND SOMMER, J. L. 1953. Quantitative studies of prostatic secretion. III. Simultaneous measurement of size and secretion of the canine prostate and the interaction of androgenic and estrogenic substances thereon. *J. Exper. Med.*, **97**, 663-680.
- HUGGINS, C., AND STEVENS, R. S. 1940. The effect of castration on benign hypertrophy of the prostate in man. *J. Urol.*, **43**, 705-713.
- HUGGINS, C., AND WEBSTER, W. O. 1948. Duality of human prostate in response to estrogen. *J. Urol.*, **59**, 258-266.
- HUGGINS, C., PARSONS, F. M., AND JENSEN, E. V. 1955. Promotion of growth of preputial glands by steroids and the pituitary growth hormone. *Endocrinology*, **57**, 25-32.
- HUGGINS, C., SCOTT, W. W., AND HEINEN, J. H. 1942. Chemical composition of human semen and the secretions of the prostate and seminal vesicles. *Am. J. Physiol.*, **136**, 467-473.
- HUGGINS, C., SCOTT, W. W., AND HODGES, C. V. 1941. Studies on prostatic cancer. III. The effects of fever, of desoxycorticosterone and of estrogen on clinical patients with metastatic carcinoma of the prostate. *J. Urol.*, **46**, 997-1006.
- HUGGINS, C., STEVENS, R. E., JR., AND HODGES, C. V. 1941. Studies on prostatic cancer. II. The effects of castration on advanced carcinoma of the prostate gland. *Arch. Surg.*, **43**, 209-223.
- HUGGINS, C., MASINA, M. H., EICHELBERGER, L., AND WHARTON, J. D. 1939. Quantitative studies of prostatic secretion. I. Characteristics of the normal secretion; the influence of thyroid, suprarenal and testis extirpation and androgen substitution on the prostatic output. *J. Exper. Med.*, **70**, 543-556.
- HUMPHREY, G. F. 1957. The distribution and properties of transhydrogenase from animal tissues. *Biochem. J.*, **65**, 516-550.
- HUMPHREY, G. F., AND MANN, T. 1949. Studies on the metabolism of semen. 5. Citric acid in semen. *Biochem. J.*, **44**, 97-105.
- HUNTER, J. 1792. Observations on the glands situated between the rectum and bladder, called vesiculæ seminales. In *Observations on Certain Parts of the Animal Economy*, 2nd ed., pp. 31-51. London.
- HURLOCK, B., AND TALALAY, P. 1958.  $3\alpha$ -Hydroxysteroids as coenzymes of hydrogen transfer between di- and triphosphopyridine nucleotides. *J. Biol. Chem.*, **233**, 886-893.
- HURLOCK, B., AND TALALAY, P. 1959. Mitochondrial  $3\alpha$ - and  $11\beta$ -hydroxysteroid dehydrogenases. *Arch. Biochem. Biophys.*, **80**, 468-470.
- JACOBSSON, L. 1950. Free amino acids in human semen. *Acta physiol. scandinav.*, **20**, 88-90.
- JEFFREE, G. M. 1957. Some effects of hydroxyl compounds on prostatic acid phosphatases. *Biochim. et Biophys. Acta*, **23**, 155-161.
- JOËL, C. A. 1942. *Studien am menschlichen Sperma*. Basel: Benno Schwabe & Company.
- JOST, A. AND GELOSO, J. P. 1954. Recherche de l'activité androgène de la surrénale par la greffe sur la vésicule séminale de rats castrés. *Compt. rend. Soc. biol.*, **148**, 474-477.
- KAHANE, E. 1937. La choline en biochimie. *Bull. Soc. Chim. Biol.*, **19**, 206-233.
- KAHANE, E., AND LEVY, J. 1936. Origine de la choline du sperme. *Compt. rend. Acad. Sc.*, **202**, 2168-2188.
- KATSH, S. 1950. The androgenic activity of ovarian transplants to the seminal vesicle of the adult male rat. *Endocrinology*, **47**, 370-383.
- KATSH, S. 1959. Scrotin and histamine in human ejaculate. *J. Urol.*, **81**, 570-572.
- KATSH, S., GORDON, A. S., AND CHARIPPER, H. A. 1948. The andromimetic action of adrenal cortical transplants to the seminal vesicle of the adult rat. *Anat. Rec.*, **101**, 47-57.
- KELLERMAN, G. M. 1955. The metabolism of the seminal vesicle of the guinea pig. IV. The role of hexokinase and phosphatase in the formation of seminal fructose. *Australian J. Exper. Biol. & M. Sc.*, **33**, 579-592.
- KIMMIG, J., AND SCHÜRREN, C. 1956. Klimische und biochemische Untersuchungen zum Nachweis von Inosit in Gegenwart von Fructose am menschlichen Sperma. *Hautarzt*, **7**, 198-199.
- KING, T. E., AND MANN, T. 1958. Sorbitol dehydrogenase in spermatozoa. *Nature, London*, **182**, 868-869.
- KING, T. E., AND MANN, T. 1959. Sorbitol metabolism in spermatozoa. *Proc. Roy. Soc. London, ser. B*, **151**, 226-243.
- KING, T. E., ISHERWOOD, F. A., AND MANN, T. 1958. Sorbitol in semen. In *Proceedings IVth International Congress of Biochemistry*, p. 77. New York: Pergamon Press, Inc.
- KORENCHESKY, V. 1937. The female prostatic gland and its reaction to male sexual compounds. *J. Physiol.*, **90**, 371-376.
- KORENCHESKY, V., AND DENNISON, M. 1935. Histological changes in the organs of rats injected with oestrone alone or simultaneously with oestrone and testicular hormone. *J. Path. & Bact.*, **41**, 323-337.

- KORENCHIEVSKY, V., AND DENNISON, M. 1936. The histology of the sex organs of ovariectomized rats treated with male or female sex hormone alone or with both simultaneously. *J. Path. & Bact.*, **42**, 91-104.
- KUHLMAN, R. E. 1954. Hexose-6-phosphatase activity in the seminal vesicles and prostate gland of the rat. *Proc. Soc. Exper. Biol. & Med.*, **85**, 458-460.
- KUTZROK, R., AND LIEB, C. 1931. Biochemical studies on human semen. II. The action of semen on the human uterus. *Proc. Soc. Exper. Biol. & Med.*, **28**, 268-272.
- KUTSCHER, W., AND PANY, J. 1938. Prostataphosphatase. III. Mitteilung. *Ztschr. Physiol. Chem.*, **255**, 169-189.
- KUTSCHER, W., AND WOLBERGS, H. 1935. Prostataphosphatase. *Ztschr. Physiol. Chem.*, **236**, 237-240.
- KUTSCHER, W., AND WÖRNER, A. 1936. Prostataphosphatase. II. Mitteilung. *Ztschr. Physiol. Chem.*, **239**, 109-126.
- LACASSAGNE, A. 1933. Métaplasie épidermoïde de la prostate provoquée chez la souris par des injections répétées de fortes doses de folliculine. *Compt. rend. Soc. biol.*, **113**, 590-592.
- LACASSAGNE, A., AND RAYNAUD, A. 1937. Résultats obtenus dans l'étude de la réaction de l'épithélium de la vésicule séminale à la testostérone, par l'injection de l'hormone dans la lumière de la glande. *Compt. rend. Soc. biol.*, **126**, 578-581.
- LAKE, P. E. 1937. The male reproductive tract of the fowl. *J. Anat.*, **91**, 116-129.
- LANDAU, R. L., AND LOUGHEAD, R. 1951. Seminal fructose concentration as an index of androgenic activity in man. *J. Clin. Endocrinol.*, **11**, 1411-1421.
- LANE-ROBERTS, C., SHARMAN, A., WALKER, K., AND WIESNER, B. P. 1939. *Sterility and Impaired Fertility*. London: Baillière Tindall.
- LARSON, B. L., AND SALSBURY, G. W. 1953. The reactive reducing components of semen; the presence of sulfite in bovine semen. *J. Biol. Chem.*, **201**, 601-608.
- LARSON, B. L., AND SALSBURY, G. W. 1954. The proteins of bovine seminal plasma. I. Preliminary and electrophoretic studies. *J. Biol. Chem.*, **206**, 741-749.
- LARSON, B. L., GRAY, R. S., AND SALSBURY, G. W. 1951. The proteins of bovine seminal plasma. II. Ultracentrifugal and immunological studies and comparison with blood and milk serum. *J. Biol. Chem.*, **211**, 43-52.
- LASNITZKI, I. 1951. Precancerous changes induced by 20-methylcholanthrene in mouse prostates grown *in vitro*. *Brit. J. Cancer*, **5**, 345-352.
- LASNITZKI, I. 1954. The effect of estrone alone and combined with 20-methylcholanthrene on mouse prostate glands grown *in vitro*. *Cancer Res.*, **14**, 632-639.
- LASNITZKI, I. 1955a. The effect of testosterone propionate on organ cultures of the mouse prostate. *J. Endocrinol.*, **12**, 236-240.
- LASNITZKI, I. 1955b. The influence of a hyper-vitaminosis on the effect of 20-methylcholanthrene on mouse prostate glands grown *in vitro*. *Brit. J. Cancer*, **9**, 434-441.
- LASNITZKI, I. 1958. The effect of carcinogens, hormones and vitamins on organ cultures. In *International Review of Cytology*, vol. 7, pp. 79-121. New York: Academic Press, Inc.
- LEBLOND, C. P. 1950. Distribution of periodic acid-reactive carbohydrates in the adult rat. *Am. J. Anat.*, **86**, 1-49.
- LEHMANN, I. 1938. Die Paravaginadrüse von Hemicentetes. *Bio-morphosis*, **1**, 202-227.
- LEONARD, S. L. 1950. Succinic dehydrogenase levels in striated muscle in relation to male hormone. *Endocrinology*, **47**, 260-264.
- LEONE, E. 1953. Uric acid and xanthine oxidase in seminal vesicles. *Boll. Soc. ital. biol. sper.*, **29**, 513-516.
- LEONE, E., AND BONADUCE, L. 1959. Soluble pyridine nucleotide nucleosidase from seminal vesicles. *Biochim. et Biophys. Acta*, **31**, 292-293.
- LEONE, E., AND MANX, T. 1951. Ergothioneine in the seminal vesicle secretion. *Nature, London*, **168**, 205-206.
- LEONE, E., AND SANTOLANCI, P. 1957. Nucleoside phosphorylase and adenosine deaminase of bull seminal vesicles. *Ital. J. Biochem.*, **6**, 212-219.
- LESSER, M. A., VOSE, S. N., AND DIXEY, G. M. 1955. Effect of testosterone propionate on the prostate gland of patients over 45. *J. Clin. Endocrinol.*, **15**, 297-300.
- LEVY, H. A., AND SZEGO, C. 1955a. Metabolic characteristics of the guinea pig seminal vesicle. *Am. J. Physiol.*, **182**, 507-512.
- LEVY, H. A., AND SZEGO, C. 1955b. Effects of castration and androgen administration on metabolic characteristics of the guinea pig seminal vesicle. *Am. J. Physiol.*, **183**, 371-376.
- LEVIN, E., ALBERT, S., AND JOHNSON, R. M. 1955. Phospholipid metabolism during hypertrophy and hyperplasia in rat prostates and seminal vesicles. *Arch. Biochem.*, **56**, 59-65.
- LI, C. H. 1956. Pituitary growth hormone as a metabolic agent. *Science*, **123**, 617-619.
- LIESCHÜTZ, A. 1932. Wiedervermännlichung eines kastrierten männlichen Meerschweinchens nach Eierstockverpflanzung. *Arch. Path. Anat.*, **285**, 35-45.
- LONDON, M., AND HUDSON, P. B. 1953. Studies on the purification of acid prostatic phosphatase. *Arch. Biochem.*, **46**, 141-153.
- LONDON, M., AND HUDSON, P. B. 1955. Identity of phosphotransferase and phosphomonoesterase of human prostate and of sera from patients with prostatic cancer. *Biochim. et Biophys. Acta*, **17**, 185-193.
- LONDON, M., SOMMER, A., AND HUDSON, P. B. 1955. Further studies on the purification of prostatic acid phosphatase. *J. Biol. Chem.*, **216**, 81-95.
- LOSTROTH, A. J., AND LI, C. H. 1956. La acción de la hormona de crecimiento y de la hormona

- laetogénica hipofisiarias sobre los órganos sexuales accesorios de ratas machos castradas e hipofisoprivas. *Rev. argent. Endocrinol. Metab.*, **2**, 213-219.
- LOSTROTH, A. J., AND LI, C. H. 1957. Stimulation of the sex accessories of hypophysectomized male rats by non-gonadotrophic hormones of the pituitary gland. *Acta endocrinol.*, **25**, 1-16.
- LOSTROTH, A. J., SQUIRE, P. G., AND LI, C. H. 1958. Bioassay of interstitial cell-stimulating hormone in the hypophysectomized male rat by the ventral prostate test. *Endocrinology*, **62**, 833-842.
- LOWLSLEY, O. S. 1912. The development of the human prostate gland with reference to the development of other structures at the neck of the bladder. *Am. J. Anat.*, **13**, 299-349.
- LUNDBQUIST, F. 1946. Function of prostatic phosphatase. *Nature, London*, **158**, 710-711.
- LUNDBQUIST, F. 1947a. Studies on the biochemistry of human semen. I. The natural substrate of prostatic phosphatase. *Acta physiol. scandinav.*, **13**, 322-333.
- LUNDBQUIST, F. 1947b. Studies on the biochemistry of human semen. II. Some properties of prostatic phosphatase. *Acta physiol. scandinav.*, **14**, 263-275.
- LUNDBQUIST, F. 1949. Aspects of the biochemistry of human semen. *Acta physiol. scandinav., Suppl.* **66**, **19**, 7-105.
- LUNDBQUIST, F. 1952. Studies on the biochemistry of human semen. IV. Amino acids and proteolytic enzymes. *Acta physiol. scandinav.*, **25**, 178-187.
- LUNDBQUIST, F. 1953. Glycerophosphorylcholine as a precursor of free choline in mammalian semen. *Nature, London*, **172**, 587-588.
- LUNDBQUIST, F., AND SEDORF, H. H. 1952. Pepsinogen in human seminal fluid. *Nature, London*, **170**, 1115-1116.
- LUNDBQUIST, F., THORSTEINSSON, T., AND BUTS, O. 1955. Purification and properties of some enzymes in human seminal plasma. *Biochem. J.*, **59**, 69-79.
- LUTWAK-MANN, C., AND MANN, T. 1950. Restoration of secretory function in male accessory glands of vitamin B-deficient rats by means of chorionic gonadotrophin. *Nature, London*, **165**, 556-557.
- LUTWAK-MANN, C., MANN, T., AND PRICE, D. 1949. Metabolic activity in tissue transplants. Hormone-induced formation of fructose and citric acid in transplants from accessory glands of reproduction. *Proc. Roy. Soc. London, ser. B.*, **136**, 461-471.
- MACLEOD, J., AND SUMMERSON, W. H. 1946. The phosphatase activity of human spermatozoa. *J. Biol. Chem.*, **165**, 533-539.
- MACLEOD, J., AND WRÓBLEWSKI, F. 1958. Lactic dehydrogenase activity in human semen. *Proc. Soc. Exper. Biol. & Med.*, **99**, 265-267.
- MAHONEY, J. J. 1940. The embryology and post-natal development of the prostate gland in the female rat. *Anat. Rec.*, **77**, 375-395.
- MAHONEY, J. J. 1942. Genetic and hormonal determination of prostate development in the female rat. *J. Exper. Zool.*, **90**, 413-439.
- MAHONEY, J. J., AND WITSCHI, E. 1947. Genetics of the female prostate in rats. *Genetics*, **32**, 369-378.
- MANN, T. 1945. Studies on the metabolism of semen. I. General aspects. Occurrence and distribution of cytochrome, certain enzymes and coenzymes. *Biochem. J.*, **39**, 451-458.
- MANN, T. 1946. Studies on the metabolism of semen. III. Fructose as a normal constituent of seminal plasma. Site of formation and function of fructose in semen. *Biochem. J.*, **40**, 481-491.
- MANN, T. 1949. Metabolism of semen. *Advances Enzymol.*, **9**, 329-390.
- MANN, T. 1954a. *The Biochemistry of Semen*. London: Methuen and Company, Ltd.
- MANN, T. 1954b. On the presence of and role of inositol and certain other substances in the seminal vesicle secretion of the boar. *Proc. Roy. Soc. London, ser. B.*, **142**, 21-32.
- MANN, T. 1956. Male sex hormone and its role in reproduction. *Recent Progr. Hormone Res.*, **12**, 353-376.
- MANN, T., AND LEONE, E. 1953. Studies on the metabolism of semen. VIII. Ergothioneine as a normal constituent of boar seminal plasma. Purification and crystallization. Site of formation and function. *Biochem. J.*, **53**, 140-148.
- MANN, T., AND LUTWAK-MANN, C. 1951a. Secretory function of male accessory organs of reproduction in mammals. *Physiol. Rev.*, **31**, 27-55.
- MANN, T., AND LUTWAK-MANN, C. 1951b. Fructose formation and seminal phosphatase. *Biochem. J.*, **48**, xvi.
- MANN, T., AND PARSONS, U. 1950. Studies on the metabolism of semen. VI. Role of hormones. Effect of castration, hypophysectomy and diabetes. Relation between blood glucose and seminal fructose. *Biochem. J.*, **46**, 440-450.
- MANN, T., AND WALTON, A. 1953. The effect of underfeeding on the genital function of a bull. *J. Agric. Sci.*, **43**, 343-347.
- MANN, T., AND WHITE, I. G. 1956. Metabolism of glycerol, sorbitol and related compounds by spermatozoa. *Nature, London*, **178**, 142.
- MANN, T., DAVIES, D. V., AND HUMPHREY, G. F. 1949. Fructose and citric acid assay in the secretions of the accessory glands of reproduction as indicators of male sex hormone activity. *J. Endocrinol.*, **6**, 75-85.
- MANN, T., LEONE, E., AND POLGE, C. 1956. The composition of stallion's semen. *J. Endocrinol.*, **13**, 279-290.
- MANN, T., LUTWAK-MANN, C., AND PRICE, D. 1948. Secretion of fructose and citric acid in transplants of rat seminal vesicle and coagulating gland. *Proc. Soc. Exper. Biol. & Med.*, **68**, 413-415.
- MARTINS, T., AND ROCHA, A. 1929. The seminal vesicles of the castrated mouse, test for testicular hormones. *Suppl. Mem. Instituto Osw. Cruz*, **9**, 196-199.

- MARVIN, H. N., AND AWAPARA, J. 1949. Effect of androgen on concentration of certain amino acids in the rat prostate. *Proc. Soc. Exper. Biol. & Med.*, **72**, 93-95.
- MARX, L. 1931. Versuche über heterosexuelle Merkmale bei Ratten. *Arch. Entwicklungsmech. Organ.*, **124**, 584-612.
- MARX, L. 1932. Zur Anatomie der Prostata weiblicher Ratten. *Ztschr. Zellforsch. mikroskop. Anat.*, **16**, 48-62.
- MATHEWS, J. H. 1941. Notes on the genitalia and reproduction of some African bats. *Proc. Zool. Soc., London*, **111**, 289-346.
- MAWSON, C. A., AND FISCHER, M. I. 1951. Zinc content of the genital organs of the rat. *Nature, London*, **167**, 859.
- MAWSON, C. A., AND FISCHER, M. I. 1952. Carbonic anhydrase and zinc in the prostate glands of the rat and rabbit. *Arch. Biochem.*, **36**, 485-486.
- MAWSON, C. A., AND FISCHER, M. I. 1953. Zinc and carbonic anhydrase in human semen. *Biochem. J.*, **55**, 696-700.
- MCCARTHY, J. F., STEMITA, C. J., JOHNSTON, M. B., AND KILLIAN, J. A. 1928. Biochemical studies of prostatic-vesicular secretions. *J. Urol.*, **19**, 43-55.
- MCDONALD, D. F., AND LATTA, M. J. 1954. Aerobic glycolysis of human benign prostatic hypertrophy slices: inhibition by testosterone. *J. Applied Physiol.*, **7**, 325-328.
- MCDONALD, D. F., AND LATTA, M. J. 1956. Aerobic glycolysis of human prostatic adenoma: *in vitro* inhibition by estrogen and by androgen and estrogen. *Endocrinology*, **59**, 159-164.
- MELAMPY, R. M., AND CAVAZOS, L. F. 1953. Effects of testosterone propionate on histochemical reactions of rat seminal vesicles. *Endocrinology*, **52**, 173-187.
- MELVILLE, D. B., OTKEN, C. C., AND KOVALENKO, V. 1955. On the origin of animal ergothioneine. *J. Biol. Chem.*, **216**, 325-331.
- MILLAR, M. J., ELCOATE, P. V., AND MAWSON, C. A. 1957. Sex hormone control of the zinc content of the prostate. *Canad. J. Biochem. & Physiol.*, **35**, 865-868.
- MIRAND, E. A., AND STAUBITZ, W. J. 1956. Prostatic neoplasms of the Wistar rat induced with 20-methylcholanthrene. *Proc. Soc. Exper. Biol. & Med.*, **93**, 157-162.
- MISLAWSKY, N., AND BORMANN, W. 1899. Die Secretionsnerven der Prostata. *Zentralbl. Physiol.*, **12**, 181-185.
- MOORE, C. R. 1932. Biology of the testis. In *Sex and Internal Secretions*, 1st ed., E. Allen, Ed. Baltimore: Williams & Wilkins Company.
- MOORE, C. R. 1939. Biology of the testis. In *Sex and Internal Secretions*, 2nd ed. E. Allen, C. H. Danforth, and E. A. Doisy, Eds. Baltimore: The Williams & Wilkins Company.
- MOORE, C. R. 1941. On the role of sex hormones in sex differentiation in the opossum (*Didelphys virginiana*). *Physiol. Zool.*, **14**, 1-15.
- MOORE, C. R. 1953. Adrenal cortical secretions in relation to the reproductive system of rats. *J. Clin. Endocrinol.*, **13**, 330-368.
- MOORE, C. R., AND GALLAGHER, T. F. 1930. Seminal vesicle and prostate function as a testis-hormone indicator; the electric ejaculation test. *Am. J. Anat.*, **45**, 39-69.
- MOORE, C. R., AND PRICE, D. 1932. Gonad hormone functions, and the reciprocal influence between gonads and hypophysis with its bearing on the problem of sex-hormone antagonism. *Am. J. Anat.*, **50**, 13-71.
- MOORE, C. R., AND PRICE, D. 1937. Some effects of synthetically prepared male hormone (androstosterone) in the rat. *Endocrinology*, **21**, 313-329.
- MOORE, C. R., AND PRICE, D. 1938. Some effects of testosterone and testosterone propionate in the rat. *Anat. Rec.*, **71**, 59-78.
- MOORE, C. R., AND SAMUELS, L. T. 1931. The action of testis hormone in correcting changes induced in the rat prostate and seminal vesicles by vitamin B deficiency or partial inanition. *Am. J. Physiol.*, **96**, 278-288.
- MOORE, C. R., HUGHES, W., AND GALLAGHER, T. F. 1930. Rat seminal-vesicle cytology as a testis-hormone indicator and the prevention of castration changes by testis-extract injection. *Am. J. Anat.*, **45**, 109-135.
- MOORE, C. R., PRICE, D., AND GALLAGHER, T. F. 1930. Rat-prostate cytology as a testis-hormone indicator and the prevention of castration changes by testis-extract injections. *Am. J. Anat.*, **45**, 71-107.
- MOORE, R. A. 1936. The evolution and involution of the prostate gland. *Am. J. Pathol.*, **12**, 599-624.
- MOORE, R. A. 1943. Benign hypertrophy of the prostate; a morphological study. *J. Urol.*, **50**, 680-710.
- MOORE, R. A., AND MELCHIONNA, R. A. 1937. Production of tumors of the prostate of the white rat with 1:2-benzopyrene. *Am. J. Cancer*, **30**, 731-741.
- MOSSMAN, H. W., LAWLAH, J. W., AND BRADLEY, J. A. 1932. The male reproductive tract of the Sciuiridae. *Am. J. Anat.*, **51**, 89-155.
- NELSON, W. O. 1941. Production of sex hormones in the adrenals. *Anat. Rec., Suppl.*, **81**, 97.
- NESBIT, R. M., AND BAUM, W. C. 1950. Endocrine therapy of prostatic carcinoma: clinical and statistical survey of 1818 cases. *J. A. M. A.*, **143**, 1317-1320.
- NESPOR, E. 1939. Vitamin C im menschlichen Ejaculat. *Klin. Wchenschr.*, **13**, 135.
- NOVALES, R. R., AND BERN, H. A. 1953. Comparative study of three male genital acid phosphatases. *Proc. Soc. Exper. Biol. & Med.*, **84**, 25-28.
- NOWAKOWSKI, H. 1957. Diagnosis and therapy of male hypogonadism. *Acta Endocrinol., Suppl.*, **31**, 117-148.
- NOWAKOWSKI, H., AND SCHIREN, C. 1956. Spermaplasma Fruktose und Leydigzellenfunktion beim Mause. *Klin. Wchenschr.*, **34**, 19-25



- NYDEN, S. J., AND WILLIAMS-ASHMAN, H. G. 1953. Influence of androgens on synthetic reactions in ventral prostate tissue. *Am. J. Physiol.*, **172**, 588-600.
- O'CONNOR, V. J., JR., DESAUTELS, R. E., PRYOR, J. W., MUNSON, P. L., AND HARRISON, J. H. 1959. Studies on hormonal changes in relation to cancer of the prostate: a progress report. *J. Urol.*, **81**, 468-473.
- OETTLER, A. G. 1954. Morphologic changes in normal human semen after ejaculation. *Fertil. & Steril.*, **5**, 227-240.
- ORTIZ, E. 1947. The postnatal development of the reproductive system of the golden hamster (*Cricetus auratus*) and its reactivity to hormones. *Physiol. Zool.*, **20**, 47-66.
- ORTIZ, E. 1953. The effects of castration on the reproductive system of the golden hamster. *Anat. Rec.*, **117**, 65-92.
- ORTIZ, E., BROWN, E. R., AND WILEY, B. E. 1957. The relation of male hormone to phosphatase activity in the seminal vesicle of the guinea pig. *Rév. Suisse Zool.*, **64**, 733-741.
- ORTIZ, E., PRICE, D., WILLIAMS-ASHMAN, H. G., AND BANKS, J. 1956. The influence of androgen on the male accessory reproductive glands of the guinea pig: studies on growth, histological structure and fructose and citric acid secretion. *Endocrinology*, **59**, 179-192.
- OUDEMANS, J. T. 1892. *Die accessorischen Geschlechtsdrüsen der Säugthiere*. Harlem: De Erven Loosjes.
- OVERHOLSER, M. D., AND NELSON, W. O. 1935. The effect of estrin and male hormone injected separately and simultaneously upon the smooth muscle and epithelium of the seminal vesicle in the albino rat. *Anat. Rec.*, **62**, 247-267.
- PAESI, F. J. A., DE JONGH, S. E., AND HOOGSTRA, M. J. 1956. The direct influence of the hypophysis on the prostate and its interference with I.C.S.H. measurements. *Acta Physiol. Pharmacol. neerl.*, **4**, 445-453.
- PALADE, G. E. 1955. A small particulate component of the cytoplasm. *J. Biophys. & Biochem. Cytol.*, **1**, 59-68.
- PARKES, A. S. 1945. The adrenal-gonad relationship. *Physiol. Rev.*, **25**, 203-254.
- PARKES, A. S. 1950. Androgenic activity of the ovary. *Recent Progr. Hormone Res.*, **5**, 101-114.
- PARSONS, U. 1950. Fructose in rabbit semen: a study of normal fluctuations, and changes evoked by testosterone and stilboestrol. *J. Endocrinol.*, **6**, 412-421.
- PASQUALINI, R. Q. 1953. La fonction de la gonadotrofina C (luteotrofina, prolactina) en el macho. *Prensa med. Argent.*, **40**, 2658-2660.
- PEARSON, O. H. 1957. Discussion of Dr. Huggins' paper "Control of cancers of man by endocrinological methods." *Cancer Res.*, **17**, 473-479.
- PÉZARD, A. 1911. Sur la détermination des caractères sexuels secondaires chez les gallinacées. *Compt. rend. Acad. Sc.*, **153**, 1027-1029.
- PFEIFFER, C. A. 1936. Effects of ovarian transplants upon the development and maintenance of the seminal vesicle and the prostate gland of the albino rat. *Anat. Rec.*, **65**, 213-237.
- PHILLIPS, P. H., LARBY, H. A., HEISER, E. E., AND RUPPEL, I. W. 1940. Sperm stimulation in the bull through subcutaneous administration of ascorbic acid. *J. Dairy Sc.*, **23**, 873-878.
- POLLAK, G. J. 1943. Semen and seminal stains. *Arch. Pathol.*, **34**, 140-196.
- PONSE, K. 1948. Actions paradoxales des glandes génitales. *Rév. Suisse Zool.*, **55**, 477-531.
- PONSE, K. 1950. La fonction sexuelle de la cortico-surrénale. *J. Suisse Méd.*, **7**, 170-180.
- PONSE, K. 1954a. Masculinisation paradoxale de rats par des extraits gonadotropes gravidiques en fonction de l'hypophyse et de la surrénale. *Bull. Acad. Suisse Sc. Méd.*, **10**, 1-10.
- PONSE, K. 1954b. *Gonadotrophines chorionique et fonction androgène foivale*. Colloque sur la fonction lutéale, pp. 57-62. Paris: Masson et Cie.
- PONSE, K. 1955. *La fonction androgène de l'ovaire chez l'animal*. Extrait de la III<sup>e</sup> Réunion des Endocrinologistes de Langue Française, pp. 89-138. Paris: Masson et Cie.
- PORTER, J. C., AND MELAMPY, R. M. 1952. Effects of testosterone propionate on the seminal vesicles of the rat. *Endocrinology*, **51**, 412-420.
- PRICE, D. 1936. Normal development of the prostate and seminal vesicles of the rat with a study of experimental post-natal modifications. *Am. J. Anat.*, **60**, 79-127.
- PRICE, D. 1939. Normal development and regression of the prostate gland of the female rat. *Proc. Soc. Exper. Biol. & Med.*, **41**, 580-583.
- PRICE, D. 1941. Rat prostate and seminal vesicle grafts in relation to the age and sex of the hosts. *Physiol. Zool.*, **14**, 145-161.
- PRICE, D. 1942. A comparison of the reactions of male and female rat prostate transplants. *Anat. Rec.*, **82**, 93-113.
- PRICE, D. 1944a. The development of reactivity in the accessory reproductive organs of castrated and spayed rats injected with testosterone propionate. *Physiol. Zool.*, **17**, 377-391.
- PRICE, D. 1944b. The reactivity of the prostate gland of the female rat in relation to age. *Am. J. Anat.*, **75**, 207-231.
- PRICE, D. 1947. An analysis of the factors influencing growth and development of the mammalian reproductive tract. *Physiol. Zool.*, **20**, 213-247.
- PRICE, D., AND INGLE, D. J. 1957. Androgenic effects of autotransplants of adrenals in the accessory reproductive glands of adult castrated rats. *Rév. Suisse Zool.*, **64**, 743-755.
- PRICE, D., AND ORTIZ, E. 1944. The relation of age to reactivity in the reproductive system of the rat. *Endocrinology*, **34**, 215-239.
- PRICE, D., MANN, T., AND LUTWAK-MANN, C. 1949. Some metabolic effects of androgenic substances. *Nature, London*, **164**, 950.
- PRICE, D., MANN, T., AND LUTWAK-MANN, C. 1953.

- The stimulating effect of female hormones on the metabolic activity and histological structure of male rat accessory reproductive glands. *Anat. Rec.*, **122**, 363-380.
- RAUSCHER, H., AND SCHNEIDER, W. 1954. Zur Verwendung des Fructosetests bei der Ratte unter besonderer Berücksichtigung seiner Eignung für den Nachweis schwacher androgener Effekte. *Arch. exper. Path. u. Pharmacol.*, **221**, 447-459.
- RAUTHER, M. 1903. Über den Genitalapparat einiger Nager und Insektivoren, insbesondere die akzessorischen Genitaldrüsen derselben. *Jena Ztschr. Naturwiss.*, **38**, 377-472.
- RAUTHER, M. 1909. Neue Beiträge zur Kenntnis des Urogenitalsystems der Säugetiere. *Denkschr. med.-naturwiss. Ges. Jena*, **15**, 417-466.
- RAYNAUD, A. 1942. Existence de variations dans l'état de développement des tubules glandulaires de la prostate femelle d'*Apodemus sylvaticus* L. *Compt. rend. Acad. Sc.*, **215**, 382-384.
- RAYNAUD, A. 1945. Existence constante de deux lobes prostatiques chez les mulots (*Apodemus sylvaticus sylvaticus*) de sexe femelle. *Bull. Soc. Zool. France*, **70**, 162-172.
- REID, J. T., WARD, G. M., AND SALISBURY, R. L. 1948. Acid and alkaline phosphatase levels in consecutive semen ejaculates from bulls. *Am. J. Physiol.*, **153**, 235-241.
- REIS, J. 1937. Über die Aktivität der 5'-Nukleotidase in den tierischen und menschlichen Geweben. *Enzymologia*, **2**, 183-190.
- REIS, J. 1938. Über die Spezifität der Prostata- und Hodenphosphatase. *Enzymologia*, **5**, 251-253.
- RENOUD, A. E., HASTINGS, A. B., AND NESBETT, F. B. 1954. Studies on carbohydrate metabolism in rat liver slices. III. Utilization of glucose and fructose by liver from normal and diabetic animals. *J. Biol. Chem.*, **209**, 687-696.
- RETEIF, P. J. M. 1949. The accessory glands of reproduction in the male. *Clin. Proc. S. African J. Clin. Sc., Capetown*, **8**, 31-61.
- REŽEK, A., AND ŠIR, S. 1956. Phosphoryleholin und Glycerylphosphoryleholin als Muttersubstanzen des Cholins im Ejakulat des Menschen. *Naturwiss.*, **43**, 304-305.
- RHODES, J. B., AND WILLIAMS-ASHMAN, H. G. 1960. Oxidizing enzymes in human seminal plasma. *Medicina Experimentalis*, **3**, 123-134.
- RIXON, R. H., AND WHITFIELD, J. F. 1959. The histochemical localization of zinc in the dorsal-lateral prostate of the rat. *J. Histochem. & Cytochem.*, **7**, 262-266.
- ROBERTS, S., AND SZEGO, C. M. 1953. Steroid inter-fer-ence in the metabolism of reproductive target organs. *Physiol. Rev.*, **33**, 593-629.
- ROBINSON, J. N., GUTMAN, E. B., AND GUTMAN, A. B. 1939. Clinical significance of increased serum "acid" phosphatase in patients with some metastases secondary to prostatic carcinoma. *J. Urol.*, **42**, 602-618.
- ROSENTHAL, S. M., AND TABOR, C. W. 1956. The pharmacology of spermine and spermidine. Distribution and excretion. *J. Pharmacol. & Exper. Therap.*, **116**, 131-138.
- ROSS, V., MOORE, D. H., AND MILLER, E. G. 1942. Proteins of human seminal plasma. *J. Biol. Chem.*, **144**, 667-677.
- RUBIN, D. 1944. The relation of hormones to the development of Cowper's and Bartholin's glands in the opossum (*Didelphys virginiana*). *J. Morphol.*, **74**, 213-285.
- RUDOLPH, G. G. 1956. Glucose-6-phosphate and 6-phosphogluconate dehydrogenase activities of secondary sex tissues of castrated rats. *Fed. Proc.*, **15**, 158.
- RUDOLPH, G. G., AND SAMUELS, L. T. 1949. Early effects of testosterone propionate on the seminal vesicles of castrate rats. *Endocrinology*, **44**, 190-196.
- RUDOLPH, G. G., AND STARNES, W. R. 1954. Effect of castration and testosterone administration on seminal vesicles and prostates of rats. *Am. J. Physiol.*, **179**, 415-418.
- RUDOLPH, G. G., AND STARNES, W. R. 1955. The effect of testosterone on water distribution of secondary sex glands of male rats. *Endocrinology*, **55**, 682-685.
- SAMUELS, L. T., HARDING, B. W., AND MANN, T. R. 1960. Relation of fructose synthesis in the male accessory sex organs to aldose and ketose reductase activities. *Fed. Proc.*, **19**, 169.
- SAYLES, E. D. 1939. Postnatal development of reproductive system in male guinea pigs and its relation to testis hormone secretion. *Physiol. Zool.*, **12**, 256-267.
- SAYLES, E. D. 1942. The effects of castration upon the reproductive organs of the adult male guinea pig. *J. Exper. Zool.*, **90**, 183-197.
- SCHERSTÉN, B. 1929. Über das Vorkommen der Zitronensäure in Geschlechtsdrüsensekreten. *Skandinav. Arch. Physiol.*, **58**, 90-94.
- SCOTT, E. V. Z., MATTHEWS, W. B., BUTTERWORTH, C. E., JR., AND FROMMEYER, W. B., JR. 1954. Abnormal plasma proteolytic activity. *Surg. Gynec. & Obst.*, **99**, 679-688.
- SCOTT, W. W. 1945. The lipides of the prostatic fluid, seminal plasma, and enlarged prostate gland of man. *J. Urol.*, **53**, 712-718.
- SCOTT, W. W., AND HUGGINS, C. 1942. The acid phosphatase activity of human urine, an index of prostatic secretion. *Endocrinology*, **30**, 107-112.
- SEGALOFF, A., STEELMAN, S. L., AND FLORES, A. 1956. Prolactin as a factor in the ventral prostate assay for luteinizing hormone. *Endocrinology*, **59**, 233-240.
- SEKINE, T. 1951. Choline esterase in pig spermatozoa. *J. Biochem.*, **38**, 171-179.
- SERGIJEWSKY, M., AND BACHROMEJEV, J. R. 1932. Zur Frage der inneren Sekretion der Prostata. *Ztschr. Ges. Exper. Med.*, **81**, 6-12.
- SPEYER, J. 1959. Semen coagulase, a new enzyme. *Fed. Proc.*, **18**, 150.
- SPIEGEL, A. 1939. Über das Auftreten von Geschwülsten der Nebennierenrinde mit vermännlichender Wirkung bei frühkastrierten Me-

- erschweinenmännchen. Arch. path. Anat., **305**, 367-393.
- STAFFORD, R. O., RUBINSTEIN, I. N., AND MEYER, R. K. 1949. Effect of testosterone propionate on phosphatases in the seminal vesicle and prostate of the rat. Proc. Soc. Exper. Biol. & Med., **71**, 353-357.
- STEIN, A. M., KAPLAN, N. O., AND CIOTTI, M. M. 1959. Pyridine nucleotide transhydrogenase. VII. Determination of the reactions with coenzyme analogues in mammalian tissues. J. Biol. Chem., **234**, 979-986.
- STOCKARD, C. R., AND PAPANICOLAOU, G. N. 1919. The vaginal closure membrane, copulation and the vaginal plug in the guinea pig, with further considerations of the oestrus rhythm. Biol. Bull., **37**, 222-245.
- SULLIVAN, T. F., GUTMAN, E. B., AND GUTMAN, A. B. 1942. Theory and application of the serum "acid" phosphatase determination in metastasizing prostatic carcinoma; early effects of castration. J. Urol., **48**, 426-458.
- SWAN, H. T., WOOD, K. F., AND OWEN, D. 1957. Dangerous bleeding associated with carcinoma of the prostate. Brit. Med. J., **1**, 496-498.
- TABOR, C. W., AND ROSENTHAL, S. M. 1956. Pharmacology of spermine and spermidine. Some effects on animals and bacteria. J. Pharmacol. & Exper. Therap., **116**, 139-155.
- TAGNON, H. J., SCHULMAN, P., WHITMORE, W. F., JR., AND LEONE, L. A. 1953. Prostatic fibrinolysin; study of a case illustrating role in hemorrhagic diathesis of cancer in the prostate. Am. J. Med., **15**, 875-884.
- TAKEWAKI, K. 1953. Androgenic activity of intrasplenic ovarian transplants in gonadectomized rats. Annot. Zool. Japon., **26**, 151-155.
- TAKEWAKI, K. 1954. Failure of adrenal transplants to stimulate juxtaposed seminal vesicle transplants in adrenalectomized-castrated rats. Annot. Zool. Japon., **27**, 140-145.
- TALALAY, P., AND WILLIAMS-ASHMAN, H. G. 1958. Activation of hydrogen transfer between pyridine nucleotides by steroid hormones. Proc. Nat. Acad. Sc., **44**, 15-26.
- TALALAY, P., AND WILLIAMS-ASHMAN, H. G. 1960. Participation of steroid hormones in the enzymatic transfer of hydrogen. Recent Progr. Hormone Res., **16**, 1-47.
- TALALAY, P., FISCHMAN, W. H., AND HUGGINS, C. 1946. Chromogenic substrates. II. Phenolphthalein glucuronic acid as substrate for the assay of glucuronidase activity. J. Biol. Chem., **166**, 757-772.
- TALALAY, P., HURLOCK, B., AND WILLIAMS-ASHMAN, H. G. 1958. On a coenzymatic function of estradiol-17 $\beta$ . Proc. Nat. Acad. Sc., **44**, 862-884.
- TAYLOR, S. 1957. Uptake of radioactive zinc *in vitro* by the prostate. Nature, London, **179**, 585.
- THOMPSON, H. 1861. *The Diseases of the Prostate: Their Pathology and Treatment*. 2nd ed. London: J. & A. Churchill, Ltd.
- TINKLEPAUGH, O. L. 1930. Occurrence of a vaginal plug in a chimpanzee. Anat. Rec., **46**, 329-332.
- TISLOWITZ, R. 1939. The action of estrogens in inducing mitoses in the muscle, connective tissue and epithelium of the prostate and seminal vesicle of mice as determined by the colchicine technique. Anat. Rec., **75**, 265-273.
- TRUNNELL, J. B., AND DUFFY, B. J., JR. 1950. The influence of certain steroids on the behavior of human prostatic cancer. Tr. New York Acad. Sc., **12**, 238-241.
- TYLER, E. T. 1955. Seminal fructose studies in infertility. Fertil. & Steril., **6**, 247-256.
- VAN DER LAAN, W. P. 1953. Direct effects of the anterior pituitary on the ventral prostates in rats. J. Clin. Invest., **32**, 609.
- VAN WAGENEN, G. 1936. The coagulating function of the cranial lobe of the prostate gland in the monkey. Anat. Rec., **66**, 411-421.
- VAUQUELIN, L. N. 1791. Expériences sur le sperme humain. Ann. Chim., ser. 1, **9**, 64-80.
- VILLEE, C. A., AND HAGERMAN, D. D. 1958. On the identity of the estrogen-sensitive enzyme of human placenta. J. Biol. Chem., **233**, 42-48.
- VON EULER, U. S. 1934. An adrenaline-like action in extract from the prostate and related glands. J. Physiol., **81**, 102-112.
- VON EULER, U. S. 1936. On the specific vaso-dilating and plain muscle stimulating substances from accessory genital glands in man and certain animals (prostaglandin and vesiglandin). J. Physiol., **88**, 213-234.
- VON EULER, U. S. 1939. Weitere Untersuchungen über Prostaglandin, die physiologisch active Substanz gewisser Genitadrüsen. Skandinav. Arch. Physiol., **81**, 65-80.
- VULPÉ, M., ÜSHER, D., LEBLOND, C. P. 1956. Influence of the extirpation of male accessories on the occurrence of a "soft calculus" in the urinary bladder of the rat. Endocrinology, **59**, 257-259.
- WAGNER-JAUREGG, T. 1941. Über das Vorkommen des Heptakosins im menschlichen Sperma. Ztschr. Physiol. Chem., **269**, 56-58.
- WALKER, G. 1910a. A special function discovered in a glandular structure hitherto supposed to form a part of the prostate gland in rats and guinea-pigs. Bull. Johns Hopkins Hosp., **21**, 182-185.
- WALKER, G. 1910b. The nature of the secretion of the vesiculae seminales and of an adjacent glandular structure in the rat and guinea-pig, with special reference to the presence of histone in the former. Bull. Johns Hopkins Hosp., **21**, 185-192.
- WARD, R. J., AND MOORE, T. 1953. 7-Dehydrosterol in the sexual organs of the rat. Biochem. J., **55**, 295-298.
- WHITE, J. W. 1893. The present position of surgery of the hypertrophied prostate. Ann. Surg., **18**, 152-188.
- WHITMORE, W. F., JR., RANDALL, H. T., PEARSON, O. H., AND WEST, C. D. 1954. Adrenalectomy in the treatment of prostatic cancer. Geriatrics, **9**, 62-69.

- WILLIAMS-ASHMAN, H. G. 1954. Changes in the enzymatic constitution of the ventral prostate gland induced by androgenic hormones. *Endocrinology*, **54**, 121-129.
- WILLIAMS-ASHMAN, H. G. 1955. Respiratory and phosphorylative activities of prostate mitochondria. In *Proceedings 11th International Congress of Biochemistry*, p. 64. Bruxelles: H. Vaillant-Carmanne, S.A.
- WILLIAMS-ASHMAN, H. G., AND BANKS, J. 1954a. The ketose reductase of rat liver and accessory sexual organs. *Arch. Biochem.*, **50**, 513-515.
- WILLIAMS-ASHMAN, H. G., AND BANKS, J. 1954b. The synthesis and degradation of citric acid by ventral prostate tissue. I. Enzymatic mechanisms. *J. Biol. Chem.*, **208**, 337-344.
- WILLIAMS-ASHMAN, H. G., AND BANKS, J. 1956. Participation of cytidine coenzymes in the metabolism of choline by seminal vesicle. *J. Biol. Chem.*, **233**, 509-521.
- WILLIAMS-ASHMAN, H. G., BANKS, J., AND WOLFSON, S. K., JR. 1957. Oxidation of polyhydric alcohols by the prostate gland and seminal vesicle. *Arch. Biochem.*, **72**, 485-494.
- WILLIAMS-ASHMAN, H. G., LIAO, S., AND GOTTERER, G. S. 1958. A direct effect of testosterone on interactions between pyridine nucleotides in male accessory sexual tissues. In *Proceedings 14th International Congress of Biochemistry*, p. 114. Vienna: Pergamon Press.
- WINKLER, F. 1931. Prostata-Studien. *Dermat. Wchnschr.*, **93**, 1626-1631.
- WITSCHI, E., MAHONEY, J. J., AND RILEY, G. M. 1938. Occurrence of prostatic lobes in the female rat. *Biol. Zentralbl.*, **58**, 455-464.
- WOLFSON, S. K., JR., AND WILLIAMS-ASHMAN, H. G. 1958. Enzymatic determination of sorbitol in animal tissues. *Proc. Soc. Exper. Biol. & Med.*, **99**, 761-765.
- WOOLLEY, G. W., AND LITTLE, C. C. 1945a. The incidence of adrenal cortical carcinoma in gonadectomized male mice of the extreme dilution strain. *Cancer Res.*, **5**, 211-219.
- WOOLLEY, G. W., AND LITTLE, C. C. 1945b. The incidence of adrenal cortical carcinoma in male mice of the extreme dilution strain over one year of age. *Cancer Res.*, **5**, 506-509.
- WOTIZ, H. H., AND LEMON, H. M. 1954. Studies in steroid metabolism. I. Metabolism of testosterone by human prostatic tissue slices. *J. Biol. Chem.*, **206**, 525-532.
- WOTIZ, H. H., LEMON, H. M., AND VOULGARPOULOS, A. 1954. Studies in steroid metabolism. II. Metabolism of testosterone by human tissue slices. *J. Biol. Chem.*, **209**, 437-445.
- WÜST, H. 1957. Glykolytische Enzyme im menschlichen Seminalplasma bei Normo-, Oligo- und Azoospermie. *Arch. Klin. Exper. Dermat.*, **205**, 351-356.
- YAMADA, K. 1933. Über den Zuckergehalt des Samens. *Japan. J. Med. Sc. (II. Biochem.)*, **2**, 245.
- YING, S. H., DAY, E., WHITMORE, W. F., JR., AND TAGNON, H. J. 1956. Fibrinolytic activity in human prostatic fluid and semen. *Fertil. & Steril.*, **7**, 80-87.
- YOUNG, D. 1949. Bilateral aplasia of the vas deferens. *Brit. J. Surg.*, **36**, 417-418.
- ZELLER, E. A. 1941. Über das Vorkommen der Diamin-oxydase in menschlichen Sperma. *Helvet. Chim. Acta*, **24**, 117-120.
- ZELLER, E. A., AND JOËL, C. A. 1941. Beiträge zur Fermentchemie des männlichen Geschlechtsapparats. 2. Mitteilung. Über das Vorkommen der Cholinesterase, der Mono- und Diamin-oxydase in Sperma und Prostata, und über die Beeinflussung der Spermien-Beweglichkeit durch Fermentinhibitoren. *Helvet. Chim. Acta*, **24**, 968-976.
- ZIMMÉT, D. 1939. Vitamine C et liquide d'éjaculation du cobaye. Effets sur les caractères généraux de l'éjaculat, les spermatozoïdes et la reproduction. *Compt. rend. Soc. biol.*, **130**, 1476-1479.
- ZORNICHTI, A. W., AND BRENDLER, H. 1958. Studies in semen coagulation. *Proc. Soc. Exper. Biol. & Med.*, **96**, 195-197.
- ZUCKERMAN, S. 1936. The endocrine control of the prostate. *Proc. Roy. Soc. Med.*, **29**, 81-92.
- ZUCKERMAN, S. 1940. The histogenesis of tissues sensitive to oestrogens. *Biol. Rev.*, **15**, 231-271.

# THE MAMMALIAN OVARY

*William C. Young, Ph.D.*

PROFESSOR OF ANATOMY, UNIVERSITY OF KANSAS, LAWRENCE, KANSAS

I. INTRODUCTION	449
II. FOLLICULOGENESIS	451
A. Growth of Primary and Small Vesicular Follicles	451
B. Growth of Vesicular Follicles	455
C. Preovulatory Swelling	455
D. Ovulation	456
E. Folliculogenesis in Pregnancy and Lactation	457
III. CORPUS LUTEUM	459
IV. FOLLICULAR ATRESIA	461
V. HORMONES OF THE OVARY	464
A. Sites of Origin	466
B. Amounts of Hormone Produced	471
VI. AGE OF THE ANIMAL AND OVARIAN FUNCTIONING	476
VII. OTHER ENDOCRINE GLANDS AND THE OVARIES	478
A. Thyroid	478
B. Adrenal Cortex	480
VIII. CONCLUDING REMARKS	483
IX. REFERENCES	484

## I. Introduction

Despite the impetus given to the study of ovarian structure and physiology by the work of Edgar Allen and Edward A. Doisy in the 1920's, knowledge of the mammalian ovary has hardly progressed beyond a descriptive phase. This cannot be attributed to lack of effort, although it must be realized that the ovary as an object of investigation has not held its own with the hypophysis, the thyroid, the adrenal, and the testis. Nor has there been any failure to apply new techniques to the many problems of ovarian structure and physiology. Histochemical and cytochemical techniques were seized upon for what they might contribute to the problem of the site of hormone production,<sup>1</sup> and,

in at least one series of studies (Zachariae, 1957, 1958; Zachariae and Jensen, 1958; Jensen and Zachariae, 1958), to the mechanism of ovulation. Methods for obtaining blood from the ovarian vein have been devised (Paschkis and Rakoff, 1950; Rakoff and Cantarow, 1950; Neher and Zarrow, 1954; Edgar and Ronaldson, 1958) and refined techniques for the assay of secreted estrogens and progesterone have been developed (Reynolds and Ginsburg, 1942; Hooker and Forbes, 1947; Emmens, 1950a, b; Haslewood, 1950; Wolstenholme, 1952; Zander and Simmer, 1954; Brown, 1955; Loraine, 1958; Sommerville and Deshpande, 1958). The collection of follicles and corpora lutea timed more accurately with respect to the moment of ovulation has become possible, and distinction between the normal and the pathologic has become clearer (Deane, 1952). Recently, the electron microscope has been found to have a place, in an investigation of the finer structure of the cells of the corpus luteum (Lever, 1956), in the unraveling of the processes whereby the zona pellucida is formed around the developing oocyte (Chiquoine, 1959; Odor, 1959), and in studies of ovarian oocytes and unfertilized tubal ova (Odor, 1960; Odor and Renninger, 1960) (see Figs. 14.6 to 14.8). As Villee has indicated in his chapter, great strides have been taken toward an understanding of the metabolic pathways in estrogen and progesterone synthesis and degradation.

Two factors may have contributed to the

<sup>1</sup>Dempsey and Bassett, 1943; Dempsey, 1948; Claesson, 1954; Claesson and Hillarp, 1947a-c; Claesson, Diezfallusy, Hillarp and Högberg, 1948; Claesson, Hillarp, Högberg, and Hökfelt, 1949;

McKay and Robinson, 1947; Meyer and McShan, 1950; Barker, 1951; Røckenschaub, 1951; White, Hertz, Rock and Adams, 1951; Deane, 1952; Nishizuka, 1954; Ford and Hirschman, 1955; Noach and van Rees, 1958.

disappointment that has been expressed. First, the purification and synthesis of the hormones in the 1930's (Allen, 1939; Doisy, 1939) and the later successful development of synthetic estrogens and gestagens (Solmsen, 1945; Dodds, 1955; Rock, Garcia and Pineus, 1956; St. Whitelock, 1958) provided a means whereby much of ovarian physiology could be studied out of context with the processes by which this organ functions. Specifically, there are many effector actions of ovarian hormones, many interrelationships with other hormones and with each other, many problems of tissue responsiveness, and many questions bearing on processes of ovarian hormone metabolism, all of which can be studied in ovariectomized animals.

Secondly, there were many practical reasons why chemists should have striven to synthesize estrogenic substances and gestagens which are suitable for replacement therapy. Once prepared, these synthetic substitutes are of interest, but their development and therapeutic application may well have diverted attention from studies of the ovary.

If there is disappointment with the progress that has been recorded, we would direct attention to substantial accomplishments which should stand us in good stead in the future. Among these are the numerous careful descriptions of the growth and maturation of ovarian follicles and the meticulous accounts of corpus luteum formation, structure, and involution. In a general way it has become clear that in many species estrogen and progesterone are produced while the follicles are maturing, and that, during the functional life of the corpus luteum, progesterone and estrogen are secreted. Estimates of the amounts produced have been numerous and of more than ordinary interest. In addition, they probably represent steps toward the determination of additional important information: the day-to-day rate of production correlated with the growth of the follicles and the development of the corpora lutea, and, in species in which variable numbers of follicles and corpora lutea develop, steps in an effort to ascertain whether, for example, 10 follicles in an individual produce more hormone than 5. This knowledge, if we possessed it, might

contribute significantly to current theories of gonadal-pituitary relationships because thresholds are involved in the regulatory processes (see chapters by Everett and Greep).

It could be disappointing that, on the basis of evidence which is largely circumstantial and inferential, almost every tissue component of the ovary, membrana granulosa, theca interna, and interstitial cells, has been claimed to be the source of estrogen and progesterone. But it is encouraging that information has been obtained which prompts us to recognize that it may be futile and unrealistic to attempt to identify specific cell types as the sources of hormones in the ovary. Current thought, stimulated by the discovery that testicular cells, placental tissue, and occasionally the adrenal cortex are sources of estrogen and progesterone, and that ovarian tissue produces androgens, is leaning toward the view that the several tissues involved in steroid hormone biosynthesis may be subject to metabolic aberrations which change their hormone production either in rate or in kind. The approach to the problem now seems to be through enzymatic biochemistry rather than through gross or finer morphology. Examples of this approach which are suggestive for further work on the ovaries are provided by the numerous studies by Samuels and his associates (Samuels, Helmreich, Lasater and Reich, 1951; Huseby, Samuels and Helmreich, 1954; Beyer and Samuels, 1956; Samuels and Helmreich, 1956; Shaunwhite and Samuels, 1956).

It is known in a general way that follicular maturation, ovulation, and corpus luteum formation are controlled by gonadotrophic hormones from the pituitary. However, as Greep emphasizes in his chapter, the specific gonadotrophic hormones have not yet been isolated and identified, nor have their specific roles in ovarian physiology been demonstrated. To be sure, ovulation has been reported following the injection of allegedly purified pituitary gonadotrophins into hypophysectomized rats (Velardo, 1960), but until stages normally seen in the process of folliculogenesis and ovulation can be reproduced consistently by the use of pituitary gonadotrophins, and until target organ responses simi-

lar to those in intact cycling animals are being evoked, no satisfactory conceptualization of ovarian functioning will be possible.

Chorionic gonadotrophins are not without practical value in the stimulation of ovulation (Cole and Miller, 1933; Folley and Malpress, 1944; Folley, Greenbaum and Roy, 1949; Marden, 1951; Umbaugh, 1951; Robinson, 1954; and others); nevertheless, their contribution to ovarian physiology may be limited. Bradbury has pointed out in a personal communication that the human placental hormone (HCG) is exotic for laboratory animals. It has practically no effect on the ovaries of guinea pigs or field mice. In rats its biologic effects are quite different from those of pituitary luteinizing hormone (LH) or interstitial cell-stimulating hormone (ICSH) (Selye, Collip and Thomson, 1935; Evans, Simpson, Tolksdorf and Jensen, 1939). HCG is so ineffective in the hypophysectomized rat that it has been assumed, in the case of the intact animal, either that it acts through the pituitary or that it requires the presence of the pituitary to be effective (Asehheim, Portes and Mayer, 1939; Noble, Rowlands, Warwick and Williams, 1939). If HCG and other chorionic gonadotrophins are exotic, as such results would indicate, the extrapolation of effects which have followed their use to the normal functioning of the ovary could be seriously misleading.

What we have written is intended to set the tone for what follows. Many of the solid accomplishments of the past two decades will be recounted, but the areas of uncertainty and the difficulties which slowed down the progress of the twenties and thirties will be enumerated in the hope that the curiosity of a new generation will be aroused and guide us into a period of even more productive effort.

## II. Folliculogenesis

### A. GROWTH OF PRIMARY AND SMALL VESICULAR FOLLICLES

In mammals, by the time of birth, oogonia have completed their proliferative activity and become primary oocytes. The serosal surface of the ovary is covered by a layer of cells known as the germinal epithelium. There has been and still is considerable

speculation whether adult germinal epithelium contains, or gives rise to, any germ cells (Sneider, 1940; Mandl and Zuckerman, 1950, 1951a-d, 1952b; Zuckerman, 1951; Green and Zuckerman, 1951). The subject is reviewed extensively by Brambell (1956) and in the chapter by Blandau. Careful studies of human ovaries have been made by Bloek (1951a, b, 1952, 1953). From all this material, it is clear that a satisfactory answer has not been given. The latter may be awaiting the development of a fresh approach and until then another review of the many conflicting reports and opinions would be repetitious.

More relevant to the present review is the relationship between ovarian estrogens, on the one hand, and germ cell proliferation and follicle development, on the other. It has been claimed that exogenous estrogen stimulates mitotic activity in the germinal epithelium in mice, rats, and the minnow, *Phoxinus phoxinus* L. (Bullough, 1942a, 1943; Stein and Allen, 1942; de Wit, 1953; von Burkl, Kellner, Lindner and Springer, 1954). Bullough (1943) suggested that new cycles of oogenesis are initiated by estrogen in the follicular fluid of large and rupturing follicles. Mandl and Zuckerman (1950) and Dornfeld and Berrian (1951) were less certain. The former expressed the belief that the direct effect of estrogenic stimulation cannot be measured by comparing the total number of oocytes in the ovary. The latter, after finding that isotonic saline, gelatine, or agar injected into the perovarian capsules of immature rats elicited mitoses in the germinal epithelium, concluded that the reaction was in response to injury rather than to the substance injected. Notwithstanding the precautionary notes sounded by Mandl and Zuckerman and by Dornfeld and Berrian, the number of reports of increased mitotic activity near the site of ovulation or when estrogen is placed in contact with the germinal epithelium remains impressive. Particularly because of the analogy with the androgenic control of spermatogenesis pointed out by Bullough (1942b) and others, the possibility should be tested further.

As the oocyte starts to grow, the flat investing cells proliferate and form the membrana granulosa. By the time the rat oocyte has completed its growth it has acquired

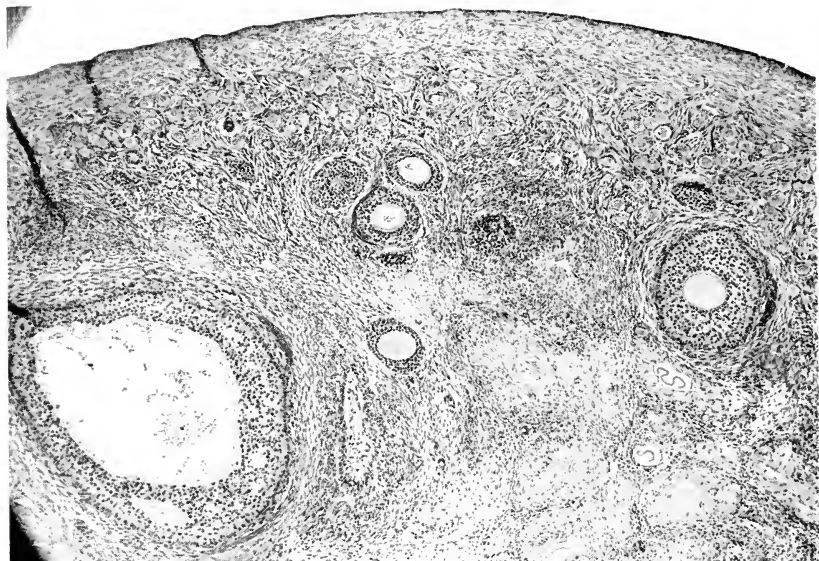

FIG. 7.1. Monkey hypophysectomized 1 year previously. Follicles are in progressive stages of development. Concentration of oocytes in the cortex resembles that in fetal or juvenile ovaries. No evidence of estrogen production in this animal. (Courtesy of Dr. Ernest Knobil.)

four layers of granulosa cells (Mandl and Zuckerman, 1952a). The increase in size of the growing follicle is relatively constant until the stage of antrum formation (Paesi, 1949a). Follicles grow and develop to this stage in rats and guinea pigs even after hypophysectomy (Dempsey, 1937; Paesi, 1949b). It is thus apparent that the gonadotrophic hormones of the pituitary are not essential for the early growth of ovarian follicles (Fig. 7.1). The rate of this early follicular growth may, however, be accelerated in the presence of certain, but perhaps not all, gonadotrophic hormones (Pencharz, 1940; Simpson, Evans, Fraenkel-Conrat and Li, 1941; Gaarenstroom and de Jongh, 1946; Payne and Hellbaum, 1955).

As the granulosa of the growing follicle proliferates, the surrounding tissue differentiates into theca interna. Dubreuil (1942, 1948, 1950) postulated that the granulosa produces an inductor substance which causes the differentiation of the theca interna. Hisaw (1947), in a review of the literature bearing on this point, also suggested that there must be organizers within

the developing granulosa cells which stimulate differentiation of the theca interna. Furthermore, this autonomous process continues until the follicle reaches a stage of development at which it becomes responsive to gonadotrophic hormones. Hisaw called this the stage of "competency."

Somewhere in this process estrogens seem to have a role, or, if the opinions expressed by Bullough (1943) and the other investigators whose work has just been cited can be confirmed, perhaps there is a continued stimulation by these substances. If large doses of estrogen are administered to immature or to hypophysectomized immature rats, many follicles develop to the early antrum stage within 72 hours. The theca interna differentiates around these estrogen-stimulated follicles. When immature rats are given large doses of estrogen there is a definite increase in ovarian weight and in the number of medium-sized follicles (Fig. 7.2); small amounts, on the other hand, are inhibitory (Paesi, 1952). Increased growth of large follicles, or at least a retardation of their degeneration, has



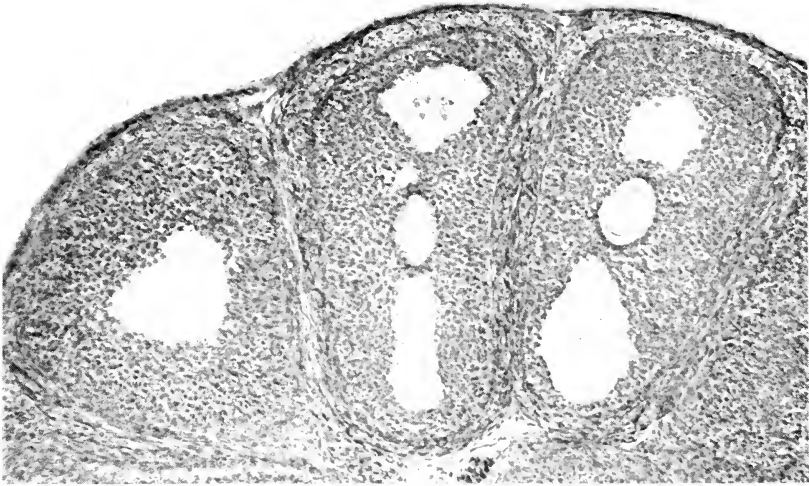

FIG 72. Intact immature rat given estrogen for 3 days. Active proliferation of granulosa in many follicles. Decreased incidence of atresia and hypertrophy of theca. (Courtesy of Dr. J. T. Bradbury.)

been reported in hypophysectomized rats given stilbestrol (Pencharz, 1940; Williams, 1944; Desclin, 1949; Payne and Hellbaum, 1955; Ingram, 1959). Histologically, when estrogen is given, there is a marked increase in mitotic activity of the granulosa cells and a decrease in atresia (Williams, 1945a; de Wit, 1953; Payne and Hellbaum, 1955; Payne, Hellbaum and Owens, 1956; Williams, 1956). The fact that estrogen stimulates the follicle and protects it against atresia suggests that the granulosa is not a significant source of estrogen. On the other hand, if estrogen is produced by the theca interna, it could exert a localized stimulatory action on the membrana granulosa (Corner, 1938; Bullough, 1942b, c, 1943). The differentiation and development of the theca interna is nicely timed for a localized production of estrogen around each Graafian follicle.

Estrogen not only stimulates the granulosa to proliferate, but also renders the follicles more responsive to exogenous gonadotrophins. Williams (1945b) found that the ovary in the stilbestrol-treated hypophysectomized rat was more responsive to small doses of pregnant mare serum (PMS) than was the ovary in the intact

immature rat. Payne and Runser (1958) found that stilbestrol augmented the response of hypophysectomized immature rat ovaries to exogenous pituitary extracts. In Bradbury's experience at Iowa 48 hours of stilbestrol pretreatment rendered the ovaries of both intact immature and hypophysectomized rats more responsive to Armour's LH (Lot No. R377242H), but not to Armour's follicle-stimulating hormone (FSH) (AL 1027). Furthermore, increasing the dosage of stilbestrol from 0.02 mg. to 0.2 mg. markedly increased the response of the ovaries to a given dose of LH. He suggested that the possibility should be explored that the local (perifollicular) concentration of estrogen determines the responsiveness of the maturing follicles. Thoughtful discussions of the subject are given by Paesi (1952) and by Bradbury (1961). The former suggested that 2 or 3 types of estrogen action may be involved in the stimulation of the ovary which is seen when estrogen is administered. Bradbury applied estradiol or stilbestrol to one ovary of the immature rat, leaving the other ovary untreated. The various unilateral responses—increase in weight, formation of corpora lutea, greater reactivity to gonadotrophins—demonstrated

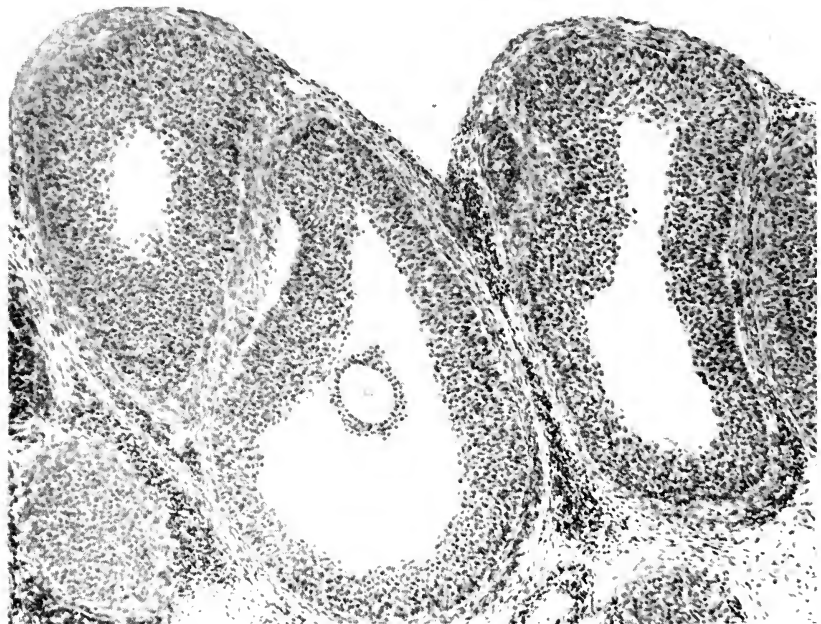

Fig. 7.3. Immature hypophysectomized rat treated with Armour's FSH. Granulosa has proliferated and follicles have developed antra. The theca is differentiated but the interstitium is deficient. (Courtesy of Dr. R. M. Melampy.)

clearly the local stimulating effect of estrogens with the ovary, as well as the systemic effect by way of the pituitary.

If estrogen administration to immature or to hypophysectomized immature rats is continued 7 to 10 days, the granulosa of the stimulated follicles degenerates. This atretic process differs from natural atresia in that it seems to start peripherally rather than centrally. The oocytes do not fragment or give off polar bodies as frequently as do oocytes in normally atretic follicles. It seems that the stimulatory effect of estrogen on the granulosa is very temporary. Its duration, however, is long enough to be compatible with the normal process of maturation and ovulation.

Before concluding the subject, a certain amount of back-tracking may be desirable. One of the first suggestions to be made by Edgar Allen (1922; see also the biographical sketch in this book) was that the ovum is

the dynamic center of the follicle. If the suggestion is placed in the context that has since been developed, the sequence of events would be an inductive influence of the oocyte on the membrana granulosa, a continued inductive influence (oocyte or membrana granulosa?) on the surrounding connective tissue cells until the theca interna is formed,<sup>2</sup> and then the secretion of estro-

<sup>2</sup> Results obtained by Genter (1931), Schmidt (1936), Humphreys and Zuckerman (1954), and Westman (1958) suggest that a similar functional relationship exists between the granulosa and interstitial cells. According to Genter, x-ray-injured ovaries composed of interstitial cells produced estrogen only if a growing follicle was present. The involuted condition of the uteri in rabbits in which all oocytes and follicles had been destroyed by x-rays led Humphreys and Zuckerman to conclude that the ovaries of these animals were not producing estrogen. The results reported by Westman suggested that interstitial cell function continues only for a limited period after x-ray-induced degeneration of the granulosa cells. The results from an ingenious investigation by Ingram (1957) are

gen which feeds back to stimulate further growth of the membrana granulosa and follicle.

Attractive as such a hypothesis is, it has at least one weakness. If gonadotrophic extract rich in FSH is administered to immature rats for three days, there is a generalized stimulation of granulosa tissue (Fig. 7.3). Small follicles increase in size, medium sized follicles develop an antrum, and Graafian follicles become large and vesicular (Parkes, 1943), but ovulation is uncommon. At autopsy the ovaries are pale and edematous. The ovaries are markedly increased in size from numerous follicles becoming vesicular. Histologically there is little stimulation of the theca interna. Gaarenstroom and de Jongh (1946) recognized this ovarian response when they suggested that FSH be designated as Ge (gonadotrophin epithelial). This tissue response offers evidence that FSH is primarily concerned with growth and proliferation of the granulosa cells, but there is no explanation to account for the failure of these granulosa cells to stimulate the differentiation of the theca interna and the eventual secretion of estrogens.

During all of follicular growth, the presence of estrogen has come to be assumed and its production by the growing follicle is thought to begin with the appearance of the theca interna (see below). On the other hand, the amount produced and the rate of production are unknown. The amount must increase with the growth of the follicles. Gillman and Gilbert (1946) found during their investigation of perineal turgescence in the baboon that, once the perineum reaches maximal turgescence, additional estrogen is required to maintain it. They concluded that in normal animals, during the second part of the phase of turgescence, there must be an increased output of ovarian estrogen. Direct studies have yielded little

similarly suggestive. Autografts of ovarian medulla without cortical tissue or oocytes, and autografts of cortical tissue were transplanted to various sites in sexually mature rabbits. The grafts of cortical tissue persisted after the medullary grafts had disappeared. Ingram concluded that medullary tissue containing interstitial tissue but no follicles cannot survive.

information. Ford and Hirschman (1955) estimated alkaline phosphatase activity in the ovary of the rat, but the concentrations in the theca interna and ovarian tissue as a whole were relatively constant during the phases of the cycle.

#### B. GROWTH OF VESICULAR FOLLICLES

The growth of the follicle which is dependent on stimulation by hypophyseal gonadotrophins has been described for a number of animals and, for a few (cow, sow, ewe, guinea pig, rat) plotted with respect to the time of the preceding ovulation (McKenzie, 1926; Hammond, 1927; Grant, 1934; Myers, Young and Dempsey, 1936; Boling, Blandau, Soderwall and Young, 1941; von Burkl and Kellner, 1956). Data of the latter sort are especially valuable for the baselines they provide for experimental studies of the factors affecting the pituitary-gonadal relationships. Deviations in the shape of the curve of follicular growth, and disparities in the size of the growing follicles and in the size and structure of the corpora lutea, are clear indicators of abnormalities in function which have been too little used.

#### C. PREOVULATORY SWELLING

Without exception in the animals listed above, and probably in the horse, goat, and bat, if we may judge from the data presented by Hammond and Wodzicki (1941), Wimsatt (1944), and Harrison (1946, 1948b), a linear period of growth during most of the diestrus is followed by a positive acceleration (preovulatory swelling); shortly before estrus and ovulation. The point at which this acceleration occurs is the point in the development of the follicle where physiologic evidence for the production of progesterone by the unruptured follicle was first found (Dempsey, Hertz and Young, 1936; Astwood, 1939). As we will see later, however, the "moment" the preovulatory swelling begins is not necessarily the point in time when the first progesterone is produced.

In most species in which the course of the preovulatory swelling has been followed, it is a 10- to 12-hour process (Hammond, 1927; Grant, 1934; Myers, Young and

Dempsey, 1936; Boling, Blandau, Soderwall and Young, 1941; Rowlands and Williams, 1943; Rowlands, 1944), although in the cat and ferret the process is triggered by mating and extends over 25 to 30 hours. The preovulatory swelling can be initiated by injecting gonadotrophins of the LH or ICSH type, but they are effective only on well matured follicles (Hisaw, 1947; Talbert, Meyer and MeShan, 1951). The younger follicles are not stimulated and, on the contrary, they may show an accelerated atresia. It could be postulated that the follicles with well developed theca interna were "competent" and that stimulated theca interna produced estrogen which favored the development of these follicles. The smaller follicles were "incompetent" in the absence of a thecal investment and became atretic. If HCG is injected into immature rats, the theca interna around the vesicular follicles hypertrophies within 24 hours and these follicles enlarge rapidly. The vasodilation of the theca blood vessels is grossly evident within a few hours (Kupperman, MeShan and Meyer, 1948; Sturgis and Politon, 1951; Odeblad, Nati, Selin and Westin, 1956).

Explanation has been sought for the nature of the changes within the follicle which lead to the accelerated enlargement culminating in ovulation. Studies of the staining qualities of such follicles reveal that the metachromatic polysaccharides of the granulosa (hyaluronic acid and chondroitin sulfuric acid) become progressively depolymerized and orthochromatic. This hydrolysis of the mucopolysaccharides gives rise to an increased osmolarity which may be the major factor in the preovulatory swelling of the follicle (Harter, 1948; Catchpole, Gersh and Pan, 1950; Odeblad, 1954; Zachariae, 1958; Zachariae and Jensen, 1958; Jensen and Zachariae, 1958). Accompanying the swelling is a dispersal of the cells of the cumulus oophorus. This may be a consequence of the breakdown of the intercellular substance in the stimulated membrana granulosa.

The time required for follicular growth and maturation from the stage when its further development is dependent on pituitary gonadotrophin stimulation to ovulation is related to the length of the cycle and

therefore varies greatly from species to species. Somewhat less than 4 to 5 days are required in the rat (Boling, Blandau, Soderwall and Young, 1941), somewhat less than 16 days in the guinea pig (Myers, Young and Dempsey, 1936), somewhat less than 21 days in the cow (Hammond, 1927), and presumably comparable intervals in other species. Vermande-Van Eck (1956) estimated that in the rhesus monkey the average time required for the growth of a mature follicle from the large follicle without an antrum is 4 to 6 weeks; 11 days are estimated to be necessary for the complete development of a follicle in the rabbit (Desaive, 1948). Ovulation occurred earlier than normal when the corpora lutea from the preceding cycle were removed, but the rate of follicular development was not altered (Dempsey, 1937). Presumptive evidence exists, however, that the rate of growth may be slower in pubescent chimpanzees (Young and Yerkes, 1943), baboons (Gillman and Gilbert, 1946), and guinea pigs (Ford and Young, 1953).

#### D. OVULATION

Ovulation, under normal circumstances, probably is explosive (Hill, Allen and Kramer, 1935, in the rabbit; Blandau, 1955, in the rat). In 1 of 2 human patients Doyle (1951) saw a gush of follicular fluid at the time of ovulation. In 163 ovulations timed by Blandau the interval between the rupture of the stigma and the escape of the ovum was 72 seconds when most of the follicular fluid escaped in advance of the ovum, and 216 seconds when the cumulus oophorus preceded the follicular fluid. The slower, steady, continuous flow of the liquor folliculi which has been described by Walton and Hammond (1928) in the cow, Markee and Hinsey (1936) in the rabbit, and by Doyle (1951) in one human subject could be an artifact of the procedures used in watching the process.

The mechanism leading up to formation of the stigma and rupture of the follicle is unknown. Claesson (1947), using the submicroscopical differences which can be observed in polarized light, distinguished smooth muscle from connective tissue cells and reported that no bundles of smooth muscle or isolated cells were found in the

theca externa in ovaries from the cow, pig, rabbit, and guinea pig. The earlier contradictory results he reviewed were attributed to the nonspecificity of the older staining methods. A possible clue to the mechanism of ovulation which does not seem to have been explored was given by the observations of Boling, Blandau, Soderwall and Young (1941) when they were studying follicular growth in the rat. Immediately before ovulation, but at no other time, a large pocket at the base of the cumulus, and described as an invagination of the granulosa, is a constant feature of follicular structure (Fig. 9 in their article). No guess was made as to its significance.

In all the spontaneously ovulating infra-human mammals that have been studied, except the dog (Evans and Cole, 1931), possibly other Canidae, and the mouse (Snell, Fekete, Hummel and Law, 1940) in which it takes place early in estrus, ovulation occurs toward the end of heat (see reviews in Young, 1941; Dukes, 1943; and more recent articles on the chimpanzee, rhesus monkey, baboon, cow, and mare by Young and Yerkes, 1943; van Wagenen, 1945, 1947; Gillman and Gilbert, 1946; Cordiez, 1949; and Trum, 1950; respectively). Only in the human female in which cyclic waxing and waning of sexual desire is not easily detected does uncertainty exist.

Since an early period, when emphasis was given to the opinion that ovulation occurs about midway in the intermenstrual interval (Knaus, 1935; Hartman, 1936; Farris, 1948), much evidence has been produced indicating that it may occur at other times as well, even during menstruation (Teacher, 1935; Rubenstein, 1939; Sevitt, 1946; Bergman, 1949; Stieve, 1952; and many others). If we may judge from what has been found in the chimpanzee (Young and Yerkes, 1943), baboon (Gillman and Gilbert, 1946), rhesus monkey (Rossman and Bartelmez, 1946), and man (Bergman, 1949; Buxton, 1950), irregularities in the length of the preovulatory and postovulatory phases of the cycle complicate the problem and could account for some of the confusion. In the chimpanzee, baboon, and human female, in which the irregularities can be located with respect to the time of ovulation, age influences the length of both phases, and fol-

lowing pregnancies there are similar irregularities. In the baboon, environmental stresses result in temporary or even prolonged inhibition of ovarian activity. There is no reason for believing that the same factors have less effect on folliculogenesis in the human female; irregularities in adolescence (Engle and Shelesnyak, 1934) and following pregnancy (Sharman, 1950, 1951) are common and there are many reports of psychic effects (see reviews by Kelley, 1942; Kelley, Daniels, Poc, Easser and Monroe, 1954; Kroger and Freed, 1950; Randall and McElin, 1951; Bos and Cleghorn, 1958). In all cases follicular growth is interrupted and amenorrhea follows. But if the estimates are correct that the average fertile woman ovulates normally about 85 per cent of the time (Farris, 1952), or that perfectly healthy women may have 3 or 4 anovulatory cycles a year (de Allende, 1956; also see table in Bergman, 1949), there must also be cases in which much of follicular growth is normal, or at least adequate to stimulate growth changes in the uterus, but ovulation does not occur. As if the complications noted above are not enough, the reviews of the methods used in determining the time of ovulation (D'Amour, 1934; Cohen and Hankin, 1960) and the critical study of Buxton and Engle (1950) in which an attempt was made to correlate basal body temperature, the condition of the endometrium, and the stage of folliculogenesis in the ovary, suggest either that a really sensitive indicator of the time of ovulation has not been found, or if one exists, that it has not been used in a study sufficiently systematic to reveal the true situation in the human female. The problem is one of the many that is with us very much as it was 20 years ago.

#### E. FOLLICULOGENESIS IN PREGNANCY AND LACTATION

Before leaving the subject of follicular growth, its course in pregnancy and lactation should be reviewed. Information has been obtained from many species, but in most cases it is not complete and a considerable amount of conjecture is necessary. What is certain is that pregnancy affects the process of folliculogenesis in many ways; each must be the reflection of a different in-

terrelationship between pituitary, gonads, and placenta. In the mare, and presumably other species in which multiple ovulations occur early in pregnancy, the involvement of chorionic gonadotrophins, pituitary gonadotrophins, and estrogen of placental origin has been suggested (Rowlands, 1949). When folliculogenesis is inhibited just before the stage of the preovulatory swelling, as it is in many pregnant animals (see below), the nervous system may be involved. An unusually significant investigation in which the threshold of stimulation to ovulation in the rabbit was correlated with threshold changes in cerebral activity has recently been completed (Kawakami and Sawyer, 1959). It was demonstrated that pregnancy or prolonged treatment with progesterone maintains the electroencephalogram (EEG) after-reaction threshold to low frequency stimulation of hypothalamic or rhinencephalic nuclei at an elevated level. At this level, gonadotrophin release does not occur in response to coitus or other ovulatory stimuli. The discovery of this fact has provided a basis for understanding the various ovarian conditions associated with pregnancy and lactation, or at least those in which follicular development proceeds to the point of preovulatory swelling and then stops. It may be that some other mechanism of inhibition accounts for the more severe retardation of folliculogenesis in species in which this occurs.

The European hares, *Lepus timidus* L., and *L. cuniculus* L., are reported as mating during pregnancy with the occurrence of superfetation (Lienhart, 1940). Pregnancy, therefore, has little or no effect on any stage of folliculogenesis in these species. The domestic rabbit appears to be somewhat more affected and perhaps more variable. Claesson, Hillarp, Högberg and Hökfelt (1949) state that the ovaries of pregnant rabbits are composed almost entirely of interstitial gland, except for the corpora lutea, but, according to Hammond and Marshall (1925) and Dawson (1946), mature follicles are present and pregnant animals will occasionally mate. However, if we may assume that the reaction of pregnant animals is similar to that of pseudopregnant animals (Makepeace, Weinstein and Friedman, 1938), pituitary gonadotrophin is not

released and ovulation does not occur. From examination of the ovaries and from the fact that fertile matings can occur within a very few hours after parturition (Dempsey, 1937; Boling, Blandau, Wilson and Young, 1939; Blandau and Soderwall, 1941), it is clear that follicular development in the pregnant guinea pig and rat proceeds to a point just short of the preovulatory swelling. According to Nelson (1929) and Swezy and Evans (1930), cycles of oogenesis occur in laboratory rats, and, although the follicles may form small corpora lutea (Swezy and Evans), ordinarily they do not rupture. The musk-rat, *Onychomys leucogaster*, and the African bat, *Myotis lucifugus*, must display an advanced follicular development during pregnancy because there is evidence of postpartum estrus (Warwick, 1940; Matthews, 1941, respectively), Brown and Luther (1951) state that postpartum estrus occurs within 3 days after farrowing in the sow, if the young pigs are removed. We assume, from this latter statement and from the report that estrus and service may occur during pregnancy in this species (Perry and Pomeroy, 1956), that large follicles are present in the ovaries of the pregnant sow.

Heat periods in the pregnant ewe are associated with follicular growth, but ovulation does not occur, and late in pregnancy follicle size decreases significantly (Williams, Garrigou, Norton and Nalbandov, 1956). The first heat after parturition was an average of 23.9 days later, range 1 to 61 days. According to Harrison (1948b), widespread atretic changes can be seen in all the follicles in the goat, beginning the 40th day of pregnancy. By the 60th day, no healthy follicles can be found.

Hammond (1927) was of the opinion that during pregnancy in the cow, follicles develop to the size at which the preovulatory swelling begins, but Dukes (1943), citing a study by Weber, wrote that cows come into heat 3 to 7 weeks after parturition. Support for this view comes from the report by Hafez (1954) that the average interval to the postpartum estrus in another bovine, the Egyptian buffalo, is 43.8 days, range 16 to 76 days. The relatively long postpartum interval in these two species is presumptive evidence that follicles are relatively small at the end of pregnancy in bovines.

Between the 40th and 150th day of pregnancy in the mare the ovaries contain numerous actively growing follicles and several functional corpora lutea (Cole, Howell and Hart, 1931; Rowlands, 1949). However, from the 150th day until the late stages, there is a regression of all the corpora lutea and an absence of large follicles. In the late stages only minute vestiges of corpora lutea and small follicles remain. If the latter is true, follicular growth must be rapid after parturition, because the first heat following foaling was between the 7th and 10th days in 77 per cent of the many mares Trum (1950) studied. In the African elephant, *Loxodonta africana*, there is also a replacement of the corpora lutea (one plus several accessory corpora lutea) about midway through pregnancy (Perry, 1953). Some are formed following ovulation and some not. They persist until term when they involute rapidly. During the late stages of pregnancy no follicles with antra are found. Dawson (1946) wrote that the domestic cat does not possess mature follicles at the time of parturition. In nonlactating animals the pro-estrous level is reached the 4th week after parturition.

Presumptive evidence exists that the follicles in the parturitive chimpanzee are small (Young and Yerkes, 1943). In the human female the appearance of the first ovulatory cycle after pregnancy is irregular (Sharman, 1950, 1951; McKeown, Gibson and Dougray, 1954). According to Sharman, it may occur about 6 weeks after delivery in nonlactating women. This suggests that follicles are small at the end of pregnancy in the human female.

Inhibitory effects of lactation on follicular development are indicated by the substance of many of the reports cited above (Dawson; Dukes; Perry; Schwartz; Sharman; Williams, Garrigus, Norton and Nalbandov) and by much other information. As would be expected, the intra- and interspecies variations are great. Studies in progress at Iowa (Bradbury, personal communication) are revealing that some women experience an atrophy of the vaginal epithelium during the second and third month of lactation. The atrophy is indicative of a lack of ovarian estrogen and suggests that follicular development is not normal. Observations that are

similarly suggestive have been made in other species. The absence of estrogen in significant quantities during lactation in the mouse (Atkinson and Leatham, 1946) and guinea pig (Rowlands, 1956) is believed to be the reflection of a delay in the resumption of follicular growth and ovulation. Mother rats and mice may copulate and conceive within 24 hours after delivering a litter of young. While the mother is nursing the newborn litter, the fertilized eggs of the new pregnancy develop into blastocysts, but these blastocysts fail to implant in the uterus at the usual time (Talmadge, Buchanan, Krainitz, Lazo-Wasem and Zarrow, 1954; Whitten, 1955; Cochrane and Meyer, 1957). This delay in implantation is apparently due to a lack of estrogen, because an injection of estrogen will result in implantation of the blastocysts. The suppression of estrous cycles during lactation in the mouse and rat is influenced in part by the size of the litter. A litter of 8 to 10 young will inhibit cycles, whereas cycles are displayed if the litter is reduced to 2 or 3 young (Parkes, 1926a; Hain, 1935). The cottontail rabbit (*Sylvilagus floridanus*) seems to be a species in which ovarian follicular development is little if any affected by lactation, for Schwartz (1942) stated that suckling does not prevent ovulation after coitus, at least in the early stages of lactation.

### III. Corpus Luteum

The formation of the corpus luteum has been described for many species (see reviews in Corner, 1945; Harrison, 1948a; Brambell, 1956). In general, after rupture of the follicle and discharge of the ovum, the granulosa is invaded by blood vessels from the theca interna (Bassett, 1943). They form a rich network among the enlarging granulosa lutein cells. The extent and nature of the contribution from the theca interna varies from species to species, but, as Corner states, the origin of the major part of the epithelioid cells of the corpus luteum from the granulosa may now be considered a fact.

Whereas there may be a fairly uniform pattern of development and control of ovarian follicles in mammalian forms, there are diverse mechanisms for the formation and maintenance of corpora lutea; consequently

specific examples must be presented in order to avoid the dangers of generalization.

In the rabbit copulation triggers a neurohumoral mechanism which releases gonadotrophin from the pituitary which subsequently induces ovulation in 10 to 12 hours. The ruptured follicles form corpora lutea which have a functional span of about 28 days if pregnancy ensues but only 14 days if the mating is infertile. Crystals of estrogen implanted into a corpus luteum of a rabbit will cause its persistence while other corpora lutea regress (Hammond and Robson, 1951). This suggests that either estrogen makes the corpus luteum more sensitive to pituitary maintenance (Hammond, 1956) or estrogen protects the corpus luteum from luteolytic action. In the cat, copulation induces ovulation about 25 hours after mating; the corpora lutea function for 36 days after an infertile mating, but gestation lasts 62 to 64 days. The ferret ovulates about 30 hours after copulation and the corpora lutea are functional for 42 days, whether the mating is fertile or infertile (Brambell, 1956).

In the unmated rat and mouse ovulation is spontaneous, but the resulting corpora lutea are nonfunctional and begin to regress within 2 days. After copulation the corpora lutea persist for 18 days if impregnation has occurred, but for only 12 days after an infertile mating. Copulation probably results in the release of enough additional gonadotrophin (LH or LTH) to activate the corpora lutea. In rats and mice the pituitary hormone, prolactin, is luteotrophic (LTH) (Deselin, 1949; Everett, 1956). These species have functional corpora lutea throughout lactation—actually two sets, that of pregnancy and that of the postpartum ovulation. Using the rat and taking weight and levels of ovarian enzymes as measures of activity, these corpora lutea were studied by Meyer and McShan and their associates and the results summarized in a review (Meyer and McShan, 1950). They found that the weight of the corpora lutea of pregnancy increased greatly during the latter half and that the amount of enzymes per corpus luteum was also greater. With some caution, they concluded that these corpora lutea are more highly functional during this phase of pregnancy than during the first half.

Not only copulation, but also injection of

estrogen at estrus is followed by the formation of functional corpora lutea. The estrogen maintenance of corpora lutea in rabbits and mice is offset by hypophysectomy (Höhn and Robson, 1949); presumably, therefore, maintenance is mediated through the anterior pituitary. Reece and Turner (1937) showed that estrogen stimulates the rat pituitary to produce prolactin so the latter may be the luteotrophic agent in this species. Moore and Nalbandov (1955) found that prolactin is luteotrophic in sheep. To date this is the only species other than the rat and mouse in which prolactin has been shown to have luteotrophic activity.

In the guinea pig, monkey, man, and many other species, ovulation and the formation of functional corpora lutea are spontaneous. Copulation is not known to have any neurohumoral influence in these species. The corpora lutea of the human female function for 2 to 3 months in pregnancy and for only 12 to 14 days in an infertile cycle. Bergman (1949) states that the duration of the luteal phase is limited to a maximum of 16 days. In the rhesus monkey the functional life has been estimated to be about 13.5 days in the normal cycle, and approximately 30 days when pregnancy intervenes (Hisaw, 1944). In the bitch, ovulation is spontaneous and the corpora lutea remain functional for 6 weeks irrespective of mating or pregnancy. In the lactating African elephant the corpora lutea degenerate soon after parturition (Perry, 1953); in the lactating domestic cat they not only persist, but they become "rejuvenated" (Dawson, 1946).

As a general statement, it can be said that the functional span of the corpora lutea is either adequate to permit implantation or it is prolonged by copulation (as in rats and mice) so that implantation can occur. But inasmuch as implantation occurs in many species, including man, about the sixth day after ovulation and fertilization, the margin of safety is not great and a delay in the secretion of chorionic gonadotrophin by the trophoblast must reduce the chances of a successful pregnancy.

In some species, *e.g.*, rats, mice, rabbits, an infertile mating prolongs the life of the corpora lutea. This prolonged interval of functional luteal activity is known as pseudopregnancy. As Everett has noted in his



chapter, in pseudopregnancy the hormonal aspects of pregnancy are duplicated, but no fetal tissues are present. In the pseudopregnant bitch, for example, the hormonal aspects of pregnancy are so nearly duplicated that lactation begins at the time a normal gestation would have terminated.

The duration of pseudopregnancy in different species offers evidence of adaptive or evolutionary mechanisms to control the duration of corpus luteum function, mechanisms that must be endogenous to the uterus. Rats and mice have a pseudopregnancy of 12 days duration after a sterile mating, cervical stimulation, or injection of estrogen at estrus. There is no comparable condition in guinea pigs, monkeys, or man. However, if rabbits, rats, or guinea pigs are hysterectomized, any subsequent corpora lutea will function for a time equivalent to the duration of gestation in each species (Chu, Lee and You, 1946; Bradbury, Brown and Gray, 1950), although Velardo, Olsen, Hisaw and Dawson (1953) stated that, in the rat, hysterectomy has no effect on the length of pseudopregnancy. Hysterectomy in the cow and sow will prolong the life of the corpus luteum (Melampy, personal communication). Experimental distention of the uterus by beads has resulted in alteration of the length of the estrous cycle in ewes (Nalbandov, Moore and Norton, 1955). The only explanation which seems to account for these results is that there is a luteolytic agent in the uterus (probably in the endometrium) of some polyestrous species which shortens the life of the corpora lutea in non-pregnant animals. In pregnancy, or when massive deciduomas are present, if Velardo, Olsen, Hisaw and Dawson are correct, the conversion of endometrium to decidual tissue may cause it to lose its luteolytic ability. In future studies on the duration of the functional span of corpora lutea, the possibility of luteotrophic and luteolytic mechanisms should be considered. On the other hand, a fresh start may be advisable. Few problems in reproductive and clinical endocrinology (Marx, 1935) seem to have been as resistant to clarification.

In unmated females of species not having a spontaneous "pseudopregnancy," the corpus luteum involutes shortly after its formation. The rat, in which 4 to 8 corpora lutea

are formed in each ovary at intervals of 4 to 5 days, has recognizable involuting corpora lutea from the two preceding cycles, but no remnants of older ones. The early stages of involution of the corpus luteum have been described (Brewer, 1942; Boling, 1942; Dawson, 1946; Duke, 1949; Moss, Wrenn and Sykes, 1954; Corner, Jr., 1956; Rowlands, 1956; Dickie, Atkinson and Fekete, 1957). The timetables of cellular changes given by Brewer and by Corner, Jr. are of interest for the comparison they permit with physiologic estimates of the duration of secretory activity by the human corpus luteum. On day 7 the corpus luteum seems to have reached its peak of activity, as judged by the vacuolation of its cells in Bouin's or Zenker's fluid-fixed and hematoxylin and eosin-stained preparations. Corpora lutea of days 9 to 12 show evidence of progressive secretory exhaustion.

The later stages of corpora lutea degeneration have not received the same careful attention. In women the corpus luteum undergoes a slow hyaline degeneration and the corpora albicantia persist as old scars for months or years. They may be present in ovaries 15 to 20 years after the menopause. Whether the final stage of degeneration is a process of lysis, phagocytosis, or transformation into connective tissue has not been studied.

#### IV. Follicular Atresia

It was long ago estimated that the infantile human ovary contains about 400,000 oocytes (Fig. 7.4). In the 30 years of reproductive life about 400 ova may mature and ovulate. On this basis about 1 oocyte in 1000 achieves ovulation; the other 999 are lost through a degenerative process known as atresia. The problem is not different in any other species. Whether it is monotocous or polytocous, there is always an enormous wastage of oocytes in each cycle of folliculogenesis. Atresia may have its onset at any stage of follicular growth or maturation and oocytes may degenerate before they have acquired a distinct membrana granulosa (Mandl and Zuckerman, 1950; de Wit, 1953; Payne, Hellbaum and Owens, 1956; Williams, 1956). In advanced stages of follicular development the granulosa cells may show pyknotic changes before any degenera-

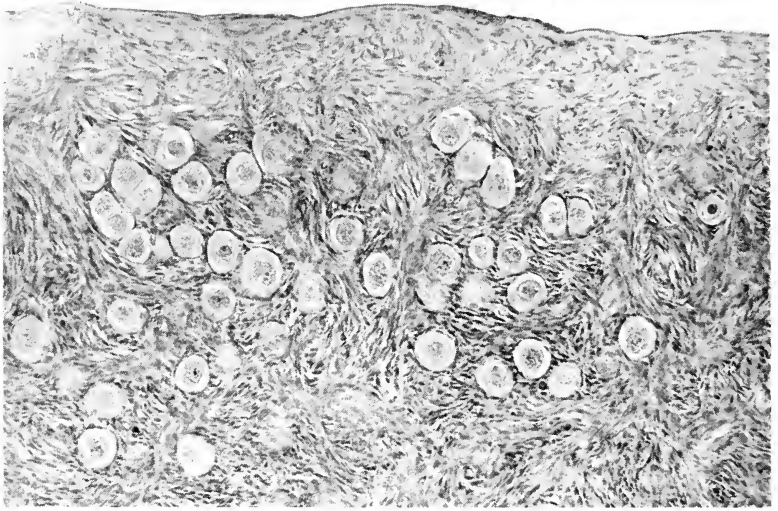

FIG. 7.4. Ovary from 28-month-old child. Many primordial follicles just beneath the tunica albuginea. (Courtesy of Dr. J. T. Bradbury.)



FIG. 7.5. Immature rat hypophysectomized 7 days previously. Some follicles persist and grow to medium size. Many become atretic and leave rings of pyknotic thecal or interstitial tissue. (Courtesy of Dr. R. M. Melampy.)



FIG. 7.6. Intact immature rat given progesterone for 3 days. The various-sized follicles in this area are in early stages of atresia. The pycnotic granulosa cells are dispersing into the follicular fluid and the oocyte in the small follicle at the upper left is denuded. (Courtesy of Dr. J. T. Bradbury.)

tive changes are evident in the oocyte. When vesicular follicles become atretic the granulosa disintegrates and the cells disperse into the liquor folliculi (Knigge and Leatham, 1956). If the follicle has developed a distinct theca interna, the theca regresses after the granulosa has disintegrated. In rats the atretic follicles leave no recognizable histologic remnants. In some species the theca regresses back to ovarian interstitial tissue (Dawson and McCabe, 1951; Williams, 1956). In the ovary of the human female and rhesus monkey the atretic follicle leaves a scar (corpus atreticum) in which the membrana propria persists for months as a folded hyaline membrane within the loose fibrous remnant of the theca.

The cause of follicular atresia is not known. Immediately after hypophysectomy there is a wave of atresia in the ovary of the immature rat (Fig. 7.5) and rabbit (Foster, Foster and Hisaw, 1937). In adult rats the postovulatory wave of follicular atresia has

been attributed to an action of the corpora lutea (Atkinson and Leatham, 1946). Injections of androgen or of progesterone increase the incidence of atresia in rat ovaries (Fig. 7.6) (Paei, 1949b; Barraclough, 1955; Payne, Hellbaum and Owens, 1956). Further study is necessary to determine whether the atresia is due to a direct effect of androgen or progesterone on the follicles, or whether the postovulatory decline in gonadotrophins, like hypophysectomy, withdraws a supporting influence and permits the follicles to degenerate. The supporting influence may be estrogenic because injections of estrogen at the time of hypophysectomy will prevent, or at least delay, the expected follicular atresia (Fig. 7.7). Some months after hypophysectomy the number of remaining oocytes is greater than in the ovaries of normal litter-mate sisters (Ingram, 1953). This suggests that vegetating oocytes are less liable to undergo

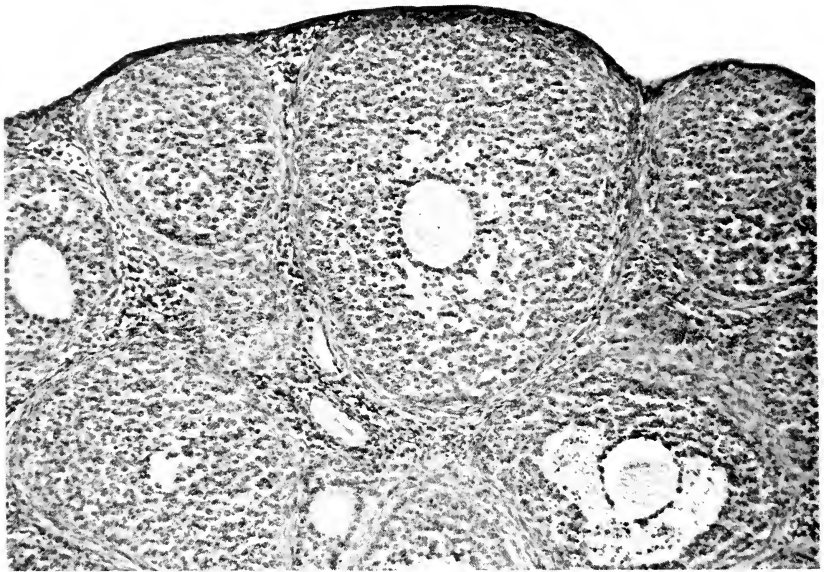

FIG. 7.7. Immature hypophysectomized rat treated with estrogen (diethylstilbestrol). Many follicles have developed to a size appropriate for antrum formation. The interstitium is atrophic but the theca is differentiated. One follicle is obviously atretic. (Courtesy of Dr. J. T. Bradbury.)

atresia than those which have entered the growth phase.

Hisaw (1947) discussed the problem and marshaled a number of facts in support of the idea that atresia is due to a defective differentiation of the theca interna, with a resulting deficiency of estrogen which is considered necessary for growth and differentiation of the granulosa. Ultimately the pituitary is involved because the success which has been achieved in the production of superovulation reveals that the number of follicles maturing and ovulating is a measure of the amount of gonadotrophic hormone. But it is equally true that there is an optimal dosage and time beyond which defects appear in the form of cystic follicles and premature luteinization (see review by Hisaw and more recently Zarrow, Caldwell, Hafez and Pincus, 1958).

The disintegration of the discus progerus of the mature follicle and the dissolution of the granulosa in an atretic follicle have led several investigators to suggest that the

stimulus to ovulation and/or atresia is identical (Harman and Kirgis, 1938; Dawson and McCabe, 1951; Moricard and Gothié, 1953; Williams, 1956). Moricard and Gothié found that intrafollicular injection of HCG or PMS caused first polar body formation within 4 hours. Control injections of estrogen or serum were ineffective. Dempsey (1939) noted that maturation spindles were present in nearly all the oocytes in medium and large follicles which had undergone atresia shortly after ovulation had been induced by luteinizing hormone. Inasmuch as the tubal egg may give off the second polar body about the time the corona radiata is lost, it is interesting to speculate on the significance of the fact that the eggs in atretic follicles may also give off polar bodies just as they are denuded of granulosa (Fig. 7.8).

#### V. Hormones of the Ovary

The hormones of the ovary are the estrogens, progesterone, androgen, and relaxin. The first three are the ovarian steroid hor-

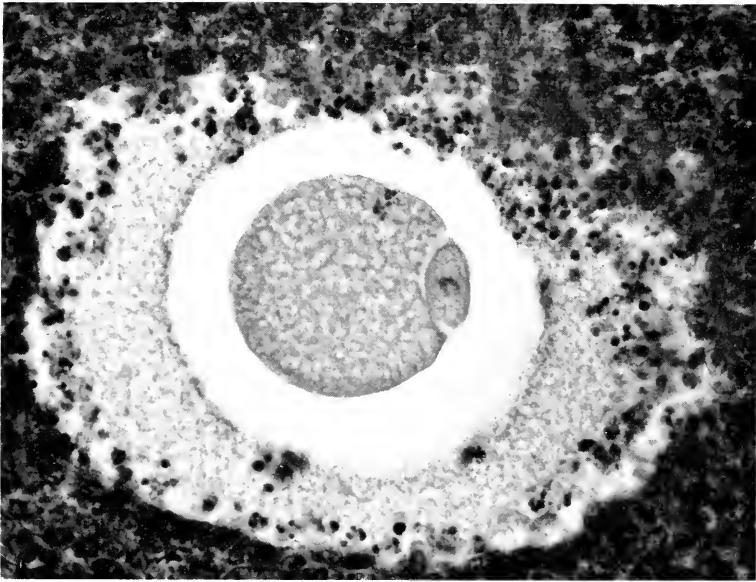

Fig. 7.8. Atretic follicle in immature rat given progesterone for 3 days. First polar body and second metaphase spindle. (Courtesy of Dr. J. T. Bradbury.)

mones and are among the most important hormones participating in the regulation of reproductive physiology. In the present book, as in editions 1 and 2, the discussions of their many actions constitute one of the central themes.

Relaxin is a protein rather than a steroid hormone and has always been considered more or less apart from the latter. The steps in proving its existence were reviewed by Hisaw and Zarrow in 1950, and the present status of the subject is discussed in the chapter by Zarrow. Unlike the other ovarian hormones, its clinical value is still uncertain (Swann and Schumacher, 1958; Stone, 1959).

Ovarian androgens present a perplexing problem. Evidence for their production is abundant (Guyenot and Naville-Trollet, 1936; Hill, 1937a, b; Deamesly, 1938a; Bradbury and Gaensbauer, 1939; Greene and Burrill, 1939; Chamorro, 1943; Price, 1944; Katsh, 1950; Desclin, 1955; Johnson, 1958), but the extent to which they are produced by the ovaries of normal females, and the nature of their action in normal females are

uncertain (Parkes, 1950). It has been postulated that they are produced during the normal cycle in the rat. Payne, Hellbaum and Owens (1956) suggested that the interstitial androgens produced at estrus are responsible for the postovulatory atresia of the partially developed follicles. The production of ovarian androgens has been demonstrated most effectively under abnormal conditions of stimulation. The newborn rat ovary will produce androgens when stimulated by human chorionic gonadotrophin (Bradbury and Gaensbauer, 1939). The treated infant rat shows a marked enlargement of the clitoris and may even develop the cartilage anlage of the os penis. Female guinea pigs are masculinized by injections of HCG (Guyenot and Naville-Trollet, 1936). Ovaries transplanted to the ear of the castrate male mouse will produce enough androgen to maintain the prostate and seminal vesicle (Hill, 1937a, b). Ovarian transplants into the seminal vesicle may exhibit a localized androgenic stimulation of that tissue (Katsh, 1950). Ovaries of a rat in

parabiosis with a castrate partner become hypertrophied and produce enough androgen to stimulate prostatic tissue (Johnson, 1958); associated with the condition is an unusual thecal and interstitial tissue hypertrophy. The masculinizing features of the Stein-Leventhal syndrome (polycystic ovary) have been attributed to the presence of androgens, having their source perhaps in the hilar cells of the ovaries (Lisser and Traut, 1954), but the action of other steroids with masculinizing properties also has been suggested (Fischer and Riley, 1952). The latter possibility might well be checked in any case when the production of androgens by the ovary is suspected.

Estrogen and progesterone are the ovarian hormones whose action in the female has been studied the most extensively. The steps which led to their extraction and chemical identification were described by Doisy and by Willard Allen in the 1932 and 1939 editions and will not be repeated here. Attention, however, will be directed to the isolation and identification of several naturally occurring gestagens in addition to progesterone (Davis and Plotz, 1957; Zander, Forbes, von Münstermann and Neher, 1958). These are metabolic degradation products which still retain progestational activity.

Now as in the period 1932 to 1939, there are many unsolved problems, but it is equally true that much of interest and value has been learned. Not the least of these contributions has been the clarification of the pathways of their biosynthesis (see chapter by Vilee). In the sections which follow particular attention will be given to the problem of their origin, to the rate of production, the manner of transport and storage, and to their "half-life."

#### A. CELLULAR ORIGIN

As Vilee points out in his chapter, estrogen and progesterone are apparently derived from cholesterol by a series of chemical changes. Within the ovary and in the corpora lutea of rats, there is a definite reduction in the concentration of ascorbic acid and cholesterol after gonadotrophin administration. These changes have been considered evidence for the activation of hormone synthesis (Everett, 1947; Miller and Everett, 1948; Levin and Jailer, 1948; Aldman,

Claesson, Hillarp and Odeblad, 1949; Claesson, Hillarp, Högberg and Hökfelt, 1949; Noah and van Rees, 1958).

Efforts to identify the cell types in which these processes take place have not been altogether successful. We have noted, for example, that several tissues such as testis, placenta, and occasionally the adrenal cortex can produce estrogen. These are tissues, then, which produce more than one hormone. Gardner emphasized this during a discussion of Parkes' (1950) review of androgenic activity of the ovary, when he called attention to Dr. Furth's observations that some ovarian tumors possess potentialities for bisexual hormone production. About the same time, Shippel (1950) postulated that thecal cells may be a source of estrogen and androgen and that the type of hormone produced may depend on particular stresses or stimuli. On the other hand, many investigators, and particularly those interested in the application of histochemical procedures,<sup>3</sup> have proceeded under the assumption that there are tissues of the ovary in which one hormone is produced predominantly. They found, for example, that the reactions of follicular granulosa and theca cells are strikingly different (Dempsey and Bassett, 1943; Dempsey, 1948; Shippel, 1950). To be sure, the results which have been obtained have not led to agreement with respect to details, but there is much evidence from the reactions which have been described, as well as from the older morphologic studies, that theca interna, interstitial, and luteal cells and, perhaps to a lesser extent, granulosa cells, are active in steroid hormone synthesis. What is less certain than the fact that these cells, and consequently the ovaries, produce estrogen, progesterone, and androgen is their relative role compared with that of other tissues. Presumably it is major; nevertheless, evidence for the extra-ovarian origin of estrogenic substances is provided by the occurrence of cyclic vaginal activity in ovariectomized animals (Kostitch and Těčbakovitch, 1929; Mandl, 1951; Veziris,

<sup>3</sup>Dempsey and Bassett, 1943; Dempsey, 1948; Claesson and Hillarp, 1947a-c; Claesson, Diezfabus, Hillarp and Högberg, 1948; McKay and Robinson, 1947; Shippel, 1950; Barker, 1951; Rockenschaub, 1951; White, Hertig, Rock and Adams, 1951; Deane, 1952; Furuhielm, 1954; Nishizuka, 1954.

1951) and by the high titer of estrogens in the urine from ovariectomized rats on a high fat diet (Ferret, 1950).

Comer, as long ago as 1938, in a consideration of the subject, emphasized that there is only circumstantial evidence that the ovary is the major site of estrogen production. Attempts to extract estradiol or any other estrogen from ovarian tissue had yielded very small amounts. MacCorquodale, Thayer and Doisy (1936) processed 4 tons of hog ovaries and recovered about 6 mg. estradiol from each ton. They estimated that the concentration in liquor folliculi was of the order of 1 part in 15,000,000 and that about 0.1 of this concentration is in the rest of the ovarian tissue. There are much better sources from which "ovarian hormone" can be extracted than from the ovary, *i.e.*, placenta, pregnancy urine, the urine of the stallion or boar. The adrenal is also a source and there may be other tissues as well, for Bulbrook and Greenwood (1957) reported that urinary estrogen continued to be excreted after oophorectomy and adrenalectomy of a breast-cancer patient.

Whatever the relationships are quantitatively between the follicles and the other estrogen-secreting tissues, the evidence that the follicles are a major source of estrogenic substances remains impressive. This is also true of the corpus luteum. The human corpus luteum produces as much, or more, estrogen than was produced during the follicular phase. In the rat and mouse, estrogen production during the luteal phase must be low because more than 1 part of estrogen nullifies the action of 1000 parts of progesterone in these species (Velardo and Hisaw, 1951). By contrast, ratios as high as 100 parts of estrogen to 1000 parts of progesterone enhance the progestational reactions in women (Long and Bradbury, 1951).

The different tissues of the ovary—membrana granulosa, theca interna, and interstitial cells—have been studied in efforts to ascertain whether they are sites of the production of specific hormones. Inasmuch as unruptured follicles and corpora lutea secrete both hormones, the two structures must be considered. It has long been known that corpora lutea secrete estrogen as well as progesterone. Evidence supporting the conclusion that progesterone is secreted by

the preovulatory follicle is more recent, but it comes from many sources. The possibility was first suggested following the discoveries that the beginning of mating behavior (Dempsey, Hertz and Young, 1936) and the decrease in tissue uterine fluid (Astwood, 1939), which depend on the presence of small amounts of progesterone, coincide with the beginning of the preovulatory swelling. More recently, progesterone has been found in the follicular fluid from sows, cows, and the human female, and, in small quantities in blood plasma of the rabbit, human female, and rhesus monkey during the follicular phase of the cycle (Duyvené de Wit, 1942; Forbes, 1950, 1953; Bryans, 1951; Kaufmann, 1952; Edgar, 1953b; Buehholz, Dibbelt and Schild, 1954; Zander, 1954).

Earlier in this section it was noted that there is much evidence from both histochemical and the older morphologic studies that theca interna, interstitial tissue, and luteal cells, and to a lesser extent, granulosa cells secrete the ovarian steroid hormones. Many who have used histochemical methods still feel that, even though these methods demonstrate steroids and their precursors, the reactions are not sufficiently specific for identification of the individual hormones. Others, however, have been more confident, and when the evidence they have presented is combined with that reported in some of the more conventional morphologic studies the following summarization of opinion seems justified. Granulosa cells of the follicles and granulosa lutein cells of the corpora lutea contain progesterone or a precursor and secrete this hormone (Nishizuka, 1954; Green, 1955). Cells of the theca interna, theca lutein cells, and interstitial cells are believed to secrete estrogen and possibly androgen (Comer, 1938; Deanesly, 1938a; Pfeiffer and Hooker, 1942; Hernandez, 1943; Claesson and Hillarp, 1947a, b; Rockenschaul, 1951; Aron and Aron, 1952; Furuholm, 1954; Nishizuka, 1954; Fetzer, Hillebrecht, Muschke and Tonutti, 1955; Johnson, 1958). The interstitial cells have been the object of much study and will be given especial attention.

Interstitial tissue or cells in the ovary is not as clear a concept as it is in the testes. In the latter interstitial or Leydig cells are derivatives of connective tissue elements

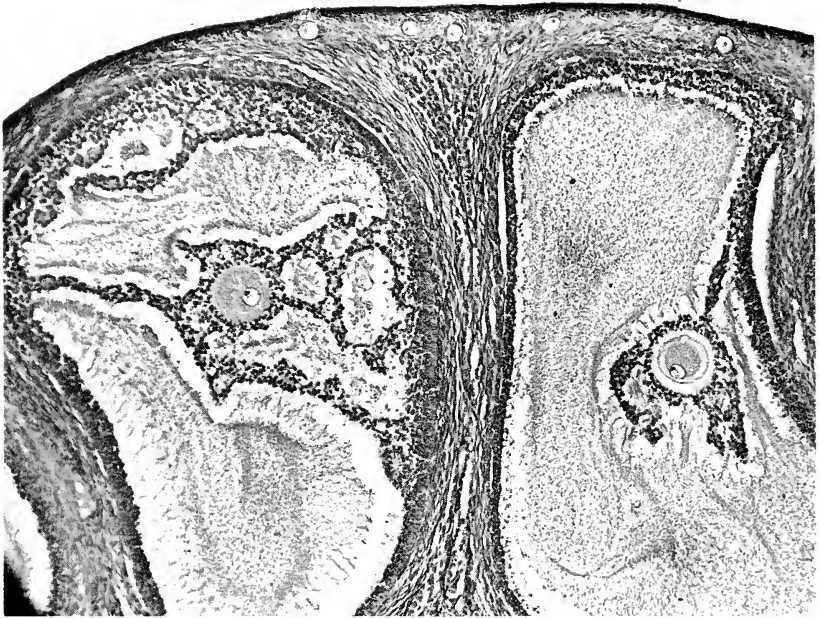

FIG. 7.9. Anestrus rabbit. Large follicles undergoing atresia. Interstitium is visible only as the narrow wedge of granular tissue extending from the cortex into the intrafollicular septum. (Courtesy of Dr. J. T. Bradbury.)

and can dedifferentiate to form connective tissue cells (Esaki, 1928; Williams, 1950). The role of Leydig cells as secretors of testicular androgen or a precursor is not questioned. In the ovary it is also presumed that undifferentiated connective tissue elements exist, indeed much of the stroma must be composed of such cells. It is believed rather generally, although unequivocal proof has not been given, that the theca interna is derived from connective tissue elements and that, as a component of the Graafian follicle, it secretes estrogen and possibly androgen (*loc. cit.*). After ovulation and corpus luteum formation, and after atresia in the case of follicles not rupturing, the cells of the theca interna may perhaps resume their place as connective tissue cells or they may become interstitial cells (Mossman, 1937; Dawson and McCabe, 1955; Rennels, 1951; Nishizuka, 1954; Williams, 1956). The prominence of interstitial tissue varies from species to species and also with stages of the

reproductive cycle. Whether it is functional in producing hormones has been controversial, but most contemporary investigators seem to feel that internal secretory capacity has been demonstrated. In all the work that has been done, supporting evidence is varied; in some cases it is circumstantial, but in others it is quite substantial.

Interstitial tissue is deficient in the anestrus rabbit, and even though there may be considerable follicular development, there seems to be little or no estrogen production (Claesson and Hillarp, 1947a) (Fig. 7.9).<sup>4</sup> The hypertrophied interstitium of the estrus rabbit (Fig. 7.10) undergoes further development during pregnancy and seems almost as luteinized as the corpora lutea

<sup>4</sup>Regressive changes in the reproductive tract and accessory structures following ovariectomy of the anestrus opossum were taken to indicate that these parts receive estrogenic stimulation of ovarian origin during the anestrus (Morgan, 1946; Risman, 1946).



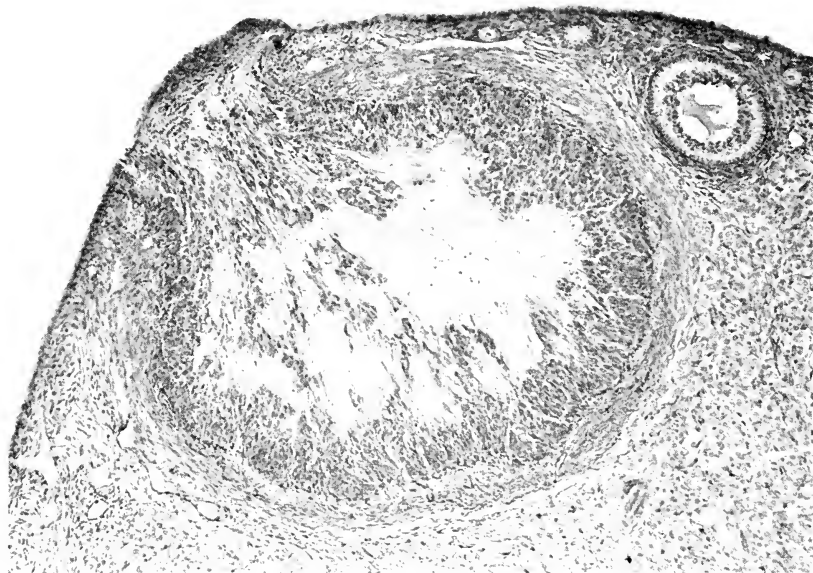

FIG. 7.10. Postovulatory estrous rabbit. The streaming of the follicular contents into the stigma is evident. Note the epithelioid nature of the hypertrophied interstitium. (Courtesy of Dr. J. T. Bradbury.)

(Fig. 7.11). Grossly the ovary in the anestrus rabbit is translucent whereas the estrous ovaries and the ovaries during pregnancy have a chalky white opacity due to the development of the interstitium. After hypophysectomy the interstitial cells of the rat ovary exhibit a deficiency condition and the nuclear appearance has suggested the name "wheel cells." If pituitary ICSH is administered, the deficiency cells are restored to normal (Fig. 7.12). Hyperplastic ovarian interstitium in older women has been considered a probable source of estrogen in some cases and of androgen in others.

The stimulation of interstitium by injected gonadotrophins may be associated with the formation of estrogens and/or androgens (Bradbury and Gacsbauer, 1939; Marx and Bradbury, 1940). Some rats displayed a permanent estrus; others, during a period of androgenic function, were masculinized. During this period, the theca and interstitium were not luteinized in many cases and it was concluded from the responses of accessory organs that these small

immature cells had secreted male hormone and perhaps female hormone, too. In rats with fully luteinized theca and interstitium and the pronounced estrous symptoms, it was considered that the androgenic effect was no longer apparent. Information obtained recently, however, suggests that the permanent estrus, when it was shown, may have been a consequence of an androgenic effect. Cystic follicles which might have stimulated a permanent estrus had a vagina been present, were found in many adult guinea pigs which had received androgen prenatally (Tedford and Young, 1960).

Without necessarily excluding the possibility that the heterotypical hormone is also produced, many articles contain suggestions that interstitial tissue has specific estrogenic or androgenic activity. There is the report that an ovarian interstitial-cell tumor was producing estrogens (Plate, 1957). The observation that estrogen continues to be secreted by ovaries in which the follicles had been destroyed by x-rays was reported by Parkes (1926b, 1927a, b), Brambell, and

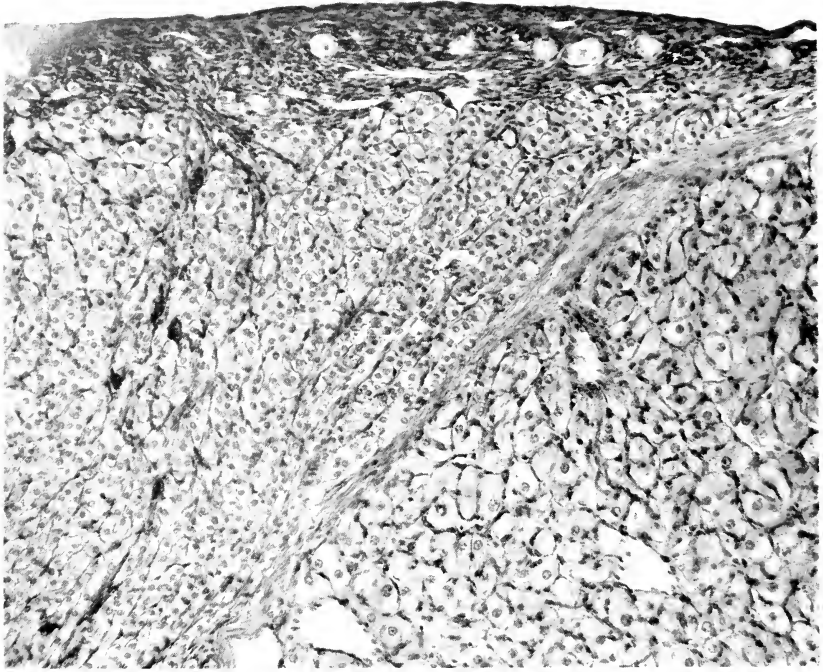

FIG. 7.11. Ovary from pregnant rabbit. Large luteinized cells in functioning corpus luteum. Hypertrophied interstitium. Primordial follicles in cortex. (Courtesy of Dr. J. T. Bradbury.)

Parkes (1927), Genter (1931), Schmidt (1936), Mandl and Zuckerman (1956a, b), and others. This conclusion would seem to be strengthened by the recent report that there is no intensification of the secretion of gonadotrophins by x-rayed rats in which there was an apparent destruction of the ova and follicles (Westman, 1958). Evidence of an entirely different sort for the secretion of estrogen by interstitial tissue has been presented by Ingram (1957). Autografts of medullary tissue containing interstitial tissue but no follicles were made in rabbits. Five animals from which this tissue was recovered had uteri which were not as atrophic as the uteri of spayed animals. He noted, however, that in the absence of the follicular apparatus the capacity to secrete estrogen is soon lost. As we have seen,<sup>2</sup> Ingram is one of several investigators who have related the functioning of interstitial tissue to granulosa elements.

Histochemical staining procedures for cholesterol indicated to Dempsey (1948) that the theca interna is a possible source of estrogen. The results obtained during a more extensive utilization of histochemical reactions in studies of the ovaries of nonpregnant, pseudopregnant, and pregnant rabbits, and in the ovaries of rats and guinea pigs were consistent with the conclusion that a lipid precursor of estrogenic substances is present in interstitial tissue (Claesson, 1954; Claesson and Hillarp, 1947a, b; Claesson, Diezfelusy, Hillarp and Högberg, 1948).

Rennels (1951), on the basis of histochemical reactions in the ovaries of immature rats, advanced the hypothesis that interstitial tissue has a dual origin. There is a primary type present between 10 and 18 days after birth which is closely associated with granulosa outgrowths and ingrowing cords of cells from the germinal epithelium. A secondary type is formed later from the

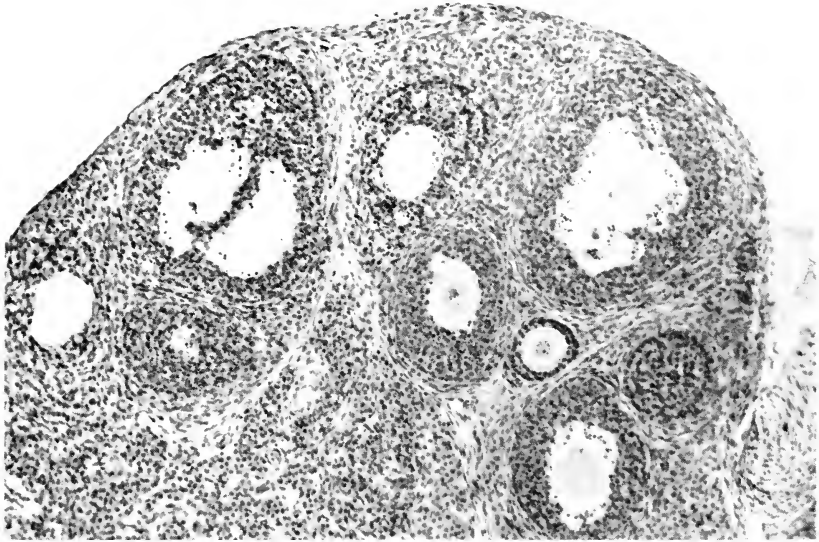

FIG. 7.12. Immature hypophysectomized rat after 3 days treatment with Armour's ICSH. The interstitium is restored and is mildly hyperplastic. Nearly all of the vesicular follicles are atretic. The theca blends into the interstitium. Two of the oocytes contain maturation spindles. (Courtesy of Dr. R. M. Melampy.)

theca interna of atretic follicles. He presented no evidence for the production of estrogen by the latter tissue, but expressed the opinion that Claesson and Hillarp (1947b) had done so. Under the assumption that estrogen rather than androgen is produced by ovaries of untreated rats during the early juvenile period (10th to 18th day), he interpreted the presence of histochemically reactive materials in the primary interstitial tissue as an indicator of estrogenic activity. To Huseby, Samuels and Helmreich (1954), the steroid- $3\beta$ -ol dehydrogenase activity in interstitial cell tumors having androgenic activity, suggested a relationship between the presence of this enzyme and the production of the androgen.

#### B. AMOUNTS OF HORMONE PRODUCED

Dependable estimates of the rate of estrogen and progesterone production would provide investigators of reproductive physiology with interesting and valuable information. It must be recognized, however, that there are many pitfalls and outright difficul-

ties; consequently the estimates which have been made must be regarded as tentative. Furthermore, they are of limited value. The amounts produced probably deviate greatly from the quantities which are *effective* in meeting the threshold requirements of the tissues the ovarian hormones stimulate. This latter information would make the greater contribution to an understanding of the functioning of these substances in the regulation of reproductive processes. Most efforts to estimate the rate of secretion of estrogen have involved measurements of the amount of hormone given subcutaneously that will restore normal structure or function in ovariectomized animals. As Corner (1940) emphasized, estimates obtained in this manner are based on the assumption that a hormone injected once daily in an oil solution is utilized by the body as efficiently as a hormone produced by an animal's own ovaries. Gillman (1942), Barahona, Bruzzone and Lipschutz (1950), and Zondek (1954) are among the many who have directed attention to the fact that the amount of an ex-

gen required to evoke one response often is different from that required for a second response. For example, the amount of estradiol necessary to produce perineal enlargement in the baboon is less than that required to produce withdrawal bleeding. In the human female, the order of sensitivity of three tissues to estrogen is uterine cervix, vaginal mucosa, endometrium (Zondek, 1954). Theoretically, therefore, if the response of tissues is to be used in estimating the amount of hormone produced, the investigator should follow the response having the highest threshold value. Gillman also called attention to another complication. The minimal amount of estrogen necessary to produce a response does not necessarily approximate the amount being produced, because, in the instance he cites, larger amounts do not produce a larger perineum.

Another complicating circumstance is the occurrence of "inherent" cycles (in some cases the length of a reproductive cycle) of responsiveness which have been demonstrated in ovariectomized females receiving constant amounts of estrogen from exogenous sources. Many such animals have displayed cyclic vaginal changes (del Castillo and Calatroni, 1930; Bourne and Zuckerman, 1941a), uterine bleeding (Zuckerman, 1940-41), and running activity (Young and Fish, 1945). This unknown factor must be taken into consideration in any attempt to estimate the rate of estrogen production. Existence of this factor gives emphasis to the importance of direct determinations, when they can be made, either from follicular fluid or from freshly drawn blood. Corresponding considerations would hardly be thought of as applying to progesterone. Most, if not all, of its actions are synergistic or potentiating. Presumably, therefore, they are directly dependent, not so much on any changes in the inherent responsiveness of the tissues as on the extent to which the tissues have been conditioned or primed by the estrogen.

A part of the picture which must be brought into context with the problem of estrogen secretion comes from a review of the temporal factors in a normal cyclic animal. In animals with short estrous cycles (4 or 5 days in the rat, mouse, and hamster), and in

species in which the cycles are longer as in the guinea pig it has generally been assumed that estrogen is produced maximally at the time of estrus. This is an assumption based on the simultaneous occurrence of the cornified vaginal smear and the display of estrous behavior. When one considers that 48 to 72 hours are necessary for vaginal epithelium to proliferate and then degenerate into cornified cells, it is obvious that the estrogen which starts these changes must be elaborated 2 or 3 days before estrus and therefore before the size of the follicles is maximal. Zondek (1940) demonstrated that if an immature rat was injected with HCG the ovaries could be removed 27 hours later and the rat would exhibit vaginal cornification in 84 to 96 hours. This emphasizes that the estrogen which caused the cornified smear had been elaborated 2 or 3 days before vaginal estrus (Zondek and Sklow, 1942; Green, 1956). The dilation of the uterus with fluid late in the proestrus (Astwood, 1939) is also evidence that the effective estrogen had been elaborated 24 to 30 hours earlier.

Problems of assay are involved in any attempt to estimate secreted estrogen and are discussed briefly by Emmens (1950a, b). They are more serious in the case of the estrogens than in the case of progesterone. The bioassay of estrogens is usually based on vaginal cytology or change in uterine weight. The vaginal cytology or smear method is essentially the original method of Allen and Doisy (Kahnt and Doisy, 1928; Allen, 1932). Ovariectomized rats or mice are given subcutaneous injections of the substance being tested for estrogenic potency. Smears are made of the vaginal contents 24, 48, 60, and 72 hours later. If the smear reveals the presence of cornified cells 60 to 72 hours after the first injection, the tested substance is judged to be estrogenic. By using groups of animals at each of several dose levels, the minimal effective dose can be judged. The smallest amount of substance which will produce cornified smears in 50 to 70 per cent of the test group is usually designated as the rat or mouse unit. Intravaginal tests, introduced by Berger (1935) and by Lyons and Templeton (1936), and refined, especially by Biggers (1953) and by Biggers and Clar- ingbold (1954, 1955), are 200 times more

sensitive than those in which the estrogen is administered subcutaneously. When the mean number of arrested mitoses was used as the measure of estrogenic activity, the sensitivity was increased another ten times (Martin and Claringbold, 1958).

Immature rats or mice can also be used for the assay of estrogens. The establishment of vaginal patency and mucified or cornified vaginal smear denote estrogen effects. Vaginal patency *per se*, however, is not specific for estrogen because androgen will also induce precocious vaginal patency (Rubinstein, Abarbanel and Nader, 1938; Marx and Bradbury, 1940). Injection of estrogen into immature animals causes a rapid increase in the weight of the uterus, due to water imbibition. Astwood (1938) found that the immature rat uterus increases in weight as early as 6 hours after an injection of estrogen; however, the optimal response was at 30 hours. Just above threshold levels graded doses produce graded increases in uterine weight. This makes it possible to plot a dose-response curve so that closer approximations of potency can be achieved. Some authors have used ovariectomized animals for the uterine response method. This requires a prior operation and subsequent adhesions may make it difficult to strip out the uterus cleanly at the end of the test.

Whatever the test, each estrogen derivative or synthetic estrogen has an optimal assay interval for maximal effect depending in part on its solubility, rate of absorption, and utilization (Hisaw, 1959). For this reason a standard assay may not be an accurate indicator of the estrogenic potency of several compounds. This factor plus some competitive antagonism make this method impractical for the assay of mixtures of estrogens (Merrill, 1958). Whatever their faults, the bioassay methods in general are very sensitive and will detect estrogens in 0.1 to 1.0  $\mu\text{g}$ . quantities.

The chemical assay methods for estrogen are rather involved and have usually been reliable only in milligram quantities. Fluorometric methods were tried and generally discarded because frequently small amounts of contaminants were strongly fluorescent; consequently fluorescence was being obtained in the absence of biologic activity

(Bitman, Wrem and Sykes, 1958). Recently paper chromatographic methods have permitted sufficient purification and isolation to make identification and quantification of estrogens in microgram quantities (Brown, 1955; Smith, 1960; Svendsen, 1960).

The most common bioassay methods for progesterone are still the Corner-Allen and the Clauberg tests which utilize the rabbit. The animal is primed with estrogen and then given progesterone after an appropriate interval. A portion of the uterus is removed and examined histologically for the degree of glandular development in the endometrium. The test is relatively insensitive since it requires about 1 mg. progesterone per rabbit. McGinty, Anderson and McCullough (1939) increased the sensitivity of the test to 0.5 to 5.0  $\mu\text{g}$ . by injecting the progesterone into the lumen of an isolated segment of the rabbit uterus. The histologic response of the endometrium in this isolated segment was then judged.

Hooker and Forbes (1947) adapted the McGinty intra-uterine technique to the uterus of the ovariectomized mouse. The end result is judged histologically by the characteristics of the endometrial stromal nuclei of the isolated uterine segment. The sensitivity is of the order of 0.3  $\mu\text{g}$ . per ml. and the method has been used widely. This advantage of the Hooker-Forbes technique is that it is sensitive enough to detect gestagens in blood plasma and liquor folliculi. Disadvantages are that the test is not specific for progesterone, and that certain gestagens such as 17- $\alpha$ -hydroxyprogesterone which is devoid of progestational activity in some species (rabbit, guinea pig, man) are very active in the mouse test (Zarrow, Neher, Lazo-Wasem and Salhaniek, 1957; Short, 1960).

There are spectrophotometric techniques for progesterone assay (Reynolds and Ginsburg, 1942; Zander and Simmer, 1954; Short, 1958; Sommerville and Deshpande, 1958). These methods have the advantage of instrumental precision, but require rather tedious initial chemical purification. However, they have proved of especial value in comparative studies of the blood levels of progesterone in sheep with active and inactive ovaries, in studies of the progesta-

one content of unruptured follicles in the ovaries of cows and sows, and in determinations of the quantities of progesterone secreted by 1 or 2 corpora lutea in sheep (Edgar, 1953a, b; Edgar and Ronaldson, 1958).

After allowance was made for these considerations tentative estimates were given: rhesus monkey, 200 I.U. or 20  $\gamma$  estrone daily; human female, 3000 I.U. or 300  $\gamma$  estrone daily (Corner, 1940); baboon (*Papio porcarius*), somewhat more than 0.04 mg. estradiol benzoate daily (Gillman, 1942); guinea pig, less than the equivalent of 1.8  $\mu$ g. estradiol daily (Barahona, Bruzzone and Lipschutz, 1950). The variation in the responsiveness of individual animals was recognized by all the investigators. Two important variables were not considered, the cyclic growth of follicles, and the number of developing follicles. Presumptive evidence that the amount of secreted estrogen increases as the follicle enlarges was provided by the demonstration that more and more estrogen is required to maintain perineal turgescence (Gillman and Gilbert, 1946). The number of developing follicles may vary greatly within a species, in the guinea pig, for example, from 1 to at least 6. The fact that two corpora lutea in the ewe do not produce more progesterone than one (Edgar and Ronaldson, 1958) could prepare us for a corresponding finding with respect to estrogen.

The problem of estimating the rate of progesterone secretion is beset by many of the difficulties that confront an investigator attempting to estimate the rate of estrogen production, but one circumstance especially has facilitated progress by those especially interested in progesterone. It is that the amount of excreted free pregnanediol or excreted sodium pregnanediol glucuronidate is about 1.7 the amount of injected progesterone (Trolle, 1955a, b); from determinations of either of the former, therefore, the amount of the latter can be estimated with what is believed to be a reasonable degree of accuracy. The pioneer attempt of Corner (1937) to calculate the amount of progesterone secreted by the rabbit, sow, and human female resulted in estimates (60 mg. during the luteal phase of the cycle in the latter) which are much lower than those made more recently (Ober

and Weber, 1951, 200 mg.; Kaufmann, 1952, 200 mg.; Trolle, 1955a, b, 260 to 440 mg.). It now seems that the lower estimate made by Corner can be attributed to the uncontrolled loss of sodium pregnanediol glucuronidate during storage, owing to bacterial hydrolysis (Trolle, 1955a). The rise in the 24-hour values after ovulation, the attainment of a peak the 7th and 8th days, and the decline between then and menstruation, are shown nicely in Trolle's (1955a) study. His data provide an excellent confirmation of the estimates based on structural changes within the cell (Brewer, 1942; Corner, Jr., 1956). The amount of free pregnanediol excreted during the cycle and therefore the amount of secreted progesterone varied from woman to woman, and in the same woman there was variation from one cycle to another.

Data obtained by Duncan, Bowerman, Hearn and Melampy (1960) from their chromatographic study have provided the basis of an estimate that the following average amounts of progesterone are present in the luteal tissue from swine: 23  $\mu$ g. on day 4 of the cycle; 213  $\mu$ g. on day 8; 335  $\mu$ g. on day 12; 311  $\mu$ g. on day 16; 0  $\mu$ g. on day 18. From day 16 to day 102 of pregnancy, the amount rose from 477  $\mu$ g. on day 16 to 578  $\mu$ g. on day 48 and then decreased to a low of 120  $\mu$ g. on day 102.

Edgar and Ronaldson (1958) made direct measurements of the progesterone in blood collected from the ovarian vein in ewes. The assay method consisted of extraction of 20 ml. of blood by, and partition between, organic solvents, final separation by chromatographic partition on filter paper, and subsequent estimation of the hormone by ultraviolet absorption spectroscopy. They reported that there is great variability from animal to animal. The concentration in yearling sheep was not lower than that in older animals. Because of the hypothesis advanced by Young and Yerkes (1943) that the amount of secreted progesterone is low in adolescent chimpanzees, an extension of the Edgar and Ronaldson procedures to primates would be of interest. In this connection, Edgar and Ronaldson postulated what has been brought out as a generalization in so many studies of the steroid hormones. The absolute amount of progesterone

circulating in the fluids of the body may be less important than the minimal amount. The ewes secreting less than the minimum may be unable to maintain pregnancy, whereas those secreting more may simply have surpluses which are of little significance. The same principle may be extended to the human female (Davis, Plotz, Lupu and Ejarque, 1960).

An observation new to the reviewer could be important. When two corpora lutea were present in one ovary the concentration of progesterone was in the same range as that for the ewes with one corpus luteum (Edgar and Ronaldson, 1958). In another ewe there were 2 corpora lutea in one ovary and 1 in the other, but the concentrations in the blood from the 2 ovarian veins were almost the same.

A facet of the problem of the rate of production of ovarian estrogen and progesterone which has become apparent is that endogenously and exogenously administered estrogen (Rakoff, Cantarow, Paschkis, Hansen and Walkling, 1944; Pearlman, 1957) and progesterone (Haskins, 1950; Zander, 1954; Rappaport, Goldstein and Haskins, 1957; Davis and Plotz, 1957; Plotz and Davis, 1957; Pearlman, 1957; Cohen, 1959) disappear from the blood very quickly, in the human female and in such laboratory mammals as the dog, rabbit, and mouse. Zander, for example, injected 200 mg. of progesterone intravenously into menopausal and ovariectomized women. The concentration of this hormone in the blood was 1.44  $\mu\text{g}$ . per ml. after 3.5 minutes and 0.116  $\mu\text{g}$ . per ml. after 2 hours; 24 hours after the injection progesterone could not be found by the method he employed. The data obtained by the other investigators were similar.<sup>5</sup> Using some of these data obtained from reports in the literature and from his own studies, Pearlman (1957) divided the total amount of circulating hormone ( $M$ ) by the

endogenous production rate ( $r$ ) as a means of obtaining the turnover time ( $T$ ), *i.e.*, the time required for a complete replacement of the circulating hormone by a fresh supply from the endocrine gland. His method was not free from criticism by discussants; nevertheless, informative estimates were made. The turnover time of the various estrogens was calculated to be about 6 minutes or less, that of progesterone, about 3.3 minutes.

Not unrelated to the problem of the amounts of hormone produced is the subject of plasma (and erythrocyte) binding of the ovarian hormones. Especial attention was given the subject by Rakoff, Paschkis and Cantarow (1943) who reported that as much as 50 per cent of the total estrogen content of the serum of women is present in a combined or conjugated (bound) form, and that almost all of the estrogens of pregnancy are bound to the protein fractions of the serum. Shortly thereafter, Szego and Roberts (1946) reported that two-thirds of the total estrogen in the blood in human plasma is normally associated with protein constituents, and in a subsequent series of publications (Roberts and Szego, 1946, 1947; Szego, 1953, 1957; and others) that the liver is the site of the formation of the protein-estrogen complex or estroprotein. The nature of the complex soon became controversial and has not yet been resolved (Eik-Nes, Schellman, Lumry and Samuels, 1954; Antoniadis, McArthur, Pennell, Ingersoll, Ulfelder and Oncley, 1957; Sandberg, Slaunwhite and Antoniadis, 1957; Daughaday, 1959). In the present context, however, other considerations are more important.

Protein-binding is not confined to the estrogens and their metabolites, but other steroidal hormones, progesterone, testosterone, and corticosteroids, are also present in the blood in a bound-state. In studies of the binding relationships of serum albumin, the link to the estrogens was found to be strongest, that to the corticosteroids relatively weak, and that to progesterone and testosterone intermediate (Sandberg, Slaunwhite and Antoniadis, 1957; Slaunwhite and Sandberg, 1958; Daughaday, 1959). The relationships in the case of other components of protein mixtures have been shown to be

<sup>5</sup> To a certain extent, and possibly to a considerable extent, the rapid disappearance of progesterone from the blood is explained by its storage in the fat tissue of the body (Davis and Plotz, 1957; Davis, Plotz, Lupu and Ejarque, 1960). Following intramuscular injection of  $\text{C}^{14}$ -progesterone, and assuming an even distribution of radioactivity in the fat of the body, about 17.7 per cent, 33.7 per cent, and 19.6 per cent of the administered dose was present 12, 24, and 48 hours, respectively, after the administration of the labeled hormone.

different, but they are apparently equally specific (Daughaday, 1959; Slaunwhite and Sandberg, 1959). A considerable specificity at the binding sites may be involved (Sandberg, Slaunwhite and Antoniades, 1957). Daughaday (1959) states that separate binding sites may exist for each of the steroid hormones studied, and Szego (1957) suggested that a competition for these sites may be the basis for antagonisms which are known to exist in many steroid interactions (Courrier, 1950; Hisaw and Velardo, 1951; Roberts and Szego, 1953; Velardo, 1959; Velardo and Hisaw, 1951; Zarrow and Ncher, 1953).

The most important consideration has to do with the significance of protein binding for the steroid hormones, and, in the present chapter, the significance for estrogen and progesterone. Roberts and Szego (1946, 1947) and Szego (1957) proposed that formation of the estrogen-protein complex is necessary for the transport and activity of endogenous and exogenous estrogens. Riegel and Mueller (1954), on the other hand, found that the protein-estrogen complex they used had only a slight, if any, estrogenic activity, and Daughaday (1958, 1959) expressed the opinion that the unbound steroid hormones of the plasma are probably the biologically significant moieties. He suggested that the degree of protein binding imposes a major restraint on the passage of hydrocortisone (and presumably other steroids) through the capillary membranes, but pointed out that this view has not yet been established. He then asked, in the event that the steroid-protein complex does not function in the transport of hormones from the vascular component to the cell, is it likely that the presence of a steroid-protein complex stabilizes the physiologically significant concentration of unbound steroid very much as buffer salts stabilize the small concentration of hydrogen ion? In this way, he continued, the organism would be protected against the rapid changes in concentration which characterize an unbuffered system.

At the present stage in this controversial subject, any hypothesis with respect to the significance of the protein binding of steroid hormones must be tentative. It would seem, however, that whatever emerges will have

validity only if it is compatible with the cyclic waxing and waning of reproductive phenomena. If the unbound, rather than the bound fractions, are the active fractions, the functioning of the ovarian steroid hormones must depend on the presence of unbound fractions, in some way made available at cyclic intervals to the tissues on which these hormones act. It would seem, too, that the significance of the increased capacity for binding in pregnancy (Rakoff, Paschlis and Cantarow, 1943; Baylis, Browne, Round and Steinbeck, 1955; Daughaday, 1959; Slaunwhite and Sandberg, 1959) should be a part of the picture. Tentatively, this greater binding capacity on the part of the pregnant adult, coupled with an inability of the developing fetuses to bind androgens, might account for the failure of the adult to be affected by the presence of androgen at a time when the genital tracts and neural tissues of the female fetuses she is carrying are undergoing profound modifications (Phoenix, Goy, Gerall and Young, 1959; Diamond, 1960).

## VI. Age of the Animal and Ovarian Functioning

The position of the ovary is such—at one and the same time being dependent on the pituitary, possessing its own varying capacity to function, and having an effectiveness which is limited by the responsiveness of the tissues on which its hormones act—that no simple consideration of the relationship between the age of the animal and ovarian functioning can be given. An investigation, therefore, should be planned accordingly and we find experiments in which the amount of gonadotrophic stimulation was varied when age was constant, and experiments in which age was the variable and the amount of gonadotrophin the constant. If hypo- or hyper-responsiveness of the tissues is suspected, the point can be checked by the use of spayed animals given variable amounts of ovarian hormones. When information of these sorts is brought together, a fairly accurate account of the relationship between age of the animal and ovarian activity can be prepared.

The results from many studies have revealed that the ovaries in both immature and senescent females are potentially able



to secrete hormones, both estrogen and progesterone, in amounts which are in excess of those secreted by untreated animals. The secretion of these hormones was elevated in rats, mice, and hamsters by the implantation of whole pituitaries (Smith and Engle, 1927) or by the administration of chorionic gonadotrophin (Price and Ortiz, 1944; Ortiz, 1947; Green, 1955). The reactivation of senile ovaries was first demonstrated by Zondek and Aschheim (1927) following the insertion of hypophyseal implants, and later by numerous other investigators listed in the review of the subject by Thung, Boot and Mühlboeck (1956). In more recent experiments an enhanced secretion of estrogen and progesterone followed the injection of old hamsters with chorionic gonadotrophin (Peczenik, 1942; Ortiz, 1955).

In women fertility may be lost before the menopause (Engle, 1955). Studies in progress at Iowa (Bradbury, personal communication) show that urinary gonadotrophins may be elevated before the menopause and the last ovarian cycles are achieved in the presence of excessive amounts of pituitary gonadotrophin. As a rule the human ovary is devoid of oocytes and produces relatively little estrogen at the time of the menopause. Frequently, however, there is enough residual ovarian activity (estrogen production) to maintain the vaginal epithelium for 10 to 15 years after the menopause. These observations on women suggest that as the supply of oocytes becomes depleted, less estrogen is produced and more gonadotrophin is released to stimulate the aging ovary. This sequence is in harmony with the concepts of Dubreuil (1942) and Hisaw (1947), because with fewer areas of granulosa there would be fewer centers of organizer to bring about the differentiation of thecal tissue competent to produce estrogen.

Ovarian stromal hyperplasia has been found in association with endometrial hyperplasia after the menopause (Morris and Scully, 1958). Sherman and Woolf (1959) suggested that the postmenopausal ovary may produce abnormal sexogens which bring about an endometrial proliferation and ultimately adenocarcinoma of the endometrium. Their urinary bioassay studies

indicate that the patients were excreting ICSH-type gonadotrophin. The observation has been made at Iowa that a few postmenopausal women with endometrial carcinoma were maintaining an estrogenic vaginal epithelium when they were ovariectomized at ages varying from 65 to 70 years. Subsequently the gonadotrophin excretion increased to the quantities usually seen after the menopause. In these unusual cases the aging ovaries produce estrogen, or possibly estrogen and androgen, in quantities sufficient to suppress the usual excess production of gonadotrophins.

The responsiveness or sensitivity of the ovary to gonadotrophic stimulation is not constant throughout the life of an individual. If we may judge from the studies of Corey (1928) and Selye, Collip and Thomson (1935) on newborn and 10- to 15-day-old rats, Moore and Morgan (1943) on young opossums, and Price and Ortiz (1944) and Ortiz (1947) on rats and hamsters, the prepubertal period is characterized by very rapid and great increases in responsiveness to gonadotrophic stimulation. Species differences are great. The opossum ovaries do not respond to gonadotrophic stimulation until about 100 days of age (Moore and Morgan), whereas responsiveness was first detected in the rat ovary at 4 to 10 days (Price and Ortiz) and in the hamster ovary by the 10th day (Ortiz). Such data, coupled with the appearance of the ovaries at birth, would seem to exclude the possibility of gonadotrophic stimulation during the prenatal period, and perhaps the capacity for being stimulated as well.

Certain other species are different and present problems. There is an extensive follicular development and luteinization in the fetal ovaries of the giraffe which is the basis for the suggestion that the ovaries of this species are responsive to gonadotrophin before birth (Amoroso, 1955). Such a conclusion is predicated on the assumption either that serum gonadotrophin crosses the placental membrane or that the fetal pituitary secretes gonadotrophin. Neither hypothesis has been proved. Evidence exists that the ovaries of the horse and seal are strongly stimulated before birth (Calkins, Hart, Lyons and Catehpole, 1933; Amoroso,

Harrison, Harrison-Matthews and Rowlands, 1951; Amoroso and Rowlands, 1951), but an unusual structural condition is found in these ovaries. No vesicular follicles are present and the ovaries, which are larger than those of the adult, are composed mostly of interstitial tissue which is enclosed by a thin cortex containing short chains of germ cells and a few oocytes surrounded by a single layer of epithelial cells. Comparable information does not exist for the seal, but in the horse the development of this condition is reached during the estrogenic phase and after the gonad-stimulating hormone is no longer detectable in the blood of the pregnant adult. As a result, and quite apart from the belief that serum gonadotrophin does not cross the placenta (Amoroso and Rowlands, 1955), the massive interstitial tissue hyperplasia is thought to have been stimulated by estrogenic rather than by gonadotrophic action.

The immediate postpubertal period and middle age are periods of relative stability. The period of old age has been too little studied and is in need of attention. In old mice the ovaries are reported to become unresponsive to exogenous gonadotrophin (Green, 1957). Ortiz (1955), on the other hand, stated that although a certain degree of ovarian sensitivity is lost in old hamsters, there is a surprising degree of responsiveness present until death, not only after the animal is no longer fertile, but even in animals with ovaries almost completely atrophic.

In young animals and in old animals there are irregularities of ovarian function and irregularities in the character of the cycles which probably can be related to imbalances in the pituitary-ovarian relationship. In polytocous species, fewer follicles ovulate in young animals (Young, Dempsey, Myers and Hagquist, 1938; Ford and Young, 1953, the guinea pig; Perry, 1954, the domestic pig; Ingram, Mandl and Zuckerman, 1958, the mouse and rat), and in old animals (Perry; Ingram, Mandl and Zuckerman). These statements of fact, however, do not reveal what is presumed to be more important. In young and old animals the nature of the irregularities, particularly those of ovarian function, seem to differ. Evidence collected from rhesus monkeys (Hartman,

1932) and chimpanzees (Young and Yerkes, 1943) suggests follicular growth without ovulation and luteinization, or in the guinea pig a sluggishness of follicular growth which is followed by ovulation and the formation of functional corpora lutea (Ford and Young, 1953). In old animals there may also be abnormalities of follicular growth, but as the numerous reports are read, the impression is given that abnormalities of luteinization are more prominent (Deanesly, 1938b; Wolfe, 1943; Wolfe and Wright, 1943; Loeb, 1948; Thung, Boot and Mühlbock, 1956; Dickie, Atkinson and Fekete, 1957; Green, 1957). Additional investigation will be necessary before we can be sure that the pituitary-gonadal imbalance in young animals differs from that in old animals. On the whole, the possibility seems to have received little attention, but its importance justifies more careful study.

## VII. Other Endocrine Glands and the Ovaries

### A. THYROID

The relationship of the thyroid to the functioning of the ovaries was one of the first subjects of modern endocrinologic investigation. Notwithstanding, disappointment must be expressed that after more than 50 years of effort, little more than cautious generalization is possible. This admission is not a confession of defeat; to be sure, there is an unfortunate number of uncertainties, but we have come to know what is necessary in the way of experimental design and techniques to enable us to proceed with the confidence that a gratifying clarification can be achieved. The greatest obstacle could be, not the lack of means, but rather the failure to use the means which are abundantly at hand for more coordinated efforts than many which have characterized this field in the past.

The general belief that the thyroid is involved in reproductive function is grounded in two categories of observations. The first includes those demonstrating that ovarian hormones exert an action on the thyroid. There have been many reports that in the human female the thyroid enlarges at puberty, at menstruation, and during pregnancy (Garnier, 1921; Marine, 1935; Neu-

mann, 1937; and others). Modern counterparts are the reports of the increase during pregnancy in the concentration of serum precipitable iodine (Heinemann, Johnson and Man, 1948; Dowling, Freinkel and Ingbar, 1956a; Tanaka and Starr, 1959), in serum thyroxine (Danowski, Gow, Mateer, Everhart, Johnson and Greenman, 1950), and in the accumulation of radioiodine (Pochin, 1952). Some conflicting reports should be noted. There was said to be no consistent alteration in the concentration of serum precipitable iodine in oophorectomized women (Stoddard, Engstrom, Hovis, Servis and Watts, 1957), and Pochin (1952) found no detectable variation in  $I^{131}$  uptake during the menstrual cycle in 5 women he studied. Comparable observations have been made on laboratory mammals (Greer, 1952; Soliman and Reineke, 1954; Soliman and Badawi, 1956; Feldman, 1956a) and the baboon, *Papio ursinus* (Van Zyl, 1957), except that Brown-Grant (1956) could not agree from his findings in the rat and rabbit that the level of gonadal function exerts any striking influence on thyroid activity in the normal experimental animal.

In man (Engstrom, Markardt and Liebman, 1952; Engstrom and Markardt, 1954; Dowling, Freinkel and Ingbar, 1956b) and in laboratory mammals (chiefly the rat) (Money, Kraitz, Fager, Kirschner and Rawson, 1951; Feldman, 1956a; Feldman and Danowski, 1956) the enhancement of thyroid activity is attributed to the level of circulating estrogen, whether it be endogenous or exogenous in origin. On the other hand, many who have worked with laboratory mammals have not found evidence of augmented thyroid activity, and not infrequently decreases were reported (see Paschkis, Cantarow and Peacock, 1948; and the numerous articles cited by Farberman, 1944; and Feldman, 1956a). The conflicting results may perhaps be accounted for by the circumstance that the response of the thyroid seems to be related to the duration of the estrogen treatment and to the estrogen that was used. Decreases in thyroid activity have been reported when the estrogen treatment was prolonged (Feldman, 1956a), and Money and his associates showed clearly that estrone and some other

components increased the collection of  $I^{131}$  by the thyroid of rats whereas estradiol, estriol, and diethylstilbestrol decreased the collection. Many attempts have been made to ascertain the nature of the mechanism whereby the effective estrogenic substances exert their action on the thyroid (Noach, 1955a, b; Feldman, 1956b; Dowling, Freinkel and Ingbar, 1956a, b; Bogdanove and Horn, 1958), but they are so varied and speculative that they will not be reviewed here.

The second category of observations related to the thyroid and ovarian functioning includes those in which there is evidence of action of thyroid hormone on the ovary. Reviews of this work are contained in the articles by Peterson, Webster, Rayner and Young (1952), Hoar, Goy and Young (1957), and Parrott, Johnston and Durbin (1960) and most of their citations of work done on the relationship of the thyroid to the ovary will not be repeated here. As they point out, many investigators have reported that thyroidectomy is followed by ovarian degeneration, arrested folliculogenesis, and failure of ovulation. Irregularity of the reproductive cycles was common and much of this in the guinea pig could be attributed to retarded and sporadic follicular development (Hoar, Goy and Young, *loc cit.*). The latter investigators gave especial attention to the condition of the ovaries in their hypothyroid guinea pigs. In 10 pairs from thyroidectomized animals (oxygen consumption and heart rate were depressed) follicular development was good in the sense that the follicles appeared healthy, but a generation of corpora lutea was missing in four. This absence of corpora lutea, which is not seen in normal adult guinea pigs, was believed to be a consequence of the involution of the older generation during the longer than normal interval between ovulations. It is considered significant in terms of the functional capacity of such ovaries, that although the percentage of sterile matings was higher than in the controls, that, in the course of the two studies at Kansas, 29 of 38 matings were fertile. This experience may perhaps account for the many reports (cited in the papers from the Kansas laboratory) that thyroidectomy or treatment with antithy-

roid drugs have no, or at the most relatively little, effect on the ovary. To these, several additional reports should be mentioned. In thyroid-deficient female mice, fertility and litter frequency were affected only to the extent that the estrous cycles were prolonged (Bruce and Sloviter, 1957). In the rabbit, thyroidectomy did not interrupt or alter the periodicity of follicular development, but it did eliminate the final stages (Desaive, 1948). Parrott, Johnston and Durbin (1960) express the opinion that the long physiologic life of thyroid hormone may account for many of the contradictions in the reports of the relationship between thyroid deficiency and reproduction.

Except as it is speculative, an unexplained action of thyroidectomy or the administration of goitrogenic drugs is the augmentation of the ovarian response to gonadotrophins and to anterior pituitary implants (citations in Peterson, Webster, Rayner and Young, 1952; and see in addition Janes, 1954; Janes and Bradbury, 1952; Kar and Sur, 1953). Thyroid substances, on the other hand, were inhibitory. Of alternative hypotheses, Janes favored the suggestion that during the period of propylthiouracil treatment, provided it was short rather than long, there was an accumulation of gonadotrophin in the blood and the ovarian response varied for some unknown reason according to the concentration of this latter substance in the body fluids. To Kar and Sur (1953) direct involvement of the hypophysis could be eliminated; instead a direct role of the thyroid seemed more plausible. They postulated that the absence of thyroid hormone reduced the utilization of gonadotrophic hormones by the ovary.

The reported effects of the hyperthyroid state or of administered thyroid hormone on the ovary are equally conflicting. The ovaries are described as being atrophic or exhibiting incomplete folliculogenesis, or as being essentially normal or even hypertrophied (citations in Peterson, Webster, Rayner and Young, *loc. cit.*, Hoar, Goy and Young, *loc. cit.*). Irregular cycles are said to have occurred in the rat and mouse, but no irregularity was detected in guinea pigs given thyroxine.

A tentative explanation can be given for

the many divergent reports of the relationship between the thyroid and the ovary, divergencies which are found in the clinical literature as well as in laboratory studies. In doing so, we will recall that there is abundant evidence that the ovary is a locus of action of thyroid hormone. The action may not be directly trophic, as is that of the pituitary, but it is assumed to be supportive, possibly directly so, or possibly indirectly through regulation of the general metabolic level. Whatever its nature, there must be great interspecies and even intraspecies variation in the need of the ovary for such action. In addition, within a species there appears to be a wide range of tolerance, for Peterson, Webster, Rayner and Young (1952) found in their study, in which the thyroid state was estimated from measurements of oxygen consumption and heart rate, that reproduction occurred in females in which oxygen consumption ranged from an average of 50.0 to 93.5 cc. per 100 gr. per hr. (52.9 in the controls), and heart rate from 238 to 316 beats per minute (272 in the controls). In females that failed to reproduce, the lowest values were lower than in the animals which did reproduce; nevertheless, there was much overlapping, for in this group oxygen consumption ranged from an average of 46.7 to 94.1 cc. per 100 gr. per hr., and heart rate from 202 to 330 beats per minute. Within such a framework, there are bound to be more divergent results than when normal functioning depends on more narrowly circumscribed conditions, and the failure to replicate a result does not have the same significance. As a part of the investigation of such a problem, more and better correlated information is required, and this could be the most pressing need in the field of ovarian (and reproductive) functioning and the thyroid.

#### B. ADRENAL CORTEX

The adrenal cortex elaborates its steroid hormones in a biosynthetic sequence very similar to that in the ovary. In fact, progesterone is an intermediate substance in the synthesis of glucocorticoids. Estrogen has been found in extracts of adrenal cortical tissue, but whether it represents a degradation product within the adrenal or an artifact resulting from the chemical pro-

cedures is not clear. Occasionally adrenal tumors produce physiologically significant amounts of estrogen, but normally the adrenal production of estrogen, if any, is not of physiologic significance. The atrophy of the female genital tract after bilateral ovariectomy suggests strongly that this is so.

The major hormone of the adrenal cortex, hydrocortisone or corticosterone, depending on the species, has a profound effect on protein and carbohydrate metabolism. An overproduction, as manifested by Cushing's disease, results in a wasting of body protein and other metabolic disturbances which by nonspecific influences tend to reduce gonadal function. Similarly a loss of adrenal function (Addison's disease) leads to anemia, electrolyte imbalance, and hypoglycemia. There is usually a decrease in ovarian function but some Addisonian patients have conceived and carried their pregnancies with only sodium and fluid supplements.

There is a hereditary metabolic defect

of the human adrenal which renders it defective in producing hydrocortisone. This is the adrenogenital syndrome. In these patients the adrenals produce excessive amounts of intermediate products which are excreted in the urine. Some of these compounds are androgenic 17-ketosteroids and may cause virilization (Bradbury, 1958). These androgens tend to inhibit the gonadotrophic activity of the pituitary and leave the ovaries unstimulated and infantile (Fig. 7.13). Replacement therapy with corticoids reduces the adrenocorticotrophic hormone (ACTH) activity of the pituitary and then the adrenal production of androgen ceases. This then permits the pituitary to stimulate normal cyclic activity in the ovaries (Fig. 7.14). The adrenogenital syndrome thus has a profound effect on ovarian function which is specific through its production of androgen. More complete descriptions of the condition and of the rationale of treatment have been prepared by Wilkins (1949),

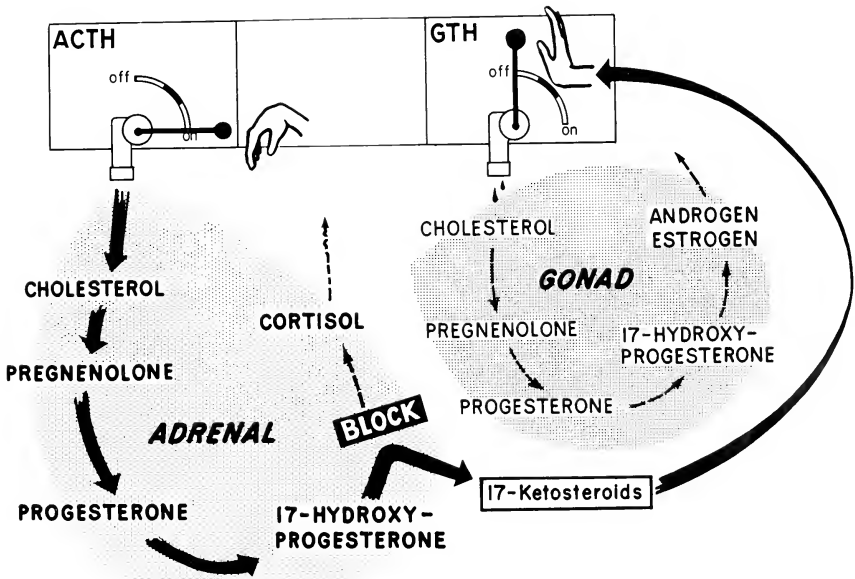

FIG. 7.13. Schematic representation of the interaction of the adrenal and the ovary in the adrenogenital syndrome. The process of hormone biosynthesis is defective in the adrenal (BLOCK) and the degraded by-products (17-ketosteroids) being androgenic suppress the formation of gonadotrophins (GTH). (Courtesy of Dr. J. T. Bradbury.)

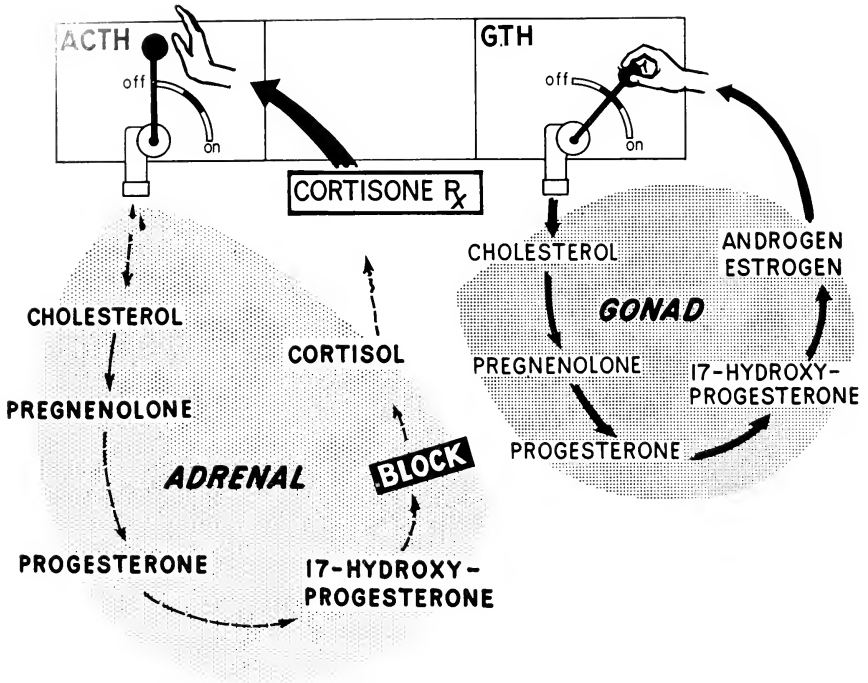

Fig. 7.11. Treatment with cortisone (or other glucocorticoid) reduces ACTH production and adrenal hormone synthesis subsides. This permits the normal pituitary-gonadal interactions to be established. (Courtesy of Dr. J. T. Bradbury.)

Wilkins, Crigler, Silverman, Gardner and Migeon (1952), and Bradbury (1958). Milder categories of what is believed to be adrenal cortical hyperplasia have also been described and are responsive to treatment with cortisone. They are characterized by amenorrhea or oligomenorrhea, hirsutism, slightly elevated 17-ketosteroid excretion values, and difficulty in becoming pregnant (Jones, Howard and Langford, 1953; Jefferies, Weir, Weir and Prouty, 1958; Jefferies, 1960). Indications are that these abnormalities, like those typical of the adrenogenital syndrome, affect the ovary, not directly, but rather by the creation of a pituitary gonadotrophic-ovarian imbalance.

Some evidence exists for more direct relationships between the adrenal cortex and the ovary. These may involve actions of ovarian hormones on the adrenal, and ac-

tions of adrenal cortical hormones on the ovary. In general, however, the relationships are tenuous or at least not sharply defined. It is evident from the review by Parkes (1945) that sexual dimorphism in adrenal cortical structure has been demonstrated in a number of species, notably the mouse and rat and possibly the guinea pig, but it has not been detected in a number of other species. The effects of gonadectomy and the injection of hormones, particularly estrogens, into gonadectomized animals are less clear, but they are suggestive of an action on the adrenal, however ill defined and variable it seems to be. A seasonal hypertrophy of the adrenal has been reported as occurring in the mole, *Talpa europaea*, (Kolmer, 1918) and the ground squirrel, *Citellus tridecemlineatus* (Mitchill), (Foster, 1934), as has enlargement at the time of estrus in the rat (Andersen and Kennedy,

1932; Bourne and Zuckerman, 1941b). More recently, a significantly higher excretion of 17-hydroxycorticosteroids has been found during the second and third weeks, and therefore during the luteal phase, of the menstrual cycle (Maengwyn-Davies and Weiner, 1955).

Whether a causal relationship exists between these indications of a fluctuating activity within the adrenal cortex, and seasonal and cyclic changes within the ovaries remains to be determined. Little information exists. Bourne and Zuckerman (*loc. cit.*) described the changes in the adrenals of ovariectomized rats injected with estrone and concluded that the changes are independent of the gonads. Foster's observation that the active appearance of the adrenal can be seen during pregnancy as well as during estrus suggests, but does not prove, that there is a hormonal regulation in the ground squirrel which is dependent on reproductive processes.

Data with respect to possible direct effects of adrenal cortical secretions on the ovary are ambiguous. Cortisone acetate administered to rabbits 5 to 33 days in daily doses of 5 to 20 mg. did not inhibit the ovulation which occurs after mating or after the injection of copper acetate (De Costa and Abelman, 1953). The ability of the ovary of the rat to respond after adrenalectomy was tested by the administration of gonadotrophic extracts (Brolin and Lindbäck, 1951). They found that the ovaries could be stimulated to increase the weight of the uterus without the cooperation of the adrenals and considered that this result does not support the view that there is a direct relationship between adrenal corticoids and the biosynthesis of ovarian (also testicular) hormones. In other experiments (Payne, 1951; Smith, 1955), adrenalectomy abolished (Payne) or interfered significantly (Smith) with the ovarian hyperemia response to injections of HCG and pituitary extract (Antuitrin T), the response utilized by Farris (1946) as a test for early pregnancy. Cortisone and hydrocortisone were partially effective in restoring the response in adrenalectomized animals. According to Payne, isocortisone acetate and compound A acetate were also effective, but in larger doses. No report of the use of corticosterone

(compound B) is given; replacement therapy with this hormone would have been more physiologic because it is the natural corticoid of rats. It was concluded that the hyperemia response is more nearly normal in animals with normal adrenal function; Payne believes that the response is mediated through this gland. Despite what seem to be clear-cut results which have been confirmed, it is felt that additional closely controlled experiments must be done in order to show whether these adrenal hormones affect the ovary directly or whether most of the effects are nonspecific metabolic alterations.

### VIII. Concluding Remarks

The avenue followed by investigators interested in the functioning of the mammalian ovary has long carried a two-way traffic. In addition, there has been movement into the out of many side streets. No understanding of the pattern of the traffic in such a situation is possible and no satisfactory regulation can be achieved unless something is known about the nature, origin, and destination of the vehicles composing the traffic. Equally important, this information cannot be obtained by standing on one spot. This analogy contains much that is relevant for what has been attempted in this book. The problem of the ovary has been approached from the vantage point of forces and substances originating in the pituitary and the environment which act centripetally on it (Greep, Everett), and from the vantage point of many of the tissues and organs on which the hormones we associate with it exert their action (the Hisaws, Cowie and Folley, Zarrow, Young in his chapter on mating behavior). In this chapter and that prepared by Dr. Vilee positions have been taken near the ovary and attempts made to bring together much of the information gathered by investigators who were in a sense looking right at it.

Whether our perspective is developed from a familiarity with all the material which has been brought together or whether it is restricted by the narrower treatment given here, it is obvious that the unsolved problems outnumber by far any that have been solved, if indeed there are such. We have learned much about the functioning

of the ovary, but there is little we can explain. As we indicated earlier, a part of this failure can be ascribed to the lack of gonadotrophic preparations which either singly or in combination will evoke changes identical with those in untreated normal animals, but this chapter alone contains an enumeration of many other problems solution of which does not depend on this particular advance. The disappointment we express may be a reflection of what seems to be the *modus operandi* in science. The extent of our application to unsolved problems is very unequal, but more often than not it can be traced to an investigator's success in achieving a "breakthrough"<sup>6</sup> as Edgar Allen, Doisy, Smith and Engle, Willard Allen and Corner, Hisaw and other colleagues did in the twenties. At such a time, enthusiasm is intense and there follows a period of gratifying accomplishment, but obstacles are encountered and often interest lags, until another breakthrough occurs. In the meantime, effort may have been diverted by discoveries elsewhere and the area of investigation which attracted so many is neglected and suffers. Ovarian physiology should not remain in this state for long. There is no tissue of the body in which the changes are as conspicuous and as dramatic as those in the ovary and there is no tissue which presents more variable aspects. Many of the stages in the cycle of ovarian structure and functioning are related to changes elsewhere in the body—changes in growth, in motility, in secretion, and in behavior. All these changes, including those within the ovaries, offer excellent end points for continued quantitative and qualitative studies.

### IX. References

ALDMAN, B., CLAESSON, L., HILLARP, N.-Å., AND ODEBLAD, E. 1949. Studies on the storage mechanism of oestrogen-precursors. *Acta endocrinol.*, **2**, 24-32.

ALLEN, E. 1922. The oestrous cycle in the mouse. *Am. J. Anat.*, **30**, 297-371.

ALLEN, E. 1932. The ovarian follicular hormone, theelin; animal reactions. In *Sex and Internal Secretions*, 1st ed., E. Allen, Ed., pp. 392-480. Baltimore: The Williams & Wilkins Company.

ALLEN, W. M. 1939. *Biochemistry of the corpus*

luteum hormone, progesterone. In *Sex and Internal Secretions*, 2nd ed., E. Allen, C. H. Danforth and E. A. Doisy, Eds., pp. 901-928. Baltimore: The Williams & Wilkins Company.

AMOROSO, E. C. 1955. Endocrinology of pregnancy. *Brit. Med. Bull.*, **11**, 117-125.

AMOROSO, E. C., HARRISON, R. J., HARRISON-MATTHEWS, L., AND ROWLANDS, I. W. 1951. Reproductive organs of near-term and new-born seals. *Nature*, London, **168**, 771-772.

AMOROSO, E. C., AND ROWLANDS, I. W. 1951. Hormonal effects in the pregnant mare and foetal foal. *J. Endocrinol.*, **7**, 1-111.

ANDERSEN, D. H., AND KENNEDY, H. S. 1932. Studies on the physiology of reproduction. IV. Changes in the adrenal gland of the female rat associated with the oestrous cycle. *J. Physiol.*, **76**, 247-260.

ANTONIADES, H. N., McARTHUR, J. W., PENNELL, R. B., INGERSOLL, F. M., UFFELDER, H., AND ONCLEY, J. L. 1957. Distribution of infused estrone in human plasma. *Am. J. Physiol.*, **189**, 455-459.

ARON, M., AND ARON, C. 1952. La glande thécale de l'ovaire de cobaye. *Arch. Anat. Histol. et Embryol.*, **34**, 27-41.

ASCHHEIM, S., PORTES, L., AND MAYER, M. 1939. Les hormones gonadotropes. Étude critique de quelques points relatifs à leur role dans la physiologie et la pathologie des fonctions de l'ovaire. *Ann. endocrinol.*, **1**, 42-54.

ASTWOOD, E. B. 1938. A six-hour assay for the quantitative determination of estrogen. *Endocrinology*, **23**, 25-31.

ASTWOOD, E. B. 1939. Changes in the weight and water content of the uterus of the normal adult rat. *Am. J. Physiol.*, **126**, 162-170.

ATKINSON, W. B., AND LEATHAM, J. H. 1946. The day to day level of estrogen and progesterin during lactation in the mouse. *Anat. Rec.*, **95**, 147-155.

BARAONA, M., BRUZZONE, S., AND LIPSCHUTZ, A. 1950. On the control of follicular development in intrasplenic ovarian grafts by minute quantities of oestrogen. *Endocrinology*, **46**, 407-413.

BARKER, W. L. 1951. A cytochemical study of lipids in sows' ovaries during the estrous cycle. *Endocrinology*, **48**, 772-785.

BARRCLOUGH, C. A. 1955. Influence of age on the response of preweaning female mice to testosterone propionate. *Am. J. Anat.*, **95**, 493-521.

BASSETT, D. L. 1943. The changes in the vascular pattern of the ovary of the albino rat during the estrous cycle. *Am. J. Anat.*, **73**, 251-291.

BAYLIS, R. I., BROWNE, J. C., ROUND, B. P., AND STEINBECK, A. W. 1955. Plasma 17-hydroxycorticosteroids in pregnancy. *Lancet*, **1**, 62-67.

BERGER, M. 1935. Besonders hohe Wirksamkeit des Follikelhormons bei vaginaler Instillation. *Klin. Wchenschr.*, **14**, 1601-1602.

BERGMAN, P. 1949. Sexual cycle, time of ovulation, and time of optimal fertility in women.

<sup>6</sup> The word was not a part of the language of science at that time and probably was never used by them.



- Acta obst. et gynec. scandinav., Suppl. 29, 4, 1-139.
- BEYER, K. F., AND SAMUELS, L. T. 1956. Distribution of steroid-3 $\beta$ -ol-dehydrogenase in cellular structures of the adrenal gland. *J. Biol. Chem.*, **219**, 69-76.
- BIGGERS, J. D. 1953. The characteristics of the dose-response line in Allen-Doisy tests obtained by the intravaginal administration of oestrone in distilled water and in 50 per cent aqueous glycerol. *J. Endocrinol.*, **9**, 145-154.
- BIGGERS, J. D., AND CLARINGBOLD, P. J. 1954. Optimum conditions for the local (intravaginal) action of oestrogens. *Australian J. Biol.*, **7**, 118-139.
- BIGGERS, J. D., AND CLARINGBOLD, P. J. 1955. Mitotic activity in the vaginal epithelium of the mouse following local oestrogenic stimulation. *J. Anat.*, **89**, 124-131.
- BITMAN, J., WRENN, T. R., AND SYKES, J. F. 1958. Estrogen determination in blood and body fluids of cattle. In *Reproduction and Infertility*, III, Symposium, F. X. Gassner, Ed., pp. 141-156. New York: Pergamon Press.
- BLANDAUI, R. J. 1955. Ovulation in the living albino rat. *Fertil. & Steril.*, **6**, 391-404.
- BLANDAUI, R. J., AND SODERWALL, A. L. 1941. Post-parturitional heat and the time of ovulation in the albino rat. Data on parturition. *Anat. Rec.*, **81**, 419-430.
- BLOCK, E. 1951a. Quantitative morphological investigations of the follicular system in women. Methods of quantitative determinations. *Acta Anat.*, **12**, 267-285.
- BLOCK, E. 1951b. Quantitative morphological investigations of the follicular system in women. Variations in the different phases of the sexual cycle. *Acta endocrinol.*, **8**, 33-54.
- BLOCK, E. 1952. Quantitative morphological investigations of the follicular system in women. Variations at different ages. *Acta anat.*, **14**, 108-123.
- BLOCK, E. 1953. A quantitative morphological investigation of the follicular system in newborn female infants. *Acta anat.*, **17**, 201-206.
- BOGDANOV, E. M., AND HORN, E. H. 1958. Thyroid iodide concentration in estradiol-treated hypophysectomized rats. *Endocrinology*, **62**, 97-99.
- BOLING, J. L. 1942. Growth and regression of corpora lutea during the normal estrous cycle of the rat. *Anat. Rec.*, **82**, 131-145.
- BOLING, J. L., BLANDAUI, R. J., WILSON, J. G., AND YOUNG, W. C. 1939. Post-parturitional heat responses of newborn and adult guinea pigs. Data on parturition. *Proc. Soc. Exper. Biol. & Med.*, **42**, 128-132.
- BOLING, J. L., BLANDAUI, R. J., SODERWALL, A. L., AND YOUNG, W. C. 1941. Growth of the Graafian follicle and the time of ovulation in the albino rat. *Anat. Rec.*, **79**, 313-331.
- BOS, C., AND CLEGHORN, R. A. 1958. Psychogenic sterility. *Fertil. & Steril.*, **9**, 84-98.
- BOURNE, G., AND ZUCKERMAN, S. 1941a. The influence of the adrenals on cyclical changes in the accessory reproductive organs of female rats. *J. Endocrinol.*, **2**, 268-282.
- BOURNE, G., AND ZUCKERMAN, S. 1941b. Changes in the adrenals in relation to the normal and artificial threshold oestrous cycle in the rat. *J. Endocrinol.*, **2**, 283-310.
- BRADBURY, J. T. 1947. Ovarian influence on the response of the anterior pituitary to estrogens. *Endocrinology*, **41**, 501-513.
- BRADBURY, J. T. 1958. Adrenogenital syndrome and adrenal hyperplasia. *Clin. Obst. & Gynec.*, **1**, 257-270.
- BRADBURY, J. T. 1961. Direct action of estrogen on the ovary of the immature rat. *Endocrinology*, **68**, 115-120.
- BRADBURY, J. T., AND GAENSBAUER, F. 1939. Masculinization of the female rat by gonadotrophic extracts. *Proc. Soc. Exper. Biol. & Med.*, **41**, 128-131.
- BRADBURY, J. T., BROWN, W. E., AND GRAY, L. A. 1950. Maintenance of the corpus luteum and physiologic actions of progesterone. *Recent Progr. Hormone Res.*, **5**, 151-194.
- BRAMBELL, F. W. R. 1956. Ovarian changes. In *Marshall's Physiology of Reproduction*, 3rd ed., A. S. Parkes, Ed., Vol. 1, Part 1, pp. 397-542. London: Longmans, Green & Company.
- BRAMBELL, F. W. R., AND PARKES, A. S. 1927. Changes in the ovary of the mouse following exposure to x-rays. III. Irradiation of the non-parous adult. *Proc. Roy. Soc. London, Ser. B*, **101**, 316-328.
- BREWER, J. I. 1942. Studies of the human corpus luteum. Evidence for the early onset of regression of the corpus luteum of menstruation. *Am. J. Obst. & Gynec.*, **44**, 1048-1062.
- BROLIN, S. E., AND LINDBÄCK, M. 1951. The reacting capacity of the gonads after adrenalectomy as judged by the response to gonadotrophins in the rat. *Acta endocrinol.*, **8**, 55-71.
- BROWN, J. B. 1955. A chemical method for determination of oestriol, oestrone, and oestradiol in human urine. *Biochem. J.*, **60**, 185-195.
- BROWN, J. H., AND LUTHER, H. G. 1951. Results of rebreeding sows three days after farrowing—effect of gonadotrophic hormone on litter size, boar acceptance, fertility, etc. *J. Anim. Sc.*, **10**, 1022.
- BROWN-GRANT, K. 1956. Gonadal function and thyroid activity. *J. Physiol.*, **131**, 70-84.
- BRUCE, H. M., AND SLOVITER, H. A. 1957. Effect of destruction of thyroid tissue by radioactive iodine on reproduction in mice. *J. Endocrinol.*, **15**, 72-82.
- BRYANS, F. E. 1951. Progesterone of the blood in the menstrual cycle of the monkey. *Endocrinology*, **48**, 733-740.
- BUCHHOLZ, R., DIBBELT, L., AND SCHILD, W. 1954. Über die Bildung des Progesterons in menschlichen Zyklus. *Geburtsh. u. Frauenh.*, **14**, 620-636.
- BULBROOK, R. D., AND GREENWOOD, F. C. 1957. Persistence of urinary oestrogen excretion after oophorectomy and adrenalectomy. *Br. M. J.*, **1**, 662-666.
- BULLOUGH, W. S. 1942a. Gametogenesis and

- some endocrine factors affecting it in the adult minkow (*Phoxinus laevis* L.). *J. Endocrinol.*, **3**, 211-219.
- BULLOUGH, W. S. 1942b. Oogenesis and its relation to the oestrous cycle in the adult mouse. *J. Endocrinol.*, **3**, 141-149.
- BULLOUGH, W. S. 1942c. The method of growth of the follicle and corpus luteum in the mouse ovary. *J. Endocrinol.*, **3**, 150-156.
- BULLOUGH, W. S. 1943. The effects of oestrone on the ovary of the mouse. *J. Endocrinol.*, **3**, 235-243.
- BURKL, W. V., KELLNER, G., LINDNER, A., AND SPRINGER, K. 1954. Über die Neubildung von Follikeln im Rattenovar im Verlauf einer chronischen Hexöströlbildung. *Ztschr. mikro-anat. Forsch.*, **61**, 37-65.
- BURKL, W. V., AND KELLNER, G. 1956. Das Wachstum der Follikel und die Reifung der Eizellen in den verschiedenen Zyklusphasen bei der Ratte. *Acta Anat.*, **27**, 309-323.
- BUXTON, C. L. 1950. The atypical secretory phase. In *Menstruation and Its Disorders*. E. T. Engle, Ed., pp. 270-288. Springfield, Ill.: Charles C Thomas.
- BUXTON, C. L., AND ENGLE, E. T. 1950. Time of ovulation. A correlation between basal temperature, the appearance of the endometrium, and the appearance of the ovary. *Am. J. Obst. & Gynec.*, **60**, 539-551.
- CATCHPOLE, H. R., GERSH, I., AND PAN, S. C. 1950. Some properties of ovarian connective tissue in relation to parenchymatous changes. *J. Endocrinol.*, **6**, 277-281.
- CHAMORRO, A. 1943. Sécrétion de substance androgène par l'ovaire de la souris normale, sous l'action d'extrait gonadotrope équine. *Compt. rend. Soc. biol.*, **137**, 108-109.
- CHUQUENE, A. D. 1959. Electron microscopic observations on the developmental cytology of the mammalian ovum (Abstr.). *Proc. Am. A. Anat.*, *Anat. Rec.*, **133**, 258.
- CHU, J. P., LEE, C. C., AND YOU, S. S. 1946. Functional relation between the uterus and the corpus luteum. *J. Endocrinol.*, **4**, 392-398.
- CLAESSON, L. 1947. Is there any smooth musculature in the wall of the Graafian follicle? *Acta Anat.*, **3**, 295-311.
- CLAESSON, L. 1954. Quantitative relationship between gonadotrophic stimulation and lipid changes in the interstitial gland of the rabbit ovary. *Acta physiol. scandinav.*, Suppl. 113, **31**, 23-51.
- CLAESSON, L., DICZFALUSY, E., HILLARP, N.-Å., AND HÖGGERG, B. 1948. The formation mechanism of oestrogenic hormones. III. Lipids of the pregnant rabbit ovary and their changes at gonadotrophic stimulation. *Acta physiol. scandinav.*, **16**, 183-200.
- CLAESSON, L., AND HILLARP, N.-Å. 1947a. The formation mechanism of oestrogenic hormones. I. The presence of an oestrogen-precursor in the rabbit ovary. *Acta physiol. scandinav.*, **13**, 115-129.
- CLAESSON, L., AND HILLARP, N.-Å. 1947b. The formation mechanism of oestrogenic hormones. II. The presence of the oestrogen-precursor in the ovaries of rats and guinea pigs. *Acta physiol. scandinav.*, **14**, 102-119.
- CLAESSON, L., AND HILLARP, N.-Å. 1947c. Critical remarks on the histochemical reactions for ketosteroids. *Acta anat.*, **3**, 109-114.
- CLAESSON, L., HILLARP, N.-Å., HÖGGERG, B., AND HÖKFELT, B. 1949. Changes in the ascorbic acid content in the interstitial gland of the rabbit ovary following gonadotrophic stimulation. *Acta endocrinol.*, **2**, 249-256.
- COCHRANE, R. L., AND MEYER, R. K. 1957. Delayed nidation in the rat induced by progesterone. *Proc. Soc. Exper. Biol. & Med.*, **96**, 155-159.
- COHEN, M. R., AND HANKIN, H. 1960. Detecting ovulation. *Fertil. & Steril.*, **11**, 497-507.
- COHEN, S. M. 1959. Fate of progesterone injected subcutaneously in mice. *Endocrinology*, **65**, 971-972.
- COLE, H. H., HART, G. H., LYONS, W. R., AND CATCHPOLE, H. R. 1933. The development and hormonal content of fetal horse gonads. *Anat. Rec.*, **56**, 275-293.
- COLE, H. H., HOWELL, C. E., AND HART, G. H. 1931. The changes occurring in the ovary of the mare during pregnancy. *Anat. Rec.*, **49**, 199-209.
- COLE, H. H., AND MILLER, R. F. 1933. Artificial induction of ovulation and oestrus in the ewe during anoestrus. *Am. J. Physiol.*, **104**, 165-171.
- CORDIEZ, E. 1949. Le moment de l'ovulation dans l'espèce bovine. *Ann. Méd. Vét.*, **93**, 65-73.
- COREY, E. L. 1928. Effect of prenatal and postnatal injections of the pituitary gland in the white rat. *Proc. Soc. Exper. Biol. & Med.*, **25**, 498-499.
- CORNER, G. W. 1937. The rate of secretion of progesterin by the corpus luteum. *Cold Spring Harbor Symposia Quant. Biol.*, **5**, 62-65.
- CORNER, G. W. 1938. The sites of formation of oestrogenic substances in the animal body. *Physiol. Rev.*, **18**, 154-172.
- CORNER, G. W. 1940. The rate of secretion of oestrogenic hormones by the ovaries of the monkey, *Macaca rhesus*. *Bull. Johns Hopkins Hosp.*, **67**, 407-413.
- CORNER, G. W. 1945. Development, organization, and breakdown of the corpus luteum in the rhesus monkey. *Contr. Embryol.*, Carnegie Inst. Washington, **31**, 117-146.
- CORNER, G. W., JR. 1956. The histological dating of the human corpus luteum of menstruation. *Am. J. Anat.*, **98**, 377-392.
- COURRIER, R. 1950. Interactions between estrogens and progesterone. *Vitamins & Hormones*, **8**, 179-214.
- D'AMOUR, F. E. 1943. A comparison of methods used in determining the time of ovulation. *J. Clin. Endocrinol.*, **3**, 41-48.
- DANOWSKI, T. S., GOW, R. C., MATEER, F. M., EVERHART, W. C., JOHNSON, S. Y., AND GREEN-

- MAN, J. H. 1950. Increases in serum thyroxin during uncomplicated pregnancy. *Proc. Soc. Exper. Biol. & Med.*, **74**, 323-325.
- DAUGHADAY, W. H. 1958. Binding of corticosteroids by plasma proteins. V. Corticosteroid-binding globulin activity in normal human beings and in certain disease states. *A. M. A. Arch. Int. Med.*, **101**, 286-290.
- DAUGHADAY, W. H. 1959. Steroid protein interactions. *Physiol. Rev.*, **39**, 885-902.
- DAVIS, M. E., AND PLOTZ, E. J. 1957. Progesterone, the pregnancy hormone. *Fertil. & Steril.*, **8**, 603-618.
- DAVIS, M. E., PLOTZ, E. J., LUPU, C. I., AND EJARQUE, P. M. 1960. The metabolism of progesterone and its related compounds in human pregnancy. *Fertil. & Steril.*, **11**, 18-48.
- DAWSON, A. B. 1946. The postpartum history of the corpus luteum of the cat. *Anat. Rec.*, **95**, 29-51.
- DAWSON, A. B., AND McCABE, M. 1951. The interstitial tissue of the ovary in infantile and juvenile rats. *J. Morphol.*, **88**, 543-571.
- DE ALENDE, I. L. C. 1956. Anovulatory cycles in women. *Am. J. Anat.*, **98**, 293-305.
- DEANE, H. W. 1952. Histochemical observations on the ovary and oviduct of the albino rat during the estrous cycle. *Am. J. Anat.*, **91**, 363-413.
- DEANESLY, R. 1938a. The androgenic activity of ovarian grafts in castrated male rats. *Proc. Roy. Soc. London, ser. B*, **126**, 122-135.
- DEANESLY, R. 1938b. Reproductive cycle of the golden hamster (*Cricetus auratus*). *Proc. Zool. Soc. London, Ser. A*, **108**, 31-37.
- DE COSTA, E. J., AND ABELMAN, M. A. 1953. Effect of cortisone on ovulation in the rabbit. *Obst. & Gynec.*, **1**, 269-275.
- DEL CASTILLO, E. B., AND CALATRONI, C. J. 1930. Cycle sexuel périodique et folliculine. *Compt. rend. Soc. biol.*, **104**, 1024-1028.
- DEMPSEY, E. W. 1937. Follicular growth rate and ovulation after various experimental procedures in the guinea pig. *Am. J. Physiol.*, **120**, 126-132.
- DEMPSEY, E. W. 1939. Maturation and cleavage figures in ovarian ova. *Anat. Rec.*, **75**, 223-235.
- DEMPSEY, E. W. 1948. The chemical cytology of endocrine glands. *Recent Progr. Hormone Res.*, **3**, 127-157.
- DEMPSEY, E. W., HERTZ, R., AND YOUNG, W. C. 1936. The experimental induction of oestrus (sexual receptivity) in the normal and ovariectomized guinea pig. *Am. J. Physiol.*, **116**, 201-209.
- DEMPSEY, E. W., AND BASSETT, D. L. 1943. Observations on the fluorescence, birefringence and histochemistry of the rat ovary during the reproductive cycle. *Endocrinology*, **33**, 384-401.
- DESAYE, P. 1948. Contribution à l'étude du mécanisme de l'évolution et de l'involution folliculaires dans l'ovaire de lapine adulte (Deuxième partie). *Arch. Biol., Paris*, **59**, 31-146.
- DESCLIN, L. 1947. Concerning the mechanism of diestrus during lactation in the albino rat. *Endocrinology*, **10**, 14-29.
- DESCLIN, L. 1949. Action des oestrogènes sur l'ovaire chez le rat normal et hypophyséctomisé. *Compt. rend. Soc. biol.*, **143**, 1004-1006.
- DESCLIN, L. 1955. Action androgénique locale de greffes ovariennes intraspinales chez le rat. *Compt. rend. Soc. biol.*, **149**, 2017-2020.
- DE WIT, J. C. 1953. The effect of oestradiol monobenzoate on follicles of various sizes in the ovary of the hypophyséctomized rat. *Acta endocrinol.*, **12**, 123-139.
- DIAMOND, M. 1960. Comparative behavioral and structural effects of androgen injected into pregnant and non pregnant guinea pigs (Abstract). *Proc. Am. Soc. Zool., Anat. Rec.*, **137**, 349.
- DICKIE, M. M., ATKINSON, W. B., AND FEKETE, E. 1957. The ovary, estrous cycle and fecundity of DBA × CE and reciprocal hybrid mice in relation to age and the hyperovarian syndrome. *Anat. Rec.*, **127**, 187-199.
- DODDS, C. 1955. Synthetic oestrogens. *Brit. M. Bull.*, **11**, 131-134.
- DOISY, E. A. 1939. Biochemistry of the estrogenic compounds. In *Sex and Internal Secretions*, 2nd ed. E. Allen, C. H. Danforth and E. A. Doisy, Eds., pp. 846-876. Baltimore: The Williams & Wilkins Company.
- DORNFELD, E. J., AND BERRIAN, J. H. 1951. Stimulation of mitoses in the germinal epithelium of rat ovaries by intracapsular injections. *Anat. Rec.*, **109**, 129-137.
- DOWLING, J. T., FREINKEL, N., AND INGBAR, S. H. 1956a. Thyroxine-binding by sera of pregnant women. *J. Clin. Endocrinol.*, **16**, 280-281.
- DOWLING, J. T., FREINKEL, N., AND INGBAR, S. H. 1956b. Effect of diethylstilbestrol on the binding of thyroxine in serum. *J. Clin. Endocrinol.*, **16**, 1491-1506.
- DOYLE, J. B. 1951. Exploratory culdotomy for observation of tubo-ovarian physiology at ovulation time. *Fertil. & Steril.*, **2**, 474-486.
- DUBREUIL, G. 1942. Nature épithéliale des cellules folliculeuses et nature mésenchymateuse des cellules thécales du follicule de Graaf. *Ann. endocrinol.*, **3**, 179-181.
- DUBREUIL, G. 1948. Sur l'existence d'une substance inductrice à action limitée et locale pour la métaplasie thécale des cellules du stroma cortical ovarien. *Ann. endocrinol.*, **9**, 434-436.
- DUBREUIL, G. 1950. Les glandes endocrines de l'ovaire féminin. Leur variabilité, leurs variations d'après des observations morphologiques personnelles. *Gynéc. et Obst.*, **49**, 282-292.
- DUKE, K. L. 1949. Some notes on the histology of the ovary of the bobcat (*Lynx*) with special reference to the corpora lutea. *Anat. Rec.*, **103**, 111-129.
- DUKES, H. H. 1943. *The Physiology of Domestic Animals*, 5th ed. Ithaca: Comstock Publishing Company.

- DUNCAN, G. W., BOWERMAN, A. M., HEARN, W. R., AND MELAMPY, R. M. 1960. *In vitro* synthesis of progesterone by swine corpora lutea. Proc. Soc. Exper. Biol. & Med., **104**, 17-19.
- JUYVENÉ DE WIT, J. J. 1942. Über das Vorkommen des Progesterons im Follikelsaft des Schweines, des Rindes und der Frau. Arch. Gynäk., **172**, 455-464.
- EDGAR, D. G. 1953a. The chemical assay of progesterone. Biochem. J., **54**, 50-55.
- EDGAR, D. G. 1953b. The progesterone content of body fluids and tissues. J. Endocrinol., **10**, 54-64.
- EDGAR, D. G., AND RONALDSON, J. W. 1958. Blood levels of progesterone in the ewe. J. Endocrinol., **16**, 378-384.
- EIK-NES, K., SCHELLMAN, J. A., LUMRY, R., AND SAMUELS, L. T. 1954. The binding of steroids to protein. I. Solubility determinations. J. Biol. Chem., **206**, 411-419.
- EMMENS, C. W. 1950a. Estrogens. In *Hormone Assay*, C. W. Emmens, Ed., pp. 391-417. New York: Academic Press, Inc.
- EMMENS, C. W. 1950b. Hormones of the corpus luteum. In *Hormone Assay*, C. W. Emmens, Ed., pp. 419-441. New York: Academic Press, Inc.
- ENGLE, E. T. 1955. Aspects of aging as reflected in the human ovary and testis. Recent Progr. Hormone Res., **11**, 291-306.
- ENGLE, E. T., AND SHELESNYAK, M. C. 1934. First menstruation and subsequent menstrual cycles of pubertal girls. Human Biol., **6**, 431-453.
- ENGSTROM, W. W., MARKARDT, B., AND LIEBMAN, A. 1952. Effect of estrogens on serum precipitable iodine. Proc. Soc. Exper. Biol. & Med., **81**, 582-584.
- ENGSTROM, W. W., AND MARKARDT, B. 1954. Influence of estrogen on thyroid function. J. Clin. Endocrinol., **14**, 215-222.
- ESAKI, S. 1928. Über Kulturen des Hodengewebes der Säugtiere und über die Natur des interstitiellen Hodengewebes und der Zwischenzellen. Ztschr. mikro-anat. Forsch., **15**, 368-404.
- EVANS, H. M., AND COLE, H. H. 1931. An introduction to the study of the oestrous cycle in the dog. Mem. Univ. California, **9**, 65-118.
- EVANS, H. M., SIMPSON, M. E., TOLKSDORF, S., AND JENSEN, H. 1939. Biological studies of the gonadotrophic principles of sheep pituitary substance. Endocrinology, **25**, 529-546.
- EVERETT, J. W. 1947. Hormonal factors responsible for the deposition of cholesterol in the corpus luteum of the rat. Endocrinology, **41**, 364-377.
- EVERETT, J. W. 1956. Functional corpora lutea maintained for months by autografts of rat hypophysis. Endocrinology, **58**, 786-796.
- FARBMAN, A. A. 1944. Effect of estrogenic hormone on hyperthyroidism. J. Clin. Endocrinol., **4**, 17-22.
- FARRIS, E. J. 1946. A test for determining the time of ovulation and conception in women. Am. J. Obst. & Gynec., **52**, 14-27.
- FARRIS, E. J. 1948. The prediction of the day of human ovulation by the rat test as confirmed by fifty conceptions. Am. J. Obst. & Gynec., **56**, 347-352.
- FARRIS, E. J. 1952. A formula for selecting the optimum time for conception. Am. J. Obst. & Gynec., **63**, 1143-1146.
- FELDMAN, J. D. 1956a. Effect of estrus and estrogen on thyroid uptake of  $I^{131}$  in rats. Endocrinology, **58**, 327-337.
- FELDMAN, J. D. 1956b. Effect of estrogen on thyroidal iodide trapping and conversion of inorganic  $I^{131}$  to protein-bound  $I^{131}$ . Endocrinology, **59**, 289-292.
- FELDMAN, J. D., AND DANOWSKI, T. S. 1956. Effect of estrogen on the metabolism of protein-bound iodine. Endocrinology, **59**, 463-471.
- FERRET, P. 1950. The effect of diet on oestrogen inactivation by the liver. Brit. J. Exper. Path., **31**, 590-596.
- FETZER, S., HILLEBRECHT, J., MUSCHKE, H.-E., AND TONUTTI, E. 1955. Hypophysäre Steuerung der Interstitiellen Zellen des Rattenovariums, quantitativ betrachtet am Zellkernvolumen. Ztschr. Zellforsch., **43**, 404-420.
- FISCHER, R. H., AND RILEY, C. L. 1952. Pregnanediol excretion in a masculinizing syndrome. J. Clin. Endocrinol., **12**, 890-900.
- FOLLEY, S. J., AND MALPRESS, F. H. 1944. The response of the bovine ovary to pregnant mares' serum and horse pituitary extract. Proc. Roy. Soc. London, ser. B, **132**, 164-188.
- FOLLEY, S. J., GREENBAUM, A. L., AND ROY, A. 1949. The response of the ovary of the anoestrous goat to pregnant mares' serum gonadotrophin. J. Endocrinol., **6**, 121-131.
- FORBES, T. R. 1950. Systemic plasma progesterone levels during the human menstrual cycle. Am. J. Obst. & Gynec., **60**, 180-186.
- FORBES, T. R. 1953. Pre-ovulatory progesterone in the peripheral blood of the rabbit. Endocrinology, **53**, 79-87.
- FORD, D. H., AND YOUNG, W. C. 1953. Duration of the first cyclic vaginal openings in maturing guinea pigs and related ovarian conditions. Anat. Rec., **115**, 495-504.
- FORD, D. H., AND HIRSCHMAN, A. 1955. Alkaline phosphatase activity in the ovaries of immature and maturing albino rats. Anat. Rec., **121**, 531-547.
- FOSTER, M. A. 1934. The reproductive cycle in the female ground squirrel, *Citellus tridecemlineatus* (Mitchill). Am. J. Anat., **54**, 487-511.
- FOSTER, M. A., FOSTER, R. C., AND HISAW, F. L. 1937. The interrelationship of the pituitary sex hormones in ovulation, corpus luteum formation, and corpus luteum secretion in the hypophysectomized rabbit. Endocrinology, **21**, 249-259.
- FURUJELMI, M. 1954. The oestrogenic function of the corpus luteum. Acta endocrinol., **17**, 85-88.
- GAARENSTROOM, J. H., AND DE JONGH, S. E. 1946. *Contribution to the Knowledge of the Influences of Gonadotropic and Sex Hormones*

- on the Gonads of Rats. Amsterdam: Elsevier Publishing Company.
- GARNIER, M. 1921. Les relations fonctionnelles de la thyroïde avec les autres glandes à sécrétion interne. *J. Med. franc.*, **10**, 450-457.
- GENTHER, I. T. 1931. Irradiation of the ovaries of guinea-pigs and its effect on the oestrous cycle. *Am. J. Anat.*, **48**, 99-137.
- GILLMAN, J. 1942. A quantitative study of the bleeding threshold and optimum estrogen requirements in the baboon (*Papio porcarius*). *Endocrinology*, **31**, 172-178.
- GILLMAN, J., AND GILBERT, C. 1946. The reproductive cycle of the chaema baboon (*Papio ursinus*) with special reference to the problems of menstrual irregularities as assessed by the behaviour of the sex skin. *South African J. M. Sc.*, **11**, Biol. Suppl.
- GRANT, R. 1934. Studies on the physiology of reproduction in the ewe. *Tr. Roy. Soc. Edinburgh*, **58**, 1-47.
- GREEN, J. A. 1955. Hormone secretion by the immature mouse ovary after gonadotrophic stimulation. *Endocrinology*, **56**, 621-627.
- GREEN, J. A. 1956. Functional responses of the immature mouse ovary to different levels of equine pituitary gonadotrophin. *Anat. Rec.*, **126**, 195-211.
- GREEN, J. A. 1957. Response of the mouse ovary to gonadotrophin administered at various ages (Abstr.). *Proc. Am. A. Anat.*, *Anat. Rec.*, **127**, 297.
- GREEN, S. H., AND ZUCKERMAN, S. 1951. The number of oocytes in the mature rhesus monkey (*Macaca mulatta*). *J. Endocrinol.*, **7**, 194-202.
- GREENE, R. R., AND BURRILL, M. W. 1939. Androgenic function of APL stimulated ovaries in immature rats. *Proc. Soc. Exper. Biol. & Med.*, **42**, 761-764.
- GREE, M. A. 1952. The role of the hypothalamus in the control of thyroid function. *J. Clin. Endocrinol.*, **12**, 1259-1268.
- GUYENOT, E., AND NAVILLE-TROLLET, I. 1936. Masculinisation provoquée de femelles de cobayes. *Rev. Suisse Zool.*, **43**, 415-451.
- HAFEZ, E. S. E. 1954. Oestrus and some related phenomena in the buffalo. *J. Agric. Sc.*, **44**, 165-172.
- HAIN, A. 1935. The effect (a) of litter size on growth and (b) of oestrone administered during lactation (rat). *Quart. J. Exper. Physiol.*, **25**, 303-313.
- HAMMOND, J. 1927. *The Physiology of Reproduction in the Cow*, pp. 226. Cambridge: Cambridge University Press.
- HAMMOND, J., AND MARSHALL, F. H. A. 1925. *Reproduction in the Rabbit*. Edinburgh: Oliver & Boyd, Ltd.
- HAMMOND, J., AND WODZICKI, K. 1941. Anatomical and histological changes during the oestrous cycle in the mare. *Proc. Roy. Soc. London*, ser. B, **130**, 1-23.
- HAMMOND, J., JR. 1956. The rabbit corpus luteum: oestrogen prolongation and the accompanying changes in the genitalia. *Acta endocrinol.*, **21**, 307-320.
- HAMMOND, J., JR., AND ROBSON, J. M. 1951. Local maintenance of the rabbit corpus luteum with oestrogen. *Endocrinology*, **49**, 381-389.
- HARMAN, M. T., AND KRIGAS, H. D. 1938. The development and atresia of the Graafian follicle and the division of the intra-ovarian ova in the guinea pig. *Am. J. Anat.*, **63**, 79-99.
- HARRISON, R. J. 1946. The early development of the corpus luteum in the mare. *J. Anat.*, **80**, 160-166.
- HARRISON, R. J. 1948a. The development and fate of the corpus luteum in the vertebrate series. *Biol. Revs.*, **23**, 296-331.
- HARRISON, R. J. 1948b. The changes occurring in the ovary of the goat during the oestrous cycle and in early pregnancy. *J. Anat.*, **82**, 21-48.
- HARTER, B. T. 1948. Glycogen and carbohydrate-protein complexes in the ovary of the white rat during the oestrous cycle. *Anat. Rec.*, **102**, 349-367.
- HARTMAN, C. G. 1932. Studies in the reproduction of the monkey, *Macacus (Pithecius) rhesus*, with special reference to menstruation and pregnancy. *Contr. Embryol.*, Carnegie Inst. Washington, **24**, 1-161.
- HARTMAN, C. G. 1936. *Time of Ovulation in Women: A Study on the Fertile Period in the Menstrual Cycle*. Baltimore: The Williams & Wilkins Company.
- HASKINS, A. L. 1950. Assay of circulating progesterone by ultraviolet spectroscopy. *Proc. Soc. Exper. Biol. & Med.*, **73**, 439-443.
- HASLEWOOD, G. A. D. 1950. Chemical assay of estrogens and progesterone. In *Hormone Assay*, C. W. Emmens, Ed., pp. 443-487. New York: Academic Press, Inc.
- HEINEMANN, M., JOHNSON, C. E., AND MAX, E. B. 1948. The serum precipitable iodine in pregnancy. *J. Clin. Invest.*, **27**, 91-97.
- HERNANDEZ, T. 1943. Hormonal ambisexuality of ovarian grafts in female rats. *Am. J. Anat.*, **73**, 127-152.
- HILL, R. T. 1937a. Ovaries secrete male hormone. I. Restoration of the castrate type of seminal vesicles and prostate glands to normal by grafts of ovaries in mice. *Endocrinology*, **21**, 495-502.
- HILL, R. T. 1937b. Ovaries secrete male hormone. III. Temperature control of male hormone output by grafted ovaries. *Endocrinology*, **21**, 633-636.
- HILL, R. T., ALLEN, E., AND KRAMER, T. C. 1935. Cinemicrographic studies of rabbit ovulation. *Anat. Rec.*, **63**, 239-245.
- HISAW, F. L. 1944. The placental gonadotrophin and luteal function in monkeys (*Macaca mulatta*). *Yale J. Biol. & Med.*, **17**, 119-137.
- HISAW, F. L. 1947. Development of the Graafian follicle and ovulation. *Physiol. Rev.*, **27**, 95-119.
- HISAW, F. L., AND ZARROW, M. X. 1950. The physiology of relaxin. *Vitamins & Hormones*, **8**, 151-178.
- HISAW, F. L., AND VELARDO, J. T. 1951. Inhibi-

- of progesterone in decidual development by steroid compounds. *Endocrinology*, **49**, 732-741.
- HISAV, F. L., JR. 1959. Comparative effectiveness of estrogens on fluid imbibition and growth of the rat's uterus. *Endocrinology*, **64**, 276-289.
- HOAR, R. M., GOY, R. W., AND YOUNG, W. C. 1957. Loci of action of the thyroid hormone on reproduction in the female guinea pig. *Endocrinology*, **60**, 337-346.
- HÖHN, E. O., AND ROBSON, J. M. 1949. Mode of action of oestrogens on the corpus luteum. *Endocrinology*, **44**, 536-541.
- HOOVER, C. W., AND FORBES, T. R. 1947. A bioassay for minute amounts of progesterone. *Endocrinology*, **41**, 158-169.
- HUMPHREYS, E. M., AND ZUCKERMAN, S. 1954. Unilateral ovariectomy after x-irradiation of the ovaries. *J. Endocrinol.*, **10**, 155-166.
- HUSEBY, R. A., SAMUELS, L. T., AND HELMREICH, M. L. 1954. Steroid-3B-OL dehydrogenase activity and androgen production in adrenal and interstitial-cell tumors of mice. *Proc. Soc. Exper. Biol. & Med.*, **86**, 580-586.
- INGRAM, D. L. 1953. The effect of hypophysectomy on the number of oocytes in the adult albino rat. *J. Endocrinol.*, **9**, 307-311.
- INGRAM, D. L. 1957. Grafts of ovarian medullary tissue in the rabbit. *J. Endocrinol.*, **14**, 355-360.
- INGRAM, D. L. 1959. The effect of oestrogen on the atresia of ovarian follicles. *J. Endocrinol.*, **19**, 123-125.
- INGRAM, D. L., MANDEL, A. M., AND ZUCKERMAN, S. 1958. The influence of age on litter-size. *J. Endocrinol.*, **17**, 280-285.
- JANES, R. G. 1954. Effect of a pituitary gonadotrophin on the ovaries of hypothyroid rats. *Endocrinology*, **54**, 464-470.
- JANES, R. G., AND BRADBURY, J. T. 1952. Ovarian retention cysts in hypothyroid rats treated with diethylstilbestrol. *Proc. Soc. Exper. Biol. & Med.*, **79**, 187-188.
- JEFFERIES, W. MCK. 1960. Small doses of cortisone and related steroids in infertility associated with ovarian dysfunction. *Fertil. & Steril.*, **11**, 100-108.
- JEFFERIES, W. MCK., WEHR, W. C., WEHR, D. R., AND PROUTY, R. L. 1958. The use of cortisone and related steroids in infertility. *Fertil. & Steril.*, **9**, 145-166.
- JENSEN, C. E., AND ZACHARIAE, F. 1958. Studies on the mechanism of ovulation. Isolation and analysis of acid mucopolysaccharides in bovine follicular fluid. *Acta endocrinol.*, **27**, 356-368.
- JOHNSON, D. C. 1958. Ovarian androgens in parabiotic rats. *Endocrinology*, **62**, 340-347.
- JONES, G. E. S., HOWARD, J. E., AND LANGFORD, H. 1953. The use of cortisone in follicular phase disturbances. *Fertil. & Steril.*, **4**, 49-62.
- KAHN, L. C., AND DOISY, E. A. 1928. The vaginal smear method of assay of the ovarian hormone. *Endocrinology*, **12**, 760-772.
- KAR, A. B., AND SUR, R. N. 1953. The effect of testosterone propionate on the formation of ovarian cysts in experimental hypothyroid rats. *Acta endocrinol.*, **13**, 173-176.
- KATSI, S. 1950. The androgenic activity of ovarian transplants to the seminal vesicle of the castrated adult male rat. *Endocrinology*, **47**, 370-383.
- KAUFMANN, C. 1952. Corpus luteum. *Arch. Gynäk.*, **183**, 264-275.
- KAWAKAMI, M., AND SAWYER, C. H. 1959. Neuroendocrine correlates of changes in brain activity thresholds by sex steroids and pituitary hormones. *Endocrinology*, **65**, 652-668.
- KELLEY, K. 1942. Sterility in the female with special reference to psychic factors. I. A review of the literature. *Psychosom. Med.*, **4**, 211-222.
- KELLEY, K., DANIELS, G. E., POE, J., EASSER, R., AND MONROE, R. 1954. Psychological correlations with secondary amenorrhea. *Psychosom. Med.*, **16**, 129-147.
- KNAUS, H. 1935. *Die periodische Fruchtbarkeit und Unfruchtbarkeit des Weibes*. Wien: Wilhelm Mauddrich Verlag.
- KNIGGE, K. M., AND LEATHEM, J. H. 1956. Growth and atresia of follicles in the ovary of the hamster. *Anat. Rec.*, **124**, 679-707.
- KOLMER, W. 1918. Zur vergleichenden Histologie, Zytologie und Entwicklungs-geschichte der Säugereibenniere. *Arch. mikroskop. Anat.*, **91**, 1-139.
- KOSTITCH, A., AND TÉLÉBAKOVITCH, A. 1929. Sur un rythme vaginal chez les animaux ovarioctomisés. *Compt. rend. Soc. biol.*, **100**, 51-54.
- KROGER, W. S., AND FREED, S. C. 1950. Psychosomatic factors in functional amenorrhea. *Am. J. Obst. & Gynec.*, **59**, 328-336.
- KUPPERMAN, H. S., MCSHAN, W. H., AND MEYER, R. K. 1948. Gonadotrophic hormones and ovarian hyperemia in the rat. *Endocrinology*, **43**, 275-282.
- KUPPERMAN, H. S., EPSTEIN, J. A., BLATT, M. H. G., AND STONE, A. 1958. Induction of ovulation in the human: Therapeutic and diagnostic importance. *Am. J. Obst. & Gynec.*, **75**, 301-309.
- LEVER, J. D. 1956. Remarks on the electron microscopy of the rat luteum and comparison with earlier observations on the adrenal cortex. *Anat. Rec.*, **124**, 111-125.
- LEVIN, L., AND JÄHLER, J. W. 1948. The effect of induced secretory activity on the cholesterol content of the immature rat ovary. *Endocrinology*, **43**, 154-166.
- LIENHART, R. 1940. A propos de la durée de la gestation chez le Lièvre. *Compt. rend. Soc. biol.*, **133**, 133-135.
- LISSER, H., AND TRAUT, H. F. 1954. The Stein-Leventhal syndrome with report of a verified case. *Am. Pract. & Digest Treat.*, **5**, 968-972.
- LOEB, L. 1918. Aging processes in the ovaries of mice belonging to strains differing in the incidence of mammary carcinoma. *Arch. Path.*, **46**, 401-410.
- LONG, R. C., AND BRADBURY, J. T. 1951. Induction and maintenance of decidual changes with progesterone and estrogen. *J. Clin. Endocrinol.*, **14**, 131-145.

- LORRAINE, J. A. 1958. *The Clinical Application of Hormone Assay*. Baltimore: The Williams & Wilkins Company.
- LYONS, W. R., AND TEMPLETON, H. J. 1936. Intra-vaginal assay of urinary estrin. *Proc. Soc. Exper. Biol. & Med.*, **33**, 587-589.
- MACCORQUODALE, D. W., THAYER, S. A., AND DOISY, E. A. 1936. The isolation of the principal estrogenic substance of liquor folliculi. *J. Biol. Chem.*, **115**, 435-448.
- MAENGWYN-DAVIES, G. D., AND WEINER, R. 1955. Excretion of 17-hydroxycorticosteroids during the menstrual cycle. *J. Clin. Endocrinol.*, **15**, 1150-1151.
- MAKEPEACE, A. W., WEINSTEIN, G. L., AND FRIEDMAN, M. N. 1938. Effect of coitus on gonadotropic content of pituitary glands of pseudopregnant rabbits. *Endocrinology*, **22**, 667-668.
- MANDL, A. M. 1951. Cyclical changes in the vaginal smear of adult ovariectomized rats. *J. Exper. Biol.*, **28**, 585-592.
- MANDL, A. M., AND ZUCKERMAN, S. 1950. The numbers of normal and atretic ova in the mature rat. *J. Endocrinol.*, **6**, 426-435.
- MANDL, A. M., AND ZUCKERMAN, S. 1951a. The effect of destruction of the germinal epithelium on the numbers of oocytes. *J. Endocrinol.*, **7**, 103-111.
- MANDL, A. M., AND ZUCKERMAN, S. 1951b. Numbers of normal id and atretic oocytes in unilaterally spayed rats. *J. Endocrinol.*, **7**, 112-119.
- MANDL, A. M., AND ZUCKERMAN, S. 1951c. The relation of age to the number of oocytes. *J. Endocrinol.*, **7**, 190-193.
- MANDL, A. M., AND ZUCKERMAN, S. 1951d. Changes in ovarian structure following the injection of carbonic acid into the ovarian bursa. *J. Endocrinol.*, **7**, 227-234.
- MANDL, A. M., AND ZUCKERMAN, S. 1952a. The growth of the oocyte and follicle in the adult rat. *J. Endocrinol.*, **8**, 126-132.
- MANDL, A. M., AND ZUCKERMAN, S. 1952b. The number of oocytes in ovarian fragments after compensatory hypertrophy. *J. Endocrinol.*, **8**, 347-356.
- MANDL, A. M., AND ZUCKERMAN, S. 1956a. The reactivity of the x-irradiated ovary of the rat. *J. Endocrinol.*, **13**, 243-261.
- MANDL, A. M., AND ZUCKERMAN, S. 1956b. Changes in the mouse after x-ray sterilization. *J. Endocrinol.*, **13**, 262-268.
- MARDEN, W. G. R. 1952. The hormone control of ovulation in the calf. *Endocrinology*, **50**, 456-461.
- MARINE, D. 1935. The physiology and principal interrelations of the thyroid. In *Glandular Physiology and Therapy*, pp. 315-333. Chicago: American Medical Association.
- MARKEE, J. E., AND HINSEY, J. C. 1936. Observations on ovulation in the rabbit. *Anat. Rec.*, **64**, 309-319.
- MARTIN, L., AND CLARINGBOLD, P. J. 1958. A highly sensitive assay for oestrogens. *Nature, London*, **181**, 620-621.
- MARX, L., AND BRADBURY, J. T. 1940. Correlation of ovarian histology and intersexuality of the genital apparatus with special reference to APL-treated infantile rats. *Anat. Rec.*, **78**, 79-103.
- MARX, R. 1935. Influence of hysterectomy on endocrine balance. *Am. J. Surg.*, **23**, 117-121.
- MATTHEWS, L. H. 1911. Notes on the genitalia and reproduction of some African bats. *Proc. Zool. Soc., London, ser. B*, **111**, 289-346.
- MCGINTY, D. A., ANDERSON, L. P., AND MCCULLOUGH, N. B. 1939. Effect of local application of progesterone on the rabbit uterus. *Endocrinology*, **24**, 829-832.
- McKAY, D. C., AND ROBINSON, D. 1947. Observations on the fluorescence, birefringence and histochemistry of the human ovary during the menstrual cycle. *Endocrinology*, **41**, 378-394.
- McKENZIE, F. F. 1926. The normal oestrous cycle in the sow. *Univ. Missouri Agric. Exper. Sta. Bull.*, **86**.
- McKEOWN, T., GIBSON, J. R., AND DOUGRAY, T. 1954. A study of variation in the length of the menstrual cycle. *J. Obst. Gynaec. Brit. Emp.*, **61**, 678-682.
- MERRILL, R. C. 1958. Estriol: a review. *Physiol. Rev.*, **38**, 463-480.
- MEYER, R. K., AND McSHAN, W. H. 1950. Enzymes in the ovarian tissues of rats. In *Menstruation and Its Disorders*, E. T. Engle, Ed., pp. 62-92. Springfield, Ill.: Charles C Thomas.
- MILLER, D. C., AND EVERETT, J. W. 1948. Ascorbic acid concentration and cholesterol storage in the corpus luteum of the pregnant rat under experimental conditions. *Endocrinology*, **42**, 421-423.
- MONEY, W. L., KRANTZ, L., FAGER, J., KIRSCHNER, L., AND RAWSON, R. W. 1951. The effects of various steroids on the collection of radioactive iodine by the thyroid gland of the rat. *Endocrinology*, **48**, 682-690.
- MOORE, C. R., AND PRICE, D. 1932. Gonad hormone functions and the reciprocal influence between gonads and hypophysis. *Am. J. Anat.*, **50**, 13-72.
- MOORE, C. R., AND MORGAN, C. F. 1943. First response of developing opossum gonads to equine gonadotropic treatment. *Endocrinology*, **32**, 17-26.
- MOORE, W. W., AND NALBANDOV, A. V. 1955. Maintenance of the corpora lutea in sheep with luteogenic hormone. *J. Endocrinol.*, **13**, 18-25.
- MORGAN, C. F. 1946. Sexual rhythms in the reproductive tract of the adult female opossum and effects of hormonal treatments. *Am. J. Anat.*, **78**, 411-463.
- MORICARD, R., AND GOTHÉ, S. 1953. Hormonal mechanism of the first polar body formation in the follicle. In *Mammalian Germ Cells*, G. E. W. Wolstenholme, Ed., pp. 180-186. Ciba Foundation Symposium. Boston: Little, Brown & Company.
- MORRIS, J. McL., AND SCULLY, R. E. 1958. *Endocrine Pathology of the Ovary*. St. Louis: C. Mosby Company.
- MOSS, S., WRENN, T. R., AND SYKES, J. F.

- Some histological and histochemical observations on the bovine ovary during the estrous cycle. *Anat. Rec.*, **120**, 409-433.
- MOSS-SMAY, H. W. 1937. The thecal gland and its relation to the reproductive cycle. *Am. J. Anat.*, **61**, 289-319.
- MYERS, H. I., YOUNG, W. C., AND DEMPSEY, E. W. 1936. Graafian follicle development throughout the reproductive cycle in the guinea pig, with special reference to changes during oestrus (sexual receptivity). *Anat. Rec.*, **65**, 381-401.
- NALBANDOV, A. V., MOORE, W. W., AND NORTON, H. W. 1955. Further studies on the neurogenic control of the estrous cycle by uterine distention. *Endocrinology*, **56**, 225-231.
- NEHER, G. M., AND ZARROW, M. X. 1954. Concentration of progesterin in the serum of the non-pregnant, pregnant and post-partum ewe. *J. Endocrinol.*, **11**, 323-330.
- NELSON, W. O. 1929. Oestrus during pregnancy. *Science*, **70**, 453-454.
- NEUMANN, H. O. 1937. Klinische und pathologisch-anatomische Studie zum Problem Schilddrüsen-Unterfunktion und weibliche Geschlechtsfunktion. *Arch. Gynäk.*, **163**, 406-438.
- NISHIZUKA, Y. 1954. Histological studies on ovaries: mainly histochemical observations on the ovarian endocrine functions. *Acta. scholae med. Univ. Kyoto*, **31**, 215-257.
- NOACH, E. L. 1955a. Influence of oestrogens on thyroid function. I. *Acta endocrinol.*, **19**, 127-138.
- NOACH, E. L. 1955b. Influence of oestrogens on thyroid function. II. *Acta endocrinol.*, **19**, 139-151.
- NOACH, E. L., AND VAN REES, G. P. 1958. Ascorbic acid in the gonads of rats. *Acta endocrinol.*, **27**, 502-508.
- NOBLE, R. L., ROWLANDS, I. W., WARWICK, M. H., AND WILLIAMS, P. C. 1939. Comparative effects of certain gonadotrophic extracts on the ovaries of normal and hypophysectomized rats. *J. Endocrinol.*, **1**, 22-35.
- OBER, K. G., AND WEBER, M. 1951. Beitrag zur Progesteronwirkung. *Klin. Wchenschr.*, **29**, 53-55.
- ODEBLAD, E. 1954. Studies on the physiology of the follicular fluid. *Acta endocrinol.*, **15**, 313-316.
- ODEBLAD, E., NATL, G., SELIN, B., AND WESTIN, B. 1956. Some effects of gonadotrophic hormones on the ovarian circulation in the rabbit. *Acta endocrinol.*, **22**, 65-67.
- ODOR, D. L. 1959. Electron microscopic observations on developing ovarian and unfertilized tubal ova of the rat (Abstr.). *Proc. Am. A. Anat.*, *Anat. Rec.*, **133**, 453.
- ODOR, D. L. 1960. Electron microscopic studies on ovarian oocytes and unfertilized tubal ova in the rat. *J. Biophys. & Biochem. Cytol.*, **7**, 567-574.
- ODOR, D. L., AND RENNINGER, D. F. 1960. Polar body formation in the rat oocyte as observed with the electron microscope. *Anat. Rec.*, **137**, 13-24.
- ORTIZ, E. 1947. The postnatal development of the reproductive system of the golden hamster (*Cricetus auratus*) and its reactivity to hormones. *Physiol. Zool.*, **20**, 45-67.
- ORTIZ, E. 1955. The relationship of advancing age to the reactivity of the reproductive system in the female hamster. *Anat. Rec.*, **122**, 517-537.
- PAESI, F. J. A. 1949a. The relation between the rate of growth of the ovarian follicles and the shape of the frequency curve representing their variability in size. *Acta endocrinol.*, **3**, 173-180.
- PAESI, F. J. A. 1949b. The influence of hypophysectomy and of subsequent treatment with chorionic gonadotrophin on follicles of different size in the ovary of the rat. *Acta endocrinol.*, **3**, 89-104.
- PAESI, F. J. A. 1952. The effect of small doses of oestrogen on the ovary of the immature rat. *Acta endocrinol.*, **11**, 251-268.
- PARKES, A. S. 1926a. Observations on the oestrous cycle of the albino mouse. *Proc. Roy. Soc. London, ser. B*, **100**, 151-170.
- PARKES, A. S. 1926b. On the occurrence of the oestrous cycle after x-ray sterilization. I. Irradiation of mice at three weeks old. *Proc. Roy. Soc. London, ser. B*, **100**, 172-199.
- PARKES, A. S. 1927a. On the occurrence of the oestrous cycle after x-ray sterilization. II. Irradiation at or before birth. *Proc. Roy. Soc. London, ser. B*, **101**, 71-95.
- PARKES, A. S. 1927b. On the occurrence of the oestrous cycle after x-ray sterilization. III. The periodicity of oestrus after sterilization of the adult. *Proc. Roy. Soc. London, ser. B*, **101**, 421-449.
- PARKES, A. S. 1943. Induction of superovulation and superfecundation in rabbits. *J. Endocrinol.*, **3**, 268-279.
- PARKES, A. S. 1945. The adrenal-gonad relationship. *Physiol. Rev.*, **25**, 203-254.
- PARKES, A. S. 1950. Androgenic activity of the ovary. *Recent Progr. Hormone Res.*, **5**, 101-114.
- PARROTT, M. W., JOHNSTON, M. E., AND DURBIN, P. W. 1960. The effects of thyroid and parathyroid deficiency on reproduction in the rat. *Endocrinology*, **67**, 467-483.
- PASCHKIS, K. E., CANTAROW, A., AND PEACOCK, W. C. 1948. The influence of estrogens on thyroid function as measured by uptake of radioactive iodine. *Proc. Soc. Exper. Biol. & Med.*, **68**, 485-486.
- PASCHKIS, K. E., AND RAKOFF, A. E. 1950. Some aspects of the physiology of estrogenic hormones. *Recent Progr. Hormone Res.*, **5**, 115-150.
- PAYNE, R. W. 1951. Relationship of pituitary and adrenal cortex to ovarian hyperemia reaction in the rat. *Proc. Soc. Exper. Biol. & Med.*, **77**, 212-214.
- PAYNE, R. W., AND HELBAUM, A. A. 1955. The effect of estrogens on the ovary of the hypophysectomized rat. *Endocrinology*, **57**, 193-199.
- PAYNE, R. W., HELBAUM, A. A., AND OWENS, J. N., JR. 1956. The effect of androgens on the



- ovaries and uterus of the estrogen-treated hypophysectomized immature rat. *Endocrinology*, **59**, 306-316.
- PAYNE, R. W., AND RUNSER, R. H. 1958. The influence of estrogen and androgen on the ovarian response of hypophysectomized immature rats to gonadotropins. *Endocrinology*, **62**, 313-321.
- PEARLMAN, W. H. 1957. Circulating steroid hormone levels in relation to steroid hormone production. Ciba Foundation Colloquia *Endocrinol.*, **11**, 233-251.
- PECZENIK, O. 1942. Actions of sex hormones on oestrous cycle and reproduction of the golden hamster. *J. Endocrinol.*, **3**, 157-167.
- PENCHARZ, R. I. 1940. Effect of estrogens and androgens alone and in combination with chorionic gonadotropin on the ovary of the hypophysectomized rat. *Science*, **91**, 554-555.
- PERRY, J. S. 1953. The reproduction of the African elephant, *Loxodonta africana*. Tr. Roy. Soc., London, ser. B. *Biol. Sc.*, **237**, 93-149.
- PERRY, J. S. 1954. Fecundity and embryonic mortality in pigs. *J. Embryol. & Exper. Morphol.*, **2**, 308-322.
- PERRY, J. S., AND POMEROY, R. W. 1956. Abnormalities of the reproductive tract of the sow. *J. Agric. Sc.*, **47**, 238-248.
- PETERSON, R. R., WEBSTER, R. C., RAYNER, B., AND YOUNG, W. C. 1952. The thyroid and reproductive performance in the adult female guinea pig. *Endocrinology*, **51**, 504-518.
- PFEIFFER, C. A., AND HOOKER, C. W. 1942. Experiments on the source of ovarian androgen in the mouse. *Anat. Rec.*, **83**, 543-571.
- PHOENIX, C. H., GOY, R. W., GERRALL, A. A., AND YOUNG, W. C. 1959. Organizing action of prenatally administered testosterone propionate on the tissues mediating mating behavior in the female guinea pig. *Endocrinology*, **65**, 369-382.
- PLATE, W. P. 1957. An ovarian interstitial-cell tumour with oestrogenic function. *Acta endocrinol.*, **26**, 489-498.
- PLOTZ, E. J., AND DAVIS, M. E. 1957. Distribution of radioactivity in human maternal and fetal tissues following administration of  $C^{14}$ -progesterone. *Proc. Soc. Exper. Biol. & Med.*, **95**, 92-96.
- POCHIN, E. E. 1952. The iodine uptake of the human thyroid throughout the menstrual cycle and in pregnancy. *Clin. Sc.*, **11**, 441-445.
- PRICE, D. 1944. The reactivity of the prostate gland of the female rat in relation to age. *Am. J. Anat.*, **75**, 207-231.
- PRICE, D., AND ORTIZ, E. 1944. The relation of age to reactivity in the reproductive system of the rat. *Endocrinology*, **34**, 215-239.
- RAKOFF, A. E., AND CANTAROW, A. 1950. Estrogen content of blood of ovarian vein of the dog and spermatic vein of the stallion. *Fed. Proc.*, **9**, 103.
- RAKOFF, A. E., CANTAROW, A., PASCHKIS, K. E., HANSEN, L. P., AND WALKLING, A. A. 1944. Removal of exogenous estrogens from the circulation. *Endocrinology*, **34**, 370-375.
- RAKOFF, A. E., PASCHKIS, K. E., AND CANTAROW, A. 1943. Conjugated estrogens in human pregnancy serum. *Am. J. Obst. & Gynec.*, **46**, 856-860.
- RANDALL, L. M., AND McELIN, T. W. 1951. *Amenorrhoea*. Springfield, Ill.: Charles C Thomas.
- RAPPAPORT, W. J., GOLDSTEIN, B., AND HASKINS, A. L. 1957. Intravenous progesterone. Basic effects in rabbits. *Obst. & Gynec.*, **9**, 497-504.
- REECE, R. P., AND TURNER, C. W. 1937. Experimentally altering galactin content of the rat pituitary. *Proc. Soc. Exper. Biol. & Med.*, **36**, 283-285.
- RENNELS, E. G. 1951. Influence of hormones on the histochemistry of ovarian interstitial tissue in the immature rat. *Am. J. Anat.*, **88**, 63-107.
- REYNOLDS, S. R. M., AND GINSBURG, N. 1942. Microdetermination of  $\Delta^4$ -3 ketosteroid (progesterone) obtained from small volumes of serum. *Endocrinology*, **31**, 147-161.
- RIEDEL, I. L., AND McCELLER, G. C. 1954. Formation of a protein-bound metabolite of estradiol- $16-C^{14}$  by rat liver homogenates. *J. Biol. Chem.*, **210**, 249-257.
- RISMAN, G. C. 1946. Experimental stimulation of the female reproductive tract in the opossum (*Didelphys virginiana*) (Abst.). *Proc. Am. Soc. Zool., Anat. Rec.*, **94**, 408.
- ROBERTS, S., AND SZEGO, C. M. 1946. The nature of circulating estrogen: lipoprotein-bound estrogen in human plasma. *Endocrinology*, **39**, 183-187.
- ROBERTS, S., AND SZEGO, C. M. 1947. The early reduction in uterine response to alpha-estradiol in the partially hepatectomized rat, and the subsequent enhancement during active liver regeneration. *Endocrinology*, **40**, 73-85.
- ROBERTS, S., AND SZEGO, C. M. 1953. Steroid interaction in the metabolism of reproductive target organs. *Physiol. Rev.*, **33**, 593-629.
- ROBINSON, T. J. 1951. The production of coincident oestrus and ovulation in the anoestrous ewe with progesterone and pregnant mare serum. *J. Endocrinol.*, **10**, 117-124.
- ROCK, J., GARCIA, C. R., AND PINCUS, G. 1956. Synthetic progestins in the normal human menstrual cycle. *Recent Progr. Hormone Res.*, **13**, 323-346.
- ROCKENSCHAU, A. 1951. Die Eigenfluoreszenz in Follikeln und Gelbkörpern. *Zentralbl. Gynäk.*, **73**, 1206-1212.
- ROSSMAN, I., AND BARTELMIEZ, G. W. 1946. Delayed ovulation, a significant factor in the variability of the menstrual cycle. *Am. J. Obst. & Gynec.*, **52**, 28-33.
- ROWLANDS, I. W. 1944. The production of ovulation in the immature rat. *J. Endocrinol.*, **3**, 384-391.
- ROWLANDS, I. W. 1949. Serum gonadotrophin and ovarian activity in the pregnant mare. *J. Endocrinol.*, **6**, 184-191.
- ROWLANDS, I. W. 1956. The corpus luteum of the guinea pig. Ciba Foundation Colloquia *Ageing*, **2**, 69-85.
- ROWLANDS, I. W., AND WILLIAMS, P. C. 1943. The

- (doses) of ovulation in hypophysectomized rats. *J. Endocrinol.*, **3**, 310-315.
- ROBINSTEIN, B. B. 1939. Functional sterility in women. *Ohio State M. J.*, **35**, 1066-1068.
- ROBINSTEIN, H. S., AMBANEL, A. R., AND NADER, D. N. 1938. Influence of testosterone propionate on vaginal opening in the immature albino rat. *Proc. Soc. Exper. Biol. & Med.*, **39**, 20-22.
- SAMUELS, L. T., AND HELMBREICH, M. L. 1956. The influence of chorionic gonadotropin on the  $\beta$ - $\beta$ -dehydrogenase activity of testes and adrenals. *Endocrinology*, **58**, 435-442.
- SAMUELS, L. T., HELMBREICH, M. L., LASATER, M. B., AND REICH, H. 1951. An enzyme in endocrine tissues which oxidizes  $\Delta^5$ -3 hydroxy steroids to a, b unsaturated ketones. *Science*, **113**, 490-491.
- SANDBERG, A. A., SLACNWHITE, W. R., AND ANTONIADIS, H. N. 1957. The binding of steroids and steroid conjugates to human plasma proteins. *Recent Progr. Hormone Res.*, **13**, 209-267.
- SCHMIDT, I. G. 1936. The excretion of theelin in the urine of guinea pigs with irradiated ovaries. *Anat. Rec.*, **64**, 255-266.
- SCHWARTZ, C. W. 1942. Breeding season of the cotton tail in central Missouri. *J. Mammal.*, **23**, 1-16.
- SELYE, H., COLLIP, J. B., AND THOMSON, D. L. 1935. The age factor in responsiveness to gonadotropic hormones. *Proc. Soc. Exper. Biol. & Med.*, **32**, 800-803.
- SEVITT, S. 1946. Early ovulation. *Lancet*, **2**, 448-450.
- SHARMAN, A. 1950. The re-establishment of ovulation, post-partum and post-abortion. *Proc. Soc. Study Fertil.*, No. 1, 26-31.
- SHARMAN, A. 1951. Menstruation after childbirth. *J. Obst. & Gynaec. Brit. Emp.*, **58**, 440-445.
- SHERMAN, A. L., AND WOLF, R. B. 1959. An endocrine basis for endometrial carcinoma. *Am. J. Obst. & Gynec.*, **77**, 233-242.
- SHUPPEL, S. 1950. The ovarian theca cell. *J. Obst. & Gynaec. Brit. Emp.*, **57**, 362-387.
- SHORT, R. V. 1958. Progesterone in blood. I. The chemical determination of progesterone in peripheral blood. *J. Endocrinol.*, **16**, 415-425.
- SHORT, R. V. 1960. Blood progesterone levels in relation to parturition. *J. Reprod. & Fertil.*, **1**, 61-70.
- SIMPSON, M. E., EVANS, H. M., FRAENKEL-COENRAT, H. L., AND LI, C. H. 1941. Synthesis of estrogens with pituitary gonadotrophins in hypophysectomized rats. *Endocrinology*, **28**, 37-41.
- SLACNWHITE, W. R., JR., AND SAMUELS, L. T. 1956. Progesterone as a precursor of testicular androgens. *J. Biol. Chem.*, **220**, 341-352.
- SLACNWHITE, W. R., JR., AND SANDBERG, A. A. 1958. The binding of urinary conjugated steroids to serum albumin: a new method of extraction. *Endocrinology*, **62**, 283-286.
- SLACNWHITE, W. R., JR., AND SANDBERG, A. A. 1959. Transcortin: a corticosteroid-binding protein of plasma. *J. Clin. Invest.*, **38**, 384-391.
- SMITH, E. K. 1955. Interrelationships of anterior pituitary and adrenal cortex in the rat ovary hypohyemia reaction. *Endocrinology*, **56**, 567-574.
- SMITH, O. W. 1960. Estrogens in the ovarian fluids of normally menstruating women. *Endocrinology*, **67**, 698-707.
- SMITH, P. E., AND ENGLE, E. T. 1927. Experimental evidence regarding the role of the anterior pituitary in the development and regulation of the genital system. *Am. J. Anat.*, **40**, 159-217.
- SNEIDER, M. D. 1940. Rhythms of oogenesis before sexual maturity in the rat and cat. *Am. J. Anat.*, **67**, 471-499.
- SNEEL, G. D., FEKETE, E., HUMMEL, K. P., AND LAW, L. W. 1940. The relation of mating, ovulation and the estrous smear in the house mouse to time of day. *Anat. Rec.*, **76**, 39-54.
- SOLIMAN, F. A., AND REINKE, E. P. 1954. Changes in uptake of radioactive iodine by the thyroid of the rat during the estrous cycle. *Am. J. Physiol.*, **178**, 89-90.
- SOLIMAN, F. A., AND BABAWI, H. M. 1956. Levels of thyroid and thyrotrophic hormones in the blood of rats at various stages of the oestrous cycle. *Nature, London*, **177**, 235.
- SOLIMSEN, U. V. 1945. Synthetic estrogens and the relation between their structure and their activity. *Chem. Rev.*, **37**, 481-598.
- SOMMERVILLE, I. F., AND DESHPANDE, G. N. 1958. The quantitative determination of progesterone and pregnandiol in human plasma. *J. Clin. Endocrinol.*, **18**, 1223-1236.
- ST. WHITELOCK, O. V. 1958. New steroid compounds with progestational activity. *Ann. New York Acad. Sc.*, **71**, 479-806.
- STEIN, K. F., AND ALLEN, E. 1942. Attempts to stimulate proliferation of the germinal epithelium of the ovary. *Anat. Rec.*, **82**, 1-9.
- STIEVE, H. 1952. *Cycelus. Physiologie und Pathologie (Anatomie)*. Arch. Gynäk., **183**, 178-203.
- STODDARD, F. J., ENGSTROM, W. W., HOVIS, W. F., SERVIS, L. T., AND WATTS, A. D. 1957. Effect in women of bilateral oophorectomy on circulating thyroid hormone. *J. Clin. Endocrinol.*, **17**, 561-564.
- STONE, M. L. 1959. Effects of relaxin in the human. In *Recent Progress in Endocrinology of Reproduction*, pp. 429-439. New York: Academic Press, Inc.
- STUBBS, S. H., AND POLITOU, V. C. 1951. Intravenous assay of preparations causing ovarian hyperemia in the immature rat. *Endocrinology*, **48**, 435-442.
- SVENDSEN, R. 1960. A double isotopic derivative method for the quantitative determination of oestrone and 17 $\beta$ -oestradiol in plasma. *Acta endocrinol.*, **35**, 161-187.
- SWANN, R. O., AND SCHUMACHER, G. F. 1958. Relaxin; its use in normal obstetrics. *J. Iowa State M. A.*, **48**, 599-601.
- SWEZY, O., AND EVANS, H. M. 1930. Ovarian

- changes during pregnancy in the rat. *Science*, **71**, 46.
- SZEGO, C. M. 1953. The influence of the liver upon estrogen-protein binding *in vitro*. *Endocrinology*, **52**, 669-678.
- SZEGO, C. M. 1957. Steroid interaction in the *in vitro* biosynthesis of steroid-protein complexes. *Ciba Foundation Colloquia Endocrinol.*, **11**, 286-308.
- SZEGO, C. M., AND ROBERTS, S. 1946. The nature of circulating estrogen. *Proc. Soc. Exper. Biol. & Med.*, **61**, 161-164.
- TALBERT, G. B., MEYER, R. K., AND MCSHANE, W. H. 1951. Effect of hypophysectomy at the beginning of proestrus on maturing follicles in the ovary of the rat. *Endocrinology*, **49**, 687-694.
- TALMADGE, R. V., BUCHANAN, G. D., KRAINTZ, F. W., LAZO-WASEM, E. A., AND ZARROW, M. X. 1954. The presence of a functional corpus luteum during delayed implantation in the armadillo. *J. Endocrinol.*, **11**, 44-49.
- TANAKA, S., AND STARR, P. 1959. Clinical observations on serum globulin thyroxine-binding capacity using a simplified technique. *J. Clin. Endocrinol.*, **19**, 84-91.
- TEACHER, J. H. 1935. *Manual of Obstetrical and Gynaecological Pathology*. London: Oxford University Press.
- TEDFORD, M. D., AND YOUNG, W. C. 1960. Ovarian structure in guinea pigs made hermaphroditic by the administration of androgen prenatally (ABSTE). *Am. A. Anat., Anat. Rec.*, **136**, 325.
- TIJUNG, P. J., BOOT, L. M., AND MÜLLER, O. 1956. Smile changes in the oestrous cycle and in ovarian structure in some inbred strains of mice. *Acta endocrinol.*, **23**, 8-32.
- TROLLE, D. 1955a. Experimental and clinical investigations of the pregnanediol excretion in the human urine. *Acta endocrinol.*, **19**, 217-232.
- TROLLE, D. 1955b. Experimental and clinical investigations on the pregnanediol excretion in human urine. II. After injection of progesterone into normal men and women. *Acta endocrinol.*, **19**, 363-372.
- TRUM, B. F. 1950. The oestrous cycle of the mare. *Cornell Vet.*, **40**, 17-23.
- UMBAUGH, R. E. 1951. Superovulation and ovum transfer in cattle. *Fertil. & Steril.*, **2**, 243-252.
- VAN WAGENEN, G. 1945. Optimal mating time for pregnancy in the monkey. *Endocrinology*, **37**, 307-312.
- VAN WAGENEN, G. 1947. Early mating and pregnancy in the monkey. *Endocrinology*, **40**, 37-43.
- VAN ZYL, A. 1957. Serum protein-bound iodine and serum lipid changes in the baboon (*Papio ursinus*). I. During the menstrual cycle. *J. Endocrinol.*, **14**, 309-316.
- VELARDO, J. T. 1959. Steroid hormones and uterine growth. *Ann. New York Acad. Sc.*, **75**, 441-462.
- VELARDO, J. T. 1960. Induction of ovulation in immature hypophysectomized rats. *Science*, **131**, 357-359.
- VELARDO, J. T., AND HISAW, F. L. 1951. Quantitative inhibition of progesterone by estrogens in development of deciduonata. *Endocrinology*, **49**, 530-537.
- VELARDO, J. T., OLSEN, A. G., HISAW, F. L., AND DAWSON, A. B. 1953. The influence of decidual tissue upon pseudopregnancy. *Endocrinology*, **53**, 216-220.
- VERMANDE-VAN ECK, G. J. 1956. Neo-ovogenesis in the adult monkey. Consequences of atresia of oocytes. *Anat. Rec.*, **125**, 207-224.
- VEZIRIS, C. D. 1951. Cycle vaginal chez les femmes castrées ou ménopausées. *Ann. endocrinol.*, **12**, 915-921.
- WALTON, A., AND HAMMOND, J. 1928. Observations on ovulation in the rabbit. *Brit. J. Exper. Biol.*, **6**, 190-204.
- WARWICK, T. 1940. A contribution to the ecology of the musk-rat (*Ondatra zibethica*) in the British Isles. *Proc. Zool. Soc. London, ser. A*, **110**, 165-201.
- WESTMAN, A. 1958. The influence of x-irradiation on the hormonal function of the ovary. *Acta endocrinol.*, **29**, 334-346.
- WHITE, R. F., HERTIG, A. T., ROCK, J., AND ADAMS, E. 1951. Histological and histochemical observations on the corpus luteum of human pregnancy with special reference to corpora lutea associated with early normal and abnormal ova. *Contra. Embryol.* *Carnegie Inst., Washington*, **34**, 55-74.
- WHITTEN, W. K. 1955. Endocrine studies on delayed implantation in lactating mice. *J. Endocrinol.*, **13**, 1-6.
- WILKINS, L. 1949. Hyperadrenocorticism. *Pediatrics*, **3**, 533-548.
- WILKINS, L., CRIGLER, J. F., JR., SILVERMAN, S. H., GARDNER, L. I., AND MIGEON, C. J. 1952. Further studies on the treatment of congenital adrenal hyperplasia with cortisone. II. The effects of cortisone on sexual and somatic development, with an hypothesis concerning the mechanism of feminization. *J. Clin. Endocrinol.*, **12**, 277-295.
- WILLIAMS, P. C. 1944. Ovarian stimulation by oestrogens: effects in immature hypophysectomized rats. *Proc. Roy. Soc. London, ser. B*, **132**, 189-199.
- WILLIAMS, P. C. 1945a. Ovarian stimulation by oestrogens. II. Stimulation in the absence of hypophysis, uterus and adrenal glands. *J. Endocrinol.*, **4**, 125-126.
- WILLIAMS, P. C. 1945b. Studies on the biological action of serum gonadotrophin. II. Ovarian response after hypophysectomy and oestrogen treatment. *J. Endocrinol.*, **4**, 131-136.
- WILLIAMS, P. C. 1956. The history and fate of redundant follicles. *Ciba Foundation Colloquia Ageing*, **2**, 59-68.
- WILLIAMS, R. G. 1950. Studies of living interstitial cells and pieces of seminiferous tubules in autogenous grafts of testis. *Am. J. Anat.*, **86**, 343-369.
- WILLIAMS, S. M., GARRIGUS, U. S., NORTON, H.

- AND NALBANDOV, A. V. 1956. The occurrence of oestrogens in pregnant ewes. *J. Anim. Sci.*, **15**, 978-983.
- WELLSATT, W. A. 1944. Growth of the ovarian follicle and ovulation in *Myotis lucifugus*. *Am. J. Anat.*, **74**, 129-174.
- WOLFE, J. M. 1943. The effects of advancing age on the structure of the anterior hypophyses and ovaries of female rats. *Am. J. Anat.*, **72**, 361-383.
- WOLFE, J. M., AND WRIGHT, A. W. 1943. A comparative study of the anterior hypophysis and the ovaries of two strains of rats. *Cancer Res.*, **3**, 497-508.
- WOLSTENHOLME, G. E. W. (ED.) 1952. *Steroid Metabolism and Estimation*. Ciba Foundation Colloquia on Endocrinology, Vol. 2. Boston: Little, Brown & Company.
- YOUNG, W. C. 1941. Observations and experiments on mating behavior in female mammals. *Quart. Rev. Biol.*, **16**, 135-156, 311-335.
- YOUNG, W. C., DEMPSEY, E. W., MYERS, H. L., AND HAGQUIST, C. W. 1938. The ovarian condition and sexual behavior in the female guinea pig. *Am. J. Anat.*, **63**, 457-487.
- YOUNG, W. C., AND FISH, W. R. 1945. The ovarian hormones and spontaneous running activity in the female rat. *Endocrinology*, **36**, 181-189.
- YOUNG, W. C., AND YERKES, R. M. 1943. Factors influencing the reproductive cycle in the chimpanzee; the period of adolescent sterility and related problems. *Endocrinology*, **33**, 121-154.
- ZACHARIAE, F. 1957. Studies on the mechanism of ovulation. Autoradiographic investigations on the uptake of radioactive sulphate ( $^{35}\text{S}$ ) into the ovarian follicular mucopolysaccharides. *Acta endocrinol.*, **26**, 215-223.
- ZACHARIAE, F. 1958. Studies on the mechanism of ovulation. Permeability of the blood-liquor barrier. *Acta endocrinol.*, **27**, 339-342.
- ZACHARIAE, F., AND JENSEN, C. E. 1958. Studies on the mechanism of ovulation. Histochemical and physicochemical investigations on genuine follicular fluids. *Acta endocrinol.*, **27**, 343-355.
- ZANDER, J. 1951. Progesterone in human blood and tissues. *Nature, London*, **174**, 406-407.
- ZANDER, J., FORBES, T. R., VON MÜNSTERMANN, A. M., AND NEHER, R. 1958. Two naturally occurring metabolites of progesterone—isolation, identification, biologic activity, and concentration in human tissues. *J. Clin. Endocrinol.*, **18**, 337-353.
- ZANDER, J., AND SIMMER, H. 1951. Die chemische Bestimmung von Progesteron in organischen Substraten. *Klin. Wchenschr.*, **32**, 529-540.
- ZARROW, M. X., AND NEHER, G. M. 1953. Studies on the validity of the Hooker-Forbes test for the determination of progesterone in untreated blood. *J. Clin. Endocrinol.*, **8**, 203-209.
- ZARROW, M. X., NEHER, G. M., LAZO-WASEM, E. A., AND SALIHANICK, H. A. 1957. Biological activity of certain progesterone-like compounds as determined by the Hooker-Forbes bioassay. *J. Clin. Endocrinol.*, **17**, 658-666.
- ZARROW, M. X., CALDWELL, A. L., HAFEZ, E. S. E., AND PINCUS, G. 1958. Superovulation in the immature rat as a possible assay for LH and HCG. *Endocrinology*, **63**, 748-758.
- ZONDEK, B. 1940. On the mechanism of action of gonadotrophin from pregnancy urine. *J. Endocrinol.*, **2**, 12-20.
- ZONDEK, B. 1954. Some problems related to ovarian function and to pregnancy. *Recent Progr. Hormone Res.*, **10**, 395-423.
- ZONDEK, B., AND ASCHHEIM, S. 1927. Hypophysenvorderlappen und Ovarium. Beziehungen der endokrinen Drüsen zur Ovarialfunktion. *Arch. Gynäk.*, **130**, 1-45.
- ZONDEK, B., AND SKLOW, J. 1942. Further investigations on the mechanisms of oestrone production in the ovary. *J. Endocrinol.*, **3**, 1-4.
- ZUCKERMAN, S. 1940-41. Periodic uterine bleeding in sprayed rhesus monkeys injected daily with a constant threshold dose of oestrone. *J. Endocrinol.*, **2**, 263-267.
- ZUCKERMAN, S. 1951. The number of oocytes in the mature ovary. *Recent Progr. Hormone Res.*, **6**, 63-109.

# 8

## THE MAMMALIAN FEMALE REPRODUCTIVE CYCLE AND ITS CONTROLLING MECHANISMS

*John W. Everett, Ph.D.*

PROFESSOR OF ANATOMY, DUKE UNIVERSITY  
DURHAM, NORTH CAROLINA

I. INTRODUCTION.....	497	B. Luteolytic Mechanisms.....	537
II. CYCLES SPONTANEOUSLY INTERRUPTED.....	498	C. Effect of the Uterus on Luteal Function.....	538
III. PITUITARY-OVARIAN DORMANCY.....	499	VIII. CONCLUDING COMMENTS.....	540
A. The Ovary in Anestrus.....	500	IX. REFERENCES.....	541
B. The Hypophysis.....	500		
C. Relationship of the Anestrus to the Seasons.....	501		
IV. ATTAINMENT OF MATURITY. EMERGENCE OF FULL OVARIAN FUNCTION.....	502		
V. FOLLICULAR CYCLES. GROWTH AND ATRESIA.....	504		
A. Correlation of Ovarian Secretion with the Follicular Cycle.....	507		
B. Cyclic Manifestations after Ovariectomy or Hypophysectomy.....	509		
C. Cyclic Manifestations in the Absence of Ovarian Follicles.....	509		
D. Hypothalamus and Gonadotrophin Secretion. General Considerations.....	510		
VI. FOLLICLE MATURATION AND OVULATION.....	513		
A. Time of Ovulation.....	513		
B. Ovarian Steroids and Ovulation.....	514		
1. Estrogens.....	514		
2. Gestagens.....	517		
C. Role of the Nervous System in Ovulation.....	520		
1. The hypophyseal portal veins and the chemotransmitter hypothesis.....	523		
2. Central depressants and ovulation.....	526		
3. The central nervous system as a timing mechanism for ovulation.....	526		
D. Persistent Follicle.....	529		
VII. THE LUTEAL PHASE.....	530		
1. Luteotrophic substances.....	530		
2. "Nonfunctional" corpora lutea.....	531		
A. Pseudopregnancy.....	532		
1. Duration of pseudopregnancy.....	533		
2. Neural factors in pseudopregnancy.....	534		

### I. Introduction

The chain of events that constitutes the female reproductive process is characteristically repeated from time to time with considerable regularity during the adult life of an individual, and is therefore a cycle. In the broad sense, this sequence begins with oogenesis and terminates when the progeny require no further shelter and nurture. In mammals this has become a highly complex process, involving profound maternal adjustments synchronized with successive stages in development of the ovum, fetus, and offspring. The complete mammalian cycle comprises a sequence of stages which may be identified as follows: (1) *follicle growth*, including growth of the oocyte; (2) *ovulation*, a progressive process including preovulatory maturation of follicles and ova, and the structural change of ruptured follicles to corpora lutea; (3) *progravidity*; (4) *gravidity*; (5) *parturition*; and (6) *postpartum nurture*, including lactation, protection, and training. Although it is obvious that this full sequence is often realized, it may nevertheless be retarded or frankly interrupted at almost any point.

In advanced human societies economic and social factors have diminished the number of complete cycles to such degree that they are rarities in the lifetime of an in-

dividual and infertile ("menstrual") cycles are the rule. Inasmuch as corresponding factors operate among domesticated animals, the expression "female reproductive cycle" commonly refers to those truly abortive cycles that succeed one another in the absence of insemination. The term is used in that restricted sense in this chapter.

With even that restriction, the female cycle is actually a multiplicity of interlocking cycles, in which the rhythmic interplay between hypophysis and ovary is fundamental. Attention must therefore be focused on the physiology of the ovary and on the hormonal and neural mechanisms that integrate hypophysis and ovary as a functional system. Cyclic alterations in sex accessories and other nongonadal tissues are considered mainly as indicators. The "menstrual cycle," being strictly a uterine cycle, comes in this category, together with changes in behavior.

No attempt is made to present an exhaustive description of the varied adaptive modifications of the ovarian cycle among the several mammalian orders. The reader may consult works of the late F. H. A. Marshall whose full bibliography is given by Parkes (1949). Asdell's *Patterns of Mammalian Reproduction* (1946) is another valuable source.

## II. Cycles Spontaneously Interrupted

Cycles in the natural state are only imperfectly known, from random and often erratic sampling. One may safely assume that, as a rule, under optimal conditions they are complete, fertile cycles. There are, then, relatively few subhuman species in which the characteristics of incomplete cycles have been studied. These species are necessarily the very ones that have been amenable to some form of human restraint.

Segregation of the sexes or any other interference with insemination should be regarded as a first experimental approach to understanding the complete cycle. Such factors unquestionably operate in nature on occasion. Controlled changes of environmental conditions afford another approach in which natural factors are simulated.

The statement was made earlier that the complete cycle may conceivably be interrupted at almost any point. It has been

learned that in different species segregated females interrupt their cycles at different stages and that usually the point of interruption is species-characteristic. These facts have been of great service to the study of reproduction, first, by arousing the curiosity of the investigator and, second, by supplying a variety of ready made conditions individually appropriate for particular experimental studies.

Examples of mammalian cycles are schematically diagrammed in Figure 8.1. It is customary to state that the usual, or standard, infertile cycle is like that in primates or the guinea pig. The follicular phase culminates in *spontaneous ovulation*, after which corpora lutea are organized and become spontaneously functional for a period of time that is usually considerably shorter than in pregnancy.

In a few animals (rat, mouse, hamster) the cycle terminates shortly after ovulation before the corpora lutea become fully functional. Such corpora lutea are said to be inactive, in the sense that they cannot produce a decidual response to uterine trauma (Long and Evans, 1922). Sterile mating or analogous stimulation induces a luteal phase which corresponds to that of the "standard" mammal. This phenomenon is not entirely limited to the small rodents, having been described in the European hedgehog (Deanesly, 1934).

To this writer's knowledge there have not been described any mammalian species in which it is the rule that in isolated females the process of ovulation begins (follicle maturation, prelutein changes in granulosa, secretion of secondary liquor folliculi, and so on) without proceeding to eventual rupture of the follicles. Many cases could be cited, however, in which this has occurred "abnormally." Characteristically, some degree of luteinization occurs in the wall of such a follicle and a lutein cyst is formed.

On the other hand, there are numerous species (*triflex ovulators*) in which the pre-ovulatory maturation of follicles and ovulation nearly always fail in the absence of the male. The known species in which this is true are widely distributed among the mammalian orders and are often closely related to other species in which spontaneous ovulation is usual. The domestic rabbit

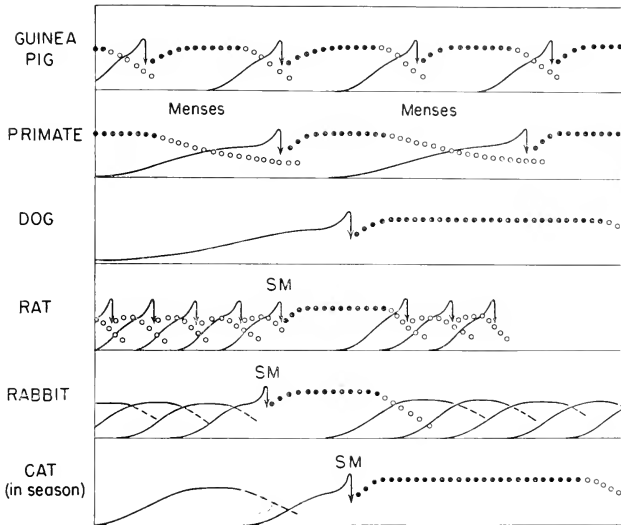

FIG. 8.1. Diagrams of cycles of representative, familiar mammals. —, the follicular phase, highly schematized and inaccurate in detail; ----, atresia; ↓, ovulation; ●, fully active corpora lutea; ○, corpora lutea regressing or otherwise not fully active. When sterile mating or equivalent stimulation (SM) is introduced, the cycles of the rat, rabbit and cat become directly comparable with those of the other species.

furnishes the classic example of reflex ovulation. Other reflex ovulators are the domestic cat (Greulich, 1934), the ferret (Hammond and Walton, 1934), mink (Hansson, 1947), marten (Pearson and Enders, 1944), the 13-lined ground squirrel (Foster, 1934), and the mole shrew (Pearson, 1944). To this list have been added the muskrat (Miegel, 1952) and a field mouse, *Microtus californicus* (Greenwald, 1956). Even among the marsupials, the female *Didelphys azarac* is said not to form corpora lutea in the absence of the male (Martinez-Esteve, 1937). A few of these species display nearly constant estrus (rabbit, ferret), competent follicles being present most of the time in the isolated female during the breeding season.

Among even the spontaneous ovulators the cycle may sometimes not progress beyond the follicular phase. Thus, at the approach of puberty, waves of advanced follicle development and secretion of estrogen may take place without, however, leading to ovulation or corpus luteum forma-

tion. The first cycles of primates are often anovulatory ones. In the adult macaque, at least in some colonies, such cycles are characteristic during the summer months (Hartman, 1932). A somewhat comparable seasonal effect has been reported in girls soon after the menarche (Engle and Shelesnyak, 1934). Menstrual cycles without ovulation have frequently been recognized in adult women in recent years, bearing no evident relationship to seasonal factors (López Colombo de Allende, 1956). Anovulatory cycles were described in the mouse by Allen (1923) and have been noted occasionally in other species, but without clear measure of their incidence.

### III. Pituitary-Ovarian Dormancy

Varying levels of pituitary-ovarian dormancy are expressed in different ways from species to species or even from habitat to habitat within a given species. A general similarity exists between the anestrus of seasonal breeders and the prepubertal state. In fact, in animals that have a distinct sea-

son, puberty occurs at the very time when older females are emerging from anestrus. Whereas anestrus is often correlated with season of the year, there are exceptions, notably among dogs, in which the correlation is ill defined (Engle, 1946).

In its shortest form ovarian quiescence lasts for only a few days, probably often without being recognized, between the end of one cycle and the active follicular phase of the next. In the chimpanzee it is thought to be the chief factor in the irregularity of length of the cycle (Young and Yerkes, 1943). Rossman and Bartelmez (1946) described a comparable occurrence in monkeys. At the other extreme, anestrus may occupy the major part of the year in monestrous animals that have a very limited breeding season.

#### A. THE OVARY IN ANESTRUS

Generally speaking, depression of ovarian function is most extreme in greatly prolonged periods of quiescence. In the ferret, Hammond and Marshall (1930) reported that in the anestrus ovary follicles can hardly be recognized with the naked eye, because they remain small and deeply placed. The largest follicles at the "end of the season" averaged 460  $\mu$  in diameter whereas a "long time after" the average was only 240  $\mu$ , increasing again to 720  $\mu$  at the approach of a new season. By contrast, the largest follicles of animals in full heat ranged between 1220 and 1440  $\mu$ . Follicle atresia abounds in the anestrus ovary of the 13-lined ground squirrel (Johnson, Foster and Coco, 1933). In sheep, however, follicles of large size may be present at any time during anestrus (Kammlade, Welch, Nalbandov and Norton, 1952).

Some moderate degree of secretory activity of the ovary is indicated even at the depth of prolonged seasonal anestrus (13-lined ground squirrel, Moore, Simmons, Wells, Zalesky and Nelson, 1934; ferret, Hill and Parkes, 1933; opossum, Risman, 1946). Although at this time uterus, vagina, and vulva are small, ovariectomy or hypophysectomy causes a further reduction. On the other hand, these structures are readily stimulated by injection of estrogens.

It may be said that low-grade follicular cycles proceed throughout the anestrus

interval, but whether there is any synchronization of one follicle with another is unknown. Some insight into this problem is furnished by study of (1) the transition from anestrus to the breeding season, and (2) the closely analogous phenomena of adolescence. In the report by Hammond and Marshall, it was shown that in ferrets during anestrus and proestrus there is a progressive increase in size of the vulva which directly parallels the diameter of the largest follicles. The absence of overt cyclic change is not surprising in view of the fact that estrus is continuous in this species. In polyestrous animals, on the other hand, it might be expected that during anestrus follicle growth and accompanying estrogen secretion are cyclic, at least at the approach of puberty or of "the season." Important information on this question has been obtained from some of the primates, notably the macaque (Allen, 1927; Hartman, 1932) and the chimpanzee (Zuckerman and Fulton, 1934; Schultz and Snyder, 1935).

Slight transitory reddening of the skin of the perineum ("sex skin") of the monkey may occur at intervals for several months preceding the onset of menses, accompanied by moderate desquamation of vaginal epithelium. During the long intervals of amenorrhea that some individuals exhibit during the summer, there is a tendency toward cyclic vaginal desquamation (Fig. 8.2). The sex skin of the chimpanzee may begin to swell more than a year before the first menstruation. During the ensuing months the swelling may be irregularly cyclic or continuous. Thus, one may judge that low-grade follicular cycles, accompanied by periodic increases in estrogen secretion, may succeed one another during seasonal or prepubertal anestrus, but that in certain cases these cycles may overlap to such degree that rather continuous estrogen secretion takes place.

#### B. THE HYPOPHYSIS

The secretory activity of the anestrus ovary is apparently adequate to prevent "castration" changes in the adenohypophysis, for as shown by Moore, Simmons, Wells, Zalesky and Nelson (1934) removal of the ovary of anestrus ground squirrels results in hypertrophy of the hypophysis.



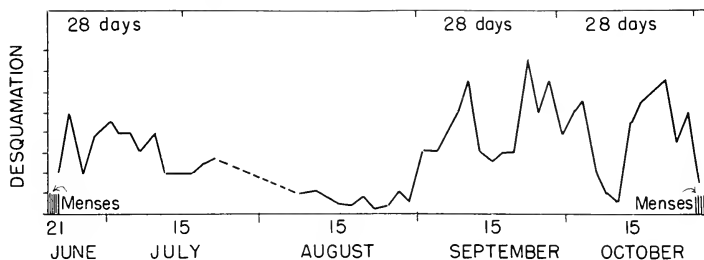

FIG. 8.2. Vaginal cycles during seasonal amenorrhea in a monkey. (A portion of the record of monkey #38 from C. G. Hartman, *Contr. Embryol.*, Carnegie Inst. Washington, **13**, Fig. 26, p. 121, 1932.)

increased gonadotrophin content thereof, and increased numbers of basophile cells. Warwick (1946) reported a highly significant increase of pituitary potency in spayed anestrus ewes. This is closely analogous to the results of ovariectomy in immature animals (Hohlweg, 1934). As measured by ovarian activity, gonadotrophin secretion (release) may be greatly diminished during profound anestrus. The actual hypophyseal content of gonadotrophin seems to be markedly reduced during anestrus in some species (Moore, Simmons, Wells, Zalesky and Nelson, 1934), but possibly not in others. Cole and Miller (1935) and Warwick (1946) reported that there is no seasonal variation in sheep. A study by Kamlade, Welch, Nalbandov and Norton (1952) indicates that the average content is somewhat higher during anestrus than it is in cycling ewes. The major factor in this difference, however, seems to be that during the cycle the potency of the pituitary drops during estrus and the early luteal phase.

Somewhat similarly the potency of the immature rat hypophysis has been stated to be as high as that of the sexually active adult (Clark, 1935). The fact that the ovaries of the immature female or of the anestrus adult can be stimulated by injection of gonadotrophin indicates that gonadotrophin content of the hypophysis in these cases is not a fair measure of liberation of the hormone into the blood stream. Therefore, it seems justifiable to assume, as Robinson (1951) did in the interpretation of anestrus in the ewe, that, in spite of the possible absence of seasonal assay variation,

there is, nevertheless, a depression of hypophyseal gonadotrophin release during anestrus. We may further assume that it is not completely depressed, for the ovary remains slightly active. Ovary and hypophysis are evidently in a state of equilibrium at a relatively low level of function. It seems likely that this state of affairs is brought about by the central nervous system, inasmuch as the seasonal depression in some species is closely dependent on the daily ratio of light to darkness.

#### C. RELATIONSHIP OF THE ANESTRUM TO THE SEASONS

This relationship is so varied among different species that many interesting questions are raised. In many cases the midpoint of anestrus coincides approximately with the shortest days of the year (Fig. 8.3). There are other examples, however, largely among the Artiodactyla, in which it coincides with the longest days. Sheep are notable examples (Robinson, 1951). Others, like the European common hare, experience a short anestrus during the time of rapidly decreasing daylight (Asdell, 1946). The Russian yak, on the other hand, is said to experience anestrus from December to May (*i.e.*, while day length is increasing). A general explanation of these varied adaptive manifestations is elusive. There is reason to believe that although illumination, or the light/darkness ratio, (Kirkpatrick and Leopold, 1952; Hammond, Jr., 1953) has a rather direct and primary effect in some cases, its role is more or less indirect in others where such things as temperature, humidity, availability of food and water assume major importance (Marshall, 1942).

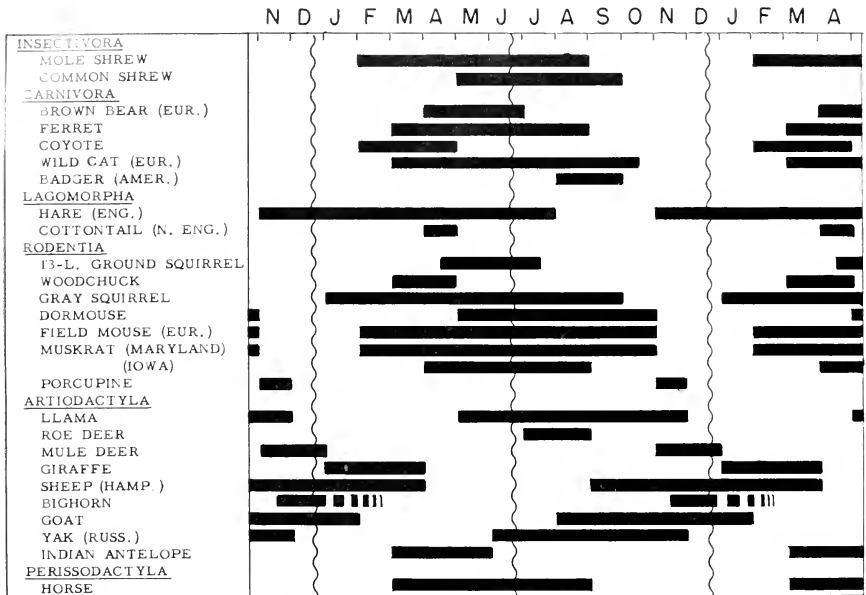

FIG. 8.3. Some representative seasonal breeders. Solid bars indicate breeding seasons (according to Asdell, 1946); blank intervals, periods of anestrus. Months of the year represented by letters at top of chart; winter and summer solstices marked by wavy lines. Southern hemisphere seasons converted to corresponding ones of the northern hemisphere. End of season for the Bighorn is uncertain.

The complexity of the problem is well illustrated by the 13-lined ground squirrel whose breeding season, like that of a multitude of small rodents, comes in the spring. Moore, Simmons, Wells, Zalesky and Nelson (1934) reported that increasing illumination, elevated temperature, and feeding all failed to bring the females into estrus out of season. If, however, hibernation was first induced by low temperature and darkness, premature estrus would follow. The conclusion was reached that hibernation itself is a necessary prerequisite. Ovarian development actually begins, under natural conditions, in early January in the midst of hibernation. Females experimentally maintained "continually for several months in cold and darkness, with more or less normal hibernation, [exhibit] sexual development at any time of the year, and periods of estrus have thus been . . . maintained for many months. . . ." The impres-

sion is given that the conditions favoring hibernation also favor sexual development to such extent that breeding potentiality continues for a few months after emergence, *in spite of* elevated temperatures and long periods of illumination. In another rodent, *Peromyscus leucopus*, however, the length of daily illumination is of paramount importance. Temperature changes (4 to 25°C.) have no effect on reproduction when lighting is adequate (Whitaker, 1940). Whereas a similar primary dependence on lighting can be shown in a number of other species from several orders, it is unwise to generalize that this is usually true.

#### IV. Attainment of Maturity. Emergence of Full Ovarian Function

Although emergence of the ovary from the state of quiescence is gradual, there is usually some outward sign that allows the observer to say that puberty has arrived or the breeding season has begun. In pri-

mates the accepted sign is the first menstruation; in rats it is the opening of the vagina; in many animals it is the swelling and reddening of the genitalia heralding the initial proestrus. In other cases, *e.g.*, sheep, the only clear indication may be the behavior of the female toward the male. From these facts it is readily apparent that any one sign is employed simply because it happens to be accessible to easy observation. Yet the increasing output of estrogen, whether steady or cyclic, affects many parts of the organism at the same time. Furthermore, in any one individual the threshold for expression of a given sign may be relatively high with respect to that of some other manifestation. Thus, in Hartman's monkeys (1932), some were noted in which desquamation of vaginal epithelium occurred in wave-like manner for a long time before menstruation. In others "menstrual" bleeding occurred with regularity while the uterus remained very small and vaginal desquamation was negligible.

Hartman summarized the step-wise manner of maturation of ovary and accessory organs of the monkey during adolescence or following amenorrhoeic episodes somewhat as follows. The color of the sex skin may be the first to appear. A slight menstrual flow usually takes place before desquamation of vaginal epithelium becomes measurable. "More rarely there may be one or more low desquamation cycles before a bleeding is recorded. Whole cycles marked by periodic bleeding and some vaginal desquamation may occur before there is any noticeable increase in size of the ovaries and uterus. These organs increase also in a saltatory manner, hence the term 'staircase' phenomenon for the process. Finally, the endocrine effect the acme of the reproductive process—ovulation."

Individual variation in the degree of abruptness with which the first ovulation is achieved is well illustrated in a study of pubertal guinea pigs by Ford and Young (1953). In most cases the first period of vaginal opening was much longer than in subsequent cycles. Whatever the duration, ovulation was more closely related to the end than to the beginning of the period, as indicated by histologic study of ovaries.

Even ovulation and corpus luteum for-

mation do not signify that full power of reproduction has arrived. For example, the first cycle of the adolescent rat may culminate in ovulation without sexual receptivity (Blandau and Money, 1943). In the ewe, an ovulation without overt signs of heat may at times take place during the anestrus, especially just before and just after the breeding season (McKenzie and Terrill, 1936). The phenomenon is occasional in ewes during the season and has also been described in cattle (Hammond, 1946). In fact, the full manifestation of estrus in sheep seems to require the presence of a "waning" corpus luteum (Robinson, 1951).

In sheep the transition from seasonal or prepubertal anestrus to the breeding season may involve relatively minor changes in hypophyseal activity. Even in the immature rat both the hypophysis and the ovary are capable of far greater secretory function than they normally display. In the equilibrium that prevails, the ovary appears to hold the upper hand by reason of a low hypophyseal threshold at which estrogen suppresses gonadotrophin secretion in the immature individual (Hollweg and Dohrn, 1932; Byrnes and Meyer, 1951b) and a low ovarian threshold at which gonadotrophin stimulates estrogen secretion. Byrnes and Meyer (1951a) reported that suppression of hypophyseal gonadotrophin content in immature rats can be accomplished with doses of estrogen much smaller than those that affect uterine growth. It is also known that the immature ovary can be induced experimentally to secrete estrogen by injection of amounts of gonadotrophin that are too small to produce significant increase of ovarian weight or follicle development (Levin and Tyndale, 1937; Moon and Li, 1952). When a gonadectomized immature rat is united in parabiosis (Kallas, 1929, 1930) with a normal or hypophysectomized female littermate, precocious puberty is induced in the latter animal because insufficient estrogen passes to the first partner to inhibit gonadotrophin secretion (see Finerty, 1952). The somewhat analogous experiment of transplanting ovaries to the spleen produces ovarian hypertrophy in much the same way. Here again, it is thought that the hypophysis becomes hypofunctional because the amount of estrogen

reaching the gland is greatly diminished, through inactivation by the liver (Biskind, 1941).

Although it is true that estrogens have a suppressing action on gonadotrophin secretion, it has become increasingly evident that they can also stimulate hypophyseal function in certain ways, as Engle proposed in 1931. Thus short-term injection of estrogen into intact immature rats and mice will invoke precocious puberty not only by stimulating the sex accessories, but also by increasing gonadotrophin secretion and thus causing ovarian growth and even ovulation. Frank, Kingery and Gustavson (1925) reported that after such treatment regular cycles continued after treatment was withdrawn. Lane (1935) found that when 22-day-old female rats were injected daily with estrogen there was an early increase in number of ovarian follicles, including vesicular stages. After the first 10 days the non-vesicular follicles became depressed although vesicular follicles were retained. This was interpreted to mean that for a short time estrogen actually stimulates the follicle-stimulating hormone (FSH) but eventually suppresses it, although luteinizing hormone (LH) secretion remains elevated. Hohlweg (1934) had already demonstrated that when somewhat older prepubertal rats are given single, rather large injections of estrogen, ovulation and corpus luteum formation are induced within a few days (p. 514). Obviously LH secretion is greatly increased.

Various bits of evidence implicate the nervous system in the processes leading to puberty and to the onset of estrus in seasonal breeders. This will be discussed in the following section with respect to the general question of the relationship of the hypothalamus to gonadotrophin secretion.

### V. Follicular Cycles, Growth and Atresia

Attention will be focused here on the dynamic pattern of follicle development throughout the cycle, the extent to which this pattern depends on hypophyseal control, and the functional changes in the ovary associated with estrus in preparation for the more specialized events that lead to ovulation and corpus luteum formation.

Production of primordial follicles and the early growth stages have been said to be independent of the hypophysis (Smith, 1939; Hisaw, 1947). This view derives from the fact that following hypophysectomy the ovaries retain large numbers of healthy proliferating follicles below the stage of antrum formation. There are, however, several indications that these developmental stages may be accelerated by gonadotrophic stimulation. It was briefly reported by Simpson and van Wagenen (1953) that administration of purified FSH to immature monkeys caused not only a 10- to 20-fold increase of ovarian weight, but also stimulation of granulosa in follicles of all sizes. Indirect evidence comes from the fact that follicle atresia generally becomes maximal late in estrus or metestrus, when depressed FSH might be expected on theoretical grounds. Harrison (1948) reported that in ovaries of goats killed on the third or fourth days of estrus healthy primary oocytes are rare. Some few, however, presumably remain. Myers, Young and Dempsey (1936) stated that in the estrous guinea pig there are few nonatretic follicles aside from those destined for ovulation. However, small numbers of normal appearing nonvesicular follicles were found.

There seems to be general agreement that, very quickly after this catastrophic elimination of follicles, renewed growth promptly ensues. Whether or not the wave of atresia represents a depression of FSH secretion, no one would deny that the new growth reflects this type of gonadotrophic stimulation. Characteristically the population of small and medium follicles is restored early in the luteal phase of the polyestrous cycle. This is clearly indicated for the guinea pig ovary (Myers, Young and Dempsey, 1936) when the data are converted from average volumes to average diameters (Fig. 8.4). Beginning on the fourth day after estrus, when the largest follicles are approximately 300  $\mu$  in diameter and when theca interna and antra have formed, rapid growth of granulosa, theca, and antra continues for several days. This is confirmed by counts of mitotic figures obtained by the colchicine technique (Schmidt, 1942), indicating greatest mitotic activity in theca and granulosa of follicles between 300  $\mu$  and 600  $\mu$  in diameter. By the

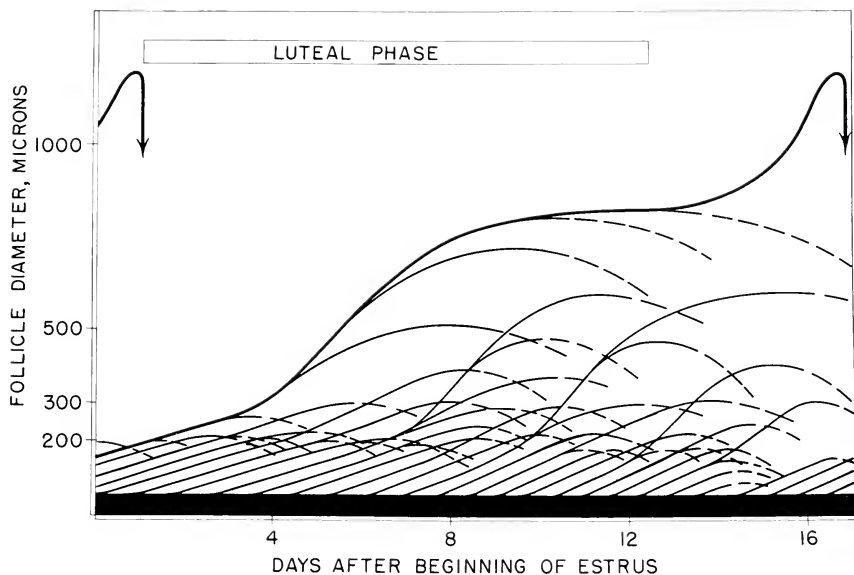

FIG. 84. A schematic representation of the follicular cycle in the guinea pig. The heavy solid curve represents the diameters of the largest follicles, recalculated from the data of Myers, Young and Dempsey (1936). The arrow point indicates ovulation. The other solid curves and broken lines represent impressionistically the growth and atresia, respectively, of other groups of follicles that are not ordinarily destined for ovulation.

11th or 12th day the largest follicles (ca.  $800 \mu$ ) are "competent," *i.e.*, capable of being ovulated (Dempsey, Hertz and Young, 1936; Dempsey, 1937). While the largest follicles are developing to this stage, multitudes of others begin to grow, being carried on to various stages of development before regression sets in.

This pattern of the follicular cycle seems to be generally true among mammals that have been carefully studied, when allowance is made for the fact that from one species to another the characteristic maxima of follicle diameter are extremely variable (shrew,  $350 \mu$ ; rat,  $900 \mu$ ; cow,  $19,000 \mu$ ; mare  $70,000 \mu$ ; Asdell, 1946). In ovulatory cycles of polyestrous animals the greater part of follicle growth is accomplished while the luteal phase of the preceding cycle is in progress. In successive anovulatory cycles like those of the cat the patterns of the follicular cycles are probably much the same (Evans and Swezy, 1931). In the rabbit and ferret, where more or less constant estrus char-

acterizes the isolated females in season, there is probably considerable telescoping of successive waves of follicle growth such that as one set of follicles begins to undergo atresia another set is ready to take its place (Hill and White, 1933). The difference between cat cycles and rabbit cycles seems to be chiefly one of degree. The writer has seen both types represented in persistent-estrous rats, among litter mates of inbred strains (Everett, 1939, and unpublished).

At the end of the luteal phase of the cycle in polyestrous animals there are already present several competent follicles among an extensive population of smaller ones. For example, the guinea pig corpus luteum usually shows signs of regression on day 13 of the cycle. It has been proved that ovulation can be induced as early as day 12 by injection of LH (Dempsey, 1937), several days earlier than it would normally occur (Fig. 8.5). In the human and monkey it is possible that the "preferred" follicles are recognizable by their larger size during

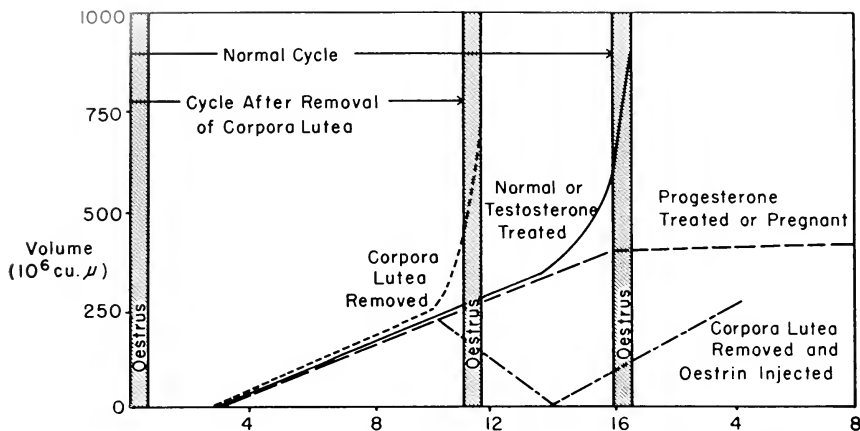

FIG. 8.5. The guinea pig follicular cycle and some of its experimental modifications. (After E. W. Dempsey, *Am. J. Physiol.*, **120**, 126-132, 1937.)

or soon after menstruation (Allen, Pratt, Newell and Bland, 1930; Hartman, 1932). In many mammals competent follicles may be present much earlier. Ablation of corpora lutea soon after ovulation in sheep (McKenzie and Terrill, 1936) and cattle (Hammond, Jr., and Bhattacharya, 1944) is followed in 2 to 4 days by another ovulation, much sooner than in the guinea pig (Fig. 8.5). Removal of the primate corpus luteum, at the other extreme, produces no such immediate response, judging from the details of three cases among Hartman's (1932) protocols (#40, #41, and #99). Whereas the next ovulations took place earlier than expectation, the intervals between unilateral ovariectomy and ovulation were 16, 14, and 22 days, respectively.

From detailed investigations in the rat, only the earlier stages of follicle growth may properly be regarded as pure FSH effects (Lane, 1935). Lane and Greep (1935) found that addition of LH to FSH causes a marked increase in the proportion of vesicular follicles to follicles without antra. The use of more highly purified materials (Greep, van Dyke and Chow, 1942; Franckel-Conrat, Li and Simpson, 1943) has amply confirmed the necessity for combination of the two gonadotrophins to yield maximal follicle growth and estrogen secretion in rats. Morphologic evidence indicates that

LH acts selectively on thecal tissue and, therefore, on the interstitial tissue derived therefrom. Inasmuch as thecal tissue is the presumptive major source of ovarian estrogen (see below), it follows, perhaps, as Hisaw (1947) suggested that "the theca interna through the action of LH acquires competence to respond to FSH" (by secreting estrogen).

Convincing evidence that thecal tissue and its derivatives are the principal sources of ovarian estrogen was assembled by Corner (1938). The status of this question remains essentially the same today. Few endocrinologists, however, would assume that no other ovarian cells have this capacity (see discussion in the chapter on the ovary). Nevertheless, there is a direct correlation in time between the marked rise in estrogen secretion as the follicular phase of the cycle advances, on the one hand, and the organization of theca interna of the largest follicles into organs of obvious endocrine character, on the other. When especially prominent the theca interna is referred to as the "thecal gland" (Mossman, 1937; Stafford, Collins and Mossman (1942).

Thecal tissue from the multitudes of atretic follicles should not be neglected as a possible additional source of estrogen. From the standpoint of chronologic relations to the cycle this question has hardly

been touched. Pointing up our ignorance, Sturgis (1949) in a careful study of atresia of large follicles in the monkey ovary, speculated that their hypertrophied thecal tissue may serve the useful purpose of estrogen secretion during the interim between follicle rupture and organization of the corpus luteum.

We are in need of quantitative appraisals not only of the total numbers of healthy and atretic follicles of all categories present in representative species at progressive stages of the cycle, as in the work on the rat by Mandl and Zuckerman (1952), but also of the respective volumes of theca, granulosa, interstitial tissue, and corpora lutea. Lane and Davis (1939) determined in rat ovaries at four stages of the cycle the respective total volumes of theca, granulosa, and antra in all healthy follicles, as well as the separate mitotic indices of theca and granulosa. Such differential information on multiplication of cells and increase of antral volume is important. Although the latter accounts for a major part of the increase in volume of the larger follicles, it represents a function quite apart from protoplasmic growth *per se*.

There is now considerable evidence that estrogen itself exerts a growth-promoting influence on the follicle and, furthermore, sensitizes it to gonadotrophic stimulation. Details may be found in papers by Pencharz (1940), Williams (1940, 1944, 1945a, b), Simpson, Evans, Fraenkel-Conrat and Li (1941), Gaarenstroom and de Jongh (1946), and Deselin (1949a). Although it seems that these effects have not been elicited by physiologic doses, the possibility remains that estrogen operates within the confines of the ovary as a mediator of some of the effects of the gonadotrophins. In the neighborhood of cells that produce it the estrogen concentration is probably far above that which would be considered physiologic for the remainder of the body.

#### A. CORRELATION OF OVARIAN SECRETION WITH THE FOLLICULAR CYCLE

Knowledge of the secretory output of the ovary during the cycle is almost entirely indirect and derives chiefly from (1) substitution experiments carried out in a vari-

ety of species, and (2) assays of urine, mainly human but occasionally from other forms. Satisfactory assays of blood estrogen have been very limited and chemical analysis of the steroid content of ovarian venous blood is in only its preliminary stages.

The early substitution experiments are chiefly of historic interest (Allen, Danforth and Doisy, 1939). In great measure these investigations constitute crucial steps in proof that the ovary secretes steroid hormones which are fundamentally responsible for the manifestations of estrus. Conversely, then, these manifestations might be considered to reflect an increase of estrogen secretion and their absence a relative decrease. It has been learned, however, that the action of estrogen in certain instances may be greatly modified by progesterone, androgens, and certain adrenocortical steroids (notably desoxycorticosterone). Androgens are known to be secreted in the female by the adrenal cortex (Dorfman and van Wagenen, 1941; Gassner, 1952) and by the ovaries (Hill, 1937a, b; Parkes, 1950; Deanesly, 1938; Burrill and Greene, 1941; Pfeiffer and Hooker, 1942; Alloiteau, 1952). Progesterone secretion is probably not confined to the luteal phase of the cycle (see p. 519). Evidence for its secretion during follicle maturation is considerable and its possible production even earlier cannot be excluded. These considerations make it unwise, therefore, to regard phenomena such as vaginal cornification, turgescence of vulva and sex skin, uterine growth, as direct quantitative measures of estrogen output. This point may be illustrated by certain observations made in chimpanzees by Fish, Young and Dorfman (1941) and illustrated in Figure 8.6. Assays of urinary estrogens during the cycle exhibited two peaks, only the first of which coincided with the swelling of sex skin. The second peak of estrogen excretion was unaccompanied by swelling, presumably because of the coordinate increase of progesterone secretion. Had swelling been the only guide only the first peak would have been apparent.

Assays of urinary estrogen in primates have often shown double peaks such as illustrated for the chimpanzee. Pedersen-Bjergaard and Pedersen-Bjergaard (1943),

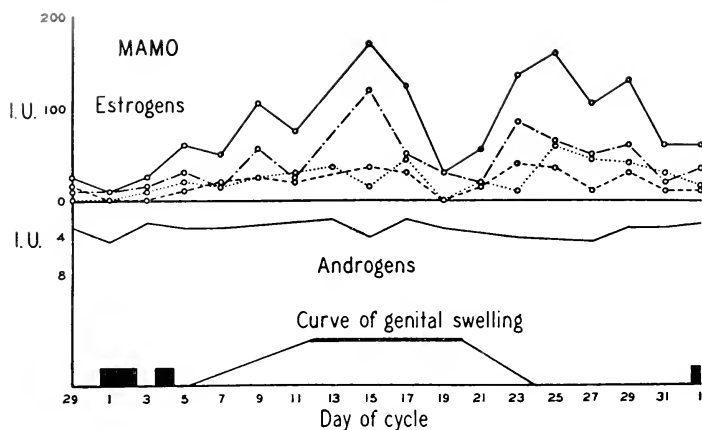

FIG. 8.6. Estrogen and androgen excretion by a female chimpanzee, *Mamo*. —, total estrogens; ----, estradiol; - · -, estrone; · · · ·, estriol. Menstruation indicated by solid areas on base line. (From W. R. Fish, W. C. Young and R. I. Dorfman, *Endocrinology*, **28**, 588, 1941.)

studying one woman for 2 years, found single peaks at midinterval in 8 cycles and double peaks in 12 cycles. On the average the first peak was reached on day 12 and the second on day 21. Similar double peaks were noted in blood estrogen assays in a large group of normal young women (Markee and Berg, 1944). An additional lesser rise was observed during menstruation.

None of the available assays of urinary or blood estrogen can be accepted as an absolute measure of the rate of hormone production. Urinary assays have certain advantages, in spite of the fact that probably only a variable fraction of the ovarian product is measured. Intrinsicly they are measures of rate, whereas assays of blood estrogen measure concentration alone at the moment of bleeding. Attempts have been made to measure estrogens in ovarian venous blood, but with little success because of the extreme dilution (Rakoff and Cantarow, 1950). We may hope that development of sufficiently sensitive methods of detection will soon allow systematic evaluation of ovarian output by such direct means. Tracer techniques have shown (Werthessen, Schwenk and Baker, 1953) in perfused ovaries of the sow that  $C^{14}$ -acetate enters into the synthesis of estrone and  $\beta$ -estradiol.

Several years ago Corner (1940) esti-

mated, from the known amounts of injected estrone required to maintain the normal status of sex skin and endometrium in castrates that the ovaries of an adult rhesus monkey secrete the equivalent of about 20  $\mu$ g. estrone daily. On a weight basis the estrone equivalent secreted by the ovaries of a woman would then be on the order of 300  $\mu$ g. per day. Actual substitution data from castrated women gave an estimate of the same order of magnitude (420  $\mu$ g. per day).

Whatever the rate of secretion may be at different times, it would seem *a priori* that effects on extra-ovarian tissues should be more directly related to amount of estrogen in circulation. The assays of human blood-estrogen in normal women by Markee and Berg (1944) and in gynecologic patients by Fluhmann (1934), although differing in absolute values, agree in indicating that the variation of blood estrogen concentration from one stage of the cycle to another may be relatively small. If this is true, then it must be supposed that cyclic changes in the accessory organs are brought about by relatively moderate changes in circulating estrogen. In support of this view Markee (1948) demonstrated in the macaque that a mere 50 per cent reduction in the daily dose of estrogen can invoke menstruation if the change is abrupt.



## B. CYCLIC MANIFESTATIONS AFTER OVARIECTOMY OR HYPOPHYSSECTOMY

Residual cyclic changes in the vagina have been reported in ovariectomized mice (Kostitch and Tělébakovitch, 1929) and rats (Mandl, 1951). The periodicity is very nearly that of the normal cycles, at least in the latter species. Vaginal cycles of similar duration with more extreme estrous changes are found in ovariectomized rats receiving daily injection of threshold doses of estrogens (del Castillo and Calatroni, 1930; Bourne and Zuckerman, 1941). The same was remarked in mice by Emmens (1939) and a report by Veziris (1951) indicates that vaginal periodicity may obtain in castrated or menopausal women receiving estrogen. Although such events have been called "threshold cycles," the term may simply express the fact that they are most easily recognized when estrogen is given at threshold level. Hartman (1944), employing a modified Shorr stain for vaginal smears, found that castrated rats given large amounts of estrogen daily (5 to 100  $\mu$ g. estradiol dipropionate) displayed complete cornification at 4- to 5-day intervals. During the time intervening there was admixture of Shorr cells, smaller epithelial cells, and leukocytes.

Analogous phenomena have been recognized in the endometrium of castrated monkeys (Zuckerman, 1937, 1941) injected daily for as long as 1 year with threshold doses of estrone (10  $\mu$ g.). Larger doses prevent cyclic bleeding (see Hisaw, 1942). From the report of Veziris (1951) it may be judged that threshold endometrial cycles also occur in women and that the vaginal and endometrial cycles are synchronized in considerable extent.

Full explanation of these phenomena is not at hand. From the standpoint of the present discussion certain considerations are especially noteworthy. (1) Vaginal "threshold cycles" have been obtained in castrated rats in the absence of either hypophysis or adrenals (Bourne and Zuckerman, 1941; del Castillo and di Paola, 1942). The former authors encountered the phenomenon in two rats from which both the hypophysis and adrenals had been removed. It is important

to remember, however, that the pars tuberalis remains *in situ* after the usual hypophysectomy procedure, that accessory adrenocortical tissue is frequent in rats, and that gonadal rests might remain unrecognized. (2) The reported lengths of vaginal and endometrial cycles agree favorably with the cycle lengths in intact individuals of the respective species. The degree of conformity between vaginal and uterine cycles indicated by Veziris (*loc. cit.*) suggests some sort of integrating mechanism. Much more information is required, however, before one may reject the alternative view that rhythmic activity is an innate characteristic of these organs.

## C. CYCLIC MANIFESTATIONS IN THE ABSENCE OF OVARIAN FOLLICLES

Many years ago Parkes (1926a, b) and Brambell, Parkes and Fielding (1927a, b) reported vaginal and uterine cycles in mice in which the entire follicular apparatus had been destroyed by x-radiation. Schmidt (1936) described the phenomenon in the guinea pig, noting that, although most of her estrous animals had one or more large atretic or cystic follicles, as she had earlier reported (Genther, 1931), a few animals exhibited periodic vaginal opening of short duration and correlated proestrous vaginal smears, in the absence of follicles. Her assays of urinary estrogen were negative in these animals, unlike the positive assays in those in which one or more follicles were demonstrable. Attempts by several workers (Drips and Ford, 1932; Levine and Witschi, 1933; Mandel, 1935) to reproduce in rats the results that Parkes and Brambell had found in mice, were unsuccessful, a fact indicating no estrogenic activity in ovaries completely lacking follicles and ova. Parkes (1952) more recently returned to this problem, reporting vaginal cycles and "fully functional" uteri in castrated rats bearing grafts of ovaries in which all organized follicles and oocytes had been destroyed by deep freezing. These were true estrous cycles, in the sense that the animals would mate.

Many questions are posed by these observations. The fundamental one seems to be whether these cycles express periodicity of hypophyseal gonadotrophin secretion.

The answer may be long in coming. Meanwhile, one would like to know whether castration changes are visible in the hypophysis and whether constant estrus may be invoked by exposure to continuous light or by post-natal treatment of the host with androgen or other steroids (see p. 529).

#### D. HYPOTHALAMUS AND GONADOTROPHIN SECRETION. GENERAL CONSIDERATIONS

Experimental studies, ostensibly addressed to the general problem of neural control of gonadotropin secretion, have in fact often been concerned with the special problems of reflex ovulation (p. 520) or of provoked pseudopregnancy (p. 532). Whereas substantial information is now available with respect to these special phenomena, particularly ovulation, information is limited about control of the day-to-day secretion of gonadotrophin that in the female is responsible for follicle stimulation and estrogen secretion (Benoit and Assenmacher, 1955; Harris, 1955). However, evidence in regard to induction of precocious puberty and early onset of estrus in seasonal breeders leaves no doubt that the nervous system is *in some manner* a regulator of follicle-stimulating activity of the pars distalis.

Numerous reports associate precocious puberty with lesions in the hypothalamus (Weinberger and Grant, 1941; Bauer, 1954; Harris, 1955). Donovan and van der Werff ten Bosch (1956) reported off-season estrus in ferrets and precocious puberty in rats following retrochiasmatic lesions in the hypothalamus. Exposure of immature rats to continuous light causes the vagina to open prematurely (Fiske, 1941). When 22-day-old female rats were given electrical stimulation of the cervix uteri daily for 10 days (Swingle, Scay, Perlmutter, Collins, Fedor and Barlow, 1951), a large proportion exhibited significant increase in uterine weight beyond that found in control animals, without change in ovarian weight. In fact, 7 of 50 rats ovulated or at least formed "several well-developed corpora lutea." Somewhat similarly, according to Aron and Aron-Brunetière (1953), mechanical stimulation of the vagina or the adjacent segment of the uterus in immature guinea pigs regularly

provoked follicle growth and estrogen secretion. In gregarious birds the development of ovulable follicles requires that other individuals of the species be present. In the pigeon, even the mirror image of the female constitutes a sufficient stimulus (Matthews, 1939).

Studies by Flerkó and his associates (1954-1957) present consistent evidence that restricted bilateral lesions in the region of the paraventricular nuclei serve to liberate the hypophysis from inhibitory effects of estrogen and androgen. This work is in agreement with that of Donovan and van der Werff ten Bosch in that somewhat similarly located lesions brought on precocious puberty. As noted elsewhere, gonadectomy in immature rats quickly results in hypersecretion of gonadotrophin.

Transplantation of the hypophysis to sites remote from the hypothalamus has produced divergent results. At the present writing, the chief divergence seems to rest between the sexes. In *male* guinea pigs and rats several workers have reported maintenance of male reproductive tracts by intra-ocular transplants of hypophyses (May, 1937; Schweizer, Charipper and Kleinberg, 1940; Cutuly, 1941a; Courier, 1956; Goldberg and Knobil, 1957). Quite to the contrary, however, there has at best been only equivocal evidence of maintenance of *female* tracts, a matter of sex difference which needs full investigation. May's (1937) report of 2 fertile female rats is unacceptable because of inadequate controls. Schweizer, Charipper and Haterius (1937) found in several hypophysectomized guinea pigs that intra-ocular pituitary grafts produced constant estrus and significant follicle stimulation, accompanied by uterine and mammary gland development. Although the search for pituitary remnants in the sella turcica was reported negative, the histologic check was limited to scrapings from the sella floor. Other authors, notably Phelps, Ellison and Burch (1939), Westman and Jacobsen (1940), Harris and Jacobsen (1952), and Everett (1956a) obtained in female rats little or no evidence of gonadotrophin secretion from apparently healthy, well vascularized grafts. The respective sites were intramuscular, intra-ocular, in the sub-

arachnoid space under the temporal lobe of the brain, and beneath the renal capsule—all distant from the hypothalamus.

Transplantation of the pars distalis into sites close to the hypothalamus, on the other hand, is characteristically followed by maintenance of the female reproductive tract and essentially normal sex functions. Greep (1936) found that re-implantation of hypophyses into the (presumably) emptied capsule was frequently followed in both male and female rats by return of virtually normal reproductive powers. Females exhibited cycles and even went through successful pregnancy and lactation. The result observed in male rats was confirmed by Cutuly (1941a). The obvious difficulty of establishing completeness of hypophysectomy has been the only criticism of these instructive experiments. This fault has been eliminated by an improved procedure devised by Harris and Jacobsohn (1952). Hypophysectomy was performed by the parapharyngeal route, after which the tissue to be grafted was introduced by a transtemporal approach to a site immediately beneath the median eminence. This permitted later histologic search for remnants of the original gland in its capsule. In many cases, including all in which the graft comprised several hypophyses from the animal's own newborn young, entirely normal gonadotrophic function was recorded. This included resumption of regular estrous cycles, typically during the 2nd or 3rd postoperative week. Several of the rats became pregnant and delivered viable litters. In marked contrast, none of the grafts that were placed under the temporal lobe gave any indication of gonadotrophin secretion, although they were as well preserved and richly vascularized as the others. Explanation of the difference seems to be that grafts under the median eminence acquire blood supply from regenerated hypophyseal portal veins and hence a neurovascular linkage with the hypothalamus. The importance of this relationship has been amply confirmed by Nikitovitch-Winer and Everett (1957, 1958d) in studies described below.

In lieu of significant numbers of nerve fibers entering the pars distalis (see Rasmussen, 1938; Harris, 1948a), the hypophyseal

portal veins afford the most likely means by which the gland is brought under hypothalamic control. Recently it was demonstrated in rats and monkeys that these vessels have the power of rapid regeneration after simple stalk-section (Harris, 1949, 1950a, b). This fact at once gives a ready explanation of many of the discordant results of stalk-section experiments reported in the past. Harris (1950b) explored in rats the efficacy of various materials as barriers to regeneration, with the result that numerous examples of partial regeneration were produced. Degree of recovery of gonadotrophic activity by the hypophysis was strikingly correlated with degree of anatomic vascular recovery. Restoration of normal ovarian function after simple interruption of the stalk, as reported in the guinea pig by Dempsey (1939), in rats by Dempsey and Uotila (1940), and in the human by Dandy (1940), is thus explained by the assumption that portal vein regeneration had taken place. On the other hand, Westman and Jacobsohn (1937-1938), who always inserted a barrier of metal foil between the median eminence and hypophyseal capsule, consistently found ovarian atrophy, as did Harris when portal vein regeneration was completely obstructed. Attempting to prove that the portal vessels are not essential in regulating the hypophysis, Thompson and Zuckerman (1954) stated that increased illumination induced estrus in two ferrets after stalk-section and in the absence of demonstrable regeneration of portal vessels. Donovan and Harris (1954), however, examining the histologic sections prepared from 1 of the 2 animals, found many such vessels that were uninjected. In their own experimental series, an estrous response to light was always associated with regeneration of the portal veins.

Greep and Barnett (1951) rightly emphasized the prime importance of a good vascular supply for recovery of function by the pars distalis after either transplantation or stalk-section. They pointed to the extensive central infarction and scarring that characteristically followed stalk-section by their technique, an obvious factor contributing to hypopituitarism. Harris (1950a), however, reported good function from sec-

eral hypophyses in which there was pronounced central necrosis in company with well regenerated portal vessels. A study by Nikitovitch-Winer and Everett (1957, 1958b) established beyond doubt that qualitative functional losses after stalk-section or transplantation of the pars distalis result, not from impaired blood supply *per se*, but from the loss of the intimate neurovascular relationship with the hypothalamus. Hypophyseal autografts, after first being placed under the kidney capsule for several weeks with the usual atrophy of the ovarian follicular apparatus and interstitial tissue, were later retransplanted to a site immediately under the median eminence. In the definitive series of 14 such experiments, 13 rats resumed estrous cycles spontaneously 8 to 68 days after retransplantation; 7 were fertile and carried litters to term. A correlated study (Nikitovitch-Winer and Everett, 1959) demonstrated clearly that on the occasion of each of these successive transplantations there was massive necrosis of the interior of the glandular mass, leaving but a thin shell from which the functional tissue of the graft was reconstituted. In spite of this double insult some special influence of the hypothalamus brought about renewed function in a surprising number of cases. Together with the restoration of gonadotrophic activity there was significant improvement in thyroid-stimulating hormone (TSH) and adrenocorticotrophic hormone (ACTH) secretion. The considerable net loss of hypophyseal parenchyma resulting from the two operations was reflected only *quantitatively* in the effects on the various target organs. Ovarian weights, numbers of follicles and corpora lutea, adrenal weights and extent of adrenal hypertrophy after unilateral adrenalectomy, and thyroid uptake of  $I^{131}$  were all intermediate between those of the normal female rat and control animals in which the graft remained on the kidney or was retransplanted under the temporal lobe of the brain.

Regulation of pars distalis secretion by means of the stalk vessels may conceivably be carried out either by regulation of blood flow or by transmission of chemical mediators from the proximal capillary plexus in the median eminence to the pars distalis. An

experiment described by Swingle, Seay, Perlmutter, Collins, Fedor and Barlow (1951) suggested that a mediator subject to Dibenamine blockade might be involved in precocious puberty. Although significant uterine enlargement was produced in immature rats by daily stimulation of the cervix uteri for 10 days, no such effects were observed in similar rats given Dibenamine daily by stomach tube. Unfortunately, there were no controls for the possible effect of Dibenamine in nonstimulated or gonadotrophin-injected animals.

Fluhmann (1952) invoked precocious vaginal opening and ovarian stimulation in immature rats by injection of neostigmine. The locus of such cholinergic action is unknown. Parenthetically, Barbarossa and di Ferrante (1950) reported follicle stimulation in immature rats after injection of intermedin, an effect not found in hypophysectomized subjects. Benoit and Assenmacher (1955) proposed that, in the drake, gonad-stimulating activity is governed by an agent contained in neurosecretory substance, which is demonstrable in abundance in the retrochiasmatic region of the median eminence. Capillaries there drain selectively into an anterior set of portal venules. Oxytocin has been suggested as a possible mediator for gonadotrophin secretion (Shibusawa, Saito, Fukuda, Kawai, Yamada and Tomizawa, 1955; Armstrong and Hansel, 1958). There is much interest as this is being written (1958) in the possibility that vasopressin, oxytocin, or other agents associated with neurosecretory substances of the neurohypophysis are responsible for control of production and release of the various trophic hormones of the pars distalis. As an alternative or even a supplement to neurochemical regulation, a vasomotor mechanism cannot be denied (Green, 1951), for conceivably only a slight shift in blood flow through the pars distalis might tip the balance of hormone production one way or another. Thus the matter stands: whereas it is apparent that the hypothalamus intervenes in follicle growth and estrogen secretion, how it does so is little more than speculative.

## VI. Follicle Maturation and Ovulation

A variety of evidence indicates discontinuity between growth of large follicles, on the one hand, and their preovulatory maturation, on the other. Such is clearly the case among "reflex ovulators." Evidence that the same is true for spontaneous ovulators will be outlined below. Follicle maturation, ovulation, and structural transformation of the follicles to corpora lutea seem to represent successive stages in a distinct physiologic process, superimposed on the follicle growth cycle and brought about by a relatively abrupt increase in circulating gonadotrophin (theoretically LH). Since there is evidence (p. 519) that progesterone secretion may become detectable as this process begins, there might be justification for regarding it as merely the first portion of the luteal phase. However, the fact that luteinization (*i.e.*, the organization *per se* of luteal tissue) does not necessarily lead to functional corpora lutea warrants treatment of the ovulation-luteinization phase as a distinct phenomenon.

Although it is customary to state that the hypophysis invokes ovulation by release of LH, there is considerable question about the auxiliary roles played by other gonadotrophic hormones (Hisaw, 1947). Inasmuch as the time of release has been known in only the reflex ovulators, one might look to them for information. However, the available data (Hill, 1934) pertain only to the ovulating potency of the total gonadotrophin content of the hypophysis at various times after coitus. Substitution experiments are unsatisfactory because the presence of competent follicles implies the presence of both FSH and a small amount of LH. The substitution of even the purest hormone preparations immediately after hypophysectomy leads to equivocal results inasmuch as it must be assumed that some FSH and LH of intrinsic origin remain in circulation. Talbert, Meyer and McShan (1951) determined that in rats, when hypophysectomy is performed at the onset of proestrus, the follicles remain capable of responding to injected LH for about 6 hours. Morphologic signs of follicle deterioration do not appear until much later. Adding to the uncertainty

is the fact that relatively pure preparations of either FSH or LH will ovulate an estrous rabbit (Greep, van Dyke and Chow, 1942). On the other hand, until the recent use of species-specific gonadotrophins (van Wagenen and Simpson, 1957), the primate ovary was notoriously difficult to ovulate therapeutically. Until effluent blood from the hypophysis can be assayed, there is little likelihood that the gonadotrophin complex that is normally responsible for ovulation can be known. Thus, whereas the expression, LH-release, will be employed occasionally to refer to the release of gonadotrophin that invokes ovulation, the term is used purely for convenience and brevity, and should be appropriately qualified by the reader.

### A. TIME OF OVULATION

The time of ovulation with respect to other events of the cycle is relatively easy to determine in reflex ovulators, but in spontaneous ovulators has proven to be more elusive. In the former, laparotomy at various intervals after the stimulus enables exact measure to be made of the time required to accomplish ovulation. For most of the spontaneous ovulators, save the few in which the ripening follicles can be palpated as in monkeys and cattle, it has been necessary to attempt to correlate ovulation with some easily detectable external sign. Inasmuch as the ovulation stimulus to the hypophysis in these animals is probably invoked by ovarian hormones and these are equally responsible for phenomena such as vaginal cornification and behavioral estrus, a considerable degree of correlation might be expected between ovulation and a given change in the vaginal smear or onset of estrous behavior. The predictability of the relationship, however, must depend in great measure on the degree of correlation among thresholds of response in the various tissues concerned. In the primates that have no sharply limited period of sex desire the problem is even more troublesome. When reference is made to the date of the last menstruation, prediction is erratic because of the variable occurrence of postmenstrual quiescence (Rossman and Bartelmez, 1943; Young and Yerkes, 1943). Consequently, attempts must be made to find indicators

such as basal body temperature fluctuations which may bear some intrinsically closer relationship to the event in question. (See Hartman, 1936, and Buxton and Engle, 1950, for discussion of this very practical problem.)

Among mammals generally, spontaneous ovulation takes place sometime during estrus (Asdell, 1946). It is found during early estrus in the opossum, red fox, dog, mouse and hamster. In the rat some authors have placed it early (Young, Boling and Blandau, 1941) and others late (Long and Evans, 1922) with respect to vaginal estrus. In the writer's colony both relations hold, in 4-day and 5-day cycles, respectively. Ovulation in late estrus is reported for the cotton rat, bank vole, guinea pig, pig, horse, and ass. Sheep usually ovulate shortly before the end of heat, sometimes a few hours afterward. As stated earlier, ovulation may even occur in guinea pigs, rats, sheep, and cattle without overt estrus. The cow usually ovulates several hours after the end of heat. The marsupial cat is said to ovulate 5 days afterward (Hill and O'Donoghue, 1913). The extreme is represented by certain bats (Asdell, 1946) which copulate in autumn and ovulate in the spring after a prolonged state of subestrus. These variations probably express several factors.

Among reflex ovulators there is considerable interspecies variation in the interval between the stimulus that invokes release of gonadotrophin from the hypophysis and the eventual rupture of the Graafian follicles (rabbit, ca. 10 hours; ferret, ca. 30 hours; cat, 24 to 54 hours; 13-lined ground squirrel, 8 to 12 hours; mink, 36 to 50 hours). Among spontaneous ovulators the comparable interval is clearly defined for only the rat, 10 to 12 hours (Everett, Sawyer and Markee, 1949). In the cow the data obtained by Hansel and Trimberger (1951) and Hough, Bearden and Hansel (1955) place the outside limit at about 30 hours. Here again, threshold differentials among the various tissues of the individual are probably of great importance. Thus in one species the threshold for gonadotrophin release may be lower than that for estrous behavior with the result that by the time the latter makes its appearance the former has already transpired and

ovulation will shortly take place. The rat, for example, releases LH during the afternoon, begins to show estrous behavior around 8 P.M., and ovulates around 2 A.M. (Everett, 1948, 1956b). In other species these time relationships may be reversed. In the cow, activation of the hypophysis apparently occurs several hours after the onset of estrus (Hansel and Trimberger, 1951). The cow remains in heat 10 to 18 hours and ovulates 13½ to 15½ hours after going out of heat (Asdell, 1946). The early termination of estrus apparently reflects a refractory state which sets in after estrogen activity has continued for a time, for castrates receiving continued estrogen therapy remain in estrus for similarly brief periods. In the mare, ovulation is delayed until a few hours before the end of estrous periods that may extend for 5 to 10 days or longer. This suggests a relative refractoriness of the LH-release mechanism in this animal. Such a state of affairs approaches that in persistent estrus or in the anovulatory cycle.

## B. OVARIAN STEROIDS AND OVULATION

### 1. *Estrogens*

Chronic administration of estrogen to the intact animal eventually produces ovarian atrophy by suppression of gonadotrophin secretion. However, some moderate basic level of continuous estrogen secretion must be compatible with normal function of the hypophyseal-ovarian system; witness the fact that blood estrogen assays in normal women (Markee and Berg, 1944) indicate only a 2-fold increase at midinterval above a base value of considerable magnitude.

Induction of corpus luteum formation by injected estrogen was first demonstrated by Hohlweg (1934) in prepubertal rats<sup>1</sup> and the phenomenon has been repeatedly observed by other workers (Desclin, 1935; Mazer, Israel and Alpers, 1936; Westman and Jacobsen, 1938b; Herold and Effkenmann, 1938; Price and Ortiz, 1944; Cole, 1946). The fact that the effect was not obtained in rats younger than 30 to 36 days by Price and Ortiz, whereas Cole observed it in the age-range of 21 to 28 days, demon-

<sup>1</sup>The effect was later obtained with androgens (Hohlweg, 1937; Salmon, 1938; Nathanson, Francis and Swenney, 1938).

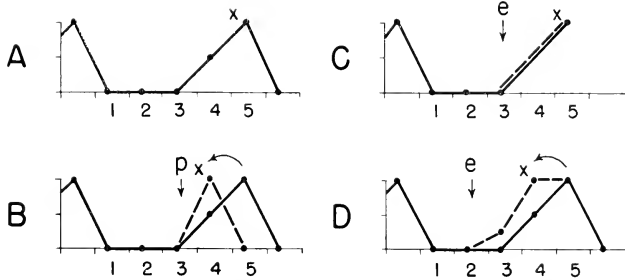

FIG. 8.7. Experimental modifications of the 5-day cycle in rats. Two units of the ordinate represent full vaginal estrus. Time in days on abscissa, each unit 24 hours (midnight to midnight). *x*, ovulation time; *p*, progesterone, usually 1 to 2 mg.; *e*, estradiol benzoate, standard dose 50  $\mu$ g. (From J. W. Everett, *Endocrinology*, **43**, 393, 1948.)

strates the existence of strain differences in the age factor. This probably explains the absence of luteinization in the experience of Lane (1935) and Merekel and Nelson (1940). Hollweg and Chamorro (1937) demonstrated the importance of the hypophysis in the response. When hypophysectomy was performed 2 days after injection of estrogen no corpora lutea developed, but hypophysectomy on the 4th day did not interfere with corpus luteum formation. The effect could be produced in 50-gm. rats with as little as 4  $\mu$ g. estradiol benzoate. Westman and Jacobsen (1938b) reported that transection of the hypophysal stalk less than 2½ days after injection prevented the reaction, but after that time the operation did not interfere. Bradbury (1947) assayed the gonadotrophin content of hypophyses of normal and castrated immature rats (30 to 32 days old at autopsy) 2 to 5 days after injection of estrogen or other steroids. These rats were apparently too young to form corpora lutea in response to the treatment, but marked interstitial-cell stimulation, indicative of LH (ICSH) activity, was observed as early as 96 hours. In the intact animals significant loss of potency occurred 72 to 96 hours after injection, in agreement with the hypophysectomy data of Hollweg and Chamorro (1937). In castrated rats, however, there was no loss of potency, thus suggesting that some ovarian factor in addition to estrogen is essential for stimulation of the hypophysis. It is unfortunate that the study was confined to animals too young to give the full response of luteinization.

Induction of ovulation in adult animals by estrogen was first reported by Hammond, Jr., Hammond and Parkes (1942) and by Hammond, Jr. (1945) in the anestrous ewe. Whereas the spontaneous occurrence of occult ovulation was approximately 5 per cent, injection of stilbestrol was followed by corpus luteum formation in 4 of 11 ewes, with recovery of ova in 3. Injection of stilbestrol di-*n*-butyrate was followed by corpus luteum formation in 5 of 6 ewes and ova were recovered in 3. The finding was confirmed by Casida (1946) who stated that in cycling ewes ovulation can be invoked by injection of diethylstilbestrol on the 4th day of the cycle, but not at other times. In 1947 Everett reported the induction of ovulation in pregnant rats within 40 hours after injection of estradiol benzoate (as little as 2 or 3  $\mu$ g.) or implantation of estradiol crystals or pellets. The response was not obtained in animals autopsied 24 hours after treatment nor in other animals hypophysectomized at 24 hours and autopsied the following day. In other studies with adult rats it was demonstrated (Everett, 1948) that in 5-day cyclic rats the injection of estrogen at mid-diestrus will regularly induce ovulation 24 hours earlier than expected (Figs. 8.7*D*, 8.8*F*). Persistent-estrous rats were refractory to estrogen in this respect.<sup>2</sup> Nevertheless, when such animals were made pseudo-pregnant by daily injection of progesterone.

<sup>2</sup> The tendency toward refractoriness of similar animals with respect to induction of estrous behavior had earlier been reported by Bofa, Blandau, Rundlett and Young (1941).

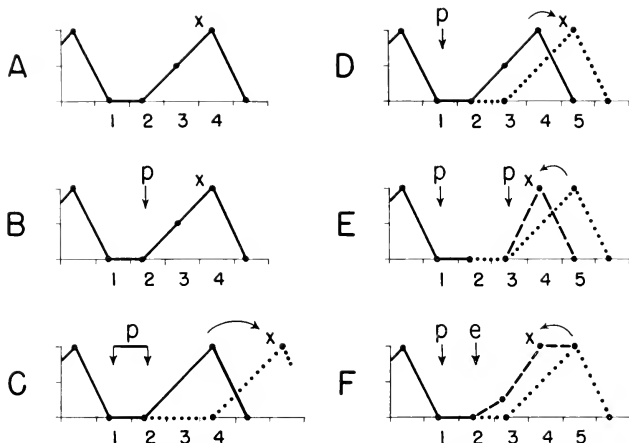

FIG. 8.8. Experimental modification of the 4-day cycle in rats. Same key as in Figure 8.7. Progesterone dosage 1.5 mg. per day. Artificial 5-day cycles in *D*, *E*, and *F* indicated by dotted lines and numbering. (From J. W. Everett, *Endocrinology*, **43**, 395, 1948.)

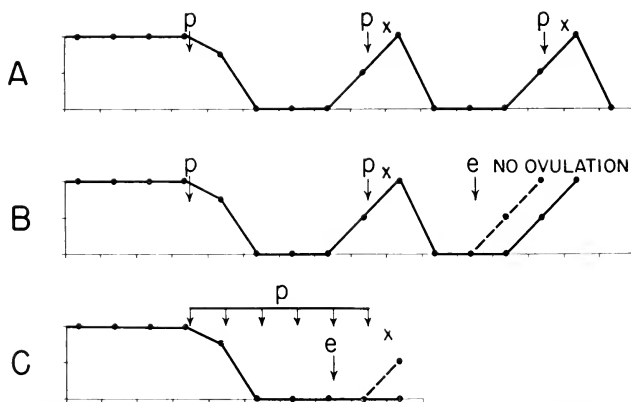

FIG. 8.9. Experiment with persistent-estrous rats. Units of ordinate and abscissa have same meaning as in Figure 8.7. *A*, Sequence of "progesterone cycles." Each dose of progesterone (*p*) is 1.0 mg. Ovulation (*x*) in about 70 per cent of the cycles. *B*, Progesterone cycle followed by unsuccessful attempt to induce ovulation by estrogen during the second cycle. *C*, Pseudo-pregnancy maintained by daily injection of 1.5 mg. progesterone. Ovulation induced by estrogen in several such cases. (From J. W. Everett, *Endocrinology*, **43**, 399, 1948.)

ovulation and corpus luteum formation were induced by estrogen (Fig. 8.9).

Early attempts to induce luteinization in the guinea pig with estrogen were unsuccessful (Dempsey, 1937; see Fig. 8.5f), but more recently Lipschutz, Iglesias, Bruzzone, Humerez and Peñaranda (1948) have shown by the use of intrasplenic ovarian autografts

that luteinization is a regular feature in experiments in which estrogen is administered systemically. Interestingly enough the implantation of estrogen pellets in or near the ovarian grafts had the contrary effect of preventing luteinization.

It was early reported that rabbits fail to ovulate in response to estrogen injection



(Bachman, 1936; Mazer, Israel and Alpers, 1936). Hisaw (1947) inferred that this is generally true for reflex ovulators. Nevertheless, it was found by Klein and Mayer (1946) and Klein (1947) that when pseudo-pregnant or pregnant rabbits were treated with estrogen and then mated, new ovulation resulted and new corpora lutea were formed, events that do not otherwise occur. The phenomenon was further explored by Sawyer (1949). Whereas untreated rabbits, unlike cats, do not ovulate in response to mechanical stimulation of the vagina, treatment with estrogen on the preceding 2 days results in a positive response to this stimulus. In fact, his later observations (1959) indicate that estrogen priming for a longer period (4 days) occasionally results in "spontaneous" ovulation, especially during the winter and spring.

In the anestrus cat, in the response to mechanical stimulation of the vagina, estrogen facilitates the ovulation of follicles primed with equine gonadotrophin (Sawyer and Everett, 1953).

Induction of ovulation by estrogen in primates remains to be demonstrated. It is of interest in this connection that Funnell, Keaty and Hellbaum (1951) observed in menopausal women an increased excretion of LH during estrogen therapy, in contrast to FSH excretion at other times. The general experience has been that injection of estrogen during the early part of the cycle significantly postpones the next expected ovulation and menstruation (monkey, Ball and Hartman, 1939; baboon, Gillman, 1942; human, Sturgis and Meigs, 1942; Brown, Bradbury and Jennings, 1948). Gillman reported that a single injection of estrogen precipitates widespread atresia of vesicular follicles. Brown and Bradbury (1947) reported preliminary data that in 4 of 6 women there was increased gonadotrophin excretion during the 24 hours following estrogen administration. They proposed that delay of ovulation by estrogen given early in the primate cycle may be the result of premature discharge of gonadotrophin before the Graafian follicle is competent. Sturgis and Meigs had suggested, on the contrary, that the estrogen suppresses hypophyseal function. D'Amour (1940), finding in urinary

excretion preceded the peak excretion of urinary gonadotrophin, postulated that the increase of estrogen stimulates the gonadotrophin release that is responsible for ovulation. O. W. Smith (1944) proposed that not estrogen itself, but some metabolite resulting from inactivation by the liver, is responsible for LH release. This interesting hypothesis has not been substantiated.

## 2. Gestagens

Suppression of estrus and ovulation by functional corpora lutea, suggested by Beard (1898), was experimentally demonstrated in the guinea pig by Loeb (1911). It is now well established in several species that removal of the corpora lutea results in early resumption of estrus and ovulation (see p. 506), and that administration of progesterone suppresses these events. There is considerable evidence favoring the view that the primary effect is to selectively suppress the secretion of LH. Dempsey (1937) noted that in guinea pigs receiving daily injection of progesterone (50  $\mu$ g.) all stages of follicle development proceeded except the maturation enlargement that heralds LH release (Fig. 8.5). Astwood and Fevold (1939) and Cutuly (1941b) found similar results in rats. Essentially the same phenomenon has been noted in sheep by Dutt and Casida (1948). Bradbury (1947) reported that in immature rats the injection of progesterone at the time of estrogen injection prevented the release of gonadotrophin (LH?) which otherwise followed estrogen injection by 72 to 96 hours. In ovariectomized guinea pigs containing intrasplenic autografts, preparations in which luteinization can be induced by estrogen (see above), the simultaneous administration of gestagens prevented this action (Lipschutz, Iglesias, Humerez and Peñaranda, 1948; Iglesias, Lipschutz and Guillelmo, 1950; Mardones, Bruzzone, Iglesias and Lipschutz, 1951). Mardones and co-workers also made the interesting observation that among several steroids having progestational activity, "antiluteinizing activity is not concomitant with, or subordinated to" the former function. Proportionately very large amounts of ethinyl testosterone and ethinyl- $\Delta^2$ -androstenediol exhibited very little antiluteinizing activity. There is evi-

dence in mice (Selye, 1939) that suppression of FSH secretion may occur when as much as 1 mg. of progesterone is injected daily. Alloiteau (1954) believes that this also occurs in the rat, although Cutuly (1941b) found only slight evidence of FSH suppression when as much as 6 mg. progesterone were given daily for several weeks.

So much emphasis has been placed on the suppressing effect of progesterone that its facilitating actions were recognized only in recent years. The first indication that progesterone can promote ovulation and corpus luteum formation in mammals was encountered in a study of persistent-estrous rats (Everett, 1940a, b). Daily injection of 0.25 to 1.0 mg. caused the prompt interruption of the state of persistent follicle and the resumption of outwardly normal cycles. Corpora lutea were formed in approximately 70 per cent of these cycles.<sup>3</sup> The effect was obtained not only in older rats in which persistent estrus had developed spontaneously, but also in young rats in which the condition had been induced by continuous illumination. The dose level employed is below that required to suppress cycles in normal rats (1.5 mg. daily; Phillips, 1937). Subsequently, it was found (Everett, 1943) that the daily injection could be avoided if a single "interrupting" dose was given, followed by a single injection during proestrus or early estrus of each recurrent cycle (Fig. 8.9.1). The histologic appearance of the ovaries reverted toward the normal after a succession of "progesterone cycles" and, significantly, the interstitial-cell nuclei were "repaired." Attempts in normal rats to invoke ovulation earlier than the expected time were successful in the 5-day cycle (Figs. 8.7B, 8.8E). Injection of from 0.5 mg. to 2 mg. on the "third day of diestrus" regularly (4 mg. occasionally) invoked ovulation during the coming night (Everett, 1944a, 1948) unless the treatment was given *too late in the day* (Everett and Sawyer, 1949; see discussion on p. 526 regarding the diurnal rhythm and ovulation). Attempts to advance ovulation in the 4-day cycle were unsuccessful, possibly because the follicles were not competent or the animals<sup>4</sup>

intrinsic estrogen levels were not elevated sufficiently early.

Ovulation induced by progesterone has been reported in several species. A direct action on the excised ovary of the toad *Xenopus* was early demonstrated by Zwarenstein (1937) but such action is apparently not found in higher vertebrates. In the domestic hen injection of progesterone can invoke ovulation several hours ahead of schedule (Fraps and Dury, 1943; Rothchild and Fraps, 1949). Pfeiffer (1950) observed new corpora lutea in 10 rhesus monkeys treated with progesterone during presumptive anovulatory cycles of the summer months. Similar attempts have been made in women (Rothchild and Koh, 1951); although there were said to be definite indications of induced ovulation, the evidence is equivocal. On the other hand, a report (Hansel and Trimberger, 1952) states that in heifers the injection of small doses of progesterone (5 to 10 mg.) at the beginning of estrus significantly advances ovulation time. This is in contrast with the inhibitory effect of larger doses (50 mg.) beginning before the onset of estrus (Ulberg, Christian and Casida, 1951). Even in the rabbit (Sawyer, Everett and Markee, 1950), spontaneous ovulation was noted in 4 of 10 animals after combined estrogen and progesterone injection.

From certain of the foregoing statements it may be inferred that whether suppression or stimulation follows administration of progesterone depends critically on the time of injection, on the amount given, on the status of the ovary, and probably on a priming action of estrogen. A significant illustration of the critical nature of the time factor in rats is given by the experiments represented in Figure 8.8C' and E. If after the first injection of 1.5 mg. progesterone on the first day of diestrus, a second injection follows in about 24 hours, the impending estrus and ovulation are retarded an additional 24 hours. However, if the second injection is given 48 hours after the first, the impending estrus and ovulation are advanced. Evidence of the synergistic action of estrogen and progesterone in evoking ovulation is given by the experiments represented in Figure 8.9B and C, Sawyer (1952)

<sup>3</sup>Marvin (1947) described a similar result with desoxycorticosterone acetate.

investigated the synergism in rabbits. Employing estrogen-primed animals, he found that ovulation was facilitated when progesterone was injected less than 4 hours before either mating, mechanical stimulation of the vagina, or intravenous injection of copper acetate. Inhibition was obtained when progesterone was injected 24 hours before such stimulation, thus confirming the often-cited observations of Makepeace, Weinstein and Friedman (1937) and Friedman (1941) that progesterone inhibits ovulation in rabbits.

Preovulatory secretion of gestagens now seems likely. Morphologic luteal changes in preovulatory follicles are considered in the chapter on the ovary. A variety of evidence in primates indicates that progestational changes in the endometrium begin before ovulation (Bartelmez, Corner and Hartman, 1951). Several workers have reported the excretion of small amounts of pregnanediol during the follicular phase of the human cycle (Wilson, Randall and Osterberg, 1939; Smith, Smith and Schiller, 1943; Davis and Fugo, 1948). Determination of plasma progesterone in women by the Hooker-Forbes test indicates the presence of significant amounts a day or two before a major rise in basal body temperature (Forbes, 1950). In monkeys a small quantity (ca. 0.5 to 1.0  $\mu\text{g}$ . per ml.) was detected between the 4th and 9th days, rising in the 10- to 15-day period to concentrations of 2 to 6  $\mu\text{g}$ . per ml. (Forbes, Hooker and Pfeiffer, 1950; Bryans, 1951). In both species a transient decline seems to intervene before the marked rise to still higher concentrations during the luteal phase. In the rat, Constantiniides (1947) studied the stromal nuclei of the endometrium at different stages of the cycle and found that by the Hooker-Forbes criteria there is evidence of progesterone secretion during proestrus. Astwood (1939) on the basis of water content of rat uteri concluded that progesterone secretion begins with proestrus. In the rabbit, Forbes (1953) assayed peripheral blood at various intervals after mating or gonadotrophin injection. Although no progesterone was detectable in controls, significant amounts appeared an average of 97 minutes after mating and 66 minutes after gonado-

trophin injection. As much as 2.5  $\mu\text{g}$ . per ml. was found during the first 8 to 10 hours, although marked fluctuations were noted from time to time in the blood of individual animals. Verly (1951) reported that soon after mating the urine of rabbits contains significant amounts of pregnanediol.

It has become customary to state that the gestagen that appears during the follicular phase of the cycle is probably formed by the maturing follicle itself. Indeed, assays of fluid from Graafian follicles and cysts have indicated the presence of the hormone (Duyvené de Wit, 1942; Hooker and Forbes, 1947; Edgar, 1952, 1953). However, if it is to take part in the release of ovulating hormone gestagen must be secreted earlier than preovulatory maturation. For this also there is some evidence. Two reports cited above indicate that in monkeys, at least, there is a detectable amount present in the blood during the early follicular phase. The known fact that a waning corpus luteum favors the experimental induction of estrus and/or ovulation in sheep and cattle (Hammond, Jr., 1945; Robinson, 1951; Marden, 1952) is suggestive. Although Hammond, Jr., Hammond and Parkes (1942) tested this possibility by progesterone substitution with negative results, the amount given may have been too small, as Robinson suggested. A waning corpus luteum in the rat favors ovulation, as disclosed in persistent-estrous animals in which pseudopregnancy had been induced (Everett, 1939). Each of three pseudopregnancies was followed by a short cycle before the animals returned to persistent estrus.

In the course of studies growing out of this observation evidence was advanced (Everett, 1945) which indicated that corpora lutea of the normal rat are not wholly inactive during the short cycle. Transient depletion of cholesterol was observed in such corpora lutea during the proestrus that followed their formation. This implies a transient increase of luteotrophin secretion. Significantly this occurs *before* the release of LH. It is this writer's opinion that gestagen from such sources is not essential for the induction of ovulation but that it does facilitate the action of estrogen.

C. ROLE OF THE NERVOUS SYSTEM  
IN OVULATION

Historically, the fact of neural control of reflex ovulation has been recognized in the rabbit for many years. The comparable role of the nervous system in spontaneous ovulation, on the other hand, has more recently become apparent. It now seems justifiable and useful to postulate in the hypothalamus of reflex ovulators and spontaneous ovulators alike the existence of a mechanism that is peculiarly concerned with release of ovulating hormone. Whether it consists in a discrete anatomic entity is immaterial for the present.

The suggestion has been made that the outstanding difference between reflex and spontaneous ovulation may be in the kinds of afferent impulses that most readily excite the hypothalamus (Sawyer, Everett and Markee, 1949). The difference is not absolute, for spontaneous ovulation has been induced in rabbits by estrogen-progesterone injection (see p. 519) and reflex ovulation has been demonstrated under special circumstances in rats (Dempsey and Searles, 1943; Everett, 1952a) and cattle (Marion, Smith, Wiley and Barrett, 1950). The random distribution of reflex ovulators and spontaneous ovulators among mammalian orders becomes more understandable if one assumes that dual controls are widely represented and that special adaptations favor one or the other in given species.

The ovulation reflex in rabbits is apparently initiated by afferent impulses of multiple origin, among them not only impulses from the genitalia, but also proprioceptive impulses from muscles that are utilized in coitus. Brooks (1937, 1938) found that, although the sacral segments of the spinal cord and the abdominal sympathetic chains could be eliminated without preventing ovulation, the lumbar cord must remain. Only by paralysis of the lower half of the body so that the female could not take part in coitus was ovulation prevented. The neocortex could be removed, together with the olfactory bulbs, labyrinths, auditory apparatus and eyes without impairing the ovulation response. Even after complete decortication, ovulation followed coitus in 1 out of 3 rabbits. It must be admitted, how-

ever, that, although various parts of the nervous system may thus be eliminated without changing the end result, some of them may normally play a considerable role. With little question, direct stimuli from the genitalia play a part in the natural reflex. Under certain experimental conditions detectable electrical activity in the rabbit rhinencephalon is associated with the induction of ovulation (Sawyer, 1955). Electrical stimulation of the amygdala will induce ovulation in rabbits and cats (Koikegami, Yamada and Usei, 1954; Shedy and Peele, 1957).

In rats, Davis (1939) found that removal of the neocortex had no effect on the estrous cycle and ovulation. Removal of portions or of the entire sympathetic chains of rats likewise did not interfere with ovulation (Bacq, 1932). Bunn and Everett (1957) reported ovulation in constant-estrous rats after electrical stimulation of the amygdala.

The importance of the dorsal thalamus is unknown. The reticular activating system has been implicated as a component of the ovulation mechanism (Sawyer, 1958), but the manner of its contribution is not clear. There is little question, on the other hand, of the indispensability of the hypothalamus and its neurovascular connection to the adenohypophysis through the median eminence and the hypophysal portal veins.

Although the observation by Marshall and Verney (1936) that ovulation can be induced by passing an electric current through the heads of estrous rabbits hardly limited the effect to the hypothalamus itself, it was later shown that more localized electrical stimuli applied to certain hypothalamic regions are consistently effective (preoptic area, Haterius, 1937; Christian, 1956; posterior hypothalamus or tuber cinereum, Harris, 1937, 1948b; tuber cinereum or adjacent hypothalamic areas, Markee, Sawyer and Hollinshead, 1946; medial hypothalamus from preoptic area to mammillary bodies, Kurotsu, Kurachi and Ban, 1950; Kurotsu, Kurachi, Tabayashi and Ban, 1952).

Although hypothalamic lesions, both natural and experimental, have frequently been reported to interfere with normal

sex function (see Harris, 1948a, 1955, for references), the majority of these reports do not apply to the question at issue—control of ovulation. When ovarian atrophy occurs, as it frequently did in these cases, it reflects a profound depression of gonadotrophin secretion and absence of competent follicles. However, Dey, Fisher, Berry and Ramson (1940) and Dey (1941, 1943) found in guinea pigs that gross bilateral electrolytic lesions placed in the rostral hypothalamus resulted in persistent follicles with continuous estrogen secretion. Similar results were obtained in rats by Hillarp (1949) when small bilateral electrolytic lesions were placed in the anterior hypothalamic area near the paraventricular nuclei or between this region and the median eminence. Greer (1953) reported continuous estrus in rats after placing certain small lesions in the ventromedial nucleus, provided they were bilateral. There was no correlation with obesity. There are at least four significant points in common among these several ablation experiments. (1) The effective lesions were rostrally placed and either were limited to or included the medial group of nuclei. (2) The tuber cinereum, median eminence, and stalk connection to the hypophysis were intact. (3) Although development of competent follicles was not evidently impaired, estrogen secretion became continuous instead of cyclic. (4) The proper impetus for release of ovulating hormone from the hypophysis was absent. It would be most instructive to learn whether ovulation can be invoked in such animals by reflex stimulation or by direct electrical stimulation of the tuber. Alloiteau and Courvoisier (1953) reported that rats in constant estrus as a result of hypothalamic lesions did not undergo pseudopregnancy after stimulation of the cervix uteri. This observation, confirmed by Greer (1953), could be construed as indirect evidence of failure of reflex ovulation, for Greer regularly obtained pseudopregnancy by cervical stimulation, once corpora lutea had been formed by other means.

Other findings by Greer are important because of their bearing on the location and character of a presumptive ovulation center. Although the onset of persistent estrus after

making the lesions was sometimes almost immediate (following a brief anestrus interval), in other cases it was preceded by several apparently normal cycles. In any event, once the condition had become established, the daily injection of small amounts of progesterone brought about the recurrence of cycles and corpus luteum formation. In about half of the cases these cycles continued for awhile after withdrawal of treatment, whereas in the remainder there was a prompt return to persistent estrus. Essentially the same results were reported by Alloiteau (1954), and the observations suggest that the areas involved in such lesions may be of only secondary importance.

The use of radioactive phosphorus for estimating energy exchange in tissues affords a different approach to the problem of neural control of ovulation (Borell, Westman and Öström, 1947, 1948). This method has the virtue that the experimental subject remains undamaged until injection of  $P^{32}$  compounds 30 minutes before the end of the experiment. In rabbits there is a marked increase in phosphorus turn-over in the tuber cinereum within 2 minutes post coitum, and continuing for about an hour thereafter (Table 8.1). The adenohipophysis shows increasing activity during the first 10 minutes which reaches a peak at about 1 hour and then regresses somewhat, although it remains relatively high for 24 hours. Response of the ovary to gonadotrophin release is marked by a rapid rise during the second half-hour and another pronounced increase near the time of ovulation. In rats, at various stages of the estrous cycle, phosphorus exchange in both tuber cinereum and adenohipophysis is maximal during proestrus. In the ovary high values were reported during diestrus and proestrus, somewhat lower values during estrus and metestrus.

Possibly correlated with the above information is the observation (Gitsch, 1952b) that in rats the acetylcholine (ACh) content of the tuberal region becomes elevated during proestrus and estrus. It is said that ACh synthesis requires high energy phosphate (see Bain, 1952). Further investigation by Gitsch (1952a) and Gitsch and Reitingger (1953) revealed that ACh

TABLE 8.1  
*Sequence of events in rabbit ovulation*

Time (hr.:min.)	Central Nervous System	Hypophysis	Ovary	Circulating Blood
30 sec.	Barbiturate-sensitive and atropine-sensitive mechanisms <sup>1</sup>			
<2 min.	↑ Phosphorylation in tuber cinereum <sup>2</sup>			
10 min.	↓ Phosphorylation in tuber cinereum <sup>2</sup>	↑ Phosphorylation <sup>2</sup>		
30 min.	↑ Phosphorylation in tuber cinereum <sup>2</sup>	Release of LH ca. 20 per cent. <sup>6</sup> Hypophysectomy prevents ovulation <sup>1, 12</sup>	↑ Phosphorylation <sup>2</sup>	Animal may be bled and transfused without preventing ovulation <sup>12</sup>
60 min.	↑ Phosphorylation in tuber cinereum <sup>2</sup>	Release of LH now sufficient for ovulation. <sup>1, 12</sup> Phosphorylation at peak <sup>2</sup>		
75-90 min.				Bleeding and transfusion now <i>prevent</i> ovulation <sup>12</sup>
1½-2 hrs.			↑ Liquor folliculi. Tetrads in egg nuclei <sup>8</sup>	Progesterone detectable <sup>5</sup>
3-5 hrs.			Cholesterol depletion in interstitial gland. <sup>3</sup> Egg nucleus migrates, membrane dissolves. <sup>8-11</sup> Prominent corona <sup>8</sup>	
6-7 hrs.			Liquor folliculi increasingly viscous <sup>8</sup>	Increased estrogen (endometrial hyperemia) <sup>7</sup>
7-8 hrs.			First polar body <sup>8</sup>	
9-11 hrs.			Marked swelling of follicles. Thecal hypertrophy. <sup>1, 10</sup> hyperemia	
10-11 hrs.			OVULATION. <sup>11</sup> ↑ Phosphorylation <sup>2</sup>	

<sup>1</sup> Asdell, 1946.

<sup>2</sup> Borell, Westman and Örström, 1947. Claesson and Hillarp, 1947a.

<sup>3</sup> Fee and Parkes, 1929.

<sup>4</sup> Forbes, 1953.

<sup>5</sup> Hill, 1934.

<sup>6</sup> Sawyer, Markee and Hollinshead, 1947.

<sup>7</sup> Pineus and Enzmann, 1935.

<sup>8</sup> Sawyer and associates, 1947, 1949, 1950.

<sup>9</sup> Walton and Hammond, 1928.

<sup>10</sup> Waterman, 1943.

<sup>11</sup> Westman and Jacobsohn, 1936.

in the rat hypothalamus is increased also by administration of estrogen or by castration, conditions that similarly increase phosphorus exchange (Borell and Westman, 1949). The ACh content is depressed during pregnancy or when the rat has been injected with progesterone. It is also lowered by Pentothal anesthesia, a matter of interest in relation to the fact that the barbiturates suppress ovulation (see p. 526).

The location and measurement of activity in discrete nuclei and pathways are largely in the future, although a beginning has been made in the rabbit, cat, rat, and mouse. Sawyer (1955) found in rabbits, after the combined administration of pentobarbital intravenously and histamine by way of the 3rd ventricle, that there was associated with induction of ovulation a characteristic change in intrinsic electrical activity of the rhinencephalon, extending into the preoptic area. If the olfactory tracts were cut, however, this activity could not be elicited and ovulation failed. According to Porter, Cavanaugh and Sawyer (1954), vaginal stimulation of estrous cats caused altered electrical activity in two hypothalamic regions: (1) in the lateral hypothalamic area at the anterior tuberal level during stimulation and for 15 to 45 seconds afterward; and (2) in the anterior hypothalamic area near the medial forebrain bundle, where response was delayed as much as 5 minutes after stimulation. According to a preliminary account (Critchlow and Sawyer, 1955) in curarized, proestrous rats, there were periods lasting approximately 20 minutes in the midafternoon, during which altered electrical activity appeared differentially in the preoptic area or anterior hypothalamus.

Another approach to localization has been described by Hertl (1952, 1955). On the proposition that increased function of particular cells is reflected by increased volume of their nuclei, cell nuclear volumes were measured in hypothalamic nuclei of female mice at different stages of the estrous cycle. During proestrus and estrus there was said to be a functional edema in hypothalamic nucleus 20 of Grünthal (possibly the pars posterior of the ventromedial nucleus of Krieg) and to lesser extent in nucleus 16 (Nuel, arenatus).

### 1. *The Hypophyseal Portal Veins and the Chemotransmitter Hypothesis*

As noted elsewhere, hypothalamic control of the pars distalis is probably mediated by the hypophyseal portal circulation. Evidence for this has been especially convincing with respect to control of ovulation, although indications are that other phases of the cycle are also regulated by this means. Pertinent data from numerous transplantation and stalk-section experiments may be summarized by the following statement. Aside from a questionable grafting experiment (2 rats) reported by May (1937), in no case has ovulation or luteinization been reported in the absence of vascular linkage of the pars distalis with the median eminence; on the other hand, ovulatory cycles have often been quickly restored when the gland has been revascularized by the portal vessels (see especially, Harris, 1950a; Harris and Jacobsen, 1952; Nikitovitch-Winer and Everett, 1957, 1958b).

Although the importance of local vasomotor regulation in the stalk vessels remains to be evaluated (Green, 1951), there is extensive support for the hypothesis that ovulatory release of gonadotrophin is invoked by a chemotransmitter (Harris, 1948a, 1955). If one accepts the prevailing opinion that nerve fibers entering the pars distalis are too few to account for its secretomotor control and that the flow of blood in the hypophyseal portal vessels is toward the gland (Wislocki and King, 1936; Green, 1947; Green and Harris, 1947, 1949; Barnett and Greep, 1951; Landsmeer, 1951; McConnell, 1953; Xuereb, Prichard and Daniel, 1954; Worthington, 1955), the plausibility of the chemotransmitter hypothesis becomes inescapable.<sup>4</sup>

Evidence that the transmitter may be

<sup>4</sup> For a dissenting view, see Zuckerman (1952). Reference should also be made to the hypothesis formulated by Spatz (1951) and associates (see Nowakowski, 1950, 1952). They postulated that a descending pathway in the spinal cord is the connecting link between hypothalamus and ovaries. With respect to ovulation, this is clearly denied by the fact that local stimulation of the hypothalamus provokes ovulation in rabbits in which the thoracic spinal cord has been transected (Christian, Markee and Markee, 1955).

adrenergic was presented by Markee, Sawyer and Hollinshead (1948), who provoked ovulation in rabbits by instilling epinephrine directly into the pars distalis. Detailed experiments supporting this were fully reviewed by Markee, Everett and Sawyer (1952). In discussion following that paper, Sawyer reported the induction of ovulation in rabbits by the injection into the third ventricle of either epinephrine or norepinephrine, and suggested that the latter is "more closely related to the natural mediator than is epinephrine." Donovan and Harris (1956), from studies in which the rabbit hypophysis was slowly infused *in situ* with solutions of epinephrine or norepinephrine, concluded that neither substance is the agent in question, and that the positive results of Markee, Sawyer and Hollinshead (1948) were the effects of low pH and not of the drugs *per se*. Proof of the negative is elusive, however, and one must note that Donovan and Harris did not meet the conditions of timing and drug concentration that obtained in the earlier work.

Intravenous injection of Dibenamine or its congener, SKF-501,<sup>5</sup> will usually prevent ovulation in rabbits when injection is completed within 1 minute after coitus (Sawyer and associates, 1947-50). On the other hand, when injection is delayed until 3 minutes or later, ovulation is unaffected. The nonadrenergic hydrolysis product of Dibenamine, 2-dibenzylaminoethanol, does not have the blocking action, although its central excitatory powers are much like those of the parent substance. The failure of blockade by Dibenamine, if injection is withheld for 3 minutes, demonstrates that the drug does not interfere with the actual discharge of ovulating hormone into the blood stream, for that process requires about an hour (Fee and Parkes, 1929; Westman and Jacobsen, 1936). The Dibenamine-sensitive mechanism thus serves as a trigger, the gland being adequately stimulated within 1 or 2 minutes post coitum. This estimate is in remarkable agreement with the earlier mentioned observations on

phosphorus exchange in the tuber cinereum and hypophysis (p. 521, and Table 8.1).

A mechanism that is subject to blockade by atropine or Banthine<sup>5</sup> evidently precedes the Dibenamine-sensitive process—temporally if not anatomically. To accomplish blockade in rabbits, these anticholinergic drugs must be injected intravenously within about 30 seconds after coitus (Sawyer and associates, 1949-1951). It should be recalled that Foster, Haney and Hisaw (1934) reported failure of ovulation in several rabbits treated with small amounts of atropine before mating. Makepeace (1938), however, was unable to confirm the effect with somewhat larger doses and the former observation was forgotten.

A seemingly crucial experiment devised by Sawyer gives conclusive evidence that the atropine-sensitive process is antecedent to the Dibenamine-sensitive one. It was based on two facts: (1) intravenous injection of nearly lethal doses of epinephrine does not induce ovulation in estrous rabbits, and (2) atropine protects rabbits against fatal pulmonary edema after injection of large amounts of epinephrine. In rabbits protected by atropine in dosage that was also sufficient to block the ovulation reflex, the injection of *twice-lethal* doses of epinephrine caused ovulation or significant degrees of follicle maturation in 5 of 7 cases. These effects were not found in rabbits protected by Dibenamine. Supporting evidence was adduced by Christian (1956) who found that atropine would not prevent ovulation in response to electrical stimulation of the medial preoptic area or adjacent parts of the hypothalamus, whereas in a significant number of such rabbits ovulation was blocked by SKF-501.

Extension of the blocking experiments to the rat, as an example of a spontaneous ovulator, disclosed that in this species also ovulation can be blocked by Dibenamine, SKF-501, atropine, and Banthine, when the injections are appropriately timed with respect to the stage of the cycle and time of day (Sawyer, Everett and Markee, 1949; Everett, Sawyer and Markee, 1949; Everett and Sawyer, 1949, 1950, 1953; see p. 526). Furthermore, blockade of both estrogen-induced and progesterone-induced ovulation

<sup>5</sup> Dibenamine is *N,N*-dibenzyl- $\beta$ -chloroethylamine. SKF-501 is *N*-(9-fluorenyl)-*N*-ethyl- $\beta$ -chloroethylamine hydrochloride. Banthine is  $\beta$ -diethylaminoethyl-xanthene-9-carboxylate methobromide.



was accomplished with either Dibenamine or atropine. Neither agent, however, prevented ovulation after injection of sheep hypophyseal LH. A report by Hansel and Trimberger (1951) stated that in cattle a significant delay of ovulation (as great as 72 hours) followed atropine administration. In control experiments the simultaneous injection of atropine and human chorionic gonadotrophin was followed by ovulation slightly earlier than the normally expected time. Treatments were begun 1 to 5 hours after the onset of estrus. This work was confirmed and extended by Hough, Beardon and Hansel (1955). In the hen, blockade of ovulation, normal or induced by progesterone, has been reported after administration of Dibenamine, Dibenzylamine, SKF-501 or atropine (Zarrow and Bastian, 1953; van Tienhoven, 1955). According to van Tienhoven, the drugs did not interfere with the ovulating action of extrinsic gonadotrophin.

It is important that the same drugs will block ovulation in both rabbits and rats (Table 8.2). Of equal significance is the fact that several agents that are ineffective in rabbits are also ineffective in rats (notably 2-dibenzylaminoethanol, the imidazoline adrenolytic drugs, and the ganglion blocking agents). These considerations are interpreted to mean that spontaneous ovulation is invoked by neurohumoral mechanisms that are very like those in the reflex ovulation of rabbits.

The suggestion that the blocking effects might result from nonspecific stress, causing the hypophysis to be so actively secreting ACTH that gonadotrophin secretion is interfered with (Dordoni and Timiras, 1952), is clearly denied by several facts. (1) In the rabbit studies, none of the various agents prevented ovulation when injected more than a minute post coitum. (2) In one study (Sawyer, Markee and Everett, 1950b) ovulation was actually induced by the intravenous injection of "lethal" doses of epinephrine when the animals were protected by atropine. (3) In rats ovulation is unaffected by massive intravenous doses of either the imidazoline drugs or 2-dibenzylaminoethanol in amounts known to be stressing (Sawyer and Parkerson, 1953).

TABLE 8.2  
*Pharmacologic Agents and Blockade of Ovulation*

	Rabbit	Rat	Cow	Hen
<b>ANTADRENERGICS</b>				
$\beta$ -Haloalkylamines				
Dibenamine	B <sup>1</sup>	B <sup>1</sup>		B <sup>2</sup>
SKF-501	B <sup>1</sup>	B <sup>1</sup>		B <sup>3</sup>
Dibenzylamine				B <sup>2</sup>
Imidazolines				
Priscoline	0 <sup>1</sup>	0 <sup>1</sup>		
Regitine	0 <sup>1</sup>	0 <sup>1</sup>		
Yohimbine		2 <sup>4, 5</sup>		
<b>ANTICHOLINERGICS</b>				
Atropine	B <sup>1</sup>	B <sup>1</sup>	B <sup>6</sup>	B <sup>3</sup>
Banthine	B <sup>1</sup>	B <sup>1</sup>		
<b>ANTIHISTAMINICS</b>				
Neo-antergan	0 <sup>1</sup>			
<b>GANGLION BLOCKERS</b>				
Tetraethylammonium	0 <sup>1</sup>	0 <sup>1</sup>		
SC-1950	0 <sup>1</sup>			
<b>BARBITURATES</b>				
Nembutal	B <sup>1</sup>	B <sup>1</sup>		F <sup>7</sup>
Dial		B <sup>1</sup>		F <sup>7</sup>
Ipral		B <sup>1</sup>		F <sup>7</sup>
Amytal		B <sup>1</sup>		
Barbital		B <sup>1</sup>		B <sup>7</sup>
Phenobarbital		B <sup>1, 8</sup>		B <sup>7</sup>
Proninal		B <sup>9</sup>		
<b>OTHERS</b>				
Morphine		B <sup>10</sup>		
Procaine, locally near tuber		B <sup>11</sup>		
Procaine, systemically	0 <sup>1</sup>			
Chlorpromazine		B <sup>12</sup>		
Reserpine		B <sup>13</sup>		
Ether		B <sup>14</sup>		
2,4-Dinitrophenol		B <sup>15</sup>		

<sup>1</sup> Sawyer and associates, 1947-1951; Everett and associates, 1949-1950; Christian, 1956; and see present text.

<sup>2</sup> van Tienhoven, 1955; van Tienhoven, Nalbandov and Norton, 1954.

<sup>3</sup> Zarrow and Bastian, 1953.

<sup>4</sup> Fugo and Gross, 1942.

<sup>5</sup> Sulman and Black, 1945.

<sup>6</sup> Hansel and Trimberger, 1951; Hough, Beardon and Hansel, 1955.

<sup>7</sup> Fraps and Case, 1953.

<sup>8</sup> Döring and Göz, 1952.

<sup>9</sup> Westman, 1947.

<sup>10</sup> Barraclough and Sawyer, 1955.

<sup>11</sup> Westman and Jacobsohn, 1942.

<sup>12</sup> Barraclough, 1956.

<sup>13</sup> Barraclough, 1955.

<sup>14</sup> Unpublished. Temporary, during deep anesthesia.

<sup>15</sup> Unpublished. ED<sub>50</sub>: 25 mg. per kg. subcutaneously.

Key: B = Blockade.

0 = No blockade.

I = Ovulation induced by the drug.

Nor is it influenced by severe trauma, heat, cold, or formalin injection coincident with the known "critical period" (Everett, unpublished).

### 2. Central Depressants and Ovulation

Reported evidence of a blocking action of barbiturates on ovulation traces back to experiments by Westman (1947) who injected female rats with Prominal twice daily for 3 weeks. Approximately 30 per cent of these rats experienced prolonged vaginal estrus and had ovaries containing only follicles at the end of the experiment. Almost identical results were reported by Döring and Göz (1952) when rats were treated daily with phenobarbital. The agreement is not unexpected in view of the fact that in the body Prominal is quickly demethylated to phenobarbital. It was shown by Everett and Sawyer (1950) that when administration of barbiturates to rats is critically timed with respect to stage of the cycle and the time of day, blockade of ovulation can be accomplished at will in short-term experiments (Fig. 8.10). Chronic administration introduces considerable uncertainty for reasons that are not yet clear (Everett, 1952b). In the rabbit, the rapid intravenous injection of pentobarbital or Pentothal, within as short a time as 12 seconds after coitus, generally failed to block ovulation (Sawyer, Everett and Markee, 1950). However, it was later shown that barbiturate anesthesia will prevent the ovulation that is otherwise caused in the estrogen-primed rabbit by mechanical stimulation of the vagina, the anesthesia being induced in advance of the stimulation (unpublished).

Other central depressants reported to block ovulation in the rat are morphine, reserpine, chlorpromazine (Barraclough and Sawyer, 1955; Barraclough, 1955, 1956), and even meprobamate acting synergistically with an anticholinergic drug (Gitsch, 1958). Special interest attaches to the morphine work, in that amenorrhea and sterility often accompany morphine addiction in the human female. Related studies (Sawyer, Critchlow and Barraclough, 1955), in which recordings were made of electrical activity in various regions in the brain,

demonstrated in rats that morphine acts much like the barbiturates in depressing activity in the reticular activating system. The effect was also shown by atropine, in doses that would block ovulation. The inference is that all three agents block by striking at the same central elements of the LH-release apparatus.

An interesting peculiarity of domestic hens with respect to barbiturates was encountered by Fraps and Case (1953), who noted that pentobarbital induces ovulation prematurely, and that pentobarbital and progesterone supplement each other in this capacity. Although these developments may represent pharmacologic curiosities limited to the bird, the possibility should be seriously considered that similar effects may occur in other animals. In fact, pentobarbital in rabbits facilitates the release of hypophysial gonadotrophin in response to intraventricular injection of histamine, seemingly by an effect in the rhinencephalon (Sawyer, 1955).

### 3. The Central Nervous System as a Timing Mechanism for Ovulation

In the rat and the hen and probably many other species the pro-ovulatory excitation of the hypophysis is dependent in large measure on time of day.

In the rat, the blocking agents have served to delimit a critical period on the day of proestrus, before which ovulation can be blocked and after which it will occur in spite of injection of the blocking agent. Under controlled illumination for 14 hours daily, this critical period extends from about 2 p.m. to 4 p.m. Administration of either atropine or pentobarbital at 2 p.m. consistently blocks ovulation (Fig. 8.10), whereas injections later in the period are progressively less effective (Everett and Sawyer, 1950, 1953; Everett, 1956b). Such predictability of the hour of pituitary activation is, in itself, evidence of a relationship between this event and diurnal physiologic rhythms.

Further evidence is seen in the sequelae of pentobarbital injection (Fig. 8.11). Repetition at 2 p.m. on successive days results in a follicular cycle and prolonged vaginal estrus with eventual atresia of all

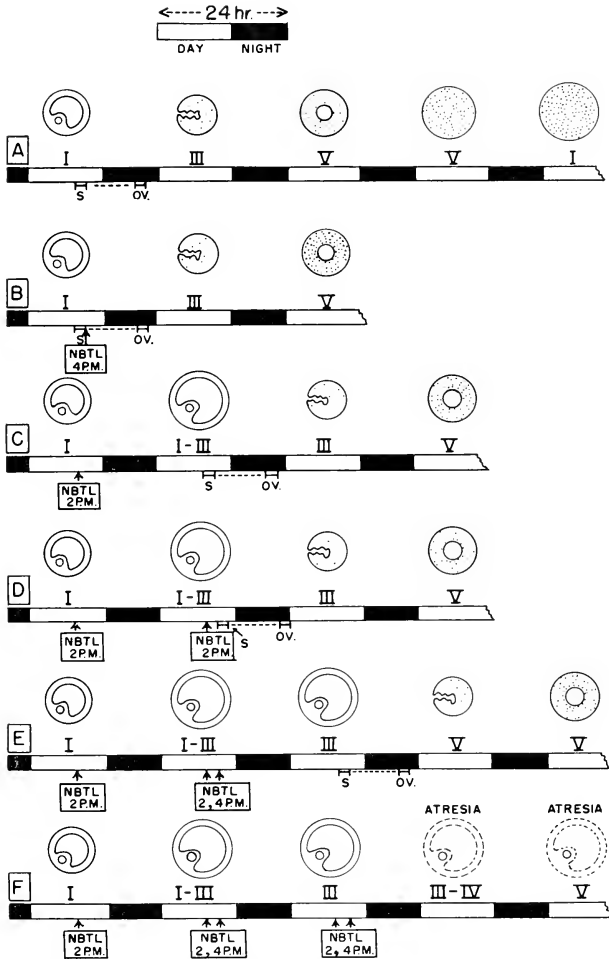

FIG. 8.10. Demonstration of 24-hour periodicity in the luteinizing hormone-release apparatus of female rats (Vanderbilt strain, 4-day cycle, controlled lighting: 14 hours per day). Schematic representations of the normal cycle (A) and of characteristic results of different regimes of Nembutal treatment (B to F). Vaginal stages indicated by Roman numerals over each time scale; symbols above these show the corresponding follicle and corpus luteum stages. The device marked S defines the "critical period," the time limits of pituitary activation as experimentally determined (Fig. 8.11). OV indicates normal ovulation time in A and estimated ovulation time elsewhere. NBTL indicates intraperitoneal injection of Nembutal. (From J. W. Everett and C. H. Sawyer, *Endocrinology*, **47**, 200, 1950.)

large follicles, providing that on the second and third days the dose is increased or supplemented by a second injection. Omission of any of these injections results in

ovulation during the ensuing night. Thus there is a clearly defined 24-hour rhythm in the LH-release mechanism. The results confirm a similar conclusion based on the

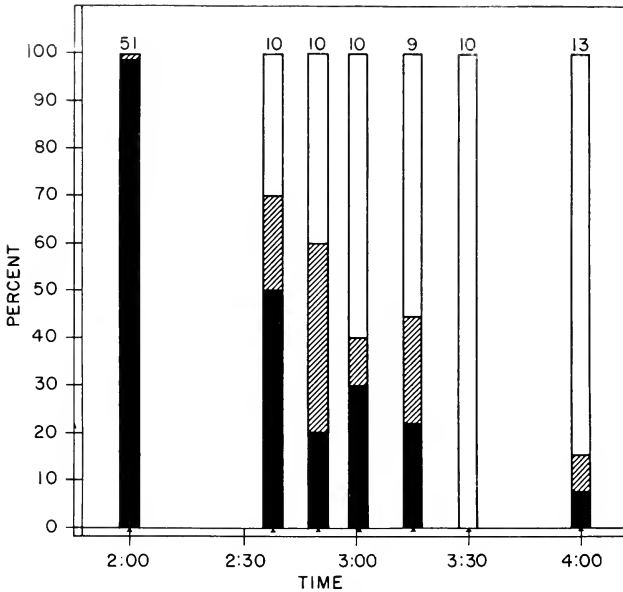

Fig. 8.11. The "critical period" in certain rats on the afternoon of proestrus (Vanderbilt strain, 4-day cycle, controlled lighting: 14 hours per day). Complete blockade of ovulation (solid bars) is regularly found if either atropine or Nembutal is administered at 2:00 p.m. Failure of blockade is usual when injections are made at 4:00 p.m. or later. Injection of atropine at different times during the critical period results in progressive decline of percentage blocked and often accomplishes only partial blockade (cross-hatching). (From J. W. Everett, *Ciba Foundation Colloquia Endocrinol.*, 4, 172, 1952.)

24-hour advancement of ovulation by progesterone. Approximately 24 hours before pituitary stimulation would occur spontaneously there is a period limited to a few hours during which progesterone can be effective (Everett and Sawyer, 1949). Although these time relationships were first recognized in a colony of inbred rats in North Carolina, they have since been confirmed in commercial rats (Sprague-Dawley) kept under controlled lighting for only a few weeks in southern California (Barraclough and Sawyer, 1955; Barraclough, 1955, 1956). In these studies morphine, reserpine, and chlorpromazine were consistently effective when injected during proestrus at 2 p.m., and ineffective at 4 p.m.

Not only is the critical period predictable under controlled lighting, but it may be readily changed by shifting the lighting schedule. For example, after an abrupt 3-

hour advance of the time switch controlling the lights, the animals slowly readjusted over a 2- to 3-week period (Everett, 1952b); when the switch was later returned to the original setting, they required again about 2 weeks to readjust. After a full 12-hour change of lighting schedule, full reversal of diurnal rhythms of activity and estrous behavior similarly requires about 2 weeks (Henningsen and Krarup, 1937).

The duration of the process of pituitary activation in rabbits and its time relationship to release of LH and the subsequent ovulation have been well defined (Table 8.1). In no other species is the available information so complete, but some advance has been made in the rat (also the hen; see chapter by van Tienhoven).

Duration of the activating stimulus in the rat has been estimated from the frequency of partial blockade of ovulation after atro-

pine injections in the midst of the critical period (Everett and Sawyer, 1953; Everett, 1956b). Unlike the trigger-like stimulus in rabbits, that in rats is prolonged to about a half-hour. In different individuals the stimulus begins at different times, (Fig. 8.11). Release of LH is probably coextensive with the stimulus. In parallel experiments carried out at various times during the critical period, groups of proestrous rats were hypophysectomized and other similar groups were injected with atropine. The two procedures gave essentially the same results, as measured on the following morning by the proportionate numbers of rats in which ovulation was found blocked or partially blocked (Everett, 1956b). The time interval from stimulation of the hypophysis to ovulation is 10 to 12 hours in rats (Everett, Sawyer and Markee, 1949), thus about the same as in rabbits.

#### D. PERSISTENT FOLLICLE

The state of persistent follicle may be considered as one in which for some reason there is a physiologic blockade of the hypothalamic ovulating stimulus. In the rabbit one may attribute failure of ovulation to absence of reflex stimulation, on the one hand, and a relatively high threshold of the hypothalamo-pituitary apparatus for estrogen and progesterone, on the other. In the rat certain conditions (*e.g.*, continuous illumination) elevate the threshold of the hypothalamo-pituitary system, with the result that persistent estrus and persistent follicle occur (Hemmingsen and Krarup, 1937; Browman, 1937; Everett, 1940a; Dempsey and Searles, 1943). Additional stimulation, furnished by either progesterone or coitus, is necessary to overcome this blockade.

An age factor is operative in the spontaneous onset of persistent follicle in old female rats. This condition is well recognized as an occasional occurrence (Evans and Long, 1921; Boling, Blandau, Rundlett and Young, 1941; Marvin and Meyer, 1941; Hartman, 1944). In the DA strain (Everett, 1939-1944) the age of onset was unusually early in segregated females under normal lighting conditions, *i.e.*, about 150 days of age which was more than 200 days earlier

than in a normal strain. In  $F_1$  hybrids the age of onset was intermediate. This factor, ill defined though it is, is also expressed in sensitivity to continuous illumination. Postpubertal rats of the normal strain in continuous light continued to experience regular cycles for as long as 40 days, whereas older animals (200 to 250 days) began to show persistent estrus within 10 days. Postpubertal DA rats, on the other hand, responded as promptly as 250-day-old normal rats. Hybrids again were intermediate. It was also found in older DA rats that had spontaneously developed persistent estrus under a lighting schedule of 14 hours per day, that reduction of the light ration to 9 hours usually restored cyclic function. It seems, then, that the age factor in question intensifies the effect of a given amount of daily illumination.

Interference with ovarian circulation in rats causes persistent follicle and failure of luteinization. This effect has been reported after ligation of the pedicle (Fels, 1952), ligation of the oviduct with resultant increase of pressure within the ovarian capsule (Haterius, 1936; Navori, Fugo and Davis, 1952), hysterectomy with increased pressure (Bradbury, Brown and Gray, 1950), and transplantation of the ovary to the tip of the tail (Hernandez, 1943; Bielschowsky and Hall, 1953). A possible explanation of this result is that the diminished blood flow releases insufficient estrogen to reach the threshold of the LH-release mechanism. An alternative explanation may be a change in the character of the secretory product of the ovary. "Cystic" changes of the ovaries are not uncommon after pelvic surgery in women.

The occurrence of persistent follicle in rats following partial nephrectomy (Diaz, 1940) has never been explained. It seemed to be correlated with the development of high blood pressure. Hence it may be allied with the experiments just described.

Pfeiffer (1936, 1937) reported that when testes are temporarily grafted into female rats during early infancy and removed before puberty the host animals exhibit constant estrus after reaching maturity. The same phenomenon has been observed after postnatal treatment with testosterone of

chorionic gonadotrophin (Selye, 1940; Bradbury, 1940, 1941), estrogen, progesterone, or desoxycorticosterone (Hale, 1944; Takasugi, 1954). The adult ovaries develop prominent follicles which never luteinize. Pfeiffer reported that his constant-estrous animals would not copulate. The conclusion was reached that the hypophyses of these rats had been masculinized by the early action of androgen. Subsequently (1941), he attempted unsuccessfully to invoke ovulation in similar animals by daily injection of small amounts of progesterone. Kempf (1950) later accomplished this with 2 injections, more widely spaced (interval, 1 week). Takasugi was unable to produce corpora lutea in postnatally estrogenized rats by chronic progesterone treatment after puberty, although vaginal cycles were observed. The further addition of androgen, interestingly enough, brought about luteinization. It would seem that a prime effect of the hormones during infancy is to produce a permanently high threshold in the hypothalamic ovulating mechanism without destroying it.

### VII. The Luteal Phase

The luteal phase presents more enigmas than the phases that precede it. What initiates it? What keeps it going? What brings it to an end? How is its duration determined?

Its beginning may arbitrarily be defined as the moment of ovulation, yet gestagen secretion may start during the follicular phase, and structural changes in the follicle wall during pre-ovulatory maturation may be considered as first steps in luteinization. From the time of follicle rupture onward the acquisition of full secretory activity by the corpora lutea roughly parallels their morphologic differentiation. It is even then a gradual process.

Luteinization as a structural change does not insure the attainment of secretory activity. The former is the ultimate effect of the preovulatory discharge of hypophyseal luteinizing hormone; some other (luteotrophic) factor must come into play to bring about and maintain gestagen secretion. We must, then, be concerned with the special character of luteotrophins, with mechanisms that favor their secretion by the hypophysis, with mechanisms that shorten or

lengthen the life of the corpus luteum and, therefore, with the mechanisms that normally bring the corpus luteum phase to an end. In the final analysis this last has an importance equal to the ovulation mechanism in the timing of recurrent cycles.

#### 1. Luteotrophic Substances

The term luteotrophin was proposed by Astwood (1941) to refer to a substance that maintains function of corpora lutea, in distinction to substances that cause them to form. It is now conceded that the substance described in that paper was probably the lactogenic hormone. Evans, Simpson, Lyons and Turpeinen (1941) demonstrated that purified lactogen is luteotrophic in hypophysectomized rats. This has been confirmed by several later investigations (Tobin, 1942; Nelson and Pichette, 1943; Everett, 1944b; Desclin, 1948; Gaarenstroom and de Jongh, 1946). Although lactogen seems to be the hypophyseal luteotrophin in rats, such is not necessarily true for all species (Bradbury, Brown and Gray, 1950). Nevertheless, the expression luteotrophin in the generic sense continues to be desirable.

In the rabbit, lactogen is said to have little, if any, luteotrophic effect (Klein and Mayer, 1943; Mayer, 1951). Yet rabbits have never been tested with rabbit lactogen. Several workers have failed to demonstrate a luteotrophic function of lactogen preparations in monkeys (Hisaw, 1944; Bryans, 1951) and women (Holmstrom and Jones, 1949; Bradbury, Brown and Gray, 1950). Positive evidence of such activity in primates furnished by Fried and Rakoff (1952) and more recently by Lyon (1956) has not gained wide acceptance. The former authors reported that amounts of chorionic gonadotrophin which were themselves inadequate, when supplemented by lactogen (Luteotrophin, Squibb) prolonged the functional life of the corpus luteum in nonpregnant women. Lyon reported such prolongation using lactogen alone. The Squibb lactogen was also used by Moore and Nalbandov (1955) in prolonging the luteal phase of the cycle in the ewe. As in the human experiments, however, one would like to know whether lactogen is capable of initial stimulation of secretory activity of corpora lutea and of maintaining their function in the ab-

sence of the hypophysis. There is no evidence for or against the lactogenic hormone in this capacity, except in rats.

Estrogens have direct luteotrophic action in the rabbit (Robson, 1937, 1938, 1947). The effect does not depend on the hypophysis and has been produced by implantation of estrogen crystals within corpora lutea (Hammond, Jr., and Robson, 1951; Hammond, Jr., 1952). Westman (1934) had earlier shown that operative reduction of ovarian stroma in pseudopregnant rabbits results in corpus luteum regression and that this can be prevented by administration of estrogen. Corpora lutea induced by gonadotrophin injection or by mating, as the case may be, require the presence of the hypophysis for their continued function (Smith and White, 1931; Westman and Jacobsen, 1936). Theoretically, then, in rabbits the hypophysis liberates FSH and LH which act on the interstitial tissue to cause estrogen secretion. This in turn stimulates the corpora lutea to secrete progesterone.

The effect of estrogen on the corpora lutea of rats is largely indirect and requires the presence of the hypophysis. Massive dosage with estrogen beginning soon after ovulation results in the enlargement of the corpora lutea and the production of sufficient amounts of progesterone to mucify the vaginal mucosa (Selye, Collip and Thomson, 1935; Wolfe, 1935; Deselin, 1935; Merckel and Nelson, 1940). In fact, a single injection of 50  $\mu$ g. estradiol benzoate on the day after ovulation is sufficient to cause pseudopregnancy. These effects are now judged to be the result of induced liberation of hypophyseal luteotrophin. Similar effects have been reported after administration of androgens (McKeown and Zuckerman, 1937; Wolfe and Hamilton, 1937; Freed, Greenhill and Soskin, 1938; Laqueur and Fluhmann, 1942).

Deselin (1949b) stated that in hypophysectomized rats the administration of estrogen augments the luteotrophic action of lactogen, producing functional corpora lutea in the presence of subthreshold doses of the latter hormone. A physiologic synergism of the two substances has thus been indicated. Mayer (1951) suggested that this may explain the stimulation of corpora lutea of lactation which follows estrogen treat-

ment in this species. Greep and Chester Jones (1950) postulated that estrogen favors corpus luteum function in the rat by causing the luteal cells to produce cholesterol as a precursor of progesterone. Their actual data, however, indicate that the increase of visible cholesterol after estrogen treatment was confined to the interstitial tissue.

Factors responsible for cholesterol storage and mobilization in corpora lutea of the rat were analyzed by Everett (1947). In hypophysectomized rats in which corpora lutea were maintained by lactogen the injection of pituitary LH induced the storage of cholesterol, but this effect did not occur in hypophysectomized rats in the absence of lactogen. It could be induced during pregnancy or pseudopregnancy by estrogen if the hypophysis remained in place. Addition of an excess of lactogen prevented cholesterol storage. Lactogen thus tends to deplete cholesterol content of rat luteal tissue as ACTH tends to deplete adrenocortical cholesterol.

## 2. "Nonfunctional" Corpora Lutea

In the short cycles of the rat, mouse, hamster, and so on, the corpora lutea are commonly said to be nonfunctional. The meaning of this statement, of course, is that they are incapable of supporting a decidual reaction (Long and Evans, 1922), or of preventing ovulation. They need not be totally inactive, however, to fail to cause these manifestations. Whereas daily injection of 1.5 mg. or more of progesterone into intact female rats will simulate pseudopregnancy and indefinitely delay ovulation (Selye, Browne and Collip, 1936; Phillips, 1937), smaller amounts of 1.0 mg. or less are compatible with the short cycle (Lahr and Riddle, 1936; Phillips, 1937; Everett, 1940a, b; and unpublished). In the absence of estrogen in castrated females, daily injection of as little as 0.25 mg. progesterone will support deciduomata (Velardo and Hisaw, 1951). Very small amounts of estrogen augment this action of progesterone (Rothchild, Meyer and Spielman, 1940) but somewhat larger amounts are inhibitory unless the progesterone dose is proportionately increased (Velardo and Hisaw, 1951). In the intact animal the progestational effects of

less than 1.0 mg. progesterone would be inhibited by the periodic rise in estrogen secretion.

Evidence that some rats, but not all, actually experience low-grade corpus luteum activity during the short cycle was furnished by Everett (1945). In the comparison of ovaries from females of two strains of rats, it was noted in the supposedly normal Vanderbilt strain that on the two days immediately following ovulation the corpora lutea of the next youngest generation contained a great quantity of cholesterol, giving a strong Schultz reaction. By contrast, comparable corpora lutea of the DA strain were usually free of visible lipid in Sudan preparations or the Schultz test. Administration of small amounts of lactogen (luteotrophin) during the cycle preceding the current one, amounts inadequate to cause pseudopregnancy, resulted in the rich deposition of cholesterol in these otherwise lipid-free corpora lutea. The conclusion was reached that the corpora lutea of the Vanderbilt rat must be slightly active during the short cycle and those of the DA rat less so, if at all. This would easily explain the relative indifference of the Vanderbilt rat to continuous light and the ease with which persistent estrus could be induced in the DA rat by such treatment (Everett, 1942a, b). In fact, the low dosages of lactogen mentioned substituted for progesterone treatment in maintaining regular cycles in persistent-estrous rats of the DA strain (Everett, 1944b). Significantly, the treatment was effective in only those animals in which a set of corpora lutea had been induced by other means at the beginning of the experiment.

To be correlated with the above indications of low-grade function during the short cycle, is the finding that corpora lutea of the Vanderbilt rat retain full responsiveness to luteotrophin throughout most of the di-estrous interval (Nikitovitch-Winer and Everett, 1958a). Responsiveness diminishes near the onset of proestrus. Once the rat has entered proestrus these older corpora lutea are not capable of sustained function. The loss is not a function of time *per se*, but of stage of the cycle.

#### A. PSEUDOPREGNANCY

The terms corpus luteum of ovulation and corpus luteum of pseudopregnancy are com-

monly used to differentiate the luteal bodies occurring during the normal cycles from those found during some unusually long period of luteal activity. However, the terms deny the fundamental similarity of the luteal phase in the cycles of such animals as the guinea pig and the luteal phase induced by sterile mating or its equivalent in animals like the rat. In the unmated bitch the spontaneous luteal phase of the cycle is commonly called pseudopregnancy, yet it is equally common to say that the guinea pig does not experience pseudopregnancy. The truth is that the luteal phase of the canine cycle is simply longer than the luteal phase in the guinea pig and may be marked by a period of lactation near its close. In the present discussion, the expression pseudopregnancy will be equivalent to saying the luteal phase of the infertile cycle. Under experimental conditions it will refer to any period of sustained luteal function similar to that of the normal progestational state. Wherever appropriate, the distinction will be made between a pseudopregnancy that is spontaneous and one that is induced.

In most of the familiar animals that ovulate spontaneously corpus luteum function also begins spontaneously and continues for at least several days after ovulation. With respect to the rabbit, cat, and ferret, it is often said that pseudopregnancy is invoked by sterile copulation, whereas strictly speaking it is only ovulation and corpus luteum formation which are invoked. The pseudopregnancy then follows automatically. This interpretation seems appropriate, inasmuch as in all three species the formation of corpora lutea by brief treatment with hypophyseal or chorionic gonadotrophin is followed by long periods of progesterone secretion which can hardly be the direct effect of the injected substances (Hill and Parkes, 1930a, b; Foster and Hisaw, 1935; van Dyke and Li, 1938). Quite different is the pseudopregnancy of the rat, mouse, and hamster, in which progestational activity is invoked by stimulation of the cervix uteri. Everett (1952a) described the experimental dissociation in rats of the ovulation and luteotrophic mechanisms, respectively. When ovulation is blocked (by pentobarbital) in the cycle during which controlled mating occurs, pseudopregnancy begins



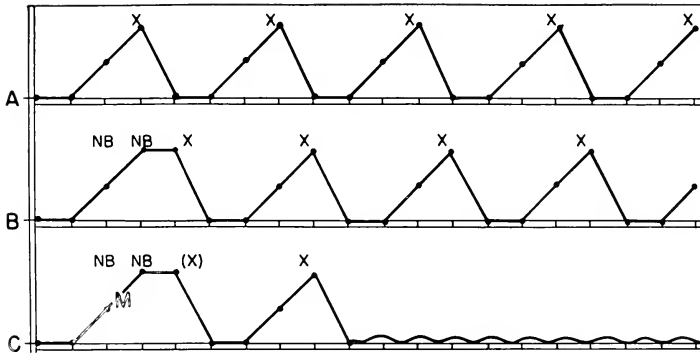

FIG. 8.12. Experimental dissociation in rats of the ovulation mechanism and that causing pseudopregnancy. *A*. Control cycles for comparison with *B* and *C*. Points on base line represent diestrus, on ascending lines proestrus, on highest level full vaginal estrus. *X*, ovulation. *B*. Blockade with Nombutal (*NB*) on day of proestrus and following day (see Fig. 8.11*E*). Ovulation during third night. *C*. Same basic procedure as *B*, but with copulation during first night (*M*). Ovulation usually failing in this cycle (contrast with *B*). Corpora lutea formed after spontaneous ovulation in second cycle regularly become functional without further stimulation: the wavy line represents pseudopregnancy. The early copulation has introduced some change in the animal such that this pseudopregnancy "spontaneously" follows ovulation as in the standard mammalian cycle. (From J. W. Everett, *Ciba Foundation Colloquia Endocrinol.*, 4, 172, 1952.)

"spontaneously" after the next cyclic estrus (Fig. 8.12). Dissociation of the two mechanisms is expressed in another way by certain Mustelidae, *e.g.*, the mink and marten. Ovulation in these forms is invoked by mating, whereas corpus luteum activation awaits appropriate environmental conditions, *i.e.*, temperature and length of daily illumination (Pearson and Enders, 1944; Hansson, 1947). In the mink, during the period of relative luteal inactivity that follows mating early in the season, recurrent estrus continues. If remating takes place at an interval of 6 days or more, new ovulations are induced (Hansson, 1947). Matings late in the season are immediately followed by luteal activity. The pseudopregnant cycles of a representative series of mammals are much alike when conditions appropriate to the respective species are applied (Fig. 8.1).

### 1. Duration of Pseudopregnancy

The length of time that corpora lutea remain functional in the pseudopregnant cycle is thought to be relatively uniform in the great majority of mammals, usually about 10 to 15 days. Rarely it is shorter,

*e.g.*, the hamster, 7 days, although usually 9 to 10 days (Asdell, 1946). At the other extreme, the corpora lutea remain functional for periods corresponding to the duration of pregnancy, as in the ferret, 5 to 6 weeks. In fact, corpus luteum function lasting over a month is usual in the other two carnivores for which information is at hand: cat, 30 to 44 days (Foster and Hisaw, 1935); and dog, 30 days or more (Evans and Cole, 1931).

These figures are only approximations, however, as the criteria on which they are based differ. In the rat, in which pseudopregnancy is said to last 12 to 14 days, its termination is taken to be the onset of the next estrus, whereas the corpora lutea must have undergone a decline of activity 2 or 3 days earlier (Everett, 1948). The decline is probably not abrupt, inasmuch as the vaginal smear during the next estrus is very strongly mucified and, as mentioned earlier (p. 519), enough progesterone seems to be secreted by the waning corpora lutea to facilitate ovulation. Morphologic criteria are often employed as indicators of corpus luteum regression: characteristically, fatty vacuolation of luteal cells, decrease in size of the individual cells or of the entire corpus

luteum, and changes in the sinusoidal pattern suggesting reduced circulation. Such changes are first observed in the guinea pig corpora lutea on about the 13th day of the cycle. One has the choice of taking this date as the end of the pseudopregnant phase or, alternatively, the date on which the first indications of estrus are noted. Either choice is arbitrary, but the former seems preferable as it suggests that progesterone secretion is diminishing and probably is no longer sufficient to maintain progestational changes in the uterus. In fact, regression of the endometrium sets in about a day earlier than frank degenerative changes in the corpora lutea. In the cat, according to van Dyke and Li (1938) the corpora lutea 20 days after ovulation no longer secrete enough progesterone to cause motor effects of epinephrine in the myometrium, the so-called "epinephrine-reversal" effect, yet by histologic criteria corpus luteum regression is not apparent until 28 days or later (Liche, 1939; Foster and Hisaw, 1935). In the bitch the uterus begins regression 20 to 30 days after heat, but the corpora lutea are said to remain in good condition for a longer time (see Asdell, 1946, for references). Regression is so gradual that anestrus is not reached until about 85 days. In the primates the beginning of menstruation offers a means of delimiting the luteal phase, inasmuch as menstruation in the ovulatory cycle reflects a marked reduction in corpus luteum function. Nevertheless, this reduction probably occurs a few days before bleeding begins. The peak of pregnandiol excretion in women (Vemming and Browne, 1937) and of plasma progesterone concentration in women and monkeys (Forbes, 1950; Bryans, 1951) is passed about midway between ovulation and menstruation.

## 2. Neural Factors in Pseudopregnancy

The importance of the nervous system in control of pseudopregnancy is well recognized in only the few species represented by the rat. A neural effect in the mink and similar Mustelidae is implied by the relation of luteal function to daily illumination, as mentioned earlier. Beyond that fact, however, no information is available. Attention will therefore be directed largely to the rat.

Not only sterile mating, but several other

procedures involving neural stimulation will cause rats to become pseudopregnant. Stimulation of the cervix by mechanical means (Long and Evans, 1922) or electric shock (Shelesnyak, 1931) have become standard methods. In fact, Greep and Hisaw (1938) obtained pseudopregnancies after electrical stimulation during early diestrus, several days before ovulation. Pseudopregnancy is also invoked by continuous stimulation of the nipples for several days (Selye and McKeown, 1934). According to Harris (1936) electric shock through the head is effective. His negative results with "spinal shock" are difficult to explain. From the description of position of the electrode it seems doubtful that the current passed through the cord itself, yet the sacral plexus must have been stimulated.

Abdominal sympathectomy or superior cervical ganglionectomy are said to diminish the numbers of animals responding to electrical or mechanical stimulation of the cervix (Vogt, 1931; Haterius, 1933; Friedgood and Bevin, 1941). On the other hand, there is no diminution of response to sterile copulation, which shows that the sympathetic chains are not essential. Ball (1934) emphasized the quantitative aspects of the problem, noting that partial resection of the uterus or excision of the cervix diminished the response to sterile copulation, but only when "single-plug" matings were allowed. Multiple plugs gave pseudopregnancy in 100 per cent of the animals. It may be assumed that Vogt's (1933) negative results after hysterectomy resulted from single-plug copulations. Kollar (1953) re-opened the question and found that pelvic nerve resection usually prevented the response to mating. It is not clear, however, whether multiple copulations were the rule, although it seems that the routine procedure was to leave the male with the female overnight. His contention was that cervicectomy fails to abolish the response completely because the vagina remains sensitive.

Anesthesia with ether, nitrous oxide, or ethylene (Meyer, Leonard and Hisaw, 1929) diminished the frequency of response to mechanical stimulation of the cervix. The statement was made, although without evidence, that spinal anesthesia prevents pseudopregnancy. According to Vogt (1933),

local anesthesia of the vagina and cervix by cocaine or procaine prevented the response to sterile copulation in 23 of 35 rats.

Removal of neocortex (Davis, 1939) did not interfere with the pseudopregnancy response to electrical stimulation of the cervix, although there was slight impairment of the response to mechanical stimulation or sterile mating (single-plug?).

These results taken together have been construed to mean that induction of pseudopregnancy in rats involves a reflex similar to the ovulation reflex in rabbits. Certain considerations, however, raise the possibility that it may not be a "trigger" stimulus to the hypophysis as long believed (Everett, 1952a). In the first place, it seems doubtful that a trigger stimulus would result in continuation of a new pattern of secretion (luteotrophin) for as long as 10 to 12 days. Furthermore, as noted above, cervical stimulation during the diestrus preceding ovulation may induce pseudopregnancy (Greep and Hisaw, 1938). Similarly, copulation during a cycle in which ovulation is blocked by pentobarbital results in a pseudopregnancy that begins after the next estrus (Fig. 8.12).

We turn now to experiments concerned directly with the hypothalamo-pituitary system and pseudopregnancy. Westman and Jacobsohn (1938c) cut the pituitary stalks of estrous female rats. Barriers of metal foil were inserted to prevent regeneration of nerve fibers assumed to innervate the adeno-hypophysis. Regeneration of blood vessels must have been equally impossible. Controls were simply hypophysectomized. Two to 5 hours after the operations electrical stimulation of the cervix was administered to all animals. Pseudopregnancies were demonstrated by decidualomas in traumatized uteri of all the stalk-sectioned animals but not in the completely hypophysectomized rats. Desclin (1950) reported the maintenance of pseudopregnancy in estrogen-treated rats in which the only remaining hypophyseal tissue was in the form of grafts in the kidney. Whereas in hypophysectomized controls the estrogen treatment (stilbestrol pellets) produced cornification of the vagina and no enlargement of corpora lutea, the grafted-estrogenized rats developed mucified vaginas and enlarged corpora lutea as

in intact rats similarly treated with estrogen. Desclin concluded that the grafted hypophysis is able to respond to estrogen by liberating luteotrophin.

It is now apparent, however, that neither cervical stimulation nor estrogen treatment is needed to invoke pseudopregnancy when the gland is isolated from the hypothalamus (Everett, 1954, 1956a; Nikitovitch-Winer and Everett, 1958a; Sanders and Rennels, 1957; Desclin, 1956a, b). When autografts of anterior hypophysis were made to the renal capsule or near the common carotid artery on the day after ovulation in adult cyclic rats, corpus luteum function was invoked and maintained without any stimulus other than the operative procedures themselves. In short-term experiments in which the uteri were traumatized 4 days after the transplantation large decidualomas were regularly found at 8 days in the proven absence of residual hypophyseal tissue at the original site (Everett, 1954). Hypophysectomized controls were negative. In long-term experiments, continuing luteal function was demonstrated for as long as 3 months. Here the test for luteal function was vaginal mucification in the presence of massive amounts of estrogen administered during the final week of the experiment (Everett, 1956a). Controls in which the grafts or the ovaries were removed at the beginning of such estrogen treatment responded with full vaginal cornification. Follicular apparatus and interstitial tissue of the ovaries atrophied promptly after the grafting operations, whereas corpora lutea forming at that time were maintained for the long periods without histologic sign of deterioration. In later work, the decidual reaction was used as the test for luteal function, positive reactions being elicited as late as 2 months after the transplantation. It was discovered that function of the graft is not influenced by stage of the cycle at which transplantation is carried out and that grafts in the anterior chamber of the eye secrete luteotrophin like those on the kidney (Nikitovitch-Winer and Everett, 1958a). Transsection of the pituitary stalk is sufficient in itself to provoke pseudopregnancy. If an effective barrier to vascular regeneration is inserted, the pseudopregnancy will be permanent, but otherwise it will last only

usual length of time (Nikitovitch-Winer, 1957). In fact, there is reason to suspect that even a transient impairment of circulation in the median eminence-hypophysial linkage can be a sufficient impetus to pseudopregnancy. The experiments of Taubenhau and Soskin (1941) in which application of an acetylcholine-prostigmine mixture to the exposed hypophysis was followed by pseudopregnancy, may well be explained in some such way.

It thus seems that in the rat the deprivation of, or interference with, the normal connection of the pars distalis with the median eminence facilitates secretion of luteotrophin and at the same time eliminates luteolytic mechanisms. It is significant that transplants of pars distalis into the pituitary capsule or to the immediate vicinity of the median eminence resume cyclic function (see page 512). The hypothalamus may have an inhibitory effect on luteotrophic activity of the pars distalis during the short cycle in this species. Greep and Chester Jones (1950) made the pertinent suggestion in attempting to explain the induction of pseudopregnancy by estrogen treatment, that the fundamental action of estrogen here is the suppression of FSH and LH, after which luteotrophic secretion may "proceed apace."

There is necessarily some uncertainty concerning the amount of luteotrophin secreted by the pars distalis when dissociated from the brain. Three sets of facts indicate that the output is larger than that in the cycling animal. (1) Sufficient gestagen is secreted by the engrafted animal to maintain a pregnancy (Everett, 1956c; Meyer, Prasad and Cochrane, 1958) when the pituitary is transplanted on the day after mating. (2) After stalk-transsection, in which there is less initial destruction of glandular parenchyma than in transplantation experiments, the corpora lutea enlarge to a diameter like that usually found in late pregnancy rather than remaining like those of pseudopregnancy (Nikitovitch-Winer, 1957). (3) A single homotransplant of pars distalis placed subcutaneously in an otherwise normal female mouse will maintain a sequence of pseudopregnancies that override the short cycles expected of the animal's own hypophysis (Mühlbock and Boot, 1959). This is also true of rats (Nikitovitch-

Winer, unpublished). To avoid the conclusion that in such preparations the grafted gland is secreting luteotrophin at an increased rate, one must assume that the output of this hormone from the intact gland is only slightly below threshold and that the graft adds just enough to make the total output effective. To explain the maintenance of pregnancy one might assume that the luteotrophin output and the resulting gestagen secretion are no greater than during the normal short cycle and that the formation of deciduomas takes place because of the deficiency of estrogen. The results of stalk-section, however, cannot easily be explained away. The weight of evidence, then, is in favor of increased luteotrophin secretion by hypophyses isolated from the brain by severance of the stalk or transplantation.

Under certain experimental conditions it has seemed that to establish pseudopregnancy all that is necessary is to block out the forthcoming estrus and ovulation. Thus, in cycling rats, when the hypophysis is transplanted to the kidney as late as 60 hours after ovulation, the current diestrus transforms into a permanent pseudopregnancy supported by the existing set of corpora lutea (Nikitovitch-Winer and Everett, 1958a). Similarly, injections of chlorpromazine (Barraclough, 1957) or Pathilon (Gitsch and Everett, 1958) begun during diestrus, may transform it into a pseudopregnancy by blocking out the expected estrus.

The Mühlbock-Boot experiment mentioned above furnishes an instructive model of the standard mammalian cycle, in which both ovulation and pseudopregnancy are spontaneous events. Given the extra pituitary tissue producing luteotrophin at a presumably constant rate, with the output of the normal gland fluctuating quantitatively and qualitatively, the mouse or rat undergoes one pseudopregnancy after another. Possibly, in animals that normally have a spontaneous luteal phase, there is a considerable portion of the pars distalis which functions somewhat independently of the hypothalamus, with a continuous output of luteotrophin as from the grafted gland in the Mühlbock-Boot preparation. The portion more directly under control of the median eminence (zona tuberalis?) would

then act like the intact hypophysis of the Mühlbock-Boot mouse. Such a view, unfortunately, continues to set apart species in which the luteal phase is not spontaneous, by suggesting that only in them are special neural mechanisms involved.

#### B. LUTEOLYTIC MECHANISMS

By luteolysis we shall refer to corpus luteum regression in any of its manifestations. Supposedly the initial change is functional, after which overt cytologic and histologic changes appear, leading eventually to the total loss of glandular tissue. Very likely the initial stages are occult and only gradually reach recognizable proportions. Mention was made earlier of the fact that in women and monkeys the peak of gestagen secretion is about midway between ovulation and menstruation. In rats indirect evidence from progesterone injection experiments leads to the deduction that toward the close of a pseudopregnancy gestagen secretion must drop below the estrus-suppressing level several days before estrous changes appear in the vaginal smear (see Fig. 8.8). A more abrupt drop is reported for the ewe between the 16th and 17th (last) days of the cycle (Edgar and Ronaldson, 1958).

Long-term experiments with pituitary autotransplants indicate that at least in the rat the life span of the corpus luteum is not limited by intrinsic factors. Some agent(s) of extra-ovarian origin must, therefore, be responsible for at least the initial luteolytic changes. Various bits of information suggest that the agent is associated with, if not identical with, FSH and or LH. Grep (1938) noted that after hypophysectomy in rats the daily injection of LH over a period of 10 days caused the corpora lutea to regress more rapidly than otherwise. Grep, van Dyke and Chow (1942) later were unable to repeat this with a more highly purified LH ("metakentrin"), a fact suggesting that the earlier material was effective because of impurity. During the short cycle of the rat, luteolysis is interrupted by transplantation of the pars distalis (Everett, 1954; Nikitovitch-Winer and Everett, 1958a). Whatever regressive changes are in progress at that moment are evidently suspended forthwith. They are first appar-

ent during the third day of diestrus and become increasingly pronounced during proestrus and estrus. In this connection, it should be recalled that during late diestrus and proestrus patches of cells undergoing fatty necrosis are first recognizable histologically (Boling, 1942; Everett, 1945).

Why is it that, in the face of a continuing supply of luteotrophin in the Mühlbock-Boot preparation, or in intact animals injected daily with lactogen (Lahr and Riddle, 1936; Aschheim, 1954), luteolysis sets in during the 2nd week? The question obviously cannot be answered from present knowledge. Nevertheless, it is clear that the pseudopregnancy that transpires when a significant portion of hypophyseal tissue remains in normal relation to the hypothalamus is far from the steady state of that which becomes established by total removal of the pars distalis to an extracranial site. It is also apparent that the onset of luteolysis may be postponed by such means as hysterectomy or production of artificial deciduomas (see p. 538). Furthermore, during lactation-pseudopregnancies in rats, Canivene and Mayer (1953) prolonged luteal function to 34 days by substituting successive new litters of suckling young. This technique should prove especially valuable in experimental analysis of both luteotrophic and luteolytic mechanisms.

Benson and Folley (1956) suggested that lactogen secretion is activated by oxytocin, inasmuch as its injection prevented the normal involution of the mammary glands after withdrawal of the litters from lactating rats. This observation has been confirmed by McCann, Mack and Gade (1958), who also noted the interruption of lactation by lesions of the supraoptico-hypophyseal tract. Selye and McKeown (1934) long ago found that pseudopregnancy could be induced in cycling rats by the introduction of a suckling litter. Although all this is consistent with the above-mentioned observation by Canivene and Mayer, other workers have observed luteolytic effects of gonadotrophin-free oxytocin administered to cycling dairy heifers (Armstrong and Hansel, 1958). Furthermore, Grosvenor and Turner (1958), after first noting that the administration of Dibenamine, atropine, or pentobarbital to rats prevented the expected drop in assay-

able pituitary lactogen at nursing, found no decrease when pentobarbitalized mothers were injected with physiologic doses of oxygen intravenously. When the dosage was increased 30 to 60 times there was apparently some moderate discharge, but the authors regard it as insignificant.

#### C. EFFECT OF THE UTERUS ON LUTEAL FUNCTION

This subject has been reviewed by Bradbury, Brown and Gray (1950). In three species (Fig. 8.13) hysterectomy results in significant prolongation of the functional life-span of corpora lutea (guinea pig, Loeb, 1927; rabbit, Asdell and Hammond, 1933; rat, Bradbury, 1937). In each case the period of luteal function approximates that of normal pregnancy. The fact that corpora lutea in the pseudopregnant ferret normally function as long as in the pregnant animal may be a clue to the noneffect of hysterectomy in that species (Deanesly and Parkes,

1933). Although Burford and Diddle (1936) reported that in monkeys total hysterectomy was followed by vaginal cycles of normal length, examination of their protocols shows that during the several postoperative months just 1 corpus luteum was produced among all 5 animals. The experiment thus seems inconclusive. Impairment of pelvic circulation seems to be a common factor complicating the results of hysterectomy in women and may have been one cause of the failure of luteinization in these monkeys.

An interpretation given by Loeb (1927) and Bradbury, Brown and Gray (1950) for the prolongation of luteal function by hysterectomy is that in species in which the effect is demonstrable the uterus secretes a specific substance which abbreviates the life of the corpus luteum. Hechter, Fraenkel, Lev and Soskin (1940) found in rats that grafts of estrous uteri shortened the pseudopregnancies of hysterectomized animals to normal length. Implantation of similar tis-

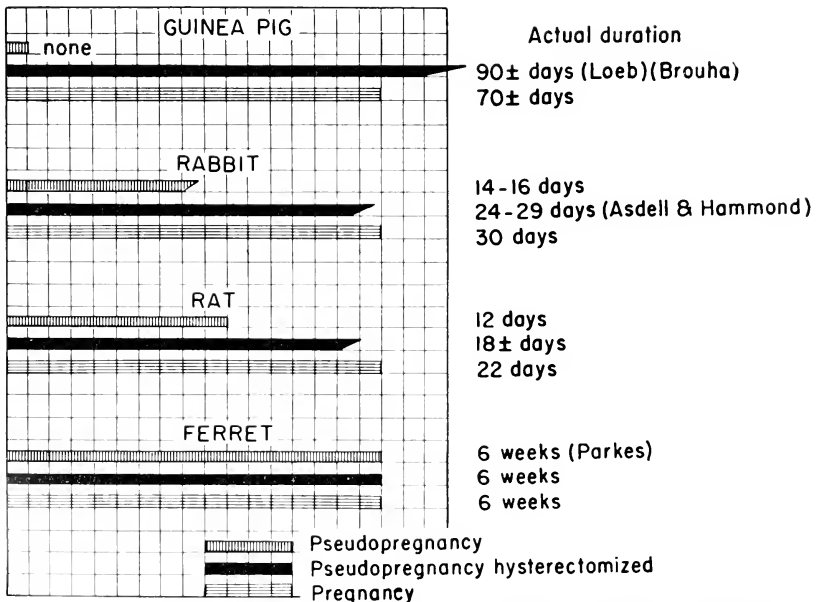

FIG. 8.13. Relative durations of pseudopregnancy in normal and hysterectomized animals of four species in relation to the duration of gestation characteristic of each. Gestation plotted as a common unit of time. (After J. T. Bradbury, W. E. Brown and L. A. Gray, *Recent Progr. Hormone Res.*, 5, 151-194, 1950.)

sue which had been killed by freezing had no such effect, nor did successful grafts of uteri from diestrous donors. Bradbury, Brown and Gray (1950) found that partially hysterectomized rats in which the remaining uterine tissue was continuous with the cervix, hence properly drained, experienced pseudopregnancies of normal length. However, when the continuity was interrupted the uterine remnants became greatly distended, the endometrium was destroyed, and the animals had prolonged pseudopregnancies. Possibly the endometrium is the source of the hypothetical "luteolytic" substance.<sup>6</sup>

Under other circumstances the endometrium of rats has a luteotrophic rather than luteolytic effect, for when deciduomas are induced by trauma the pseudopregnancies of otherwise normal animals are lengthened to 22 days or more (Ershoff and Duell, 1943; Velardo, Dawson, Olsen and Hisaw, 1953). This is not true in mice, however, and Kamell and Atkinson (1948) suggest that the reason may lie in the shorter life-span of the decidual tissue in that species. Loeb (1927) reported that deciduomas in cyclic guinea pigs prolonged the luteal phase, *i.e.*, delayed the next ovulation from 3 to 7 days, which is far less than the prolongation after hysterectomy.

As an alternative to the concept of control of the corpus luteum by humoral agents

<sup>6</sup>The denial by Velardo, Olsen, Hisaw and Dawson (1953) that hysterectomy in rats prolongs pseudopregnancy is based on operations performed later in the luteal phase than those of Bradbury, Brown and Gray and of Hechter, Fraenkel, Lev and Soskin. Whereas the latter workers had operated in the range from the 4th to the 7th days of pseudopregnancy and many of Bradbury's cases lacked uteri when they entered pseudopregnancy, Velardo and associates excised the uteri on the 9th day. It seems possible that this difference in time may be crucial, for by the 9th day of a 12-day pseudopregnancy the corpora lutea must be on the verge of regression, if that process has not already been initiated. After maintaining pseudopregnancy in estrogenized, hypophysectomized rats by means of lactogen, its withdrawal is followed about 3 days later by estrous smears (Nelson and Pichette, 1943; Nelson, 1946). A slightly longer delay occurs in non-estrogenized, intact rats at the end of a lactogen-induced pseudopregnancy (Everett, unpublished) or after withdrawal of progesterone treatment (Fig. 8C).

formed in the uterus, Loeb considered the possibility that neural mechanisms are involved. The idea was not acceptable, he felt, because in partial hysterectomies the result was not determined by the locus of the part removed. The finding by Hechter, Fraenkel, Lev and Soskin (1940) that grafts of uterine tissue in hysterectomized rats return the duration of pseudopregnancy to normal, is significant evidence pointing in the same direction.

A third hypothesis was advanced by Hecker (1942) who found in rabbits that the extent of prolongation of luteal function by subtotal hysterectomy is roughly proportional to the amount of uterine tissue removed. The suggestion was offered that removal of the uterus has an estrogen-sparing effect. The greater amount of estrogen thus available to the corpora lutea prolongs their life, according to this view.

Later investigations by Moore and Nalbandov (1953) revive the possibility that the uterus influences the ovary by way of the nervous system. In sheep the implantation of a plastic bead *in utero* during the early luteal phase shortened the cycle by several days. Successive cycles tended to be unusually short. When the uterine segments containing the beads were denervated, however, the cycles were essentially normal. Other work from the same laboratory (Huston and Nalbandov, 1953) which indirectly may bear on this problem, indicates that the presence of a mechanical irritant (a thread) in the oviduct of the domestic fowl tends to block ovulation. The blockade may extend for as long as 20 days if the thread is placed in the isthmus (van Tienhoven, 1953). The ovaries remain functional, producing large follicles which may be ovulated at will by injection of LH. The authors feel that this phenomenon, like the effect of the bead in the sheep uterus, involves a neural mechanism, but crucial information is lacking. It may be significant that stimulation of the ovaries was found in some hens, in place of blockade.

We may hope that as more information becomes available the assortment of facts given in these paragraphs will fit into a rational system. Not until this is realized can we hope to understand the regulation of the luteal phase.

### VIII. Concluding Comments

From what has been written here it is readily apparent that present knowledge of the mechanisms controlling the reproductive cycle is extremely spotty. The number of assumptions necessary to knit the various items of factual information into an orderly pattern is disturbing. In spite of a voluminous literature which has grown during the last 60 years, we are really only a few steps ahead of our predecessors at the turn of the century in terms of fundamental understanding. A brief recounting of some of these steps may be desirable.

The first three decades saw the gradual development of proof that the ovary is a gland of internal secretion as well as the producer of eggs, governing the uterus and other accessory organs by secretion of hormones into the blood stream. For a while it seemed that the events of the reproductive cycle could be neatly explained, with the ovary in the capacity of controlling agent. Yet there were indications that the ovary itself is not independent. As early as 1909-1910 (Aschner; Crowe, Cushing and Homans) it was noted that destruction of the hypophysis is accompanied by atrophy of the gonads and reproductive tract. In 1927 the separate investigations of Smith and Engle and of Zondek and Aschheim demonstrated conclusively that function of the ovary depends vitally on the anterior hypophysis. Promptly it was learned that the hypophyseal secretion of gonadotrophic hormone is in turn modified by estrogens. In the early 1930's the "push-pull" hypothesis of pituitary-ovarian interaction was separately stated by Brouha and Simonnet and by Moore (see Moore and Price, 1932). Modified in detail as new facts appeared, this hypothesis is held to the present day in some quarters as a simple explanation of how the cycle comes about in polyestrous, continuous breeders in which ovulation takes place spontaneously. Much of the investigation of pituitary-ovarian physiology during the 1930's was performed within the framework of this hypothesis.

For seasonal breeders and reflex ovulators, however, the assumption was necessary that special controlling mechanisms are superimposed. It became recognized also that in

some vaguely defined manner even the human cycle is subject to intervention of the nervous system. The possible importance of the hypothalamus was debated at some length in the twenties. In 1932 the existence of a sex center there was proposed by Hohlweg and Junkmann. In an attempt to explain the coital excitation of the rabbit hypophysis which causes the liberation of gonadotrophin, Hinsey and Markee (1933) suggested diffusion of a chemical substance from the posterior lobe to the anterior lobe. Hinsey (1937) later elaborated on this possibility and mentioned the hypophyseal portal vessels as a plausible route by which the substance might travel. We have seen the later history of these ideas.

The "Sexualeentrum" of Hohlweg and Junkmann was proposed as a mediator of the effects of estrogen on the anterior hypophysis of rats. Westman and Jacobsohn (1936-1940), on the other hand, believed that through its stalk connection with the hypophysis the rat hypothalamus governs gonadotrophin synthesis, not release. The latter they regarded as a direct effect of estrogen on the gland. These views did not afford a common basis for spontaneous and reflex ovulation.

Schweizer, Charipper and Haterius (1937) offered the first surmise of similarity, after finding that guinea pigs bearing intra-ocular pituitary grafts developed persistent estrus and large follicles that failed to go through maturation changes. Their feeling was that the normal connection of hypophysis with hypothalamus may be necessary for cyclic liberation of LH. Almost concurrently, Dempsey (1937) expressed a similar view as one alternative explanation of his experimental results with the guinea pig cycle. Suggesting cautiously that release of luteinizer may be brought about by a "rhythmic discharge" from the central nervous system, he went on to mention the "possibility that a high level of oestrin is necessary but not *directly* responsible for the release of luteinizer" (italics added). From this it is only a short transition to certain concepts set forth in the present exposition.

According to current views: (1) Reflex ovulation and spontaneous ovulation alike are governed by a hypothalamo-pituitary



apparatus whose final link to the pituitary is neurohumoral by way of the hypophyseal portal veins and whose activity precipitates release of LH. (2) The apparatus includes a hypothalamic center or centers whose excitation depends on estrogen-progesterone levels and afferent impulses of various kinds. (3) The sensitivity of the center(s) is influenced not only by the sex steroids, but by other poorly understood factors that vary from species to species and from time to time in individuals, *e.g.*, the diurnal rhythm in rats. Here in bare outline is a plausible hypothesis that may be generally applied to the events immediately relating to ovulation.

Satisfactory hypotheses respecting other phases of the cycle must await future developments. The extent and manner of intervention of the nervous system in the follicular and luteal phases remain unsettled. Although the hypophyseal hormones concerned in ovarian follicle development have been characterized, their exact chemical description has not been accomplished. The rate of their output at different stages of the cycle is largely a matter of conjecture. Structural changes that they produce in the ovary are well known, but in chemical terms only the end products of ovarian activity are well recognized, and these probably incompletely. The fact that the estrogens, in turn, have a regulating effect on follicle-stimulating activity of the hypophysis is known, but the mechanisms by which this effect is accomplished are uncertain. The hypophyseal hormones that maintain the luteal phase are recognized with any certainty in only three species and there is a wide difference between rabbits, on the one hand, and rats and mice, on the other. For mammals generally, the luteotropic factors have not been identified. Whether the hypothalamus is actively concerned in maintenance of the luteal phase in the majority of mammals is unknown. The morphologic effects of luteotropic stimulation on corpora lutea are well recognized, but here again the chemical mechanisms leading to the end products are obscure. The action of the corpus luteum hormone in regulation of the cycle is partially known, including the well established fact that its continual presence in large amount will suppress the estrogenic and

ovulatory phases. Yet, one cannot say whether this effect is accomplished by direct action on the hypophysis or by indirect action through the central nervous system. Nor can one state how the hypophysis-gonad equilibrium of the luteal phase is interrupted in the absence of a conceptus. With respect to the ovulation mechanism itself, the hypothesis outlined above requires verification in additional species. Assuming its validity, many details remain to be studied, *e.g.*, the neural pathways and nuclei involved, identification of neurochemical activators of the pars distalis and their sources and loci of action, the precise nature of mechanisms whereby the gonadal steroids excite or suppress, the cellular mechanisms by which ovulating hormone is released into circulation by the hypophysis, and the cytochemical effects within the ovary. All too evidently an encompassing theory of the female reproductive cycle is far from realization.

## IX. References

- ALLEN, E., DANFORTH, C. H., AND DOISY, E. A., Eds. 1939. *Sex and Internal Secretions*, 2nd ed. Baltimore: The Williams & Wilkins Company.
- ALLEN, E. 1923. Racial and familial cyclic inheritance and other evidence from the mouse concerning the cause of estrous phenomena. *Am. J. Anat.*, **32**, 293-304.
- ALLEN, E. 1927. The menstrual cycle of the monkey, *Macacus rhesus*: observations on normal animals, the effects of removal of the ovaries and the effects of injection of ovarian and placental extracts into the spayed animals. *Contr. Embryol.*, Carnegie Inst. Washington, **19**, 1-14.
- ALLEN, E., PRATT, J. P., NEWELL, Q. U., AND BLAND, L. J. 1930. Human ova from large follicles: including a search for maturation divisions and observations of atresia. *Am. J. Anat.*, **46**, 1-53.
- ALLOTEAU, J. J. 1952. La lordose réflexe par excitation du col utérin chez la rate. Son contrôle endocrinien. *Compt. rend. Soc. biol.*, **146**, 237-238.
- ALLOTEAU, J. J. 1954. Effets de doses minimes de progestérone sur les fonctions gonadotropes de la Ratte en oestrus permanent hypothalamique. *Compt. rend. Soc. biol.*, **148**, 875-877.
- ALLOTEAU, J. J., AND COURVOISIER, B. 1953. Effets de l'excitation du col utérin chez la rate après lésions hypothalamique. *Compt. rend. Soc. biol.*, **147**, 1040-1042.
- ARMSTRONG, D. T., AND HANSEL, W. 1958. Alteration of the bovine estrous cycle with oxytocin. *Fed. Proc.*, **17**, 6.
- ARON, C., AND ARON-BRUNETIÈRE, R. 1953. *Recher-*

- de la stimulation mécanique du vagin et du segment supracervical de l'utérus sur l'ovaire de Cobaye. *Compt. rend. Acad. Sc.*, **237**, 846-848.
- ASHEHEIM, P. 1954. Influence du tissu décidual sur la pseudogestation provoquée par l'administration de prolactine chez le rat. *Compt. rend. Soc. biol.*, **148**, 185-187.
- ASCHNER, B. 1909. Demonstration von Hünden nach Extirpation der Hypophysis. *Wien. klin. Wchnschr.*, **22**, 1730-1732.
- ASELL, S. A. 1946. *Patterns of Mammalian Reproduction*. Ithaca, N. Y.: Comstock Publishing Company.
- ASELL, S. A., AND HAMMOND, J. 1933. The effects of prolonging the life of the corpus luteum in the rabbit by hysterectomy. *Am. J. Physiol.*, **103**, 600-605.
- ASTWOOD, E. B. 1939. Changes in weight and water content of the uterus of the normal adult rat. *Am. J. Physiol.*, **126**, 162-170.
- ASTWOOD, E. B. 1941. The regulation of corpus luteum function by hypophysial luteotrophin. *Endocrinology*, **28**, 309-320.
- ASTWOOD, E. B., AND FEVOLD, H. L. 1939. Action of progesterone on the gonadotropic activity of the pituitary. *Am. J. Physiol.*, **127**, 192-198.
- BACHMAN, C. 1936. Oestrogenic hormone and the mechanism of corpus luteum formation in the rabbit. *Proc. Soc. Exper. Biol. & Med.*, **33**, 551-554.
- BACQ, Z. M. 1932. Effect of sympathectomy on sexual functions, lactation and maternal behavior in the albino rat, with a description of the technique of sympathectomy in the rat. *Am. J. Physiol.*, **99**, 444-453.
- BAIN, J. A. 1952. Enzymatic aspects of barbiturate action. *Fed. Proc.*, **11**, 653-658.
- BALL, J. 1934. Demonstration of quantitative relation between stimulus and response in pseudopregnancy in the rat. *Am. J. Physiol.*, **107**, 698-703.
- BALL, J., AND HARTMAN, C. G. 1939. A case of delayed ovulation after estrin administration in the intact monkey. *Proc. Soc. Exper. Biol. & Med.*, **40**, 629-631.
- BARBAROSSA, C., AND DI FERRANTE, H. 1950. Sugli effetti dell'ipofisectomia nel correlazione intermedia-ovario. *Arch. "E. Merigliano" pat. e clin.*, **5**, 887-890.
- BARRELOUGH, C. A. 1955. Blockade of the release of pituitary gonadotrophin by reserpine. *Fed. Proc.*, **14**, 9-10.
- BARRELOUGH, C. A. 1956. Blockade of the release of pituitary gonadotrophin by chlorpromazine. *Anat. Rec.*, **124**, 255.
- BARRELOUGH, C. A. 1957. Induction of pseudopregnancy in the rat by reserpine and chlorpromazine. *Anat. Rec.*, **127**, 262-263.
- BARRELOUGH, C. A., AND SAWYER, C. H. 1955. Inhibition of the release of pituitary ovulatory hormone in the rat by morphine. *Endocrinology*, **57**, 329-337.
- BARRETT, R. J., AND GREEP, R. O. 1951. The direction of flow in the blood vessels of the infundibular stalk. *Science*, **113**, 185.
- BARTELMEZ, G. W., CORNER, G. W., AND HARTMAN, C. G. 1951. Cyclic changes in the endometrium of the rhesus monkey (*Macaca mulatta*). *Contr. Embryol.*, Carnegie Inst. Washington, **34**, 99-144.
- BAUER, H. G. 1954. Endocrine and other clinical manifestations of hypothalamic disease. *J. Clin. Endocrinol.*, **14**, 13-31.
- BEARD, J. 1898. The rhythm of reproduction in animals. *Anat. Abz.*, **14**, 97-102.
- BENOIT, J., AND ASSENMACHER, E. 1955. Le contrôle hypothalamique de l'activité préhypophysaire gonadotrope. *J. Physiol.*, Paris, **47**, 427-567.
- BENSON, G. K., AND FOLLEY, S. J. 1956. Oxytocin as stimulator for the release of prolactin from the anterior pituitary. *Nature*, London, **177**, 700.
- BIELSCHOWSKY, F., AND HALL, W. H. 1953. The endocrine imbalance induced in female rats by autotransplantation of the ovary into the tail. *Australian J. Exper. Biol. & Med. Sc.*, **31**, 85-98.
- BISKIND, G. R. 1941. The inactivation of estradiol and estradiol benzoate in castrate female rats. *Endocrinology*, **28**, 894-896.
- BLANDAUF, R. J., AND MONEY, W. L. 1943. The attainment of sexual maturity in the female albino rat as determined by the copulatory response. *Anat. Rec.*, **86**, 197-215.
- BLOCH, K. 1945. Biological conversion of cholesterol to pregnanediol. *J. Biol. Chem.*, **157**, 661-666.
- BOLING, J. L. 1942. Growth and regression of corpora lutea during the normal estrous cycle of the rat. *Anat. Rec.*, **82**, 131-145.
- BOLING, J. L., BLANDAUF, R. J., RUNBLETT, B., AND YOUNG, W. C. 1941. Factors underlying the failure of cyclic mating behavior in the albino rat. *Anat. Rec.*, **80**, 155-171.
- BORELL, U., WESTMAN, A., AND ÖRSTRÖM, Å. 1947. Studies on the functions of the hypophysial-dienecephalic system and of the ovaries by means of radioactive phosphorus. *Gynaecologia*, **123**, 186-200.
- BORELL, U., WESTMAN, A., AND ÖRSTRÖM, Å. 1948. The phosphate metabolism in the hypophysial-dienecephalic system and ovaries of rats determined by means of  $P^{32}$ . *Acta physiol. scandinav.*, **15**, 245-253.
- BORELL, U., AND WESTMAN, A. 1949. The effect of oestrogen on the phosphate turnover in the hypophysial-dienecephalic system. *Acta endocrinol.*, **3**, 111-118.
- BOURNE, G., AND ZUCKERMAN, S. 1941. Changes in the adrenals in relation to the normal and artificial threshold oestrous cycle in the rat. *J. Endocrinol.*, **2**, 283-310.
- BRADBURY, J. T. 1937. Prolongation of the life of the corpus luteum by hysterectomy in the rat. *Anat. Rec.*, **70**, Suppl. 1, 51.
- BRADBURY, J. T. 1940. Observations following the cessation of treatment of the infantile female rat with androgens and gonadotropic extracts. *Am. J. Physiol.*, **129**, P315.
- BRADBURY, J. T. 1941. Permanent after-effects

- following masculinization of the infantile female rat. *Endocrinology*, **28**, 101-106.
- BRADBURY, J. T. 1947. Ovarian influence on the response of the anterior pituitary to estrogens. *Endocrinology*, **41**, 501-513.
- BRADBURY, J. T., BROWN, W. E., AND GRAY, L. A. 1950. Maintenance of the corpus luteum and physiologic actions of progesterone. *Recent Progr. Hormone Res.*, **5**, 151-194.
- BRAMBELL, F. W. R., PARKES, A. S., AND FIELDING, U. 1927a. Changes in the ovary of the mouse following exposure to X-rays. I. Irradiation at three weeks old. *Proc. Roy. Soc. London, ser. B*, **101**, 29-56.
- BRAMBELL, F. W. R., PARKES, A. S., AND FIELDING, U. 1927b. Changes in the ovary of the mouse following exposure to X-rays. II. Irradiation at or before birth. *Proc. Roy. Soc., London, ser. B*, **101**, 95-114.
- BROOKS, C. McC. 1937. The rôle of the cerebral cortex and of various sense organs in the excitation and execution of mating activity in the rabbit. *Am. J. Physiol.*, **120**, 544-553.
- BROOKS, C. McC. 1938. A study of the mechanism whereby coitus excites the ovulation producing activity of the rabbit's pituitary. *Am. J. Physiol.*, **121**, 157-177.
- BROUHA, L., AND SIMONNET, H. 1930. Considérations sur le déterminisme du cycle ovarien chez les Mammifères. In *Proceedings 2nd International Congress Sex Research*, pp. 339-344. Edinburgh: Oliver & Boyd.
- BROWMAN, L. G. 1937. Light in its relation to activity and estrus rhythms in the albino rat. *J. Exper. Zool.*, **75**, 375-388.
- BROWN, W. E., AND BRADBURY, J. T. 1947. Estrogen release of pituitary gonadotropin in women. *Tr. Conference Sterility & Infertility. Am. Soc. Stud. Steril.*, **3**, 117-124.
- BROWN, W. E., BRADBURY, J. T., AND JENNINGS, A. F. 1948. Experimental alteration of the human ovarian cycle by estrogen. *J. Clin. Endocrinol.*, **8**, 453-460.
- BRYANS, F. E. 1951. Progesterone of the blood in the menstrual cycle of the monkey. *Endocrinology*, **48**, 733-740.
- BUNN, J. P., AND EVERETT, J. W. 1957. Ovulation in persistent-estrous rats after electrical stimulation of the brain. *Proc. Soc. Exper. Biol. & Med.*, **96**, 369-371.
- BURFORD, T. H., AND DIDDLE, A. W. 1936. Effect of total hysterectomy upon the ovary of *Macacus rhesus*. *Surg. Gynec. & Obst.*, **62**, 701-707.
- BURRILL, M. W., AND GREENE, R. R. 1941. Androgen production in the female rat. *Endocrinology*, **28**, 871-873.
- BUXTON, C. L., AND ENGLE, E. T. 1950. Time of ovulation: a correlation between basal temperature, the appearance of the endometrium and the appearance of the ovary. *Am. J. Obst. & Gynec.*, **60**, 539-551.
- BYRNES, W. W., AND MEYER, R. K. 1951a. The inhibition of gonadotrophic hormone secretion by physiological doses of estrogen. *Endocrinology*, **48**, 133-136.
- BYRNES, W. W., AND MEYER, R. K. 1951b. Effect of physiological amounts of estrogen on the secretion of follicle-stimulating and luteinizing hormones. *Endocrinology*, **49**, 449-460.
- CANIVENC, R., AND MAYER, G. 1953. Les corps gestatifs de la rate sont-ils prolongés par la prolactine? Etude de l'accouchement et de l'ablation des cornes gravides au cours de la lactation prolongée. *Compt. rend. Soc. biol.*, **147**, 2025-2027.
- CASIDA, L. E. 1946. Induction of ovulation and subsequent fertility in domestic animals. In *The Problem of Fertility*, E. T. Engle, Ed., pp. 49-59. Princeton, N. J.: Princeton University Press.
- CHRISTIAN, C. D. 1956. Studies on the neuroendocrine control of ovulation in the rabbit. Dissertation, Duke University.
- CHRISTIAN, C. D., MARKEE, S. J., AND MARKEE, J. E. 1955. Failure of spinal cord transection to prevent ovulation following hypothalamic stimulation in the rabbit. *Anat. Rec.*, **121**, 275.
- CLAESSON, L., AND HILLARP, N.-Å. 1947a. The formation mechanism of oestrogenic hormones. I. The presence of an oestrogen-precursor in the rabbit ovary. *Acta physiol. scandinav.*, **13**, 115-129.
- CLAESSON, L., AND HILLARP, N.-Å. 1947b. The formation mechanism of oestrogenic hormones. II. The presence of oestrogen precursor in the ovaries of rats and guinea-pigs. *Acta physiol. scandinav.*, **14**, 102-119.
- CLARK, H. M. 1935. A prepubertal reversal of the sex difference in the gonadotropic hormone content of the pituitary gland of the rat. *Anat. Rec.*, **61**, 175-192.
- COLE, H. H. 1946. Estrogen in late pregnancy mare serum and ovarian inhibition. *Endocrinology*, **39**, 177-182.
- COLE, H. H., AND MILLER, R. F. 1935. Changes of the reproductive organs of the ewe with some data bearing on their control. *Am. J. Anat.*, **57**, 39-97.
- CONSTANTINES, P. 1947. Progesterone secretion during the oestrous cycle of the unmated rat. *J. Endocrinol.*, **5**, lxiv.
- COFFEDGE, R. L., AND SEGALOFF, A. 1951. Urinary prolactin excretion in man. *J. Clin. Endocrinol.*, **11**, 465-476.
- CORNER, G. W. 1937. The rate of secretion of progesterin by the corpus luteum. *Cold Spring Harbor Symposia Quant. Biol.*, **5**, 62-65.
- CORNER, G. W. 1938. The sites of formation of estrogenic substances in the animal body. *Physiol. Rev.*, **18**, 154-172.
- CORNER, G. W. 1940. Rate of secretion of estrogenic hormones by the ovaries of the monkey, *Macacus rhesus*. *Bull. Johns Hopkins Hosp.*, **67**, 407-413.
- CORNER, G. W. 1942. *The Hormones in Human Reproduction*. Princeton, N. J.: Princeton University Press.
- COURRIER, R. 1956. Remarque sur la greffe d'hypophyse. *Arch. Biol. Paris*, **67**, 461-469.
- CRITCHLOW, B. V., AND SAWYER, C. H. 1955. Electrical activity of the rat brain correlated with

- neurogenic stimulation of the adenohypophysis. Fed. Proc., **14**, 32-33.
- CHOWE, S. J., CUSHING, H., and HOMANS, J. 1910. Experimental hypophysectomy. Bull. Johns Hopkins Hosp., **21**, 127-169.
- CUTLIP, E. 1941a. Autoplastic grafting of the anterior pituitary in male rats. Anat. Rec., **80**, 83-97.
- CUTLIP, E. 1941b. Studies on the histology and physiology of the pituitary of rats treated with progesterone. Endocrinology, **29**, 695-701.
- D'AMOUR, F. 1940. Further studies on hormone excretion during the menstrual cycle. Am. J. Obst. & Gynec., **40**, 958-965.
- DANDY, W. E. 1940. Section of the human hypophysial stalk. J. A. M. A., **114**, 312-314.
- DAVIS, C. D. 1939. The effect of ablations of neocortex on mating, maternal behavior and the production of pseudopregnancy in the female rat and on copulatory activity in the male. Am. J. Physiol., **127**, 374-380.
- DAVIS, M. E., and FUGO, N. W. 1948. Does administration of diethylstilbestrol to pregnant women result in increased output of urinary pregnanediol? Proc. Soc. Exper. Biol. & Med., **69**, 436-438.
- DEANESLY, R. 1934. The reproductive processes of certain mammals. VI. The reproductive cycle of the female hedgehog. Phil. Tr. Roy. Soc., London, ser. B, **223**, 239-276.
- DEANESLY, R. 1938. The androgenic activity of ovarian grafts in castrated male rats. Proc. Roy. Soc., London, ser. B, **126**, 122-135.
- DEANESLY, R., and PARKES, A. S. 1933. The effect of hysterectomy on the oestrous cycle of the ferret. J. Physiol., **78**, 80-84.
- DEL CASTILLO, E. B., and CALATHRONI, C. J. 1930. Cycle sexual périodique et folliculine. Compt. rend. Soc. biol., **104**, 1024-1028.
- DEL CASTILLO, E. B., and DI PAOLA, G. 1942. Cyclical vaginal response to the daily administration of estradiol in castrated rats. Endocrinology, **30**, 48-53.
- DEMPSEY, E. W. 1937. Follicular growth rate and ovulation after various experimental procedures in the guinea pig. Am. J. Physiol., **120**, 126-132.
- DEMPSEY, E. W. 1939. The relationship between the central nervous system and the reproductive cycle in the female guinea pig. Am. J. Physiol., **126**, 758-765.
- DEMPSEY, E. W., HERTZ, R., and YOUNG, W. C. 1936. The experimental induction of oestrus (sexual receptivity) in the normal and ovariectomized guinea pig. Am. J. Physiol., **116**, 201-209.
- DEMPSEY, E. W., and COTILA, U. U. 1940. The effect of pituitary stalk section upon reproductive phenomena in the female rat. Endocrinology, **27**, 573-579.
- DEMPSEY, E. W., and SEARLES, H. F. 1943. Environmental modification of certain endocrine phenomena. Endocrinology, **32**, 119-128.
- DESCLIN, L. 1935. Action de fortes doses d'hormone folliculaire sur la structure de l'ovaire et du lobe antérieur de l'hypophyse chez le rat blanc. Compt. rend. Soc. biol., **120**, 526-528.
- DESCLIN, L. 1948. Action de la prolactine sur la structure de l'ovaire du rat normale et hypophysectomisé. Compt. rend. Soc. biol., **142**, 1436-1438.
- DESCLIN, L. 1949a. Action des oestrogènes sur l'ovaire chez le rat normal et hypophysectomisé. Compt. rend. Soc. biol., **143**, 1004-1006.
- DESCLIN, L. 1949b. A propos de l'action combinée de la prolactine et des oestrogènes sur la structure de l'ovaire chez le rat. Compt. rend. Soc. biol., **143**, 1154-1155.
- DESCLIN, L. 1950. A propos du mécanisme d'action des oestrogènes sur le lobe antérieur de l'hypophyse chez le rat. Ann. endocrinol., **11**, 656-659.
- DESCLIN, L. 1956a. Hypothalamus et libération d'hormone lutéotrophique. Expériences de greffe hypophysaire chez le rat hypophysectomisé. Action lutéotrophique de l'oocytocine. Ann. endocrinol., **17**, 586-595.
- DESCLIN, L. 1956b. L'oocytocine peut-elle déclencher la libération de lutéotrophine hypophysaire chez le rat? Compt. rend. Soc. biol., **150**, 1488-1491.
- DEY, F. L. 1941. Changes in ovaries and uteri in guinea pigs with hypothalamic lesions. Am. J. Anat., **69**, 61-87.
- DEY, F. L. 1943. Evidence of hypothalamic control of hypophysal gonadotropic function in the female guinea pig. Endocrinology, **33**, 75-82.
- DEY, F. L., FISHER, C., BERRY, C. M., and RANSON, S. W. 1940. Disturbances in reproductive functions caused by hypothalamic lesions in female guinea pigs. Am. J. Physiol., **129**, 39-46.
- DIAZ, J. T. 1940. Effect of subtotal nephrectomy upon the oestrous cycle of the albino rat. Proc. Soc. Exper. Biol. & Med., **45**, 226-229.
- DONOVAN, B. T., and HARRIS, G. W. 1954. Effect of pituitary stalk section on light-induced oestrus in the ferret. Nature, London, **174**, 503-504.
- DONOVAN, B. T., and HARRIS, G. W. 1956. Adrenergic agents and the release of gonadotrophic hormone in the rabbit. J. Physiol., **132**, 577-585.
- DONOVAN, B. T., and VAN DER WERFF TEN BOSCH, J. J. 1956. Oestrus in winter following hypothalamic lesions in the ferret. J. Physiol., **132**, 57P.
- DORDONI, F., and TIMIRAS, P. S. 1952. Inhibitory action of stress on the release of luteinizing hormone by estrogen in the rat. J. Pharmacol. & Exper. Therap., **106**, 381-382.
- DORFMAN, R. I., and VAN WAGENEN, G. 1941. The sex hormone excretion of adult female and pregnant monkeys. Surg. Gynec. & Obst., **73**, 545-548.
- DÖRING, G. K., and GÖZ, E.-M. 1952. Über die Wirkung des Zwischenhirnmarkotiums Luminal auf den Scheidencyclus der weissen Ratte. Arch. Gynäk., **181**, 185-189.
- DRIS, D. G., and FORD, F. A. 1932. The effect of

- X-rays on the estrual cycle and ovaries of the white rat. *Surg. Gynec. & Obst.*, **55**, 596-606.
- DUTT, R. H., AND CASIDA, L. E. 1948. Alteration of the estrual cycle in sheep by use of progesterone and its effect upon subsequent ovulation and fertility. *Endocrinology*, **43**, 208-217.
- DUYVENÉ DE WIT, J. J. 1942. Presence of progesterone and 17-ketosteroids in the follicular fluid of the pig, cow, and human being. *Acta brev. neerl.*, **12**, 23-25.
- EDGAR, D. G. 1952. Progesterone in body fluids. *Nature, London*, **170**, 543-544.
- EDGAR, D. G. 1953. The progesterone content of body fluids and tissues. *J. Endocrinol.*, **10**, 54-64.
- EDGAR, D. G., AND RONALDSON, J. W. 1958. Blood levels of progesterone in the ewe. *J. Endocrinol.*, **16**, 378-384.
- EMMENS, C. W. 1939. The duration of action of certain natural and synthetic oestrogens when administered orally or by injection. *J. Endocrinol.*, **1**, 142-146.
- ENGLE, E. T. 1931. The pituitary gonadal relationship and the problem of precocious sexual maturity. *Endocrinology*, **15**, 405-420.
- ENGLE, E. T. 1946. No seasonal breeding cycle in dogs. *J. Mammal.*, **27**, 79-81.
- ENGLE, E. T., AND SHIELESNYAK, M. C. 1934. First menstruation and subsequent menstrual cycles of pubertal girls. *Human Biol.*, **6**, 431-453.
- ERSHOFF, B. H., AND DUELL, H. J., JR. 1943. Prolongation of pseudopregnancy by induction of decidualoma in the rat. *Proc. Soc. Exper. Biol. & Med.*, **54**, 167-168.
- EVANS, H. M., AND LONG, J. A. 1921. On the association of continued cornification of the vaginal mucosa with the presence of large vesicles in the ovary and the absence of corpus luteum formation. *Anat. Rec.*, **21**, 60-61.
- EVANS, H. M., AND COLE, H. H. 1931. An introduction to the study of the oestrous cycle in the dog. *Mem. Univ. California*, **9**, 67-117.
- EVANS, H. M., AND SWEZY, O. 1931. Ovogenesis and the normal follicular cycle in adult mammalia. *Mem. Univ. California*, **9**, 119-225.
- EVANS, H. M., SIMPSON, M. E., LYONS, W. R., AND TURPEINEN, K. 1941. Anterior pituitary hormones which favor the production of traumatic uterine placentomata. *Endocrinology*, **28**, 933-945.
- EVERETT, J. W. 1939. Spontaneous persistent estrus in a strain of albino rats. *Endocrinology*, **25**, 123-127.
- EVERETT, J. W. 1940a. The restoration of cyclic estrus and ovulation in persistent-estrous rats by progesterone. *Anat. Rec.*, **76**, No. 2, Suppl., 21.
- EVERETT, J. W. 1940b. The restoration of ovulatory cycles and corpus luteum formation in persistent-estrous rats by progesterone. *Endocrinology*, **27**, 681-686.
- EVERETT, J. W. 1942a. Certain functional interrelationships between spontaneous persistent estrus, "light estrus" and short-day anestrus in the albino rat. *Anat. Rec.*, **82**, 409.
- EVERETT, J. W. 1942b. Hereditary factors which condition the "light estrus" response in the albino rat. *Anat. Rec.*, **82**, 463.
- EVERETT, J. W. 1943. Further studies on the relationship of progesterone to ovulation and luteinization in the persistent-estrous rat. *Endocrinology*, **32**, 285-292.
- EVERETT, J. W. 1944a. Evidence in the normal albino rat that progesterone facilitates ovulation and corpus-luteum formation. *Endocrinology*, **34**, 136-137.
- EVERETT, J. W. 1944b. Evidence suggesting a role of the lactogenic hormone in the estrous cycle of the albino rat. *Endocrinology*, **35**, 507-520.
- EVERETT, J. W. 1945. The microscopically demonstrable lipids of cyclic corpora lutea in the rat. *Am. J. Anat.*, **77**, 293-323.
- EVERETT, J. W. 1947. Hormonal factors responsible for deposition of cholesterol in the corpus luteum of the rat. *Endocrinology*, **41**, 364-377.
- EVERETT, J. W. 1948. Progesterone and estrogen in the experimental control of ovulation time and other features of the estrous cycle in the rat. *Endocrinology*, **43**, 389-405.
- EVERETT, J. W. 1952a. Presumptive hypothalamic control of spontaneous ovulation. *Ciba Foundation Colloquia Endocrinol.*, **4**, 167-176.
- EVERETT, J. W. 1952b. Factors affecting the success of pharmacological blockade of ovulation in rats. *J. Clin. Endocrinol.*, **12**, 923.
- EVERETT, J. W. 1954. Lutetrophic function of autografts of the rat hypophysis. *Endocrinology*, **54**, 685-690.
- EVERETT, J. W. 1956a. Functional corpora lutea maintained for months by autografts of rat hypophyses. *Endocrinology*, **58**, 786-796.
- EVERETT, J. W. 1956b. The time of release of ovulating hormone from the rat hypophysis. *Endocrinology*, **59**, 580-585.
- EVERETT, J. W. 1956c. Maintenance of pregnancy in rats by hypophyseal autografts. *Anat. Rec.*, **124**, 287-288.
- EVERETT, J. W., AND SAWYER, C. H. 1949. A neural timing factor in the mechanism by which progesterone advances ovulation in the cyclic rat. *Endocrinology*, **45**, 581-595.
- EVERETT, J. W., AND SAWYER, C. H. 1950. A 24-hour periodicity in the "LH-release apparatus" of female rats, disclosed by barbiturate sedation. *Endocrinology*, **47**, 198-218.
- EVERETT, J. W., AND SAWYER, C. H. 1953. Estimated duration of the spontaneous activation which causes release of ovulating hormone from the rat hypophysis. *Endocrinology*, **52**, 83-92.
- EVERETT, J. W., SAWYER, C. H., AND MARKEE, J. E. 1949. A neurogenic timing factor in control of the ovulatory discharge of luteinizing hormone in the cyclic rat. *Endocrinology*, **44**, 234-250.
- FEE, A. R., AND PARKES, A. S. 1929. Studies on ovulation. I. The relation of the anterior

- pituitary body to ovulation in the rabbit. *J. Physiol.*, **67**, 383-388.
- FRANK, E. 1952. Die Unterbindung des Ovarienstüdes als Ursach anatomischer und funktioneller Genitalstörungen. *Arch. Gynäk.*, **181**, 380-390.
- FINERTY, J. C. 1952. Parabiosis in physiological studies. *Physiol. Rev.*, **32**, 277-302.
- FISHL, W. R., YOUNG, W. C., AND DORFMAN, R. I. 1941. Excretion of estrogenic and androgenic substances by male and female chimpanzees with known mating behavior records. *Endocrinology*, **28**, 585-592.
- FISKE, V. M. 1941. Effect of light on sexual maturation, estrous cycles, and anterior pituitary of the rat. *Endocrinology*, **29**, 187-196.
- FLERKÓ, B. 1951. Zur hypothalamischen Steuerung der gonadotropen Funktion der Hypophyse. *Acta morphol.*, **4**, 475-492.
- FLERKÓ, B. 1957a. Einfluss experimenteller Hypothalamusläsion auf die durch Follikelhormon indirekt hervorgerufene Hemmung der Luteinisation. *Endokrinologie*, **34**, 201-208.
- FLERKÓ, B. 1957b. Le rôle des structures hypothalamiques dans l'action inhibitrice de la folliculine sur la sécrétion de l'hormone folliculo-stimulante. *Arch. Anat. microscop. Morphol. expér.*, **46**, 159-172.
- FLERKÓ, B. AND ILLI, G. 1957. Zur Frage der Spezifität des Einflusses von Sexualsteroiden auf hypothalamische Nervenstrukturen. *Endokrinologie*, **35**, 123-127.
- FLERKÓ, B. AND SZENTGOTTHAL, J. 1957. Oestrogen sensitive nervous structures in the hypothalamus. *Acta endocrinol.*, **26**, 121-127.
- FLUCHMANN, C. F. 1934. A new procedure for the demonstration of estrin in the blood of women. *Endocrinology*, **18**, 705-713.
- FLUCHMANN, C. F. 1952. Induction of precocious opening of immature rat vagina with neostigmine. *Proc. Soc. Exper. Biol. & Med.*, **81**, 315-317.
- FORBES, T. R. 1950. Systemic plasma progesterone levels during the human menstrual cycle. *Am. J. Obst. & Gynec.*, **60**, 180-186.
- FORBES, T. R. 1953. Pre-ovulatory progesterone in the peripheral blood of the rabbit. *Endocrinology*, **53**, 79-87.
- FORBES, T. R., HOOKER, C. W., AND PEIFFER, C. A. 1950. Plasma progesterone levels and the menstrual cycle of the monkey. *Proc. Soc. Exper. Biol. & Med.*, **73**, 177-179.
- FORD, D. H., AND YOUNG, W. C. 1953. Duration of the first cyclic vaginal openings in maturing guinea pigs and related ovarian conditions. *Anat. Rec.*, **115**, 495-503.
- FOSTER, M. A. 1931. The reproductive cycle in the female ground squirrel, *Citellus tridecemlineatus* (Mitchell). *Am. J. Anat.*, **54**, 487-511.
- FOSTER, M. A., HANEY, H. F., AND HISAW, F. L. 1934. Parasympathetic drugs and ovulation. *Proc. Soc. Exper. Biol. & Med.*, **32**, 351-353.
- FOSTER, M. A., AND HISAW, F. L. 1935. Experimental ovulation and the resulting pseudo-pregnancy in aseasonal cats. *Anat. Rec.*, **62**, 75-93.
- FRANKEL-CORRAT, H., LI, C. H., AND SIMPSON, M. E. 1943. Pituitary gonadotropins. In *Essays in Biology*, pp. 183-191. Berkeley: University of California Press.
- FRANK, R. T., KINGERY, H. M., AND GUSTAVSON, R. G. 1925. The female sex hormone. II. An analysis of factors producing puberty. *J. A. M. A.*, **85**, 1558-1559.
- FRAPS, R. M., AND CASE, J. F. 1953. Premature ovulation in the domestic fowl following administration of certain barbiturates. *Proc. Soc. Exper. Biol. & Med.*, **82**, 167-171.
- FRAPS, R. M., AND DRY, A. 1943. Occurrence of premature ovulation in the domestic fowl following administration of progesterone. *Proc. Soc. Exper. Biol. & Med.*, **52**, 346-349.
- FREED, S. C., GREENHILL, J. P., AND SOSKIN, S. 1938. Biphasic effect of male sex hormone on the pituitary of the female rat. *Proc. Soc. Exper. Biol. & Med.*, **39**, 440-442.
- FRIED, P. H., AND RAKOFF, A. E. 1952. The effects of chorionic gonadotropin and prolactin on the maintenance of corpus luteum function. *J. Clin. Endocrinol.*, **12**, 321-337.
- FRIEDGOOD, H. B., AND BEVIN, S. 1941. Relation of the cervical sympathetics to anterior pituitary gonadotrophic activity in the rat. *Am. J. Physiol.*, **133**, P282.
- FRIEDMAN, M. H. 1941. The inhibition of copper-induced ovulation in the rabbit by progesterone. *Endocrinology*, **29**, 628-632.
- FUGO, N. W., AND GROSS, E. G. 1942. Anterior pituitary-stimulating action of yohimbine. *Endocrinology*, **31**, 529-534.
- FUNNELL, J. W., KEATY, C., AND HELLBAUM, A. A. 1951. Action of estrogens on release of luteinizing hormone in menopausal women. *J. Clin. Endocrinol.*, **11**, 98-102.
- GAMENSTROOM, J. H., AND DE JONGH, S. E. 1946. *Contribution to the Knowledge of the Influences of Gonadotropic and Sex Hormones on the Gonads of Rats*. New York: Elsevier Publishing Company.
- GASSNER, F. X. 1952. Some physiological and medical aspects of the gonadal cycle of domestic animals. *Recent Progr. Hormone Res.*, **7**, 165-208.
- GENTHER, I. T. 1931. Irradiation of the ovaries of guinea-pigs and its effect on the oestrous cycle. *Am. J. Anat.*, **48**, 99-137.
- GILLMAN, J. 1942. Temporary ovarian damage produced in baboons by single administrations of estradiol benzoate and progesterone in the first part of the cycle. *Endocrinology*, **30**, 61-70.
- GITSCH, E. 1952a. Über die Wirkung der Kastration auf den dienecephalen Azetylcholin gehalt und seine beeinflussung durch Pentothal. *Wien. klin. Wochschr.*, **64**, 710-711.
- GITSCH, E. 1952b. Über periodische, zum gonadalen Cyclus in Korrelation stehende Funktionsänderungen in Hypothalamus. *Arch. Gynäk.*, **182**, 52-57.
- GITSCH, E. 1958. Synergistic actions of meprobamate and an anticholinergic drug, Pathilon, on

- reproductive cycles in the rat. *Endocrinology*, **62**, 533-535.
- GITSCH, E., AND EVERETT, J. W. 1958. Influence of the anticholinergic drug, Pathilon, on the reproductive cycle of the female rat. *Endocrinology*, **62**, 400-409.
- GITSCH, E., AND REITINGER, J. 1953. Über die Wirkung exogener Hormone auf den Azetylcholingehalt des mittleren Hypothalamus der Ratte. *Zentralbl. Gynäk.*, **75**, 209-218; 373-376; 734-738.
- GOLDBERG, R. C., AND KNOBIL, E. 1957. Structure and function of intraocular hypophyseal grafts in the hypophysectomized male rat. *Endocrinology*, **61**, 742-752.
- GREEN, J. D. 1947. Vessels and nerves of the amphibian hypophysis. A study of the living circulation and of the histology of the hypophysial vessels and nerves. *Anat. Rec.*, **99**, 21-54.
- GREEN, J. D. 1951. The comparative anatomy of the hypophysis, with special reference to its blood supply and innervation. *Am. J. Anat.*, **88**, 225-311.
- GREEN, J. D., AND HARRIS, G. W. 1947. The neurovascular link between the neurohypophysis and adenohypophysis. *J. Endocrinol.*, **5**, 136-146.
- GREEN, J. D., AND HARRIS, G. W. 1949. Observation of the hypophysiportal vessels of the living rat. *J. Physiol.*, **108**, 359-361.
- GREENWALD, G. S. 1956. The reproductive cycle of the field mouse, *Microtus californicus*. *J. Mammal.*, **37**, 213-222.
- GREEP, R. O. 1936. Functional pituitary grafts in rats. *Proc. Soc. Exper. Biol. & Med.*, **34**, 754-755.
- GREEP, R. O. 1938. The effect of gonadotropic hormones on persisting corpora lutea in hypophysectomized rats. *Endocrinology*, **23**, 154-163.
- GREEP, R. O., AND BARNETT, R. J. 1951. The effect of pituitary stalk-section on the reproductive organs of female rats. *Endocrinology*, **49**, 172-181.
- GREEP, R. O., AND CHESTER JONES, I. 1950. Steroid control of pituitary function. *Recent Progr. Hormone Res.*, **5**, 197-261.
- GREEP, R. O., AND HISAW, F. L. 1938. Pseudopregnancies from electrical stimulation of the cervix in the diestrum. *Proc. Soc. Exper. Biol. & Med.*, **39**, 359-360.
- GREEP, R. O., VAN DYKE, H. B., AND CLOW, B. F. 1942. Gonadotropins of the swine pituitary. I. Various biologic effects of purified thylenkentrin (FSH) and pure metakentrin (ICSH). *Endocrinology*, **30**, 635-649.
- GREEP, M. A. 1953. The effect of progesterone on persistent vaginal estrus produced by hypothalamic lesions in the rat. *Endocrinology*, **53**, 380-390.
- GREULICH, W. W. 1934. Artificially induced ovulation in the cat. *Anat. Rec.*, **58**, 217-224.
- GROSVENOR, C. E., AND TURNER, C. W. 1958. Effects of oxytocin and blocking agents upon pituitary lactogen discharge in lactating rats. *Proc. Soc. Exper. Biol. & Med.*, **97**, 463-465.
- HALE, H. B. 1941. Functional and morphologic alterations of the reproductive system of the female rat following prepubertal treatment with estrogens. *Endocrinology*, **35**, 499-506.
- HAMMOND, J. 1946. The induction of ovulation in domestic animals. In *The Problem of Fertility*, E. T. Engle, Ed. Princeton, N. J.: Princeton University Press.
- HAMMOND, J., AND MARSHALL, F. H. A. 1930. Oestrous and pseudopregnancy in the ferret. *Proc. Roy. Soc., London, ser. B*, **105**, 607-629.
- HAMMOND, J., AND WALTON, A. 1931. Notes on ovulation and fertilization in ferrets. *J. Exper. Biol.*, **11**, 307-319.
- HAMMOND, J., JR. 1945. Induced ovulation and heat in anoestrous sheep. *J. Endocrinol.*, **4**, 169-180.
- HAMMOND, J., JR. 1952. Maintenance of grafted luteal tissue. *Nature, London*, **169**, 330-331.
- HAMMOND, J., JR. 1953. Photoperiodicity in animals: the role of darkness. *Science*, **117**, 389-391.
- HAMMOND, J., JR., AND BHATTACHARYA, P. 1944. Control of ovulation in the cow. *J. Agric. Sc.*, **34**, 1-15.
- HAMMOND, J., JR., HAMMOND, J., AND PARKES, A. S. 1942. Hormonal augmentation of fertility in sheep. I. Induction of ovulation, superovulation, and heat in sheep. *J. Agric. Sc.*, **32**, 308-323.
- HAMMOND, J., JR., AND ROBSON, J. M. 1951. Local maintenance of the rabbit corpus luteum with oestrogen. *Endocrinology*, **49**, 384-389.
- HANSEL, W., AND TRIMBERGER, G. W. 1951. Atropine blockage of ovulation in the cow and its possible significance. *J. Anim. Sci.*, **10**, 719-725.
- HANSEL, W., AND TRIMBERGER, G. W. 1952. The effect of progesterone on ovulation time in dairy heifers. *J. Dairy Sci.*, **35**, 65-70.
- HANSSON, A. 1947. The physiology of reproduction in mink (*Mustela vison*, Schreb.) with special reference to delayed implantation. Thesis, Stockholm.
- HARRIS, G. W. 1936. The induction of pseudopregnancy in the rat by electrical stimulation through the head. *J. Physiol.*, **88**, 361-367.
- HARRIS, G. W. 1937. Induction of ovulation in rabbits by electrical stimulation of the hypothalamo-hypophysial mechanism. *Proc. Roy. Soc., London, ser. B*, **122**, 374-394.
- HARRIS, G. W. 1948a. Neural control of the pituitary gland. *Physiol. Rev.*, **28**, 139-179.
- HARRIS, G. W. 1948b. Electrical stimulation of the hypothalamus and the mechanism of neural control of the adenohypophysis. *J. Physiol.*, **107**, 418-429.
- HARRIS, G. W. 1949. Regeneration of the hypophysi-portal vessels. *Nature, London*, **163**, 70.
- HARRIS, G. W. 1950a. Regeneration of the hypophysial portal vessels, after section of the hypophysial stalk, in the monkey (*Macaca rhesus*). *Nature, London*, **165**, 819.
- HARRIS, G. W. 1950b. Oestrous rhythm, 1950-1951

- pregnancy and the pituitary stalk in the rat. *J. Physiol.*, **111**, 347-360.
- HARRIS, G. W. 1955. *Neural Control of the Pituitary Gland*. London: Edward Arnold, Ltd.
- HARRIS, G. W., AND JACOBSON, D. 1952. Functional grafts of the anterior pituitary gland. *Proc. Roy. Soc. London, ser. B.* **139**, 263-276.
- HARRISON, R. J. 1948. The changes occurring in the ovary of the goat during the oestrous cycle and in early pregnancy. *J. Anat.*, **82**, 21-48.
- HARTMAN, C. G. 1932. Studies in the reproduction of the monkey, *Macacus (Pithecus) rhesus*, with special reference to menstruation and pregnancy. *Contr. Embryol.*, Carnegie Inst. Washington, **13**, 1-161.
- HARTMAN, C. G. 1936. *Time of Ovulation in Women*. Baltimore: The Williams & Wilkins Company.
- HARTMAN, C. G. 1944. Some new observations on the vaginal smear of the rat. *Yale J. Biol. & Med.*, **17**, 99-112.
- HASKINS, A. L., JR. 1950. Assay of circulating progesterone by ultraviolet spectroscopy. *Proc. Soc. Exper. Biol. & Med.*, **73**, 439-443.
- HATERIUS, H. O. 1933. Partial sympathectomy and induction of pseudopregnancy. *Am. J. Physiol.*, **103**, 97-103.
- HATERIUS, H. O. 1936. Reduction of litter size and maintenance of pregnancy in the oophorectomized rat: evidence concerning the endocrine rôle of the placenta. *Am. J. Physiol.*, **114**, 399-406.
- HATERIUS, H. O. 1937. Studies on a neurohypophysical mechanism influencing gonadotropic activity. *Cold Spring Harbor Symposia Quant. Biol.*, **5**, 280-288.
- HECHTER, O., FRAENKEL, M., LEV, M., AND SOSKIN, S. 1940. Influence of the uterus on the corpus luteum. *Endocrinology*, **26**, 680-683.
- HECKEL, G. P. 1942. The estrogen sparing effect of hysterectomy. *Surg. Gynec. & Obst.*, **75**, 379-390.
- HEMINGSEN, A. M., AND KRARUP, N. B. 1937. Rhythmic diurnal variations in the oestrous phenomena of the rat and their susceptibility to light and dark. *Kgl. Danske Vidensk. Selsk. Biol. Med.*, **13** (Nr. 7), 1-61.
- HERNANDEZ, T. 1943. Hormonal ambisexuality of ovarian grafts in female rats. *Am. J. Anat.*, **73**, 127-151.
- HEROLD, L., AND EFFEKEMANN, G. 1938. Die Bedeutung des vegetativen Nervensystems für die innersekretorische Funktion des Hypophysenvorderlappens. *Arch. Gynäk.*, **167**, 389-396.
- HIEBL, M. 1952. Brunnstzeitige Kernschwellung im Tuber cinereum der weissen Maus. *Morphol. Jahrb.*, **92**, 75-94.
- HIEBL, M. 1955. Das Verhalten einiger Hypothalamuskern der weissen Maus während verschiedener Entwicklungs- und Funktionsphasen des weiblichen Genitalapparates. *Ztschr. Zellforsch.*, **42**, 481-507.
- HILL, J. P., AND O'DONOGHUE, C. H. 1913. The reproductive cycle in the marsupial *Dasyurus vicirinus*. *Quart. J. Microscop. Sc.*, **59**, 133-174.
- HILL, M., AND PARKES, A. S. 1930a. The relation between the anterior pituitary body and the gonads. I. The factors concerned in the formation of the corpus luteum. *Proc. Roy. Soc., London, ser. B.* **107**, 30-38.
- HILL, M., AND PARKES, A. S. 1930b. On the relation between the anterior pituitary body and the gonads. II. The induction of ovulation in the anaestrous ferret. *Proc. Roy. Soc. London, ser. B.* **107**, 39-48.
- HILL, M., AND PARKES, A. S. 1933. Studies on the hypophysectomized ferret. VI. Comparison of the response to oestrin of anaestrous, ovariectomized and hypophysectomized ferrets. *Proc. Roy. Soc. London, ser. B.* **113**, 541-544.
- HILL, M., AND WHITE, W. E. 1933. The growth and regression of follicles in the oestrous rabbit. *J. Physiol.*, **80**, 174-178.
- HILL, R. T. 1934. Variation in the activity of the rabbit hypophysis during the reproductive cycle. *J. Physiol.*, **83**, 129-136.
- HILL, R. T. 1937a. Ovaries secrete male hormone. I. Restoration of the castrate type of seminal vesicle and prostate glands to normal by grafts of ovaries in mice. *Endocrinology*, **21**, 495-502.
- HILL, R. T. 1937b. Ovaries secrete male hormone. III. Temperature control of male hormone output by grafted ovaries. *Endocrinology*, **21**, 633-636.
- HILLARP, N.-Å. 1949. Studies on the localization of hypothalamic centres controlling the gonadotrophic function of the hypophysis. *Acta endocrinol.*, **2**, 11-23.
- HINSEY, J. C. 1937. The relation of the nervous system to ovulation and other phenomena of the female reproductive tract. *Cold Spring Harbor Symposia Quant. Biol.*, **5**, 269-279.
- HINSEY, J. C., AND MARKEE, J. E. 1933. Pregnancy following bilateral section of the cervical sympathetic trunks in the rabbit. *Proc. Soc. Exper. Biol. & Med.*, **31**, 270-271.
- HISAW, F. L. 1942. The interaction of the ovarian hormones in experimental menstruation. *Endocrinology*, **30**, 301-308.
- HISAW, F. L. 1944. The placental gonadotrophin and luteal function in monkeys (*Macaca mulatta*). *Yale J. Biol. & Med.*, **17**, 119-137.
- HISAW, F. L. 1947. Development of the Graafian follicle and ovulation. *Physiol. Rev.*, **27**, 95-119.
- HÖHLEWEG, W. 1931. Veränderungen des Hypophysenvorderlappens und des Ovariums nach Behandlungen mit grossen Dosen von Follikelhormon. *Klin. Wehnschr.*, **13**, 92-95.
- HÖHLEWEG, W. 1937. Männliche Wirkstoffe und Corpus luteum-Bildung. *Klin. Wehnschr.*, **16**, 586-587.
- HÖHLEWEG, W., AND CHAMORRO, A. 1937. Über die luteinisierende Wirkung des Follikelhormons durch Beeinflussung der luteogenen



- Hypophysenvorderlappensekretion. *Klin. Wehnschr.*, **16**, 196-197.
- HOHLWEG, W., AND DOHRN, M. 1932. Über die Beziehungen zwischen Hypophysenvorderlappen und Keimdrüsen. *Klin. Wehnschr.*, **11**, 233-235.
- HOHLWEG, W., AND JUNKMANN, K. 1932. Die hormonal-nervöse Regulierung der Funktion des Hypophysenvorderlappens. *Klin. Wehnschr.*, **11**, 321-323.
- HOLMSTROM, E. G., AND JONES, W. J. 1949. The experimental production of menorrhagia by administration of gonadotropins. *Am. J. Obst. & Gynec.*, **58**, 308-317.
- HOOKE, C. W., AND FORBES, T. R. 1947. A bio-assay for minute amounts of progesterone. *Endocrinology*, **41**, 158-169.
- HOUGH, W. H., BEARDEN, H. J., AND HANSEL, W. 1955. Further studies on factors affecting ovulation in the cow. *J. Anim. Sc.*, **14**, 739-745.
- HUSTON, T. M., AND NALBANDOV, A. V. 1953. Neurohumoral control of the pituitary in the fowl. *Endocrinology*, **52**, 149-156.
- IGLESIAS, R., LIPSCHUTZ, A., AND GUILLERMO, R. 1950. Experiments with the local action of oestrogen on the intrasplenic ovarian graft. *Endocrinology*, **46**, 414-419.
- JOHNSON, G. E., FOSTER, M. A., AND COCO, R. M. 1933. The sexual cycle of the thirteen-lined ground squirrel in the laboratory. *Tr. Kansas Acad. Sc.*, **36**, 250-269.
- KALLAS, H. 1929. Sur le passage de substances hypophysaires pendant la parabiose. *Compt. rend. Soc. biol.*, **102**, 280-282.
- KALLAS, H. 1930. Zur Frage nach der innersekretorischen Tätigkeit des infantilen Eierstockes. *Klin. Wehnschr.*, **9**, 1345-1346.
- KAMELL, S. A., AND ATKINSON, W. B. 1948. Absence of prolongation of pseudopregnancy by induction of deciduomata in the mouse. *Proc. Soc. Exper. Biol. & Med.*, **67**, 415-416.
- KAMMLADE, W. G., JR., WELCH, J. A., NALBANDOV, A. V., AND NORTON, H. W. 1952. Pituitary activity of sheep in relation to the breeding season. *J. Anim. Sc.*, **11**, 646-655.
- KEMPF, R. 1950. Contribution à l'étude du mécanisme de libération des hormones gonadotropes hypophysaire chez le rat. *Arch. biol.*, **61**, 501-594.
- KIRKPATRICK, C. M., AND LEOPOLD, A. C. 1952. The role of darkness in sexual activity in the quail. *Science*, **116**, 280-281.
- KLEIN, M. 1947. Oestrogen level and ovarian hypophysial relationship during pseudopregnancy and pregnancy in the rabbit. *J. Endocrinol.*, **5**, xxv-xxvii.
- KLEIN, M., AND MAYER, G. 1943. Cited from Mayer, 1951.
- KLEIN, M., AND MAYER, G. 1946. Production d'une nouvelle phase lutéinique au cours de la gestation chez la lapin. *Compt. rend. Soc. biol.*, **140**, 600-602.
- KOIKEGAMI, H., YAMADA, T., AND USEI, K. 1954. Stimulation of the amygdaloid nuclei and periamygdaloid cortex with special reference to its effects on uterine movements and ovulation. *Folia Psychiat. Neurol. Japon.*, **8**, 7-31.
- KOLLAR, E. J. 1953. Reproduction in the female rat after pelvic nerve neurectomy. *Anat. Rec.*, **115**, 641-658.
- KOSTITCH, A., AND TELÉBAKOVITCH, A. 1929. Sur un rythme vaginal chez les animaux ovariectomisés. *Compt. rend. Soc. biol.*, **100**, 51-54.
- KUROTSU, T., KURACHI, K., AND BAN, T. 1950. Experimental studies on ovulation by the electrical stimulation of the hypothalamus of rabbits. *Med. J. Osaka Univ.*, **2**, 1-12.
- KUROTSU, T., KURACHI, K., TABAYASHI, C., AND BAN, T. 1952. Experimental studies on ovulation by the electrical stimulation of the hypothalamus in hypophysectomized rabbits. *Med. J. Osaka Univ.*, **3**, 139-150.
- LAHR, E. L., AND RIDDELL, O. 1936. Temporary suppression of estrous cycles in the rat by prolactin. *Proc. Soc. Exper. Biol. & Med.*, **34**, 880-883.
- LANDSMEER, J. M. F. 1951. Vessels of the rat's hypophysis. *Acta Anat.*, **12**, 84-109.
- LANE, C. E. 1935. Some influences of oestrin on the hypophyseal-gonad complex of the immature female rat. *Am. J. Physiol.*, **110**, 681-685.
- LANE, C. E., AND DAVIS, R. F. 1939. The ovary of the adult rat. I. Changes in growth of the follicle and in volume and mitotic activity of the granulosa and theca during the estrous cycle. *Anat. Rec.*, **73**, 429-442.
- LANE, C. E., AND GREER, R. O. 1935. The follicular apparatus of the ovary of the hypophysectomized immature rat and the effects of hypophyseal gonadotropic hormones on it. *Anat. Rec.*, **63**, 139-146.
- LAQUEUR, G. L., AND FLUHMAN, C. F. 1942. Effects of testosterone propionate in immature and adult female rats. *Endocrinology*, **30**, 93-101.
- LEVIN, L., AND TYNDALE, H. H. 1937. Quantitative assay of "follicle stimulating" substances. *Endocrinology*, **21**, 619-628.
- LEVINE, W. T., AND WITSCHI, E. 1933. Endocrine reactions in female rats after X-ray treatment of the ovaries. *Proc. Soc. Exper. Biol. & Med.*, **30**, 1152-1153.
- LICHE, H. 1939. Oestrous cycle in the cat. *Nature*, London, **143**, 900.
- LIPSCHUTZ, A., IGLESIAS, R., BRUZZONE, S., HUMERIZ, J., AND PEÑARANDA, J. M. 1948. Progesterone and desoxycorticosterone in the steroid control of the gonadotrophic function of the hypophysis. *Endocrinology*, **42**, 201-209.
- LOEB, L. 1911. Über die Bedeutung des Corpus luteum für die Periodizität des sexuellen Zyklus beim weiblichen Säugetierorganismus. *Deutsche med. Wehnschr.*, **37**, 17-21.
- LOEB, L. 1927. Effects of hysterectomy on the system of sex organs and on periodicity of the sexual cycle in the guinea pig. *Am. J. Physiol.*, **83**, 202-224.

- LONG, J. V., and EVANS, H. M. 1922. The oestrous cycle of the rat and its associated phenomena. Mem. Univ. California, **6**, 1-148.
- LOPEZ COLOMBO DE ALLENDE, I. 1956. Anovulatory cycles in women. *Am. J. Anat.*, **98**, 293-305.
- LYON, R. A. 1956. Prolongation of human corpus luteum life span. *J. Clin. Endocrinol.*, **16**, 922.
- MAKEPEACE, A. W. 1938. Failure of atropine to prevent ovulation following coitus in the rabbit. *Endocrinology*, **23**, 241-242.
- MAKEPEACE, A. W., WEINSTEIN, G. L., and FRIEDMAN, M. H. 1937. The effect of progesterin and progesterone on ovulation in the rabbit. *Am. J. Physiol.*, **119**, 512-516.
- MANDEL, J. 1935. Experimental study of ovarian irradiation and transplantation in the rat. *Anat. Rec.*, **61**, 295-309.
- MANDEL, A. M. 1951. Cyclical changes in the vaginal smear of adult ovariectomized rats. *J. Exper. Biol.*, **28**, 585-592.
- MANDEL, A. M., and ZUCKERMAN, S. 1952. Cyclical changes in the number of medium and large follicles in the adult rat ovary. *J. Endocrinol.*, **8**, 341-346.
- MARDEN, W. G. R. 1952. The hormone control of ovulation in the calf. *Endocrinology*, **50**, 456-461.
- MARONES, E., BRUZZONE, S., IGLESIAS, R., and LIPSCHUTZ, A. 1951. The non-concomitancy of the progestational and antiluteinizing actions of steroids. *Endocrinology*, **49**, 817-825.
- MARION, G. B., SMITH, V. R., WILEY, T. E., and BARRETT, G. R. 1950. The effect of sterile copulation on time of ovulation in dairy heifers. *J. Dairy Sci.*, **33**, 885-889.
- MARKEE, J. E. 1948. Morphological basis for menstrual bleeding. *Bull. New York Acad. Med.*, **24**, 253-268.
- MARKEE, J. E., and BERG, B. 1944. Cyclic fluctuations in blood estrogen as a possible cause of menstruation. *Stanford Med. Bull.*, **2**, 55-60.
- MARKEE, J. E., SAWYER, C. H., and HOLLINSHEAD, W. H. 1946. Activation of the anterior hypophysis by electrical stimulation in the rabbit. *Endocrinology*, **38**, 345-357.
- MARKEE, J. E., SAWYER, C. H., and HOLLINSHEAD, W. H. 1948. Adrenergic control of the release of luteinizing hormone from the hypophysis of the rabbit. *Recent Progr. Hormone Res.*, **2**, 117-131.
- MARKEE, J. E., FAYRETT, J. W., and SAWYER, C. H. 1952. The relationship of the nervous system to the release of gonadotrophin and the regulation of the sex cycle. *Recent Progr. Hormone Res.*, **7**, 139-163.
- MARSHALL, F. H. A. 1942. Exteroceptive factors in sexual periodicity. *Biol. Rev.*, **17**, 68-90.
- MARSHALL, F. H. A., and VERNEY, E. B. 1936. The occurrence of ovulation and pseudopregnancy in the rabbit, as a result of central nervous stimulation. *J. Physiol.*, **86**, 327-336.
- MARTINEZ-ESTIARTE, P. 1937. Le cycle sexual vaginal chez le marsupial *Didelphys azarac*. *Compt. rend. Soc. Biol.*, **124**, 502-504.
- MARVIN, H. N. 1947. Diestrus and the formation of corpora lutea in rats with persistent estrus, treated with desoxycorticosterone acetate. *Anat. Rec.*, **98**, 383-392.
- MARVIN, H. N., and MEYER, R. K. 1941. Diestrus and corpus luteum formation in persistent-estrous rats by luteinizing hormone and antigonadotrophic serum. *Endocrinology*, **29**, 965-968.
- MATTHEWS, L. H. 1939. Visual stimulation and ovulation in pigeons. *Proc. Roy. Soc., London, ser. B*, **126**, 557-560.
- MAY, R. M. 1937. La greffe brétoplastique de l'hypophyse chez le rat. LXX Congress Soc. savantes, pp. 241-248.
- MAYER, G. 1951. La prolactine, facteur lutéotrophique. *Arch. sc. physiol.*, **5**, 247-275.
- MAZER, C., ISRAEL, S. L., and ALPERS, B. J. 1936. The time element in the pituitary-ovarian response to large doses of the estrogenic hormone. *Endocrinology*, **20**, 753-761.
- McCANN, S. M., MACK, R., and GALE, C. 1958. Neural control of lactation. *Fed. Proc.*, **17**, 107.
- McCONNELL, E. M. 1953. The arterial blood supply of the human hypophysis cerebri. *Anat. Rec.*, **115**, 175-201.
- McKENZIE, F. F., and TERRILL, C. E. 1936. Estrus, ovulation, and the related phenomena in the ewe. *Univ. Missouri Agric. Exper. Sta. Res. Bull.*, **264**, 1-88.
- McKEOWN, T., and ZUCKERMAN, S. 1937. Stimulation of the corpora lutea of the rat by means of progesterone and testosterone. *Proc. Roy. Soc. London, ser. B*, **124**, 362-368.
- MERCKEL, C., and NELSON, W. O. 1910. The relation of the estrogenic hormone to the formation and maintenance of corpora lutea in mature and immature rats. *Anat. Rec.*, **76**, 391-409.
- MEYER, R. K., LEONARD, S. L., and HISAW, F. L. 1929. Effect of anesthesia on artificial production of pseudopregnancy in the rat. *Proc. Soc. Exper. Biol. & Med.*, **27**, 340-342.
- MEYER, R. K., PRASAD, M. R. N., and COCHRANE, R. L. 1958. Delayed implantation in the rat induced by autografts of the hypophysis. *Anat. Rec.*, **130**, 339.
- MIEGEL, B. 1952. Die Biologie und Morphologie der Fortpflanzung der Bismuratte (*Onclatra zibethica* L.). *Ztschr. mikroskop.-anat. Forsch.*, **58**, 531-598.
- MOON, H. D., and LI, C. H. 1952. Effect of follicle-stimulating hormone on gonads of immature C57 black mice. *Proc. Soc. Exper. Biol. & Med.*, **79**, 505-507.
- MOORE, C. R., and PRICE, D. 1932. Gonad hormone functions and the reciprocal influence between gonads and hypophysis, with its bearing on sex hormone antagonism. *Am. J. Anat.*, **50**, 13-71.
- MOORE, C. R., SIMMONS, G. F., WELLS, L. J., ZA-

- LESKY, M., AND NELSON, W. O. 1934. On the control of reproductive activity in an annual-breeding mammal (*Citellus tridecemlineatus*). *Anat. Rec.*, **60**, 279-289.
- MOORE, W. W., AND NALBANDOV, A. V. 1953. Neutrogenic effects of uterine distention on the oestrous cycle of the ewe. *Endocrinology*, **53**, 1-11.
- MOORE, W. W., AND NALBANDOV, A. V. 1955. Maintenance of corpora lutea in sheep with lactogenic hormone. *J. Endocrinol.* **13**, 18-25.
- MOSSMAN, H. W. 1937. The thecal gland and its relation to the reproductive cycle; a study of the cyclic changes in the ovary of the pocket gopher, *Geomys bursarius* (Shaw). *Am. J. Anat.*, **61**, 289-319.
- MÜLLER, O., AND BOOT, L. M. 1959. Induction of mammary cancer in mice without the mammary tumor agent by isografts of hypophyses. *Cancer Res.*, **19**, 402-412.
- MYERS, H. I., YOUNG, W. C., AND DEMPSEY, E. W. 1936. Graafian follicle development throughout the reproductive cycle in the guinea pig, with especial reference to changes during oestrus (sexual receptivity). *Anat. Rec.*, **65**, 381-401.
- NATHANSON, I. T., FRANSEEN, C. C., AND SWEENEY, A. R., JR. 1938. Nature of the action of testosterone on genital tract of the immature female rat. *Proc. Soc. Exper. Biol. & Med.*, **39**, 385-388.
- NAVORI, C. A., FUGO, N. W., AND DAVES, M. E. 1952. Effect of tubal ligation on ovarian function in the rat. *Proc. Soc. Exper. Biol. & Med.*, **81**, 649-652.
- NELSON, W. O. 1946. Factors concerned in the maintenance of function of the corpus luteum. *J. Clin. Endocrinol.*, **6**, 465-466.
- NELSON, W. O., AND PICHETTE, J. W. 1943. Maintenance of corpora lutea in hypophysectomized rats by lactogenic hormone. *Fed. Proc.*, **2**, 36.
- NIKITOVITCH-WINER, M. 1957. Hormonal influence of the hypothalamus on gonadotrophin secretions. Dissertation, Duke University.
- NIKITOVITCH-WINER, M., AND EVERETT, J. W. 1957. Resumption of gonadotrophic function in pituitary grafts following re-transplantation from kidney to median eminence. *Nature, London*, **180**, 1434-1435.
- NIKITOVITCH-WINER, M., AND EVERETT, J. W. 1958a. Comparative study of luteotropin secretion by hypophysial autotransplants in the rat. Effects of site and stages of the estrus cycle. *Endocrinology*, **62**, 522-532.
- NIKITOVITCH-WINER, M., AND EVERETT, J. W. 1958b. Functional restitution of pituitary grafts re-transplanted from kidney to median eminence. *Endocrinology*, **63**, 916-930.
- NIKITOVITCH-WINER, M., AND EVERETT, J. W. 1959. Histo cytologic changes in grafts of rat pituitary on the kidney and upon re-transplantation under the dienecephalon. *Endocrinology*, **65**, 357-368.
- NISSIM, J. A., AND ROBSON, J. M. 1952. The conversion of pregnenolone to a more active gestational substance by incubation with endocrine tissues *in vitro*. *J. Endocrinol.*, **8**, 329-335.
- NOWAKOWSKI, H. 1950. Zur Auslösung der Ovulation durch elektrische Reizung des Hypothalamus beim Kaninchen und ihre Beeinflussung durch Rückenmarksdurchschneidung. *Acta neuroveg.*, **1**, 13-39.
- NOWAKOWSKI, H. 1952. Gomori-positive and Gomori-negative nerve fibers in the neurohypophysis and their physiological significance. *Ciba Foundation Colloquia Endocrinol.*, **4**, 65-71.
- PARKES, A. S. 1926a. On the occurrence of the oestrous cycle after X-ray sterilization. III. Periodicity of oestrus after sterilization of the adult. *Proc. Roy. Soc., London, ser. B*, **101**, 421-449.
- PARKES, A. S. 1926b. On the occurrence of the oestrous cycle after X-ray sterilization. IV. Irradiation of the adult during pregnancy and lactation; and general summary. *Proc. Roy. Soc., London, ser. B*, **102**, 51-62.
- PARKES, A. S. 1949. Obituary, F. H. A. Marshall. *J. Endocrinol.*, **6**, 1-5.
- PARKES, A. S. 1950. Androgenic activity of the ovary. *Recent Progr. Hormone Res.*, **5**, 101-114.
- PARKES, A. S. 1952. Ovarian periodicity in the absence of cyclic structures. *Ciba Foundation Colloquia Endocrinol.*, **4**, 264-267.
- PEARSON, O. P. 1944. Reproduction in the shrew (*Blarina brevicauda*, Say). *Am. J. Anat.*, **75**, 39-93.
- PEARSON, O. P., AND ENDERS, R. K. 1944. Duration of pregnancy in certain Mustelids. *J. Exper. Zool.*, **95**, 21-35.
- PEDERSEN-BJERGAARD, G., AND PEDERSEN-BJERGAARD, K. 1948. Sex hormone analysis. III. Estrogenic and gonadotropic substances in the urine from a woman with normal menstrual cycles and normal pregnancies. *Acta endocrinol.*, **1**, 263-281.
- PENCHARZ, R. I. 1940. Effect of estrogens and androgens alone and in combination with chorionic gonadotropin on the ovary of the hypophysectomized rat. *Science*, **91**, 554-555.
- PFEIFFER, C. A. 1926. Sexual differences of the hypophyses and their determination by the gonads. *Am. J. Anat.*, **58**, 195-225.
- PFEIFFER, C. A. 1937. Hypophysial gonadotropic hormones and the luteinization phenomenon in the rat. *Anat. Rec.*, **67**, 159-175.
- PFEIFFER, C. A. 1941. Hormone factors in the formation and maintenance of corpora lutea in "constant" oestrous rats. *Anat. Rec.*, **79**, (No. 3, Suppl.), 50.
- PFEIFFER, C. A. 1950. Effects of progesterone on ovulation in Rhesus monkeys. *Anat. Rec.*, **106**, 233.
- PFEIFFER, C. A., AND HOOKER, C. W. 1942. Experiments on the source of ovarian androgen in the mouse. *Anat. Rec.*, **83**, 543-571.
- PHELPS, D., ELLISON, E. T., AND BURCH, J. C.

- SHU, QAO. Structure and function of pituitary glands in untreated rats, and in rats injected with estrogen. *Endocrinology*, **25**, 227-236.
- SHOGLISS, W. A. 1937. The inhibition of estrous cycles in the albino rat by progesterone. *Am. J. Physiol.*, **119**, 623-626.
- PINCUS, G. 1948. *The Hormones*, Vol. 1. New York: Academic Press, Inc.
- PINCUS, G., AND ENZMANN, E. V. 1935. Comparative behavior of mammalian eggs *in vivo* and *in vitro*. *J. Exper. Med.*, **62**, 665-675.
- PORTER, R. W., CAVANAUGH, E. B., AND SAWYER, C. H. 1954. Alterations in hypothalamic activity of estrous cats following vaginal stimulation. *Anat. Rec.*, **120**, 775.
- PRICE, D., AND ORTIZ, E. 1944. The relation of age to reactivity in the reproductive system of the rat. *Endocrinology*, **34**, 215-239.
- RAKOFF, A. E., AND CANTAROW, A. 1950. Estrogen content of blood of ovarian vein of the dog and spermatic vein of the stallion. *Fed. Proc.*, **9**, 103.
- RASMUSSEN, A. T. 1938. Innervation of the hypophysis. *Endocrinology*, **23**, 263-278.
- RISMAN, G. C. 1946. Experimental stimulation of the female reproductive tract in the opossum (*Didelphys virginiana*). *Anat. Rec.*, **94**, 408.
- ROBINSON, T. J. 1951. Reproduction in the ewe. *Biol. Rev.*, **26**, 121-157.
- ROBSON, J. M. 1937. Maintenance by estrin of the luteal function in hypophysectomized rabbits. *J. Physiol.*, **90**, 435-439.
- ROBSON, J. M. 1938. The rôle of gonadotrophic hormone in the maintenance of luteal function. *Quart. J. Exper. Physiol.*, **28**, 49-59.
- ROBSON, J. M. 1947. *Recent Advances in Sex and Reproductive Physiology*. Philadelphia: Blakiston Company.
- ROSSMAN, I., AND BARTELMIZ, G. W. 1946. Delayed ovulation, a significant factor in the variability of the menstrual cycle. *Am. J. Obst. & Gynec.*, **52**, 28-33.
- ROTHCHILD, I., MEYER, R. K., AND SPIELMAN, M. A. 1940. A quantitative study of oestrogen-progesterone interaction in the formation of placentalomata in the castrate rat. *Am. J. Physiol.*, **128**, 213-221.
- ROTHCHILD, I., AND FRAHS, R. M. 1949. The induction of ovulating hormone release from the pituitary of the domestic hen by means of progesterone. *Endocrinology*, **44**, 141-149.
- ROTHCHILD, I., AND KOH, N. K. 1951. The effects of a single preovulatory injection of progesterone on indices of ovulation in women. *J. Clin. Endocrinol.*, **11**, 789.
- SALMON, U. J. 1938. The effect of testosterone propionate on the genital tract of the immature female rat. *Endocrinology*, **23**, 779-783.
- SANDERS, A., AND RENNELS, E. G. 1957. The cytology and functional capacity of the rat pituitary gland after autotransplantation. *Anat. Rec.*, **127**, 360.
- SAWYER, C. H. 1949. Reflex induction of ovulation in the estrogen-treated rabbit by artificial vaginal stimulation. *Anat. Rec.*, **103**, 502.
- SAWYER, C. H. 1952. Progesterone initially facilitates and later inhibits release of pituitary ovulating hormone in the rabbit. *Fed. Proc.*, **11**, 138.
- SAWYER, C. H. 1955. Rhinencephalic involvement in pituitary activation by intraventricular histamine in the rabbit under Nembutal anesthesia. *Am. J. Physiol.*, **180**, 37-46.
- SAWYER, C. H. 1958. Activation and blockade of the release of pituitary gonadotropin as influenced by the reticular formation. In *Reticular Formation of the Brain* (Henry Ford Hospital Symposium). Boston: Little, Brown & Company.
- SAWYER, C. H. 1959. Seasonal variation in the incidence of spontaneous ovulation in rabbits following estrogen treatment. *Endocrinology*, **65**, 523-525.
- SAWYER, C. H., MARKEE, J. E., AND HOLLINSHEAD, W. H. 1947. Inhibition of ovulation in the rabbit by the adrenergic-blocking agent Dibenzamine. *Endocrinology*, **41**, 395-402.
- SAWYER, C. H., EVERETT, J. W., AND MARKEE, J. E. 1949. A neural factor in the mechanism by which estrogen induces the release of luteinizing hormone in the rat. *Endocrinology*, **44**, 218-233.
- SAWYER, C. H., MARKEE, J. E., AND TOWNSEND, B. F. 1949. Cholinergic and adrenergic components in the neurohumoral control of the release of LH in the rabbit. *Endocrinology*, **44**, 18-37.
- SAWYER, C. H., EVERETT, J. W., AND MARKEE, J. E. 1950. "Spontaneous" ovulation in the rabbit following combined estrogen-progesterone treatment. *Proc. Soc. Exper. Biol. & Med.*, **74**, 185-186.
- SAWYER, C. H., MARKEE, J. E., AND EVERETT, J. W. 1950a. Further experiments on blocking pituitary activation in the rabbit and the rat. *J. Exper. Zool.*, **113**, 659-682.
- SAWYER, C. H., MARKEE, J. E., AND EVERETT, J. W. 1950b. Activation of the rabbit adenohypophysis by intravenous injections of epinephrine in the atropinized rabbit. *Endocrinology*, **46**, 536-543.
- SAWYER, C. H., MARKEE, J. E., AND EVERETT, J. W. 1951a. Failure of nerve-blocking agents to prevent the effects of placental gonadotrophins in the rabbit. *Endocrinology*, **49**, 162-167.
- SAWYER, C. H., MARKEE, J. E., AND EVERETT, J. W. 1951b. Blockade of neurogenic stimulation of the rabbit adenohypophysis by Banthine. *Am. J. Physiol.*, **166**, 223-228.
- SAWYER, C. H., AND EVERETT, J. W. 1953. Priming the anestrous cat for reflex discharge of pituitary ovulating hormone. *Proc. Soc. Exper. Biol. & Med.*, **83**, 820-821.
- SAWYER, C. H., AND PARKERSON, G. R., JR. 1953. Mechanisms of partial blockade of the stress response in rats by Dibenzamine analogues. *Endocrinology*, **52**, 346-356.
- SAWYER, C. H., CRITCHLOW, B. V., AND BARRACLOUGH, C. A. 1955. Mechanism of blockade

- of pituitary activation in the rat by morphine, atropine and barbiturates. *Endocrinology*, **57**, 345-354.
- SCHMIDT, I. G. 1936. The excretion of theelin in the urine of guinea pigs with irradiated ovaries. *Anat. Rec.*, **64**, 255-266.
- SCHMIDT, I. G. 1942. Mitotic proliferation in the ovary of the normal mature guinea pig treated with colchicine. *Am. J. Anat.*, **71**, 245-270.
- SCHULTZ, A. H., AND SNYDER, F. F. 1935. Observations on reproduction in the chimpanzee. *Bull. Johns Hopkins Hosp.*, **57**, 193-205.
- SCHWEIZER, M., CHARIPPER, H. A., AND HATERIUS, H. O. 1937. Experimental studies of the anterior pituitary. IV. The replacement capacity and the non-cyclic behavior of homoplastic anterior pituitary grafts. *Endocrinology*, **21**, 30-39.
- SCHWEIZER, M. H., CHARIPPER, H. A., AND KLEINBERG, W. 1940. Experimental studies of the anterior pituitary. *Endocrinology*, **26**, 979-986.
- SELYE, H. 1939. The effect of progesterone on the mouse ovary as influenced by gestation. *Anat. Rec.*, **75**, 59-73.
- SELYE, H. 1940. Production of persistent changes in the genital organs of immature female rats treated with testosterone. *Endocrinology*, **27**, 657-660.
- SELYE, H., AND McKEOWN, T. 1934. Studies on pseudopregnancy. *Am. J. Physiol.*, **109**, 96.
- SELYE, H., COLLIP, J. B., AND THOMSON, D. L. 1935. Effect of oestrin on ovaries and adrenals. *Proc. Soc. Exper. Biol. & Med.*, **32**, 1377-1381.
- SELYE, H., BROWNE, J. S. L., AND COLLIP, J. B. 1936. Effects of large doses of progesterone in the female rat. *Proc. Soc. Exper. Biol. and Med.*, **34**, 472-474.
- SHEALY, C. N., AND PEELE, T. L. 1957. Studies on the amygdaloid nucleus of the cat. *J. Neurophysiol.*, **20**, 125-139.
- SIELESNYAK, M. C. 1931. Induction of pseudopregnancy in the rat by means of electrical stimulation. *Anat. Rec.*, **49**, 179-183.
- SHIBUSAWA, K., SAITO, S., FUKUDA, M., KAWAI, T., YAMADA, H., AND TOMIZAWA, K. 1955. Neurosecretion of oxytocin stimulates the release of the pituitary gonadotrophin. *Endocrinol. Japon.*, **2**, 183-188.
- SIMPSON, M. E., EVANS, H. M., FRAENKEL-CONRAT, H. L., AND LI, C. H. 1941. Synergism of estrogens with pituitary gonadotropins in hypophysectomized rats. *Endocrinology*, **28**, 37-41.
- SIMPSON, M. E., AND VAN WAGENEN, G. 1953. Response of the ovary of the monkey (*Macaca mulatta*) to the administration of pituitary follicle stimulating hormone (FSH). *Anat. Rec.*, **115**, 370.
- SMITH, O. W. 1944. The pituitary responses of mature male rats to an oxidation inactivation product of estrone. *Endocrinology*, **35**, 146-157.
- SMITH, O. W., SMITH, G. VANS, AND SCHILLER, S. 1943. Clinical experiments in relation to the excretion of the estrogens. III. Urinary estrogens in a normal menstrual cycle and in a case of essential dysmenorrhea. *Am. J. Obst. & Gynec.*, **45**, 15-22.
- SMITH, P. E. 1939. The effect on the gonads of the ablation and implantation of the hypophysis and the potency of the hypophysis under various conditions. In *Sex and Internal Secretions*, 2nd ed., E. Allen, C. H. Danforth, and E. A. Doisy, Eds., Ch. XVI. Baltimore: The Williams & Wilkins Company.
- SMITH, P. E., AND ENGLE, E. T. 1927. Experimental evidence regarding the rôle of the anterior pituitary in the development and regulation of the genital system. *Am. J. Anat.*, **40**, 159-217.
- SMITH, P. E., AND WHITE, W. E. 1931. The effect of hypophysectomy on ovulation and corpus luteum formation in the rabbit. *J. A. M. A.*, **97**, 1861-1863.
- SPATZ, H. 1951. Neues über die Verknüpfung von Hypophyse und Hypothalamus. Mit besonderer Berücksichtigung der Regulation sexueller Leistungen. *Acta neuroveg.*, **3**, 5-49.
- STAFFORD, W. T., COLLINS, R. F., AND MOSSMAN, H. W. 1942. The thecal gland in the guinea pig ovary. *Anat. Rec.*, **83**, 193-203.
- STURGIS, S. H. 1949. Rate and significance of atresia of the ovarian follicle of the rhesus monkey. *Contr. Embryol.*, Carnegie Inst. Washington, **33**, 67-80.
- STURGIS, S. H., AND MEIGS, J. V. 1942. The use of estradiol dipropionate in the treatment of essential dysmenorrhea. *Surg. Gynec. & Obst.*, **75**, 87-92.
- SULMAN, F., AND BLACK, R. 1945. The alleged endocrine effect of yohimbine. *Endocrinology*, **36**, 70-71.
- SWINGLE, W. W., SEAY, P., PERLAUTT, J., COLLINS, E. J., FEDOR, E. J., AND BARLOW, G., JR. 1951. Effect of electrical stimulation of uterine cervix upon sexual development of prepubertal rats. *Am. J. Physiol.*, **167**, 599-604.
- TAKASUGI, N. 1954. Einflüsse von Androgen und Progesteron auf die Ovarien der Ratten, denen sofort nach der Geburt Oestrogeninjektion durchgeführt wurde. *J. Fac. Sc. Univ. Tokyo*, sec. IV, **7**, 299-311.
- TALBERT, G. B., MEYER, R. K., AND McSHAN, W. H. 1951. Effect of hypophysectomy at the beginning of proestrus on maturing follicles in the ovary of the rat. *Endocrinology*, **49**, 687-694.
- TAUBENHAUS, M., AND SOSKIN, S. 1941. Release of luteinizing hormone from the anterior hypophysis by an acetylcholine-like substance from the hypothalamic region. *Endocrinology*, **29**, 958-964.
- THOMPSON, A. D. P., AND ZUCKERMAN, S. 1954. The effect of pituitary-stalk section on light-induced oestrus in ferrets. *Proc. Roy. Soc. London*, ser. B, **142**, 437-451.
- TOBIN, C. E. 1942. Effects of lactogen on normal and adrenalectomized rats. *Endocrinology*, **31**, 197-200.
- ULBERG, L. C., CHRISTIAN, R. E., AND CASIDA, L. F.

1951. Ovarian response in heifers to progesterone injections. *J. Anim. Sc.*, **10**, 752-759.
- VAN DYKE, H. B., AND LI, R. C. 1938. The secretion of progesterone by the cat's ovary following the formation of corpora lutea due to the injection of anterior pituitary extract or prolactin. *Chinese J. Physiol.*, **13**, 213-228.
- VAN TIENHOVEN, A. 1953. Further study on the neurogenic blockage of LH release in the hen. *Anat. Rec.*, **115**, 374-375.
- VAN TIENHOVEN, A. 1955. The duration of stimulation of the fowl's anterior pituitary for progesterone-induced LH release. *Endocrinology*, **56**, 667-674.
- VAN TIENHOVEN, A., NALBANDOV, A. V., AND NORTON, H. W. 1954. Effect of Dibenzamine on progesterone-induced and "spontaneous" ovulation in the hen. *Endocrinology*, **54**, 605-611.
- VAN WAGENEN, G., AND SIMPSON, M. E. 1957. Induction of multiple ovulation in the rhesus monkey (*Macaca mulatta*). *Endocrinology*, **61**, 316-318.
- VELARDO, J. T., AND HISAW, F. L. 1951. Quantitative inhibition of progesterone by estrogens in development of deciduomata. *Endocrinology*, **49**, 530-537.
- VELARDO, J. T., DAWSON, A. B., OLSEN, A. G., AND HISAW, F. L. 1953. Sequence of histological changes in the uterus and vagina of the rat during prolongation of pseudopregnancy associated with the presence of deciduomata. *Am. J. Anat.*, **93**, 273-305.
- VELARDO, J. T., OLSEN, A. G., HISAW, F. L., AND DAWSON, A. B. 1953. The influence of decidual tissue upon pseudopregnancy. *Endocrinology*, **53**, 216-220.
- VENNING, E. H., AND BROWNE, J. S. L. 1937. Studies on corpus luteum function. I. The urinary excretion of sodium pregnanediol glucuronide in the human menstrual cycle. *Endocrinology*, **21**, 711-721.
- VERLY, W. G. 1951. The urinary excretion of prenae-3 $\alpha$ :20 $\alpha$ -diol in the female rabbit immediately after mating. *J. Endocrinol.*, **7**, 258-259.
- VEZINS, C. D. 1951. Cycle vaginal chez les femmes castrées ou ménopausées. *Ann. endocrinol.*, **12**, 917-921.
- VOGT, M. 1931. Über den Mechanismus der Auslösung der Gravidität und Pseudogravidität zugleich ein physiologischer Beweis für die sympathische Innervation des Hypophysenvorderlappens. *Arch. exper. Path. Pharmacol.*, **162**, 197-208.
- VOGT, M. 1933. Über den Mechanismus der Auslösung der Gravidität. II. Mitteilung. *Arch. exper. Path. Pharmacol.*, **170**, 72-83.
- WALTON, A., AND HAMMOND, J. 1928. Observations on ovulation in the rabbit. *Brit. J. Exper. Biol.*, **6**, 190-201.
- WARWICK, E. J. 1916. Gonadotrophic potency of ewe pituitary glands as affected by spaying, season, and breed. *Proc. Soc. Exper. Biol. & Med.*, **63**, 530-533.
- WATERMAN, A. J. 1943. Studies of normal development of the New Zealand White strain of rabbit. *Am. J. Anat.*, **73**, 473-515.
- WEINBERGER, L. M., AND GRANT, F. C. 1941. Precocious puberty and tumors of the hypothalamus. *Arch. Int. Med.*, **67**, 762-792.
- WEITHESEN, N. T., SCHWENK, E., AND BAKER, C. 1953. Biosynthesis of estrone and  $\beta$ -estradiol in the perfused ovary. *Science*, **117**, 380-381.
- WESTMAN, A. 1934. Untersuchung über die Abhängigkeit der Funktion des Corpus luteum von den Ovarialfollikeln und über die Bildungsstätte der Hormone im Ovarium. *Arch. Gynäk.*, **158**, 476-504.
- WESTMAN, A. 1947. The effect of Prominal on the sexual cycle. *Acta med. scandinav.*, **128**, Suppl. 196, 111-115.
- WESTMAN, A., AND JACOBSSON, D. 1936. Über Ovarialveränderungen beim Kaninchen nach Hypophysektomie. *Acta obst. gynec. scandinav.*, **16**, 483-508.
- WESTMAN, A., AND JACOBSSON, D. 1937a. Über Oestrinwirkung auf die Corpus luteum-Funktion. I. *Acta obst. gynec. scandinav.*, **17**, 1-12.
- WESTMAN, A., AND JACOBSSON, D. 1937b. Über Oestrinwirkung auf die Corpus luteum-Funktion. II. *Acta obst. gynec. scandinav.*, **17**, 13-23.
- WESTMAN, A., AND JACOBSSON, D. 1937c. Experimentelle Untersuchungen über die Bedeutung des Hypophysen-Zwischenhirnsystems für die Produktion gonadotroper Hormone des Hypophysenvorderlappens. *Acta obst. gynec. scandinav.*, **17**, 235-265.
- WESTMAN, A., AND JACOBSSON, D. 1938a. Endokrinologische Untersuchungen an Ratten mit durchtrenntem Hypophysenstiel. I. Hypophysenveränderungen nach Kastration und nach Oestrinbehandlungen. *Acta obst. gynec. scandinav.*, **18**, 99-108.
- WESTMAN, A., AND JACOBSSON, D. 1938b. Endokrinologische Untersuchungen an Ratten mit durchtrenntem Hypophysenstiel. III. Über die luteinizierende Wirkung des Follikelhormons. *Acta obst. gynec. scandinav.*, **18**, 115-123.
- WESTMAN, A., AND JACOBSSON, D. 1938c. Endokrinologische Untersuchungen an Ratten mit durchtrenntem Hypophysenstiel. VI. Produktion und Abgabe der gonadotropen Hormone. *Acta path. et microbiol. scandinav.*, **15**, 145-153.
- WESTMAN, A., AND JACOBSSON, D. 1940. Endokrinologische Untersuchungen an Kaninchen mit durchtrenntem Hypophysenstiel. *Acta obst. gynec. scandinav.*, **20**, 392-433.
- WESTMAN, A., AND JACOBSSON, D. 1942. Die Wirkung transorbital an das Tubum cinereum injizierten Novocains auf die Ovulation. *Acta obst. gynec. scandinav.*, **22**, 16-23.
- WHITAKER, W. L. 1910. Some effects of artificial illumination on reproduction in the white-footed mouse, *Peromyscus leucopus noveboracensis*. *J. Exper. Zool.*, **83**, 33-60.
- WILLIAMS, P. C. 1940. Effect of stilboestrol on

- the ovaries of hypophysectomized rats. *Nature*, London, **145**, 388-389.
- WILLIAMS, P. C. 1944. Ovarian stimulation by oestrogens: effects in immature hypophysectomized rats. *Proc. Roy. Soc. London, ser. B*, **132**, 189-199.
- WILLIAMS, P. C. 1945a. Ovarian stimulation by oestrogens. II. Stimulation in the absence of the hypophysis, uterus, and adrenal glands. *J. Endocrinol.*, **4**, 125-126.
- WILLIAMS, P. C. 1945b. Studies of the biological action of serum gonadotrophin. II. Ovarian response after hypophysectomy and oestrogen treatment. *J. Endocrinol.*, **4**, 131-136.
- WILSON, R. B., RANDALL, L. M., AND OSTERBERG, A. E. 1939. Studies on pregnandiol. *Am. J. Obst. & Gynec.*, **37**, 59-74.
- WISLOCKI, G. B., AND KING, L. S. 1936. The permeability of the hypophysis and hypothalamus to vital dyes, with a study of the hypophyseal vascular supply. *Am. J. Anat.*, **58**, 421-472.
- WOLFE, J. M. 1935. Reaction of ovaries of mature female rats to injection of oestrin. *Proc. Soc. Exper. Biol. & Med.*, **32**, 757-759.
- WOLFE, J. M., AND HAMILTON, J. B. 1937. Action of male sex hormone with and without oestrin in the female rat. *Proc. Soc. Exper. Biol. & Med.*, **37**, 189-193.
- WORTHINGTON, W. C., JR. 1955. Some observations on the hypophysial portal system in the living mouse. *Bull. Johns Hopkins Hosp.*, **97**, 343-357.
- XUEREB, G. P., PRICHARD, M. M. L., AND DANIEL, P. M. 1954. The hypophysial portal vessels in man. *Quart. J. Exper. Physiol.*, **39**, 219-230.
- YOUNG, W. C., BOLING, J. L., AND BLANDAUC, R. J. 1941. The vaginal smear picture, sexual receptivity, and time of ovulation in the albino rat. *Anat. Rec.*, **80**, 37-45.
- YOUNG, W. C., AND YERKES, R. M. 1943. Factors influencing the reproductive cycle in the chimpanzee; the period of adolescent sterility and related problems. *Endocrinology*, **33**, 121-151.
- ZARROW, M. X., AND BASTIAN, J. W. 1953. Blockade of ovulation in the hen with adrenolytic and parasympatholytic drugs. *Proc. Soc. Exper. Biol. & Med.*, **84**, 457-459.
- ZONDEK, B., AND ASCHHEIM, S. 1927. Hypophysenvorderlappen und Ovarium. Beziehungen der endokrinen Drüsen zur Ovarialfunktion. *Arch. Gynäk.*, **130**, 1-45.
- ZUCKERMAN, S. 1937. The menstrual cycle of primates. X. The oestron threshold of the uterus of the rhesus monkey. *Proc. Roy. Soc. London, ser. B*, **123**, 441-471.
- ZUCKERMAN, S. 1941. Periodic uterine bleeding in sprayed rhesus monkeys injected daily with a constant threshold dose of oestrone. *J. Endocrinol.*, **2**, 263-267.
- ZUCKERMAN, S. 1952. The influence of environmental changes on the anterior pituitary. *Ciba Foundation Colloquia Endocrinol.*, **4**, 213-228.
- ZUCKERMAN, S., AND FULTON, J. F. 1934. The menstrual cycle of the primates. VII. The sexual skin of the chimpanzee. *J. Anat.*, **69**, 38-46.
- ZWARENSTEIN, H. 1937. Experimental induction of ovulation with progesterone. *Nature*, London, **139**, 112-113.

# 9

## ACTION OF ESTROGEN AND PROGESTERONE ON THE REPRODUCTIVE TRACT OF LOWER PRIMATES

*Frederick L. Hisaw, Ph.D.*

THE BIOLOGICAL LABORATORIES, HARVARD UNIVERSITY, CAMBRIDGE,  
MASSACHUSETTS

*and*

*Frederick L. Hisaw, Jr., Ph.D.*

DEPARTMENT OF ZOOLOGY, OREGON STATE COLLEGE, CORVALLIS,  
OREGON

---

I. INTRODUCTION.....	556
II. OVARIAN HORMONES AND GROWTH OF THE GENITAL TRACT.....	558
III. EFFECTS OF PROGESTERONE ON THE UTERUS.....	565
IV. SYNERGISM BETWEEN ESTROGEN AND PROGESTERONE.....	567
V. EXPERIMENTALLY PRODUCED IMPLAN- TATION REACTIONS.....	571
VI. THE CERVIX UTERI.....	572
VII. THE VAGINA.....	575
VIII. SEXUAL SKIN.....	576
IX. MENSTRUATION.....	578
X. THE MECHANISM OF MENSTRUATION.....	583
XI. REFERENCES.....	586

### I. Introduction

Cyclic menstruation is the most characteristic feature of primate reproduction, and distinguishes it from the estrous cycle of lower mammals. This cardinal primate event is heralded by the bloody uterine effluent emanating from the vagina, whereas in estrus the dominant characteristic is a sudden modification in behavior featuring an intense mating drive. However, the internal secretions that regulate the various events in the menstrual and estrous cycles are the same, and this similarity is fundamentally more significant than the key descriptive differences just mentioned. Estrus comes at the peak of the growth phase of the cycle and is associated with ovulation. In

contrast, menstruation occurs in the cycle midway between times of ovulation and is not accompanied by an increase in sexual activity. From earliest times menstruation has been recognized as degenerative: the characteristic odor, and the necrotic changes in the lining of the uterus, part of which is cast off at this time, sustain this interpretation. Therefore, menstruation is at the opposite phase of the cycle from estrus. It is such an obvious event that menstrual cycles are dated from the onset of bleeding. Menstruation is not analogous to the pro-estrous bleeding in the dog or cow nor to the slight bleeding of primates at midpoint between menstrual periods (Hartman, 1929).

The study of menstruation was at first almost entirely the province of the clinician and the material for investigation limited to women. Hitschmann and Adler (1907), Meyer (1911), Schröder (1914), Novak and Te Linde (1924), and Bartelmez (1933) are among many of the earlier investigators who contributed descriptions of the cyclic changes in the human endometrium. The physiology of the menstrual cycle and attendant morphologic changes have continued to be an area of active research interest in science and medicine. Among the many more recent contributors are Bartelmez



(1937), Latz and Reiner (1942), Haman (1942), Knaus (1950), Mazer and Israel (1951), and Crossen (1953).

The earlier concepts regarding the menstrual cycle were based primarily on the changes occurring in the human endometrium and for convenience of description the cycle was divided into four stages or periods. The first of these was the period of active menstruation, and the length of the cycle was dated from its onset. Most authors agreed that menses began by leaking of blood from superficial vessels to form lakes under the surface epithelium and that there was some sloughing of tissue after the beginning of bleeding. There was considerable disagreement as to the amount of destruction and loss of tissue; estimates of various authors ranged from very little to almost complete denudation of the surface. Bartelmez (1933) emphasized both the wide individual variability of the amount of tissue lost and differences in the stage of development of the endometria at the time of menstruation.

The second period immediately following menstruation began with regeneration of the surface epithelium, which started sometimes before menstrual bleeding had ceased and was completed in a very short time. This period included the 5 to 7 days after cessation of menses, during which the endometrium grew in thickness. Frequent mitoses were recognized, especially in the glands which lengthened but remained straight and tubular.

The third ("interval") period, lasting 6 to 10 days, was characterized by a somewhat thickened endometrium, still with straight glands and showing little evidence of secretory activity. At first this was considered a quiescent period as indicated by the term "interval." However, as will be shown later, such a characterization was not justified from the physiologic viewpoint.

The fourth period, called the premenstrual period, included the 10 days or 2 weeks before menstruation. During this phase the glands continued to increase in size and became distended, coiled, or even saeculated. The glandular cells increased in height, and there was evidence of glycogen mobilization and secretion. Next, the epithelium became "frayed out" along the

outer borders, then decreased in height, indicating secretory depletion. Decidual cells appeared in the stroma at this time. The endometrium was much thickened and extremely hyperemic. At the height of this period the endometrium was approximately 5 mm. in thickness, as compared with  $\frac{1}{2}$  mm. toward the end of menses. The term premenstrual was usually applied to this phase but today the term progestational would seem preferable.

During and after these descriptions of the changes in the human endometrium, many attempts were made to locate the time of ovulation in the menstrual cycle. When it was found, as will be discussed later, that ovulation occurred approximately midway between two menses, and was preceded by follicular growth and followed by development of a corpus luteum, it became customary to refer to the two halves of the menstrual cycle as the follicular phase and the luteal phase. One advantage of this descriptive terminology was the emphasis it placed on the homology of the two phases of the menstrual cycle in primates with the follicular and luteal phases of the estrous cycles of lower mammals.

A theory to explain menstruation, widely adopted in 1920, was formulated from this morphologic evidence. The essentials were that menstruation occurs because the lining of the uterus, prepared for implantation of the ovum, degenerates if fertilization of the egg does not occur. This required that ovulation and corpus luteum formation precede the premenstrual changes in the endometrium. Subsequent research disclosed that menstrual cycles frequently occur in which ovulation does not take place and bleeding results from the breakdown of an "interval" rather than a progestational endometrium.

The discovery of anovulatory cycles not only brought about a revision of ideas regarding an explanation for menstruation but also raised questions as to what constituted a normal menstrual cycle. The length of the cycle and the amount and duration of bleeding are approximately the same regardless of whether or not ovulation has taken place. The gross features of menstruation under these two conditions are indistinguishable one from the other. However, the biologic purpose of the menstrual cycle

is reproduction which obviously cannot be fulfilled unless an ovum is made available for fertilization. Therefore, in this sense it seems quite clear that anovulatory cycles should be considered incomplete and abnormal.

The investigation of changes taking place in the uterine endometrium at various periods of the menstrual cycle in women was confronted with many difficulties, the chief one being that of obtaining normal tissue representative of specific times of the cycle. The entire uterus and both ovaries are essential for proper evaluations and it was rarely possible to meet these requirements. The material for such studies came from autopsies and surgery and tissues usually had suffered postmortem changes or the surgical condition was one involving serious pelvic disease. There have been, however, a goodly number of instances in which these difficulties were adequately overcome (Stieve, 1926, 1942, 1943, 1944; Allen, Pratt, Newell and Bland, 1930) and the clinic will continue to make important contributions (Rock and Hertig, 1942; Hertig and Rock, 1944), but quite early the need became obvious for a suitable primate that could be used as an experimental animal for research on the different aspects of the physiology of reproduction.

Since the initial observations by Corner (1923) on the menstrual cycles of captive rhesus monkeys (*Macaca mulatta*), more has been learned about the physiology of reproduction of this animal than any other primate. Monkeys of this species thrive under laboratory conditions, which has made it possible to devise accurately controlled experiments on normal healthy animals and obtain reliable information on the menstrual cycle, gestation, fetal development, and the interaction of hormones concerned with regulating reproductive processes.

Other features that make the rhesus monkey such an attractive animal for these purposes are the many morphologic and physiologic attributes that are strikingly like those of the human being. The modal length of their menstrual cycles is 28 days but there is wide variation (Corner, 1923; Hartman, 1932; Zuckerman, 1937a). From an analysis of 1000 cycles recorded for some 80 females of different ages, Zuckerman

(1937a) found an average cycle length of  $33.5 \pm 0.6$  days, and the mode 28 days with an over-all range of 9 to 200 days. Ovulation occurs approximately midway between two menstrual periods, most between the 11th and 14th days (Hartman, 1932, 1944; van Wageningen, 1945, 1947), and although these animals breed at all seasons of the year many cycles are anovulatory, especially during the hot summer months (Eekstein and Zuckerman, 1956). A method developed by Hartman for detecting the exact time of ovulation by palpation of the ovaries in the unanesthetized animal greatly facilitated the timing of events of the menstrual cycle. This procedure also made it possible to determine the age of corpora lutea with great accuracy (Corner, 1942, 1945) and correlate their development and involution with corresponding changes in the endometrium (Bartelmez, 1951) and, in pregnancy, with the exact age of developing embryos (Wislocki and Streeter, 1938; Heuser and Streeter, 1941).

The primary purpose of the present discussion is to review the results of experimental investigations of physiologic processes occurring in the female reproductive tract of lower primates during the menstrual cycle, and particularly those processes that are under hormonal control. The brief introductory presentation of basic observations could be greatly extended and we take up the discussion of endocrine problems knowing that we must return often to the work of these authors and that of others to be cited, as conclusions based on experimental data take on meaning only in terms of normal function.

## II. Ovarian Hormones and Growth of the Genital Tract

The changes that are repeated in different parts of the reproductive tract with each menstrual cycle are produced by ovarian hormones, estrogens, and progesterone. The dominant hormone of the follicular phase is estradiol-17 $\beta$ , which is secreted by the Graafian follicle, and in the tissues is readily transformed in part to estrone, an estrogenic metabolite. Progesterone, secreted by the corpus luteum, is primarily a hormone of the luteal phase of the cycle. However, small amounts of progesterone may appear

in the blood of monkeys as early as the 7th day and attain a concentration of  $1 \mu\text{g}$ . per ml. of serum at ovulation, whereas a maximal concentration of  $10 \mu\text{g}$ . per ml. is reached at approximately the middle of the luteal phase (Forbes, Hooker and Pfeiffer, 1950; Bryans, 1951). Also, some estrogen is present during the luteal phase, probably secreted by the corpus luteum (estrogens can be obtained from luteal tissue) or it may be partially derived from developing follicles. It is unlikely that estrogen is ever entirely absent during a normal menstrual cycle or that the presence of progesterone is completely restricted to the luteal phase.

The dependence of the reproductive tract on ovarian hormones is strikingly demonstrated by the profound atrophy that follows surgical removal of the ovaries. A progressive decrease in size of the Fallopian tubes, uterus, cervix, and vagina takes place, and usually, the involution of the uterine endometrium involves tissue loss and bleeding, commonly referred to as post castration bleeding. Dramatic as these effects may seem, it is equally dramatic to find that these atrophic structures can be restored entirely to their original condition by the administration of ovarian hormones. Therefore, it is seen at the beginning that investigations dealing with the physiology of the female reproductive tract of primates in large measure involve a study of the independent and combined actions of estrogens and progesterone on the activities of the various structures concerned.

Much can be learned about the action of ovarian hormones by observing the changes they produce in the gross appearance of the atrophied reproductive tract of castrated animals. Daily injections of an estrogen in doses equivalent to 1000 I.U. or more for 10 days or a fortnight will restore the uterus, cervix, and vagina to a condition comparable with that found in a normal monkey at the close of the follicular phase of a menstrual cycle (Fig. 9.1A). If a similar castrated monkey is given 1 or 2 mg. of progesterone daily for the same length of time, very little if any change in size of the reproductive organs results. However, if first the normal condition is restored by giving estrogen and then is followed by the progesterone treatment, the size of the uterus

is maintained but that of the cervix and vagina decreases to an extent approaching that in a castrated animal (Fig. 9.1B). Such experiments show that an estrogen promotes growth of the reproductive tract whereas progesterone is comparatively ineffective when given alone. Yet progesterone can maintain the size of the uterus when administered following an estrogen treatment but it does not prevent involution of the cervix and vagina.

An additional feature of the growth-stimulating action of the ovarian hormones is brought out when estrogen and progesterone are administered concurrently. If, after repair of the reproductive tract of a castrated animal has been accomplished by a series of injections of estrogen, both estrogen (1000 I.U.) and progesterone (1 or 2 mg.) are given daily for 20 days, it will be found that the uterus is larger than when either hormone is given alone for a similar length of time, whereas the cervix and vagina have involuted and are approximately the size found in animals given only progesterone. Thus it can be demonstrated that a synergistic effect on growth of the uterus occurs when the two hormones are given simultane-

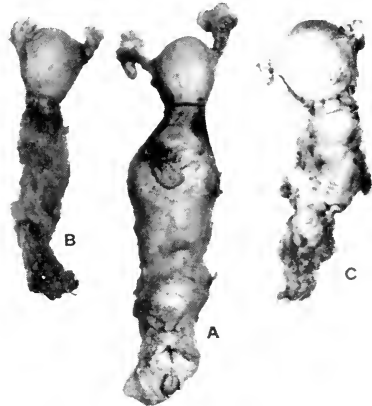

FIG. 9.1. Reproductive tracts of three adolescent monkeys which were castrated and given estrogen daily for approximately 3 weeks. A shows the condition at the conclusion of the estrogen treatment, B the condition following the injection of progesterone for an additional three weeks, and C the effects of continuing the treatment with both estrogen and progesterone for a like period.

ously whereas in the cervix and vagina the growth-stimulating action of estrogen is dominated by progesterone (Fig. 9.1C). This presents a most interesting situation in which the combined actions of two hormones on three closely associated structures of the reproductive tract join in a synergistic effort in promoting the growth of the uterus although progesterone prevents estrogen from affecting growth of the cervix and vagina.

These changes in gross morphology in response to the ovarian hormones are reflected in the histology of the responding tissues. Also, the character of the response differs depending upon the physiologic nature of the tissue concerned; therefore, for the sake of clarity each will be discussed separately. The first of these to be considered is the uterus and particularly growth of the endometrium.

It has been reported (Hisaw, 1935, 1950) that growth of the endometrium, as induced by estrogen, is limited. That is, a dosage of estrogen capable of maintaining the endometrium of a castrated animal for an indefinite period without the occurrence of bleeding, stimulates rapid growth for approximately the first 2 weeks. Within this time a maximal thickness of the endometrium is attained which remains constant or may become less during the course of treatment (Fig. 9.2). Engle and Smith (1935) made similar observations. They found that the endometria of castrated monkeys receiving estrogen for 100 days or longer were thinner than endometria of animals on estrogen for a much shorter time. Also, on prolonged treatment, the stroma of the endometrium becomes dense and the lumen small whereas the size of the uterus remains about the same. In fact, they state that in

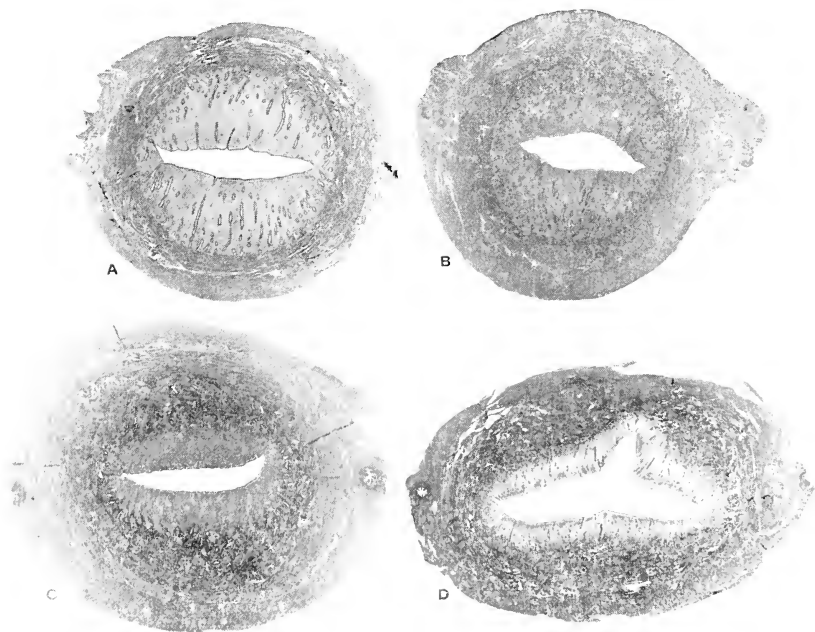

FIG. 9.2. Uteri of four castrated monkeys which were given 10  $\mu$ g. estradiol daily for 10 to 78 days. A was given estrogen for 10 days, B for 30 days, C for 60 days, and D for 78 days. Depression in the endometrium of anterior wall of D is the result of a biopsy taken a year previously. (From F. L. Hisaw, in *A Symposium on Steroid Hormones*, University of Wisconsin Press, 1950.)

four experimental animals the only well developed fundus was found in the animal on the shortest treatment, *i.e.*, 60 days.

The mitotic activity in the epithelium of the glands and surface mucosa also indicates a limited effect of estrogen. This can be demonstrated to best advantage in the endometria of castrated monkeys that have been on estrogen for different lengths of time and have received an injection of colchicine 8 hours before their uteri were removed. A comparison of the number of cells in mitosis per square centimeter of surface mucosa at 10, 30, 45, and 60 days is shown in Figure 9.3. From this it can be seen that mitotic activity approaches that in a castrated animal. Although the five points used in drawing the curve are quite inadequate for an accurate analysis of the mitotic response in the epithelial components of the endometrium, they do show that cell division is most rapid soon after the beginning of an estrogen treatment and subsequently declines.

The loss of responsiveness of the endometrium to estrogen seems related more to the length of treatment than to dosage of hormone. An endometrium of normal thickness can be produced in 2 or 3 weeks at a dosage level of estrogen that will not maintain the growth induced for longer than about 40 days without bleeding (Hisaw, 1935; Engle and Smith, 1935; Zuckerman, 1937b). The response to a low dosage of estrogen that will prevent bleeding during the course of treatment (about 10  $\mu$ g. estradiol-17 $\beta$  daily) is one of rapid endometrial growth at first, as has been described, followed by a thinning of the endometrium. The refractoriness of the endometrium to estrogen becomes so pronounced after about 100 days of treatment that very few cell divisions are seen in the epithelium of the glands and surface mucosa. The general morphology of the endometrium retains the characteristic appearance of the follicular phase of the menstrual cycle except that the stroma is usually more dense and the cells of the glandular epithelium have large deposits of glycogen between the nucleus and the basement membrane. However, metabolically such endometria are surprisingly inactive. Although they are dependent on the presence of estrogen and may bleed within about

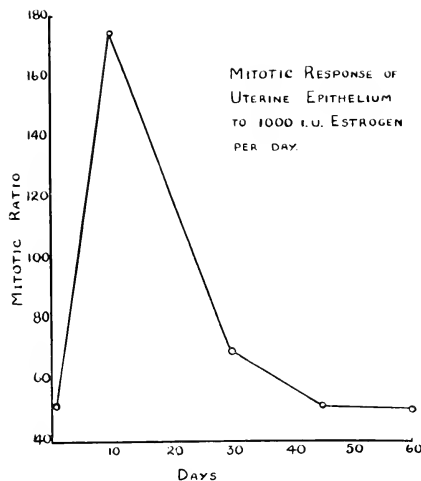

FIG. 9.3. The number of mitoses per square centimeter of surface epithelium of the endometrium in a castrated monkey and in four castrated animals given 10  $\mu$ g. estradiol daily for 10, 30, 45, and 60 days, respectively. One-tenth of actual number of mitoses is shown on the ordinate. (From F. L. Hisaw, in *A Symposium on Steroid Hormones*, University of Wisconsin Press, 1950.)

48 hours if the treatment is stopped, the activity of their oxidative enzymes and the ratio of nucleoproteins (RNA:DNA) are about the same as in the involuted endometria of castrated animals.

The effects that accompany moderate estrogen stimulation become exaggerated in several respects when large doses of estrogen are given for an extended period. The disparity between the area of myometrium and endometrium becomes greater as the treatment progresses (Fig. 9.4). Kaiser (1947) described the destruction of the spiraled arterioles of the endometrium in monkeys given large doses of estrogen and Hartman, Geschickter and Speert (1941) reported the reduction of the reproductive tract to the size of that of a juvenile animal by the end of 18 months during which injections of large doses of estrogen were supplemented by subcutaneous implantation of estrogen pellets. These observations not only show that the endometrium becomes unresponsive to estrogen when the treatment is prolonged but that large doses produce injurious effects.

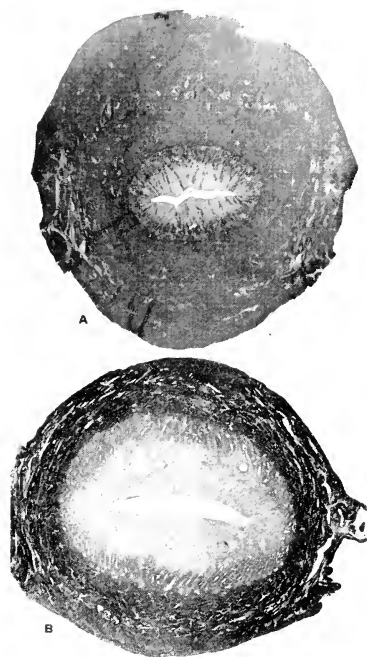

FIG. 9.4. A. Cross-section of the uterus of a castrated monkey which had received 1.0 mg. estradiol daily for 35 days. Compare with B which shows the effects of 1/10 this dosage (100  $\mu$ g. daily) when given for 185 days.

The limited response of the endometrium to estrogen is in some respects surprising in view of its remarkable growth potentialities and regenerative capacity. These qualities were dramatically demonstrated by Hartman (1944) who dissected out as carefully as possible all of the endometrium from the uterus of a monkey and wiped the uterine cavity with a rough swab and yet the undetected endometrial fragments that remained were capable of restoring the entire structure. Also, considering the enormous increase in size of the uterus during gestation, it is even more difficult to account for the rather sharp limitation of growth under the influence of estrogen.

The increase in tonus of the uterine musculature, a known effect of estrogen, has been considered as possibly exercising a restrictive influence on growth of the endo-

metrium. An attempt has been made to remove this containing influence the muscle may have by making an incision through the anterior wall of the uterus (Hisaw, 1950). A castrated monkey was given 10  $\mu$ g. estradiol daily for 21 days at which time the operation was performed and the treatment continued with 30  $\mu$ g. estradiol daily for 40 days. The uterus was laid open by a sagittal incision from fundus to cervix and most of the endometrium was removed from the anterior wall. This caused gaping of the incised uterus and exposure of the endometrium on the posterior wall. The incision was not closed and after hemorrhage was completely controlled the uterus was returned to the abdomen.

Examination of the uterus at the conclusion of the experiment showed no indications that endometrial growth had been enhanced. The muscularis had reunited and only a few small bits of endometrium were found in the incision (Fig. 9.5). It seemed probable that the purpose of the experiment had been defeated by rapid repair of the uterus. Therefore, a similar experiment was done in which the musculature of the incised uterus was held open by suturing a wire loop into the incision. Yet the incision closed and no unusual growth of the endometrium was detected (Fig. 9.6).

Observations under these conditions are necessarily limited to those made on the uterus when it is removed at the conclusion of an experiment and comparisons must be made between uteri of different animals. Obviously, it would be more desirable if the response of an individual endometrium could be followed during the course of treatment. It is possible to meet most of these requirements under conditions afforded by utero-abdominal fistulae, exteriorized uteri, and endometrial implants in the anterior chamber of the eye. In continuing our discussion we first shall present information obtained by such techniques that have a bearing on the response of the endometrium to estrogen.

The surgical procedure used by Hisaw (1950) for preparing utero-abdominal fistulae for studies of the experimental induction of endometrial growth by estrogen and progesterone was a modification of that used by van Wagenen and Morse (1940) for ob-



FIGS. 9.5 and 9.6

The uteri of these two castrated monkeys were opened from fundus to cervix by an incision through the anterior wall while the animals were receiving estrogen. Part of the endometrium of the anterior wall was removed and the incision in the myometrium was not closed.

FIG. 9.5. Estradiol, 10  $\mu\text{g.}$ , was given daily for 7 days; the uterus was opened and the animal continued on 30  $\mu\text{g.}$  estradiol daily for 40 days. (From F. L. Hisaw, in *A Symposium on Steroid Hormones*, University of Wisconsin Press, 1950.)

FIG. 9.6. Estradiol, 10  $\mu\text{g.}$ , was given daily for 7 days; the uterus was opened and the treatment continued at a dosage of 30  $\mu\text{g.}$  estradiol daily for 20 days. (From F. L. Hisaw, in *A Symposium on Steroid Hormones*, University of Wisconsin Press, 1950.)

serving changes in the endometrium during the normal menstrual cycle. This procedure makes frequent inspections possible either by hand lens or dissecting microscope, of most of the upper part of the endometrium on the anterior and posterior walls of the uterus. The elliptic slit formed by the endometrium of the two opposing walls can be located easily, the two sides pressed apart by any small smooth instrument, and the surface of the endometrium examined. Changes in thickness of the endometrium cannot be ascertained without resorting to biopsies but it is free to grow out of the opened uterus if it is so inclined. However, in such preparations the growth produced in the endometrium by daily injections of 10  $\mu\text{g.}$  estradiol for periods of 2 or 3 weeks is not sufficient to show any tendency whatever to grow out through the fistular opening or obstruct examination of the walls of the uterus. The limited growth observed in these experiments is in agreement with that obtained with estrogen on intact and incised uteri.

The cervix uteri of the rhesus monkey is sufficiently long to make it possible to bring the entire fundus to the exterior through a midabdominal incision. Advantage of this

was taken in an attempt to exteriorize the uterus and maintain it outside the body for long enough periods to make it possible to study the growth responses of the endometrium (Hisaw, 1950). These preparations did not prove satisfactory in all respects but they did contribute a number of interesting observations.

The operational procedure used in these experiments involved dividing the uterus transversely from fundus to cervix so that the anterior wall was deflected downward and the posterior wall upward (Fig. 9.7). The endometrium of the exteriorized uterus is difficult to maintain but with proper care it seems to retain its normal condition for at least the first few days after the uterus is opened. Small localized areas of ischemia can be seen to come and go, probably action of the coiled arteries, and there is a periodic general blanching of the endometrium associated with rhythmic contractions of the muscularis. This, however, does not seem true of the whole endometrium. A zone surrounding the internal os of the cervix tends to retain its blood-red color even during strong contractions of the uterus and the growth reactions of the endometrium in this area are of particular interest.

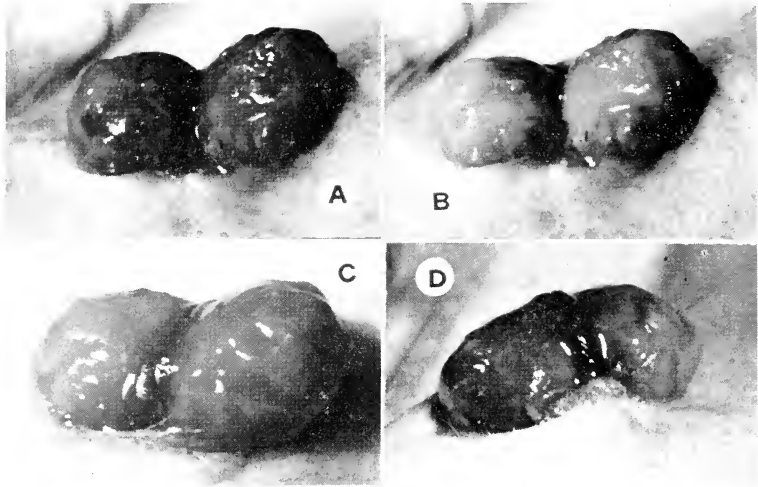

FIG. 9.7. Exteriorized uteri. The uteri were divided transversely from fundus to cervix. The anterior half is seen deflected to the right and the posterior half to the left. *A* and *B* are of the same uterus taken 13 days after exteriorization showing the "blush" and "blanch" reaction of uterine contractions. It can be seen that during blanching the endometrium of the cervix does not become ischemic. *C*. Uterus 18 days after exteriorization, showing response to estrogen. Ridges formed by growth of the endometrium surrounding the internal os of the cervix can be seen at the upper edge of the photograph. *D*, taken 83 days after exteriorization, shows response produced by a series of injections of 10  $\mu$ g. estradiol and 1 mg. progesterone daily. The transverse ridge is formed by the two opposed lips of endometrium derived from the area surrounding the internal os of the cervix. Growth when the two hormones are given is greater than when only estrogen is injected. (From F. L. Hisaw, in *A Symposium on Steroid Hormones*, University of Wisconsin Press, 1950.)

The endometrium on the exposed anterior and posterior halves of the uterus underwent deterioration despite the best of care that could be given, but that surrounding the internal os of the cervix survived and retained its capacity to grow, in one animal, for as long as 9 months. When estrogen was given this endometrium grew rapidly and within a few days stood out as large elliptic lips surrounding the internal os (Fig. 9.7). Within 2 to 3 weeks the lips appeared to reach their full size and further growth was slow or absent. When estrogen treatments were discontinued the endometrial lips underwent bleeding within a few days and were entirely lost. At no time were activities observed that could be ascribed to coiled arterioles, nor did ischemia occur during involution previous to bleeding. It seems that the response of this tissue to estrogen is like that found in other experiments but the absence of ischemia preceding bleeding is ex-

ceptional. The endometrium on the anterior and posterior walls of uterine fistulae invariably showed ischemia for several hours before active bleeding following the withdrawal of estrogen.

Markee (1940) approached the problem of endometrial growth in monkeys by studying the changes that occur in bits of endometrial tissue transplanted to the anterior chamber of the eye. Such transplants retain in large measure the normal morphology of endometrial tissue and changes in their cyclic growth parallel those going on simultaneously in the uterus. So much so that if the animal has an ovulatory cycle, the ocular implants show conditions characteristic of both the follicular and luteal phases, but if ovulation fails to occur then the luteal phase is omitted. Also, the morphologic events taking place at menstruation can be seen and recorded, since the transplants regress and bleed at each menstrual period.



These ingenious experiments will be referred to often in the course of our discussion but at present the response of endometrial transplants in the eye to estrogen is of primary interest.

Monkeys having ocular transplants were given 200 to 300 R.U. of estrone daily for about 1 to 3 months. The transplants did not grow to a certain size and then remain stationary, but instead periods of rapid growth were interrupted by periods of regression which usually involved a marked decrease in size, and if regression was extensive and rapid, bleeding ensued. It also was found that these episodes of regression in the transplants were usually accompanied by a decrease in the size of the uterus.

Comparisons between the results of these experiments and those we have discussed previously may be misleading since it seems that only 1 of the 5 animals (no. 295) used was castrated. Also, the dosage of estrogen was not sufficient to maintain the endometrium of the uterus for an indefinite period without bleeding and this also was reflected in the transplants. It seems questionable that the growth capacity of endometrial transplants in the eye can be determined unless sufficient estrogen is given to prevent bleeding in the uterus. Therefore, it would seem that these experiments contribute less to an analysis of the effects of estrogen on endometrial growth than they do to an understanding of the events that precede and accompany menstruation.

In summary, it seems clear that the outstanding effect of estrogen on the uterus of the monkey is one of growth (Allen, 1927, 1928). The involuted uterus of a castrated animal can be restored to its normal size in 2 or 3 weeks by daily injections of adequate amounts of estrogen. At this time there is an increase in vascularity, a clear-cut hyperemia as seen in rodents. There also is secretion of luminal fluid (Sturgis, 1942) but this does not distend the uterus as in the mouse and rat. This is accompanied by an increase in tissue fluid, especially in epithelial tissues (surface epithelium and glands), and in the connective tissue of the stroma. Glycogen may be present at the basal ends of epithelial cells beneath the nuclei (Overholser and Nelson, 1936) but it apparently is not readily released under the action of estrogen

alone (Lendrum and Hisaw, 1936; Engle and Smith, 1938). The glands of the endometrium maintain a straight tubular structure with some branching near the muscle layers. The condition produced experimentally in the monkey's uterus by short term treatments with estrogen is equivalent to that present in the normal animal at mid-cycle, or even a few days later if ovulation does not occur.

If, however, an estrogen treatment is continued for several months conditions develop in the uterus that are not found during the follicular phase of a normal menstrual cycle. When the daily dose of estrogen is small menstruation occurs at intervals during the treatment (Zuckerman, 1937b) and probably marks periods of endometrial regression as observed by Markee (1940) in eye transplants, but if the dosage is increased by a sufficient amount (about 10  $\mu$ g. estradiol-17 $\beta$  daily) injections may be continued for a year or longer without bleeding. Although the size of the uterus remains within the range of normal variation as the injections are continued, the myometrium tends to increase in thickness and the endometrium becomes thinner, a condition not corrected by further increases in dosage or by prolonging the treatment. The cause responsible for the limited response of the endometrium under these conditions is not known but apparently is not a restrictive influence of the myometrium as similar responses are given when the endometrium is exposed by incising the uterus, in abdominal fistulae, and in exteriorized uteri.

### III. Effects of Progesterone on the Uterus

It has been mentioned that a menstrual cycle, in which ovulation occurs, can be conveniently divided into a follicular and a luteal phase. The follicular phase extends from menstruation to ovulation and the luteal phase from ovulation to the following menstruation. It has been shown in the previous discussion that the endometrial modifications characteristic of the follicular phase of the cycle can be duplicated in a castrated monkey by the injection of estrogen. Likewise, the progestational condition characteristic of the luteal phase can be developed by giving progesterone. In fact, all

the morphologic and physiologic features that are known for anovulatory and ovulatory cycles can be reproduced in castrated monkeys by estrogen and progesterone.

If one designs an experiment to simulate the normal cycle in a castrated monkey then estrogen should be given first to develop the conditions of the follicular phase followed by progesterone for the progestational development of the luteal phase. Experience has shown that this is the most effective procedure for the production of a progestational endometrium. Progesterone, as compared with estrogen, is a weak growth promoter and although it can produce progestational changes in the atrophic endometrium of a castrated monkey when given in large doses, its action is greatly facilitated when preceded by estrogen. The first experiments in which progesterone was used for this purpose were planned on this principle (Hisaw, Meyer and Fevold, 1930; Hisaw, 1935; Engle, Smith and Shelesnyak, 1935).

The first noticeable effect of progesterone is an elongation of the epithelial cells of the surface membrane and necks of the glands. When the treatment is continued, this effect progresses down the gland towards the base. This change is followed closely by a rearrangement of the nuclei which is more pronounced in the glands than in the surface epithelium. The nuclei under the influence of estrogen in doses which reproduce the conditions of the follicular phase of a normal cycle, are situated mostly in the basal

half of the cells, some of them touching the basement membrane. The nuclei retreat from the basement membrane when progesterone is given leaving a conspicuous clear zone. This zone is produced by intracellular deposits of glycogen. These early changes usually appear before pronounced spiraling and dilation of the glands.

Secretion begins in response to estrogenic stimulation and increases greatly as progestational changes are established. It appears first in the necks of the glands and progresses basalward. The surface epithelium takes a less conspicuous part in secretion and is usually reduced to a thin membrane when injections of progesterone are continued until a fully developed progestational endometrium is established. This progressive action of progesterone is such that it is possible to find all conditions in a single gland from active secretion and fraying in the neck region through primary swelling to an unmodified condition at the base.

When treatment is continued for 25 to 30 days at doses of about 2.0 mg. daily, the glands enter a state that has been called "secretory exhaustion" (Hisaw, 1935). This condition also is seen first in the necks of the glands and progresses toward the base. The glandular epithelium decreases in thickness, and active secretion, as judged by fraying of the cells, is absent. The glands may become narrow and straight and the endometrium may resemble that in castration atrophy. These involutionary changes become even more pronounced if the treatment is continued for several months or a year (Fig. 9.8). The endometrium by this time is extremely thin. The glands are straight, short, and narrow, and the stroma very dense. The myometrium is thick in proportion to the endometrium and the uterine blood vessels are large and have greatly thickened walls. Such uteri tend to be somewhat smaller than normal and are soft and pliable.

Thus, it is seen that when growth is produced in the endometrium of a castrated monkey by giving estrogen and then continued on injections of progesterone, there follows a sequential development of all stages of the luteal phase of a normal menstrual cycle terminating in secretory exhaustion. However, this condition cannot

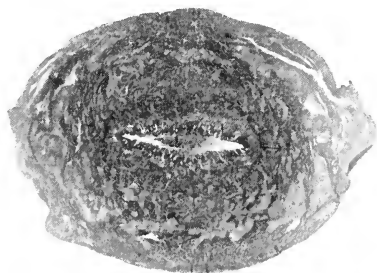

FIG. 9.8. Uterus of a castrated monkey which was given 2 mg. progesterone daily for 113 days. The endometrium is thin but bleeding occurs when such treatment is stopped. The myometrium is soft and pliable and the blood vessels are enlarged and have thick walls.

be maintained by continuing the progesterone treatment, and involutary processes set in and the endometrium is reduced to a thin structure. Yet, such degenerate endometria are dependent upon progesterone and will bleed within about 48 hours if the injections are stopped. It also was found that after discontinuance of progesterone daily injections of 10  $\mu$ g. estradiol may not prevent bleeding.

#### IV. Synergism between Estrogen and Progesterone

There is considerable evidence that in primates progesterone under normal conditions rarely if ever produces its effects in the absence of estrogen. Large quantities of estrogen are present in human corpora lutea (Allen, Pratt, Newell and Bland, 1930) and during pregnancy the placenta secretes estrogens as well as progesterone (Diezfalusy, 1953). This apparently is a common feature of primates, as indicated by the excretion of estrogens in the urine of pregnant chimpanzees and rhesus monkeys (Allen, Diddle, Burford and Elder, 1936; Fish, Young and Dorfman, 1941; Dorfman and van Wageningen, 1941). Also, correlated with this is the observation that estrogen and progesterone when given concurrently produce a greater effect on the uterus of castrated monkeys than either alone (Hisaw, Greep and Fexold, 1937; Engle, 1937; Hisaw and Greep, 1938; Engle and Smith, 1938) and that an ineffective dose of progesterone is greatly potentiated by estrogen. This synergistic effect of the two hormones on the uterus of monkeys is quite different from their action on the uteri of laboratory rodents and rabbits. In these animals the effects of progesterone can be inhibited quite easily by a surprisingly small dose of estrogen (see chapter 7).

The synergism between estrogen and progesterone in the promotion of endometrial growth can be demonstrated to best advantage under the conditions of some of the physiologic preparations that have been discussed. For instance, it was shown (Fig. 9.5) that growth of the endometrium under the influence of estrogen was not enhanced by relieving muscle tension by a midline incision through the anterior wall of the uterus. Now, if a similar operation is per-



FIG. 9.9. Uterus of a castrated monkey that received 10  $\mu$ g. estradiol and 1 mg. progesterone daily for 18 days, at which time the uterus was opened from fundus to cervix and most of the endometrium of the anterior wall removed. The incision was not closed and the treatment was continued for an additional 20 days. (From F. L. Hisaw, in *A Symposium on Steroid Hormones*, University of Wisconsin Press, 1950.)

formed on the uterus of a monkey that is receiving 10  $\mu$ g. estradiol daily and the treatment continued with the addition of a daily dose of 1 mg. progesterone, there usually follows a rapid growth of endometrial tissue out through the incision until by about 3 weeks a mass is formed which approximates the size of the entire uterus (Fig. 9.9). If this experiment is repeated and the same dosage of progesterone is given without estrogen, there is no outgrowth of the endometrium (Fig. 9.10).

A similar synergistic action can be seen in utero-abdominal fistulae. We have mentioned that estrogen does not cause excessive growth of the endometrium under these conditions. However, endometria that have reached their maximal response to estrogen will show a resumption of growth if 1 or 2 mg. progesterone are added daily to the treatment. By the 4th or 5th day lobes of blood-red endometrium begin to protrude

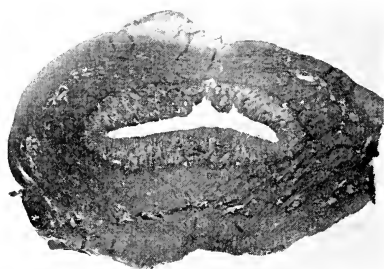

FIG. 9.10. Uterus of a castrated monkey which was given 1 mg. progesterone daily for 18 days following an estrogen treatment. The uterus was opened as described for Figure 9.9, and the injections of progesterone continued for 20 days. (From F. L. Hisaw, in *A Symposium on Steroid Hormones*, University of Wisconsin Press, 1950.)

through the opening of the fistula. Within a few days tongue-like processes of endometrial tissue are thrust out of the opening with each uterine contraction and are entirely or partially withdrawn at each relaxation.

Such outgrowths are difficult to protect from mechanical injury and consequent tissue loss so it is not possible to determine accurately how much endometrium is produced in a given time. In one experiment an animal was kept on 10  $\mu$ g. estradiol and 2 mg. progesterone daily for 98 days and it was found that the endometrium continued to grow, but the rate seemed considerably slower toward the conclusion of the treatment than at the beginning. How long an endometrium would continue to grow under these conditions was not determined, but it is obvious that much more endometrial tissue was produced by the treatment than is ever found at one time in the uterus of a monkey during a normal menstrual cycle. This takes on added significance when it is compared with the endometrial response in the intact uterus of an animal given the same dosage of estrogen and progesterone for a similar length of time.

The progestational development of the endometrium, when both hormones are given, passes through the same stages as those following the injection of only progesterone; *i.e.*, presecretory swelling of the glandular epithelium, active secretion, and

secretory exhaustion. The endometrium, however, is considerably thicker than when a comparable dose of progesterone is given alone, and secretory exhaustion may not be so pronounced by the 30th day (Fig. 9.11). The glandular epithelium in the necks of the glands may be reduced to a thin membrane scarcely thicker than the nuclei whereas some secretion is usually present in the dilated basal parts of the glands. Also dilation of the glands in the basalis is more pronounced following a 30-day estrogen-progesterone treatment than when the same amount of progesterone is given separately.

Secretory exhaustion appears to be the initial indication of an involutionary process that ensues when an estrogen-progesterone treatment is continued for a long time (Hisaw, 1950). When a combination of the two hormones, known to be capable of producing a large uterus with a thick, fully developed, progestational endometrium within about 20 days, is given for 100 days, an astonishingly different endometrium results (Fig. 9.12). It is thin, the stroma is dense and the narrow straight glands are reduced to cords of cells in the basal area. The condition is one suggesting inactivity and atrophy.

When such dosages of estrogen and progesterone are given to castrated monkeys for 200 days or a year further changes in the endometrium occur. By 200 days the epithelium of the surface mucosa and glands



FIG. 9.11. A late progestational condition produced in the endometrium of a castrated monkey by giving 10  $\mu$ g. estradiol daily for 18 days followed by 10  $\mu$ g. estradiol and 2 mg. progesterone daily for 31 days.

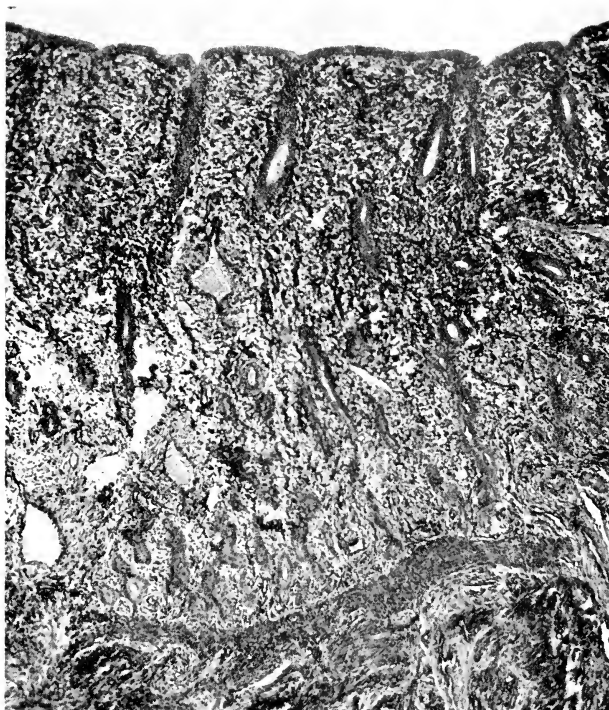

FIG. 9.12. The endometrium of a castrated monkey that had received 10  $\mu$ g. estradiol and 1 mg. progesterone daily for 99 days.

is lost except for small glandular vestiges along the muscularis at the base of the endometrium. There are no glands, coiled arteries, or large blood vessels in what one might yet call the functionalis. All that remains is a modified stroma that resembles decidual tissue (Fig. 9.13A and B). It is also of interest that these endometria will menstruate if the treatment is discontinued and in most if the injections of progesterone are stopped and estrogen continued, but not if estrogen is stopped and progesterone continued.

Even though in such experiments the endometrium has been under the influence of both estrogen and progesterone for a year and has undergone extremely abnormal modification, it yet is capable of responding to estrogen in a more or less characteristic way when progesterone is stopped and in-

jections of estrogen continued. Apparently within about three weeks the modified endometrium is replaced, under the influence of estrogen, by one that has few glands which tend to be cystic, a mesenchymatous stroma, and no coiled arteries (Fig. 9.14).

Under similar circumstances, if estrogen is stopped and progesterone is continued, the modified endometrium is lost without bleeding and there is almost no repair of the endometrium even after a period of 3 weeks. There seems to be an incompatibility between the epithelial outgrowths from the mouths of the glands and the underlying stroma of the denuded surface. Consequently the epithelium crumbles away and epithelization of the raw surface is not accomplished (Fig. 9.15). How long this condition could continue has not been determined.

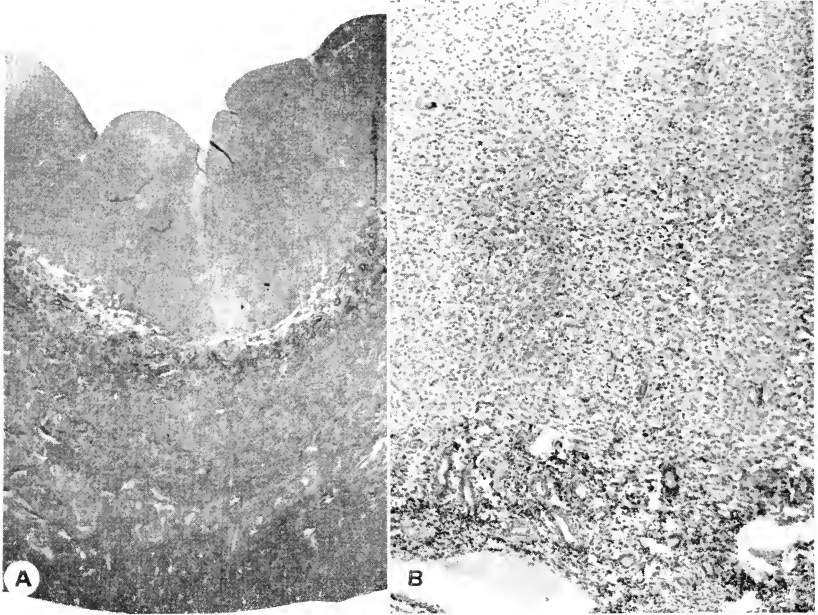

FIG. 9.13. The endometrium shown in *A* is that from a castrated monkey which had received 10  $\mu\text{g}$ . estradiol and 2 mg. progesterone daily for 200 days. In *B*, part of the endometrium of a similar animal given the same treatment for 312 days is shown at a higher magnification. The endometrium is almost entirely a modified stroma in which glandular epithelium and coiled arteries are absent. Only vestiges of glands are present in the basal area next to the myometrium.



FIG. 9.14. Uterus of a castrated monkey which was given 10  $\mu\text{g}$ . of estradiol and 2 mg. progesterone daily for 307 days at which time the injections of progesterone were stopped and estrogen continued for 20 days. Bleeding occurred the second day following discontinuance of progesterone. The absence of coiled arteries and the presence of cystic glands and a mesenchymatous stroma characterize the endometrium.

One of the most interesting aspects of these observations is that these effects were produced by dosages of estrogen and progesterone that are very probably within the range of normal physiology. From this it appears that although growth of the endometrium is greater when the two hormones are given together, due to their synergistic interaction, this does not prevent involutionary changes from setting in when the treatment is continued for a period of weeks or months. In fact, greater damage to the endometrium occurs under the simultaneous action of the two hormones than when either is given alone. Also, increasing the dose intensifies the damaging action of both estrogen and progesterone, so much so that very large doses will almost completely destroy the endometrium.

The myometrium, however, shows a different response to these treatments. Estrogen stimulates myometrial growth, which is

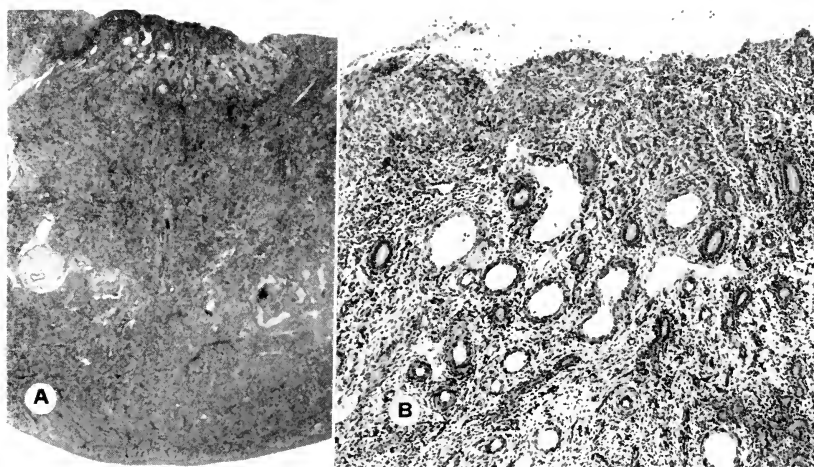

FIG. 9.15. Uterus of a castrated monkey which was given 10  $\mu$ g. estradiol and 2 mg. progesterone daily for 275 days at which time estrogen was stopped and progesterone was continued for 21 days. *A* shows the thin endometrium and dense stroma whereas *B* shows failure of formation of a surface epithelium following the loss of the modified functionalis presumably present at the conclusion of treatment with both hormones (see Fig. 9.13).

intensified both by chronic treatment and high dosage, and seems to be equally effective when it is given alone or in combination with progesterone. Progesterone also promotes growth of the muscularis but seems less effective than estrogen and differs from it by causing pronounced thickening of the walls of the arcuate blood vessels. These vascular changes extend to the coiled arteries of the endometrium, which are also affected by high dosages of estrogen. It seems remarkable that estrogen is capable of preventing the action of progesterone on the myometrial blood vessels and correcting such effects after they are produced and yet at the same time it assists in the destruction of the coiled arteries in the endometrium.

#### V. Experimentally Produced Implantation Reactions

Progesterational endometria of the normal menstrual cycle or those produced in castrated monkeys by progesterone, if mechanically traumatized, will develop endometrial proliferations which seem identical with those found at normal implantation sites of fertilized ova (Figs. 9.16 and 9.17) (Hisaw,

1935; Hisaw, Greep and Fevold, 1937; Wislocki and Streeter, 1938; Rossman, 1940). The proliferated cells originate from the surface and glandular epithelium and grow into the surrounding stroma. The reaction spreads from the point of injury and within a few days may involve the entire inner portion of the endometrium bordering the lumen. The implantation plaques on the 3rd or 4th day present a fairly homogeneous appearance but soon thereafter certain cells attain the proportions of giant cells and many are multinucleated.

The development of the plaques is most rapid during the first week, by the end of which cell division is found only in the basal half of the proliferation and evidence of regression is seen in the superficial portion adjoining the uterine lumen. After 10 days degenerative and phagocytic processes are the dominant features and by 24 days the uterus contains few or no proliferation cells. Wislocki and Streeter (1938) found that implantation plaques during pregnancy and those experimentally induced underwent approximately the same development and subsequent degeneration except for modifications produced by the invading tropho-

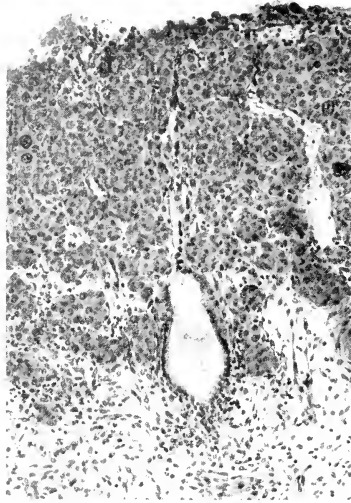

FIG. 9.16. An area of the normal implantation site of a developing ovum. (From Carnegie Institution, No. C467.)

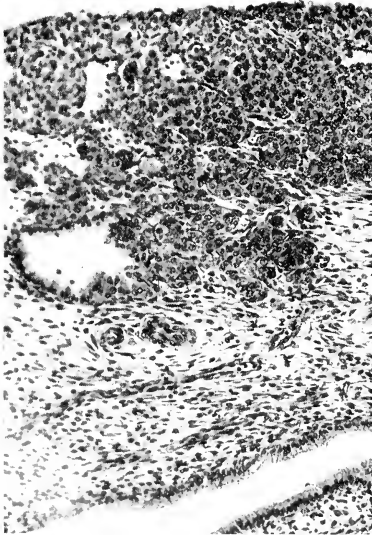

FIG. 9.17. An experimentally induced implantation reaction in a castrated monkey showing condition 6 days after mechanical traumatization of the endometrium.

blast. Rossman (1940) made an extensive morphologic study of these epithelial proliferations and concluded that they should be regarded as typical metaplasias with an embryotrophic function.

## VI. The Cervix Uteri

The cervix uteri of the rhesus monkey is remarkable for its size and complexity. It forms a large segment that is set off from the fundus by a conspicuous constriction at the level of the internal os (Fig. 9.1). A sagittal section (Fig. 9.18) shows the cervical canal not straight but thrown into several sharp turns by colliculi that extend from its walls into the lumen. The largest of these projects from the midventral wall. The functional advantage of such tortuosity of the cervical canal is not obvious but since the cervix probably serves as a barrier between the bacterial flora of the vagina and the corpus uteri, this may be a useful adaptation.

The physiology of the cervix has received much less attention than has been given the uterus. This is regrettable in view of the consideration it must receive in practical obstetrics and gynecology, as well as the possibility that physiologically the monkey cervix may be homologous with that of the human regardless of morphologic differences. Recent observations indicate that this is indeed quite probable.

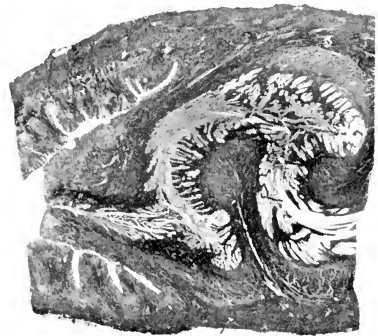

FIG. 9.18. Sagittal section of the cervix from a normal monkey. The vagina and the external os of the cervix are shown at the left and the entrance to the fundus is at the right.





Fig. 9.19. Sagittal section of the cervix of a pregnant monkey showing conditions present just previous to parturition on the 154th day of gestation. The dominant features are dilation of the cervical canal and reduction of the cervical lips (shown at the left) and the colliculi. (From Carnegie Institution, No. C713.)

Hamilton (1949) made a detailed study of the changes in the cervix of rhesus monkeys during the menstrual cycle, paying particular attention to alterations that took place in the cells of the surface epithelium of the endocervical canal and the cervical glands. It was found that heights of the cells showed consistent increases and decreases during the cycle. The peaks came on the 3rd, 13th to 15th, and 22nd days, the greatest of these being the 14th day which is approximately the time of ovulation. It also was observed that, following a peak, secretion was associated with the decline.

Attention was called by Hamilton to the rather close correlation between the fluctuations in height of the cervical epithelium in monkeys and the fluctuations observed by Markee and Berg (1944) in the blood estrogens of the human menstrual cycle. It was concluded that, if similar changes in estrogen levels also occur in monkeys, one would be justified in concluding that the increase in cell height in the cervical mucosa was due to the action of estrogen and the sudden periodic drops in blood estrogen caused secretion and consequent regression. However, it is not clear how this could account for the abundant secretion of the cervical glands in

the presence of high levels of estrogen during late pregnancy (Fig. 9.19).

Much has been learned regarding the physiology of the primate cervix from experiments on castrated monkeys. The cervical mucosa is very responsive to estrogen and castration atrophy can be repaired and a normal condition maintained by daily injections of small doses. Cervical secretion may become abundant when an estrogen treatment is prolonged and especially if large doses are injected. However, the amount of secretion induced by estrogen never equals that of the last half of pregnancy, and it usually subsides if the injections are continued for several months.

Under conditions of chronic treatments with estrogen metaplastic aberrations invariably appear in the epithelium of the endocervix. This reaction was first reported in monkeys by Overholser and Allen (1933, 1935) and has been confirmed by many investigators (Engle and Smith, 1935; Hisaw and Lendrum, 1936; Zuckerman, 1937e). Similar lesions may be found in the cervix uteri of women (Fluhmann, 1954). They seem especially prone to occur under conditions characterized by excessive production of estrogen, such as hyperplasia of the

endometrium (Hellman, Rosenthal, Kistner and Vardon, 1954) and granulosa-cell tumors of the ovary. Various degrees of metaplasia may occur in the cervix during pregnancy both in the mother and newborn but Fluhmann (1954) did not find it as frequently as in nonpregnant women.

This reaction to estrogen as seen in the cervix of castrated monkeys is initiated by growth of small undifferentiated cells below the columnar mucous cells of the secretory epithelium. Fluhmann (1954) suggests that these cells are really undifferentiated cells of the cervical mucosa which have the potentiality of becoming columnar or squamous or simply undergoing multiplication and remaining as indifferent or reserve cells. These cells accumulate, in response to estrogen, to form aggregates of several cells in thickness and, although this may occur in any area of the endocervix, it is generally more pronounced below the base of the glands. As this process proceeds the columnar mucous cells are pushed outward and are finally desquamated thus exposing the underlying metaplastic cells to the lumen of the gland (Fig. 9.20).

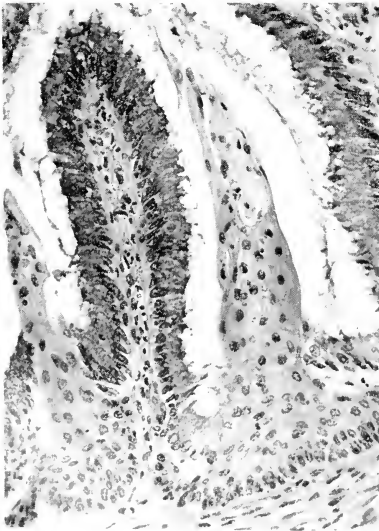

Fig. 9.20. Metaplasia of the cervical epithelium in a castrated monkey that had received 1 mg. estriol daily for 48 days.

The cells of these lesions undergo a characteristic differentiation. When first formed they are small, cuboidal, and have spherical nuclei with dense chromatin. As they increase in number those in the center of the cellular mass become larger and acquire an eosinophilic cytoplasm. Such collections, as seen at the base of the cervical glands, may grow in height and form cone-shaped masses with the apex protruding through the mucous epithelium into the lumen or they may remain as more or less compact structures. This difference in growth seems to have a general relation to the dosage of estrogen. Large doses cause more rapid growth and cone formation with the loss of cells from the apex either singly or in groups, whereas small doses produce slower growth and desquamated cells are seldom seen in the lumen. However, regardless of the rate of growth, the cells at the base of the lesion remain undifferentiated and continue as the principal area of cell proliferation.

Pearl formation is occasionally seen and may be quite common in animals on low dosages of estrogen. Under strong estrogenic stimulation and consequently rapid growth, these structures apparently are desquamated before they are completely formed. However, very early stages are frequently seen and may even be present in small clumps of metaplastic cells, but they are more commonly found in the larger collections at the base of the glands. Their appearance is initiated by swelling and disintegration of one or more adjacent cells that form a center around which epidermidization takes place. Further development does not proceed under the influence of estrogen, beyond the formation of a small central cavity.

The most conspicuous difference between the metaplastic growths produced by estrogen and true cancer of the cervix in the monkey (Hisaw and Hisaw, Jr., 1958) is that the former remain noninvasive even when the treatment is continued well over a year. They also involute when the treatment is discontinued and they do not appear when progesterone is given simultaneously with estrogen. When the injections of progesterone are started after metaplastic growths have been formed in response to estrogen, further growth is inhibited and

the keratinized cells of the lesion become vacuolated and are lost.

In contrast with the effects of estrogen on the cervix, the modifications that occur as pregnancy advances are remarkable. The cervix becomes a soft thin-walled structure, the glands increase in number, and their lumina become greatly enlarged, pressing the stroma into thin partitions between them, and the amount of mucus secreted is enormous (Fig. 9.19). Attempts at duplicating these changes in castrated animals by hormone therapy have been only partially successful. Estrogen produces a solid thick-walled cervix that tends to be larger than normal, an effect that is especially noticeable in young animals. Progesterone does not promote cervical growth and repair of the glands unless large doses are given and even then there is little if any secretion. The best results were obtained when both estrogen and progesterone were given and especially so when relaxin was added to the treatment (see chapter by Zarrow).

### VII. The Vagina

The general features of the vaginal smear of rhesus monkeys have been described by several investigators (Allen, 1927; Hartman, 1932; Westman, 1932) and a detailed study of the cellular components at different times of the menstrual cycle has been made by López Columbo de Allende, Shorr and Hartman (1945). The changes in the vagina of a monkey are in most respects like those found for the human being (Papanicolaou, Traut and Marchetti, 1948; López Columbo de Allende and Orías, 1950). Epithelial growth and desquamation of cornified cells continue at all stages of the cycle but at various rates. The epithelium is thinnest at menstruation and gradually increases in thickness during the follicular phase, reaching a maximum at ovulation. At this time there is a well developed basal area in which numerous mitoses can be seen and from which many papillae or "bulbs" extend into the underlying stroma. Above this is an intermediate zone, an interepithelial zone of cornification (so called Dierk's layer), and a heavily cornified outer zone (Fig. 9.21).

Cellular proliferation is less rapid during the luteal phase and apparently cells are

desquamated more rapidly than they are replaced. Consequently there is a decrease in the thickness of the epithelium in the luteal phase which may include an almost complete loss of the cornified zone (Davis and Hartman, 1935). The effects are probably due to progesterone because similar changes are seen following the introduction of progesterone into a treatment in which estrogen is being given.

The vaginal epithelium of a castrated monkey is remarkably sensitive to estrogen. A small daily dose of 5 to 10  $\mu$ g. estradiol will stimulate growth of an atrophic epithelium of 4 to 8 cells in thickness to one of 60 or even 80 layers thick within 3 weeks. One of the first things that is noticed as the vaginal epithelium thickens is the numerous mitotic figures in the stratum germinativum followed by a marked increase in the number of epithelial papillae along the basement membrane. This condition of rapid growth, cornification, and loss of cells into the vaginal lumen is typical of the follicular phase of the menstrual cycle and can be maintained indefinitely.



FIG. 9.21. The vaginal epithelium of a castrated monkey showing growth and cornification induced by estrogen.

Progesterone, in contrast with estrogen, does not produce rapid growth of the vaginal epithelium but at the same time it is not without an effect. The vaginal epithelium, weeks or months after castration, has relatively few papillae projecting from its basal border into the underlying stroma. When progesterone is given, this condition is changed but not in a spectacular way. There is very slow growth without cornification. The epithelium remains thin but the papillae become more numerous. These are mostly small epithelial buds which tend to remain solid but may show enlargement of the cells in their centers.

When estrogen and progesterone are given concurrently, the effects of estrogen on the vaginal mucosa are modified. If an estrogen treatment has continued for a sufficient time to produce full cornification and then progesterone is added, the first indication of an inhibition of estrogen is a decrease in mitotic activity. This is followed by a continuation of cornification and loss of cells faster than they are replaced; consequently, most of the functionalis is lost and the epithelium becomes thinner. There is also a noticeable decrease in the intensity of cornification, which in the monkey is never as pronounced as in rodents, and under these conditions is quite incomplete, each cell retaining a conspicuous nucleus. Partly cornified cells may be present for several weeks

when both estrogen and progesterone are given, but eventually they almost entirely disappear and the epithelium attains a condition resembling that of late pregnancy.

The inhibitory effect of progesterone on the action of estrogen is shown perhaps even better when a castrated monkey having a fully involuted reproductive tract is first given progesterone for a few days and then estrogen is added to the treatment, or when injections of the two hormones are started at the same time. In such experiments estrogen has little effect on the vaginal mucosa even in doses that would produce marked cornification if given alone. These observations show that a fully cornified vaginal epithelium cannot be produced or maintained by estrogen when an effective dosage of progesterone is included in the treatment (Hisaw, Greep and Fevold, 1937).

Estrogens and progesterone are the dominant hormones of gestation and their simultaneous action is reflected by the changes in the vaginal epithelium. The fully cornified vagina, present at the time of ovulation, is gradually modified as pregnancy progresses into a condition strikingly like that seen in experiments when estrogen and progesterone are given concurrently. In late pregnancy the most striking feature of the thin, uncornified epithelium is the presence of numerous epithelial buds extending deeply into the underlying stroma. They may branch and rebranch and along their course there is conspicuous enlargement of the more centrally situated cells among which cavities appear, enlarge, and join each other (Fig. 9.22). It seems quite probable that this process may be of considerable importance in increasing the diameter of the vagina.

### VIII. Sexual Skin

A so-called sexual skin is present in most catarrhine monkeys, is not found in platyrrhine monkeys, and among the anthropoids occurs regularly only in the chimpanzee (Eckstein and Zuckerman, 1956). Changes in the sexual skin during the menstrual cycle have been observed most extensively in the monkey (*Macaca*), the baboon (*Papio*), and the chimpanzee (*Pan*). The sexual skin of the baboon and chimpanzee undergo pro-

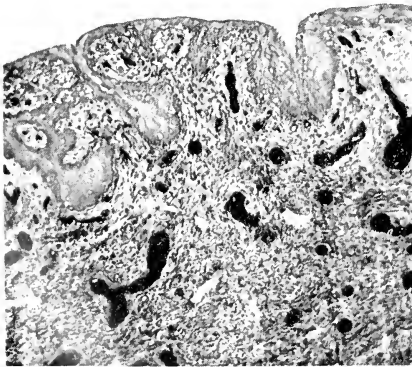

FIG. 9.22. Vaginal epithelium of a pregnant monkey showing condition on the 15th day of gestation. (From Carnegie Institution, No. C713.)

nounced swelling during the follicular phase of the cycle. A maximal size is attained by the middle of the cycle followed by a rapid regression and loss of edema which at least in the baboon is associated with a marked increase in the output of urine (Gillman, 1937a; Krohn and Zuckerman, 1937). The subsidence of the sexual skin begins approximately at the time of ovulation and remains in the reduced condition throughout the luteal phase, followed by a subsequent initiation of swelling during or soon after menstruation (Zuckerman, 1930, 1937e; Zuckerman and Parkes, 1932; Gillman and Gilbert, 1946; Young and Yerkes, 1943; Nissen and Yerkes, 1943).

A well developed sexual skin is present in the monkey (*Macaca mulatta*) only during adolescence. With the appearance of the menstrual cycles the sexual skin undergoes a process of maturation into the adult condition in which cyclic changes in edema are absent and the most noticeable feature is a vivid red color. Such coloration is due to vascular engorgement rather than pigment (Collings, 1926) and involves the perineum, the buttocks, and may extend for various distances down the legs and over the symphysis pubis. The development and maturation of the sexual skin have been described in considerable detail by several investigators (Hartman, 1932; Zuckerman, van Wagenen and Gardiner, 1938).

The sexual skin has been of considerable interest both as to the nature of its responsiveness to ovarian hormones and the manner in which its grossly visible changes during the menstrual cycle parallel events occurring in the reproductive tract. The sudden loss of edema at the conclusion of the follicular phase not only signals ovulation but also raises the question as to whether the loss of tissue fluid is due to a decrease in estrogen or is the direct effect of progesterone. The importance of this becomes obvious when it is considered that a similar process also goes on simultaneously in the endometrium and raises the question again as to the respective roles played by estrogen and progesterone in endometrial growth and menstruation.

That the development and edema of the sexual skin of adolescent rhesus monkeys depend on the ovaries was first demon-

strated by Allen (1927). Involution and loss of color follow castration, and the normal condition can be restored by the injection of estrogen. Also, when estrogen treatment is continued for several weeks maturation of the sexual skin occurs and a condition characteristic of that in the adult is established (Zuckerman, van Wagenen and Gardiner, 1938). The genital area loses its edema and develops a brilliant red color which is retained as long as estrogen is administered. Once this mature condition is established the response of the sexual skin to subsequent estrogen treatments is limited to a change in color.

Similar experiments have been performed on the chacma baboon, *Papio porcarius* (Parkes and Zuckerman, 1931; Gillman, 1937b, 1938, 1940a). The large sexual skin of these animals is very responsive to estrogen and development equal to that of the follicular phase of the menstrual cycle can be readily induced by daily injections for about 2 weeks. However, the perineal swelling of the baboon differs from the sexual skin of the genital area of the rhesus monkey in that it does not "mature" under the influence of estrogen.

When large doses of estrogen are given to a rhesus monkey a generalized edema of the skin occurs beyond the genital area. This first appears as deeply indented swellings along the sartorii from groin to knee, and next appears at the base of the tail and spreads gradually upward until it involves the entire dorsal portion of the trunk. At the same time, the skin of the face, scalp, and supraorbital ridges becomes swollen and finally the edema may extend out on the arms and down the legs to the ankles (Bachman, Collip and Selye, 1935; Hartman, Geschickter and Speert, 1941). A daily dose of 500  $\mu\text{g}$ . or more of estril or estradiol will produce this condition within 2 to 3 weeks and, when the treatment is continued for an extended period the effect tends to subside.

Progesterone has a strong inhibitory action on the effects produced by estrogen on both the genital and extragenital sexual skin of the monkey. If daily injections of progesterone are added to the treatment after full development of the sexual skin has been induced by estrogen, there is a

noticeable loss of edema by the 4th or 5th day followed by rapid involution and reduction of the turgid folds of skin to loose, flabby wrinkles within about 10 days. When estrogen and progesterone are given concurrently to a castrated monkey from the beginning of treatment edema does not appear but the sexual skin regains its normal color. In fact, progesterone alone, like estrogen, can restore the color to the sexual skin of castrated adult monkeys (Hisaw, Greep and Fevold, 1937; Hisaw, 1942).

The interaction of estrogen and progesterone on the sexual skin of rhesus monkeys can best be demonstrated by the reaction of the skin of the sexual area in adolescent animals. The most striking effect and probably the most important is the sequence of events initiated by a single dose of progesterone when given to an animal on continuous estrogen treatment. Under such treatment a full response of the sexual skin is obtained by the end of 20 days. If at this time 1 mg. progesterone is given in a single dose and the estrogen treatment continued uninterruptedly, the first indication of an effect of the luteal hormone is a slight loss of edema and color of the sexual skin on the 4th or 5th day thereafter. The sexual skin is markedly reduced by the 8th day, almost gone by the 9th, and at the end of about a fortnight regains its ability to respond to estrogen as shown by a return of color and swelling. However, the most remarkable eventuation of such treatment is menstruation which usually begins on about the 10th day (Hisaw, 1942).

Involution of the sexual skin and menstruation following a single injection of progesterone also have been produced in the baboon by Gillman (1940a). He found that 5 mg. progesterone, when given on the 8th day of a normal menstrual cycle, would cause an appreciable loss of edema of the swollen perineal sexual skin by the day after injection. This was followed by a progressive involution of the perineum until the 13th day and swelling was re-initiated by the end of the 15th day. Reduction of the sexual skin at this dosage of progesterone was not associated with menstruation. However, when the dose was increased to 20 mg. both deturgescence of the sexual skin and menstruation occurred. These effects pro-

duced by progesterone in the presence of endogenous estrogen have much in common with those described above as occurring in castrated monkeys on continuous estrogen treatments.

### IX. Menstruation

An experimental approach to the physiology of menstruation dates from the observations of Allen (1927) that uterine bleeding would occur in castrated monkeys following the discontinuance of an estrogen treatment. He suggested that normal menstruation is due to a fluctuation in estrogen secretion and proposed the "estrogen-withdrawal" theory to account for the observed facts. This concept led to an extensive investigation of the effects of estrogens on the endometrium and of conditions that modify their action. It was soon found that in both castrated monkeys and human beings there was a quantitative relationship between the dosage of estrogen given and the maintenance of the endometrium. Bleeding occurred during treatment when the daily dose of estrogen was small, but with larger doses a point was reached at which the injections could be continued for months or even years without bleeding (Werner and Collier, 1933; Zuckerman, 1937b, d).

Estrogen also will inhibit postoperative bleeding which usually follows total castration, provided the ovaries are removed before or soon after ovulation (Hartman, 1934). With the advent of a corpus luteum and development of a progestational endometrium it becomes progressively more difficult, following castration, to prevent menstruation by injecting estrogen. Similar results are obtained when estrogen is given during a normal menstrual cycle. Small doses may not prevent the onset of menstruation, but if continued, subsequent menstrual periods are delayed (Corner, 1935). Large doses when given during the luteal phase of the cycle do not disturb the normal menstrual rhythm, but may do so if the treatment is started during the follicular phase (Zuckerman, 1935, 1936a).

Progesterone, in contrast with estrogen, will prevent menstruation from an endometrium representative of any stage of the normal cycle. It will delay onset of the next menses even when the treatment is started only

a few days before the expected menstruation (Corner, 1935; Corner and Allen, 1936). Also, the bleeding that invariably follows the discontinuance of a long treatment with estrogen can be inhibited indefinitely by giving progesterone (Hisaw, 1935; Engle, Smith and Shelesnyak, 1935; Zuckerman, 1936b).

An impression held by many of the earlier investigators was that progesterone could not produce its effects on the primate endometrium unless it was preceded by the action of estrogen. It is true, of course, that progesterone is a comparatively weak growth promoter and its effects can be demonstrated to best advantage on an endometrium that has been developed by estrogen. However, Hisaw, Greep and Fevold (1937) produced a progestational endometrium in a monkey that had been castrated 242 days previously by giving synthetic progesterone. Also, the endometrium of this animal was found capable of forming a decidual plaque upon traumatization. Soon afterwards Hartman and Speert (1941) observed menstruation following the withdrawal of progesterone in castrated monkeys that had not been given estrogen and more recently similar results have been reported by Eckstein (1950). At the same time it has been found that progesterone will induce menstruation in women suffering from amenorrhea and also that uterine bleeding can be precipitated by similar treatment during the follicular phase of the cycle (Zondek and Rozin, 1938; Rakoff, 1946).

These observations have been confirmed and extended by Krohn (1951; 1955) who finds that menstrual bleeding can be induced in monkeys with secondary amenorrhea by the injection of 5 daily doses of progesterone. Progesterone (5 mg. daily for 5 days) also precipitates uterine bleeding in castrated monkeys at intervals of about 8 days provided the treatment is started immediately a menstrual bleeding has been induced either by removal of the ovaries or withdrawal of estrogen. The most interesting aspect of these observations is that the number of short 8-day cycles that can be obtained in this way in a castrated animal seems to be related to the size of the initial dose of estrogen used to induce withdrawal bleeding. This also applies to pro-

gesterone-withdrawal bleeding, so the effect does not depend upon the particular hormone used to obtain the bleeding. It also is of interest that such conditioning of the endometrium to subsequent responses to the 5-day treatments with progesterone may last for several months on a continuous regime. It is surprising that such a series of responses cannot be initiated unless the first injection of progesterone is given within 6 days following the initial withdrawal bleeding. These observations have much in common with those of Phelps (1947) who also studied the influence of previous treatment on experimental menstruation in monkeys.

There seems to be a quantitative relationship between the dosage of progesterone given in combination with estrogen and the ability of estrogen to prevent bleeding after the injections of progesterone are stopped. It has been mentioned that once a fully developed progestational reaction has been produced by progesterone, it is extremely difficult, if not impossible, to inhibit menstruation by giving estrogen following the withdrawal of progesterone. However, Hisaw and Greep (1938) found that progestational endometria produced by small doses of estrogen plus approximately 0.5 mg. progesterone daily for 18 to 21 days did not bleed following progesterone withdrawal when continued on 10 to 20 times the original dosage of estrogen. In fact, such endometria were brought back to a condition typical for the action of estrogen and again transformed into a presecretory progestational state without the intervention of bleeding. Similar observations were made previously by Zuckerman (1936a, 1937d).

These experimental results give grounds for some doubt as to the adequacy of the estrogen-withdrawal theory to account fully for menstruation. Not only can progesterone bring about menstruation without the intervention of estrogen but other steroid hormones are capable of producing similar effects. Desoxycoorticosterone in large doses can inhibit estrogen-withdrawal bleeding in castrated monkeys (Zuckerman, 1939, 1951) and induce phases of uterine bleeding in rapid succession in normal monkeys (Krohn, 1951). So too can testosterone prevent estrogen-withdrawal bleeding (Hart-

man, 1937; Engle and Smith, 1939; Duncan, Allen and Hamilton, 1941) and inhibit progesterone-withdrawal bleeding as well (Engle and Smith, 1939). Testosterone also will precipitate bleeding during an estrogen treatment (Hisaw, 1943) and in normal monkeys if given early in the cycle (Krohn, 1951). Just what specific action these compounds have in common that enables them to produce these effects or whether there are different modes of action that lead to the same results is not known, but, before mentioning certain possibilities, it may be helpful to consider information regarding the influence of estrogen-progesterone interactions on menstruation.

Among the most significant observations regarding primary causes of menstruation are a few indications that there may be an intrinsic difference in the ways in which estrogen and progesterone produce their effects on the endometrium. One of the first indications of this was the discovery that a short series of injections of progesterone during treatment with estrogen will precipitate menstruation (Corner, 1937; Zuckerman, 1937d; Hisaw and Greep, 1938). This can be demonstrated by giving a castrated monkey a maintenance dose of estrogen daily for 2 or 3 weeks, then adding a daily injection of progesterone for 5 to 10 days and continuing the estrogen treatment. As a rule bleeding appears within 2 or 3 days after stopping progesterone. The most interesting point brought out by such experiments is that bleeding can occur under these conditions in the presence of an otherwise maintenance dosage of estrogen.

Perhaps the most surprising as well as most important fact brought out by subsequent experiments was the small amount of progesterone required to bring about bleeding under these conditions. It was found that only a single injection of 1 mg. was required for animals on chronic treatment with a maintenance dose of estradiol (1000 I.U.) and some bled when 0.5 mg. progesterone was given (Hisaw, 1942). The sequence of events following the injection of progesterone can be seen to best advantage in an adolescent monkey whose sexual skin also responds to the estrogen treatment. When the 1 mg. progesterone is given on the 20th day of estrogen treatment the edema of the

sexual skin will have attained its maximal development. The first indication of an effect of progesterone is a slight loss of edema and color of the sexual skin which appears on the 4th or 5th day and by the 9th or 10th day the edema is almost gone and the sexual skin is pale. Blood appears in the vaginal lavage between the 7th and 10th days, of about 70 per cent of the animals on this dosage. The sexual skin may remain markedly reduced and pale until about the 15th day after which both color and edema rapidly return. These effects can also be seen when 1 mg. progesterone is given for a series of days. However, neither the time of appearance nor loss of edema of the sexual skin is significantly hastened, and if the injections extend over no more than 5 days the time between the first injection and bleeding remains approximately the same.

Similar observations have been made by Gillman and Smyth (1939) on the South African baboon (*Papio porcarius*). They found that 3 mg. or more of progesterone when given in a single injection during the follicular phase of the cycle would cause the relatively enormous perineal swellings to pass rapidly through deturgescence and reach a flabby resting condition within 5 to 7 days, and after a delay of about 24 hours once again begin to swell. As much as 10 or 15 mg. in a single dose caused perineal deturgescence without bleeding, whereas 20 mg. in a single dose or a total of 15 mg. if divided into 2 or 3 injections and given at 3 or 4 day intervals, produced both deturgescence and bleeding (Gillman, 1940b). The baboon differs from the monkey in that larger doses of progesterone are required to produce the effects and the sexual skin does not "mature" on repeated treatments and lose its responsiveness; otherwise the basic physiology of the reaction in both animals seems to be the same.

The most important fact brought out by these experiments is that the effects of a single injection of progesterone can continue in the presence of estrogen for as long as 10 to 15 days. It is highly improbable that progesterone lingers in the body for so long a time (Zarrow, Shoger and Lazo-Wasem, 1954). In general it is considered the most ephemeral of the sex steroids and is probably inactivated within at least a few hours



after it is administered. It seems more likely that progesterone modifies the sexual skin in a way that renders it unresponsive to estrogen and that about a fortnight is required to recover the original condition.

This takes on added significance when the possibility is considered that effects similar to those seen in the sexual skin might also be going on simultaneously in the uterine endometrium. An appreciable dehydration of the endometrium occurs just previous to menstruation (van Dyke and Ch'en, 1936) and a loss of interstitial fluid before bleeding has been observed in endometrial implants in the eyes of monkeys and described in detail by Markee (1940). This was shown by periodic regression in size and compactness of the grafts which resulted in a decrease in area of 25 to more than 75 per cent. Because cyclic changes in endometrial grafts in the eye are correlated with events of the menstrual cycle there is reason to believe that similar reactions were going on in the endometrium of the uterus.

Endometrial regression, as described by Markee, did not always lead to menstruation although it invariably preceded, accompanied, and followed menstrual bleeding. Menstruation occurred only when regression was rapid and extensive. This was seen in the endometrial grafts in the eye during a normal menstrual cycle at the time of involution of a corpus luteum and during an anovulatory cycle soon after the involution of a large follicle. It also begins soon after the last of a series of injections of estrogen or progesterone. A slow decrease in size of the ocular grafts, without concomitant bleeding, can be induced in castrated monkeys by gradual withdrawal of estrogen, and when estrogen is given in amounts that are inadequate for maintaining the endometrium for an extended period the "break through" bleeding that eventually ensues is preceded by a rapid and extensive endometrial regression. Because this reaction also occurs when menstruation is induced by such an unusual procedure as spinal transection (Markee, Davis and Hinsey, 1936), it probably is a phenomenon that always precedes menstruation.

It seems from these observations that the changes in the endometrium preceding menstruation are initiated by a sudden with-

drawal of a stimulus on which the endometrium at the time relies for the maintenance of a particular physiologic condition, and bleeding and tissue loss are incidents that occur during the readjustment necessary for the return to an inactive state. What this involves is only partly known, but an understanding of the initial changes in the endometrium that usher in menstruation most certainly holds the explanation of the real cause. This has been a perennial subject for discussion and many suggestions and theories have been set forth in an extensive literature to account for various aspects of menstruation. Among the more recent general discussions are those by Zuckerman (1949, 1951), Corner (1951), and Zondek (1954).

The estrogen-withdrawal or estrogen-deprivation theory proposed by Edgar Allen has received more attention than any other. From what has been mentioned earlier it is clear that this theory can account for uterine bleeding subsequent to the discontinuance of a series of estrogen injections and also perhaps menstruation at the conclusion of an anovulatory cycle. However, it is not so obvious as to how this theory can explain the occurrence of menstruation at the close of the luteal phase of a normal cycle. Estrogen in large doses will not inhibit such bleeding, but it is postponed if progesterone is given. It is equally difficult to see how this theory is helpful in accounting for the fact that a small dose of progesterone will precipitate bleeding in the presence of a maintenance dosage of estrogen. As little as 2  $\mu$ g. progesterone will induce bleeding when applied topically to the endometrial lips of an exteriorized uterus (Fig. 9.7) in a monkey that is receiving 10  $\mu$ g. estradiol daily (Hisaw, 1950).

Uterine bleeding precipitated by administering progesterone during an estrogen treatment has been explained on the grounds that progesterone in some way interferes with the action of estrogen on the endometrium. Therefore, it is assumed that an animal receiving both estrogen and progesterone is in a sense "deprived" of estrogen. That is, when the two hormones are given, simultaneously, progesterone itself is capable of maintaining the endometrium without bleeding; but when it is stopped, the

suggestion is that the animal is physiologically deprived of estrogen and literally deprived of progesterone (Corner, 1951). Although this view is in descriptive agreement with the observed facts the idea of the inhibitory effect of progesterone does not take into consideration the synergistic interaction of the two hormones on the endometrium.

The physiologic function of progesterone is the conversion of an estrogen-endometrium into a progesterational endometrium suitable for receiving and nourishing a developing blastocyst. Such an endometrium is adapted for this specific reproductive function and accordingly its physiologic nature must be quite different from that of the follicular phase of the cycle. Indeed, it is known that these two structures (follicular and luteal phase endometria) are morphologically and biochemically unlike in a number of respects. This gradual transformation, following ovulation, occurs as progesterone becomes the dominant hormone, and consequently, as this proceeds, the endometrium progressively loses competence to respond to estrogen. However, this does not imply that estrogen is without effect in the general economy of the progesterational endometrium. It has been shown in a number of ways that the action of progesterone on the primate endometrium is greatly facilitated by the presence of estrogen. In fact, it seems probable that rarely if ever does progesterone perform its function in the absence of estrogen (Hisaw, 1959; chapter by Zarrow).

After consideration of the endometrial specializations brought about by progesterone, it seems rather pointless to hark back to the follicular phase and inject the past record of accomplishments and prerogatives that estrogen had at that time into the explanation of an entirely different hormonal situation. It seems more in keeping with the facts to state outright that menstruation following the involution of a corpus luteum or the discontinuance of progesterone, even though estrogen is present, is due to a decrease or absence of progesterone.

It also has become less certain that menstruation at the conclusion of an anovulatory cycle is really an estrogen-withdrawal bleeding. This is possible, of course, but at

the same time the exceedingly small amount of progesterone required to induce bleeding in the presence of estrogen makes it difficult to be sure what the situation might be. Even a negative test for progesterone in the blood, by our present methods, does not necessarily indicate the absence of a physiologically effective amount of progesterone. Zarrow, Shoger and Lazo-Wasem (1954) found that in rabbits an intramuscular injection of 40 mg. progesterone was required to produce an appreciable concentration of the hormone in the blood as determined by the Hooker-Forbes method. Yet, 0.2 mg. progesterone daily for 5 days will produce a progesterational reaction in the uterus equivalent to that of the 5th day of normal pseudo-pregnancy. In monkeys 0.5 mg. daily when given with 10  $\mu$ g. estradiol is an adequate dosage of progesterone to induce unquestionable progesterational changes in the endometrium and much less will cause bleeding. These observations indicate that the minimal effective concentration of progesterone in the blood may be less than is possible to detect by our present methods.

This also seems to hold for the human being. Estimates of secretion and metabolism of progesterone in the human being have been based primarily on the recovery of its excretory product sodium pregnanediol glucuronide in the urine. It seems obvious that such determinations must be only general approximations because only about 20 per cent of the progesterone secreted or injected can be accounted for by the pregnanediol in the urine. Also, it is generally known that a physiologically effective dosage of progesterone does not necessarily lead to the excretion of pregnanediol (Hamblen, Cuyler, Powell, Ashley and Baptist, 1939; Seegar, 1940). In other words, the threshold dose of progesterone for endometrial stimulation is below that at which the hormone is excreted as pregnanediol. In fact, it has been suggested by some investigators that there is no quantitative relationship between the progesterone present in the blood and the pregnanediol excreted in the urine (Buxton, 1940; Sommerville and Marrian, 1950; Kaufmann, Westphal and Zander, 1951).

These findings and the wide variation in the amount of pregnanediol excreted during

a menstrual cycle (Venning and Browne, 1937) suggest that, even in the absence of ovulation, sufficient progesterone may be present to influence menstruation. There also is the possibility of progestational hormone from some extra-ovarian source, such as the suprarenal cortex. This was suggested by Zuckerman (1937b, 1941) as a possible explanation for periodic bleeding in monkeys on a constant submaintenance dose of estrogen. This thought becomes more plausible in view of the fact that progesterone is one of the precursors in the metabolic synthesis of androgens, estrogens, and adrenal cortical steroids (Dorfman, 1956). Also, it has been shown that desoxycorticosterone acetate is converted to progesterone *in vivo* (Zarrow, Hisaw and Bryans, 1950). Therefore, progesterone is not restricted to ovarian luteal function but instead is of rather general occurrence in the body and the likelihood is that small amounts are a constant constituent of the blood.

Also, the amount of progesterone from extra-ovarian sources may fluctuate, as suggested by Zuckerman (1949), and consequently disturb the normal menstrual rhythm and probably cause bleeding in monkeys on a continuous submaintenance dose of estrogen. However, as to the latter, there is an alternative explanation. Castrated monkeys on a continuous treatment of 10  $\mu$ g. of estradiol daily do not show "break-through" bleeding, and a synergistic effect on growth of the uterus is seen when 0.5 mg. or more of progesterone daily is introduced into the treatment. However, the simultaneous administration of 0.25 mg. or even 0.125 mg. progesterone daily in similar experiments results in bleeding between about the 10th to 16th day of the combination treatment. Thus, a dosage of progesterone less than that required for synergism or prevention of bleeding when given alone, modifies the endometrium so that it can no longer be maintained by 10  $\mu$ g. estradiol daily (Hisaw, Jr., unpublished). When it is considered that the endometrium becomes increasingly dependent on estrogen during a chronic treatment, even after maximal growth is attained (Hisaw, 1942), it seems plausible that the effectiveness of a dosage of estrogen only slightly above the thresh-

old for bleeding may be decreased sufficiently by the endogenous progesterone from extra-ovarian sources to precipitate bleeding.

Although it is obvious that the normal menstrual cycle is primarily under the control of the ovarian estrogens and progesterone, it is also equally clear that menstruation is not due to a specific hormonal action. Experimental evidence indicates that any natural or synthetic compound having the capacity for promoting growth or sustaining an existing metabolic state in the endometrium is also capable of inducing withdrawal bleeding. However, this does not imply that all compounds capable of inducing menstruation do so by the same biochemical action; in fact, there is considerable evidence that this is not so (see chapter by Villee). Yet in each instance a series of events is set in motion that leads up to active bleeding.

### X. The Mechanism of Menstruation

The immediate cause and mechanism of menstruation has continued to be a topic of special interest for many years and the subject of frequent general discussions. A generalization in keeping with our present knowledge is that no gross morphologic feature of the endometrium is distinctive of menstruation. A menstruating endometrium may be representative of any stage of the follicular or luteal phase of the cycle. The most frequently discussed hypothesis regarding the mechanism of menstruation is that proposed by Markee (1940, 1946) which is based on direct observations of vascular changes in endometrial grafts in the anterior chamber of the eye of monkeys (see p. 564). The changes observed in the endometrium shortly before bleeding are, briefly, as follows. (1) There is extensive and rapid regression of the endometrium due to loss of ground substance from the stroma (Fig. 9.23). (2) The rapid regression brings about a disproportion between the length of the coiled arteries and thickness of the endometrium with the formation of additional coils. (3) The increased coiling of the arteries retards the circulation of blood through them and their branches. This stasis begins 1 to 3 days before the onset of the

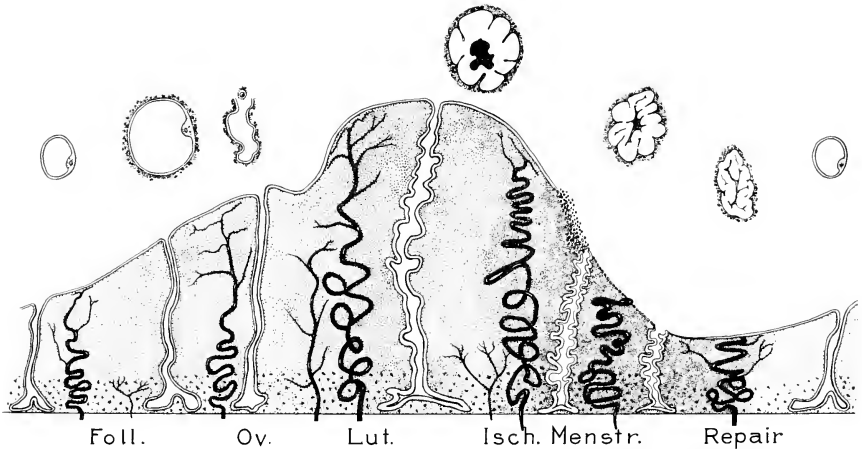

FIG. 9.23. A diagram indicating correlated changes in ovary and endometrium during an ovulatory cycle of rhesus monkey. Thickness of endometrium, density of stroma, gland form, and three types of arteries are indicated. There is a gradual rise in thickness up to the time of ovulation, and a brief decline followed by development of the luteal or progesterational phase with accumulation of secretion in the glands due to relaxation of the myometrium. This is followed by loss of ground substance from the stroma, which is the primary factor in the premenstrual regression of the ischemic phase. This is a prelude to extravasation and shedding of tissue. Incidentally, secretion is extruded and glands collapse. There is further regression throughout the phase of menstruation. More than the basal zone (coarse stipple) survives menstruation. During repair, thickening of the endometrium is associated with increase in ground substance in the stroma and growth in the glands. (From G. W. Bartelmez, 1957, *Am. J. Obst. & Gynec.*, **74**, 931-955, 1957, with some modification of description.)

flow, and is associated with leukocytosis in the endometrium. (4) The portion of the coiled arteries located adjacent to the muscularis constricts 4 to 24 hours before the onset of the flow. This vasoconstriction persists throughout the menstrual period except when individual coiled arteries relax and blood circulates through them for a few minutes. Markee postulated that the immediate cause of menstruation under these conditions was the injurious effect of anoxemia upon the tissues of the endometrium brought about by mechanical compression and constriction of the coiled arteries. Therefore, the coiled arteries and their modifications become the central feature upon which the theory is based.

Although this offers an explanation for many of the facts, it falls short in that now it is known that menstruation can occur in the absence of coiled arteries. Kaiser (1947) showed that no spiral arteries are present in

the endometrium of three species of South American monkeys known to menstruate. He also found that the coiled vessels of the endometrium could be destroyed almost completely by giving large doses of estrogen and yet bleeding followed estrogen withdrawal.

Several experimental conditions under which the coiled vessels of the endometrium are destroyed have been mentioned in the present discussion and in each instance bleeding invariably followed withdrawal of the supporting stimulus. The extremely atrophic endometrium present at the conclusion of a prolonged treatment with progesterone (Fig. 9.8) will bleed when the injections are stopped, and if estrogen injections are started immediately thereafter the endometrium that develops is normal with the exception of the absence of coiled arteries; even so, it also will bleed when the treatment is stopped. Even a more

drastic destruction of endometrial structures occurs when both estrogen and progesterone are given for several months. Not only are the coiled arteries destroyed but also the glands and the luminal epithelium. All that remains is a modified stroma penetrated by a few small blood and lymph vessels and scattered glandular rudiments along the myometrium (Fig. 9.13). Yet, in spite of this, bleeding follows discontinuance of the treatment.

These observations prove conclusively that the spiral arteries of the endometrium do not hold the solution to the menstrual process. However, the descriptive account by Markee of the events that take place in the endometrium during the cycle remains one of the major contributions to our knowledge of the primate endometrium. Phelps (1946) also made a very careful study of the vascular changes in intraocular endometrial transplants in ovariectomized monkeys receiving estrogen and progesterone, and concluded that the primary function of the coiled arteries is concerned with vascularization of the implantation site of a developing embryo.

There also is reason for doubting that ischemia is a determining factor in the menstrual process. That constriction of the endometrial vessels does occur is well established, but that tissue destruction and bleeding are consequences of prolonged anoxemia may be questioned. The endometrium around the internal cervical os as seen in incised exteriorized uteri (Fig. 9.7) contains very few coiled arteries and does not take part in the periodic blushing and blanching of the fundus, but instead remains blood-red even during menstruation. Also, certain tongues of endometrium in a uterine fistula may become crowded by their neighbors to an extent of being partly or completely deprived of blood, yet they do not bleed even though their unfavorable situation leads to deterioration within a few days.

Emmel, Worthington and Allen (1941) attempted to induce menstruation in monkeys by operative ischemia. Circulation to the fundus of the uterus was interrupted by means of a tourniquet for periods of 1 to 8½ hours, and in two instances for 19 hours. This procedure did not precipitate uterine

bleeding nor did it hasten the onset of an expected bleeding following estrogen withdrawal. In fact, when the uterus was deprived of blood for periods longer than 3 hours impairment of the bleeding response to estrogen withdrawal was observed, and 19 hours of ischemia caused atrophy of the uterus without bleeding.

It also has been reported that a toxic substance formed in the endometrium is responsible for menstruation. This menstrual toxin is supposed to be present in the endometrium just previous to and during menstruation, and to be a substance resembling or identical with necrosin, a material found in pleural exudate following an inflammatory reaction (Smith and Smith, 1951). Zondek (1953) reports that menstrual blood, when obtained under relatively sterile conditions, is no more toxic to experimental animals than sterile tissue extracts. He also found that death of animals given injections of menstrual blood was due to bacteremia, an effect that could be prevented by giving antibiotics. Nor was he able to demonstrate a toxic substance in the premenstrual or menstrual endometrium. It might be mentioned in this connection that endometrial tissue destroyed by experimental ischemia in the experiments by Emmel, Worthington and Allen (1941), obviously did not influence menstruation nor did involuting endometrial tissue in uterine fistulae (p. 564). Therefore, the presence of a specific toxin that may induce menstruation has not been conclusively demonstrated.

Regardless of the specific cause of menstruation, the evidence shows that it can occur in the absence of coiled arteries, endometrial glands, or surface mucosa, and is unrelated to the thickness of the endometrium. This statement is based on conditions that have been experimentally induced in the monkey and they strongly indicate that menstruation, whatever the cause, is a stromal phenomenon. This view seems to be in agreement with the observations reported by Bartelmez in his elegant studies of the morphology of the endometrium of both monkeys and the human being. He emphasizes changes taking place in the connective tissue elements of the stroma and points out that much less tissue is lost at menstruation

than is commonly thought (Bartelmez, 1957). The reduction in thickness is due primarily to loss of ground substance from the stroma, and conversely, the outstanding feature of repair is the increase in stromal ground substance (Fig. 9.23). Mitoses are rarely seen in the stroma during repair and are not abundant enough in any phase according to Bartelmez to account for the observed increase in thickness of the endometrium. Our present knowledge indicates that an explanation of menstruation may be found in the metabolic effects induced in the stromal connective tissue of the endometrium by a sudden withdrawal of a supporting hormonal stimulus.

### XI. References

- ALLEN, E. 1927. The menstrual cycle in the monkey, *Macacus chusius*; observations on normal animals, the effects of removal of the ovaries and the effects of injections of ovarian and placental extracts into the spayed animals. *Contr. Embryol., Carnegie Inst. Washington*, **19**, 1-44.
- ALLEN, E. 1928. Further experiments with an ovarian hormone in the ovariectomized adult monkey, *Macacus chusius*, especially the degenerative phase of the experimental menstrual cycle. *Am. J. Anat.*, **42**, 467-487.
- ALLEN, E., DIDDLE, A. W., BURFORD, T. H., AND ELDER, J. H. 1936. Analyses of urine of the chimpanzee for estrogenic content during various stages of the menstrual cycle. *Endocrinology*, **20**, 546-549.
- ALLEN, E., PRATT, J. P., NEWELL, Q. C., AND BLAND, L. J. 1939. Human tubal ova; related early corpora lutea and uterine tubes. *Contr. Embryol., Carnegie Inst. Washington*, **22**, 45-76.
- BACHMAN, C., COLLIP, J. B., AND SELYE, H. 1935. The effects of prolonged oestriol administration upon the sex skin of *Macaca mulatta*. *Proc. Roy. Soc., London, ser. B.*, **117**, 16-21.
- BARTELMIZ, G. W. 1933. Histologic studies on the menstruating mucous membrane of the human uterus. *Contr. Embryol., Carnegie Inst. Washington*, **24**, 141-186.
- BARTELMIZ, G. W. 1937. Menstruation. *Physiol. Rev.*, **17**, 28-72.
- BARTELMIZ, G. W. 1951. Cyclic changes in the endometrium of the rhesus monkey (*Macacus mulatta*). *Contr. Embryol., Carnegie Inst. Washington*, **31**, 101-144.
- BARTELMIZ, G. W. 1957. The phases of the menstrual cycle and their interpretation in terms of the pregnancy cycle. *Am. J. Obst. & Gynec.*, **74**, 931-955.
- BRYANS, F. E. 1951. Progesterone of the blood in the menstrual cycle of the monkey. *Endocrinology*, **48**, 733-740.
- BUNTON, C. L. 1940. Pregnanediol determinations as an aid in clinical diagnosis. *Am. J. Obst. & Gynec.*, **40**, 202-211.
- COLLINGS, M. R. 1926. A study of the cutaneous reddening and swelling about the genitalia of the monkey, *Macacus chusius*. *Anat. Rec.*, **33**, 271-287.
- CORNER, G. W. 1923. Ovulation and menstruation in *Macacus chusius*. *Contr. Embryol., Carnegie Inst. Washington*, **15**, 73-101.
- CORNER, G. W. 1935. Influence of the ovarian hormones, estrin and progesterin, upon the menstrual cycle of the monkey. *Am. J. Physiol.*, **113**, 238-250.
- CORNER, G. W. 1937. Experimental menstruation. *Science*, **85**, 437-438.
- CORNER, G. W. 1942. The fate of the corpora lutea and the nature of the corpora aberrantia in the rhesus monkey. *Contr. Embryol., Carnegie Inst. Washington*, **30**, 87-96.
- CORNER, G. W. 1945. Development, organization and breakdown of the corpus luteum in the rhesus monkey. *Contr. Embryol., Carnegie Inst. Washington*, **31**, 119-146.
- CORNER, G. W. 1951. Our knowledge of the menstrual cycle, 1910-1950. *Lancet*, **1**, 919-923.
- CORNER, G. W., AND ALLEN, W. M. 1936. Inhibition of menstruation by crystalline progesterone. *Proc. Soc. Exper. Biol. & Med.*, **34**, 723-724.
- CROSSEN, R. J. 1953. *Diseases of Women*. St. Louis: C. V. Mosby Company.
- DAVIS, M. E., AND HARTMAN, C. G. 1935. Changes in vaginal epithelium during pregnancy in relation to the vaginal cycle. *J. A. M. A.*, **104**, 279-285.
- DICZFALUSY, E. 1953. Chorionic gonadotrophin and estrogens in the human placenta. *Acta endocrinol., Suppl.*, **12**, 87-167.
- DORFMAN, R. I. 1956. Metabolism of androgens, estrogens and corticoids. *Am. J. Med.*, **21**, 679-687.
- DORFMAN, R. I., AND VAN WAGENEN, G. 1941. The sex hormone excretion of adult female and pregnant monkeys. *Surg. Gynec. & Obst.*, **73**, 545-548.
- DUNCAN, P. A., ALLEN, E., AND HAMILTON, J. B. 1941. The action of testosterone propionate on experimental menstruation in the monkey. *Endocrinology*, **28**, 107-111.
- ECKSTEIN, P. 1950. The induction of progesterone withdrawal bleeding in spayed monkeys. *J. Endocrinol.*, **6**, 105-111.
- ECKSTEIN, P., AND ZUCKERMAN, S. 1956. In *Marshall's Physiology of Reproduction*, A. S. Parkes, Ed. Vol. 1, p. 334. London: Longmans Green & Company.
- EMMEL, V. M., WORTHINGTON, R. V., AND ALLEN, E. 1941. Attempts to induce menstruation by operative ischemia in monkeys. *Endocrinology*, **29**, 330-335.
- ENGLE, E. T. 1937. Problems of experimental menstruation. *Cold Spring Harbor Symposia Quant. Biol.*, **5**, 111-114.
- ENGLE, E. T., AND SMITH, P. E. 1935. Some uterine effects obtained in female monkeys during continued estrin administration, with especial

- reference to the cervix uteri. *Anat. Rec.*, **6**, 471-483.
- ENGLE, E. T., SMITH, P. E., AND SHIELESNYAK, M. C. 1935. The role of estrin and progesterin in experimental menstruation. *Am. J. Obst. & Gynec.*, **29**, 787-797.
- ENGLE, E. T., AND SMITH, P. E. 1938. The endometrium of the monkey and estrone-progesterone balance. *Am. J. Anat.*, **63**, 349-365.
- ENGLE, E. T., AND SMITH, P. E. 1939. Certain actions of testosterone on the endometrium of the monkey and on uterine bleeding. *Endocrinology*, **25**, 1-6.
- FISH, W. R., YOUNG, W. C., AND DORFMAN, R. I. 1941. Excretion of estrogenic and androgenic substances by female and male chimpanzees with known mating behavior records. *Endocrinology*, **28**, 585-592.
- FLUTHMANN, C. F. 1954. Comparative studies of squamous metaplasia of the cervix uteri and endometrium. *Am. J. Obst. & Gynec.*, **68**, 1447-1462.
- FORBES, T. R., HOOKER, C. W., AND PFEIFFER, C. A. 1950. Plasma progesterone levels and the menstrual cycle of the monkey. *Proc. Soc. Exper. Biol. & Med.*, **73**, 177-179.
- GILLMAN, J. 1937a. The cyclical changes in the vaginal smear in the baboon and its relationship to the perineal swelling. *South African J. M. Sc.*, **2**, 44-56.
- GILLMAN, J. 1937b. Experimental studies on the menstrual cycle of the baboon (*Papio porcarius*). *South African J. M. Sc.*, **2**, 156-166.
- GILLMAN, J. 1938. Experimental studies on the menstrual cycle of the baboon (*Papio porcarius*). *South African J. M. Sc.*, **3**, 66-71.
- GILLMAN, J. 1940a. Experimental studies on the menstrual cycle of the baboon (*Papio porcarius*). VI. The effect of progesterone upon the first part of the cycle in normal female baboons. *Endocrinology*, **26**, 80-87.
- GILLMAN, J. 1940b. The effect of multiple injections of progesterone on the turgescence perineum of the baboon (*Papio porcarius*). *Endocrinology*, **26**, 1072-1077.
- GILLMAN, J., AND GILBERT, C. 1946. The reproductive cycle of the chacma baboon (*Papio ursinus*) with special reference to the problems of menstrual irregularities as assessed by the behaviour of the sex skin. *South African J. M. Sc., Biol. Suppl.*, **11**, 1-54.
- GILLMAN, J., AND SMYTH, G. S. 1939. The hormonal content of the human luteal follicle of pregnancy as determined by its effect on the perineum of the baboon. *South African J. M. Sc.*, **4**, 36-45.
- HAMAN, J. O. 1942. The length of the menstrual cycle. A study of 150 normal women. *Am. J. Obst. & Gynec.*, **43**, 870-873.
- HAMLEN, E. C., CUYLER, W. K., POWELL, N. B., ASHLEY, C., AND BAPTIST, M. 1939. Some clinical observations upon the metabolism and utilization of crystalline progesterone. *Endocrinology*, **25**, 13-16.
- HAMILTON, C. E. 1949. Observations on the cervical mucosa of the Rhesus monkey. *Contr. Embryol.*, Carnegie Inst. Washington, **33**, 81-101.
- HARTMAN, C. G. 1929. Three types of uterine bleeding in the monkey and the homology of menstruation (Abstr.). *Anat. Rec.*, **42**, 19.
- HARTMAN, C. G. 1932. Studies in the reproduction of the monkey, *Macacus (Pithecus) rhesus*, with special reference to menstruation and pregnancy. *Contr. Embryol.*, Carnegie Inst. Washington, **23**, 1-16.
- HARTMAN, C. G. 1934. Some attempts to influence the menstrual cycle in the monkey. *Am. J. Obst. & Gynec.*, **27**, 564-570.
- HARTMAN, C. G. 1937. Menstruation inhibiting action of testosterone. *Proc. Soc. Exper. Biol. & Med.*, **37**, 87-89.
- HARTMAN, C. G. 1944. Regeneration of the monkey uterus after surgical removal of the endometrium and accidental endometriosis. *Western J. Surg. Obst. & Gynec.*, **52**, 87-102.
- HARTMAN, C. G., AND SPEERT, H. 1941. Action of progesterone on the genital organs of the unprimed Rhesus monkey. *Endocrinology*, **29**, 639-648.
- HARTMAN, C. G., GESCHICKTER, G. F., AND SPEERT, H. 1941. Effects of continuous estrogen administration in very large doses. *Anat. Rec., Suppl.*, **2**, 79, 31.
- HELLMAN, L. M., ROSENTHAL, A. H., KISTNER, R. W., AND GORDON, R. 1954. Some factors influencing the proliferation of the reserve cells in the human cervix. *Am. J. Obst. & Gynec.*, **67**, 899-915.
- HERTIG, A. T., AND ROCK, J. 1944. On the development of the early human ovum, with special reference to the trophoblast of the previllous stage; a description of 7 normal and 5 pathological human ova. *Am. J. Obst. & Gynec.*, **47**, 149-184.
- HEUSER, C. H., AND STREETER, G. L. 1941. Development of the macaque embryo. *Contr. Embryol.*, Carnegie Inst. Washington, **29**, 17-55.
- HISAW, F. L. 1935. The physiology of menstruation in *Macacus rhesus* monkeys. *Am. J. Obst. & Gynec.*, **29**, 638-659.
- HISAW, F. L. 1942. The interaction of the ovarian hormones in experimental menstruation. *Endocrinology*, **30**, 301-308.
- HISAW, F. L. 1943. Androgens and experimental menstruation in the monkey (*Macaca mulatta*). *Endocrinology*, **33**, 39-47.
- HISAW, F. L. 1950. Factors influencing endometrial growth in monkeys (*Macaca mulatta*). In *A Symposium on Steroid Hormones*, E. S. Gordon, Ed., pp. 259-276. Madison: University of Wisconsin Press.
- HISAW, F. L. 1959. Endocrine adaptations of the mammalian estrous cycle and gestation. In *Columbia University Symposium on Comparative Endocrinology*, pp. 533-552.
- HISAW, F. L., GREEP, R. O., AND FEVOLD, H. I. 1937. Effects of progesterone on the female genital tract after castration atrophy. *Proc. Soc. Exper. Biol. & Med.*, **36**, 840-842.
- HISAW, F. L., AND GREEP, R. O. 1938. The inhibition of uterine bleeding with oestradiol and

- progesterone and associated endometrial modifications. *Endocrinology*, **23**, 1-14.
- HISAW, F. L., AND HISAW, F. L., JR. 1958. Spontaneous carcinoma of the cervix uteri in a monkey (*Macaca mulatta*). *Cancer*, **11**, 810-816.
- HISAW, F. L., AND LENDRUM, F. C. 1936. Squamous metaplasia in the cervical glands of the monkey following oestrin administration. *Endocrinology*, **20**, 228-229.
- HISAW, F. L., MEYER, R. K., AND FEVOLD, H. L. 1930. Production of a premenstrual endometrium in castrated monkeys by ovarian hormones. *Proc. Soc. Exper. Biol. & Med.*, **27**, 400-403.
- HITSCHMANN, F., AND ADLER, L. 1907. Die Lehre von der Endometritis. *Zschr. Geburtsh. u. Gynäk.*, **60**, 63-86.
- KAISER, I. H. 1947. Absence of coiled arterioles in the endometrium of menstruating New World monkeys. *Anat. Rec.*, **99**, 353-363.
- KATFMANN, C., WESTPHAL, U., AND ZANDER, J. 1951. Untersuchungen über die biologische Bedeutung der Ausscheidungsprodukte des Gelbkörperhormons. *Arch. Gynäk.*, **179**, 247-299.
- KNAUS, H. 1950. *Die Physiologie der Zeugung des Menschen*. Wien: Wilhelm Maudrich.
- KROHN, P. L. 1951. The induction of menstrual bleeding in amenorrhoeic and normal monkeys by progesterone. *J. Endocrinol.*, **7**, 310-317.
- KROHN, P. L. 1955. The induction of cyclic uterine bleeding in normal and spayed rhesus monkeys by progesterone. *J. Endocrinol.*, **12**, 69-85.
- KROHN, P. L., AND ZUCKERMAN, S. 1937. Water metabolism in relation to the menstrual cycle. *J. Physiol.*, **88**, 369-387.
- LATZ, L. J., AND REISER, E. 1942. Further studies on the sterile and fertile periods in women. *Am. J. Obst. & Gynec.*, **43**, 74-79.
- LENDRUM, F. C., AND HISAW, F. L. 1936. Cytology of the monkey endometrium under influence of follicular and corpus luteum hormones. *Proc. Soc. Exper. Biol. & Med.*, **34**, 394-396.
- LÓPEZ COLUMBO DE ALLENDE, I., AND ORÍAS, O. 1950. *Cytology of the Human Vagina*. New York: Paul B. Hoeber, Inc.
- LÓPEZ COLUMBO DE ALLENDE, I., SHORR, E., AND HARTMAN, C. G. 1945. A comparative study of the vaginal smear cycle of the rhesus monkey and the human. *Contr. Embryol.*, Carnegie Inst. Washington, **31**, 1-26.
- MARKEE, J. E. 1949. Menstruation in intraocular endometrial transplants in the rhesus monkey. *Contr. Embryol.*, Carnegie Inst. Washington, **23**, 219-308.
- MARKEE, J. E. 1946. Morphologic and endocrine basis for menstrual bleeding. In *Progress in Gynecology*, Meigs and Sturgis, Eds. Vol. II, pp. 37-47. New York: Grune and Stratton.
- MARKEE, J. E., AND BERG, B. 1944. Cyclic fluctuations in blood estrogen as a possible cause of menstruation. *Stanford Med. Bull.*, **2**, 55-60.
- MARKEE, J. E., DAVIS, J. H., AND HINSEY, J. C. 1936. Uterine bleeding in spinal monkeys. *Anat. Rec.*, **64**, 231-245.
- MAZER, C., AND ISRAEL, S. L. 1951. *Diagnosis and Treatment of Menstrual Disorders and Sterility*. New York: Paul B. Hoeber, Inc.
- MEYER, R. 1911. Über Corpus luteum-Bildung beim Menschen. *Arch. Gynäk.*, **93**, 354-404.
- NISSEN, H. W., AND YERKES, R. M. 1943. Reproduction in the chimpanzee: report on 49 births. *Anat. Rec.*, **86**, 567-578.
- NOVAK, E., AND TE LINDE, R. W. 1924. Endometrium of menstruating uterus. *J. A. M. A.*, **83**, 900-906.
- OVERHOLSER, M. D., AND ALLEN, E. 1933. Ovarian hormone and traumatic stimulation of monkey's cervix to a condition resembling early cancer. *Proc. Soc. Exper. Biol. & Med.*, **30**, 1322-1326.
- OVERHOLSER, M. D., AND ALLEN, E. 1935. Atypical growth induced in cervical epithelium of monkey by prolonged injections of ovarian hormone combined with chronic trauma. *Surg. Gynec. & Obst.*, **60**, 129-136.
- OVERHOLSER, M. D., AND NELSON, W. O. 1936. Migration of nuclei in uterine epithelium. A monkey following prolonged oestrin injections. *Proc. Soc. Exper. Biol. & Med.*, **34**, 839-841.
- PAPANICOLAOU, G. N., TRAUT, H. F., AND MARCHETTI, A. A. 1948. *The Epithelia of Woman's Reproductive Organs*. New York: Commonwealth Fund.
- PARKES, A. S., AND ZUCKERMAN, S. 1931. The menstrual cycle of the Primates. II. Some effects of oestrin on baboons and macaques. *J. Anat.*, **65**, 272-276.
- PHELPS, D. 1946. Endometrial vascular reactions and the mechanism of nidation. *Am. J. Anat.*, **79**, 167-197.
- PHELPS, D. H. 1947. The factor of previous treatment in experimental menstruation. *J. Clin. Endocrinol.*, **7**, 611-623.
- RAKOFF, A. E. 1946. Studies on high dosage progesterone therapy of amenorrhoea. *Am. J. Obst. & Gynec.*, **51**, 480-491.
- ROCK, J., AND HERTIG, A. 1942. Some aspects of early human development. *Am. J. Obst. & Gynec.*, **44**, 973-983.
- ROSSMAN, I. 1940. The decidual reaction in the rhesus monkey (*Macaca mulatta*). I. The epithelial proliferation. *Am. J. Anat.*, **66**, 277-365.
- SCHRÖDER, R. 1914. Über das Verhalten der Uterusschleimhaut um die Zeit der Menstruation. *Monatsschr. Geburtsh. u. Gynäk.*, **39**, 3-21.
- SEEGAR, E. G. 1940. The histologic effect of progesterone on hyperplastic endometria. *Am. J. Obst. & Gynec.*, **39**, 469-476.
- SMITH, O. W., AND SMITH, G. V. 1951. Endocrinology and related phenomena of the human menstrual cycle. *Recent Progr. Hormone Res.*, **7**, 209-253.
- SOMMERVILLE, I. F., AND MARRIAN, G. F. 1950. Urinary excretion of pregnadiol in human subjects following the administration of progesterone and of pregnane-3 $\alpha$ :20 $\alpha$ -diol. *Biochem. J.*, **46**, 285-289.
- STIEVE, H. 1926. Die regelmässigen Veränderungen der Muskulatur und des Bindegewebes in



- der menschlichen Gebärmutter in ihrer Abhängigkeit von der Follikelreife und der Ausbildung eines gelben Körpers, nebst Beschreibung eines menschlichen Eies im Zustand der ersten Reifeteilung. *Ztschr. mikroskop.-anat. Forsch.*, **6**, 351-397.
- STIEVE, H. 1942. Der Einfluss von Angst und psychischer Erregung auf Bau und Funktion der weiblichen Geschlechtsorgane. *Zentralbl. Gynäk.*, **66**, 1698-1708.
- STIEVE, H. 1943. Weitere Tatsachen zur Klärung der Frage: Wann wird das Ei aus dem Eierstock ausgestossen? *Zentralbl. Gynäk.*, **67**, 58-77.
- STIEVE, H. 1944. Paracyclische Ovulationen. *Zentralbl. Gynäk.*, **68**, 257-272.
- STURGIS, S. H. 1942. Method for obtaining uterine fluid from the monkey: effect of pilocarpine, atropine, physiologic salt solution and adrenalin. *Endocrinology*, **31**, 664-672.
- VAN DYKE, H. B., AND CH'EN, G. 1936. Observations on biochemistry of genital tract of female macaque particularly during menstrual cycle. *Am. J. Anat.*, **58**, 473-499.
- VAN WAGENEN, G. 1945. Mating in relation to pregnancy in the monkey. *Yale J. Biol. & Med.*, **17**, 745-760.
- VAN WAGENEN, G. 1947. Early mating and pregnancy in the monkey. *Endocrinology*, **40**, 37-43.
- VAN WAGENEN, G., AND MORSE, A. H. 1940. Cyclic changes in the exteriorized uterus. *Endocrinology*, **27**, 268-273.
- VENNING, E. H., AND BROWNE, J. S. L. 1937. Studies on corpus luteum function. I. The urinary excretion of sodium pregnandiol glucuronidate in the human menstrual cycle. *Endocrinology*, **21**, 711-721.
- WERNER, A. A., AND COLLIER, W. D. 1933. The effect of theelin injections on the castrated woman. *J. A. M. A.*, **100**, 633-640.
- WESTMAN, A. 1932. Studien über den Sexualzyklus bei Makakus-Rhesus-Affen, nebst einigen Bemerkungen über den menstruellen Blutungs-mechanismus. *Acta obst. et gynec. scandinav.*, **12**, 282-328.
- WISLOCKI, G. B., AND STREETER, G. L. 1938. On the placentation of the macaque (*Macaca mulatta*), from the time of implantation until the formation of the definitive placenta. *Contr. Embryol.*, Carnegie Inst. Washington, **27**, 1-66.
- YOUNG, W. C., AND YERKES, R. M. 1943. Factors influencing the reproductive cycle in the chimpanzee: the period of adolescent sterility and related problems. *Endocrinology*, **33**, 121-154.
- ZARROW, M. X., HISAW, F. L., AND BRYANS, F. 1950. Conversion of desoxyprogesterone acetate to progesterone *in vivo*. *Endocrinology*, **46**, 403-404.
- ZARROW, M. X., SHOGER, R. L., AND LAZO-WASEM, E. A. 1954. The rate of disappearance of exogenous progesterone from the blood. *J. Clin. Endocrinol.*, **14**, 645-652.
- ZONDEK, B. 1953. Does menstrual blood contain a specific toxin? *Am. J. Obst. & Gynec.*, **65**, 1065-1068.
- ZONDEK, B. 1954. On the mechanism of uterine bleeding. *Am. J. Obst. & Gynec.*, **68**, 310-314.
- ZONDEK, B., AND ROZIN, S. 1938. Production of uterine haemorrhage in the normal cycle and in amenorrhoea through progesterone. *J. Obst. & Gynaec. Brit. Emp.*, **45**, 918-931.
- ZUCKERMAN, S. 1930. The menstrual cycle of the Primates. I. General nature and homology. *Proc. Zool. Soc., London*, **1930**, 691-754.
- ZUCKERMAN, S. 1935. The menstrual cycles in the Primates. VIII. The estrin-withdrawal theory of menstruation. IX. The effect of estrin on the denervated sexual skin. *Proc. Roy. Soc., London, ser. B.*, **118**, 13-33.
- ZUCKERMAN, S. 1936a. Inhibition and induction of uterine bleeding by means of estrone. *Lancet*, **2**, 9-13.
- ZUCKERMAN, S. 1936b. The interrelation of estrone and progesterin in the menstrual cycle. *J. Physiol.*, **86**, 31-33.
- ZUCKERMAN, S. 1937a. The duration and phases of the menstrual cycle in Primates. *Proc. Zool. Soc., London, ser. A.*, **1937**, 315-329.
- ZUCKERMAN, S. 1937b. The menstrual cycle of the Primates. X. The oestrone threshold of the uterus of the rhesus monkey. XI. The part played by oestrogenic hormone in the menstrual cycle. *Proc. Roy. Soc., London, ser. B.*, **123**, 441-471.
- ZUCKERMAN, S. 1937c. Effects of prolonged oestrin-stimulation on the cervix uteri. *Lancet*, **1**, 435-437.
- ZUCKERMAN, S. 1937d. Further observations on endocrine interaction in the menstrual cycle. *J. Physiol.*, **89**, 49-51.
- ZUCKERMAN, S. 1937e. The duration and phases of the menstrual cycle in Primates. *Proc. Zool. Soc. London, ser. A.*, **1937**, 315-329.
- ZUCKERMAN, S. 1939. The effect of sex hormones, cortin, and vasopressin on water-retention in the reproductive organs of monkeys. *J. Endocrinol.*, **1**, 147-155.
- ZUCKERMAN, S. 1941. Periodic uterine bleeding in spayed rhesus monkeys injected daily with constant threshold dose of oestrone. *J. Endocrinol.*, **2**, 263-267.
- ZUCKERMAN, S. 1949. The menstrual cycle. *Lancet*, **2**, 176.
- ZUCKERMAN, S. 1951. The hormonal basis of uterine bleeding. *Acta endocrinol.*, **7**, 378-388.
- ZUCKERMAN, S., AND PARKES, A. S. 1932. The menstrual cycle of the primates. V. The cycle of the baboon. *Proc. Zool. Soc., London*, **1932**, 139-191.
- ZUCKERMAN, S., VAN WAGENEN, G., AND GARDINER, R. H. 1938. The sexual skin of the rhesus monkey. *Proc. Zool. Soc., London, ser. A.*, **103**, 385-401.

# 10

## THE MAMMARY GLAND AND LACTATION

*A. T. Cowie and S. J. Folley*

NATIONAL INSTITUTE FOR RESEARCH IN DAIRYING, SHINFIELD,  
READING, ENGLAND

### I. Introduction

I. INTRODUCTION	590
II. DEVELOPMENT OF THE MAMMARY GLAND	591
A. Histogenesis	591
B. Normal Postnatal Development	593
1. Methods of assessing mammary development	593
2. Mammary development in the nonpregnant female	594
3. Mammary growth in the male	595
4. Mammary development during pregnancy	596
5. Mammary involution	598
C. Experimental Analysis of Hormonal Influences	598
1. Ovarian hormones in the animal with intact pituitary	598
2. Anterior pituitary hormones	601
3. Metabolic hormones (corticoids, insulin, and thyroid hormones)	604
III. ENDOCRINE INFLUENCES IN MILK SECRETION	606
A. Anterior Pituitary Hormones	606
1. Initiation of secretion (lactogenesis)	606
2. Maintenance of milk secretion—galactopoiesis	609
3. Suckling stimulus and the maintenance of lactation	611
B. Hormones of the Adrenal Cortex	612
C. Ovarian Hormones	613
D. Thyroid Hormones	617
E. Parathyroid Hormone	618
F. Insulin	619
IV. REMOVAL OF MILK FROM THE MAMMARY GLANDS: PHYSIOLOGY OF SUCKLING AND MILKING	619
A. Milk-Ejection Reflex	619
B. Role of the Neurohypophysis	621
C. Milk-Ejection Hormone	622
D. Effector Contractile Mechanism of the Mammary Gland	623
E. Inhibition of Milk Ejection	624
F. Neural Pathways of the Milk-Ejection Reflex	625
G. Mechanism of Suckling	626
V. RELATION BETWEEN THE REFLEXES CONCERNED IN THE MAINTENANCE OF MILK SECRETION AND MILK EJECTION	627
VI. PHARMACOLOGIC BLOCKADE OF THE REFLEXES CONCERNED IN THE MAINTENANCE OF MILK SECRETION AND MILK EJECTION	630
VII. CONCLUSION	632
VIII. REFERENCES	632

This account of the hormonal control of the mammary gland is in no way intended as an exhaustive treatment of mammary gland physiology, but rather an attempted synthesis of current knowledge which it is hoped will be of interest as an exposition of the authors' conception of the present status of the subject. Since the publication of the second edition of this book, the emphasis in the field under review has tended to shift towards the development of quantitative techniques for assessing the degree of mammary development, towards attempts at a penetration into the interactions of hormones with the biochemical mechanisms of the mammary epithelial cells, and towards an increasing preoccupation with the interplay of nervous and endocrine influences in certain phases of lactation. The reader's acquaintance with the classical foundations of the subject as described in the second edition of this book (Turner, 1939) and in other subsequent reviews (Folley, 1940; Petersen, 1944, 1948; Folley and Malpress, 1948a, b; Mayer and Klein, 1948, 1949; Folley, 1952a, 1956; Dabelow, 1957) will

therefore be assumed and used as a point of departure for the present account which can most profitably be concerned mainly with developments which have occurred since the last edition was published. Reference will frequently be made to these reviews in which authority will be found for the many *ex cathedra* statements that will be made, but original sources will be cited wherever appropriate.<sup>1</sup>

As an aid to logical treatment of the subject the scheme of classification proposed by Cowie, Folley, Cross, Harris, Jacobsohn and Richardson (1951) will be followed in this chapter. Besides introducing a system of terminology in respect of the physiology of suckling or milking, these writers have put forward a classification scheme which is an extension of one previously proposed by one of the present authors (Folley, 1947). This scheme considers the phenomenon of lactation as divisible into a number of phases as follows:

		Milk synthesis
Lactation	Milk secretion	Passage of milk from the alveolar cells
		Passive withdrawal of milk
	Milk removal	The milk-ejection reflex

As is logical and customary, discussion of lactation itself will be preceded by consideration of mammary development.

## II. Development of the Mammary Gland

### A. HISTOGENESIS

References to the earlier work on the histogenesis of the mammary gland in various species will be found in Turner (1939,

<sup>1</sup>Within the last 10 years there have been several symposia devoted to the problems of the physiology of lactation. The proceedings of these symposia have been published: *Mécanisme physiologique de la sécrétion lactée*, Strasbourg, 1950; *Colloques Internationaux du Centre National de la Recherche Scientifique*, XXXII, 1951, Paris; *Symposium sur la physiologie de la lactation*, Montreal, 1953, *Rev. Canad. Biol.*, **13**, No. 4, 1954; *Symposium sur la physiologie de la lactation*, Brussels, 1956, *Ann. endocrinol.* **17**, 519; *A Discussion on the Physiology and Biochemistry of Lactation*, London, 1958, *Proc. Roy. Soc., ser. B.* **149**, 301.

1952) and Folley (1952a). There have also been studies on the opossum (Plagge, 1942), the mouse and certain wild rodents (Raynaud, 1949b), the rhesus monkey (Speert, 1948), and man (Williams and Stewart, 1945; Thölen, 1949; Hughes, 1950).

A question which in the last decade has been receiving attention is whether the prenatal differentiation and development of the mammary primordium is hormonally controlled. According to Balinsky (1950a, b), the mitotic index of the mammary bud in the embryo of the mouse and rabbit is lower than that of the surrounding epidermis and he concludes that differentiation of the bud is due not to cellular proliferation (growth) but to a process of aggregation ("morphogenetic movement") of epidermal cells. This author also reports that for some time after its formation, the mammary bud is quiescent as regards growth, thus exhibiting negative allometry compared with the whole embryo, until the sprouting of the primary duct initiates a phase of positive allometry. The question is, what is the stimulus responsible for the onset of this allometric phase? Is the growth and ramification of the duct primordium, like that of the adult duct system, due to the action of estrogen emanating from the fetal gonad or from the mother?

Hardy (1950) has shown that differentiation and growth of the mammary bud of the mouse could proceed in explants from the ventral body wall of the embryo, cultured *in vitro*, even when no primordia were present at the time of explantation (10-day embryo). Primary and then secondary mammary ducts and a streak canal differentiated and a developmental stage similar to that in the 7-day-old mouse could be reached. Balinsky (1950b) was also able to observe the formation and growth of mammary buds in approximately their normal locations in a minority of cases in which body-wall explants of 10-day mouse embryos were cultivated *in vitro*. Discounting the rather remote possibility that the effects were due to minute amounts of sex hormones present in the culture media, these observations indicate that hormonal influences are not necessary for the prenatal stages of mammary development, and in accord with

this Balinsky (1950b) found that addition of estrogens or mouse pituitary extract to the culture medium had no effect on the growth of the mammary rudiment *in vitro*.

On the other hand, extensive studies by Raynaud (1947c, 1949b) of the sex difference in the histogenesis of the mammary gland in the mouse, first described by Turner and Gomez (1933), indicate that the mammary rudiment is sensitive to the influence of exogenous gonadal steroids during the prenatal stages. The mammary bud in the strain of mouse studied by Raynaud shows no sex differences in development until the 15th to 16th day at which time the genital tract, hitherto indifferent, begins to differentiate. Coincident with this the mammary bud in the male becomes surrounded by a condensation of special mesenchymal cells the action of which constricts the bud at its junction with the epidermis from which it ultimately becomes completely detached (Fig. 10.1). The inguinal glands seem particularly susceptible to this influence because they exhibit this effect earlier than the thoracic glands and in some strains the second inguinal bud in the male tends to disappear completely. Sex differences in the prenatal development of the mammary rudiment in certain species of wild mouse were also described by Raynaud (1949b).

The fact that, after x-ray destruction of the gonad in the 13-day male mouse embryo, the mammary bud remains attached to the epidermis and the duct primordia ramify in a manner similar to the primordia in the female shows that this phenomenon of detachment of the mammary bud is due to the action of the fetal testis (Raynaud and Frilley, 1947, 1949). That the masculinizing action of the fetal testis seems to be due to the hormonal secretion of a substance having the same effect as testosterone is suggested by the fact that injection of testosterone into the pregnant mother causes the mammary buds in the female embryo to undergo the male type of development (Fig. 10.1). Here again the inguinal glands seem most sensitive because sufficiently high doses in many cases cause complete disappearance of the primordia of the second inguinal glands (Raynaud, 1947a, 1949a).

On the other hand, destruction of the fetal gonad in the female has no effect on the development of the mammary bud (Raynaud and Frilley, 1947, 1949), yet the latter is not completely indifferent to the action of estrogen because high doses of estrogen administered to the mother, or lower doses injected early into the embryo itself inhibit the growth of the mammary bud (Raynaud, 1947b, 1952; Raynaud and Raynaud, 1956, 1957), an effect reminiscent of the well known action of excessive doses of estrogen on the adult mammary duct system (for reference see Folley, 1952a). In pouch young of the opossum, on the other hand, Plagge (1942) found that estrogen treatment stimulated growth of the mammary duct primordia. Similarly in the fetal male mouse low doses of estrogen stimulate growth of the mammary bud (Raynaud, 1947d), but this may be an indirect effect ascribable to estrogen's antagonizing the inhibitory action of the fetal testis.

The problem of the histogenesis of the teat has also come under experimental attack. Raynaud and Frilley (1949) showed that the formation of the "epithelial hood," the circular invagination of the epidermis surrounding the mammary bud which constitutes the teat anlage in the mouse, is not hormonally determined since its appearance was not prevented by the irradiation of the fetal ovary at the 13th day of life. In the male mouse the epithelial hood does not normally appear and the male is born without teats. This is undoubtedly due to the action of the fetal testis inasmuch as the teat anlagen develop in the male embryos whose testes are irradiated at 13 days (Raynaud and Frilley, 1949).

The foregoing observations point to an abnormal type of development for the teat and mammary bud in the female fetus, at least in the mouse, although the mammary bud is specifically susceptible to the action of excess exogenous estrogen which can inhibit its development without affecting that of other skin gland primordia. The mammary bud is also susceptible to the action of androgen which in the normal male fetus not only directs its development along characteristic lines, but also suppresses the formation of the teat.

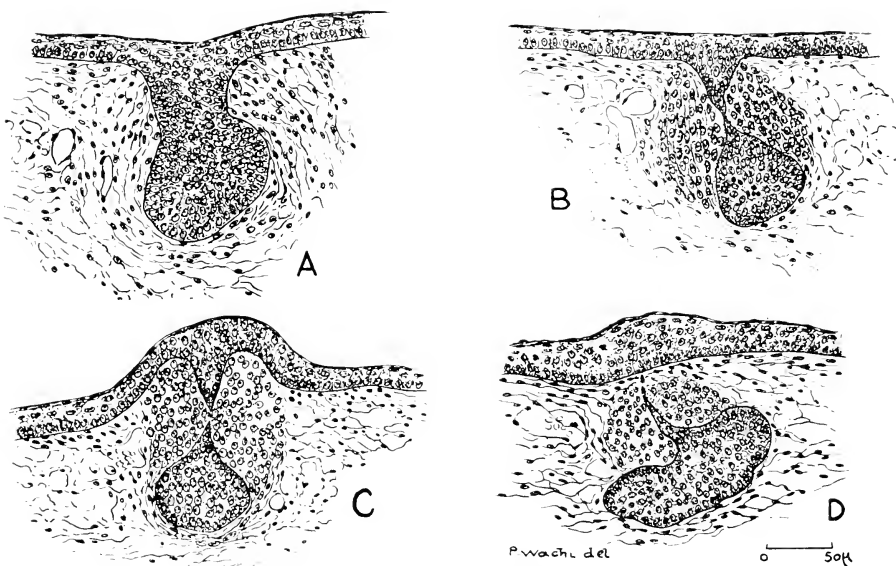

FIG. 10.1. Sex difference in the development of the mammary bud of the fetal mouse and effect of androgen on the histogenesis of the female mammary bud. A. First inguinal gland of female fetus (15 days, 17 hours). B. First inguinal gland of male fetus (15 days, 17 hours). C. Second inguinal gland of female fetus (15 days, 16 hours) from a mother receiving testosterone propionate. D. First inguinal gland of female fetus from the same litter as that in C. (From A. Raynaud, *Ann. endocrinol.*, **8**, 248-253, 1947.)

For further information on the morphogenesis of the mammary gland, the reader is referred to the recent detailed accounts by Dabelow (1957) and Raynaud (1960).

## B. NORMAL POSTNATAL DEVELOPMENT

### 1. Methods of Assessing Mammary Development

In the last two decades the increasing availability of the ovarian hormones in pure form and the prospect of the large scale practical application of fundamental knowledge of the hormonal control of the mammary gland to the artificial stimulation of udder growth and lactation in the cow, have together effected a demand for greater accuracy in studying and assessing the degree of mammary development. Various quantitative and objective procedures have now been evolved which allow results of developmental studies to be subjected to statistical investigation. These methods have been re-

viewed recently (Folley, 1956) and we need but mention them briefly.

In those species in which, save in late pregnancy, the mammae are more or less flat sheets of tissue, the classical whole-mount preparations have been the basis for several quantitative studies. From such preparations the area covered by the duct systems can be measured by suitable means (*e.g.*, as in our studies on the rat mammary gland; Cowie and Folley, 1947d), thus providing an accurate measure of duct extension. Such measurements, however, give no information on the morphologic changes within this area and so a semiquantitative scoring system to assess the degree of duct complexity has been used in conjunction with the measurements of area (see Cowie and Folley, 1947d). More reliable and objective techniques for measuring duct complexity were later developed in our laboratory by Silver (1953a) and Flux (1954a). Species such as the guinea pig in which the gland,

even when immature, is three-dimensional demand other methods. For such cases a precise but rather tedious method has been described by Benson, Cowie, Cox and Goldzweig (1957) which involves the determination of the volume of glandular tissue from area measurements of serial sections of the gland in conjunction with semiquantitative scoring procedures for assessing the morphologic characteristics of the tissue.

Particularly applicable to the lactating gland is the procedure developed by Richardson (see Cowie, Folley, Malpress and Richardson, 1952; Richardson, 1953) for assessing the total internal surface area of the mammary alveoli. It is of interest to note in passing that this technique is based on that developed by Short (1950) for measuring the surface area of the alveoli in the lung, the similarity in the geometry of the two organs allowing ready transference of the method from one to the other.

At present these quantitative procedures have the disadvantage of being slow and time consuming, and it seems likely that their further development will involve the use of electronic scanning methods to speed up the examination of the tissues. Of recent introduction are some biochemical procedures for assessing changes in mammary development. The desoxyribonucleic acid (DNA) content of any particular type of cell is said to be remarkably constant (see Vendrely, 1955, for review) and the amount of DNA in a tissue has been used as a reference standard directly related to the number of cells present in a tissue and to provide an estimate of the number of cells formed during the developmental phases of a gland or tissue (see Leslie, 1955, for review). Studies on DNA changes which occur in the mammary gland during pregnancy and lactation have been made in the rat by Kirkham and Turner (1953), Greenbaum and Slater (1957a), Griffith and Turner (1957), and Shimizu (1957). It should be noted, however, that some authorities have doubts as to the constancy under all conditions of the DNA content of a cell (see Brachot, 1957) and results obtained by this technique should be interpreted with some caution (see also Griffith and Turner, 1957). Other chemical methods for assessing mammary development include (a) the determination

of the iron content of the gland, based on the observation that iron retention occurs in the epithelium of the mammary glands of mice (Rawlinson and Pierce, 1950); (b) whole-mount autoradiographs using  $P^{32}$  (Lundahl, Meites and Wolterink, 1950); and (c) determination of the total content of alkaline phosphatase in the mammary gland (Huggins and Mainzer, 1957, 1958).

In view of the relative rapidity of the biochemical methods it seems likely that they will be used increasingly in the future.

A technique of clinical interest allowing the qualitative assessment of changes in mammary structure in the breast of pregnant and lactating women is the radiographic method described by Ingleby, Moore and Gershon-Cohen (1957).

To those seeking information of the microscopic anatomy of the human mammary gland we would recommend the excellent and beautifully illustrated review by Dablow (1957), and new facts on the cytologic changes occurring during milk secretion will be found in the electron microscopic study of the rat mammary gland by Bargmann and Knoop (1959), and of the mouse mammary gland by Holthmann (1959).

Having briefly outlined the various quantitative methods of assessing mammary development we will now consider recent studies on normal mammary growth.

## *2. Mammary Development in the Nonpregnant Female*

It has been the general belief that until puberty the mammary ducts show little growth, but more precise studies in which the rate of increase in mammary gland area has been related to the increase in body size have now shown that in the monkey, rat, and mouse a phase of rapid duct growth is initiated before puberty.

The first use of this procedure, relative growth analysis (for terminology see Huxley and Teissier, 1936), for the quantitative investigation of mammary duct growth was made by Folley, Guthkeleh and Zuckerman (1939), who showed that over a wide range of body weights, the breast in the nonpregnant female rhesus monkey grows faster than the body as a whole. Subsequently, more detailed studies of the dynamics of mammary growth using relative growth

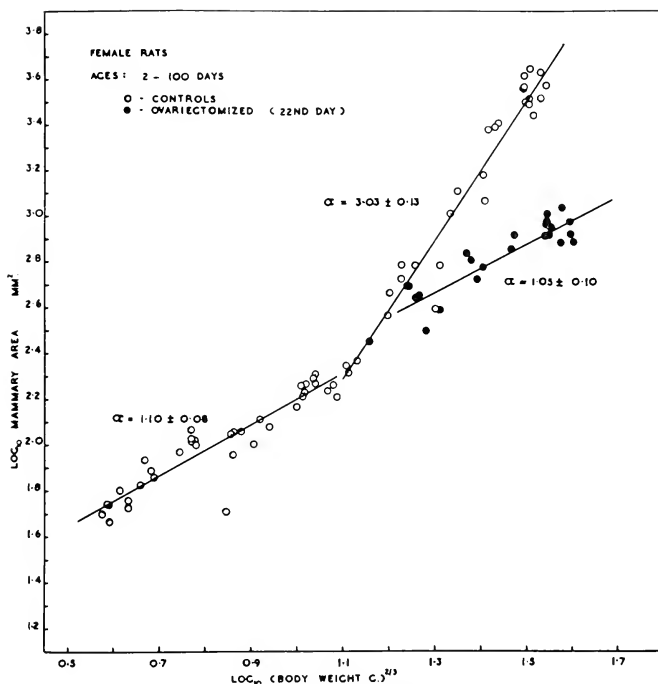

FIG. 10.2. Relative mammary gland growth in the female hooded Norway rat. (From A. T. Cowie, *J. Endocrinol.*, **6**, 145-157, 1949.)

analysis were made in the rat by Cowie (1949) and Silver (1953a, b) and in the mouse by Flux (1954a, b), and their results will now be summarized. In the rat the total mammary area increased isometrically with the body surface ( $\alpha = 1.1$ ) as compared with the theoretic value of 1.0) until the 21st to 23rd day when a phase of allometry ( $\alpha = 3.0$ ) set in. The onset of the allometric phase could be prevented by ovariectomy on the 22nd day (see Fig. 10.2). Since estrous cycles do not begin until the 35th to 42nd day in this strain of rat, it is clear that the rapid extension of the mammary ducts began well before puberty. In the immature male rat the increase of mammary area on body surface was slightly but significantly allometric; this was not altered by castration at the 22nd day. Earlier ovariectomy, *i.e.*, when the pups were 10 days old, was followed by a phase of slightly allometric growth of the mammary glands in the fe-

males ( $\alpha = 1.5$ ). With regard to the female mouse (CHI strain) a phase of marked allometry in mammary duct growth set in about the 24th day ( $\alpha = 5.2$ ) which could also be prevented by prior ovariectomy.

It is clear that the presence of the ovary is essential for the change from isometry to allometry, but the nature of the mechanisms governing the change is still uncertain (for further discussion, see Folley, 1956).

### 3. Mammary Growth in the Male

The testes have apparently little effect on mammary duct extension in the rat inasmuch as the gland in the male grows isometrically or nearly so and its specific growth rate is unaffected by castration. Castration at 21 days, however, does prevent for a time development of the lobules of acini, first described by Turner and Scholtze (1931), which are characteristic of the mammary gland in the male rat. Eventually,

however, some alveoli do develop in the mammary of immaturely castrated male rats (Cowie and Folley, 1947d; Cowie, 1949; Abrén and Etienne, 1957) and it has been postulated that these arise from the enhanced production by the adrenal cortex of mammogenic steroids (androgens or progesterone) due to the hormone imbalance brought about by gonadectomy (see Folley, 1956).

In a recent study, Abrén and Etienne (1957) have shown that the ducts and alveoli in the mammary gland of the male rat are remarkable in that their epithelial lining is unusually thick, being composed of several layers of cells. It had been previously noted by van Wagenen and Folley (1939) and Folley, Guthkeleh and Zuckerman (1939) that testosterone caused a thickening of the mammary duct epithelium in the monkey and sometimes papillomatous outgrowths of epithelium into the lumen of the duct. It would thus seem that, although the hormone of the testis is capable of eliciting alveolar development, these alveoli and ducts differ from those occurring in the female in the nature of their epithelium. It was further observed by Abrén and Etienne (1957) that in the castrated male rat the alveoli, which eventually developed, had a simple epithelial lining somewhat similar to that seen in the normal female rat, suggesting that, if the adrenals are responsible, the mammogenic steroid is more likely to be progesterone than an androgen.

A study of considerable clinical interest is that of Pfaltz (1949) on the developmental changes in the mammary gland in the human male. The greatest development reached was at the 20th year; by the 40th year there occurred an atrophy first of the parenchyma and later of the connective tissue. In the second half of the fifth decade there was renewed growth of the parenchyma and connective tissues. The hormonal background of these changes and the possible relationship with prostatic hypertrophy are discussed by Pfaltz. (Further details of the microscopic anatomy of the mammary gland of the human male may be found in the studies by Graumann, 1952, 1953, and Dabelow, 1957.)

#### 4. Mammary Development during Pregnancy

It has been customary to divide mammary changes during pregnancy into two phases, a phase of growth and a secretory phase. In the former there occurs hyperplasia of the mammary parenchyma whereas, in the latter, the continued increase in gland size is due to cell hypertrophy and the distension of the alveoli with secretion (see Folley, 1952a). Although it was realized that these two phases merged gradually, recent studies have confirmed early reports (e.g., those of Cole, 1933; Jeffers, 1935) that a wave of cell division occurs in the mammary gland towards the end of parturition or at the beginning of lactation. Altman (1945) described a doubling in number of cells per alveolus in the mammary gland of the cow at parturition, but the statistical significance of his findings is difficult to assess. More recently, however, Greenbaum and Slater (1957a) found that the DNA content of the rat mammary gland doubled between the end of pregnancy and the 3rd day of lactation, a finding which they interpret as resulting in the main from hyperplasia of the gland cells. Likewise in the mouse mammary gland, Lewin (1957) observed between parturition and the 4th day of lactation a great increase both in the DNA content of the mammary gland and in the total cell count. Studies on the factors controlling this wave of cell division are awaited with interest. Also associated with the onset of copious milk secretion is a considerable increase in cell volume and coincidentally the mitochondria elongate and may increase in diameter (Howe, Richardson and Birbeck, 1956). Cross, Goodwin and Silver (1958) have followed the histologic changes in the mammary glands of the sow, by means of a biopsy technique, at the end of pregnancy, during parturition, and at weaning. At the end of pregnancy there was a progressive distension of the alveoli, the existing hyaline eosinophilic secretion within the alveoli was gradually replaced by a basophilic material, and fat globules appeared. At parturition the alveoli were contracted and their walls appeared folded (Fig. 10.3).



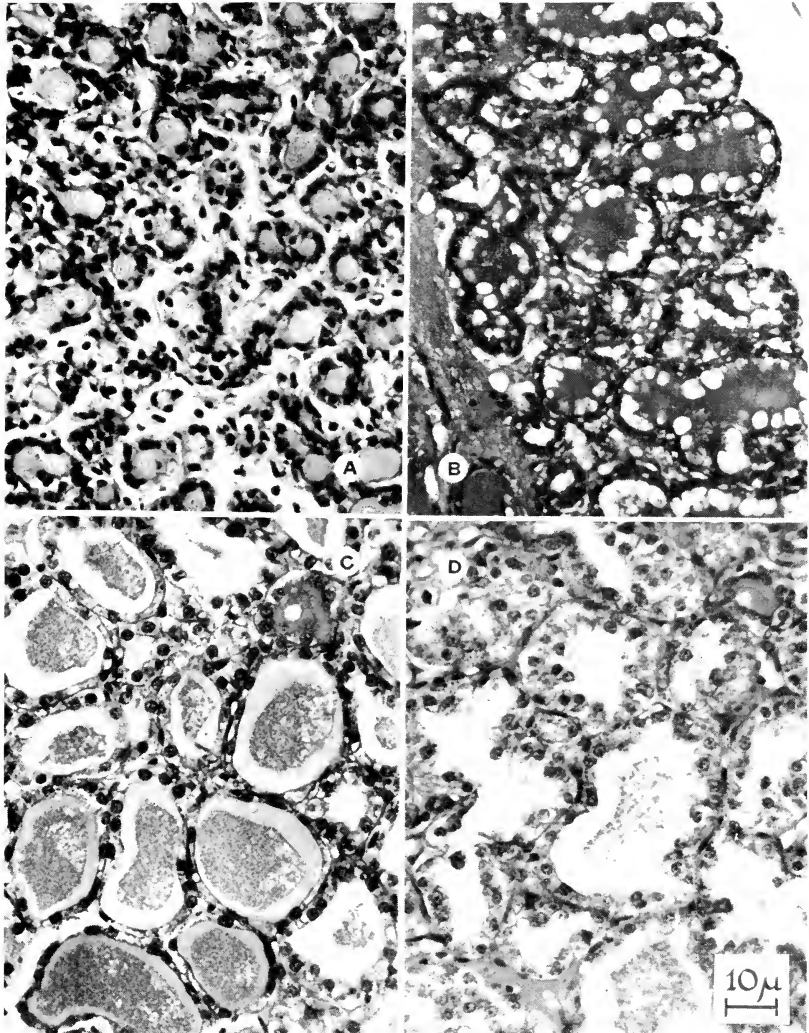

FIG. 103. Sections of biopsy specimens from the mammary gland of a sow before and during parturition. *A*, Six days before parturition: the mammary alveoli are small and contain a nongranular eosinophilic secretion. *B*, Two days before parturition: alveoli have increased in size and fat globules are conspicuous. *C*, Fifteen hours before parturition: alveoli are now distended with secretion which consists of an outer zone of eosinophilic material and fat globules, and a central zone of basophilic granular secretion. *D*, During parturition: alveoli contracted with folded epithelium and sparse secretion. (From B. A. Cross, R. F. W. Goodwin and I. A. Silver, *J. Endocrinol.*, **17**, 63-74, 1958.)

### 5. Mammary Involution

The involutionary changes which occur in the mammary gland after weaning in various species were described in the previous edition of this book (Turner, 1939) and in a later review by Folley (1952a). Since that time, a few further studies have appeared.

There is evidence that the course of the histologic changes in the regressing mammary gland may differ according to whether the young are weaned after lactation has reached its peak and is declining, or whether they are removed soon after parturition, when the effects of engorgement with milk seem to be more marked (see, for example, Williams, 1942, for the mouse). In rats whose young were weaned soon after parturition Silver (1956) was able to re-establish lactation provided suckling was resumed within 4 or 5 days; after that time irreversible changes in the capillary blood supply to the alveoli had set in. A further point arises from a study on the cow by Mosimann (1949) which indicates that the course of the regressive changes in a gland which has undergone one lactation only may differ from those seen in glands from multiparous animals. Oshima and Goto (1955) have used quantitative histometric methods in a study of the involuting rat mammary gland; the values which they obtained for the percentage parenchyma 7 to 10 days after removal of the young agree quite well with those reported by Benson and Folley (1957b) for rats weaned at the 4th day and killed 9 days later.

The biochemical changes occurring in mammary tissue during involution are of some interest and have been studied in our laboratory by McNaught (1956, 1957). She studied mammary slices taken from rats whose young were removed at the 10th day and also slices from suckled glands, the escape of milk from which was prevented by ligation of the galactophores, the other glands in the same animals remaining intact and serving as controls. Her results, some of which are summarized in Figure 10.4, suggest that functional changes which may be taken as indicative of involution (decrease in oxygen up-take, respiratory quotient (R.Q.), and glucose up-take; increase in lactic acid production) are seen as early as

8 to 12 hours after weaning. Continued suckling without removal of milk retards the onset of these changes, but only for some hours. Injections of oxytocin into the rats after weaning (see page 607) did not retard these biochemical changes. Essentially similar results were independently reported by Ôta and Yokoyama (1958) and Mizuno and Chikamune (1958).

### C. EXPERIMENTAL ANALYSIS OF HORMONAL INFLUENCES

#### 1. Ovarian Hormones in the Animal with Intact Pituitary

We shall see later (page 602) that the mammogenic effects of the ovarian hormones are largely dependent on the integrity of the anterior pituitary and thus to analyze accurately the role of hormones in mammary development it is necessary to use hypophysectomized animals. Information of considerable academic and practical importance has been obtained, however, from studies in the animal with intact pituitary and these we shall now consider.

Early studies involving hormone administration pointed to the conclusion that estrogens were in general responsible for the growth of the mammary ducts, whereas progesterone was necessary for complete lobule-alveolar growth (see reviews by Turner, 1939; Folley and Malpress, 1948a; Folley, 1952a). The foundation for this general statement is now more sure, for as a result of experimental studies over the last 10 years, what seemed to be exceptions to this generalization have been shown to be otherwise. In some species (mouse, rat, guinea pig, and monkey) it is true that progesterone alone, if given in sufficiently large doses, will evoke duct and alveolar development in the ovariectomized animal, but this is probably a pharmacologic rather than a physiologic effect. There are great differences in the response of the mammary ducts to estrogen and on this basis it has become usual to divide species into three broad categories (see Folley, 1956). It is, however, necessary to add the warning that in the estrogen-treated spayed animal progesterone from the adrenal cortex may synergize with the exogenous estrogen (see Folley, 1940; Trentin and Turner, 1947; Höhm, 1957) and it may

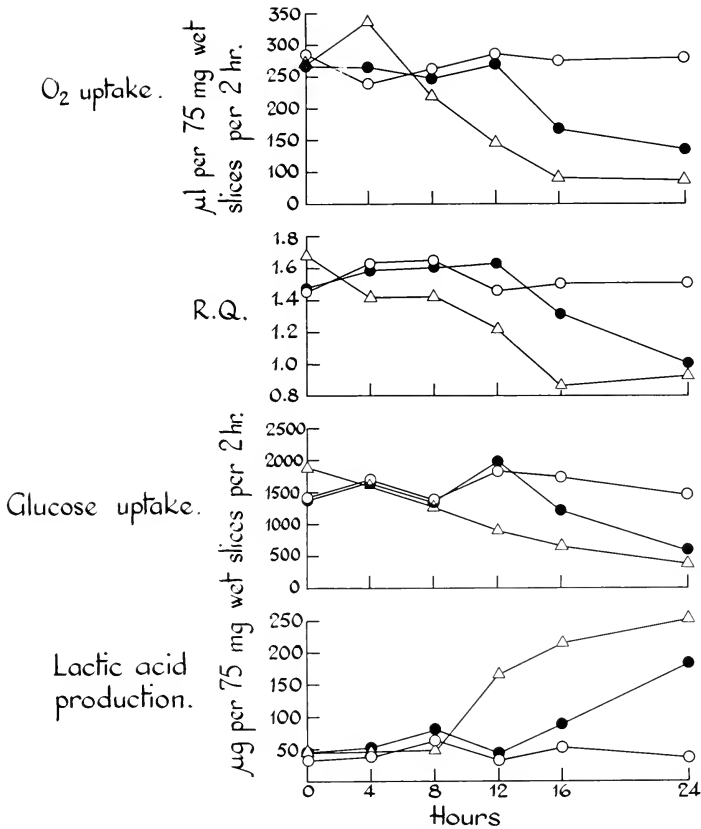

FIG. 10.4. Oxygen uptake, respiratory quotient, glucose uptake, and lactic acid production of mammary gland slices from lactating rats killed at various times after weaning ( $\Delta$ — $\Delta$ ) and from rats in which suckling was maintained, but in which the galactophores of certain glands were ligatured ( $\bullet$ — $\bullet$ ) to prevent the escape of milk, the nonligatured glands ( $\circ$ — $\circ$ ) acting as controls. (Courtesy of Dr. M. L. McNaught.)

be that the real basis for the categories is to be found largely in differences in endogenous progesterone production by the adrenal cortex.

The first category comprises those in which estrogens, in what are believed to be physiologic doses, evoke primarily and mainly duct growth; alveoli may appear, but only if high doses are given and the administration is prolonged. Examples of this class are the mouse, rat, rabbit, and cat. Silver (1953a), using the relative-growth technique, has obtained information on the

levels of estrogen necessary for normal mammary duct growth in the nonpregnant rat. In the young ovariectomized rat, the normal mammary growth rate was best imitated by injecting 0.1  $\mu\text{g}$ . estradiol dipropionate every second day (from 21 days of age) and increasing the dose step-wise with body weight. In the ovariectomized mouse, Flux (1954a) found it necessary to give 0.055  $\mu\text{g}$ . estrone daily to attain mammary duct growth comparable with that observed in intact mice.

In the second category are those species

in which estrogen in physiologic doses causes growth of the ducts and the lobule-alveolar system, the classical example being the guinea pig in which functional mammae can be developed after gonadectomy in either sex by estrogen alone. A recent study by Höhn (1957), however, strongly suggests that progesterone from the adrenal cortex participates in the effect. The earlier view, moreover, that complete mammary growth can be evoked in the gonadectomized guinea pig by estrogen alone (Turner and Gomez, 1934; Nelson, 1937) does not find support in the recent study of Benson, Cowie, Cox and Goldzveig (1957), who, using both subjective and objective methods of assessing the degree of mammary development, found that over a wide dose range of estrone, further development of the mammary gland was obtained when progesterone was also administered; essentially similar conclusions have been reached by Smith and Richterich (1958).

Also in this second category are cattle and goats in which, however, the male mammary gland is not equipotential with that of the female. The early studies on these species have been reviewed at length by Folley and Malpress (1948a) and Folley (1952a, 1956). Briefly it may be said that these studies clearly showed that estrogen alone induced extensive growth of lobule-alveolar tissue of which the functional capacity was considerable although the milk yields in general were less than those expected from similar animals after parturition. The response to estrogen treatment was, moreover, very erratic. It was generally believed that the deficiencies of this treatment could be made good if progesterone were also administered, a view supported by the observations of Mixner and Turner (1943) that the mammary gland of goats treated with estrogens, when examined histologically, showed the presence of cystic alveoli, an abnormality which tended to disappear when progesterone was also administered.

When progesterone became more readily available, an extensive study of the role of estrogen and progesterone in mammary development in the goat was carried out (Cowie, Folley, Malpress and Richardson,

1952; Benson, Cowie, Cox, Flux and Folley, 1955). The mammary tissue was examined histologically and the procedure devised by Richardson (see page 594) used to estimate the area and "porosity" of the alveolar epithelium. The udders grown in immaturely ovariectomized virgin goats by combined treatment with estrogens and progesterone in various proportions and at different absolute dose levels were compared with udders resulting from treatment with estrogen alone. As in the earlier observations of Mixner and Turner (1943), histologic abnormalities were noted, the more widespread being a marked deficiency of total epithelial surface, associated with the presence of cystic alveoli, in the udders of the estrogen-treated animals. The addition of progesterone prevented the appearance of many of these abnormalities and increased the surface area of the secretory epithelium. Moreover, when estrogen and progesterone were given in a suitable ratio and absolute level the milk yields obtained were remarkably uniform as between different animals and the glandular tissue was virtually free from abnormalities.

Studies in the cow have been less extensive, but there is evidence that both estrogen and progesterone are necessary for complete normal mammary development (Sykes and Wrenn, 1950, 1951; Reineke, Meites, Cairy and Huffman, 1952; Flux and Folley, cited by Folley, 1956; Meites, 1960).

The case for the inclusion of the monkey in the present category has been strengthened by the excellent monograph of Speert (1948) who has had access to more extensive material than many of the earlier workers whose results are reviewed by him (see also Folley, 1952a). The sum total of available evidence now justifies the conclusion that estrogen alone will cause virtually complete growth of the duct and lobule-alveolar systems of the monkey breast. Extensive lobule-alveolar development in the monkey breast in response to estrogen is shown in Figure 10.5. The synergistic effect of estrogen and progesterone on the monkey breast has not yet been adequately studied, but from available evidence it does not seem to be very dramatic. If it is permissible to argue from primates to man, it seems possible that could

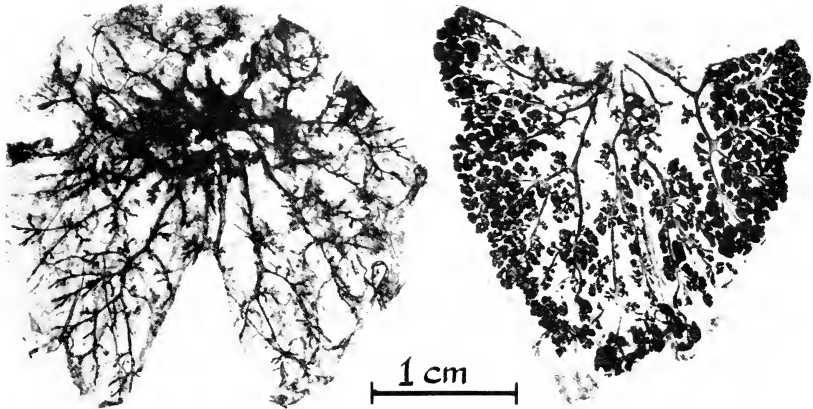

FIG. 10.5. Whole mounts of breast of an ovariectomized immature female rhesus monkey before (*left*) and after (*right*) estrogen treatment. (From H. Speert, *Contr. Embryol.*, Carnegie Inst. Washington, **32**, 9-65, 1948.)

the necessary experiments be done the human breast would show a considerable growth response to estrogen alone.

Finally, in the third category are those species in which estrogen in physiologic doses causes little or no mammary growth. The bitch and probably the ferret seem to belong to this class (see Folley, 1956).

There has been considerable discussion in the past regarding the ratio of progesterone to estrogen optimal for mammary growth. Only recently, however, has this question been fully investigated in any species. Benson, Cowie, Cox and Goldzweig (1957) have shown that in the guinea pig the absolute quantities of progesterone and estrogen are the crucial factors in controlling mammary growth; altering the dose levels but maintaining the ratio gave entirely different growth responses. In view of the varying ability of the different estrogens to stimulate mammary duct growth (Reece, 1950) it is essential in discussing ratios to take into consideration the nature of the estrogen used, a fact not always recognized in the past.

## 2. Anterior Pituitary Hormones

Soon after the discovery by Stricker and Grueter (1928, 1929) of the lactogenic effects of anterior pituitary extracts, it was

shown that anterior pituitary extracts had a mammogenic effect in the ovariectomized animal and that the ovarian steroids had little or no mammogenic effect in hypophysectomized animals. C. W. Turner and his colleagues postulated that mammogenic activity of the anterior pituitary was due to specific factors which they termed "mam-mogens"; other workers, in particular W. R. Lyons, believed the mammogenic effect was due to prolactin. The theory of specific mam-mogens has been fully reviewed in the past (Trentin and Turner, 1948; Folley and Malpress, 1948a) and we do not propose to discuss it further for there is now little evidence to support it. Damm and Turner (1958), while recently seeking new evidence for the existence of a specific pituitary mam-mogen, concur in the view expressed by Folley and Malpress (1948a) that final proof of the existence of a specific mam-mogen will depend on the development of better assay techniques and the characterization or isolation of the active principle.

The mammogenic effects of prolactin were observed in the rabbit by Lyons (1942) who injected small quantities of prolactin directly into the galactophores of the suitably prepared mammary gland. Milk secretion occurred but Lyons also noted that the prolactin caused active growth of the alveo-

lar epithelium. Recently, Mizuno, Iida and Naito (1955) and Mizuno and Naito (1956) have confirmed Lyons' observations on the mammatogenic effect of intraduct injections of prolactin in the rabbit both by histologic and biochemical means (DNA estimations) and there seems little doubt that the prolactin is capable of exerting a direct effect on the growth of the mammary parenchyma, at least in the rabbit whose pituitary is intact.

In the last 18 years much information on the role of the anterior pituitary in mammary growth has been obtained by Lyons and his colleagues in studies on hypophysectomized, hypophysectomized-ovariectomized, and hypophysectomized-ovariectomized-adrenalectomized (triple operated) rats of the Long-Evans strain. In 1943 Lyons showed that in the hypophysectomized-ovariectomized rat, estrogen + progesterone + prolactin induced lobule-alveolar development, but the degree of development was less than that obtained in the ovariectomized rat with intact pituitary receiving estrogen and progesterone. When supplies of purified anterior-pituitary hormones became available the experiments were extended (Lyons, Li and Johnson, 1952) and it was shown that if somatotrophin (STH) was added to the hormone combination of estrogen + progesterone + prolactin, the degree of lobule-alveolar development obtained in the hypophysectomized-ovariectomized rat was much enhanced. The omission of prolactin from the hormonal tetrad prevented lobule-alveolar development from occurring. In the hypophysectomized-ovariectomized-adrenalectomized rat the above hormonal tetrad could also evoke lobule-alveolar development, provided the animals were given saline to drink (Lyons, Li, Cole and Johnson, 1953). In yet more recent experiments Lyons, Li and Johnson (1958) observed that somatotrophin has a direct stimulatory effect on duct growth, but in the hypophysectomized-ovariectomized rat, the presence of estrogen is also necessary to evoke normal duct development (Fig. 10.6*a, b, c*); Likewise, in the triple operated rat, STH plus estrogen is mammatogenic, but the presence of a corticoid is required to obtain full duct de-

velopment (Fig. 10.6*d*). Lyons and his colleagues were able to build up the mammary glands of triple operated rats from the state of bare regressed ducts to full prolactational lobule-alveolar development by giving estrogen + STH + corticoids for a period of 10 days to obtain duct proliferation followed by a further treatment (for 10 to 20 days) with estrone + progesterone + STH + prolactin + corticoid to induce lobule-alveolar development. Milk secretion could then be induced by a third course of treatment lasting about 6 days in which only prolactin and corticoids were given (Fig. 10.6*e, f*). Essentially similar results have been obtained in studies with the hooded Norway rat (Cowie and Lyons, 1959).

Studies on mammatogenesis in the hypophysectomized mouse have revealed some differences in the response of the mammary gland of this species in comparison with that of the rat and indications of strain differences within the species. The mammary gland of the hypophysectomized male weanling mouse of the Strong A2G strain shows no response to the ovarian steroids alone, to prolactin, or to STH alone, but it responds with vigorous duct proliferation to combinations of estrogen + progesterone + prolactin, or of estrogen + progesterone + STH (Hadfield, 1957; Hadfield and Young, 1958). In the hypophysectomized male mouse of the CHI strain slight duct growth occurs in response to estrogen + progesterone and this is much enhanced when STH is also given; the further addition of prolactin then results in alveolar development (Flux, 1958). Extensive studies in triple operated mice of the C3H HeCrgl strain have been reported by Nandi (1958*a, b*). In this strain some duct growth was observed in triple operated animals in response to steroids alone (estrogen + progesterone + corticoids), but normal duct development was believed to be due to the action of estrogen + STH + corticoids, a conclusion in agreement with Lyons' observations in the rat. Extensive lobule-alveolar development could be induced by a number of hormone combinations, one of the most effective being estrogen + progesterone + corticoids + prolactin + STH, milk secretion occurring when the ovarian

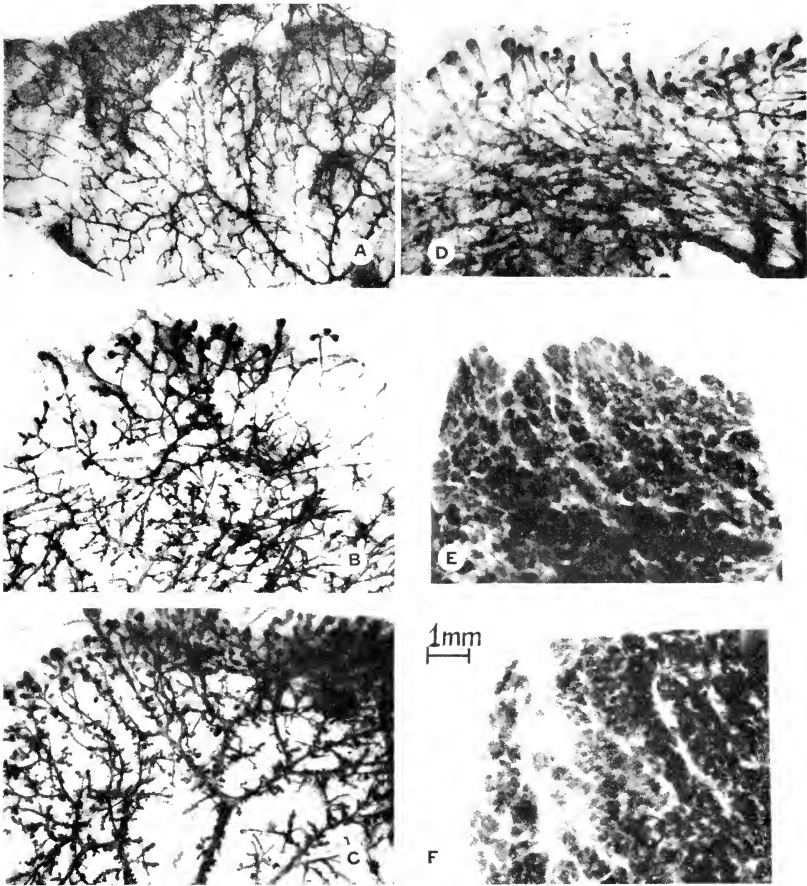

FIG. 10.6. Typical areas of whole mounts of the abdominal mammary gland of rats after the following treatments: *A*. Untreated rat on day 31, 14 days after hypophysectomy. The gland has regressed to a bare duct system. *B*. Rat hypophysectomized and ovariectomized on day 30 and injected daily with 2 mg. somatotrophin (STH) for 7 days. Note the presence of end clubs. *C*. Rat treated as in *B* but which received, in addition to the STH, 1  $\mu$ g. estrone. Note profuse end-club proliferation. *D*. Rat hypophysectomized on day 30, ovariectomized and adrenalectomized on day 60, and injected daily from days 60 to 69 with 1 mg. STH + 0.1 mg. DCA + 1  $\mu$ g. estrone. Note again the profuse number of end buds indicative of duct proliferation. *E*. Same treatment as in *D* followed by 10 days treatment with 5 mg. prolactin + 2 mg. STH + 1  $\mu$ g. estrone + 2 mg. progesterone + 0.1 mg. DCA + 0.05 mg. prednisolone acetate. Note excellent lobule-alveolar growth. *F*. Same treatment as in *D* followed by 20 days treatment with 5 mg. prolactin + 2 mg. STH + 1  $\mu$ g. estrone + 2 mg. progesterone + 0.1 mg. DCA + 0.05 mg. prednisolone acetate; thereafter given 0.1 mg. prolactin locally over this gland and 0.1 mg. DCA + 0.1 mg. prednisolone acetate systemically for 6 days. Note fully developed lobules with alveoli filled with milk. (All glands at the same magnification.) (From W. R. Lyons, C. H. Li and R. E. Johnson, *Recent Progr. Hormone Res.*, **14**, 219-254, 1958.)

steroids were withdrawn, while the prolactin, STH, and cortisol were continued. A further interesting observation made by Nandi is that in the C3H, HeCrg1 mouse STH can replace prolactin in the stimulation of all phases of mammary development and in the induction of milk secretion; enhanced effects were obtained, however, when prolactin and STH were given together. Nandi also considers that progesterone plays a greater role in duct development in the mouse than in the rat.

The above experiments clearly indicate that both in the triply operated rat and mouse, it is possible to build up the mammary gland to the full prolactational state by injecting the known ovarian, adrenal cortical, and anterior pituitary hormones. There would thus seem to be no necessity to postulate the existence of other unidentified pituitary mammogens. It must be recognized, however, that in normal pregnancy the placenta may be an important source of mammogenic hormones. The placenta of the rat contains a substance or substances possessing luteotrophic, mammogenic, lactogenic, and crop-sac stimulating properties, but it is uncertain whether this material is identical with pituitary prolactin (Averill, Ray and Lyons, 1950; Canivene, 1952; Canivene and Mayer, 1953; Ray, Averill, Lyons and Johnson, 1955). There is also some evidence of the presence of a somatotrophin-like principle in rat placenta (Ray, Averill, Lyons and Johnson, 1955).

### 3. *Metabolic Hormones (Corticoids, Insulin, and Thyroid Hormones)*

We have already noted that Lyons and his colleagues were able to obtain full duct development in the triply operated rat only when corticoids were given. Early studies of the role of the adrenals in mammary development have given conflicting and uncertain results (see review by Folley, 1952a). Recent studies have not entirely clarified the position. Flux (1954b) tested a number of 11-oxygenated corticoids, and found that not only were they devoid of mammogenic activity in the ovariectomized virgin mouse, but that they inhibited the growth-promoting effects of estrogen on the mammary ducts, whereas 11-desoxycorticosterone acted synergistically with estro-

gen in promoting duct growth. In subsequent studies it was shown that injections of adrenocorticotrophin (ACTH) into intact female mice did not influence mammary growth (Flux and Mumford, 1957), but that cortisol acetate in low doses (12.5  $\mu\text{g}$ . per day) stimulated mammary development in ovariectomized and in ovariectomized estrone-treated mice, whereas at higher levels (25 and 50  $\mu\text{g}$ . per day) it was without effect (Mumford, 1957). In the virgin rat, on the other hand, glucocorticoids are said to stimulate mammary growth and to induce milk secretion (Selye, 1954; Johnson and Meites, 1955). Some light on these conflicting results has been shed by the studies of Ahrén and Jacobsen (1957) who investigated the effects of cortisone on the mammary glands of ovariectomized and of ovariectomized-hypophysectomized rats, both in the presence and absence of exogenous ovarian hormones. In the hypophysectomized animals, cortisone promoted enlargement and proliferation of the epithelial cells lining the duct walls, but normal growth and differentiation did not occur, nor did the addition of estrogen and progesterone appreciably alter these effects; in rats with intact pituitaries, however, cortisone stimulated secretion but not mammary growth, whereas the addition of estrogen and progesterone promoted both growth and abundant secretion. Ahrén and Jacobsen concluded that "the effect elicited by cortisone in the mammary gland should be analysed with due regard to the endocrine state of the animal both as to its effects on the structures of the mammary gland and to the consequences resulting from an eventual upset of the general metabolic equilibrium." They consider that in circumstances optimal for mammary gland growth and maintenance of homeostasis the predominant actions of cortisone are enhancement of alveolar growth and stimulation of secretion, whereas under conditions in which the metabolic actions of cortisone are not efficiently counteracted, gland growth is either inhibited or an abnormal development of certain mammary cells may be evoked.

That the general metabolic milieu may indeed profoundly influence the response of the mammary gland to hormones has



been emphasized by the recent experiments of Jacobssohn and her colleagues. Following on the work of Salter and Best (1953) who showed that hypophysectomized rats could be made to resume body growth by the injections of long-acting insulin, Jacobssohn and her colleagues (Ahrén and Jacobssohn, 1956; Ahrén and Etienne, 1958; Ahrén, 1959) found that treatment with estrogen and progesterone would stimulate considerable mammary duct growth in hypophysectomized-gonadectomized rats when given with suitable doses of long-acting insulin (Fig. 10.7). This growth-supporting effect of insulin could be nullified if cortisone was also administered (Ahrén and Jacobssohn, 1957) but could be enhanced by giving thyroxine (Jacobssohn, 1959).

The thyroid would thus appear to be another endocrine gland whose hormones affect

mammary growth indirectly by altering the metabolic environment. Studies in this field, reviewed by Folley (1952a, 1956), indicate that in the rat some degree of hypothyroidism enhances alveolar development whereas in the mouse, hypothyroidism seems to inhibit mammary development. Chen, Johnson, Lyons, Li and Cole (1955) have shown that mammary growth can be induced in hypophysectomized-adrenalectomized-thyroidectomized rats by giving estrone, progesterone, prolactin, STH, and cortisol, no replacement of the thyroid hormones being necessary.

These investigations on the effect of the metabolic environment on mammary development seem to be opening up new avenues of approach to the advancement of our understanding of the mechanisms of mammary growth and we would recommend,

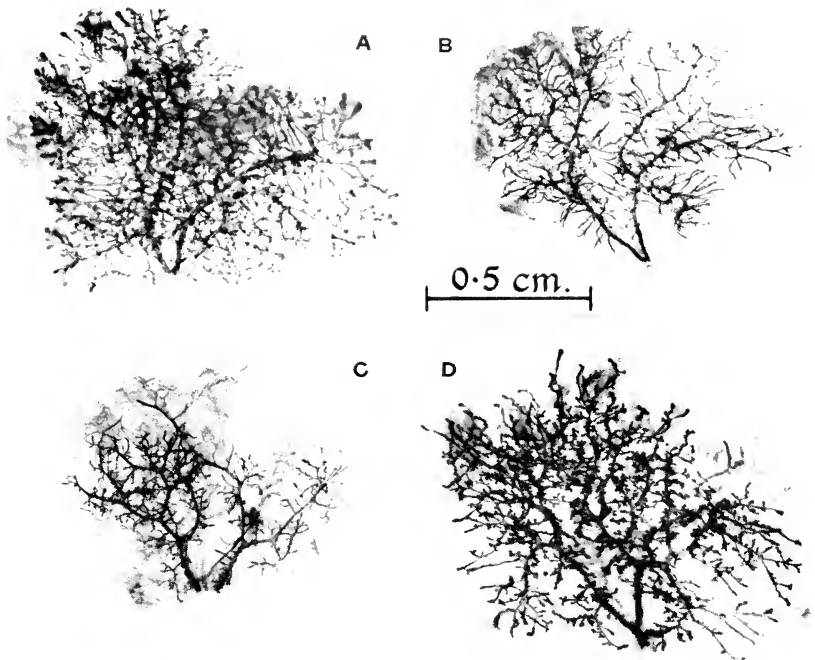

FIG. 10.7. Whole mount preparation of second thoracic mammary gland of: A. Ovariectomized rats injected with estrone and progesterone. B. Hypophysectomized-ovariectomized rat injected with estrone and progesterone. C. Hypophysectomized-ovariectomized rat. D. Hypophysectomized-ovariectomized rat injected with estrone, progesterone, and insulin. (From K. Ahrén and D. Jacobssohn, *Acta physiol. scandinav.*, **37**, 190-203, 1956.)

to those seeking further information about this important new field, the recent review by Jacobssohn (1958).

### III. Endocrine Influences in Milk Secretion

#### A. ANTERIOR PITUITARY HORMONES

##### 1. Initiation of Secretion (*Lactogenesis*)

The early experiments leading to the view that the anterior pituitary was not only necessary for the initiation of milk secretion, but in fact provided a positive lactogenic stimulus, are now well known and the reader is referred to the reviews by Folley (1952a, 1956) and Lyons (1958) for further particulars. That pituitary prolactin can evoke milk secretion in the suitably developed mammary gland of the rabbit with intact pituitary has been amply confirmed, and the original experiments of Lyons (1942) involving the intraduct injection of prolactin have been successfully repeated by Meites and Turner (1947) and

Bradley and Clarke (1956) (Fig. 10.8). However, endogenous pituitary hormones may have participated in the response in such experiments and in the last 20 years there has been considerable discussion as to whether prolactin should be regarded as *the* lactogenic hormone or as a *component* of a lactogenic complex. This whole question has been fully discussed in recent years (see Folley, 1952a, 1956) and it now seems reasonably certain that lactogenesis is a response to the co-operative action of more than one anterior pituitary hormone, that is, to a lactogenic hormone complex of which prolactin is an important component, as first suggested by Folley and Young (1941). The recent reports by Nandi (1958a, b) that STH + cortisol can induce milk secretion in triply operated mice with suitably developed glands is further strong evidence against regarding prolactin as *the* lactogenic hormone.

Secretory activity is evident in the mammary gland during the second half of pregnancy, but abundant milk secretion does not set in until parturition or shortly thereafter. The nature of the mechanism controlling the initiation of abundant secretion has been the subject of speculation for many years. The earlier theories were discussed by Turner (1939) in the second edition of this book, and included the theory put forward by Nelson with reference to the guinea pig, that the high levels of blood estrogen in late pregnancy suppressed the secretion or release of prolactin from the pituitary and had also a direct inhibitory effect on the mammary parenchyma, the fall in the levels of estrogen occurring at parturition then allowing the anterior pituitary to exert its full lactogenic effect. This concept proved inadequate to explain observations in other species and it was later extended by Folley and Malpress (1948b) to embrace the concept of two thresholds for opposing influences of estrogen upon pituitary lactogenic function, a lower threshold for stimulation and a higher one for inhibition. Subsequent observations on the inhibitory role of progesterone, in the presence of estrogen, on milk secretion, however, necessitated further modification of the theory. Before discussing these modifica-

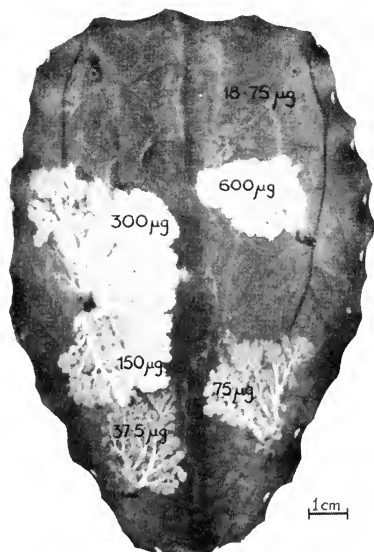

Fig. 10.8. Lactational responses in pseudopregnant rabbit to different doses of prolactin injected intraductally. (From T. R. Bradley and P. M. Clarke, *J. Endocrinol.*, **14**, 28-36, 1956.)

tions it is convenient to refer to the ingenious theory put forward by Meites and Turner (1942a, b; 1948) which was based on their extensive investigation of the prolactin content of the pituitary in various physiologic and experimental states. According to Meites and Turner, estrogen elicits the secretion of prolactin from the anterior pituitary thereby causing lactogenesis, whereas progesterone is an inhibitory agent, operative in pregnancy, inhibiting or over-riding the lactogenic action of estrogen. The induction of lactation was thus ascribed to a fall in the body level of progesterone relative to that of estrogen believed to occur at the time of parturition. Subsequent studies in the rabbit by Meites and Sgouris (1953, 1954) revealed that combinations of estrogen and progesterone could inhibit, at the mammary gland level, the lactogenic effects of exogenous prolactin. This effect was, however, relative and by increasing the prolactin or decreasing the steroids, lactogenesis ensued. Inasmuch as the theory of Meites and Turner did not take into account the eventuality that estrogen and progesterone act at the level of the mammary gland, Meites (1954) modified the concept, postulating that milk secretion was held in check during pregnancy first by the combined effect of estrogen and progesterone which make the mammary gland refractory to prolactin and, secondly, by a low rate of prolactin secretion. The role of progesterone in over-riding the stimulatory effect of estrogen on the pituitary he now considered to be of only minor importance. Meites also explained the continuance of lactation in pregnant animals by postulating that the initial level of prolactin was sufficiently high as a result of the suckling stimulus to overcome the inhibitory action of the ovarian hormones on the mammary gland. One of us (Folley, 1954, 1956) put forward a tentative theory, combining various features of previous hypotheses, which seemed capable of harmonizing most of the known facts regarding the initiation of milk secretion. In this it was emphasized that measurements of the prolactin content of the pituitary were not necessarily indicative of the rate of prolactin release (a recent study by Grosvenor and Turner (1958c)

lends further support to this contention) and were best considered as largely irrelevant; low circulating levels of estrogen activate the lactogenic function of the anterior pituitary whereas higher levels tend to inhibit lactation even in the absence of the ovary; lactogenic doses of estrogen may be deprived of their lactogenic action by suitable doses of progesterone, the combination then acting as a potent inhibitor of lactation, this being the influence operating in pregnancy; at parturition the relative fall in the progesterone to estrogen ratio removes the inhibition which is replaced by the positive lactogenic effect of estrogen acting unopposed.

It was observed by Gaines in 1915 that although a colostrum secretion accumulated in the mammary gland during pregnancy, the initiation of copious secretion was associated with functioning of the contractile mechanisms in the udder responsible for milk ejection; later Petersen (1944) also suggested that the suckling or milking stimulus might be partly responsible for the onset of lactation. Recent studies have provided evidence that this may well be so, and these will be considered later when discussing the role of the suckling and milking stimulus in the maintenance of milk secretion (see page 611).

During the past decade a fair amount of information has been obtained about the biochemical changes which occur in mammary tissue near the time of parturition, and which are almost certainly related to lactogenesis. The earlier work has been reviewed in some detail by one of us (Folley, 1956) and need only be referred to briefly here.

Folley and French (1949), studying rat mammary gland slices incubated in media containing glucose, showed that  $-QO_2$  increased from a value of about 1.3 in late pregnancy to a value of about 4.4 at day 1 of lactation, and thereafter increased still further. At the same time the R.Q. which was below unity (approximately 0.83) at the end of pregnancy, increased to unity soon after parturition, and by day 8 had reached a value of 1.62 at approximately which level it remained for the rest of the lactation period. In accord with the

increase of respiratory activity of the tissue about the time of parturition in the rat mammary gland, Moore and Nelson (1952) reported increases in the content of certain respiratory enzymes, succinic oxidase and cytochrome oxidase, in the guinea pig mammary gland at about this time. Greenbaum and Slater (1957b) made similar observations about mammary gland succinic oxidase in the rat. Recent work is beginning to throw light on the metabolic pathways involved in this increase in respiratory activity. Thus McLean (1958a) has adduced evidence indicating an increase in the activity of the pentose phosphate pathway in the rat mammary gland at about the time of parturition. Mammary gland slices taken from rats at various stages of the lactation cycle were incubated in media containing either glucose 1- $C^{14}$  or glucose 6- $C^{14}$ , and the amount of radioactivity appearing in the respiratory  $CO_2$  was determined. The results given in Figure 10.9 show that although the recovery of  $C^{14}O_2$  from C-6 was relatively unaffected by the initiation of lactation, the  $C^{14}O_2$  originating from C-1 began a striking increase at the time of parturition (see also Glock, McLean and Whitehead, 1956, and Glock and McLean, 1958, from which Figure 10.9 was taken).

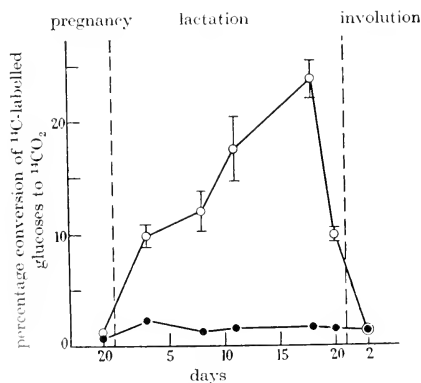

FIG. 10.9. The relative amounts of  $C^{14}O_2$  formed from glucose 1- $C^{14}$  and glucose 6- $C^{14}$  by rat mammary gland slices.  $\circ$ — $\circ$ ,  $C^{14}O_2$  formed from glucose 1- $C^{14}$ .  $\bullet$ — $\bullet$ ,  $C^{14}O_2$  formed from glucose 6- $C^{14}$ . (From G. E. Glock and P. McLean, Proc. Roy. Soc., London, ser. B, 149, 354-362, 1958.)

Despite the well known pitfalls which surround the interpretation of C-1:C-6 quotients in experiments such as these, it seems clear that lactation is associated with an increase in the metabolism of glucose by the pentose phosphate cycle, whereas the proportion going by the Embden-Meyerhof pathway would appear to be relatively unaffected. These conclusions are supported by the fact that the levels in rat mammary tissue of two enzymes concerned in this pathway of glucose breakdown, glucose 6-phosphate dehydrogenase and 6-phosphogluconate dehydrogenase, show very striking increases at the time of parturition (Glock and McLean, 1954; McLean, 1958a). Other enzymes concerned in glucose breakdown whose activities in mammary tissue begin to increase at parturition are hexokinase and phosphoglucose isomerase (McLean, 1958a). In connection with the glucose metabolism of rat mammary tissue it may be noted that addition of insulin to the incubation medium markedly increases the  $-QO_2$  and R.Q. of rat mammary slices metabolizing glucose or glucose plus acetate (see page 619), and that this tissue only becomes sensitive to insulin just after parturition (Bahmain and Folley, 1951). It is interesting to speculate which of the two above-mentioned pathways of glucose breakdown in mammary tissue responds to the action of insulin. According to Abraham, Cady and Chaikoff (1957) addition of insulin *in vitro* increased the production by lactating rat mammary slices of  $C^{14}O_2$  from glucose 1- $C^{14}$ , but not from glucose 6- $C^{14}$ , which might indicate that insulin stimulates preferentially the pentose phosphate pathway. Against this, insulin increased the incorporation of both these carbon atoms (and also the 3:4 carbon atoms of glucose) into fatty acids of the slices to about the same extent. McLean (1959) believes that the stimulatory effect of insulin on the pentose phosphate pathway in the lactating rat mammary gland is secondary to its stimulating effect on lipogenesis. The latter process generates the oxidized form of triphosphopyridine nucleotide (TPN) which is needed for the first two steps of the pentose phosphate cycle.

The increase in the R.Q. of mammary

tissue beginning at parturition observed by Folley and French (1949) was interpreted as indicating that this tissue assumes the power of effecting net fatty acid synthesis from glucose at this time. Much subsequent evidence confirming this idea has been reviewed by Folley (1956). It only remains to add that Ringler, Becker and Nelson (1954), Laurysseus, Peeters and Donck (1956), and Read and Moore (1958) have shown that the amount of coenzyme A in mammary tissue undergoes an increase at parturition. Moreover, the recent findings of McLean (1958b), who showed that the levels of pyridine nucleotides in the mammary gland of the rat begin to increase at parturition, reaching a high level by the end of lactation, may be significant in this connection. McLean found that although the increase in the tissue levels of diphosphopyridine nucleotide was almost entirely due to an increase in the oxidized form (DPN), in the case of TPN it was the reduced form (TPNH) which increased. The latter might well be used for reductive syntheses such as lipogenesis.

The rate of synthesis of milk constituents other than fat must also begin to increase at parturition, and Greenbaum and Greenwood (1954) showed that an increase in the levels of glutamic aspartic transaminase and of glutamic dehydrogenase in rat mammary tissue occurs at this time. The authors believe these enzymes are concerned in the provision of substrates for the synthesis of milk protein. It is significant in connection with milk protein synthesis that the mammary gland ribonucleic acid (RNA) in the rat undergoes a marked rise at parturition (Greenbaum and Slater, 1957a).

The above-mentioned biochemical changes in mammary tissue which occur at about the time of parturition are almost certainly closely related to the effect on this tissue of members of the anterior pituitary lactogenic complex, and particularly prolactin. Attempts have been made to elicit the characteristic respiratory changes, described above, in mammary slices *in vitro* by addition of prolactin and adrenal glucocorticoids to the incubation medium (see Folley, 1956). So far, however, definitive results have not been obtained and it is doubt-

ful whether any biochemical changes in lactating mammary gland slices *in vitro* have been demonstrated which could with certainty be ascribed to the action of prolactin (in this connection see also Bradley and Mitchell, 1957).

## 2. Maintenance of Milk Secretion—Galactopoiesis

It is well known that the removal of the pituitary of a lactating animal will end milk secretion (for references see Folley, 1952a). The cessation of milk secretion has been generally ascribed to the loss of the anterior lobe, but when the importance of the neurohypophysis in milk ejection became established (see page 621), it was clear that in the hypophysectomized animal it was necessary to distinguish between a failure in milk secretion and a failure in milk ejection, since either would lead to failure of lactation. It has now been shown in the rat that adequate oxytocin therapy ensuring the occurrence of milk ejection after hypophysectomy will not restore lactation (Cowie, 1957) and it may thus be concluded that the integrity of the anterior lobe is essential for the maintenance of milk secretion. The effect of hypophysectomy on milk secretion is dramatic, because in the rat, milk secretion virtually ceases within a day of the operation and biochemical changes in the metabolic activity of the mammary tissue can be detected within 4 to 8 hours (Bradley and Cowie, 1956). It is of interest to note that these metabolic changes are similar to those observed during mammary involution (see page 598).

Since the second edition of this book, there have been surprisingly few studies on replacement therapy in hypophysectomized lactating animals. In such studies we would stress the need for rigorous methods of assessing the efficacy of treatment. In the past the presence of milk in the gland as revealed by macroscopic or microscopic examination has been regarded as an indication of successful replacement. This, however, gives no measure of the degree of maintenance of lactation and some measure of the daily milk yield of such animals should be obtained (see also Cowie, 1957).

It is also now obvious that oxytocin may have to be injected to ensure milk ejection; under certain circumstances, however, the neurohypophysial tissue remaining after the removal of the posterior lobe may be capable of releasing oxytocin and permitting milk ejection (see Benson and Cowie, 1956; Bintarningsih, Lyons, Johnson and Li, 1957, 1958).

The earliest report on the maintenance of lactation after hypophysectomy is that of Gomez (1939, 1940), who found that hypophysectomized lactating rats could rear their litters if given anterior-pituitary extract, adrenal cortical extracts, glucose, and posterior pituitary extract. These experiments are difficult to assess because they are reported only in abstract, but the use of posterior pituitary extract at a time when the role of oxytocin in milk ejection was not generally recognized is worthy of note. Recently, slight maintenance of milk secretion in hypophysectomized rats has been obtained with prolactin alone, and greater maintenance when adrenocorticotrophic hormone (ACTH) or STH was administered with prolactin (Cowie, 1957). Similar studies were reported by Bintarningsih, Lyons, Johnson and Li (1957, 1958) (see also Lyons, Li and Johnson, 1958) in which

considerable maintenance of milk secretion was obtained in hypophysectomized rats with prolactin and certain corticoids. Of related interest is the observation by Elias (1957) that cortisol and prolactin can induce secretory activity in explants of mouse mammary gland growing on a synthetic medium. (Tissue culture techniques have been little exploited in mammary studies and further developments in this field may be expected.)

The evidence to date suggests that, in the rat, prolactin is an essential component of the hormone complex involved in the maintenance of lactation with ACTH and STH also participating, but further studies are required to determine the most favorable balance of these factors.

Preliminary studies on the maintenance of lactation in the goat after hypophysectomy suggest that both prolactin and STH are important in the initiation and maintenance of milk secretion (Cowie and Tindal, 1960). Our knowledge of the process in other species is derived from studies on the effect of exogenous anterior pituitary hormones on established lactation in intact animals—galactopoietic effects (for reference see Folley, 1952a, 1956). In the cow, considerable increase in milk yield can be obtained by injecting STH (Cotes, Crichton, Folley and Young, 1949), whereas prolactin has a negligible galactopoietic effect (Fig. 10.10; for discussion see also Folley, 1955). Recently the precise relationship between the dose of STH (ox) and the lactational response in the cow was established in our laboratory by Hutton (1957) who observed a highly significant linear relationship between log doses of STH (single injection) and the increase in milk yield obtained (Fig. 10.11); increases in fat yield relative to the yield of nonfatty solids also occurred. In the lactating rat, on the other hand, STH has no galactopoietic effect (Meites, 1957b; Cowie, Cox and Naito, 1957), whereas prolactin has (Johnson and Meites, 1958). Such studies must be interpreted with caution as endogenous pituitary hormones were present; nevertheless, it seems reasonable to conclude that STH is likely to be an important factor in the maintenance of lactation in the cow.

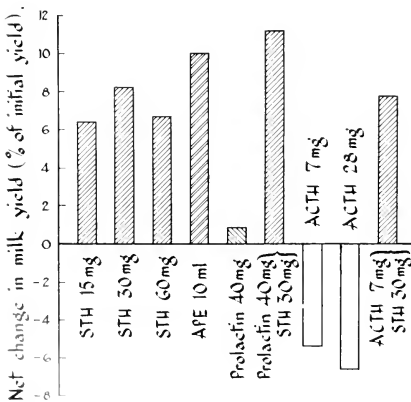

FIG. 10.10. Effect on the milk yield of the cow of injected hormones of the anterior pituitary. (From the results of P. M. Cotes, J. A. Crichton, S. J. Folley and F. G. Young, *Nature*, London, **164**, 992-993, 1949.)

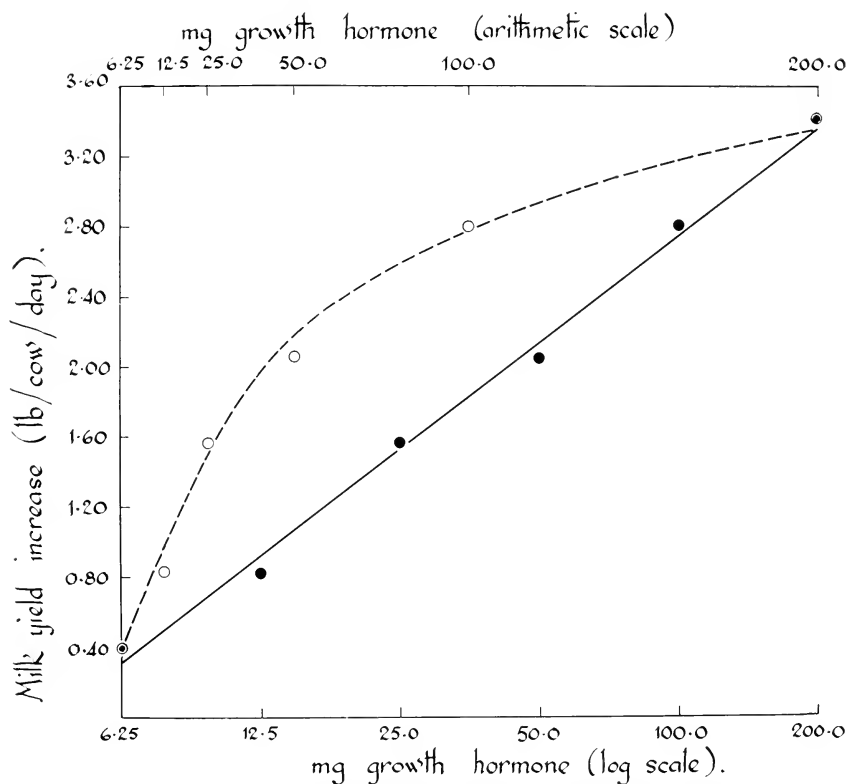

FIG. 10.11. Effect of graded doses of growth hormone on milk yield of cow. *Upper curve*, doses plotted on arithmetic scale. *Lower curve*, doses plotted on logarithmic scale. (From J. B. Hutton, *J. Endocrinol.*, **16**, 115-125, 1957.)

Other hormones of the anterior pituitary in all probability influence milk secretion through their target glands and these will be dealt with later.

### 3. Suckling Stimulus and the Maintenance of Lactation

It has been long believed that regular milking is an important factor in maintaining lactation and that if milk is allowed to accumulate in the gland, as occurs at weaning, atrophy of the alveolar epithelium and glandular involution occur. Evidence in support of this concept was obtained in studies showing that ligation or occlusion of

the main ducts of some of the mammae of a lactating animal resulted in atrophy of the glands concerned although the other glands were suckled normally (Kuranitsu and Loeb, 1921; Hammond and Marshall, 1925; Fauvet, 1941a). Studies by Selye and his colleagues, however, revealed that such occluded glands did not atrophy as quickly as did glands of animals in which the suckling stimulus was no longer maintained (Selye, 1934; Selye, Collip and Thomson, 1934) and it was postulated that the suckling stimulus evoked from the anterior pituitary the secretion of prolactin which maintained the secretory activity of the gland. This theory has been widely accepted

although it has been suggested that a complex of hormones rather than prolactin alone is released (Folley, 1947). Williams (1945) showed that prolactin could in fact maintain the integrity of the mammary gland in the unsuckled mouse thus mimicking the effects of the suckling stimulus; other supporting evidence has been reviewed by Folley (1952a). Recent studies in goats, however, have shown that milk secretion may continue more or less at the normal level after complete denervation of the udder (Tverskoï, 1958; Denamur and Martinet, 1959a, b, 1960) and it may be that in some species the suckling or milking stimulus is less important in the maintenance of milk secretion.

Milk secretion is essentially a continuous process whereas the suckling or milking stimulus is intermittent; indeed the milking stimulus may be of remarkably brief duration (in the cow about 10 minutes in all per 24 hours) and it is therefore likely that the stimulus triggers off the release of sufficient galactopoietic complex to maintain mammary function for some hours. Grosvenor and Turner (1957b) reported that suckling causes a rapid drop in the prolactin content of the pituitary in the rat, and that the prenursing level of prolactin in the pituitary is not fully regained some 9 hours later. It is difficult, however, to relate pituitary levels of prolactin to the rate of its secretion into the circulation and, although these observations are interesting, further advances are unlikely until a method of assay for blood prolactin becomes available and the "half-life" of prolactin in circulation is known.

The experiments of Grégoire (1947) on the maintenance of involution of the thymus during nursing suggests that the suckling stimulus releases ACTH which, as we have seen, is galactopoietic in the rat; thus, so far as the rat is concerned, there would appear to be good evidence that the suckling stimulus releases at least two known important components of the galactopoietic complex.

The milking and suckling stimulus is also responsible for eliciting the milk-ejection reflex and the relation between the two reflexes will be discussed later in this chapter (see page 619).

#### B. HORMONES OF THE ADRENAL CORTEX

Adrenalectomy results in a marked inhibition of milk secretion and the early experiments in this field were reviewed by Turner in 1939. Since then, however, purified adrenal steroids have become available enabling further analysis to be made of the role of the adrenal cortex in lactation.

Gaunt, Eversole and Kendall (1942) considered that in the rat the defect in milk secretion after adrenalectomy could be repaired by the administration of the adrenal steroids most closely concerned with carbohydrate metabolism, whereas we came to the somewhat opposing view that the defect was best remedied by those hormones primarily concerned with electrolyte metabolism (Folley and Cowie, 1944; Cowie and Folley, 1947b, c). The reasons for these differing observations are not yet entirely clear. Virtually complete restoration of milk secretion was subsequently obtained in our strain of rat by the combined administration of desoxycorticosterone acetate (DCA) and cortisone, or with the halogenated steroids, 9 $\alpha$ -chlorocortisol and 9 $\alpha$ -fluorocortisol (Cowie, 1952; Cowie and Tindal, 1955; Cowie and Tindal, unpublished; see also Table 10.1). It would therefore seem that both glucocorticoid and mineralocorticoid activity was necessary to maintain the intensity of milk secretion at its normal level. The interesting observation was made by Flux (1955) and later confirmed by Cowie and Tindal (unpublished) that the ovaries contribute to the maintenance of lactation after adrenalectomy, a contribution which could be simulated in the adrenalectomized-ovariectomized rat by the administration of 3 mg. progesterone daily. The differences in the size of the ovarian contribution may partly account for the apparent differences in various strains of rat of the relative importance of mineralo- and glucocorticoids in sustaining milk secretion after adrenalectomy. The only other species in which the maintenance of lactation after adrenalectomy has been studied is the goat in which, as in the rat, lactation can be maintained with cortisone and desoxycorticosterone, the latter being apparently the more critical steroid (Cowie and Tindal, 1958; Figs. 10.12a, b).



There have been several studies on the effects of corticoids and adrenocorticotrophin on lactation in the intact animal. ACTH and the corticoids depress lactation in the intact cow (Fig. 10.10) (Cotes, Crichton, Folley and Young, 1949; Flux, Folley and Rowland, 1954; Shaw, Chung and Bunding, 1955; Shaw, 1955), whereas in the rat ACTH and cortisone have been reported as exhibiting galactopoietic effects (Meites, private communication; Johnson and Meites, 1958). With larger doses of cortisone, however, an inhibition of milk secretion in the rat has been reported (Mercier-Parot, 1955).

The main function of the cortical steroids in lactation is still uncertain. They may act in a "supporting" or "permissive" manner (see Ingle, 1954), maintaining the alveolar cells in a state responsive to the galactopoietic complex, or they may act by maintaining the necessary levels of milk precursors in the blood.

Biochemical studies are, however, beginning to add to our information on the role of the corticoids in lactation. In the rat, adrenalectomy prevents the increase in liver and mammary gland arginase which occurs during normal lactation and it has been suggested that this depression of arginase activity interferes with deamination of amino acids, and thereby inhibits any increase in gluconeogenesis from protein and thus starves the mammary gland of non-nitrogenous milk precursors (Folley and Greenbaum, 1947, 1948). As there is little arginase in the mammary gland of other species (*e.g.*, rabbit, cow, goat, sheep), this mechanism may not have general validity (for further discussion see Folley, 1956). Other biochemical studies have suggested that the steroids of the adrenal cortex may be concerned in mammary lipogenesis, but the results so far have been conflicting and no firm conclusions can as yet be drawn (see Folley, 1956).

### C. OVARIAN HORMONES

There is no evidence that ovariectomy has any deleterious effect on lactation (Kuramitsu and Loeb, 1921; de Jongh, 1932; Folley and Kon, 1938; Flux, 1955); neither is there evidence for the belief, once

TABLE 10.1  
*Replacement therapy in lactating rats  
adrenalectomized on the fourth  
day of lactation*

(From A. T. Cowie and S. J. Folley,  
*J. Endocrinol.*, 5, 9-13, 1947.)

Treatment	Number of Litters	Number of Pups per Litter	Litter-growth Index* gm. + S.E.
Control	8	8	15.6 + 0.5
Adrenalectomy	9	8	7.5 ± 0.6
Adrenalectomy + cortisone + DCA (tablet implants†)	7	8	14.9 ± 0.6

(Above results from Cowie, 1952)

Control	6	8	14.5 ± 0.8
Adrenalectomy	6	8	6.2 ± 0.4
Adrenalectomy + chlorocortisol (100 µg per day)	5	8	13.1 ± 0.5

(Above results from Cowie and Tindal, 1955)

Control	8	12	17.7 ± 0.8
Adrenalectomy	8	12	7.5 ± 0.5
Adrenalectomy + ovariectomy	5	12	3.6 ± 0.5
Adrenalectomy + ovariectomy + fluorocortisol (200 µg per day)	7	12	14.5 ± 0.7

(Above results from Cowie and Tindal, unpublished)

\* The litter-growth index is defined as the mean daily gain in weight per litter over the 5-day period from the 6th to the 11th days.

† 2 × 11 mg. tablets cortisone giving mean daily absorption of 850 µg., and 1 × 50 mg. tablet DCA giving mean daily absorption of 360 µg.

widely held, that ovariectomy increases and prolongs lactation in the nonpregnant cow (see Richter, 1936).

Although the integrity of the ovary is not essential for the maintenance of lactation, there can be no doubt that ovarian hormones, in certain circumstances, profoundly influence milk secretion. Estrogens have long been regarded as possessing the power to inhibit lactation, a concept on which Nelson based his theory of the mechanism of lactation initiation (see page 606). Some workers, however, have expressed doubts that the effect is primarily on milk secretion, and have suggested that breast-

periments on laboratory animals the apparent failure in milk secretion could be a secondary effect due to either a toxic action of the estrogen causing an anorexia in the mother, interference with milk ejection, or disturbance of maternal behavior or to toxic effects on the young, whose growth rate serves as a measure of lactational performance, through estrogens being excreted in milk. The evidence to date shows that in

the intact rat estrogens even in very low doses inhibit milk secretion, their action depending on the presence of the ovary; the ovarian factor concerned appears to be progesterone, estrogen and progesterone acting locally on the mammary gland and rendering it refractory to the lactogenic complex. In the ovariectomized rat much larger doses of estrogen are necessary to inhibit lactation, and the evidence is not entirely

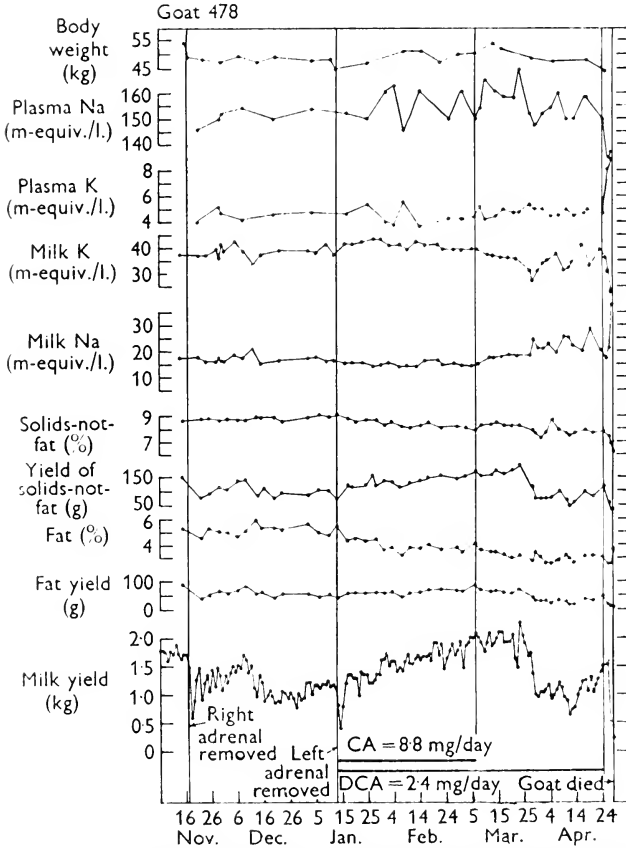

FIG. 10.12.1. Effect of replacement therapy with desoxycorticosterone acetate (DCA) and cortisone acetate (CA) on milk yield, milk composition, and concentration of Na and K in milk and blood plasma of the goat after adrenalectomy. Duration of replacement therapy (pellet implantation) indicated by horizontal lines; the names of steroids and their mean daily absorption rates are given adjacent to the lines. Note in Figure 12.1 the considerable maintenance of milk yield with DCA alone. See also Figure 12B. (From A. T. Cowie and J. S. Tindall, *J. Endocrinol.*, **16**, 403-414, 1958.)

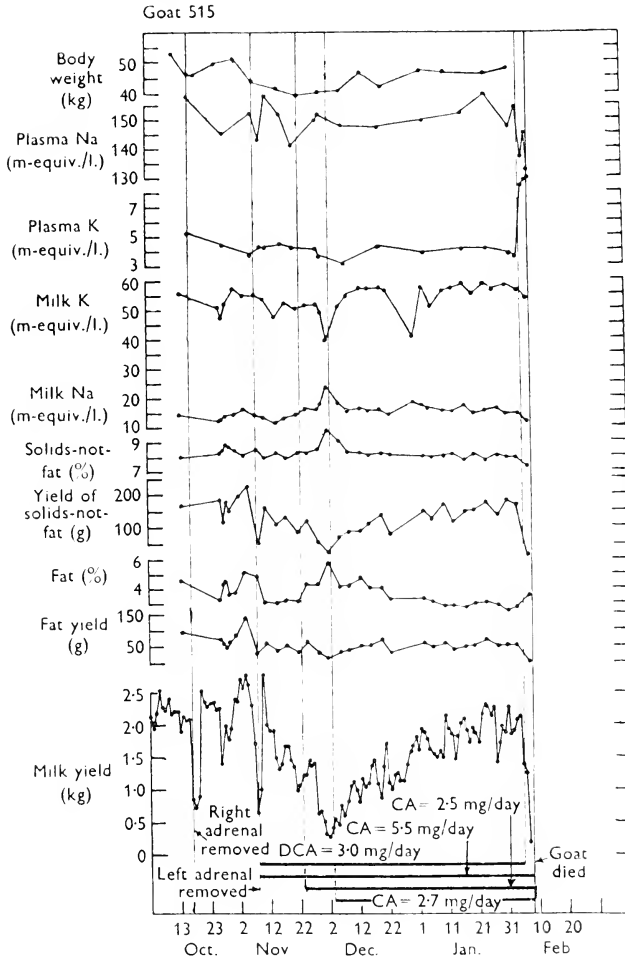

FIG. 12B.

conclusive that there is a true inhibition of milk secretion (see Cowie, 1960). In the cow estrogen in sufficient doses depresses milk yield, but its mode of action has not been fully elucidated. In women, estrogens are used clinically to suppress unwanted lactation, but as the suckling stimulus is also removed about the same time, the role of the estrogen is difficult to assess (see Meites and Turner, 1942a).

It has been well established that progesterone by itself has no effect on milk secretion (see Folley, 1952a), save in the adrenalectomized animal (see page 612), and so it would appear that the physiologic inhibition of lactation is effected by estrogen and progesterone acting synergistically as first demonstrated by Fauvet (1941b) and confirmed by others including Masson (1948), Walker and Matthews (1949),

Cowie, Folley, Malpress and Richardson (1952), and Meites and Sgouris (1954). There is clear evidence that the estrogen-progesterone combination acts at least partly on the mammary parenchyma (Desclin, 1952; Meites and Sgouris, 1953) but the mechanism of the action is unknown. The hormonal interplay and complex endocrine interactions in the process of lactation inhibition with estrogen has recently been discussed at length by von Berswordt-Wallrabe (1958).

Laetogenic effects of estrogens have already been mentioned; these have been demonstrated most strikingly in cows and goats, in which milk secretion has been induced in udders being developed by exogenous estrogen. These experiments have been reviewed in some detail by Folley and Malpress (1948b) and Folley (1956). It is generally assumed that estrogens act by

stimulating the production of laetogenic and galactopoietic factors by the anterior pituitary. In experiments on the ovariectomized goat we have shown (Cowie, Folley, Malpress and Richardson, 1952; Benson, Cowie, Cox, Flux and Folley, 1955) that it is possible to select a daily dose of estrogen which will induce mammary growth but relatively little secretion in the sense that the udder does not become tense and distended as will happen when a lower dose of estrogen is given—an observation we may quote in support of the "double-threshold" theory of estrogen action. The laetogenic effect of the lower dose of estrogen could be abolished, however, by administering progesterone simultaneously with the estrogen (Fig. 10.13), an observation in accord with those of other workers on the rabbit and rat (see above).

In 1936 one of us (Folley, 1936) reported

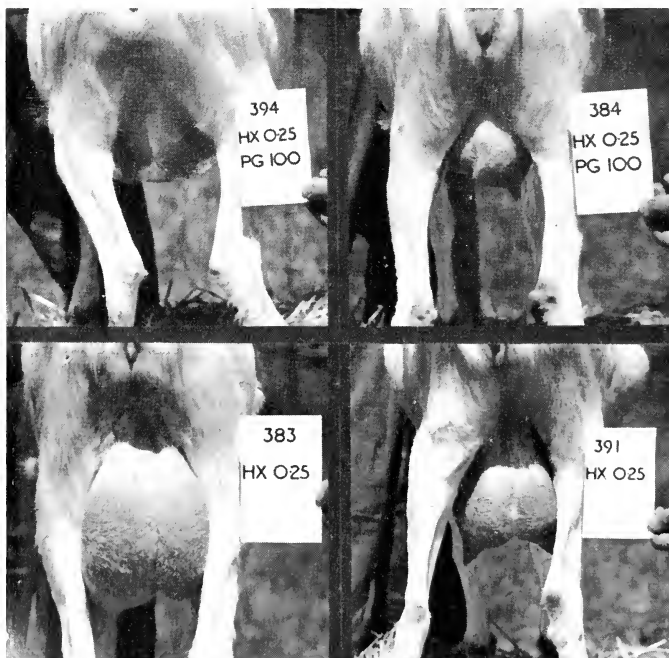

FIG. 10.13. Photographs of goat udders developed by daily injections of hexoestrol (HX) with and without progesterone (PG). The labels indicate the daily dose in mg. of each substance. (Results from A. T. Cowie, S. J. Folley, F. H. Malpress and K. C. Richardson, *J. Endocrinol.*, 3, 61-88, 1952.)

that certain dose levels of estrogen in the lactating cow produced long-lasting changes in milk composition characterized by increases in the percentages of fat and non-fatty solids. This was regarded as an example of galactopoiesis and was termed the "enrichment" effect. The effect, however, was somewhat erratic and it has recently been re-investigated by Hutton (1958) who confirmed and extended the earlier observations. Hutton found that galactopoietic responses (Figs. 10.14 and 10.15) were obtained only within a restricted dose range, the limits of which were affected by the stage of pregnancy and the breed of the cow. Hutton further concluded that in the normal cow changes in milk composition and yield associated with advancing pregnancy were probably determined by the progressive rise of blood estrogen levels.

#### D. THYROID HORMONES

Studies on the effect of removal of the thyroids on milk secretion have been reviewed by one of us (Folley, 1952a); the evidence strongly suggests that the thyroid glands are not essential for milk secretion, but in their absence the intensity and duration of lactation is reduced. Histologic and cytologic studies of the thyroid of the lactating cat suggest that there is a considerable outpouring of the thyroid secretion in the early stages of lactation (Racadot, 1957), and Grosvenor and Turner (1958b) have reported that the thyroid secretion rate is higher in lactating than in nonlactating rats.

Since the last edition of this book, a great volume of experimental results has been published on the use of thyroid-active materials for increasing the milk yield of cows. These experiments have been extensively reviewed by Blaxter (1952) and Meites (1960) and we need here only touch on the salient points.

In the early studies preparations of dried thyroid gland were fed to cows or injections of DL-thyroxine were given, but the use on a large scale of thyroid-active materials for increasing the milk yield of cows only became feasible when it was shown that certain iodinated proteins exhibited thyroid-like activity when given in the feed. Al-

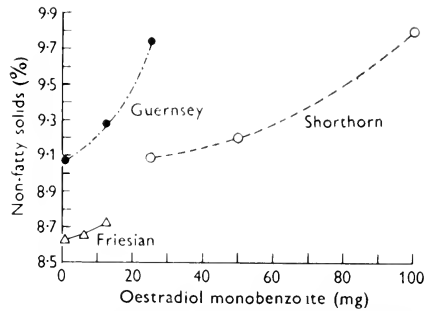

FIG. 10.14. Effect of graded doses of estradiol benzoate on percentage of nonfatty solids in milk from cows of three breeds. (From J. B. Hutton, *J. Endocrinol.*, **17**, 121-133, 1958.)

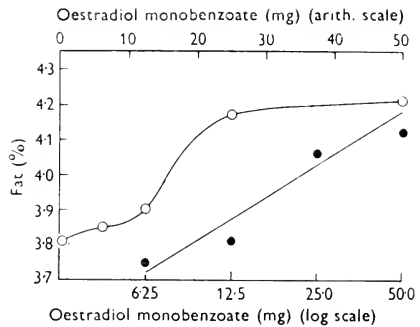

FIG. 10.15. Effect of graded doses of estradiol benzoate on fat content of cows' milk. *Upper curve*, doses plotted on arithmetic scale. *Lower curve*, doses plotted on logarithmic scale. (From J. B. Hutton, *J. Endocrinol.*, **17**, 121-133, 1958.)

though these materials were readily made and were economical for large-scale use, they possessed several disadvantages. Their activity was difficult to assay and standardize, they were frequently unpalatable, and their administration entailed a considerable intake of iodine which could be undesirable. Nevertheless, a large number of experiments were carried out all over the world with this type of material. In 1949, however, a new and improved method for the synthesis of L-thyroxine was developed (Chalmers-Dickson, Elks and Hems, 1949) and thyroxine became available in large quantities. It was then shown by Bailey, Bartlett and Folley (1949) that this material was galac-

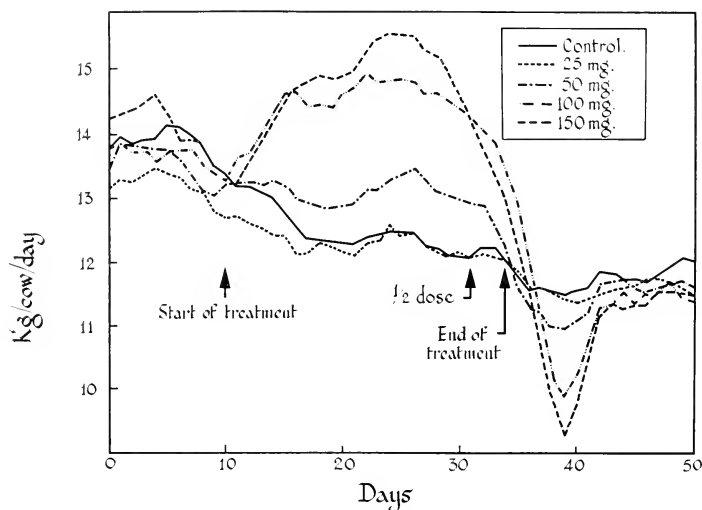

FIG. 10.16. Effect of L-thyroxine given in the feed on the milk yield of groups of cows (the indicated dose levels were fed daily). (From G. L. Bailey, S. Bartlett and S. J. Folley, *Nature*, London, **163**, 800, 1949.)

topoietic when fed to lactating cows in daily doses of about 100 mg. (Fig. 10.16). It had, moreover, none of the drawbacks of the iodinated proteins, its purity could be checked chemically, it was odorless and tasteless. With the introduction of synthetic thyroxine, iodinated proteins have become obsolete as galactopoietic agents.

The more recently isolated 3:5:3-tri-iodo-L-thyronine, reported to be 5 to 7 times more active than thyroxine in various biologic tests in small animals and also in man, has little or no effect on the milk yield when fed to cows, but is somewhat more active than thyroxine in promoting galactopoiesis when administered subcutaneously, which suggests that the material is inactivated in the gut, probably in the rumen (Bartlett, Burt, Folley and Rowland, 1954).

The extensive experiments on galactopoiesis in dairy cattle with thyroxine and thyroid-active substances have made it possible to reach reasonably firm conclusions as to the practical value of the procedure. There is great variability in the response to treatment; in general a better response is obtained during the decline of lactation than at the peak and end of lactation. The use of thyroid-active substances

in animals undergoing their first, second, or third lactation is of doubtful benefit because the boost in yield is largely cancelled out by a shortening of the lactation period. Short-term administration at suitable times can result in considerable galactopoiesis, but this is frequently followed by marked falls in yield when the administration of thyroid-active material ends. The administration of thyroid-active materials to dairy cows, if carried out with due care, has no ill effects on the health and reproductive abilities of the cows (see Leech and Bailey, 1953), but because of the rather small net gain in yield (about 3 per cent) the practical application of the procedure seems to be limited.

The mode of action of thyroxine and thyroid-active substances on milk secretion is uncertain. It is unlikely that it is a specific effect on the alveolar cells; rather it is probably related to the effects of the thyroid hormone on the general metabolic rate.

#### E. PARATHYROID HORMONE

The early studies on the influence of the parathyroid glands on milk secretion indicated, as might be expected from their

role in calcium metabolism, that the parathyroids were important in the maintenance of secretion (see review by Folley, 1952a). Indeed in the rat, we demonstrated that the severe impairment of milk secretion previously observed in "thyroidectomized" rats was due not to the removal of the thyroids, but to the simultaneous ablation of the parathyroids (Cowie and Folley, 1945). This observation has since been confirmed and extended by Munson and his colleagues (Munson, 1955) who demonstrated an influence on the calcium-concentrating mechanism of the mammary glands. Within 24 hours of parathyroidectomy the concentration of calcium in the milk of the lactating rat was increased markedly despite a greatly depressed level of calcium in the serum; there was also a decrease in water content of the milk, but this did not entirely account for the increase in calcium content since the calcium content expressed as mg. per gm. milk solids was significantly higher after parathyroidectomy (Toverud and Munson, 1956). Further studies in this field are awaited with interest.

#### F. INSULIN

Early experiments (see review by Folley, 1952a) indicated that the endocrine pancreas might influence mammary function in two ways; indirectly by way of the general intermediary metabolism by which the supply of milk precursors may be regulated, and directly through its role in the carbohydrate metabolism of the mammary gland itself.

Most recent studies have been concerned with the effect of insulin on mammary tissue *in vitro*. Mammary gland slices from lactating rats actively synthesize fat from small molecules, glucose, and glucose plus acetate, but not from acetate alone (Folley and French, 1950). The addition of insulin to the incubation medium very markedly increases the R.Q. (see Table 10.2) and glucose uptake of the tissue slices and experiments with isotopes show that the rate of fat synthesis is increased (Balmain, Folley and Glascock, 1952). Mammary gland slices from lactating sheep, on the other hand, can utilize acetate alone but not glucose alone for fat synthesis (Folley and French, 1950) and sheep tissue is not re-

TABLE 10.2  
*Effect of different substrates and of insulin on the respiratory quotient (R.Q.) of lactating mammary gland slices from various species*

(From S. J. Folley and M. L. McNaught, Brit. M. Bull., 14, 207-211, 1958.)

Animal	Substrate	Respiratory Quotients	
		Without insulin	With insulin
Mouse	Glucose	1.90	2.14
	Glucose + acetate	1.46	2.14
Rat	Glucose	1.57	1.80
	Acetate	0.82	—
	Glucose + acetate	1.53	2.03
Guinea pig	Glucose	1.17	—
Rabbit	Glucose	1.30	—
	Acetate	0.92	—
	Glucose + acetate	1.24	1.67
Sheep	Glucose	0.88	—
	Acetate	1.09	1.09
	Glucose + acetate	1.52	1.50
Goat	Glucose	0.86	—
	Acetate	1.17	—
Cow	Glucose	0.84	—
	Acetate	1.12	—

sponsive to insulin *in vitro*. This clear-cut species difference is interesting and underlines the need for further study. It is of passing interest to note that the response *in vitro* of rat mammary tissue to insulin has been made the basis of a highly specific *in vitro* bio-assay for insulin (Fig. 10.17) (Balmain, Cox, Folley and McNaught, 1954; McNaught, 1958).

Further references and discussion on the role of insulin in mammary function and lipogenesis will be found in the reviews by Folley (1956), and Folley and McNaught (1958, 1960).

### IV. Removal of Milk from the Mammary Glands: Physiology of Suckling and Milking

#### A. MILK-EJECTION REFLEX

Since the second edition of this book there have been major advances in our knowledge of the physiology of milk removal. In the mammary gland the greater

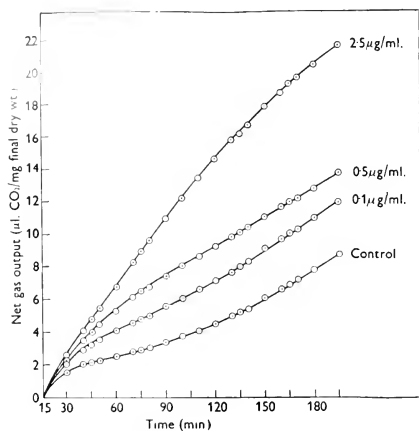

FIG. 10.17. Effect of various concentrations of insulin on the respiratory metabolism of slices of rat mammary glands. (From J. H. Balmain, C. P. Cox, S. J. Folley and M. L. McNaught, *J. Endocrinol.*, **11**, 269-276, 1954.)

portion of the milk secreted by the alveolar cells in the intervals between suckling or milking remains within the alveoli and the fine ducts. Only a small portion passes into the larger ducts and cisterns or sinuses from which it can be *immediately* removed by suckling, milking, or cannulation; its removal requires no maternal participation and has been termed *passive withdrawal* (see Cowie, Folley, Cross, Harris, Jacobsohn and Richardson, 1951, and page 612). The larger portion of the milk in the alveoli and fine ducts becomes available only with the active participation of the mother and requires the reflex contraction of special cells (see page 623) surrounding the alveoli in response to the milking or suckling stimulus to eject the milk from the alveoli and fine ducts into the cistern and sinuses of the gland. The occurrence of this reflex has long been known, although its true nature has only recently been generally recognized.<sup>2</sup>

<sup>2</sup>H. K. Waller (*Clinical Studies on Lactation*, London: Heinemann, 1938), and later one of us (S. J. Folley, *Physiology and Biochemistry of Lactation*, London and Edinburgh: Oliver & Boyd, 1956) have drawn attention to the fact that the theme of the "milk-ejection reflex" was the inspiration of a painting by Il Tintoretto entitled "The Origin of the Milky Way" which hangs in the

In the past it has been termed the "draught" in lactating women (see Isbister, 1954) and the "let-down" of milk in the cow. The latter term is particularly misleading since it implies the release of some restraint, whereas there is, in fact, an active and forceful expulsion of milk from the alveoli and we have, therefore, urged that this term be no longer used in scientific literature and that it be replaced by the term "milk ejection" (Folley, 1947; Cowie, Folley, Cross, Harris, Jacobsohn and Richardson, 1951), a term, incidentally, which was used by Gaines in 1915 in his classical researches on the phenomenon (see below).

The true nature of the milk removal process was for many years not recognized, probably because it was assumed that the mammary gland could not contain all the milk obtainable at a milking, and this assumption made it necessary to postulate a very active secretion of milk during suckling or milking. Even as late as 1926 two phases of milk secretion were described in the cow; the first phase was one of slow secretion occurring between milkings, the second phase was one of very active secretion occurring in response to the milking stimulus when a volume of milk about equal to that produced in the first phase was secreted in a matter of a few minutes (Zietzschmann, 1926). That some physiologic mechanism

National Gallery, London. Both authors point out that the picture shows evidence of a considerable intuitive understanding of the physiologic nature of the milk-ejection reflex. Thus, it illustrates, first, that the application of the suckling stimulus causes a considerable increase in intramammary pressure resulting, in this instance, in a spurt of milk from the nipples, and second, that the suckling stimulus applied to one nipple gives rise to a systemic rather than a localized effect, for the milk is forcibly ejected from the suckled and unsuckled breasts alike. The same theme was also treated by Rubens in a picture called "The Birth of the Milky Way" which can be seen in the Prado Museum, Madrid. This picture differs from Tintoretto's in one important detail, the stream of milk coming only from one breast.

The forcible ejection of milk from the nipple has doubtless been the subject of many statues. An example known to the authors is the fountain in the Square at Palos Verdes, near Los Angeles, California. The center piece of this fountain has a nude female torso at each of its four corners from whose nipples spurt streams of water.



was involved in the discharge of preformed milk from the mammary gland had, however, been recognized. Schäfer (1898) considered that milk discharge was aided by contraction of plain muscle within the gland and pressure on the alveoli produced by vasodilation.

The first full investigation of the physiology of milk removal was that by Gaines in 1915. Unfortunately, his remarkably accurate observations and perspicacious conclusions aroused little general interest and were almost wholly overlooked for more than quarter of a century. It is now of interest to recall the more important of Gaines' observations. First, he made a clear distinction between milk ejection and milk secretion—"Milk secretion, in the sense of the formation of the milk constituents, is one thing; the ejection of the milk from the gland after it is formed is quite another thing. The one is probably continuous; the other, certainly discontinuous." Secondly, he concluded that "Nursing, milking and the insertion of a cannula in the teat, excite a reflex contraction of the gland musculature and expression of milk. There is a latent period of 35 to 65 seconds. . . . Removal of milk from the gland is dependent on this reflex, and it may be completely inhibited by anaesthesia. The conduction in the reflex arc is dependent upon the psychic condition of the mother." He also observed that the increased flow of milk following the latent period after stimulation was associated with a steep rise in pressure within the gland cistern and that the reflex could be conditioned. Thirdly, with reference to the gland capacity, he reported that "the indication is that practically the entire quantity of milk obtained at any one time is present as such in the udder at the beginning of milking." Lastly, he confirmed earlier observations that injections of posterior pituitary extract caused a flow of milk in the lactating animal and he postulated that "pituotrin has a muscular action on the active mammary gland causing a constriction of the milk ducts and alveoli with a consequent expression of milk. This action holds, also, on the excised gland in the absence of any true secretory action." Gaines regarded the milk-ejection reflex as a

purely neural arc although he emphasized that the effect was "very similar to that produced by pituitrin." All that is required to bring these views of milk ejection in line with present day concepts is to recognize that the reflex arc is neurohormonal in character, the efferent component of which is a hormone released from the neurohypophysis. When Gaines was carrying out these experiments hardly anything was known of neuro-endocrine relationships and there was no background of knowledge to lead anyone to conceive that the effects of the posterior pituitary extract might represent a physiologic rather than a pharmacologic effect. In 1930 Turner and Slaughter hinted at a possible physiologic role of the posterior pituitary in milk ejection and, as we have noted (page 610), Gomez (1939) used posterior pituitary extract in replacement therapy given to hypophysectomized lactating rats. It was not until 1941, however, that the role of the posterior pituitary in milk ejection was seriously postulated by Ely and Petersen (1941) who, having shown in the cow that milk ejection occurred in the mammary gland to which all efferent nerve fibers had been cut, suggested that the reflex was neurohormonal, the hormonal component being derived from the posterior pituitary, and being, in all likelihood, oxytocin. The neurohormonal theory of Ely and Petersen and the subsequent work of Petersen and his colleagues (see reviews by Petersen, 1948; and Harris, 1958), unlike the earlier work of Gaines, aroused wide interest and its practical applications permitted rationalization of milking techniques in the cowshed thereby improving milk yields. Despite the attractiveness of the concept, however, a further 10 years were to elapse before unequivocal evidence of the correctness of the theory was forthcoming and this evidence we shall now briefly review.

#### B. ROLE OF THE NEUROHYPOPHYSIS

The first reliable indication that the suckling or milking stimulus does in fact cause an outpouring of neurohypophysial hormones were the observations that inhibition of diuresis occurred following application of the milking or suckling stimulus (Cross, 1950; Peeters and Cous-

sens, 1950; Kalliala and Karvonen, 1951; Kalliala, Karvonen and Leppanen, 1952). It was also shown that electrical stimulation of the nerve paths to the posterior pituitary resulted in milk ejection (Cross and Harris, 1950, 1952; Andersson, 1951a, b, c; Popovich, 1958), and that when lesions were placed in these tracts the milk-ejection reflex was abolished (Cross and Harris, 1952).

Further evidence was adduced when it was found that removal of the posterior pituitary immediately abolished the milk-ejection reflex in the lactating rat, and that it was necessary to inject such animals several times a day with oxytocin if their litters were to be reared (Cowie, quoted by Folley, 1952b). Earlier workers had claimed that the posterior lobe was not essential for lactation (Smith, 1932; Houssay, 1935), but an explanation of these discordant conclusions was provided when it was shown that the impairment of the reflex after removal of the posterior lobe is not permanent and that the reflex re-establishes itself after some weeks, presumably because the remaining portions of the neurohypophysis take over the functions of the posterior lobe (Benson and Cowie, 1956). That the neurohypophysis participates in milk ejection would now appear to be beyond question.

The discovery of the role of the neurohypophysial hormones in milk ejection has provided an explanation of some longstanding clinical observations on what has been termed the natural "sympathy" between the uterus and the breasts. Thus the beneficial effects of the suckling stimulus and the occurrence of the "draught" (*i.e.*, milk ejection) in causing uterine contraction after parturition were emphasized over a century ago by both Smith (1844) and Paterson (1844). Observations have also been made on the reciprocal process of stimuli arising from the reproductive organs apparently causing milk ejection. In domestic animals two such examples were mentioned by Martiny (1871). According to Herodotus, the Scythians milk their mares thus: "They take blowpipes of bone, very like flutes, and put them into the genitals of the mares and blow with their mouths, others milk. And they say that the reason why they do so is this, that when the mare's veins are filled

with air, the udder cometh down" (translation by Powell, 1949). Kolbe (1727) described a similar procedure of blowing air into the vagina used by the Hottentots when milking cows which were normally suckled by calves and in which, presumably, milk ejection did not occur in response to hand milking. A drawing depicting this procedure from Kolbe's book was recently published in the *Ciba Zeitschrift* (No. 84, 1957) along with a photograph of African natives still using the method!<sup>3</sup>

In 1839, Busch described the occurrence of milk ejection, the milk actually spurting from the nipple, in a lactating woman during coitus. A satisfactory explanation of these curious observations is now forthcoming. Harris (1947) suggested that coitus might cause the liberation of oxytocin from the neurohypophysis and, within the next few years it was demonstrated that stimulation of the reproductive organs evoked milk ejection in the cow (Hays and VanDemark, 1953) and reports confirmatory of Busch's long forgotten observations also appeared (Harris and Pickles, 1953; Campbell and Petersen, 1953).<sup>4</sup>

#### C. MILK-EJECTION HORMONE

There is much circumstantial evidence to confirm the belief that the milk-ejection hormone is oxytocin (see Cowie and Folley, 1957). Attempts, however, to demonstrate oxytocin in the blood after application of the milking stimulus have given rather inconclusive results. Early claims that the hormone could be demonstrated in blood are

<sup>3</sup> A similar drawing, also apparently from Kolbe's book, has been used in the campaign for clean milk production! Heineman (1919) discussing sanitary precautions in the cowshed says of the picture "another picture shows a nude Hottentot milking a cow while another one is holding the tail of the cow to prevent its dropping into the open pail. This picture might well serve as a model to some modern producers who do not take such precautions and calmly lift the tail out of the milk with their hands when it happens to switch into the pail."

<sup>4</sup> We have been able to find only one painting illustrating this phenomenon. It is a picture by a contemporary French painter, André Masson, entitled "Le Viol" and painted in 1939. It illustrates in Masson's personal idiom the act of rape and it is interesting to note that a stream of milk is depicted as being forcibly ejected from one breast of the victim.

of doubtful validity, because the milk-ejection effect observed may have been due to 5-hydroxytryptamine (see Linzell, 1955), and more recent attempts to assay the level of oxytocin in the blood have not been entirely satisfactory or conclusive. There seem to be other polypeptide substances in blood which possess oxytocic activity, although the thioglycollate inactivation test indicates that these are different from oxytocin (Robertson and Hawker, 1957), and no marked changes in the blood oxytocic activity associated with suckling or milking have been detected (Hawker and Roberts, 1957; Hawker, 1958). However, it would seem doubtful whether the present assay techniques are sufficiently sensitive and specific to detect changes in blood oxytocin of the magnitude likely to be associated with milking or suckling. In the lactating cow the intravenous injection of 0.05 to 2.0 I.U. oxytocin will cause milk ejection (Bílek and Janovský, 1956; Donker, 1958), in the goat 0.01 to 1 I.U. (Cowie, cited by Folley, 1952b); Denamur and Martinet, 1953), in the sow 0.2 to 1.0 I.U. (Braude, 1954; Whittestone, 1954; Cross, Goodwin and Silver, 1958) in the rabbit 0.05 I.U. (Cross, 1955b), and in the lactating woman 0.01 I.U. (Beller, Krumholz and Zeininger, 1958). If these doses give any indication of the quantity of endogenous oxytocin released, then the concentration in the peripheral blood is likely to be very small; indeed Cross, Goodwin and Silver (1958) calculated that a threshold dose (10 mU.) of oxytocin in the sow would give a plasma concentration of about  $1 \mu\text{U.}$  per ml., and until it can be shown that the assay techniques are sufficiently sensitive to detect the changes in oxytocin concentration produced by intravenous injections of "physiologic" doses of oxytocin, no great reliance can be placed on the results of assays.

Attempts have been made to demonstrate alterations in the hormone content of the neural lobe following the suckling or milking stimulus. In the goat and cow no detectable changes have been reported, but in the smaller species (dog, cat, rat, guinea pig) decreases have been described (see Cowie and Folley, 1957). It is likely that in many species the amount released is small

relative to the total hormone content of the gland and within the limits of error of the assay.

#### D. EFFECTOR CONTRACTILE MECHANISM OF THE MAMMARY GLAND

In the last 10 years considerable research has been devoted to a study of the effector contractile tissue in the mammary gland; this work has recently been reviewed in some detail (see Folley, 1956) and only the salient features need be mentioned here.

Although earlier histologists had from time to time figured myoepithelial or "basket" cells in close association with the mammary alveoli, the morphology and distribution of the cells remained vague until Richardson (1949) published a detailed and illuminating description (Fig. 10.18). His beautiful observations have since been confirmed and supplemented by Linzell (1952) and Silver (1954). Richardson also disposed of the oft repeated view that smooth-muscle fibers around the alveoli played an important role in milk ejection. From a study of the general orientation of the myoepithelial cells and the precise relationship between these cells and the folds in the secretory epithelium from contracted glands, Richardson considered it reasonable to regard the myoepithelium as the contractile tissue in the mammary gland which responds to oxytocin causing contraction of the alveoli and widening of the ducts. The evidence adduced by Richardson, although good, was nevertheless circumstantial, and it was desirable that attempts be made to visualize the contraction of the myoepithelial cells in response to oxytocin. In this connection it is of interest to recall that Gaines (1915) reported that when a drop of pituitrin was placed on the cut surface of the mammary gland from a lactating guinea pig, minute white dots appeared within a few seconds beneath the pituitrin and slowly swelled to tiny milky rivulets streaming beautifully through the clear liquid. Much later the local effects of posterior pituitary extract on the mammary gland were studied by Zaks (1951) in the living mouse, when it was reported that it caused contraction of the alveoli and expansion of the ducts. These observations were considerably extended by Linzell



FIG. 10.18. Surface view of contracted alveoli (of goat) showing myoepithelial cells. (Courtesy of K. C. Richardson.)

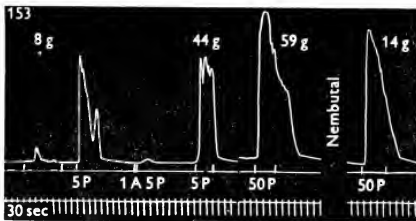

FIG. 10.19. Recording of pressure changes within a galactophore of a forcibly restrained lactating rabbit. The litter was allowed to suckle the non-cannulated mammary glands but obtained only 8 gm. milk, there being only a slight rise in the milk pressure probably associated with a slight contraction of the myoepithelium in response to mechanical stimulation. When 5 mU. oxytocin were injected (5P) there was a rapid milk ejection response which could be inhibited by injecting 1 µg. adrenaline (1A) just before the oxytocin. After a few minutes 5 mU. oxytocin were again effective and the litter obtained 44 gm. milk when they were allowed to suckle. A more complete milk ejection response was obtained with 50 mU. oxytocin (50P) and the young obtained a further 59 gm. milk. Anesthesia did not enhance the milk-ejection response to 50 mU. oxytocin. During emotional inhibition of milk ejection the mammary gland thus remains responsive to oxytocin. (From B. A. Cross, *J. Endocrinol.*, 12, 29-37, 1955.)

(1955) who studied the local effects of highly purified oxytocin and vasopressin and a number of other drugs on the mammary gland, and confirmed that oxytocin and vasopressin produced alveolar contraction and widening of the ducts. Although in these experiments the myoepithelial cells themselves could not be visualized, nevertheless the effects observed leave little doubt that the effector mechanism was the myoepithelium.

The myoepithelium is responsive to stimuli other than those arising from the presence of neurohypophysial hormones in the blood inasmuch as partial milk ejection may occur in response to local mechanical stimulation of the mammary gland (Cross, 1954; Yokoyama, 1956; see also Fig. 10.19). These observations may explain the recent reports by Tverskoï (1958) and Denamur and Martinet (1959a, b) that milk yields can be maintained in goats in the absence of the milk-ejection reflex.

#### E. INHIBITION OF MILK EJECTION

Gaines (1915) stressed that the conduction in the milk-ejection reflex pathway was dependent on the psychic condition of the

mother. Many years later Ely and Petersen (1941) confirmed this and, having shown that injections of adrenaline blocked the milk-ejection reflex, postulated that the increased blood level of adrenaline in emotionally disturbed cows interfered with the action of oxytocin. In the last few years, the nature of the inhibitory mechanisms has been more fully investigated. Braude and Mitchell (1952) showed in the sow that adrenaline exerts at least part of its inhibitory effect at the level of the mammary gland and that, whereas the injection of adrenaline before the injection of oxytocin blocked milk ejection, less inhibition occurred if both were given together. Cross (1953, 1955a) confirmed these observations in the rabbit and demonstrated that electrical stimulation of the posterior hypothalamus (sympathetic centers) inhibited the milk-ejection response to injected oxytocin, an effect which was abolished after adrenalectomy. Cross concluded from his experiments that any central stimulation causing sympathetico-adrenal activity inhibits the milk-ejection response and that the effect appears to depend on a constriction of the mammary blood vessels resulting from the release of adrenaline and excitation of the sympathetic fibers to the mammary glands. Whereas such a mechanism could account for the emotional disturbance of the reflex, Cross was careful to point out that there was no direct proof that this was so and he later demonstrated (Cross, 1955b) that in rabbits in which emotional inhibition of milk ejection was present, milk ejection could be effected by the injection of oxytocin (Fig. 10,19). In such cases there was clearly no peripheral inhibitory effect of milk ejection. Cross concluded that the main factor in emotional disturbance of the milk-ejection reflex is a partial or complete inhibition of oxytocin release from the posterior pituitary gland. At present nothing is known of the nature of this central inhibitory mechanism.<sup>5</sup>

<sup>5</sup>A curious form of the suckling stimulus is illustrated in carvings which surmount the main door of the church of Sainte Croix in Bordeaux. The carvings illustrate penances prescribed for wrong doers who have committed one of the seven deadly sins. The penance for indulgence in the sin of luxury is the application to the breasts of serpents or toads.

Inhibition of the milk ejection reflex may also occur when the mammary gland becomes engorged with secretion to such an extent that the capillary circulation is so reduced that oxytocin can no longer reach the myoepithelium (Cross and Silver, 1956; Cross, Goodwin and Silver, 1958).

#### F. NEURAL PATHWAYS OF THE MILK-EJECTION REFLEX

Interpretation of some of the earlier studies on neural pathways is difficult because investigators did not realize that, although the milk ejection reflex normally occurs in response to the suckling stimulus, it can become conditioned and can then occur in response to visual or auditory stimuli associated with the act of nursing. In such cases an apparent lack of effect on milk ejection of section of nerves or nerve tracts would not necessarily imply that the nerves normally carrying the stimuli arising from the suckling had not been cut. Studies on the effects of hemisection of the spinal cord in a few goats led Tsakhaev (1953) to the conclusion that the apparent pathway used by the milk-ejection stimulus was uncrossed. More recently pathways within the spinal cord have been investigated by Eayrs and Baddeley (1956) who found *inter alia* that lactation in the rat was inhibited by lesions to the lateral funiculi, and by section of the dorsal roots of nerves supplying the segments in which the suckled nipples were situated. With few exceptions hemisection of the spinal cord abolished lactation when the only nipples available for suckling were on the same side as the lesion, but not when the contralateral nipples were available. It was concluded that the pathway used by the suckling stimulus enters the central nervous system by the dorsal routes and ascends the cord deep in the lateral funiculus of the same side. Inasmuch as in these experiments lactation was assessed from the growth curve of the pups, it is not always clear whether the failure of lactation was due to a cessation of milk secretion or to loss of the milk-ejection reflex. It was noted, however, that injections of oxytocin in some

It may be questioned whether this unusual form of the suckling stimulus would not inhibit rather than evoke the milk-ejection reflex.

cases restored lactation for up to 2 days after it had ceased as a result of lesions of the cord which would suggest a primary interference with milk ejection. In the goat, Andersson (1951b) considered that stimuli may reach the hypothalamus by way of the medial lemniscus in the medulla, but little definite information is available concerning the pathways used by the stimuli to reach the hypothalamus and there is here scope for further investigations. (For further discussion see review by Cross, 1960.) From the hypothalamus there is little doubt that the route to the posterior lobe is by way of the hypothalamo-hypophyseal tract which receives nerve fibers from the cells in the hypothalamic nuclei, and in the main from the paraventricular and supra-optic nuclei. It was generally assumed that the posterior lobe hormones were secreted in the posterior lobe from the pituicytes in response to stimuli passing down the hypothalamo-hypophyseal tract. In the last decade, however, much evidence has come to light which suggests that the so-called posterior lobe hormones are in fact elaborated in the cells of the hypothalamic nuclei and are then transported down the axones as a neurosecretion and stored in the posterior lobe (see Scharrer and Scharrer, 1954).

Before leaving the neural pathways of the milk-ejection reflex, brief reference must be made to the recent discovery by Soviet physiologists that there is also a purely nervous reflex (segmental in nature) involved in the ejection of milk. It is said that within a few seconds of the application of the milking stimulus, reflex contraction of the smooth muscle in the mammary ducts occurs, causing a flow of milk from the ducts into the cistern. This reflex contraction of the smooth muscle is also believed to occur in response to stimuli arising within the gland between milkings thus aiding the redistribution of milk in the udder. This purely nervous reflex is stated to occur some 30 to 60 seconds before the reflex ejection of milk from the alveoli by oxytocin (for further details see review by Baryshnikov, 1957). The conditioned reflexes associated with suckling and milking have been the subject of numerous investigations by Grachev (see Grachev,

1953, 1958); these and other Russian researches into the motor apparatus of the udder have been fully reviewed by Zaks (1958).

#### G. MECHANISM OF SUCKLING

In the past, various theories have been put forward as to how the suckling obtains milk from its mother's mammary gland. In the human infant some considered that the lips formed an airtight seal around the nipple and areola thus allowing the child to suck, whereas others believed that compression of the lacteal sinuses between the gums aided the expulsion of the milk (see Ardran, Kemp and Lind, 1958a, b for review). In the calf the act of suckling was studied by Krzywaneck and Brüggemann (1930) who described how the base of the teat was pinched off between upper and lower jaws and the teat compressed from its base towards its tip by a stripping action of the tongue. Smith and Petersen (1945) on the other hand, concluded that the calf wrapped its tongue round the teat and obtained milk by suction.

Much misunderstanding about the nature of the act of suckling has arisen because the occurrence of milk ejection was overlooked or its significance was not appreciated. As a result, the idea became prevalent that success or failure in obtaining milk could be reckoned solely in terms of the power behind the baby's suction. This erroneous concept was vigorously attacked by Waller (1938), who pointed out that once the "draught" had occurred the milk at times flowed so freely from the breast that the baby had to break off and turn its head to avoid choking. A similar observation had been made by Sir Astley Cooper in 1840 who in describing the "draught" in nursing women wrote, "If the nipple be not immediately caught by the child, the milk escapes from it, and the child when it receives the nipple is almost choked by the rapid and abundant flow of the fluid; if it lets go its hold, the milk spurts into the infant's eyes." An even earlier comment was made by Soranus, a writer on paediatrics in the early half of the second century A.D., that it was unwise to allow the infant to fall asleep at the breast since the milk some-

times flowed without suckling and the infant choked. It must thus be emphasized that once milk ejection has occurred the milk in the gland cisterns or sinuses is under considerable pressure and the suckling has merely to overcome the resistance of the sphincters in the nipple or teat to obtain the milk.

Recently the use of cineradiography has allowed a more accurate analysis of the mechanism of suckling. Studies by Ardran, Kemp and Lind (1958b) have shown that the human infant sucks the nipple to the back of the mouth and forms a "teat" from the mother's breast; when the jaw is raised this teat is compressed between the upper gum and the tip of the tongue resting on the lower gum, the tongue is then applied to the lower surface of the "teat" from before backwards pressing it against the hard palate. Suction may assist the flow of milk so expressed from the nipple, but is only of secondary importance. Studies by Ardran, Cowie and Kemp (1957, 1958) in the goat have extended these observations, because it was possible in this species to follow the withdrawal, from the udder, of milk made radiopaque with barium sulfate. As with the infant, the neck of the teat was obliterated between the tongue and the palate of the kid and the contents of the teat sinus were displaced into the mouth cavity by a suitable movement of the tongue; while the first mouthful was being displaced into the pharynx, the jaw and tongue were lowered to allow the refilling of the teat sinus. The normal method of obtaining milk is, therefore, for the suckling to occlude the neck of the teat and then to expel the contents of the teat sinus by exerting positive pressure on the teat (120 mm. Hg in the goat), so forcing the contents through the teat canal or nipple orifices into the mouth cavity, a process which may be aided by negative pressure created at the tip of the teat. Human infants, goat kids, and calves can obtain milk through rubber teats by suction alone provided the orifice is large enough (see Krzywanek and Brüggemann, 1930; Martuyugin, 1944; Ardran, Kemp and Lind, 1958a), but this procedure occurs only when the structure of the rubber teat is such that the suckling is unable to obliterate the

neck of the teat and cannot, therefore, strip the contents of the teat by positive pressure.

#### **V. Relation between the Reflexes Concerned in the Maintenance of Milk Secretion and Milk Ejection**

We have seen that the suckling or milking stimulus is responsible for initiating the reflex concerned with the maintenance of milk secretion and also the milk-ejection reflex; the question now arises as to what extent their arcs share common paths. It would seem logical to assume that a common path to the hypothalamus exists and parts of this, as we have seen, have been partially elucidated. Although the hypothalamo-hypophyseal nerve tracts provide an obvious link between hypothalamus and the posterior lobe, the connections between the hypothalamus and anterior pituitary are still a matter of some controversy. The possible avenues of communication to the anterior lobe are neural and vascular and these may be subdivided into central and peripheral neural connections and into portal and systemic vascular connections. The various experimental findings relating to these routes have recently been critically discussed by Sayers, Redgate and Royce (1958), and by Greep and Everett in their chapters in this book, and it is clear that at present no definite conclusions can be reached concerning their relative importance. So far as the specific question of maintenance of milk secretion is concerned, the experiments of Harris and Jacobsen (1952), which showed that pituitary grafts maintained lactation when implanted adjacent to the median eminence in hypophysectomized rats, were consistent with the existence of a hormonal transmitter, passing by way of the hypophyseal portal system. On the other hand, transplantation studies by Deslin (1950, 1956) and Everett (1954, 1956) have revealed that in the rat the anterior lobe can spontaneously secrete prolactin in situations remote from the median eminence, and Donovan and van der Werff ten Bosch (1957) have reported that milk secretion continued in rabbits in which the pituitary portal vessels had been completely destroyed, although there was, however, an inferred change in milk composition. Evidence has recently been obtained

which has confirmed that pituitary tissue grafted under the kidney capsule in rats apparently secretes prolactin and will give slight maintenance of milk secretion in hypophysectomized animals, this maintenance being considerably enhanced if ACTH or STH is also administered (Cowie, Tindal and Benson, 1960). It would thus seem that the cells of the anterior lobe have the ability when isolated from the hypophyseal portal system to secrete prolactin, but the experiments cited above allow no conclusions to be drawn regarding the route by which the galactopoietic function of the pituitary is normally controlled.

Recent reports that bilateral cervical sympathectomy in the lactating goat causes a fall in the milk yield suggest that the galactopoietic functions of the anterior lobe may be influenced by the sympathetic nervous system (Tsakhaev, 1959; Tverskoy, 1960). Declines in milk yield also occur after section of the pituitary stalk in the goat, but it is not clear in such cases whether the effects are due to the interruption of nervous or vascular pathways within the stalk (Tsakhaev, 1959; Tverskoy, 1960). In these studies on stalk section the cut ends of the pituitary stalk were not separated by a plastic plate, so some restoration of the hypophyseal portal system may have occurred. Further experiments on the effects of section of the pituitary stalk on lactation in which restoration of the hypophyseal portal is prevented by the insertion of a plate are being conducted in our laboratory and also in the Soviet Union. Another possible mode of communication between hypothalamus and anterior pituitary has been investigated by Benson and Folley (1956, 1957a, b) who have suggested that the oxytocin released from the neurohypophysis in response to the suckling stimulus may directly act on the cells of the anterior lobe and stimulate the release of the galactopoietic complex. The careful anatomic researches of Landsmeer (1951), Daniel and Prichard (1956, 1957, 1958) and Jewell (1956) have demonstrated in several species the existence of direct vascular connections from the neurohypophysis to the anterior lobe so that the neurohypophysial hormones liberated into the blood stream would in fact be carried

direct to the anterior pituitary cells in very high concentrations. Clearly such a concept would provide a simple explanation of how the hormonal integration, coordination, and maintenance of mammary function is achieved. It has already been noted (see page 607) that a connection between milk ejection and the onset of copious lactation has been suggested. There is considerable evidence that oxytocin is liberated during parturition in sufficient quantities to cause contraction of the alveoli and milk ejection (see Harris, 1955; Cross, 1958; Cross, Goodwin and Silver, 1958); if, therefore, oxytocin can release the lactogenic and galactopoietic complexes from the anterior pituitary, a simple explanation of the mechanism triggering off the onset of copious milk secretion, before the application of the milking stimulus, is available.

We must now consider what experimental evidence there is to support this rather attractive theory. First, Benson and Folley (1956, 1957a, b) demonstrated that regular injections of oxytocin can retard mammary regression after weaning in a similar fashion to injections of prolactin (see page 610), and they have shown that the presence of the pituitary is essential for oxytocin to elicit this effect. Synthetic oxytocin proved equally effective, thus discounting the possibility of a contaminant in natural oxytocin being concerned (Fig. 10.20). These experiments have so far only been carried out in rats, but they strongly suggest that oxytocin can elicit the secretion of prolactin. In agreement with this concept are several observations that regular injections of oxytocin have galactopoietic effects in lactating cows and that oxytocin has luteotropic effects in rats (see review by Benson, Cowie and Tindal, 1958). There is, moreover, some evidence that the suckling stimulus may cause the release of vasopressin or the anti-diuretic hormone (ADH) from the neurohypophysis (see page 621), and it has been shown that ADH or some material closely associated with it may cause the secretion of ACTH from the anterior lobe (see review by Benson, Cowie and Tindal, 1958); so there are some grounds for supposing that the hormones of the posterior lobe evoke the secretion of several components of the



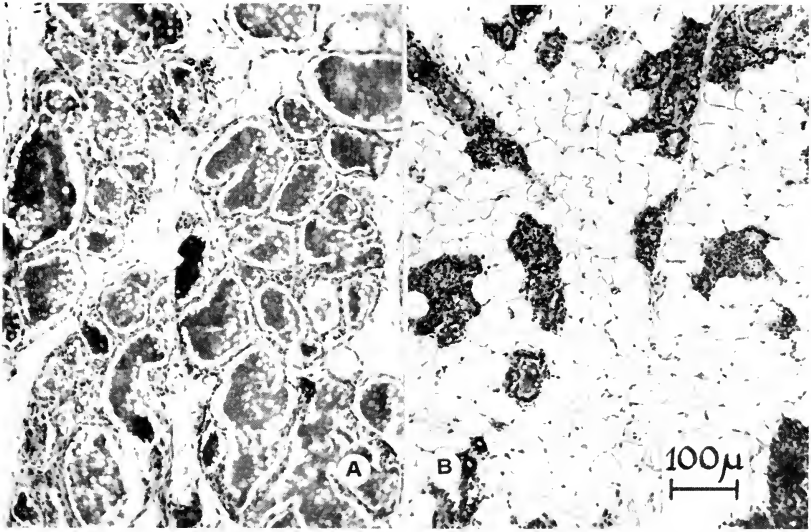

FIG. 10.20. Sections from abdominal mammary gland of rats from which the pups were removed on the fourth day of lactation and which received thereafter for 9 days: A. 1.0 I.U. synthetic oxytocin three times daily. B. Saline daily. Note the maintenance of gland structure in A. (Courtesy of Dr. G. K. Benson.)

galactopoietic complex from the anterior lobe. It was hoped to gain further evidence on this point by studies on hypophysectomized rats bearing pituitary homografts under the kidney capsule (see Benson, Cowie, Folley and Tindal, 1959). As already noted, such grafts secrete prolactin and will give a slight maintenance of milk secretion, but these grafts will not maintain normal milk secretion even when such animals are injected with oxytocin and ADH (Cowie, Tindal and Benson, 1960). It must, therefore, be assumed that if these posterior pituitary hormones are responsible for the release of the galactopoietic complex, some other hypothalamic factor is also necessary to maintain the anterior lobe in a responsive condition. Everett (1956) suggested that the hypothalamus by way of its neurovascular connections with the anterior lobe, normally exerts a partial inhibitory effect on prolactin secretion. It may thus be that when the anterior lobe is removed from hypothalamic influence, the synthetic activities of its cells are centered on prolactin

production to the detriment of the other components of the galactopoietic complex, so that these are no longer available for release in response to neurohypophysial hormones. There is need, however, for experimentation in other species.

The theory that the release of the galactopoietic complex is effected by the hormones of the posterior lobe secreted in response to the suckling stimulus is attractive in that it appears to afford a simple explanation of the hormonal integration of mammary function, but it must be pointed out that the observations on the maintenance of mammary structure after weaning by injections of oxytocin do not prove that prolactin or the galactopoietic complex is released in response to oxytocin under normal conditions of milking or suckling, and more research, particularly in species other than the rat, is necessary. Grosvenor and Turner (1958a) injected oxytocin into anesthetized lactating rats and, on the basis of assays of the pituitary content of prolactin, considered that oxytocin caused no significant release of

prolactin. They had previously shown that there was an immediate fall in the pituitary content of prolactin after nursing (Grosvenor and Turner, 1957b) and therefore concluded that their findings were contrary to the hypothesis that oxytocin is a hormonal link in the discharge of prolactin. This, however, cannot be regarded as conclusive because of the difficulties of relating pituitary content of a hormone to blood levels of the hormone and also the difficulty of determining the physiologic dose of oxytocin, for if the oxytocin is carried directly from the neurohypophysis into the anterior lobe, then the concentration in the blood reaching the anterior lobe may be relatively great (see also Cowie and Folley, 1957).

Other theories of the reflex maintenance of milk secretion have been put forward. In 1953 Tverskoï, observing that repeated injections of oxytocin were galactopoietic in the goat, suggested that alveolar contraction stimulated sensory nerve endings in the alveolar walls which reflexly caused the release of prolactin. It is obvious that his observations could be explained on the basis of the Benson-Folley theory of direct pituitary stimulation by oxytocin. This possibility was indeed considered by Tverskoï, but rejected on the grounds that oxytocin did not affect the prolactin content of the pituitary (Meites and Turner, 1948). In 1957 Tverskoï found it necessary to revise his theory, having found that full lactation could be maintained in the goat after complete and repeated denervation of the udder provided oxytocin was regularly given to evoke milk ejection. He then suggested that alveolar contraction stimulates the synthetic activities of the mammary epithelium causing an uptake of prolactin from the blood, the fall in the blood prolactin level then stimulating the further production of prolactin by the anterior lobe. Although these latter observations of Tverskoï might again be explained on the basis of direct pituitary stimulation by exogenous oxytocin, more recent studies on goats have cast doubts on the validity of such an explanation. Tverskoï (1958) and Denamur and Martinet (1959a, b, 1960) have shown that lactating goats will continue to lactate, giving normal or only moderately reduced

milk yields after section of all nervous connections between the udder and brain (cord section, radicotomy, bilateral sympathetomy) and without their receiving oxytocin and in the absence of conditioned milk-ejection reflexes. It has already been noted that milk ejection in such animals may result from mechanical stimulation of the myoepithelial cells by udder massage (see page 624), but the release of the galactopoietic complex from the anterior pituitary would seem in these goats to have been independent of neurohormonal reflex activities. Whether in such animals the release is spontaneous or dependent on the level of hormones in the blood as suggested by Tverskoï (1957) is a matter for further research.

#### **VI. Pharmacologic Blockade of the Reflexes Concerned in the Maintenance of Milk Secretion and Milk Ejection**

Various attempts have been made to investigate the mechanism controlling release of anterior pituitary hormones by the use of dibenamine, atropine, and other drugs. In reviewing such experiments, Harris (1955) concluded that there was no convincing evidence of the participation of adrenergic, cholinergic, or histaminergic agents in the control of gonadotrophic and adrenocorticotrophic hormone release. Recently Grosvenor and Turner (1957a) reported that various ergot alkaloids, dibenamine, and atropine blocked milk ejection in the rat; the ergot alkaloids doing so within 10 minutes of administration, the atropine and dibenamine within 2 to 4 hours. Inasmuch as milk ejection occurred in response to exogenous oxytocin, it was concluded that these drugs acted centrally, and the presence of adrenergic and cholinergic links in the neurohormone are was postulated to be responsible for the discharge of oxytocin. Later, on the basis of assays of pituitary prolactin after nursing in drug-injected lactating rats, it was suggested that cholinergic and adrenergic links are involved in the reflex responsible for prolactin release (Grosvenor and Turner, 1958a). Ergot alkaloids, however, administered in our laboratory to lactating rats had no significant effect on the lactational per-

formance as judged by the growth of the litters in comparison with the growth of litters of pair-fed control rats, showing that apparent inhibitory effects of the alkaloids on lactation were due to depressed food intake of the mothers (Tindal, 1956a). Inasmuch as growth of the litter depends on efficient milk secretion and milk ejection, Tindal's observations seem to throw doubt on the importance of the adrenergic link in these reflexes. On the other hand, Meites (1959) has reported that adrenaline and acetylcholine can induce or maintain mammary development and milk secretion in suitably prepared rats, observations which could be interpreted as supporting the presence of adrenergic and cholinergic links as postulated by Grosvenor and Turner (1958a).

There have been clinical reports of women developing galactorrhea after treatment with tranquilizing drugs (*e.g.*, Sulman and Winnik, 1956; Marshall and Leiberman, 1956; Platt and Sears, 1956) and interesting observations have recently ap-

peared on the lactogenic effects of reserpine in animals. Milk secretion has been initiated both in virgin rabbits after suitable estrogen priming and in the pseudopregnant rabbit by reserpine (Sawyer, 1957; Meites, 1957a). On the other hand, in our laboratory Tindal (1956b, 1958) had been unable to detect any mammogenic or lactogenic effects with chlorpromazine or reserpine in rabbits (Dutch breed), rats, or goats, nor did reserpine stimulate the crop-sac when injected into pigeons. Recently, using New Zealand White rabbits, Tindal (1960) has induced milk secretion with reserpine. The reason for these contradictory results is not entirely clear, although breed differences in the response would appear to exist in the rabbit. In our laboratory, Benson (1958) has shown that reserpine is strikingly active in retarding mammary involution in the lactating rat after weaning, the effect being of such a magnitude as has so far only been equalled by a combination of prolactin and STH (Fig. 10.21). It has been tentatively suggested that the tranquilizing drugs may

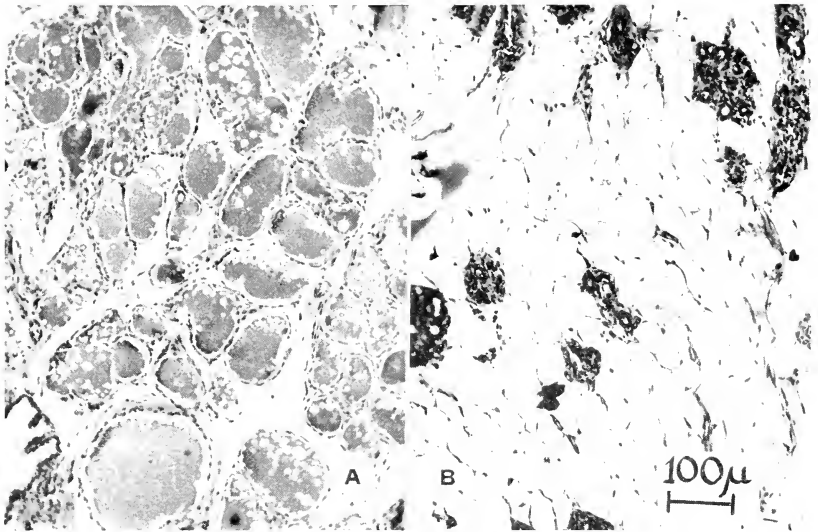

FIG. 10.21. Sections from the abdominal mammary gland of rats from which the pups were removed on the fourth day of lactation and which received thereafter for 9 days: A 100  $\mu$ , reserpine daily. B, Saline daily. Note the retardation of involution effected by reserpine. (Courtesy of Dr. G. K. Benson.)

remove some hypothalamic restraining mechanism on the release of prolactin and probably of other anterior-pituitary hormones (Suhman and Winnik, 1956; Benson, Cowie and Tindal, 1958), an effect which, if confirmed, may throw light on the behavior of pituitary transplants in sites remote from the median eminence.

### VII. Conclusion

Any reader familiar with the chapter on the mammary gland in the previous edition of this book cannot fail to note the main directions in which the subject has advanced in the intervening two decades. These reflect, as they are bound to do, the road taken by the science of endocrinology itself, a road leading to greater biochemical understanding on the one hand and to ever closer rapprochement with neurophysiology on the other.

The mammary gland offers unique opportunities of studying the biochemical mechanisms of hormone action because it is an organ with quite exceptional synthetic capabilities, an organ which is perhaps the most comprehensive hormone target in the mammalian body. Biochemists are entering this promising field in increasing numbers and we may expect to reap the fruits of their labors in the future.

### VIII. References

- ABRAHAM, S., CAMY, P., AND CHAIKOFF, I. L. 1957. Effect of insulin *in vitro* on pathways of glucose utilization, other than Embden-Meyerhof, in rat mammary gland. *J. Biol. Chem.*, **224**, 955-962.
- AHRÉN, K. 1959. The effect of various doses of estrone and progesterone on the mammary glands of castrated hypophysectomized rats injected with insulin. *Acta endocrinol.*, **30**, 435-458.
- AHRÉN, K., AND ÉTIENNE, M. 1957. The development of the mammary gland in normal and castrated male rats after the age of 21 days. *Acta physiol. scandinav.*, **41**, 283-300.
- AHRÉN, K., AND ÉTIENNE, M. 1958. Stimulation of mammary glands in hypophysectomized male rats treated with ovarian hormones and insulin. *Acta endocrinol.*, **23**, 89-102.
- AHRÉN, K., AND JACOBSSON, D. 1956. Mammary gland growth in hypophysectomized rats injected with ovarian hormones and insulin. *Acta physiol. scandinav.*, **37**, 190-203.
- AHRÉN, K., AND JACOBSSON, D. 1957. The action of cortisone on the mammary glands of rats under various states of hormonal imbalance. *Acta physiol. scandinav.*, **40**, 254-274.
- [AL'TMAN, A. D.] АЛЪТМАН, А. Д. 1945. Изменения в вымени коров в процессе раздоя. *Vestnik Zhivotn.*, **1**, 85-96.
- ANDERSSON, B. 1951a. Some observations on the neurohormonal regulations of milk ejection. *Acta physiol. scandinav.*, **23**, 1-7.
- ANDERSSON, B. 1951b. The effect and localization of electrical stimulation of certain parts of the brain stem in sheep and goats. *Acta physiol. scandinav.*, **23**, 8-23.
- ANDERSSON, B. 1951c. Further studies on the milk ejection mechanism in sheep and goats. *Acta physiol. scandinav.*, **23**, 24-30.
- ARDIAN, G. M., COWIE, A. T., AND KEMP, F. H. 1957. A cine-radiographic study of the teat sinus during suckling in the goat. *Vet. Rec.*, **69**, 1100-1101.
- ARDIAN, G. M., COWIE, A. T., AND KEMP, F. H. 1958. Further observations on the teat sinus of the goat during suckling. *Vet. Rec.*, **70**, 808-809.
- ARDIAN, G. M., KEMP, F. H., AND LIND, J. 1958a. A cine-radiographic study of bottle feeding. *Brit. J. Radiol.*, **31**, 11-22.
- ARDIAN, G. M., KEMP, F. H., AND LIND, J. 1958b. A cine-radiographic study of breast feeding. *Brit. J. Radiol.*, **31**, 156-162.
- ARDIAN, G. M., AND KEMP, F. H. 1959. A correlation between suckling pressures and the movements of the tongue. *Acta paediat.*, **48**, 261-272.
- AVEBILL, S. C., RAY, E. W., AND LYONS, W. R. 1950. Maintenance of pregnancy in hypophysectomized rats with placental implants. *Proc. Soc. Exper. Biol. & Med.*, **75**, 3-6.
- BAILEY, G. L., BARTLETT, S., AND FOLLEY, S. J. 1949. Use of L-thyroxine by mouth for stimulating milk secretion in lactating cows. *Nature, London*, **163**, 800.
- BALINSKY, B. I. 1950a. On the prenatal growth of the mammary gland rudiment in the mouse. *J. Anat.*, **84**, 227-235.
- BALINSKY, B. I. 1950b. On the developmental processes in mammary glands and other epidermal structures. *Tr. Roy. Soc. Edinburgh*, **62**, Part 1, 1-31.
- BALMAIN, J. H., COX, C. P., FOLLEY, S. J., AND McNAUGHT, M. L. 1951. The bioassay of insulin *in vitro* by manometric measurements on slices of mammary glands. *J. Endocrinol.*, **11**, 269-276.
- BALMAIN, J. H., AND FOLLEY, S. J. 1951. Further observations on the *in vitro* stimulation by insulin of fat synthesis by lactating mammary gland slices. *Biochem. J.*, **49**, 663-670.
- BALMAIN, J. H., FOLLEY, S. J., AND GLASCOCK, R. F. 1952. Effects of insulin and of glycerol *in vitro* on the incorporation of (carboxy-<sup>14</sup>C) acetate into the fatty acids of lactating mammary gland slices with special reference to species differences. *Biochem. J.*, **52**, 301-305.
- BERGMANN, W., AND KNOOP, A. 1959. Über die Morphologie der Milchsekretion. Licht- und elektronenmikroskopische Studien an der

- Milchdrüse der Ratte. *Ztschr. Zellforsch.*, **49**, 344-388.
- BARTLETT, S., BURT, A. W. A., FOLLEY, S. J. AND ROWLAND, S. J. 1954. Relative galactopoietic effects of 3:5:3-triiodo-L-thyronine and L-thyronine in lactating cows. *J. Endocrinol.*, **10**, 192-201.
- [BARYSHNIKOV, I. A.] Барышников, И. А. 1957. Рефлекторная регуляция лактации. In *Проблемы Физиологии Центральной Нервной Системы*, pp. 62-72. Moscow, Leningrad: Akademiya Nauk S.S.S.R. [Complete translation by F. Lang in *Dairy Science Abstracts*, **21**, 47-53, 1959.]
- BELLER, F. K., KRUMHOLZ, K. H., AND ZEININGER, K. 1958. Vergleichende Oxytocin-Bestimmungen gemessen durch den lactagogen Effect der Milchdrüse. *Acta endocrinol.*, **29**, 1-8.
- BENSON, G. K. 1958. Effect of reserpine on mammary gland involution, and on other organs in the rat. *Proc. Soc. Exper. Biol. & Med.*, **99**, 550-553.
- BENSON, G. K., COWIE, A. T., COX, C. P., FLUX, D. S., AND FOLLEY, S. J. 1955. Studies on the hormonal induction of mammary growth and lactation in the goat. II. Functional and morphological studies of hormonally developed udders with special reference to the effect of "triggering" doses of oestrogen. *J. Endocrinol.*, **13**, 46-58.
- BENSON, G. K., AND COWIE, A. T. 1956. Lactation in the rat after hypophysial posterior lobectomy. *J. Endocrinol.*, **14**, 54-65.
- BENSON, G. K., COWIE, A. T., COX, C. P., AND GOLDZVEIG, S. A. 1957. Effects of oestrone and progesterone on the mammary development in the guinea-pig. *J. Endocrinol.*, **15**, 126-144.
- BENSON, G. K., COWIE, A. T., FOLLEY, S. J., AND TINDAL, J. S. 1959. Recent developments in endocrine studies on mammary growth and lactation. In *Recent Progress in the Endocrinology of Reproduction*, C. W. Lloyd, Ed., pp. 457-490. New York: Academic Press, Inc.
- BENSON, G. K., COWIE, A. T., AND TINDAL, J. S. 1958. The pituitary and the maintenance of milk secretion. *Proc. Roy. Soc., London, ser. B*, **149**, 330-336.
- BENSON, G. K., AND FOLLEY, S. J. 1956. Oxytocin as stimulator for the release of prolactin from the anterior pituitary. *Nature, London*, **177**, 700.
- BENSON, G. K., AND FOLLEY, S. J. 1957a. Retardation of mammary involution in the rat by oxytocin. *J. Endocrinol.*, **14**, xl.
- BENSON, G. K., AND FOLLEY, S. J. 1957b. The effect of oxytocin on mammary gland involution in the rat. *J. Endocrinol.*, **16**, 189-201.
- BÍLEK, J., AND JANOVSKÝ, M. 1956. Studium vlivu oxytocinu na reflex vylučování mléka. *Sborník Českoslov. akad. zemědělských, věd* **29**, 773-780.
- BINTARNINGSIH, LYONS, W. R., JOHNSON, R. E., AND LI, C. H. 1957. Hormonal requirement for lactation in the hypophysectomized rat. *Anat. Rec.*, **127**, 266-267.
- BINTARNINGSIH, LYONS, W. R., JOHNSON, R. E., AND LI, C. H. 1958. Hormonally induced lactation in hypophysectomized rats. *Endocrinology*, **63**, 540-548.
- BLAXTER, K. L. 1952. Some effects of thyroxine and iodinated casein in dairy cows and their practical significance. *Vitamins & Hormones*, **10**, 217-250.
- BRACHET, J. 1957. *Biochemical Cytology*. New York: Academic Press, Inc.
- BRADLEY, T. R., AND CLARKE, P. M. 1956. The response of rabbit mammary glands to locally administered prolactin. *J. Endocrinol.*, **14**, 28-36.
- BRADLEY, T. R., AND COWIE, A. T. 1956. The effects of hypophysectomy on the *in vitro* metabolism of mammary gland slices from lactating rats. *J. Endocrinol.*, **14**, 8-15.
- BRADLEY, T. R., AND MITCHELL, G. M. 1957. The *in vitro* metabolism of mammary gland slices in the presence of posterior pituitary lobe extracts rich in melanophore-dispersing activity. *J. Endocrinol.*, **15**, 366-373.
- BRAUDE, R. 1951. Pig nutrition. In *Progress in the Physiology of Farm Animals*, J. Hammond, Ed., Vol. 1, Ch. 2, pp. 40-105. London: Butterworth & Company, Ltd.
- BRAUDE, R., AND MITCHELL, K. G. 1952. Observations on the relationship between oxytocin and adrenaline in milk ejection in the sow. *J. Endocrinol.*, **8**, 238-241.
- BUSCH, D. W. H. 1839. Das Geschlechtsleben des Weibes in physiologischer, pathologischer und therapeutischer Hinsicht. In *Physiologie und allgemeine Pathologie des weiblichen Geschlechtslebens*, Vol. I. Leipzig, F. A. Brockhaus.
- CAMPBELL, B., AND PETERSEN, W. E. 1953. Milk "let-down" and the orgasm in the human female. *Human Biol.*, **25**, 165-168.
- CANTVENC, R. 1952. L'activité endocrine du placenta de la ratte. *Arch. anat.*, **34**, 105-118.
- CANTVENC, R., AND MAYER, G. 1953. Nature du facteur lutéotrophique de placenta de rat. *Compt. rend. Soc. biol.*, **147**, 1067-1070.
- CHALMERS, J. R., DICKSON, G. T., ELKS, J., AND HEMS, B. A. 1949. The synthesis of thyroxine and related substances. V. A synthesis of L-thyroxine from L-tyrosine. *J. Chem. Soc.*, 3424-3433.
- CHEN, L. T., JOHNSON, R. E., LYONS, W. R., LI, C. H., AND COLE, R. D. 1955. Hormonally induced mammary growth and lactation in the absence of the thyroid. *Endocrinology*, **57**, 153-157.
- COLE, H. A. 1933. The mammary gland of the mouse, during the estrous cycle, pregnancy and lactation. *Proc. Roy. Soc., London, ser. B*, **114**, 136-160.
- COOPER, SIR JASTLEY P. 1840. *On the Anatomy of the Breast*. London: Longmans, Orme, Green, Brown & Longmans.
- COTES, P. M., CRICHTON, J. A., FOLLEY, S. J., AND YOUNG, F. G. 1949. Galactopoietic activity

- of isolated anterior pituitary growth hormone. *Nature, London*, **164**, 992-993.
- COWIE, A. T. 1949. The relative growth of the mammary gland in normal, gonadectomized and adrenalectomized rats. *J. Endocrinol.*, **6**, 145-157.
- COWIE, A. T. 1952. Influence on the replacement value of some adrenal cortex steroids of dietary sodium and synergism of steroids in lactating and adrenalectomized rats. *Endocrinology*, **51**, 217-225.
- COWIE, A. T. 1957. The maintenance of lactation in the rat after hypophysectomy. *J. Endocrinol.*, **16**, 135-147.
- COWIE, A. T. 1960. The hormonal control of milk secretion. In *Milk: The Mammary Gland and its Secretion*, S. K. Kon and A. T. Cowie, Eds., Ch. 4. New York: Academic Press, Inc.
- COWIE, A. T., COX, C. P., AND NAITO, M. 1957. National Institute for Research in Dairying, Report 1957, p. 55.
- COWIE, A. T., AND FOLLEY, S. J. 1945. Parathyroidectomy and lactation in the rat. *Nature, London*, **156**, 719.
- COWIE, A. T., AND FOLLEY, S. J. 1947a. The measurement of lactational performance in the rat in studies of the endocrine control of lactation. *J. Endocrinol.*, **5**, 9-13.
- COWIE, A. T., AND FOLLEY, S. J. 1947b. Adrenalectomy and replacement therapy in lactating rats. II. Effects of deoxycorticosterone acetate on lactation in adrenalectomized rats. *J. Endocrinol.*, **5**, 14-23.
- COWIE, A. T., AND FOLLEY, S. J. 1947c. Adrenalectomy and replacement therapy in lactating rats. III. Effects of deoxycorticosterone acetate and 11-oxygenated cortical steroids on lactation in adrenalectomized rats maintained on stock or high-protein diets. *J. Endocrinol.*, **5**, 24-31.
- COWIE, A. T., AND FOLLEY, S. J. 1947d. The role of the adrenal cortex in mammary development and its relation to the mammogenic action of the anterior pituitary. *Endocrinology*, **40**, 274-285.
- COWIE, A. T., AND FOLLEY, S. J. 1957. Neurohypophysial hormones and the mammary gland. In *The Neurohypophysis*, H. Heller, Ed., pp. 183-197. London: Butterworth & Company, Ltd.
- COWIE, A. T., FOLLEY, S. J., CROSS, B. A., HARRIS, G. W., JACOBSON, D., AND RICHARDSON, K. C. 1951. Terminology for use in lactational physiology. *Nature, London*, **168**, 121.
- COWIE, A. T., FOLLEY, S. J., MALPRESS, F. H., AND RICHARDSON, K. C. 1952. Studies on the hormonal induction of mammary growth and lactation in the goat. *J. Endocrinol.*, **8**, 64-88.
- COWIE, A. T., AND LYONS, W. R. 1959. Mammogenesis and lactogenesis in hypophysectomized, ovariectomized, adrenalectomized rats. *J. Endocrinol.*, **19**, 29-32.
- COWIE, A. T., AND TINDAL, J. S. 1955. Maintenance of lactation in adrenalectomized rats with aldosterone and 9 $\alpha$ -halo derivatives of hydrocortisone. *Endocrinology*, **56**, 612-614.
- COWIE, A. T., AND TINDAL, J. S. 1958. Adrenalectomy in the goat: replacement therapy and the maintenance of lactation. *J. Endocrinol.*, **16**, 403-414.
- COWIE, A. T., AND TINDAL, J. S. 1960. Effects of hypophysectomy of the pregnant and lactating goat. *Acta endocrinol., Suppl.* 51, **35**, pp. 679-680.
- COWIE, A. T., TINDAL, J. S., AND BENSON, G. K. 1960. Pituitary grafts and milk secretion in hypophysectomized rats. *J. Endocrinol.*, **21**, 115-123.
- CROSS, B. A. 1950. Suckling antidiuresis in rabbits. *Nature, London*, **166**, 612-613.
- CROSS, B. A. 1953. Sympathetic-adrenal inhibition of the neurohypophysial milk-ejection mechanism. *J. Endocrinol.*, **9**, 7-18.
- CROSS, B. A. 1954. Milk ejection resulting from mechanical stimulation of mammary myoepithelium in the rabbit. *Nature, London*, **173**, 450-451.
- CROSS, B. A. 1955a. The hypothalamus and the mechanism of sympathetic-adrenal inhibition of milk ejection. *J. Endocrinol.*, **12**, 15-28.
- CROSS, B. A. 1955b. Neurohormonal mechanisms in emotional inhibition of milk ejection. *J. Endocrinol.*, **12**, 29-37.
- CROSS, B. A. 1958. On the mechanism of labour in the rabbit. *J. Endocrinol.*, **16**, 261-276.
- CROSS, B. A. 1960. Neural control of lactation. In *Milk: The Mammary Gland and its Secretion*, S. K. Kon and A. T. Cowie, Eds., Ch. 6. New York: Academic Press, Inc.
- CROSS, B. A., GOODWIN, R. F. W., AND SHAYER, I. A. 1958. A histological and functional study of the mammary gland in normal and agalactic sows. *J. Endocrinol.*, **17**, 63-74.
- CROSS, B. A., AND HARRIS, G. W. 1950. Milk ejection following electrical stimulation of the pituitary stalk in rabbits. *Nature, London*, **166**, 994-995.
- CROSS, B. A., AND HARRIS, G. W. 1952. The role of the neurohypophysis in the milk-ejection reflex. *J. Endocrinol.*, **8**, 148-161.
- CROSS, B. A., AND SILVER, I. A. 1956. Milk ejection and mammary engorgement. *Proc. Roy. Soc. Med.*, **49**, 978-979.
- DABELOW, A. 1957. Die Milchdrüse. In *Handbuch der mikroskopischen Anatomie des Menschen*, W. von Möllendorf and W. Bargmann, Eds., Vol. 3, Part 3, pp. 277-485. Berlin, Göttingen, Heidelberg: Julius Springer.
- DAMM, H. C., AND TURNER, C. W. 1958. Evidence for existence of mammogenic hormone. *Proc. Soc. Exper. Biol. & Med.*, **99**, 471-473.
- DANIEL, P. M., AND PRICHARD, M. M. L. 1956. Anterior pituitary necrosis: infarction of the pars distalis produced experimentally in the rat. *Quart. J. Exper. Physiol.*, **41**, 215-219.
- DANIEL, P. M., AND PRICHARD, M. M. L. 1957. The vascular arrangements of the pituitary gland of the sheep. *Quart. J. Exper. Physiol.*, **42**, 237-248.
- DANIEL, P. M., AND PRICHARD, M. M. L. 1958. The effects of pituitary stalk section in the goat. *Am. J. Path.*, **34**, 433-469.

- DE JONGH, S. E. 1932. Corpus Luteum und Laktation. *Acta brev. neerl. Physiol.*, **2**, 199-121.
- DENAMUR, R., AND MARTINET, J. 1953. Sensibilité de la glande mammaire de la chèvre aux hormones posthypophysaires. *Compt. rend. Soc. biol.*, **147**, 1217-1220.
- DENAMUR, R., AND MARTINET, J. 1959a. Les stimulus nerveux mammaires sont-ils nécessaires à l'entretien de la lactation chez la chèvre? *Compt. rend. Acad. Sc.*, **248**, 743-746.
- DENAMUR, R., AND MARTINET, J. 1959b. Entretien de la lactation chez la chèvre après section de la moelle-épinrière et sympathectomie lombaire. *Compt. rend. Acad. Sc.*, **248**, 860-862.
- DENAMUR, R., AND MARTINET, J. 1960. Physiological mechanisms concerned in the maintenance of lactation in the goat and sheep. *Nature, London*, **185**, 252-253.
- DESCLIN, L. 1950. À propos du mécanisme d'action des oestrogènes sur le lobe antérieur de l'hypophyse chez le rat. *Ann. endocrinol.*, **11**, 656-659.
- DESCLIN, L. 1952. Recherches sur le déterminisme des phénomènes de sécrétion dans la glande mammaire du rat. *Ann. endocrinol.*, **13**, 120-136.
- DESCLIN, L. 1956. Hypothalamus et libération d'hormone lutéotrophique. Expériences de greffe hypophysaire chez le rat hypophysectomisé: action lutéotrophique de l'oxytocine. *Ann. endocrinol.*, **17**, 586-595.
- DONKER, J. D. 1958. Lactation studies. I. Effects upon milk ejection in the bovine of various injection treatments using oxytocin and relaxin. *J. Dairy Sci.*, **41**, 537-544.
- DONOVAN, B. T., AND VAN DER WERFF TEN BOSCH, J. J. 1957. The hypothalamus and lactation in the rabbit. *J. Physiol.*, **137**, 410-420.
- EAYRS, J. T., AND BADDELEY, R. M. 1956. Neural pathways in lactation. *J. Anat.*, **90**, 161-171.
- ELIAS, J. J. 1957. Cultivation of adult mouse mammary gland in hormone-enriched synthetic medium. *Science*, **126**, 842-844.
- ELY, F., AND PETERSEN, W. E. 1941. Factors involved in the ejection of milk. *J. Dairy Sci.*, **24**, 211-223.
- EVERETT, J. W. 1954. Lutotrophic function of autografts of the rat hypophysis. *Endocrinology*, **54**, 685-690.
- EVERETT, J. W. 1956. Functional corpora lutea maintained for months by autografts of rat hypophyses. *Endocrinology*, **58**, 786-796.
- FAUVET, E. 1941a. Experimentelle Untersuchungen über den Laktationsvorgang. *Zentralbl. Gynäk.*, **65**, 580-584.
- FAUVET, E. 1941b. Vergleichende Untersuchungen über die Entwicklung und Funktion der Milchdrüsen. VIII. Experimentelle Untersuchungen über die Wirkung von Follikelhormonzufuhr auf die Milchdrüsen säugender Ratten. *Arch. Gynäk.*, **171**, 342-366.
- FLUX, D. S. 1954a. Growth of the mammary duct system in intact and ovariectomized mice of the CHI strain. *J. Endocrinol.*, **11**, 223-237.
- FLUX, D. S. 1954b. The effect of adrenal steroids on the growth of the mammary glands, uteri, thymus and adrenal glands of intact, ovariectomized and adrenalectomized mice. *J. Endocrinol.*, **11**, 238-254.
- FLUX, D. S. 1955. The value of some steroids in replacement therapy in adrenalectomized and adrenalectomized - ovariectomized lactating rats. *J. Endocrinol.*, **12**, 57-68.
- FLUX, D. S. 1958. Mammary gland growth in male mice of the CHI strain after hypophysectomy and castration. *J. Endocrinol.*, **17**, 300-306.
- FLUX, D. S., FOLLEY, S. J., AND ROWLAND, S. J. 1954. The effect of adrenocorticotrophic hormone on the yield and composition of the milk of the cow. *J. Endocrinol.*, **10**, 333-339.
- FLUX, D. S., AND MCNFORD, R. E. 1957. The effects of adrenocorticotrophin on the mammary glands of intact mature female mice of the CHI strain. *J. Endocrinol.*, **14**, 343-347.
- FOLLEY, S. J. 1936. The effect of oestrogenic hormones on lactation and on the phosphatase of the blood and milk of the lactating cow. *Biochem. J.*, **30**, 2262-2272.
- FOLLEY, S. J. 1940. Lactation. *Biol. Rev.*, **15**, 421-458.
- FOLLEY, S. J. 1947. The nervous system and lactation. *Brit. M. Bull.*, **5**, 142-148.
- FOLLEY, S. J. 1952a. Lactation. In *Marshall's Physiology of Reproduction*, 3rd ed., A. S. Parkes, Ed., Vol. II, Ch. 20. London: Longmans, Green & Company.
- FOLLEY, S. J. 1952b. Aspects of pituitary-mammary gland relationships. *Recent Progr. Hormone Res.*, **7**, 107-137.
- FOLLEY, S. J. 1954. *Recherches Récentes sur la Physiologie et la Biochimie de la Sécrétion Lactée*. Liège: Desoer; Paris: Masson et Cie.
- FOLLEY, S. J. 1955. Effects of somatotrophin and other pituitary hormones on the lactating mammary gland. In *The Hypophysal Growth Hormone, Nature and Actions*, R. W. Smith, O. H. Gaebler and C. N. H. Long, Eds., pp. 473-486. New York: Blakiston Company.
- FOLLEY, S. J. 1956. *The Physiology and Biochemistry of Lactation*. Edinburgh and London: Oliver & Boyd, Ltd.
- FOLLEY, S. J., AND COWIE, A. T. 1944. Adrenalectomy and replacement therapy in lactating rats. *Yale J. Biol. & Med.*, **17**, 67-74.
- FOLLEY, S. J., AND FRENCH, T. H. 1949. The intermediary metabolism of the mammary gland. II. Respiration and acid production of mammary tissue during pregnancy, lactation and involution in the rat. *Biochem. J.*, **45**, 270-275.
- FOLLEY, S. J., AND FRENCH, T. H. 1950. Intermediary metabolism of the mammary gland. III. Acetate metabolism of lactating mammary gland slices with special reference to milk fat synthesis. *Biochem. J.*, **46**, 465-473.
- FOLLEY, S. J., AND GREENBAUM, A. L. 1947. Changes in the arginase and alkaline phosphatase contents of the mammary glands and liver of the rat during pregnancy, lactation and mammary involution. *Biochem. J.*, **41**, 261-269.
- FOLLEY, S. J., AND GREENBAUM, A. L. 1948. Effect

- of adrenalectomy on the arginase levels of the liver, mammary gland and kidney in lactating rats studied by the paired-feeding technique. *Biochem. J.*, **43**, 581-584.
- FOLLEY, S. J., GÜTHKELCH, A. N., AND ZUCKERMAN, S. 1939. The mammary gland of the rhesus monkey under normal and experimental conditions. *Proc. Roy. Soc., London, ser. B*, **126**, 469-491.
- FOLLEY, S. J., AND KON, S. K. 1938. The effect of sex hormones on lactation in the rat. *Proc. Roy. Soc., London, ser. B*, **124**, 476-492.
- FOLLEY, S. J., AND McNAUGHT, M. L. 1958. Hormonal effects *in vitro* on lipogenesis in mammary tissue. *Brit. Med. Bull.*, **14**, 207-211.
- FOLLEY, S. J., AND McNAUGHT, M. L. 1960. Biosynthesis of milk fat. In *Milk: The Mammary Gland and its Secretion*, S. K. Kon and A. T. Cowie, Eds., Ch. 12. New York: Academic Press, Inc.
- FOLLEY, S. J., AND MALPRESS, F. H. 1948a. Hormonal control of mammary growth. In *The Hormones*, G. Pincus and K. V. Thimann, Eds., Ch. XV. New York: Academic Press, Inc.
- FOLLEY, S. J., AND MALPRESS, F. H. 1948b. Hormonal control of lactation. In *The Hormones*, G. Pincus and K. V. Thimann, Eds., Ch. XVI. New York: Academic Press, Inc.
- FOLLEY, S. J., AND YOUNG, F. G. 1941. Prolactin as a specific lactogenic hormone. *Lancet*, **240**, 380-381.
- GAINES, W. L. 1915. A contribution to the physiology of lactation. *Am. J. Physiol.*, **38**, 285-312.
- GAUNT, R., EVERSOLE, W. J., AND KENDALL, E. C. 1942. Influence of some steroid hormones on lactation in adrenalectomized rats. *Endocrinology*, **31**, 84-88.
- GLOCK, G. E., AND McLEAN, P. 1954. Levels of enzymes of the direct oxidative pathways of carbohydrate metabolism in mammalian tissues and tumours. *Biochem. J.*, **56**, 171-175.
- GLOCK, G. E., AND McLEAN, P. 1958. Pathways of glucose utilization in mammary tissue. *Proc. Roy. Soc., London, ser. B*, **149**, 354-362.
- GLOCK, G. E., McLEAN, P., AND WHITEHEAD, J. K. 1956. Pathways of glucose utilization in the mammary gland of the rat. *Biochim. et biophys. acta*, **19**, 546-547.
- GOMEZ, E. T. 1939. The relation of the posterior hypophysis in the maintenance of lactation in hypophysectomized rats. *J. Dairy Sci.*, **22**, 488.
- GOMEZ, E. T. 1940. Effect of posthypophysial extract on lactation in hypophysectomized post-gravid rats. *J. Dairy Sci.*, **23**, 537-538.
- [GRACHEV, I. I.] ГРАЧЕВ, И. И. 1953. Условный рефлектор с молочной железой. *Vestnik Leningrad. Universitet*, No. 4, 87-99.
- [GRACHEV, I. I.] ГРАЧЕВ, И. И. 1958. Высшая нервная деятельность и секреция молока. *Vestnik Leningrad. Universitet*, No. 21, 110-121.
- GRACMANN, W. 1952. Mikroskopische Anatomie der männlichen Brustdrüse. I. Kindheit und Pubertät. *Ztschr. mikro-anat. Forsch.*, **58**, 358-379.
- GRACMANN, W. 1953. Mikroskopische Anatomie der männlichen Brustdrüse. II. Mannesalter und Senium. *Ztschr. mikro-anat. Forsch.*, **59**, 523-557.
- GREENBAUM, A. L., AND GREENWOOD, F. C. 1954. Some enzymic changes in the mammary gland of rats during pregnancy, lactation and mammary involution. *Biochem. J.*, **56**, 625-631.
- GREENBAUM, A. L., AND SLATER, T. F. 1957a. Studies on the particulate components of rat mammary gland. II. Changes in the levels of the nucleic acids of the mammary glands of rats during pregnancy, lactation and mammary involution. *Biochem. J.*, **66**, 155-161.
- GREENBAUM, A. L., AND SLATER, T. F. 1957b. Studies on the particulate components of rat mammary gland. III. The relationship between enzyme activity and particle counts in mammary gland suspensions. *Biochem. J.*, **66**, 161-166.
- GRÉGOIRE, C. 1947. Factors involved in maintaining involution of the thymus during suckling. *J. Endocrinol.*, **5**, 68-87.
- GRIFFITH, D. R., AND TURNER, C. W. 1957. Desoxyribonucleic acid (DNA) content of mammary gland during pregnancy and lactation. *Proc. Soc. Exper. Biol. & Med.*, **95**, 347-348.
- GROSVENOR, C. E., AND TURNER, C. W. 1957a. Evidence for adrenergic and cholinergic components in milk let-down reflex in lactating rats. *Proc. Soc. Exper. Biol. & Med.*, **95**, 719-722.
- GROSVENOR, C. E., AND TURNER, C. W. 1957b. Release and restoration of pituitary lactogen in response to nursing stimuli in lactating rats. *Proc. Soc. Exper. Biol. & Med.*, **96**, 723-725.
- GROSVENOR, C. E., AND TURNER, C. W. 1958a. Effects of oxytocin and blocking agents upon pituitary lactogen discharge in lactating rats. *Proc. Soc. Exper. Biol. & Med.*, **97**, 463-465.
- GROSVENOR, C. E., AND TURNER, C. W. 1958b. Effect of lactation upon thyroid secretion rate in the rat. *Proc. Soc. Exper. Biol. & Med.*, **99**, 517-519.
- GROSVENOR, C. E., AND TURNER, C. W. 1958c. Pituitary lactogenic hormone concentration and milk secretion in lactating rats. *Endocrinology*, **63**, 535-539.
- HADFIELD, G. 1957. The nature and origin of the mammothropic agent present in human female urine. *Lancet*, **i**, 1058-1061.
- HADFIELD, G., AND YOUNG, S. 1958. The controlling influence of the pituitary on the growth of the normal breast. *Brit. J. Surg.*, **46**, 265-273.
- HAMMOND, J., AND MARSHALL, F. H. A. 1925. *Reproduction in the Rabbit*. Edinburgh, London: Oliver & Boyd, Ltd.
- HARDY, M. H. 1950. The development *in vitro* of the mammary glands of the mouse. *J. Anat.*, **84**, 388-393.
- HARRIS, G. W. 1947. The innervation and actions of the neurohypophysis, an investigation using the method of remote-control stimulation. *Phil. Tr. Roy. Soc., London, ser. B*, **232**, 385-441.
- HARRIS, G. W. 1955. *Neural Control of the Pituitary Gland*. London: Edward Arnold & Company.



- HARRIS, G. W. 1958. The central nervous system, neurohypophysis and milk ejection. *Proc. Roy. Soc., London, ser. B*, **149**, 336-353.
- HARRIS, G. W., AND JACOBSON, D. 1952. Functional grafts of the anterior pituitary gland. *Proc. Roy. Soc., London, ser. B*, **139**, 263-276.
- HARRIS, G. W., AND PICKLES, V. R. 1953. Reflex stimulation of the neurohypophysis (posterior pituitary gland) and the nature of the posterior pituitary hormones. *Nature, London*, **172**, 1049.
- HAWKER, R. W. 1958. Oxytocin in lactating and nonlactating women. *J. Clin. Endocrinol.*, **18**, 54-70.
- HAWKER, R. W., AND ROBERTS, V. S. 1957. Oxytocin in lactating cows and goats. *Brit. Vet. J.*, **113**, 459-464.
- HAWKER, R. W., AND ROBERTSON, P. A. 1957. Oxytocin in human female blood. *Endocrinology*, **60**, 652-657.
- HAYS, R. L., AND VANDEMARK, N. L. 1953. Effect of stimulation of the reproductive organs of the cow on the release of an oxytocin-like substance. *Endocrinology*, **52**, 634-637.
- HEINEMAN, P. G. 1919. *Milk*. Philadelphia: W. B. Saunders Company.
- HÖHN, E. O. 1957. The effect of oestrone on the mammary gland of adrenalectomized guinea-pigs. *J. Endocrinol.*, **16**, 227-230.
- HOLLMANS, K. H. 1959. L'ultrastructure de la glande mammaire normale de la souris en lactation. Étude au microscope électronique. *J. Ultrastructure Res.*, **2**, 423-433.
- HOCSSAY, B. A. 1935. Action de l'hypophysectomie sur la grossesse et la sécrétion lactée, chez la chienne. *Compt. rend. Soc. biol.*, **120**, 496-497.
- HOVE, A., RICHARDSON, K. C., AND BRIBBECK, M. S. C. 1956. Quantitative observations on mitochondria from sections of guinea-pig mammary gland. *Exper. Cell Res.*, **10**, 194-213.
- HUGGINS, C., AND MAINZER, K. 1957. Hormonal influences on mammary tumors of the rat. II. Retardation of growth of a transplanted fibroadenoma in intact female rats by steroids in the androstane series. *J. Exper. Med.*, **105**, 485-500.
- HUGGINS, C., AND MAINZER, K. 1958. In *Endocrine Aspects of Breast Cancer*, A. R. Currie, Ed., pp. 297-304. Edinburgh, London: E. & S. Livingstone, Ltd.
- HUGHES, E. S. R. 1950. The development of the mammary gland. *Ann. Roy. Coll. Surgeons, England*, **6**, 99-119.
- HUTTON, J. B. 1957. The effect of growth hormone on the yield and composition of cows' milk. *J. Endocrinol.*, **16**, 115-125.
- HUTTON, J. B. 1958. Oestrogen function in established lactation in the cow. *J. Endocrinol.*, **17**, 121-133.
- HUXLEY, J. S., AND TEISSIER, G. 1936. Terminology of relative growth. *Nature, London*, **137**, 780-781.
- INGLE, D. J. 1954. Permissibility of hormone action: a review. *Acta endocrinol.*, **17**, 172-186.
- INGLEBY, H., MOORE, L., AND GERSON-COHEN, J. 1957. Gestational breast changes. *Obst. & Gynecol.*, **10**, 149-157.
- ISBISTER, C. 1954. Clinical study of the draught reflex in human lactation. *Arch. Dis. Childhood*, **29**, 66-72.
- JACOBSON, D. 1958. Mammary gland growth in relation to hormones with metabolic actions. *Proc. Roy. Soc., London, ser. B*, **149**, 325-329.
- JACOBSON, D. 1959. Thyroxine and the reaction of the mammary glands to ovarian steroids in hypophysectomized rats. *J. Physiol.*, **148**, 10P-11P.
- JEFFERS, K. R. 1935. Cytology of the mammary gland of the albino rat. I. Pregnancy, lactation, and involution. *Am. J. Anat.*, **56**, 257-277.
- JEWELL, P. A. 1956. The vascular link between posterior and anterior lobes of the pituitary. *J. Endocrinol.*, **14**, xxiv.
- JOHNSON, R. M., AND MEITES, J. 1955. Effects of cortisone, hydrocortisone, and ACTH on mammary growth and pituitary prolactin content of rats. *Proc. Soc. Exper. Biol. & Med.*, **89**, 455-458.
- JOHNSON, R. M., AND MEITES, J. 1958. Effects of cortisone acetate on milk production and mammary involution in parturient rats. *Endocrinology*, **63**, 290-294.
- KALLIALA, H., AND KARVONEN, M. J. 1951. Antidiuresis during suckling in lactating women. *Ann. med. exper. et biol. Fenniae*, **29**, 234-241.
- KALLIALA, H., KARVONEN, M. J., AND LEPPANEN, V. 1952. Release of antidiuretic hormone during nursing in dog. *Ann. med. exper. et biol. Fenniae*, **30**, 96-107.
- KIRKHAM, W. R., AND TURNER, C. W. 1953. Nucleic acids of the mammary glands of rats. *Proc. Soc. Exper. Biol. & Med.*, **83**, 123-126.
- KOLBE, P. 1727. Naukeurige en uitvoerige beschryving van de Kaap de Goede Hoop. Amsterdam. Quoted by Martiny, 1871.
- KRZYWANEK, F. W., AND BRÜGGEMANN, H. 1930. Modellversuche zur Physiologie des Saugaktes. *Berl. tier. Wehnschr.*, **46**, 710-713.
- KURAMITSU, C., AND LOEB, J. 1921. The effect of suckling and castration on the lactating mammary gland in rat and guinea pig. *Am. J. Physiol.*, **61**, 40-59.
- LANDSMEER, J. M. F. 1951. Vessels of the rat's hypophysis. *Acta anat.*, **12**, 83-109.
- LAURYSSSENS, M., PEETERS, G., AND DONCK, A. 1956. Variations dans la teneur du coenzyme A dans la glande mammaire chez le rat. *Ann. endocrinol.*, **17**, 543-546.
- LEECH, F. B., AND BAILEY, G. L. 1953. The effect on the health of lactating cows of treatment with galactopoietic doses of thyroxine or iodinated casein. *J. Agric. Sci.*, **43**, 236-251.
- LESLIE, I. 1955. The nucleic acid content of tissues and cells. In *The Nucleic Acids: Chemistry and Biology*, E. Chargaff and J. N. Davidson, Eds., Ch. 16, pp. 1-50. New York: Academic Press, Inc.
- LEWIN, I. 1957. Xanthine oxidase activity in

- normal and abnormal growth. Proc. Roy. Soc. Med., **50**, 563-570.
- LINZELL, J. L. 1952. The silver staining of myo-epithelial cells, particularly in the mammary gland, and their relation to the ejection of milk. *J. Anat.*, **86**, 49-57.
- LINZELL, J. L. 1955. Some observations on the contractile tissue of the mammary glands. *J. Physiol.*, **130**, 257-267.
- LUNDAHL, W. S., MEITES, J., AND WOLTERINK, L. F. 1950. A technique for whole mount autoradiographs of rabbit mammary glands. *Science*, **112**, 599-600.
- LYONS, W. R. 1942. The direct mammotrophic action of lactogenic hormone. Proc. Soc. Exper. Biol. & Med., **51**, 308-311.
- LYONS, W. R. 1943. Lobulo-alveolar mammary growth induced in hypophysectomized rats by injections of ovarian and hypophysal hormones. In *Essays in Biology in Honor of Herbert M. Evans*, pp. 315-329. Berkeley: University of California Press.
- LYONS, W. R. 1958. Hormonal synergism in mammary growth. Proc. Roy. Soc., London, ser. B, **149**, 303-325.
- LYONS, W. R., LI, C. H., COLE, R. D., AND JOHNSON, R. E. 1953. Some of the hormones required by the mammary gland in its development and functions. *J. Clin. Endocrinol.*, **13**, 836-837.
- LYONS, W. R., LI, C. H., AND JOHNSON, R. E. 1952. The enhancing effect of somatotropin on the mammary growth induced in rats with estrin, progesterin and mammotropin. *J. Clin. Endocrinol.*, **12**, 937.
- LYONS, W. R., LI, C. H., AND JOHNSON, R. E. 1958. The hormonal control of mammary growth and lactation. Recent Progr. in Hormone Res. **14**, 219-254.
- MARSHALL, W. K., AND LEIBERMAN, D. M. 1956. A rare complication of chlorpromazine treatment. *Lancet*, **270**, 162.
- MARTINY, B. 1871. *Die Milch, ihr Wesen und ihre Verwerthung*, Vol. I. Danzig: Kascmann.
- MARTYUGIN, D. D. [MARTYUKH, D. D. 1944. Чувствительность к ооцария у телят. Труд Тимирязева sel.-khoz. Akad., No. 31, 149-184.]
- MASSON, G. M. 1948. Effects of estradiol and progesterone on lactation. *Anat. Rec.*, **102**, 513-520.
- MAYER, G., AND KLEIN, M. 1948. Physiologie de la lactation. I. Les facteurs du développement morphologique du parenchyme mammaire. *Ann. Nutr. Aliment.*, Paris, **2**, 113-157.
- MAYER, G., AND KLEIN, M. 1949. Physiologie de la lactation. II. Les facteurs de l'activité fonctionnelle du parenchyme mammaire. *Ann. Nutr. Aliment.*, Paris, **3**, 667-748.
- MCLEAN, P. 1958a. Carbohydrate metabolism of mammary tissue. I. Pathways of glucose catabolism in the mammary gland. *Biochim. et biophys. acta*, **30**, 303-315.
- MCLEAN, P. 1958b. Carbohydrate metabolism of mammary tissue. II. Levels of oxidized and reduced diphosphopyridine nucleotide and triphosphopyridine nucleotide in the rat mammary gland. *Biochim. et biophys. acta*, **30**, 316-324.
- MCLEAN, P. 1959. Effect of insulin and phenazine methosulphate on pathways of glucose catabolism in the mammary gland of the rat. *Nature, London*, **183**, 182-183.
- MCNAUGHT, M. L. 1956. National Institute for Research in Dairying, Report 1956, p. 59.
- MCNAUGHT, M. L. 1957. National Institute for Research in Dairying, Report 1957, p. 58.
- MCNAUGHT, M. L. 1958. The use of the mammary-slice bioassay method for the estimation of insulin in glucagon. *J. Endocrinol.*, **17**, xvi-xvii.
- MEITES, J. 1954. Recent studies on the mechanisms controlling the initiation of lactation. *Rev. canad. Biol.*, **13**, 359-370.
- MEITES, J. 1957a. Induction of lactation in rabbits with reserpine. Proc. Soc. Exper. Biol. & Med., **96**, 728-730.
- MEITES, J. 1957b. Effects of growth hormone on lactation and body growth of parturient rats. Proc. Soc. Exper. Biol. & Med., **96**, 730-732.
- MEITES, J. 1959. Induction and maintenance of mammary growth and lactation in rats with acetylcholine or epinephrine. Proc. Soc. Exper. Biol. & Med., **100**, 750-754.
- MEITES, J. 1960. Farm animals: hormonal induction of lactation and galactopoiesis. In *Milk: the Mammary Gland and its Secretion*, S. K. Kon and A. T. Cowie, Eds., Ch. 8. New York: Academic Press, Inc.
- MEITES, J., AND SGOURIS, J. T. 1953. Can the ovarian hormones inhibit the mammary response to prolactin? *Endocrinology*, **53**, 17-23.
- MEITES, J., AND SGOURIS, J. T. 1954. Effects of altering the balance between prolactin and ovarian hormones on initiation of lactation in rabbits. *Endocrinology*, **55**, 530-534.
- MEITES, J., AND TURNER, C. W. 1942a. Studies concerning the mechanism controlling the initiation of lactation at parturition. I. Can estrogen suppress the lactogenic hormone of the pituitary? *Endocrinology*, **30**, 711-718.
- MEITES, J., AND TURNER, C. W. 1942b. Studies concerning the mechanism controlling the initiation of lactation at parturition. III. Can estrogen account for the precipitous increase in the lactogen content of the pituitary following parturition? *Endocrinology*, **30**, 726-733.
- MEITES, J., AND TURNER, C. W. 1947. The induction of lactation during pregnancy in rabbits and the specificity of the lactogenic hormone. *Am. J. Physiol.*, **150**, 394-399.
- MEITES, J., AND TURNER, C. W. 1948. Studies concerning the induction and maintenance of lactation. I. The mechanism controlling the initiation of lactation at parturition. *Res. Bull. Missouri Agric. Exper. Sta.*, No. 415.
- MERCIER-PAROT, L. 1955. Troubles du développement postnatal du rat après administration de cortisone à la mère gestante ou allaitante. *Compt. rend. Acad. Sc.*, **240**, 2259.

- MIXNER, J. P., AND TURNER, C. W. 1943. The mirmogenetic hormones of the anterior pituitary. II. The lobule-alveolar growth factor. Res. Bull. Missouri Agric. Exper. Sta., No. 378.
- MIZUNO, H., AND CHIKAMUNE, T. 1958. The effects of forced weaning on the respiratory activity of mouse mammary gland slice. *Endocrinol. Japon.*, **5**, 265-272.
- MIZUNO, H., IIDA, K., AND NAITO, M. 1955. The role of prolactin in the mammary alveolus formation. *Endocrinol. Japon.*, **2**, 163-169.
- MIZUNO, H., AND NAITO, M. 1956. The effect of locally administered prolactin on the nucleic acid content of the mammary gland in the rabbit. *Endocrinol. Japon.*, **3**, 227-230.
- MOORE, R. O. AND NELSON, W. L. 1952. Some oxidative enzyme systems of mammary gland tissue. *Arch. Biochem.*, **36**, 178-194.
- MOSMANN, W. 1949. Zur Anatomie der Rindermilchdrüse und über die Morphologie ihrer sezernierenden Teile. *Acta anat.*, **8**, 347-378.
- MUNFORD, R. E. 1957. The effect of cortisol acetate on oestrone-induced mammary gland growth in immature ovariectomized albino mice. *J. Endocrinol.*, **16**, 72-79.
- MUNSON, P. L. 1955. Studies on the role of the parathyroids in calcium and phosphorus metabolism. *Ann. New York Acad. Sc.*, **60**, 776-795.
- NANDI, S. 1958a. Role of somatotropin in mammaryogenesis and lactogenesis in C3H/HeCRGL mice. *Science*, **128**, 772-774.
- NANDI, S. 1958b. Endocrine control of mammary-gland development and function in the C3H/HeCRGL Mouse. *J. Nat. Cancer Inst.*, **21**, 1039-1063.
- NELSON, W. O. 1937. Studies on the physiology of lactation. VI. The endocrine influences concerned in the development and function of the mammary gland in the guinea pig. *Am. J. Anat.*, **60**, 341-365.
- OSHIMA, M., AND GOTO, T. 1955. A study of involution of the mammary gland after weaning in the albino rat. *Bull. Nat. Inst. Agric. Sc.*, ser. G, No. II, 81-87.
- ÔTA, K., AND YOKOYAMA, A. 1958. Effect of oxytocin administration on respiration of lactating mammary gland tissue in rats. *Nature*, **182**, 1509-1510.
- PATERSON, J. 1841. On lactation, after-pains and the treatment of females after delivery. *Lancet*, **1**, 246-247.
- PEETERS, G., AND COUSSENS, R. 1950. The influence of the milking act on the diuresis of the lactating cow. *Arch. internat. pharmacodyn.*, **84**, 209-220.
- PETERSEN, W. E. 1944. Lactation. *Physiol. Rev.*, **24**, 340-371.
- PETERSEN, W. E. 1948. The hormonal control of lactation. *Recent Progr. Hormone Res.*, **2**, 133-158.
- PFALTZ, C. R. 1949. Das embryonale und postnatale Verhalten der männlichen Brustdrüse beim Menschen. II. Das Mammarorgan im Kindes-, Jünglings-, Mannes- und Greisenalter. *Acta anat.*, **8**, 293-328.
- PLAGGE, D. W. 1942. Normal development and experimental treatment of the opossum mammary gland primordium. *Proc. Soc. Exper. Biol. & Med.*, **51**, 219-220.
- PLATT, R., AND SEARS, H. T. N. 1956. Reserpine in severe hypertension. *Lancet*, **270**, 401-403.
- [РОБОВИЧ, Д.] РОБОВИЧ, Д. 1958. Роль тирозилазуа в регуляцији моторнои функцији молочной железы. *Dokl. Akad. Nauk S.S.S.R.*, **121**, 186-189.
- POWELL, J. E. 1949. *Herodotus* (IV, 2) Translation. Vol. I. London: Oxford University Press.
- RACADOT, J. 1957. Neurosécrétion et activité thyroïdienne chez la chatte au cours de la gestation et de l'allaitement. *Ann. endocrinol.*, **18**, 628-634.
- RAWLINSON, H. E., AND PIERCE, G. B. 1950. Iron content as a quantitative measurement of the effect of previous pregnancies on the mammary gland of mice. *Endocrinology*, **46**, 426-433.
- RAY, E. W., AVERILL, S. C., LYONS, W. R., AND JOHNSON, R. E. 1955. Rat placental hormonal activities corresponding to those of pituitary mammatropin. *Endocrinology*, **56**, 359-373.
- RAYNAUD, A. 1947a. Effet des injections d'hormones sexuelles à la souris gravide, sur le développement des ébauches de la glande mammaire des embryons. I. Action des substances androgènes. *Ann. endocrinol.*, **8**, 248-253.
- RAYNAUD, A. 1947b. Effet des injections d'hormones sexuelles à la souris gravide, sur le développement des ébauches de la glande mammaire des embryons. II. Action de fortes doses de substances oestrogènes. *Ann. endocrinol.*, **8**, 318-329.
- RAYNAUD, A. 1947c. Observations sur le développement normal des ébauches de la glande mammaire des foetus mâles et femelles de souris. *Ann. endocrinol.*, **8**, 349-359.
- RAYNAUD, A. 1947d. Action des hormones sexuelles sur le développement embryonnaire de la glande mammaire de la souris. *Compt. rend. Soc. Biol.*, **225**, 150-152.
- RAYNAUD, A. 1949a. Nouvelles observations sur l'appareil mammaire des foetus de souris provenant de mères ayant reçu des injections de testostérone pendant la gestation. *Ann. endocrinol.*, **10**, 54-62.
- RAYNAUD, A. 1949b. Morphologie comparée des ébauches mammaires de quelques foetus de rongeurs. *Bull. Soc. zool. France*, **74**, 253-277.
- RAYNAUD, A. 1952. Inhibition du développement des ébauches mammaires de l'embryon de souris, sous l'effet d'une hormone oestrogène injectée directement à l'embryon. *Compt. rend. Soc. Biol.*, **146**, 544-549.
- RAYNAUD, A. 1960. Morphogenesis of the mammary gland. In *Milk: the Mammary Gland, and its Secretion*, S. K. Kon and A. T. Cowie, Eds., Ch. I. New York: Academic Press, Inc.

- RAYNAUD, A., AND FRILLEY, M. 1947. État de développement des ébauches mammaires et du cordon vaginal chez les foetus mâles et femelles de souris, dont les ébauches des glandes génitales ont été détruites par une irradiation au moyen des rayons X, à l'âge de treize jours. *Compt. rend. Acad. Sc.*, **225**, 1380-1382.
- RAYNAUD, A., AND FRILLEY, M. 1949. Le développement embryonnaire de la glande mammaire de la souris après destruction, au moyen des rayons X, des glandes génitales de l'embryon. *Bull. Soc. zool. France*, **74**, 156-159.
- RAYNAUD, A., AND RAYNAUD, J. 1956. La production expérimentale de malformations mammaires chez les foetus de souris, par l'action des hormones sexuelles. *Ann. Inst. Pasteur*, **90**, 39-219.
- RAYNAUD, A., AND RAYNAUD, J. 1957. Sur les modifications précoces apportées par l'hormone oestrogène, dans la structure des ébauches mammaires des foetus de souris. *Bull. Soc. zool. France*, **82**, 204-222.
- READ, M. S., AND MOORE, R. O. 1958. The effect of prolactin on the metabolism of lactating guinea pig mammary tissue. *Arch. Biochem. Biophys.*, **77**, 1-12.
- REECE, R. P. 1950. Effectiveness of estrogens in stimulating duct growth of the mammary glands of rats. *Proc. Soc. Exper. Biol. & Med.*, **73**, 284-285.
- REINEKE, E. P., MEITES, J., CAIRY, C. F., AND HUFFMAN, C. F. 1952. Hormonal induction of lactation in sterile cows. In *Proceedings Annual Meeting American Veterinary Medical Association*, 1952, pp. 325-328. Atlantic City: American Veterinary Medical Association.
- RICHARDSON, K. C. 1949. Contractile tissues in the mammary gland, with special reference to myoepithelium in the goat. *Proc. Roy. Soc. London, ser. B*, **136**, 30-45.
- RICHARDSON, K. C. 1953. Measurements of the total area of secretory epithelium in the lactating mammary gland of the goat. *J. Endocrinol.*, **9**, 170-184.
- RICHTER, J. 1936. Der Einfluss der Kastration auf die Milch- und Fleischleistung der Kühe. *Berl. tier. Wchenschr.*, **277-280**, 293-298.
- RINGLER, I., BECKER, N., AND NELSON, W. L. 1951. Coenzyme A and diphosphopyridine nucleotide in guinea pig mammary tissue. *Arch. Biochem. & Biophys.*, **52**, 348-352.
- ROBERTSON, P. A., AND HAWKER, R. W. 1957. A second oxytocin in the hypothalamus. *Nature, London*, **180**, 343-344.
- SALTER, J., AND BEST, C. H. 1953. Insulin as a growth hormone. *Brit. M. J.*, **2**, 353-359.
- SAWYER, C. H. 1957. Induction of lactation in the rabbit with reserpine. *Anat. Rec.*, **127**, 362.
- SAVAYS, G., REDGATE, E. S., AND ROYCE, P. C. 1958. Hypothalamus, adenohypophysis, and adrenal cortex. *Ann. Rev. Physiol.*, **20**, 243-274.
- SCHARRER, E., AND SCHARRER, B. 1954. Hormones produced by neurosecretory cells. *Recent Progr. Hormone Res.*, **10**, 183-232.
- SCHÄFER, E. A. 1898. Mechanism of the secretion of milk. In *Text Book of Physiology*, E. A. Schäfer, Ed., Vol. 1, pp. 662-668. Edinburgh and London: Pentland.
- SELYE, H. 1934. On the nervous control of lactation. *Am. J. Physiol.*, **107**, 535-538.
- SELYE, H. 1954. The effect of cortisol upon the mammary glands. *Acta endocrinol.*, **17**, 394-401.
- SELYE, H., COLLIP, J. B., AND THOMSON, D. L. 1934. Nervous and hormonal factors in lactation. *Endocrinology*, **18**, 237-248.
- SHAW, J. C. 1955. See Discussion, p. 486-492 in Folley, 1955.
- SHAW, J. C., CHUNG, A. C., AND BUNTING, I. 1955. The effect of pituitary growth hormone and adrenocorticotrophic hormone on established lactation. *Endocrinology*, **56**, 327-334.
- SHIMIZU, H. 1957. Biochemical studies on the mammary gland functions. I. The determination of nucleic acids in the mammary glands of rats. *Tohoku J. Agric. Res.*, **7**, 339-345.
- SHORT, R. H. D. 1950. Alveolar epithelium in relation to growth of the lung. *Phil. Tr. Roy. Soc. London, ser. B*, **235**, 35-86.
- SILVER, I. A. 1954. Myoepithelial cells in the mammary and parotid glands. *J. Physiol.*, **125**, 8P-9P.
- SILVER, I. A. 1956. Vascular changes in the mammary gland during engorgement with milk. *J. Physiol.*, **133**, 65P-66P.
- SILVER, M. 1953a. A quantitative analysis of the role of oestrogen in mammary development in the rat. *J. Endocrinol.*, **10**, 17-34.
- SILVER, M. 1953b. The onset of allometric mammary growth in the female hooded Norway rat. *J. Endocrinol.*, **10**, 35-45.
- SMITH, P. E. 1932. The nonessentiality of the posterior hypophysis in parturition. *Am. J. Physiol.*, **99**, 345-348.
- SMITH, T. C., AND RICHTERICH, B. 1958. Synergism of estrogen and progesterone on mammary gland growth in guinea pigs. *Endocrinology*, **63**, 89-98.
- SMITH, V. R., AND PETERSEN, W. E. 1945. Negative pressure and nursing by calves. *J. Dairy Sci.*, **28**, 431-433.
- SMITH, W. T. 1844. Lactation and after-pains, considered in relation to reflex motor action. *Lancet*, **1**, 127-128.
- SORANUS. — *Soranus' Gynecology*, transl. by O. Timkin. 1956. Baltimore: Johns Hopkins Press.
- SPEERT, H. 1948. The normal and experimental development of the mammary gland of the rhesus monkey, with some pathological correlations. *Contr. Embryol., Carnegie Inst. Washington*, **32**, 9-65.
- STRICKER, P., AND GRUETER, F. 1928. Action du lobe antérieur de l'hypophyse sur la montée lacteuse. *Comp. rend. Soc. biol.*, **99**, 1978-1980.
- STRICKER, P., AND GRUETER, F. 1929. Recherches

- expérimentales sur les fonctions du lobe antérieur de l'hypophyse: influence des extraits du lobe antérieur sur l'appareil genital de la lapine et sur la montée laiteuse. *Presse méd.*, **37**, 1268-1271.
- SULMAN, F. G., AND WINNIK, H. Z. 1956. Hormonal effects of chlorpromazine. *Lancet*, **270**, 161-162.
- SYKES, J. F., AND WRENN, T. R. 1950. Hormonal development of the mammary gland of dairy heifers. *J. Dairy Sc.*, **33**, 194-204.
- SYKES, J. F., AND WRENN, T. R. 1951. Hormonal development of mammary tissue in dairy heifers. *J. Dairy Sc.*, **34**, 1174-1179.
- TINDAL, J. S. 1956a. The effect of ergotamine and dihydroergotamine on lactation in the rat. *J. Endocrinol.*, **14**, 268-274.
- TINDAL, J. S. 1956b. National Institute for Research in Dairying, Report 1956, pp. 56-57.
- TINDAL, J. S. 1958. National Institute for Research in Dairying, Report 1958, pp. 48-49.
- TINDAL, J. S. 1960. A breed difference in the lactogenic response of the rabbit to reserpine. *J. Endocrinol.*, **20**, 78-81.
- THÖLÉN, H. 1949. Das Embryonale und Postnatale Verhalten der Männlichen Brustdrüse beim Menschen. I. Das mammarorgan beim Embryo und Säugling. *Acta anat.*, **8**, 201-235.
- TOVERUP, S. V., AND MUNSON, P. L. 1956. The influence of the parathyroids on the calcium concentration of milk. *Ann. New York Acad. Sc.*, **64**, 336.
- TRENTIN, J. J., AND TURNER, C. W. 1947. Effect of adrenalectomy on the mammary gland of the castrated and estrogen treated castrated male rat. *Endocrinology*, **41**, 127-131.
- TRENTIN, J. J., AND TURNER, C. W. 1948. The experimental development of the mammary gland with special reference to the interaction of the pituitary and ovarian hormones. *Res. Bull. Missouri Agric. Exper. Sta.*, No. 418.
- [TSAKHAEV, G. A.] Цахаев, Г. А. 1953. О природе аферентных путей рефлекса молокоотдачи. *Dokl. Akad. Nauk S.S.S.R.*, **93**, 941-944.
- [TSAKHAEV, G. A.] Цахаев, Г. А. 1959. Секреторная функция молочной железы в условиях денервации гипофиза. In *Вопросы физиологии сельскохозяйственных животных*, M. G. Zaks, Ed., pp. 3-19. Vilnius, Kaunas: Akademiya Nauk Litovsk. S.S.R.
- TURNER, C. W. 1939. The mammary glands. In *Sex and Internal Secretions*, 2nd ed., E. Allen, C. H. Danforth and E. A. Doisy, Eds., Ch. XI. Baltimore: The Williams & Wilkins Company.
- TURNER, C. W. 1952. *The Mammary Gland*, Vol. I. The Anatomy of the Udder of Cattle and Domestic Animals. Columbia, Mo.: Lucas Bros.
- TURNER, C. W., AND GOMEZ, E. T. 1933. The normal development of the mammary gland of the male and female albino mouse. *Res. Bull. Missouri Agric. Exper. Sta.*, No. 182.
- TURNER, C. W., AND GOMEZ, E. T. 1934. The experimental development of the mammary gland. II. The male and female guinea pig. *Res. Bull. Missouri Agric. Exper. Sta.*, No. 206.
- TURNER, C. W., AND SCHULTZE, A. B. 1931. A study of the causes of the normal development of the mammary gland of the albino rat. *Res. Bull. Missouri Agric. Exper. Sta.*, No. 157.
- TURNER, C. W., AND SLAUGHTER, I. S. 1930. The physiological effect of pituitary extract (posterior lobe) on the lactating mammary gland. *J. Dairy Sc.*, **13**, 8-24.
- [TVERSKOĬ, G. B.] Тверской, Г. Б. 1953. О природе чувствительных стимулов с вымени, участвующих в рефлекторной регуляции секреции молока. *Zhur. Obshchei Biol.*, **11**, 349-359.
- [TVERSKOĬ, G. B.] Тверской, Г. Б. 1957. О роли чувствительной иннервации молочной железы в рефлекторной регуляции секреции молока и молочного жира. *Zhur. Obshchei Biol.*, **18**, 169-184.
- [TVERSKOĬ, G. B.] Тверской, Г. Б. 1958. Секреция молока у коз после полной перерезки пищевого мозга. *Dokl. Akad. Nauk S.S.S.R.*, **123**, 1137-1139.
- TVERSKOY, G. B. 1960. Influence of cervical sympathectomy and pituitary stalk section upon milk secretion in goats. *Nature, London*, **186**, 782-784.
- VAN WAENEN, G., AND FOLLEY, S. J. 1939. The effect of androgens on the mammary gland of the female rhesus monkey. *J. Endocrinol.*, **1**, 367-372.
- VENDRELY, R. 1955. The deoxyribonucleic acid content of the nucleus. In *The Nucleic Acids: Chemistry and Biology*, E. Chargaff and J. N. Davidson, Eds., Ch. 19, pp. 155-180. New York: Academic Press, Inc.
- VOX BERSWORTD-WALLRABE, R. 1958. Versuch einer theoretischen Erklärung der Hemmung der Galaktopoese der Albinomaus durch Dienöstroldiacetat. *Arch. Gynäk.*, **190**, 619-637.
- WALKER, S. M., AND MATTHEWS, J. I. 1949. Observations on the effects of prepartal and postpartal estrogen and progesterone treatment on lactation in the rat. *Endocrinology*, **44**, 8-17.
- WALLER, H. 1938. *Clinical Studies in Lactation*. London: William Heinemann, Ltd.
- WHITTLESTONE, W. G. 1954. Intra mammary pressure changes in the lactating sow. III. The effects of level of dose of oxytocin and the influence of rate of injection. *J. Dairy Res.* **21**, 188-193.
- WILLIAMS, W. L. 1942. Normal and experimental mammary involution in the mouse as related to the inception and cessation of lactation. *Anat. Rec.*, **71**, 1-41.
- WILLIAMS, W. L. 1945. The effects of lactogenic hormone on the postparturient unsuckled mammary glands of the mouse. *Anat. Rec.*, **93**, 171-183.

- WILLIAMS, V. L., AND STEWART, C. A. 1945. Mammary development in the newborn human. *Endocrinol. Rec.*, **91**, 307-308.
- YAMA, A. 1956. Milk-ejection responses following administration of "tap" stimuli and posterior-pituitary extracts. *Endocrinol. Japon.*, **3**, 32-38.
- [ZAKS, M. G.] Заке, М. Г. 1951. Новые данные о функции моторного аппарата вымени. IX Сборник Докладов Второй Всесоюзной Конференции по Молочному Делу. R. B. Davidov, 2d. p. 150-163. Moscow: Sel'khozgiz.
- [ZAKS, M. G.] Заке, М. Г. 1958. Физиология двигательного аппарата молочной железы сельскохозяйственных животных. Moscow, Leningrad: Akademiya Nauk, S.S.S.R.
- ZIETZSCHMANN, O. 1926. Bau und Funktion der Milchdrüse. In *Lehrbuch der Chemie und Physiologie der Milch*, 2nd ed., W. Grimmer, Ed., p. 1-35. Berlin: Paul Parey.

# SOME PROBLEMS OF THE METABOLISM AND MECHANISM OF ACTION OF STEROID SEX HORMONES

*Claude A. Villee, Ph.D.*

ASSOCIATE PROFESSOR OF BIOLOGICAL CHEMISTRY,  
HARVARD UNIVERSITY

I. INTRODUCTION.....	643
II. THE BIOSYNTHESIS OF STEROIDS.....	643
A. Cholesterol.....	644
B. Progesterone.....	644
C. Androgens.....	645
D. Estrogens.....	647
E. Biosynthesis of Other Steroids.....	647
F. Interconversions of Steroids.....	647
G. Catabolism of Steroids.....	648
H. Transport, Conjugation, and Excretion.....	650
III. EFFECTS OF SEX HORMONES ON INTER-MEDIARY METABOLISM.....	650
A. Estrogens.....	652
B. Androgens.....	659
C. Progesterone.....	660
IV. REFERENCES.....	661

## I. Introduction

The chemical structure of the sex hormones, their isolation from biologic materials, and many of their chemical properties were fully described in the previous edition of *Sex and Internal Secretions* (W. M. Allen, 1939; Doisy, 1939; Koch, 1939). The major steroid sex hormones were isolated and identified 20 to 30 years ago. Estrone, in fact, was crystallized from pregnancy urine by Doisy, Veler and Thayer (1929) before the true structure of the steroid nucleus was known. The isolation, identification, and chemical synthesis of estradiol, progesterone, and testosterone were accomplished during the 1930's. Additional substances with androgenic, estrogenic, or progestational activity have subsequently been isolated from urine or from tissues but these are probably metabolites of the major

sex steroids. The steroids are now routinely synthesized from cholesterol or from plant sterols. It would be possible to carry out the total synthesis of steroids from simple precursors but this is not commercially practicable.

The two decades since the previous edition have been marked by major advances in our understanding of the intermediary metabolism of steroids—the synthesis of cholesterol from two-carbon units, the conversion of cholesterol to pregnenolone and progesterone, and the derivation of corticoids, androgens, and estrogens from progesterone. These advances were made possible by the development of vastly improved methods for the isolation and identification of steroids: chromatography on paper or columns, counter-current distribution, labeling with radioactive or heavy isotopes, infrared spectroscopy, and so on. There have been concomitant increases in the information regarding the sites and mechanisms of action of these biologically important substances and the means by which they stimulate or inhibit the growth and activity of particular tissues of the body. The following discussion will attempt to present a general picture of these two fields and not an exhaustive citation of the tremendous body of relevant literature.

## II. The Biosynthesis of Steroids

When the steroid hormones were first discovered it was generally believed that each

endocrine gland made its characteristic steroid by some unique biosynthetic mechanism, one that was independent of those in other glands. However, there is now abundant evidence that the biosynthetic paths in the several steroid-secreting glands have many features which are similar or identical.

It is now well established that progesterone is not simply a female sex hormone produced by the corpus luteum, but a common precursor of adrenal glucocorticoids such as cortisol and adrenal mineralocorticoids such as aldosterone, androgens, and estrogens. The adrenal cortex, ovary, testis, and placenta have in common many enzymes for the biosynthesis of steroids. Androgenic tumors of the human ovary, for example, have been shown to produce testosterone and its metabolites. The transplantation of an ovary into a castrate male mouse will result in the maintenance of the male secondary sex characters, which suggests that the normal ovary can also synthesize androgens.

#### A. CHOLESTEROL

The early work of Bloch (1951), Rilling, Tchen and Bloch (1958), and of Popják (1950) showed that labeled acetate is converted to labeled cholesterol. The pattern of the labeling present in the cholesterol synthesized from acetate-1-C<sup>14</sup> or acetate-2-C<sup>14</sup> as precursor led to speculations as to how the steroid nucleus is assembled. Further work (Langdon and Bloch, 1953) revealed that squalene and certain branched-chain, unsaturated fatty acids are intermediates in this synthesis. The current hypothesis, which is supported by a wealth of experimental evidence, states that two moles of acetyl coenzyme A condense to form acetoacetyl coenzyme A, which condenses with a third molecule of acetyl coenzyme A to form  $\beta$ -hydroxy- $\beta$ -methyl glutaric acyl coenzyme A (Fig. 11.1). The coenzyme A group is removed and the hydroxymethyl glutaric acid is reduced to mevalonic acid. Mevalonic acid, 3-hydroxy-3-methylpentano-5-lactone, is metabolized to a 5-carbon isoprenoid compound and three moles of these condense to form a 15-carbon hydrocarbon. The head-to-head condensation of two molecules of this 15-carbon compound yields the 30-

carbon equalene. This is metabolized, by way of lanosterol and the loss of three methyl groups, to cholesterol, which seems to be the common precursor of all of the steroid hormones (Tchen and Bloch, 1955; Clayton and Bloch, 1956).

The question of whether cholesterol is an obligate intermediate in the synthesis of steroid hormones has not been definitely answered. There is clear evidence that cholesterol is converted to steroids without first being degraded to small units and subsequently reassembled. Werbin and LeRoy (1954) administered cholesterol labeled with both carbon-14 and tritium (H<sup>3</sup>) to human subjects and isolated from their urine tetrahydrocortisone, tetrahydrocortisol, androsterone, etiocholanolone and 11-ketotiocholanolone. These substances, known to be metabolites of steroid hormones, were labeled with both C<sup>14</sup> and H<sup>3</sup> and the labeled atoms were present in the ratio expected if they were derived directly from cholesterol. Experiments by Dorfman and his colleagues (Caspi, Rosenfeld and Dorfman, 1956) also provide evidence for the synthesis of steroids via cholesterol. Cortisol and 11-desoxycortisol were isolated from calf adrenals perfused with acetate-1-C<sup>14</sup> and from a patient with an adrenal tumor to whom acetate-1-C<sup>14</sup> had been administered. It is known that cholesterol synthesized from acetate-1-C<sup>14</sup> is labeled in carbon 20 but not in carbon 21. The cortisol and 11-desoxycortisol also proved to be labeled in carbon 20 but not in carbon 21. This evidence does not, of course, exclude biosynthetic paths for the steroids other than one by way of cholesterol, but it does suggest that cholesterol is at least an important precursor of them. Direct evidence that cholesterol is synthesized from squalene in man is provided by the experiments of Eidinoff, Knoll, Marano, Kvamme, Rosenfeld and Hellman (1958), who prepared tritiated squalene and administered it orally to human subjects. They found that the cholesterol of the blood achieved maximal specific activity in 7 to 21 hours.

#### B. PROGESTERONE

Cholesterol undergoes an oxidative cleavage of its side chain to yield isocaproic acid and pregnenolone (Fig. 11.2). The lat-



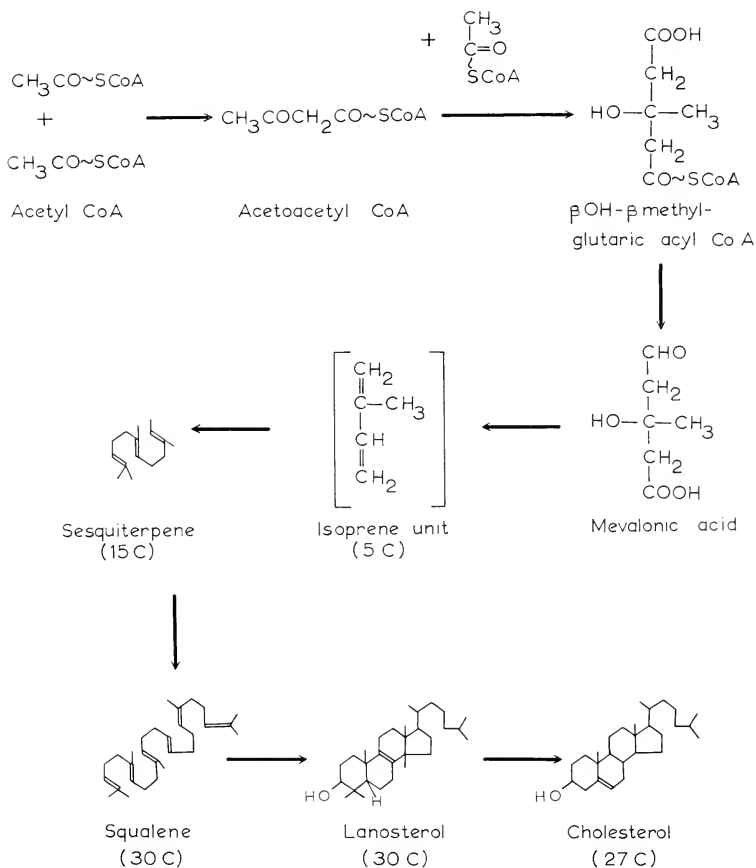

Fig. 11.1. Biogenesis of cholesterol.

ter is dehydrogenated in ring A by the enzyme 3-β-ol dehydrogenase and a spontaneous shift of the double bond from the Δ5,6 to the Δ4,5 position results in progesterone. Progesterone undergoes successive hydroxylation reactions, which require molecular oxygen and reduced triphosphopyridine nucleotide (TPNH), at carbons 17, 21, and 11. These hydroxylations yield, in succession, 17-α-hydroxyprogesterone, Reichstein's compound S (11-desoxy-17-hydroxycorticosterone), and cortisol (17-α-hydroxycorticosterone).

C. ANDROGENS

17-α-Hydroxyprogesterone is also the immediate precursor of androgens and estrogens. Oxidative cleavage of its side chain yields Δ-4-androstenedione, which undergoes reduction to testosterone (Fig. 11.2). Δ-4-Androstenedione may be hydroxylated at carbon 11 to yield 11-β-hydroxy-Δ-4-androstenedione, which is an androgen isolated from human urine. It has also been found as a metabolite of certain androgenic tumors of the adrenal cortex.

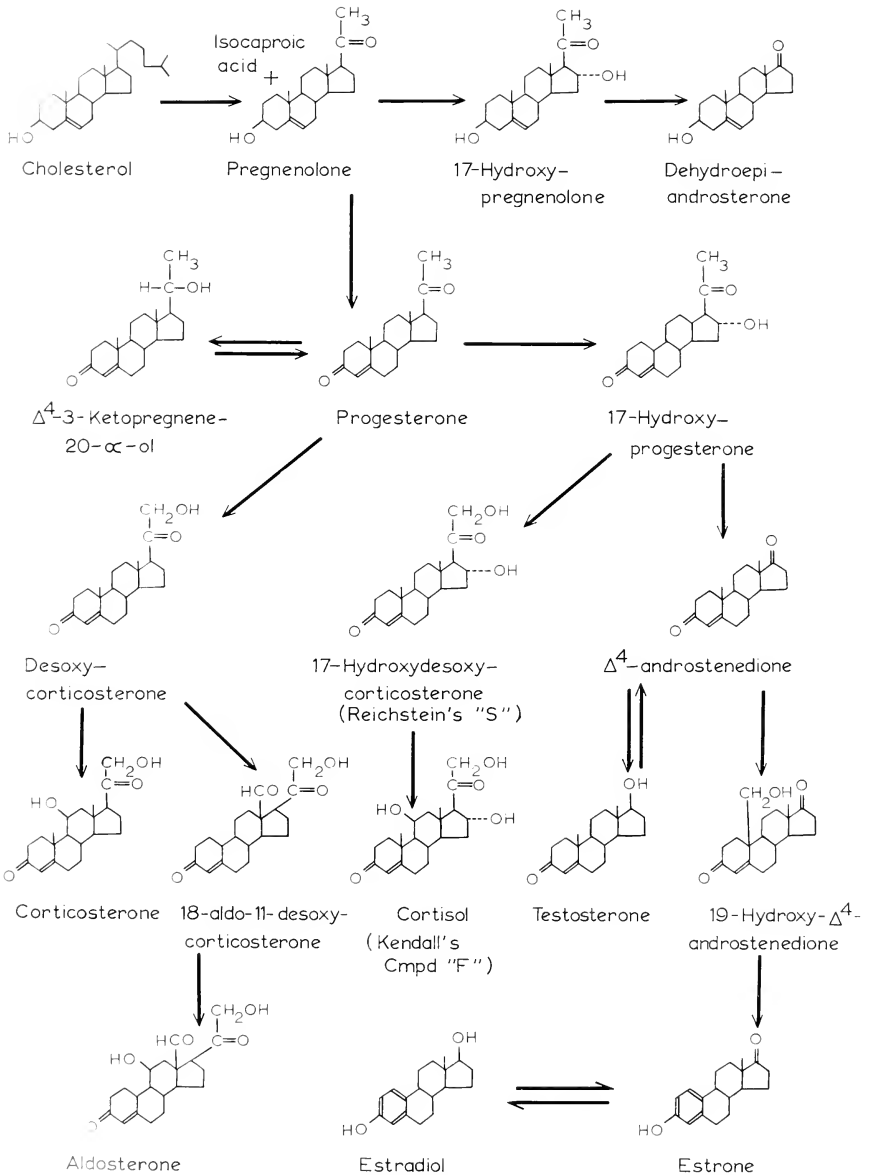

Fig. 11.2. Biosynthetic paths from cholesterol.

## D. ESTROGENS

$\Delta$ -4-Androstenedione and testosterone are precursors of the estrogens. Baggett, Engel, Savard and Dorfman (1956) demonstrated the conversion of testosterone to estradiol-17 $\beta$  by slices of human ovary. Ryan (1958) found that the enzymes to carry out this conversion are also present in the human placenta, located in the microsomal fraction of placental homogenates. Homogenates of stallion testis convert labeled testosterone to labeled estradiol and estrone. Slices of human adrenal cortical carcinoma also have been shown to convert testosterone to estradiol and estrone, and Nathanson, Engel and Kelley (1951) found an increased urinary excretion of estradiol, estrone, and estrinol following the administration of adrenocorticotrophic hormone to castrate women. Thus it seems that ovary, testis, placenta, and adrenal cortex have a similar biosynthetic mechanism for the production of estrogens and androgens. The first step in the conversion of testosterone or  $\Delta$ -4-androstenedione to estrogens is the hydroxylation at carbon 19, again by an enzymatic process which requires molecular oxygen and TPNH. Meyer (1955) first isolated and characterized 19-hydroxy- $\Delta$ -4-androstene-3,17-dione from a perfused calf adrenal. When this was incubated with dog placenta it was converted to estrone. The steps in the conversion of the 19-hydroxy- $\Delta$ -4-androstenedione to estrone appear to be the introduction of a second double bond into ring A, the elimination of carbon 19 as formaldehyde, and rearrangement to yield a phenolic ring A. The requirements for the aromatization of ring A by a microsomal fraction of human placenta were studied by Ryan (1958). West, Damast, Sarro and Pearson (1956) found that the administration of testosterone to castrated, adrenalectomized women resulted in an increased excretion of estrogen. This suggests that tissues other than adrenals and gonads, presumably the liver, can carry out this same series of reactions.

## E. BIOSYNTHESIS OF OTHER STEROIDS

To complete the picture of the interrelations of the biosyntheses of steroids, it should be noted that other evidence shows

that progesterone is hydroxylated at carbon 21 to yield desoxycorticosterone and this is subsequently hydroxylated at carbon 11 to yield corticosterone. Desoxycorticosterone may undergo hydroxylation at carbon 18 and at carbon 11 to yield aldosterone, the most potent salt-retaining hormone known (Fig. 11.2).

Dehydroepiandrosterone is an androgen found in the urine of both men and women. Its rate of excretion is not decreased on castration and it seems to be synthesized only by the adrenal cortex. It has been postulated that pregnenolone is converted to 17-hydroxypregnenolone and that this, by cleavage of the side chain between carbon 17 and carbon 20, would yield dehydroepiandrosterone.

## F. INTERCONVERSIONS OF STEROIDS

The interconversion of estrone and estradiol has been shown to occur in a number of human tissues. A diphosphopyridine nucleotide-linked enzyme, estradiol-17 $\beta$  dehydrogenase, which carries out this reaction has been prepared from human placenta and its properties have been described by Langer and Engel (1956). The mode of formation of estriol and its isomer, 16-epiestriol, is as yet unknown.

There are three major types of reactions which occur in the interconversions of the steroids: dehydrogenation, "hydroxylation," and the oxidative cleavage of the side chain. An example of a dehydrogenation reaction is the conversion of pregnenolone to progesterone by the enzyme 3- $\beta$ -ol dehydrogenase, which requires diphosphopyridine nucleotide (DPN) as hydrogen acceptor. This important enzyme, which is involved in the synthesis of progesterone and hence in the synthesis of all of the steroid hormones, is found in the adrenal cortex, ovary, testis, and placenta. Other dehydrogenation reactions in which DPN is the usual hydrogen acceptor are the readily reversible conversions of  $\Delta$ -4-androstenedione  $\rightleftharpoons$  testosterone, estrone  $\rightleftharpoons$  estradiol, and progesterone  $\rightleftharpoons$   $\Delta$ -4-3-ketopregnene-20- $\alpha$ -ol. This latter substance, and the enzymes producing it from progesterone, have been found by Zander (1958) in the human corpus luteum and placenta.

The oxidative reactions leading to the

introduction of an OH group on the steroid nucleus are usually called "hydroxylations." Specific hydroxylases for the introduction of an OH group at carbons 11, 16, 17, 21, 18, and 19 have been demonstrated. All of these require molecular oxygen and a reduced pyridine nucleotide, usually TPNH. The 11- $\beta$ -hydroxylase of the adrenal cortex has been shown to be located in the mitochondria (Hayano and Dorfman, 1953). Experiments with this enzyme system, utilizing oxygen 18, showed that the oxygen atoms are derived from gaseous oxygen and not from the oxygen in the water molecules (Hayano, Lindberg, Dorfman, Hancock and Doering, 1955). Thus this hydroxylation reaction also involves the reduction of molecular oxygen.

The oxidative cleavage of the side chains of the steroid molecule appears to involve similar hydroxylation reactions. The experiments of Solomon, Levitan and Lieberman (1956) indicate that the conversion of cholesterol to pregnenolone involves one and possibly two of these hydroxylation reactions, with the introduction of OH groups at carbons 20 and 22 before the splitting off of the isocaproic acid.

In summary, this newer knowledge of the biosynthetic paths of steroids has revealed that the differences between the several steroid-secreting glands are largely quantitative rather than qualitative. The testis, for example, produces progesterone and estrogens in addition to testosterone. The change from the secretion of estradiol by the follicle to the secretion of progesterone by the corpus luteum can be understood as a relative loss of activity of an enzyme in the path between progesterone and estradiol. If, for example, the enzyme for the 17-hydroxylation of progesterone became inactive as the follicle cells are changed into the corpus luteum, progesterone rather than estradiol would subsequently be produced.

Knowledge of these pathways also provides an explanation for certain abnormal changes in the functioning of the glands. Bongiovanni (1953) and Jailer (1953) showed that the adrenogenital syndrome results from a loss of an enzyme or enzymes for the hydroxylation reactions at carbons 21 and 11 of progesterone, which results in an impairment in the production of cortisol.

The pituitary, with little or no cortisol to inhibit the secretion of adrenocorticotrophic hormone (ACTH), produces an excess of this hormone which stimulates the adrenal to produce more steroids. There is an excretion of the metabolites of progesterone and 17-hydroxyprogesterone, pregnanediol and pregnanetriol respectively, but some of the 17-hydroxyprogesterone is converted to androgens and is secreted in increased amount.

#### G. CATABOLISM OF STEROIDS

Many of the steroid hormones are known to act on the pituitary to suppress its secretion of the appropriate trophic hormone, ACTH, the follicle-stimulating hormone (FSH), or luteinizing hormone (LH). It would seem that the maintenance of the proper feedback mechanism between steroid-secreting gland and pituitary requires that the steroids be continuously inactivated and catabolized. The catabolic reactions of the steroids are in general reductive in nature and involve the reduction of ketonic groups and the hydrogenation of double bonds. The reduction of a ketonic group to an OH group can lead to the production of two different stereoisomers. If the OH group projects from the steroid nucleus on the same side as the angular methyl groups at carbon 18 and carbon 19, *i.e.*, above the plane of the four rings, it is said to have the  $\beta$ -configuration and is represented by a heavy line. If the OH projects on the opposite side of the steroid nucleus, below the plane of the four rings, it is said to have the  $\alpha$ -configuration and is represented by a dotted line. Although both isomers are possible, usually one is formed to a much greater extent than the other.

The first catabolic step is usually the reduction of the  $\Delta^4$ -3-ketone group of ring A, usually to 3 $\alpha$ OH compounds with the hydrogen at carbon 5 attached in the  $\beta$ -configuration. The 5 $\beta$ -configuration represents the *cis* configuration of rings A and B. The elimination of the  $\Delta^4$ -3-ketone group greatly decreases the biologic activity of the steroid and increases somewhat its solubility in water. This reductive process occurs largely in the liver. Progesterone is converted by reduction of its  $\Delta^4$ -3-ketone group to pregnane-3 $\alpha$ :20 $\alpha$ -diol, and 17-hy-

EXCRETORY PRODUCTS

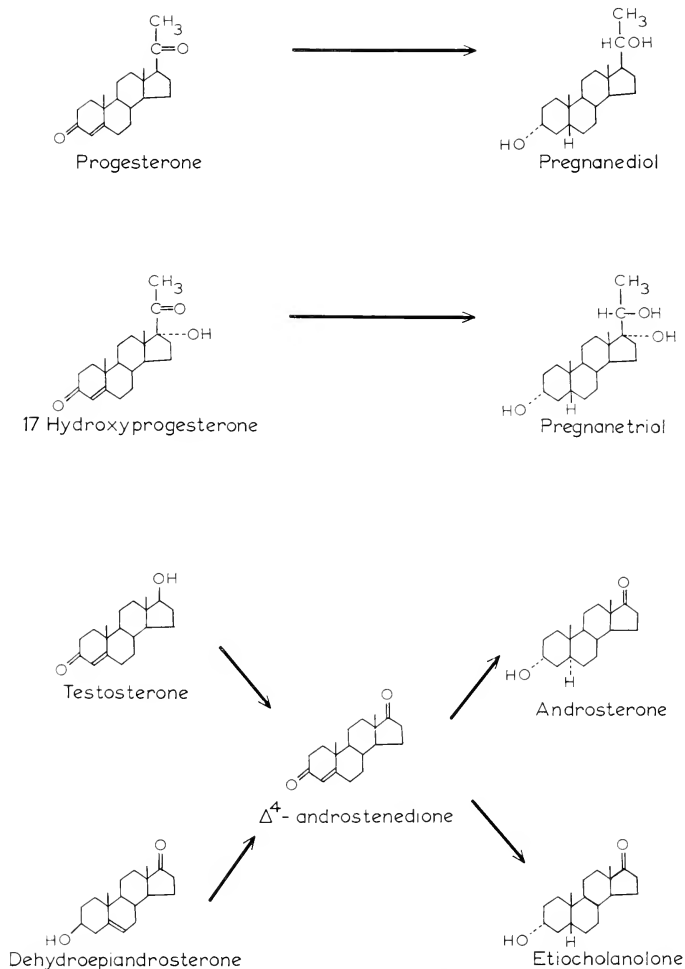

FIG. 11.3. Excretory products of progesterone and androgens.

droxyprogesterone is converted to pregnane- $3\alpha:17\alpha:20\alpha$ -triol (Fig. 11.3). Testosterone and dehydroepiandrosterone are both converted to  $\Delta^4$ -androstenedione and the reduction of its  $\Delta^4$ -3-ketone group results in a mixture of androsterone ( $3\alpha,5\alpha$ -configuration) and etiocholanolone ( $3\alpha,5\beta$ -configuration).

The catabolism of estradiol is not completely known. Estradiol, estrone, and estratriol are found in the urine but they account for less than half of an administered dose of labeled estradiol. The  $\beta$ -isomer,  $16\beta$ -epiestriol, and two other phenolic steroids,  $16\alpha$ -hydroxy estrone and 2-methoxyestrone, have recently been isolated from normal

urine and are known to be estrogen metabolites (Marrian and Bauld, 1955).

#### 12. TRANSPORT, CONJUGATION, AND EXCRETION

Steroids circulate in the blood in part as free steroids and in part conjugated with sulfate or glucuronic acid (cf. review by Roberts and Szego, 1953b). The steroids are generally conjugated by the hydroxyl group at carbon 3 with inorganic sulfate or with glucuronic acid. In addition, either the conjugated or nonconjugated forms may be bound to certain of the plasma proteins such as the  $\beta$ -globulins (Levedahl and Bernstein, 1954). There is evidence of specific binding of certain steroids with particular proteins, e.g., the binding of cortisol to "transcortin" (Daughaday, 1956). Between 50 and 80 per cent of the estrogens in the blood are present closely bound to plasma proteins. A similar large fraction of the other steroid hormones is bound to plasma proteins; presumably this prevents the hormone from being filtered out of the blood as it passes through the glomerulus of the kidney. The steroids excreted in the urine are largely in the conjugated form, as sulfates or glucuronides.

The liver plays a prime role in the catabolism of the steroids. It is the major site of the reductive inactivation of the steroids and their conjugation with sulfate or glucuronic acid. These conjugated forms are more water-soluble and the conjugation probably promotes their excretion in the urine. Rather large amounts of certain steroids, notably estrogens, are found in the bile of certain species. These estrogens are free, not conjugated; the amount of estrogens present in the bile suggests that this is an important pathway by which they are excreted. It has been suggested that the bacteria of the gastrointestinal tract may degrade the steroids excreted in the bile and further that there is an "enterohepatic circulation" of steroids with reabsorption from the gut, transport in the portal system to the liver, and further degradation within the liver cells.

### III. Effects of Sex Hormones on Intermediary Metabolism

The literature concerning the effects of hormones on intermediary metabolism is

voluminous and contains a number of contradictions, some of which are real and some, perhaps, are only apparent contradictions. Evidence that a hormone acts at one site does not necessarily contradict other evidence that that hormone may act on a different metabolic reaction. From the following discussion it should become evident that there may be more than one site of action, and more than one mechanism of action, of any given hormone.

The hormones are so different in their chemical structure, proteins, peptides, amino acids, and steroids, that it would seem unlikely, *a priori*, that they could all influence the cellular machinery by comparable means. The basic elements of an enzyme system are the protein enzyme, its cofactors and activators, and the substrates and products. A hormone might alter the over-all rate of an enzyme system by altering the amount or activity of the protein enzyme, or by altering the availability to the enzyme system of some cofactor or substrate molecule. Some of the mechanisms of hormone action which have been proposed are these. (1) The hormone may alter the rate at which enzyme molecules are produced *de novo* by the cell. (2) The hormone may alter the activity of a preformed enzyme molecule, i.e., it may convert an inactive form of the enzyme to an active form. (3) The hormone may alter the permeability of the cell membrane or the membrane around one of the subcellular structures within the cell and thus make substrate or cofactor more readily available to the enzyme. Or, (4) the hormone may serve as a coenzyme in the system, that is, it may be involved in some direct fashion as a partner in the reaction mediated by the enzyme. Each of these theories has been advanced to explain the mode of action of the sex hormones.

The problem of the hormonal control of metabolism has been investigated at a variety of biologic levels. The earliest experiments were done by injecting a hormone into an intact animal and subsequently measuring the amount of certain constituents of the blood, urine, or of some tissue. There are several difficulties with such experiments. All of the homeostatic mechanisms of the animal operate to keep condi-

tions constant and to minimize the effects of the injected hormone. In addition, there is a maze of interactions, some synergistic and some antagonistic, between the different hormones both in the endocrine gland and in the target organs, so that the true effect of the substance injected may be veiled. Our growing understanding of the interconversions of the steroid hormones warns us that an androgen, for example, may be rapidly converted into an estrogen, and the metabolic effects observed on the administration of an androgen may, at least in part, result from the estrogens produced from the injected androgen.

To eliminate some of the confusing effects of these homeostatic mechanisms some investigators remove the liver, kidneys, and other viscera before injecting the hormone under investigation. Such eviscerated preparations have been used by Levine and his colleagues in their investigations of the mode of action of insulin (*cf.* Levine and Goldstein, 1955).

Other investigators have incubated slices of liver, kidney, muscle, endocrine glands, or other tissues in glass vessels in a chemically defined medium and at constant temperature. Such experiments have the advantage that metabolism can be studied more directly, oxygen consumption and carbon dioxide production can be measured manometrically, and aliquots of the incubation medium can be withdrawn for chemical and radiochemical analyses. The amounts of substrate, cofactors, and hormone present can be regulated and the interfering effects of other hormones and of other tissues are eliminated. Theoretically, working with a simpler system such as this should lead to greater insight into the physiologic and chemical events that occur when a hormone is added or deleted. The chief disadvantage of this experimental system is that it is difficult to prove that the conditions of the experiment are "physiologic." With tissue slices there is the possibility that the cut edges of the cells may introduce a sizeable artifact. Kipnis and Cori (1957) found that the rat diaphragm, as it is usually prepared for experiments *in vitro*, has an abnormally large extracellular space and is more permeable to certain pentoses than is the intact diaphragm.

It has been postulated that a hormone may influence the metabolism of a particular cell by altering the permeability of the cell membrane or of the membrane around one of the subcellular particles. Experiments with tissue homogenates, in which the cell membrane has been ruptured and removed, provide evidence bearing on such theories. If an identical hormone effect can be obtained in a cell-free system, and if suitable microscopic controls show that the system is indeed cell-free, the permeability theory may be ruled out.

Ideally the hormone effect should be studied in a completely defined system, with a single crystalline enzyme, known concentration of substrates and cofactors, and with known concentration of the pure hormone. Colowick, Cori and Stein (1947) reported that hexokinase extracted from diabetic muscle has a lower rate of activity than hexokinase from normal muscle and that it could be raised to the normal rate by the addition of insulin *in vitro*. The reality of this effect has been confirmed by some investigators and denied by others who were unable to repeat the observations. Cori has suggested that the decreased rate of hexokinase activity in the diabetic results from a labile inhibitor substance produced by the pituitary. Krahl and Bornstein (1954) have evidence that this inhibitor is a lipoprotein which is readily inactivated by oxidation.

The two hormones whose effects can be demonstrated reproducibly in an *in vitro* system at concentrations in the range which obtains in the tissues are epinephrine (or glucagon) and estradiol (and other estrogens). Epinephrine or glucagon stimulates the reactivation of liver phosphorylase by increasing the concentration of adenosine-3'-5'-monophosphate (Haynes, Sutherland and Rall, 1960), and estrogens stimulate an enzyme system found in endometrium, placenta, ventral prostate of the rat, and mammary gland. The estrogen-stimulable enzyme was originally described as a DPN-linked isocitric dehydrogenase, but the estrogen-sensitive enzyme now appears to be a transhydrogenase which transfers hydrogens from TPX to DPN (Talakay and Williams-Ashman, 1958; Villet and Hagerman, 1958).

The various tissues of the body respond in quite different degrees to the several hormones. This difference in response is especially marked with the sex hormones. Those tissues which respond dramatically to the administration of a hormone are termed the "target organs" of that hormone. Just what, at the cellular level, differentiates a target organ from the other tissues of the body is not known exactly but there is evidence that each kind of tissue is characterized by a certain pattern of enzymes. The pattern of enzymes is established, by means as yet unknown, in the course of embryonic differentiation. The enzyme glucose 6-phosphatase, which hydrolyzes glucose 6-phosphate and releases free glucose and inorganic phosphate, is present in liver but absent from skeletal muscle. Even though a given reaction in two different tissues may be mediated by what appears to be the same enzyme, the enzymes may be different and subject to different degrees of hormonal control. Henion and Sutherland (1957) showed that the phosphorylase of liver responds to glucagon but the phosphorylase of heart muscle does not. Further, the two enzymes are immunologically distinct. An antiserum to purified liver phosphorylase will not react with heart phosphorylase to form an inactive antigen-antibody precipitate, but it does react in this manner with liver phosphorylase. Further, perhaps more subtle, differences between comparable enzymes from different tissues have appeared when lactic dehydrogenases from liver, heart, skeletal muscle, and other sources were tested for their rates of reaction with the several analogues of the pyridine nucleotides now available (Kaplan, Ciotti, Hamolsky and Bieber, 1960). Extension of this technique may reveal differences in response to added hormones.

In addition to these differences in the response to a hormone of the tissues of a single animal, there may be differences in the response of the comparable tissues of different species to a given dose of hormone. Estrone, estriol, and other estrogens have different potencies relative to estradiol in different species of mammals. There are slight differences in the amino acid sequences of the insulins and vasopressins from different species and quite marked

differences in the chemical structure (Li and Papkoff, 1956) and physiologic activity (Knobil, Morse, Wolf and Greep, 1958) of the pituitary growth hormones of cattle and swine, on the one hand, and of primates, on the other.

#### A. ESTROGENS

The amount or activity of certain enzymes in the target organs of estrogens has been found to vary with the amount of estrogen present. Examples of this phenomenon are  $\beta$ -glucuronidase (Odell and Fishman, 1950), fibrinolysin (Page, Glendening and Parkinson, 1951), and alkaline glycerophosphatase (Jones, Wade, and Goldberg, 1953). Kochakian (1947) reported that the amount of arginase in the rat kidney increased after the injection of estrogens. Enzyme activity is increased by other hormones as well; for example, progesterone has been found to increase the activity of phosphorylase (Zondek and Hestrin, 1947) and of adenosine triphosphatase (Jones, Wade, and Goldberg, 1952).

In most experiments the amount of enzyme present has been inferred from its activity, measured chemically or histochemically under conditions in which the amount of enzyme is rate-limiting. This does not enable one to distinguish between an actual increase in the number of molecules of enzyme present in the cell and an increase in the activity of the enzyme molecules without change in their number. A few enzymes can be measured by some other property, such as absorption at a specific wavelength, by which the actual amount of enzyme can be estimated (see review by Knox, Auerbach, and Lin, 1956). Knox and Auerbach (1955) found that the activity of the enzyme tryptophan peroxidase-oxidase (TPO) of the liver was decreased in adrenalectomized animals and increased by the administration of cortisone. Knox had shown previously that the administration of the substrate of the enzyme, tryptophan, would lead to an increase in the activity of the enzyme which was maximal in 6 to 10 hours. Evidence that the increased activity of enzyme following the administration of cortisone represents the synthesis of new protein molecules is supplied by experi-



ments in which it was found that the increase in enzyme activity is inhibited by ethionine and this inhibition is reversed by methionine. The amino acid analogue ethionine is known to inhibit protein synthesis and this inhibition of protein synthesis is overcome by methionine.

The injection of estrogen into the immature or castrate rodent produces a striking uptake of water by the uterus followed by a marked increase in its dry weight (Astwood, 1938). Holden (1939) postulated that the imbibition of water results from vasodilatation and from changes in the permeability of the blood vessels of the uterus. There is clear evidence (Mueller, 1957) that the subsequent increase in dry weight is due to an increased rate of synthesis of proteins and nucleic acids. The sex hormones and other steroids could be pictured as reacting with the protein or lipoprotein membrane around the cell or around some subcellular structure like a surface-wetting agent and in this way inducing a change in the permeability of the membrane. This might then increase the rate of entry of substances and thus alter the rate of metabolism within the cell. This theory could hardly account for the many notable specific relationships between steroid structure and biologic activity. Spaziani and Szego (1958) postulated that estrogens induce the release of histamine in the uterus and the histamine then alters the permeability of the blood vessels and produces the imbibition of water secondarily.

The uterus of the ovariectomized rat is remarkably responsive to estrogens and has been widely used as a test system. After ovariectomy, the content of ribonucleic acid of the uterus decreases to a low level and then is rapidly restored after injection of estradiol (Telfer, 1953). A single injection of 5 to 10  $\mu\text{g}$ . of estradiol brings about (1) the hyperemia and water imbibition described previously; (2) an increased rate of over-all metabolism as reflected in increased utilization of oxygen (David, 1931; Khayyal and Scott, 1931; Kerly, 1937; MacLeod and Reynolds, 1938; Walaas, Walaas and Löken, 1952a; Roberts and Szego, 1953a); (3) an increased rate of glycolysis (Kerly, 1937; Carroll, 1942; Stuermer and Stein, 1952; Walaas, Walaas

and Löken, 1952b; Roberts and Szego, 1953a); (4) an increased rate of utilization of phosphorus (Grauer, Strickler, Wolken and Cutuly, 1950; Walaas and Walaas, 1950); and (5) tissue hypertrophy as reflected in increased dry weight (Astwood, 1938), increased content of ribonucleic acid and protein (Astwood, 1938; Telfer, 1953; Mueller, 1957), and finally, after about 72 hours, an increased content of desoxyribonucleic acid (Mueller, 1957).

An important series of experiments by Mueller and his colleagues revealed that estrogens injected *in vivo* affect the metabolism of the uterus which can be detected by subsequent incubation of the uterus *in vitro* with labeled substrate molecules. Mueller (1953) first showed that pretreatment with estradiol increases the rate of incorporation of glycine-2- $\text{C}^{14}$  into uterine protein. He then found that estrogen stimulation increases that rate of incorporation into protein of all other amino acids tested: alanine, serine, lysine, and tryptophan. The peak of stimulation occurred about 20 hours after the injection of estradiol. In further studies (Mueller and Herranen, 1956) it was found that estrogen increases the rate of incorporation of glycine-2- $\text{C}^{14}$  and formate-2- $\text{C}^{14}$  into protein, lipid, and the purine bases, adenine and guanine, of nucleic acids. A stimulation of cholesterol synthesis in the mouse uterus 20 hours after administration of estradiol was shown by Emmelot and Bos (1954).

In more detailed studies of the effects of estrogens on the metabolism of "one-carbon units" Herranen and Mueller (1956) found that the incorporation of serine-3- $\text{C}^{14}$  into adenine and guanine was stimulated by pretreatment with estradiol. The incorporation was greatly decreased when unlabeled formate was added to the reaction mixture to trap the one-carbon intermediate. In contrast, the incorporation of  $\text{C}^{14}\text{O}_2$  into uridine and thymine by the surviving uterine segment was not increased by pretreatment with estradiol *in vivo* (Mueller, 1957).

To delineate further the site of estrogen effect on one-carbon metabolism, Herranen and Mueller (1957) studied the effect of estrogen pretreatment on serine methylase, the enzyme which catalyzes the equilibrium

between serine and glycine plus an active one-carbon unit. They found that serine aldolase activity, measured in homogenates of rat uteri, increased 18 hours after treatment *in vivo* with estradiol. It seemed that the estrogen-induced increase in the activity of this enzyme might explain at least part of the increased rate of one-carbon metabolism following estrogen injection. They found, however, that incubation of uterine segments in tissue culture medium (Eagle, 1955) for 18 hours produced a marked increase in both the activity of serine aldolase and the incorporation of glycine-2- $C^{14}$  into protein. The addition of estradiol to Eagle's medium did not produce a greater increase than the control to which no estradiol was added. Uterine segments taken from rats pretreated with estradiol for 18 hours, with their glycine-incorporating system activated by hormonal stimulation, showed very little further stimulation on being incubated in Eagle's medium for 18 hours. With a shorter period of pretreatment with estradiol, greater stimulation occurred on subsequent incubation in tissue culture fluid. These experiments suggest that the hormone and the incubation in tissue culture medium are affecting the same process, one which has a limited capacity to respond. When comparable experiments were performed with other labeled amino acids as substrates, similar results were obtained.

Mueller's work gave evidence that a considerable number of enzyme systems in the uterus are accelerated by the administration of estradiol—not only the enzymes for the incorporation of serine, glycine, and formate into adenine and guanine, but also the enzymes involved in the synthesis of fatty acids and cholesterol and independent enzymes for the activation of amino acids by the formation of adenosine monophosphate (AMP) derivatives. The initial step in protein synthesis has been shown to be the activation of the carboxyl group of the amino acid with transfer of energy from ATP, the formation of AMP + amino acid, and the release of pyrophosphate (Hoagland, Keller and Zamecnik, 1956). This reversible step was studied with homogenates of uterine tissue,  $P^{32}$ -labeled pyrophosphate, and a variety of amino

acids (Mueller, Herranen and Jervell, 1958). Seven of the amino acids tested, leucine, tryptophan, valine, tyrosine, methionine, glycine, and isoleucine, stimulated the exchange of  $P^{32}$  between pyrophosphate and ATP. Pretreatment of the uteri by estradiol injected *in vivo* increased the activity of these three enzymes. The activating effect of mixtures of these amino acids was the sum of their individual effects, from which it was inferred that a specific enzyme is involved in the activation of each amino acid. Since estrogen stimulated the exchange reaction with each of these seven amino acids, Mueller concluded that the hormone must affect the amount of each of the amino acid-activating enzymes in the soluble fraction of the cell.

Mueller (1957) postulated that estrogens increase the rate of many enzyme systems both by activating preformed enzyme molecules and by increasing the rate of *de novo* synthesis of enzyme molecules, possibly by removing membranous barriers covering the templates for enzyme synthesis. To explain why estrogens affect these enzymes in the target organs, but not comparable enzymes in other tissues, one would have to assume that embryonic differentiation results in the formation of enzymes in different tissues which, although catalyzing the same reaction, have different properties such as their responsiveness to hormonal stimulation.

As an alternative hypothesis, estrogen might affect some reaction which provides a substance required for all of these enzyme reactions. The carboxyl group of amino acids must be activated by ATP before the amino acid can be incorporated into proteins; the synthesis of both purines and pyrimidines requires ATP for the activation of the carboxyl group of certain precursors and for several other steps; the synthesis of cholesterol requires ATP for the conversion of mevalonic acid to squalene; and the synthesis of fatty acids is also an energy-requiring process. Thus if estrogens acted in some way to increase the amount of biologically useful energy, in the form of ATP or of energy-rich thioesters such as acetyl coenzyme A, it would increase the rate of synthesis of all of these compo-

nents of the cell. This would occur, of course, only if the supply of ATP, rather than the amount of enzyme, substrate, or some other cofactor, were the rate-limiting factor in the synthetic processes.

When purified estrogens became available, they were tested for their effects on tissues *in vitro*. Estrogens added *in vitro* increased the utilization of oxygen by the rat uterus (Khayyal and Scott, 1931) and the rat pituitary (Victor and Andersen, 1937). The addition of estradiol-17 $\beta$  at a level of 1  $\mu$ g. per ml. of incubation medium increased the rate of utilization of oxygen and of pyruvic acid by slices of human endometrium and increased the rate at which labeled glucose and pyruvate were oxidized to C<sup>14</sup>O<sub>2</sub> (Hagerman and Vilee, 1952, 1953a, 1953b). In experiments with slices of human placenta similar results were obtained and it was found that estradiol increased the rate of conversion of both pyruvate-2-C<sup>14</sup> and acetate-1-C<sup>14</sup> to C<sup>14</sup>O<sub>2</sub> (Vilee and Hagerman, 1953). From this and other evidence it was inferred that the estrogen acted at some point in the oxidative pathway common to pyruvate and acetate, *i.e.*, in the tricarboxylic acid cycle.

Homogenates of placenta also respond to estradiol added *in vitro*. With citric acid as substrate, the utilization of citric acid and oxygen and the production of  $\alpha$ -ketoglutaric acid were increased 50 per cent by the addition of estradiol to a final concentration of 1  $\mu$ g. per ml. (Vilee and Hagerman, 1953). The homogenates were separated by differential ultracentrifugation into nuclear, mitochondrial, microsomal, and nonparticulate fractions. The estrogen-stimulable system was shown to be in the nonparticulate fraction, the material which is not sedimented by centrifugating at 57,000  $\times$  *g* for 60 minutes (Vilee, 1955). Experiments with citric, *cis*-aconitic, isocitric, oxalosuccinic, and  $\alpha$ -ketoglutaric acids as substrates and with fluorocitric and *trans*-aconitic acids as inhibitors localized the estrogen-sensitive system at the oxidation of isocitric to oxalosuccinic acid, which then undergoes spontaneous decarboxylation to  $\alpha$ -ketoglutaric acid (Vilee and Gordon, 1955). Further investigations using the enzymes of the nonparticulate fraction of the human placenta revealed that, in ad-

dition to isocitric acid as substrate, only DPN and a divalent cation such as Mg<sup>++</sup> or Mn<sup>++</sup> were required (Vilee, 1955; Gordon and Vilee, 1955; Vilee and Gordon, 1956). The estrogen-sensitive reaction was formulated as a DPN-linked isocitric dehydrogenase:

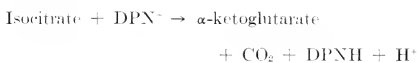

It was found that the effect of the hormone on the enzyme can be measured by the increased rate of disappearance of citric acid, the increased rate of appearance of  $\alpha$ -ketoglutaric acid, or by the increased rate of reduction of DPN, measured spectrophotometrically by the optical density at 340 m $\mu$ . As little as 0.001  $\mu$ g. estradiol per ml. ( $4 \times 10^{-9}$  M) produced a measurable increase in the rate of the reaction, and there was a graded response to increasing concentrations of estrogen. The dose-response curve is typically sigmoid. This system has been used to assay the estrogen content of extracts of urine (Gordon and Vilee, 1956) and of tissues (Hagerman, Wellington and Vilee, 1957; Loring and Vilee, 1957).

Attempts to isolate and purify the estrogen-sensitive enzyme were not very successful. By a combination of low temperature alcohol fractionation and elution from calcium phosphate gel a 20-fold purification was obtained (Hagerman and Vilee, 1957). However, as the enzyme was purified it was found that an additional cofactor was required. Either uridine triphosphate (UTP) or ATP added to the system greatly increased the magnitude of the estrogen effect and, subsequently, adenosine diphosphate (ADP) was recovered from the incubation medium and identified by paper chromatography (Vilee and Hagerman, 1957). Talalay and Williams-Ashman (1958) confirmed our observations and showed that the additional cofactor was triphosphopyridine nucleotide (TPN) which was required in minute amounts. This finding was confirmed by Vilee and Hagerman (1958) and the estrogen-sensitive enzyme system of the placenta is now believed to be a transhydrogenase which catalyzes the transfer of hydrogen ions and electrons

from TPNH to DPN:



The transhydrogenation system can be coupled to glucose 6-phosphate dehydrogenase as well as to isocitric dehydrogenase (Talalay and Williams-Ashman, 1958; Villee and Hagerman, 1958) and presumably can be coupled to any TPNH-generating system.

If the estrogen-stimulable transhydrogenation reaction were readily reversible, an enzyme such as lactic dehydrogenase which requires DPN should be stimulated by estrogen if supplied with substrate amounts of TPN, catalytic amounts of DPN, and a preparation from the placenta containing the transhydrogenase. Experiments to test this prediction were made using lactic dehydrogenase and alcohol dehydrogenase of both yeast and liver (Villee, 1958a). It was not possible to demonstrate an estrogen stimulation of either enzyme system in either the forward or the reverse direction. The stimulation of the lactic dehydrogenase-DPN oxidase system of the rat uterus by estrogens administered *in vivo* reported by Bever, Velardo and Hisaw (1956) might be explained by the stimulation of a transhydrogenase, but it has not yet been possible to demonstrate a coupling of this transhydrogenase and lactic dehydrogenase.

The stimulating effect of a number of steroids has been tested with a system in which the transhydrogenation reaction is coupled to isocitric dehydrogenase (Villee and Gordon, 1956; Hollander, Nolan and Hollander, 1958). Estrone, equilin, equilenin, and 6-ketoestradiol have activities essentially the same as that of estradiol-17 $\beta$ . Samples of 1-methyl estrone and 2-methoxy-estrone had one-half the activity of estradiol. Estriol is only weakly estrogenic in this system; 33  $\mu\text{g}$ . estriol are less active than 0.1  $\mu\text{g}$ . estradiol-17 $\beta$  (Villee, 1957a). The activities of estriol and 16-epiestriol are similar, whereas 16-oxoestradiol is more active than either, with about 10 per cent as much activity as estradiol-17 $\beta$ .

Certain analogues of stilbestrol have been shown to be anti-estrogens *in vivo*. When applied topically to the vagina of the rat, they prevent the cornification normally in-

duced by the administration of estrogen (Barany, Morsing, Muller, Stallberg, and Stenhagen, 1955). One of these, 1,3-di-*p*-hydroxyphenylpropane, was found to be strongly anti-estrogenic in the placental system *in vitro*: it prevented the acceleration of the transhydrogenase-isocitric dehydrogenase system normally produced by estradiol-17 $\beta$  (Villee and Hagerman, 1957). The inhibitory power declines as the length of the carbon chain connecting the two phenolic rings is increased and 1,10-di-*p*-hydroxyphenyldecane had no inhibitory action. Similar inhibitions of the estradiol-sensitive system were observed with stilbestrol, estradiol-17 $\alpha$ , and a smaller anti-estrogenic effect was found with estriol (Villee, 1957a). The inhibition induced by these compounds can be overcome by adding increased amounts of estradiol-17 $\beta$ . When stilbestrol is added alone at low concentration,  $10^{-7}$  M, it has a stimulatory effect equal to that of estradiol-17 $\beta$  (Glass, Loring, Spence and Villee, 1961).

The quantitative relations between the amounts of stimulator and inhibitor suggest that this inhibition is a competitive one. It was postulated that this phenomenon involves a competition between the steroids for specific binding sites on the estrogen-sensitive enzyme (Villee, 1957b; Hagerman and Villee, 1957). When added alone, estriol and stilbestrol are estrogenic and increase the rate of the estrogen-sensitive enzyme. In the presence of both estradiol and estriol, the total enzyme activity observed is the sum of that due to the enzyme combined with a potent activator, estradiol-17 $\beta$ , and that due to the enzyme combined with a weak activator, estriol. When the concentration of estriol is increased, some of the estradiol is displaced from the enzyme and the total activity of the enzyme system is decreased.

Two hypotheses have been proposed for the mechanism of action of estrogens on the enzyme system of the placenta. One states that the estrogen combines with an inactive form of the enzyme and converts it to an active form (Hagerman and Villee, 1957). When this theory was formulated the evidence indicated that the estrogen acted on a specific DPN-linked isocitric dehydrogenase. The theory is equally applicable if the

estrogen-sensitive enzyme is a transhydrogenase, as the evidence now indicates. The results of kinetic studies with the coupled isocitric dehydrogenase-transhydrogenase system are consistent with this theory (Gordon and Vilee, 1955; Vilee, 1957b; Hagerman and Vilee, 1957). Apparent binding constants for the enzyme-hormone complex (Gordon and Vilee, 1955) and for enzyme-inhibitor complexes have been calculated (Hagerman and Vilee, 1957).

The observation that estradiol and estrone, which differ in structure only by a pair of hydrogen atoms, are equally effective in stimulating the reaction suggested that the steroid might be acting in some way as a hydrogen carrier from substrate to pyridine nucleotide (Gordon and Vilee, 1956). Talalay and Williams-Ashman (1958) suggested that the estrogens act as coenzymes in the transhydrogenation reaction and postulated that the reactions were:

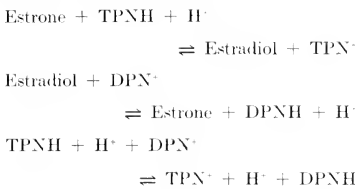

This formulation implies that the estrogen-sensitive transhydrogenation reaction is catalyzed by the estradiol-17 $\beta$  dehydrogenase characterized by Langer and Engel (1956). This enzyme was shown by Langer (1957) to use either DPN or TPN as hydrogen acceptor but it reacts more rapidly with DPN. Ryan and Engel (1953) showed that this enzyme is present in rat liver, and in human adrenal, ileum, and liver. However, no estrogen-stimulable enzyme is demonstrable in rat or human liver (Vilee, 1955). The nonparticulate fraction obtained by high speed centrifugation of homogenized rabbit liver rapidly converts estradiol to estrone if DPN is present as hydrogen acceptor, but does not contain any estrogen-stimulable transhydrogenation system.

It will not be possible to choose between these two hypotheses until either the estrogen-sensitive transhydrogenase and the estradiol dehydrogenase have been separated or there is conclusive proof of their

identity. Talalay, Williams-Ashman and Hurllock (1958) reported a 100-fold purification of the dehydrogenase without separation of the transhydrogenase activity and found that both activities were inhibited identically by sulfhydryl inhibitors. In contrast, Hagerman and Vilee (1958) obtained partial separation of the two activities by the usual techniques of protein fractionation, and reported that a 50 per cent inhibition of transhydrogenase is obtained with *p*-chloromercurisulfonic acid at a concentration of  $10^{-5}$  M whereas  $10^{-4}$  M *p*-chloromercurisulfonic acid is required for a 50 per cent inhibition of the dehydrogenase. The evidence that these two activities are mediated by separate and distinct proteins has been summarized by Vilee, Hagerman and Joel (1960).

The transhydrogenase present in the mitochondrial membranes of heart muscle was shown by Ball and Cooper (1957) to be inhibited by  $4 \times 10^{-5}$  M thyroxine. The estrogen-sensitive transhydrogenase of the placenta is also inhibited by thyroxine (Vilee, 1958b). The degree of inhibition is a function of the concentration of the thyroxine and the inhibition can be overcome by increased amounts of estrogen. Suitable control experiments show that thyroxine at this concentration does not inhibit the glucose 6-phosphate dehydrogenase or isocitric dehydrogenase used as TPNH-generating systems to couple with the transhydrogenase. Triiodothyronine also inhibits the estrogen-sensitive transhydrogenase but tyrosine, diiodotyrosine and thyronine do not. The thyroxine does not seem to be inhibiting by binding the divalent cation,  $\text{Mn}^{++}$  or  $\text{Mg}^{++}$ , required for activity, for the inhibition is not overcome by increasing the concentration of the cation 10-fold.

In the intact animal estrogens stimulate the growth of the tissues of certain target organs. The estrogen-sensitive enzyme has been shown to be present in many of the target organs of estrogens: in human endometrium, myometrium, placenta, mammary gland, and mammary carcinoma, in rat ventral prostate gland and uterus, and in mammothrophic-dependent transplantable tumors of the rat and mouse pituitary. In contrast, it is not demonstrable in comparable preparations from liver, heart, lung, brain, or

kidney. The growth of any tissue involves the utilization of energy, derived in large part from the oxidation of substrates, for the synthesis of new chemical bonds and for the reduction of substances involved in the synthesis of compounds such as fatty acids, cholesterol, purines, and pyrimidines.

The physiologic responses to estrogen action, such as water imbibition and protein and nucleic acid synthesis, are processes not directly dependent on the activity of transhydrogenase. However, all of these processes are endergonic, and one way of increasing their rate would be to increase the supply of biologically available energy by speeding up the Krebs tricarboxylic acid cycle and the flow of electrons through the electron transmitter system. Much of the oxidation of substrates by the cell produces TPNH, whereas the major fraction of the biologically useful energy of the cell comes from the oxidation of DPNH in the electron transmitter system of the cytochromes. Hormonal control of the rate of transfer of hydrogens from TPN to DPN could, at least in theory, influence the over-all rate of metabolism in the cell and secondarily influence the amount of energy available for synthetic processes. Direct evidence of this was shown in our early experiments in which the oxygen consumption of tissue slices of target organs was increased by the addition of estradiol (Hagerman and Villee, 1952; Villee and Hagerman, 1953).

This theory assumes that the supply of energy is rate-limiting for synthetic processes in these target tissues and that the activation of the estrogen-sensitive enzyme does produce a significant increase in the supply of energy. The addition of estradiol *in vitro* produces a significant increase in the total amount of isocitric acid dehydrogenated by the placenta (Villee, Loring and Sarnet, 1958). Slices of endometrium to which no estradiol was added *in vitro* utilized oxygen and metabolized substrates to carbon dioxide at rates which paralleled the levels of estradiol in the blood and urine of the patient from whom the endometrium was obtained (Hagerman and Villee, 1953b). Estradiol increases the rate of synthesis of ATP by homogenates of human

placenta (Villee, Joel, Loring and Spencer, 1960).

The reductive steps in the biosynthesis of steroids, fatty acids, purines, serine, and other substances generally require TPNH rather than DPNH as hydrogen donor. The cell ordinarily contains most of its TPN in the reduced state and most its DPN in the oxidized state (Glock and McLean, 1955). If the amount of TPN<sup>+</sup> is rate-limiting, a transhydrogenase, by oxidizing TPN and reducing DPN, would permit further oxidation of substrates such as isocitric acid and glucose 6-phosphate, which require TPN<sup>+</sup> as hydrogen acceptor and which are key reactions in the Krebs tricarboxylic acid cycle and the hexose monophosphate shunt, respectively. Furthermore, the experiments of Kaplan, Schwartz, Frech and Ciotti (1956) indicate that less biologically useful energy, as ATP, is obtained when TPNH is oxidized by TPNH cytochrome *c* reductase than when DPNH is oxidized by DPNH cytochrome *c* reductase. Thus, a transhydrogenase, by transferring hydrogens from TPNH to DPN before oxidation in the cytochrome system, could increase the energy yield from a given amount of TPNH produced by isocitrate or glucose 6-phosphate oxidation. The increased amount of biologically useful energy could be used for growth, for protein and nucleic acid synthesis, for the imbibition of water, and for the other physiologic effects of estrogens.

Estrogen stimulation of the transhydrogenation reaction would tend to decrease rather than increase the amount of TPNH in the cell. Thus the estrogen-induced stimulation of the synthesis of steroids, fatty acids, proteins, and purines in the uterus can be explained more reasonably as due to an increased supply of energy rather than to an increased supply of TPNH.

The theory that estrogens stimulate transhydrogenation by acting as coenzymes which are rapidly and reversibly oxidized and reduced does not explain the pronounced estrogenic activity *in vivo* of stilbestrol, 17 $\alpha$ -ethinyl estradiol, or bisdehydroisynolic acid, for these substances do not contain groups that could be readily oxidized or reduced. The exact mechanism

of action of estrogens at the biochemical level remains to be elucidated, but the data available permit the formulation of a detailed working hypothesis. The notable effects of estrogens and androgens on behavior (see chapter by Young) are presumably due to some direct or indirect effect of the hormone on the central nervous system. The explanation of these phenomena in physiologic and biochemical terms remains for future investigations to provide.

#### B. ANDROGENS

Although there is a considerable body of literature regarding the responses at the biologic level to administered androgens and progesterone, much less is known about the site and mechanism of action of these hormones than is known about the estrogens. The review by Roberts and Szego (1953b) deals especially with the synergistic and antagonistic interactions of the several steroidal sex hormones.

The rapid growth of the capon comb following the administration of testosterone has been shown to involve a pronounced increase in the amount of mucopolysaccharide present, as measured by the content of glucosamine (Ludwig and Boas, 1950; Schiller, Benditt and Dorfman, 1952). It is not known whether the androgen acts by increasing the amount or activity of one of the enzymes involved in the synthesis of polysaccharides or whether it increases the amount or availability of some requisite cofactor. Many of the other biologic effects of androgens do not seem to involve mucopolysaccharide synthesis and the relation of these observations to the other roles of androgens remains to be determined.

Mann and Parsons (1947) found that castration of rabbits resulted in a decreased concentration of fructose in the semen. Within 2 to 3 weeks after castration the amount of fructose in the semen dropped to zero, but rapidly returned to normal following the subcutaneous implantation of a pellet of testosterone. Fructose reappeared in the semen of the castrate rat 10 hours after the injection of 10 mg. of testosterone (Rudolph and Samuels, 1949). The coagulating gland of the rat, even when trans-

planted to a new site in the body, also responds by producing fructose when the host is injected with testosterone. The amount of citric acid and ergothioneine in the semen is also decreased by castration and increased by the implantation of testosterone pellets (Mann, 1955). The experiments of Hers (1956) demonstrate that fructose is produced in the seminal vesicle by the reduction of glucose to sorbitol and the subsequent oxidation of sorbitol to fructose. The reduction of glucose requires TPNH as hydrogen donor and the oxidation of sorbitol requires DPX as hydrogen acceptor. The sum of these two reactions provides for the transfer of hydrogens from TPNH to DPX. If androgens act as cofactors which are reversibly oxidized and reduced, and thus transfer hydrogens from TPNH to DPX as postulated by Talalay and Williams-Ashman (1958), one would expect that an increased amount of androgen, by providing a competing system for hydrogen transfer, would decrease rather than increase the production of fructose. The marked increases in the citric acid and ergothioneine content of semen are not readily explained by this postulated site of action of androgens.

An increase in the activity of  $\beta$ -glucuronidase in the kidney has been reported following the administration of androgens (Fishman, 1951). This might be interpreted as an adaptive increase in enzyme induced by the increased concentration of substrate, or by a direct effect of the steroid on the synthesis of the enzyme.

The respiration of slices of prostate gland of the dog is decreased by castration or by the administration of stilbestrol (Barron and Huggins, 1944). The decrease in respiration occurs with either glucose or pyruvate as substrate. The seminal vesicle of the rat responds similarly to castration. Rudolph and Samuels (1949) found that respiration of slices of seminal vesicle is decreased by castration and restored to normal values within 10 hours after the injection of testosterone. Experiments by Dr. Phillip Corfman in our laboratory with slices of prostate gland from patients with benign prostatic hypertrophy showed that oxygen utilization was reduced 50 per cent by estradiol added

*in vitro* at a level of 1  $\mu$ g. per ml. Respiration of slices of the ventral prostate gland of the rat is decreased by castration and increased by administered testosterone (Nylen and Williams-Ashman, 1953). These workers showed that lipogenesis from acetate-1-C<sup>14</sup> in the prostate is also significantly diminished by castration and restored to normal by administered testosterone.

The succinic dehydrogenase of the liver has been found to be increased by castration and decreased by the administration of testosterone (Kalman, 1952; Rindani, 1958), the enzyme is also inhibited by testosterone added *in vitro* (Kalman, 1952). In contrast, Davis, Meyer and McShan (1949) found that the succinic dehydrogenase of the prostate and seminal vesicles is decreased by castration and increased by the administration of testosterone.

An interesting example of an androgen effect on a specific target organ is the decreased size of the levator ani and other perineal muscles of the rat following castration. The administration of androgen stimulates the growth of these muscles and increases their glycogen content (Leonard, 1952). However, their succinoxidase activity is unaffected by castration or by the administration of testosterone. Courier and Marois (1952) reported that the growth of these muscles stimulated by androgen is inhibited by cortisone. The remarkable responsiveness of these muscles to androgens *in vivo* gave promise that slices or homogenates of this tissue incubated with androgens might yield clues as to the mode of action of the male sex hormones. Homogenates of perineal and masseter muscles of the rat responded to androgens administered *in vivo* with increased oxygen consumption and ATP production (Loring, Spencer and Villee, 1961). The experiments suggested that the activity of DPNH-cytochrome *c* reductase in these tissues is controlled by androgens.

### C. PROGESTERONE

Attempts to clarify the biochemical basis of the role of progesterone have been hampered by the requirement, in most instances, for a previous stimulation of the tissue by estrogen. The work of Wade and Jones

(1956a, b) demonstrated an interesting effect of progesterone added *in vitro* on several aspects of metabolism in rat liver mitochondria. Progesterone, but not estradiol, testosterone, 17 $\alpha$ -hydroxyprogesterone, or any of several other steroids tested, stimulated the adenosine triphosphatase activity of rat liver mitochondria. This stimulation is not the result of an increased permeability of the mitochondrial membrane induced by progesterone, for the stimulatory effect is also demonstrable with mitochondria that have been repeatedly frozen and thawed to break the membranes. Other experiments showed that ATP was the only substrate effective in this system; progesterone did not activate the release of inorganic phosphate from AMP, ADP, or glycerophosphate.

In other experiments with rat liver mitochondria (Wade and Jones, 1956b), progesterone at a higher concentration ( $6 \times 10^{-4}$  M) was found to inhibit the utilization of oxygen with one of the tricarboxylic acids or with DPNH as substrate. This inhibition is less specific and occurred with estradiol, testosterone, pregnanediol, and 17 $\alpha$ -hydroxyprogesterone, as well as with progesterone. The inhibition of respiration by high concentrations of steroids *in vitro* has been reported many times and with several different tissues; it seems to be relatively unspecific. Wade and Jones were able to show that progesterone inhibits the reduction of cytochrome *c* but accelerates the oxidation of ascorbic acid. They concluded that progesterone may perhaps uncouple oxidation from phosphorylation in a manner similar to that postulated for dinitrophenol. The site of action of this uncoupling appears to be in the oxidation-reduction path between DPNH and cytochrome *c*. Mueller (1953) found that progesterone added *in vitro* decreases the incorporation of glycine-2-C<sup>14</sup> into the protein of strips of rat uterus, thus counteracting the stimulatory effect of estradiol administered *in vivo*.

Zander (1958) reported that  $\Delta$ 4-3-ketopregnen-20- $\alpha$ -ol and  $\Delta$ 4-3-ketopregnen-20- $\beta$ -ol are effective gestational hormones in the mouse, rabbit, and man, although somewhat less active in general than is progesterone. An enzyme in rat ovary which converts progesterone to pregnen-20- $\alpha$ -ol, and also catalyzes the reverse reaction, was



described by Wiest (1956). The conversion occurred when slices of ovary were incubated with DPN. Wiest postulated that the progesterone-pregnene-20- $\alpha$ -ol system might play a role in hydrogen transfer, in a manner analogous to that postulated by Talalay and Williams-Ashman (1958) for estrone-estradiol-17 $\beta$ , but his subsequent experiments ruled out this possibility, for he was unable to demonstrate any progesterone-stimulable transhydrogenation reaction.

The nature of the effect of progesterone and of estrogens on myometrium has been investigated extensively by Csapo. Csapo and Corner (1952, 1953) found that ovariectomy decreased the maximal tension of the myometrium and decreased its content of actomyosin. The administration of estradiol to the ovariectomized rabbit over a period of 7 days restored both the actomyosin content and the maximal tension of the myometrium to normal. The concentration of ATP and of creatine phosphate in the myometrium is decreased by ovariectomy but is restored by only 2 days of estrogen treatment. This suggests that the effect on intermediary metabolism occurs before the effect on protein (*i.e.*, actomyosin) synthesis. Csapo (1956a) concluded that estrogen is a limiting substance in the synthesis of the contractile proteins of myometrium, but he could not differentiate between an effect of estrogen on some particular biosynthetic reaction and an effect of estrogen on some fundamental reaction which favors synthesis in general. He was unable to demonstrate any comparable effect of progesterone on the contractile actomyosin-ATP system of the myometrium.

Other observations provide an explanation for the well known effect of progesterone in decreasing the contractile activity of myometrium, not by any effect on the contractile system itself, but in some previous step in the excitation process. Under the domination of progesterone the myometrial cells have a decreased intracellular concentration of potassium ions and an increased concentration of sodium ions (Horvath, 1954). The change in ionic gradient across the cell membrane is believed to be responsible for the altered resting potential and the partial depolarization of the cell mem-

brane which results in decreased conductivity and decreased pharmacologic reactivity of the myometrial cell. The means by which progesterone produces the changes in ionic gradients is as yet unknown. Csapo postulates that the hormone might decrease the rate of metabolism which in turn would lessen the rate of the "sodium pump" of the cell membrane. The contractile elements, the actomyosin-ATP system, are capable of full contraction but, because of the partial block in the mechanism of excitation and of propagation of impulses (Csapo, 1956b), the muscle cells cannot operate effectively; the contractile activity remains localized. Csapo (1956a) showed that the progesterone block is quickly reversible and disappears if progesterone is withdrawn for 24 hours. He concluded that the progesterone block is necessary for the continuation of pregnancy and that its withdrawal is responsible for the onset of labor.

Most investigators who have speculated about the mode of action of steroids—whether they believe the effect is by activating an enzyme, by altering the permeability of a membrane, or by serving as a coenzyme in a given reaction—have emphasized the physical binding of the steroid to a protein as an essential part of the mechanism of action or a preliminary step to that action. They have in this way explained the specificities, synergisms, and antagonisms of the several steroids in terms of the formation of specific steroid-protein complexes. The differences between different target organs, *e.g.*, those that respond to androgens and those that respond to estrogens, can be attributed to differences in the distribution of the specific proteins involved in these binding reactions. Viewed in this light, the problem of the mode of action of sex hormones becomes one aspect of the larger problem of the biochemical basis of embryonic differentiation of tissues.

#### IV. References

- ALLEN, W. M. 1939. Biochemistry of the corpus luteum hormone, progesterone. In *Sex and Internal Secretions*, 2nd ed., E. Allen, C. H. Danforth and E. A. Doisy, Eds., pp. 901-928. Baltimore: The Williams & Wilkins Company.
- ASTWOOD, E. B. 1938. A six-hour assay for the quantitative determination of estrone. *Endocrinology*, **23**, 25-31.
- BAGGETT, B., ENGEL, L. L., SAVARD, K., and DOREMAN,

- R. I. 1956. The conversion of testosterone- $3C^{14}$  to  $17\beta$ -estradiol- $17\beta$  by human ovarian tissue. *J. Biol. Chem.*, **221**, 931-941.
- BALE, G. G., AND COOPER, O. 1957. Oxidation of reduced triphosphopyridine nucleotide as mediated by the transhydrogenase reaction and its inhibition by thyroxine. *Proc. Nat. Acad. Sci.*, **43**, 357-364.
- BARANY, E., MORSENG, P., MULLER, W., STALLBERG, G., AND STENHAGEN, E. 1955. Inhibition of estrogen-induced proliferation of the vaginal epithelium of the rat by topical application of certain 4, 4'-hydroxy-diphenyl-alkanes and related compounds. *Acta Soc. Med. Uppsala*, **60**, 68-74.
- BARRON, E. S. G., AND HUGGINS, C. 1944. The metabolism of isolated prostatic tissue. *J. Urol.*, **51**, 630-634.
- BEVER, A. T., VELABDO, J. T., AND HISAW, F. L. 1956. Action of estrogens on lactic dehydrogenase-DPNH oxidase system of rat uterus. *Endocrinology*, **58**, 512-522.
- BLOCH, K. 1951. II. Use of isotopes in hormone problems: the biologic synthesis of cholesterol. *Recent Progr. Hormone Res.*, **6**, 111-129.
- BONGIOVANNI, A. M. 1953. The detection of pregnanediol and pregnanetriol in the urine of patients with adrenal hyperplasia. Suppression with cortisone. *Bull. John Hopkins Hosp.*, **92**, 244-251.
- CARROLL, W. R. 1942. Influence of estrogen on respiration of rat uterine tissue. *Proc. Soc. Exper. Biol. & Med.*, **49**, 50-52.
- CASPI, E., ROSENFELD, G., AND DORFMAN, R. T. 1956. Degradation of cortisol- $C^{14}$  and corticosterone- $C^{14}$  biosynthesized from acetate- $1C^{14}$ . *J. Organ. Chem.*, **21**, 814-815.
- CLAYTON, R. B., AND BLOCH, K. 1956. The biologic conversion of lanosterol to cholesterol. *J. Biol. Chem.*, **218**, 319-325.
- COLOWICK, S. P., CORI, G. T., AND SLEIN, M. W. 1947. The effect of adrenal cortex and anterior pituitary extracts and insulin on the hexokinase reaction. *J. Biol. Chem.*, **168**, 583-596.
- COURRIER, R., AND MAROIS, M. 1952. Endocrinologic relations entre la testostérone et le cortisone dans leur effets sur certains organes récepteurs. *Compt. rend. Acad. Sci.*, **234**, 271-273.
- CASPO, A. 1956a. Progesterone block. *Am. J. Anat.*, **98**, 273.
- CASPO, A. 1956b. The mechanism of effect of the ovarian steroids. *Recent Progr. Hormone Res.*, **12**, 105-131.
- CASPO, A., AND CORNER, G. W. 1952. The antagonistic effects of estrogen and progesterone on the striate phenomenon in uterine muscle. *Endocrinology*, **51**, 378-385.
- CASPO, A., AND CORNER, G. W. 1953. The effect of estrogen on the isometric tension of rabbit uterine strips. *Science*, **117**, 162-164.
- DAUGHADAY, W. H. 1956. Evidence for two corticosteroid binding systems in human plasma. *J. Lab. & Clin. Med.*, **18**, 799-800.
- DAVID, J. C. 1931. The action of estrin on the oxygen consumption of the uteri of mice. *J. Pharmacol. & Exper. Therap.*, **43**, 1-11.
- DAVIS, J. S., MEYER, R. C., AND McSHAN, W. H. 1949. Effect of androgen and estrogen on succinic dehydrogenase and cytochrome oxidase of rat prostate and seminal vesicle. *Endocrinology*, **44**, 1-7.
- DOISY, E. A. 1939. Biochemistry of estrogenic compounds. In *Sex and Internal Secretions*, 2nd ed., E. Allen, C. H. Danforth and E. A. Doisy, Eds., pp. 846-876. Baltimore: The Williams & Wilkins Company.
- DOISY, E. A., VELER, C. D., AND THAYER, S. A. 1929. Folliculin from urine of pregnant women. *Am. J. Physiol.*, **90**, 329-330.
- EAGLE, H. 1955. The specific amino acid requirements of a human carcinoma cell (strain HeLa) in tissue culture. *J. Exper. Med.*, **102**, 37-48.
- EDINOFF, M. L., KNOLL, J. E., MARANO, B. J., KYAMIE, E., ROSENFELD, R. S., AND HELLMAN, L. 1958. Cholesterol biosynthesis: studies related to the metabolic role of squalene. *J. Clin. Invest.*, **37**, 655-659.
- EMMELOT, P., AND BOS, L. 1954. The influence of estrogens on the protein and lipid metabolism of the mouse uterus studied with acetate- $1C^{14}$ . *Rec. Trav. Chim.*, **73**, 874-877.
- FISHMAN, W. H. 1951. Relationship between estrogens and enzyme activity. *Vitamins & Hormones*, **9**, 213-236.
- GLASS, R. B., LORING, J. M., SPENCER, J. M., AND VILLEE, C. A. 1961. The estrogenic properties *in vitro* of diethylstilbestrol and substances related to estradiol. *Endocrinology*, **68**, 327-333.
- GLOCK, G. E., AND McLEAN, P. 1955. Levels of oxidized and reduced diphosphopyridine and triphosphopyridine nucleotide in animal tissues. *Biochem. J.*, **61**, 388-390.
- GORDON, E. E., AND VILLEE, C. A. 1955. Spectrophotometric studies of the stimulation of human placental preparations by estradiol. *J. Biol. Chem.*, **216**, 215-224.
- GORDON, E. E., AND VILLEE, C. A. 1956. An *in vitro* assay for estradiol- $17\beta$  and estrone. *Endocrinology*, **58**, 150-157.
- GRATER, R. C., STRICKLER, H. S., WOLKEN, J. J., AND CUTCULY, E. 1950. Influence of estradiol on  $P^{32}$  uptake by the uterus. *Proc. Soc. Exper. Biol. & Med.*, **75**, 651-654.
- HAGERMAN, D. D., AND VILLEE, C. A. 1952. Effects of estradiol on the metabolism of human endometrium *in vitro*. *Arch. Biochem.*, **40**, 481-483.
- HAGERMAN, D. D., AND VILLEE, C. A. 1953a. Effects of estradiol on the metabolism of human endometrium *in vitro*. *J. Biol. Chem.*, **203**, 425-431.
- HAGERMAN, D. D., AND VILLEE, C. A. 1953b. Effects of the menstrual cycle on the metabolism of human endometrium. *Endocrinology*, **53**, 667-673.
- HAGERMAN, D. D., AND VILLEE, C. A. 1957. Estro-

- gen sensitive isocitric dehydrogenase. *J. Biol. Chem.*, **229**, 589-597.
- HAGERMAN, D. D., AND VILLEE, C. A. 1958. Metabolic studies of the mechanism of action of estrogens. In *Symposium on the Endocrinology of Pregnancy*, Charles Lloyd, Ed., pp. 317-328. New York: Academic Press, Inc.
- HAGERMAN, D. D., WELLINGTON, F. M., AND VILLEE, C. A. 1957. Estrogens in marine invertebrates. *Biol. Bull.*, **112**, 180-183.
- HAYANO, M., AND DORFMAN, R. I. 1953. The enzymatic C-11 $\beta$ -hydroxylation of steroids. *J. Biol. Chem.*, **201**, 175-188.
- HAYANO, M., LINDBERG, M. C., DORFMAN, R. I., HANCOCK, J. E. H., AND DOERING, W. VON E. 1955. On the mechanism of the C-11 $\beta$ -hydroxylation of steroids; a study with H<sub>2</sub>O<sup>18</sup> and O<sub>2</sub><sup>18</sup>. *Arch. Biochem.*, **59**, 529-532.
- HAYNES, R. C., SUTHERLAND, E. W., AND RALL, T. W. 1960. The role of cyclic adenylic acid in hormone action. *Recent Progr. Hormone Res.*, **16**, 121-132.
- HENION, W. F., AND SUTHERLAND, E. W. 1957. Immunologic differences of phosphorylases. *J. Biol. Chem.*, **224**, 477-488.
- HERRANEN, A., AND MUELLER, G. C. 1956. Effect of estradiol on the metabolism of serine-C<sup>14</sup> in surviving uterine segments. *J. Biol. Chem.*, **223**, 369-375.
- HERRANEN, A. M., AND MUELLER, G. C. 1957. The effect of estradiol pretreatment on the serine aldolase activity of rat uteri. *Biochim. et Biophys. Acta*, **24**, 223-224.
- HERS, H. G. 1956. La m $\acute{e}$ canisme de la transformation de glucose on fructose par les v $\acute{e}$ sicles s $\acute{e}$ minales. *Biochim. et Biophys. Acta*, **22**, 202-203.
- HOAGLAND, M. B., KELLER, E. B., AND ZAMECNIK, P. C. 1956. Enzymatic carboxyl activation of amino acids. *J. Biol. Chem.*, **218**, 345-358.
- HOLDEN, R. B. 1939. Vascular reactions of the uterus of the immature rat. *Endocrinology*, **25**, 539-596.
- HOLLANDER, V. P., NOLAN, H. M., AND HOLLANDER, N. 1958. The structural specificity of the estrogen-sensitive enzyme system in placental homogenates. *J. Biol. Chem.*, **233**, 580-582.
- HORVATH, B. 1954. Ovarian hormones and the ionic balance of uterine muscle. *Proc. Nat. Acad. Sc.*, **40**, 515-521.
- JAILER, J. W. 1953. *Virilism*. Bull. New York Acad. Med., **29**, 377-394.
- JONES, H. W., JR., WADE, R., AND GOLDBERG, B. 1952. Phosphate liberation by endometrium in the presence of adenosine triphosphate. *Am. J. Obst. & Gynec.*, **64**, 1118-1124.
- JONES, H. W., JR., WADE, R., AND GOLDBERG, B. 1953. The uterus: biochemical and histochemical alkaline glycerophosphatase in normal endometrium, endometrial hyperplasia and adenocarcinoma. *Obst. & Gynec. Surv.*, **8**, 398-400.
- KALMAN, S. M. 1952. The effect of androgens on the succinoxide system of rat liver. *Endocrinology*, **50**, 361-365.
- KAPLAN, N. O., CIOTTI, M. M., HAMOLSKY, M., AND BIEBER, R. E. 1960. Molecular heterogeneity and evolution of enzymes. *Science*, **131**, 392-397.
- KAPLAN, N., SCHWARTZ, M., FRECH, M., AND CIOTTI, M. 1956. Phosphorylative and nonphosphorylative pathways of electron transfer in rat liver mitochondria. *Proc. Nat. Acad. Sc.*, **42**, 481-487.
- KEBLY, M. 1937. The effect of the estrous cycle on the metabolism of isolated rat uterus. *Biochem. J.*, **31**, 1544-1552.
- KHAYYAL, M. A., AND SCOTT, C. M. 1931. The oxygen consumption of the isolated uterus of the rat and mouse. *J. Physiol.*, **72**, 13P-14P.
- KIPNIS, D. M., AND CORI, C. F. 1957. Studies of tissue permeability. III. The effect of insulin on pentose uptake by the diaphragm. *J. Biol. Chem.*, **224**, 681-693.
- KNOBIL, E., MORSE, A., WOLF, R. C., AND GREEP, R. O. 1958. The action of bovine, porcine, and simian growth hormone preparations on the costochondral junction in the hypophysectomized rhesus monkey. *Endocrinology*, **62**, 348-354.
- KNOX, W. E., AND AUERBACH, V. H. 1955. The hormonal control of tryptophan peroxidase in the rat. *J. Biol. Chem.*, **214**, 307-313.
- KNOX, W. E., AUERBACH, V. H., AND LIN, E. C. C. 1956. Enzymatic and metabolic adaptations in animals. *Physiol. Rev.*, **36**, 164-254.
- KOCH, F. C. 1939. *Biochemistry of androgens*. In *Sex and Internal Secretions*, 2nd ed., E. Allen, C. H. Danforth and E. A. Doisy, Eds., pp. 807-845. Baltimore: The Williams & Wilkins Company.
- KOCHAKIAN, C. D. 1947. Effects of estrogens on the body and organ weights and the arginase and "alkaline" and "acid" phosphatases of the liver and kidney of castrated male mice. *Am. J. Physiol.*, **151**, 126-129.
- KRAHL, M. E., AND BORNSTEIN, J. 1954. Inhibition of glucose use in muscle extracts by lipoproteins. *Nature*, London, **173**, 949-950.
- LANGDON, R. G., AND BLOCH, K. 1953. The biosynthesis of squalene. *J. Biol. Chem.*, **200**, 129-134.
- LANGER, L. 1957. Preparation and properties of estradiol-17 $\beta$  dehydrogenase. Thesis, Radcliffe College.
- LANGER, L., AND ENGEL, L. L. 1956. Human placental estradiol-17 $\beta$  dehydrogenase. *Fed. Proc.*, **15**, 296; *J. Biol. Chem.*, **233**, 583-588.
- LEONARD, S. L. 1952. A glycostatic effect of testosterone on the perineal muscles of the rat. *Endocrinology*, **50**, 199-205.
- LEVENDAL, B. H., AND BERNSTEIN, H. 1954. Testosterone binding by modified bovine serum albumin. *Arch. Biochem.*, **52**, 353-357.
- LEVINE, R., AND GOLDSTEIN, M. S. 1955. On the mechanism of action of insulin. *Recent Progr. Hormone Res.*, **11**, 343-380.
- LI, C. H., AND PAPKOFF, H. 1956. Preparation and properties of growth hormone from *Lepus*

- and monkey pituitary glands. *Science*, **124**, 1203-1204.
- LORING, J. M., SPENCER, J. M., AND VILLEE, C. A. 1951. Some effects of androgens on intermediary metabolism in muscle. *Endocrinology*, **63**, 501-506.
- LORING, J. M., AND VILLEE, C. A. 1957. The estrogen content of human placentas. *Acta endocrinol.*, **25**, 371-376.
- LUDWIG, A. W., AND BOAS, N. F. 1950. The effects of testosterone on the connective tissue of the comb of the cockerel. *Endocrinology*, **46**, 291-298.
- MACLEOD, J., AND REYNOLDS, S. R. M. 1938. Vascular, metabolic, and motility responses of uterine tissue following administration of estrin. *Proc. Soc. Exper. Biol. & Med.*, **37**, 666-668.
- MANX, T. 1955. Male sex hormone and its role in reproduction. *Recent Progr. Hormone Res.*, **12**, 353-376.
- MANX, T., AND PARSONS, U. 1947. Effect of testicular hormone on the formation of seminal fructose. *Nature*, London, **160**, 294.
- MARRIAN, G. F., AND BAULD, W. S. 1955. The isolation of 16-epioestradiol from the urine of pregnant women. *Biochem. J.*, **59**, 136-141.
- MEYER, A. S. 1955. 19-Hydroxylation of  $\Delta^4$ -androstene-3,17-dione and dehydroepiandrosterone by bovine adrenals. *Experientia*, **11**, 99-102.
- MUELLER, G. C. 1953. Incorporation of glycine- $2\text{-C}^{14}$  into protein by surviving uteri from estradiol-treated rats. *J. Biol. Chem.*, **204**, 77-90.
- MUELLER, G. C. 1957. A discussion of the mechanism of action of steroid hormones. *Cancer Res.*, **17**, 490-506.
- MUELLER, G. C., AND HERRANEN, A. 1956. Metabolism of 1-carbon fragments by surviving uteri from estradiol-treated rats. *J. Biol. Chem.*, **219**, 585-594.
- MUELLER, G. C., HERRANEN, A. M., AND JERVELL, K. F. 1958. Studies on the mechanism of action of estrogens. *Recent Progr. Hormone Res.*, **14**, 95-139.
- NATHANSON, I. T., ENGEL, L. L., AND KELLEY, R. M. 1951. Effect of ACTH on urinary excretion of steroids in neoplastic disease. In *Proceedings of the Second ACTH Conference*, J. R. Mote, Ed., Vol. 1, p. 51.
- NYDEN, S. J., AND WILLIAMS-ASHMAN, H. G. 1953. Influence of androgens on synthetic reactions in ventral prostate tissue. *Am. J. Physiol.*, **172**, 588-600.
- OBELI, L. D., AND FISHMAN, W. H. 1950. Studies on  $\beta$ -glucuronidase. I. Activities in human endometrium. *Am. J. Obst. & Gynec.*, **59**, 200-203.
- PAGE, E. W., GLENBENING, M. B., AND PARKINSON, P. 1951. Cyclic biochemical changes in the human endometrium. *Am. J. Obst. & Gynec.*, **62**, 1100-1105.
- POPÁK, G. 1950. Preparation of solid samples for assay of  $\text{C}^{14}$ . *Biochem. J.*, **46**, 560-561.
- RILLING, H., TCHEN, T. T., AND BLOCH, K. 1958. On the mechanism of squalene biogenesis. *Proc. Nat. Acad. Sci.*, **44**, 167-173.
- RINDANI, T. H. 1958. Influence of testosterone propionate on succinic dehydrogenase activity of male rat liver. *Am. J. Physiol.*, **193**, 73-74.
- ROBERTS, S., AND SZEGO, C. M. 1955a. The influence of steroids on uterine respiration and glycolysis. *J. Biol. Chem.*, **201**, 21-29.
- ROBERTS, S., AND SZEGO, C. M. 1955b. Steroid interactions in the metabolism of reproductive target organs. *Physiol. Rev.*, **33**, 593-629.
- RUDOLPH, G. G., AND SAMUELS, L. T. 1949. Early effects of testosterone propionate on the seminal vesicles of castrate rats. *Endocrinology*, **44**, 190-196.
- RYAN, K. 1958. Conversion of androgens to estrogens by human placental microsomes. *Fed. Proc.*, **17**, 1382.
- RYAN, K. J., AND ENGEL, L. L. 1953. The interconversion of estrone and estradiol-17 $\beta$  by rat liver slices. *Endocrinology*, **52**, 277-286.
- SCHILLER, S., BENDITT, E., AND DORFMAN, A. 1952. Effect of testosterone and cortisone on the hexosamine content and metachromasia of chick combs. *Endocrinology*, **50**, 504-510.
- SOLOMON, S., LEVITAN, P., AND LIEBERMAN, S. 1956. Possible intermediates between cholesterol and pregnenolone in corticosteroidogenesis. Abstract. *Proc. Canad. Physiol. Soc., Rev. Canad. Biol.*, **15**, 282.
- SPAZIANI, E., AND SZEGO, C. M. 1958. The influence of estradiol and cortisol on uterine histamine of the ovariectomized rat. *Endocrinology*, **63**, 669-678.
- STUERMER, V. M., AND STEIN, R. J. 1952. Cytodynamic properties of the human endometrium. V. Metabolism and the enzymatic activity of the human endometrium during the menstrual cycle. *Am. J. Obst. & Gynec.*, **63**, 359-370.
- TALALAY, P., AND WILLIAMS-ASHMAN, H. G. 1958. Activation of hydrogen transfer between pyridine nucleotides by steroid hormones. *Proc. Nat. Acad. Sci.*, **44**, 15-26.
- TALALAY, P., WILLIAMS-ASHMAN, H. G., AND HURLOCK, B. 1958. Steroid hormones as coenzymes of hydrogen transfer. *Science*, **127**, 1060.
- TCHEN, T. T., AND BLOCH, K. 1955. *In vitro* conversion of squalene to lanosterol and cholesterol. *J. Am. Chem. Soc.*, **77**, 6085-6086.
- TELFER, M. A. 1953. Influence of estradiol on nucleic acids, respiratory enzymes and the distribution of nitrogen in the rat uterus. *Arch. Biochem.*, **44**, 111-119.
- VICTOR, J., AND ANDERSEN, D. H. 1937. Stimulation of anterior hypophysis metabolism by theelin or dihydrotheelin. *Am. J. Physiol.*, **120**, 154-166.
- VILLEE, C. A. 1955. An estradiol-induced stimulation of citrate utilization by placenta. *J. Biol. Chem.*, **215**, 171-182.
- VILLEE, C. A. 1957a. Effects of estrogens and antiestrogens *in vitro*. *Cancer Res.*, **17**, 507-511.

- VILLEE, C. A. 1957b. Role of estrogens in regulating the metabolism of the placenta and endometrium. *Fertil. & Steril.*, **8**, 156-163.
- VILLEE, C. A. 1958a. Estrogens and uterine enzymes. *Ann. New York Acad. Sci.*, **75**, 524-534.
- VILLEE, C. A. 1958b. Antagonistic effects of estrogens and thyroxine on an enzyme system *in vitro*. In *Proceedings IV International Congress Biochemistry (Vienna)*, p. 115. London: Pergamon Press.
- VILLEE, C. A., AND GORDON, E. E. 1955. Further studies on the action of estradiol *in vitro*. *J. Biol. Chem.*, **216**, 203-214.
- VILLEE, C. A., AND GORDON, E. E. 1956. The stimulation by estrogens of a DPN-linked isocitric dehydrogenase from human placenta. *Bull. Soc. chim. belg.*, **65**, 186-201.
- VILLEE, C. A., AND HAGERMAN, D. D. 1953. Effects of estradiol on the metabolism of human placenta *in vitro*. *J. Biol. Chem.*, **205**, 873-882.
- VILLEE, C. A., AND HAGERMAN, D. D. 1957. Studies on the estrogen-sensitive isocitric dehydrogenase of the human placenta. In *Proceedings International Symposium Enzyme Chemistry (Japan)*, Vol. 1, p. 287. Tokyo: Maruzen.
- VILLEE, C. A., AND HAGERMAN, D. D. 1958. On the identity of the estrogen-sensitive enzyme of human placenta. *J. Biol. Chem.*, **233**, 42-48.
- VILLEE, C. A., HAGERMAN, D. D., AND JOEL, P. B. 1960. An enzyme basis for the physiologic functions of estrogens. *Recent Progr. Hormone Res.*, **16**, 49-69.
- VILLEE, C. A., JOEL, P. B., LORING, J. M., AND SPENCER, J. M. 1960. Estrogen stimulation of ATP production and protein synthesis. *Fed. Proc.*, **19**, 53.
- VILLEE, C. A., LORING, J. M., AND SARNER, A. 1958. Isocitric dehydrogenases of the placenta. *Fed. Proc.*, **17**, 328.
- WADE, R., AND JONES, H. W., JR. 1956a. Effect of progesterone on mitochondrial adenosine-triphosphatase. *J. Biol. Chem.*, **220**, 547-551.
- WADE, R., AND JONES, H. W., JR. 1956b. Effect of progesterone on oxidative phosphorylation. *J. Biol. Chem.*, **220**, 553-562.
- WALAAS, O., AND WALAAS, E. 1950. The metabolism of uterine muscle studied with radioactive phosphorus  $P^{32}$ . *Acta physiol. scandinav.*, **21**, 18-26.
- WALAAS, O., WALAAS, E., AND LÖKEN, F. 1952a. The effect of estradiol monobenzoate on the metabolism of rat uterine muscle. *Acta endocrinol.*, **10**, 201-211.
- WALAAS, O., WALAAS, E., AND LÖKEN, F. 1952b. The effect of estradiol monobenzoate on the metabolism of the rat endometrium. *Acta endocrinol.*, **11**, 61-66.
- WERBIN, H. AND LEROY, G. V. 1954. Cholesterol: a precursor of tetrahydrocortisone in man. *J. Am. Chem. Soc.*, **76**, 5260-5261.
- WEST, C. D., DAMAST, B. L., SARRO, S. D., AND PEARSON, O. H. 1956. Conversion of testosterone to estrogens in castrated, adrenalectomized human females. *J. Biol. Chem.*, **218**, 409-418.
- WIEST, W. G. 1956. The metabolism of progesterone to  $\Delta^4$ -pregnen-20 $\alpha$ -ol-3-one in oviscerated female rats. *J. Biol. Chem.*, **221**, 461-467.
- ZANDER, J. 1958. Gestagens in human pregnancy. In *Proceedings Conference on Endocrinology of Reproduction*, C. W. Lloyd, Ed. New York: Academic Press, Inc.
- ZONDEK, B., AND HESTRIN, S. 1947. Phosphorylase activity in human endometrium. *Am. J. Obst. & Gynec.*, **54**, 173-175.

# 12

## NUTRITIONAL EFFECTS ON ENDOCRINE SECRETIONS

*James H. Leatham, Ph.D.*

PROFESSOR OF ZOOLOGY, RUTGERS, THE STATE UNIVERSITY,  
NEW BRUNSWICK, NEW JERSEY

I. INTRODUCTION.....	666
II. NATURE OF PROBLEMS IN NUTRITIONAL STUDIES.....	668
A. Thyroid Gland, Nutrition, and Reproduction.....	668
B. Adrenal Gland, Nutrition, and Reproduction.....	670
C. Diabetes Mellitus, Nutrition, and Reproduction.....	672
D. Sterile-Obese Syndrome.....	673
E. Diet and the Liver.....	673
III. HYPOPHYSIS AND DIET.....	674
A. Inanition.....	674
B. Protein.....	675
C. Carbohydrate and Fat.....	676
D. Vitamins.....	676
IV. MALE REPRODUCTIVE SYSTEM.....	677
A. Testis.....	677
1. Inanition.....	677
2. Protein.....	678
3. Fat.....	680
4. Vitamins.....	680
B. Influence of Nutrition on the Responsiveness of Male Reproductive Tissues to Hormones.....	681
1. Testis.....	681
2. Seminal vesicles and prostate.....	682
V. FEMALE REPRODUCTIVE SYSTEM.....	683
A. Ovaries.....	683
1. Inanition.....	683
2. Protein.....	684
3. Carbohydrate.....	685
4. Fat.....	685
5. Vitamins.....	685
B. Influence of Nutrition on the Responsiveness of Female Reproductive Tissues to Hormones.....	687
1. Ovary.....	687
2. Uterus and vagina.....	688
3. Mammary gland.....	689
C. Pregnancy.....	689
VI. CONCLUDING REMARKS.....	693
VII. REFERENCES.....	694

### I. Introduction

Despite the accumulation of many data in the field of reproductive endocrinology during the past 20 years and the long established awareness of a nutritional influence on fertility and fecundity, knowledge bearing on nutrition and the endocrine glands subserving reproduction has advanced comparatively slowly. However, remarkable advances have been made in each speciality so that nutritional-endocrine problems should continue to be a fruitful area for study. Data which have yet to be obtained eventually will contribute to the coherence one would prefer to present now.

The endocrinologist appreciates the delicate balance which exists between the hypophysis and the gonads. In a sense, a similar interdependence exists between nutrition and the endocrine glands, including those with reproductive functions. Not only does nutrition influence synthesis and release of hormones, but hormones in turn, through their regulation of the metabolism of proteins, carbohydrates, and fats, influence nutrition. Thus, dietary deficiencies may create endocrine imbalance, and endocrine imbalance may create demands for dietary factors. It follows, therefore, that, in any consideration of this interrelationship, one must consider not only undernutrition and lack of specific foods, but also possible effects of antithyroid substances in foods, antimetabolites, and overnutrition, especially for the child (Forbes, 1957).

Our understanding of the means by which hormones exert their effects is relatively slight, as is our knowledge of the biochemical mechanisms by which supplements and deficiencies of vitamins and amino acids influence hormone action. Nevertheless, support for the statement that modifications of nutrition influence endocrine gland secretions or hormone action on distant target organs or tissues is provided by an enumeration of a few basic cell components requiring proteins, lipids, and vitamins. (1) Proteins combine with lipids to form lipoproteins which are essential features of the internal and external cellular membranes and interfaces. Hormones, as well as nutrition, influence cell membranes and therefore cell transport is affected. It is well known that hormones influence electrolyte and carbohydrate transfer and recently an endocrine control of amino acid transport was demonstrated (Noall, Riggs, Walker and Christensen, 1957). The effect of modifications of nutrition on the capacity of hormones to influence cell transport must await study. (2) Enzymes are proteins with chemically active surfaces and often include non-protein groups such as vitamins. Nutritional and hormonal changes cause alterations in enzyme concentrations (Knox, Auerbach and Lin, 1956). Vitamin, mineral, and fat deficiencies favor a decrease in enzymes, whereas protein deficiencies have varied effects (Van Pilsun, Speyer and Samuels, 1957). Enzyme changes caused by hormones appear to be a consequence of metabolic adaptations. The importance of a nutritional base on which a hormone can express an effect on the enzymes of the reproductive organs can only be determined after further data have been obtained. (3) Proteins combined with nucleic acids become nucleoproteins, some of which are organized in the cytoplasm and may be templates for cellular protein synthesis. Other nucleoproteins are contained in the nucleus. Nutrition and hormones influence tissue nucleoproteins but studies involving the reproductive organs are few. However, one possible cause of human infertility is low desoxyribose nucleic acid in the sperm (Weir and Leuchtenberger, 1957).

Proteins are characteristic components of

tissues and hypophyscal hormones are protein in nature; also the major portion of gonadal dry weight is protein. Such being the case, it is important to appreciate that the protein composition of the body is in a dynamic state and that proteins from the tissues and from the diet contribute to a common metabolic pool of nitrogen. This metabolic pool contains amino acids which may be withdrawn for rebuilding tissue protein and for the formation of new protein for growth. Obviously, the character of the metabolic pool of nitrogen reflects dietary protein level and quality. A food protein which is deficient in one or more amino acids will restrict tissue protein synthesis. Hormones also influence the metabolic pool by affecting appetite as well as absorption, utilization, and excretion of foods, and thus hormones could accentuate the effect of a poor diet, or create demands beyond those normally met by an adequate diet. In addition a study of the tissues and organs of the body reveals that contributions to the metabolic pool are not uniform, thus one tissue or organ may be maintained at the expense of another. In protein deprivation in adults the liver quickly contributes increased amounts of nitrogen to the metabolic pool whereas the testis does not. On the other hand, protein contributions to the nitrogen pool by the hypophysis, and the amino acid withdrawals needed for hormone synthesis, are unknown. Data suggesting that the addition of specific nutrients to diets improves hypophyscal hormone synthesis have been presented (Leathem, 1958a).

In 1939 Mason rightfully emphasized the need for vitamins in reproduction. Since then, much additional knowledge has been obtained. Vitamins of the B complex have been more clearly identified and a better understanding of their function has been gained. Thiamine is important for carbohydrate metabolism, pyridoxine for fat metabolism, and the conversion of tryptophan to nicotinic acid, and vitamin B<sub>12</sub> may be involved in protein synthesis. In addition, vitamins have been found to serve as cofactors for enzymes, and folic acid to be important for estrogen action on the uterus. These and

many other findings prompt a survey of the relationships of vitamins to reproduction.

It is the intention of the author to review enough of the evidence which interrelates nutrition and reproduction to create an awareness of the problems in the area. Reviews dealing with the general subject of hormonal-nutritional interrelationships have been presented (Hertz, 1948; Samuels, 1948; Ershoff, 1952; Zubiran and Gomez-Mont, 1953; Meites, Feng and Wilwerth, 1957; Leatham, 1958a). Other reviews have related reproduction to nutrition with emphasis on laboratory (Mason, 1939; Guilbert, 1942; Lutwak-Mann, 1958) and farm animals (Reid, 1949; Asdell, 1949), and on protein nutrition (Leatham, 1959b, c). An encyclopedic survey of the biology of human nutrition has been made by Keys, Brozec, Hershchel, Michelsen and Taylor (1950).

## II. Nature of Problems in Nutritional Studies

### A. THYROID GLAND, NUTRITION, AND REPRODUCTION

Normal development of the reproductive organs and their proper functioning in

TABLE 12.1

*Ovarian response to chorionic gonadotrophin, as modified by thiouracil and diet*

(From J. H. Leatham, in *Recent Progress in the Endocrinology of Reproduction*, Academic Press, Inc., New York, 1959.)

Diet	Ovarian Weight	Cholesterol	
		Total	Free
	mg.	%	%
18 per cent casein	87	0.41	0.18
18 per cent + thiouracil	342	0.20	0.12
0 per cent casein	59	0.47	0.23
0 per cent + thiouracil	133	0.22	0.15
18 per cent gelatin	59	0.66	0.22
18 per cent + thiouracil	186	0.26	0.18
Control	27.5	1.56	0.18

Chorionic gonadotrophin = 10 I.U.  $\times$  20 days.

adults are dependent not only on the endocrine glands composing the hypophyseal-gonadal axis, but on others as well. The importance of the thyroid, although not the same for all species, is readily apparent from the effects of prolonged hypo- and hyperthyroid states on reproduction. Many of these effects have been enumerated elsewhere (chapters by Albert, by Young on the ovary, and by Zarrow), but others also are important. Thus steroid production may be altered in hypothyroid animals; certainly its metabolism is influenced. Myxedema is associated with a profound change in androgen metabolism. Endogenous production of androsterone is very low and subnormal amounts of administered testosterone are converted to androsterone. Triiodothyronine corrects this defect (Hellman, Bradlow, Zumoff, Fukushima and Gallagher, 1959). The gonads of male and female offspring of cretin rats are subnormal. The testes may contain a few spermatocytes but no spermatozoa, and Leydig cells seem to secrete little or no androgen. The ovaries may contain a few small follicles with antra, but corpora lutea are absent and ovarian lipid and cholesterol concentrations are very low. Nevertheless, the gonads are competent to respond to administered gonadotrophin with a marked increase in weight. However, administration of chorionic gonadotrophin to the hypothyroid rat stimulated follicular cyst formation rather than folliculogenesis and corpora lutea formation (Leatham, 1958b), but, for even this aberrant development, dietary protein was required (Leatham, 1959b) (Table 12.1). The relationship between hypothyroidism and ovarian function may provide a clue to a possible origin of ovarian cysts, long known to be a common cause of infertility and associated reproductive disorders. Clinical cases of untreated myxedema exhibit ovarian cysts, and rats made hypothyroid for eight months, had a higher percentage of cystic ovaries than did euthyroid rats (Jones, 1944).

The reproductive system of the adult male is less affected than that of the immature male by a decrease in thyroid function, just as the testis of the adult is less likely to reflect a change in protein nutrition which is sufficient to alter the immature rat



testis. On the other hand, the lack of demonstrable thyroid dysfunction in the adult male does not exclude the possibility of an effect of thyroid hormone on reproduction. The conversion of thyroxine to triiodothyronine may be hindered (Morton, 1958). Thyroxine was found to decrease the number of active cells in the semen and to reduce motility, whereas triiodothyronine increased the number of active spermatozoa (Farris and Colton, 1958; Reed, Browning and O'Donnell, 1958). Small dosages of thyroxine stimulated spermatogenesis in the mouse, rabbit, and ram (Maqsood, 1952) and were beneficial in normal guinea pigs and rats (Richter and Winter, 1947; Young, Rayner, Peterson and Brown, 1952).

In many species reproduction occurs despite hypothyroidism, but fecundity may be subnormal (Peterson, Webster, Rayner and Young, 1952). Feeding an antithyroid drug, thiouracil, to female rats may or may not prevent pregnancy, but it reduces the number of young per litter. Thiouracil feeding continued through lactation will decrease litter size (Leathem, 1959b). Hypothyroid guinea pigs gave birth to some live young, but the percentage approached normal only when thyroxine was administered (Hoar, Goy and Young, 1957). Pregnant euthyroid animals responded to thyroxine by delivering more living young than normal control pigs (Peterson, Webster, Rayner and Young, 1952). The extent to which such effects are consequences of the reduction in appetite, metabolism, and absorption of food from the gut which are associated with hypothyroidism has not been determined.

Hyperthyroidism, on the other hand, will increase the appetite and enhance absorption of food from the gut, as the increased metabolism requires more calories, minerals, vitamins, choline, and methionine. In adult rats hyperthyroidism induces a marked loss in body fat and accelerates protein catabolism. The two effects, if unchecked, result in loss of body weight and death. In immature males hyperthyroidism slows gain in body weight, retards testis growth and maturation, and abolishes androgen secretion (Table 12.2). Altering dietary protein in adult animals failed to modify the thyroid hormone effects, thereby suggesting

TABLE 12.2  
*Effects of diet and thyroid (0.2 per cent) on immature rats*  
(From J. H. Leathem, in *Recent Progress in the Endocrinology of Reproduction*, Academic Press, Inc., New York, 1959.)

Diet (Casein) X 30 Days	Testis Weight		Seminal Vesicles
	Actual	Relative	
	mg.	mg. 100 gm	
20 per cent	1694	1035	88
20 per cent + thyroid	1090	881	9
6 per cent	825	1232	16
6 per cent + thyroid	245	650	7
0 per cent	140	346	7
0 per cent + thyroid	95	261	6

that the metabolic demands of other tissues were making increased withdrawals from the metabolic pool of nitrogen and thus hindering testis growth. In euthyroid rats, a 6 per cent protein diet will permit testis growth in the absence of a gain in body weight, but hyperthyroidism prevents this preferential effect. Although Moore (1939) considered the effect of thyroid hormone on reproduction as possibly due to general body emaciation, the testis seems to be less responsive than the body as a whole. Adult rats fed 0.2 per cent desiccated thyroid exhibited no correlation between loss of body weight, change in testis weight, or protein composition of testis at two levels of casein and lactalbumin (Leathem, 1959b). The testes were seemingly not influenced by the metabolic nitrogen changes which caused a loss in carcass nitrogen and an associated increase in kidney and heart nitrogen.

The mechanism of thyroid hormone action on reproduction is far from clear. As we have noted, a part of its action may be through the regulation of nutritional processes. Thyroid function is influenced by the biologic value of the dietary protein (Leathem, 1958a) and the specific amino acids fed (Samuels, 1953). In turn an altered thyroid function will influence the nitrogen contributions to the metabolic pool by reducing appetite and absorption from

the gut, and by changing the contributions of nitrogen to the metabolic pool made by the body tissues. Hypothyroidism interferes with the refilling of body protein stores; consequently, protein needs of the reproductive organs may not be fully met (Leaflum, 1953). It is consistent with this opinion that testis recovery from protein deprivation in hypothyroid rats was aided by thyroxine treatment (Horn, 1955).

Conversion of carotene to vitamin A may be prevented by hypothyroidism, suggesting that a subnormal amount of this vitamin may contribute to fetal loss. An increased intake of B vitamins might be required as hypothyroidism aggravates a vitamin B<sub>12</sub> deficiency, and increased intake of B vitamins enhances the capacity of young rats to withstand large doses of thiouracil (Meites, 1953). Although a reduced metabolic rate might seemingly reduce vitamin requirements, more efficient metabolic activities, in the absence of hormonal stimuli, seem to occur when vitamin intake is increased (Meites, Feng and Wilwerth, 1957).

Reproduction is influenced by effects which are the opposite of a number of those just cited, *i.e.*, effects of malnutrition on thyroid function. The need for iodine in the prevention of goiter is well known. However, certain foods prevent the utilization of iodine in the synthesis of thyroid hormone. The foods containing an anti-thyroid or goitrogenic agent, as tested in man, include rutabaga, cabbage, brussels sprouts, cauliflower, turnip, rape, kale, and to a lesser extent peach, pear, strawberry, spinach, and carrot (Greer and Astwood, 1948). A potent goitrogen isolated from rutabaga is L-5-vinyl-2-thiooxazolidine (Greer, 1950, 1956). Reduced food intake will decrease the thyroid gland response to goitrogens (Gomez-Mont, Paschikis and Cantarow, 1947; Meites and Agrawala, 1949), the uptake of I<sup>131</sup> (Meites, 1953), and the level of thyrotrophic hormone in laboratory animals (D'Angelo, 1951). The thyroid changes associated with malnutrition in man are uncertain (Zubiran and Gomez-Mont, 1953). However, a decreased functioning of the gland in anorexia nervosa, followed by an increased functioning on refeeding (Perloff, Lasche, Nodine,

Schneberg and Vieillard, 1954), is suggestive of a direct nutritional need.

Changes in the thyrotrophic potency of the rat hypophysis have been observed in various vitamin deficiencies. Thiamine deficiency may increase thyroid function, but vitamin A deficiency may have the opposite effect (Ershoff, 1952). The difficulties inherent in the assay of thyroid-stimulating hormone (TSH), even by current methods, prevent one from drawing definite conclusions from the available data.

Immature animals given thyroxine are retarded in growth and do not survive. However, increasing dietary thiamine, pyridoxine, or vitamin B<sub>12</sub> improves the ability of the young rat to withstand large dosages of thyroid substances (Meites, 1952), as does methionine (Boldt, Harper and Elvehjem, 1958). Consideration must also be given to the need for nutritional factors which play a minor role in normal metabolic states but increase in importance in stress. Thus yeast and whole liver contain anti-thyrototoxic substances (Drill, 1943; Ershoff, 1952; Overby, Frost and Fredrickson, 1959).

Excessive thyroid hormone will prevent maturation of the ovary and in adult rats will cause ovarian atrophy with a cessation of estrous cycles. Addition of yeast to the diet permitted estrous cycles to continue (Drill, 1943), but gonadal inhibition in the immature animal was not prevented. However, whole liver or its water-insoluble fraction counteracted the gonadal inhibition induced by hyperthyroidism in immature rats (Ershoff, 1952). Biochemical mechanisms by which these dietary supplements can benefit rats given excessive quantities of hormone are unknown.

#### B. ADRENAL GLAND, NUTRITION, AND REPRODUCTION

The problem of the relationship between adrenal steroid secretions and the reproductive system is one that still requires clarification. Furthermore, the possible influences of nutrition can only be inferred from the effects of adrenal steroids on the major metabolic systems of the body.

In the female there is a close relationship between the adrenal and the estrous and

menstrual cycles (Zuckerman, 1953; chapter by Young on the ovary). The ovary would seem to require cortical steroids for the normal functioning of its own metabolic processes and for those which it influences peripherally. The Addisonian patient may show ovarian follicular atresia and a loss of secondary sex characteristics, and the untreated adrenalectomized rat exhibits a decrease in ovarian size and has irregular cycles (Chester Jones, 1957). The decline in size of the ovary after adrenalectomy is due to impaired sensitivity to follicle-stimulating hormone (FSH) rather than to a decreased production of FSH, and the ovarian response is corrected by cortisone (Mandl, 1954).

Reproductive potential is not necessarily lost when there is adrenal insufficiency, but pregnancy is not well tolerated by women with Addison's disease. Furthermore, adrenalectomy in rats at the time of mating or 4 to 6 days after mating resulted in abortion. Improved pregnancy maintenance was obtained in adrenalectomized rats given saline or cortisone acetate (Davis and Plotz, 1954), whereas desoxycorticosterone acetate alone extended the pregnancy period beyond normal time (Houssay, 1945). Essentially normal pregnancies were obtained in adrenalectomized rats given both cortisone acetate and desoxycorticosterone acetate (Cupps, 1955). Substitution of cortisone acetate for adrenal secretions may be incomplete because the adrenal hormone in the normal rat is primarily corticosterone and because cortisone enhances the excretion of certain amino acids and vitamins. It would be interesting to test a diet with a high vitamin content on the capacity of an adrenalectomized rat to maintain pregnancy, because improved survival of operated rats is obtained by giving vitamin B<sub>12</sub> (Meites, 1953) or large doses of pantothenic acid, biotin, ascorbic acid, or folic acid (Ralli and Dumm, 1952; Dumm and Ralli, 1953).

An adrenal influence over protein metabolism is well known, but protein nutrition, in turn, can influence cortical steroid effectiveness. In fact, an extension of the life span of adrenalectomized rats is not obtained with adrenal steroids if the diet

lacks protein (Leathem, 1958a). A low protein diet alone will not improve survival after adrenalectomy, but better survival is obtained when the rats are given saline. When the low protein diet was supplemented with methionine, a definite improvement in life span was observed and the possibility that cortisone exerts its effect by drawing on the carcass for methionine was suggested (Aschkenasy, 1955a, b).

Reducing dietary casein to 2 per cent seriously endangers pregnancy in the rat, but the addition of progesterone permits 80 per cent of the pregnancies to be maintained. However, removal of the adrenal glands counteracts the protective action of the progesterone, only 10 per cent of the pregnancies continuing to term. Addition of methionine to the low casein diet improved pregnancy maintenance, but 1 mg. cortisone acetate plus progesterone provided the best results (Aschkenasy-Lelu and Aschkenasy, 1957; Aschkenasy and Aschkenasy-Lelu, 1957). These data emphasize the importance of nutrition in obtaining an anticipated hormone action. Further investigation might be directed toward the study of whole proteins other than casein, for the biologic value of proteins differs from normal when tested in adrenalectomized rats (Leathem, 1958a).

As Albert has noted in his chapter, adrenalectomy has little or no effect on the testis. Gaunt and Parkins (1933) found no degenerative changes in the testes of adult rats dying of adrenal insufficiency, although an increase in the testis:body-weight ratios was noted in rats fed 18 per cent and 4 per cent protein (Aschkenasy, 1955c). If adrenalectomized rats are kept on a maintenance dosage of cortisone acetate for 20 days and fed dietary proteins of different biologic values, one finds that testis-composition of protein, lipid, and glycogen varies in the same manner as in the normal rat (Wolf and Leathem, 1955) (Table 12.3).

When the adrenal glands are intact, the influence of diet on their functional capacity and indeed on the hypophysal-adrenal axis must be considered. Zubiran and Gomez-Mont (1953) showed that patients exhibiting gonadal changes associated with chronic malnutrition also exhibit adrenal

TABLE 12.3  
*Nutritional effects on the testes of cortisone-*  
*maintained adrenalectomized rats*  
 (From R. C. Wolf and J. H. Leatham,  
*Endocrinology*, **57**, 286, 1955.)

Treatment	Diet	Testes <i>mg.</i>	Testes Composition (per cent)		
			Protein	Lipid	Glyco- gen
Corti- sone ace- tate	20 per cent casein	703	68.5	30.4	0.13
Control		1211	70.5	29.4	0.15
Corti- sone ace- tate	20 per cent wheat gluten	808	61.0	31.8	0.17
Control		816	62.3	32.2	0.17
Corti- sone ace- tate	20 per cent peanut flour	1014	64.3	31.3	0.17
Control		699	68.5	31.3	0.12

hypofunction. Several clinical tests permitted the evaluation of subnormal adrenal function which, however, did not reach Addisonian levels. Malnutrition not only reduced hypophyseal adrenocorticotrophic hormone (ACTH), but also prevented an incomplete response by the adrenal glands to injected ACTH. In laboratory rodents, anterior hypophyseal function is also influenced by dietary protein and vitamin levels (Ershoff, 1952). The importance of dietary protein in the hypophyseal-adrenal system has recently been re-emphasized (Leatham, 1957; Goth, Nadashi and Slader, 1958). Furthermore, adrenal cortical function is affected by vitamin deficiencies (Morgan, 1951), from which it appears that pantothenic acid is essential for cortical hormone elaboration (Eisenstein, 1957).

Administration of excessive amounts of cortical steroids can induce morphologic changes which have been compared to inanition (Baker, 1952). Not only is nitrogen loss enhanced, but hyperglycemia can also be induced which, therefore, increases the need for thiamine. Cortical steroids influence the metabolism of various vitamins

(Draper and Johnson, 1953; Dhyse, Fisher, Tullner and Hertz, 1953; Aceto, Li Moli and Panebianco, 1956; Ginoullhiac and Nani, 1956). If a vitamin deficiency already exists, administration of cortisone will aggravate the condition (Meites, Feng and Wilwerth, 1957). Nevertheless, drastic effects of therapeutic doses of cortisone on reproductive function do not occur. In rare cases loss of libido has been reported in the male, but morphologic changes in the testis were not observed (Maddock, Chase and Nelson, 1953). Cortisone has little if any effect on the weight of the rat testis (Moore, 1953; Aeshkenasy, 1957) and does not influence testis cholesterol (Migeon, 1952). In the female, menstrual disturbances have been noted in association with cortisone therapy, with the occurrence of hot flashes (Ward, Slocumb, Polley, Lowman and Hensch, 1951). However, cortisone corrected disturbances during the follicular phase, possibly by increasing FSH release (Jones, Howard and Langford, 1953). Cortisone also increased the number of follicles in the ovary of the rat (Moore, 1953), but not in the rabbit. Cortisone administration did not prevent the enhanced ovarian response to chorionic gonadotrophin seen in hypothyroid rats (Leatham, 1958b) and had little effect on mice in parabiosis (Noumura, 1956).

In pregnant female rabbits resorption and stunting of fetuses occurred during treatment with large doses of cortisone (Courrier and Collonge, 1951). Similar effects were noted in mice (LeRoy and Domm, 1951; Robson and Sharaf, 1951).

Some of the metabolic derangements of human toxemia of pregnancy have been correlated with accelerated secretion of adrenal steroids creating a steroid imbalance (see chapter by Zarrow). Cortisone is reported to have a beneficial effect on some cases (Moore, Jessop, O'Donovan, Barry, Quinn and Drury, 1951). Protein inadequacies may also be etiologic in toxemia and further examination of the possibility should be made.

#### C. DIABETES MELLITUS, NUTRITION, AND REPRODUCTION

Glycosuria can be induced experimentally by starvation, overfeeding, and shifting

diets from one of high fat content to one which is isocaloric but high in carbohydrate (Ingle, 1948). Force feeding a high carbohydrate diet will eventually kill a rat despite insulin administration aimed at controlling glycosuria (Ingle and Nezamis, 1947). In man excessive eating leading to obesity increases insulin demand and, in many diabetics of middle age, obesity precedes the onset of diabetes. With our present knowledge we must conclude that overfeeding is wrong when glycosuria exists and that vitamin B supplements may be of value in diabetes (Meites, Feng and Wilwerth, 1957; Salvesen, 1957).

In man urinary 17-ketosteroids and androgen levels are subnormal in diabetes (Horstmann, 1950), and in the diabetic rat pituitary gonadotrophins are reduced (Shipley and Danley, 1947), but testis hyaluronidase does not change (Moore, 1948). When hyperglycemia exists in rats, semen carbohydrates increase (Mann and Lutwak-Mann, 1951).

Hypoglycemia influences the male reproductive organs. In rats tolbutamide or insulin produce lesions of the germinal epithelium which can be prevented by simultaneous administration of glucose. When 2 to 5 hypoglycemic comas are induced, such testis injuries increase progressively in number and frequency, and only a partial return to normal is observed a month later (Mancini, Izquierdo, Heinrich, Penhos and Gerschenfeld, 1959).

It is well known that the incidence of infertility in the pre-insulin era was high in young diabetic women. Fertility is also reduced in diabetic experimental animals, and rat estrous cycles are prolonged (Davis, Fugo and Lawrence, 1947). Insulin is corrective (Sinden and Longwell, 1949; Ferret, Lindan and Morgans, 1950). Pregnancy in women with uncontrolled diabetes may terminate in abortion or stillbirth, possibly because toxemia of pregnancy is high (Pedersen, 1952). In rats pancreatectomy performed the 8th to 12th day of pregnancy increased the incidence of stillbirths (Hultquist, 1950). In another experiment almost one-fourth of 163 animals with diabetes induced by alloxan on the 10th to 12th day of pregnancy died before parturition and

about 25 per cent of the survivors aborted (Angervall, 1959).

#### D. STERILE-OBESE SYNDROME

A sterile-obese syndrome in one colony of mice has been shown to be a recessive monogenic trait (Ingalls, Dickie and Snell, 1950). Obesity was transmitted to subsequent generations by way of ovaries that were transplanted from obese donors to nonobese recipients (Hummel, 1957). Obesity was transmitted by obese females receiving hormonal therapy and mated to obese males kept on restricted food intake (Smithberg and Rummel, 1957). In addition to the investigations of the hereditary nature of the sterile-obese syndrome, the physiologic basis for the sterility has been studied in reference to the presence of germ cells, viability of ova and sperm, integrity of the ovary, and response of the uterus to estrogen (Drasher, Dickie and Lane, 1955). The data indicate that sterility in some obese males can be prevented by food restriction and that sterility in certain obese females can be corrected.

#### E. DIET AND THE LIVER

The concentration of hormones which reaches the target organs in the blood is the result of the rate of their production, metabolism, and excretion. How hypophyscal hormones are destroyed is not clear, but current data make it apparent that pituitary hormones have a short half-life in the circulatory system. Exerting a major control over circulating estrogen levels is the liver, with its steroid-inactivating systems. Zondek (1934) initially demonstrated that the liver could inactivate estrogens and this finding has had repeated confirmation (Cantarow, Paschkis, Rakoff and Hansen, 1943; DeMeio, Rakoff, Cantarow and Paschkis, 1948; Vanderlinde and Westerfield, 1950). Other steroids are also inactivated by the liver with several enzyme systems being involved; the relative concentration of these enzymes varies among species of vertebrates (Samuels, 1949).

The liver is a labile organ which readily responds to nutritional modifications; the induced liver changes alter the steroid-inactivating systems of this organ. Thus, inanition (Drill and Pfeiffer, 1946; Jailer,

1948), vitamin B complex deficiency (Segaloff and Segaloff, 1944; Biskind, 1946), and protein restriction (Jailer and Seaman, 1950) all influence the capacity of the liver to detoxify steroids. Reduced protein intake is a primary factor in decreasing the effectiveness of the steroid-inactivating system (Jailer and Seaman, 1950; Vanderlinde and Westerfield, 1950). Rats fed an 8 per cent casein diet lose their capacity to inactivate estrone within 10 days. However, ascorbic acid alone or in combination with glutathione restored the estrone-inactivating system (Vasington, Parker, Headley and Vanderlinde, 1958).

Failure of steroids to be inactivated will influence the hypophysal-gonadal axis. In turn the excess of estrogen will decrease gonadotrophin production by the hypophysis and thus reduce steroid production by the gonad. In addition nutritional modifications influence hypophysal and possibly gonadal secretory capacity directly. Conceivably, nutritional alterations could modify the amount of steroid secreted or interfere with complete steroid synthesis by a gland.

Fatty infiltration of the liver and a general increase in fat deposition occur in fed and fasted rats after the injection of certain pituitary extracts and adrenal steroids and after the feeding of specific diets. Impaired estrogen inactivation has been associated with a fatty liver, but Szego and Barnes (1943) believe that the major influence is inanition. In fact, estrogens, especially ethinyl estradiol, interfere with fatty infiltration of the liver induced by a low protein diet (György, Rose and Shipley, 1947) or by a choline-deficient diet (Emerson, Zamecnik and Nathanson, 1951). Stilbestrol, however, did not prevent the increase in liver fat induced by a protein-free diet (Glasser, 1957). Estrogens that are effective in preventing fatty infiltration may act by sparing methionine or choline or by inhibiting growth hormone (Plagge, Marasso and Zimmerman, 1958).

Ethionine, the antimetabolite of methionine, will induce a fatty liver and inhibit hepatic protein synthesis in female, but not in male rats (Farber and Segaloff, 1955; Farber and Corban, 1958). Pretreatment of females with testosterone prevents

the ethionine effect, but this blockage of ethionine action need not be related to androgenic or progestational properties of steroids (Ranney and Drill, 1957).

### III. Hypophysis and Diet

Studies involving acute and chronic starvation have shown that gonadal hypofunction during inanition is primarily due to diminished levels of circulating gonadotrophins. Because of the similarity to changes following hypophysectomy, the endocrine response to inanition has been referred to as "pseudohypophysectomy."

#### A. INANITION

The hypophysis has been implicated in human reproduction disturbances associated with undernutrition. Hypophysal atrophy and a decrease in urinary gonadotrophins have been observed in chronic malnutrition (Klimefelter, Albright and Griswold, 1943; Zubiran and Gomez-Mont, 1953) and anorexia nervosa (Perloff, Lasche, Nodine, Schneberg and Vieillard, 1954). Refeeding has restored urinary gonadotrophin levels in some cases, but hypophysal damage may result from severe food restriction at puberty (Vollmer, 1943; Samuels, 1948).

The influence of inanition on the reproductive organs of laboratory rodents is well recognized but the effects on the hypophysis cannot be presented conclusively. In support of prior investigations, Mulinos and Pomerantz (1941a, b) in rats and Giroud and Desclaux (1945) in guinea pigs observed a hypophysal atrophy following chronic underfeeding as well as a decrease in cell numbers and mitoses. In fact, refeeding after chronic starvation resulted in only a partial recovery of hypophysal weight (Quimby, 1948). Nevertheless, complete starvation did not influence relative gland weight in female rats (Meites and Reed, 1949), and cytologic evidence (periodic acid-Schiff (PAS) test) of an estimated 3-fold increase in gonadotrophin content was claimed following chronic starvation (Pearse and Rinaldini, 1950). Assays of hypophysal gonadotrophin content in chronically starved rats of both sexes have been reported as decreased (Mason and Wolfe, 1930; Werner,

1939), unchanged (Marrian and Parkes, 1929; Pomerantz and Mulinos, 1939; Maddock and Heller, 1947; Meites and Reed, 1949; Blivaiss, Hanson, Rosenzweig and McNeil, 1954), or increased (Rinaldini, 1949; Vanderlinde and Westerfield, 1950). An increase in pituitary gonadotrophin was evident when hormone content was related to milligrams of tissue (Meites and Reed, 1949). Thus, the hormone release mechanism may fail in starvation, and eventually gonadotrophin production will be reduced to a minimum (Maddock and Heller, 1947).

Gonadectomy of fully fed rats is followed by an increase in hypophyseal gonadotrophin content. Chronic starvation, however, prevented the anticipated changes in the pituitary gland following gonadectomy in 8 of 12 female rats (Werner, 1939). On the other hand, if adult female rats were subjected to 14 days of reduced feeding 1 month after ovariectomy, no change in the elevated gonadotrophin levels was noted (Meites and Reed, 1949). In contrast, Gomez-Mont (1959) observed above normal urinary gonadotrophins in many menopausal and postmenopausal women despite undernutrition.

It is apparent that uniformity of opinion as to how starvation influences hypophyseal gonadotrophin content has not been attained. Several explanations can be given for the discrepancies. (1) There have been unfortunate variations in experimental design. Maddock and Heller (1947) starved rats for 12 days, whereas Rinaldini (1949) used a low calorie diet of bread and milk for 30 days. Other variations in feeding have included feeding one-half the intake required for growth (Mulinos and Pomerantz, 1941b), regimens of full, one-half, one-quarter, and no feeding for 7 and 14 days (Meites and Reed, 1949), and feeding inadequate amounts of a standard rat diet for 1 to 4 months (Werner, 1939). (2) Hypophyseal implants and anterior pituitary extracts should not be compared, for variable gonadotrophin production may follow implantation procedures, depending on whether necrosis or growth occurs (Maddock and Heller, 1947). (3) There has been an insufficient standardization of experimental materials. The assay animal has usually been the immature female rat, but

occasionally the immature mouse has been used, and Rinaldini (1949) used the hypophysectomized rat.

#### B. PROTEIN

The need for specific food elements by the hypophysis warrants consideration, for the hormones secreted by this gland are protein in nature and the amino acids for protein synthesis must be drawn from body sources. However, dietary protein levels can vary from 15 per cent to 30 per cent without influencing hypophyseal gonadotrophin content in rats (Weatherly and Reece, 1941), but diets containing 80 per cent to 90 per cent of casein increased hypophyseal gonadotrophin (Tuchmann-Duplessis and Aschkenasy-Lelu, 1948). Removal of protein from the diet will decrease hypophyseal gonadotrophin content in adult male rats in comparison with pair-fed and *ad libitum*-fed controls, but the decrease may or may not be significant in a 30-day period; luteinizing hormone (LH) seemed to be initially reduced. Extension of the period of protein depletion another 2 months resulted in a significant lowering of hypophyseal gonadotrophin levels (Table 12.4) (Leathem, 1958a). On the other hand, an increased FSH with no decrease in LH activity was observed in the hypophyses of adult female rats following 30 to 35 days of protein depletion (Srebnik and Nelson, 1957). The available data indicate that not only may a sex difference exist, but also that species may differ; restitution of gonadotrophin in the discharged rabbit pituitary was not influenced by in-

TABLE 12.4

*Influence of a protein-free diet on hypophyseal gonadotrophin content*

(From J. H. Leathem, Recent Progr. Hormone Res., **14**, 141, 1958.)

Days on PFD*	No. of Rats	Anterior Pituitary Weight	Recipient Ovary Weight
		mg.	mg.
0	9	8.3	74
30	9	7.3	54
50	7	7.0	52
90	17	6.0	43

Untreated recipient ovarian weight = 55.0 mg.

\* PFD = Protein-free diet.

adequate dietary protein (Friedman and Friedman, 1940).

When anterior pituitary glands of 60-gm male rats were extracted and administered to immature female recipients, ovarian weight increased from 13.0 to 37.3 mg. After feeding 20 per cent casein or fox chow *ad libitum* for 14 days, the hypophyses of male rats contained almost twice as much gonadotrophin per milligram of tissue as did the hypophyses of the initial controls. Removal of protein from the diet for 14 days, however, reduced hypophyseal gonadotrophin concentration below the level of the initial controls (Leathem and Fisher, 1959).

Data on the hypophyseal hormone content as influenced by specific amino acid deficiencies have not come to the author's attention. Cytologically, however, Scott (1956) noted that an isoleucine-deficient diet depleted the pituitary gonadotrophic cells of their PAS-positive material and reduced the size of acidophilic cells. Omission of threonine, histidine, or tryptophan invoked similar effects. The changes probably represent the interference of a single amino acid deficiency with protein metabolism rather than specific effects attributable to the lack of amino acid itself. Excessive amino acid provided by injecting leucine, methionine, valine, tyrosine, or glycine caused release of gonadotrophin (Goth, Lengyel, Beneze, Saveley and Majsay, 1955).

Administration of 0.1 mg. stilbestrol for 20 days to adult male rats eliminated detectable hypophyseal gonadotrophins. Hormone levels returned during the postinjection period provided the diet contained adequate protein, whereas a protein-free diet markedly hindered the recovery of hypophyseal gonadotrophins. The gonadotrophin content of the pituitary gland correlated well with the recovery of the reproductive system, indicating that gonadotrophin production was subnormal on protein-free feeding (Leathem, 1958a).

#### C. CARBOHYDRATE AND FAT

Reproduction does not appear to be influenced by carbohydrates *per se* and hypophyseal alterations have not been noted.

Fat-deficient diets, however, do influence reproduction and the hypophysis exhibits cellular changes. Pituitary glands of female rats fed a fat-free diet contain a subnormal number of acidophiles and an increased number of basophiles (Panos and Finerty, 1953). In male rats the feeding of a fat-free diet increased hypophyseal basophiles, followed progressively by more castration changes (Finerty, Klein and Panos, 1957; Panos, Klein and Finerty, 1959).

#### D. VITAMINS

Despite the many investigations relating reproduction to vitamin requirements, relatively few have involved hypophyseal hormone estimations. Thus in 1955, Wooten, Nelson, Simpson and Evans reported the first definitive study which related pyridoxine deficiency to hypophyseal gonadotrophin content. Using the hypophysectomized rat for assay, pituitary glands from B<sub>6</sub>-deficient rats were shown to have a 10-fold increase in FSH per milligram of tissue and a slightly increased LH content. Earlier studies had revealed that vitamin B<sub>1</sub>-free diets decreased pituitary gonadotrophins in male rats (Evans and Simpson, 1930) and a similar effect of the folic acid antagonist, aminopterin, in the monkey was found later (Salhanick, Hisaw and Zarrow, 1952).

Male rats deficient in vitamin A exhibited a 43 per cent increase, and castrated vitamin A-deficient rats a 100 per cent increase in hypophyseal gonadotrophin potency over the normal controls (Mason and Wolfe, 1930). The increase of gonadotrophin was more marked in vitamin A-deficient male than in vitamin A-deficient female rats. Associated with the increase in hormone level was a significant increase in basophile cells (Sutton and Brief, 1939; Hodgson, Hall, Sweetman, Wiseman and Converse, 1946; Erb, Andrews, Hauge and King, 1947).

A review of the literature up to 1944 permitted Mason to suggest that the anterior hypophysis was not the instigator of reproductive disturbances in vitamin E deficiency. Nevertheless, Griesbach, Bell and Livingston (1957), in an analysis of the pituitary gland during progressive stages of



tocopherol deprivation, observed cytologic changes in the hypophysis which preceded testis changes. The "peripheral or FSH gonadotrophes" increased in number, size, and activity. The LH cells exhibited a hyperplasia of lesser extent, but possibly sufficient to increase LH in circulation and to cause hypertrophy of the male accessory glands. Gonadotrophic hormone content of pituitary glands from vitamin E-deficient rats may be decreased (Rowlands and Singer, 1936), unchanged (Biddulph and Meyer, 1941), or increased to a level between normal and that of the castrate, when the adult male rats were examined after 22 weeks on a deficient diet (Nelson, 1933; Drummond, Noble and Wright, 1939). Using hypophysectomized male rats as assay animals, evidence was obtained that FSH was increased in the pituitary glands of vitamin E-deficient male and female rats (P'an, Van Dyke, Kaunitz and Slanetz, 1949).

#### IV. Male Reproductive System

##### A. TESTIS

The two basic functions of the male gonads are to produce gametes and secrete steroids. Spermatogenic activity can be estimated from testis morphology and examination of semen samples. Androgen secretion can be estimated from urinary steroid levels, accessory gland weight, and from analyses of accessory sex gland secretions, *i.e.*, fructose and citric acid. In normal maturation in the rabbit, rat, boar, and bull, androgen secretion precedes spermatogenesis (Lutwak-Mann, 1958). On this basis it would appear that well fed young bulls may come into semen production 2 to 3 months sooner than poorly fed animals (Bratton, 1957).

##### 1. Inanition

Complete starvation will prevent maturation of immature animals. Furthermore, marked undernutrition in 700 boys, 7 to 16 years of age, was associated with genital infantilism in 37 per cent and cryptorchidism in 27 per cent (Stephens, 1941). Restriction of food intake to one-half of the normal in maturing bull calves had a

marked delaying effect on the onset of seminal vesicle secretion, but a lesser delaying effect on spermatogenesis (Davies, Mann and Rowson, 1957). Limiting the food intake to one-third of the normal did not prevent the immature rat testis from forming spermatozoa at the same time as their controls (Talbert and Hamilton, 1955). When testis maturation was prevented by inanition, a rapid growth and maturation occurred on refeeding (Ball, Barnes and Visscher, 1947; Quimby, 1948) but Schultze (1955) observed that full body size was not attained.

The reproductive organs of the adult are more resistant to changes imposed by diet than are those of the immature animal. Thus, Mann and Walton (1953) found that 23 weeks of underfeeding produced little change in sperm density and motility in mature animals although seminal vesicle function was reduced. In the male rat testis hypofunction follows partial or complete starvation (Mason and Wolfe, 1930; Mulinos and Pomerantz, 1941a; Escudero, Herreaz and Mussmano, 1948), but there is no reduction in testicular nitrogen (Addis, Poo and Lew, 1936). Loss of Leydig cell function precedes cessation of spermatogenesis (Moore and Samuels, 1931) and is evident by the atrophy of the accessory sexual organs (Mulinos and Pomerantz, 1941a) and by an alteration in accessory gland secretion (Pazos and Huggins, 1945; Lutwak-Mann and Mann, 1950). Evidence of a tubular effect is provided by the lack of motile sperm (Reid, 1949). Severe dietary restriction is associated with the absence of spermatozoa in the seminiferous tubules and epididymis (Mason, 1933; Menze, 1941).

The human male suffering from chronic malnutrition exhibits hypogonadism. The testes atrophy and exhibit a decrease in size of the seminiferous tubules; basement membrane thickening and small Leydig cells are seen. These individuals excrete significantly subnormal amounts of 17-ketosteroids (Zubiran and Gomez-Mont, 1953). Acute starvation may also decrease urinary 17-ketosteroid and androgen levels as much as 50 per cent, with recovery evident on refeeding (Perloff, Lasche, Nodine, Schmeisberg and Vicillard, 1954).

TABLE 12.5

*Effect of 0% on the testes of immature rats*(From J. H. Leatham, in *Reproductive Physiology and Protein Nutrition*, Rutgers University Press, New Brunswick, N. J., 1959.)

Diet (Casein)	No. of Rats	Testis	Weight	Sperm
		mg.	mg./100gm.	%
Initial control	10	329	825	0
20 per cent × 30 days	10	1694	1035	100
6 per cent × 30 days	16	824	890	50
3 per cent × 30 days	12	380	930	0
0 per cent × 30 days	10	140	346	0
0 per cent + 5 per cent liver	10	112	291	0
0 per cent + 5 per cent yeast	10	119	296	0
65 per cent × 30 days	10	1747	1040	100

## 2. Protein

The minimal amount of dietary protein which will support reproduction, lactation, and growth is 16.7 per cent (Goettsch, 1949). Thus, it is not surprising that maturation of testes and accessory sex organs was prevented in immature rats (Horn, 1955) and mice (Leatham and DeFeo, 1952) when they were fed a protein-free diet for 15 to 30 days after weaning. Furthermore, supplements of 5 per cent liver to the casein-free diet had no effect. After a month, the testes, averaging 329 mg., decreased to 140 mg. in rats fed 0 per cent casein, but the weight increased to an average of 1694 mg. and 1747 mg. in rats fed 20 per cent and 65 per cent casein, respectively (Table 12.5). Following protein depletion, there was a decrease in tubular ribonucleic acid and an increase in lipid. Accumulation of gonadal lipid in the inactive testis may be an abnormal assimilation of a degenerative nature or simply nonutilization. A diet containing 6 per cent casein permitted the formation of spermatozoa in some animals (Guilbert and Goss, 1932). When the 6 per cent casein diet was fed to immature animals for 30 days 50 per cent of the rats exhibited some spermatozoa; in addition, testis weight increased slightly and seminal

vesicle weight doubled, but body weight was not improved (Horn, 1955). Thus, as we noted earlier, the reproductive system may gain special consideration for protein allotments when supplies are limited.

Gain in testis weight in immature male rats and the biochemical composition of the immature testis are influenced by the nutritive value of the protein fed. The testes of normal immature rats contain 85 per cent water, 10.5 per cent protein, 4.5 per cent lipid, and detectable glycogen (Wolf and Leatham, 1955). Proteins of lower nutritive value (wheat gluten, peanut flour, gelatin) may permit some increase in testis weight, but testis protein concentration decreased, percentage of water increased, and lipid and glycogen remained unchanged (Table 12.6). The enzyme  $\beta$ -glucuronidase, which has frequently been associated with growth processes, exhibited no change in concentration as the testis matured or was prevented from maturing by a protein-free diet (Leatham and Fisher, 1959). Not only are the weight and composition of the testis influenced by feeding proteins of varied biologic value, but the release of androgen is more markedly altered. When a 22-day-old male rat was fed a 20 per cent casein diet for 30 days, the seminal vesicle and ventral prostate weights increased 9- to 10-fold in comparison with initial control weight. Sub-

TABLE 12.6

*Nutritional effects on testis-composition in immature rats*(From R. C. Wolf and J. H. Leatham, *Endocrinology*, **57**, 286, 1955.)

Diet	No. of Rats	Final Body Weight	Testis			
			Weight	Protein	Fat	Glycogen
			gm.	gm. <sup>c</sup> / <sub>dry</sub>	%	%
20 per cent casein	7	128	1468	72.3	30.4	0.11
20 per cent wheat gluten	8	82	1017	64.6	34.0	0.18
20 per cent peanut flour	8	81	1257	66.1	28.8	0.11
20 per cent gelatin	5	53	210			0.10
5 per cent casein	5	61	684	62.4	29.2	0.26
Fox chow	8	115	1515	70.3	30.3	0.15
Initial control	7	61	273	72.7	30.1	0.19

stitution of wheat gluten and peanut flour for casein, limited the increase in the weight of the seminal vesicles to less than 100 per cent. In fact, seminal vesicle weight as related to body weight did not increase in animals fed 20 per cent wheat gluten.

The withholding of dietary protein from an immature rat for 30 days, during which time maturation occurs in the fully fed animal, did not impose a permanent damage. Refeeding of protein permitted the rapid recovery of testis weight and the appearance of spermatozoa, 70 per cent of all animals having recovered in 30 days when fully fed, whereas only 25 per cent recovered when 6 per cent casein was fed. Recovery of androgen secretion was somewhat slower than that of the tubules as estimated by seminal vesicle weight.

Variations in protein quality are a reflection of amino acid patterns, and amino acid deficiencies interfere with testis maturation (Scott, 1956; Pomeranze, Piliero, Medcei and Plaehla, 1959). Alterations in food intake which follow amino acid deficiencies have required forced feeding or pair-fed controls, but it is clear from what was found in the controls that the gonadal changes were not entirely due to inanition (Ershoff, 1952).

If the diet is varied so that caloric intake per gram is reduced to half while retaining the dietary casein level at 20 per cent, immature rat testis growth is prevented. The effect is unlike that obtained with this level of protein in the presence of adequate calories. Furthermore, the caloric restriction may increase testis glycogen (Leatham, 1959c).

Protein anabolic levels are higher in the tissues of young growing animals and the body is more dependent on dietary protein level and quality for maintenance of the metabolic nitrogen pool than in adult animals. On the other hand, body protein reserves in adult animals permit internal shifts of nitrogen to the metabolic pool and to tissues when dietary sources are reduced or endocrine imbalances are imposed. Thus, Cole, Guilbert and Goss (1932) fed a low protein diet to adult male rats for 60 to 90 days before the sperm disappeared, but the animals would not mate. Amount of semen and sperm produced by sheep have been re-

TABLE 12.7  
*Adult rat testes and seminal vesicles  
after protein depletion*

(From J. H. Leatham, Recent Progr. Hormone Res., **14**, 141, 1958.)

Days on PFD*	No. of Rats	Testis Weight		Protein	Total Protein	Seminal Vesical
		mg.	%			
Control	9	2852	85.9	66.7	0.28	1276
30	9	2600	86.0	66.1	0.24	689
50	7	2398	85.4	64.1	0.22	320
90	25	1429	85.7	69.6	0.13	168

\* PFD = Protein-free diet.

lated to the dietary protein level (Popoff and Okultischew, 1936). Removal of protein from the diet for 30 days had little effect on the adult rat testis weight, spermatogenesis, or nitrogen content (Leatham, 1954). However, seminal vesicle weight was reduced 50 per cent (Aschkenasy, 1954). Prolonged protein depletion was required before the testis exhibited a loss in protein and a reduction in size. A loss of spermatozoa was not observed consistently, although some testes were completely atrophic (Table 12.7). Accessory organ weight decrease reflected the disappearance of androgen (Leatham, 1958a). Interstitial cell atrophy has also been noted in rats fed a low vegetable protein (cassava) diet (Adams, Fernand and Sehnieden, 1958).

Sterility may or may not be induced with diets containing 65 per cent protein (Reid, 1949; Leatham, 1959c) but a 15 to 18 per cent dietary level of a poor protein such as maize or gelatin will decrease sperm motility and increase the number of abnormal sperm. The influence of proteins having different nutritional values in support of the growth of testes from the level to which they were depressed by stilbestrol indicated that casein, lactalbumin, and wheat gluten are equally competent to support testis growth whereas gelatin is deficient. Whole proteins may have several amino acid deficiencies, but the administration of amino acid antagonists may help to identify important individual amino acids. As an example, ethionine causes severe seminiferous tubule atrophy and Leydig cell hypoplasia (Kaufman, Klavins and Kinney, 1956; Goldberg, Pfau and Ungar, 1959). Studies in man have indicated a sharp reduction in

spermatozoa after 9 days on an arginine-deficient diet (Holt, Albanese, Shettles, Kajdi and Wangerin, 1942).

Adequate dietary protein cannot maintain reproductive function if the diet is caloric deficient. Thus, a decrease in seminal vesicle weight could be related to a decrease in dietary calories while protein levels were constant (Rosenthal and Allison, 1956). However, the accessory gland weight loss imposed by caloric restriction could be slowed by increasing the dietary protein (Rivero-Fontan, Pasehki, West and Cantarow, 1952).

Alterations in testis function imposed by inadequate protein are corrected when protein is returned to the diet at normal levels (Aschkenasy and Dray, 1953). Nevertheless, the nutritional state of the animal as a factor influencing recovery has been demonstrated with stilbestrol-treated adult male rats. While being fed an 18 per cent casein diet, adult male rats were injected with 0.1 mg. stilbestrol daily for 20 days. Testis weight decreased from 2848 to 842 mg., spermatogenesis was abolished, and testis water and protein content were significantly reduced. Despite a reduction in food intake, pair-fed controls exhibited no effect on reproductive organs. When a protein-free diet was substituted for the normal diet during the administration of stilbestrol, atrophy of the reproductive system was observed. Cessation of hormone administration was followed by a rapid return of testicular function toward normal when 18 per cent casein was fed both during the injection period and the recovery period. Within 30 days spermatogenesis and testicular composition were fully recovered. However, when 18 per cent casein was fed in the postinjection period to rats that had received a protein-free diet while being given stilbestrol, recovery was clearly slow. After a month, spermatozoa were observed in only 30 per cent of the testes and testis weight was subnormal. Despite the seeming similarity of response by the two nutritional groups during the injection period, the postinjection recovery on identical dietary intake revealed marked differences in rate of recovery (Leatham, 1958a).

### 3. Fat

Linoleic, linolenic, and arachidonic acids are designated as essentially fatty acids, but the physiologic role of these substances is not clearly understood. Nevertheless, the male reproductive organs are influenced by dietary essential fatty acid levels. High fat diets may enhance testicular weight (Kaunitz, Slanetz, Johnson and Guilmain, 1956) whereas removal of fat from the diet resulted in a degeneration of the seminiferous tubules as evidenced by intracellular vacuolation and a reduction in spermatids and spermatozoa (Panos and Finerty, 1954). After 5 months of feeding a fat-free diet, the rat testis may be devoid of sperm (Evans, Lepkovsky and Murphy, 1934). Testis degeneration occurred despite dietary supplements of vitamins A and E and in animals whose health appeared quite normal (Ferrando, Jacques, Mabboux and Prieur, 1955; Ferrando, Jacques, Mabboux and Sollogoub, 1955).

Weanling rats fed 14 per cent arachis (peanut) oil for 15 weeks exhibited a marked impairment of spermatogenesis (Aaes-Jorgensen, Funch and Dam, 1956) and 28 per cent arachis oil induced testicular damage of such an order that 15 weeks of feeding ethyl linoleate did not restore fertility (Aaes-Jorgensen, Funch and Dam, 1957).

### 4. Vitamins

Testicular dysfunction as judged by failure of sperm formation or atrophy of the secondary sex organs has been observed in deprivations of thiamine, riboflavin, pyridoxine, calcium pantothenate, biotin, and vitamins A and E. One must distinguish, however, between effects of inanition associated with a vitamin deficiency and a specific vitamin effect (Skelton, 1950); one must also consider species differences (Biskind, 1946).

There is no question but that vitamin E deficiency in the rat results in a specific and irreversible damage to the testis. Tubular damage may proceed to the point where only Sertoli cells remain and yet the interstitial cells are not influenced (Mason, 1939). Similar changes followed vitamin E deficiency in the guinea pig (Pappenheimer and Schogoleff, 1944; Curto, 1954; Ingel-

man-Sundberg, 1954), hamster (Mason and Mauer, 1957), and bird (Herrick, Eide and Snow, 1952; Lowe, Morton, Cunningham and Vernon, 1957). However, little or no effect of an absence of vitamin E was noted in the rabbit (Mackenzie, 1942) and mouse (Bryan and Mason, 1941), or in live stock (Blaxter and Brown, 1952), or man (Lutwak-Mann, 1958), although vitamin E is present in human testes (Dju, Mason and Filer, 1958). Treatment of low-fertility farm animals with wheat germ oil or tocopherol or the use of this vitamin clinically have provided only inconclusive results (Beckmann, 1955). Although some positive effects have been reported in man, the results may be due in part at least to the sparing action of tocopherol toward vitamin A.

Vitamin A deficiency influences the testis but changes are closely associated with the degree of inanition. In the rat, a vitamin deficiency sufficient to cause ocular lesions did not prevent sperm formation, but a deficiency of such proportions as to cause a body weight loss did cause atrophy of the germinal epithelium (Reid, 1949). Vitamin A deficiency will induce sterility in mice (McCarthy and Cerecedo, 1952). A gross vitamin deficiency in bulls before expected breeding age prevented breeding; adult bulls may exhibit a lower quality semen but they remain fertile (Reid, 1949). Vitamin A deficiency induces metaplastic keratinization of the epithelium lining the male accessory sex organs (Follis, 1948) and thus may influence semen.

Testis damage induced by vitamin A deficiency can be reversed, but vitamin A therapy in man for oligospermia not due to vitamin lack was without effect (Horne and Maddock, 1952).

Age of the animal and dosage are factors which influence the results obtained in male rats with administered vitamin A. Immature male rats given 250 I.U. of vitamin A per gram of body weight daily exhibited a loss of spermatoocytes, an effect which was accentuated by tocopherol (Maddock, Cohen and Wolbach, 1953). Little or no effect of similar treatment was observed in adult rats. The liver is the major storage depot for vitamin A and the fact that the male rat liver is more quickly depleted and less capa-

ble of storage than is the liver of the female should be considered in any attempted correlation of the vitamin and hormone levels (Booth, 1952).

Other vitamin deficiencies have been shown to influence the testis. A lack of thiamine had little effect on testis weight, but did influence the Leydig cells and prevented growth of the accessory sex organs (Pecora and Highman, 1953). A chronic lack of ascorbic acid will cause a degeneration of both Leydig cells and seminiferous tubules. The effects of vitamin deficiency on the testis has been distinguished from those due to inanition and have been related to changes in carbohydrate metabolism (Mukherjee and Banerjee, 1954; Kocen and Cavazos, 1958). The importance of ascorbic acid in the testis as related to function is not evident, but concentrations of this vitamin are maximal at 1 week of age (Coste, Delbarre and Laconique, 1953).

Serious anatomic and functional impairments of testes were noted in pantothenic acid deficiency (Barboriak, Krehl, Cowgill and Whedon, 1957), and development of the rat testis and seminal vesicles was retarded by a biotin deficiency (Bishop and Kosarick, 1951; Katsch, Kosarick and Alpern, 1955), but the animals did not exhibit marked alterations in other endocrine organs (Delost and Terroine, 1954). Testosterone hastened the development of vitamin deficiency and enhanced the severity of biotin deficiency in both sexes, thereby suggesting a hormone-vitamin relationship (Okey, Pencharz and Lepkovsky, 1950). On the other hand, testosterone had no effect on the tolerance of mice for aminopterin, but castration increased the tolerance (Goldin, Greenspan, Goldberg and Schoenberg 1950).

#### B. INFLUENCE OF NUTRITION ON THE RESPONSIVENESS OF MALE REPRODUCTIVE TISSUES TO HORMONES

##### 1. Testis

*a. Inanition.* The testes of birds on limited food intake were more responsive to hypophyseal gonadotrophin than fully fed birds (Byerly and Burrows, 1938; Breneman, 1940). In the rat several investigators have shown that the testis will respond to gonadotrophin despite inanition (Moore and Sam-

TABLE 12.8  
*Influence of diet and pregnant mare serum (PMS) on testes and seminal vesicles of immature male mice*

From V. J. DeFeo and J. H. Leatham, unpublished.)

Diet (Per cent Protein × Days Fed)	PMS	Stage of Spermatogenesis				Seminal Vesicles
		1 <sup>st</sup>	2 <sup>nd</sup>	Sperma-tids	Sperm	
		I.U.				
0 per cent × 10	0	4	3	0	2.7	
0 per cent × 10	3	1	4	1	4.5	
0 per cent × 20	0	1	5	0	2.7	
0 per cent × 20	3	5	2	0	3.5	

uels, 1931; Funk and Funk, 1939; Meites, 1953), with a stimulation of Leydig cells, an increase in testis size, and, in 40 days, a return of spermatozoa. Underfed males injected with gonadotrophin sired litters (Mullinos and Pomerantz, 1941a, b). Improved nutrition aided by unknown liver factors enhanced the response to androgen in severe human oligospermia (Glass and Russell, 1952).

*b. Protein.* Feeding a protein-deficient diet to adult male rats for 60 to 90 days did not prevent stimulation of the testes and seminal vesicles after pregnant mare's serum (PMS) administration (Cole, Guilbert and Goss, 1932). As we have noted, immature animals are prevented from maturing when diets lack protein. Nevertheless, a gonadal response to injected gonadotrophin was obtained in immature mice fed a protein-free diet for 13 days; tubules and Leydig cells were stimulated and androgen was secreted (Table 12.8). Refeeding alone permitted a recovery of spermatogenesis which was not hastened by concomitant PMS (Leatham, 1959c).

The maintenance of testis weight and spermatogenic activity with testosterone propionate in hypophysectomized adult male rats is well known, but these studies have involved adequate nutrition. If hypophysectomized rats were fed a protein-free diet and injected with 0.25 mg. testosterone propionate daily, testis weight and spermatogenesis were less well maintained than in rats fed protein. Testis protein concentra-

tion was also reduced. These data suggest that influences of nutrition on the testis can be direct and are not entirely mediated through hypophyseal gonadotrophin changes (Leatham, 1959b).

*c. Fat.* The rat fed for 20 weeks on a fat-free diet exhibits a degeneration of the seminiferous epithelium within the first weeks which progresses rapidly thereafter. Chorionic gonadotrophin or rat pituitary extract started during the 20th week failed to counteract the tubular degeneration, but testosterone propionate proved effective (Finerty, Klein and Panos, 1957). The result shows that the ineffectiveness of the gonadotrophins could not be due to the failure of androgen release (Greenberg and Ershoff, 1951).

*d. Vitamins.* Gonadotrophins failed to promote spermatogenesis in vitamin A- (Mason, 1939) or vitamin E- (Mason, 1933; Geller, 1933; Drummond, Noble and Wright, 1939) deficient rats, but in another experiment the atrophic accessory sex organs of vitamin A-depleted rats were stimulated (Mayer and Goodard, 1951). Lack of vitamin A favored an enhanced response to PMS when the ratios of seminal vesicle weight to body weight were computed (Meites, 1953). The failure of gonadotrophins to stimulate testis tubules suggests a specific effect of avitaminosis A and E (Mason, 1933) on the responsiveness of the germinal epithelium.

Subnormal responses of rats to PMS, as measured by relative seminal vesicle weight, were obtained when there were individual vitamin B deficiencies, but the influence was due largely to inanition (Drill and Burrill, 1944; Meites, 1953). Nevertheless, sufficient response to chorionic gonadotrophin was obtained so that fructose and citric acid levels were restored to normal. Such an effect was not observed to follow dietary correction unless an unlimited food intake was allowed (Lutwak-Mann, 1958).

## 2. Seminal Vesicles and Prostate

*a. Inanition.* Although the accessory reproductive organs respond to direct stimulation despite an inadequate food intake (Moore and Samuels, 1931), the increase

in weight may be subnormal in mice and rats (Goldsmith, Nigrelli and Ross, 1950; Kline and Dorfman, 1951a, Grayhack and Scott, 1952), or above normal in chickens (Breneman, 1940). Complete deprivation of food reduced the quantity of prostatic fluid in the dog, but exogenous androgen restored the volume, increased acid phosphatase, and induced tissue growth (Pazos and Huggins, 1945).

*b. Protein.* The response of the seminal vesicles to androgen was investigated in immature rats, using weight and  $\beta$ -glucuronidase as end points. Castration and 10 days on a protein-free diet preceded the 72-hour response to 0.25 mg. testosterone propionate. The lack of protein did not prevent a normal weight increase, and enzyme concentration was unchanged. If an 18 per cent diet was fed during the 3-day period that the androgen was acting, no improvement in weight response was noted, but enzyme concentration increased 100 per cent. Thus, when protein stores are depleted, the androgen response may be incomplete in the absence of dietary protein (Leathem, 1959c). Nevertheless, varied protein levels do not influence seminal vesicle weight-response when caloric intake is reduced (Rivero-Fontan, Pashkhis, West and Cantarow, 1952).

*c. Vitamins.* Vitamin deficiencies do not prevent the seminal vesicles from responding to androgen. In fact, in vitamin B deficiency, testosterone restored fructose and citric acid levels to normal despite the need for thiamine in carbohydrate metabolism (Lutwak-Mann and Mann, 1950). In the male, unlike the female, the effects of folic acid deficiency in reducing responsiveness to administered androgen were largely due to inanition in both mice and rats (Goldsmith, Nigrelli and Ross, 1950; Kline and Dorfman, 1951a), and vitamin A deficiency which leads to virtual castration does not prevent an essentially normal response of the accessory glands to testosterone propionate (Mayer and Truant, 1949). Restricting the caloric intake of vitamin A-deficient rats retarded the curative effects of vitamin A in restoring the accessory sex glands of the A-deficient animals (Mason, 1939).

## V. Female Reproductive System

### A. OVARIES

#### 1. Inanition

Mammalian species generally exhibit a delay in sexual maturation when food intake is subnormal before puberty, and ovarian atrophy with associated changes in cycles if inanition is imposed on adults. In human beings a decrease in fertility and a greater incidence of menstrual irregularities were induced by war famine (Zimmer, Weill and Dubois, 1944). Ovarian atrophy with associated amenorrhea and sterility were invoked by chronic undernutrition (Stephens, 1941). The ovarian morphologic changes were similar to those of aging. Urinary estrogens were subnormal in 22 of 25 patients exhibiting amenorrhea associated with limited food intake (Zubiran and Gomez-Mont, 1953).

The nutritional requirements of primates other than man have been studied in female baboons. The intake of vitamins and other essential nutrients was found to be of the same order as that recommended for man. Caloric intake varied with the menstrual cycle, being least during the follicular phase and maximal during the 2 to 7 days preceding menstruation (Gilbert and Gillman, 1956). Various diets were also studied to assess their importance in maintaining the normal menstrual rhythm. The feeding of (a) maize alone, (b) assorted vegetables and fruit, or (c) maize, skimmed milk, and fat led to menstrual irregularities or to amenorrhea. The mechanism regulating ovulation was the first to be deranged. The addition of various vitamins or of animal protein did not correct the menstrual disorders. However, inclusion of ox liver in the diet did maintain the menstrual rhythmicity, but the beneficial effect could not be attributed to its protein content (Gillman and Gilbert, 1956).

In lower mammals that have been studied, inanition will hinder vaginal opening, and delay puberty and ovarian maturation and functioning. In adult rats and mice estrous cycles are interrupted and the reproductive system becomes atrophic when body weight loss exceeds 15 per cent. The cycles be-

come smaller, ovulation fails, and large vesicular follicles decrease in number with an increase in atresia, but primary follicles show a compensatory increase (Marrian and Parkes, 1929; Mulinos and Pomerantz, 1940; Stephens and Allen, 1941; Guilbert, 1942; Bratton, 1957). The ovarian interstitial cells may be markedly altered or absent (Huseby and Ball, 1945; Rinaldini, 1949) and the ovary may exhibit excessive luteinization (Arvy, Aschkenasy, Aschkenasy-Lelu and Gabe, 1946) or regressing corpora lutea (Rinaldini, 1949). However, the ovarian changes induced by inanition may be reversed by refeeding, with a return to reproductive capacity (Ball, Barnes and Visser, 1947; Schultze, 1955). The effect of feed-level on the reproductive capacity of the cow has been reported (El-Skukh, Nulet, Pope and Casida, 1955), but one must realize that high planes of nutrition may adversely influence fertility (Asdell, 1949). Nevertheless, additional protein and calcium added to an adequate diet extended the reproductive life span (Sherman, Pearson, Bal, McCarthy and Lanford, 1956).

## 2. Protein

The availability of just protein has an important influence on the female reproductive system. In immature rats ovarian maturation was prevented by feeding diets containing 0 per cent to 1.5 per cent protein (Ryabinina, 1952) and low protein diets decreased the number of ova but without altering their ribonucleic acid (RNA) or glycogen content (Ishida, 1957). Refeeding 18 per cent protein for only 3 days was marked by the appearance of vesicular follicles and the release of estrogen in mice previously fed a protein-free diet (Leathem, 1958a). In experiments involving the opposite extreme, in which 90 per cent protein diets were used, a retardation of ovarian growth, and a delay in follicular maturation, in vaginal opening, and in the initiation of estrous cycles were noted (Aschkenasy-Lelu and Tuchmann-Duplessis, 1947; Tuchmann-Duplessis and Aschkenasy-Lelu, 1948).

Adult female rats fed a protein-free diet for 30 days exhibited ovaries weighing 22 mg. compared with ovaries weighing 56 mg. from pair-fed controls fed 18 per cent casein. Ovarian glycogen, ascorbic acid, and cho-

lesterol were all influenced by protein deprivation and anestrus accompanied the ovarian changes. Furthermore, uterine weight and glycogen decreased in rats fed protein-free diets (Leathem, 1959b).

In adult rats the feeding of 3.5 per cent to 5 per cent levels of protein (Guilbert and Gross, 1932) was followed by irregularity of the cycles or by their cessation. The cycles became normal when 20 to 30 per cent protein was fed (Aschkenasy-Lelu and Aschkenasy, 1947). However, abnormally high levels of casein (90 per cent) induced prolonged periods of constant estrus (Tuchmann-Duplessis and Aschkenasy-Lelu, 1947). Nevertheless, not all species responded to protein depletion in the same manner. For example, the rabbit exhibited estrus and ovulation despite a 25 per cent body weight loss imposed by 0 to 2 per cent protein diets (Friedman and Friedman, 1940).

Despite a normal level of protein in the diet, inadequate calories will interfere with reproductive function and induce ovarian atrophy (Escudero, Herraiz and Mussmano, 1948; Rivero-Fontan, Paschkis, West and Cantarow, 1952). Furthermore, the effects of 15 per cent and 56 per cent protein levels on estrous cycles could not be distinguished when calories were reduced 50 per cent (Lee, King and Visser, 1952). Returning mice to full feeding after months of calorie deficiency resulted in a sharp increase in reproductive performance well above that expected for the age of the animal (Visser, King and Lee, 1952). This type of rebound phenomenon has not been explained.

Reproductive failure assigned to dietary protein may be a reflection of protein quality as well as level. Specific amino acid deficiencies lead to cessation of estrus (White and White, 1942; Berg and Rohse, 1947) and thus feeding gelatin or wheat as the protein source and at an 18 per cent level was quickly followed by an anestrus (Leathem, 1959b). Supplementation of the wheat diet with lysine corrected the reproductive abnormalities (Courrier and Raynaud, 1932), but neither lysine (Pearson, Hart and Bohstedt, 1937) nor cystine (Pearson, 1936) added to a low casein diet was beneficial. Control of food intake must be considered in studies involving amino



acids, for a deficiency or an excess can create an imbalance and alter appetite. Opportunity to study the amino acids in reproduction is now possible because of the work of Greenstein, Birnbaum, Winitz and Otey (1957) and Schultze (1956), who maintained rats for two or more generations on synthetic diets containing amino acids as the only source of protein. Similarly, the amino acid needs for egg-laying in hens has been reported (Fisher, 1957). Tissue culture methods also permit the study of the nutritional requirements of embryonic gonadal tissue, the success of avian gonadal tissue in culture being judged by survival, growth, and differentiation. In experiments in which this technique was used it was found that a medium made up of amino acids as the basic nitrogen source can maintain gonadal explants very successfully, even though the choice of amino acids does not exactly correspond to the 10 essential amino acids recommended for postnatal growth (Stenger-Haffen and Wolff, 1957).

### 3. Carbohydrate

The absence of dietary carbohydrate does not appreciably affect the regularity of estrous cycles in rats provided the caloric need is met. However, the substitution of 20 per cent sucrose for corn starch induced precocious sexual maturity which was followed by sterility (Whitnah and Bogart, 1956). The ovaries contained corpora lutea, but the excessive luteinization of unruptured follicles suggested a hypophysical disturbance. Substitution of 20 per cent lactose for corn starch had no effect. Increased amounts of lactose retarded the gain in body weight and blocked ovarian maturation, possibly because the animal could not hydrolyze adequate amounts of the disaccharide. Addition of whole liver powder to the diet counteracted the depressing action of 45 per cent lactose on the ovary (Ershoff, 1949).

### 4. Fat

There seems to be little doubt that dietary fat is required for normal cyclic activity, successful pregnancy, and lactation, and that the requirements for essential fatty acids are lower in females than in males (Deuel, 1956).

Conception, fetal development, and par-

turition can take place in animals fed a diet deficient in fatty acids (Deuel, Martin and Alfin-Slater, 1954), despite a reduction in total carcass arachidonic acid (Kummerow, Pan and Hickman, 1952). Earlier reports indicated that a deficiency of essential fatty acids caused irregular ovulation and impaired reproduction (Burr and Burr, 1930; Maeder, 1937). The large pale ovaries lead Sherman (1941) to relate essential fatty acid deficiency to carotene metabolism. In this regard the removal of essential fatty acids from an adequate diet supplemented with vitamin A and E lead to anestrus and sterility while maintaining good health (Ferrando, Jacques, Mabboux and Prieur, 1955). Perhaps the differences in opinion regarding the effects of fatty acid deficiency can be related to the duration of the experimental period. Panos and Finerty (1953) found that growing rats placed on a fat-free diet exhibited a normal time for vaginal opening, normal ovarian weight, follicles, and corpora lutea, although interstitial cells were atrophic. However, regular estrous cycles were noted for only 20 weeks, thereafter 60 per cent of the animals exhibited irregular cycles.

A decrease in reproductive function may be invoked by adding 14 per cent arachis oil to the diet (Aaes-Jorgensen, Funch and Dam, 1956). Increasing dietary fat by adding rape oil did not influence ovarian function but did cause the accumulation of ovarian and adrenal cholesterol (Carroll and Noble, 1952).

Essential fatty acid deficiency is associated with underdevelopment and atrophic changes of the uterine mucosa. Adding fat to a stock diet enhanced uterine weight in young animals at a more rapid pace than body weight (Umberger and Gass, 1958).

### 5. Vitamins

Carotenoid pigments are present in the gonads of many vertebrates and marine invertebrates, and, in mammals, are particularly prominent in the corpus luteum. However, no progress has been made in determining either the importance of the carotenoids in the ovary or of the factors controlling their concentrations. It is well known that vitamin A deficiency induces

a characteristic keratinizing metaplasia of the uterus and vagina, but estrous cycles continue despite the vaginal mucosal changes. Furthermore, ovulation occurs regularly until advanced stages of deficiency appear. The estrous cycle becomes irregular in cattle fed for a long period of time on fodder deficient in carotene. The corpora lutea fail to regress at the normal rate and ovarian follicles become atretic and cystic (Jaskowski, Watkowski, Dobrowolska and Domanski, cited by Lutwak-Mann, 1958). The alterations in reproductive organs associated with a lack of vitamin A may be due in part to a vitamin E deficiency since the latter enhances the rate at which liver stores of vitamin A are depleted.

Definite effects of hypervitaminosis A have been observed on reproduction. Masin (1950) noted that estrus in female rats could be prolonged by administration of 37,000 I.U. of vitamin A daily. The implications, however, have not been studied. The effect of hypervitaminosis A may actually induce secondary hypovitaminoses. The displacement of vitamin K by excess A is almost certain and similar relationships appear to exist with vitamin D (Nieman and Klein Obbink, 1954).

The failure of vitamin E-deficient female rats to become pregnant is apparently due to disturbances of the implantation process rather than to the failure of ovulation. There is no direct proof of ovarian dysfunction (Blandau, Kaunitz and Slanetz, 1949). However, the ovary of the rat deficient in vitamin E may have more connective tissue and pigment, and Kaunitz (1955) showed by ovarian transplantation that some nonspecific ovarian dysfunction appears to exist (cited by Cheng, 1959). Vitamin E is essential for birds, but there is little evidence for a dependency in most mammals; sheep, cows, goats, and pigs have been studied. Treatment of low-fertility farm animals with tocopherol has not provided conclusive data favoring its use (Lutwak-Mann, 1958), nor has the treatment of human females been rewarded with any indication that vitamin E might be helpful in cases of abnormal cycles and habitual abortion (Beckmann, 1955).

No specific reproductive disturbances in man, the rhesus monkey, or the guinea pig

have been associated with vitamin C deficiency (Mason, 1939). Nevertheless, the high ascorbic acid content of ovarian and luteal tissue and of the adrenal cortex suggests a physiologic role in association with steroid synthesis. Ovarian ascorbic acid varies with the estrous cycle, dropping sharply in the proestrus (Coste, Delbarre and Laerionique, 1953), and decreasing in response to gonadotrophin (Höckfelt, 1950; Parlow, 1958). Virtually no ascorbic acid is present in bovine follicular fluid (Lutwak-Mann, 1954) or in rat ovarian cyst fluid (Blye and Leatham, 1959). Uterine ascorbic acid decreased in immature mice treated with estrogen, but remained unchanged in rats following thiouracil administration (Leatham, 1959a). Its role in the uterus awaits elucidation.

Delayed sexual maturation and ovarian atrophy have been described when there are deficiencies of thiamine, riboflavin, pyridoxine, pantothenic acid, biotin, and B<sub>12</sub> (Ershoff, 1952; Ullrey, Becker, Terrill and Notzold, 1955). However, as we noted when deficiencies of the vitamins were being considered, much of the impairment of reproductive function can be related to inanition rather than to a vitamin deficiency (Drill and Burrill, 1944). Pyridoxine deficiency, although not affecting structure (Morris, Dunn and Wagner, 1953), markedly reduces the sensitivity of the ovary to administered gonadotrophin (Wooten, Nelson, Simpson and Evans, 1958).

Bird, frog, and fish eggs contain considerable quantities of vitamins. In fact, the daily human requirements for vitamins may be contained in a hen's egg and thus it is not surprising that hatchability is decreased by virtually any vitamin deficiency. Lutwak-Mann (1958) has provided an excellent survey of these data with numerous references to studies of frogs and fishes. Nearly all the B vitamins are present in fish roe and the pantothenic acid concentration in cod ovaries (*Gadus morrhua*) exceeds most other natural sources. The amount of the latter varies with the reproductive cycle, decreasing to its lowest level before spawning. Riboflavin and vitamin B<sub>12</sub>, on the other hand, do not change (Brackkan, 1955).

B. INFLUENCE OF NUTRITION ON THE RESPONSIVENESS OF FEMALE REPRODUCTIVE TISSUES TO HORMONES

1. Ovary

*a. Inanition.* Marrian and Parkes (1929) were the first to show that the quiescent ovary of the underfed rat can respond to injections of anterior pituitary as evidenced by ovulation and estrous smears. Subsequently the ovaries of underfed birds, rats, and guinea pigs were found to be responsive to serum gonadotrophin (Werner, 1939; Stephens and Allen, 1941; Mulinos and Pomerantz, 1941b; Hosoda, Kaneko, Mogi and Abe, 1956). A low caloric bread-and-milk diet for 30 days did not prevent ovarian response to rat anterior pituitary or to chorionic gonadotrophin. In these animals an increase in ovarian weight with repair of interstitial tissue, as well as follicle stimulation and corpus luteum formation, were observed (Rinaldini, 1949). Rats from which food had been withdrawn for 12 days could respond to castrated rat pituitary extract with an increase in ovarian and uterine weight (Maddock and Heller, 1947). Nevertheless, differences in the time and degree of responsiveness to administered gonadotrophin were noted in rabbits. Animals on a high plane of nutrition responded to gonadotrophin at 12 weeks, whereas rabbits on a low plane of nutrition responded at 20 weeks and fewer eggs were shed (Adams, 1953).

*b. Protein.* Protein or amino acid deficiencies in the rat do not prevent a response to administered gonadotrophin (Cole, Guilbert and Goss, 1932; Courier and Raynaud, 1932). However, the degree and type of gonadal response is influenced by the diet. Thus, immature female mice fed 0 to 6 per cent casein for 13 days exhibited only follicular growth in response to pregnant mare serum, whereas the ovarian response in mice fed 18 per cent casein was suggestive of follicle-stimulating and strongly luteinizing actions (Table 12.9). Furthermore, the ovarian response was significantly less after 20 days of nonprotein feeding than after 10 days of depletion (Leatham, 1958a). Ovarian stimulation by a gonadotrophin involves tissue protein synthesis and thus the type of whole protein fed

could influence the responses. Yamamoto and Chow (1950) fed casein, lactalbumin, soybean, and wheat gluten at 20 per cent levels and noted that the response to gonadotrophin as estimated by tissue nitrogen was related to the nutritive value of the protein. The ovarian weight response to chorionic gonadotrophin was less in rats fed 20 per cent gelatin than those fed 20 per cent casein (Leatham, 1959b). Inasmuch as the hypophysis may influence the gonadal response to injected hormone despite the diet, hypophysectomized rats fed a protein-free diet for 5 weeks and hypophysectomized rats on a complete diet were tested for response to gonadotrophins. The response to FSH was not influenced by diet, but the protein-depleted rats were twice as sensitive to interstitial cell-stimulating hormone (ICSH), human chorionic gonadotrophin (HCG), and PMS as the normal rats (Srebnik, Nelson and Simpson, 1958). Protein-depleted, normal mice were twice as sensitive to PMS as fully fed mice (Leatham and Defeo, 1952).

*c. Vitamins.* In the female vitamin B deficiencies do not prevent ovarian responses to gonadotrophin (Figge and Allen, 1942), but the number of studies is limited. B<sub>6</sub> deficiency in DBA mice was associated with an increased sensitivity of the ovary to gonadotrophins (Morris, Dunn and Wagner, 1953), whereas pyridoxine deficiency in the rat decreased ovarian sensitivity, especially to FSH (Wooten, Nelson, Simp-

TABLE 12.9

*Influence of dietary protein and pregnant mare serum (PMS) on the mouse ovary*

(From J. H. Leatham, Recent Progr. Hormone Res., 14, 141, 1958.)

Diet Per cent Protein × Days Fed:	PMS	Ovarian Weight	No. of Vesicular Follicles	No. of Corpora Lutea	Uterine Weight
0 per cent × 23	0	1.2	0	0	4.8
0 per cent × 23	3	2.8	13	0	10.8
0 per cent × 13	0	1.4	0	0	4.8
0 per cent × 13	3	4.4	16	1	17.1
6 per cent × 13	0	3.2	6	0	7.7
6 per cent × 13	3	5.6	12	1	31.9
18 per cent × 13	0	5.0	10	1	51.6
18 per cent × 13	3	8.0	7	1	51.3

son and Evans, 1958). Administration of vitamin A concomitant with gonadotrophin has been claimed to enhance ovarian response (DiCio and Scheingart, 1942), but in another study the addition of ascorbic acid inhibited the luteinizing and ovulating action of the gonadotrophin (Desaive, 1956).

Whether induced by vitamin deficiency or by inanition, the anestrus in rats which follows 2 to 3 weeks' feeding of a vitamin B-deficient diet has been explored as a method for the assay of gonadotrophin. Pugsley (1957) has shown that there is considerable convenience of method and a satisfactory precision of response for the assay of HCG and pregnant mare serum.

## 2. Uterus and Vagina

*a. Inanition.* Limited food intake does not prevent an increase in uterine weight after estrogen. Testosterone propionate will markedly increase uterine growth despite a 50 per cent reduction in food intake (Leathem, Nocenti and Granitsas, 1956). Furthermore, dietary manipulations involving caloric and protein levels did not prevent the uteri of spayed rats from responding to estrogen (Vanderlinde and Westerfield, 1950). More specific biochemical and physiologic responses must be measured because starvation for 4-day periods clearly interferes with decidual formation (DeFco and Rotheild, 1953). A start in the direction of studying tissue-composition changes has been made by measuring glycogen. However, no changes were noted in uterine glycogen in fasting rats (Walaas, 1952), and estrogen promoted glycogen deposition in the uteri of starved rats as well as in the uteri of fully fed rats (Bo and Atkinson, 1953).

*b. Fat.* Interest in the hormone content of fat from the tissues of animals treated with estrogen for the purpose of increasing body weight has raised the question of tissue hormone content. If estrogen was to be detected in tissues, an increase in dietary fat was necessary. However, the increase in dietary fat decreased the uterine response to stilbestrol (Umberger and Gass, 1958), thus complicating the assay.

*c. Vitamins.* Stimulation of the uterus by estrogen does not require thiamine, ribo-

flavin, pyridoxine, or pantothenic acid. On the other hand, a deficiency of nicotinic acid appears to enhance the response to low doses of estrogen (Kline and Dorfman, 1951a, b). However, B<sub>12</sub> appears to be needed for optimal oviduct response (Kline, 1955) and is required for methyl group synthesis from various one-carbon precursors including serine and glycine (Johnson, 1958).

Response of the bird oviduct to stilbestrol requires folic acid (Hertz, 1945, 1948). It was shown subsequently that stilbestrol and estrone effects in frogs, rats, and the rhesus monkey also require folic acid. A folic acid deficiency can be induced by feeding aminopterin. In this way the estrogen effects can be prevented. Aminopterin also prevents the action of progesterone in decidual formation, from which it may be inferred that folic acid is necessary for decidual formation in the rat. Increased steroid or folic acid levels can reverse the antagonist's effect (Velardo and Hisaw, 1953).

The mechanism of folic acid action is not clear. It may function in fundamental metabolic reactions linked with nucleic acid synthesis. Brown (1953) showed that deoxyribonucleic acid could be substituted for folic acid in the bird. In the rat aminopterin interferes with the increase in uterine nucleic acids, and with nitrogen and P<sup>32</sup> uptake by nucleic acids following estrogen. Folic acid has been implicated in the metabolism of several amino acids (Davis, Meyer and McShan, 1956).

Rats ovariectomized at weaning and maintained on a vitamin E-free diet for 6 weeks to 10 months responded to estradiol in the same manner as rats supplemented with tocopherol. This finding suggests that an intimate physiologic relationship between estradiol and vitamin E is not very probable (Kaunitz, Slanetz and Atkinson, 1949). Nevertheless, vitamin E has been reported to act synergistically with ovarian hormones in decidual formation (Kehl, Douard and Lanfranchi, 1951) and to influence nucleic acid turnover (Dinning, Sime and Day, 1956).

A vitamin-hormone interrelationship is apparent when estrogen and vitamin A are considered. Vitamin A-deficient female rats present evidence of a metaplastic uterine

epithelium in 11 to 13 weeks, but similar changes failed to develop in ovariectomized rats. Vitamin A-deficient castrated rats quickly developed symptoms of metaplasia when estrogen alone was administered, but no adverse effect followed the administration of estrogen combined with vitamin A (Bo, 1955, 1956). The vagina is different. Its epithelium becomes cornified in vitamin A-deficient normal and castrated rats. The cornification is histologically indistinguishable from that occurring in the estrous rat and can be prevented by vitamin A. In fact, vitamin A will quantitatively inhibit the effect of estrogen on the vaginal mucosa when both are applied locally (Kahn, 1954). Conversion of  $\beta$ -carotene to vitamin A is influenced by tocopherol, vitamin B<sub>12</sub>, insulin, and thyroid, with evidence for and against a similar action by cortisone (Lowe and Morton, 1956; Rice and Bo, 1958). An additional vitamin-hormone relationship is suggested by the augmentation of progesterone action in rabbits given vitamin D<sub>2</sub>.

### 3. Mammary Gland

Inanition prevents mammary growth, but feeding above recommended requirements for maintenance and growth from birth to the first parturition also seems to interfere with mammary growth. Furthermore, steroid stimulation of the mammary gland is influenced by nutritional factors. Using the male mouse, Trentin and Turner (1941) showed that as food intake decreased, the amount of estradiol required to produce a minimal duct growth was proportionately increased. In the immature male rat a limited food intake prevented the growth of the mammary gland exhibited by fully fed controls. Nevertheless, the gland was competent to respond to estrogen (Reece, 1950). Inasmuch as the glands of force-fed hypophysectomized rats did not respond to estrogen (Samuels, Reinecke and Peterson, 1941; Ahren, 1959), one can assume that, despite inanition, a hypophyseal factor was present to permit the response of the mammary gland to estrogen. However, inanition (Meites and Reed, 1949), but not vitamin deficiencies (Reece, Turner, Hathaway and Davis, 1937), did reduce the content of hypophyseal lactogen in the rat.

Growth of the mammary gland duct in the male rat in response to estradiol requires a minimum of 6 per cent casein. Protein levels of 3 per cent and 0 per cent failed to support growth of the duct (Reece, 1959).

### C. PREGNANCY

The human male after attaining adulthood is confronted with the problem of maintaining the body tissues built up during the growth period. However, in the human female it has been estimated that the replacement of menstrual losses may require the synthesis of tissue equivalent to 100 per cent of her body weight (Flodin, 1953). In the event of pregnancy and in all viviparous species, the female is presented with even more formidable demands and a limitation of nutritional needs can lead to loss of the embryo or fetus. The role of nutrition at this point in reproduction has always received considerable attention and is complicated by the circumstance that many food substances influence pregnancy (Jackson, 1959). However, in many instances there is no evidence that fetal loss or malformation induced by nutritional modifications has been the consequence of an endocrine imbalance and thus limitation of the immense literature is permissible.

During the first 15 days of pregnancy, a rat may gain 50 gm. Since the fetuses and placentas are small, most of the gain is maternal and is associated with an increase in food intake of as much as 100 calories per kilogram of body weight (Morrison, 1956). During the first 2 weeks of pregnancy, marked storage of fat and water occurs in the maternal body and the animal's positive nitrogen balance is above normal. Liver fat also increases (Shipley, Chudzik, Curtiss and Price, 1953). The increased food intake in early pregnancy may therefore provide a reserve for late fetal growth, as food intake may decline to 65 per cent of the general pregnancy level during the last 7 days (Morrison, 1956). During this last week, fetal growth is rapid. The rapid growth has been related to (1) greater demands of the fetus, (2) greater amounts of food in the maternal blood, and (3) greater permeability of the placenta. Certainly the anabolic potential of fetal tissue is high and the mother can lose weight while the

fetuses gain. But it is also important to recall that there is a shift in protein, because its distribution in organs of pregnant rats differs from that in nonpregnant animals (Pao, Lew and Addis, 1939). Other changes in the maternal organism were enumerated by Newton (1952) and by Souders and Morgan (1957).

A measure of nitrogen balance during pregnancy, rather than weight of young at birth, has been suggested as a means of determining a diet adequate for reproduction (Pike, Suder and Ross, 1954). After the 15th day, a retention of body protein increases, blood amino nitrogen and amino acids decrease, and urea formation decreases. These metabolic activities suggest an increase in growth hormone although the levels of this hormone have not been estimated (Beaton, Ryu and McHenry, 1955). Placental secretions have also been associated with the active anabolic state of the second half of pregnancy, because removal of the fetuses in the rat did not change the anabolic activity, whereas removal of the placentas was followed by a return to normal (Bourdel, 1957). A sharp increase in liver ribose nucleic acid has been observed during late pregnancy in mice and rats and the effect attributed to a placental secretion or to estrogen. Species differences also influence the results because only a modest change in liver RNA was observed in guinea pigs and no change occurred in cats (Campbell and Kosterlitz, 1953; Campbell, Innes and Kosterlitz, 1953a, b).

Clinical observations have related both

toxemia of pregnancy (Pequignot, 1956) and prematurity to inadequate nutrition (Jeans, Smith and Stearns, 1955). The potential role of protein deprivation in the pathogenesis of the toxemia of pregnancy prompted studies in sheep and rats. In sheep nutritionally induced toxemia simulates the spontaneous toxemia (Parry and Taylor, 1956), but only certain aspects of toxemia were observed in the pregnant rat subjected to low protein diets. When rats were fed 5 per cent casein and mated, fluid retention was observed (Shipley, Chudzick, Curtiss and Price, 1953) and pregnancy was completed in only 48 per cent of the animals (Curtiss, 1953). Gain in body weight in the adult rat and gain in fetal weight were subnormal as the result of a low protein feeding during pregnancy.

Complete removal of protein from the diet beginning at the time of mating did not prevent implantation but did induce an 86 to 100 per cent embryonic loss. The effect was not related solely to food intake (Nelson and Evans, 1953), as we will see in what follows when the relationship between protein deficiency and the supply of estrogen and progesterone is described. Limiting protein deprivation to the first 9 to 10 days of pregnancy will also terminate a pregnancy, but when the protein was removed from the diet during only the last week of pregnancy, the maternal weight decreased without an effect on fetal or placental weight (Campbell and Kosterlitz, 1953). As would be anticipated, a successful pregnancy requires protein of good nutritional quality and the caloric intake must be adequate. Thus, an 18 per cent gelatin diet failed to maintain pregnancy when 200 calories per kilogram were fed, whereas a similar level of casein was adequate (Table 12.10). However, reducing caloric intake to 100 calories despite an otherwise adequate protein ration influenced the number and size of fetuses (Leathem, 1959b). Additional proteins should be studied and related to biochemical changes in pregnancy and to the need for specific amino acids; for example, elimination of methionine or tryptophan from the diet may or may not be followed by resorption (Sims, 1951; Kemeny, Handel, Kertesz and Sos, 1953; Albanese, Randall and Holt, 1943). Excretion of 10 amino acids was in-

TABLE 12.10

*Nutrition and pregnancy in rats*

(From J. H. Leathem, in *Recent Progress in the Endocrinology of Reproduction*, Academic Press, Inc., New York, 1959.)

Diet	Calories/kg. Body Weight	Fetuses, Day 20	
		No.	Average weight
			gm.
18 per cent casein	200	8	6.1
18 per cent casein	100	6	3.5
6 per cent casein	250	0	
0 per cent casein	200	0	
18 per cent gelatin	200	0	
18 per cent gelatin	100	0	

creased during normal human pregnancy (Miller, Ruttinger and Macey, 1954).

That a relationship exists, between the dietary requirements just described to the endocrine substances which participate in the control of pregnancy, is suggested by the fact that the deleterious effects of a protein-free diet on pregnancy in rats have been counteracted by the administration of estrone and progesterone. Pregnancy was maintained in 30 per cent, 60 to 80 per cent, and 0 per cent of protein-deficient animals by daily dosages of 0.5  $\mu$ g., 1 to 3  $\mu$ g., and 6  $\mu$ g. estrone, respectively. On the other hand, injection of 4 to 8 mg. progesterone alone maintained pregnancy in 70 per cent of the animals (Nelson and Evans, 1955), and an injection of 4 mg. progesterone with 0.5  $\mu$ g. estrone provided complete replacement therapy (Nelson and Evans, 1954). Food intake did not increase. The results suggest that reproductive failure in the absence of dietary protein was due initially to lack of progesterone and secondarily to estrogen, the estrogen possibly serving as an indirect stimulation for luteotrophin secretion and release. It is well known that hypophysectomy or ovariectomy shortly after breeding will terminate a pregnancy and that replacement therapy requires both ovarian hormones. Thus, the protein-deficient state differs somewhat from the state following hypophysectomy or ovariectomy, but the factors involved are not known.

Pregnancy alters nutritional and metabolic conditions in such a way that labile protein stores of the liver and other parts of the body are influenced, but similar effects are imposed by a transplanted tumor, especially when it reaches 10 per cent of the body weight. Thus, transplantation of a tumor into a pregnant animal would place the fetuses in competition with the tumor for the amino acids of the metabolic pool. Under these circumstances will the pregnancy be maintained? An answer to the question may not yet be given. Nevertheless, Bly, Drevets and Migliarese (1955) observed various degrees of fetal damage in pregnant rats bearing the Walker 256 tumor, and 43 per cent fetal loss was obtained with a small hepatoma (Paselkis and Cantarow, 1958).

Essential fatty acid deficiency, at least in the initial stages, does not interfere with

development of the fetuses or parturition in the rat, but the pups may be born dead or they do not survive more than a few days (Kummerow, Pan and Hickman, 1952). A more pronounced deficiency has induced atrophic changes in the decidua, resorption of fetuses, and prolonged gestation. Death of the fetuses appears to be secondary to placental injury. Hormonal involvement, if any, when there is fatty acid deficiency and pregnancy seems not to have been investigated.

Pregnancy and lactation are major factors influencing vitamin requirements. It is not surprising, therefore, that vitamin deficiencies influence the course of a pregnancy. The subject has recently been reviewed by Lutwak-Mann (1958).

A deficiency of vitamin A does not noticeably affect early fetal development, but later in gestation placental degeneration occurs with hemorrhage and abortion. When the deficiency is moderate the pregnancy is not interrupted, but the fetuses are damaged (Warkany and Schraffenberger, 1944; Wilson, Roth and Warkany, 1953; Giroud and Martinet, 1959). In calves and pigs the abnormalities are associated with the eyes and palate (Guilbert, 1942); in birds skeletal abnormalities are seen (Asmundson and Kratzer, 1952). The use of hormones in an effort to counteract the effects seems to have been attempted only in the rabbit where 12.5 mg. progesterone improved reproduction impaired by vitamin A lack (Hays and Kendall, 1956). Vitamin A excess also proves highly detrimental to pregnancy, as resorption and malformations occur. Administration of excessive vitamin A on days 11 to 13 of pregnancy induced cleft palate in 90 per cent of the embryos (Giroud and Martinet, 1955). In another experiment the effect of excessive vitamin A was augmented by cortisone (Woollam and Millen, 1957).

Vitamin E deficiency has long been known to influence pregnancy in rodents and fetal death appears to precede placental damage and involution of the corpora lutea. Gross observations of the abnormal embryos have been reported (Cheng, Chang and Baben-son, 1957). Estrogen, progesterone, and lactogen were not effective in attempts at corrective therapy (Ershoff, 1943), but estrone and progesterone markedly reduced the in-

evidence of congenital malformations associated with vitamin E lack (Cheng, 1959). In the test of a possible converse relationship, estradiol-induced abortion in guinea pigs was not prevented by vitamin E (Ingelman-Sundberg, 1958).

Fat-soluble vitamins incorporated in the diet may be destroyed by oxidation of the unsaturated fatty acids. To stabilize the vitamins, the addition of diphenyl-*p*-phenylenediamine (DPPD) to the diet has proven successful, but recent studies show that DPPD has an adverse effect on reproduction and thus its use in rat rations is contraindicated (Draper, Goodyear, Barbee and Johnson, 1956).

Vitamin-hormone relationships in pregnancy have been studied with regard to thiamine, pyridoxine, pantothenic acid, and folic acid. Thiamine deficiency induced stillbirths, subnormal birth weights, resorption of fetuses, and loss of weight in the mother. However, as in the case of protein deficiency, pregnancy could be maintained with 0.5  $\mu$ g. estrone and 4 mg. progesterone (Nelson and Evans, 1955). Estrone alone had some favorable effect on the maintenance of pregnancy in thiamine-deficient animals, but it was less effective in protein-deficient animals.

Fetal death and resorptions as well as serum protein and nonprotein nitrogen (NPN) changes similar to those reported for toxemia of pregnancy (Ross and Pike, 1956; Pike and Kirksey, 1959) were induced by a diet deficient in vitamin B<sub>6</sub>. Administration of 1  $\mu$ g. estrone and 4 mg. progesterone maintained pregnancy in 90 per cent of vitamin B<sub>6</sub>-deficient rats (Nelson, Lyons and Evans, 1951). However, the pyridoxine-deficient rat required both steroids to remain pregnant and in this regard resembled the hypophysectomized animal (Nelson, Lyons and Evans, 1953). Nevertheless, a hypophyseal hormone combination which was adequate for the maintenance of pregnancy in the fully fed hypophysectomized rat (Lyons, 1951) was only partially successful when there was a deficiency of pyridoxine. An ovarian defect is suggested.

The folic acid antagonist, 4-amino-pteroylglutamic acid, will rapidly induce the death of early implanted embryos in mice,

rats, and man (Thiersch, 1954). Removal of folic acid from the diet or the addition of x-methyl folic acid will induce malformations when low doses are given and resorptions when high doses are given. Furthermore, this effect is obtained even when the folic acid deficiency is delayed until day 9 of a rat pregnancy or maintained for only a 36-hour period. A deficiency of pantothenic acid will also induce fetal resorption. The vitamin is required for hatching eggs (Gillis, Heuser and Norris, 1942). In animals deficient in folic acid or in pantothenic acid, estrone and progesterone replacement therapy did not prevent fetal loss, suggesting that the hormones cannot act (Nelson and Evans, 1956). In the above mentioned deficiencies replacement of the vitamin is effective. However, vitamins other than those specifically deleted may provide replacement, thus ascorbic acid seems to have a sparing action on calcium pantothenate (Everson, Northrop, Chung and Getty, 1954).

Pregnancy can be interrupted by altering vitamins other than those discussed above, but the hormonal aspects have not been explored. Thus, the lack of choline, riboflavin, and B<sub>12</sub> will induce fetal abnormalities and interrupt gestation (Giroud, Lévy, Lefebvres and Dupuis, 1952; Dryden, Hartman and Cary, 1952; Jones, Brown, Richardson and Sinclair, 1955; Newberne and O'Dell, 1958). Choline lack is detrimental to the placenta (Dubnov, 1958), riboflavin deficiency may impair carbohydrate use (Nelson, Arrrich and Morgan, 1957) and/or induce electrolyte disturbances (Diamant and Guggenheim, 1957), and B<sub>12</sub> spares choline and may be concerned with nucleic acid synthesis (Johnson, 1958). Excessive amounts of B<sub>12</sub> are not harmful. It is interesting to note that uterine secretions and rabbit blastocyst fluid are rich in vitamin B<sub>12</sub> (Lutwak-Mann, 1956), but its presence in such large amounts has not been explained.

An additional substance, lithospermin, extracted from the plant, *Lathyrus odoratus*, is related to hormone functioning; it is antigonadotrophic when eaten by nonpregnant animals and man. The feeding of this substance to pregnant rats terminated the preg-



nancies about the 17th day. Treatment with estrogen and progesterone was preventive (Walker and Wirtschafter, 1956). It is assumed, therefore, that lithospermin interfered with the production of these hormones. A repetition of the experiment on a species in which the hypophysis and ovaries are dispensable during much of pregnancy would be of interest.

In retrospect it has been found that a deficiency in protein and the vitamins thiamine, pyridoxine, pantothenic acid, and folic acid individually can interrupt a pregnancy. Furthermore, a combination of estrone and progesterone which is adequate to maintain pregnancy after hypophysectomy and ovariectomy, is equally effective in protein or thiamine deficiency. This suggests that the basic physiologic alteration is a deprivation of ovarian hormones. However, protein- and thiamine-deficiency states differ from each other as shown by the response to estrogen alone (thiamine deficiency is less responsive), and these states differ from hypophysectomy in which estrone alone has no effect. A pyridoxine deficiency seems to involve both ovary and hypophysis, for neither steroids nor pituitary hormones were more than partially successful in maintaining pregnancy in rats. Lastly, pantothenic acid and folic acid deficiencies may not create a steroid deficiency. What is involved is not known; many possibilities exist. Pantothenic acid, for example, participates in many chemical reactions. Furthermore, it is known that thiamine is essential for carbohydrate metabolism but not for fat metabolism whereas pyridoxine is involved in fat metabolism and in the conversion of tryptophan to nicotinic acid. It is clear, though, that much ground must be covered before the formulation of fruitful hypotheses may be anticipated.

## VI. Concluding Remarks

The development, composition, and normal functioning of the reproductive system is dependent on adequate nutrition. However, the requirements are many and only gradually are data being acquired which are pertinent to the elucidation of the nutritional-gonadal relationship.

The demands for nutrient substances is not always the same. During pregnancy and lactation there is a need for supplemental feeding. A similar need exists in birds and in the many cold-blooded vertebrates in which reproduction is seasonal. Atypical endocrine states create imbalances and a need for nutrient materials which vary, unpredictably, we must acknowledge, until the numerous interrelationships have been clarified.

At many points where determination of cause and effect are possible, an indirect action of dietary factors on reproduction is indicated. No other conclusion seems possible in view of the many instances in which the effect of dietary deficiencies can be counteracted by the administration of a hormone or combination of hormones. The direct action is not immediately apparent; it probably is on the processes by which metabolic homeostasis is maintained, and is in the nature of a lowering of the responsiveness to the stimuli which normally trigger these processes into action. The processes may be those by which pituitary and gonadal hormones are produced or they may be the mechanisms by which these hormones produce their effects on the genital tracts and on the numerous other tissues on which they are known to act.

Because of the many interrelationships, some of which are antagonistic and some supportive, determination of the role of specific dietary substances is not easy. For those who work with laboratory species, the problem is further complicated by the many strain differences. For everyone, the problem is complicated by the many species differences which are the result of an evolution toward carnivorous, herbivorous, or omnivorous diets, to say nothing of the countless specific preferences within each group.

Finally, it is something of a paradox in our culture that much of our effort has been devoted to investigations of the effects of deficiencies and undernutrition rather than to the effects of excesses and overnutrition. Much evidence supports the view that in the aggregate the latter are fully as deleterious as the former, but the means by

which this result is achieved are largely unknown.

## VII. References

- AAES-JORGENSEN, E., FUNCH, J. P., AND DAM, H. 1956. Role of fat in diet of rats; influence on reproduction of hydrogenated arachis oil as sole dietary fat. *Brit. J. Nutrition*, **10**, 317.
- AAES-JORGENSEN, E., FUNCH, J. P., AND DAM, H. 1957. Role of fat in diet of rats; influence of small amount of ethyl linoleate on degeneration of spermatogenic tissue caused by hydrogenated arachis oil as sole dietary fat. *Brit. J. Nutrition*, **11**, 298.
- ACETO, G., LI MOLI, S., AND PANEBIANCO, N. 1956. Influence of adrenocorticotrophin (ACTH) on the urinary excretion of thiamine. *Acta vitaminol.* **10**, 175.
- ADAMS, C. E. 1953. Mammalian germ cells. Ciba Foundation Symposium, 198.
- ADAMS, C. W. M., FERNAND, V. S. V., AND SCHNIEDEN, H. 1958. Histochemistry of a condition resembling kwashiorkor produced in rodents by a low protein-high carbohydrate diet (cassava). *Brit. J. Exper. Path.*, **39**, 393.
- ADDIS, T., POO, L. J., AND LEW, W. 1936. The quantities of protein lost by the various organs and tissues of the body during a fast. *J. Biol. Chem.*, **115**, 111.
- AHREN, K. 1959. The effect of dietary restriction on the mammary gland development produced by ovarian hormones in the rat. *Acta endocrinol.* **31**, 137.
- ALBANESE, A. A., RANDALL, R. M., AND HOLT, L. E., JR. 1943. The effect of tryptophan deficiency on reproduction. *Science*, **97**, 312.
- ANGERVALL, L. 1959. Alloxan diabetes and pregnancy in the rat. Effects on offspring. *Acta Endocrinol.*, suppl. 44, **31**, 86.
- ARVY, L., ASCHKENASY, A., ASCHKENASY-LELU, P., AND GABE, M. 1946. Retentissement d'un régime prolongé d'inanition protéique sur les glandes génitales du rat femelle. *Compt. rend. Soc. biol.*, **140**, 730.
- ASCHKENASY, A. 1954. Action de la testostérone, de la thyroxine et de la cortisone sur l'évolution de l'anémie et de la leucopénie protéoprives. *Le Sang*, **25**, 15.
- ASCHKENASY, A. 1955a. Influence des protéines alimentaires et de divers acides aminés sur la survie et le poids somatique de rats surrénalectomisés et de rats surrénalectomisés-castrés. *Ann. endocrinol.*, **16**, 86.
- ASCHKENASY, A. 1955b. Influence des protéines alimentaires et de divers acides aminés sur la survie et sur le poids somatique de rats surrénalectomisés et de rats surrénalectomisés-castrés. *Ann. endocrinol.*, **16**, 199.
- ASCHKENASY, A. 1955c. Effets de la surrénalectomie sur les poids relatifs de divers organes et tissus. Role du facteur temps et influence de la richesse du régime en protéines. *J. physiol.*, Paris, **47**, 75.
- ASCHKENASY, A. 1957. Effets comparés de l'ACTH, de la cortisone et de la delta-cortisone sur les poids de divers organes et tissus chez le rat male adulte. *Ann. endocrinol.*, **18**, 981.
- ASCHKENASY, A., ASCHKENASY-LELU, P. 1957. Nouvelles recherches sur le rôle des surrénales dans la gestation en régime pauvre en protéines. *Compt. rend. Soc. biol.*, **151**, 880.
- ASCHKENASY, A., AND DRAY, F. 1953. Action de quelques hormones sur la reprise du poids et sur la régénération des organes après inanition protéique expérimentale. *Compt. rend. Soc. biol.*, **147**, 1722.
- ASCHKENASY-LELU, P., AND ASCHKENASY, A. 1947. Influence du taux des protéides de la ration sur le cycle oestral de la rate adulte. Perturbation du cycle avec prolongation des oestrus sous d'action d'un régime hyperprotéidique. *Compt. rend. Soc. biol.*, **141**, 687.
- ASCHKENASY-LELU, P., AND ASCHKENASY, A. 1957. Intervention des surrénales dans la gestation en fonction de la teneur de régime en protéines. *Arch. sc. physiol.*, **11**, 125.
- ASCHKENASY-LELU, P., AND TUCHMANN-DUPLESSIS, H. 1947. Action d'un régime hyperprotéidique sur le développement somatique et sexual de la jeune rate. *Compt. rend. Soc. biol.*, **141**, 1166.
- ASDELL, S. A. 1949. Nutrition and treatment of sterility in dairy cattle: a review. *J. Dairy Sci.*, **32**, 60.
- ASMUNDSON, V. S., AND KRATZER, F. H. 1952. Observations on vitamin A deficiency in turkey breeding stock. *Poultry Sci.*, **31**, 71.
- BAKER, B. L. 1952. Comparison of histological changes induced by experimental hyperadrenocorticalism and inanition. *Recent Progr. Hormone Res.*, **7**, 331.
- BALL, Z. B., BARNES, R. H., AND VISSCHER, M. B. 1947. The effects of dietary caloric restriction on maturity and senescence, with particular reference to fertility and longevity. *Am. J. Physiol.*, **150**, 511.
- BABBORIACK, J. J., KREHL, W. A., COWGILL, G. R., AND WHEEDON, A. D. 1957. Effect of partial pantothenic acid deficiency on reproductive performance of rat. *J. Nutrition*, **63**, 591.
- BEATON, G. H., RYU, M. H., AND McHENRY, E. W. 1955. Studies on the role of growth hormone in pregnancy. *Endocrinology*, **57**, 748.
- BECKMANN, R. 1955. Vitamin E (Physiologie, pathologische Physiologie, klinische Bedeutung). *Ztschr. Vitamin- u. Hormon- u. Fermentforsch.*, **7**, 281.
- BERG, C. P., AND ROHSE, W. G. 1947. Is sterility induced in growing rats on a tryptophan deficient diet? *Science*, **105**, 96.
- BIDDULPH, C., AND MEYER, R. K. 1941. The influence of vitamin E-deficiency on the endocrine glands of rats, particularly on the gonadotropic hormone content of the pituitary gland. *Am. J. Physiol.*, **132**, 259.
- BISHOP, D. W., AND KOSARIK, E. 1951. Biotin deficiency and erythrochidism in rats. *Proc. Soc. Exper. Biol. & Med.*, **78**, 323.
- BISKIND, M. S. 1946. Nutritional therapy of en-

- doctrine disturbances. *Vitamins & Hormones*, **4**, 147.
- BLANDAU, R. J., KAUNTIZ, H., AND SLANETZ, C. A. 1949. Ovulation, fertilization and transport of ova in old vitamin E-deficient rats. *J. Nutrition*, **33**, 97.
- BLAXTER, K. L., AND BROWN, F. 1952. Vitamin E in the nutrition of farm animals. *Nutritional Abstr. & Rev.*, **21**, 1.
- BLIVAISS, B. B., HANSON, R. O., ROSENZWEIG, R. E., AND McNEIL, K. 1954. Sexual development in female rats treated with cortisone. *Proc. Soc. Exper. Biol. & Med.*, **86**, 678.
- BLY, C. G., DREVETS, C., AND MIGLIARESE, J. F. 1955. Competition between fetal growth and transplanted tumor growth in pregnant rats. *Fed. Proc.*, **14**, 399.
- BLYE, R. P., AND LEATHAM, J. H. 1959. Ovarian ascorbic acid in gonadotrophin-treated and normal hypothyroid rats. *Fed. Proc.*, **18**, 49.
- Bo, W. J. 1955. The effect of ovariectomy on metaplastic changes in the uteri of vitamin A deficient rats. *Anat. Rec.*, **121**, 241.
- Bo, W. J. 1956. The relationship between vitamin A deficiency and estrogen in producing uterine metaplasia in the rat. *Anat. Rec.*, **124**, 619.
- Bo, W. J., AND ATKINSON, W. B. 1953. Histochemical studies on glycogen deposition in uterus of the rat. III. Effect of starvation. *Proc. Soc. Exper. Biol. & Med.*, **83**, 405.
- BOLDT, R. E., HARPER, A. E. AND ELVEVJEM, C. A. 1958. The effect of amino acids on the survival of the hyperthyroid rat. *Arch. Biochem.*, **74**, 437.
- BOOTH, V. H. 1952. Liver storage of vitamin A by male and female rats. *J. Nutrition*, **48**, 13.
- BOURDEL, G. 1956. L'anabolisme gravidique: ses caractéristiques son déterminisme. In *Proceedings Fourth International Congress of Nutrition*, p. 37.
- BRAEKKAN, O. R. 1955. Role of pantothenic acid in the reproductive cycle of ovaries in fish. *Nature, London*, **176**, 598.
- BRATTON, R. W. 1957. Nutrition and fertility. *Cornell University Agric. Exper. Sta. Bull.*, **924**, 25.
- BRENNEMAN, W. R. 1940. Limitation of food consumption as a factor influencing endocrine reactions in the chick. *Endocrinology*, **26**, 1091.
- BROWN, W. O. 1953. Effect of deoxy-pentose nucleic acid on impaired oviduct response to oestrogen in the folie acid deficient-chick. *Biochim. et biophys. acta*, **11**, 162.
- BRYAN, W. L., AND MASON, K. E. 1941. Vitamin E deficiency in the mouse. *Am. J. Physiol.*, **131**, 263.
- BURR, G. O., AND BURR, M. M. 1930. On the nature and role of the fatty acids essential in nutrition. *J. Biol. Chem.*, **86**, 587.
- BYERLY, T. C., AND BURROWS, W. H. 1938. Chick testis weight response to gonadotrophic hormone. *Endocrinology*, **22**, 366.
- CAMPBELL, R. M., INNES, I. R., AND KOSTERLITZ, H. W. 1953a. The role of hormonal and dietary factors in the formation of excess ribonucleic acid in the livers of pregnant rats. *J. Endocrinol.*, **9**, 52.
- CAMPBELL, R. M., INNES, I. R., AND KOSTERLITZ, H. W. 1953b. Some dietary and hormonal effects on maternal, fetal and placental weights in the rat. *J. Endocrinol.*, **9**, 68.
- CAMPBELL, R. M., AND KOSTERLITZ, H. W. 1953. Species differences in the deoxyribonucleic and ribonucleic acid contents of livers of non-pregnant and pregnant mice, guinea pigs and cats. *J. Endocrinol.*, **9**, 45.
- CANTAROW, A., PASCHKIS, K. E., RAKOFF, A. E., AND HANSEN, L. P. 1943. Studies on inactivation of estradiol by the liver. *Endocrinology*, **33**, 309.
- CARROLL, K. K., AND NOBLE, R. L. 1952. Effects of feeding rape oil on some endocrine functions of the rat. *Endocrinology*, **51**, 476.
- CHENG, D. W. 1959. Effect of progesterone and estrone on the incidence of congenital malformations due to maternal vitamin E deficiency. *Endocrinology*, **64**, 270.
- CHENG, D. W., CHANG, L. F., AND BAIRNSON, T. A. 1957. Gross observations on developing abnormal embryos induced by maternal vitamin E deficiency. *Anat. Rec.*, **129**, 167.
- CHESTER JONES, I. 1957. *The Adrenal Cortex*. Cambridge: Cambridge University Press.
- COLE, H. H., GUILBERT, H. R., AND GOSS, H. 1932. Further considerations of the properties of the gonad-stimulating principle of mare serum. *Am. J. Physiol.*, **102**, 227.
- COSTE, F., DELBARRE, F., AND LACRONIQUE, F. 1953. Variations du taux de l'acide ascorbiques des endocrines sous l'influence des stimulines hypophysaires. Taux de l'acide ascorbique des testicules du rat en fonction de l'âge. *Compt. rend. Soc. biol.*, **147**, 608.
- COURRIER, R., AND COLLONGE, A. 1951. Cortisone and gestation. *J. A. M. A.*, **146**, 493.
- COURRIER, R., AND RAYNAUD, R. 1932. Modifications génitales chez les animaux a croissance arrêtée par la déficience en lysine. *Compt. rend. Soc. biol.*, **109**, 881.
- CUPPS, P. T. 1955. The ability of certain adrenal steroids to restore reproduction in adrenalectomized female rats. *Endocrinology*, **57**, 1.
- CURTISS, C. 1953. Effects of a low protein intake on the pregnant rat. *Metabolism*, **2**, 344.
- CURRO, G. M. 1954. Experimental vitamin E deficiency in male guinea pigs. *Acta vitaminiol.*, **8**, 7.
- D'ANGELO, S. A. 1951. Effect of acute starvation on the thyrotrophic hormone level in the blood of rat and mouse. *Endocrinology*, **48**, 341.
- DAVIES, D. V., MANN, T., AND ROWSON, L. E. A. 1957. Effect of nutrition on the onset of male sex hormone activity and sperm formation in monozygous bull-calves. *Proc. Roy. Soc. London, ser. B*, **147**, 332.
- DAVIS, J. S., MEYER, R. K., AND McSHAN, W. H. 1956. The effects of aminopterin and estrogen

- on the phosphate metabolism of rat uterus. *Endocrinology*, **59**, 505.
- DAVIS, M. E., FUGG, N. W., AND LAWRENCE, K. G. 1947. Effect of alloxan diabetes on reproduction in the rat. *Proc. Soc. Exper. Biol. & Med.*, **66**, 638.
- DEBIS, M. E., AND PLOTZ, E. J. 1954. The effects of cortisone acetate on intact and adrenalectomized rats during pregnancy. *Endocrinology*, **54**, 384.
- DEFEO, V. J., AND ROTHCHILD, I. 1953. The effects of starvation of intact young rats on deciduoma formation and the maintenance of pseudopregnancy. *Anat. Rec.*, **115**, 297.
- DELOST, P., AND TERROINE, T. 1954. Effets de la carence en biotine sur certaines glandes endocrines au cours du développement post-natal du rat. *Compt. rend. Acad. Sc.*, **239**, 902.
- DEMEIO, R. H., RAKOFF, A. E., CANTAROW, A., AND PASCHKIS, K. E. 1948. Mechanism of inactivation of alpha-estradiol by the rat liver *in vitro*. *Fed. Proc.*, **7**, 27.
- DESAIVE, P. 1956. Du role de la vitamine C dans le fonctionnement de l'ovaire. *Compt. rend. A. anat.*, **42**, 431.
- DEUEL, H. J. 1956. Sex differences in fat and carbohydrate metabolism. *Internat. Ztschr. Vitaminforsch.*, **26**, 352.
- DEUEL, H. J., MARTIN, C. R., AND ALFIN-SLATER, R. B. 1954. The effect of fat level of the diet on general nutrition. *J. Nutrition*, **54**, 193.
- DHYSE, F. G., FISHER, G. R., TULLNER, W. W., AND HERTZ, R. 1953. Liver vitamin content and adrenal cortical function. *Endocrinology*, **53**, 447.
- DIAMANT, E. J., AND GUGGENHEIM, K. 1957. Electrolyte metabolism in pyridoxine, riboflavin and pantothenic acid-deficient rats. *Am. J. Physiol.*, **191**, 108.
- DiCio, A. V., AND SCHTEINGART, M. 1942. The influence of ascorbic acid on the activity of gonadotrophic hormones. *Endocrinology*, **30**, 263.
- DINNING, J. S., SMIE, J. T., AND DAY, P. L. 1956. Increased incorporation of P<sup>32</sup> into nucleic acids by vitamin E-deficient rabbits. *J. Biol. Chem.*, **222**, 215.
- DIU, M. Y., MASON, K. E., AND FILER, L. J. 1958. Vitamin E in human tissues from birth to old age. *Am. J. Clin. Nutrition*, **6**, 50.
- DRAPER, H. H., GOODYEAR, S., BARBEE, K. D., AND JOHNSON, B. C. 1956. Tolerance of the rat for *N,N'*-diphenyl- $\beta$ -phenylethylenediamine. *Proc. Soc. Exper. Biol. & Med.*, **93**, 186.
- DRAPLE, H. H., AND JOHNSON, B. C. 1953. Effect of cortisone on metabolism of certain B vitamins in the rat. *Proc. Soc. Exper. Biol. & Med.*, **82**, 73.
- DRASHER, M. J., DICKIE, M. M., AND LANE, P. W. 1955. Physiologic differences in uteri of obese stock mice. *J. Hered.*, **46**, 209.
- DRILL, V. A. 1943. Interrelations between thyroid function and vitamin metabolism. *Physiol. Rev.*, **23**, 355.
- DRILL, V. A., AND BURRILL, M. W. 1944. Effect of thiamine deficiency and controlled inanition on ovarian function. *Endocrinology*, **35**, 187.
- DRILL, V. A., AND PFEIFFER, C. A. 1946. Effect of vitamin B complex deficiency, controlled inanition and methionine on inactivation of estrogen by the liver. *Endocrinology*, **38**, 300.
- DRUMMOND, J. C., NOBLE, R. L., AND WRIGHT, M. D. 1939. Studies of relationship of vitamin E (tocopherols) to the endocrine system. *J. Endocrinol.*, **1**, 275.
- DRYDEN, L. P., HARTMAN, A. M., AND CARY, C. A. 1952. The effect of vitamin B<sub>12</sub> deficiency upon the survival of young born to rats fed purified casein rations. *J. Nutrition*, **46**, 281.
- DUBNOV, M. V. 1958. Choline-free diets in pregnancy. *Arch. Path.*, **20**, 68.
- DUMI, M. E., AND RALLI, E. P. 1953. Factors influencing the response of adrenalectomized rats to stress. *Metabolism*, **2**, 153.
- EISENSTEIN, A. B. 1957. Effects of dietary factors on production of adrenal steroid hormones. *Am. J. Clin. Nutrition*, **5**, 369.
- EL-SKUKH, A. S., NULET, C. V., POPE, A. L., AND CASIDA, L. E. 1955. The effect of level of feeding on the reproductive capacity of ewe. *J. Anim. Sc.*, **14**, 919.
- EMERSON, W. J., ZAMECNIK, P. C., AND NATHANSON, I. T. 1951. Effect of sex hormones on hepatic and renal lesions induced in rats by a choline-deficient diet. *Endocrinology*, **48**, 548.
- ERB, R. E., ANDREWS, F. N., HAUGE, S. M., AND KING, W. A. 1947. Observations on vitamin A deficiency in young dairy bulls. *J. Dairy Sc.*, **30**, 687.
- ERSHOFF, B. H. 1943. Degeneration of the corpora lutea in the pregnant vitamin E-deficient rat. *Anat. Rec.*, **87**, 297.
- ERSHOFF, B. H. 1949. Beneficial effects of liver on growth and survival of immature rats fed lactose-containing diets. *Proc. Soc. Exper. Biol. & Med.*, **72**, 648.
- ERSHOFF, B. H. 1952. Nutrition and the anterior pituitary with special reference to the general adaptation syndrome. *Vitamins & Hormones*, **10**, 79.
- ESCUDERO, P., HERRAIZ, M. L., AND MUSSMANO, E. 1948. Experimental proof of the first law of nutrition. *Rev. Asoc. argent. Dietol.*, **6**, 195.
- EVANS, H. M., LEPKOVSKY, S., AND MURPHY, E. 1931. Vital need of the body for certain unsaturated fatty acids; reproduction and lactation upon fat-free diets. *J. Biol. Chem.*, **106**, 431.
- EVANS, H. M., AND SIMPSON, M. E. 1930. Subnormal sex-hormone content of the hypophysis of animals with inadequate antineuritic vitamin B. *Anat. Rec.*, **45**, 216.
- EVERSON, G., NORTHROP, L., CHUNG, X. Y., AND GETTY, R. 1954. Effect of ascorbic acid on rats deprived of pantothenic acid during pregnancy. *J. Nutrition*, **54**, 305.
- FAUBER, E., AND CORBAN, M. S. 1958. Sex difference in methionine inhibition of hepatic protein synthesis. *J. Biol. Chem.*, **233**, 625.

- FARBER, E., AND SEGALOFF, A. 1955. Effect of androgens and growth and other hormones on ethionine fatty liver in rats. *J. Biol. Chem.*, **216**, 471.
- FARRIS, E. J., AND COLTON, S. W. 1958. Effects of L-thyroxine and biothyronine on spermatogenesis. *J. Urol.*, **79**, 863.
- FERRANDO, R., JACQUES, F., MABBOUX, H., AND PRIEUR, G. 1955. Influence du torseau d'arachide délipidé par extraction sur la fécondité de la femelle du rat. *Compt. rend. Acad. Sc.*, **241**, 253.
- FERRANDO, R., JACQUES, F., MABBOUX, H., AND SOLOGOUB, C. 1955. Influence du torseau d'arachide délipidé par extraction sur la croissance et l'intégrité des testicules du rat. *Compt. rend. Acad. Sc.*, **241**, 107.
- FERRER, P., LINBAN, O., AND MORGANS, M. E. 1950. Pregnancy in insulin-treated alloxan diabetic rats. *J. Endocrinol.*, **7**, 100.
- FIGGE, F. H. J., AND ALLEN, E. 1942. Genital atrophy during pantothenic acid deficiency and responses to gonadotrophic and estrogenic hormones (Abst.). *Endocrinology*, **30**, 81028.
- FINERTY, J. C., KLEIN, G. F., AND PANOS, T. C. 1957. Effects of hormonal treatment on damaged testes of fat-deficient rats. *Anat. Rec.*, **127**, 293.
- FISHER, H. 1957. The development of a free amino acid diet for the maintenance of egg production in chickens. In *Proceedings Fourth International Congress of Nutrition*, p. 39.
- FLODIN, N. W. 1953. Amino acids and proteins, their place in human nutritional problems. *Agric. & Food Chem.*, **1**, 222.
- FOLLIS, R. H. 1948. *Pathology of Nutritional Diseases*. Springfield, Ill.: Charles C Thomas.
- FORBES, G. B. 1957. Overnutrition for child: blessing or curse. *Nutritional Rev.*, **15**, 193.
- FRIEDMAN, M. H. F., AND FRIEDMAN, G. S. 1940. The relation of diet to the restitution of gonadotrophic hormone content of the discharged rabbit pituitary. *Am. J. Physiol.*, **128**, 493.
- FUNK, C., AND FUNK, I. C. 1939. Action of certain hormones as dietary constituents. *Science*, **90**, 443.
- GAUNT, R., AND PARKINS, W. H. 1933. The alleged interrelationship of the adrenal cortical hormone and the gonads. *Am. J. Physiol.*, **103**, 511.
- GELLER, F. C. 1933. Vitamin E and hormone. *Arch. Gynäk.*, **156**, 345.
- GILBERT, C., AND GILMAN, J. 1956. The changing pattern of food intake and appetite during the menstrual cycle of the baboon (*Papio ursinus*) with a consideration of some of the controlling endocrine factors. *South African J. M. Sc.*, **21**, 75.
- GILLIS, M. B., HEUSER, G. F., AND NORRIS, L. C. 1942. The need for pantothenic acid and an unidentified factor in reproduction in the domestic fowl. *J. Nutrition*, **23**, 153.
- GILMAN, J., AND GILBERT, C. 1956. Menstrual disorders induced in the baboon (*Papio ursinus*) by diet with a consideration of endocrine factors underlying the menstrual disorders and body weight. *South African J. M. Sc.*, **21**, 89.
- GINGOULHAC, E., AND NANI, S. 1956. Urinary excretion of thiamine, cobalamin, pantothenic acid, folic acid, and inosinic acid in rats treated with prednisone. *Acta vitaminol.*, **10**, 157.
- GIROUD, A., AND DESCLAUX, P. 1945. Modifications de l'hypophyse à la suite de la sous-alimentation. *Ann. endocrinol.*, **6**, 107.
- GIROUD, A., LÉVY, G., LEFFEVRES, J., AND DUPUIS, R. 1952. Chute du taux de la riboflavine au stade où se déterminent les malformations embryonnaires. *Internat. Ztschr. Vitamin-Hormon- u. Fermentforsch.*, **23**, 490.
- GIROUD, A., AND MARTINET, M. 1955. Malformations diverses du fœtus de rat suivant les stades d'administration de vitamine A en excès. *Compt. rend. Soc. biol.*, **149**, 1088.
- GIROUD, A., AND MARTINET, M. 1959. Extension à plusieurs espèces de mammifères des malformations embryonnaires par hypervitaminose A. *Compt. rend. Soc. biol.*, **153**, 201.
- GLASS, S. J., AND RUSSELL, M. 1952. Improved spermatogenesis after nutritional-liver regimen with and without testosterone. *Fertil. & Steril.*, **3**, 167.
- GLASSER, S. R. 1957. Influence of a protein-free diet on the immediate and latent effects of stilbestrol. *Am. J. Physiol.*, **189**, 441.
- GOETTSCHE, M. 1949. Minimal protein requirements of the adult rat for 28-day periods of maintenance of body weight. *J. Nutrition*, **45**, 609.
- GOLDBERG, G. M., PFAU, A., AND UNGAR, H. 1959. Effect of testosterone on testicular lesions produced by dl-ethionine in rats. *Am. J. Path.*, **35**, 649.
- GOLDIN, A., GREENSPAN, E. M., GOLDBERG, B., AND SCHOENBERG, E. B. 1950. Studies on the mechanism of action of chemotherapeutic agents in cancer: sex difference in toxicity of the folic acid analogue, 4-aminopteroylglutamic acid. *Cancer*, **3**, 849.
- GOLDSMITH, E. D., NIGRELLI, R. F., AND ROSS, L. 1950. Effects of underfeeding on testosterone action in mice. *Anat. Rec.*, **106**, 197.
- GOMEZ-MONT, F., PASCHKIS, K. E., AND CANTAROW, A. 1947. Thiouracil action in starved rats. *Endocrinology*, **40**, 225.
- GOMEZ-MONT, F. 1959. Endocrine changes in chronic human undernutrition. In *Protein Nutrition and Reproductive Physiology*, p. 58. New Brunswick: Rutgers University Press.
- GOTH, E., LENGYEL, L., BENCSÉ, E., SAVELY, C., AND MAJSAY, A. 1955. The role of amino acids in inducing hormone secretion. *Experientia*, **11**, 27.
- GOTH, E., NADASHI, N., AND SLADER, E. 1958. The effect of amino acids on pituitary-adrenal activity. *Ztschr. Vitamin-Hormon- u. Fermentforsch.*, **9**, 184.
- GRAYHACK, J. T., AND SCOTT, W. W. 1952. The effect of general dietary deficiencies and response of the prostate of the albino rat to

- testosterone propionate. *Endocrinology*, **50**, 406.
- GREENBERG, S. M., AND ERSHOFF, B. H. 1951. Effects of chorionic gonadotrophin on sex organs of male rats deficient in essential fatty acids. *Proc. Soc. Exper. Biol. & Med.*, **78**, 552.
- GRUNSTEIN, J. P., BIRNBAUM, S. M., WINITZ, M., AND OTEY, M. C. 1957. Quantitative nutritional studies with water-soluble chemically defined diet. I. Growth, reproduction and lactation in rats. *Arch. Biochem.*, **72**, 396.
- GREER, M. A. 1950. Nutrition and goiter. *Physiol. Rev.*, **30**, 513.
- GREER, M. A. 1956. Isolation from rutabaga seed of progoinin, the precursor of the naturally occurring antithyroid compound, goitrin (1-5-vinyl-2-thioxazolidone). *J. Am. Chem. Soc.*, **78**, 1260.
- GREER, M. A., AND ASTWOOD, E. B. 1948. The antithyroid effect of certain foods in man as determined with radioactive iodine. *Endocrinology*, **43**, 105.
- GRIESBACH, W. E., BELL, M. E., AND LIVINGSTON, M. 1957. Changes in the pituitary gonadotrophs of the vitamin E-deficient male rat. *Endocrinology*, **60**, 729.
- GUILBERT, H. R. 1942. Some endocrine relationships in nutritional reproductive failure. *J. Animal Sc.*, **1**, 3.
- GUILBERT, H. R., AND GOSS, H. 1932. Some effects of restricted protein intake on the estrous cycle and gestation in the rat. *J. Nutrition*, **5**, 251.
- GYÖRGY, P., ROSE, C. S., AND SHIPLEY, R. A. 1947. Activity of estrone as a lipotropic factor. *Arch. Biochem.*, **12**, 125.
- HAYS, R. L., AND KENDALL, K. A. 1956. Beneficial effect of progesterone on pregnancy in the vitamin A deficient rabbit. *J. Nutrition*, **59**, 337.
- HELLMAN, L., BRADLOW, H. L., ZUMOFF, B., FUKUSHIMA, D. K., AND GALLAGHER, T. F. 1959. Thyroid-androgen interrelations and the hypocholesteremic effect of androsterone. *J. Clin. Endocrinol.*, **19**, 936.
- HERRICK, E. H., EIDE, I. M., AND SNOW, M. R. 1952. Vitamin E in pituitary gland function of fowls. *Proc. Soc. Exper. Biol. & Med.*, **79**, 441.
- HERTZ, R. 1945. The quantitative relationship between stilbestrol response and dietary "folic acid" in the chick. *Endocrinology*, **37**, 1.
- HERTZ, R. 1948. The role of factors of the B-complex in estrogen metabolism. *Recent Progr. Hormone Res.*, **2**, 161.
- HOME, R. M., GOY, R. W., AND YOUNG, W. C. 1957. Loci of action of thyroid hormone on reproduction in the female guinea pig. *Endocrinology*, **60**, 337.
- HODGSON, R. E., HALL, S. R., SWEETMAN, W. J., WISEMAN, H. G., AND CONVERSE, H. T. 1946. The effect of vitamin A deficiency on reproduction in dairy bulls. *J. Dairy Sc.*, **29**, 669.
- HÖKPELT, B. 1950. Changes in the ascorbic acid content of corpus luteum of pregnancy in rabbit after gonadotrophic stimulation. *Acta physiol. scandinav.*, **20**, 172.
- HOLT, L. E., JR., ALBANESE, A. A., SHETTLES, L. B., KAJBI, C., AND WANGERIN, D. M. 1942. Studies of amino acid deficiency in man. *Fed. Proc.*, **1**, 116.
- HORN, E. H. 1955. Nutritional and hormonal influences upon reproductive maturation, organ weight, and histochemistry of the immature male rat. *Endocrinology*, **57**, 399.
- HORNE, H. W., JR., AND MADDOCK, C. L. 1952. Vitamin A therapy in oligospermia. *Fertil. & Steril.*, **3**, 245.
- HORSTMANN, P. 1950. Excretion of androgens in human diabetes mellitus. *Acta endocrinol.*, **5**, 261.
- HOSODA, T., KANEKO, T., MOGI, K., AND ABE, T. 1956. Forced ovulation in gonadotrophin-treated fasting hens. *Proc. Soc. Exper. Biol. & Med.*, **92**, 360.
- HOUSSAY, B. A. 1945. Action of adrenal insufficiency during pregnancy on mother (rats) and offspring. *Rev. Soc. argent. biol.*, **21**, 316.
- HULTQUIST, G. T. 1950. Diabetes and pregnancy: an animal study. *Acta path. et microbiol. scandinav.*, **27**, 695.
- HUMMEL, K. P. 1957. Transplantation of ovaries of the obese mouse. *Anat. Rec.*, **128**, 569.
- HUSEBY, R. A., AND BALL, Z. B. 1945. A study of the genesis of histologic changes produced by caloric restriction in portions of the endocrine and reproductive systems of strain "A" female mice. *Anat. Rec.*, **92**, 135.
- INGALLS, A. M., DICKIE, M. M., AND SNEEL, G. D. 1950. Obese, a new mutation in mouse. *J. Hered.*, **41**, 317.
- INGELMAN-SUNDBERG, A. 1954. Testicles and reproduction in vitamin E-deficient guinea pigs. *Acta endocrinol.*, **17**, 165.
- INGELMAN-SUNDBERG, A. 1958. Failure of vitamin E to prevent placental changes and abruptio placentae in guinea pigs treated with oestrogens and in women suffering from hypertension, chronic renal disease or toxæmia of pregnancy. *Acta endocrinol.*, **27**, 509.
- INGLE, D. J. 1948. The production of experimental glycosuria in the rat. *Recent Progr. Hormone Res.*, **2**, 229.
- INGLE, D. J., AND NEZAMIS, J. E. 1947. The effect of insulin on the tolerance of normal male rats to the overfeeding of a high carbohydrate diet. *Endocrinology*, **40**, 353.
- ISHIDA, K. 1957. Effect of the levels of protein in the diets on the ovaries of the young and adult rats. *Tohoku J. Agric.*, **3**, 17.
- JACKSON, H. 1959. Antifertility substances. *Pharmacol. Rev.*, **11**, 135.
- JAILER, J. W. 1948. The effect of inanition on the inactivation of estrogen by the liver. *Endocrinology*, **43**, 78.
- JAILER, J. W., AND SEAMAN, L. 1950. Estrogen inactivation by the liver as modified by dietary protein. *Proc. Soc. Exper. Biol. & Med.*, **73**, 70.
- JANES, R. G. 1941. Occurrence of follicular cysts in thyroidectomized rats treated with diethylstilbestrol. *Anat. Rec.*, **90**, 93.
- JEANS, P. C., SMITH, M. B., AND STEARNS, G. 1955.

- Incidence of prematurity in relation to maternal nutrition. *J. Am. Dietet. A.*, **31**, 378.
- JOHNSON, B. C. 1958. Studies on the mechanism of action of vitamin B<sub>12</sub> in animal nutrition. *Am. J. Clin. Nutrition*, **6**, 34.
- JONES, C. C., BROWN, S. O., RICHARDSON, L. R., AND SINCLAIR, J. G. 1955. Tissue abnormalities in newborn rats from vitamin B<sub>12</sub>-deficient mothers. *Proc. Soc. Exper. Biol. & Med.*, **90**, 135.
- JONES, G. E. S., HOWARD, J. E., AND LANGFORD, H. 1953. The use of cortisone in follicular phase disturbance. *Fertil. & Steril.*, **4**, 49.
- KAHN, R. H. 1954. Effect of locally applied vitamin A and estrogen on the rat vagina. *Am. J. Anat.*, **95**, 309.
- KATSH, S., KOSARICK, E., AND ALPERN, J. 1955. Effect of biotin deficiency on body and organ growth and accessory reproductive structures in male rats. *Growth*, **19**, 45.
- KAUFMAN, N., KLAVINS, J. V., AND KINNEY, T. D. 1956. Testicular damage following ethionine administration. *Am. J. Pathol.*, **32**, 105.
- KAUNITZ, H., SLANETZ, C. A., AND ATKINSON, W. B. 1949. Estrogen response and pigmentation of the uterus in vitamin E-deficient rat. *Proc. Soc. Exper. Biol. & Med.*, **70**, 302.
- KAUNITZ, H., SLANETZ, C. A., JOHNSON, R. E., AND GUILMAIN, J. 1956. Influence of diet compositions on caloric requirements, water intake and organ weights of rats during restricted food intake. *J. Nutrition*, **60**, 221.
- KEHL, R., DOUARD, T., AND LANFRANCHI, J. 1951. Sur l'action synergique de la vitamine E dans le conditionnement hormonal du déicideuine traumatique, chez la lapine non gestante. *Compt. rend. Soc. biol.*, **145**, 1161.
- KEMENY, T., HANDEL, M. B., KERTESZ, P., AND SOS, J. 1953. Effect of methionine deficiency on fertility in rat. *Kiserletes Orvostudomány*, **5**, 57.
- KEYS, A., BROZEC, J., HERNSCHEL, A., MICHELSEN, O., AND TAYLOR, H. L. 1950. *The Biology of Human Starvation*. Minneapolis: University of Minnesota Press.
- KLINE, I. T. 1955. Relationship of vitamin B<sub>12</sub> to stilbestrol stimulation of the chick oviduct. *Endocrinology*, **57**, 120.
- KLINE, I. T., AND DORFMAN, R. I. 1951a. Testosterone stimulation of seminal vesicles in pteroylglutamic acid-deficient rats. *Endocrinology*, **48**, 34.
- KLINE, I. T., AND DORFMAN, R. I. 1951b. Estrogen stimulation of the oviduct in vitamin-deficient chicks. *Endocrinology*, **48**, 345.
- KLINEFELTER, H. F., JR., ALBRIGHT, F., AND GRISWOLD, G. C. 1943. Experience with quantitative test for normal or decreased amounts of follicle-stimulating hormone in the urine in endocrinological diagnosis. *J. Clin. Endocrinol.*, **3**, 529.
- KNOX, W. E., AUERBACH, V. H., AND LIN, C. C. 1956. Enzymatic and metabolic adaptations in animals. *Physiol. Rev.*, **36**, 164.
- KOCEN, B. P., AND CAVAZOS, L. F. 1958. Cytology of male reproductive tract in scurvy and inanition. *Proc. Soc. Exper. Biol. & Med.*, **98**, 485.
- KUMMEROW, F. A., PAN, H. P., AND HICKMAN, H. 1952. Effect of dietary fat on the reproductive performance and the mixed fatty acid composition of fat-deficient rats. *J. Nutrition*, **46**, 489.
- LEATHEM, J. H. 1953. Relationships between thyroid and protein metabolism. In *Protein Metabolism, Hormones and Growth*, p. 17. New Brunswick: Rutgers University Press.
- LEATHEM, J. H. 1954. Hormonal and nutritional influences on male reproductive system. *Anat. Rec.*, **118**, 323.
- LEATHEM, J. H. 1957. The adrenal and dietary protein. *Arch. internat. pharmacodyn.*, **60**, 103.
- LEATHEM, J. H. 1958a. Hormones and protein nutrition. *Recent Progr. Hormone Res.*, **14**, 141.
- LEATHEM, J. H. 1958b. Hormonal influences on the gonadotrophin sensitive hypothyroid rat ovary. *Anat. Rec.*, **131**, 487.
- LEATHEM, J. H. 1959a. Some biochemical aspects of the uterus. *Ann. New York Acad. Sc.*, **75**, 463.
- LEATHEM, J. H. 1959b. Extragonadal factors in reproduction. In *Recent Progress in the Endocrinology of Reproduction*, p. 179. New York: Academic Press, Inc.
- LEATHEM, J. H. 1959c. The male reproductive system and protein nutrition. In *Reproductive Physiology and Protein Nutrition*, p. 22. New Brunswick: Rutgers University Press.
- LEATHEM, J. H., AND DEFEQ, V. J. 1952. Responses of the mouse gonad to equine pituitary gonadotrophin as influenced by dietary protein restriction. *Anat. Rec.*, **112**, 356.
- LEATHEM, J. H., AND FISHER, C. J. 1959. Male rat reproductive system and protein nutrition. *Anat. Rec.*, **133**, 302.
- LEATHEM, J. H., NOCENTI, M. R., AND GRANITSAS, A. 1956. Effect of testosterone propionate and diets supplemented with methionine on body weight and organ weights of female rats. *Proc. Pennsylvania Acad. Sc.*, **30**, 38.
- LEE, Y. C. P., KING, J. T., AND VISSCHER, M. B. 1952. Influence of protein and caloric intake upon certain reproductive functions and carcinogenesis in the mouse. *Am. J. Physiol.*, **168**, 391.
- LEROY, P., AND DOMM, L. V. 1951. Observations on cortisone administration in normal and decapitated fetal rats. *Anat. Rec.*, **109**, 319.
- LOWE, J. S., AND MORTON, R. A. 1956. Some aspects of vitamin A metabolism. *Vitamins & Hormones*, **14**, 97.
- LOWE, J. S., MORTON, R. A., CUNNINGHAM, N. E., AND VERNON, J. 1957. Vitamin A deficiency in domestic fowl. *Biochem. J.*, **67**, 215.
- LUTWAK-MANX, C. 1954. Note on the chemical composition of bovine follicular fluid. *J. Agric. Sc.*, **44**, 477.
- LUTWAK-MANX, C. 1956. Biochemical relationships between the early rabbit embryo and its environment. In *Third International Congress*

- on *Animal Reproduction*, p. 50. London: Brown, King & Tuscott, Ltd.
- LUTWAK-MANN, C. 1958. Dependence of gonadal function upon vitamins and other nutritional factors. *Vitamins & Hormones*, **16**, 35.
- LUTWAK-MANN, C., AND MANN, T. 1950. Restoration of secretory function in male accessory glands of vitamin B-deficient rats by means of chorionic gonadotrophin. *Nature*, London, **165**, 556.
- LYONS, W. R. 1951. Maintenance of pregnancy in hypophysectomized rats. *Anat. Rec.*, **109**, 378.
- MACKENZIE, C. G. 1942. Cure of repeated attacks of nutritional muscular dystrophy in the rabbit by  $\alpha$ -tocopherol. *Proc. Soc. Exper. Biol. & Med.*, **49**, 313.
- MADDOCK, C. L., COHEN, J., AND WOLBACH, S. R. 1953. Effect of hypervitaminosis A on the testes of the rat. *Arch. Path.*, **56**, 333.
- MADDOCK, W. O., CHASE, J. D., AND NELSON, W. O. 1953. Effects of large doses of cortisone on testicular morphology and urinary gonadotrophin, estrogen, 17-ketosteroid excretion. *J. Lab. & Clin. Med.*, **41**, 608.
- MADDOCK, W. O., AND HELLER, C. G. 1947. Dichotomy between hypophyseal content and amount of circulating gonadotrophins during starvation. *Proc. Soc. Exper. Biol. & Med.*, **66**, 595.
- MCCARTHY, P. T., AND CERECEDO, L. R. 1952. Vitamin A deficiency in the mouse. *J. Nutrition*, **46**, 361.
- MAEDER, E. C. 1937. The effect of fat in simplified diets on the reproductive organs of the female albino rat during gestation. *Anat. Rec.*, **70**, 73.
- MANCINI, R. E., IZQUIERDO, I. A., HEINRICH, J. J., PENHOS, J. C., AND GERSCHENFELD, H. M. 1959. Effect on albino rat testes of single and multiple hypoglycemic coma. In *Twenty-first International Congress of Physiological Sciences*, p. 174.
- MANDE, A. M. 1954. The sensitivity of adrenalectomized rats to gonadotrophins. *J. Endocrinol.*, **11**, 359.
- MANN, T., AND LUTWAK-MANN, C. 1951. Secretory function of male accessory organs of reproduction in mammals. *Physiol. Rev.*, **31**, 27.
- MANN, T., AND WALTON, A. 1953. Effect of underfeeding on genital functions of the bull. *J. Agric. Sci.*, **43**, 343.
- MASOOSH, M. 1952. Thyroid functions in relation to reproduction of mammals and birds. *Biol. Rev. Cambridge Phil. Soc.*, **27**, 281.
- MARRIEN, G. F., AND PARKES, A. S. 1929. The effect of anterior pituitary preparation administered during dietary anoestrus. *Proc. Roy. Soc. London, ser. B*, **105**, 248.
- MASIN, F. 1950. El efecto de la administracion de dosis elevadas de concentrados sobre la citologia del fluido vaginal de la rata. *Acta cient. venezolana*, **1**, 26.
- MASON, K. E. 1933. Differences in testis injury and repair after vitamin A deficiency, vitamin E deficiency, and inanition. *Am. J. Anat.*, **52**, 153.
- MASON, K. E. 1939. Relation of vitamins to sex glands. In *Sex and Internal Secretions*, 2nd ed., E. Allen, C. H. Danforth and E. A. Doisy, Eds., p. 1149. Baltimore: The Williams & Wilkins Company.
- MASON, K. E. 1941. Physiologic action of vitamin E and its homologues. *Vitamins & Hormones*, **2**, 107.
- MASON, K. E., AND MAUER, S. I. 1957. Reversible testis damage in vitamin E deficient hamster. *Anat. Rec.*, **127**, 329.
- MASON, K. E., AND WOLFE, J. M. 1930. The physiologic activity of the hypophysis of rats under various experimental conditions. *Anat. Rec.*, **45**, 232.
- MAYER, J., AND GOODARD, J. W. 1951. Effects of administration of gonadotrophic hormone on vitamin A deficient rats. *Proc. Soc. Exper. Biol. & Med.*, **76**, 149.
- MAYER, J., AND TRUANT, A. P. 1949. Effects of administration of testosterone on vitamin A-deficient rats. *Proc. Soc. Exper. Biol. & Med.*, **72**, 136.
- MEITES, J. 1952. Changes in nutritional requirements accompanying marked changes in hormone levels. *Metabolism*, **1**, 58.
- MEITES, J. 1953. Relation of nutrition to endocrine-reproductive functions. *Iowa State Coll. J. Sc.*, **28**, 19.
- MEITES, J., AND AGRAWALA, I. P. 1949. Effects of underfeeding on thiouracil action in rats and mice. *Endocrinology*, **45**, 148.
- MEITES, J., FENG, Y. S. L., AND WILWERTH, A. M. 1957. The effects of endocrine imbalances on vitamin requirements. *Am. J. Clin. Nutrition*, **5**, 381.
- MEITES, J., AND REED, J. O. 1949. Effects of restricted feed intake in intact and ovariectomized rats on pituitary lactogen and gonadotrophin. *Proc. Soc. Exper. Biol. & Med.*, **70**, 513.
- MENZE, W. 1941. Über dem Einfluss des Hungers auf die Keimdrüsen. *Endokrinologie*, **24**, 159.
- MIGON, C. J. 1952. Effect of cortisone on lipids of serum, liver and testes in intact and adrenalectomized rats. *Proc. Soc. Exper. Biol. & Med.*, **80**, 571.
- MILLER, S., RUTTINGER, V., AND MACEY, I. G. 1954. Urinary excretion of ten amino acids by women during the reproductive cycle. *J. Biol. Chem.*, **209**, 795.
- MOORE, C. R. 1939. Biology of the testis. In *Sex and Internal Secretions*, 2nd ed., E. Allen, C. H. Danforth and E. A. Doisy, Eds., p. 681. Baltimore: The Williams & Wilkins Company.
- MOORE, C. R. 1953. Adrenal cortical secretions in relation to the reproductive system of rats. *J. Clin. Endocrinol.*, **13**, 330.
- MOORE, C. R., AND SAMUELS, L. T. 1931. The action of testis hormone in correcting changes induced in the rat prostate and seminal ves-



- cles by vitamin B deficiency or partial inanition. *Am. J. Physiol.*, **96**, 278.
- MOORE, H., JESSOP, W. J. E., O'DONOVAN, D. K., BARRY, A. P., QUINN, B., AND DRURY, M. I. 1951. Cortisone in treatment of toxæmia of pregnancy; a study of eight cases. *Brit. M. J.*, **1**, 841.
- MOORE, M. 1948. Effect of alloxan diabetes on hyaluronidase level of the rat testes. *Proc. Soc. Exper. Biol. & Med.*, **69**, 391.
- MORGAN, A. F. 1951. The effect of vitamin deficiencies on adrenocortical function. *Vitamins & Hormones*, **9**, 161.
- MORRIS, H. P., DUNN, T. B., AND WAGNER, B. P. 1953. Influence of gonadotrophin on pyridoxine-deficient and diet-restricted female mice. *J. Nat. Cancer Inst.*, **14**, 493.
- MORRISON, S. D. 1956. The nitrogen balance of pregnant rats. *J. Physiol.*, **133**, 167.
- MORTON, J. H. 1958. Three obscure causes of female infertility. *Internat. Rec. Med.*, **171**, 63.
- MUKHERJEE, A. K., AND BANERJEE, S. 1951. Studies of histologic changes in experimental scurvy. *Anat. Rec.*, **120**, 907.
- MULINOS, M. G., AND POMERANTZ, L. 1940. Pseudohypophysectomy, a condition resembling hypophysectomy, produced by malnutrition. *J. Nutrition*, **19**, 493.
- MULINOS, M. G., AND POMERANTZ, L. 1941a. The reproductive organs in malnutrition; effects of chorionic gonadotrophin upon atrophic genitalia of underfed male rats. *Endocrinology*, **29**, 267.
- MULINOS, M. G., AND POMERANTZ, L. 1941b. Pituitary replacement therapy in pseudohypophysectomy; effects of pituitary implants upon organ weights of starved and underfed rats. *Endocrinology*, **29**, 558.
- NELSON, M. M., AND EVANS, H. M. 1953. Relation of dietary protein levels to reproduction in the rat. *J. Nutrition*, **51**, 71.
- NELSON, M. M., AND EVANS, H. M. 1954. Maintenance of pregnancy in the absence of dietary protein with estrone and progesterone. *Endocrinology*, **55**, 543.
- NELSON, M. M., AND EVANS, H. M. 1955. Maintenance of pregnancy in absence of dietary protein with progesterone. *Proc. Soc. Exper. Biol. & Med.*, **88**, 444.
- NELSON, M. M., AND EVANS, H. M. 1956. Failure of ovarian hormones to maintain pregnancy in rats deficient in pantothenic or pteroylglutamic acid. *Proc. Soc. Exper. Biol. & Med.*, **91**, 614.
- NELSON, M. M., LYONS, W. R., AND EVANS, H. M. 1951. Maintenance of pregnancy in pyridoxine-deficient rats when injected with estrone and progesterone. *Endocrinology*, **48**, 726.
- NELSON, M. M., LYONS, W. R., AND EVANS, H. M. 1953. Comparison of ovarian and pituitary hormone for maintenance of pregnancy in pyridoxine-deficient rats. *Endocrinology*, **52**, 585.
- NELSON, M. R., ARNRICH, L., AND MORGAN, A. F. 1957. Derangement of carbohydrate metabolism in riboflavin-deficient rat. *Fed. Proc.*, **16**, 394.
- NELSON, W. O. 1933. Studies on anterior hypophysis. III. Anterior hypophysis in vitamin E-deficient rats. *Anat. Rec.*, **56**, 211.
- NEWBERNE, P. M., AND O'DELL, B. L. 1958. Histopathology of hydrocephalus resulting from a deficiency of B<sub>12</sub>. *Proc. Soc. Exper. Biol. & Med.*, **97**, 62.
- NEWTON, W. H. 1952. Changes in the maternal organism during pregnancy. In *Marshall's Physiology of Reproduction*, p. 442. New York: Longmans, Green & Company.
- NIEMAN, C., AND KLEIN OBBINK, H. J. 1954. The biochemistry and pathology of hypervitaminosis A. *Vitamins & Hormones*, **12**, 69.
- NOALL, M. W., RIGGS, T. R., WALKER, L. M., AND CHRISTENSEN, H. N. 1957. Endocrine control of amino acid transfer. *Science*, **126**, 1002.
- NOUMURA, T. 1956. Effects of desoxycorticosterone acetate and cortisone on ovaries of mice in parabiosis with castrated males. *Jap. J. Zool.*, **12**, 57.
- ORLEY, R., PENCHARZ, R., AND LEPKOVSKY, S. 1950. Sex hormonal effects in incipient biotin deficiency. *Am. J. Physiol.*, **161**, 1.
- OVERBY, L. R., FROST, D. V., AND FREDRICKSON, R. L. 1959. The antihypertoxic factor of liver. II. Comparative activities of defatted liver residue and various fats. *J. Nutrition*, **68**, 251.
- PAN, S. Y., VAN DYKE, H. B., KAUNITZ, H., AND SLANETZ, C. A. 1949. Effect of vitamin E deficiency on amount of gonadotrophin in the anterior pituitary of rats. *Proc. Soc. Exper. Biol. & Med.*, **72**, 523.
- PANOS, T. C., AND FINERTY, J. C. 1953. Effects of a fat-free diet on growing female rats, with special reference to the endocrine system. *J. Nutrition*, **49**, 397.
- PANOS, T. C., AND FINERTY, J. C. 1954. Effects of a fat-free diet on growing male rats with special reference to the endocrine system. *J. Nutrition*, **54**, 315.
- PANOS, T. C., KLEIN, G. E., AND FINERTY, J. C. 1959. Effects of fat deficiency in pituitary-gonad relationships. *J. Nutrition*, **68**, 509.
- PAPPENHEIMER, A. M., AND SCHOGOLEFF, C. 1944. The testis in vitamin E-deficient guinea pigs. *Am. J. Path.*, **20**, 239.
- PARLOW, A. F. 1958. A rapid bioassay method for LH and factors stimulating LH secretion. *Fed. Proc.*, **17**, 402.
- PARRY, H. B., AND TAYLOR, W. H. 1956. Renal function in sheep during normal and toxæmic pregnancies. *J. Physiol.*, **131**, 383.
- PASCHKIS, K. E., AND CANTAROW, A. 1958. Pregnancy, tumor growth, and liver regeneration. *Cancer Res.*, **18**, 1060.
- PAZOS, R., JR., AND HUGGINS, C. 1945. Effect of androgen on the prostate in starvation. *Endocrinology*, **36**, 416.
- PEARSE, A. G. E., AND RINALDINI, L. M. 1950. Histochemical determination of gonadotrophin

- in the rat hypophysis. *Brit. J. Exper. Path.*, **31**, 510.
- PEARSON, P. B. 1936. Dietary protein in relation to the estrous cycle. *Proc. Am. Soc. Anim. Prod.*, **282**.
- PEARSON, P. B., HART, E. B., AND BOHSTEDT, G. 1937. The effect of the quality of protein on the estrous cycle. *J. Nutrition*, **14**, 329.
- PEORA, L. J., AND HIGHMAN, B. 1953. Organ weights and histology of chronically thiamine-deficient rats and their pair-fed controls. *J. Nutrition*, **51**, 219.
- PEDERSEN, J. 1952. Course of diabetes during pregnancy. *Acta endocrinol.*, **9**, 312.
- PEQUIGNOT, E. 1956. Studies on the actual nutrition of 55 pregnant women. *Bull. Inst. Nat. Hyg.*, **11**, 107.
- PERLOFF, W. H., LASCHE, E. M., NOBINE, J. H., SCHNEEBERG, N. G., AND VIELLARD, C. B. 1951. The starvation state and functional hypopituitarism. *J. A. M. A.*, **155**, 1307.
- PETERSON, R. R., WEBSTER, R. C., RAYNER, B., AND YOUNG, W. C. 1952. The thyroid and reproductive performance in the adult female guinea pig. *Endocrinology*, **51**, 501.
- PIKE, R. L., AND KIRKSEY, A. 1959. Some effects of isonicotinic acid hydrazine-induced vitamin B<sub>6</sub> deficiency in pregnant rats. *J. Nutrition*, **68**, 561.
- PIKE, R. L., SUDER, H. B., AND ROSS, M. L. 1951. The influence of protein and energy intakes upon nitrogen retention in the pregnant rat. *J. Nutrition*, **52**, 297.
- PLAGGE, J. C., MARASSO, F. J., AND ZIMMERMAN, H. J. 1958. Estrogen inhibition of nutritional fatty liver. *Metabolism*, **7**, 154.
- POMERANTZ, L., AND MULINOS, M. G. 1939. Pseudohypophysectomy produced by inanition (Abstr.). *Am. J. Physiol.*, **126**, P601.
- POMERANZE, J., PILIERO, S. J., MEDECI, P. T., AND PLACITA, A. 1959. Deficiency diets in young growing rats. *Proc. Soc. Exper. Biol. & Med.*, **100**, 207.
- POO, L. J., LEW, W., AND ADDIS, T. 1939. Protein metabolism of organs and tissues during pregnancy and lactation. *J. Biol. Chem.*, **128**, 69.
- POPOFF, J. S., AND OKULTSCHIEW, G. Z. 1936. Der Einfluss der Ernährung auf die Geschlechtsfunktion. *Ztschr. Zuchtung B.*, **1936**, 221.
- PUGSLEY, L. I. 1957. The biological assay of chorionic gonadotrophin and of the gonadotrophin of pregnant mare's serum using dietary anaestrous adult rats. *Canad. J. Biochem. & Physiol.*, **35**, 889.
- QUIMBY, F. H. 1948. Organ weights of rats receiving hormone supplements during recovery from chronic starvation. *Endocrinology*, **42**, 263.
- RALLI, W. P., AND DUMM, M. E. 1952. Nutritional fractions affecting survival in young adrenalectomized rats. *Endocrinology*, **51**, 135.
- RANNEY, R. E., AND DRILL, V. A. 1957. The ability of 17-ethyl-19-nortestosterone to block ethionine-induced fatty liver in rats. *Endocrinology*, **61**, 476.
- REECE, R. P. 1950. Effectiveness of estrogens in stimulating duct growth of the mammary glands of rats. *Proc. Soc. Exper. Biol. & Med.*, **73**, 284.
- REECE, R. P. 1959. The role of nutrition in mammary gland physiology. In *Reproductive Physiology and Protein Nutrition*, p. 23. New Brunswick: Rutgers University Press.
- REECE, R. P., TURNER, C. W., HATHAWAY, I. L., AND DAVIS, H. P. 1937. Lactogen content of pituitary glands from rats on vitamin deficient rations. *Proc. Soc. Exper. Biol. & Med.*, **37**, 293.
- REED, D. C., BROWNING, W. H., AND O'DONNELL, H. F. 1958. Male subfertility: treatment with liothyronine (cytomel). *J. Urol.*, **79**, 868.
- REID, J. T. 1949. Relationship of nutrition to fertility in animals. *J. Am. Vet. M. A.*, **114**, 158.
- RICE, E. G., AND BO, W. J. 1958. Effect of  $\beta$ -carotene and cortisone on vaginal epithelium of vitamin A deficient rats. *Proc. Soc. Exper. Biol. & Med.*, **98**, 877.
- RICHTER, K. M., AND WINTER, C. A. 1947. A quantitative study of the effect of hyperthyroidism on genital structure and function. *Am. J. Physiol.*, **150**, 95.
- RINALDINI, L. M. 1949. Effect of chronic inanition on the gonadotrophic content of the pituitary gland. *J. Endocrinol.*, **6**, 51.
- RIVERO, FONTAN, J., PASCHIKIS, K. E., WEST, E., AND CANTAROW, A. 1952. Influence of different dietary protein levels in starvation on the endocrine system of male and female rats. *Endocrinology*, **51**, 100.
- ROBSON, J. M., AND SHARAF, A. A. 1951. Interruption of pregnancy with ACTH and cortisone. *J. Physiol.*, **114**, 11p.
- ROSENTHAL, H. L., AND ALLISON, J. B. 1956. Effects of calorie intake on nitrogen balance and organ composition of adult rats. *Agric. & Food Chem.*, **4**, 792.
- ROSS, M. L., AND PIKE, R. L. 1956. The relationship of vitamin B<sub>6</sub> to serum protein and non-protein nitrogen in the rat during pregnancy. *J. Nutrition*, **60**, 211.
- ROWLANDS, I. W., AND SINGER, E. 1936. Gonadotrophic activity of the pituitaries of vitamin E-deficient rats. *J. Physiol.*, **86**, 323.
- RYABINA, Z. A. 1952. Effect of protein deficiency on structure and functional state of white rat ovaries. *Doklady Akad. Nauk S. S. R.*, **86**, 877.
- SALHANICK, H. A., HISAW, F. L., AND ZARROW, M. X. 1952. The action of estrogen and progesterone on the gonadotrophin content of the pituitary of the monkey (*Macaca mulatta*). *J. Clin. Endocrinol.*, **12**, 310.
- SALVENSEN, H. A. 1957. Endocrine organs and undernutrition: paradoxical behavior of the pancreas. *Acta endocrinol.*, **25**, 173.
- SAMUELS, L. T. 1948. *Nutrition and Hormones*. Springfield, Ill.: Charles C Thomas.

- SAMUELS, L. T. 1949. The metabolism of androgens by tissues. *Recent Progr. Hormone Res.*, **4**, 65.
- SAMUELS, L. T. 1953. Effect of protein and amino acids of the diet on the endocrine system. In *Protein Metabolism, Hormones and Growth*, p. 11. New Brunswick: Rutgers University Press.
- SAMUELS, L. T., REINECKE, R. M., AND PETERSON, W. E. 1941. Relation of nutrition to mammary growth after estradiol administration to hypophysectomized rats. *Proc. Soc. Exper. Biol. & Med.*, **46**, 379.
- SCHULTZE, M. O. 1955. Effects of malnutrition in early life on subsequent growth and reproduction of rat. *J. Nutrition*, **56**, 25.
- SCHULTZE, M. O. 1956. Reproduction of rats fed protein-free amino acid rations. *J. Nutrition*, **60**, 35.
- SCOTT, E. B. 1956. Histopathology of amino acid deficiencies. V. Isoleucine. *Proc. Soc. Exper. Biol. & Med.*, **92**, 134.
- SEGALOFF, A., AND SEGALOFF, A. 1944. The role of the vitamins of the B-complex in estrogen metabolism. *Endocrinology*, **34**, 346.
- SHERMAN, H. C., PEARSON, C. S., BAL, M. E. R., MCCARTHY, A., AND LANFORD, C. S. 1956. Influence of protein and calcium additions to already adequate diet. *Proc. Nat. Acad. Sc. U. S.*, **42**, 682.
- SHERMAN, W. C. 1941. The effect of certain fats and unsaturated fatty acids upon the utilization of carotene. *J. Nutrition*, **22**, 153.
- SHIPLEY, E. G., AND DANLEY, K. S. 1947. Pituitary and ovarian dysfunction in experimental diabetes. *Am. J. Physiol.*, **150**, 84.
- SHIPLEY, R. A., CHUDZIK, E. B., CURTISS, C., AND PRICE, J. W. 1953. Effect of lipotropic deficient diets and steroid hormones on the pregnant rat. *Metabolism*, **2**, 165.
- SIMS, F. H. 1951. Methionine and choline deficiency in the rat with special reference to the pregnant state. *Brit. J. Exper. Path.*, **32**, 481.
- SINDBEN, J. A., AND LONGWELL, B. B. 1949. Effect of alloxan diabetes on fertility and gestation in the rat. *Proc. Soc. Exper. Biol. & Med.*, **70**, 607.
- SKELTON, F. R. 1950. Some specific and non-specific effects of thiamine deficiency in the rat. *Proc. Soc. Exper. Biol. & Med.*, **73**, 516.
- SMITHBERG, M., AND RUNNER, M. N. 1957. Pregnancy induced in genetically sterile mice. *J. Hered.*, **48**, 97.
- SOUDERS, H. J., AND MORGAN, A. F. 1957. Weight and composition of organs during the reproductive cycle in the rat. *Am. J. Physiol.*, **191**, 1.
- SREBNIK, H. H., AND NELSON, M. M. 1957. Increased pituitary gonadotrophic content in protein deficient castrate rats. *Anat. Rec.*, **127**, 372.
- SREBNIK, H. H., NELSON, M. M., AND SIMPSON, M. E. 1958. Response of exogenous gonadotrophins in absence of dietary protein. *Proc. Soc. Exper. Biol. & Med.*, **99**, 57.
- STENGER-HAFFEN, K., AND WOLFF, E. 1957. L3-differentiation des organes sexuels cultivés en milieu synthétique. Rôle et mode d'action des hormones sexuelles. In *Proceedings Fourth International Congress of Nutrition*, p. 49.
- STEPHENS, D. J. 1941. Anorexia nervosa; endocrine factors in undernutrition. *J. Clin. Endocrinol.*, **1**, 257.
- STEPHENS, D. J., AND ALLEN, W. M. 1941. The effect of refeeding and of the administration of a pituitary extract on the ovaries of undernourished guinea pigs. *Endocrinology*, **23**, 580.
- SUTTON, T. S., AND BRIEF, B. J. 1939. Physiologic changes in the anterior hypophysis of vitamin A-deficient rats. *Endocrinology*, **25**, 302.
- SZEGO, C. M., AND BARNES, R. H. 1943. Dietary fatty livers in mice and sensitivity to exogenous estrogen. *Endocrinology*, **32**, 367.
- TALBERT, G. B., AND HAMILTON, J. B. 1955. The effect of reduced rate of growth on maturation of the male reproductive system of the albino rat. *Anat. Rec.*, **121**, 763.
- THIERSCH, J. B. 1954. Effect of certain 2,4-diaminopyrimidine antagonists of folic acid on pregnancy and rat fetus. *Proc. Soc. Exper. Biol. & Med.*, **87**, 571.
- TRENTIN, J. J., AND TURNER, C. W. 1941. Quantitative study of the effect of inanition on responsiveness of the mammary gland to estrogen. *Endocrinology*, **29**, 984.
- TUCHMANN-DUPLISSIS, H., AND ASCHKENASY-LELU, P. 1947. Modifications histologiques de l'ovaire et du tractus génital de la rate adulte soumise au régime hyperprotidique. *Compt. rend. Soc. biol.*, **141**, 689.
- TUCHMANN-DUPLISSIS, H., AND ASCHKENASY-LELU, P. 1948. Basophilie et augmentation du pouvoir gonadotrope de l'hypophyse de la rate en hyperprotéose. *Compt. rend. Soc. biol.*, **142**, 472.
- ULLREY, D. E., BECKER, D. E., TERRILL, S. W., AND NOTZOLD, R. A. 1955. Dietary levels of pantothenic acid and reproductive performance of female swine. *J. Nutrition*, **57**, 401.
- UMBERGER, E. J., AND GASS, G. H. 1958. The effect of dietary fat on the uterine weight response of immature mice to oral stilbesterol. *Endocrinology*, **63**, 801.
- VANDERLINDE, R. E., AND WESTERFIELD, W. W. 1950. The inactivation of estrone by rats in relation to dietary effects on the liver. *Endocrinology*, **47**, 265.
- VAN PILSUM, J. F., SPEYER, J. F., AND SAMUELS, L. T. 1957. Essential amino acid deficiency and enzyme activity. *Arch. Biochem.*, **68**, 42.
- VASINGTON, F. D., PARKER, A., HEADLEY, W., AND VANDERLINDE, R. E. 1958. Relationship of low protein diet and ascorbic acid in estrogen inactivation by liver. *Endocrinology*, **62**, 557.
- VELARDO, J. T., AND HISAW, F. L. 1953. Inhibitory effects of aminopterin on decidual development. *Am. J. Physiol.*, **172**, 535.
- VISSCHER, M. B., KING, J. T., AND LEE, Y. C. P. 1952. Further studies on influence of age and

- diet upon reproductive senescence in strain A female mice. *Am. J. Physiol.*, **170**, 72.
- VOLLMEER, E. P. 1943. Relation of hypopituitarism and starvation. *Nature*, London, **151**, 698.
- WALYAS, O. 1952. Effect of estrogens on the glycogen content of the rat uterus. *Acta endocrinol.*, **10**, 175.
- WALKER, D. G., AND WIRTSCHAFTER, Z. T. 1956. Estrogenic inhibition of fetal reabsorption in lathyrism. *J. Nutrition*, **58**, 161.
- WARD, L. W., SLOCUMB, C. H., POLLEY, H. F., LOWMAN, E., AND HENCH, P. S. 1951. Clinical effects of cortisone administered orally to patients with rheumatoid arthritis. *Proc. Staff Meet., Mayo Clin.*, **26**, 361.
- WARKANY, J., AND SCHRAFFENBERGER, E. 1944. Congenital malformations of the eyes induced in rats by maternal vitamin A deficiency. *Proc. Soc. Exper. Biol. & Med.*, **57**, 49.
- WEATHERBY, E. J., AND REECE, R. P. 1941. Effect of a high- and low-protein ration on the gonadotrophic content of male rat pituitaries. *J. Dairy Sc.*, **24**, 508.
- WEIR, D. R., AND LEUCHTENBERGER, C. 1957. Low sperm desoxythymine nucleic acid as possible cause for otherwise unexplained human infertility. *Fertil. & Steril.*, **8**, 373.
- WEGNER, S. C. 1939. Failure of gonadotrophic function of the rat hypophysis during chronic inanition. *Proc. Soc. Exper. Biol. & Med.*, **41**, 101.
- WHITE, F. R., AND WHITE, J. 1942. Effect of a low cystine diet on the growth of various strains of mice. *J. Nat. Cancer Inst.*, **2**, 449.
- WHITMAN, C. H., AND BOGART, R. 1956. Reproductive capacity in female rats as affected by kinds of carbohydrate in the ration. *J. Agric. Res.*, **53**, 527.
- WILSON, J. G., ROTH, C. B., AND WARKANY, J. 1953. An analysis of the syndrome of malformations induced by maternal vitamin A deficiency. Effects of restoration of vitamin A at various times during gestation. *Am. J. Anat.*, **92**, 189.
- WOLF, R. C., AND LEATHEM, J. H. 1955. Hormonal and nutritional influences on the biochemical composition of the rat testis. *Endocrinology*, **57**, 286.
- WOOLLAM, D. H. M., AND MILLEN, J. W. 1957. The effect of cortisone on the incidence of cleft palate in the offspring of female rats subjected to hypervitaminosis A. In *Proceedings Fourth International Congress of Nutrition*, p. 52.
- WOOTEN, E., NELSON, M. M., SIMPSON, M. E., AND EVANS, H. M. 1955. Effect of pyridoxine deficiency on the gonadotrophic content of the anterior pituitary of the rat. *Endocrinology*, **56**, 59.
- WOOTEN, E., NELSON, M. M., SIMPSON, M. E., AND EVANS, H. M. 1958. Response of vitamin B<sub>6</sub>-deficient rats to hypophysal follicle-stimulating and interstitial cell-stimulating hormones. *Endocrinology*, **63**, 860.
- YAMAMOTO, R. S., AND CHOW, B. F. 1950. Role of dietary proteins in development of sex organs of young rats under stimulus of a gonadotrophin. *Fed. Proc.*, **9**, 250.
- YOUNG, W. C., RAYNER, B., PETERSON, R. R., AND BROWN, M. M. 1952. The thyroid and reproductive performance in the adult male guinea pig. *Endocrinology*, **51**, 12.
- ZIMMER, R., WEILL, J., AND DUBOIS, H. 1944. Nutritional situation in camps of the occupied zone of France in 1941 and 1942 and its consequence. *New England J. Med.*, **230**, 303.
- ZONDER, B. 1934. Fate of follicular hormone in the living body. *Lancet*, **227**, 356.
- ZUBRAN, S., AND GOMEZ-MONT, F. 1953. Endocrine disturbances in chronic human malnutrition. *Vitamins & Hormones*, **11**, 97.
- ZUCKERMAN, S. 1953. The adrenogenital relationship. The suprarenal cortex. In *Proceedings Fifth Symposium Colston Research Society*, p. 69. New York: Academic Press, Inc.







