

6.516.6
1468

U. of I.

DEPARTMENT of ARCHITECTURE

SHADES and SHADOWS

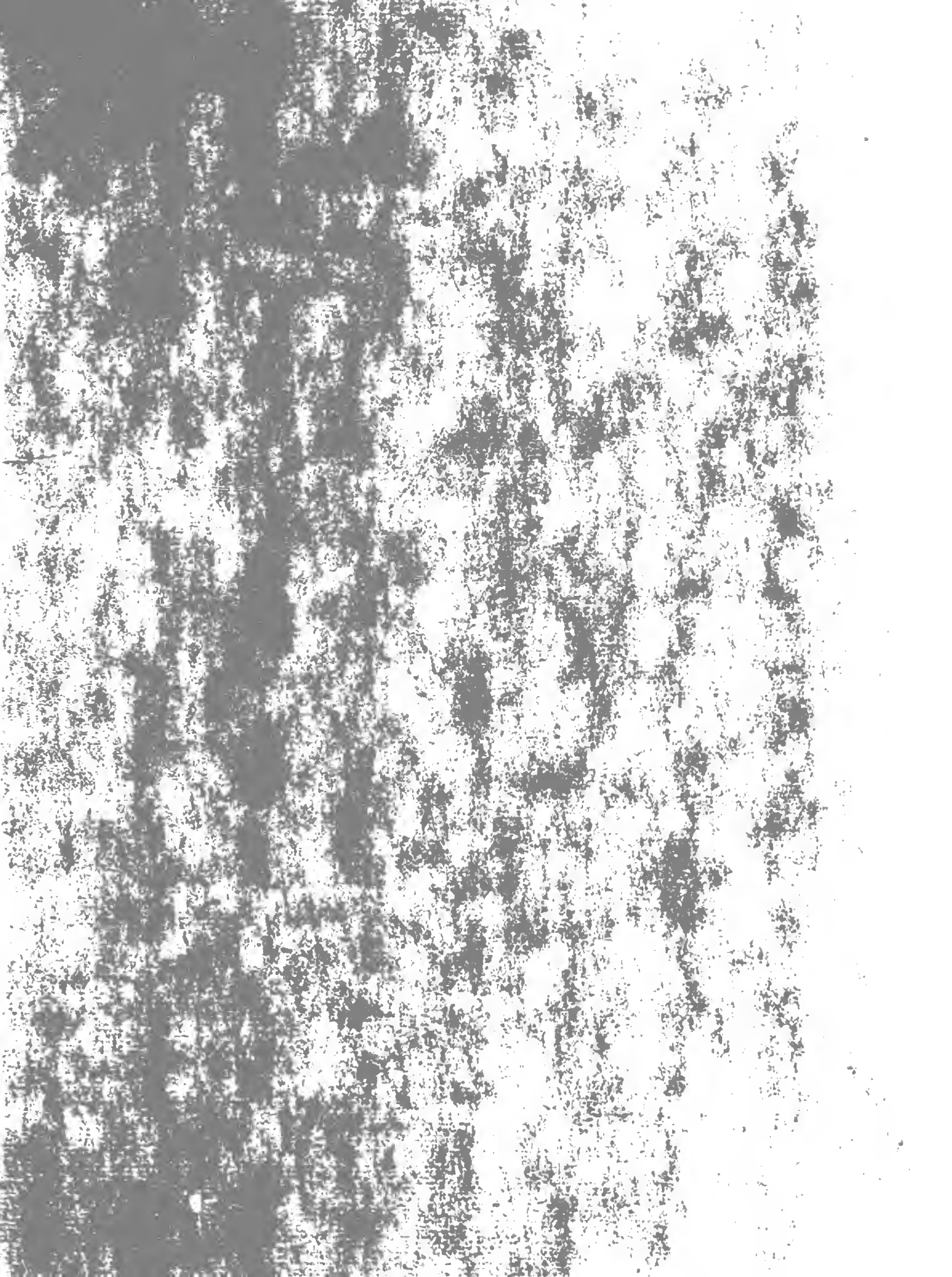

Digitized by the Internet Archive
in 2011 with funding from
University of Illinois Urbana-Champaign



SHADES AND SHADOWS

Notes Arranged For

The Department of Architecture

UNIVERSITY OF ILLINOIS--

* * *

Mimeographed by

Student Supply Store
Champaign, Ill.

11

SHADES AND SHADOWS

NOTES ARRANGED BY RALPH FANNING

1. INTRODUCTION:

Objects are visible to the eye owing to the reflection from their surface of rays of light. These reflected rays strike upon the retina of the eye and give the sensation of sight. The greatest source of light is the sun, and rays from it strike all bodies on the earth at various angles. If the angles of impact of all the rays striking on the surface be the same, the surface appears flat, technically "plane". If the angles of impact are different then the surface appears "curved".

Since therefore, the pleasant or unpleasant effect of any object will depend upon the producing of an effect of pleasing or unpleasing lighting upon the eye, it becomes of primary importance that the students of those branches of art that deal with objects in the round, with objects subject for their effect upon the play of light and shade upon their surface, namely, Architecture and Sculpture, be thoroughly familiar with the phenomena of light and shade.

In addition to this it is essential that he who conceives an idea must be able to express that idea forcibly and convincingly to others, else his idea becomes of no importance. The painter expresses an idea in one way, the writer in another, the sculptor in another, the architect in still another. The Sculptor works out his idea in clay, then plaster, then in stone or in bronze; the architect has certain conditions set before him; he works out the idea in the drafting room and working under his direction, the builder executes that idea in permanent materials of wood, brick, and stone.

A building does not consist merely of the lines by which it is represented in geometrical drawing, but of masses and these are better and more quickly represented by tints than by mere line drawing and in order that the final results may be that pleasing creation that distinguishes the thing of art from that of pure utility--that make of it architecture--the architect must be thoroughly familiar with those general phenomena which will make of his creation a thing of beauty and must be able to represent those phenomena on drawings.

In order that a representation of light and shade may be made upon geometrical drawings, the architect brings into use an application of certain principles of descriptive geometry, using that science, however, not as a means alone, but as a means toward an end, and basing the general underlying principles of the application upon a careful observance of natural phenomena--adopting convenient conventions--never violating the fundamental

NOTES ASSIGNED BY WILLIAM PATRICK
PHYSICS AND CHEMISTRY

DATE: _____

When a light ray strikes a surface, it is either reflected or refracted. The angle of incidence is the angle between the incident ray and the normal to the surface. The angle of reflection is the angle between the reflected ray and the normal. The angle of refraction is the angle between the refracted ray and the normal. The normal is a line perpendicular to the surface at the point of incidence.

Light travels in straight lines. This can be demonstrated by the experiment of the pinholes. Light from a distant star passes through two small holes in a screen and forms a pattern of light and dark fringes on a screen behind it.

The speed of light is very fast. It is about 300,000,000 meters per second in a vacuum. The speed of light in air is slightly less than in a vacuum.

Light is a form of energy. It can be converted into other forms of energy. For example, light can be converted into heat energy when it strikes a black surface. Light can also be converted into electrical energy in a solar cell.

The electromagnetic spectrum consists of radio waves, microwaves, infrared, visible light, ultraviolet, X-rays, and gamma rays. All these waves travel at the same speed in a vacuum, which is the speed of light.

Light waves are transverse waves. The electric and magnetic fields oscillate perpendicular to each other and to the direction of propagation of the wave.

Light waves can be polarized. This means that the electric field oscillates in only one plane. Polarization can be achieved by reflection, scattering, or absorption.

SHADES AND SHADOWS

principles of natural phenomena.

2. LIGHT RAYS:

The rays of light which are dealt with in reference to any one body are first-direct or incident rays, second-tangential rays, -third-lateral rays. Direct rays impinge directly upon the body. Tangential rays are those tangent to its surface. Lateral rays do not strike the surface, but go on to illuminate bodies beyond. Naturally, in the study of Shades and Shadows, direct and tangential rays are those of importance. Fig. 1

3. SHADE AND SHADOWS:

If rays of light are excluded from certain portions of a surface by the shape of that surface itself, then the darkened portion is said to be in shade; if the surface, by projection beyond or position between the source of light and another surface, exclude light from any portion of the second surface, then the first one is said to "cast shadow over the second". Shadows reveal by their extent the relative position of as well as the shape of surfaces. Shade reveals merely the shape of separate surfaces.

4. REASONS FOR ASSUMPTION OF CERTAIN CONVENTIONS.

Any object placed in a fixed position on the earth, as is of course every building, will be subject to a continual change of lighting, to a continually changing play of light, shade and shadow. If on the geometrical or line drawing of an element architectural, each separate artist were to assume a direction for the rays of light that are presumed to illuminate an object--for naturally an assumption of directions of light is prerequisite to the working out of shades and shadows geometrically--then to each drawing would have to be added a statement of the assumptions made. The assumption of certain directions of the rays would be cause of great difficulties in the geometrical solution and a general confusion would result, though each distinct method or means would itself be correct. Since the finished result of the artist's efforts must be easily and clearly readable by those who do not understand the methods used in achieving the result set before them; since the working out of shadows is in any event a long and complicated process, and since, therefore, the adoption of any conventions tending to make for the draftsman greater ease of working, are of prime importance, and for these reasons solely

MEMORANDUM FOR THE RECORD

DATE: 10/14/54

10

MEMORANDUM FOR THE RECORD
SUBJECT: [Illegible]

[Illegible text]

RECOMMENDATION

[Illegible text]

[Illegible text]

ADMINISTRATIVE INFORMATION

[Illegible text]

[Illegible text]

SHADES AND SHADOWS

certain conventions as to direction of light have been universally adopted. The student, however, must not come to believe that the adoption for sake of convenience of particular conventions affect in any way the general principles underlying the Study of Shades and Shadows.

5. THE RAY AT 45%

In the study, therefore, of Shades and Shadows, the sun is assumed to be the source of light, and the rays assumed to take a downward direction, and to the right parallel to the diagonal of a cube (Fig. 2). The angle which the ray makes with its own projection is, therefore, $35^{\circ} 15' 52''$, and is known usually as the angle ϕ or the "true angle of the ray".

The projections of this one ray are three, and each projection naturally makes an angle of 45% with the horizontal, and since they originate at infinity--the sun--the projections of all rays in any particular plane are parallel. (Fig.3) Expressed architecturally, there is one ray with a front elevation, a side elevation and a plan as can be readily understood. The use of the ray in this particular direction, gives not only ease of construction, but also ease of interpretation of projections of surfaces on beyond the other, for naturally the width of the shadow cast by one plane surface over another will be exactly equal to the projection of the first surface in front of the second. Having established a definite basis for study there can now be discussed the various procedures necessary for the actual finding of Shades and Shadows under any given condition. To the study the architectural student must bring more than a mere knowledge of the processes of descriptive geometry. He must bring a sense of analysis and thoughtfulness that will enable him to discover in each problem those particular elements that are necessary for the rapid solution of the problem, but he must above all else cultivate a knowledge of the general shapes of actual Shades and Shadows and a common sense way of looking at any problem presented.

By a mere application of principles of descriptive geometry the finding of the precise piercing point of a line on a surface--any profile in shades and shadows can be solved, but since rapidity of thought and action as well as accuracy of result are the prime requisites of the architectural draftsman every effort must be made to learn the shortest and the easiest methods of achieving a given result. Analysis and acquired experience, thoughtfulness, imagination, observation of natural phenomena, these all will give rapidity and accuracy.

THE FINDING ON GEOMETRICAL DRAWINGS
OF SHADES AND SHADOWS
BY GEOMETRICAL MEANS

6. DEFINITIONS.

"A plane of Rays" is a plane which may be considered as made up of the rays passing through adjacent points of a straight line. (Fig. 4)

"Point of loss"-The point of intersection of a shadow with a shade line, or of a shadow or shade line with the line of division between a lighted and unlighted surface. (Fig. 5)

"Invisible shadows" or shadows in space"---that portion of space from which light is excluded by a body in direct light. (Fig. 6)

7. METHODS OF CONSTRUCTION.

The finding of shadows comprises two distinct operations, They are in order of construction:

1. The finding on the object itself of the line which separates the lighted part from that shaded part, known in consequence as the separation or separatrix or "shade line".
2. The finding of the outlines of the shadows cast by the object on a foreign surface, that surface being usually in the horizontal or vertical plane, known as the "shadow".

Since it has been assumed that the light rays fall in a definite position oblique to the vertical and horizontal plane of the projection and since architectural details are made up for the most part of regular surfaces, either planes at right angles to each other and parallel to or at right angles to the general surfaces of revolution whose elements are parallel or perpendicular to the same plane, when it is evident that in general the shadow of any object over another object in an oblique projection of the first object, and that, as can be readily seen, the outline of the first shadow is the shadow of the shade line of the object casting the shadow.

MEMORANDUM FOR THE RECORD

DATE: 10/15/54

TO: SAC, NEW YORK

FROM: SA [Name], NEW YORK

RE: [Subject]

[Faded typed text, likely the main body of the memorandum]

10/15/54

10/15/54

[Faded typed text, possibly a signature block or specific details]

[Faded typed text]

[Faded typed text]

[Faded typed text]

SHADES AND SHADOWS

8. THE SHADOWS OF POINTS.

The shadow of a point on any surface is found by passing a ray (straight line) through that point and finding where that ray pierces the surface. The point of piercing must necessarily be at the shadow of the point. (Fig. 7)

9. THE SHADOW OF LINES.

A straight line is by definition made up of a number of points. So that the passing of separate rays through each of the points would make a plane of rays, the intersection of which plane with the surfaces in question would give the line of shadow of the line considered. The length of the shadow would be determined by the shadows of the two points at the ends of the line or by the limits of the surfaces on which the shadow falls (Fig. 8).

10. THE SHADOWS OF SURFACES.

Since a surface is limited by lines, the shadow of a surface can evidently be found by finding the shadows of boundary lines of that surface.

11. THE SHADOWS OF SOLIDS.

a) Polyhedra.

These solids are bounded by portions of intersecting planes. The lines of demarcation between light and shade will naturally be along lines of intersection. The outlines of the shadows of a polyhedron will be determined by finding the shadows of those lines of intersection that divide the lighted from the unlighted portion of the polyhedra (Fig. 9).

b) Surfaces of Revolution.

The shade lines on surfaces of revolution are formed by rays tangent to the surfaces. The outline of the shadow will evidently depend upon the finding of the shadow of that line of tangency. (Fig. 10).

1944

1944

of the... (faint text)

1944

... (faint text)

1944

... (faint text)

1944

1944

... (faint text)

1944

... (faint text)

SHADES AND SHADOWS

12. THE GENERAL PROBLEM

From the preceding discussions it should be evident that the general problem involved is that of "representing the rays which pass through points in the shade line of an object and finding the points at which these rays strike another object. Generally speaking, this is not a difficult problem in descriptive geometry, and is one quite within the power of an architectural draftsman of a little experience, if he will keep clearly in mind the nature of the problem he is to solve. "He is apt to entangle himself in trying to remember rules and methods by which to reach a solution", (McGoodwin). Statement of certain more or less evident corollaries of preceding discussion.

A thorough understanding of the general corollaries stated below will be of inestimable benefit in quick and ready analysis of problems.

1. All straight lines and planes may be considered as being of indefinite extent. Parts not of such lines and planes lying beyond parts having actual existence in cases considered will be termed "imaginary". (Fig. 11).
2. (a) A point which is not in light cannot cast a real shadow.
 - (b) Every real shadow line must cast a real shadow and this real shadow cannot lie within another real shadow. Most of the blunders in casting shadows are due to a neglect or misunderstanding of these two statements. For instance, in Fig. 12 it is evident that point "a" cannot cast a shadow on the wall.
3. (a) The shadow of a straight line on a plane may be determined by the shadow of any two of its points on the plane. Naturally the shadows of the points at the ends of the line are the ones most advantageous to find.
 - (b) The shadows of any line on any surface may be determined by finding the shadows of adjacent points of the lines. As could be expected, this method is a very cumbersome one, and such shadows will be, wherever possible, found by less lengthy processes.

800

THE
STATE
OF
NEW YORK
IN SENATE
January 12, 1910.

REPORT
OF THE
COMMISSIONERS OF THE
LAND OFFICE

AND
OF THE
SURVEYORS GENERAL

FOR THE YEAR 1909

ALBANY: J.B. WOODCOCK, PRINTER, 1910.

The

REPORT

OF THE

COMMISSIONERS OF THE LAND OFFICE

AND OF THE SURVEYORS GENERAL

(1910)

FOR THE YEAR 1909

ALBANY: J.B. WOODCOCK, PRINTER, 1910.

(1910)

1910

1910

SHADES AND SHADOWS

13. THE GENERAL METHOD.

Sought for results may be achieved by cumbersome or by easy methods. So in the finding of shades and shadows on architectural drawings, certain methods have been found to give results easily and accurately. Those general methods found to be the most applicable are:

- 1) The method of oblique projections.
- 2) The method of circumscribing surfaces.
- 3) The method of auxiliary shadows.
- 4) The slicing method.

Each separate method will be discussed in detail in its proper sequence, and with its proper applications. All of the methods or but one method may be conveniently used in the casting of shadows on any one object. The use of a little common sense and visualizing faculty are essential if the student is to do any particular problem accurately and quickly.

14. THE METHOD OF OBLIQUE PROJECTION.

The method of oblique projection consists simply in drawing on the projections of the object the forty-five degree line representing the rays tangent to an object or passing through its shade line and then in finding the points where the rays strike any other object involved in the problem, these points of intersection giving the outline of the shadow.

This method is simple and direct, but naturally can be used only when the plan or side elevation can be represented by a line. Otherwise it is impossible to find directly points at which rays strike the given surface. For example, in plan the surface of a cylinder with vertical elements can be represented by a circle but the surface of a torus, scotia, or cone cannot. Hence in the latter cases some method other than that of direct projection must be used if shades or shadows are to be found on these surfaces. Theoretically this method requires the finding of the shadows of all points in a line, but practically, under the assumption made in this study--namely; rays of fixed direction parallel with each other--the shadows of certain points and lines on certain surfaces in certain portions will be always the same. They may be stated as follows:

- 1) The elevation of the shadow of a point on a vertical plane will always lie on a forty-five degree line to the right of the elevation of the point in front of the plane. (Fig. 13).

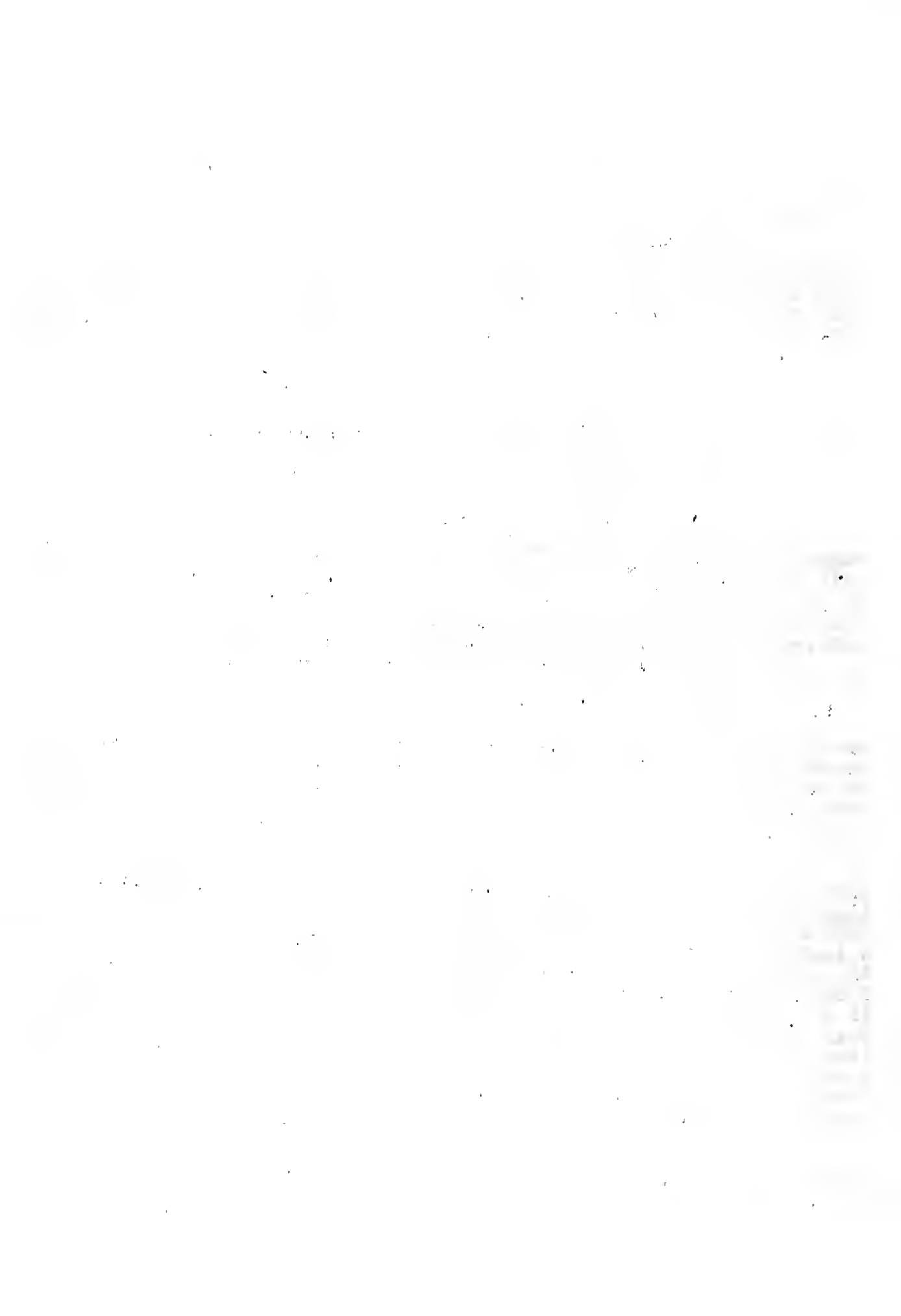

SHADES AND SHADOWS

2) The shadow on a given plane of any line which is parallel to that plane is a line equal and parallel to the given line and lies to the right of the line a distance equal to the distance of the line in front of the plane. (Fig. 14).

3) The shadows of parallel lines in any plane will be parallel.

4) The shadow of a line perpendicular to an elevation plane will in front elevation be always a forty-five degree line no matter what be the form or position of the objects receiving the shadow. The shadow of a line being formed by the intersection of a plane of rays, through the line with the surface considered, in this particular case, will coincide, of course, with the elevation of the plane of rays this plane will, therefore, be itself perpendicular to the surface receiving the shadow and will appear in elevation as a forty-five degree line. (Fig. 15).

5) The shadow in plane of line perpendicular to the plan plane should be a forty-five degree line. The reasoning given in (4) should be sufficient to make the point clear. (Fig. 16).

6) The shadow of a vertical line on an inclined plane whose horizontal lines are parallel to the elevation plane is an inclined plane whose slope is equal to that of the given plane. The most frequent application to architectural problems is found in shadows of dormers and chimneys on roofs. (Fig. 17).

7) The shadow of a vertical line on a series of horizontal mouldings is equal in front elevation to the profile of the right section of the mouldings. (Fig. 18). The shadow line of course moves to the right as the contour recedes. This shadow of such frequent occurrence in architectural problems is too often drawn incorrectly

8) The shadows of horizontal planes either parallel or perpendicular to the elevation plane, on a vertical plane receding diagonally to the left at an angle of forty-five degrees--are of the parallel lines forty-five degree lines, sloping downward and to the left, and of the perpendicular lines forty-five degree lines sloping downward and to the right. (Fig. 19). These shadows are often used in finding of auxiliary shadows.

Faint, illegible text in the upper section of the page, possibly a header or introductory paragraph.

Main body of faint, illegible text in the middle section of the page.

Faint, illegible text in the lower section of the page, possibly a footer or concluding paragraph.

SHADES AND SHADOWS

9) The shade line on a curved surface whose elements are horizontal or vertical straight lines, is found by drawing the elevation of a ray tangent to the profile of the surface. (Fig. 20). Evidently the shadow cast over such a surface by a straight line which is parallel to the elements of the surface can be found as shown. (Fig. 21).

With the knowledge, therefore, of the definite positions that the shadows of these lines which form boundary lines are to practically all surfaces appearing in architectural work take, the finding of shadows of even the most complicated surfaces becomes comparatively easy. Often the determination of the shadow of a single point will suffice for the determination of an entire group of shadows. An attempt must always be made to use as little as possible either plan or side elevation in determining shadows-- for they are often in architectural work at different scale from the front elevations, and if used to a large extent would have to be redrawn--a lengthy and entirely uncalled for proceeding.

SECRET

TO: [illegible]
FROM: [illegible]
SUBJECT: [illegible]

[The following text is extremely faint and largely illegible due to low contrast and blurring. It appears to be a memorandum or report containing several paragraphs of text, possibly including a subject line, a recipient list, and a body of text with various headings and sub-sections.]

SHADES AND SHADOWS
Nomenclature

For the purpose of clearness in reading of diagrams given, the following nomenclature has been adopted:

R - Ray of light in space at Conventional Angle.

R₁ - Front Elevation of Ray.

R₂ - Side elevation of Ray.

R₃ - Plan of Ray.

ϕ - True angle of Ray.

V - Vertical plane of projection or Front Elevation Plane

P - Profile or Side Elevation Plane.

H - Horizontal or plan plane.

X - Any other plane.

Let A Any point in space.

Then A₁ - Any point in front elevation.

A₂ - Same point in plan.

A₃ - Same point in side elevation.

Let. A_{1s} - Front elevation of shadow of point A.

A_{2s} - Plane of shadow of point A.

A_{3s} - Side elevation of shadow of point A.

GL - Ground Line-Line of intersection of V Plane and H plane.

NOTE: In lettering of all problems plates this nomenclature is to be followed.

The Architectural terms, front elevation (or usually Elevation), Side Elevation, and Plan, are to be used in preference to the terms V Projection, P projection, and H projection.

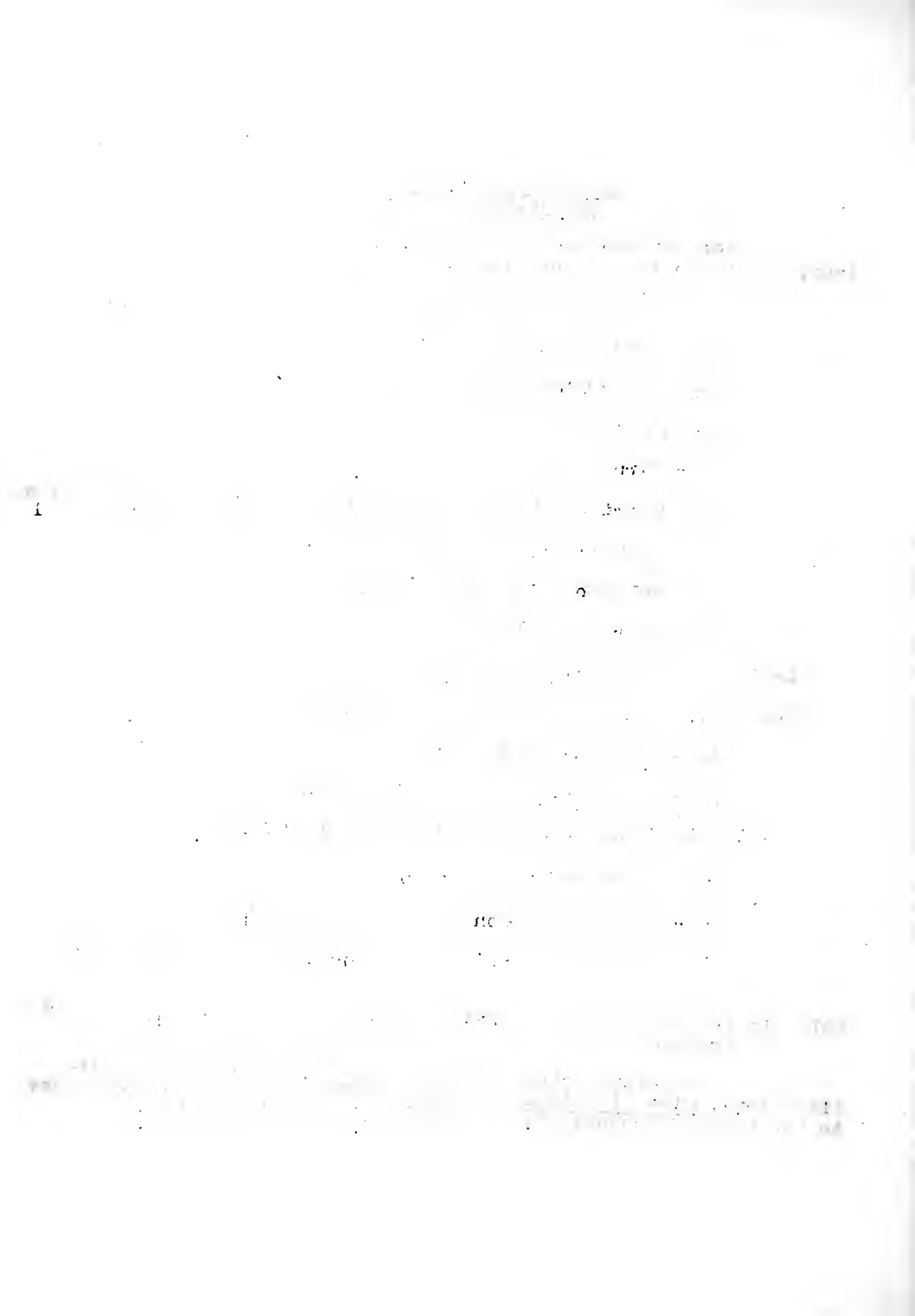

THE SHADOWS OF CIRCLES.

15. SHADOWS OF CIRCLES IN PLANES PARALLEL TO PLANE RECEIVING SHADOW.

It is quite evident that the shadow line of, for instance, a circular flat disk on a plane will be formed by the intersection of a cylinder of rays with the plane in question, and that the intersection of the cylinder will be a circle or an ellipse depending upon whether the disk were in a plane parallel to the given plane or in a plane at an angle with the given plane. (Fig. 22). It is also evident that in the first instance, the shadow line will be a circle of exactly the same radius as the disk casting the shadow, and that, therefore, the finding of the shadow of the center of the circle will be sufficient to determine the complete shadow. The arch is the common architectural form in which circles occur in such a position.

16. SHADOWS ON VERTICAL AND HORIZONTAL PLANES.

When the shadow line is an ellipse, by methods of direct projection from plan or side elevation as auxiliaries can be found a number of points of shadows of the circumference of the circle. Usually circular forms occur in architectural work in planes perpendicular to the vertical plane of projection and parallel to the horizontal, or in planes perpendicular to both planes of projection, and the shadow of such circles are usually cast on a vertical or elevation plane, though sometimes on a horizontal or plan plane. Since the center of the circle is a point, it is quite easy to determine its shadow, which determines naturally the center of the ellipse shadow. The major and minor axes of the ellipse of shadow are then determined.

The architect must, of course, determine if possible by methods of reasoning, those shadow points that will be of greatest importance, and through them must construct the ellipse of shadow. The simplest and most accurate method of determination is as follows. (Fig. 23).

The shadows of the circumscribed and the inscribed squares are first found, using the already found shadow of the center of the circle as a point for symmetrical construction. The shadows of the median and diagonal lines are easily found. The points at which the ellipse of shadow crosses the diagonals is found as shown in the figures. The tangents, which of course are parallel to the diagonals, are usually drawn to serve as a guide in freehand construction of the ellipse of shadow. Since the circle is a continuous curve, if through any inaccuracy of construction points of shadow found do not give continuous curve, then these points must be disregarded and the curve drawn through the greatest number that lie on a continuous curve.

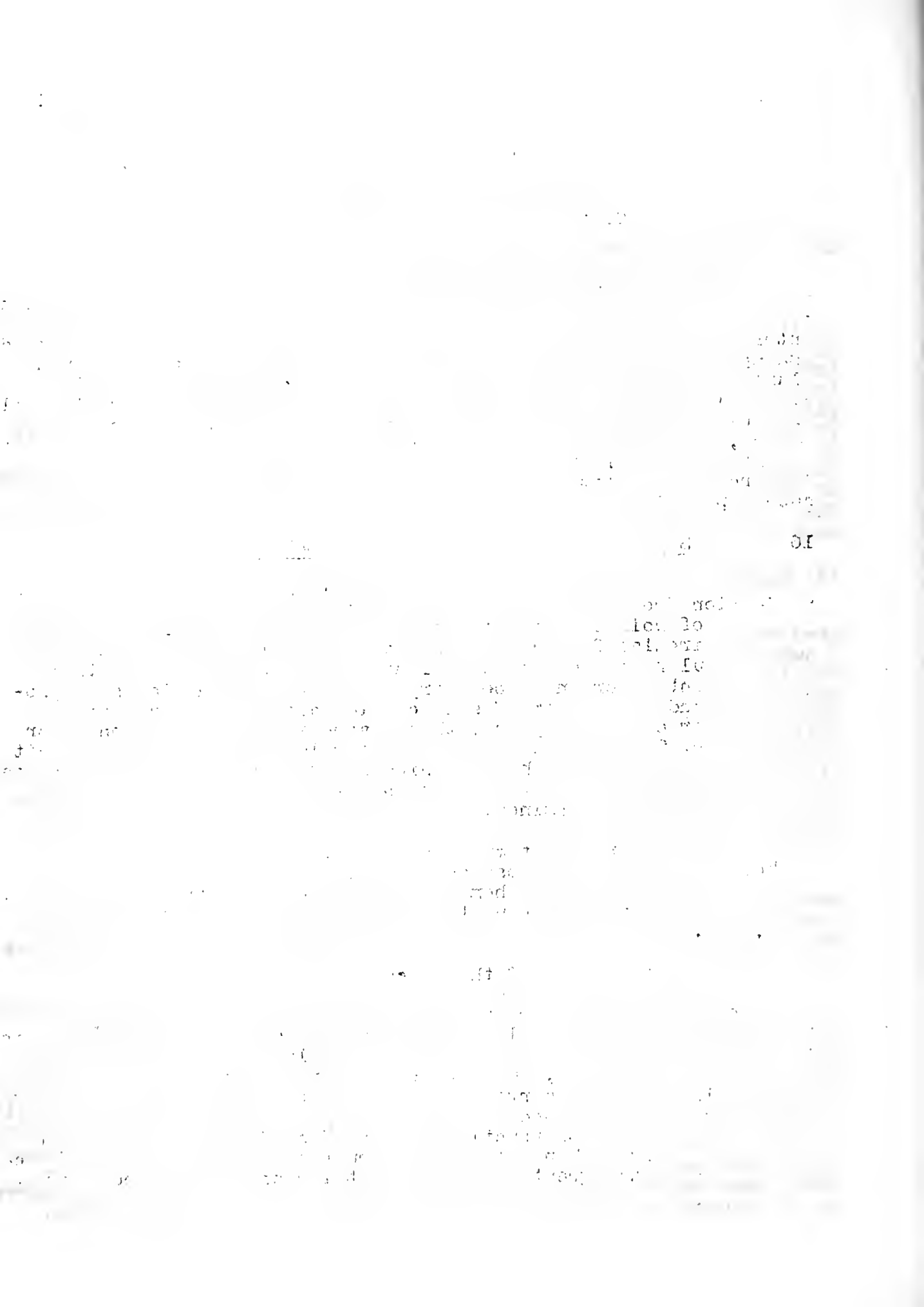

SHADES AND SHADOWS.17. SHADOWS ON INCLINED PLANES.

The same methods of reasoning as used for shadows of circles on vertical and horizontal planes give the construction of the shadow on an inclined plane, as shown in Fig. 24.

18. SHADOWS ON 45° AUXILIARY PLANE.

The shadow on a vertical plane at 45 degrees passing through its center, of a circle in a horizontal plane perpendicular to the elevation plane is a circle (Fig. 25).

19. CONCLUSION.

It must above all else be remembered that the shadow of any circle must, of course, be completely within the shadow of the circumscribed square and will be tangent to that shadow at points where the original circle is tangent to the circumscribed square, Time honored blunders in the casting of the shadows of circles may be almost entirely avoided by the accurate finding of the shadow of the circumscribed square even though the inscribed square is not found.

20. THE SHADES ON AND SHADOWS OF SURFACES OF REVOLUTION.

Surfaces of revolution are created by revolving lines straight or curved or both about a fixed axis or series of axes. In the forms commonly met with in architectural objects, the surfaces of revolution are generally either vertical or horizontal, so that the shapes created are more simple to deal with than those created when the axes are inclined. The study, therefore, will be confined to right cylinders, cones, spheres, tori and spheroids. The shades on and shadows of certain of these surfaces can easily be found by an application of some one or all of the methods mentioned at the beginning of the discussion.

21. THE SHADES ON AN UPRIGHT CYLINDER. (Fig. 26).

It is quite evident that the surface of an upright cylinder can be represented in plan by a circle, and the surface of a horizontal cylinder in side elevation by a circle. Hence the method of oblique projection can be applied in the finding of the shades and the shadows. The lines of shade on the cylinder will evidently be determined by two planes of rays tangent to the surface. They will come tangent along a vertical or horizontal element of the cylinder and can be represented in plan or side elevation as the case may be by lines tangent to the plan or side elevation of the line representing the surface of the cylinder. From the points of tangency thus determined are secured the lines of shades. One line of shade is of course invisible in the front elevation. The other is a little less than $1/6$ of the width of the elevation of the cylinder to the left of the right profile of the cylinder. This proportion is a convenient one to remember.

22. THE SHADOWS OF CYLINDERS. (Fig. 26).

The outline of the shadow of a cylindrical surface on a plane can evidently be determined by finding the shadows of the two shade lines--which are straight lines, and the shadows of those portions of the circular outline of the top and base that lie between the points at which the lines of shade cross the bases. These will be elliptical, and it is best to determine by methods already given for the shadows of entire circles. As can readily be seen, the width of the elevation of the shadow of a cylinder on a vertical plane will be equal to the diagonal of a square having the diameter of the cylinder for a side and will also be symmetrical about the shadow of the axis of the cylinder. This fact can be conveniently put into use in many cases.

with reviewed of the year
 1961. In order to be
 able to do this, it
 is necessary to have
 a good record of
 the work done during
 the year. This can be
 done by keeping a
 diary or a log book.
 The diary should be
 kept up to date and
 should contain a
 record of all the
 work done, including
 the dates, the
 names of the people
 concerned, and the
 results of the work.
 The log book should
 be kept in a separate
 book and should
 contain a record of
 the work done, including
 the dates, the
 names of the people
 concerned, and the
 results of the work.

APPENDIX

1. The first part of
 the appendix is a
 list of the names of
 the people who were
 involved in the work.
 2. The second part
 of the appendix is a
 list of the dates on
 which the work was
 done.
 3. The third part
 of the appendix is a
 list of the results
 of the work.

REFERENCES

1. Smith, J. (1961).
 The work done during
 the year 1961.
 2. Jones, M. (1962).
 The work done during
 the year 1962.
 3. Brown, K. (1963).
 The work done during
 the year 1963.

23. THE SHADOWS ON CYLINDRICAL SURFACES.

1. The Shadows of a Straight Line on an Upright Cylinder,

The shadow of a straight line parallel to both the V and H planes will be a circle whose radius is equal to the radius of the cylinder and the elevation of whose center lies on the elevation of the axis of the cylinder, below the elevation of the line a distance equal to the distance of the line in front of the axis of the cylinder. This should be clear from Fig. 28.

The shadow on the surface of a line perpendicular to the elevation plane and parallel to the plan plane is a line at 45° (Art. 14, paragraph 4). The shadow of the end of the line would be found by direct projection. (Fig. 28). The shadow of any other straight line would be formed by the direct projection onto the surface of the cylinder of enough points of shadow to determine the curve of shadow.

2. The shadow on an Upright Cylinder of a Larger Cylinder whose axis coincides with the Axis of the Smaller Cylinder.

Evidently the shadow line will be a curve of no easily constructed geometrical form. Hence it becomes necessary to find of that curve by means of direct projection enough points to determine the direction of the curve. Since the outline of the shadow will be determined by the shadow of a certain portion of the circle bounding the lower surface of the cylinder, by means of direct projection from points in this circle on the surface can be found any number of points desired. However, certain points are of more importance in determining shape of the shadow than others. Those points are naturally enough, the points where the shadow crosses the lighted profile of the cylinder, the point where it crosses the shade line, and the point where it crosses the elevation of the axis, and where it is closest to the elevation of the line casting the shadow. By inspection it can be seen that the highest point of shadow lies on the diagonal axis on the left of the center, for on that line the rays strike the surface at the true angle.--(The angle ϕ).

Therefore, it is determined first of all what points on the circle cast shadow on these lines mentioned and then as many additional points are determined as are deemed necessary to the correct drawing of the shadow. If the object be small, then naturally the determination of the four points mentioned is sufficient: if the object be large, then more points must be determined. The method of determination is shown in Fig. 29. The point on the profile line

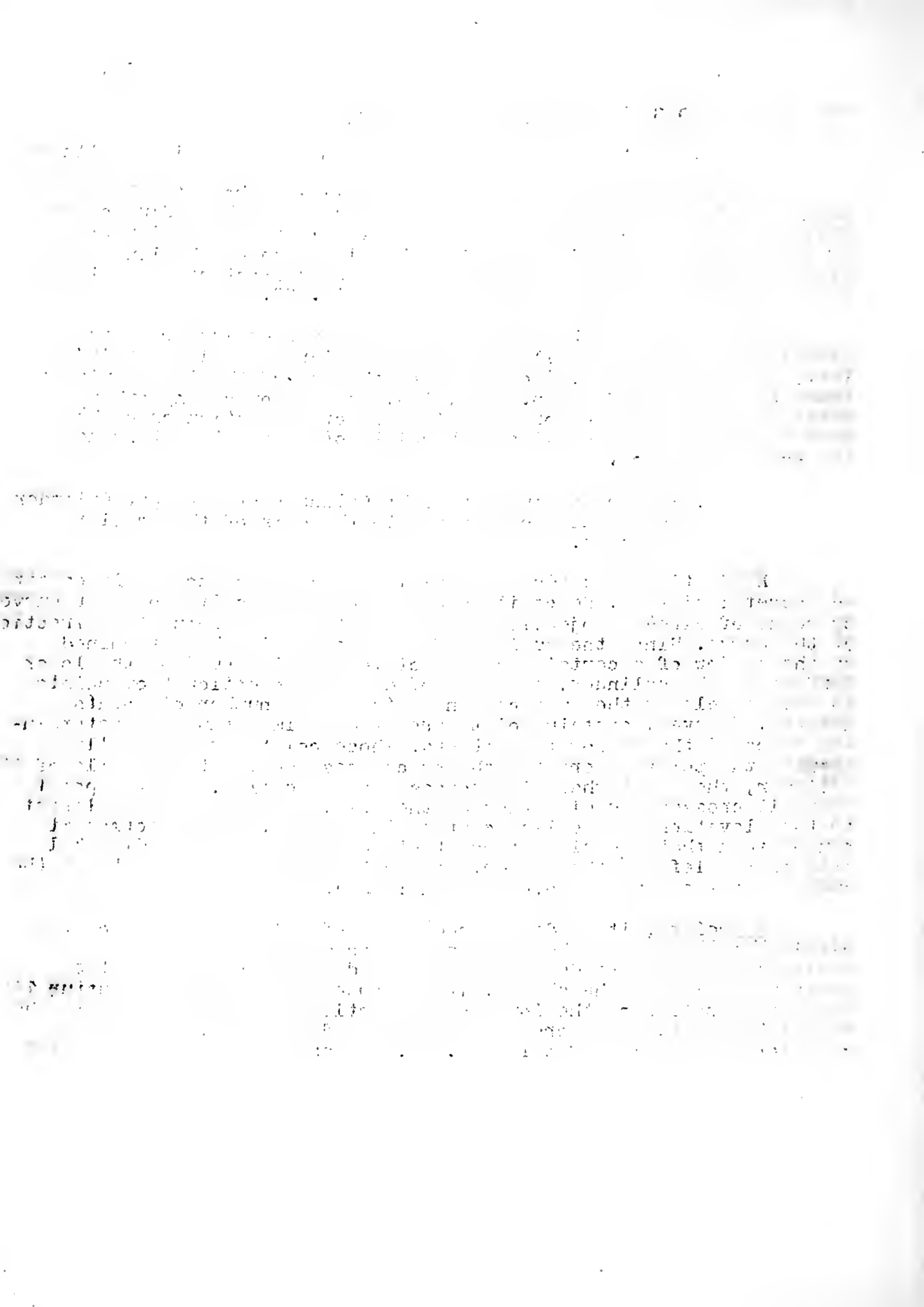

and that on the axis of the cylinder are at the same distance below the line casting the shadow. The determination, therefore, of the position of either one will be sufficient to determine the position of the other.

24. THE SHADES AND SHADOWS OF HOLLOW CYLINDERS.

In the drawing of the sections of buildings it is often necessary to determine the shades and shadows of hollow cylinders, as for instance in the section of the cupola of a dome, or that of a horizontal barrel vault or that of an arch. The methods of determining the points necessary to give the correct general shapes of the shades and shadows on such cylindrical surfaces are shown in Fig.30,31,32.

25. THE METHOD OF AUXILIARY SHADOWS

The principles upon which the application of this method is based are:-

1. If upon any surface of revolution a series of auxiliary curves be drawn, the shadow of the surface will include the shadows of all the auxiliaries, and will be tangent to those that cross the shade line of the surface at points which are the shadows of the points of crossing.
2. The point of intersection of two shadow lines is the shadow of the point of intersection of these lines if they are intersecting lines; if the shadow of the point where the shadow of one of the lines crosses the other line, if they are not intersecting lines. If, therefore, the shadows of two lines intersect or come tangent in a point, the position of the point of tangency or the point of intersection of the two lines casting the shadow may be determined by tracing back along the ray to the line in question. Evidently ease of construction and the necessity of accurate drawing make it necessary to choose auxiliary lines whose shadows may be easily and accurately determined.

26. THE SHADES ON AND SHADOWS OF CONES.

The Conical forms ordinarily met with in architectural work are those with vertical axis--as for example, the roof of a cylindrical tower, the lower part of a wall lamp, etc. The discussion to follow will be limited, therefore, to upright cones.

1911

THE STATE OF TEXAS

COUNTY OF [illegible]

DECLARATION OF DIVORCE

I, [illegible], do hereby certify that [illegible] is a resident of the County of [illegible] State of Texas.

[illegible] and [illegible] were lawfully married in the County of [illegible] State of Texas, on the [illegible] day of [illegible] 19[illegible].

ARTICLE I

of the

[illegible] and [illegible] have been living apart for a period of [illegible] months.

[illegible] and [illegible] have no children together, and [illegible] is not pregnant.

[illegible] and [illegible] have no property, real or personal, which they own jointly or in common.

[illegible] and [illegible] have no debts or liabilities, and [illegible] is not indebted to [illegible].

ARTICLE II

[illegible] and [illegible] have no children together, and [illegible] is not pregnant.

[illegible] and [illegible] have no property, real or personal, which they own jointly or in common.

[illegible]

The surface of a cone cannot be represented in any one of the three planes of projection by lines. Therefore, the shade lines cannot be found by the processes applied to the cylinder. From inspection it can be seen that the shade lines will be formed by planes of rays tangent to the surface of the cone. They will be straight lines passing through the apex and crossing the line of the base. Since in projection, the shade of the apex will coincide with the projections of the apex, then, in order to find the projection of the shade lines it becomes necessary to determine only points at which the shade lines cross the projection of the base. To secure those points, the method of auxiliary shadows is used.

The outline shadow of the cone on any plane will be determined by shadows of the base, the apex and the shade line. If, therefore, as in Fig. 33, the shadow of the apex and the shadow of the base be cast independently upon any given plane, then the shadows of the shade lines must be $A_1s, B_1s,$ and A_1s, C_1s . Points $B_1s,$ and C_1s , common to the shadows of the shade line and the shadow of the base, must be the shadows of points common to the shade line and base, namely, the shadows of points common to the shade where the shade lines cross the base line. By passing back from B_1s and C_1s along rays of light to the base can be found points B and C , and thus shade lines $A B$ and $A C$ constructed.

In finding the points B and C geometrically some method that will give absolute accuracy must be used. Therefore, to find the points B and C in elevation the shadows of the cone on either a horizontal plane through its base, or on a 45 degree vertical plane through its axis are used as auxiliaries. Figs. 35 and 36 illustrate the application of the method wherein is used as an auxiliary, the shadow on the horizontal plane. (Fig. 35) In the geometrical construction shown in Fig. 36, the shadow of the cone B_2s, A_2s, C_2s is simply for the sake of convenience superposed on the elevation of the cone and points B_1 and C_1 thus determined.

In Fig. 38, the points E_1 and F_1 are first determined by casting the shadow of the cone on the 45 degree auxiliary plane, then since the shadow A_1, E_1, K_1, F_1 is that of the base of the cone on the 45° auxiliary plane, then from E_1 and F_1 in elevation, rays are passed at 45° to cut the elevation of the base, and thereby determine the position of the points B_1 and C_1 . The shade lines A_1B_1 and A_1C_1 can then be drawn.

27. CONES WITHOUT VISIBLE SHADE LINES.

If, as in Fig. 39, the profile lines of the cone make with the horizontal an angle of 45°, then there is in front elevation no visible shade line. The shade lines in plan are, however, as shown. If, as in Fig. 40, the profile lines make an angle of ϕ or less than ϕ with the horizontal, then the cone has no shade line in plan or elevation.

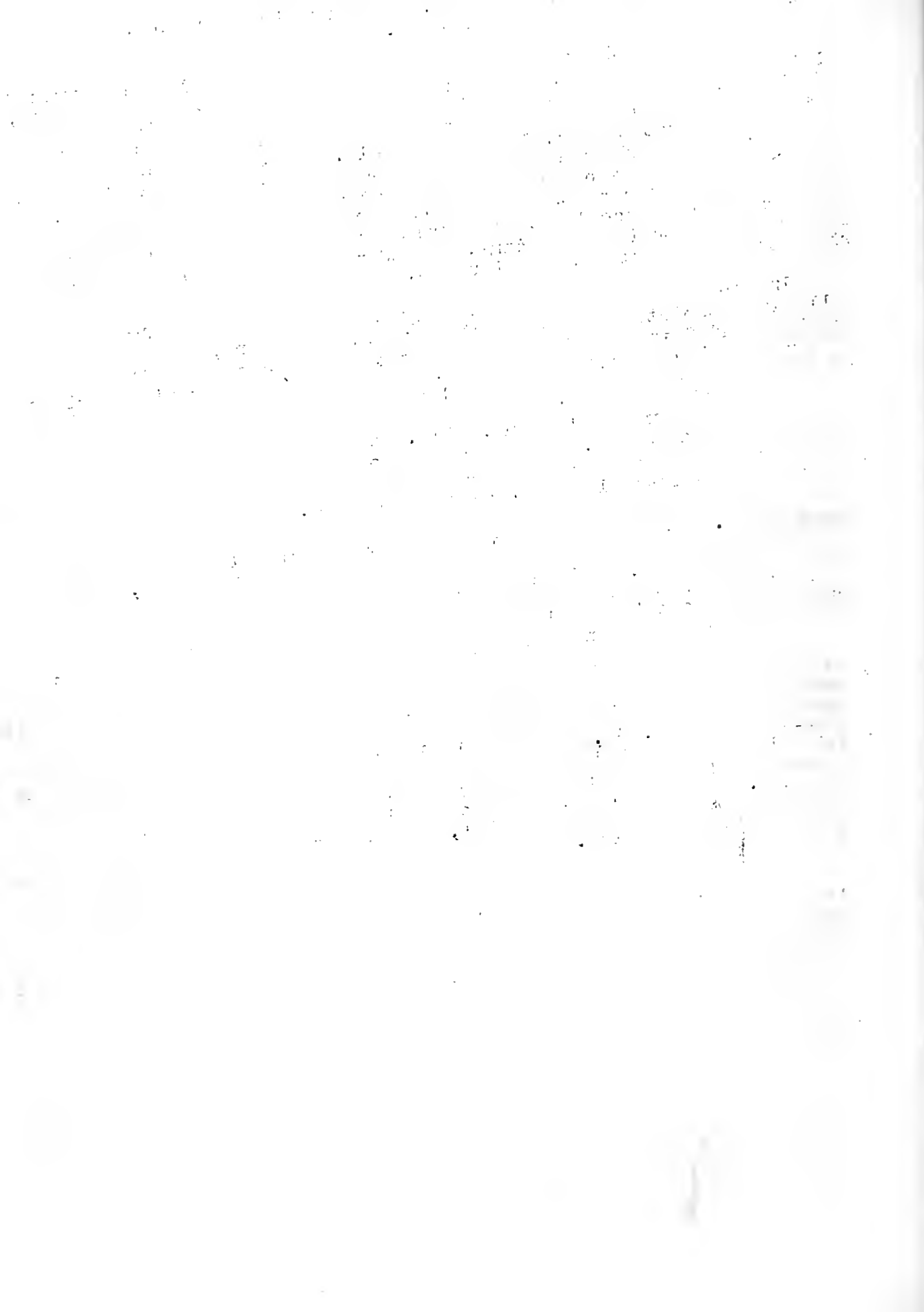

28. THE SHADOWS OF CONES.

The outline of the shadow on any surface can be secured by casting onto that surface the shadows of the apex, of the shade lines and of the profile of the base. If the surface on which the shadow falls be a plane, the shadow of the axis of the cone should be first determined; then on the shadow line can be determined the shadow of the apex then the shadow of the base. Through the shadow of the apex straight lines drawn tangent to the shadow of the base will complete the shadow of the cone.

29. THE SHADES AND SHADOWS OF SPHERES.

The shade lines of a sphere is evidently a great circle of the sphere and is symmetrical about the two forty-five degree axes in the plane and in elevation. It is readily understood that the point where the shade line of any double curved surface of revolution touches the contour lines of the surface in plan or elevation is of course to be found at the point of the contour at which the plan or elevation of a ray is tangent to it.

Therefore, Fig. 41b, to find on the plan the points where the shade lines come tangent to the plan of the contour draw the rays R_2 , tangent to the plan of the sphere. The points thus found evidently give, (Fig. 41a), on the elevation of the equator the points of shade C_1 & D_1 , and by symmetry the points E_1 and F_1 . Points A_1 and B_1 are determined by drawing rays R_1 tangent to the elevation of the sphere. Thus are determined six points on the shade line. To determine the points which will give the length of the minor axis of the ellipse, two equilateral triangles with their apexes at A_1 and B_1 are constructed, and points G_1 and H_1 thus determined. Through these eight points the ellipse of shade can then be drawn. The short construction for the points required is shown in Fig. 41c. The outline of the shadow of the sphere on any surface will be the shadow of the shade line of the sphere, and sufficient points could be determined by direct projection from plan and elevation to fix the shape of the curve. The shadow on a vertical or horizontal plane, however, is generally found by means of the construction shown in Fig. 41d, and is sufficiently accurate provided the shape of the ellipse of shadow is drawn approximately as shown on the figure.

Many mistakes are made by beginners in determining for instance the line of shade on a dome, which is of course only part of a sphere. The visible shade line can be determined accurately only by completing the sphere.

Faint, illegible text in the upper left quadrant.

Faint, illegible text in the upper right quadrant.

Faint, illegible text in the lower left quadrant.

Faint, illegible text in the lower right quadrant.

Faint, illegible text at the bottom of the page.

30. THE SLICING METHOD.

In this method the object casting shadow and the object receiving the shadow are first cut through by a vertical planes parallel to the rays of the light. The elevations of the lines of intersection of the planes with the surfaces in question are then determined and then points of shade and shadow are determined on these slices.

The process is explained by Fig. 42, the plan of the object is shown at (a). The plan of a vertical plane at 45° passed through the object would be represented by the line (1). The elevation of the line of intersection of that plane with the surface given would be the dotted line (1). The shadow on the scotia would be cast by the circular edge x y, The shadow of point B₁ would evidently lie at the point B_{1s} where the elevation of ray through (B₁) strikes the line of intersection (1). Plane (2) would give intersection (2), and the elevation of a ray through C₁ would give the shadow C_{1s}. By the use of a sufficiently large number of accurately constructed slices enough points of shadow may be determined to fix the curve of the shadow line.

Because it is a quite easily understood, this method of determining shade and shadow is apt to be abused by the beginner. Firstly, it must be distinctly remembered that the accurate construction of each slice is a slow, tedious process and that the line of slicing when determined will be sufficient to give but one point of shade or shadow and, secondly, that a point of shade determined by drawing a ray tangent to such a slice line will not be accurate in its position. While the position of the slicing planes may be chosen so as to give the most easy construction and valuable results, yet the slicing method is one to be used only when no other can be supplied. It cannot be used at small scale. The shapes of shadow and shade lines determined by this method must be so determined at a scale that will allow of accurate construction and may then be copied at small scale by proportion.

By means of this method can be determined the shades and shadows of scotias, and those on the more complicated vase forms. However, those shadows can often be more accurately determined by the use of the 45degree auxiliary plane.

31. THE SHADOW OF A CIRCULAR NICHE WITHIN A SPHERICAL HEAD

The outline of the shadow will be formed by the shadow of the circular outline of the head of the niche and by the shadow of the straight line which represents the left hand side of the niche. The lines casting the shadow can be represented in plan by the line

... of the ...
... of the ...
... of the ...

... of the ...
... of the ...
... of the ...

... of the ...
... of the ...
... of the ...

... of the ...
... of the ...
... of the ...

SECRET

... of the ...
... of the ...
... of the ...

A2 C2 B2, Fig. 4 6. The Portion of the niche in elevation up to line A1 O1 B1 can be represented in plan by a semicircle. Points of shadow Als Els Dls can be found by direct projection from the plan and elevation. The curve of shadow will evidently start at Als and end at Cls where the ray R₁ comes tangent to the elevation of the profile. To find points of shadow on the spherical head of the niche auxiliary vertical planes such as x and y are passed through the surface of the niche and the elevation of the lines of their intersection with the surface of the niche found. On these planes are then cast the shadow of the semicircular outline of the head of the niche and the points Fls and Gls, thus Fls and Gls are points of shadow of the semicircular head of the niche because they are points common to the surface in question and to the shadow of the semicircular head.

At small scale the points of shadow to be determined are Als, Dls, and Cls. Als and Cls are easily determined, and Dls may be placed on the elevation of a ray through O₁ a distance from O1 equal to 1/3 of the radius of the niche. (Fig.47). The shadow line must not cross the outline at Cls but must be tangent to the outline at that point.

32. THE SHADES ON AND THE SHADOWS OF HORIZONTAL TORI.

As in the case with all double curved surfaces of revolution, the shade line will be symmetrical in plan about the two 45 degree axes. If there can be determined accurately several points on that shade line, then same can be drawn with accuracy through the points thus determined.

33. THE SHADE LINE ON A TORUS.

From the theorem that the point where the shade line of any double curved surface of revolution touches the contour line of the surface in plan or elevation, is found at the point of the contour at which the plan or elevation of a ray is tangent to the contour, there can be determined the position in elevation of the points El A1 Fig. 4 3, By symmetrical construction can be found the points Cl, H1. From the plan by drawing rays tangent to the plan of the contour, which is the equatorial circle of the torus, can be located points G1 and D1. If now, there can be determined the highest and lowest points of shade then the shade line can be constructed with sufficient accuracy. It is evident that the lowest and the highest points will lie in plan somewhere on the axis of the torus that is parallel to the rays of light and that point will be where the ray of light strikes the surface of the torus at the angle 0. If the torus be then revolved about its vertical axis until the point comes into the vertical plane of projection then can be determined the horizontal element on which the point lie s. It lies on the 45 degree axis in plan. By finding the plan or

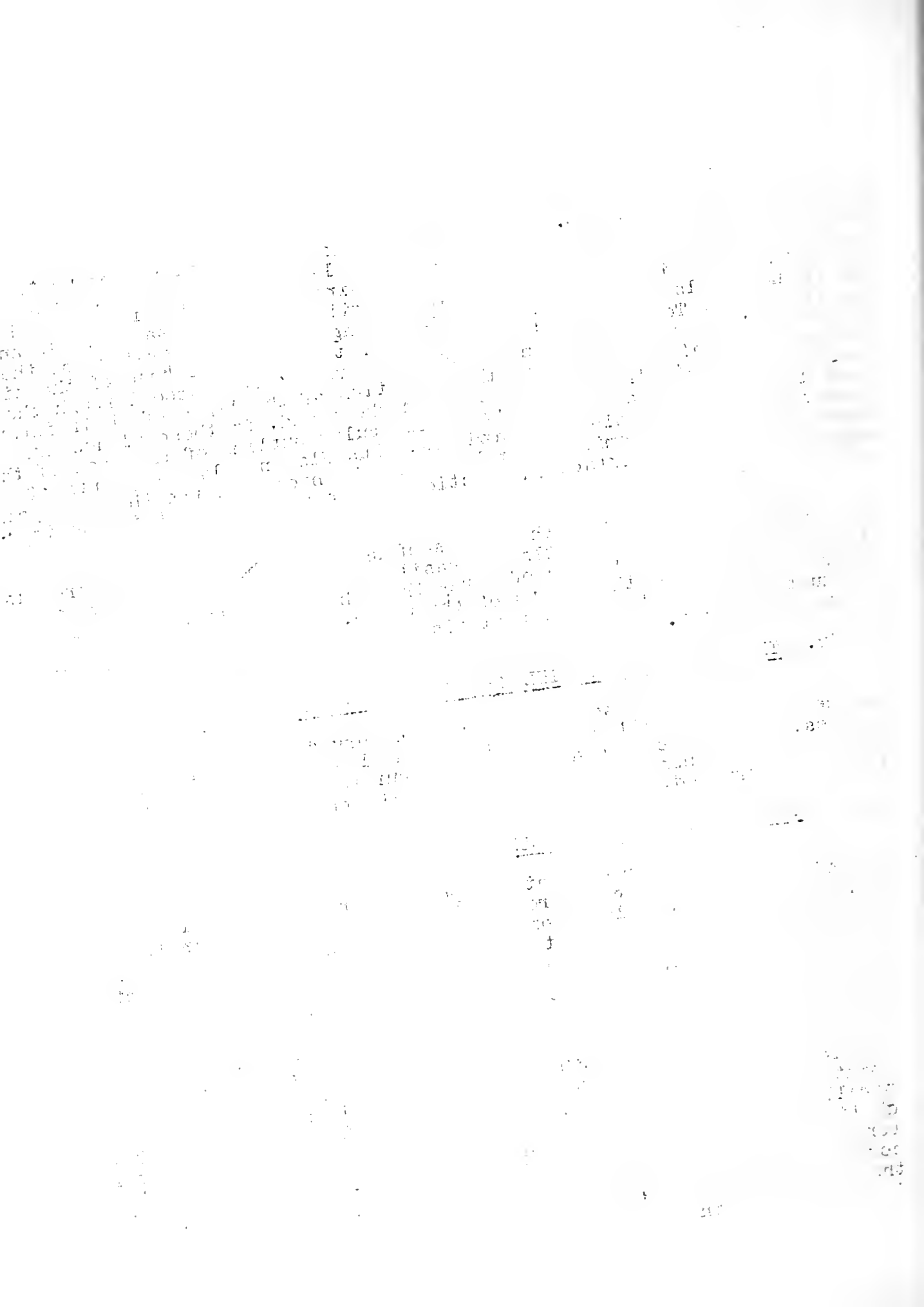

horizontal elements it determines the position of the points desired, namely, B1 and F1. The construction is shown in Fig. 43

34. The SHADOW OF A TORUS.

The outline of the shadow of a torus is the shadow of its shade line, and can be cast on any surface by the direct projection of points in plan and elevation. However, as shown in Fig. 44, the shadow line so nearly corresponds to shadow of the equatorial circle of the torus that at small scale the shadow of the equatorial circle can be used as the shadow of the torus.

35. THE OVAL CURVE OF THE TORUS.

The Shadow of a torus on the 45 degree auxiliary plane is found by casting on that plane the shadows of various horizontal elements of the torus and drawing the envelope of those shadows. The construction is shown in Fig. 45. This shadow is used frequently as an auxiliary, particularly in the finding of the shadows of straight lines and circles on the surface of tori.

SEARCHED BY [unclear] TO [unclear]
[unclear]

[unclear]
[unclear]

[unclear]
[unclear]

[unclear]
[unclear]
[unclear]
[unclear]
[unclear]

[unclear]
[unclear]
[unclear]
[unclear]
[unclear]

[unclear]
[unclear]
[unclear]
[unclear]
[unclear]

[unclear]
[unclear]
[unclear]
[unclear]

[unclear]
[unclear]
[unclear]
[unclear]
[unclear]
[unclear]
[unclear]

SHADES and SHADOWS PLATE I.

By J H Fogarty.

FIGURE 1
THE RAYS OF LIGHT.

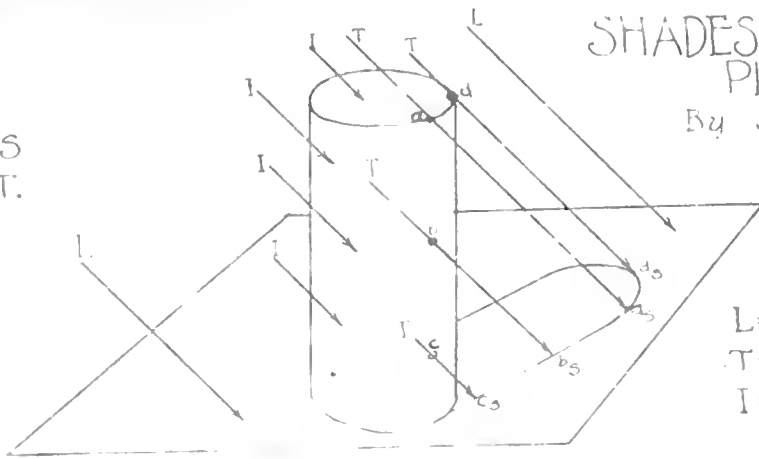

L=LATERAL RAYS.
T=TANGENT RAYS
I=INCIDENT RAYS

FIGURE 2
THE CONVENTION
DIRECTION FOR
THE RAY OF LIGHT

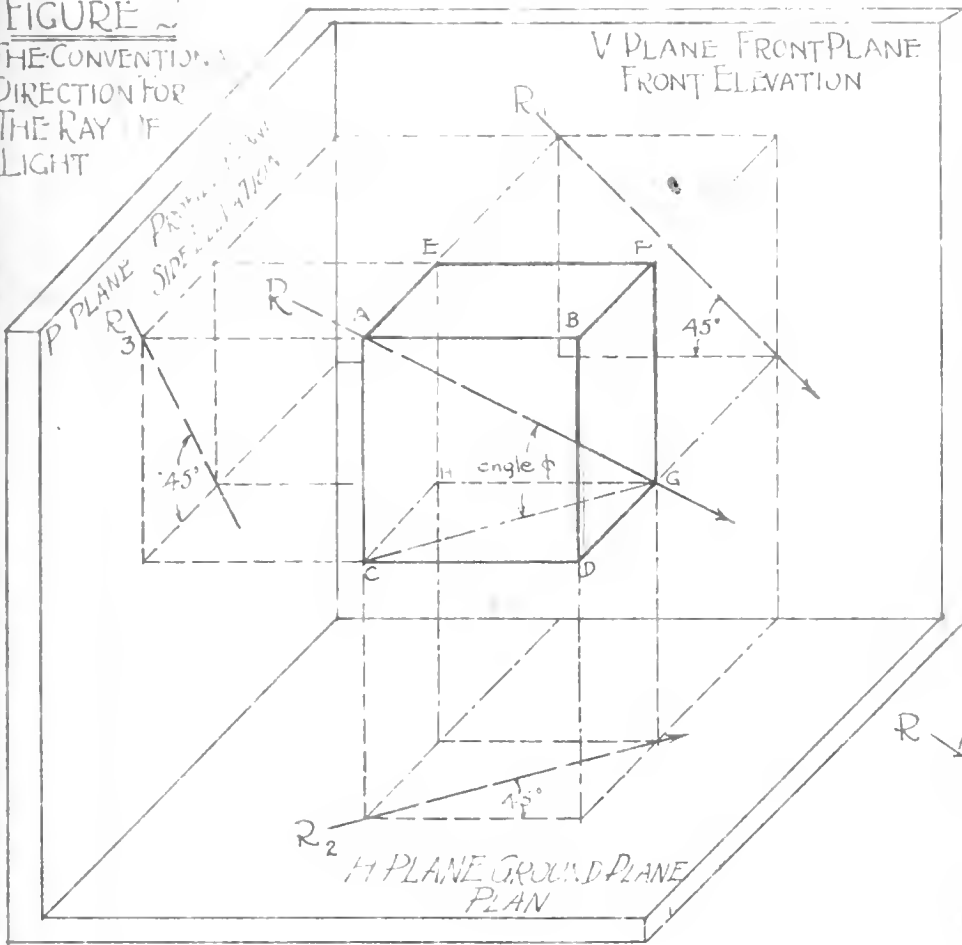

LET ABCDEFGH BE A CUBE
AG=DIAGONAL OF CUBE
R=RAY OF LIGHT PARALELL
TO DIRECTION OF DIAGONAL
R₁=PROJECTION OF RAY ON V
PLANE OR ELEVATION OF RAY
R₂=PROJECTION OF RAY ON H
PLANE OR PLAN OF RAY
R₃=PROJECTION OF RAY ON P
PLANE OR SIDE ELEVATION OF RAY
∠AGC=TRUE ANGLE OF RAY
OR ANGLE φ

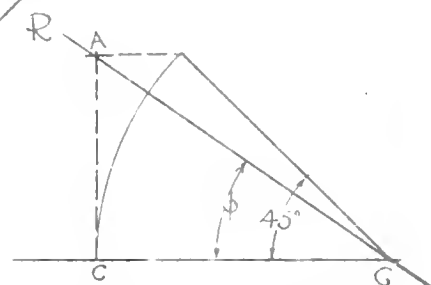

GEOMETRIC CONSTRUCTION FOR ANGLE φ

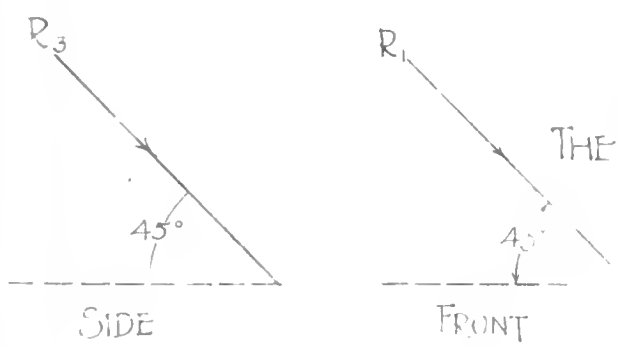
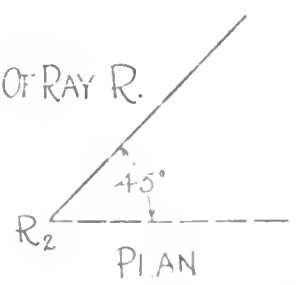

FIGURE 3
THE THREE PROJECTIONS OF RAY R.





SHADES & SHADOWS Plate II

By J.H. Ferguson

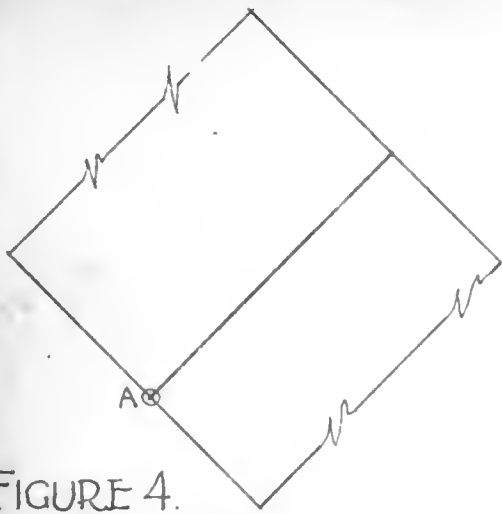

FIGURE 4.
PLANE OF RAYS.
DEFINITION:

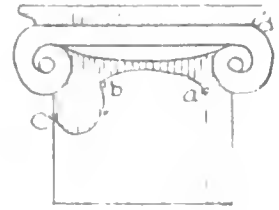
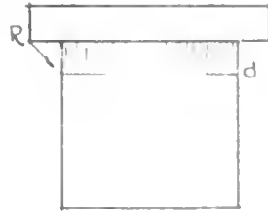

FIGURE 5.
POINTS OF LOSS.
POINTS a, b, c, d are POINTS OF LOSS.
DEFINITION:

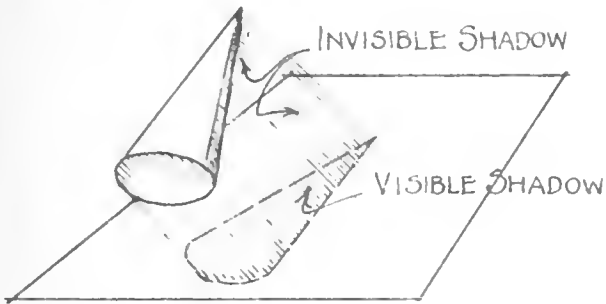

FIGURE 6.
INVISIBLE AND VISIBLE SHADOWS.
DEFINITION:

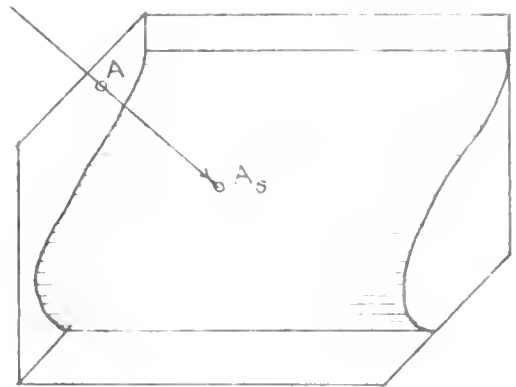

FIGURE 7.

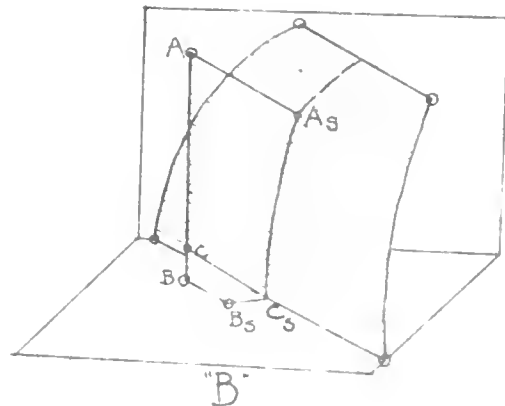
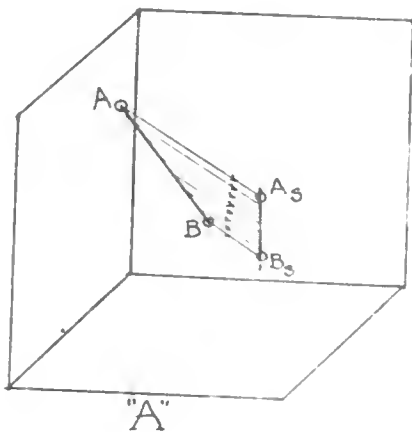

FIGURE 8
IN "A" SHADOW OF AB FALLS ON PLANE
IN "B" SHADOW OF AB FALLS PARTLY ON
GROUND, PARTLY ON CURVED SURFACE.



SHADES & SHADOWS

PLATE III

11 12 13 14 15 16 17 18 19 20 21 22 23 24 25 26 27 28 29 30 31 32 33 34 35 36 37 38 39 40 41 42 43 44 45 46 47 48 49 50 51 52 53 54 55 56 57 58 59 60 61 62 63 64 65 66 67 68 69 70 71 72 73 74 75 76 77 78 79 80 81 82 83 84 85 86 87 88 89 90 91 92 93 94 95 96 97 98 99 100

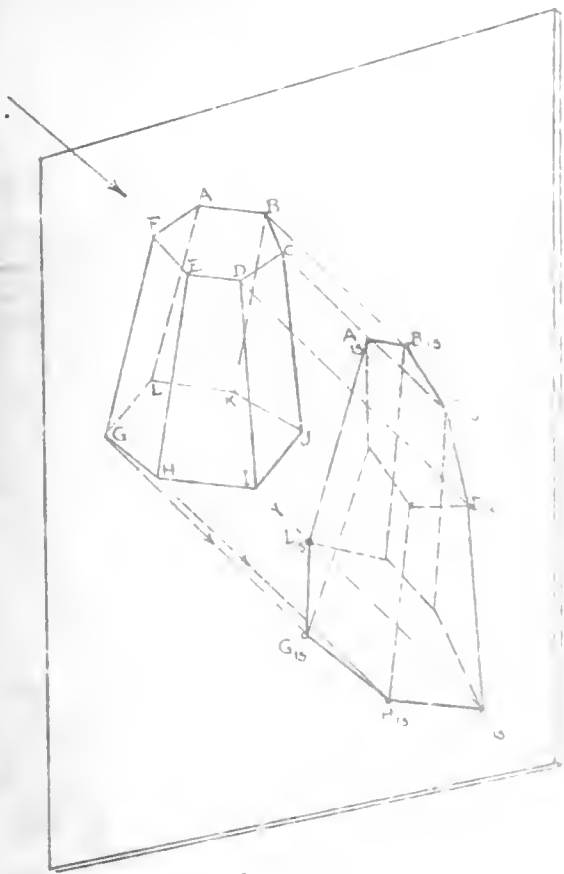

FIGURE 9

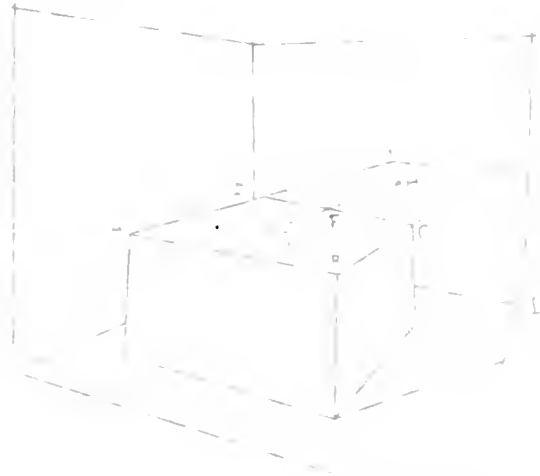

FIGURE 11

FIGURE 11 IS AN IMAGINARY SECTION OF THE TOP OF THE CUBE. THE IMAG. AP. LINE THROUGH THE CUBE MAY BE BEYOND THE LINE AND THE PART BEYOND WILL BE HIDDEN.

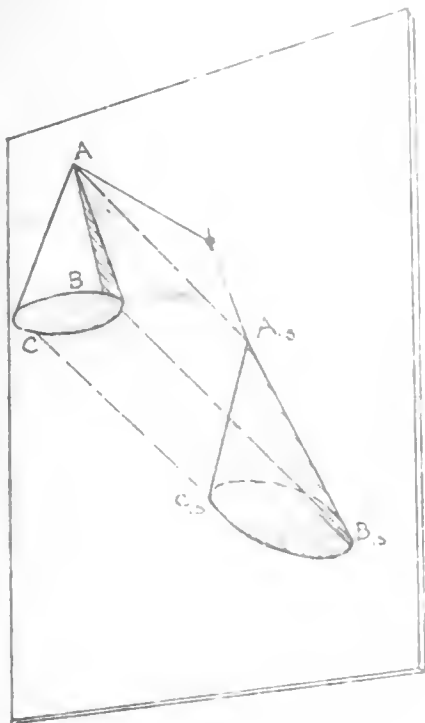

FIGURE 10

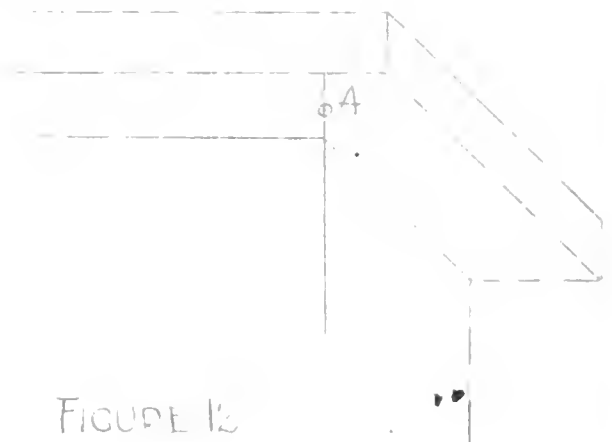
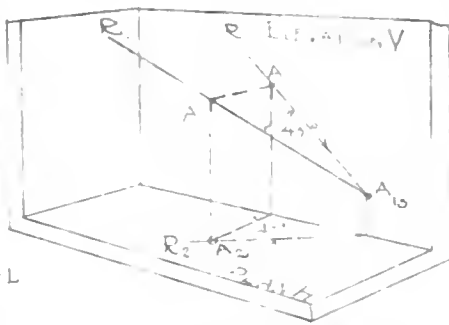
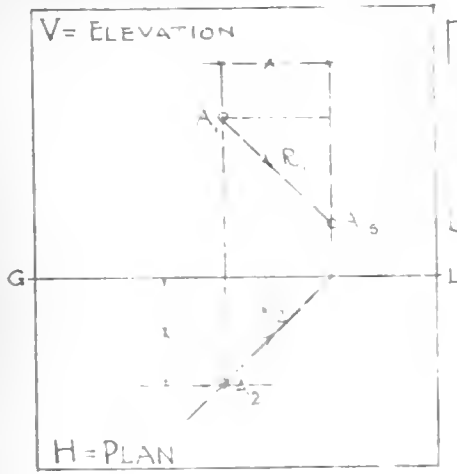

FIGURE 12



SHADES & SHADOWS PLATE IV

THE SHADOWS OF
POINTS & LINES
By Jif Forythe



PERSPECTIVE METHOD
A = POINT IN SPACE
R = RAY IN SPACE

FIGURE 13
THE SHADOW OF ANY POINT

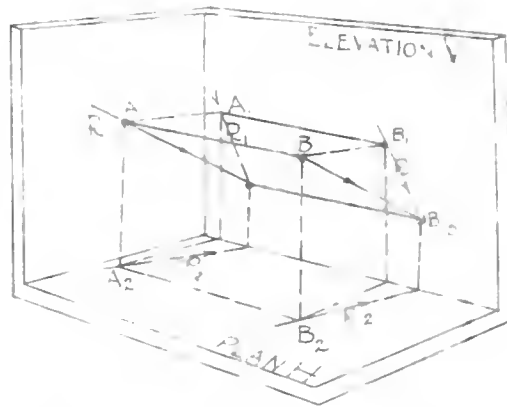
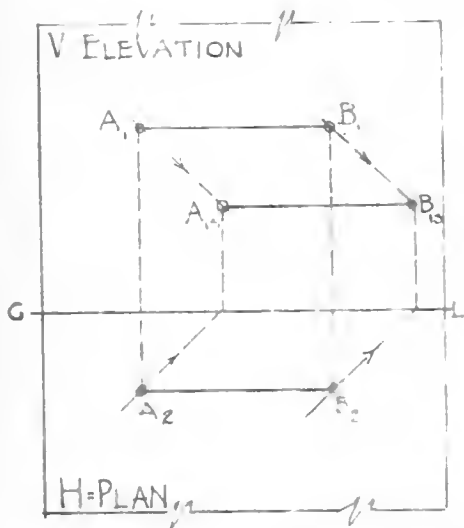

FIGURE 14
SHADOWS OF LINES PARALLEL TO ELEVATION PLANE

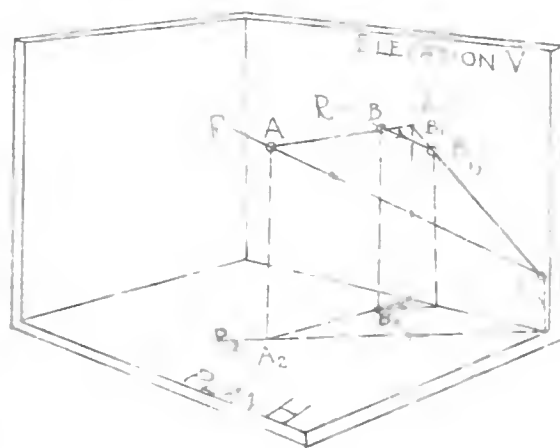
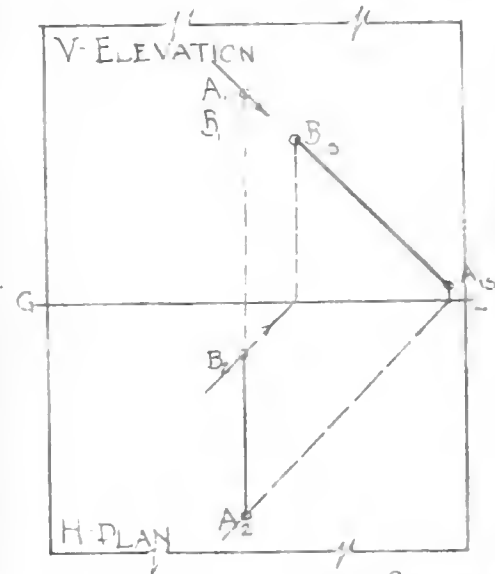

FIGURE 15
SHADOW OF A LINE PERPENDICULAR TO ELEVATION PLANE



SHADES & SHADOWS PLATE V

By J H Fogarty.

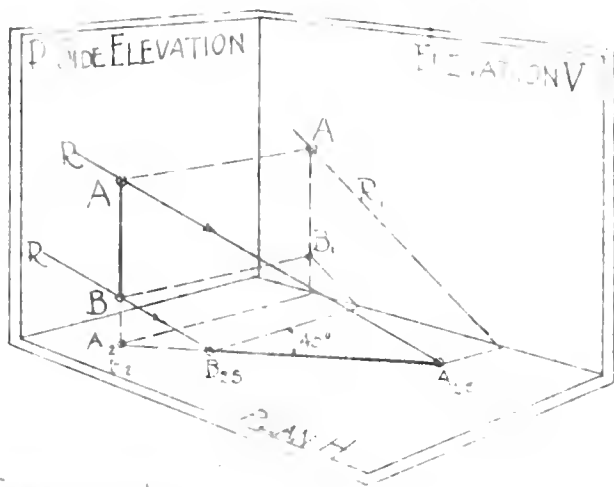
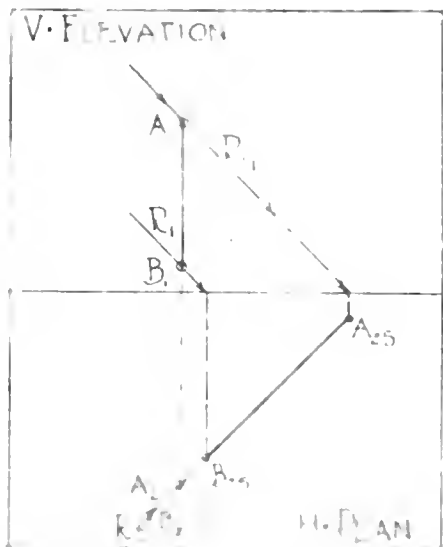

FIGURE 16

THE SHADOWS OF A LINE PERPENDICULAR TO PLAN PLANE ON PLAN PLANE.

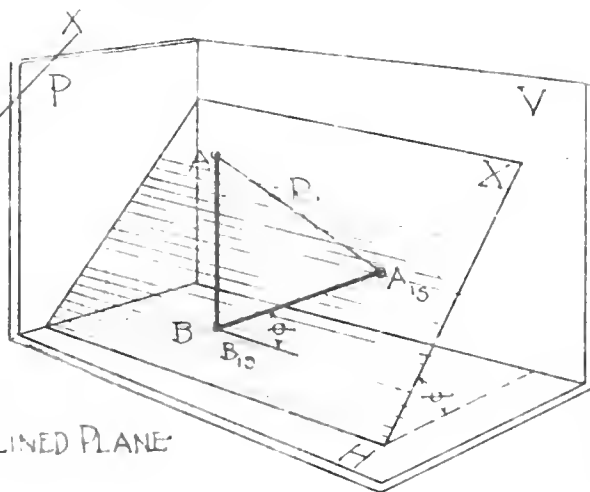
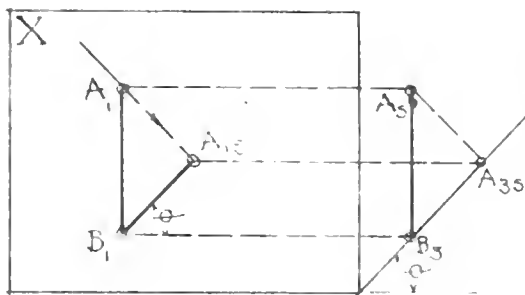

FIGURE 17

SHADOW OF VERTICAL LINE ON INCLINED PLANE

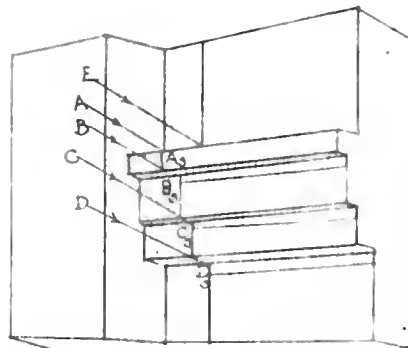
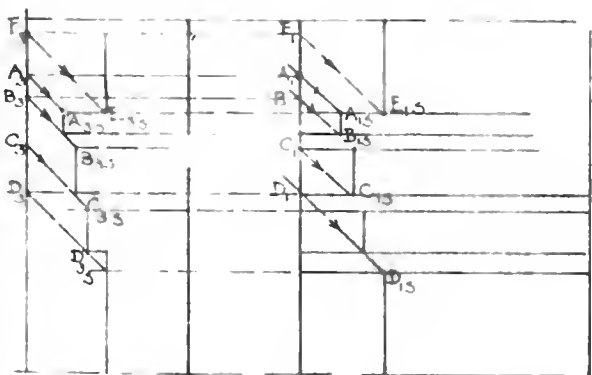
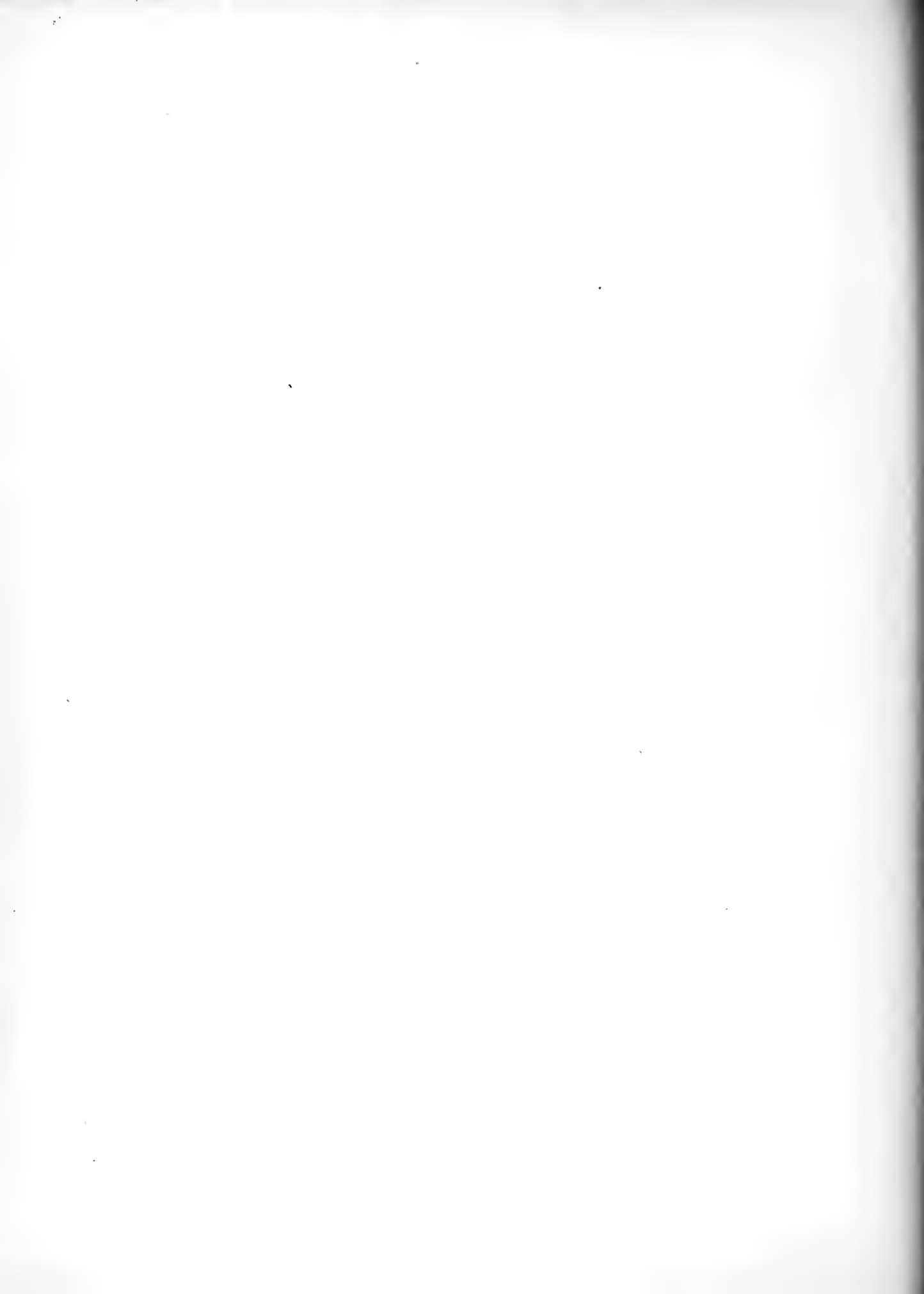

FIGURE 18

SHADOW OF VERTICAL LINE ON SERIES OF HORIZONTAL MOULDINGS.



SHADES & SHADOWS PLATE VI

By J.H. Fogarty

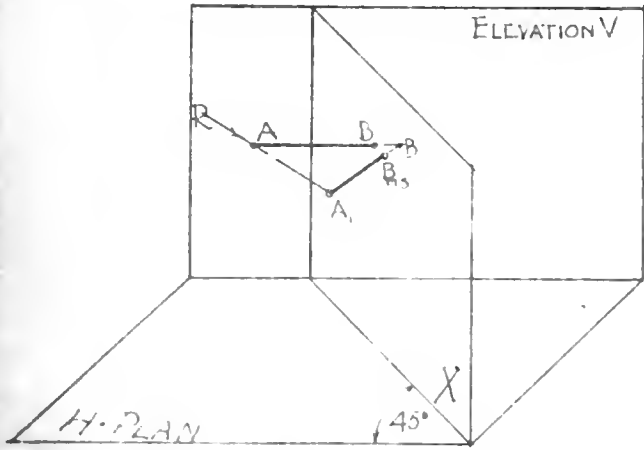

FIGURE 19(a)

THE SHADOW OF A LINE PARALLEL TO ELEVATION AND PLAN PLANES ON A PLANE AT 45°

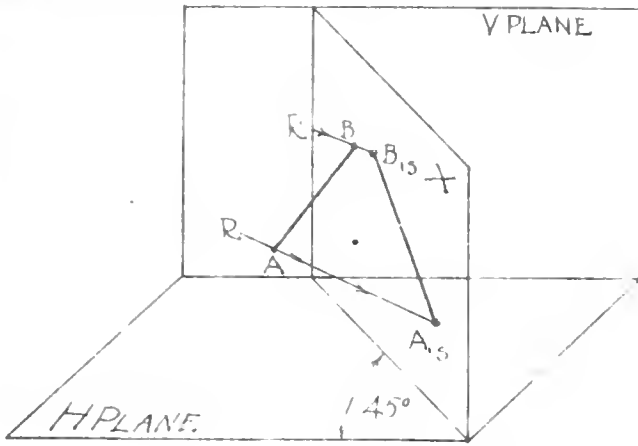
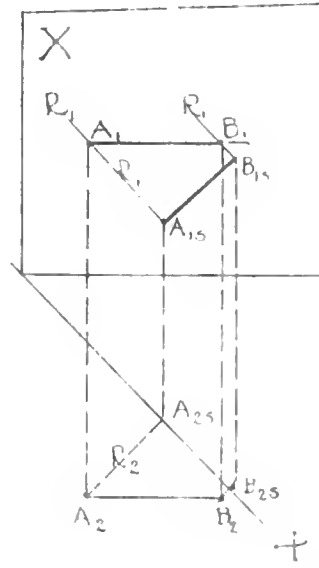

FIGURE 19(b)

THE SHADOW OF A LINE PERPENDICULAR TO ELEVATION PLANE ON A PLANE AT 45°

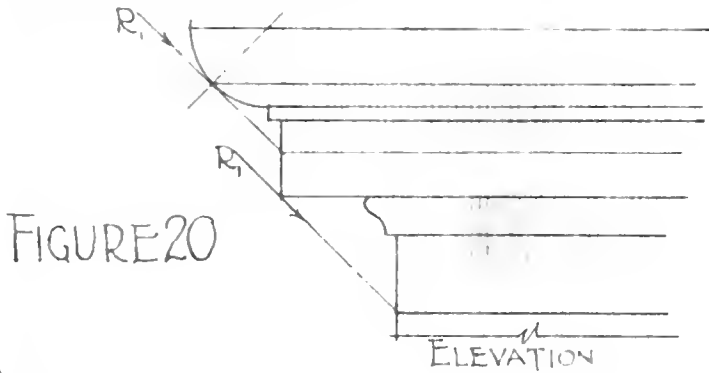
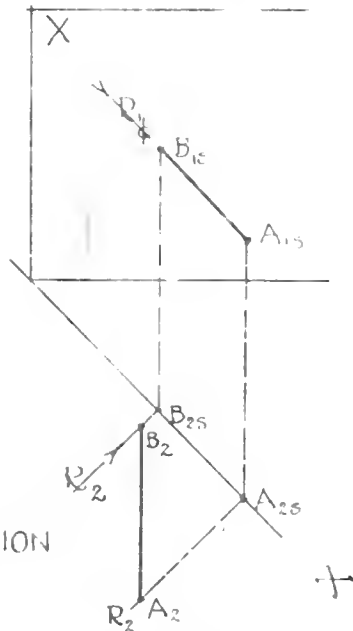

FIGURE 20

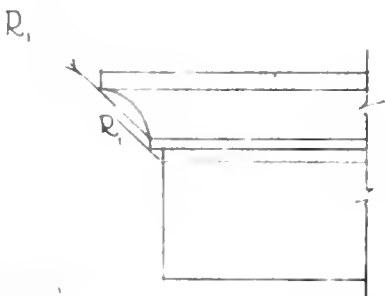
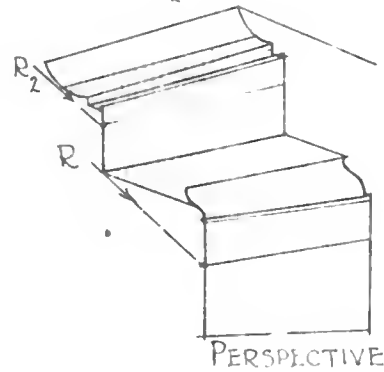
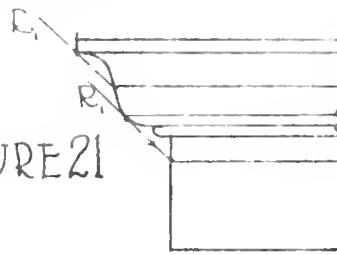
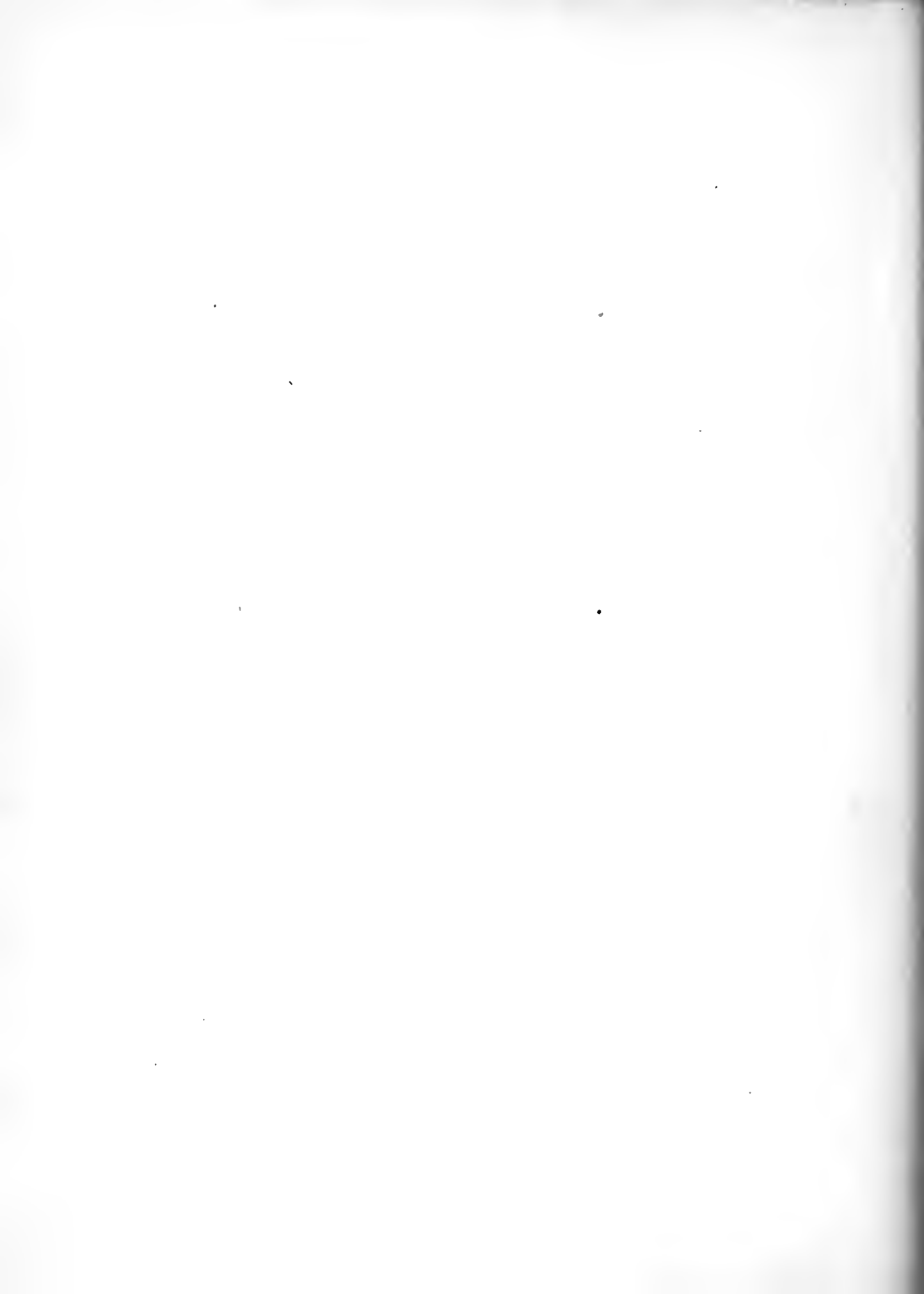

FIGURE 21



THE SHADES AND SHADOWS OF A HORIZONTAL GROUP OF MOULDINGS.



SHADES & SHADOWS PLATE VII

By J. H. Terry, the

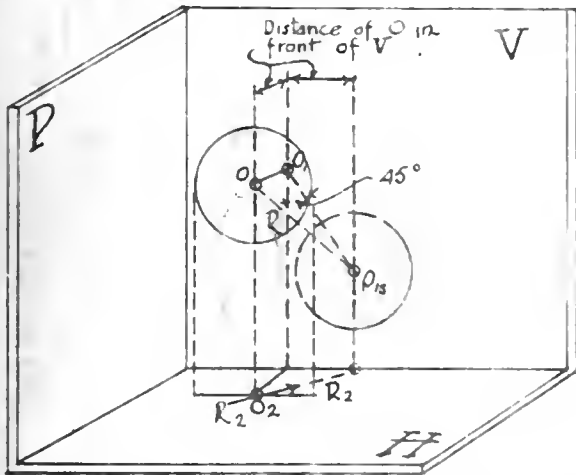

CIRCLE IN PLANE PARALLEL TO PLANE ON WHICH SHADOW IS CAST

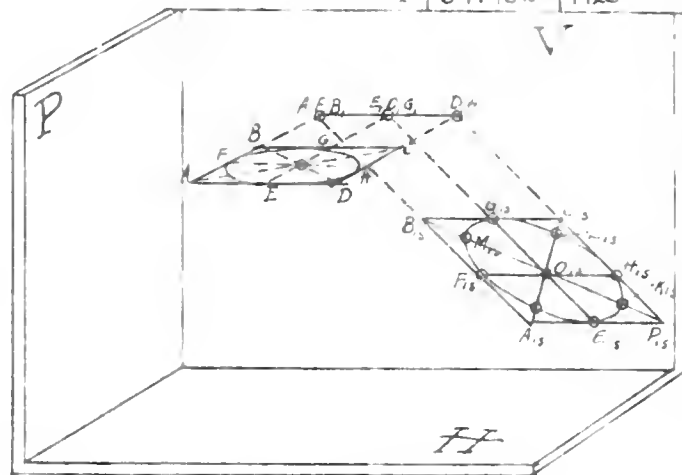

CIRCLE IN PLANE PERPENDICULAR TO PLANE ON WHICH SHADOW IS CAST.

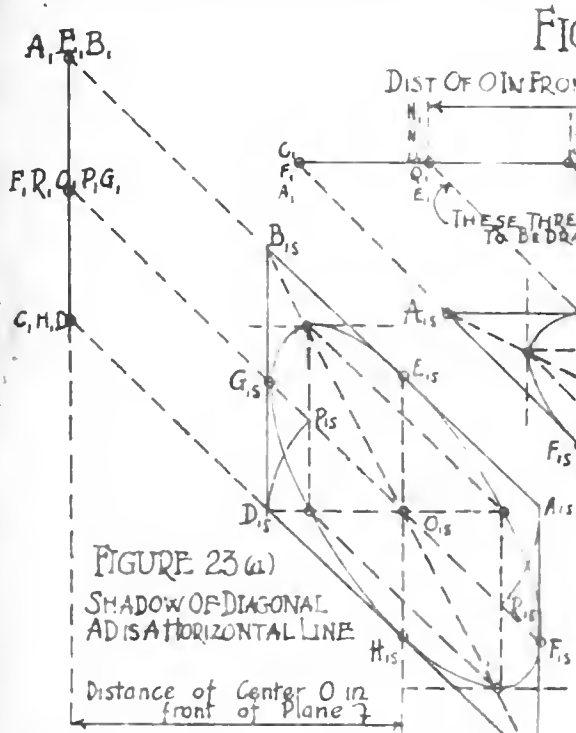

FIGURE 23 (a)
SHADOW OF DIAGONAL AD IS A HORIZONTAL LINE

FIGURE 22

DIST OF O IN FRONT OF PLANE

THESE THREE LINES TO BE DRAWN FIRST

SHADOW OF DIAGONAL BC IS A VERTICAL LINE EQUAL TO DIAMETER OF CIRCLE

FIGURE 23 (c)
CIRCLE IN PLANE PERPENDICULAR TO ELEVATION & PARALLEL TO PLAN

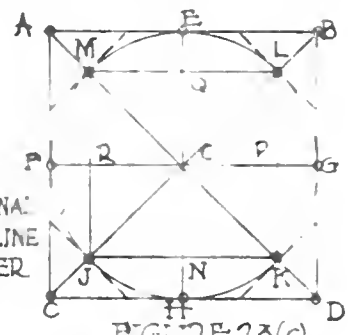

TO FIND SHADOW OF POINT N USE CENTER O1 AND RADIUS O1C1 THRU N1, THUS FOUND. DRAW SHADOW OF CIRCUMSCRIBED SQUARE.

NOTE:-

ALL POINTS ON AD ARE TO BE FIRST TO LETTERS IN FIG 23(C).

CIRCLE IN PLANE PERPENDICULAR TO BOTH PLAN & ELEVATION

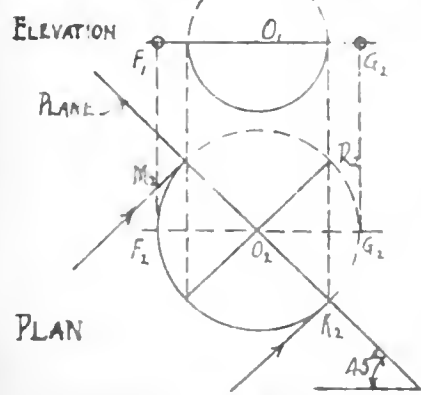

FIGURE 25.

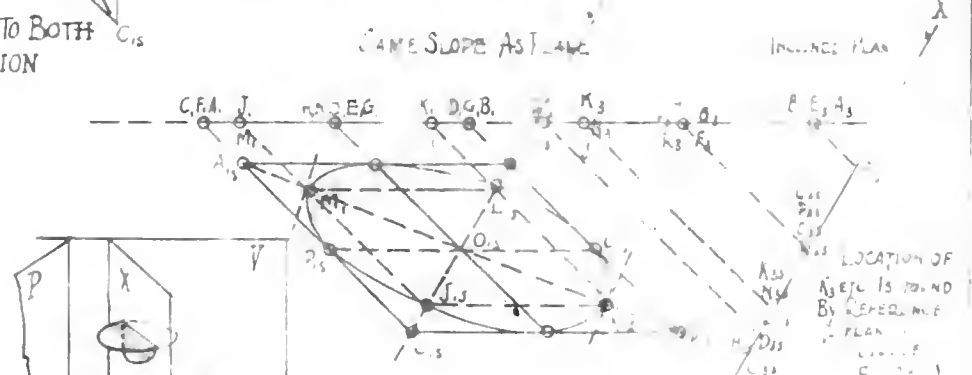
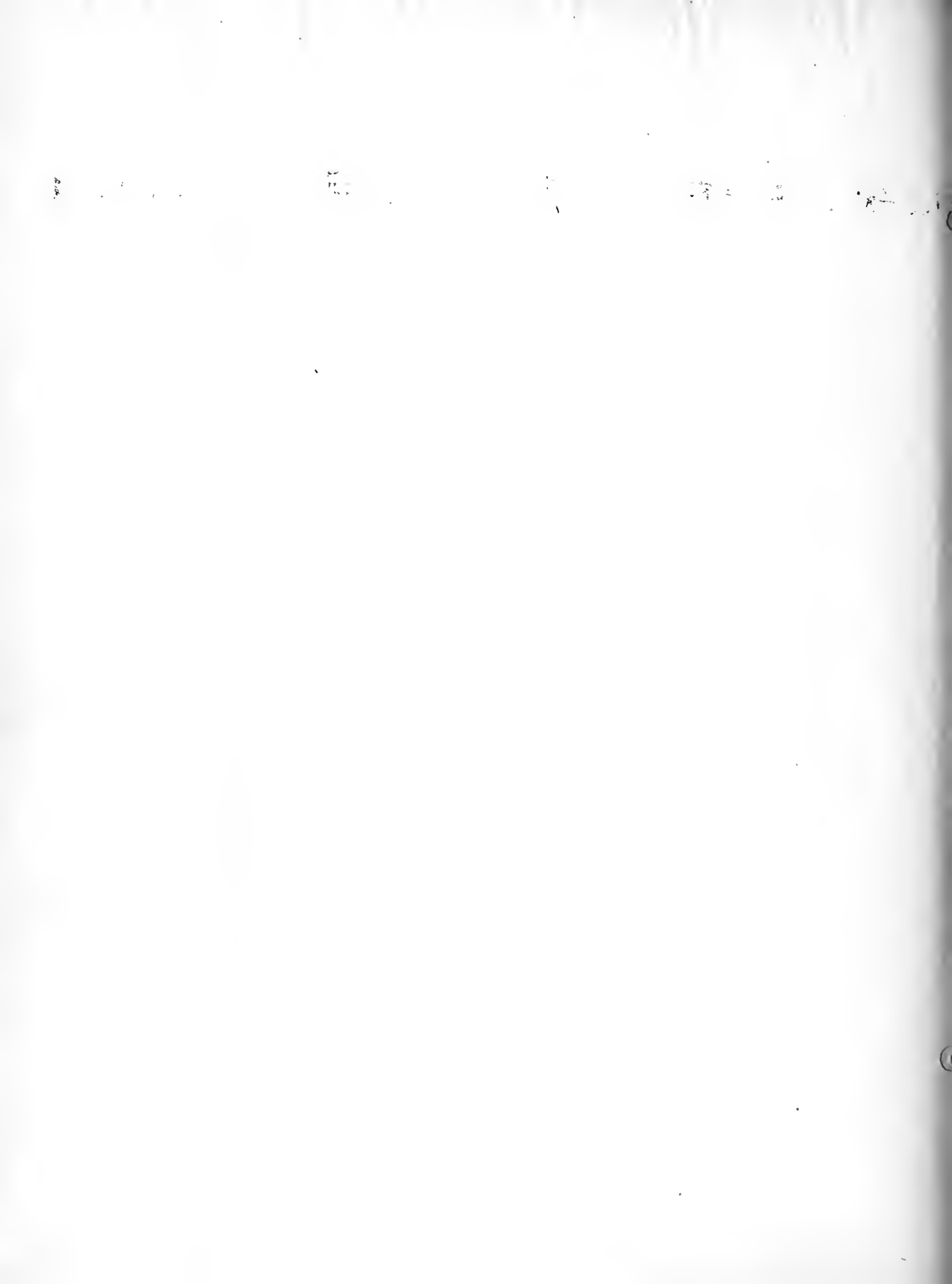

FIGURE 24
SHADOW OF CIRCLE ON INCLINED PLANE

LOCATION OF A2, B2, C2, D2 IS FOUND BY PERPENDICULARS TO PLAN OF PLANE (FIG 24)



SHADES & SHADOWS

PLATE VIII

By J. H. Forsythe.

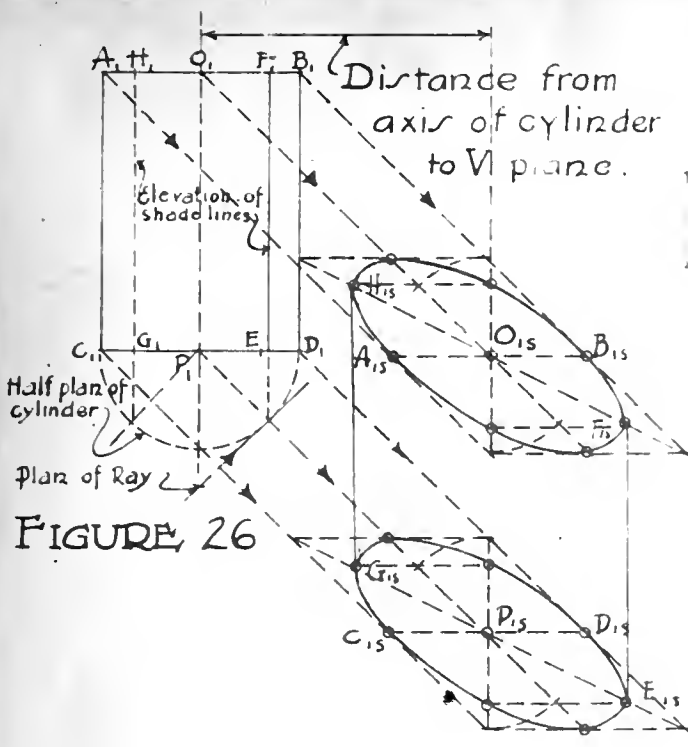

FIGURE 26

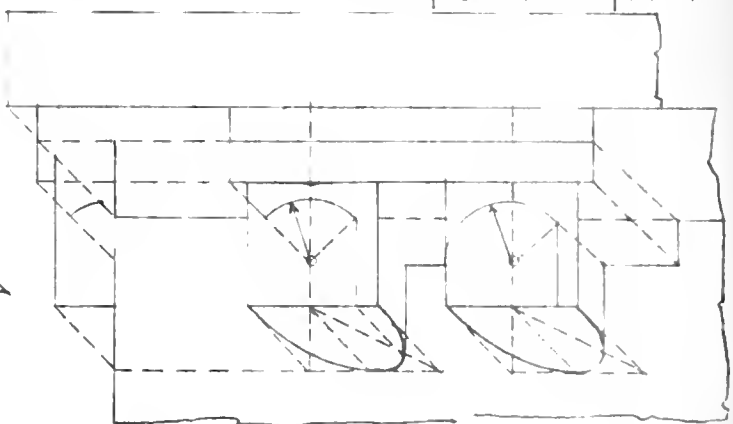

FIGURE 27

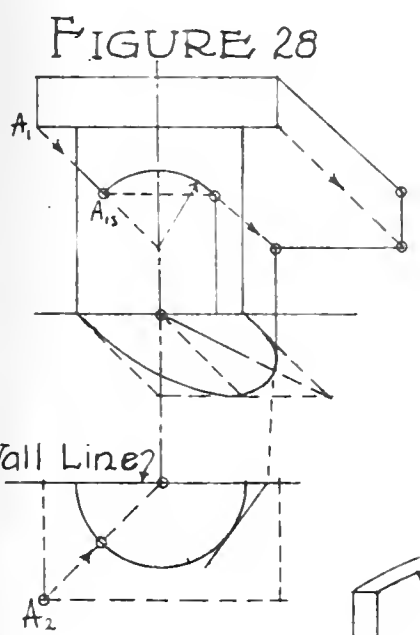

FIGURE 28

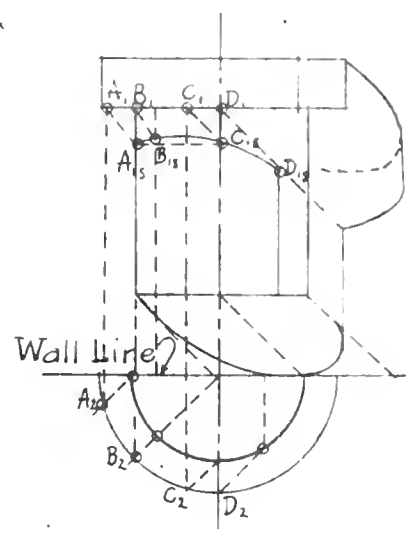

FIGURE 29

SHADES & SHADOWS IN HOLLOW CYLINDERS.

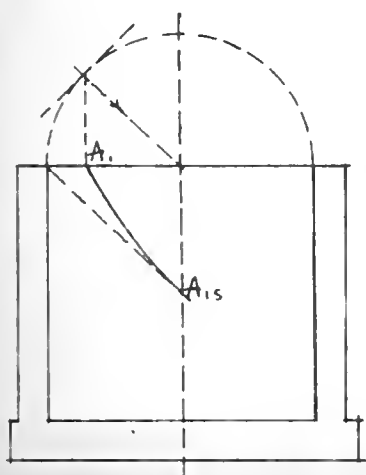

FIGURE 30

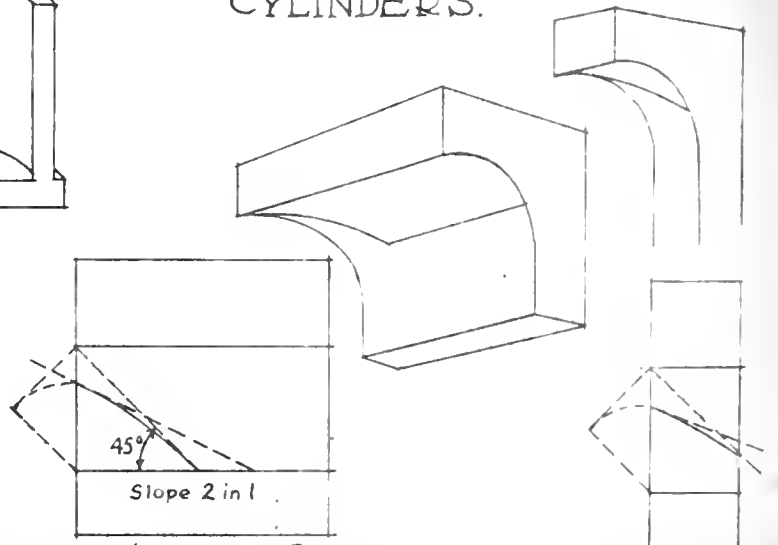

FIGURE 31



FIGURE 32

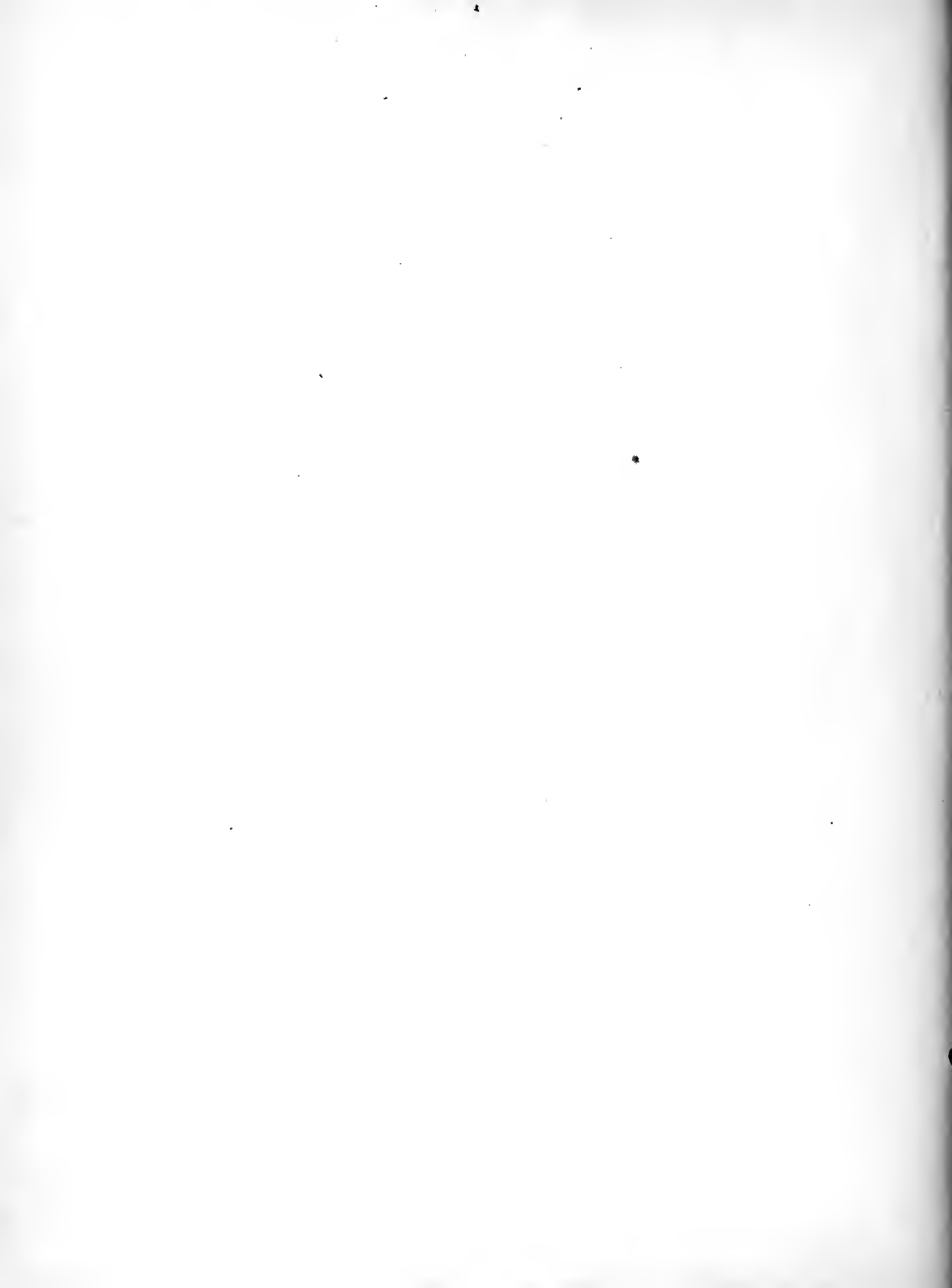
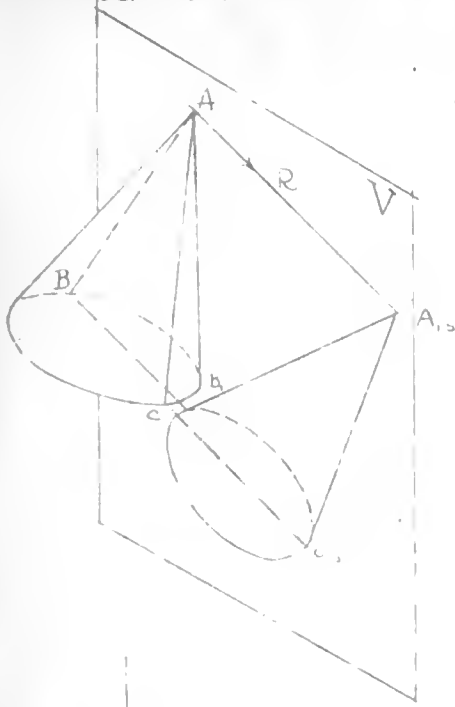

FIGURE 33



SHADES & SHADOWS

PLATE IX

By J.H. Porry, Jr.

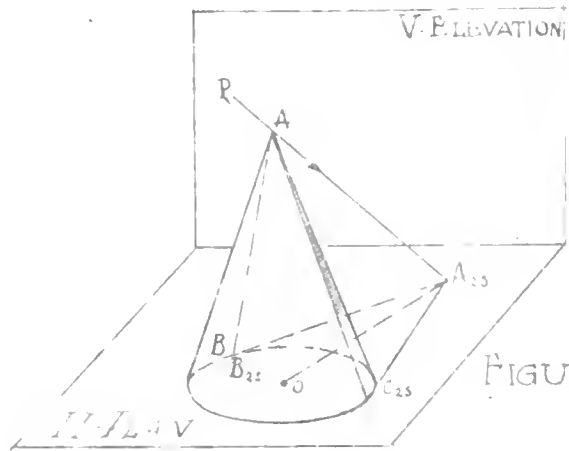

FIGURE 34

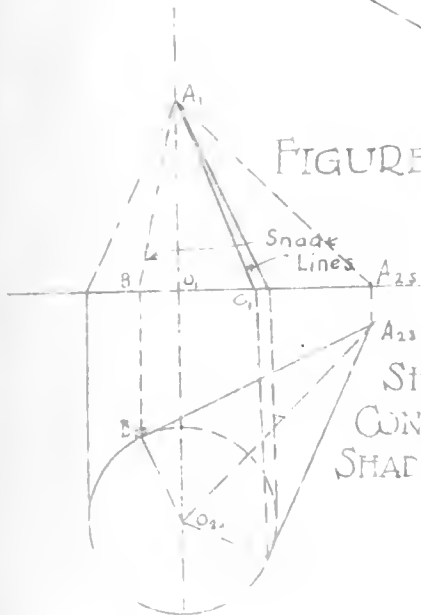

FIGURE 35

SHADE LINE ON A CONE BY USE OF SHADOW ON H PLANE.

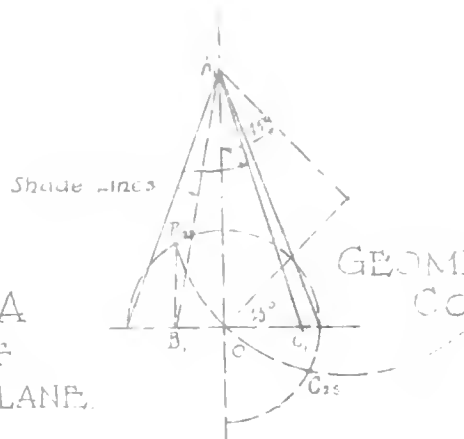

FIGURE 36

GEOMETRICAL CONSTRUCTION



FIGURE 37

AUXILIARY PLANE

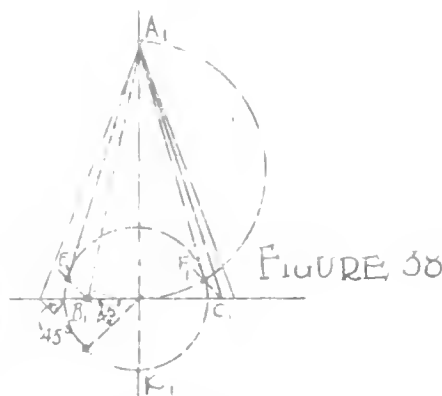

FIGURE 38

GEOMETRICAL CONSTRUCTION

SHADE LINE ON A CONE BY USE OF SHADOW ON 45°

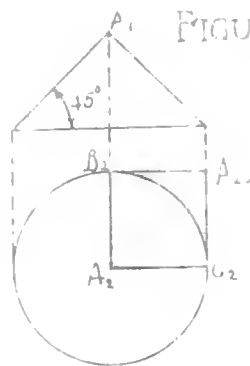

FIGURE 39

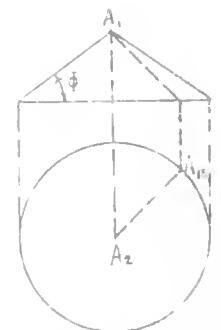
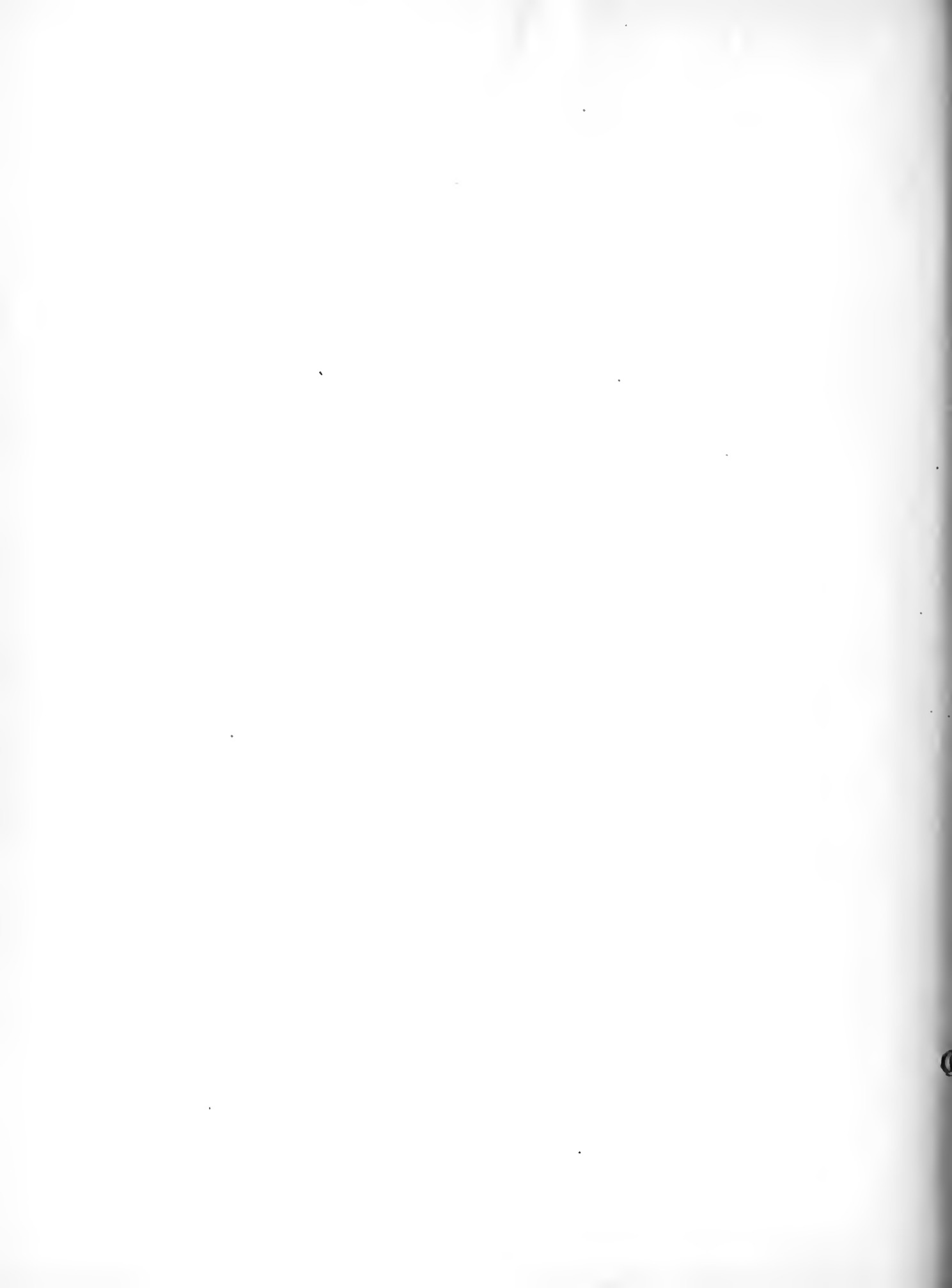

FIGURE 40



SHADES & SHADOWS

PLATE X

By J. H. Forsythe.

FIGURE 41(a)

Distance of Center of Sphere from Plane

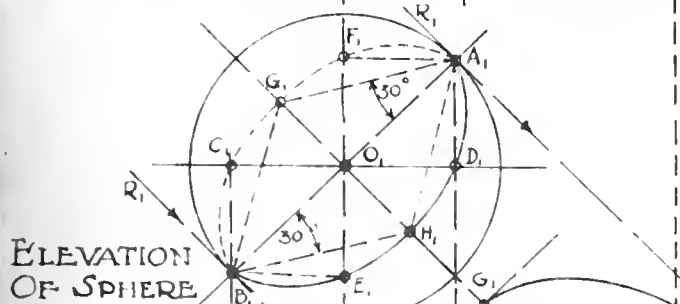

ELEVATION OF SPHERE

THE POINTS IN ELEVATION

THE POINTS IN PLAN

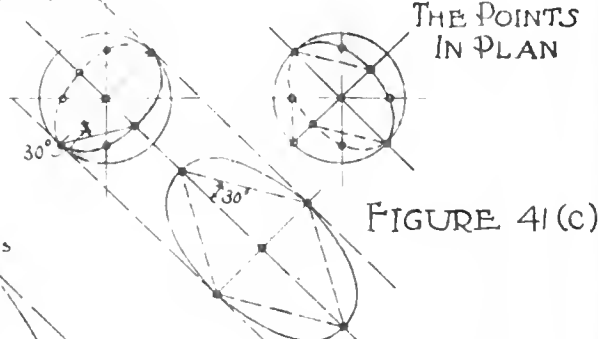
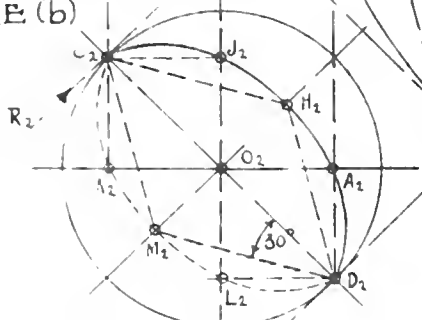

FIGURE 41(c)

THE SHADES AND SHADOWS AT SMALL SCALE

FIGURE (b)



PLAN OF SPHERE

FIGURE 41(d)
SHADOW ON V PLANE

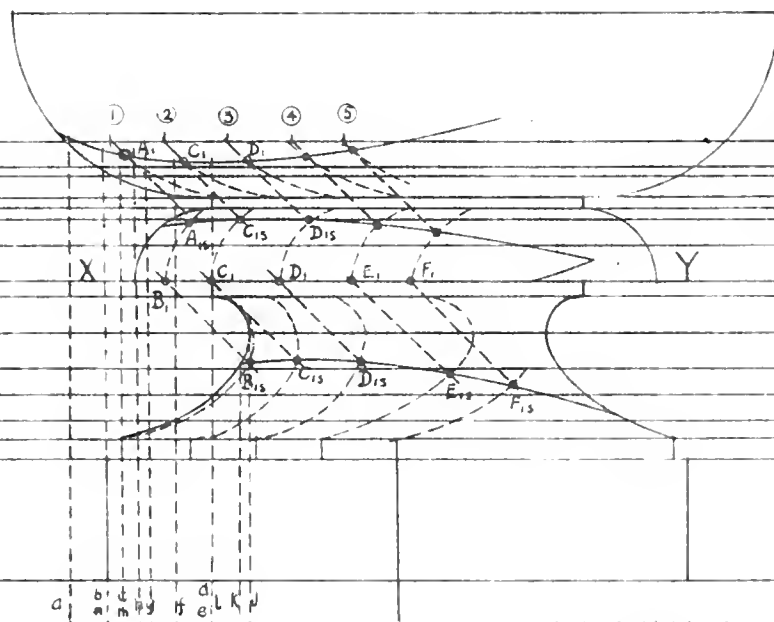
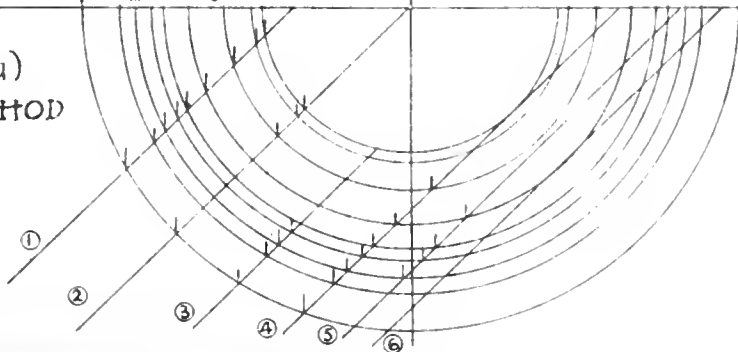
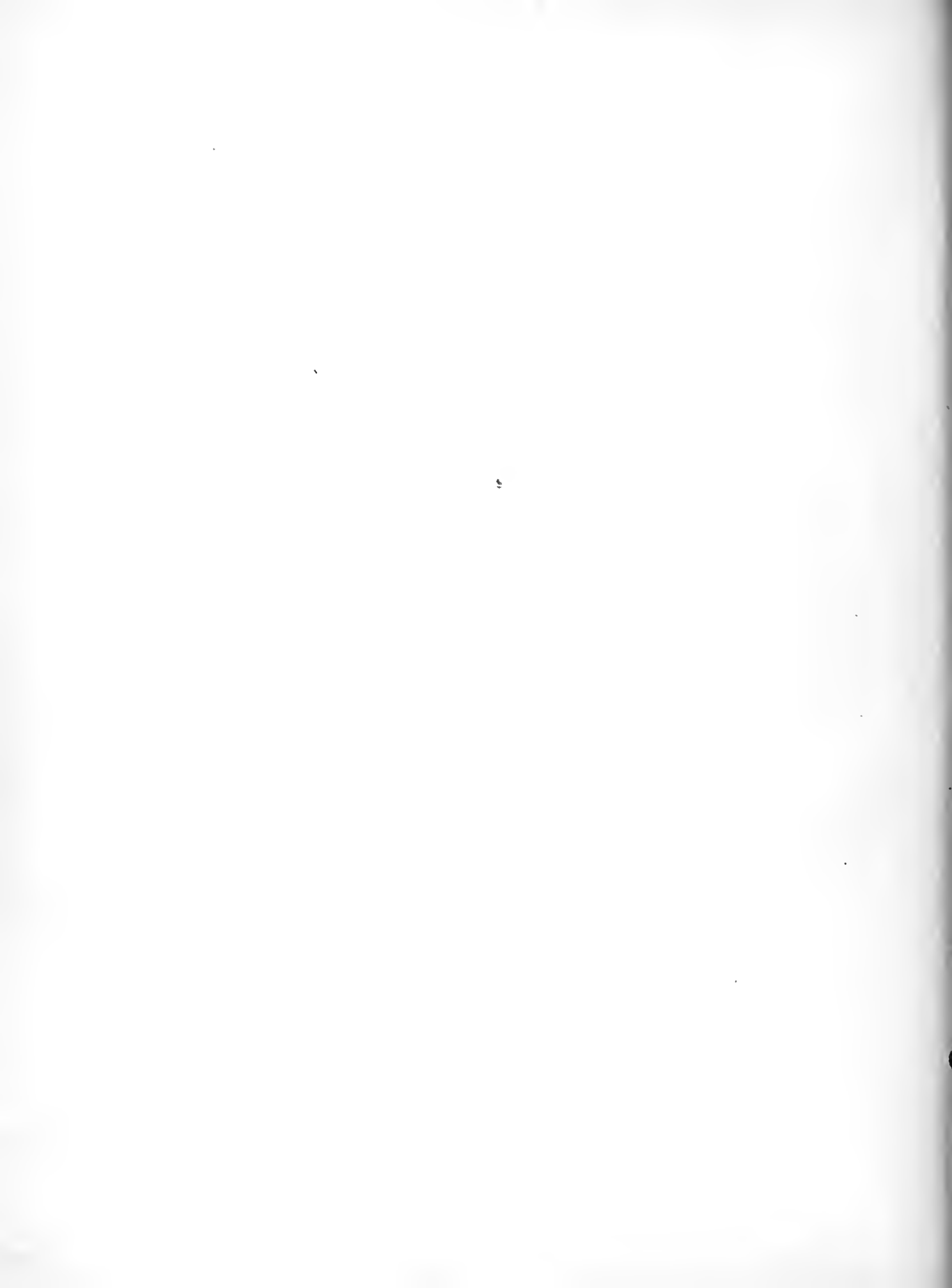

FIGURE 42 (b)

FIGURE 42 (a)
THE SLICING METHOD





THE SHADE LINE ON A TORUS
FIGURE 43

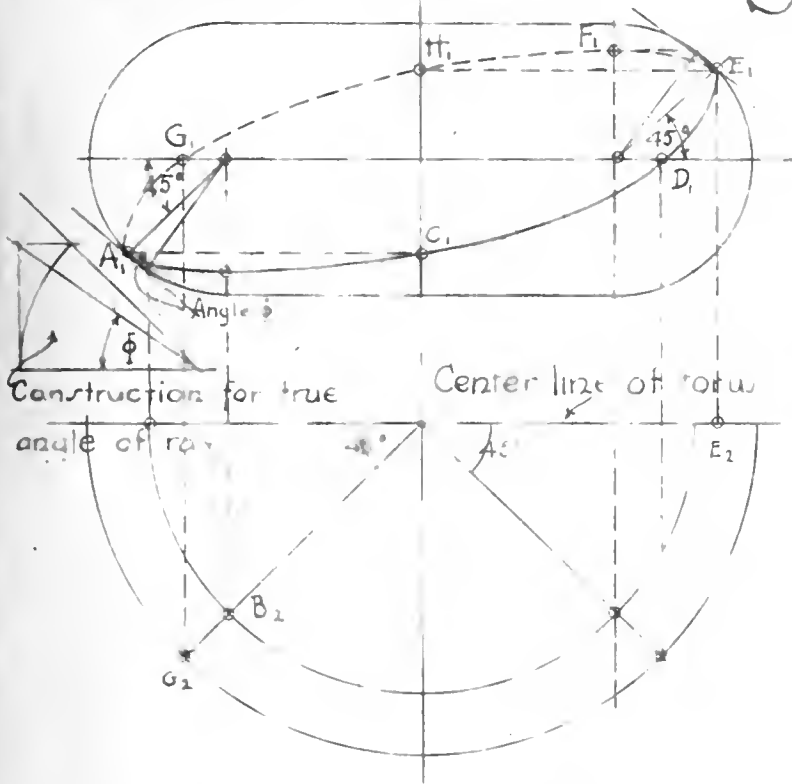

SHADES & SHADOWS

PLATE XI

By J.H. Forsythe

THE OVAL CURVE OF
THE TORUS = SHADOW
OF TORUS ON 45°
AUXILIARY PLANE

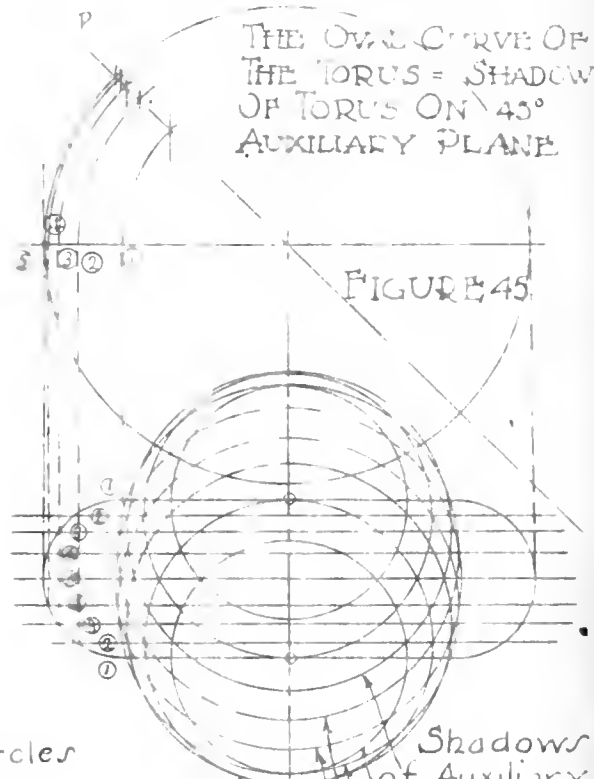

The equatorial circle of the torus

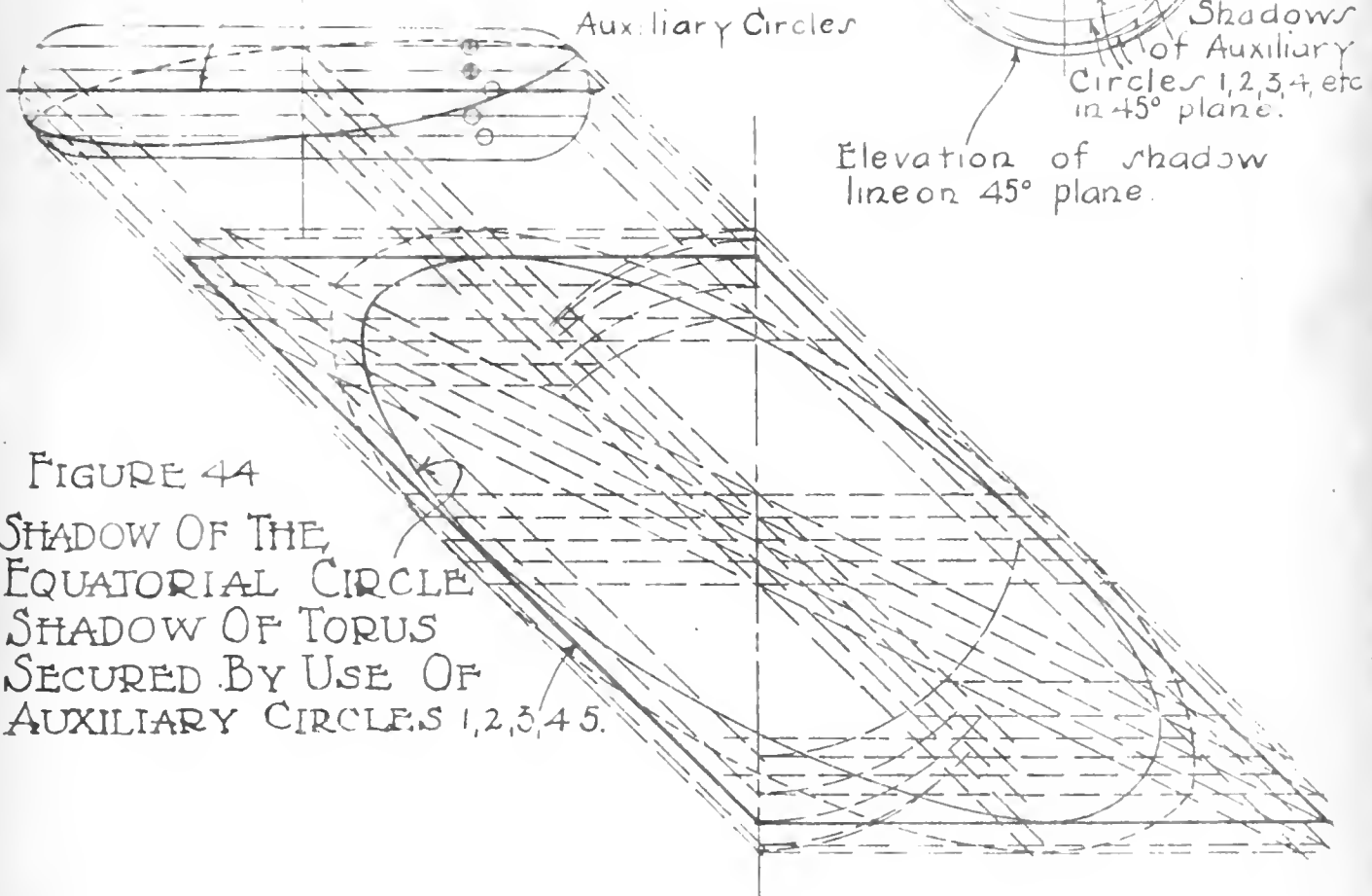
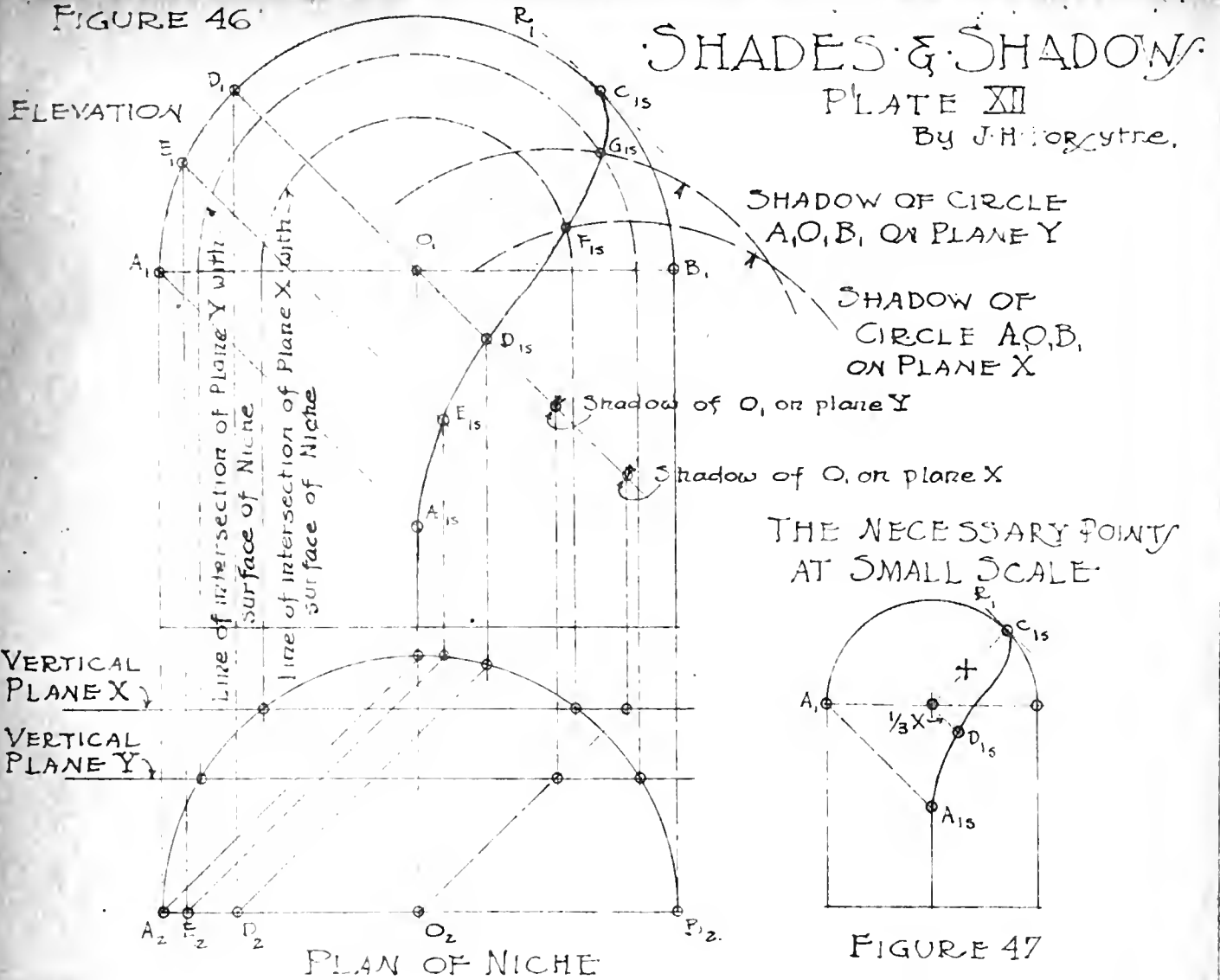

FIGURE 44
SHADOW OF THE
EQUATORIAL CIRCLE
SHADOW OF TORUS
SECURED BY USE OF
AUXILIARY CIRCLES 1, 2, 3, 4 5.

FIGURE 46



ROUND

FIGURE 48

THE SHADOWS ON THE CORINTHIAN COLUMN.

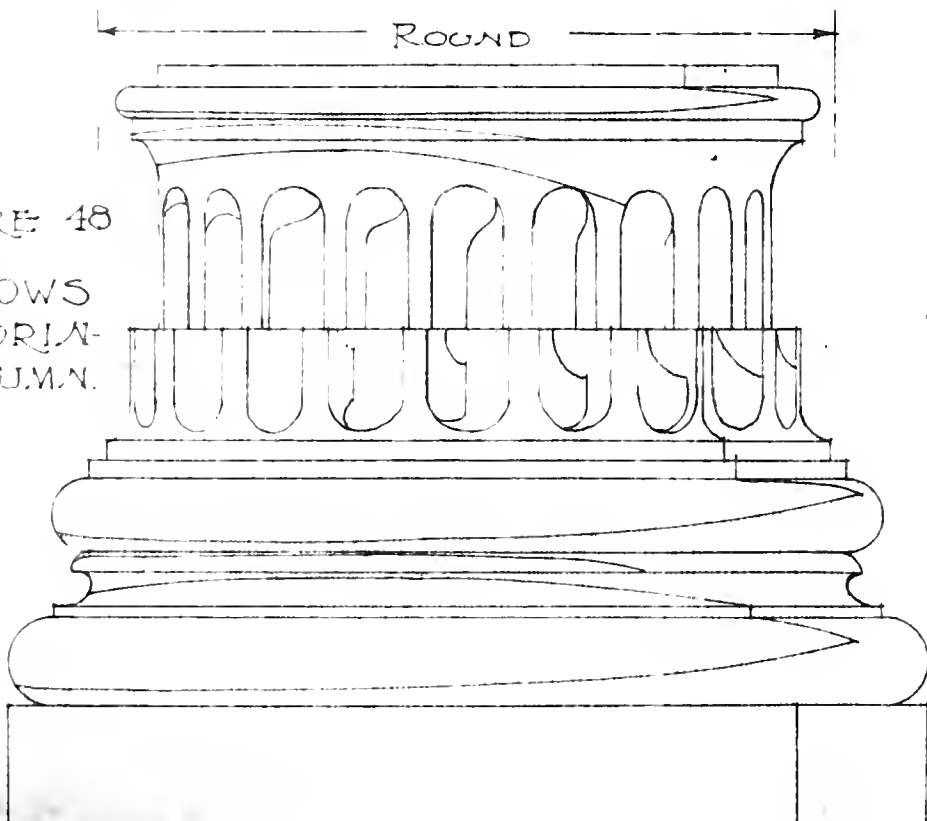

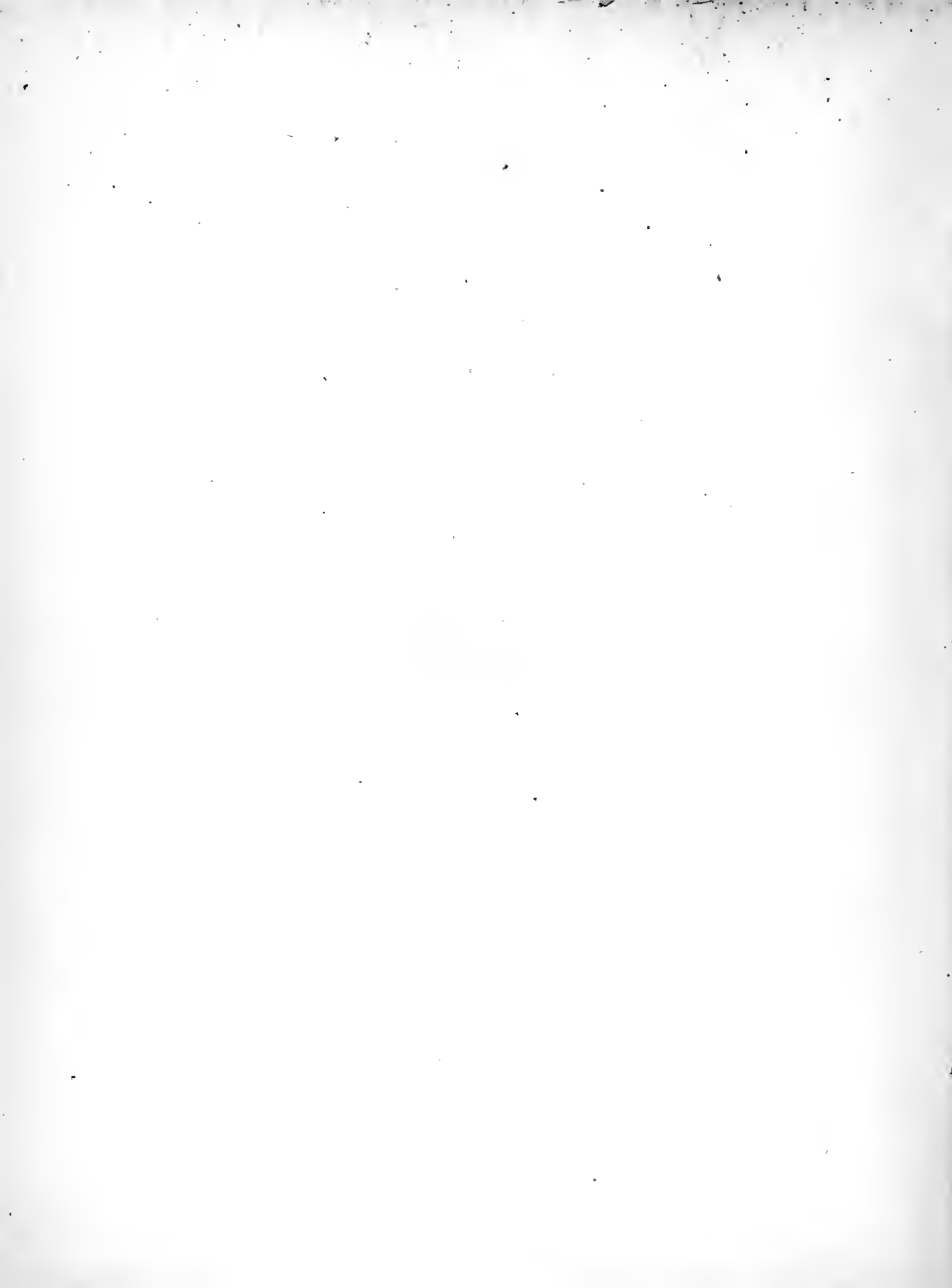



10/11/2024

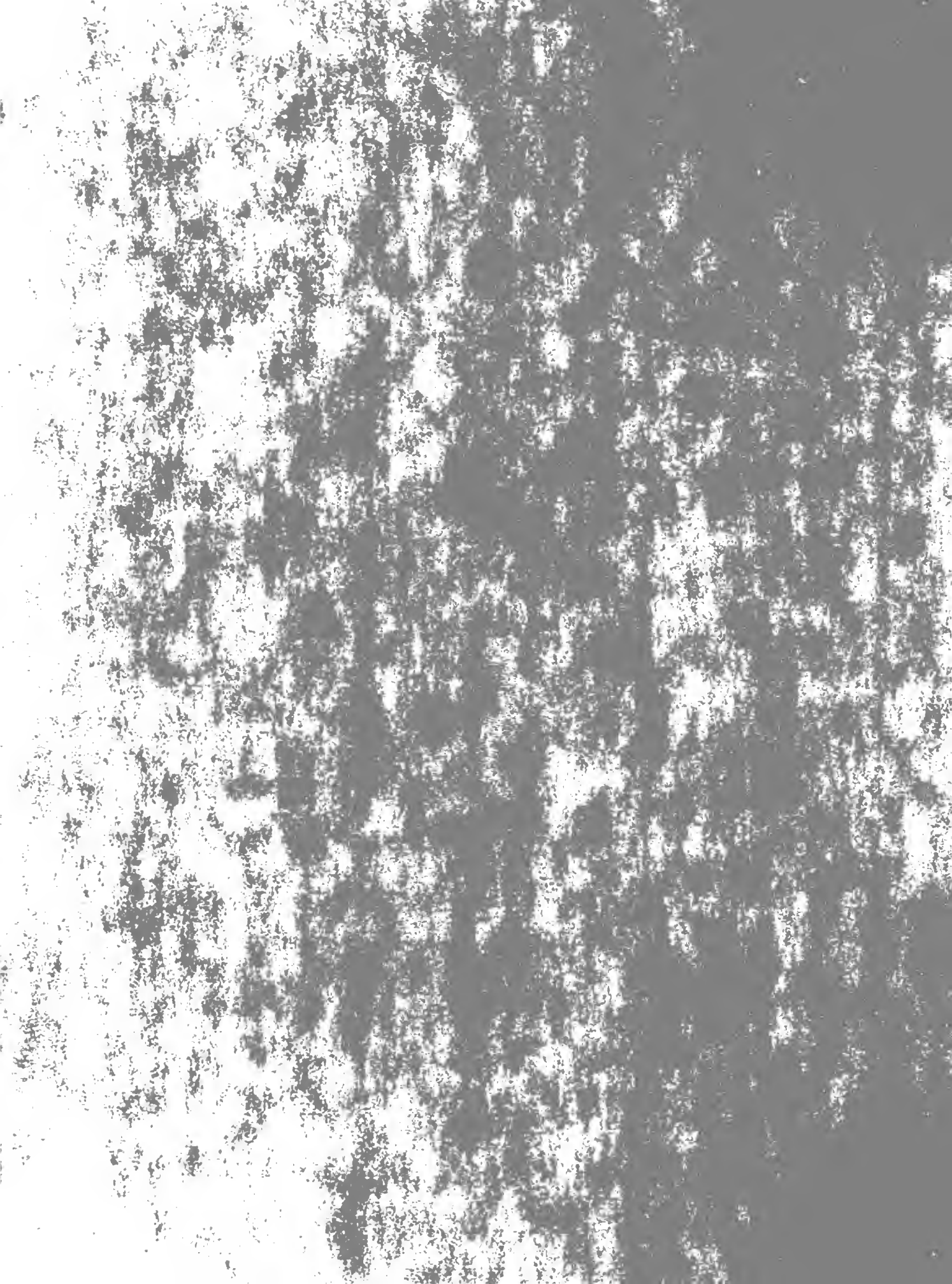

UNIVERSITY OF ILLINOIS-URBANA
Q 516 6 IL65 C001
Shades and shadows notes arranged for



3 0112 089506593