

UC-NRLF



\$B 31 960

SHALE OILS AND TARS

DR. W. SCHEITHAUER

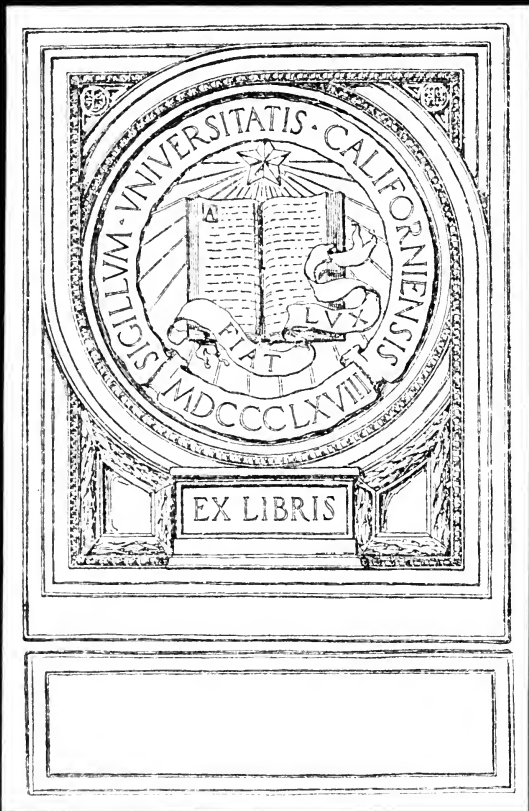

EX LIBRIS



SHALE OILS AND TARs

AND THEIR PRODUCTS

BY
DR. W. SCHEITHAUER

TRANSLATED FROM THE GERMAN

BY
CHAS. SALTER

WITH SEVENTY ILLUSTRATIONS AND FOUR DIAGRAMS

UNIV. OF
CALIFORNIA

LONDON
SCOTT, GREENWOOD & SON
8 BROADWAY, LUDGATE, E.C.

1913

[The sole rights of translation into English remain with Scott, Greenwood & Son]

D. VAN NOSTRAND COMPANY
NEW YORK

TP685
S3

TO THE
LIBRARY OF

A. I. L.

AUTHOR'S PREFACE.

THE present work is intended to depict the production and utilization of the distillation tars constituting the basis of several important industries. The chief of these are: The Scottish Shale Oil Industry and the Saxon-Thuringian Mineral Oil Industry, the latter forming a branch of the lignite mining industry of Central Germany. In addition, the production and utilization of distillation-tar is practised at Messel, near Darmstadt, Germany; and the author desires to express his cordial thanks to Dr. Spiegel, the manager of the last-named works, for the detailed description furnished by him on the methods, etc., employed there.

Bituminous tar is also subjected to dry distillation, to a smaller extent, in the south of France and in Australia, the apparatus and processes employed being adopted from the Scottish industry.

A full description is given of the apparatus of the German and Scottish industries, and of the methods of applying same, the author being engaged in the Saxon-Thuringian industry and having a personal knowledge of Scottish practice, apart from the abundant literature at his disposal.

Owing to increased official duties, the author regrets to have been prevented from completing the work himself; but

he has had the advantage of obtaining as a collaborator Dr. E. Gräfe, whose scientific researches are well known in industrial circles, and who, in addition to writing the whole of Chapters X. and XI., prepared Chapter IX. with the exception of the historical section. For this collaboration the author again tenders his best thanks.

THE AUTHOR.

WALDAU, NEAR OSTERFELD (HALLE), 1911.

TRANSLATOR'S PREFACE.

IN the German original the chief products of the distillation of both Shale and Lignite are classed as "Tar," and though, in the case of Shale this is not strictly correct, it has been considered desirable to retain this nomenclature to some extent in the translation, it being understood that the term "shale tar" is synonymous with "Crude oil".

CHAS. SALTER.

LONDON, JANUARY, 1913.

CONTENTS.

CHAPTER I.

	PAGE
HISTORY OF THE SHALE AND LIGNITE-TAR INDUSTRY	1-7

CHAPTER II.

THE BITUMINOUS RAW MATERIALS.

Occurrence	8
Origin	10
Properties and Composition	12
Working	15
Utilization	17

CHAPTER III.

THE PRODUCTION OF DISTILLATION TAR.

A. The Dry-Distillation Process	20
B. The Winning of Lignite Tar	21
The Retort	21
The Work of the Retort	27
The Condensing Plant	28
The Dry-distillation Process	29
The Distillation Plant	33
C. The Messel Tar Industry	36
The Retorts	36
The Work of the Retort	39
The Treatment of the Distillation Vapours	40
D. The Recovery of Shale Tar in Scotland	41
The Retorts	41
The Work of the Retort	50
The Condensing Plant	50
The Distillation Process	50
The Distillation Plant	51

CHAPTER IV.

THE DISTILLATION PRODUCTS.

	PAGE
A. The Tar	52
Lignite Tar	52
Shale Tar (Crude Oil)	53
Value of Distillation Tars	53
B. The Tar Water (Ammonia Liquor)	53
Lignite Tar Water	54
Shale Tar Water	56
C. Gas	57
D. The Distillation Residues	61

CHAPTER V.

THE DISTILLATION OF THE TAR AND TAR OILS.

A. The Distillation Process	64
B. Tar Distilling in the Saxon-Thuringian Industry	65
The Distilling Apparatus	65
The Distillation Process	69
The Distillation Plant	74
The Distillation Products	76
The Retorts	79
Products obtained by the Distillation of Lignite Tar (Diagrams I and II)	78, 79
C. The Messel Distillation Process	80
Apparatus for and Method of Distillation	80
The Distillation Products	80
D. The Distillation Process in the Scottish Industry	81
Apparatus for and Method of Distillation	81
Distillation Plant	83
The Distillation Products	83
Products obtained by the Distillation of Shale Tar (Crude Oil) (Diagram III)	84
Products obtained by the Distillation of Shale Tar (Crude Oil) by Classification of the various Oils (Diagram IV)	84

CHAPTER VI.

I. CHEMICAL TREATMENT OF THE TAR AND ITS DISTILLATES.

A. The Refining Process	86
B. The Refining Process in the Saxon-Thuringian Industry	87
The Agitator	87
The Refining Process	88
The Chemical Treatment of the Tar	88
Refining the Tar Products	89
Treating the Oils before Delivery	90
The Agitator House	92
C. Refining Process in the Messel Industry	92

CONTENTS

vii

	PAGE
D. Refining Process in the Scottish Industry	93
Methods	93
Chemical Treatment of the Tar Products	93

II. THE UTILIZATION OF THE REFINERY WASTE.

Uses and Treatment	94
Recovering the Chemicals	95

CHAPTER VII.

THE MANUFACTURE OF PARAFFIN.

A. The Manufacture of Paraffin in the Saxon-Thuringian Industry	98
The Crystallization Process	98
The Pressing Process	100
The Press Plant	105
The Steam Jet Treatment	106
Decolorizing the Paraffin	107
B. Manufacture of Paraffin in the Messel Industry	108
Crystallization	108
The Pressing Process	108
C. Paraffin Manufacture in the Scottish Industry	109
Crystallization	109
The Sweating Process	109
Decolorizing the Paraffin	112

CHAPTER VIII.

PRODUCTS FURNISHED BY SHALE OIL AND LIGNITE TAR.

A. Products Obtained in the Saxon-Thuringian Industry	113
Quantitative Yield	113
The Oils	113
The By-Products	119
The Paraffin	120
B. The Products of the Messel Industry	122
Yield Obtained from the Tar	122
The Oils	122
The Paraffin	122
C. The Products of the Scottish Industry	122
Yield from the Crude Oil	122
The Oils	122
The By-Products	123
The Paraffin	123

CHAPTER IX.

CANDLEMAKING.

	PAGE
Historical	125
The Raw Materials	127
(a) The Candle Material	127
(b) The Wick	130
(c) The Colouring Matters	131
The Manufacture	132
(a) The Moulding Process	132
(b) Finishing	136
(c) Packing the Candles	137
(d) Working up Candle Waste	137

CHAPTER X.

CHEMICAL COMPOSITION OF THE TARS AND THEIR DISTILLATES.

A. Lignite Tar	138
Constituents of Lignite Tar (Table)	144-145
B. Shale Tar (Crude Oil)	146

CHAPTER XI.

THE LABORATORY WORK.

Testing the Raw Materials	147
Testing the Tars and other Distillation Products	151
Testing the Tar Oils	154
Testing the Reagents used for Refining the Oils and Paraffin	157
Testing the Paraffin	158
Tests Applied in Candle Works	159
Testing the By-Products of Tar Distillation	163

CHAPTER XII.

STATISTICS.

A. The Saxon-Thuringian Industry	165
B. Statistics of the Scottish Shale Industry	174
INDEX	177-183

CHAPTER I.

HISTORY OF THE SHALE AND LIGNITE-TAR INDUSTRY.

WOOD was the first material to be subjected to dry distillation, and furnished the earliest known distillation tar, the composition of which was described by Boyle in his "Chemista scepticus" (1661). As long ago as the seventeenth century tar was recovered from the dry distillation of pine on a manufacturing scale in heavily timbered countries like Norway and Sweden.

At the same period coal was also put through a process of dry distillation. A patent (19 August, 1681) was taken out in England by Becher for the recovery of pitch and tar from coal; and this inventor was the first to produce coke¹ in addition to coal-tar. Coal is also known to have been subjected to dry distillation in Germany about the middle of the eighteenth century; but this application of coal did not attain any general importance until illuminating gas began to be made from that material early in the last century, and the employment of coal as a raw material for dye-stuffs became known towards the 'fifties—two great achievements of man's talent for investigation.

Neither of these kinds of tar, however, comes within the scope of the present work, both of them being by-products, whereas the other distillation products constitute valuable main products. At the present time tar is obtained as the main product of dry distillation by distilling bituminous lignite and bituminous shale. The distillation tar obtained from peat is also only a by-product.

Lignite tar was known, as the result of distillation experiments on a small scale, about the end of the eighteenth century, Krünitz² having mentioned in 1788 that rock oil could be obtained from Langenbogen "earth coal" (meaning lignite) by distillation. For several decades, however, no useful application was discovered for this tar, though it was occasionally used medicinally.

The discovery of paraffin in 1830 was of the greatest importance for the utilization of distillation tars; and consequently the name of the discoverer of this substance, Carl von Reichenbach, is closely connected with the history and development of the shale and lignite-

¹ This is the correct spelling. "Coak" is first mentioned in Plot's "History of Staffordshire". According to Erdmann, coke is derived from coquere (to cook).

² E. Erdmann, "Chemie der Braunkohle" ("Chemistry of Lignite"), p. 9.

tar industry. Carl, Baron von Reichenbach, was born at Stuttgart on 12 February, 1788, studied at Tübingen, and became manager of Count Salm's mines and factories at Blansko in Moravia. He died at Leipzig on 19 January, 1869.

Although other workers, like I. N. Fuchs and A. Buchner, had previously prepared paraffin, Von Reichenbach was the first to investigate this substance and to describe its chemical and physical properties;¹ and from his statement that "a wick impregnated with it burns like a fine wax candle, and without smell" it is evident that he even recognized the great economic importance of paraffin as a candle material. Von Reichenbach gave the new substance the name "paraffin" (*parum affinis*) on account of its remarkable insensitiveness to reagents. In 1830 he isolated paraffin with a melting-point of 43.75° C. from wood tar; and, by fractional distillation, he also produced a volatile oil which he named "eupion," and which apparently corresponds to lignite-tar benzol. The experiments he conducted in a highly conscientious manner were lauded by the greatest contemporary chemists. Liebig referred to them in 1833,² and one of his pupils, Ettling, analysed the creosote prepared by Von Reichenbach, whilst Gay-Lussac ascertained the chemical composition of paraffin, which he fixed as 85.2 per cent C. and 15.0 per cent H.³

Stimulated by the publication of Von Reichenbach's work on wood tar, Laurent⁴ conducted experiments on the dry distillation of bituminous shale from Autun (in the south of France), and induced Selligie to work up the resulting tar. The latter, in conjunction with De la Haye, then produced tar from this shale on a manufacturing scale, and worked it up into light oils, lamp oil, heavy oil, and paraffin ("mineral wax") which products were shown by them at the Paris Industrial Exhibition of 1839.⁵ Other distilleries and works for treating this raw material were established later, and the industry is still in existence in the south of France. The various producers there recently amalgamated to form the Société Lyonnaise des Schistes Bitumineux du Bassin d'Autun.⁶

Early in the last century peat began to be used as a raw material for dry distillation; and in the 'forties, Runge, of Oranienburg, made candles of the paraffin recovered from peat tar. His distillation process, however, was not adapted for use on a large scale, the first to invent such a process being Rees Reece⁷ (1849), who carried out experiments in collaboration with Robert Kane, and took out a patent

¹ "Journ. f. Chem. u. Phys." ("Schweigger-Seidel"), **69**, 436 (1830); **61**, 273 (1831).

² Liebig's "Annalen," **6**, 202; **8**, 216.

³ Poggendorf's "Annalen," **24**, 179.

⁴ "Chemical Technology," Vol. II, "Lighting," p. 213.

⁵ Hermann "On the Paris Industrial Exhibition," 1839 ("Industrie Ausstellung zu Paris"), p. 147.

⁶ E. Erdmann, l.c. p. 13.

⁷ Oppler, "Handbuch der Fabrikation Mineralischer Oele" ("Handbook of Mineral Oil Manufacture"), p. 6.

for the manufacture of paraffin from peat. A tar-distillation plant was put down at Kildare (Ireland), and the tar was worked up; and other works, using the same process, were also erected for utilizing the extensive Irish peat mosses.

In the 'fifties the new industry continued to grow in Austria and Germany; but it was not found possible to work at a profit in all cases, and so this method of recovering tar soon fell into desuetude.

Early in the 'nineties, Ziegler restarted the distillation of tar from the peat of the extensive mosses in the Oldenburg district, using furnaces¹ similar to those employed in the Saxon-Thuringian industry. Nevertheless the venture proved unprofitable, and had to be abandoned, as a failure, in a few years' time.²

The reason was that, as already mentioned, peat cannot be regarded as a raw material for distillation tar, it being necessary here to use as main products what are considered by-products in the actual shale-tar industry. The peat-distilling plants are really coking plants; and the utilization of peat was undertaken, from this point of view, at Ludwigshof (Ückermünde district), at the close of the last century. Peat has also been treated by the Ziegler process in Russia.³

After distillation experiments had been conducted in various countries with all kinds of raw materials, James Young took up the work in Scotland. Just as Von Reichenbach's discovery forms a landmark in the history of the distillation tars, so must Young's entrance into this industry be regarded as the second outstanding achievement. The possibility of recovering tar from bituminous shales and coal by distillation had long been known in Scotland, and a number of small distilling plants had been set up from time to time, but had only a brief existence and were of little importance. It was Young who succeeded in creating a large industry in the production and treatment of shale tar in Scotland. The founder of the Saxon-Thuringian industry, whose name forms the third landmark in this historical development, will be referred to later. James Young⁴ was born at Glasgow in 1811, and was a pupil of Thomas Graham. On the suggestion of Lyon Playfair, he built in 1848 a refinery for treating the petroleum obtained from a colliery at Alfreton. Lamp oil, lubricating oil, and small quantities of paraffin were recovered, and the latter was even made into candles. At the end of two years the supply of oil ceased, and Young sought about for some other raw material for the distillation process. Numerous specimens of English and Scottish coal were tried, without success, before he discovered, in the Boghead coal from Torbanehill, a material which furnished the desired distillation products. Young's process of dry distillation at a low temperature was

¹"Zeits. angew. Chemie," 1893, 524.

²F. Fischer, "Kraftgas" ("Power Gas"), p. 194.

³Conf. Heber On the Industrial Utilization of Peat, "Braunkohle," 8, pp. 744 *et seq.*

⁴D. R. Steuart, "The Shale Oil Industry of Scotland" ("Economic Geology," Vol. III, No. 7), p. 575.

patented in England and America; and in conjunction with Meldrum and Binney he set up distillation plant at Bathgate in 1850.

During the next ten years a number of distilleries and refineries were established in various American coast towns, to treat imported Boghead coal by Young's process, distilling the tar and oils and refining the latter with sulphuric acid and caustic soda. At the same time distillation plants were erected in Canada, to treat the Albertite oil shales mined there; and in 1860, the Lucesco Co. had ten large rotary distilling furnaces in operation.¹ However, from the year 1859 onward, the discovery of abundant supplies of petroleum in America led to the gradual closing down of the dry-distillation plants, since distillation tar could not, of course, compete with the new raw material. On the other hand, owing to the well-known adaptability of the American, the redistillation and refining plant was modified to adapt it for treating crude petroleum. This, as shown by Engler,² explains the possibility of the rapid production of lamp oil on the large scale in America, and also why the largest petroleum refineries in that country are situated in the chief ports on the Atlantic coast. The American petroleum industry mounted on the shoulders of the distillation-tar industry, and—as Steuart rightly says in his previously mentioned work—James Young may claim to be the father, not only of the Scottish shale-oil industry, but also of the great American petroleum industry.

It is quite erroneous to assume, with Müller,³ that Young's patents retarded or even injured the development of the shale-tar industry; and in fact the services he rendered that industry are proved by its extremely rapid growth in both Scotland and America. Von Reichenbach,⁴ whose happy lot as an inventor it was to see his predictions on the importance of paraffin brilliantly fulfilled, took Young's part warmly when the latter's patents were contested, and ungrudgingly recognized Young's services in having raised the shale-tar industry to a high position.

For about twelve years Boghead coal was distilled in Scotland; and then, early in the 'sixties, another well-adapted raw material was discovered in bituminous shales. Owing to the local consumption and the extensive export trade, the deposits of Boghead were almost exhausted; but a large number of new works were established to work the shale seams situated between Edinburgh and Glasgow. After having garnered the rich fruits of his labours, James Young died, full of honours, in May, 1883.

The names of Beilby, Henderson, and Steuart may be mentioned among the technical workers who contributed to the prosperity of the highly developed Scottish shale-oil industry. Many novel forms of

¹ E. Gräfe, "Braunkohle," 9, p. 424.

² W. Scheithauer, "Die Fabrikation der Mineralöle" ("The Manufacture of Mineral Oils"), p. 5.

³ "Zeits. f. Paraffin-, Mineralöl- u. Braunkohlenteerindustrie," 1876, p. 42.

⁴ "Journ. f. prakt. Chemie," 63, 64.

apparatus for the distillation of shale and the refining of paraffin are connected with the name of Henderson, the manager of the Broxburn Oil Co., Ltd. The author cherishes in grateful remembrance the cordial reception accorded to himself and friends at Broxburn in 1909, where they were welcomed, as "German colleagues," by Henderson.

The majority of the numerous works established in the course of years for the distillation of shale were, however, shut down after a brief existence. At the beginning of the 'seventies there were still fifty-one in operation, but a few years later the number had fallen to thirty. At present shale tar is recovered and worked up by six companies, further particulars of which will be found in Chapter XII.

Scottish Boghead coal was exported to Germany as well as to America, and was distilled, on the island of Wilhelmsburg near Hamburg, by Noblée & Co., in a works established by a Frenchman of that name and which had employed Wemyss coal as raw material from 1847 onward for several years. The tar was distilled, and lamp oil and paraffin were obtained therefrom. The works were subsequently removed to Harburg. A plant for distilling Boghead coal was also established in 1850 at Ludwigshafen.

At the end of the 'forties, dry-distillation plants were established in the Rhineland for treating the local coal. The first plant was built by a French firm, the Société des Schistes Bitumineux, and treated Siegburg coal under the management of H. Vohl; but the business was soon transferred to Wisemann & Co. Another works, the Augustenhütte, managed in the first place by P. Wagemann, distilled local lignite at Beuel, near Bonn, on a large scale, the tar being worked up into lamp oil, heavy oils, and paraffin. Both the workers mentioned, whose names are repeatedly encountered in the literature of the subject, conducted numerous and sometimes costly experiments for the purpose of improving the distillation apparatus. Vertical retorts were tried and experiments made with distillation in vacuo, in order to make the business profitable. Nevertheless these works—which moreover were treating an unsuitable raw material—proved unable to withstand the onslaught of the newer lamp oils from petroleum, more especially as the works themselves were damaged by outbreaks of fire; and consequently they soon had to be shut down.

Instigated by the press¹ reports on the great success of the distillation-tar industry in other countries, Scotland in particular, and by the suggestions on the importance of this industry to the Province of Saxony, with its extensive deposits of lignite, dry-distillation plants were started in the middle of the 'fifties in the classic region of the German distillation-tar industry, namely the lignite district of central Germany. Without any analytical examination of the raw material—any kind of lignite being regarded as suitable—small plants were set up in ever so many places; but most of these works, destined from the outset to failure, only lingered on for a few years. Some of them

¹Müller & Uhle, "Die Natur," 1854, No. 21.

lacked sufficient capital and experienced management. It was not until a number of pharmacists, such as Grotowsky, Schliephacke, and B. Hübner, who, in this instance as in other branches of German chemical industry, acted as the pioneer of the chemist—took up the matter from the technical standpoint, that a commencement was made with the systematic examination and selection of the raw material. At the same time a considerable amount of capital was introduced into the industry by the establishment of two large concerns, partially the result of the amalgamation of the lignite properties of a number of small owners. The oldest firm is the Sächsisch-Thüringische Aktiengesellschaft für Braunkohlenverwertung, which was founded in 1885 and built the Gerstewitz mineral oil and paraffin works. Dr. Schwarz was the first manager, and was succeeded by Dr. Schliephacke. Shortly after (in 1857) the Werschen-Weissenfelder Braunkohlen-Aktiengesellschaft¹ was established, which first confined its operations to dry distillation, and afterwards (early in 1870) started the Köpsen mineral oil and paraffin works.

Thus order and tranquillity were finally introduced into this new industry, and gave promise of a successful issue to the enterprises established on a sure foundation.

In 1858, Carol Adolf Riebeck—who was previously engaged in the mining department of the first-named company—set up his first plant for dry distillation, and soon afterwards built the Webau mineral oil and paraffin works. His name forms the third landmark in the industry, in which he played—so far as Germany is concerned—a part corresponding to that of James Young in the Scottish industry. Owing to their high spirit of enterprise, broad views, and great energy, they both succeeded in raising their respective industries to a high position. Riebeck, the son of a miner, was born at Harzgerode on 27 September, 1821, and in 1835 began to work in the mine, rising step by step until in 1852 he became mine inspector to the Sächsisch-Thüringische Co.

With untiring energy Riebeck enlarged his plant, opened up new mines, built new distilleries, enlarged the Webau works, and founded two other mineral oil works at Reussen and Oberröblingen-on-See; so that, before long, his works exceeded those of any other undertaking in size.

Among the older technical workers, an important part in the industry was played by Rolle, who was manager of the Gerstewitz works and laboured zealously between 1857 and 1860 to improve the process of dry distillation. He succeeded in replacing the horizontal retorts by a vertical pattern, the importance of which change will be discussed later on. Rolle's successor was Vogt, who was followed by Wernecke,

¹ Gruhl and Mahler, who were already connected with the industry, were associated in the foundation of this company with Reinhold Steckner, who established the banking business bearing his name at Halle-on-Saale, which important concern has ever since been closely connected with the lignite industry of central Germany.

the first to utilize the gases from the retorts for heating purposes, and assisted in a most praiseworthy manner to place this most valuable improvement in the heating of the retorts at the disposal of others.

After the death of Riebeck in 1883, his various works were taken over by a share company, the A. Riebeck'sche Montanwerke, Halle. The three mineral oil works were under the management of Krey, whose name is well known in connection with the industry. He introduced distillation in vacuo, and patented the process of distillation under pressure; and he also succeeded in carrying out Rolle's idea of utilizing the gaseous products of the distillation processes for the production of power.

In 1873 the Waldauer Braunkohlen-Industrie-Aktiengesellschaft was founded, with Schliephacke as works manager until 1898; and in 1883 the Zeitzer Paraffin & Solarölfabrik was established at Halle by the amalgamation of two concerns. The first manager of this company was Krug, who had successfully managed various mineral oil works in the same industry for a number of years previously.

Full particulars of the dry-distillation works and factories in existence at the present time will be found in Chapter XII.

Already in the 'sixties, the dry distillation of (Lias) shale had been carried out at Reutlingen in Württemberg, as described fully by Dorn.

In Australia, tar has been recovered from the dry distillation of bituminous shale, and worked up into further products, ever since 1875.

Mention may be made, in conclusion, of the youngest branch of the German distillation-tar industry, namely the treatment of bituminous coal in the works at Messel, near Darmstadt, where the working of the extensive deposits of this raw material was begun in 1885. The conversion of the mined material into paraffin and mineral oils is carried on in a large factory erected at the Messel mine.

This deposit was known as far back as the early 'sixties, but the coal was left unutilized. This is easily explained by the fact that this coal embodies the defects of other bituminous mineral treasures, its high percentage of moisture recalling ordinary lignite, whilst, in common with bituminous shales, it has a high ash content. Nevertheless, the accessibility of the material—which lies under a covering only about 13 ft. deep at most—and the known great thickness of the deposit (about 480 ft.), formed a sufficient inducement to try and overcome the difficulties in the way of treating the material.

CHAPTER II.

THE BITUMINOUS RAW MATERIALS.

OCCURRENCE.

THE chief deposits of bituminous lignite are situated in the province of Saxony, namely in the Halle mining district between the towns of Weissenfels and Zeitz, and in the vicinity of Halle, Aschersleben, and Eisleben. In addition to the bituminous material the seams contain still larger quantities of lignite poor in bitumen. The other extensive lignite deposits in central and northern Germany and also in the Rhine district contain no bituminous material or only in such small proportions that it would not pay to work. The lignite¹ is deposited in shallow basins of varying dimensions, and the thickness of the seams under the cover rock fluctuates considerably. The bituminous material is surrounded by irregularly deposited strata of non-bituminous lignite—a condition resulting from its origin. An approximate indication of a lignite deposit is afforded by Fig. 1 in which I represents the cover rock, consisting of:—

(a) Surface soil	1½ ft.
(b) Loam	6½ „
(c) Clay	50 „
(d) Sand	9½ „
(e) Sand with a layer of gravel	11½ „
(f) Clay	4½ „
	83½ ft.

II is the lignite deposit, in which the strata *g*, *i*, and *l* represent the non-bituminous material, whilst *h*, *k*, and *m* are the bituminous beds. The total thickness is 30 ft. and 18 ft. respectively, or 48 ft. in all. III is the floor of clay.

The lignite deposits are interspersed with different minerals, those most frequently observed, in addition to aluminite and gypsum, being pyrites, marcasite, and occasionally pure silica; all thoroughly permeated with carbon, and only recognizable by their weight and when burned. Mergelkalk, clay ironstone, alunite, and very rarely sulphur, phosphorite, and vivianite, are also found.

The precise characterization of the deposits of bituminous lignite

¹ Conf. Klein, "Die Deutsche Braunkohlenindustrie" ("The German Lignite Industry"), I, Section 4.

at Messel is given in Klein's previously cited work on the German lignite industry, in which the chief geological features are set forth by Dr. Steuer. Messel lignite is a mixture of bituminous clay and lignite, the organic constituents of which are chemically combined with the mineral matters. The deposit is a completely isolated one and appears to be unique in character, so far as Germany is concerned.

The superficial area of the deposit is about 240 acres, and the workings will not extend below the first 80 ft. for a very considerable time. The lignite is in beds of varying thickness and containing varying quantities of fuel. The strata overlap like the layers of an onion, and the whole deposit is of hemispherical form, embedded in an ancient depression of the surrounding formations. Consequently, a great variety of product, both in qualities and properties, is obtained in working.

The bituminous shales of Scotland,¹ like the German lignite deposits, are restricted to a small area in the vicinity of Edinburgh, about five to eight miles in width, extending from the northern shores of the Firth of Forth in a southerly direction for a distance of about sixty miles. It stretches through the counties of West Lothian and Midlothian as far as the Pentland Hills. In addition to this main deposit there are other small basins of shale, for instance in Fife.

The shale beds are 2000 to 4000 ft. below the surface, and vary in thickness between 6 ft. and 14 ft. They are embedded between calcareous sandstone strata, and the most important seams are those of Fells, Broxburn, Dunnet, Barracks, and Pumpherston. The working of these deposits was undertaken in the order given above. Formerly the largest quantity of shale treated was that from the Fells and Broxburn deposits, but at present the Pumpherston and Dunnet seams supply an equal amount.

The main deposits of bituminous shale in France² occur in the basins of Autun (Saone-et-Loire) and Buxières-les-Mines (Allier), and cover an area of about 45,000 acres. There are two distinct seams, the lower one having an average thickness of 7 to 8 ft., and the upper one about 40 in.

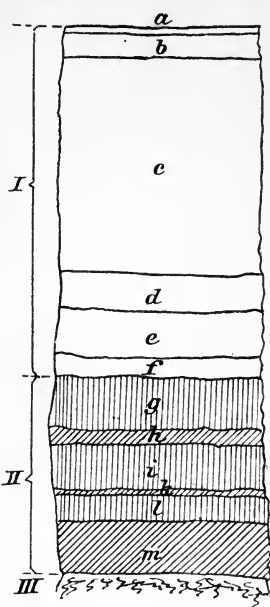

FIG. 1.—Lignite deposit; typical section.

¹ "Memoirs of the Geological Survey, Scotland," "The Oil Shales of the Lothians" (Glasgow).

² M. G. Chesneau, "Annales des Mines," 1893 (IX), Vol. III, 621 pp. *et seq.*

A material analogous to bituminous shale, and utilized for the production of tar by dry distillation, is also found in New South Wales,¹ in addition to which other deposits of bituminous shale have been identified in Victoria, South Australia, and West Australia. The largest of these extends over a large area to the west of Sydney, and contains seams of varying thickness, from a few inches to 6½ ft.

Other deposits of bituminous shales occur in French West Africa and Canada (New Brunswick) in which latter country such shale was distilled for tar in the past. Specimens of Canadian shale have recently been tried in Scotland, and gave thoroughly satisfactory results, so that there is some prospect of the industry being revived.

ORIGIN.

According to the recent investigations of Potonié and his pupils, the old theory, which obtained for a number of years on the origin of bituminous lignite, as enunciated by Von Fritsch,² is no longer tenable. Von Fritsch put forward as a general hypothesis that lignites were not formed in situ, but were silted up together, the non-bituminous lignite representing the peatified trees of the tertiary period, and the bituminous lignite the rosin and wax of that vegetation. The silting of the individual peatified layers at different times may explain the variable position of the two grades of lignite in the seams, when it is remembered that the lighter raw material of the bituminous lignite would always collect on the top. Potonié and Heinold,³ however, have advanced a very different hypothesis to explain the deposition of both kinds, and one that cannot be dismissed as without justification.

The brothers Benhardt found, at the Toma River in the sultanate of Witu (East Africa), a substance resembling pyropissit, which is the purest type of bituminous lignite. This material and its origin were investigated by Heinold, who classed it as pyropissit. Hubner⁴ had previously ascertained pyropissit to represent the transformation product of vegetable matter very rich in fat and rosin. Heinold confirmed this result by his own researches, and demonstrated—on the basis of the determinations of Heer and Friedrich—that the flora of the bituminous-lignite districts of the tertiary period contained an abundance of suitable plants and trees for the production of pyropissit. According to Friedrich, these genera are all still to be found in the monsoon districts of India.⁵

The formation of pyropissit, bituminous lignite, and therefore lignite in general, took place in the following manner:—

In the tertiary period, the lignite districts were occupied by extensive

¹ "Journ. Soc. Chem. Ind.," 24, pp. 966 *et seq.*

² "Verhandlungen des 4 Allgemeinen Deutschen Bergmannstages zu Halle," 1889 ("Proceedings of the 4th German Mining Diet," Halle, 1889), Scheithauer (l.c.)

³ "Braunkohlé," a, pp. 357 *et seq.*

⁴ "Inaugural Dissertation on the Origin of Bituminous Lignite," Halle, 1903.

⁵ "Braunkohlé," 4, 361.

swamps and bogs with a luxuriant subtropical flora. In the absence of oxygen, the dead plants and trees submerged in the swamps became converted into peat, in the same manner as can even now be observed in peat mosses.¹ The successive generations of new trees and plants growing in the mosses underwent the same transformation in their turn, until finally the swamps and mosses became choked up with more or less peatified material. A gradual accumulation of sand or clay over this stratum of peat formed the first stage of the formation of cover rock, protected the material from rotting away entirely, and established the conditions of formation of a deposit of lignite. This applies to non-bituminous lignite, whereas the conditions must have been different in the case of the bituminous type. Potonié and Heindl assume that the bituminous-lignite districts were also gradually peatified lakes with a clay bottom, the water level, however, having been subject to extensive fluctuations by alternate droughts and rainy seasons. As already indicated, the submerged vegetable matters would be converted into peat; but this fate could not befall the portions lying dry and exposed to the action of atmospheric oxygen. Of these portions, the cellulose would be entirely decomposed into water and carbon dioxide, whilst the fats and wax resins remained intact. In this way pure pyropissit was formed. If the periods of drought and submergence alternated too quickly for all the organic matter to suffer complete decomposition, a mixture of pyropissit and coal was formed, such as is found in the bituminous lignite deposits now worked. The same thing would occur at the points of transition between the formation of peat and pyropissit, owing to incomplete decomposition through restricted access of oxygen.

The alternating and variable stratification of the bituminous and non-bituminous lignites in the individual deposits can now be readily explained. The alternations of drought and submergence resulted in the formation of the two kinds in succession and in unequal quantities. The only point that is peculiar is that this phenomenon of the alternate peatification and complete destruction of the tertiary vegetable materials should have been confined to such a limited area as that represented by the bituminous lignite deposits; for the bituminous character of other lignitic deposits is evidence that plants rich in rosin and wax were also concerned in their formation.

It is necessary to assume that the bulk of the bituminous lignite was of autochthonic origin, although allochthonic action may also have contributed to a minor extent, since the occurrence of silting was by no means impossible in the tertiary period. In fact, according to Potonié,² transpositions of lignite also occurred here and there during the diluvial period, which is shown by the presence of northern flints in the open-cast workings between Streckau and Gaumnitz,

¹ Weber, "Die Entstehung der Moore" ("The Origin of Peat Mosses"), "Zeits. Angew. Chemie," 1905, 1649.

² "Braunkohle," 3, 270.

where the lignite deposit has been extensively folded by ice pressure and is interspersed with glacier drift.

Generally speaking, it may be taken for granted that the lignites belong to the tertiary system, and the bituminous kinds in particular to the Lower Oligocene.¹

The bituminous shales were formed in a similar manner to the bituminous lignites, except that in their case the bituminous material was furnished by the remains of animals as well as plants. The shales must be regarded as having been deposited in a perfectly quiescent sea.² The imprints of marine animals on the Scottish shales indicate that these shales were deposited in deep water, probably in a quiet bay abundantly populated with animal life, and therefore with a luxuriant flora. The remains of dead animals and plants were carried down with the mineral deposits from the sea water, and in their decay furnished bitumen. From the highly varying thickness of the bituminous shales, the bitumen content of which alone makes it profitable to work, it would appear that a large number of marine animals perished on certain occasions, probably as the result of volcanic outbreaks, the Scottish shale deposits having been shown to belong to the volcanic region.

Although Potonié³ regards such catastrophes as subordinate phenomena in the formation of ooze rocks, he nevertheless does not rule them out altogether.

As the same author has shown,⁴ the raw material of the Australian industry, the bitumen of the kerosene shale, is of vegetable origin and owes its formation to the oleaginous algæ, being a fucoidal coal and not a true shale.

The concomitant fossils in Messel bituminous coal indicate a joint animal and vegetable origin.⁵

PROPERTIES AND COMPOSITION.

The bituminous and non-bituminous lignites won from the seams, are raised to the surface, and in this condition contain 50 to 60 per cent of moisture and are very difficult to differentiate except by an expert. The freshly raised bituminous lignite forms a plastic and occasionally greasy mass of brownish black colour; but when dried is yellow to light brown, with an earthy fracture and dull lustre which changes to a greasy sheen under the action of rubbing against a smooth surface. The non-bituminous variety becomes black or light brown in colour when dried, and its specific gravity is 1.2 to 1.4, as compared with 0.9 to 1.1 for the bituminous lignite. In contrast to the former, this latter melts on ignition, and burns with a very smoky flame.

¹ E. Erdmann ("Classification of Lignites") "Braunkohle," 6, 394.

² Carl Dorn, "Der Liasschiefer" ("The Lias Shales"), p. 9.

³ "Zur Frage nach den Urmaterialien der Petroleum" ("Origin of Petroleum"), p. 355.

⁴ *Ibid.* p. 357.

⁵ According to Dr. Spiegel.

This property is exhibited in a special degree by the purest variety, namely pyropissit, the deposits of which, however, are now completely exhausted, though it is occasionally found interspersed in small quantities throughout the seams of lignite.

The most important constituent of bituminous lignite is the bitumen,¹ which determines its value. The formation of this bitumen has already been discussed. The bulk of the bitumen contained in lignite can be extracted by means of solvents,² like benzol, toluol, ether, acetone, alcohols, carbon disulphide, and carbon tetrachloride.³ The amount and character of the bitumen recovered in this way depends on the solvent used. This method of extraction forms the basis of the technical utilization of bituminous lignite in the preparation of mineral wax, which will be dealt with later. The purest type of this lignite, pyropissit, naturally contains the highest proportion of bitumen.

Numerous analyses have been made of pyropissit, including those by Schwarz and E. Riebeck,⁴ and the more recent researches by Krämer and Spilker,⁵ Hübner,⁶ and Erdmann.⁷ Krämer and Spilker, in addition to sulphur, detected the presence of high-molecular monacid esters and the free acids of same, but no glycerides or polyvalent carboxylic acids could be found. Hübner found two ketones, with the composition $C_{16}H_{32}O$ and $C_{12}H_{24}O$ and a humic acid containing 8.39 per cent of sulphur. Gräfe⁸ could only find a far smaller amount of sulphur (1.68 to 4.9 per cent) in the humic acids isolated from bituminous lignite, thus showing that the sulphur content varies considerably according to the original material.

E. Erdmann⁹ analysed pyropissit, bituminous lignite, and the non-bituminous kind. The results are given in the following table:—

No.	Kind.	Origin.	C.	H.	O(N) (diffce.).	S (volatile).	Ash.
1	Pyropissit.	Köpsen, nr. Weisenfels.	71.12	11.63	9.43	0.10	7.72
2	Bituminous lignite.	Waldau, nr. Osterfeld.	64.83	7.62	19.18	0.48	7.89
3)	Earthy, non-bituminous lignite. {	Waldau, nr. Osterfeld.	62.15	6.42	22.11	0.46	8.86
4)		Greppin.	58.36	4.88	23.95	1.41	11.40

On being subjected to dry distillation in the moist condition as

¹ Scheithauer ("Lignite Bitumen"), "Braunkohle," **3**, 97.

² Gräfe ("Bitumen and Retinite"), "Braunkohle," **6**, 217.

³ "Chem. Eng.," 1910, **12**, 15.

⁴ Scheithauer, "Die Fabrikation der Mineralöle" ("Manufacture of Mineral Oils"), p. 18.

⁵ "Berichte," 1902, **12**, 15.

⁶ "Inaugural Dissertation," Halle, 1908.

⁷ "Die Chemie der Braunkohle" ("Chemistry of Lignite"), p. 66 *et seq.*

⁸ "Braunkohle," **3**, 242.

⁹ "Die Chemie der Braunkohle," p. 72.

raised from the pit (about 50 per cent of moisture), Nos. 1 to 3 gave the following yield :—

	1	2	3	
Tar ¹	32.61	18.75	8.88	per cent ²
Coke	10.33	20.83	28.88	„
Gas	7.06	10.42	12.24	„

The sulphur content of bituminous lignite varies, and is seldom below 1 per cent in the lignite as raised.

Pyropissit contains only small traces of plant remains, such as pollen and cell tissue, but in point of ash content it differs little from bituminous lignite. The ash is partly attributable to the inorganic constituents of the plants from which the lignite was formed, and in part to matter deposited from the water of the swamps. The gypsum and ferruginous matters in the water that subsequently permeated the lignite deposits, have also contributed to the ash content.

The following basic constituents have been found in lignite ash : oxides of iron, aluminium, and calcium, and to a smaller extent, of magnesium, potassium, sodium, and (occasionally) manganese, with traces of strontium. The acids present include silica, sulphuric acid, sulphurous acid (with thio-sulphuric acid occasionally in the flue ash), sulphuretted hydrogen, carbon dioxide, traces of hydrochloric acid, and (occasionally) phosphoric acid.

As a fertilizer, the ash of lignite has no particular value, though it loosens the soil in an advantageous manner. The following analysis of a lignite ash is given by E. Erdmann :—

Calcium sulphide	0.46 per cent.
Iron sulphide	1.38 „
Calcium sulphite	1.12 „
Calcium thiosulphate	1.27 „
Potassium sulphate	1.26 „
Magnesium sulphate	7.65 „
Calcium sulphate	26.68 „
Calcium hydroxide	15.13 „
Lime, combined with carbonic acid and silica	11.85 „
Ferric oxide and alumina	9.70 „
Carbon	1.66 „
Silica	17.79 „
Carbon monoxide and water	4.96 „
	100.91

Messel coal is lumpy and of a semi-clayey character, cuts something like Dutch cheese, is blackish-green in colour, and exhibits a conchoid fracture when dry. When exposed to the action of frost and afterwards thawed out again, it splits up into innumerable sheets as thin as paper, from which one may conclude that, on account of its high geological antiquity, and had the contained water been forced out by pressure, it might have furnished a bituminous shale. The mois-

¹ These are laboratory results. On the large scale the yield would be about 60 per cent.

² As a rule, the yield from non-bituminous lignite is smaller, and is found in the laboratory to be about 6 to 8 per cent.

ture content runs up to 45 per cent, and the ash averages 30 per cent. As it thus contains only 25 per cent of combustible matter, its calorific value is correspondingly low and would not pay the cost of carriage for heating purposes.

When subjected to dry distillation in the laboratory, an average sample furnishes: moisture 44 per cent, water of decomposition 6 per cent, crude oil (lignite tar) 7·8 per cent, coky residue 36 per cent, gas 6·2 per cent. The water of decomposition contains a considerable amount of volatile and fixed ammonia salts, together with pyrocatechin and its homologues. The fixed ammonia salts are combinations of a whole series of fatty acids. The residual coke contains on the average 21 per cent of carbon, but its ash content is attributable to clay rich in ferric oxide.

Scottish bituminous shale, or oil shale, is black, brown, or even grey in colour, the richest in bitumen being the darkest. It is sticky and of low flexibility, can be scraped, and exhibits a conchoid fracture. The structure is decidedly foliaceous, especially after distillation. The specific gravity varies between 1·713 and 1·877. In contrast to bituminous lignite, the bitumen cannot be even partially extracted by solvents.¹ The average yield from good shale on distillation is:—

Water	2·68 per cent.
Tar	24·31 "
Residue	73·00 "

the last named being composed of 12·5 per cent of carbon and 60·5 per cent of ash. The spent shale from the new-pattern retorts contains far less carbon than that from the older types, namely only about 3 to 4 per cent as compared with as much as 18 per cent of carbon in some cases. According to Redwood² the residue consists of:—

Carbon	3·61 per cent.
Silica	56·49 "
Ferric oxide	12·81 "
Alumina	22·72 "
Lime	1·77 "
Magnesia	0·95 "
Sulphur	1·15 "

The shales distilled in the south of France give an average yield of 5 to 6 per cent of tar.

The Australian shale, on the other hand, yields up to 60 per cent of tar, but this is poor in paraffin.

WORKING.³

The extent and position of a lignite deposit having been proved by numerous borings, the method of developing and working depends

¹ D. R. Steuart, "The Shale Oil Industry of Scotland," p. 557.

² "Mineral Oils and their By-products."

³ Vollert, "Der Braunkohlenbergbau im Oberbergamtsbezirk Halle," etc. ("Lignite Mining in the Halle District"), pp. 149 *et seq.*; Klein, "Die Deutsche Braunkohleindustrie" ("The German Lignite Industry") II.

on the relative thickness of deposit and cover rock. If this proportion be 1 : 1 or less, the deposit is worked on the open-cast system, the cover rock being removed by hand or machinery. Since efficient steam navvies have been available, the open-cast system is adopted even where the said proportion rises to 1 : 1½ or even 1 : 2, provided the thickness of the deposit is not very small. It is merely a question of calculation.

The lignite is mostly raised from these open-cast workings by haulage inclines operated by chains or ropes; and only by shaft winding in workings of no great extent.

Shaft mining is practised when the thickness of the cover rock exceeds that of the deposit considerably, as shown in Fig. 1. Most of the bituminous lignite deposits supplying material for dry distillation, with the exception of a few open-cast workings, are worked in this way, whereas open-cast is the rule in the Lausitz and Rhenish lignite districts.

The shafts sunk down to the deposit are for the purpose of winding and ventilation. The process is a difficult one, especially where quicksand strata have to be traversed; and forms the chief task in developing a deposit. In the bituminous lignite district, the shafts are rarely more than 66 yds. in depth, though a few reach 82 yds. or more.

From the bottom of the shaft, main haulage roads (double roads with two lines of tracks for the pit tubs) are driven transversely through the deposit in various directions. These roads branch off at right angles into single-track branch roads, at certain intervals (depending on local conditions), these secondary roads running right out to the boundary. The lignite is won by hewing down the upper part of the seam for a height of about 13 ft. at the end of the branch roads, and keeping the opened space clear by means of props and timbers. When the worked-out space measures 20 to 30 sq. yds. in area, the timbers are withdrawn and the cover rock is allowed to cave in (subsidence working). The adjoining pillars of lignite are worked in a similar manner, until the whole of the lignite has been won. As the deposits are generally thicker than the 13 ft. mentioned, the fallen roof is allowed to lie and consolidate for some time, after which the lower lift of the seam is worked in precisely the same way as the upper one. In some cases there are even as many as three or four lifts, since many seams are 13 to 18 yds. thick; and indeed, thicknesses of 80 yds. or more are not uncommon in deposits worked on the open-cast system.

The haulage tubs used in both open-cast and shaft mining are of wood or sheet iron and hold about 13 to 16 bushels, less frequently 19 to 22 bushels. For short distances these tubs are run by hand labour, endless-chain or wire-rope mechanical haulage being employed for longer distances. In shaft winding, an engine drives a cylindrical rope drum by means of pinion gearing. Suspended from the rope are the cages in which the full tubs are raised to the surface and the empties lowered into the pit again.

Where the distance from the pit to the classifying plant is small the

lignite is transported in the tubs or else by belt conveyors, aerial rope-ways being used for longer distances.

In order to separate the bituminous coal from the non-bituminous, samples of the lignite obtained during the trial borings must be analysed, so that the hewers may know whereabouts the bituminous material is to be found. Assistance in this respect is also afforded by certain practical knacks, which, however, cannot replace chemical analysis and control; and it is important that, so far as is possible, only bituminous lignite should be sent to the distillation plant.

At Messel, the coal is won by open-cast working, with haulage roads underneath, the tubs running down by gravitation and being raised by a system of chain haulage. The haulage devices and extensive classifying plant are operated in part by shafting driven by small gas engines, and in part by electromotors deriving current from a central power house served by large gas engines.

The shale beds in Scotland not only vary considerably in thickness, but are also situated at different depths, and contain a number of seams.

Before beginning to work, the position of the shale seam must be accurately ascertained by borings. The cores obtained are tested for the suitability of the material for dry-distillation. The beds are worked¹ either by means of vertical shafts, or else, if the seams pitch, from adits driven from the surface down to the seam and serving as rope-haulage roads. The deposit is opened up by driving cross headings, in which the shale is won by blasting so as to bring it down in the largest lumps possible. For this purpose gunpowder is used, dynamite being only employed occasionally in damp places. The shot firing is performed in accordance with well-defined governmental regulations.

The shale is hauled by means of tubs and a ropeway to the distilling plant.

UTILIZATION.

In considering the utilization of bituminous lignite, it is desirable also to treat briefly that of the other grade of lignite, which contains only small quantities of bitumen. This non-bituminous or burning coal is used solely for heating purposes, and is either sold in the condition of "through-and-through" coal, i.e. exactly as it comes from the mine, or else separated, by screening, into small and large. The large is again graded for sale, whilst the small is made up into compressed blocks, shaped like bricks, and prepared by subjecting the moist smalls to a pressure of 5 to 7 atmospheres in a press. The manufacture is carried on during the summer, because the finished blocks have to be dried in the air, and artificial drying machines have not yet proved altogether satisfactory. These blocks are sold for domestic heating purposes in the vicinity of the works, being too crumbly to stand any long carriage by rail.

The production of lignite briquettes forms the main application of non-bituminous lignite, and one that is increasing every year. These.

¹ "The Oil Shales of the Lothians."

briquettes are made by crushing the freshly mined lignite to the size of peas, followed by drying until the moisture content has been reduced to 12 or 16 per cent, whereupon the mass is subjected to a pressure of 1200 to 1500 atmospheres, the heat of which operation softens the contained bitumen and binds the particles of lignite to a solid mass. Contrary to the practice in making briquettes of ordinary coal, no binding medium is added. It is evident that this application of the lignite is due entirely to the bitumen it contains.¹

Owing to its high bitumen content the bituminous lignite is unsuitable for fuel or for the manufacture of briquettes, since in the former case a portion of the molten fuel would drop through the grate, corroding the firebars and having only a low-heating effect, whilst in the second contingency, experience has shown that the briquettes crumble and fall to pieces in the fire.

For some decades bituminous lignite has been used as a material for the dry-distillation process; which process, and the working up of the resulting lignite tar into mineral oils and paraffin, constitute the sphere of the Saxon-Thuringian mineral oil industry and will be described in subsequent chapters.

A second application of bituminous lignite consists in the recovery of its bituminous contents, these being separated from the carbonaceous portions by the aid of solvents. The possibility of such separation had long been made known by laboratory experiments; and the previously mentioned investigations of pyropissit were based thereon. The first to recover this bitumen on a manufacturing scale was Von Boyen, who took out a patent for his process;² and at the present time crude bitumen is extracted from bituminous lignite in about six different works. As a rule the lignite is crushed (but not to dust) and dried before being extracted;³ the only process in which the bitumen is treated in the damp state in which it is raised from the mine being that of Frank and Ziegler ("wet extraction"). Benzol is generally used as the solvent.

The extracted lignite still contains enough bitumen to enable it to be briquetted;⁴ and it also finds application in fuel.

The crude bitumen thus obtained is usually termed "mineral wax," although Von Boyen wished to apply this term to the refined product prepared by subjecting the crude bitumen to repeated distillations with superheated steam. The crude bitumen is black, whereas the refined product has a wax-yellow colour. Various methods, some of them patented, have been introduced for lightening the colour of the crude bitumen without altering its composition; a result that would be of considerable value in connection with its employment and utilization. So far as the author is aware, however, none of these methods has been attended with practical or economic success.

¹ Scheithauer ("Lignite Bitumen"), "Braunkohle," 3, 101.

² "Zeits. Angew. Chemie," 1901, 1110; Ger. Pat. 101, 373; 116, 453.

³ Gräfe, "Braunkohle," 6, 219.

⁴ Scheithauer, "Braunkohle," 3, 101.

Bitumen is of little use as a material for candles ; but on the other hand it forms in many cases a substitute for Carnauba wax, which it also resembles in its chemical properties. It is also used as an insulating material, in the preparation of shoe polishes and varnishes, and as a raw material for phonograph cylinders.

The sale of mineral wax is naturally but small, and there is little prospect of any considerable increase in the output, which at present amounts to about 400 to 500 tons per annum.

Since the best grades of bituminous lignite are already exhausted, and a good quality raw material alone is suitable for the production of bitumen, the further development of the industry is also restricted on this account.

At the Messel works, the coal raised is all worked up in the dry-distillation plant. At one time the output was graded, but now the whole of the coal is sent to the distillation plant. The yield of tar varied between 4 and 14 per cent when the grades were distilled separately ; but that from the through-and-through coal averages about $7\frac{1}{2}$ per cent. Only very small quantities of bitumen can be extracted from this coal.

The Scottish bituminous shale also is used exclusively as a raw material for dry distillation, it being, as already mentioned, impossible to recover the bitumen by extraction. If the term bitumen were restricted to such constituents as can be extracted from the bituminous raw materials by solvents, then Messel coal and Scottish oil shale would have to be excluded from that category. As the author has previously explained elsewhere,¹ the best comprehensive definition of "bitumen" is the substances which furnish tar when subjected to dry distillation. The circumstance that cellulose also must be included if we pursue this theory further, as was done by Erdmann,² is no objection, when it is remembered that part of the tar from lignite is formed from the ligneous matter. When cellulose is allowed to rot, it decomposes in the same manner as in dry distillation, the carbon and hydrogen being dissipated as carbon dioxide and water vapour, leaving only the raw material of tar—bitumen—behind.

The French and Australian shales are chiefly used for the production of tar, though in the latter country the richest shale is also used as an adjunct to coal in the manufacture of gas,³ and a portion of the output is even exported abroad.

¹ "Braunkohle," 3, 101.

² "Die Chemie der Braunkohle" ("The Chemistry of Lignite"), p. 77.

³ "The Petroleum Gazette," 1908, No. 4, p. 5.

CHAPTER III.

THE PRODUCTION OF DISTILLATION TAR.

A. THE DRY-DISTILLATION PROCESS.

To obtain tar from the bitumen of the raw material, the latter must be distilled. Appliances of highly divergent character have been used for this purpose at different times; but the object kept in view in all cases has been to prevent the decomposition of the bitumen from proceeding further than was necessary to furnish tar as the main product, and to obviate the formation of decomposition products of tar.

The most important point is the heating of the retorts; and experiments must be made to ascertain the most suitable temperature for ensuring the proper distillation of a raw material in a given apparatus. If the temperature be too high, the tar vapours are decomposed, more gas is liberated, and a portion of the solid hydrocarbons will be converted into volatile substances rich in aromatic compounds, like benzol and its homologues, naphthalene, etc. The gases contain an abundance of free hydrogen and light hydrocarbons. If the distillation temperature be too low, the bitumen is not completely decomposed, but is carried over with the tar. The liquid and solid distillation products are then free from aromatic hydrocarbons, and consist solely of hydrocarbons of the fatty series, the higher homologues of methane and ethane, whilst the gases consist mainly of heavy hydrocarbons, like ethylene and acetylene. Moreover, the residue is far richer in carbon than in the former case. A properly selected temperature just decomposes the bitumen, without splitting up the tar any further; but, of course, this ideal cannot be uniformly attained in practice. Nevertheless, endeavours should be made to realize it as completely as possible.

It is also important that the distillation process should be conducted in such a manner that all parts of the raw material are exposed to a uniform heat in the several stages of the operation. The retort and the fire for heating same must be so constructed and arranged that the material is heated gently at first, the temperature being raised gradually, and finally becoming sufficiently high to decompose the final traces of the bitumen and convert them into tar. These conditions are thoroughly fulfilled in the modern patterns of retort.

In contrast to the practice in Scotland, the distillation of the raw material in the Saxon-Thuringian industry is effected without the use of steam. Towards the end of the 'sixties, Ramdohr tried to employ steam as an auxiliary in the dry distillation of lignite, using it first

in the horizontal retort and afterwards in the vertical pattern.¹ The method, however, did not succeed in practice, and was only used experimentally for a short time. Ramdohr termed the resulting product "steam tar," and it differed essentially from that obtained by the ordinary dry-distillation process, inasmuch as it contained considerable quantities of bitumen which was protected from decomposing by the steam, whereas it is the decomposition products that are desired in this tar.

As already mentioned, steam is used in the Scottish shale industry, the apparatus being constructed accordingly. This treatment is necessary, because ammonia is recovered from the aqueous distillate. A full description will be given later.

In the Scottish industry the process must be conducted in such a manner that a high yield of ammonia, as well as tar, is obtained from the shale; and this result is most completely achieved with the newest retorts.²

After the distillation process has been completed at a low temperature, steam is allowed to act at a high temperature on the spent shale.³ This causes the carbon of the shale to be converted into a mixture of carbon monoxide and carbon dioxide, whilst the resulting hydrogen unites with the nitrogen of the shale to form ammonia.

B. THE WINNING OF LIGNITE TAR.

The Retort.

The earliest kind of retort used in the Saxon-Thuringian industry was horizontal, in the form of a  of cast iron. This pattern was used by

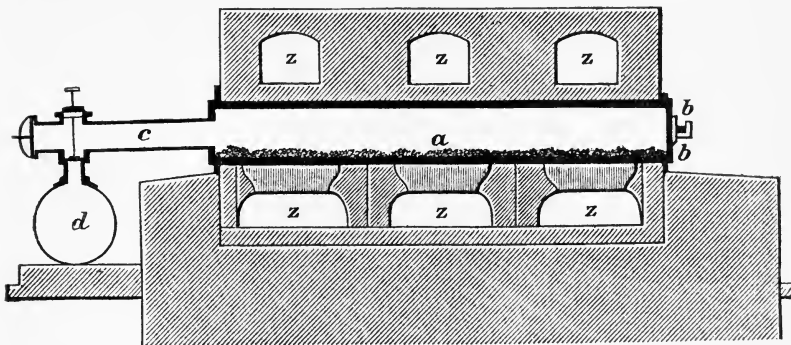

FIG. 2.—Oval horizontal retort.

Vohl and Wagemann,⁴ who combined sixteen in pairs to form a battery of retorts. Other shapes, small and low, rectangular and round, were also occasionally employed.

¹ "Deutsche Industrie Zeitung," 1878, 322; Ger. Pat. 2232.

² See pp. 44 *et seq.*

³ "The Oil Shales of the Lothians," p. 169.

⁴ Dingler's "Polytechn. Journ.," 135, 138; 139, 216.

B. Hübner¹ and Unger² selected the oval form of horizontal retort, which was found the most suitable as best able to resist the adverse effects of unequal heating, so that this pattern gradually displaced the others, and held the field until the introduction of the vertical retort. A longitudinal and cross section of this pattern are shown in Figs. 2 and 3.



FIG. 3.—Cross section of Fig. 2.

Its dimensions were: length 8 to 10 ft., width $27\frac{1}{2}$ to $31\frac{1}{2}$ in., height, $14\frac{1}{2}$ in., and thickness of metal (cast-iron) 1 to $1\frac{1}{2}$ in. The one end *a* of the retort is closed by the cover *b* fastened with bar and wedge, whilst the other end is fitted with a connection leading to the pipe *c* for carrying off the tar vapours. The receiver is represented by *d*, and the flues by *z z*.

A large number of such retorts—usually 10 to 12—were united to form a battery, heated from the one fire. The retorts were charged by throwing or pushing in the raw material, so as to cover the bottom of the retorts with a uniform layer about 4 in. thick. Non-bituminous lignite was burned on a flat grate, the consumption of fuel being 80 to 100 per cent, by volume, of the material in the charge. The distillation was complete in about eight hours, and the residual coke was raked out of the retorts, these being then recharged. The process was therefore intermittent, not continuous.

This disadvantage was felt, even in the early days of the industry, and attempts were made to afford a remedy. Thus, Perutz³ constructed a horizontal retort designed for continuous working; but this and other horizontal retorts for achieving the same object failed in practice, because, on the one hand, distillation was incomplete, and on the other the high specific gravity of the tar lowered the quality.

The first vertical retorts constructed for the production of tar were of the shaft pattern.⁴ Owing, however, to the extensive decomposition obtained, the resulting tar was unsuitable for further treatment. Unger⁵ considerably improved the construction of this retort by providing it with an external heating apparatus, so that the tar vapours were no longer brought into contact with the fire gases. His retort worked continuously, fresh quantities of the charge descending from a charging hopper at the top in proportion as coke was drawn away from the bottom. The Perutz⁶ retort was allied to this pattern.

The arrangement of these vertical retorts, however, was not adapted to ensure satisfactory distillation of the charge; but a thoroughly suitable pattern, already praised in the first chapter, was constructed by Rolle in 1858, and, with a few minor alterations, is still exclusively

¹ Dingler's "Polytechn. Journ.," 146, 211.

² *Ibid.* 150, 130.

³ "Die Industrie der Mineralöle" ("The Mineral Oil Industry"), p. 124.

⁴ Oppler, "Handbuch der Fabrikation Mineralischer Oele" ("Handbook of the Manufacture of Mineral Oils"), pp. 87 *et seq.*; Wagemann, "Dingler's Polytechn. Jour.," 140, 461.

⁵ Wagemann, "Dingler's Polytechn. Journ.," 150, 130.

⁶ "Die Industrie der Mineralöle" ("The Mineral Oil Industry") pp. 144 *et seq.*

used in the province of Saxony, having displaced the horizontal retorts in virtue of its advantages. It works continuously, and is more easily attended to than the horizontal pattern, less labour being also

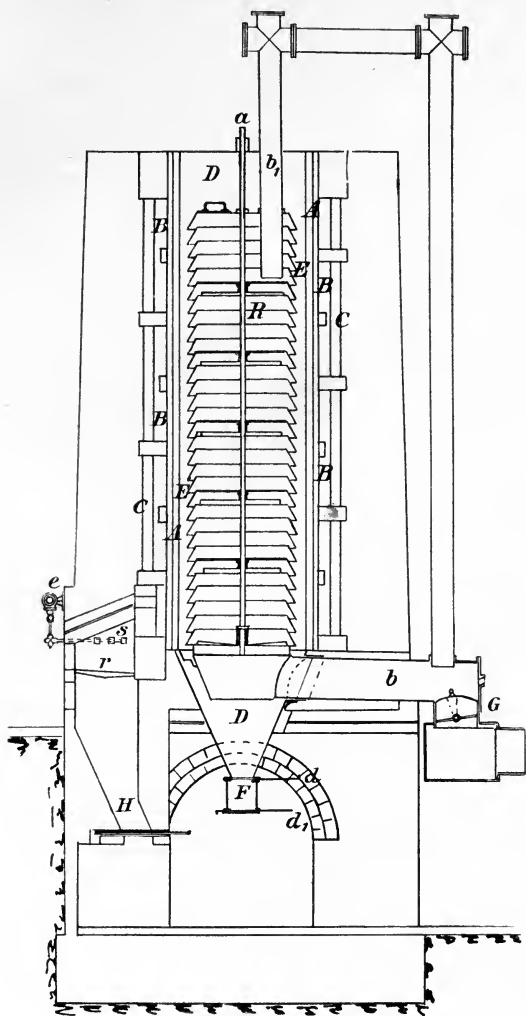

FIG. 4.—Rolle retort.

required. The output per unit time is five times as great as that of the horizontal pattern, and a higher yield of better quality tar is obtained. At first the (cast-iron) retorts were small, being only 3 ft. in diameter and $12\frac{1}{4}$ ft. high; but the dimensions were afterwards increased, the iron cylinder being surrounded by a thin jacket of firebrick, on ac-

count of the rapid wear and tear. Soon after, Rolle proceeded to build the whole cylinder of firebrick, and increase the dimensions all round, and at present the retorts measure 19 to 23 ft. in height (rarely 26 ft.) and 5 to 6 ft. in diameter. A Rolle retort is illustrated in Fig. 4. A is the firebrick cylinder, B the flues, also enclosed in a firebrick casting C. Inside the cylinder D is a series of superimposed bevelled iron rings, strung at regular intervals on an iron rod *a*. In section these rings resemble louvres.

The cylinder is built of tongued and grooved firebricks, as shown in Fig. 5, the bricks being $4\frac{1}{2}$ ins. high, 4 ins. thick, and 12 to 16 ins. long, with a longitudinal tongue $\frac{7}{8}$ by $\frac{7}{8}$ in. The bricks are rubbed together to make them fit closely in laying, and the small spaces in the joints are filled with a mortar which cements them firmly together. Various approved recipes are used for the mortar, consisting of

clay, finely ground sand, and ground firebrick or pottery clay, the mixture being stirred up with molasses and syrup. As a rule the joints of the firebrick cylinder run in superimposed horizontal circles; but Schliepack (Ger. Pat. 35,180), in building the retorts of the Waldau works, arranged the bricks in such a manner that the joints described a continuous spiral course from the beginning to the end of the cylinder.

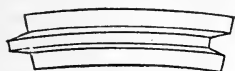

FIG. 5.—Bricks of Rolle retort.

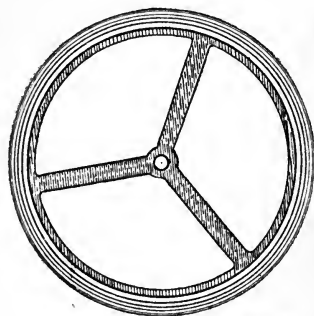

FIG. 6.—Cast-iron bell rings, Rolle retort.

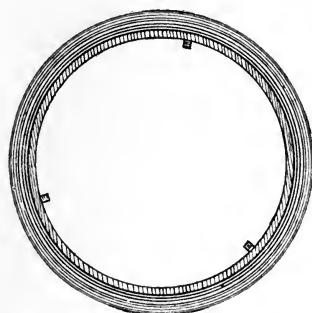

FIG. 7.—Cast-iron plain rings, Rolle retort.

At the base of the cylinder is laid a ring of slightly tapering bricks, rising gradually to the height of a grooved brick, from which point onward the ordinary bricks are used, the top of the cylinder being completed by a similar ring of tapering bricks of gradually diminishing size. This system, which has also been adopted in other places, offers the advantage of a closer bonding of the bricks than when each ring is complete in itself, the cylinder forming a complete whole and remaining impermeable to the gases for a long time. To increase this property, which depends largely on the use of good brick material,

the bricks are glazed on the inside; but this glaze soon cracks, and no longer keeps the cylinder gas-tight unless good materials have been used.

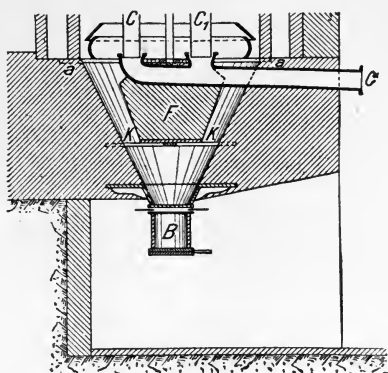

FIG. 8.—Iron cone of Rolle retort.

The cast-iron bell rings filling the interior of the cylinder are in part provided with cross stays which join the whole at the centre into a ring traversed by the iron bar. One of these rings is shown in Fig. 6,

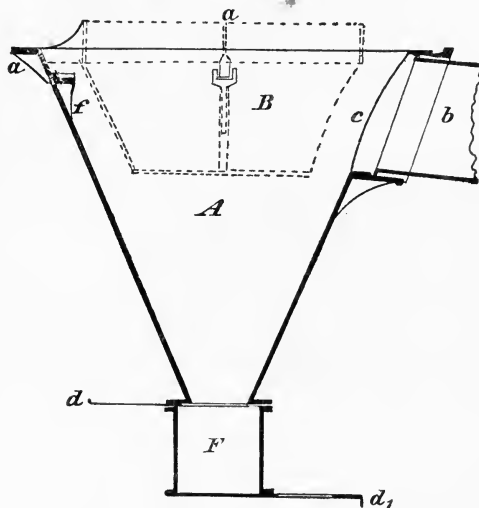

FIG. 9.—Cone and bell of Rolle retort.

whilst the plain rings are illustrated in Fig. 7. The whole series consists of about twenty-eight plain rings and six with stays; and the rings themselves are arranged that the upper ones rest on the rims of those below by means of lugs (*k* in Figs. 6 and 7). In this way, a small cylindrical chamber R is formed inside the firebrick cylinder, and com-

municates with the surrounding chamber E by means of the apertures formed between the rings. This chamber E is the distillation chamber, which receives the charge of material, and is 3 to 4 in. wide. The firebrick cylinder terminates below in an iron cone D, to which is attached a cylindrical iron box F having a capacity of $3\frac{1}{2}$ to 7 cub. ft. and fitted at the top with a slide which closes it against the cone, whilst a similar slide d' at the bottom enables the box to be emptied.

As shown in Figs. 8 and 9, the iron cone rests with its edge *a* on the brickwork and is bricked in. In some works the cone is built up of firebrick, as shown in Fig. 8, and carries an internal firebrick pillar



FIG. 10.—Iron cap for retort rings.

F supported by a cross K. This arrangement reduces the free space for the spent charge and causes the latter to slide down into the box B in a more uniform manner than in iron cones.

Inside the cone A (Fig. 9) a bell B is suspended at *f*, forming a support for the series of rings and the rod *a*, and carrying at *c* the pipe *b* which leads to the receiver. The series of rings is covered by an iron cap (Fig. 10), through which passes the discharge pipe *b'*, joining the second pipe issuing from the lower portion of the retort *b*. Below the mouth of the first pipe, and about one-third down the retort, is a bell ring covered by an iron plate, which thus divides the series of rings

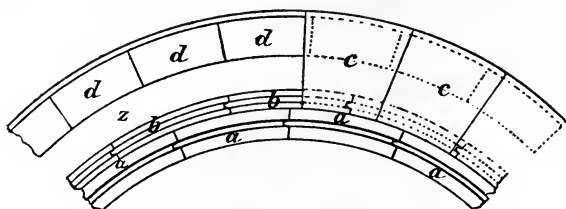

FIG. 11.—Section of bricked retort.

into two zones. In other plants the first delivery pipe for the distillation products is also led downward inside the retort itself, as shown in Fig. 8.

As a rule the lower portion of the firebrick cylinder is surrounded with a firebrick jacket in order to protect it from the heat, this protection being especially necessary since the general introduction of gas firing. For the purpose of forming the flues, the firebrick cylinder is surrounded, at a distance of about 8 in., with one of similar construction (rings of firebricks). The intervening space, which narrows by $1\frac{1}{2}$ to $2\frac{1}{2}$ in. towards the top, constitutes the flue for the fire gases, which are guided by baffles of taper firebrick. At the top of this flue the gases enter a passage which conducts them to the chimney stack.

Fig. 11 represents a portion of the section of a bricked retort, in

which *a* indicates the joint feathers, *b* the bricks of the jacket, *c* the flue cover plates, and *d* the bricks of the outer wall of the retort. The intermediate space *z* forms the flue. The retort is enclosed in an outer shell of baked brick. Heat is generated on the grate *r* (Fig. 4) with coal, which, however, must only be regarded as an auxiliary fuel, the principal heat being furnished by the gases produced in the distillation process, as will be described more fully later.

The firebrick used in building these retorts must satisfy two requirements, namely that it is inert towards the encrusted flue ash from the lignite fuel, and is able to withstand high temperatures without fusing.

The flue ash of the non-bituminous lignite fuel¹ is basic, and the material for the firebrick must be basic too. If acid material were used, the basic silicate of the ash would combine with the acid silicate of the firebrick to form a double silicate, and would become encrusted on the hot bricks. In cleaning out the flues, this encrustation would break off, tearing with it a portion of the brickwork and seriously damaging the retort. The most suitable bricks are those composed of pure aluminium silicate, these being able to offer the greatest resistance to heat on account of their high melting-point.

Mention is deserved by F. A. Schulz's patent (Ger. Pat. 6832) for replacing the iron bell rings by those of clay, viz. two-thirds ground firebrick and one-third stoneware body. These were said to be cheaper and easier to clean, but they did not answer in practice, and therefore the patent has not found technical application.²

Rotary retorts were formerly tried without success; and recently, Gräfe³ described a similar type invented by Gebr. Barnewitz, of Dresden (Ger. Pat. 156,952), with which he recommends that experiments should be tried in the lignite tar industry. So far, however, as the author is aware, this has not yet been done.

The Work of the Retort.

The retort is charged from the top, and when working properly, the lignite lies in the distillation chamber between the firebrick cylinder and the central rings, a further quantity being piled up to a height of 20 in. above the cover ring, so as to close the top of the retort. The hot gases from the grate traverse the flues and heat the retort. In the upper section of the retort the operation is chiefly one of dehydration of the damp charge, the liberated steam passing into the interior of the series of rings, and escaping through the delivery pipe, *b'* (Fig. 4). At certain intervals the spent charge is drawn off from the cone *A* (Fig. 9) into the box *F*, by opening the slide *d*; and in the same proportion a fresh quantity of charging material descends into the distillation

¹Schliepacke, "Über die Befuerung der Schwelzylinder" ("Firing the Retort"). "Jahresber. des Technilervereins," 1890-1.

²W. Scheithauer, "Die Fabrikation der Mineralöle" ("The Manufacture of Mineral Oils"), pp. 41 *et seq.*

³"Braunkohle," 8, 515.

chamber. The dehydrated charge sinks through progressively hotter zones in the retort, until it reaches the cone in a spent condition. Fresh portions of material must be piled on to the cover ring, to keep the top of the retort always closed.

In the same way as the steam and probably also a portion of the tar vapours are led away through the upper delivery pipe, the distillation products liberated in the lower portion of the retort pass off through the pipe *b*. These two pipes unite and discharge at *G* into the receiver, to which is attached an exhaust fan, or Koerting injector, to force the vapours on towards the condenser. If necessary, communication between the retort and the receiver can be cut off by means of a throttle valve.

The Condensing Plant.

The condensing plant is charged with the task of condensing the distillation products, so far as the same consist of vapours, and not permanent gases. In the Saxon industry the condensing plant is composed of a number of horizontal and vertical wrought-iron tubes of thin metal, the tubes being riveted, or else welded by the oxyhydrogen flame. Experience shows that a retort 5 to 6 ft. in diameter requires a condensing surface of 860 to 1070 sq. ft. The tubular system commences with wide tubes, communicating with narrower ones, these in turn leading to very narrow tubes. When the large tubes measure 36, 31, and 28 in. in diameter, the intermediate tubes will be 20, 16, and 12 in. and the final tubes only 1 in. in diameter.

The cooling effect is produced solely by the external air; and it is important that the vapours should pass through as long a track of tubing as possible. It has been found that if the vapours are artificially cooled (with water) in a short condenser to the same temperature as is attained in the atmospheric condenser, they still contain condensable constituents, whereas these are almost entirely absent when air is used. The most important point in the condensing process is the gradual cooling, which can only be attained with a long condenser, cooled by air. These conditions were thoroughly investigated at the time the practice of using the distillation gases for heating purposes was introduced (see Chapter XIV). Recently, Gräfe¹ has again convincingly demonstrated that air cooling is fully adequate for the condensation of the vapours, only about 0.7 per cent of condensable hydrocarbons being left at the conclusion of the process.

It will easily be understood that attempts were made at an early period in the history of the industry to substitute water cooling for air cooling, on account of the large space and heavy initial outlay required for the latter.² For the reasons given above, these endeavours proved unfavourable, and the old, proved system was retained. Of late years, water-cooled condenser plants have again been erected in order—ac-

¹ "Braunkohle," 1905, 388.

² O. Burg, "Polytechn. Centralhalle," 1858, 641; B. Hübner, "Dingler's Polytechn. Journ." 146, 215.

ording to Gräfe¹—to save space and capital outlay. The amount of cooling water required for these plants is at least ten times as great as that of the products of condensation.

The exhaust devices consist either of fans or Koerting injectors, the former being preferable owing to the defects of the latter, which consume far more steam than a fan, whilst the steam they introduce into the vapours retards condensation, the steam itself having also to be condensed.

The injector also accelerates the flow of the vapours, with unfavourable results, especially in the summer; and emulsions of tar- and water vapours, resulting in loss of tar, are formed—all of which drawbacks are obviated by the use of fans.

The heavy, less volatile vapours, paraffin and heavy hydrocarbons, are condensed in the first section of the condensing plant, where the tubes are mostly horizontal, whilst the oily constituents—low in paraffin—are deposited in the vertical tubes.

Formerly these two condensates—paraffin tar and oil tar—were occasionally separated, each being worked up by itself. This method, however, has failed to make any headway, it being far preferable, for technical reasons, to work up the tars together.

The tar from the condenser collects in a vessel where it is separated from the accompanying water which is run off, the tar being transported to the mineral oil works.

The Dry-distillation Process.

Up to the end of the 'eighties, the retorts were heated exclusively with non-bituminous lignite burned on flat grates, as shown in Fig. 4, in which *r* is the grate, the ash falling down into H and being discharged therefrom by opening the slide.

Attempts to supersede flat grates by step grates or semi-gas firing,² proved unsatisfactory, the principal object, namely a saving of solid fuel, not being achieved. As far back as the early 'sixties, Rolle began to experiment with the distillation gases for heating the retorts; but did not succeed in making this system work reliably on the large scale. He was unable to obviate the risk of explosion, and moreover obtained a lower yield of tar than with the older system. Another substantial hindrance to the success of his experiments was the lack of a fireproof material (brickwork) for this mode of heating. After firebrick became available for this purpose, Wernecke took up Rolle's experiments again, at Gerstewitz in 1887; and at the same time Ziegler carried on heating trials with distillation gases at Nachterstedt. Thanks to Wernecke's publications on this matter, other works successfully applied gas for this purpose; and now the system is in use at practically all the works in the province of Saxony.

¹ Gräfe, "Die Braunkohlenteer-Industrie" ("Lignite Tar Industry"), p. 27.

² Schliephacke. "Über die Befehuerung der Schmelzylinder" ("Firing the Retort"), "Jahresber. des Techniker-Vereins der sächs.-thür. Mineralölindustrie," 1890-1.

In general, the arrangements are such that the gas is drawn from the end tubes of the condenser by means of a Koerting injector and delivered to a cooler, where any tar vapours still retained are deposited. As already explained, when the condensing surface is sufficiently large, the gas contains only very small quantities of condensable matters, and on this account the gas cooler is omitted in some works. As shown in Fig. 4, the gas is then conducted through the pipe *e* to the retort, and is fed to the grate *r* through lateral chambers *s* provided with slits. In some works the gas is admitted to the second or third flue as well.

To counteract any explosions that may occur, and to prevent them from extending back to the condenser plant, an automatic closing device is provided in some works between the fire and the condensing plant. For this purpose Gräfe¹ recommends a sufficiently weighted explosion valve, as shown in Fig. 12. The valve *B* pivots at *a*, and is forced upward by the explosion, so as

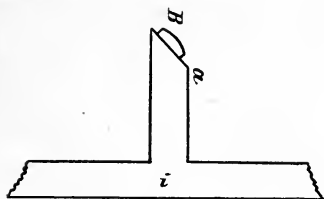

FIG. 12.—Explosion valve.
(*i* = Gas main.)

to allow the pressure to escape into the outer air. Experience proves, however, that a device of this kind is unnecessary, the Koerting injector which delivers the gases to the fire constituting a reliable stop and preventing an explosion from striking back to the condenser. Care must of course be taken to keep the injector always in good working order.

In general, the method of heating is not exclusively by gas, lignite being burned on a flat grate; and it is only in a few cases that gas firing is used by itself. As already mentioned, the firebrick now available is capable of withstanding the effects of gas firing for a considerable time.

The introduction of gas firing has brought great benefits to the industry in comparison with the old, flat-grate system. In the first place there is a very considerable saving in solid fuel, only 15 to 10 per cent (or even less)—referred to the volume of the charge—being now required against 35 to 40 per cent formerly. The cost of labour (stoking) has been reduced to about one-half, one man being able to look after 20 to 24 retorts. Most important of all, the output of the retorts has been increased by 20 to 30 per cent.

No hard and fast rules can be laid down with regard to the manner of heating the retorts. The temperature in the flues, from above downward, has been determined as 400 to 600° C.; and, when the retorts are working properly, the distilled vapours should have a temperature of 120 to 150° C. on issuing from the retort. The way in which the heating is conducted is mostly a question of experience, and depends on the character of the raw material, the underlying principle being to

¹ "Die Braunkohlenteerindustrie" ("Lignite Tar Industry"), p. 22.

obtain a favourable yield of tar and a usable coke that will find a ready sale.

The retorts are charged with the bituminous lignite as it comes from the mine: If the same be too large, it must be crushed, or large individual lumps must be broken by hand. Occasionally, small iron rollers are used for crushing. It is not advisable for the lumps to be larger than $1\frac{1}{2}$ to $2\frac{1}{2}$ in. in diameter.

If the material be too damp, it must be dried, which is effected on the charging platform of the retort house. The moisture content should not be less than 30 per cent or more than 60 per cent, since beyond these limits the material is difficult to work in the retorts—in the former event the bitumen is over-decomposed, being no longer protected by the liberated water vapour, whilst in the other case the charge bakes in the retort and will not descend freely. About 150 to 75 bus. of average material can be distilled in a retort of ordinary size in twenty-four hours, though sometimes the quantity is larger. With very high retorts and inferior material, up to 280 bus. can be distilled in a day. As a general rule, the better qualities of material

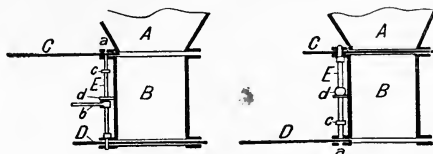

FIG. 13.—Coke box.

FIG. 14.—Coke box.

must be distilled more slowly than the inferior kinds, and therefore the quantity treated in unit time is smaller.

Before gas heating was introduced, the coke was drawn from the cone into the iron box about eighteen to twenty-four times in the twenty-four hours; but now this can be done thirty to forty times and even more, much depending, of course, on the adaptability of the material for distillation. In Figs. 13 and 14, A represents the cone and B the iron box. When the upper slide C is drawn, the coke slides down to B, where it is left to cool until the next "draw," whereupon it falls—on the lower slide D being opened—from B into the receptacle. In the early days of the industry numerous accidents were caused by opening the two slides at once, a large quantity of glowing coke falling out of the retort before one of the slides could be pushed in again, so that outbreaks of fire occurred and human life was endangered. To make the working of the slides independent of the operator, automatic slides have been constructed, e.g. by Grotowsky and Vogt; and the use of such slides has been prescribed by the trade guilds for some years past. The arrangement of the Vogt slide is shown in Figs. 13 and 14. The guides for the two slides, C and D, are provided with openings *a* in which works an iron bar E fitted with a handle *b*. Similar openings are provided in the draw-bars operating the slides. The rod E is provided with strengthening rings *c* near the two ends, and is of such

a length that it fills the one opening *a* completely, but only extends as far as the slide in the other opening. The handle *b* can be turned so as to rest on the support *d* provided on B, this being the case when both slides are closed and only the lower one can be opened (as shown in Fig. 14). In this position the upper slide cannot be opened, being prevented by E in *a*. If now the lower slide D be closed, the handle lifted away from *d*, and E be allowed to descend, then E locks the lower slide, and only the upper one can be opened. This position is shown in Fig. 13.

The coke falls from B either into trucks or pit tubs, and is still at a temperature of 360 to 400° C. Complete cooling, "quenching," is effected with water, for which operation various devices are used. Formerly the coke was quenched by simply dropping it into a brick tank filled with water. As flames are given off during this operation, the coke quencher must be placed at some distance from the distilling plant, and means must be provided to prevent the men from falling into the tank when the latter is full of hot coke, accidents having occurred from that cause, so that the quenching tank must be surrounded by railings or covered over with netting.

These drawbacks, together with the by no means inappreciable loss of coke, in the form of dust, are obviated by the newer quenching devices. The regulations issued by the Mining Police on 12 October, 1904, prescribe the adoption of measures to prevent outbursts of flame in coke quenching, and the scattering of glowing coke. The usual method at present is to quench the coke in the trucks or pit tubs into which it falls from the retorts—either by sluicing them with water, or immersing them or drawing them through tanks filled with that liquid.¹

In some works the coke quenching devices are suitably combined with those for loading the coke into railway trucks.

Attempts² made to cool the coke out of contact with air and without water, have proved unsuccessful. On the one hand the coke takes a long time to cool down, and on the other—a very important consideration—the resulting coke makes very inferior fuel.

The distillation process is continuous, work being carried on both Sundays and weekdays; and the only time the retorts are stopped is when they need repair. The retorts are cleaned out at regular intervals, which vary in different works, according to the material treated and the method of working—5, 9, or 12 months. Cleaning must be done whenever the retorts show signs of not working properly.

The bell rings and walls of the retort and cone get encrusted with half-burnt lignite, resinified tar, and impurities, such as sand or clay, in the charge; and the resulting irregularities of the surface prevent the charge from descending uniformly when the coke is drawn, leaving it

¹ According to Ger. Pat. 27,723 (A. Mann, Nuremberg) the coke is placed in perforated receptacles, which are then submerged in water. At the Dieskau works, water is passed through a perforated pipe traversing the coke truck. "Braunkohle," 2, 393.

² "Braunkohle," 4, 600.

jammed at the rough places. Cavities form in the charge and become filled with vapours, which may give rise to an explosion and interrupt the working of the retort.

The retorts are either cleaned out singly, or else several are stopped at the same time for this purpose. The retorts stopped for cleaning must be disconnected from the common receiver by tightly closing the throttle valve.

To cool down a retort the fire is drawn and the suction fan kept running, the coke being drawn and further quantities of charge added until the retort is cool. At this stage the bell rings are lifted out of the retort by means of lifting tackle, and thoroughly cleaned. The retort is also cleaned out; and when a whole group of retorts is stopped for cleaning, the delivery pipes and receivers, condensing plant and gas main are all thoroughly examined and cleaned. Any necessary repairs to the brickwork are also effected, and the grates are put in order. If the retorts are cleaned singly, they will be ready for work again in five to eight days; but in the case of a battery the stoppage lasts for three weeks.

No difficulty is encountered in replacing the rings and heating up the retort again. As a rule the half-spent charge, which was drawn on cooling down the retort, is fed in for the first charge on restarting. The distillation gas is led into the firebox as soon as it is sufficiently free from admixed air to burn at all. The coke cannot be regarded as marketable until the work has resumed its normal course.

The only important difficulties in working the retorts arise when the charge sticks and will not descend uniformly. One instance of this kind has just been discussed; and another may occur when the charge is too damp, the material then baking together and leaving cavities for the accumulation of vapour. The occurrence of such irregularities can be detected by watching the descent of the heaped charge at the top when the coke is drawn. It should slip down uniformly all round the distillation chamber, and if it does not, it must be assisted by means of long or short irons pushed down into the chamber to remove the obstruction. Care should be taken to see that the charge sinks down evenly all round, each time coke is drawn.

The yield of tar from the charge varies according to the percentage of bitumen in the latter. At the present time the average is about $2\frac{1}{2}$ to 5 lb. per bus. (50 to 60 lb.) of charge; but in former years, when there was an abundance of richer material available, it was considerably higher.

The Distillation Plant.

As a rule the retorts are grouped in batteries of ten to twelve, each battery having a common condensing plant and an exhaust apparatus. The retorts in a battery are arranged in a row and are lagged with a mixture of clay and molasses to prevent loss of heat by radiation.

Either one or two batteries are set up in line, with a safety wall

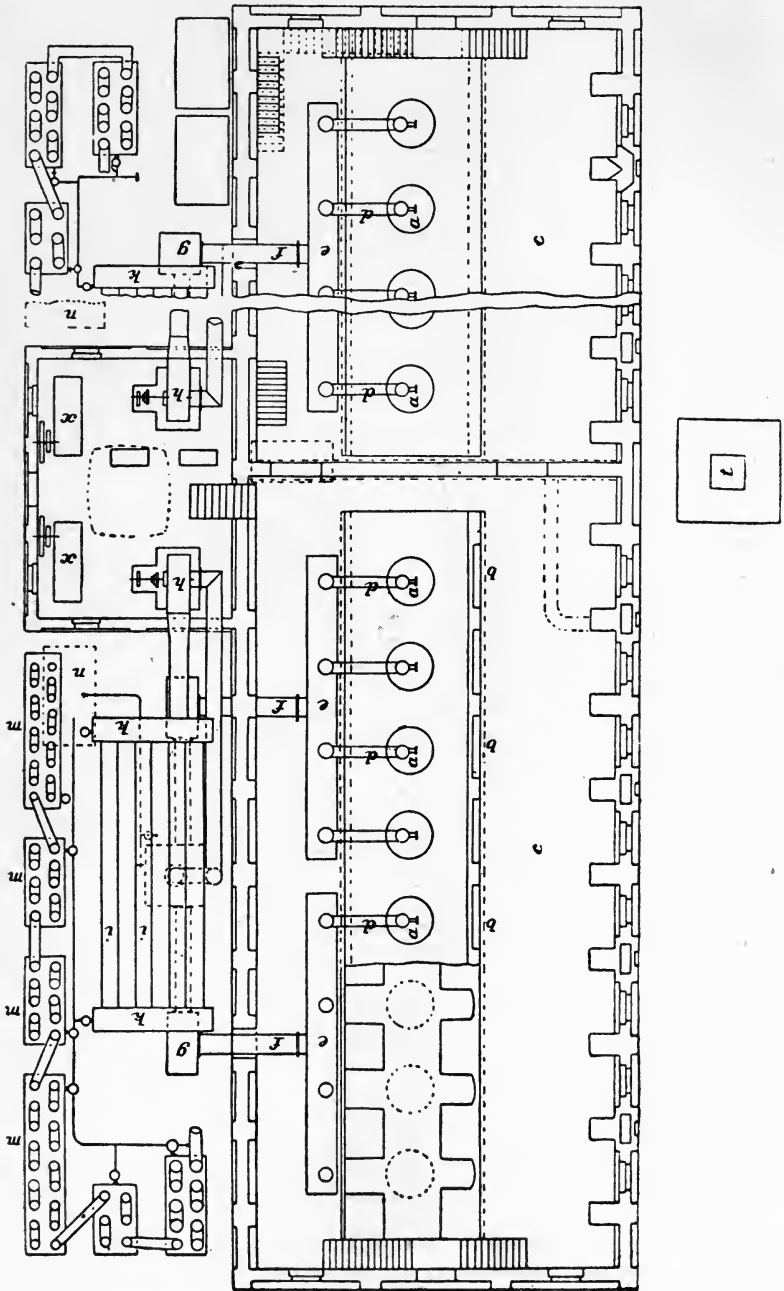

Fig. 15.—Dry-distillation plant. Plan and horizontal section.

dividing them, or else in two parallel rows—in both cases under cover. The two-row system was first introduced by Rolle, and subsequently adopted by Riebeck. The building is of strong construction and roofed with mill-board, though some retort houses are provided with corrugated iron roofs. The interior must be thoroughly well ventilated.

Fig. 15 gives a plan and horizontal section of a distillation plant with the retort batteries arranged in line; whilst Fig. 16 is a vertical section of the same plant. Here, *a* represents the retorts, *b* the fires,

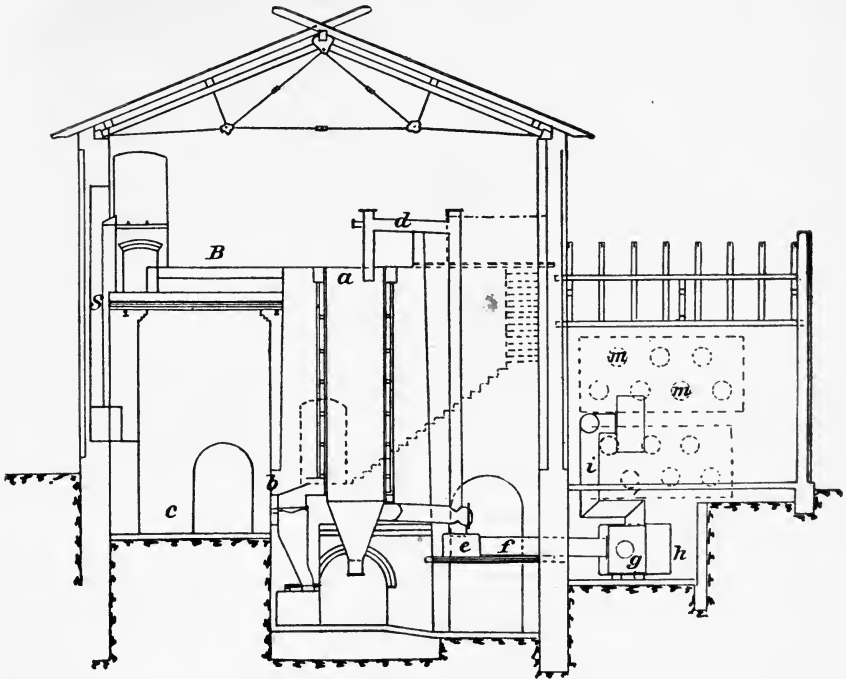

FIG. 16.—Dry-distillation plant. Vertical section.

c the stoker's platform (7 to 10 ft. wide), and *t* the chimney stack. The retort vapours draw off through the exhaust pipe *d* to the receiver *e* (which is common to each set of four retorts), and thence through *f* to the collector *g*. From this point they are delivered by the exhaust fan *h* to the horizontal condenser plant *i*, *i*, and then to the vertical condensers *m*, *m*. *x* is the steam engine driving the fan; but is now replaced in some works by an electromotor. The tar condensed in the horizontal tubes flows into the collector *k*, and thence to the tank *n* where the tar from the vertical condensers collects.

The gas escaping from the end tubes of this condenser is forced by means of a Koerting injector to the fire, or else is utilized as power gas.

B (Fig. 16) is the charging platform, to which the lignite is delivered by an aerial ropeway or, in this instance, in pit tubs. The fuel for the grates is sent down to the stoker's platform through the hopper S.

The plant, buildings, and fireproofing arrangements must be carried out in accordance with regulations issued by the Mining Police for the Halle district (1 April, 1906), the prescriptions of which are fully satisfied by the newer plants.

The capital expenditure on a retort and the corresponding condensing plant amounts to £500 to £600.

No definite particulars can be given as to the working life of the retorts. It is important that the best materials should be used in their construction, and that necessary current repairs should be effected. The retorts may last twelve to fifteen years or longer.

C. THE MESSEL TAR INDUSTRY.

The Retorts.

As already mentioned, Messel coal is high in both ash and moisture, and also differs from the lignite distilled in the Saxon-Thuringian industry by its lumpy character and lack of extractable bitumen. Hence, unlike Thuringian lignite, the decomposition of the bitumen has not to be attempted in working up this material. Dry distillation destroys the combination of the organic substances with the mineral matters, gaseous, aqueous, and easily refined oily distillation products being formed.

The utilization of Messel coal is carried on by the Gewerkschaft Messel at the Messel mine near Darmstadt, in extensive works which are without parallel, so far as the distillation plant is concerned, this being adapted to suit the peculiarities of the raw material.

The retorts used in Saxony will not work satisfactorily with open tops unless the charge contains enough pulverulent material to prevent the access of air from outside. One of these retorts was tried at Messel, but did not work unless the coal was finely crushed; the cost of this operation having therefore to be taken into consideration. Moreover, since the lumpy character of the coal enables dry distillation to be carried on in a current of steam, which, as is known, prevents decomposition from being pushed too far, the system of working was arranged on these lines from the outset. At one time the material was dried in a special stove (Ger. Pat. 48,413) in which the moisture content was reduced from 44 per cent to about 6 per cent, the dried material being then distilled in a current of steam in vertical retorts, which, by means of an easily operated Morton valve, could be emptied

into generators underneath, where the still lumpy residue (coke) was gasified, the resulting gas serving to heat the retorts. Hence there was no marketable coke as in the Saxon-Thuringian industry, all that remained being ash. To carry out this older process, a portion of the coal had to be burned, in order to dry that for the charge; whilst a further portion was consumed in raising large quantities of steam for the distillation process. The moisture in the coal was dissipated from the drying stoves into the air, whilst steam was being generated in the adjoining boilers. Even at an early date it seemed advisable to try and balance these opposing factors and to replace the boiler steam by the moisture from the stoves, for the distillation process. Moreover, the nitrogen content in the residual coke afforded the possibility of recovering ammonia therefrom by the Hubert Grouven process (Ger. Pats. 2709 (1878); 13,718 (1880); 17,002 (1880); 18,051 (1881)). Though this process had not proved successful in the peat industry with which its inventor was connected, it became the foundation of the Mond-gas process¹ and also the saviour of the Scottish shale oil industry. Unhappily, too little recognition has hitherto been accorded to Grouven's priority in this connexion, and his premature death prevented him from asserting his claims in person.

The Grouven process is based on the fact that by gasifying nitrogenous coke in presence of a large excess of steam, water gas is formed, and the nitrogen appears among the products of gasification as ammonia which is recoverable in the form of ammonia salts. However, since Messel coal must in any case be freed from a large quantity of moisture before it could be subjected to dry distillation, it furnished a large supply of steam without expense, provided this steam could be generated from the coal in the closed chamber required for the distillation process, and be afterwards utilized for the production of water gas. Furthermore, since the waste heat from the retorts is sufficient to convert large quantities of water into steam, it seemed feasible to generate the necessary steam from the damp coal by means of that heat. The water-gas process in turn furnishes enough waste heat for the dry-distillation process. The problem of combining these purposes was tackled by the Gewerkschaft Messel in many costly experiments, extending over a number of years and finally resulting in the elaboration of a new process which has now superseded the older one at the Messel works.

The process forms the subject of German Patent 200,602, of 23 May, 1906. The principle employed is illustrated by Figs. 17 and 18 (the latter showing the lateral elevation of the blower G, G), which are taken from the Patent Specification. R represents the retorts, the lower portion of which is made of firebrick; and, *a*, *b*, *c*, show the three stages of charging, whilst *d* is the common outlet for the water gas and the distillation vapours. F and G serve to maintain the circulation of steam through the stage *c* of charging

¹ See Fischer, "Kraftgas" ("Power Gas"), p. 142.

(Fig. 18). A, B, and C are the heating chambers, connected together

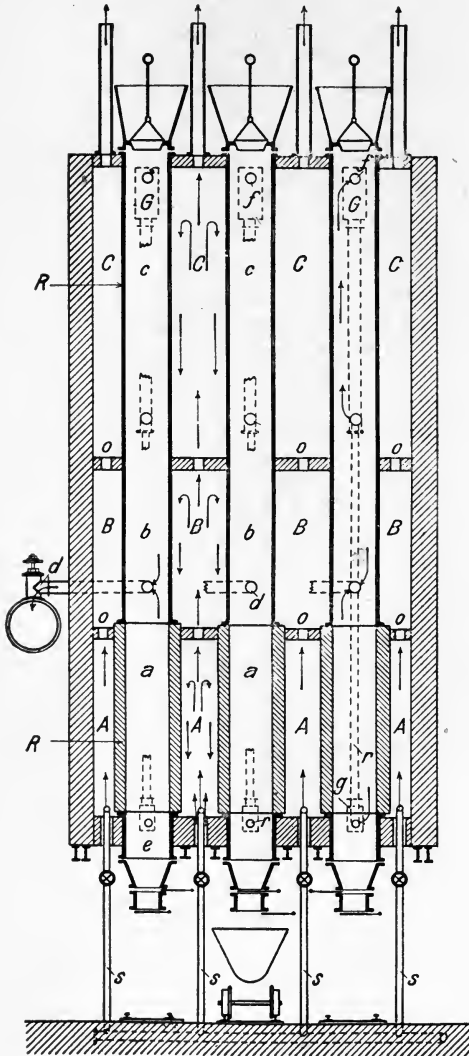

FIG. 17.—Messel retort.

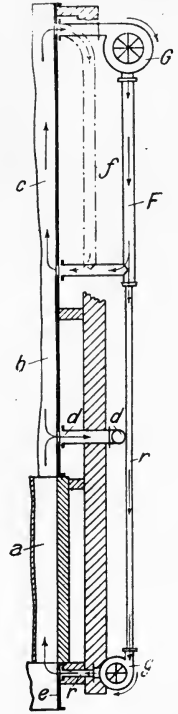

FIG. 18.—Blower.

by *o, o, o*, and each corresponding to one stage; whilst *s* represents the supply pipes for the heating gas.

The Work of the Retort.

The working process is divided into three stages; namely, the drying of the coal, in connection with the generation of steam; the distillation of the dried material; and the gasification of the residual coke with the steam generated in the first stage. The three stages are effected in the same retort, and in succession from above downward. The charging and discharging proceed continuously. No special mechanical devices are used to separate the various stages, this being satisfactorily accomplished in the manner in which the steam circulation is maintained. In correspondence with the three stages inside the retort, the external heating of same is effected in three zones, namely a zone of maximum temperature for the production of water gas, in the lowermost portion of the retort, *a, a*; a middle zone, *b, b*, in which the distillation temperature prevails; and the upper zone, *c, c*, which is devoted to the generation of steam, i.e. the drying of the charge. The heating chambers A, B, and C, are comparatively spacious; but, nevertheless, the only communication between them is by means of openings, *o, o*, of such small diameter as to preclude any convection of the heating gases from one chamber, or zone, to another; whilst only so much ascends from one space to another as is requisite for the amount of fumes generated at the actual draught. Owing to the roominess of the chambers, the convection therein is ample, and in each zone there is attained a uniform temperature which differs considerably from that of the preceding zone. Large quantities of heat are naturally required to expel the high percentage of moisture in the coal, and consequently the fumes must enter the steam-generating chamber at a very intense heat. As a matter of fact the temperature is so high that the operation would not stop at the expulsion of moisture, but would also affect the distillation of the dried material, were it not that care is taken to keep the temperature down to below that required for distillation, in the upper charging stage, by maintaining a very brisk circulation of steam in this stage. This steam, at a temperature of slightly above 100° C., enters at the hottest part and, itself becoming superheated, carries the excess of heat away to the place where the newly introduced coal, with all its original percentage of moisture, is situated. The circulation is produced by means of a powerful fan mounted on the retort, and is so efficacious that the steam remains free from any dry-distillation products and can be led away for the production of water gas without causing any decomposition of valuable constituents. On the other hand the utilization of the heat is so complete that the fumes escape into the chimney at a temperature of only 200° C.

The steam, which has greatly increased in quantity through the moisture absorbed during the circulation, is forced by a small blower into the bottom end of the retorts and ascends therein, forming water gas as it rises. The retorts are heated by the very large quantity of mixed water gas and distillation gas formed, amounting to over 500

cub. ft. per cwt. of coal in the charge, after all the condensable and extractable constituents in the gas have been removed. Even after the requirements of the retorts have been satisfied, there remains a considerable excess of gas, which is led away to the power station and utilized for steam raising there. The calorific value of the gas is very high, and, after elimination of the circa 20 per cent of carbon dioxide present, it is admirably adapted for incandescent lighting. The distillation vapours and water gas are drawn off through a common exhaust pipe about one-third of the way up the retort. The mixture is first freed from particles of water vapour, and then passed in succession through the ammonia-recovery plant, the condenser plant and oil washery, to a gasholder, for delivery to the several centres of consumption. The portion destined for the gas engines is passed through purifiers charged with the usual ferric-hydroxide purifying mass, for the purpose of eliminating the contained sulphuretted hydrogen.

The plant for treating the vapours before they reach the gasholder will be more fully described later. The following points in connection with the raw material may be mentioned here: the coal coming from the pit is crushed in a breaker and separated from dust and slack on special screens, since these finer portions would present an excessive resistance to the passage of steam in the retorts. The dust and slack are utilized in other ways by the aid of special appliances. Screens of perforated sheet iron were formerly used, but were afterwards discarded because they are liable to become obstructed in consequence of the clayey nature of the material, especially in wet weather. At present all the screens used are provided with rotary knives projecting through the slits and keeping the latter clear of obstructions. The coal, reduced to lumps between a hen's egg and a goose egg in size, and classified, is transported by means of ordinary conveyors to the charging hopper of each retort. The retorts are emptied by means of a suitable discharging device which is set in operation for a short time every half hour. The discharged residue can be a perfectly pure ash, which is grey in colour—in contrast with the red ash furnished when the coal is burned in a grate—but turns red on calcination. In practice, however, this complete incineration is unnecessary, more gas being already produced than is required; and therefore, in the absence of any means of utilizing the surplus gas for the present, the residue is withdrawn with a carbon content of about 8 per cent and removed to the spoil heap.

Twenty-four retorts of small sectional dimensions constitute a battery, capable of treating 26 tons in twenty-four hours. Charging and discharging proceed continuously.

The Treatment of the Distillation Vapours.

(a) *Recovery of Ammonia.*—The gaseous mixture from the retort, after being freed from water vapour, is scrubbed with dilute sulphuric acid in towers of the Glover type, to remove the ammonia from the

still hot gases. The resulting ammoniacal solution is evaporated by the heat contained in the vapours, i.e. the liquid is used to cool down the hot gases. The sulphate of ammonia obtained on evaporating the solution is centrifugalized, dried, and sold.

(b) *Condensation*.—The partially cooled mixture of gas and vapour is further subjected to the cooling action of water, the latter being evaporated in the process. This water is the water of condensation, which was previously cooled in cooling towers and is cooled again after being rewarmed. The resulting water of condensation serves as cooling water and is maintained in circulation through the tubular condensers and the cooling towers, which are of similar construction to the recooling plants of condensing engines. In this way the effluent water is reduced to a minimum, and the surplus is got rid of by using it to quench the hot residues on the spoil heap. Finally, the vapours are cooled with water from the pit mains, and are passed onward to the

(c) *Oil Washery*.—This is similar to the corresponding apparatus for the recovery of benzol in coking plants, and therefore needs no further description here. The highly volatile oil ("naphtha" or "photogen") thus recovered is pale in colour and forms about 8 per cent of the total crude oil produced. If it be left in the gas it increases the heating value of the latter; but since the gas has no marketable value and is already present in excess, considerable importance is attached to the oil washery.

(d) *The Exhaust Fans*.—These are of the high-pressure type and are coupled direct to electromotors. Particular importance is attached throughout the whole plant to minimizing the resistance offered to the passage of the mixture of gas and vapour, since power is thus saved and the use of expensive valveless gas pumps can be dispensed with.

D. THE RECOVERY OF SHALE TAR IN SCOTLAND.

The Retorts.

Horizontal retorts were originally used in the Scottish industry also, until eventually, as in the Saxon-Thuringian industry, the vertical pattern came into general favour.¹

These horizontal retorts were of oval, rectangular, or  section, made of cast iron, and closed at one end by an iron door, whilst the other end was provided with a delivery pipe for conveying the liberated vapours to the condenser plant. As the retorts were charged and emptied through the door, the operation was, naturally, intermittent.

In order to remedy this drawback, the vertical retort was soon adopted, a number of which were already in use at the end of the 'sixties. The older retorts of this type were narrow, oval, or circular cast-iron pipes, surrounded with brickwork. Charging was effected through a hopper at the top, whilst the spent shale was let out at the bottom and fell into a trough filled with water which, at the same time,

¹ "Journ. Soc. Chem. Ind.," 1897, pp. 876 *et seq.*

acted as a seal. One of these retorts is shown in Fig. 19, *a* being the iron pipe forming the distillation chamber, *b* the charging hopper, and *c* the outlet into the water trough. The distillation vapours escaped through *e* to the condenser.

In addition to the advantage of continuous working, the vertical retorts gave a yield of tar 25 to 30 per cent higher than the horizontal pattern. Coal fires were used for heating the retorts, but the grates were so large that the iron suffered extensive corrosion and the retorts became useless in six to nine months.

Young conducted exhaustive experiments with a view to modifying the distillation process and to obtain a tar richer in paraffin, the far-reaching decomposition in the old process being effected at the expense of the paraffin content. At the end of the 'sixties he built retorts of in-

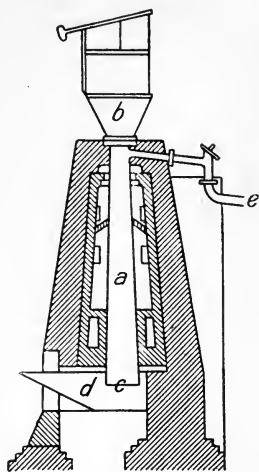

FIG. 19.—Old Scottish retort.

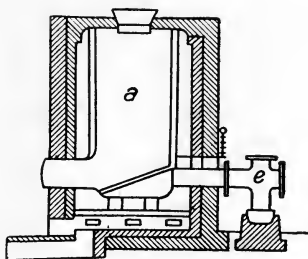

FIG. 20.—Young's first retort.

creased diameter and lowered the distillation temperature to low red heat. This type of retort is illustrated in Fig. 20. In contrast to the old retorts, the vapours are led off, not at the top, but underneath at *e*, and the retort (*a*) is jacketed. Early in the next decade Young began to use the spent shale, instead of coal, for heating, this material containing sufficient carbon to furnish the requisite amount of heat. Another type of retort constructed by him was distinguished by the ingenious device through which the spent shale fell into the grate. The device, however, was too delicate to be suitable for being operated by workmen with hundreds of retorts to look after. By means of this device, however, Young was able to prove that the necessary distillation temperature could be attained from spent shale.

A retort which worked better in practice was that constructed in 1873 by N. M. Henderson and shown in Fig. 21. The retorts A, A are charged from the truck C, and the spent shale falls down through the

rotary closing device *a* to the fire-box B, which is closed by *b* when the retort is in work. The vapours escape through the pipes *f, f* (which can be shut off from the retorts by *g*) to the condensing plant, whence the permanent gases are led through *c* into the fire. The ashes fall through *d* into D, and the fire gases pass away through *e, e*.

The first set of these retorts was installed at the Oakbank Works in 1874, and remained in use until 1886, when the retorts were replaced by an improved pattern after working well for twelve years. Plant containing Henderson's retorts was also set up at Broxburn in

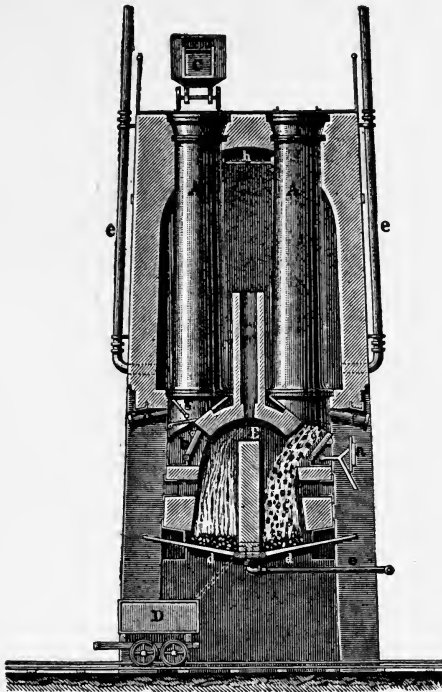

FIG. 21.—Henderson retort (1873).

1878, and proved so successful in dealing with the shale there as to contribute largely to the prosperity of the Broxburn Oil Co. at that period.

Utilizing the success of Young and Henderson, the shale distillers who were still using the old vertical retorts reconstructed the heating arrangements in order to burn the spent shale, thus reducing the distillation temperature considerably. The tar obtained was of far better quality and richer in paraffin than hitherto, whilst at the same time the working costs were reduced.

No success attended the attempts made at Oakbank to increase the

sectional dimensions of the retorts and heat a number from a common furnace; and the Henderson pattern remained the best until 1881. It was exclusively used at Broxburn, Burntisland, and Linlithgow, whereas at Addiewell, Uphall, Dalmeny, and Oakbank the old and reconstructed retorts continued to be employed.

Up till that time the yield of tar was regarded as the most important feature of the distillation process, ammonia recovery being merely a side issue; but Beilby and Young began to investigate the possibility of increasing the output of ammonia from the shale. With this object they elaborated a new process and constructed suitable retorts for carrying it out, the idea being to subject the shale to an increased temperature in the retort itself, after the bulk of the bitumen had been removed, and thus recover the ammonia. The chief objection to this new

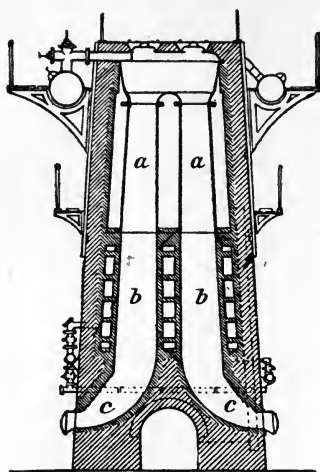

FIG. 22.—Pentland retort.

process was the possibility of an adverse influence on the quality of the tar, the decomposing effect of high temperatures on that important product being already known. This anxiety, however, proved unfounded, an excellent tar being obtained. The new retorts consisted of an upper portion of cast iron, where the shale was distilled at a low temperature, and from whence it then descended into the lower fire-brick portion of the retort. Here the temperature was far higher than in the upper portion, and steam was admitted, a high yield of ammonia being obtained (by the process already sketched on p. 21), together with a larger amount of gas.

The distilling process was more difficult to supervise with this type of retort, there being two different temperatures to watch and regulate. The first retorts were set up at Oakbank in 1881 and worked well, the output of ammonia being doubled and the tar containing more paraffin than that from other retorts. The only drawback was the close super-

vision required, and the grave results that followed any negligence in this respect. For example, if the lower portion of the retorts grew so hot as to fuse the shale, they got choked up. These drawbacks induced Young to make remedial alterations and he constructed retorts of the type illustrated in Fig. 22, and known as the Pentland or Young and Beilby retort, of considerably larger dimensions and with a bent pipe *c* for discharging the spent shale, this form giving increased accessibility. To facilitate supervision, the fire grate was replaced by a gas producer. Like the earlier Beilby pattern, the upper portion *a* of the new retort was of cast iron, the lower *b* being of firebrick. The yield of tar and ammonia was thoroughly satisfactory. Attempts were

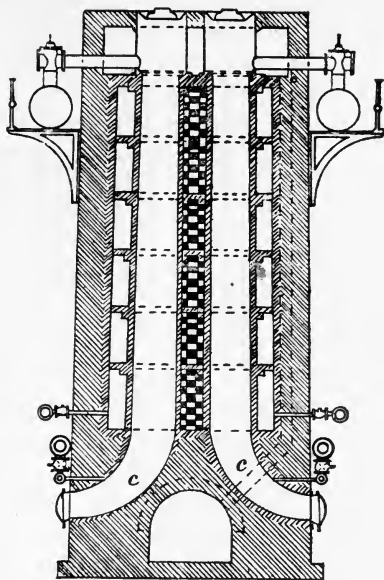

FIG. 23.—Firebrick Pentland retort.

next made to improve this type of retort still further, both in point of arrangement and working, the cast iron in the upper part being superseded by firebrick on account of the difficulty experienced in getting a proper gas-tight joint between the two materials. These wholly firebrick retorts, however, only worked for a short time, since, in the words of Beilby: "the joints between the bricks began to leak and the walls of the retorts cracked". It thus appears that a construction which was found to answer well in Saxon Thuringia was unsatisfactory in Scotland, owing to the nature of the raw material and above all to the essentially modified distillation process. In 1885 the Hermand Oil Co. set up distilling plant containing Pentland retorts of increased height, each retort being provided with a separate charging hopper instead of being charged in pairs. The extra height of the retorts proved bene-

ficial; but the renewed attempt to construct the retorts solely of firebrick (Fig. 23) failed once more, and the idea of modifying the well-tried system already in use was abandoned. The interruption experienced in the old Pentland retorts through the discharge passage becoming blocked with fused shale, was occasionally encountered in this case too; but, owing to the improvements made in this direction in the newer systems of retort, it has now disappeared.

One of these patterns was designed by Henderson, and is illustrated

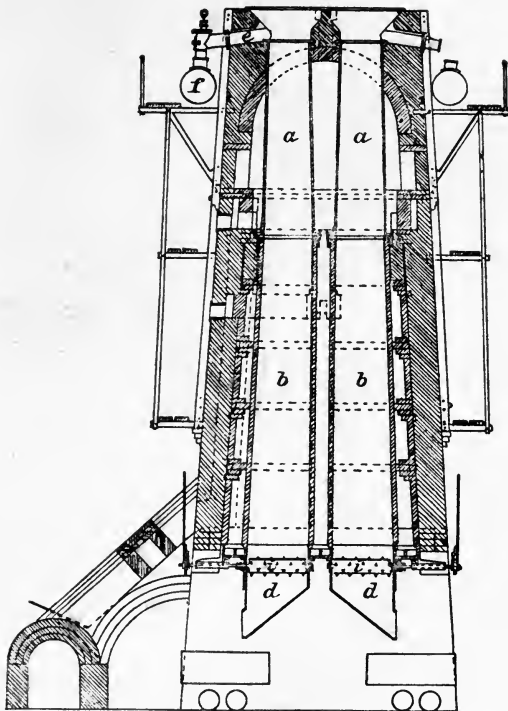

FIG. 24.—Henderson (improved Pentland) retort.

in Fig. 24.¹ The shape is copied from the Pentland retort, the diameter being elongated, the upper portion *a* constructed of iron, and the lower *b* of firebrick. The joint between the two is very carefully made, so that any leakage there seems impossible. The retort is $27\frac{1}{2}$ ft. high, and the temperature in the upper zone is maintained at 400° C., whilst that in the lower zone is 700° C. To prevent the shale from caking together and obstructing the retort, the shale itself is kept in continuous motion by a toothed roller *i* at the bottom of the retort which is made to revolve slowly. By this means the spent shale is discharged

¹ "Journ. Soc. Chem. Ind.," 1897, 983.

from the retort and falls down into the iron box *d*, whence it is run down into trucks. The distillation vapours escape through the exhaust *e* to the receiver *f*. This system presents important advantages. Since the spent shale is discharged continuously, instead of intermittently, the retorts are easy to work and require little attention. From the charging hopper, which holds enough shale for eighteen hours' working, fresh quantities of charge slip down into the retort in proportion as spent shale is discharged below. As the author has himself seen, this pattern of furnace is the only one used at Broxburn. There a battery of eighty-eight retorts distils 160 tons of shale in the twenty-

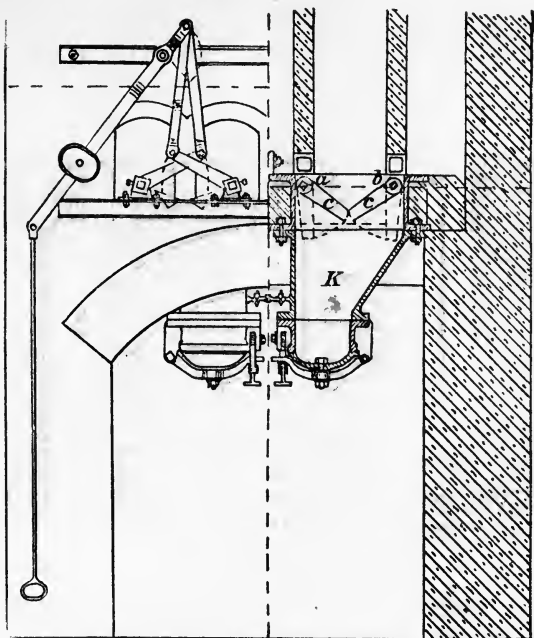

FIG. 25.—Device for discharging spent shale.

four hours; and only four men are required to look after the whole during the day shift, whilst two are sufficient in the night shift, the retorts being then charged from the hoppers exclusively. The yield of ammonia is still better than that from the other retorts, and the recovered tar is of good quality.

Another type of retort, built for and achieving the same purpose, is that of Crichton of Philipstown. In general it is similar to the Broxburn retorts, except for slight modifications in detail and firing. To discharge the spent shale by mechanical means, a device, illustrated in Figs. 25 and 26, is provided at the bottom of the retort, consisting of two shafts, *a* and *b*, and a set of arms, *c, c*, to each. These arms

slope downward (Fig. 25) at a relative angle of 45° , fitting closely together and thus closing the bottom of the retort. The spent shale is not discharged continuously, but intermittently by imparting a rotary motion to the shafts, thus causing the arms to open and allowing the shale to fall into the underlying iron box K. This is done every six hours. As with the Broxburn retorts, the heating is effected by the distillation gas assisted, in case of need, by gas from a separate producer.

The retorts constructed by Bryson and set up at the Pumpherstons works are very closely allied to the two just mentioned (see Fig. 27). The retort is of circular cross section, and is of larger dimensions than any other in the Scottish industry, being $26\frac{1}{2}$ ft. high and 3 ft. in diameter. The distillation chamber will hold 160 cub. ft. of shale, in comparison with 106 cub. ft. in the Broxburn retorts, and 25 cub. ft. in the old vertical retorts.

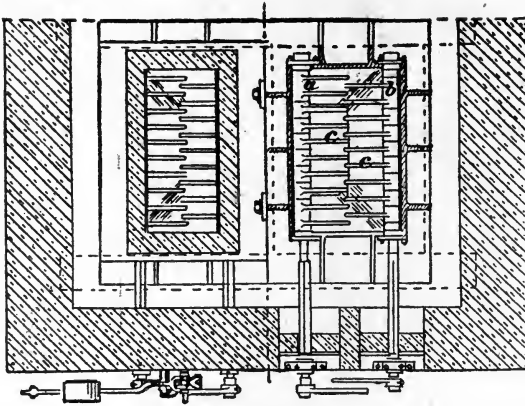

FIG. 26.—Device for discharging spent shale (plan).

The upper portion *a* is of cast iron, and the lower *b* of firebrick. The charging hopper will hold enough shale to last for twenty-four hours. The spent shale falls down into an iron box *d* which surrounds both retorts. As shown in Fig. 28, which is a section through the two retorts along the line A to B, the spent shale is discharged mechanically. At the bottom of each retort is an iron table *t*, the plate *e* of which closes the retort and supports the spent shale. Through the middle of the table passes a steel shaft to which is secured an upwardly bent arm *i* corresponding to the circumference of the plate. On the shaft being rotated, this arm sweeps the plate and ejects the spent shale thereon into the box *d* whence it is removed from time to time. During the distillation process the shaft rotates slowly, and the iron arm discharges the shale continuously, whilst fresh material falls down out of the charging hopper. Five tons of shale are treated per diem. The Pumpherstons retorts are heated with

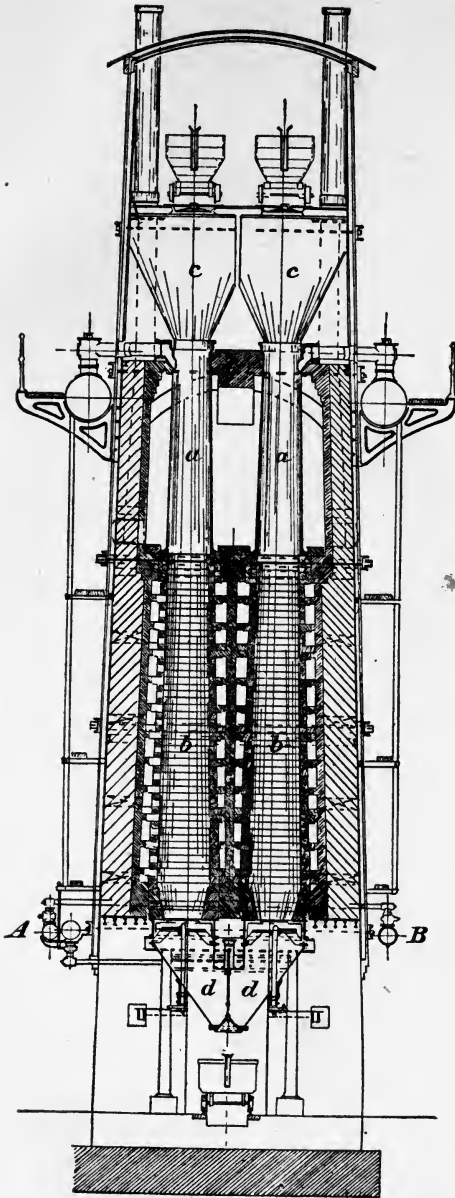

FIG. 27.—Bryson retort. Elevation.

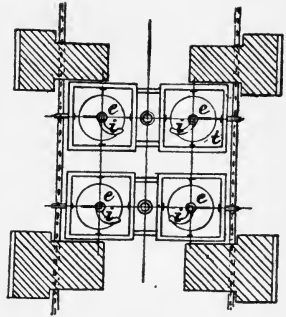

FIG. 28.—Bryson retort. (Section A-B.)

distillation gas exclusively, as at Broxburn. The number of retorts at work is 208 and satisfactory results are obtained.

This type of retort is perhaps the most perfect that has been used in the Scottish industry, having the highest capacity and smallest working costs.

In concluding this section it is desirable to compare the development of the retorts in the two large distillation-tar industries. Whereas in the German industry, apart from the utilization of the gases, there has been no appreciable alteration in the arrangement of the retorts since the days of Rolle, it is only about fifteen years ago that the Scottish industry improved its retorts to their present state of perfection. The reason for this was in the difficult nature of the Scottish raw material and the different method of carrying out the distillation process.

The Work of the Retort.

The method of working the retorts has been described in treating of the various patterns. Common to all is the method of charging through a hopper at the top, and discharging at the bottom, this latter operation being—as already described—performed intermittently, by mechanical devices, in the newer types.

The distillation vapours are now generally led away at the head of the retort instead of at the bottom as in the old Henderson pattern.

The Condensing Plant.

The vapours are drawn out of the retorts and into the condensing plant by exhaust fans. The condenser consists of a system of cast-iron tubes the diameter of which, in large plants, commences with 2 ft. and decreases to 18 in. In other works, smaller diameters (about 4 in.) are used, according to the number of retorts employed.

Air is used as the cooling medium. The last constituent to be condensed, the benzol, is separated beforehand from the tar proper in another apparatus. The condensation products are collected in tanks, where the tar separates from the water.

The Distillation Process.

Before the shale coming from the mine is distilled it is put through a breaker and reduced to lumps about $\frac{1}{2}$ to $\frac{3}{4}$ in. in diameter. Formerly this was done by hand, with long-handled hammers. The broken shale drops from the breaker into small trucks in which it is hauled along an inclined plane, by means of a wire rope or a chain, to the retorts.

The method of charging and emptying the retorts has already been described in dealing with the various types, being intimately connected with their structural arrangement.

At present the retorts are heated by the distillation gases, with producer gas as an auxiliary fuel, whilst in the older retorts the spent shale is still utilized for this purpose.

In the course of years the cost of the distillation process has been considerably reduced. At the present time the quantity of material treated in unit time is larger, and a higher yield of tar and ammonia is obtained. The estimate of the Broxburn Oil Co. for the cost of distillation, including the raw material, per 22 gal. of tar produced at different periods, is as follows:—

In 1897:	3s. 6d. (new type of retort).
„ 1879:	4s. 6d. (Henderson retort).
„ 1877:	6s. 3d. (vertical retort).
„ 1876:	8s. 0d. (horizontal retort).

With the newest retorts of the Pumpherston Co., 5 tons of shale are distilled in twenty-four hours, whilst $4\frac{1}{2}$ tons are treated at Broxburn, in each retort. The yield of tar varies with the raw material and the type of retort, 1 cwt. of shale furnishing about 8 to 10 lb. of tar.

In contrast to the Saxon-Thuringian industry, the distillation residue is worthless, and is tipped on to spoil heaps, which have attained to the dimensions of respectable hills in the vicinity of the larger works. Since the shale is still very hot when tipped, these heaps smoke and disengage malodorous gases.

The Distillation Plant.

In the Scottish industry the distillation plants are generally much more extensive than in Saxon Thuringia, and heavy capital expenditure has been incurred. The plants are mostly in the centre of the shale area and in the vicinity of the mines.

To round off the subject, a brief account may be given of the retorts used in other shale industries.

In the south of France, retorts similar to shaft furnaces (such as those formerly used at Reutlingen, Wurtemberg, for distilling the local Lias shale) were employed at first, being afterwards replaced by vertical retorts, constructed and equipped like stills. With this type of plant, however, it was found impossible to distil the shale at a profit.

After exhaustive investigations and reports, attempts are now being made to benefit by the progress made in the Scottish industry and to carry on the process on similar lines.

The Autun shale furnishes 7 to 8 per cent and that of Bruxières 5 to 7 per cent of tar (crude oil) with a specific gravity of about 0.900.¹

In Australia use is made of retorts similar to those employed in Scotland.

¹ "Génie Civil," 1908, 54, 136, *et seq.*

CHAPTER IV.

THE DISTILLATION PRODUCTS.

Four different products are obtained from the dry distillation of bituminous raw materials, namely: tar, consisting of liquid and solid hydrocarbons; tar water, containing ammonia and the organic compounds of same; gas, the gaseous products that do not condense at the ordinary temperature and pressure; and residue, i.e. the remains of the raw material after the bitumen has been expelled therefrom.

A. THE TAR.

Distillation tar forms the main product of the dry distillation, and the quantity and properties of this product decide whether a given bituminous raw material can be profitably treated. From this point of view—as stated on p. 1—peat tar and wood tar cannot be regarded as distillation tars in the strict sense of the term, since these, like coal tar, occur as by-products of the distillation of the corresponding raw materials, whereas distillation tars form intentional main products, and are always subjected to further treatment by distillation, their employment as tar being out of the question.

Distillation tars consist of liquid and solid hydrocarbons of the fatty series, associated with small quantities of aromatic, acid, and basic (nitrogenous) substances. Oxygen compounds (alcohols and esters), sulphur compounds, and aldehydes have also been detected in the tars. Further details on this point will be found in Chapter X.

Lignite Tar.

The tar is yellow-brown or dark brown in colour, and has the consistence of butter, at the ordinary temperature. In the melted condition it has a dark green lustre, and in some cases smells strongly of sulphuretted hydrogen. The specific gravity, which is usually determined at 44° C. (111° F.), varies between 0.850 and 0.910. In former days, when better raw material was available, the specific gravity of the tar was lower, rarely exceeding 0.880. The melting-point lies between 25° and 35° C. (or higher); the constituents boil at 80° to 400°, the bulk distilling over between 250° and 350°.

Messel tar (crude oil) is greenish-brown in colour, with the consistence of ointment, and a specific gravity of 0.855 to 0.860.

Shale Tar (Crude Oil).

The Scottish shale tar is brown-red in colour, with a dark green fluorescence. The specific gravity of the tar now produced is 0·860 to 0·900 and over. The melting-point varies between 20° and 30° C., and the boiling-point of the fractions is on a par with lignite tar. The nitrogen content is higher than that of the latter, and amounts to 1·16 to 1·45 per cent.¹

The shale tar produced in the south of France² is a black, fluorescent liquid smelling like garlic. The specific gravity is 0·870 to 0·910.

*Value of Distillation Tars.*³

The value of the tar depends, on the one hand, on the value of the manufactured products obtained therefrom, namely mineral oil and paraffin, and on the other on its content of acid and basic constituents. These substances have to be isolated from the tar and (chiefly) its distillates in order to form marketable goods; and for this purpose an outlay is incurred in labour and the cost of chemicals.

The higher the market value of the manufactured products from distillation tar, and the lower its content of acid and basic substances, the greater its value. Since, however, the market prices in question, and especially those of the paraffin, are liable to considerable fluctuation, no definite pecuniary value can be fixed for the tar.

Apart from these circumstances the conditional value of lignite tar has declined of late years, owing to the inferior quality of the raw material, which in turn finds expression in the properties of the tar. The specific gravity is higher than formerly, tars of specific gravity 0·820 to 0·850 being no longer obtainable. On the other hand the melting-point has declined, a circumstance pointing to a smaller content of paraffin.

A contrast is afforded by the Scottish shale tar, which has improved in quality of late years, owing, as already mentioned, to the superior product furnished by the new type of retorts. The percentage of paraffin especially has increased, as is indicated by the lower specific gravity and the higher melting-point.

The cost of production and working up the tar have decreased all round of late years, thanks to the improvement introduced into the arrangement of the retorts, and to the simplification of the working processes, whereby labour has been economized—the most essential feature of all modifications of such processes.

B. THE TAR WATER (AMMONIA LIQUOR).

Whereas in the Saxon industry, this product is of little value, it forms a highly important item in other distillation-tar industries; and

¹ Beilby, "Journ. Soc. Chem. Ind." 1891, 126.

² F. Miron, "Oesterr. Zeits. Berg- u. Hüttenwesen," 1897, 45, 80.

³ See also Chapter XI.

we have already seen that special stress has been laid on increasing its content of ammonia by modifying the distillation process.

Lignite Tar Water.

About 40 to 50 per cent of the charge of bituminous lignite is recovered in the form of tar water; and the proportion is still higher, for reasons already given, when a Koerting injector is used for drawing off the distillation vapours to the condensers.

The tar water has a faintly alkaline reaction. In the fresh state it is yellow in colour, but soon acquires a reddish tinge on standing, and finally turns red. The specific gravity is 1.02 (2° to 3° B.). The ammonia content varies between 0.03 and 0.07 per cent, and depends on the amount of nitrogen in the lignite.

Many attempts have been made to recover ammonia from the tar water; but the exhaustive researches of Grotowsky, Krey, and the pupils of the latter unanimously demonstrated that the percentage of ammonia is too small to make its recovery as sulphate profitable.

For some years this tar water has been used as a fertilizer, and the systematic experiments carried out by Scheele¹ on a large farm proved its suitability for that purpose. Strube² also has given numerical data on the manurial value of tar water, on the basis of exhaustive experiments; and these favourable results have been confirmed by the experimental station of the Halle chamber of agriculture.³

Nevertheless, in comparison with other commercial nitrogenous fertilizers, the value of this tar water is too small to bear the cost of transport or even of production; and it is supplied by the distillers to neighbouring farmers gratis.

In general the tar water is a troublesome burden to the lignite tar works, since only a very small proportion can be disposed of in the above manner, and, furthermore, the water cannot in its original condition be discharged as effluent into a watercourse, but must first be purified, so far as this is at all possible. Rosenthal⁴ has shown that chemical purification is out of the question, the water containing ammonia aldehydes, ketones, methyl alcohol, and acetonitrile.⁵ The same worker also detected the presence of various organic acids, such as acetic acid, propionic acid, butyric acid, valerianic acid, and also of pyrocatechin.⁶

The only way to purify this tar water is by mechanical treatment— aeration and filtration; ⁷ after which, and suitably diluted, it may be turned into the river. Another method of utilization consists in turning it on to the spoil heaps, where it quenches the hot ashes, the bulk of the water being then absorbed by the mass, whilst another small portion filters through and is purified during the process. In fact, the

¹ "Braunkohle," 4, 469 *et seq.*

² "Zeits. angew. Chemie," 1904, 1787.

³ Report for 1908, p. 71.

⁴ Report, 1 December, 1903.

⁵ Rosenthal, "Zeits. angew. Chemie," 1901, p. 665.

⁶ *Ibid.* 1903, 221.

⁷ Report of the Royal Chemio-technical Experimental Institute, Berlin, 25 March, 1904.

same degree of purification can be attained in this way as by the use of costly aerating and filtering plant.

Tar water is also used for damping the lignite fuel for the retorts, and for quenching the ashes from the grates. In many places, too, large collecting tanks have been constructed for evaporating the tar water.

Proposals to use tar water as boiler-feed water, or even for quenching coke, have had to be abandoned for obvious reasons connected with its composition and penetrating smell.

The tar water obtained from Messel coal comprises two portions : the small quantity already condensed previous to treating the vapours

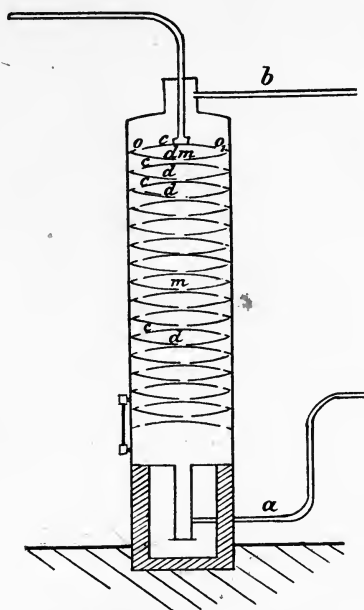

FIG. 29.—Tower still.

with acid (p. 40) ; and the larger amount deposited subsequent to the acid treatment. The latter is, naturally, free from ammonia, whilst the former contains the non-volatile ammonia salts and soluble distillation products such as compounds of ammonia with fatty acids, together with pyrocatechin and its homologues ; and this portion is subjected to further treatment. First of all, the ammonia is liberated by the addition of alkali, and is expelled in a column apparatus, the pyrocatechin and its homologues being then precipitated from the alkaline liquor by lead sulphate, whilst the residual fatty-acid salts are recovered by concentration. The pyrocatechin in the lead precipitate is recovered by treating it with sulphuric acid, concentrating the solution, extracting the concentrate with ether, and recrystallizing the ether

residue from benzol. The larger non-ammoniacal portion of the tar water is employed as stated on p. 41, under *b* (condensation).

The sulphate of ammonia recovered from the tar water is characterized by the entire absence of any excess of acid and cyanides, and enjoys a good reputation as a fertilizer.

Shale Tar Water.

Until 1865, the tar water produced in the Scottish industry was likewise regarded as a troublesome burden, and was discharged into water-courses. This liquor forms about three-quarters of the total dis-

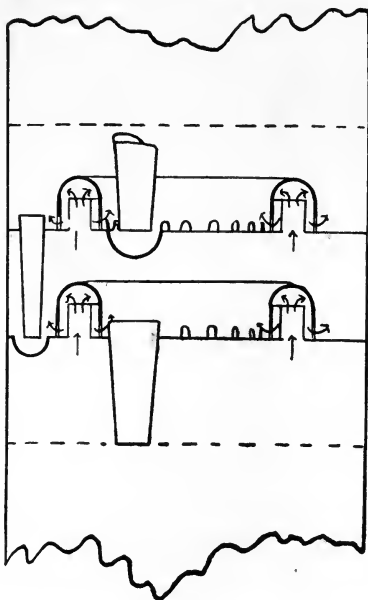

FIG. 30.—Henderson ammonia still.

tillate. It has the specific gravity 1.03 (4° B.) and, in addition to ammonia, contains pyridin and other organic bases. Robert Bell¹ of Broxburn was the first to treat the tar water for the recovery of sulphate of ammonia. The apparatus now used is, in general, the same as in large gasworks. The best results are obtained by the processes of Beilby² and Henderson.³

According to the Beilby process, the tar water is raised to boiling-point by direct steam in a tower still (Fig. 29) to expel the ammonia. Whilst the steam is admitted at the bottom through *a*, the tar water enters at the top through *b*, and is forced to describe a zig-zag course

¹ Redwood, "Mineral Oils and their By-products".

² "Chem. Technology," 2, 221.

³ D. R. Steuart, "The Oil Shales of the Lothians," Part III, p. 174.

by the baffles, *c, d, c, d*, flowing from the centre of the convex baffle plate *c* towards the rim, where it descends through the holes *o, o'* on to the concave plate *d*, and through the central hole *m* of this on to another convex plate *c*, and so on, until it finally reaches the bottom of the still, after being brought into intimate contact with the steam entering through *a*.

In the Henderson apparatus, illustrated in Fig. 30, a smaller quantity of steam is required. The tar water flows through a number of trays, connected together by gutters, as indicated by the arrows in the figure. The transverse compartments (usually ten in number) of the column are separated by specially arranged partitions. The steam is compelled to force its way into the water under pressure, and thus expel the ammonia.

The ammoniacal vapours are conducted into a vessel charged with sulphuric acid (cracker box), this acid being, usually, the waste recovered from the mixing process. The resulting solution of sulphate is concentrated, the sulphate of ammonia crystallizing out. Such of the ammoniacal vapours as have not been absorbed in the above vessel are passed into a second one, in which they are brought into contact with sulphuric acid of specific gravity 1.4, which ensures complete conversion into sulphate of ammonia; and this product separates out. The sulphuric acid is diluted with sulphate mother liquor, and occasionally waste acid.

The large crystals of sulphate first produced are dried by spreading them out in a warm room, whilst the smaller crystals afterwards formed are dried in centrifugal machines.

In order to obtain the purest sulphate of ammonia and a high yield, milk of lime is added in the concentrating pans to decompose the other nitrogenous compounds present and transform them into ammonia. The commercial article is only technical sulphate of ammonia,¹ but is sufficiently pure for use as a fertilizer. In some works, the mother liquors from the ammonia recovery process are concentrated in vacuum pans for further treatment.

The ammonia liquor furnishes 11 to 13½ lb. of sulphate of ammonia per ton of shale.

The utilization of the ammoniacal liquor is of the greatest importance to the Scottish shale oil industry; and if this product were not recovered, the distillation of shale would be altogether unprofitable at many of the works.

C. GAS.

The gas contains the bodies that have not condensed in the condensers. Its composition varies with the nature of the raw material and depends on the condition of the retorts and condensers. If these be air-tight and prevent the access of any air beyond that introduced with the charge into the retorts, the gas will have a maximum heating

¹ Mills, "Destructive Distillation," p. 20.

power and minimum of nitrogen content. The higher the latter, the lower the value of the gas, and a large proportion of nitrogen indicates the existence of leaks admitting air into the apparatus. By means of carefully conducted experiments, Gräfe¹ demonstrated that the carbon dioxide and hydrogen in the gas from the distillation of lignite in Saxon Thuringia mainly originate in the true coal substance of the raw material, whilst the bitumen in the latter forms the originating substance for the formation of carbon monoxide and methane homologues. These methane homologues are decomposition products and should be present in merely small amount if the distillation process be properly conducted, a high content of these bodies indicating an excessive retort temperature or unduly dry lignite. The steam in the retort protects the tar vapours from decomposition. If a lignite containing 50 per cent of water be used, 1 bus. of which yields 4 lb. of tar, there will be present in the retort about 80 per cent of steam, 19 per cent of gas, and 2 per cent of tar vapours.

According to Krey, 2 cwt. of lignite will yield 420 to 475 cub. ft. of gas. In the case of Scottish shale, Henderson gives the yield on gas per 2 cwt. of material, as 1000 cub. ft., and Bryson² as 1270 cub. ft. from the modern retorts, whereas the older pattern only furnished about 475 cub. ft. These high values are due, on the one hand, to the almost anhydrous raw material of the Scottish industry, and on the other hand to the circumstance that, in the present distillation process, the decomposition of the total carbonaceous matter in the distillation residue is secured.

The average composition of the gas from the Saxon-Thuringian retorts is:—

Carbon dioxide	10—20 per cent.
Oxygen	0·1—3 "
Heavy hydrocarbons	1—2 "
Carbon monoxide	5—15 "
Methane	10—25 "
Hydrogen	10—30 "
Nitrogen	10—30 "
Sulphuretted hydrogen	1—3 "

Gräfe³ ascertained the following composition, in which the high content of nitrogen and oxygen naturally depresses the remaining values. This large proportion of air is attributed to a leaky condensing plant:—

Carbon dioxide	8·9 per cent.
Oxygen	8·3 "
Heavy hydrocarbons	0·7 "
Carbon monoxide	6·2 "
Methane	6·4 "
Hydrogen	17·4 "
Nitrogen	48·0 "
Sulphuretted hydrogen	0·45 "
Hydrocarbon vapours	0·1 "

¹ "Braunkohle," Vol. IV, p. 383.

² "Journ. Soc. Chem. Ind.," 1897, p. 983.

³ "Braunkohle," Vol. IV, p. 382.

The calorific value of the gas obtained in the Saxon-Thuringian industry naturally fluctuates with the composition, and amounts to 2000 to 3000 cal.

The gas obtained from the new retorts used in the Scottish industry¹ has the following composition:—

Carbon dioxide	22.08 per cent.
Oxygen	1.18 "
Heavy hydrocarbons	1.88 "
Carbon monoxide	9.77 "
Methane	3.70 "
Hydrogen	55.56 "
Nitrogen	6.33 "

The remarkable feature in this case is the high proportion of hydrogen as compared with the gas obtained in the German industry. This is certainly due to the action of the steam on the carbon of the spent shale. The heating value of this gas is calculated as 2300 cal., and is lower on the average than the German gas, owing to the larger percentage of moisture.

An analysis, by J. Macadam,² of the gas obtained from the old retorts, shows a different composition, with lower percentage of hydrogen, viz. :—

Carbon dioxide	15.40 per cent.
Carbon monoxide	10.72 "
Methane	4.02 "
Hydrogen	34.53 "
Nitrogen	35.33 "

In both industries the gas is rarely used for lighting, but regularly for heating purposes in the retorts. This point has been fully discussed in the preceding chapter.

For some years, too, this gas has been employed for generating power in the Saxon-Thuringian industry. Rolle carried out the first experiments in this direction in the 'eighties, but without attaining any satisfactory result. The experiments were afterwards resumed by Krey, who, after prolonged exhaustive preliminary investigations, succeeded in making the gas useful as a source of power for industrial purposes. His endeavours were greatly assisted by the extensive improvements in gas-engine construction. At the present time, a number of motors, of 100 to 150 h.p., are driven by this gas for generating electric current for lighting and power.³

Previous to its application for the above purpose, the gas is freed from sulphuretted hydrogen in the same way as coal gas, and collected in a gas holder to compensate the fluctuating production. In the motor it is ignited by a magneto-electric device. On account of the contained air already alluded to, the gas is not readily inflammable.

¹ "Journ. Soc. Chem. Ind.," 1897, p. 983.

² "Journ. of Gas Lighting," 1893, 2, 399.

³ Glückauf, 1901, 410, Polyphase-current Plant at the Ottilie Kupferhammer Mine; A. Riebeck'sche Montanwerke, "Braunkohle," 1, 95.

The gas consumption in the motor amounts to 35 to 47 cub. ft. per h.p.-hour, and the volume produced by a retort in the same period is about 600 cub. ft., or about 14,000 cub. ft. in twenty-four hours, from the consumption of 95 to 110 bus. of lignite.

Numerous investigations have been made by Krey and his pupils into the chemical utilization of the gas, and the problem has been completely elucidated.¹ There is little prospect, however, of this utilization being practised on a manufacturing scale, the market prices of the products rendering the operation unprofitable at present. The sulphur of the sulphuretted hydrogen can be converted into sulphuric acid; and if this were generally done, a sufficient amount of acid to supply the demand for refining the oil would be produced. The carbon dioxide can be employed to decompose the soda tar, the sulphuretted hydrogen being also suitable for the same purpose.² Krey also succeeded in transforming the carbon monoxide of the gas into formic acid.

The hydrocarbon vapours in the gas can be recovered by scrubbing with tar oils. This treatment, though not employed in the Saxon-Thuringian industry is practised both at Messel and in Scotland. There the gas from the condensers is delivered by an exhaust fan into a coke tower (partially filled with gas coke), into the top of which vaseline oil is introduced through a pipe, and, falling on to a distributor, runs down in thin streams on to and between the layers of coke. The gas enters at the bottom of the tower and issues at the top, having been deprived of its hydrocarbon vapours. It is next passed through a receiver filled with water, to collect any contained particles of oil and absorb the ammonia; after which it is turned to account for heating purposes. The benzine is expelled from the vaseline oil by blowing the latter with steam, the oil itself being used over again as an absorbent.

A more recent practice in some works is to employ wooden lattice-work instead of coke, for distributing the scrubbing oil in the towers.

Coleman used another device for recovering the hydrocarbon vapours from the distillation gases, namely compressing the latter under a pressure of 6 to 7 atmospheres, accompanied by cooling down to -5° to -10° C., which ensured the deposition of the condensable constituents.

This method, however, was only in use for a short time, being soon abandoned on account of the expense; and at present the light benzine is generally recovered by the absorption method. This benzine has the specific gravity 0.700 to 0.715.

This method of recovery is impracticable in the Saxon-Thuringian industry, owing to the small amount of hydrocarbon vapours in the gas. As already mentioned, these vapours are formed as decomposition products in distillation, and their presence in larger amount in the gas

¹ W. Scheithauer, "Die Fabrikation der Mineralöle" ("Manufacture of Mineral Oils"), pp. 90-91; Gräfe, "Braunkohle," 4, 385.

² E. Erdmann, Ger. Pat. 132,265.

from the Scottish retorts is explained by the higher working temperature in these latter.

At Messel, the distillation gas is utilized in the following manner: The largest portion (70 to 80 per cent) is employed, without purification, for heating the retorts. Another portion serves the column apparatus of the oil scrubbers (see p. 41), and still another portion is used for raising steam in the boilers.

The remainder of the gas (about 20 per cent) is employed for driving gas engines, after having been freed from sulphuretted hydrogen. The Messel Co. recognized, from the first, the importance of the gas engine, and made use of it as a source of motive power. This works was undoubtedly the first to utilize the impure, inferior gas for generating power, and led the way to the general application of waste gas for driving engines. The first small waste-gas engine was set up in 1886, and was afterwards followed by a large number of larger ones, so that at the present time the gas-engine power at the works is about 1500 h.p., though, in contrast to the earlier practice, the gas is now freed from sulphur before reaching the engines.

Plant for eliminating carbon dioxide from the gas, in view of applying the latter for lighting purposes, is in course of construction. The gas differs from coal gas by the feature, common to all dry-distillation gases, that its carburation is due to the presence of vapours of readily volatile hydrocarbons of the fatty series, and when freed from carbon dioxide—of which it contains up to 30 per cent—it furnishes an illuminating gas which burns with a very bright flame at ordinary temperature.

D. THE DISTILLATION RESIDUES.

We have seen that, in the Scottish industry, the watery liquor forms an important source of income, whereas it is worthless in the Saxon-Thuringian industry. In the case of the distillation residues, however, the conditions are reversed. In Scotland the spent shale, after having done good service in increasing the percentage of ammonia in the watery liquor, is of no value; but in the Saxon-Thuringian industry, on the contrary, the coky residue is as important as the ammoniacal liquor in the Scottish process. In fact, when the prices of tar products are low, many distilleries would be working without profit, were it not for the income derived from the coke.

This coke is of granular character, and is sold in the condition in which it occurs after quenching, namely with about 20 per cent of moisture. The ash content, which depends on the raw material, is about 15 to 25 per cent (when the moisture is 20 per cent), apart from which it consists of pure carbon. Consequently its calorific power is high, varying between 6000 and 7000 cal., according to the percentage of ash.¹ The granular character is regarded as an important feature, since, if too dusty, its value as a heating agent is impaired.

¹ "Braunkohle," 5, 783.

It is only since about the middle of the 'seventies that the coke has found general application for heating, having previously been removed direct from the retorts and tipped on to spoil heaps, where it continued to burn away for the most part, the remainder being used for road mending. Heaps of this kind are still to be found on the sites of abandoned works.

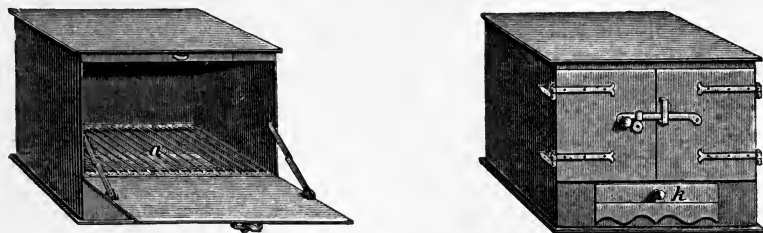

FIG. 31.—Lignite-coke cookery stoves.

The coke is burned in special stoves, one of which, of a simple character, is shown in Fig. 31. The coke is placed under the grid *a* where it burns slowly, the cooking utensils being heated on the grid. A stove with two stages is illustrated in Fig. 32. The food is cooked

on the grid in the lower compartment, and is warmed on a plate in the upper one. The draught in the stove is regulated by means of a damper *k*, and the ash is collected in the ash box *a*.¹

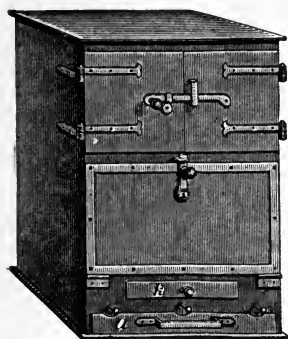

FIG. 32.—Two-stage coke stove.

but also find employment in large agricultural establishments, cabinetmakers' shops (for boiling glue and drying glued articles), and for heating workshops. They are, however, restricted to certain districts, chiefly in the towns of Magdeburg, Brunswick, Dessau, Leipzig, and the vicinity, whereas they are rarely found in the lignite districts, other fuel being cheap there. On the other hand, they are gaining ground in other parts of Germany, and are readily purchased as soon as their advantages are realized.

The bulk of the coke is sold as fuel, only a small proportion being used for other purposes. Coke with a low percentage of ash, and deep black in colour, such as is furnished by lignite poor in bitumen,

¹ Stoves with improved side and top heat have recently been introduced by the Hannoversche Grudeöfenfabrik Hermann Tanzer, G.m.b.H., Hanover.

is ground fine and used in the preparation of black pigments (Frankfurt black). In metallurgy, the coke is used as a reducing agent for zinc.¹ It also makes a good filtering medium, and is used as such for drinking water and in purifying effluent waters, for which purpose it is superior to ordinary coke (Ger. Pat. 150,362). It may also be used for eliminating iron from water, having, like other porous forms of carbon, the property of precipitating the iron.

To a small extent, too, this coke is used in making compressed block fuel² which product has been successfully used for some years in heating passenger carriages on secondary railways. The coke being devoid of bitumen must be mixed with a dextrinous binding medium before pressing.

So long as this coke continues to find a sufficient outlet in its original form, there is no need to consider the suggestion that it should be made into briquettes on a large scale, or mixed with lignite for the production of block fuel or briquettes.³

At Messel, the distillation residue is unutilized, except for such portion as is in demand by makers of stove polishes. Its application in the retorts has already been mentioned. It is sold to the stove polish makers in a perfectly dry condition, and, owing to the high percentage of mineral matters, it does not give rise to dust explosions.

The mineral residues obtained in the Messel industry are divided into a loose, slaty ash of extremely porous structure, and a hard, porous clinker. The first named is mixed with lime to make artificial bricks, which are similar in appearance and use to those made from Rhenish sand. The clinker is of two different qualities: the one, produced in the boiler fire-boxes, is not very firm, and is largely used in making concrete ceilings, whilst the other, though of lower specific gravity and very spongy character, is much harder and of greater tensile strength. This grade is formed by the sintering together of the carbonaceous residues on the spoil heaps. When cold, the mass is quarried out in blocks, several cubic yards in dimensions, and broken down into small lumps, which are used for building purposes, especially where capacity to resist moisture and frost is required.

¹ "Freibergs Berg and Salinenwesen," p. 315.

² The annual production is about 60 tons.

³ "Zeits. f. d. Paraffin-, Mineralöl- u. Braunkohlenindustrie," 1875, 34.

CHAPTER V.

THE DISTILLATION OF THE TAR AND TAR OILS.

As already mentioned, the dry-distillation tars are passed on to the mineral oil and paraffin plant after having been freed from water, as far as possible, in the collecting tanks at the distillery plant. They are run out of the tank cars into large iron or cement tanks, in which an average quality product is thus collected. Owing to the fact that the tar solidifies at ordinary temperature, it has to be conveyed through pipes that are heated by steam. The operations in this plant are classed under three heads: (1) distillation, (2) chemical treatment of the tar and distillates, and (3) the production of paraffin, which divisions will now be dealt with in the order named.

A. THE DISTILLATION PROCESS.

Three systems of distillation are practised: under ordinary atmospheric pressure, in a partial vacuum, and by steam; in addition to which, mention must be made of continuous distillation and distillation under pressure.

The object of each of these processes is to decompose the raw material into its fractions of different boiling-points and its paraffin, by the application of heat and by condensing the resulting vapours. In distillation at ordinary atmospheric pressure, the decomposition of the raw material is accompanied by the formation of a cokey residue (retort coke), the decomposition being more extensive than when the operation is carried on in a partial vacuum. In this latter case the distillation temperature is lower on account of the diminished pressure, and the resulting vapours are less exposed to decomposition. In steam distillation the same effect is obtained by the introduction of steam, which envelops the distillation vapours and protects them from decomposing.

These methods of distillation are carried on by distilling-off the charge in the still, and collecting the various constituents of the raw material in succession in a condensing plant. If the apparatus be arranged in such a manner that fresh quantities of the charge are introduced without intermission, and that the individual fractions are condensed and drawn off simultaneously at different parts of the cooling plant, we then have continuous distillation.

The process of distillation under pressure consists in decomposing

the vapours of heavy oils under a given pressure—a process which must not be confounded with “cracking,” i.e. the decomposing of the oil vapours by superheating.

Details of the processes will be found with the description of the various forms of apparatus.

B. TAR DISTILLING IN THE SAXON-THURINGIAN INDUSTRY.

The Distilling Apparatus.

The apparatus consists of the stills or retorts, and the condensers in which the condenser worms are housed. Similar appliances are used in the distillation of coal-tar and the spirit industry.

The retorts are generally of cast iron, and more rarely of wrought iron, but the cast-steel retorts used experimentally by Krey did not prove satisfactory. As a rule the retort, when filled to two-thirds its

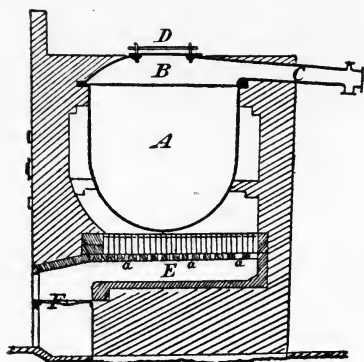

FIG. 33.—The retort.

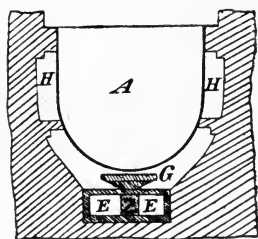

FIG. 34.—The retort
(front view).

capacity, holds 450 to 550 gal. of tar or oil. Cast-iron retorts of larger size than this are not used, and those of wrought iron are only found in a few works. The shape of the retort can be seen from Figs. 33 and 34, the dimensions being about : height, 5 ft., width, 5½ ft. at the top. The cast-iron cover B is bolted on to the flange of the retort A, and a tight joint is established. The cover has a spout C about 20 in. long, and of oval section, for the discharge of the vapours. In the centre of the cover is a manhole D 20 to 24 in. across, which is closed by a bow and wedges when the apparatus is in operation.

The retorts are bricked round in various ways, the object in all cases being the same, namely to utilize the heat as fully as possible whilst protecting the retort—and the bottom of same in particular—from direct contact with the fire. The portion of the brickwork most exposed to heat is built of firebrick, to make it more durable. The flames pass from the grate F towards E under the retort, and after being divided by the partition Z are broken up by a bridge forming eight slits *a, a*. These slits are widened in the rearward direction, so

as to enable the flame to spread evenly. The bottom of the retort is protected from the direct impact of the fire by a shield *G* mounted

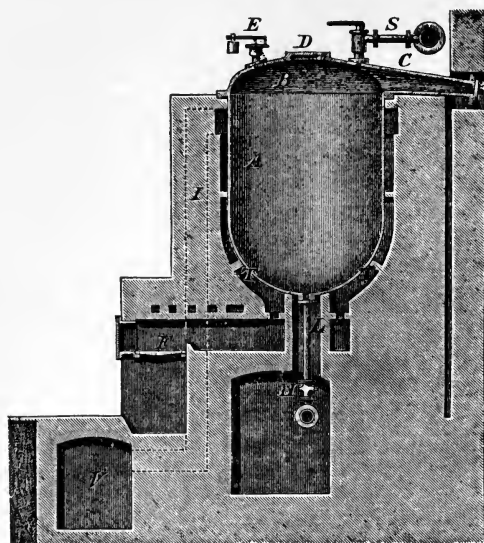

FIG. 35.—Retort for partial vacuum distillation.

on the partition, the hot gases issuing from the slits then flowing round this shield on their way to the bottom and upper portion *H* of the retort.

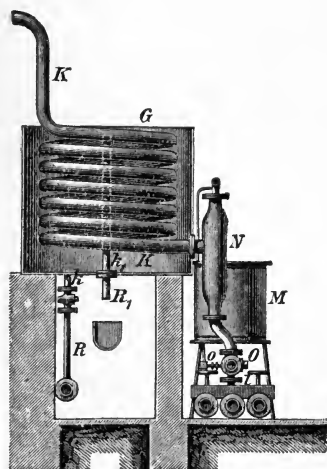

FIG. 36.—Distillate receiver.

the grate *F* through slits to the retort. Brick ribs, built into the wall, support the retort; and the hot gases, after bathing the walls, pass

The above-described apparatus is used when, as is frequently the case, the distillation is conducted under ordinary atmospheric pressure. If, on the other hand, a partial vacuum is used in distillation, a retort of the type shown in Fig. 35 is employed. This retort *A* is of the same shape, but is provided at the bottom with a 3-in. opening, fitted with an external flange on to which is screwed a pipe *L* connected with a main by way of a tap *H*. The pipe *L* is protected from the fire by a fire-brick cylinder. The brickwork of this retort is arranged on the same principles as already described; and the flames draw from

away through a flue J to the main flue V, and thence to the smoke stack. E is a safety valve attached to the retort, and blowing off when the pressure exceeds about $7\frac{1}{2}$ lb. per sq. inch.

The spout C of the retort is connected with the condenser worm K, as shown in Fig. 36. K is about 27 yd. long and is made of leaden or iron piping. With the latter material, the coil is formed of either coiled gas-piping or else of cast-iron tubes—semi-circular segments with flanges. The worm is situated in an iron cooling tank G, and is cooled with water introduced at the bottom of the tank and removed at the top. In the drawing, Rk represents the intake pipe and R'k' the delivery surface, per retort, is about 85 to 95 sq. ft.

When distillation is effected at atmospheric pressure, the oil condensing in the worm flows, as shown in Fig. 37, into a small vessel H

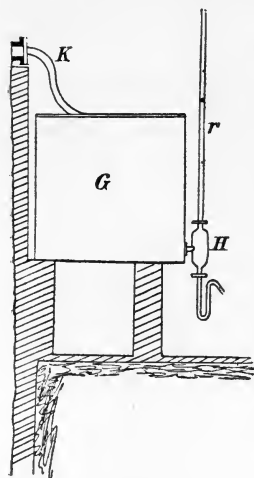

FIG. 37.

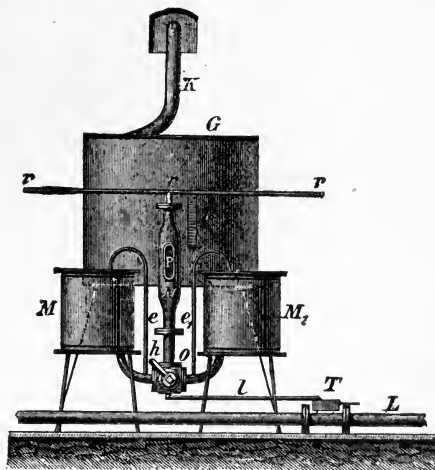

FIG. 38.—Distillate receiver.

serving as a gas trap, from which it is conveyed through adjustable funnels into pipes leading to the various collecting tanks. The uncondensed gases escape through the delivery pipe r into the outer air, or else are collected in a gasholder for further use.

For distillation in partial vacuo, the apparatus is provided with a suction device, acting at the end of the condenser worm (receiver), and reducing the pressure inside the retort. For this purpose either a Koerting injector or an air pump is employed, both of which forms have been found suitable. The apparatus used for this method of distillation in different works are all the same in principle though varying in character. The form shown in Figs. 36 and 38 is that used at the Webau works of the A. Riebeck'sche Montanwerke. At the end of the condenser worm K is mounted an elongated casting provided with a glass window P and closed by means of a 4-way tap O communicating with the receivers, M and M', through lateral tubes. Each receiver has a

capacity of 33 gal. To the upper end of the casting N is screwed a pipe *r* leading to a Koerting injector which sets up a partial vacuum in the retort and alternately in the receivers (viâ the tubes, *e* and *e'*). A mercury vacuum gauge V, connected with the retort by a narrow tube, indicates the extent of the vacuum produced. The main tap O is also connected with a smaller 4-way tap *o*, controlling the communication between the receivers and the injector. When this communication is closed the receiver is open to the air. If, for instance, the lever *h* of the tap O be turned in the position shown in Fig. 38, then the receiver M is closed with reference to the casting N, whilst its delivery pipe is opened and is placed in communication with the outer

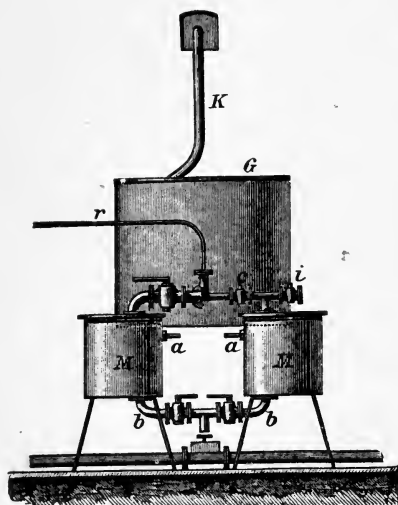

FIG. 39.—Distillate receiver for lignite tar.

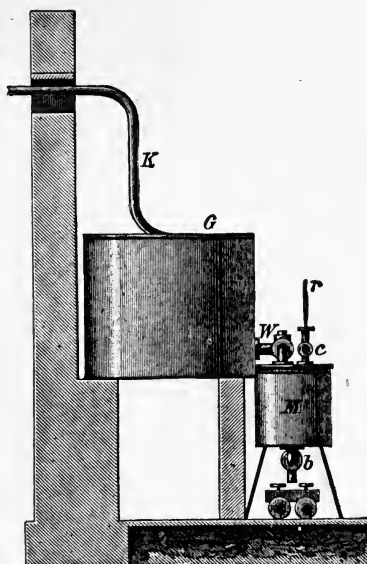

FIG. 40.—Distillate receiver for lignite tar.

air by way of the tube *e*. The distillate runs out of M through the pipe *l* to the funnel T and into the pipe L. At the same time the receiver M' on the other hand is placed in communication with the casting N, and through *e'* with the injector. The distillate from the condenser worm runs away to M'.

By means of the window P one can see when either of the receivers is full; and the lever *h* has then merely to be turned over, to divert the distillate into the other receiver, and empty the full one.

Owing to the tendency of a portion of the distillate to congeal in the narrow casting N, the above apparatus is less suited for the distillation of lignite tar and the oils rich in paraffin than it is for the oils. When lignite tar is being treated, the casting N is omitted, and the distillate is led direct into the receiver, as shown in Figs. 39 and 40.

In this case the condensing coil K terminates in a 3-way tap W, the other two branches of which are connected with the two receivers MM, provided with a T-piece and taps *c, i*. The Koerting injector draws at *c* through the pipe *r*, and communication with the outer air is established through *i*. The receivers are used alternately as in the preceding arrangement. In the one a partial vacuum is set up and the distillate flows through the opened connecting tap, whilst the distillate flows out of the other by way of *b* when *c* has been opened and the tap communicating with the condenser has been closed. At the upper rim of each receiver is a gauge glass *a* which shows when the vessel is full.

The gases drawn off by the injector are led through a cooler, where they are freed from accompanying water vapour. This done, they are conducted away for utilization—as described later—or allowed to escape into the open air.

To facilitate the more accurate separation of the individual fractions of distillate, in the case of the more volatile tar oils, the retorts are provided with superimposed column apparatus, 3 to 6 ft. high, similar to those used in the rectification of spirits, and fitted internally with perforated trays.

The Distillation Process.

In distillation at ordinary pressure, the retort is charged with tar or oil through a pipe introduced through the manhole. The terminal length of this pipe is adapted to swivel on the main pipe, so that it can be turned round and serve two retorts in succession. In the main supply pipe, the material is either moved forward by the action of compressed air from a storage vessel, or else pumped, unless—which is the simplest plan—it descends from a high-level tank by gravitation. The retorts are charged to two-thirds their total capacity.

If the tar has been subjected to chemical treatment before distillation, about $\frac{1}{4}$ to $\frac{1}{2}$ per cent of slaked lime is added to the charge. In some works, solid caustic soda ($\frac{1}{4}$ to $\frac{1}{2}$ per cent) or soda lye, is added to the oils before distillation. At one time, other adjuncts, such as manganese oxide or bleaching powder, were used. The object of adding these agents is to combine the sulphuretted nitrogen liberated, and also to lessen the percentage of creosote in the distillates.¹ As a matter of fact, the amount of creosote is slightly reduced, and the smell of the distillate is somewhat improved; but the sulphur content is left untouched.

As a rule the retorts are distilled to dryness, that is to say until a solid residue of coke is left. More rarely, only three-quarters of the charge is distilled over, the residue in a number of retorts being transferred, when cold, to a special retort and there distilled to dryness. Though this latter method preserves the retorts, it is too troublesome, and is therefore seldom employed.

¹ Krug, "Hübners Zeits. f. d. Paraffin-, Mineralöl- u. Braunkohlenindustrie," 1878, 32.

When distillation is completed, the coke is removed from the cold retorts, by the aid of broad iron tools and shovels introduced through the manhole. Between successive distillations the condenser is cleaned by a blast of steam introduced about the middle of the spout.

A charge of 2 to 2½ tons of tar or oil usually takes about nineteen hours to distil, and consumes on the average 27½ bus. of lignite for heating the retort. Each retort is filled afresh daily, and distillation is completed by the evening, so that no night shift is worked. One stoker will serve eight to ten retorts, and a distiller, who sees to the progress of the distillation and the bestowal of the distillates, has to supervise fourteen to sixteen retorts.

The first vacuum still apparatus in the lignite-tar industry was used by Krug, though Wagemann¹ had made experiments in this direction in the early days of the industry. Krey employed the method on a larger scale, by equipping the three mineral oil works of the A. Riebeck'sche Montanwerke for vacuum distillation in 1884, and elaborated a system which led on the one hand to the abolition of cleaning out each retort, and on the other enabled each retort to work three charges (with a night shift) in twenty-four hours. The only retorts to be cleaned out regularly were those receiving the residues from the other retorts. It is evident that this method of working—which was already employed in the coal-tar and stearine industries—can be operated with a far smaller number of retorts than the others.

The closed retorts are charged by a charging pipe S (Fig. 35) passing through the cover; and at the same time the Koerting injector acts at the other end of the system, in order to accelerate the charging process. Ten retorts can be charged in as many minutes. Measuring devices inserted through the retort cover enable the height of the charge to be ascertained.

During distillation the injector is regulated so that, at the commencement, the reduction in pressure is very slight, it being advisable to allow the first distillate to undergo a certain amount of decomposition. The vacuum is then gradually increased, and, as soon as the distillate containing paraffin begins to come over, the vacuum is raised to 16 to 20 in. mercury gauge. In this way decomposition of this valuable constituent is prevented. The desired three-fourths of the charge will have distilled over in six to seven hours; and the residue, after being allowed to cool down for about an hour and a half, is drawn off from the retort by opening the tap H. The residues are collected in an iron tank or cemented pit, and are afterwards distilled to dryness in special retorts unprovided with any draw-off cocks, the coke being removed in the usual manner.

The main retorts are refilled and started again; and fifteen to sixteen charges can be worked in a week, night shifts included. At the end of two to three weeks, the retorts are opened to clean out the small quantities of coke and soot that have accumulated.

¹ Dingler, 139, 43.

The consumption of fuel, including the heating of the residue retorts, amounts to 22 to 25 bus. of lignite per 2 tons of raw material; and the number of hands required is the same as in the other method.

Distillation in a partial vacuum has many advantages over the ordinary-pressure method. There is a saving in fuel, the operation being continuous—except for short periods of interruption—all through the week, so that the capacity of the apparatus is fully utilized. New plants should preferably be equipped for vacuum distillation, though in the case of small works, treating about 5000 tons of tar per annum, there is no pressing necessity for remodelling the existing plant, since, when carried out with care, the old method presents, for these small plants, advantages that compensate those of vacuum distillation, from the economic standpoint.

The steam-distillation process is also employed in the Saxon-Thuringian industry. During the process the steam is either admitted into the upper part of the retort, above the charge, so as to protect the vapours from decomposition and accelerate their passage to the condenser; or else—the more frequent practice—is led down to the bottom of the vessel and allowed to ascend through the charge. If necessary, the steam is superheated in advance, especially when no high-pressure steam is available. The steam-distillation process, however, is usually restricted in application to two special contingencies, namely, on the one hand to raising the flashing point of the oil by expelling the more volatile fractions, and on the other to distilling oils of low specific gravity. In such cases the direct heating of the retorts is dispensed with, and a closed steam coil is fitted. Gilled pipes, connected with steam traps, are preferably used on account of their larger heating surface. The oil is heated by the steam pipe, and at the same time superheated steam is introduced into the bottom of the retort.

In rare cases, steam distillation is employed as an auxiliary to vacuum distillation.

Continuous distillation has only been introduced in the Saxon-Thuringian industry within the last few years. It is true that for several years in the 'eighties, C. A. Riebeck employed a French continuous process¹ for working up the light crude oil constituting the first fraction from the distillation of tar; but the results were so little satisfactory that the process—which was really suitable only for petroleum distillation—was abandoned.

In 1907, E. Wernecke, manager of the Sächsisch-thüringische A. G. für Braunkohlenverwertung, took out a patent² for a continuous-distillation apparatus, which is illustrated in Fig. 41. Here A is the conical still, fitted at the top with a hood B, and at the bottom with

¹ Scheithauer, "Die Fabrikation der Mineralöle" ("Manufacture of Mineral Oils"), p. 115.

² Ger. Pat. 201,372. Continuous still with direct heat and internal pockets for the charge. The apparatus is made by the Deutsche Industrie-Maschinen G.m.b.H., Magdeburg.

a cylindrical attachment C. From the grate *f* the hot gases flow through flues *e, e*. The raw material is introduced through the charging pipe *a*, after traversing a preliminary heater. Pockets *t, t* composed of well-fitting iron rings, are provided to receive the charge, which overflows from each ring on to the one below. When all the pockets have been filled, which will be the case when the raw material begins to run out through the draw-off pipe *d*, the heating is commenced. The neck *b* of the hood B forms the upper exit for the gases and vapours of the lighter fractions, whilst the vapours of the heavier constituents escape through *c*, which carries a wire-gauzecore and shield D adapted to be raised or lowered with relation to the

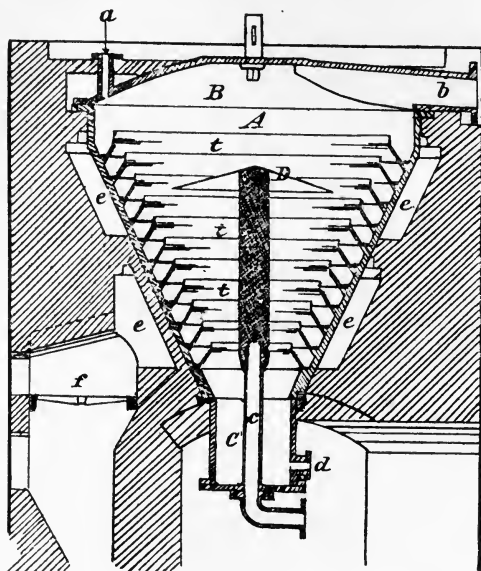

FIG. 41.—Continuous distillation apparatus.

pipe *c*. The residue is drawn off through *d*. All the discharge pipes are connected with condensers. Since the distilled vapours do not come in contact with the heated walls of the still, they are protected from decomposition. Distillation proceeds in a partial vacuum, produced by means of an air pump.

The still can be run for some considerable time without having to be cleaned out; and this operation is easily performed, the pockets being removable.

Young was the first to recover lamp oils from heavy mineral oils by distillation under pressure.¹ For example, he obtained 54.2 per cent of lamp oil from an oil of specific gravity 0.902, and 48.4 per cent from one of specific gravity 0.918. Independently of these experiments,

¹ "Chem. News," 1869, 182.

which had remained unknown, or had been forgotten in Germany, Krey succeeded, after numerous attempts, in converting the heavy vaseline oils from lignite tar into lamp oils, in 1887. The impetus to these researches was given by the fact that, at the time, the market

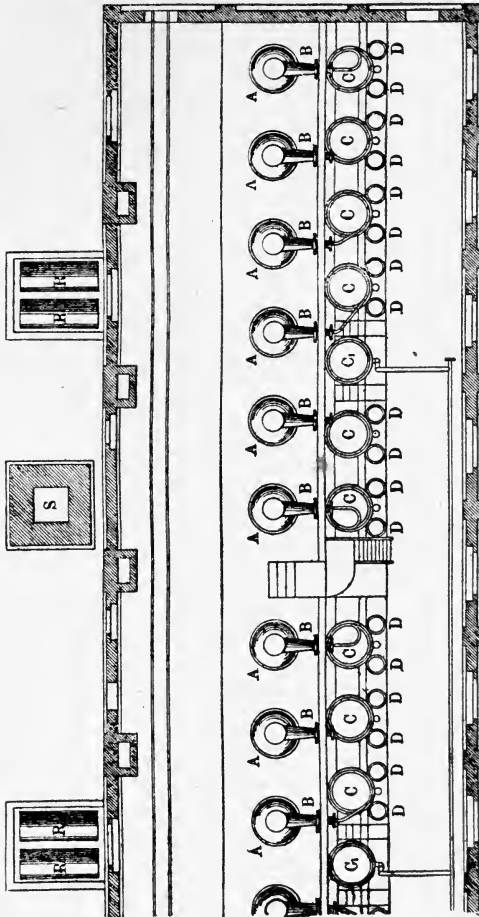

FIG. 42.—Plan of distillation plant.

was overburdened with these heavy oils, which were difficult to dispose of. Krey protected his method of pressure distillation by patent (Ger. Pat. 37,728).¹

The essential feature of the process consists in decomposing the vapours of heavy oils under a definite pressure, in a smaller pattern of the ordinary retort, combined with a cooler. A valve interposed be-

¹“Jahresber. des Techniker-Vereins d. sächsisch-thüringischen Mineralölin-dustrie,” 1887.

tween these two vessels enables the liberated vapours to pass to the cooler only so long as the prescribed pressure is maintained, the valve being adjusted to the desired working pressure. One and the same

heavy oil, distilled at a pressure of 6 atmospheres, will furnish a lamp oil of lower specific gravity than if distilled under a pressure of 2 atmospheres. The heavier the pressure, the larger the volume of gas disengaged, and the more extensive the decomposition of the charge. The pressure distillate always contains large quantities of dissolved gas, which must be expelled by means of an air blast before the oil is subjected to chemical treatment.

The continued fall in the price of the lamp oil (solar oil) from year to year, until it has approximately reached that of the heavy vaseline oil, has prevented the method from being applied on an extensive scale. By the aid of pressure distillation, Engler demonstrated the animal origin of petroleum, a perfect lamp oil having been produced from low grade waste materials, such as stearine pitch and petroleum residues.

It should also be mentioned that, simultaneously with Krey, Bentre¹ obtained a patent in America for converting heavy oils into light fractions by distillation; and the same process was patented in 1889 by Dewar

and Redwood.² In this case air or carbon dioxide is forced into the still, and the operation is carried on under that pressure.

The Distillation Plant.

A number of stills, about 6 to 15, are united to a battery by being mounted in the same brickwork setting, and provided with a common

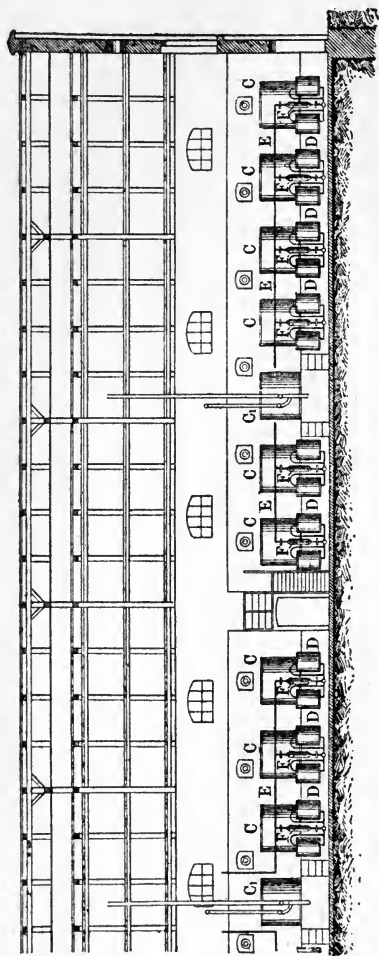

FIG. 43.—Distillation plant: distiller's platform.

¹ "Chem. Technologie," pp. 205 et seq.

² Ger. Pat. 53,552.

platform for the stoker and distiller. One large battery or several smaller sets may be housed in a roofed-in building. In contrast to the arrangements in the Scottish industry, all the buildings in the Saxon-Thuringian industry are walled-in and provided with roofs of millboard or corrugated iron—more rarely of brick. As a rule the stoker's platform is isolated from that of the distiller in a fireproof manner. An up-to-date distillation plant is illustrated in Figs. 42, 43, and 44, which represent a portion of the plant at the Webau works, of the A. Riebeck'sche Montanwerke. Fig. 42 is a plan, Fig. 43 shows the distiller's platform, and Fig. 44 a cross section through the build-

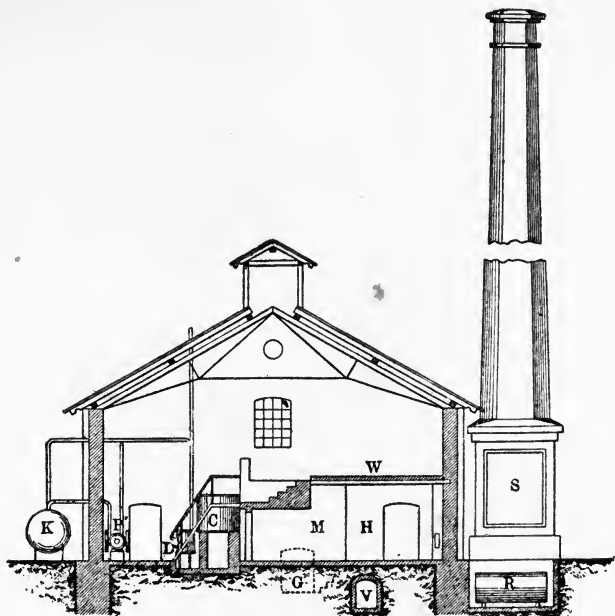

FIG. 44.—Cross section through distillation plant building.

ing. A is the retort, B the spout or neck of same, C the condenser, F the intermediate casting, and D, D are the receivers into which the distillate flows and to which the Koerting injectors are connected by means of the pipe E. C is the cooling device for the injector, whence the gases are forced by the pump P to the gas tank K, and thence to the gasholder. R, R are the stills for treating the residue, which flows into them, from the main stills, through a pipe situated in the vault G. M is the brickwork setting of the stills; H is the stoker's platform, which is separated from the upper part of the stills in a fireproof manner by means of the corrugated iron roof with clay lagging W. An iron stairway leads from the distiller's platform to W. The flue gases

escape through V to the smoke stack S. Sufficient ventilation is provided for the room by suitable roof construction.

The Distillation Products.

The products resulting from the distillation of lignite tar are crude oil and A-paraffin mass (or hard-paraffin mass), and the separation of these two members ensues as soon as the distillate solidifies by contact with ice or with a cooled object, such as iron plate. The final portion of the paraffin mass is of greasy character and red colour; it is collected separately, and is known as red product. In some works, however, a small quantity of a substance termed paraffin grease is separated previously to the red product. Coke is left behind in the still, and permanent gases are given off during the distillation process, especially towards the end.

Lignite tar of medium specific gravity (0.870 to 0.880) furnishes on distillation:—

	Small quantities of water.
	33 per cent of crude oil.
60	" " " paraffin mass.
2	" " " " grease.
1	" " " " red product.
2	" " " " coke.
2	" " " " permanent gas.

The water is valueless.

The crude oil has about the same specific gravity as the original tar, and is dark brown in colour. It boils between 100° and 350° C.

The A-paraffin mass is subjected to chemical treatment, unless the tar was so treated previous to distillation. It is then cooled down in a special chamber, for the separation of the paraffin, and pressed, yielding under this treatment 15 to 20 per cent of hard paraffin scale and A-filter oil.

The paraffin grease contains but little paraffin, and this is non-crystalline in character. The grease is sold as such.

The red product also contains little paraffin. Like the paraffin grease it chiefly represents decomposition products. It is returned to the tar for redistillation, and, so far as experience goes, without increasing the amount of red product obtained in the succeeding distillation.

The coke is utilized as fuel, though when the distillation is carried on without adjuncts, it finds employment for electrical purposes, but must first be freed from final traces of contained hydrocarbons by calcination. The heating value of the coke is 8000 to 8500 cal.

The permanent gases were formerly used for lighting and heating, when collected at all.¹ A few years back, however, Krey turned this gas (like that from the dry-distillation process) to account for generating power in gas engines; and several engines, operated in this manner, are running. Before use, it must be freed from sulphuretted hydro-

¹ "Braunkohle," 5, 561.

gen in the customary manner. The heating value of the gas averages 7000 to 8000 cal. ; and the consumption per h.p. hour amounts to 12 to 18 cub. ft. It is preferred to use only the gas liberated during the distillation of the oils containing paraffin (paraffin mass), the other distillation gases being far inferior in heating value.

According to Gräfe,¹ the gas has the following composition :—

Hydrocarbon vapours	3.0 per cent.
Sulphuretted hydrogen	3.2 "
Carbon dioxide	2.4 "
Heavy hydrocarbons	6.8 "
Oxygen	3.4 "
Carbon monoxide	1.9 "
Hydrogen	4.9 "
Methane	28.5 "
Ethane	32.2 "
Nitrogen	remainder.

The following Diagrams I and II represent the products obtained by the distillation of lignite tar. They differ in certain points of detail, such as the nomenclature and separation of the individual sub-fractions, but are both based on the fundamental idea of separating oil as free as possible from paraffin from the paraffin masses, and concentrating the recoverable paraffin as much as possible in these masses. At the same time an improvement in the colour and smell of the commercial oil products is sought to be attained by the distillation process.

The crude oil, after being put through a chemical treatment, is separated by distillation into one or two oil fractions and a paraffin mass. The separation of the oil and mass takes place as soon as the distillate is congealed by ice. As shown in Diagram II, two oil fractions, separated according to their density, are obtained from specifically light tars, before the mass. The lighter oils furnish lignite-tar benzene, solar oil, and pale vaseline oil.

Since the distillation according to Diagram I is simpler than the other, it will be used as the basis of the following description.

The B-paraffin mass is soft, and is rendered available for use either by the employment of refrigerating machinery, or by crystallization in the winter. This treatment will be described in the chapter on Paraffin Manufacture.

The crude solar oil has the specific gravity 0.830 to 0.840 and is light brown in colour. As a rule it is subjected to chemical treatment before distillation. In the still it is separated into lignite-tar benzene, solar oil, pale vaseline oil, and solar paraffin mass.

The benzene has the specific gravity 0.790 to 0.810, a flashing point of 25° to 35° C. and a boiling-point between 100° and 200° C. The colour is faintly yellow. It is used up in the works as a scrubbing oil in the manufacture of paraffin ; but is generally separated beforehand into several fractions by redistillation assisted by steam.

The solar oil and pale vaseline oils (cleaning oil, yellow oil) form commercial products, and are dealt with fully in Chapter VIII.

¹ "Die Braunkohlenteer-Industrie," p. 52.

On pressing, the solar-paraffin mass furnishes solar-paraffin scale and gas oil, which is also a marketable product.

The A-paraffin mass yields in addition to A-paraffin scale, an A-filter oil, which is occasionally treated chemically previous to distillation. As a rule this oil is not distilled to dryness, but only until about 5 per cent of residue is left. The distillate consists of crude oil (which is united with that from the tars) and B-paraffin mass, which is worked up along with that from the crude oil. The residue is a tar, resembling coal-tar in appearance, and sold as "goudron".

The B-filter oil obtained in working up the B-paraffin mass to B-scale is decomposed by distillation into a red oil (gas oil) as free as possible from paraffin, and into C-paraffin mass. The red oil is a commercial article, and the C-paraffin mass is worked up, after cool-

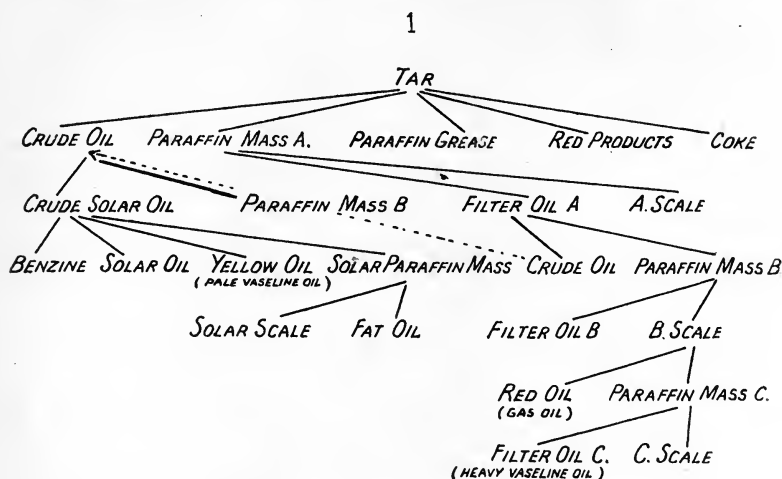

DIAGRAM I.—Products obtained by the distillation of lignite tar.

ing, for C-paraffin scale, C-filter oil being obtained in the process. This oil, which should contain only a minimum quantity of recoverable paraffin, is sold as heavy vaseline oil, 0.900 to 0.920.

Diagram II shows that A-paraffin mass is sometimes called hard-paraffin mass, and the B- and C-paraffin masses are also known as second-grade and third-grade masses. The A-filter oil is termed heavy crude oil. Reference has already been made to the variations in nomenclature and definition.

In the recovery of the individual fractions, the condition of the market has also to be borne in mind, according as the non-paraffin oils are destined for purposes making special requirements in respect of specific gravity, flashing point, colour, and smell.

The distillation of the press oils remains to be considered. As will be seen from the subsequent description of the process of manufactur-

ing paraffin, these oils consist of the light lignite-tar oils used for scrubbing, and of the mineral oils adhering to the crude paraffin and whose elimination is the object of pressing. The benzine is recovered from the press oils either by distillation with the aid of steam, the residual paraffin mass being afterwards cooled, or else the press oil is cooled direct. The oil obtained from the press oils in the pressing process is separated by distillation into benzine, or crude solar oil, and a paraffin mass.

The Retorts.

It has already been stated that small cast-iron retorts are used in most works. When distillation is conducted to dryness, at ordinary atmospheric pressure, these retorts are worn out in about six to eight

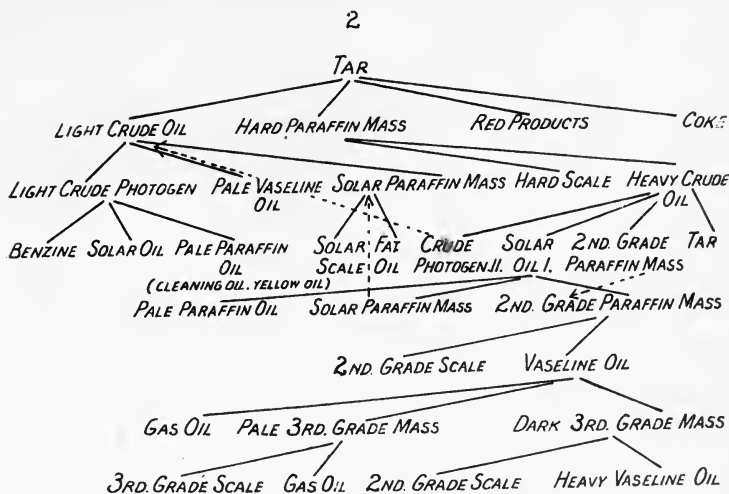

DIAGRAM II.—Products obtained by the distillation of lignite tar.

months; but with vacuum distillation, the only retorts subjected to extensive wear are those in which the residues are distilled, whereas the others have a much longer working life, the tar retorts lasting six to eight years and the oil retorts more than ten years. All cast-iron retorts, even when carefully selected, are liable to crack after a certain time, if they have been strongly heated, such cracking, however, being found by experience to be due to cooling and not to heating. Consequently, particular attention must be bestowed on this point.

It is impracticable to stop up the cracks, or to close them by electrical welding, the only way to repair them being to cover them with patches of cast iron 1 to 1½ in. thick, applied to the outside of the cleaned retort and well cemented. If this operation be carefully performed and the retort mounted so that the patch is not in direct contact with the fire, it will not break again at the same place, and the

patch will stick on well. For every 100 lb. of tar worked up into marketable products, Gräfe¹ calculates the wear of the retort to amount to 0·4 lb. when vacuum distillation is employed, whilst for distillation at ordinary pressure a smaller allowance—about 0·3 lb.—will suffice.

The retorts discarded as no longer suitable for the distillation of tar and oil, can still be used for distilling the waste products, acid resins.

C. THE MESSEL DISTILLATION PROCESS.

Apparatus for and Method of Distillation.

The distillation tar or crude oil is freed from water as much as possible and is pumped into high-level tanks, in the usual manner, from whence it is drawn off into the stills, which are made in two parts and are large enough to hold a charge of 1600 to 1700 gal. Distillation is conducted in a partial vacuum and is facilitated by the action of stirrers. The thick residue is drawn off into retorts in which it is distilled to a cokey residue. These retorts alone need to be cooled down considerably for the purpose of entering them and removing the incrustated contents, the other stills being worked continuously. Tubular condensers, each provided with two receivers, are used. The partial vacuum is maintained by means of slide-valve air pumps, fitted with mercury gauges for measuring the vacuum produced. The stills and retorts are chiefly heated by burning the acid and alkali tar from the mixing plant.

The Distillation Products.

The distillates from the residue retorts are united with the tars and decomposed into a light and a heavy fraction, the former amounting to 16 per cent and the latter to 76 per cent. After chemical treatment, the first fraction is redistilled, and furnishes, on the one hand, naphtha and crude lamp oil, and on the other, gas oil. The heavy fraction represents paraffin mass, and after chemical treatment is redistilled. This process yields a small proportion of light oil, which is used direct as gas oil.

There is no separation of the heavy portion into soft and hard paraffin masses, the two being collected together and crystallized by cooling. The cooled mass is filtered in a press, and the press oil is collected, cooled down to -2° C. and filtered again. The last filtrate is either used direct for gas oil, or occasionally worked up into lubricating oil. The lamp oil is treated to bring the colour and smell to a high state of perfection; but in spite of its low density (0·800) has such a high viscosity and low capillarity when burned in lamps that it cannot nowadays compete with ordinary petroleum.

¹ Gräfe, "Die Braunkohlenteer-Industrie" ("Lignite-tar Industry"), p. 56.

D. THE DISTILLATION PROCESS IN THE SCOTTISH INDUSTRY.

Apparatus for and Method of Distillation.

At one time the Scottish shale tar, or crude oil, was distilled in retorts similar to those used in the Saxon-Thuringian industry, the other oils being distilled in large stills with a capacity of about 630 cub. ft.¹ In both cases the distillation was assisted by steam, and the several fractions were subjected to chemical treatment.

At the present time, however, the Henderson² continuous process of distillation is generally employed for the tar. The apparatus was patented in 1885.³ A still in the shape of a boiler with corrugated bottom, and holding about 10 tons, is connected with two similar stills arranged at the side and in turn connected by means of pipes with a row of six small coking stills of the form illustrated in Fig. 45. The upper part A of the coking still is of steel, and the lower part B of cast iron. The tar is distilled in the three large stills, the residue being distilled to dryness in the six small stills, of which two only are working at a time. The tar is passed through a preliminary heater—which is heated by the effluent vapours from the stills, and therefore also acts as a condenser—and fed into the middle still. Here the light fraction (naphtha) is distilled off. The heating of this still is regulated in such a manner that only the aforesaid light fraction is eliminated from the continuously fed tar, whilst the heavier fractions of the tar flow continuously along the rear wall of the still into the two lateral stills. These are more strongly heated and expel the second fraction (green oil) continuously. The residue from these second stills is led to the coking stills and distilled to dryness, the distillate being united to the green oil.

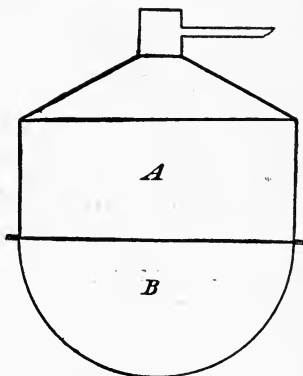

FIG. 45.—Small coking still.

The distillation process is continuous, commencing in the middle still—in which the tar feed pipe dips into the charge—and is continued in the two lateral stills, which are fed through a pipe opening only a short distance above the bottom of the middle still.

The coking stills require cleaning out after each charge, for which reason three pairs of these stills are provided, as mentioned above.

By carefully maintaining uniform heating temperatures, the pro-

¹See Scheithauer, "Die Fabrikation der Mineralöle" ("Manufacture of Mineral Oil"), p. 118.

²Steuart, "Economic Geology," 3, No. 7; "The Shale Oil Industry of Scotland," p. 584.

³"Chemical Technology," 2; "Lighting," pp. 221 *et seq.*

cess yields distillates of constant composition, and is very economical in comparison with the older distillation processes. The operation is assisted by steam.

Each still is provided with a separate condenser for the distilled vapours.

As a rule, the stills employed for the various kinds of oil are very similar to, or identical with, those used for the crude oil. One of these, patented by Henderson in 1883, is shown in Fig. 46. It consists of three horizontal stills, A, B, and C, about 33 ft. long and 8½ ft. wide. At the bottom of each still is a draw-off pipe *a*, the feed pipe *b* being arranged at the same end wall. Whereas, however, *a* is attached to the still wall by means of a flange, the pipe *b* passes through this wall and right through to near the other end of the still, so that the oil enters and leaves the still at widely separated points. The oil to be distilled is fed into A, where the lightest fraction is distilled off; after which it flows through *b* into B, where the second fraction is

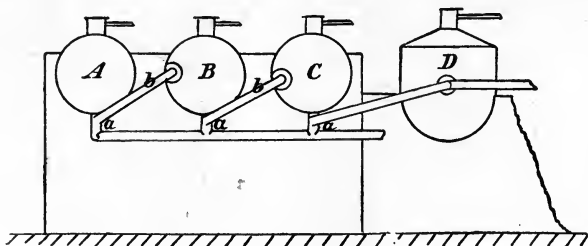

FIG. 46.—Horizontal stills with retort.

expelled, the third fraction being driven off in C, and the residue distilled to dryness in the retort D. The process is therefore the same continuous distillation as already described in the case of tar. The oil flowing continuously into A is warmed by the escaping distillation vapours in the condenser, which, in the case of each still, consists of a pipe about 66 yd. long and 4 in. in diameter.

Young and Beilby¹ have devised a somewhat different apparatus for continuous distillation. A large horizontal still is divided by cross partitions into a number of intercommunicating compartments traversed by the oil. The heating of the several compartments being different, only a certain fraction is distilled off in each and collected separately in a condensing device. In the first compartment, where the fresh oil is admitted, the lightest oil is vaporized, the remaining portions flowing into the second compartment where the second fraction is distilled off, and so forth.

This form of apparatus is used for the lighter oils, whereas the heavier oils, e.g. blue oil, are distilled in retorts such as shown in Fig. 47.

¹ "Chemical Technology," 2 ("Lighting"), p. 227.

All the distillations are effected by the aid of steam ; and about 20 per cent of condensed water is obtained in the case of the heavy oils.

Distillation Plant.

As already stated, the distillation plant is of the simplest character. The battery of stills, containing a large number of apparatus, has neither walls nor roof ; and even the boiler-house (if it may be so called) consists merely of the brick-mounted boilers without any other protection. Though this system may be justified by the mildness of the climate, it seems—in view of the heavy rainfall in Scotland—to rest more on tradition than convenience.

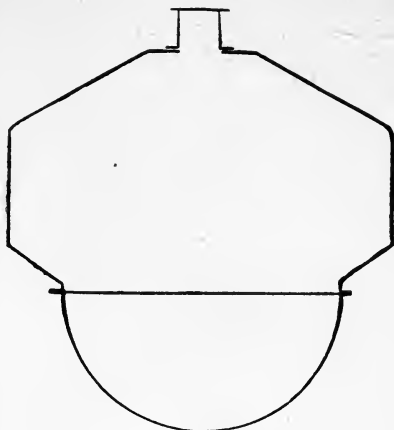

FIG. 47.—Retort for heavy oils.

The Distillation Products.

Diagram III illustrates the course of distillation as practised at Broxburn, one of the largest Scottish works. The shale tar is decomposed into two main fractions, naphtha and green oil.

The naphtha, on distillation after chemical treatment, furnishes two light oils, of specific gravity 0·730 and 0·740, the residue being united with the green oil.

The green oil is chemically treated, and is then separated by distillation into three fractions: light oil, heavy burning oil, and hard-paraffin mass. After chemical treatment, the light oil is distilled and yields naphtha, lamp oils of specific gravity, 0·785, 0·800 and 0·810, and a soft-paraffin mass. The heavy burning oil, forming the second fraction from the green oil, is chemically treated and distilled into burning oil (united with the light oil previous to distillation), soft-paraffin mass and hard-paraffin mass.

The soft-paraffin mass is united with that from the light oil, and on further treatment yields soft-paraffin scale and gas oil (specific gravity, 0·850).

The hard-paraffin mass is also sent to the paraffin works for treatment, under which it furnishes hard-paraffin scale (which will be dealt with later) and blue oil. This latter is chemically treated and distilled, yielding two lubricating-oil fractions. Both are sent to the paraffin department and furnish soft-paraffin scale and lubricating oils of specific gravity 0·865 and 0·885.

In other works the oils, which are classified according to colour as

well as the purpose for which they are intended (lamp oil, gas oil, lubricating oil), are partly known by different names. The scheme of distillation (Diagram IV) is also simpler.

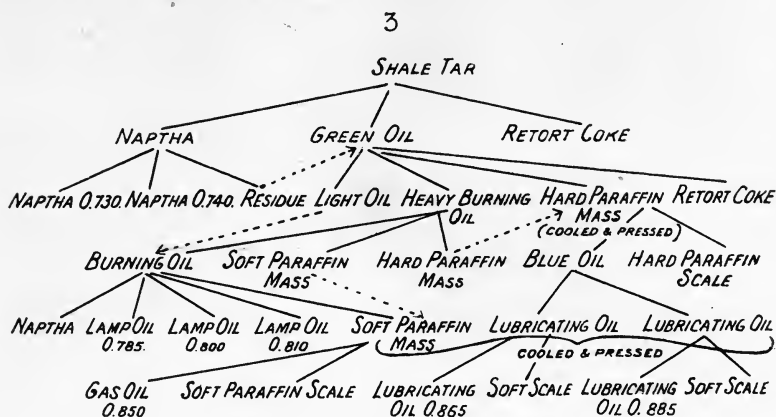

DIAGRAM III.—Distillation of shale tar (crude oil) as practised at Broxburn.

Retort coke and retort gas are other products of the distillation process. The coke which represents about 3 per cent of the tar, is a valuable article, and is used for making black pigments and for electrical purposes.

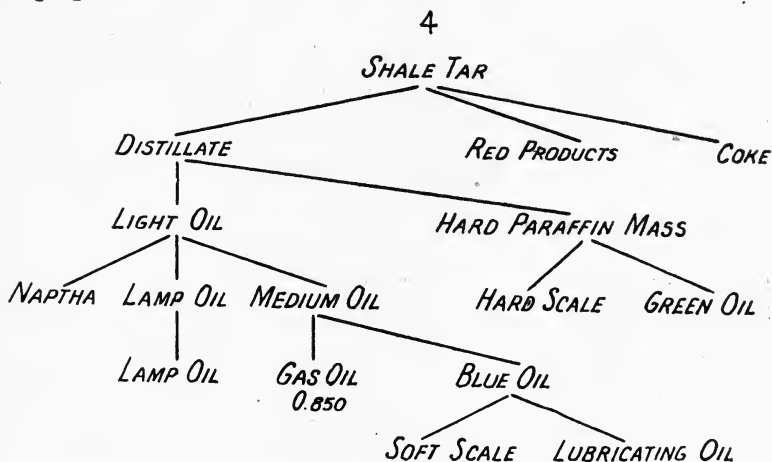

DIAGRAM IV.—Distillation of shale tar (crude oil) by classification of the various oils.

The retort gas is used for lighting¹ and heating, and, according to

¹The small town of Broxburn is lighted with retort gas from the Broxburn Oil Co.'s works.

Beilby,¹ has the following composition :—

Heavy hydrocarbons	14.5 per cent.
Methane and homologues	59.0 "
Ethane	26.5 "
Hydrogen	traces.

No carbon dioxide, carbon monoxide, or oxygen has been detected.

In the condensing apparatus, the retort gas deposits a light benzine, which, during the last few years, has found employment as motor spirit.

¹ Humphrys, "The Chemistry of Illuminating Gas," p. 172.

CHAPTER VI.

I. CHEMICAL TREATMENT OF THE TAR AND ITS DISTILLATES.

THE chemical treatment of the tar and its distillates is termed refining, and is performed in agitators.

A. THE REFINING PROCESS.

Distillation separates the several fractions of the tar, and effects their purification, with an improvement of the colour and smell, retort coke and retort gas being produced. A further purification of the distillates is effected by chemical treatment with sulphuric acid and caustic soda, which remove substances which either have an unfavourable influence on the colour and smell or lessen the suitability of the oils for use. These substances mainly consist of basic and acid constituents and of dark-coloured heavy hydrocarbons.

The sulphuric acid for the preliminary treatment is of specific gravity 1.53 (50° B.), a stronger acid (specific gravity 1.84 or 66° B.) being used for the treatment proper. Concentrated or fuming acid is not used, experiments having demonstrated its unsuitability for treating heavy tar oils, though it can be advantageously employed in refining petroleum. The acid is obtained in tank cars—rarely in glass carboys.

The caustic soda has the specific gravity 1.36 to 1.38 (38° to 40° B.), and is prepared in the works by dissolving drum soda in water.

Other chemical reagents, such as hydrochloric acid and nitric acid,¹ and other methods of refining, have been tried from time to time and recommended in the literature, but have not found practical application.²

The preliminary acidification with dilute sulphuric acid eliminates any residual traces of water, and a portion of the basic constituents, such as pyridin bases, which are soluble in dilute acid. The stronger acid (66° B.) then used extracts from the oils all the basic substances and a portion of the unsaturated hydrocarbons which give the oil a dark colour by oxidation and resinification. The treatment also produces oxidation, revealed by the strong smell of sulphur dioxide, whilst polymerisation and substitution can also be observed. The chemical

¹ Austrian Patent No. 10,253, 1901.

² W. Scheithauer, "Die Fabrikation der Mineralöle" ("Manufacture of Mineral Oils"), pp. 139-40.

processes which go on during the sulphuric acid treatment are difficult to follow and have not yet been fully elucidated.¹ In order to prevent excessive decomposition, the acid is allowed to act in the cold, unless other conditions are rendered necessary by the products (paraffin mass or tar) under treatment. The acid resins, resulting from the sulphuric acid treatment, settle down to the bottom of the agitator and are removed, which done, the oil is washed with water, to remove the last traces of free acid, and is treated with caustic soda. The tar itself is never mixed with alkali, but only its distillates. The actual alkali treatment is preceded by a preliminary alkalification, a small quantity of lye or regenerated lye being added to neutralize the traces of acid and absorb the particles of water, this lye also, of course, dissolving acid bodies present. The subsequent treatment with larger quantities of caustic soda extracts the acid bodies: homologues of phenol, etc., known by the generic name of creosote,² which impart a disagreeable smell to the oil and, like the unsaturated hydrocarbons cause the colour to darken afterwards. According to Gräfe,³ the solvent capacity of these substances towards paraffin also adversely affects the yield of that constituent. The product of the reaction is known as soda tar. This treatment is usually succeeded by washing with water, to remove the traces of alkali.

The two reagents are now used in the order given above, whereas it was formerly the practice to employ the alkali first, and then the acid. The consequences of the two chemical actions were regarded as immaterial, which is erroneous. On the one hand these tar oils contain substances which are soluble both in sulphuric acid and caustic soda, and it is advisable to allow the cheaper reagent, the sulphuric acid, to act on them. On the other hand the product of the reaction with soda is more easily washed out with water, and is also less soluble in the oils themselves than are the products of the acid reaction, so that secondary decompositions are more easily avoided in the subsequent distillation of the treated oils.

B. THE REFINING PROCESS IN THE SAXON-THURINGIAN INDUSTRY.

The Agitator.

The agitators or mixers generally used consist of cylindrical vessels with conical bottom, varying in dimensions according to the amount of oil to be treated, and holding from 1100 to 4400 gal. Vessels of different shapes⁴ were formerly used, mostly of wood; but these have now been entirely superseded by iron vessels, lined with sheet lead about one-fifth of an inch thick. This lining is necessary to protect the walls of the vessel from the action of the acid, especially the dilute

¹ Compare Palui, "Chemiker Zeitung," 1900, 969.

² The name relates to its disinfectant action, and is derived from creas (flesh) and sozo (I preserve).

³ Gräfe, "Die Braunkohlenteer-Industrie" ("Lignite-tar Industry"), p. 59.

⁴ Scheithauer, "Die Fabrikation der Mineralöle," p. 131.

form. The purest lead should be used, this being least corroded by the sulphuric acid.¹

The agitator is usually covered by a lid, provided with an observation flap; and in many works the vessel is fitted with a pipe for conveying the liberated gases into the outer air without allowing them to escape into the room.

In the early days of the industry, the oil and chemicals were mixed together by means of wooden paddles worked by hand; but these were afterwards replaced by mechanically operated stirrers;² and for some years past, the mixing has been effected by blowing air into the oil and chemicals in the agitator. The duration of the process being short, the chemical action of the air may be disregarded.

Fig. 48 represents an agitator A. The charge of oil is introduced through the pipe *a*, and the acid, alkali, and water separately through the pipes *b*, *c*, *d* respectively. The air is blown in through a leaden pipe *e* which extends to the bottom of the vessel. The products of reaction and the washing water are drawn off through the tap G, whilst the treated oil is removed through the tap F.

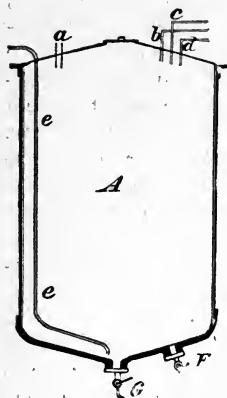

FIG. 48.—The agitator.

the aid of pipes. A suitable arrangement for this purpose will be described under the heading of "The Refinery".

If, as already mentioned, the material under treatment has to be warmed previous to chemical treatment, this is effected either by means of an internal lead coil or by a steam jacket.

The Refining Process.

Formerly the chemicals were transported by hand (buckets and hoists), but at the present time they are introduced mechanically by

The Chemical Treatment of the Tar.

In some works the lignite tar is still subjected to treatment with sulphuric acid previous to distillation. This method was first introduced by B. Hübner,³ and has many advantages over that in which the crude tar is distilled. In distillation, tar that has been treated with sulphuric acid disengages less noxious gases, the retort coke is reduced by about 50 per cent, and the loss of gas is considerably smaller than when the crude tar is distilled; whilst at the same time the retorts suffer less injury, because less heat is needed for distillation. The creosote content of the distillates is smaller, and with certain tars

¹ Lunge and Schmidt, "Zeitschr. f. angew. Chemie," 1892, pp. 642 and 664.

² Scheithauer, l.c. p. 131 *et seq.*

³ "Berichte d. Deutsch. Chem. Ges.," 1868, p. 133.

an appreciably higher yield of paraffin is obtained. Some practical authorities, however, hold the opposite view, and believe more paraffin can be recovered when the tar is distilled crude. This divergence of opinion is probably due to the fact that only tars free from bitumen should be treated with sulphuric acid. If, however, the tar contain bitumen, this substance dissolves to a large extent in the acid, so that some of the paraffin formers are destroyed, the loss of paraffin being thereby explained. It is not difficult to regulate the dry distillation in such a manner that the tar is obtained free from bitumen without suffering any considerable decomposition.

If the tar be distilled crude, the paraffin masses must be refined—an operation entailing great care—and, in particular, a thorough final washing is essential to prevent corrosion of the filter and press cloths. The crystallization of the paraffin is better when the mass is allowed to crystallize without refining after distillation.

The tar is freed from water by treating it with $\frac{1}{4}$ per cent of sulphuric acid of 50° B. strength, or 1 to 2 per cent of recovered acid,¹ and is then treated with 3 to 4 per cent of acid of 66° B. strength for a quarter to half an hour. The tar is next left alone for three to four hours, to allow the reaction products to settle down, whereupon the acid resin is drawn off. Hot water is now sprayed over the surface, and milk of lime is mixed in for about a quarter of an hour, to neutralize the residual acid, the tar being ready for distillation after the lime-water and deposited sediment have been drawn off. This washing process requires great skill and care, owing to the tendency to form emulsions which result in loss of tar.

From the above it follows that the practice of treating the tar with sulphuric acid previous to distillation is now still justifiable; though where distillation in a partial vacuum is practised there may be important reasons for giving preference to the other process.

Refining the Tar Products.

The proportion of sulphuric acid used in the chemical treatment of the tar products depends on the character of the raw material and varies in different works. The point to be kept in mind is to obtain a marketable product in respect of colour and smell. As a rule 2 to 5 per cent is taken, or 6 per cent at the most. If more than 3 per cent be employed, the main acid treatment is divided into two separate stages. As in the case of oil refining, the products of the reaction are left for some time to settle down. After drawing off the acid resins, two successive washings are given with water, the mixture in each case being agitated for a quarter to half an hour and left to settle about two hours. In order to accelerate and complete the neutralization of the acid, the water is sometimes given a small addition of sodium carbonate, caustic soda, caustic baryta, or, as in treating the tar, caustic lime.

¹Recovered acid is that recovered in the works from the spent acid from previous operations.

The acid process is followed by treatment with caustic soda. After a preliminary treatment with about $\frac{1}{2}$ per cent of caustic soda lye, the products of this reaction are drawn off at the end of about an hour. Then follows the main treatment which is really one of "leaching," since the whole of the creosote, for example, must be eliminated from the oil. The amount of alkali used must be calculated so as to secure this result. The accuracy of the treatment is easily checked, by experimenting with a small quantity of material in a test tube, and the requisite additional amount of alkali determined. The quantity varies between 4 and 8 per cent of caustic soda in different works. As a rule 3 to 4 per cent is used at a time and mixed for half an hour, the whole being then left to settle down for three to four hours, and the oil afterwards distilled either direct or (as is done in some works) after washing out the surplus alkali with water.

The loss resulting from the chemical treatment (waste in refining) varies, of course, in different works. It depends on the character of the oil, and particularly on the percentage of creosote.

Assuming that the tar has been acidified, the following tar products of those mentioned in Diagram I are subjected to chemical treatment. The A-filter oil (2 to 4 per cent of sulphuric acid, 66° B.) the crude oil (3 to 4 per cent of acid), the crude solar oil (1 to 2 per cent of acid), and if necessary the lignite tar benzine (1 to 2 per cent of acid). In all cases the agitation lasts a quarter to half an hour, the time depending on the quantity of oil in the agitator. All the oils are freed from creosote before being distilled.

When the tar is distilled crude, then, according to Diagram II, the following products will be chemically refined: the light crude oil (with 3 to 6 per cent of sulphuric acid, 66° B.), the hard-paraffin mass (3 to 6 per cent), the light crude photogen (4 to 5 per cent) and the benzine (2 to 3 per cent of acid). In this case also the creosote is completely extracted from the products in question by treatment with caustic soda lye of 38° B. strength.

Treating the Oils before Delivery.

Of the commercial oils, only the paler kinds are treated chemically before being sent out; and this is done in only a few works.

Solar oil is treated with small quantities of sulphuric acid and then washed with dilute caustic soda, or sodium carbonate solution. In other works it is treated for about two hours with a mixture of $\frac{1}{2}$ per cent of caustic soda and $\frac{1}{4}$ per cent of spirit, to improve the smell.

The light vaseline oils, cleaning oil, and yellow oil, as also the gas oil are treated, if necessary, with 1 to 3 per cent of sulphuric acid and then with caustic soda lye, also with dilute sodium carbonate or sodium silicate¹ solution, the last named being found very useful for pale yellow oils.

In contrast to the practice adopted in the case of intermediate pro-

¹ Recommended by J. Zahler, "Chem. Ztg.," 1897, pp. 853 and 899.

ducts, the refining of the finished or commercial products is usually carried on in two separate vessels for the two reagents; the oil being pumped into another agitator after being washed at the end of the acid treatment.

Sun-bleaching, in order to improve the colour of commercial oils, is not practised on a manufacturing scale, being too cumbersome and tedious; but it is always efficacious.

In order to obtain good, marketable products, the chemical refining of lignite tar and its distillates entails an average consumption of 6 to 7 per cent of sulphuric acid and 0.8 to 1.3 per cent of caustic soda, calculated on the weight of the raw material. The amounts will not be smaller except in the case of tars of such good quality as is now rarely produced.

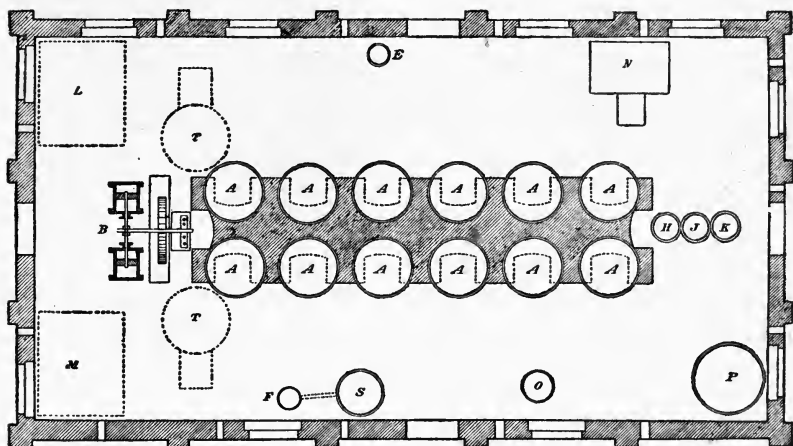

FIG. 49.—Plan of agitator house.

If, as occasionally happens, it is desired to destroy the bluish-green fluorescence of the vaseline oils before admitting them into commerce, they are mixed for some time with 0.25 to 0.5 per cent of nitro-naphthalene. On being left at rest, the nitro-naphthalene sinks to the bottom and can easily be separated from the oil.

It should also be mentioned that pyridin bases were formerly recovered from the first tar distillate (crude oil) by treatment with sulphuric acid of 30° B. strength. The acid resins were separated from the sulphuric solution by settling and filtration through retort coke, and the solution was then decomposed with dilute caustic soda, the bases being dried and fractionated by distillation. They were sold for purifying anthracene and denaturing spirit. For some years, however, their preparation has been abandoned since they were unable to comply with the stringent requirements—in respect of boiling-point and solubility in water—to be fulfilled by bases employed for denaturing.

The Agitator House.

Figs. 49 and 50 illustrate a plan and longitudinal section of an agitator house. A, A are the agitators, mounted on a brick foundation and shaped like the one shown in Fig. 48. B is the air pump which forces air in through the pipe *e*. C is the sulphuric acid tank, from which it is drawn in suitable quantity to the agitators through the pipe *b*, whilst D represented the caustic soda tank connected with the agitators by the pipe *c*. The acid is forced into C from a pressure tank E by compressed air, and the caustic soda solution is forced by similar means from the pressure tank F, after being prepared in the vessel S. The products of the reactions are drawn off through G and delivered through pipes *g*, *h* to tanks H, J, K, where they are collected for further treatment. A stage R, R, resting on pillars, runs alongside the agitators. L, M, N, O, P are oil-storage tanks, and T, T are pressure tanks.

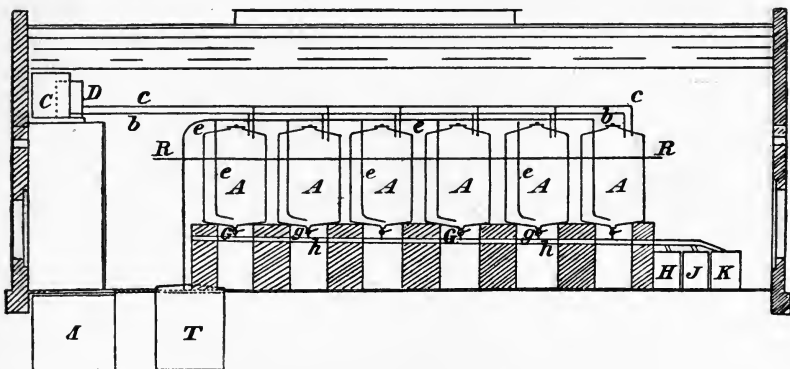

FIG. 50.—Longitudinal section of agitator house.

Most agitator houses are arranged on these lines, their dimensions and those of the vessels used varying according to the quantity of oils¹ to be treated, and therefore the amount of tar at disposal.

Whilst corrugated sheet iron has advantageously replaced mill-board as a roofing material for industrial buildings, it cannot be used for agitator houses as the metal would be rapidly corroded by the sulphurous acid given off and condensed.

C. REFINING PROCESS IN THE MESSEL INDUSTRY.

The distillation tar (crude oil) is not chemically refined, but the first fraction of distillate is mixed successively with 2 per cent of sulphuric acid and 3 per cent of caustic soda. The crude mass is treated in the same way. The deposited acid resins are washed with water and burned to heat the stills. The agitators for the acid treatment are lined with lead.

¹ Krey, "Journ. f. Gasbel.," 1890, p. 408.

D. REFINING PROCESS IN THE SCOTTISH INDUSTRY.

Methods.

Sulphuric acid (66° B.) and caustic soda are also used for the chemical refining of the oils in the Scottish industry; and with few exceptions—in contrast to former practice—these reagents are used in the order given. The sulphuric acid is required to be of high purity and free from arsenic and selenium. The large works, like those at Broxburn, produce their own sulphuric acid in a special department.

Whereas in the Saxon-Thuringian industry it is the general rule to carry out all the refining processes in the same vessel, a separate agitator is used for each process in the Scottish works. Two wrought-iron vessels, mounted one above the other, are employed, the sulphuric acid treatment being performed in the upper one and the caustic soda treatment in the lower one.

At one time the agitation was affected solely by means of stirring mechanism built into the agitators; but now most works—like those in Saxon Thuringia—use compressed-air agitators. Stirrers are only used for treating the light oils, such as naphtha, in order to avoid the losses that would arise from blowing-in air.

The tar is never chemically refined, being itself produced by steam distillation and therefore containing large quantities of undecomposed bitumen, which has to be transformed into hydrocarbons by distillation, and would dissolve in the sulphuric acid.

Chemical Treatment of the Tar Products.

The tar distillate ("green oil" of Diagram I) is mixed with 3 to 4 per cent of sulphuric acid for a quarter to half an hour, the reaction product being drawn off at the end of three to four hours. In some works, as in the Saxon-Thuringian industry, this operation is preceded by a treatment with sulphuric acid of 34° B. strength, or else with acid previously used for refining oil. After the sulphuric acid process the oil is run into the lower agitator, where the acid is neutralized with dilute caustic soda of 38° B. strength (about $\frac{1}{2}$ per cent). When the product of this reaction has settled down it is drawn off, and the oil is then mixed with 2 to 3 per cent of caustic soda lye (38° B.) for half an hour. The mixture is left as long as possible—three to six hours or occasionally over night—and the soda tar is removed.

The light oil furnished by distilling the green oil, is mixed for a quarter to half an hour with $2\frac{1}{2}$ to $3\frac{1}{2}$ per cent of sulphuric acid (66° B.) after a preliminary acidification. The acid resins are removed at the end of two hours, the acid being neutralized with dilute caustic soda in another agitator, and the oil treated with $2\frac{1}{2}$ to $3\frac{1}{2}$ per cent of caustic soda (38° B.) for a quarter to half an hour. After leaving to settle for two to three hours, the soda tar is drawn off.

In addition to the above, the following oils mentioned in Diagram I are treated with varying quantities of sulphuric acid and freed from

creosote by treatment with caustic soda : naphtha, heavy burning oil, burning oil, and blue oil.

In some works chemical treatment is applied to other oils and also to the paraffin mass ("heavy oil").

Most works treat the oils before sending them out, the lamp oils and lubricating oils in particular. The oil is mixed for a short time with a small percentage of sulphuric acid, and washed with dilute caustic soda (3° to 5° B.) or sodium carbonate solution after the removal of the acid resins.

II. THE UTILIZATION OF THE REFINERY WASTE.

USES AND TREATMENT.

The acid resins are like coal-tar in appearance and have a penetrating sulphurous smell. At some works in Saxon Thuringia instead of treating the acid resins and soda tar separately, the two products are mixed, whereupon the creosote and resins are thrown down and a solution of sodium sulphate is formed.

It is preferable to decompose the acid resins separately by boiling them with steam admitted into the bottom of the vessel, the resins separating out on the surface of an impure dilute sulphuric acid. This waste acid or recovered acid, has the density 30° to 40° B., is of a brown colour and, after being completely freed from resins, is used either in the preliminary acid treatment in refining or for decomposing the soda tar. It also finds employment in manure works¹ and may—as was formerly the case in many works—be used in the preparation of salts of iron and zinc, which metals it dissolves. When employed for decomposing the soda tar, it furnishes Glauber salt, which is purified by recrystallization, in some works, and put on the market.

The resins are distilled in retorts similar in shape and mounting to those already described. The vacuum process is not employed, but generally superheated steam is blown in at the bottom of the retort. The distillation furnishes an oil, creosote oil of specific gravity 0.940 to 0.980 and soluble to the extent of 50 to 70 per cent in caustic soda. It smells strongly of sulphuretted hydrogen. As a rule the distillation is not continued to dryness, a tarry residue ("goudron") being left; or asphaltum, if more oil be expelled. In some works this residue is expelled from the retorts by compressed air, and in others is drawn off or ladled out by suitable means.

In many of the works in Saxon Thuringia, the resins are used for heating the stills and boilers as in Scotland and at Messel, for which purpose they are burned in steam atomizing burners (Forsunka). The heating value is about 8000 cal. The resulting sulphurous acid does not seem to have any corrosive effect on the iron.

The soda tar is a thick black liquid. It is used for impregnating colliery timbers after the excess of caustic soda present has been neutralized preferably by adding crude creosote in excess.

¹ See "Zeitschr. f. angew. Chemie," 1900, p. 1033.

One method of utilizing this soda tar is by using it in a diluted state (4° to 5° B.) in place of caustic soda for purifying boiler-feed water. A neutral oil which collects on the surface of the mixture during dilution must be removed. One hundred gallons of this aqueous liquor are equivalent in effect to 22 to 25 lb. of caustic soda. The steam from the boiler water purified in this way smells slightly of creosote and must not be used for chemical purposes.

Another method for utilizing this soda tar forms the subject of Ger. Pat. 166,411, by the Warschen-Weissenfelser-Braunkohlen A. G., Halle. The material, either in its crude state or after dilution with water (1 : 5) is used for dissociating vegetable substances of all kinds, such as straw and wood for paper-making, the resulting cellulose being very flexible whilst exceedingly strong and tough. Whether this process will make any great headway in the paper industry remains to be seen.

The soda tar is decomposed by acids, crude creosote being deposited. Either recovered acid or, preferably, carbonic acid is used for this purpose, the last named being produced in the works by passing air over gas coke or retort coke. Flue gases or retort gases may also be used, Höland employing the gases from the retort stills, which gases are thereby freed from carbon dioxide and sulphuretted hydrogen.

In the Scottish industry the acid resins are washed with hot water, and the dilute acid thus recovered is used for the preparation of sulphate of ammonia in the shale-distilling process. The precipitated resins are mixed with the soda tar and are carefully separated from the resulting sodium sulphate. As already mentioned, the purified resins and creosote are burned in the Forsunka burners, for the purpose of heating the stills and burners.

Recovering the Chemicals.

In spite of numerous attempts, no one has yet succeeded in recovering the spent chemicals from the tar-oil refining processes in such condition that they are fit for use over again. On this account, the waste products of the reactions are, as already mentioned, worked up into by-products in order to reduce the outlay on chemicals.

A large number of patents¹ have been taken out for processes claiming either to recover the sulphuric acid from the acid resins or to work up the waste acid to hydrochloric acid and nitric acid. None of them, however, fulfils the requirements of practice, the recovered acid being either too impure for technical use, or else the process is too costly to work at a profit. For these reasons it is unnecessary to go into these processes in detail.

The best way is to utilize the acid resins in the manner already described, since, according to the experiments already performed

¹ See Scheithauer, "Die Fabrikation der Mineralöle," pp. 149 *et seq.*; Heinrich, "Zeitschr. f. angew. Chemie," 1898, p. 525; Wischin, *ibid.* 1900, p. 507; G. Stolzenwald's Ger. Pat. 212,000; "Petroleum," Vol. IV, p. 1238; "Chem.-Ztg. Rep.," 1910, 13.

there seems no possibility of ever recovering pure sulphuric acid in a profitable manner from the acid resins in question.

Caustic soda being more expensive than sulphuric acid, it becomes correspondingly more important to recover the spent alkali or to manufacture a by-product of suitable value from the soda tar.

The spent alkali from refining the light oils, being capable of taking up more creosote, can be used in the preliminary alkali treatment.

The decomposition of the spent alkali has already been dealt with. If carbonic acid be used for this purpose, the resulting sodium carbonate can be causticized, as is done in some works. The caustic soda recovered in this way is of a brown colour due to organic admixtures, has the specific gravity 1.30 (30° B.) and can be advantageously used in the preliminary stage of refining.

The spent alkali, after being separated from accompanying oil by dilution with water, may also be distilled in the ordinary retorts, sawdust or tan bark being added to prevent frothing over. As a rule distillation is carried to dryness, creosote oil being obtained as distillate. The residue is calcined in shaft furnaces to burn off the carbon, and the crude sodium carbonate may be purified by redissolving and recrystallization. This was practised by Krey, who placed ground soda crystals on the market for a number of years. On the other hand the crude salt can be lixiviated and then causticized with quick lime in the ordinary way.

CHAPTER VII.

THE MANUFACTURE OF PARAFFIN.

PARAFFIN, the most valuable constituent of the distillation tars, can be recovered from same in a crystalline form, the separation from the adherent oils being easier, and therefore the paraffin purer in proportion as the crystals are more definite. In order to obtain this result, certain rules must be followed. Either the tars or oils containing paraffin must be distilled without the aid of steam, or else the amount of steam admitted must be restricted as far as possible. Otherwise the paraffin crystals will be small, difficult to purify, and will give a larger proportion of loss than when the crystals are large and well defined. For the same reason the vacuum must not be too high in the case of vacuum distillation. The paraffin masses must be left at rest for complete crystallization, since any disturbance of the crystallizing process retards the deposition of the paraffin and the formation of crystals.

As may be gathered from the diagrams already given, the paraffin is gradually extracted from the tar. Thus, in the Saxon-Thuringian industry, hard paraffin alone is obtained from the first paraffin-bearing distillate, the A-paraffin mass, the soft paraffin being obtained subsequently from the soft-paraffin masses furnished by the different following distillations. Hence the hard-paraffin masses are allowed to crystallize out at a higher temperature than the soft-paraffin masses. This method of procedure furnishes a good, hard paraffin; and the soft paraffins also are obtained in purer condition, being recrystallized by the distillations needed for concentrating the paraffin solutions, and therefore separating out in the desired form of large flakes on cooling.

Numerous experiments have been made during a long period, to try and obtain paraffin direct from distillation tars without distillation. Rolle¹ patented a process with this object; and Anschütz² carried out exhaustive experiments in the same direction at the Köpsen works. In both cases the paraffin scale obtained was dark in colour and very difficult to refine, so that this method had to be abandoned. Pauli³ and Singer⁴ took out patents for a similar method based on the well-

¹ Schliephacke, "Zeitschr. f. die Paraffin-, Mineralöl- und Braunkohlenteer-Industrie," 1876, p. 34.

² Grotowsky, "Jahresber. d. Technikervereins d. sächs.-thür. Mineralölin-dustrie," 1889.

³ Ger. Pat., 123,101.

⁴ Ger. Pat., 140,546.

known insolubility of paraffin in alcohol, the resins, creosote, and oils contained in the tar being soluble in that liquid. No experienced practical man, however, would dream of even trying this method on a manufacturing scale.

Greater probability of success is possessed by methods aiming at the isolation of the paraffin from the paraffin masses—in which it is present in a purer condition than in the tar—by other means than cooling and crystallization. Although all endeavours of this kind have proved unsuccessful hitherto, it is not impossible that a method may ultimately be found that will enable the solid hydrocarbons to be separated, on a technical scale, from the liquid members in the joint solution. Wagemann¹ proposed to throw down the paraffin from solution in oil by means of certain gases. Krey and his pupils demonstrated, by careful experiments, the impracticability of separating paraffin from oils by dialysis.

Gases have been separated from mixtures by the aid of centrifugal force,² and though no successful results have yet been obtained in the case of liquids, there is, nevertheless, a possibility of being able, by this means, to separate a mixture of bodies which are in the same condition of aggregation, but differing in density and other properties.

We will now proceed to describe the methods in current use for recovering paraffin from distillation tars.

A. THE MANUFACTURE OF PARAFFIN IN THE SAXON-THURINGIAN INDUSTRY.

The Crystallization Process.

Vessels of different dimensions and differently arranged crystallizing plants are used for the crystallization of the paraffin masses in the various works. The larger the tank the longer the time required for cooling down the mass in order to give complete separation of the paraffin crystals.

The A- (hard-) paraffin mass is generally placed to crystallize in small vessels holding about $6\frac{1}{2}$ to 11 gal. In some works these vessels taper towards the bottom, whilst in others they are prismatic; and some works again use larger vessels holding up to 22 gal. Water is chiefly used for cooling the smaller vessels, but those of larger size are exclusively cooled by air. As a rule, the small vessels are placed in compartments in a cooling cellar where they are surrounded by well-water. If the works are connected with a mine, pit water is used; otherwise the requisite cooling water is raised by a pumping plant, which also supplies the condensers of the distillation plant. The large vessels are set up in cool, well-ventilated rooms.

After distillation or chemical refining, the paraffin mass, at a temperature of 50° to 70° C., is delivered through pipes to the crystallizing vessels, into which it is fed by suitable devices which ensure rapid

¹ Dingler's "Polytechn. Journ.," 139, p. 303.

² "Journ. f. Gasbel.," 1904, p. 943.

working and protect the operatives from being inconvenienced by the vapours. Air cooling is also applied in the first stage of cooling the small vessels, in order to favour the development of the crystals by a gradual reduction in the temperature. The next stage is to admit to the compartment water that has already been used for cooling in other compartments and has therefore become warmer, this in turn being replaced by cold water. In the large, air-cooled vessels, where the cooling proceeds slowly, the position of the crystals is complete in ten to fifteen days, and the mass is "ripe" for further treatment. In the small vessels, the A-paraffin mass takes only four to six days to crystallize out. The above figures vary, within narrow limits, according to the time of year, being rather less in winter and more in summer. It is bad policy to cool the hard-paraffin mass too far, because at this stage the hard-paraffin scale alone is desired, the soft scale being left uncrystallized. As a rule the mass is worked at a temperature of 15° to 18° C.

The soft-paraffin masses are either crystallized in large vessels, holding 550 to 1100 gal., by the natural cold of the winter season, or else are cooled down in the same small vessels as used for the hard-paraffin mass, by the aid of refrigerating machinery.

In the former case, the soft-paraffin masses are accumulated in the crystallization tanks during the warmer months of the year; during the colder season a gradual crystallization of the paraffin scale takes place; and in the winter the mass is subjected to further treatment. The oil obtained in this way is regarded as technically free from paraffin, and indeed contains such a small proportion of paraffin—which moreover is of the consistence of ointment—that the recovery of the latter would be unprofitable. The conditions essential to successful working are: sufficient storage accommodation for the paraffin masses, and the provision of crystallization sheds that are fully exposed to the winter cold in all parts. The crystallization tanks must be large enough to hold quantities equal to about one-third of the total amount of tar treated during the year; and the buildings in which these tanks are housed must be of slight construction with lowered walls so that the cold wind can be admitted and warm air excluded, according to requirements.

When refrigerating machinery is used, the cooling liquid generally consists of brine reduced to a low temperature, the soft-paraffin masses being treated continuously, as soon as produced.

Ammonia absorption machines were formerly employed for the production of artificial cold, but the ammonia compression machine is now generally used as being of higher efficiency, and enabling the paraffin masses to be delivered to the filter press at temperatures of -10° C. and under. The possibility of producing much lower temperatures than could previously be attained has simplified matters considerably, since on the one hand far more dilute solutions of paraffin in oil can be crystallized, and on the other the resulting oil is so completely freed from paraffin that, except in the hot summer months,

it can be sent out at once. These two circumstances have also shortened the distillation processes. In some works, the artificial refrigeration system has enabled the winter crystallization process to be entirely dispensed with for some years past.

In the ordinary process in small vessels, the soft mass is cooled with water for several days and then reduced to crystallization temperature by means of very cold brine.

In some works the process is carried on with vessels of a different character. Wernecke (Ger. Pat. 92,241) allows the paraffin mass to solidify in cooling cells built into a cooling tank, the cooling agent consisting of brine cooled in a refrigerating machine. When the mass has set firm, it is ejected from the cells by pneumatic pressure into a conveyor device which transports the paraffin cakes for further treatment in the filter press as usual. The cost of repairs and the labour bill will determine the utility of this system.

It is impossible to decide generally whether the winter crystallization or refrigerating machine method is the best for treating soft-paraffin masses, so much depending on a number of factors. Points to be considered are: the quantity of tar to be treated, the extent of the existing plant for winter crystallization, and the destination of the finished soft-paraffin scale. In the case of larger works in which the bulk of the soft paraffin is worked up, on the premises, into composite candles, the refrigerating-machine method is undoubtedly indicated. Works of medium size, treating about 5000 to 6000 tons of tar per annum, equipped with an extensive plant for winter crystallization and obliged to turn out the finished soft paraffin in good condition for sale, are able to work satisfactorily with the winter crystallization method.

For reasons previously given it is an erroneous practice to use the refrigerating plant for hard-paraffin masses, by adding ice to the cooling water in order to obtain a very low temperature.

The Pressing Process.

The work is divided into three stages, viz. pressing in the filter press, in the vertical hydraulic press, and in the horizontal hydraulic press.

The cooled and crystallized A-paraffin mass is ejected or removed from the crystallization vessels by suitable means, and fed to the filter press.

In the case of the soft-paraffin masses, when the winter crystallization method is practised, the bulk of the oil from some of these masses is left in the bottom of the crystallization vessels, and a portion of the paraffin is thus recovered in a crude form without needing to be filtered. Other masses of this class are more difficult to treat, the mass being pumped or ladled out of the vessels and conveyed in tubs on a rail or overhead runway.

The paraffin masses are first crushed in a mechanical crusher (Fig. 51), the mass tipped into the hopper A being crushed by the rotary arms B and dropped into the collector C, from which receptacle the

pulpy mass is drawn by a pump and delivered to the filter press, where the crystals of paraffin are separated from the oil.

At the present time, filter presses¹ alone are used for this operation, though formerly centrifugal separators, like those in the sugar industry, or aspirators, were employed. Centrifuges are only suitable for masses in which the crystals are large; and aspirators cannot compete with filter presses for work on a large scale.

It is worthy of note that the appliances for treating the paraffin masses were mostly derived from the sugar industry which flourished in the Province of Saxony contemporaneously with the mineral oil industry; and even now, many upright presses originating from the sugar industry are still in use.

Attempts made to treat the strongly cooled paraffin mass direct in the hydraulic press without previously being put through the filter

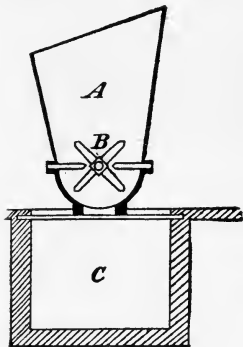

FIG. 51.—Mechanical crusher.

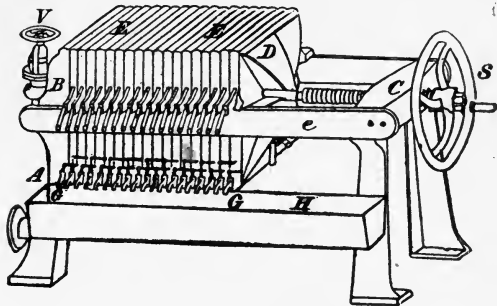

FIG. 52.—Filter press.

press had to be abandoned on account of the great waste incurred; and this method is unsuitable owing to the relatively low paraffin content of the masses.

The construction of the filter press is explained by Fig 52. The press is built entirely of iron, the frame A supporting the fixed head B, which is connected with the frame C (mounted on two uprights) by means of a couple of iron rods *e*. These rods act as guides for the movable press head D and the filter plates EE, which rest on the rods by means of lugs and are removable. Fig. 53 illustrates a filter plate, of which fifteen to twenty are inserted in the press. By means of a crank wheel and screw spindle S the filter plates are pressed together between the heads. In the centre of the filter plates, the edges of which make a series of perfectly tight joints, is an orifice F about 2 in. wide, so that these orifices, in conjunction with that in the fixed head, form a passage into which the paraffin

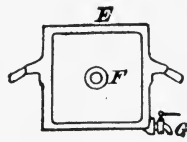

FIG. 53.—Filter plate.

¹ Eisenlohr and Busch, "Filterpressen" ("Filter Presses"), "Zeitschr. f. angew. Chemie," 1907, pp. 1393 *et seq.*

mass from the crusher is forced by the pump. The plates are recessed internally about three-fifths of an inch on each side, and a piece of perforated sheet metal is screwed over each recess. Each filter plate is also provided with a delivery channel, adapted to be closed by a tap G. Over each filter plate is stretched a canvas filter cloth, secured externally so as to be easily detachable; and when worn out can be replaced by a new one without interrupting the work for more than a short time.

When the plates have been pressed up together, the filter press can be started. The paraffin pulp is pumped into the channel formed by the apertures F. The oil, forced through the press cloths, runs into the delivery channels of the plates, and through the opened taps G into the gutter H, whilst the paraffin scale is retained between the filter cloths on adjacent plates and fills up the hollow spaces formed by the recesses. The oil in the gutter H is drawn off further. The pump feeds each filter press until the latter is full, whereupon the feed is stopped by the valve V and the mass diverted to another filter press, two or three of which are usually connected with a common feed main. This main is provided with a safety valve, set to lift at a pressure of 2 to 3 atmospheres and thus indicating when a filter press is full. The filled press is emptied by releasing the screw spindle S and separating the plates, the paraffin cakes being scraped from the cloths with wooden knives. A filter press will furnish about $1\frac{1}{2}$ cwt. of scale at each filling.

The press cakes still contain about 26 to 30 per cent of oil, and are transferred, for the removal of this oil, to the vertical hydraulic press, where they are subjected to a pressure of 100 to 150 atmospheres.

Fig. 54 shows a vertical press, about $6\frac{1}{2}$ ft. high. The upper press head A is supported by four columns; and the plunger, carrying an iron plate C, is guided by the lower press head B. The paraffin scale is packed in press cloths, 32 to 38 in. square, preferably made of wool on the inner side and flax on the outside. A charge of scale from one filter press will fill about ten such cloths, which are folded over to a square of 15 to 22 in. and superimposed on the plate C., each being covered by a slightly warmed plate of sheet iron. When the press is filled, the water is turned on and raises the plate and its load (guided by the four corner pillars), pressing the same against the upper head. The pressure is gradually increased, and the cakes are allowed to remain under full pressure for a short time. The oil is forced out, runs away and is united with the runnings from the filter press.

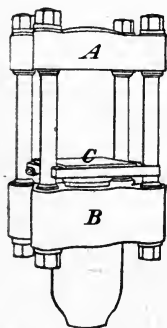

FIG. 54.—Vertical hydraulic press.

The $1\frac{1}{2}$ cwt. of scale from the filter press will furnish about 120 lb. of crude paraffin.

The several kinds of paraffin mass yield the following weights of crude paraffin:—

A-paraffin	mass	15-20 per cent,	melting-point	50-55° C.
B-	"	"	10-15 "	40-45° C.
C-	"	"	10-15 "	38-42° C.
Solar-	"	"	15-20 "	35-40° C.

The oils running from the filter presses and vertical hydraulic press are united, and are worked up in the manner indicated in Diagrams I and II.

In the earlier years many attempts were made at refining the crude paraffin, by treating it with sulphuric acid in the manner employed for refining ozokerite, whilst other chemicals, such as chlorine and sodium sulphide, were also tried. All these methods, however, were displaced by the mechanical process of washing the paraffin with light lignite-tar oils. Even the attempts made to introduce the sweating process for this paraffin proved unsuccessful, though it answers admirably in the Scottish shale industry (as will be described later) where it is the sole

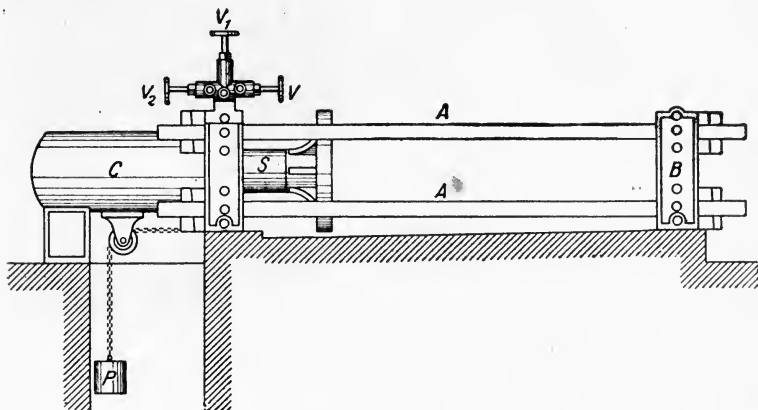

FIG. 55.—Horizontal hydraulic press.

method now in use. With lignite-tar paraffin, on the other hand, the final product is always dark in colour, owing to the presence of high-molecular hydrocarbons. The Scottish paraffin differs essentially in structure (fibro-crystalline) from that of the Saxon-Thuringian industry, and it is probably to this circumstance that their divergent behaviour under the sweating process is to be attributed.

The paraffin scale from the vertical press still contains 10 to 15 per cent of oil, which cannot be got rid of by pressure. For this reason, as already mentioned, the scale is washed by melting it by direct steam heat, in a vessel containing 10 to 12 per cent of benzine (light lignite-tar oil) of specific gravity 0.780 to 0.815, the two being mixed together and poured into water, whereupon the paraffin solidifies to a perfectly uniform mass. The layer of paraffin, about 1 in. thick, is cut into cakes and pressed in the horizontal hydraulic press, a lateral elevation of which is shown in Fig. 55. In build and method of

operation this press is similar to the upright one. The press head S moves between four iron rails A A, on the upper pair of which the press cloths are suspended by means of iron rods. These cloths are closed at the bottom only, and an iron plate of equal size is interposed between each pair. According to size, the presses will hold 30 to 60 press cloths. As in the vertical press, the pressure is produced by a hydraulic pumping plant and attains 200 to 250 atmospheres. By opening the valve V, the press head and charge are forced against the fixed head B, and the charge is left under maximum pressure for a short time, thus forcing out the contained oil, which collects in a gutter underneath the press and is led away. The oil is known as hard or soft oil, according to the class of paraffin.

To empty the press, the exhaust valve V_2 is opened, the plunger S being drawn back by the weight P into its original position. In some works the pressure is supplied by an accumulator with a constant working pressure of 25 atmospheres and connected with the press by means of the valve V. The accumulator is of the same type as those used in cement works.

In order to prevent the bursting of the cylinder casting C by excessive pressure, safety valves are attached to the hydraulic pumping plant; and in some works special safety appliances for the same purpose are arranged in the pressure pipe.¹

When the scale is pressed in the horizontal press, the light lignite-tar oil carries away with it the heavy oil adhering to the scale. This press oil, which is very rich in paraffin, runs down into a gutter under the press. The scale from the first pressing is remelted, mixed with benzine in the same manner as the crude paraffin, cooled over water and pressed again. If a first-class commercial article is desired, the paraffin from the second pressing is pressed a third time; but, as a rule, only two pressings are given. At each successive melting of the paraffin, benzine of lower specific gravity is used, so that, finally, the lightest grade of all is employed. Occasionally, the oil draining from the second and third pressings in the horizontal press is used, in place of benzine, for dissolving the paraffin scale.

In most works the presses are run both summer and winter without being warmed, and it is only seldom that heat is applied by means of steam pipes arranged near the presses. It is not the practice to use proper warm presses, such as are employed for pressing stearine, anthracene, etc.

The process of washing with benzine is attended with the drawback that, in many cases and especially with soft paraffin, a faint smell of the washing agent remains, in spite of careful after-treatment (blowing). Nevertheless, all attempts made to replace benzine by some other washing agent have failed up to the present. Olein, amyl alcohol, and other alcohols, and also carbon disulphide have all been tried; but the high price formed a deterrent on the one hand, and on the other their

¹ Scheithauer, "Die Fabrikation der Mineralöle," pp. 164 *et seq.*

application was found to be impracticable on a manufacturing scale. Amyl alcohol is put out of court by its smell, which produces headache; and carbon disulphide by its high fire risk. Further attempts were made to discover a washing agent capable of reacting chemically; and the pyridin bases used in refining anthracene are found suitable for this purpose, furnishing a beautifully white paraffin, which is rendered perfectly inodorous by treatment with sulphuric acid of specific

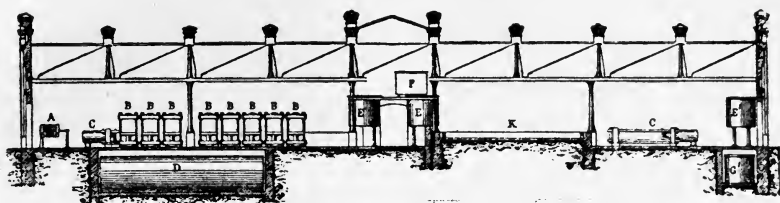

FIG. 56.—Longitudinal section of press plant.

gravity 1.26, this treatment readily eliminating the bases left behind in pressing. Unfortunately, the penetrating and disagreeable smell of the reagent precludes the application of this method in practice, though there would be no objection on the score of cost.

The experiments made to destroy the colour of semi-refined paraffin by chemical bleaching also proved a failure, the reagents used having either an injurious influence (ozone, chlorine) or being quite inert (sulphurous acid).

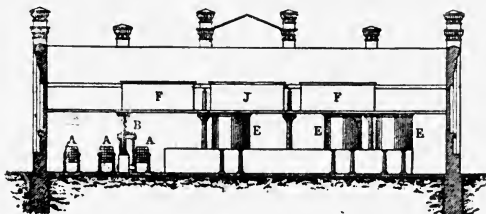

FIG. 57.—Cross section of press plant.

The Press Plant.

The press plant of the Webau works, Weissenfels (A. Riebeck'sche Montanwerke), is shown as a longitudinal section, cross section, and plan respectively in Figs. 56, 57, and 58. A A are the filter presses, B B the upright and C C the horizontal presses. The oil draining from A and B is collected into a pressure tank D, whence it is conveyed further by steam. The crude paraffin is melted in the other vessels E and mixed with benzene. These vessels are connected with the condenser J in which the benzene that is vaporized in E is condensed. The benzene is stored in the iron tank F. The coolers K K, which

are set in cement, are charged with water on to which the paraffin is poured out of E. The press oil collects in the pressure tank G, from which it is ejected by steam for further treatment. The finished paraffin is melted in the vessels E'E' and run off into the pressure tanks G'G'.

The outlay for press cloths of various kinds is a not unimportant item of expense in the manufacture of paraffin, and amounts to about 4½d. per cwt. of the finished article.

The Steam Jet Treatment.

The process of purification by pressing frees the paraffin from oils and makes it white in colour. Nevertheless it still contains in solution small traces, about 0.2 to 0.5 per cent, of the benzine used for washing, which cannot be got rid of by pressing, and imparts its own character-

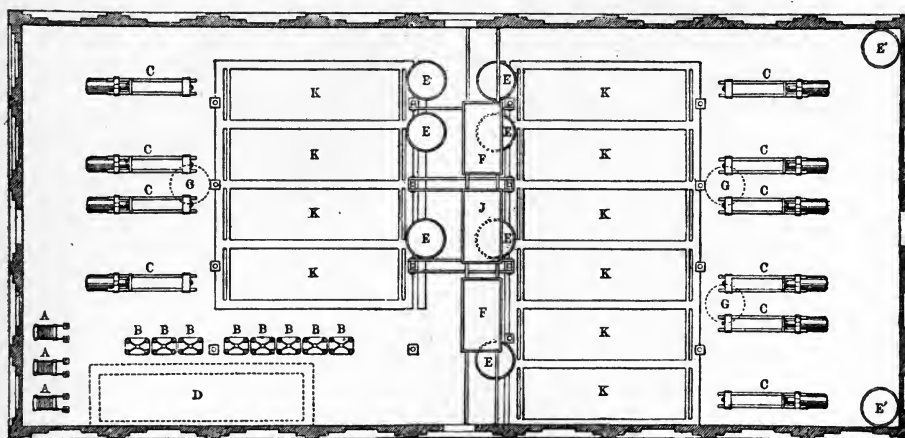

FIG. 58.—Plan of press plant.

istic smell to the paraffin. These traces of benzine are eliminated by treating the paraffin with a jet of steam.

For this purpose the paraffin is placed in vessels, which differ in various works, being retorts in some cases and cylindrical vessels in others. Here the paraffin is warmed by steam, and is subjected to the action of a jet of steam admitted at the bottom of the vessel. This steam carries away with it the traces of benzine vapours, which also contain a certain amount of paraffin and are preferably condensed in a suitable apparatus, the condensed product being returned to the manufacturing process. In some works the whole operation is carried on in a partial vacuum produced by a Koerting aspirator. The steam-jet treatment is continued for thirty to forty-eight hours, within which period hard paraffin can be rendered perfectly inodorous, though this condition is more difficult to attain in the case of soft paraffin. In the heating process preceding the admission of the steam jet, the paraffin must

be raised to a temperature that precludes condensation of the steam. During the steam-jet treatment itself the temperature must not exceed 140° C. but must be kept between 130° and 140° , since otherwise the paraffin would suffer decomposition. It is therefore inadvisable to employ strongly superheated steam, or steam at a pressure exceeding 4 atmospheres.

Decolorizing the Paraffin.

After the paraffin has been rendered inodorous by steaming, its colour is still of a faint greenish-yellow tinge, not pure white, and must be rectified by treatment with decolorizing agents. For this purpose animal charcoal was formerly used, but nowadays ferrocyanide residues and similar preparations are applied with success. In some works the decoloration was occasionally effected with clay,¹ but this has been abandoned. Quite a number of bleaching agents have been and are still recommended; but each manufacturer must ascertain by experiment the agent which will give the best results. Experience indicates that the decoloration of paraffin is best effected by a mixture of pure carbon and silicates. The process is a purely mechanical one, and is based on surface attraction.

The decolorizing powder must be thoroughly dried at a temperature of 100° to 110° C. previous to use, in order to make it perfectly anhydrous. This operation is carried on in ovens of various kinds, derived from other industries.

The decolorizing process entails the consumption of 1 to 2 per cent of the dry powder, there being, as a rule, no advantage in using any larger quantity. In some instances it is found preferable to divide the powder and perform the operation in two stages. When the powder has been added to the melted paraffin, the two must be intimately mixed together by means of mechanical or hand-operated stirrers, in a vessel heated to 70° or 80° C. by steam. For many reasons it is inadvisable to use air as the mixing agent. The mixing is continued for about half an hour, whereupon the mixture is allowed to rest, the decolorizing agent settling down to the bottom. The paraffin is then separated from the adjunct by filtering through paper. At one time very simple appliances were used for this purpose, but most works now employ filter presses, similar to those already described for paraffin scale, and kept warm by the aid of steam.

The spent powder contains large quantities of paraffin, which must be recovered. This is done by extracting it with benzine in apparatus which differ in almost every work. There does not seem any necessity for describing them in detail here.² They accomplish the desired object, the powder issuing perfectly free from paraffin. The once-used decolorizing powder is weakened to such an extent that it cannot be employed even a second time, nor can it be regenerated by calcination.

¹ Vehrigs, "Dingler," 270, p. 182.

² See also "Zeitschr. f. angew. Chemie," 1839; Allen & Holde's Ger. Pat. 106,119.

B. MANUFACTURE OF PARAFFIN IN THE MESSEL INDUSTRY.

Crystallization.

The paraffin mass is cooled and brought to crystallize in two stages.

Stage 1. The plant used for this purpose occupies only one-tenth the space required in the Saxon-Thuringian industry. The cylindrical cooling vessels are provided with automatic charging and discharging devices. To keep the vessels clean and accelerate cooling, a number of scrapers are caused to move vertically over the cooling walls. These scrapers do not stir up the mass at all, but merely allow the detached scrapings to slip down slowly to the centre of the vessel. The oils contained in the paraffin are not thin like those in the Saxon-Thuringian industry, but viscous; and even quiescent cooling does not give the same large crystals as those obtained in that industry. This drawback has been taken into consideration at Messel and counteracted in the subsequent treatment of the paraffin scale. The first cooling is effected successively with air and cooling water, down to a temperature of about 15°C ., at which temperature the mass is filtered for the recovery of hard scale.

Stage 2. The filtrate is subjected to a second cooling, in cold chambers, large jacketed cooling tanks being employed. The jacket spaces are traversed by cold brine from a refrigerating plant. The tanks are filled with the filtrate from stage 1, and the walls are scraped clean by rotary horizontal scrapers working at a very slow speed, which again do not stir up the mass at all. The buttery cooled mass is delivered in a continuous strand towards the centre by the scrapers, and contributes to the solidification of the mass there. At the same time the more fusible paraffin is redissolved, the crystals of the harder scale continuing to grow. As soon as the temperature has fallen to -3°C . throughout the tank, the mass—which does not require any breaking up—is transferred to filter-presses in the same chamber. By this means the temperature of the filtrate is kept down to -1°C ., so that it carries away only very small traces of paraffin.

The Pressing Process.

The filter cakes obtained in both cooling stages are freed from the slight residual traces of contained oil in vertical hydraulic presses, and removed for further treatment. The hard scale from the first stage melts at about 54° to 57°C ., and the soft scale from the second stage at 46° to 48°C .

The further treatment of Messel scale is effected in two ways. In the one method a doubly refined product is obtained by remelting with benzene (photogen) and subsequent pressing, as in the Thuringian industry, whilst the other treatment, by sweating, furnishes a product corresponding to semi-refined American paraffin. The scale intended for double refining is treated in advance with small quantities of acid and alkali, then distilled *in vacuo* with a current of steam, further refined by remelting, and finally decolorized, the colourless paraffin being

moulded into cakes. Candlemaking is not practised at Messel. The sweating process is similar to that adopted in other places and need not be more fully described.

C. PARAFFIN MANUFACTURE IN THE SCOTTISH INDUSTRY.

Crystallization.

The crystallization process is the same as in the Saxon-Thuringian industry. The hard-paraffin mass is cooled by air in shallow vessels, and the soft masses are cooled with brine reduced to a low temperature in a refrigerating machine. At one time small apparatus,¹ in which the operation was effected quickly, were used for crystallizing the soft paraffin. The usual practice was to dip a drum into the cooled mass, and scrape off the paraffin pulp setting on the surface of the drum. At present, appliances are used which obviate the drawbacks of the old method and enable the crystals to develop better, the cooling being more gradual. This paraffin pulp is more easily filtered than if interspersed with small undeveloped crystals.

Henderson's cooling apparatus² consists of a jacketed vessel, divided into small compartments by partitions, each of which forms a jacket and, like the main jacket, is traversed by a cool solution of calcium chloride. The paraffin crystals attach themselves to the partitions, from which they are removed by slowly revolving scrapers. New crystals are continually deposited and scraped off, and the pulp collects at the bottom, falling into a channel from which it is moved by a worm conveyer into a pipe connected with a pump, which forces the pulp into the filter press. Large quantities of paraffin mass can be cooled down in such a vessel; but as the mass is not left at rest to crystallize, except for a short time, the crystals are not so well developed as in the Beilby cooling apparatus. In this latter the soft-paraffin mass is cooled slowly in a series of rectangular cells by the aid of a refrigerating machine for four days, whereby large crystals are formed. The cooled mass is led away at the bottom of the apparatus and delivered to the filter press.

In some paraffin works the paraffin mass is led through pipes which are strongly cooled by the direct evaporation of ammonia in the cooler. The rapid cooling, however, causes the paraffin to deposit in imperfectly formed crystals, which are difficult to separate from the oil.

The filter presses are generally larger than those used in the Saxon-Thuringian industry, but accomplish the same purpose.

The Sweating Process.

The scale from the filter presses is packed in linen cloths and treated in hydraulic presses, crude paraffin being obtained. In some works the scale obtained from the press is refined direct. At one time the refining of the crude paraffin was performed in the same manner

¹ Scheithauer, "Die Fabrikation der Mineralöle," pp. 176 *et seq.*

² "Chemical Technology," 2 ("Lighting"), pp. 135 *et seq.*

as in the Saxon-Thuringian industry, being melted, repeatedly mixed with shale benzine, and pressed, this treatment being followed by steaming and bleaching. This treatment, however, has for some years now been abandoned in almost all cases, being replaced by the sweating process, which in turn has been successively modified and improved. A few of the most widely extended methods will now be described in order of time, leaving out of consideration such imperfect experimental methods as were only used temporarily.

The crude paraffin, a mixture of hard and soft scale, is melted and allowed to set in the form of cakes. These cakes are transferred to the sweating house, where they are laid on stretched cloths. The temperature of the room is maintained, by the aid of steam heating apparatus, at a constant level, 3° C. below the melting-point of the crude paraffin. The brownish-red oil, accompanied by the paraffin of low melting-point, drains out of the cakes into a gutter underneath the band of cloth, and is returned to the manufacturing process. The sweating process usually takes three to five days,¹ and is repeated, but only rarely more than once. The residual paraffin is in a refined condition, being free from the oily and odorous constituents, and is decolorized by treatment with decolorizing powder.

Tervet and Allison's sweating process requires a cooling house and a sweating house, each of which is divided into three sections, so that three grades of paraffin can be treated at the same time. Each section of the cooling house holds twenty enamelled cast-iron pans traversed by a light canvas belt. The pans are filled with melted paraffin, which solidifies gradually. A number of racks carrying corrugated steel trays, corresponding in number and size with the cooling pans, are arranged in the sweating house, which is maintained at the desired temperature by steam heating apparatus. After being cooled down in the cooling house, the paraffin in the form of cakes is transferred on the canvas belt, which is operated by a hand winch, to the sweating house. Here it breaks to pieces in passing over the corrugated trays, and the oil and paraffin of low melting-point drain away into a gutter, whilst the residual paraffin is removed, by mechanical means, to a melting vessel outside the sweating house.

Another sweating process, simpler than those already described, was devised by M. Henderson.² The sweating house, which is 56 ft. long, $16\frac{1}{2}$ ft. wide, and 10 ft. high, is fitted with iron stands supporting troughs which are provided with double bottoms, the upper one being formed of fine-mesh wire gauze. These troughs, which are 23 ft. long and 6 in. deep, are filled with sufficient cold water to cover the false bottom, on to which the paraffin (previously melted outside the room) is run until the troughs are quite full. The wide doors of the room are thrown open, and fans are set running. When the paraffin has solidified, the water is drained off, and the paraffin cakes rest on the

¹ A full description of the Pühälä sweating process is given in "Petroleum," 4, p. 1393, and "Braunkohle," 8, p. 421.

² "Oil Shales of the Lothians," p. 179.

gauze. The room is converted into a sweating house by closing it tightly and starting the steam-heating apparatus; whereupon the paraffin sweats, the drainings running away through the gauze to the bottom of the troughs, and being carried away. When the sweating

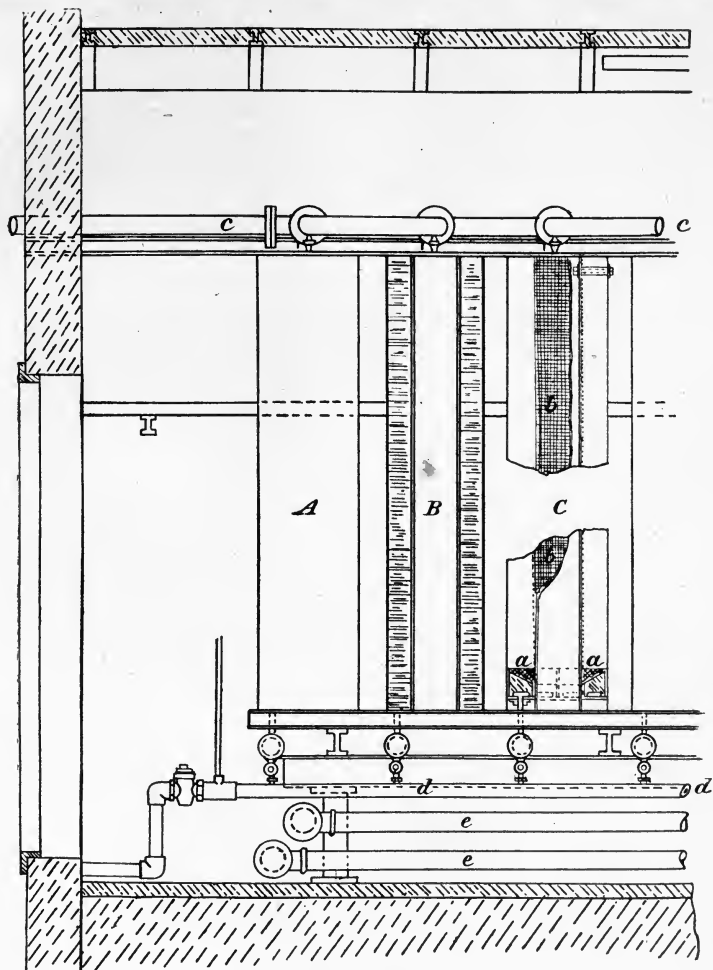

FIG. 59.—Sweating apparatus.

is completed and the drainings are removed, the temperature of the room is heightened, so that the refined paraffin also can be melted and removed in the liquid condition. If insufficiently refined by this first treatment, the paraffin is put through the sweating process again.

The newest sweating apparatus patented by M. Henderson is illustrated in Fig. 59. Instead of troughs, the paraffin is placed in deep

upright cells A of circular section and containing a wire-gauze covered cylinder *b*. The bottom *a* of each cell is also of wire gauze. The inner gauze cylinder is intended to act like a wick and facilitate the draining away of the oil during the sweating process, which is conducted in the manner already described. B (Fig. 59) represents a longitudinal section of the sweating cells, and C shows their internal arrangement. The cells are filled by a pipe *c*, and emptied through *d*. Heating pipes are shown at *e*.

According to the report of the Broxburn management, this apparatus is of much higher capacity than the older type, the paraffin solidifying much quicker and the sweating process taking less time.

Originally, the melted paraffin was intended to be cooled in the cells by means of air alone, but the scope of the Patent was subsequently extended by suspending the cells in a vessel of water, and thus cooling them.¹

In spite of repeated sweatings, the resulting paraffin is sometimes yellow in colour and cannot be whitened by this means.

The drainings, a mixture of oil and soft paraffin, are usually sweated (of course at a lower temperature) for the recovery of the soft paraffin.

Decolorizing the Paraffin.

After the sweating process the paraffin (all grades) is treated with decolorizing powder in the same manner as in the Saxon-Thuringian industry. Various types of filter are used for the mixture of paraffin and powder, that of Young, for instance, consisting of a steam-jacketed vessel containing a wire gauze cylinder faced with flannel and filter paper.

¹ So far as the author is aware, the wet sweating process now used in several paraffin works in Galicia, is not employed in Scotland. In this process the cooling water remains in the cells during the sweating process. The cells having porous walls, the sweated oil collects on the water (which flows continuously) and is removed with same and separated therefrom. Reference may also be made to the Wiesner combined pressing and sweating process used at Mähr-Schönberg ("Petroleum," 5, p. 636.)

CHAPTER VIII.

PRODUCTS FURNISHED BY SHALE OIL AND LIGNITE TAR.

A. PRODUCTS OBTAINED IN THE SAXON-THURINGIAN INDUSTRY.

Quantitative Yield.

THE lignite tar now treated gives the following average yield of products:—

Light lignite tar oil (benzine)	2— 3 per cent.
Solar oil	2— 3 "
Pale vaseline oil	10—12 "
Gas oil	30—35 "
Heavy vaseline oil	10—15 "
Hard paraffin	8—12 "
Soft paraffin	3— 6 "
By-products	4— 6 "
Water, gas, and loss	20—25 "

The Oils.

The oils, rendered marketable by distillation and refining, are run into open iron tanks holding 10 to 30 tons, where they are left to settle, in order that any residual water may separate out and the oils may become clear and transparent, free from any turbidity. The tanks for the heavy oils are fitted with a heating device consisting of coiled or gilled pipes, laid in the bottom of the tank and heated by steam. A steam trap is provided in each case.

When the demand for oils fails to keep pace with the production, considerable stocks of some grades are occasionally accumulated, and for this reason each works must be equipped with ample storage accommodation. At one time, rammed concrete or bricked pits faced with cement were used for this purpose, but are now seldom employed, iron vessels being the rule. The dimensions vary considerably,¹ but the shape is generally cylindrical. Unless embedded in a bricked pit, the tank is mounted on a foundation consisting either of brickwork or sand, covered with a layer of asphalt. In addition to cylindrical tanks, several constructed in accordance with Intze's Patent² (Fig. 60) have been erected by the A. Riebeck'sche Montanwerke. The top and bottom sections of this tank are conical, and the centre is traversed by a cylin-

¹ Probably the largest tank of this kind is that at the Reussen works of the A. Riebeck'sche Montanwerke, its capacity being 770,000 gal.

² Ger. Pat. 24,951, "Journ. f. Gasbel.," 1884, p. 705.

drical shaft *a* fitted with a ladder. The whole is mounted on an annular foundation, thus leaving the bottom visible; and the space underneath the tank bottom can also be utilized. One advantage of this type of construction is the relative cheapness and compactness of the annular foundation, another being that the entire surface is open to inspection so that leaks can be readily detected.

The oil is racked into casks either direct from the large storage tanks or from the small iron tank; but of late years, tank cars have grown

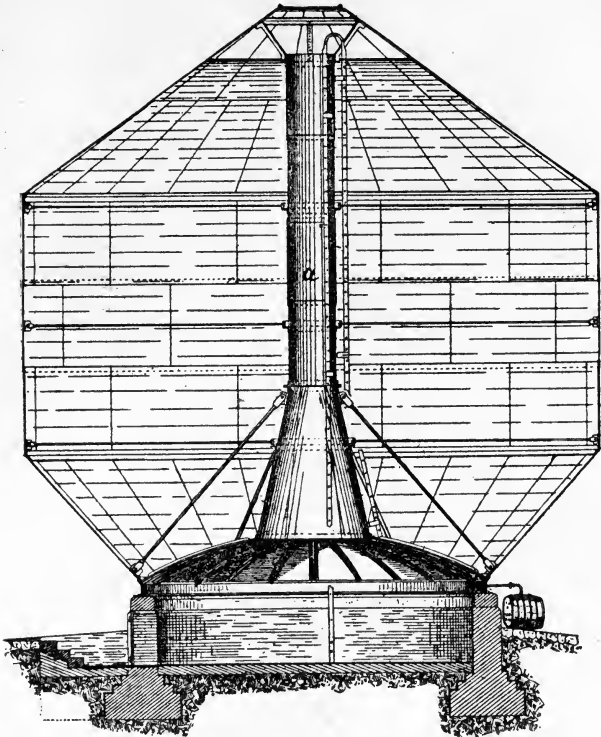

FIG. 60.—Cylindrical tank—Intze patent.

in favour in place of casks, so that now only about 20 to 25 per cent of the oil sold by the Halle Syndicate is sent out in the latter.

The casks consist of American barrels that have already been used for the conveyance of petroleum. Before being filled, the barrels are thoroughly cleaned out by swilling and steaming; and in some works they are also relined with glue. They are, however, getting scarce, and sell at high prices when in good condition, the reason for the scarcity being that the American oil companies now send out very few casks, most of the oil being exported in tank steamers.

Glass carboys holding about 11 gal. are no longer used, as formerly, for the conveyance of the oils.

Particulars will now be given of the properties and uses of the oils produced.

The light lignite-tar oil, or benzine, has the specific gravity 0.780 to 0.810, contains traces of creosote and flashes at 25° to 30° C. or higher. Analysis by distillation yields 20 per cent of fractions boiling between 120° and 150° C. (boiling commences at 100° to 120° C.), 80 to 100 per cent of the oil distilling over up to 200° C.; colour, water-white with blue fluorescence. This oil is consumed on the premises for refining paraffin, but at one time it was sold as a lamp oil under the name "Photogen".

Solar oil has the specific gravity 0.825 to 0.830. It is usually free from creosote, and flashes at 45° to 50° C. Colour same as that of the benzine, but with a slight tinge of yellow. Analysis by distillation: commencement of ebullition 150° to 170° C.; fractions up to 200° C., 40 to 50 per cent; up to 250° C., 80 to 90 per cent, the remainder boiling up to 250° to 270° C. Viscosity (Engler) 1.05 to 1.10. This oil was formerly used solely in lamps, but now replaces petroleum as motor oil. The high flashing-point is worthy of being borne in mind as affording increased security against fire during storage.

When used as lamp oil, solar oil needs a different class of burner to that for ordinary petroleum, since, on account of its higher percentage of carbon, it requires an abundant supply of air to keep the flame from smoking.¹ Its good illuminating properties have been demonstrated analytically by Grotowsky and others.²

The production of solar oil is small in comparison to what it was in the earlier days of the industry; but the output finds a market for the purposes stated.

Solar oil can also be used for other purposes instead of petroleum. It makes very good lampblack, and is employed to kill the "fly" infesting grape vines.

Pale vaseline oil is a generic term applied to the commercial varieties known as: yellow oil, red oil, and cleaning oil. The specific gravity of cleaning oil is 0.848 to 0.850, that of yellow oil being 0.860 to 0.870 and that of red oil 0.870 to 0.880, the colour being pale yellow, straw yellow, and red respectively. Creosote content 0.1 to 1 per cent. According to the analysis by distillation, these oils contain little or no constituents boiling under 200° C., the red oil in particular. The commencement of ebullition is generally at 200° to 210° C., 20 to 70 per cent passing over up to 250° and 90 to 100 per cent below 300° C. The viscosity, as determined in the Engler viscosimeter for lubricating oils, varies between 1.2 and 1.5, and the flashing-point is between 90° and 110° C. These oils solidify at -10° to -15° C., and—the red oil in particular—contain small quantities ($\frac{1}{2}$ to $\frac{1}{4}$ per cent) of irrecoverable paraffin in solution. In contrast to solar oil, they are free from naphthalene.

¹ Scheithauer, "Die Fabrikation der Mineralöle," p. 186.

² "Zeitschr. f. Berg.-Hütten-u. Salinenwesen," 24.

As its name implies, *cleaning oil* is used for cleaning; it is also occasionally employed as a solvent in extraction processes, but rarely as gas oil. The heavier, yellow, and red oils find application in the preparation of better quality wagon greases, and sometimes for mixing with petroleum lubricating oils; their chief use, however, being in the production of oil gas. They have also found employment, to a limited extent, for denaturing rock salt instead of petroleum.

The *dark vaseline oil, or gas oil* has the specific gravity 0.880 to 0.900, and is of a red-brown colour with blue fluorescence. It contains 1 to 2 per cent of creosote, and has a viscosity of 1.5 to 2.5. Distillation analysis; commencement of ebullition 200° to 300° C.; fractions passing over up to 250°, 5 to 15 per cent; up to 300°, 40 to 60 per cent. The flashing-point is between 100° and 120° C. and the setting point zero to - 5° C. Calorific power 10,500 to 10,800 cal. As its name indicates, gas oil forms the raw material for the production of oil gas by methods which have already been fully described by the present author elsewhere.¹ All that need now be mentioned is that this dark vaseline oil has been used for the said purpose for a number of years, and that it fulfils all the requirements of a good gas oil. The yield of gas is about 875 to 975 cub. ft. per cwt. of oil, and the illuminating power of the gas is 12 to 16 Hefner units. A suitable apparatus is an essential condition to the production of oil gas, and careful management of same is also required, experience showing that the fulfilment of these conditions prevents failures due to insufficient yield, etc., which are sometimes erroneously ascribed to the raw material. As is well known, the chief employment of oil gas is for lighting railway carriages. Now that the use of an admixture of acetylene has been abandoned on most railways in favour of oil gas and incandescent burners, it is no longer necessary to produce gas of high illuminating power, and a higher yield can be obtained. Exhaustive experiments on this point were carried out by Walter Hempel.²

For a number of years gas oil has been successfully used for carburating water gas. About 25 lb. of oil are needed per 1000 cub. ft. of gas with the usual illuminating power of sixteen candles.

Water gas,³ as is known, is made by passing steam over glowing coke and consists essentially of carbon monoxide and hydrogen. It is rendered luminous by an addition of oil gas. The water gas is made in a cylindrical iron producer, lined with firebrick; and the gas is conveyed from the producer to the carburettor, where an accurately measured quantity of oil is injected in the form of spray. The carburettor is a vessel similar to the producer, and is filled with firebricks set crosswise one above another. Consequently the gas, striking against these bricks on its way through the apparatus, is obliged to change its

¹ Scheithauer, "Die Fabrikation der Mineralöle" (Brunswick, 1895, Chapter 12; "Die Braunkohlenteerprodukte und das Oelgas" (Hanover, 1906), Chapter 8.

² A Report on the Production of Oil Gas from Gas Oil, "Verhandlungen des Vereins zur Beförderung des Gewerbefleisses," 1903, 39.

³ Ferd. Fischer, "Kraftgas," pp. 81 *et seq.*

direction constantly, and the oil is vaporized by contact with the glowing bricks. The gas, laden with oil vapours, then passes to the superheater, the arrangement of which is similar to that of the carburettor, and which like the latter is raised to a uniform cherry red heat during the gas-making process. In the superheater the oil vapours are transformed into oil gas; and the carburetted water gas is then passed through the washer and scrubber, and thence to the condenser, whence, freed from tar, and cooled, it is led to the gasholder.¹

The preparation of carburetted water gas presents many advantages over the manufacture of coal gas, the prime cost of the plant, for example, being only about two-fifths that of coal gas plant of equal capacity. The floor space occupied is only about one-third that of coal gas plant—a highly important feature in the case of large towns. The plant is very easily started and can be worked with a small number of hands—which is also important in the event of a strike. Moreover, the water gas plant is the indicated consumer of gasworks coke, the latter establishments being therefore enabled to regulate the price of their coke. At present the chief purpose for which water gas plants are erected is to supplement existing coal gas plants: for example at Bremen, Hamburg, Magdeburg, Flensburg, Koenigsberg, Charlottenburg, and other towns.

Another important use of dark vaseline oil is as fuel for Diesel motors,² which differ essentially from the other motors consuming mineral oils, such as petroleum, solar oil, and benzine. These motors are of the internal combustion type, the liquid fuel being vaporized, mixed with air, and the mixture ignited by an incandescent tube or electrical igniter. In the Diesel motor on the other hand, the fuel—consisting of oils of higher boiling-point than either petroleum or solar oil—burns spontaneously.

The Diesel motor is single-acting and of the 4-cycle type. The piston stroke draws in air, which is compressed during the return stroke, the liquid, but finely sprayed, fuel, being then forced into the strongly compressed and therefore hot air. The mixture burns and the products of combustion propel the piston forward quietly but with great force. This movement of the piston is transmitted through a connecting rod to the crank shaft, and thence by a belt or direct coupling. The following return stroke of the piston expels the products of combustion. It should be noted that, during the first stroke—that is to say, before the fuel burns in the glowing air—the motor works as an air engine. On this account it is provided with two compressed-air cylinders for use in starting it for the first time, after which the motor produces its own supply of compressed air by means of an

¹ An exhaustive description of the manufacture of carburetted water gas by the Humphreys process is given in a pamphlet issued by Julius Pintsch, Berlin, the well-known makers of this type of gas plants.

² "Braunkohle," 3, p. 539; "Zeitschr. f. Dampfkessel u. Maschinenbetrieb," 1907, No. 20.

attached air pump, which also forces into the cylinder the oil fed by another pump.

Over 1000 Diesel motors, ranging in capacity from 8 to 400 h.p., and driven by gas oil from distillation tars or by petroleum, are already in use.

A motor (the Trinkler motor) similar in principle to the Diesel motor is constructed by Gebrüder Koerting, A.G. of Koertingsdorf near Hanover; but is of the horizontal¹ type and is equipped with an injector which works without valves or any special pressure vessel. A number of these motors are also in use.

Apart from the low working costs, these oil motors present manifest and great advantages over other prime movers, and in particular—so far as other oil motors are concerned—the fact that the fuel used has a low fire risk, the ignition point of the gas oil used being, as already stated, about 190° C. and over.

Gas oil is also used in making cart grease and for steam raising purposes, having a calorific power of 10,800 cal. The heavy vaseline oil obtained from lignite tar is also suitable for the same purposes. This oil has the specific gravity 0.905 to 0.920, contains 1 to 3 per cent of creosote, and has a viscosity of 2.0 to 2.66. It flashes at 115° to 125° C. and is dark brown in colour with a greenish fluorescence. Distillation analysis gives the following data: commencement of ebullition 220° to 250° C.; percentage distilling over up to 250°, 5 to 10 per cent; up to 300°, 10 to 20 per cent.

It was largely used for steam-raising purposes by the German navy in the middle of the "nineties". The prices, however, which it fetches for this purpose are so low that makers prefer to sell it for other uses when possible. The use of oil fuel *per se* is attended with great advantages.² Petroleum residue (masut) has been employed in this way for several decades in Russia, for steamships and locomotives, and is of special importance for naval work, the calorific power that can be stored in the form of oil being double that of coal of equal volume and weight, so that space and cost of transport are saved. Other advantages of oil fuel are the absence of smoke and ash, the considerable saving in stokers' wages, and the great cleanliness that can be maintained in the stokehold. The oil is atomized by a steam jet (forsunka burner) before ignition.

A small quantity of oil—*Fat Oil*—red or brown in colour, and similar in density and constitution to the heavy vaseline oils, is also obtained from distillation tars. It is sold either in the crude state, or after a process of chemical refining, the latter quality being of a yellow colour, free from creosote, and of specific gravity 0.890 to 0.905. This fat oil is used in making fine lubricants, and occasionally as gas oil.

All the vaseline oils, and fat oil as well, can be used for making

¹ The Maschinenfabrik Augsburg-Nürnberg has recently introduced a horizontal pattern of Diesel motor.

² Exhaustively described in the "Petroleum Review," 20, No. 450, p. 275.

lamp-black, but their employment for this purpose is far smaller than was formerly the case.

Several works manufacture from the heavy vaseline oils a lubricating oil which occasionally sells freely at good prices. It is, however, inferior to the lubricating oils from petroleum, having a much higher specific gravity and lower viscosity, its capacity to stand low temperatures being also inferior to that of the petroleum lubricating oils.

All the vaseline oils above specific gravity 0.880 still contain small quantities of paraffin, increasing in amount with the specific gravity. This paraffin, however, does not separate out until the oil is cooled to a very low temperature, and is, moreover, not crystalline but of the consistence of ointment. It must, as a rule, be regarded as non-recoverable.

The By-products.

The creosote oil (specific gravity 0.940 to 0.980) contains 40 to 60 per cent of creosote, and the greater portion of it is soluble in sulphuric acid of 66° B. strength. The distillation analysis gives the following results: commencement of ebullition 150° to 170° C.; fractions passing over up to 200°, 5 to 10 per cent; up to 250°, 30 to 40 per cent; up to 300°, 60 to 70 per cent.

Creosote oil is used as a disinfectant, and occasionally for impregnating timber. For the former purpose it is equal in value to the oils from coal-tar. Its objectionable smell is due to the presence of sulphur compounds. The oil may also be employed for making lampblack and for steam raising.

The paraffin grease is used as an adjunct in the preparation of asphaltum products and lubricants, but is not met with largely as a commercial article.

The soda-tar, which in the undiluted condition contains nearly 50 per cent of creosote, is used in lignite mining as an impregnating material for the pit timbers, for which purpose the low flashing-point of creosote oil renders the latter unsuitable. The creosoting process is carried on in closed tanks, and has been fully described by Vollert.¹

The creosote contains up to 30 per cent of water, but only a little oil, and is almost completely soluble in caustic soda of 38° B. strength. It is sold in this condition, and is either used as a disinfectant or else sent for purification.

The asphaltum, lignite pitch, is usually sold in loose blocks, or more rarely in open casks and metal drums, or broken in pieces and packed in bags. It is brittle, has a conchoidal fracture and a shiny, deep-black appearance. It softens at 60° to 70° C. and melts at 90° to 100° or over. It is used for mixing with natural asphalt, and when dissolved in oil of turpentine, benzine or benzol, may be employed in the preparation of lacquer varnishes.

The "goudron" is also black, but is softer than the asphaltum,

¹ "Der Braunkohlenbergbau im Oberbergamtsbezirk Halle a. S.," pp. 161 *et seq.* ("Lignite Mining in the Halle District").

being of about the same consistence as soft-bread. It can be kneaded between the fingers. Two kinds of this goudron are known in commerce: the one obtained by the distillation of oils is much softer than that from refinery waste, and is therefore higher in price. A softer variety, with a larger oil content, is known as oil goudron.

Goudron is put on the market in closed casks and is mixed with paving asphalt and wood cement, as also as an insulating material for building purposes.

The employment of the retort coke has already been described (p. 76).

Up to the present it has been found impracticable to manufacture pure tar acids on a large scale, and the prospects in this direction are slight.

On the other hand, the recovery of purified nitrogenous bases has been successfully carried on in several works (see p. 91), an impetus being given by the employment of the pyridin bases for denaturing spirit, in accordance with the German Law of 24 June, 1887. Owing, however, to their low content of pyridin—the series of bases commencing essentially with the two picolins—these bases from lignite tar proved incapable of satisfying the subsequent, more stringent requirements, and they very soon lost this market. Their uses in other respects being very restricted—for instance in the purification of anthracene according to Ger. Pat. 42,053—the manufacture of these bases never attained any great extent in the mineral oil industry. The only commercial articles of any importance were the products boiling at 200° C. and between 200° and 250°; and the far more preponderating bases of higher boiling-point have not yet even been isolated.

The Paraffin.

The solid hydrocarbons, of the fatty series, recovered from distillation tars are known, commercially and technically, as paraffin.

Paraffin is the most valuable of the commercial products of the industry, and its proportion largely influences the value of the distillation tar. In its refined condition the paraffin from the lignite tar is colourless, of crystalline structure and translucent with a bluish tinge. It is not milky, but transparent, and is therefore regarded with favour in commerce.¹ It feels dry, not greasy. The harder kinds are resonant and lustrous, the softer grades dull in both respects. Paraffin is soluble in lignite-tar oils, benzol, chloroform, ether, carbon disulphide, and carbon tetrachloride, as also in all volatile and fatty oils. It is only partially soluble in amyl alcohol and hot ethyl alcohol, and quite insoluble in the latter when cold. In the melted condition it is miscible with spermaceti, wax, stearine, resins, and animal and vegetable fats.

Paraffin is capable of resisting acids and bases to a certain extent; but though unattacked by hydrofluoric acid is susceptible to the action of nitric acid and chromic acid.

¹ "Chem. Ztg.," 1906, 61.

The melting-point of the paraffin manufactured at the present time varies between 35° and 62° C., though at one time still softer grades, melting as low as 27°, were produced. Grades melting below 50° C. are classed as soft paraffin, and those of higher melting-point as hard paraffin.

Paraffin ignites at 160° to 165° C. and volatilizes at 350° to 400°. The specific gravity rises with the melting-point, being, at 20° C., 0.883 for the grade melting at 45°, 0.908 for that melting at 51°, and 0.915 for that melting at 58° C. According to Bolley, the specific heat of paraffin is 0.683. It is a non-conductor of heat and electricity; and, according to Edison, its insulation resistance amounts to 110 megohm-centimetres. Though, under the influence of Röntgen rays, air becomes a conductor of electricity, this is not the case with paraffin.

For sale, hard paraffin is cast in dished moulds holding about 2½ lb. These moulds float on the surface of the cooling water, and are immersed as soon as the surface of the paraffin has set to such a degree as to be impermeable to water. Owing to the difficulty of detaching soft paraffin from the moulds, this grade is not cast, but is allowed to cool, in a layer about 1¼ in. thick, on the surface of the cooling water, and is then cut up into cakes of suitable size.

Paraffin of low melting-point (35° to 40° C.) is also sold in the crude form as scale, and is used mainly in the manufacture of matches, the annual consumption for impregnating match sticks being 800 to 1000 tons. The extent of this industry may be gathered from the fact that the paraffin used is equivalent to only 5 to 8 per cent of the total weight of the output. The crude paraffin is broken up in simple crushers or centrifugal mills, from which it is delivered, as a white powder, into casks, in which it is rammed down.

The chief use of paraffin is for moulding candles, a process which will be fully described in the next chapter. Candle factories are attached to several of the mineral oil and paraffin works in the Saxon-Thuringian industry. Statistics showing the extent of this branch of manufacture will be found in Chapter XII.

Paraffin also finds employment in various other ways. It is used for impregnating paper, linen, and leather; as a dressing for textile fabrics, and for finishing turned articles of animal and vegetable fibre. It forms a valuable insulator, and is used as a substitute for oil baths in chemical laboratories. In the pharmaceutical industry it serves as a binding medium for ointments, and for sealing vessels. In the toy-making industry it is used to make the waxy covering on dolls' heads; for feeding lamps in glass-blowing works, and for cooling baths in the production of hardened glass. The interior of vessels, casks, etc., is coated with paraffin, to prevent the contents from tasting of the wood. Paraffin is also used as an impregnating material in breweries.¹ Of late it has become the custom to employ a bath of melted paraffin to impart a permanent brown colour to sword scabbards by dipping the red-hot steel in same.

¹ "Chem. Centralbl.," 1908, No. 6.

B. THE PRODUCTS OF THE MESSEL INDUSTRY.

Yield obtained from the Tar.

The distillation tar (crude oil) produced at Messel yields:—

Naphtha	4.0 per cent.
Gas oil	63.0 "
Crude paraffin	7.5 "
Gas, coke, and loss in refining	25.5 "

The Oils.

The oils coming under consideration are: gas oil, motor spirit, cleaning oil, fat oil, spindle oil, and lubricating oil.

As mentioned on p. 36, in the distillation of Messel coal it is not necessary to take into account the destruction of the bitumen which impedes the refining of the crude oil. The dry-distillation process can be carried on in a current of steam so as to afford extensive protection to the purely fatty character of the oils. As a result of this circumstance, Messel gas oil is distinguished by high gasification value. Its specific gravity is low, ranging between 0.865 and 0.872.

The motor spirit has the specific gravity 0.800, and is extensively used in petroleum engines.

Cleaning oil consists of the fractions with specific gravity 0.825 and 0.835.

The fat oil has the specific gravity 0.860. The lubricating oil has the specific gravity 0.090 to 0.892, and is used for light machinery.

The Paraffin.

The paraffin is distinguished by its waxy character and very small crystalline structure, and is not pulverulent.

There is no need to discuss more closely a number of smaller products such as tumenol, pyrocatechin, etc.

C. THE PRODUCTS OF THE SCOTTISH INDUSTRY.

Yield from the Crude Oil.

At present, the crude oil furnishes:—

Naphtha	3—5 per cent.
Lamp oil	20—25 "
Medium oil (gas oil)	15—20 "
Lubricating oil	15—20 "
Hard paraffin	7—9 "
Soft paraffin	3—5 "
By-products	2—3 "
Water, gas, and loss	25—30 "

The Oils.

In order to finish off the oils intended for sale, they are put into shallow wrought-iron tanks, about 13 ft. long, 40 in. wide, and 2 ft. deep. Steam coils are arranged underneath these tanks, but must not be laid on the bottom of same, since the oils would be darkened in colour if brought into contact with hot surfaces. The oil is kept at

a temperature of 35° to 40° C. (95° to 104° F.) until clarified, whereupon it is run into barrels through a tap provided some distance above the bottom of the tank. The water separating out from the oil is drawn off through a tap at the bottom. Automatic apparatus is used for filling the barrels.

Several grades of benzine are put on the market, the lightest (specific gravity 0.600 to 0.690) being used for the production of air-gas and as motor spirit. The ordinary naphtha (specific gravity 0.725 to 0.745) is burned in special lamps for lighting workshops, yards, etc. This benzine also finds employment as a solvent of various substances such as fats, gum, resin, etc. All the benzenes are colourless and have low boiling-points.

The oils of specific gravity 0.785 to 0.830 are used as lamp oils in lamps of various patterns.¹ The oils are colourless, the heavier kinds alone having a yellowish tinge. The flashing-point is 52° to 53° C. (125½° to 127½° F.), and the oils are therefore very safe.

The lightest oil—water-white oil—of specific gravity 0.785 is used for continuous lighting in buoys and lightships; and is also employed as motor spirit. Another light oil—lighthouse oil—is used, as its name implies, as an illuminant for lighthouses.

The medium oils, corresponding to the light and dark vaseline oils of the Saxon-Thuringian industry, are yellow to dark red in colour and have the specific gravity 0.840 to 0.870. The flashing-point is above 68° C. (155° F.). The more volatile members are used as cleaning oil, but their chief employment is as gas oil for producing oil gas. Like the same oils of the Saxon-Thuringian industry, they may be used for carburetting water gas, as motor oils and for steam raising.² The grades known as "Intermediate I and II," and also the "blue oil," belong to this group.

Lubricating oils of specific gravity 0.865 to 0.910 are made. They are yellow or dark in colour, and may be regarded as lubricants of medium quality. They are sold both pure, and mixed with vegetable or animal oils.

The By-products.

Paraffin grease is recovered in some works by distilling the tar or heavy oils, as in the Saxon-Thuringian industry, and is used in making cart grease.

The uses of the waste products of the refining process have already been described (p. 94). The mixture of acid resins and soda-tar is clarified by boiling, and is then used for impregnating timber, for mixing with asphaltum, and for painting ironwork.

The Paraffin.

Owing to the method of preparation, the paraffin is somewhat different in character from that obtained in the Saxon-Thuringian industry.

¹ Fully described in "Chemical Technology," pp. 243 *et seq.*

² As might be expected, the tests carried out in the English Navy proved satisfactory. Gräfe, "Die Schottische Schieferteerindustrie"; "Petroleum," 6, 79.

The melting-point varies between 43° and 59° C. (117° to 138° F.), small quantities of a softer grade (melting-point 100° F.) being also produced. The paraffin has no decidedly crystalline structure, is not translucent, and does not exhibit the bluish tinge. It is sticky and can be drawn out if slightly warmed ("drawn paraffin").

It is chiefly used for making moulded candles; but, owing to its properties as described, is difficult to detach from the moulds—a point that has to be taken into consideration. In other respects it is suitable for the same purposes as the product of the Saxon-Thuringian industry. The soft paraffins are employed either in making matches or as an illuminant for miners' and ships' lamps.

CHAPTER IX.

CANDLEMAKING.

HISTORICAL.

PROBABLY in no other branch of industrial life has such great progress been made in the course of time, or such great contrasts presented between formerly and now, as in the lighting industry. One stage in the history of this branch is formed by the candle, which has been developed from a primitive type to the perfectly burning illuminant now produced in numerous forms.

The earliest primitive illuminant was the camp fire, built up of logs. Later on, when man abandoned his nomadic habits, settled down and built huts, the camp fire was replaced by that on the domestic hearth, round which the family gathered in the evenings, as described by Homer,¹ who also spoke of the discomfort caused by the smoke. Apart from the fire, the torch was used, as the only portable light; and the torch sconces are also described by the same Greek poet. The earliest torches were made of pine splinters; and subsequently bundles of twigs or vine stalks, soaked with fat or pitch, were used for the same purpose. Indoors, these smoky torches were replaced by animal fat moulded in hollowed stones or shells, moss or the pith of rushes being used as wick, in the same manner as practised among the Aleutians and Esquimaux at the present day.

These torches and simple lamps were afterwards superseded by candles, which at first consisted of strands of hemp or vegetable pith soaked in tallow, but later on were made by pulling or dipping.²

The candle sconces were of various kinds: wood, clay, bronze, or lead. A candleholder found in Crete and dating from the Mycenaean epoch, has a protecting plate like some old church candlesticks still in use, the candle being stuck on a pointed spike. If wanted for use out-of-doors, the candles were put in earthenware lanterns, provided with lateral openings which were probably covered over with pig's bladder. Lanterns of this pattern have been found in many places in Greece. The first mention of glass panes is met with about 400 A.D. in Isidorus,³ though they were probably in use at an earlier period.

¹ "Odyssey," 6, pp. 305-310.

² See later in this chapter, and also Scheithauer, "Die Fabrikation der Mineralöle," p. 248.

³ "Isidorus," 20, 10, 7; "Journ. f. Gasbel.," 1907, 1128.

No great progress was made in illumination during the Middle Ages. Pine torches were used in the country and candles in the towns, the rich having wax candles, and other classes those of tallow or lard. Church lighting was the cause of the great extension of the wax candle industry.

The enormous consumption of candles for church purposes may be gathered from the records which state that, previous to the Reformation, 25,750 lb. of wax candles were burned every year in the principal church at Wittenberg, and that the Church of St. John Lateran¹ had 174 candelabra holding 8730 candles, which were lit on all festivals; and all of these must have been wax candles, the regulations being very strict on this point ("Nulla lumina nisi cera adhibeantur . . . cera ex apibus parata"). This great consumption of candles gave rise to a very flourishing candle industry, which, however, was conducted with very primitive appliances. In addition to the drawing process, the moulding of candles was also known,² especially for the production of wax candles. The candles were thickened progressively by casting fresh wax round them as they cooled. The large thick candles were made by rolling out the wax and then lapping and rolling it round the wick. Moulds of a simple character were also used occasionally. The moulding process has been in use since the middle of the fifteenth century, the candles being of tallow at first and subsequently of wax. The Wax Chandlers' Company was established in England in 1484 for making wax candles.³

The candle industry exerted an influence on artistic handicrafts inasmuch as candelabra, some of them of high artistic value, were made. Marvellous specimens of this work have been preserved, for example the candelabra, from the time of Bishop Hezilon (1044-1055) in the cathedral at Hildesheim, and that of the Emperor Frederick Barbarossa in Aachen cathedral.

From the seventeenth century onward, pine-splint torches began to go out of use, whilst torch and candle lighting increased in favour; and at the present time, pine-splint torches are only used in remote mountain valleys, as described by Rosegger. Candle wicks were first made of twisted tow, and afterwards of cotton; and the wick remained sticking up in the middle of the candle, the combustion being slower than that of the candle material, so that they had to be "snuffed" at intervals, with snuffers, in order to keep the light burning brightly.

Goethe expressed his discontent with the trouble produced by this operation by lines, which, freely rendered, run as follows:—

What better proof of an inventor's might
Than candles make, sans snuffers, to burn bright.

It was not until the introduction of plaited wicks, impregnated with chemicals, that a uniform flame which would burn without

¹ "Journ. f. Gasbel," 1908, 347.

² Scheithauer, "Die Fabrikation der Mineralöle," pp. 243-4.

³ "Chemical Technology," p. 69.

snuffing could be obtained, wicks of this kind curling over and burning at the edge of the flame with the same regularity as the material of the candle. This advantage, however, was confined to candles made of wax, spermaceti and stearine—introduced by Chevreul in 1820—the tallow candles with plaited wicks still continuing to burn askew and gutter owing to the low melting-point of the tallow.

Up to the 'thirties of the last century, candlemaking continued to be a home industry, except for a few small factories; and it was not until later that the first large candle works—that of De Milly, at Paris—was founded on the instigation of Chevreul. About the same time paraffin was discovered by Reichenbach, who recognized it as an important material for candlemaking. In this branch its use has increased beyond any other material, including the ceresine obtained, especially in Austria, by refining ozokerite. Before technical improvements had enabled pure white paraffin to be produced, it was usually mixed with wax or stearine, the mixture being coloured and made into candles; but early in the 'sixties it was found practicable to dispense with these adjuncts and use paraffin in the uncoloured condition.

At the outset, soft paraffin was used for moulding candles in the Saxon-Thuringian industry, as is still done for inferior grades of candles in the Scottish industry. Moreover, a thinner kind of candle was made at first, this naturally tending to bend and run. These circumstances which constituted a serious error were to blame for the paraffin candle being estimated below its deserts in its original homeland. Through the instigation of C. A. Riebeck, however, hard paraffin alone has been used for candlemaking since the end of the 'sixties. The high importance of candlemaking to the mineral oil industry of Saxon Thuringia can be gathered from the statistics given in Chapter XII.

Apart from the good raw materials, stearine and paraffin, the improved wicks and careful preparation have contributed to furnish satisfactorily burning candles such as are now put on the market by the industry in question. Paraffin and composite candles, made from imported paraffin, are also produced by a number of small makers in other parts of Germany.

The Raw Materials.

(a) *The Candle Material.*—The larger proportion of the paraffin produced in the lignite-tar industry is marketed, not as such, but in the form of candles; and for most of the works, the manufacture of candles is merely a means for providing an outlet for the raw material, paraffin. It is not every kind of paraffin that is suitable for making into candles in the condition in which it is produced. On the one hand, the paraffin candle must be of sufficiently high melting-point to keep it from bending in the warm; and it is only a portion of the total paraffin made that has the requisite melting-point of over 53° C. ($127\frac{1}{2}^{\circ}$ F.) for that purpose. A considerable proportion melts at a lower temperature, and must be mixed with either a harder paraffin or a considerable amount of stearine to give it a suitable degree of firmness. The candles made from this

latter material are known as "composite" candles, for which a paraffin of lower melting-point (about 48° to 52° C.) can be used—or even lower when the percentage of stearine is large.

Soft paraffin, as already mentioned, can have its melting-point raised by an addition of hard paraffin; and the melting-point of the mixture can be calculated from the quantities and melting-points of the components taken. Thus, for instance, a mixture of equal parts of paraffins melting at 55° and 49° C. respectively, will have the melting-point 52°. Candles of perfectly pure paraffin are seldom put on the market, owing to the tendency of the pure material to stick in the moulds when cold. This defect can be remedied by the addition of $\frac{1}{2}$ to 2 per cent of stearine. Only when cooling water of very low temperature is available, can paraffin candles be made without any stearine or with less than the proportion mentioned above.

Petroleum paraffins, which are now produced in large quantities in the manufacture of lubricating oils, are also used in candlemaking. These paraffins, however, are far more liable than lignite-tar paraffin to bend in the warm; and in order to obtain the same degree of firmness, it is necessary either to use a paraffin of higher melting-point, or else increase the proportion of stearine.

The commercial varieties of paraffin candles have about the following melting-points:—

1. Paraffin candles melting at 52° to 53° C. (125 $\frac{3}{4}$ ° to 127 $\frac{1}{4}$ ° F.)
2. Brilliant candles „ „ 53° to 54° C. (127 $\frac{5}{8}$ ° to 129 $\frac{1}{2}$ ° F.)
3. Crystal candles „ „ „ above 54° C.
4. Composite candles, made of paraffin melting at about 50° C. (122° F.).

Paraffin candles are more transparent in appearance than composite candles, which are more milk-white, like pure stearine candles.

Some of the candles are also coloured, especially those intended for export or for Christmas trees.

The material next in importance, though not produced in the industry itself, is stearine, a mixture of stearic acid, palmitic acid, and a little oleic acid, prepared by the dissociation of fats. The fats, consisting of fatty acids and glycerine, are decomposed into their components by a saponification process which need not be detailed, the fatty acids being then purified by pressure and distillation, and the more solid constituents, stearic acid and palmitic acid, are put on the market as stearine. A certain proportion of oleic acid, which is liquid, is always present and lowers the melting-point of the stearine. Only the better qualities, melting at about 50° to 55° C. (122° to 131° F.), are used for making paraffin and composite candles. The grades with low melting-points are high in oleic acid, and vice versa, many of the most fusible containing 25 to 30 per cent of oleic acid, whereas the firmer kinds have only 2 to 3 per cent. In addition to lowering the melting-point and softening the stearine, oleic acid has the defect of readily turning rancid and imparting an unpleasant smell to the candles, especially during storage. Moreover, in consequence of its avidity for oxygen (being an unsaturated compound), it has a bleaching effect on

any colouring matters added to the candles. For these reasons, the selection of suitable stearine, low in oleic acid, is a most important point in controlling the raw materials.

The illuminating power of a candle is greater in proportion as it contains more paraffin and less stearine, since the oxygen in this stearine constitutes nothing but ballast and is of no value to the illuminating power. Weight for weight, paraffin candles give about half as much again light as stearine candles, composite candles occupying an intermediate position according to the proportion of stearine they contain.

It should also be mentioned that mixtures of stearine and paraffin have always a lower melting-point than their components, the reduction following Raoult's law of congelation in a fairly regular manner, as has been shown by the author¹ (Fig. 61). The maximum reduction is about 6° to 9° C., according to the kind of stearine and paraffin used; and is produced when the materials are mixed in approximately equal amounts.

In spite of this low melting-point, however, mixtures of stearine and paraffin are always better able to stand the influence of warmth than pure paraffin. This is the true reason for adding stearine, the whiteness of colour being merely a secondary consideration. Misconception exists on this point in some quarters, the colour

being regarded as the principal thing, and attempts being made to obtain whiteness by replacing the expensive stearine by cheaper substitutes or such (though this is little needed) as make the material white and opaque. Substances that have been proposed for this purpose include: alcohol, β -naphthol, vaseline oil, and a whole series of other organic products. All of them, however, have certain defects, apart from the main drawback that they do not make the candles any firmer. Thus, alcohol evaporates during storage, β -naphthol has a strong smell and causes the candles to become discoloured after a short time, whilst vaseline oil makes the candles feel greasy and stains the packing material. Recently, it has also been proposed to employ refined mineral wax or the anilide or amide of stearic acid as substitutes for stearine, for, whilst these substances are dearer than stearine itself, only a very small quantity is needed to whiten the candles. This was considered a useful move as it falsifies certain melting-point tests based on the cloudy or opaque appearance of the

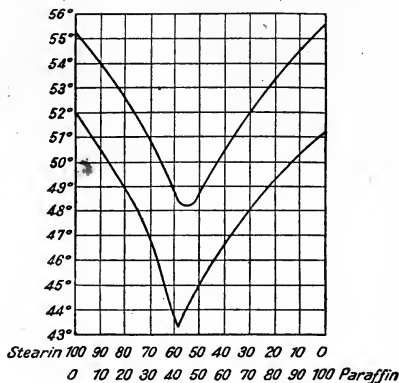

FIG. 61.

¹Gräfe, "Braunkohle," 1904, No. 9, p. 111.

material on solidification, and makes the melting-point seem higher than it really is. The reason for this fictitious appearance is that the added materials crystallize out when the paraffin cools, and produce the impression that the whole mass has solidified: whereas, in reality, the apparently solid mass is in a pulp until just above the melting-point of the paraffin, and the latter can still be forced out by pressure. The author¹ carefully investigated the matter some years back, and at the present time, candles made of such materials are rarely found in commerce.

(b) *The Wick.*—A well-made wick is an important feature in candles. The wicks used at present are almost exclusively made of plaited cotton yarn, though wicks of artificial silk or twisted paper have been tried experimentally, but abandoned as unsuitable. The weight of the wick should always bear a certain relation to that of the candle; if too thin, the wick is unable to absorb the melting material of the candle and the latter begins to run, whilst if the wick be too thick the flame smokes. The right proportion is about 0.35 to 0.45 per cent of the weight of the candle. The number of threads in the wick is not particularly important, for a wick plaited from a few strands of coarse yarn may burn just as well as one made of a number of slender threads, provided its weight be proportionate to that of the candle. Wicks of round section are now rarely met with, the general shape being flat and containing three to four strands, each consisting of several threads. The advantage of flat wicks is that they bend over in burning and are consumed at the edge of the flame, the former troublesome snuffing being thus rendered superfluous.

The yarn composing the wicks may be either bleached or grey, the former being generally used for thin or transparent (paraffin) candles, the colour of which would be rendered unsightly by grey wicks; but these latter may be employed for composite or stearine candles. The wick cannot be used direct for candlemaking in the form in which it comes from the plaiting machine. In some cases the threads are too tightly twisted, and in many instances the fresh wicks bend over more rapidly than when they project from the edge of the flame, curling up in a spiral and causing the candle to smoke and gutter. Experience shows that such wicks answer quite well when they have been kept for some time before use, the threads having lost their tension. Moreover, every wick has to be prepared by treating it with chemicals, such as ammonium phosphate, ammonium sulphate, boric acid, sal ammoniac, calcium chloride, saltpetre, borax, ammonium nitrate, etc.

It is a good plan to treat the wicks with about $\frac{1}{2}$ per cent of sulphuric acid at first, then immersing them in a 1 to 2 per cent solution of the chemical agent, with which they are boiled for some time, and are finally centrifugalized, or pressed, and dried. The object of the preparatory treatment is as follows:—

The ammonium salts prevent the wick from burning away too

¹“Chem.-Ztg.,” 1904, No. 95.

quickly; and as the wick is consumed, the residual phosphoric acid and boric acid fuse together into a bead, which takes up the small amount of ash left by the wick, and prevents this from falling into the hollow at the top of the candle. If this were not done, the ash would form a crust on the wick and act as an auxiliary wick, absorbing the candle material too freely and causing the candle to gutter or smoke. One defect of the wick is that, when the candle is first lighted, it takes some time to burn down far enough to reach the candle material, and on this account a fresh candle always takes a certain time to light up properly. Attempts have been made to remedy this defect, in some cases by slightly widening the bore in the plunger of the candle machine, so that the end of the wick could be surrounded by a thin film of candle material; or, as in English Patent No. 3438 of 1905, by dipping the wick end in a solution of celluloid, which increases the inflammability of the wick. In practice, however, this invention does not seem to have made headway.

The prepared and dried wicks are wound into balls or on rollers, any defects in manufacture being then detected and remedied. The balls or rolls are stored in a dry place, the wick yarn being fairly hygroscopic and capable of absorbing over 5 per cent of moisture from the air—a circumstance that, naturally, has no favourable influence on the burning qualities of the wick.

(c) *The Colouring Matters.*—In addition to the actual candle materials, paraffin, stearine, and wick, various colouring matters, mostly organic, are employed. Formerly, use was also made of inorganic pigment, such as Schweinfurt green, vermilion, chrome yellow, and others. Of these inorganic pigments, verdigris (copper acetate) alone is still used to some extent; but even this is mostly replaced by aniline dyes. The presence of verdigris is revealed by the coppery tinge of the end of the burnt wick, as can often be seen in Christmas tree candles.

Formerly, in addition to inorganic pigments, organic colouring matters of vegetable origin were employed; but these also have been replaced by the more suitable aniline dyestuffs. Most of the organic colouring matters belong to the triphenylmethane series and the phthalins, for example: victoria blue, methyl violet, brilliant green, and malachite green, rhodamine 6G and rhodamine 6B. Quinolin yellow, which is very fast to light, is generally used for yellow. The chief property required of the colouring matter is that it shall be fast to light and not become discoloured during storage, this latter point being if anything more important than the former, since the candles are not exposed to direct sunlight except in rare instances, whereas on the other hand it not infrequently happens that they have to be stored for a year or more, and in these circumstances it is highly essential that the colour should not fade more than slightly if at all. Bleaching in storage is not always the fault of the colouring matters, but in many cases is also due to the character of the stearine used, such as is rich in oleic acid being, as already mentioned, specially harmful in this respect. Green is the colour most liable to fade, and the one that needs most

care in the selection of the colouring matter and stearine. The evil cannot, however, be prevented entirely. For these reasons, a stearine of high melting-point and low oleic acid content, and whose properties have been tested beforehand, is preferably used for green candles. Some commercial makes of coloured candles are not coloured right through, but have a white core surrounded by a coloured shell. These are made by dipping white candles into a bath of coloured candle material and taking them out again quickly. The transfer pictures and other decorations with which many candles are embellished are applied after the candles have been moulded.

The quantity of colouring matter generally used for staining the candle material is small, amounting to only a few parts per thousand. The dye-stuffs are either dissolved in stearine and added to the paraffin—since pure paraffin has a very small direct solvent capacity for these substances (e.g. Soudan red)—or else an alcoholic, or similar solution of the colouring matters is stirred into the stearine, and then into the paraffin. Even these small quantities of colouring matter, however, are sufficient to affect the burning of the candles, plain candles always burning better than coloured ones. Attempts have also been made to perfume candles, by means of scents with an agreeable smell or such as give off disinfectant vapours when the candles are burning. Candles of this kind, however, are rarely met with—at all events they are not made on a large scale in any of the large works.

The Manufacture.

(a) *The Moulding Process.*—The course of operations in candle-making will now be briefly described. Formerly, when candles were chiefly made of wax and tallow, they were produced by dipping the wick repeatedly into the candle material, which was allowed to set after each immersion, thus gradually accumulating a number of layers round the wick until the required thickness and length were attained. When, however, the introduction of the new materials, stearine and paraffin, raised candlemaking to a large industry, this method of procedure proved no longer sufficient. At first the candles were cast in sheet-iron moulds, which were in turn replaced by cast moulds of fusible metal. These moulds were used singly at first, each being provided with a charging funnel; but improvements in the plant led to the assemblage of a number of separate moulds in a frame, provided with a charging hopper or trough and fitted with a special device for ejecting the candles. A machine of this kind is represented diagrammatically, in Fig. 62. The mould is traversed by a plunger, mounted on a tubular carrier. When the plunger is at its lowest position, it closes the mould, so that the liquid candle material can be poured in.

The material is then cooled down to setting point by the action of water, and when the candles are set, the plunger is forced upward, pushing the candle before it, the latter being gripped by the clamps at the top of the machines, as shown in the figure. The plunger being then lowered again, the mould is ready for another pouring.

The wicks are housed in a box under the machine and containing the rollers or tins for the balls. Each wick is passed through the plunger carrier and through a bore in the plunger, the flow of candle material through the latter being prevented by a rubber washer. This rubber is sufficiently elastic to allow the wick to slide past it, whilst pressing tightly enough against the wall of the bore to prevent the passage of any candle material.

The candle from the previous pouring, being held overhead by the clamp, keeps the wick truly centred in the mould—a point of some importance to the proper burning of the candle. The forcing up of the plunger takes some considerable power, and since a candle machine contains 100 to 400 moulds, the power must be applied by step-down gearing or by a worm.

The moulds themselves are made of a mixture of tin and lead, containing a little bismuth and antimony, and are cast on a highly polished mandrel, so that their interior surface may be perfectly smooth. It is of importance that the alloy should not be attacked by the candle material, since moulds that are rough inside make the candles very difficult to eject. Attempts have been made to introduce other materials for the moulds, such as glass, and more recently of porcelain. Unfortunately, moulds of this kind, though they are perfectly smooth inside and turn out fine candles with a shining surface, cannot be made so uniform in size as to be fitted into the usual candle machine without forcing; and they also taper sometimes towards the upper end so that the candles cannot be ejected. The introduction of such moulds of uniform measurements would be a great improvement, if it were possible, since porcelain is naturally endowed with a high power of resisting chemical agencies. On the other hand, metal moulds have the advantage that they can be melted down and made up again when worn out, whereas worn or broken porcelain moulds are almost useless. In a new type of candle machine, the moulds are not supported directly by the machine, but are inserted into brass or copper tubes in same, thus saving material, labour, and cooling water.

The moulding of candles in the machine is carried on in the following manner: the paraffin produced in the tar

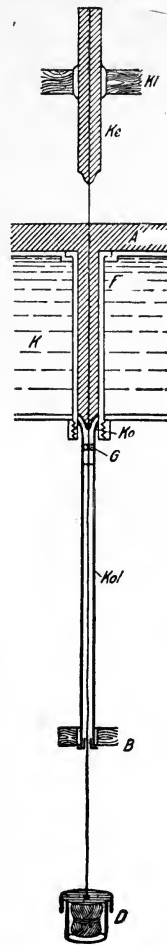

FIG. 62.—Candle Machine.

(Kl = Clamp. Ke = Candle. A = Top. F = Mould. K = Cooling water. Ko = Plunger. G = Rubber washer. Kol = Plunger carrier. B = Movable rail for plunger carriers. D = Wick.)

works is sent in a liquid form to the candle works, whilst bought paraffin, which is in the solid state, has to be melted. This is performed nearly always by direct steam in wooden vats, the condensed water being drawn off before the paraffin is poured into the moulds. Receptacles in which materials containing stearine are kept for any length of time are made partly of earthenware and partly of tin, these being found to wear best; but as a general rule the prolonged storage of such material in the molten condition is avoided, owing to its liability to discoloration.

Before pouring, the material has to be clarified by the addition of a little oxalic acid or aluminium sulphate. The object of this treatment is to remove salts of lime (originating in the water) which would otherwise combine with the stearine and affect the burning of the candles. With such salts aluminium sulphate forms a precipitate of very finely divided alumina, which carries any mechanical impurities down with it. The salts formed by the reaction are drawn off along with the water.

The moulder fills a can (fitted with one or two spouts) with the candle material, and takes it to the machine, though some works have successfully adopted the practice of feeding the molten material direct to the machine through pipes. This is chiefly done with candle material low in stearine; but it would also pay to experiment in the same way with material that is rich in stearine, in which case it would be necessary to use pipes capable of standing the action of stearic acid, namely a suitable ceramic material or resistant metal. To prevent the candle material from solidifying in the pipes, the latter are adapted to be heated, the simplest way being to enclose them in a leaden or copper steam jacket pipe. Before the candle material is poured into the machine, it is stirred up again, to prevent the heavier stearine from accumulating at the bottom of the can—that is to say if it is only added to the paraffin just before use, since, once thoroughly incorporated, the two cannot separate, the mixture being then comparable to a solution.

Before pouring the material into the machine, the latter must be warmed up by admitting steam into the jacket surrounding the moulds. If this were not done, but the candle material were poured into the cold machine, it would begin to set at once against the cold sides of the moulds, and consequently, any air bubbles carried into the moulds would be prevented from escaping, and the candles would have an unsightly pitted appearance. In all cases rather more candle material must be poured in than is required to fill the moulds, so that a layer nearly an inch deep remains in the trough. This is necessary for the following reasons:—

In its liquid state the candle material is specifically much lighter than when solid, and therefore contracts, in setting, to an extent that has been ascertained by the author to amount to about 11 to 14 per cent. If only just enough material to fill the moulds were poured in, cavities would be formed in the interior of the candles, and might even render them useless; but when an excess of material is present in the

trough, it can run down into the moulds under the force of suction exerted by the candles in setting. When the machine has been charged, warm water, from a previous operation, is run through the jackets to start cooling down the moulds, the complete cooling being afterwards effected with cold water. In a quarter to three-quarters of an hour, according to the thickness of the candles, the material will be cool enough for the ejection of the candles from the moulds.

The wicks of the candles still left from the previous operation in the clamps or sleeves are cut off with a triangular knife, the clamps are tilted up and the candles removed. After clearing out the surplus material in the feed trough, the clamps are lowered, and the candles are ejected from the moulds by winding up the plunger rail, the candles coming within the sphere of action of the clamps.

By turning an eccentric lever, the clamps are caused to grip the candles firmly, being lined with plush in order to prevent the candles from being crushed by the pressure. The plunger rail is lowered to bring the plungers back into their lowest position, thus tightening and centring the wicks, the upper ends of which are, as it were, anchored in the candles held by the clamps. This done, the machine is ready for pouring again.

According to the size of the machine, 100 to 400 candles are produced at each pouring; and in America, for instance, machines turning out 800 candles at a time have been made. Such large machines may be suitable where labour is dear, but otherwise they cannot be recommended, being difficult to supervise and awkward to get at in the event of repairs, such as the replacement of moulds, plungers, plunger rails, etc. It is not feasible to group all sizes of moulds so as to permit of machine moulding, large altar candles, for instance, being preferably moulded singly, otherwise the machines would be too gigantic. Machines of this kind have been constructed, but are so large as to extend through nearly two stories in the factory.

Special attention should be bestowed on thorough cooling. It has been found that, with protracted cooling, candle material rich in stearine is liable to segregation, the portions cooling first containing more stearine than the rest. Moreover, when proper cooling is provided, the candles are more easily ejected from the moulds, the finish being then higher and the requisite motive power less. Many works suffer considerably from the great difficulty experienced in procuring sufficient cooling water; and for this reason, refrigerating machinery has been successfully installed for artificially cooling the water. Otherwise it is necessary, in the summer months, to increase the proportion of stearine, as the paraffin candles stick obstinately in the machine—and this, of course, means increased cost of production, owing to the difference in price between the two materials. If even this remedy fails, the candles must either be tapped individually with a wooden mallet, to loosen them in the moulds, or else, if this does not answer, they must be melted out by admitting steam to the jackets. In this latter event, the next batch will be wasted, since the wicks will be out of centre. An

important point in facilitating the ejection of the candles from the moulds is the careful regulation of the pouring temperature, which should be between 65° and 75° C. (150° to 165° F.). In some works, one special tally mould (making a candle with some special mark, such as a ring at the base) is provided on each machine. Each tally represents a pouring, and the total number handed in at the close of the day's work shows how many candles have been made, the payment being based on piece-work.

Various shapes of candle are made, some being plain, others fluted; and in addition there is the self-fitting pattern, with a taper base enabling the candle to fit better into the holder. This type of candle is more popular in England than in Germany. Sizes are still more varied than shapes, ranging from 2 lb. each to about 150 to the lb.; but very small sizes are made by cutting longer candles into short lengths.

(b) *Finishing*.—On leaving the machine the candles are not ready for sending out, but have to be finished. In the first place the base is butted, i.e. trimmed off level with a knife. This is necessary because, in ejecting the candles from the machine, the wicks are forced out of centre at the base while the candles are still soft, thus spoiling the appearance. This lowest extremity has to be trimmed off, a larger quantity being sometimes removed at the same time, namely when a definite weight of candle is required and no suitable moulds for producing it are available. Sometimes as much as half the candle has to be cut away, which of course is very wasteful, both in labour and material, since the colour of the latter is always impaired by remelting. The butting process is effected by hand or machine. The candles are placed in a kind of trough, the lower end of which is provided with an adjustable board, set according to the length of candle desired; and all the ends projecting from the trough are then cut off by a sharp knife with a sliding cut. Endeavours have been made to perform the butting process in the moulding machine, by pushing up the plungers so that the portion of candle to be removed protrudes from the top edge of the mould. Numerous devices and cutters have been tried for this purpose, but without any complete practical success, the cutters always breaking small pieces out of the edge of the candles, owing to the cut not being sufficiently oblique. Thick candles are tapered a little by trimming them at the base, so that they will fit in the holders better. This is done with a high-speed rotary cutter, similar to a pencil-sharpening machine, and either driven by an engine or coupled direct to the shaft of an electromotor. As a rule, paraffin and composite candles do not require polishing to increase their gloss; but in many works stearine candles are polished by passing them through mechanically operated woollen cloths. Candles are sometimes, though rarely provided with a stamped impression, to indicate that they belong to a certain owner, and thus prevent theft. Such impression is produced by pressing the candle against a steam-heated brass block, bearing the name either engraved or in relief. Under this treatment a

certain quantity of the candle material is melted away, and the weight is reduced in comparison with the unstamped candles.

(c) *Packing the Candles.*—The next stage is packing in cardboard cases, of which there are three sizes, weighing respectively about 9, 13½, and 18 oz. gross, to contain ½, ¾, and 1 lb. net. The candles are wrapped in tissue paper and placed in the boxes, which are labelled with pictures (for Christmas candles, etc.), some fancy name for the candles, or the name of the maker or retailer. In some cases the candles are put direct into wooden cases without any wrapper. The cardboard boxes are either made by female labour or purchased ready made.

The wooden cases are frequently made in the works by mechanical appliances, including circular saws and nailing machines, and printing machines for impressing the quality marks on the box ends. For over-sea transport or long distances inland, the contents of the cases are first wrapped in oiled cloth, the outside of the case being strengthened with hoop iron.

(d) *Working up Candle Waste.*—In most candle works there is a department for working up the manufacturing waste, such as candle material that has been spilled on the floor or left in the storage and melting vessels; material that has been kept too long, etc. These are treated separately from the butt trimmings and the cleanings from the trough of the candle machine, both of which are simply melted down and used again, being nearly as colourless and good as the pure material. The other scraps first named are melted down and boiled with a little acid, the mechanical impurities they contain settling down more readily in consequence of this treatment. The treated mass is brownish in colour, due to dirt, colouring matters and salts of iron resulting from the contact of the candle material with the iron fittings of the machines or iron floor plates in the works. Next follows boiling with caustic soda, which removes the stearine, the resulting soap carrying with it most of the colouring ingredients, whilst the majority of the organic dye-stuffs are destroyed by this treatment. The residue, consisting of pure paraffin, has always a yellowish cast, mainly because the very permanent quinolin yellow has not been eliminated; but after being treated with animal charcoal, in the same manner as crude paraffin, it is sufficiently decolorized to be used over again for candlemaking. The stearine soap from the soda treatment is decomposed with sulphuric acid and deposits a brown stearine, containing a little paraffin and suitable for many purposes of the chemical industry. The quantity is not very large, being only about 0·1 per cent of the weight of candles produced, so that its disposal does not present any difficulties.

CHAPTER X.

CHEMICAL COMPOSITION OF THE TARS AND THEIR DISTILLATES.

A. LIGNITE TAR.

LIGNITE tar is formed during the dry distillation of lignite, various constituents of the latter being concerned in the process of formation, such as the cellulose left during the incomplete carbonization of the coal, the humic acids and the bitumen or mineral wax. All three components have been investigated in connection with the part they play in the formation of the tar; and it has been found that the most valuable constituents of the tar, namely the paraffin and other saturated hydrocarbons, are mainly furnished by the mineral wax. Acid bodies of phenol character are chiefly formed from the products of the transformation of cellulose to coal, whilst the humic acids furnish substances of varying characteristics, chief among which, apparently, are the so-called neutral bodies. Whether and to what extent the ash constituents of the lignite have any effect on the quality of the tar has not yet been decided, though from the results of laboratory experiments it may be regarded as probable that the alkaline earth constituents (salts?) of the ash abstract carbon dioxide from the acids of the mineral wax and the humic acids. Thus, for example, when pure mineral wax is distilled by itself it furnishes an entirely different product from that obtained by distilling the same wax in presence of a little lime. In the former case the distillate still contains an appreciable quantity of acid products, and gelatinizes to a stiff pulp when treated with alkalis; whereas the distillate obtained when lime is used remains liquid and is almost entirely free from acid products.

A subordinate part is played by the nitrogenous constituents in the tar, which only contains about $\frac{1}{4}$ to $\frac{1}{2}$ per cent of same. It would be an advantage if the small amount of nitrogen (about 0.3 per cent) in lignite could be more completely utilized for the production of technically valuable products, such as ammonia, or pyridin bases for instance. According to the researches of Wohman, only about 10 per cent of the nitrogen contained in lignite is at present found again in the tar, another 12 per cent being in the tar water, 66 per cent in the coke, and 12 per cent in the gas.

The percentage proportion of these distillation products in lignite tar depends both on the kind of coal and the method of carrying out the distillation. The higher the retort temperature, the richer will the tar be in carbon and the poorer in hydrogen, that is to say the richer in unsaturated hydrocarbons and aromatic compounds, and the greater the proportion passing away in the gases.

So far as the saturated hydrocarbons are concerned, the products of distillation contain an unbroken series of them, from methane up to the highest members of the methane series, containing thirty and more carbon atoms in the molecule. The lower members of the series are chiefly found in the retort gas, and the higher ones—about from hexane onward—in the tar. By subjecting the retort gas to very low temperatures, the vaporous hydrocarbons—commencing approximately with propane—can be condensed, and then isolated, to some extent, by fractional vaporization. To obtain the saturated hydrocarbons of lignite tar, the basic constituents are first eliminated by agitation with dilute acid, the phenols being next removed by the aid of alkali, and finally the unsaturated compounds by repeated agitation with concentrated sulphuric acid. This latter treatment, however, is not altogether free from objection, because, on the one hand, a certain portion of the unsaturated compounds and also of the aromatic hydrocarbons escape the reaction, whilst on the other hand, the saturated hydrocarbons are attacked in the warm. This is evident from the fact that sulphur dioxide is liberated, which product can only arise through the oxidation of hydrogen, the temperature being insufficient for the oxidation of carbon, and there being no corresponding liberation of carbon dioxide. The acid treatment is followed by a thorough washing with water and dilute carbonate of soda solution, the residual liquid being warmed along with picric acid to remove the greater portion of the aromatic hydrocarbons which escaped the sulphuric acid treatment. The lower members of the remaining hydrocarbons form a colourless liquid of not unpleasant smell, whilst the higher members form a transparent white mass, known under the generic name of paraffin, and consisting in reality of a mixture of various paraffins. The solid paraffin comprises the hydrocarbons containing seventeen to thirty-two atoms of carbon. The unsaturated hydrocarbons in lignite tar belong to various series, including the ethylene and acetylene series, and probably others still poorer in hydrogen. Up to the present no one has succeeded in isolating these bodies in a pure state. It is, however, possible to recover the products obtained on agitating the tar distillates with sulphuric acid, by diluting the spent acid with water and boiling it repeatedly. This treatment gives a black liquid, smelling of peppermint and capable of being refined by fractionation; but it must not be assumed that we have here to deal with the unsaturated hydrocarbons in the original form in which they were present in the lignite tar, since both oxidation and polymerization have been set up by the sulphuric acid. At all events, the hydrocarbons recovered in this way are in the

highest degree unsaturated, this being indicated by their energetic reaction with sulphuric acid, their high iodine value (extending above 100) and their powerful reaction with potassium permanganate, in presence of which substance they become strongly heated, the mass even spurting out of the test vessel. The oxidation is accompanied by the formation of acids which, however, have not yet been more closely investigated. When liberated by treating their salts with an acid, they give off a repulsive smell, recalling capronic, caprylic, or capric acid.

The refined paraffin itself is not entirely free from unsaturated hydrocarbons, as is evident from the fact that it always exhibits an iodine value, though but a low one (about 2 to 5 according to the degree to which the paraffin has been refined). As a rule a tar will be so much the better in quality in proportion as the content of unsaturated hydrocarbons is lower; and for some purposes their presence is injurious. Thus, for example, the lignite-tar oils that are rich in unsaturated compounds and poor in hydrogen, burn with a much smokier flame than the petroleum oils which are rich in hydrogen; and at the same time they require a particularly abundant supply of air to the burner.

The unsaturated hydrocarbons are also of little value in the production of oil gas, since they furnish much tar and little gas; and also on account of their low hydrogen content. They are less troublesome for use in motors, the only drawback being that their low hydrogen content lessens the calorific power of the oil. Whether they are injurious in paraffin has not yet been ascertained; and it is even open to surmise that the high stability of the lignite-tar paraffins in comparison with the petroleum paraffins is due in part to the unsaturated hydrocarbons. As shown by the experiments of Sabatier and Senderens, and more recently Erdmann, the unsaturated hydrocarbons can be constrained to combine with hydrogen and become saturated. This transformation is accomplished by passing the vaporized hydrocarbons, in association with hydrogen, over a contact substance, e.g. finely divided nickel. It would be highly useful if this method could be employed to improve the lignite-tar products on a technical scale; but the prospects of success do not appear very high at present, chiefly because the sulphur products—which will be referred to later—invalidate the activity of the contact substance within a short time.

Aromatic hydrocarbons also are present in lignite tar. They originate chiefly in secondary decompositions of hydrocarbons of the fatty series through contact with the hot lining and iron fittings of the retorts. The amount of these, however, is relatively small, the chief representative being naphthalene, which is principally found in the most volatile fractions of the lignite tar, e.g. the solar oil, in which it occurs to the extent of about 1 to 2 per cent. It is isolated by warming the oil along with picric acid, and allowing the resulting picrate to crystallize out in the cold. The crystals are aspirated, and washed with

volatile benzine (from petroleum) the dried precipitate being transferred to a flask and heated to boiling along with a little dilute caustic soda, whereupon the naphthalene distils over and deposits in the condenser tube. The naphthalene, although it does not affect the burning of the oil, makes itself unpleasantly apparent in many of the uses to which the oil is put. Thus, in employing lignite-tar oil for washing hydrochloric acid gas in order to eliminate the compounds of chlorine with arsenic, it has been found that the apparatus occasionally becomes choked up with hexachlorbenzol, formed by the chlorination and decomposition of the naphthalene, the chloride of arsenic apparently acting as a carrier of chlorine. Other aromatic hydrocarbons, such as benzol derivatives, have only been discovered in small proportions in lignite tar. Larger quantities of complex aromatic hydrocarbons are formed towards the end of the tar-distilling process. Solid red-brown masses are deposited in the condenser worm, these consisting chiefly of picene and chrysene. It must, however, be assumed that these substances were not originally present in the tar, but have been formed by the decomposition of the tar vapours through contact with the heated sides of the retort. The picene can be recovered in a comparatively pure state by washing the crude picene with benzine and then recrystallizing it from pyridin or cumol. It separates out in the form of white crystals melting at about 340° C. Up to the present no use has been found for this substance.

In addition to the true aromatic hydrocarbons, the tar contains hydromatic hydrocarbons, similar to the naphthenes obtained from Russian petroleum; but the quantity is small. One series of aromatic hydrocarbons is present to a large extent (10 to 15 per cent) in lignite tar, namely the phenols, which, however, are undesirable since they have to be got rid of at considerable expense for chemicals (caustic soda). They are of high specific gravity and on this account their presence in tars rich in creosote is easily detected. To effect their isolation the tar or tar distillate is agitated with dilute caustic soda, the solution being drawn off and extracted repeatedly with benzine or ether until the solvent drains away almost colourless. The object of this treatment is to remove the so-called neutral oils (see later) which are partially soluble in the soda tar. The purified soda tar is next decomposed with dilute sulphuric or hydrochloric acid, the deposited creosotes being drawn off, dried by heating above 100° C., and then fractionated. They consist mainly of creosotes. The initial member of the phenol series, viz. carboic acid, is only present to a small extent in the tar, from which it was isolated by Rosenthal. The recovered creosotes are impure, containing still a considerable proportion of sulphuric-acid compounds of an acid character. Whether the sulphur here takes the place of oxygen, or in what way it enters the molecule, has not yet been ascertained. In any event the content of sulphur compounds cannot be small, since the sulphur content alone is about 1 to 2 per cent, indicating from 5 to 10 per cent of such

compounds. Moreover, the sulphur cannot be eliminated by treating the creosote with reagents ordinarily capable of dissociating sulphur from combination, the creosotes being still found to contain sulphur after repeated distillations over litharge. These sulphur compounds are probably the cause of the disagreeable smell which has hitherto prevented the lignite-tar creosotes from being used for medicinal purposes. When freshly distilled, the creosotes form a colourless, highly refractive oil, but they soon become dark coloured on exposure to the air. They seem also to contain polyvalent phenols, derivatives of which, guaiacol for instance, have already been identified therein. The occurrence of phenols is also probable, since they have likewise been isolated from the tar water. Thus, pyrocatechin can be obtained by treating the tar water—especially when concentrated—with lead acetate; and Rosenthal has recovered large quantities in this way. The origin of the creosotes of high boiling-point (up to 400° C.) in this tar has not yet been ascertained. When freshly distilled, they form dark-brown viscous oils.

As already mentioned, a portion of the nitrogen in the tar is distilled over, some of it also appearing as ammonia in the tar water. The nitrogenous constituents of the tar consist chiefly of pyridin and its homologues. Pyridin is readily soluble in water, and it therefore appears both in the tar water and in the tar, the amount of pyridin bases in the latter being about $\frac{1}{2}$ per cent. These bases were formerly recovered in practice, and were employed for purifying anthracene and denaturing spirit. The regulations in respect of such denaturing bases have, however, been made more stringent, almost complete volatility at 140° C., and solubility in water, being insisted upon; but since the bases recovered from lignite tar have a higher boiling-point, and are only partially soluble in water, their recovery has been abandoned, and they are allowed to escape, as sulphates, in the effluent.

Quinolin has also been isolated from the tar, together with aniline, but in merely insignificant quantities. Nitriles are also present, and are revealed by the circumstance that when many of the oils are distilled over caustic soda, ammonia is given off from the decomposition of nitriles, in spite of the oils having been previously acidified so that no free ammonia can be present.

Larger quantities of bases are found in other distillation tars, for example in those of the Scottish industry, which are obtained from the more nitrogenous shales. These bases also belong, for the most part, to the lower members of the pyridin series, and pass into the ammonia liquor in consequence of their solubility in water. These pyridin bases are to be recovered on a manufacturing scale in the industry in question.

The sulphur compounds play an important, though undesired, part in lignite tar. They originate in the organic sulphur compounds in the lignite, both the mineral wax, the humic acids, and the cellulose substance containing sulphur. The double sulphide of iron (Markasite)

frequently present in coal is not to blame for this sulphur, since even coal with ash practically free from iron will yield tars containing sulphur. The proportion of sulphur in the tar is about $\frac{1}{2}$ to $1\frac{1}{2}$ per cent, and in spite of the numerous methods proposed, it has not yet been found practical to eliminate it in practice. Thus, treating the tar with concentrated (and even fuming) sulphuric acid, aluminium chloride, copper sulphate, and sodium has been proposed, but none of these methods has found practical application.

The quantity of the sulphur compounds cannot be small, since the sulphur forms only a fraction in the molecule of such compounds and amounts to at least 5 per cent. Only a few such compounds have been actually isolated.

The best known of the sulphur compounds is sulphuretted hydrogen, the presence of which is apparent both in the retort gases and in those from the distillation of the tar. Carbon disulphide is found in the first runnings of the tar, but the amount is only small, as is also that of the thiophene, the presence of which was detected by Erdmann. On agitation with mercuric chloride solution, the tar oils give a white precipitate, indicating the presence of mercaptans, to which is no doubt due the bad smell of the lignite tar and its distillation products.

On agitating the tar with concentrated caustic soda, as is practised for removing the creosotes, another class of substances pass into solution, namely the so-called neutral oils, the nature of which is still unknown. They are isolated by allowing the soda tar (obtained by acting on the tar oils, with caustic soda of 38° density) to stand for several days, the deposited oil being syphoned off so long as it continues to settle down. The soda tar is then diluted with a large quantity of water, whereupon it separates into two layers: an upper one of oil, and a lower one consisting of dissolved creosote tar. The oil is removed, agitated several times with dilute soda lye, and then fractionated. This treatment furnishes a strongly refractive oil, of high specific gravity, peculiar smell, and darkening quickly in the air. The oil contains oxygen and also sulphur, but is not soluble in alkali and therefore cannot be an acid or a phenol. It reacts powerfully with oxidizing agents, especially permanganate, with formation of acids the nature of which has already been described. Possibly we have here to do with ketones, but up to the present this product has not been closely investigated. The presence of oxygen is indicated by the low calorific value of the oil, which is below 10,000 cal.

According to Erdmann,¹ the following substances are contained in lignite tar:—

¹ "Die Chemie der Braunkohle" ("Chemistry of Lignite"), pp. 92 *et seq.*

CONSTITUENTS OF LIGNITE TAR.

1. *Hydrocarbons of the Paraffin Series.*

	Formula.	Melting-point °C.	Boiling-point (760 mm.).
Heptane ¹	C ₇ H ₁₆	—	98°
Normal Nonane ²	C ₉ H ₂₀	—51°	149,5°
Normal Decane ³	C ₁₀ H ₂₂	—30 to 32°	173°
Undecane ³	C ₁₁ H ₂₄	—26,5°	194,5°
Heptadecane ⁴	C ₁₇ H ₃₆	22,5°	303°
Octadecane ⁴	C ₁₈ H ₃₈	28°	307°
Nonadecane ⁴	C ₁₉ H ₄₀	32°	330°
			at 15 mm.
Eicosane ⁴	C ₂₀ H ₄₂	36,7°	205°
Heneicosane ⁴	C ₂₁ H ₄₄	40,4°	215°
Docosane ⁴	C ₂₂ H ₄₆	44,4°	224,5°
Tricosane ⁴	C ₂₃ H ₄₈	47,7°	234°

2. *Hydrocarbons of the Ethylene Series.*

Decylene ⁵	C ₁₀ H ₂₀	—	—
---------------------------------	---------------------------------	---	---

3. *Aromatic Hydrocarbons.*

Benzol ⁶	C ₆ H ₆	6,4°	80,4°
Toluol ⁷	C ₆ H ₅ (CH ₃)	—93°	111°
m-Xylol ⁸	C ₆ H ₄ (CH ₃) ₂	—54 to —53°	139,2°
Mesitylene ⁹	C ₆ H ₃ (CH ₃) ₃	—	163°
Naphthalene ¹⁰	C ₁₀ H ₈	80°	218°
Chrysene ¹¹	C ₁₈ H ₁₂	250°	448°
Picene ¹²	C ₂₂ H ₁₄	350°	518 bis 520°
Hydrocarbon ¹³	C ₁₆ H ₁₈	117°	300 bis 303°

4. *Naphthenes in Small Quantity.*¹⁴¹ Rosenthal, "Zeitschr. f. angew. Chemie," 1893, 109.² Heusler, "Berichte d. Deutsch. chem. Ges.," 25, 1665 [1892]; Oehler, "Zeitschr. f. angew. Chemie," 1899, 561.³ Oehler, "Zeitschr. f. angew. Chemie," 1899, 561.⁴ Krafft, "Berichte," 21, 2256 [1888]; 29, 1323 [1896].⁵ Heusler, "Berichte," 28, 500 [1895].⁶ Heusler, "Berichte," 25, 1672 [1892]; Rosenthal, "Zeitschr. f. angew. Chemie," 1893, 108; Krey, *ibid.* 109.⁷ Heusler, "Berichte," 25, 1673 [1892]; Oehler, "Zeitschr. f. angew. Chemie," 1899, 561.⁸ Heusler, "Berichte," 25, 1674 [1892]; Oehler, "Zeitschr. f. angew. Chemie," 1899, 561.⁹ Heusler, "Berichte," 25, 1674.¹⁰ Heusler, "Berichte," 25, 1677; Oehler, "Zeitschr. f. angew. Chemie," 1899, 562.¹¹ Adler, "Berichte," 12, 1889 [1879].¹² Burg, "Berichte," 13, 1834 [1880]; Boyen, "Chem.-Ztg.," 1889, 29, 64, 93.¹³ Oehler, "Zeitschr. f. angew. Chemie," 1899, 563.¹⁴ Heusler, "Berichte," 28, 488 [1895].

5. Bases.

	Formula.	Boiling-point.
Pyridin ¹	C ₅ H ₅ N	114,5°
α-Picolin ²	C ₅ H ₄ (CH ₃)N	129°
β-Picolin ³	C ₅ H ₄ (CH ₃)N	143 to 144°
γ-Picolin ⁴	C ₅ H ₄ (CH ₃)N	ca. 145°
2, 6-Dimethylpyridin ⁵ (Lutidin)	C ₅ H ₃ (CH ₃) ₂ N	142 to 144°
3, 4-Dimethylpyridin ⁶	C ₅ H ₃ (CH ₃) ₂ N	162 to 164°
2, 4-Dimethylpyridin ⁷	C ₅ H ₃ (CH ₃) ₂ N	150°
2, 5-Dimethylpyridin ⁷	C ₅ H ₃ (CH ₃) ₂ N	154°
2, 4, 7-Trimethylpyridin ⁸ (Collidin)	C ₅ H ₂ (CH ₃) ₃ N	170 to 171°
Quinolin ⁹	C ₈ H ₇ N	238°
Anilin ¹⁰	C ₆ H ₅ (NH ₂)	184,5°
Nitriles ¹¹	—	—

6. Oxygen Compounds.

Homologues of Acetone ¹²	—	—
Phenol ¹³	C ₆ H ₅ (OH)	180 to 180,5°
o-Cresol ¹⁴	C ₆ H ₄ (CH ₃)OH	190,8°
m-Cresol ¹⁴	C ₆ H ₄ (CH ₃)OH	202,8°
p-Cresol ¹⁴	C ₆ H ₄ (CH ₃)OH	201,8°
Guaiacol ¹⁵	OH · C ₆ H ₄ · OCH ₃	205,1°
Creosol ¹⁶	CH ₃ O · C ₆ H ₃ (CH ₃)OH	221 to 222°

7. Sulphur Compounds.

Carbon disulphide ¹⁷	CS ₂	46°
Thiophene ¹⁸	C ₄ H ₄ S	84°

¹ Rosenthal, "Jahresbericht des Techniker-Vereins der sächs.-thür. Mineralölindustrie," 1890-91, 7; "Chem.-Ztg.," 14, 870.

² Krey, "Berichte," 28, 106 [1895]; Frese, "Zeitschr. f. angew. Chemie," 1903, 12; Rosenthal, *Ibid.*, 1903, 221; Ihlder, *Ibid.*, 1904, 524.

³ Krey, "Berichte," 28, 106; Ihlder, "Braunkohle," 3, 59, [1904].

⁴ Ihlder, "Braunkohle," 3, 60 [1904].

⁵ Ihlder, "Braunkohle," 3, 59 [1904].

⁶ Ihlder, "Zeitschr. f. angew. Chemie," 1904, 1670.

⁷ Ihlder, "Braunkohle," 3, 60 [1904]; "Zeitschr. f. angew. Chemie," 1904, 524.

⁸ Krey, "Berichte," 28, 106 [1895]; Ihlder, "Braunkohle," 3, 61 [1904]; "Zeitschr. f. angew. Chemie," 1904, 525.

⁹ Döbner, "Berichte," 28, 106 [1895].

¹⁰ Oehler, "Zeitschr. f. angew. Chemie," 1899, 562.

¹¹ Heusler, "Berichte," 28, 438 [1895].

¹² Heusler, "Berichte," 28, 496 [1895].

¹³ Rosenthal, "Jahresbericht des Techniker-Vereins der sächs.-thür. Mineralölindustrie," 1890-91, 6; "Zeitschr. f. angew. Chemie," 1892, 402.

¹⁴ Riehm, Ger. Pat. Nr. 53,307.

¹⁵ Vehrigs, see Scheithauer, "Fabrikation der Mineralöle," 1895, 222.

¹⁶ v. Boyen, "Chem.-Ztg.," 1889, 357.

¹⁷ Rosenthal, "Zeitschr. f. angew. Chemie," 1893, 109.

¹⁸ Heusler, "Berichte," 28, 493 [1895].

B. SHALE TAR (CRUDE OIL).

Scottish shale tar is of approximately the same composition as lignite tar, except that—as already mentioned—its content of nitrogenous bodies is higher. The tar consists of saturated and unsaturated hydrocarbons, and also contains aromatic compounds and small quantities of naphthenes.

Aromatic hydrocarbons¹ were seldom present in the tars produced in the old retorts used in the 'seventies, the retort temperature being low. On the other hand the tars from the modern retorts, in which decompositions are set up by the high temperatures used, always contain benzols. Thus, for example, Broxburn naphtha (sp. gr. 0.735) has been found to contain, in the fraction boiling between 130° and 165° F., 2.6 per cent of benzol; and in that boiling between 212° and 221° F., 2.5 per cent. of toluol. Naphthalene, methyl-tetra-methylene, pentamethylene, and hexamethylene have been obtained in varying quantities from the corresponding tar fractions.² Picene and chrysene have also been detected.³ Phenols and cresols are likewise constituents of shale.⁴

In addition, pyridin and quinolin bases are present. Robinson and Goodwin⁵ have identified the quinolin bases, and Garret and Smythe⁶ the members of the pyridin series. Naphtha contains 1½ per cent of pyridin bases. Sulphur compounds, detected by their odour of garlic, are also present in shale tar.

F. Heusler⁷ found, in the fractions below 131° F., from Scottish shale tar: 42 per cent of paraffin, 10 per cent of naphthalene, 7.3 per cent of aromatic hydrocarbons, and 39 per cent of olefines.

¹ "The Oil Shales of the Lothians," p. 184.

² R. Steuart, "J. Soc. Chem. Ind.," **19**, 986.

³ "The Oil Shales of the Lothians," p. 183.

⁴ T. Gray investigated the phenols in naphtha, "Journ. Soc. Chem. Ind.," **21**, 845.

⁵ Trans. Roy. Soc. Edin., **28**, 561; **29**, 265 and 273.

⁶ Trans. Chem. Soc., 1902, 1903.

⁷ "The Oil Shales of the Lothians," p. 185.

CHAPTER XI.

THE LABORATORY WORK.

BEFORE the economic situation rendered the intensive utilization of all the products compulsory, laboratory work in the distillation-tar industry was neglected; but at the present time it has grown into an essential feature.

Almost every works in which distillation tars are treated, is fitted with a well-equipped laboratory which has to discharge a variety of functions. One of its tasks is to improve the quality and quantity of the tar by selecting suitable raw material; another being to check the intermediate and final products made in the works, so as to ensure uniform quality and satisfy the requirements of customers. Finally, by selecting the reagents to be purchased, the buying department is assisted.

An essential portion of the laboratory work is to devise new processes, since competition obliges the manufacturer to simplify his methods of working either by saving expense in labour and material or by improving the final products. In this connection, of course, no definite rules can be laid down, since the problems to be solved are not uniform in character, and the whole work lies more within the sphere of invention. In the main, however, the problems to be solved are:—

Increasing the yield of tar by protecting the bitumen during the distillation process.

Simplifying the treatment of the tar, avoiding the use of expensive chemicals wherever possible.

Refining the paraffin cheaply and at the same time improving the quality.

It is easier to lay down instructions for the work of the laboratory, in which the operations are practically the same, day after day. For the most part the checking of the raw materials and final products is in the hands of skilled laboratory assistants, of course under the supervision of a chemist.

TESTING THE RAW MATERIALS.

The first point to be considered is the testing of the raw materials: the bituminous lignite and the fire coal. Perhaps even more important than the actual testing is the sampling, it being particularly diffi-

cult to obtain a true representative sample in view of the fluctuating composition of the material, and the large quantities involved. The best method is to take a shovelful from the middle and side of a truck load when being unloaded, this being repeated with as many trucks as possible, and the samples thus obtained mixed together. The 1 to 2 cwt. of sample material is crushed small, arranged in a square heap, and divided into quarters by two diagonal lines (see Fig. 63).

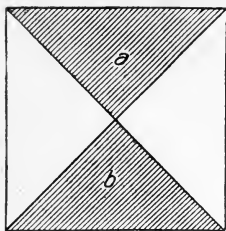

FIG. 63.

Two of the opposite triangular portions are then mixed together, arranged in a square and quartered as before and the series of operations being repeated until there are only 100 to 200 gm. of the sample left. This is packed in a tightly closed tin and sent to the laboratory. Glass jars or tins may be used; but there is no need to solder the latter up, especially if the laboratory is not very far away. If one wishes to be extra cautious a strip of rubber

or the like may be secured round the edge of the cover.

In the laboratory the sample is reduced to powder and tested to determine the water and ash content, behaviour under dry distillation, the calorific value, distillation products, and percentage of bitumen. Any one or more of these may of course be omitted, according to local circumstances.

The percentage of water is determined by heating 10 gm. of the sample in a drying oven, at a temperature of 105° to 110° C. until the weight is constant. For very accurate determinations this drying should be performed *in vacuo* or in a current of inert gas, e.g. carbon dioxide, since lignite oxidises readily in the air and gives off carbon dioxide in addition to absorbing oxygen.

The most important estimation in the case of the bituminous lignite is the yield of tar. The apparatus used for this purpose is sketched in Fig. 64, and consists of a retort holding about 200 c.c. and a glass

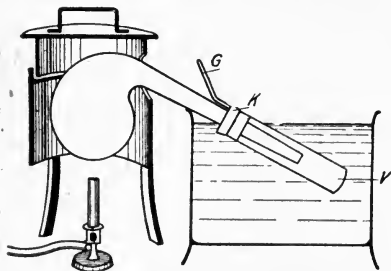

FIG. 64.—Apparatus for estimating the yield of tar from bituminous lignite.

(G = Gas effluent. K = Cork. V = Receiver.)

receiver into which the neck of the retort fits by means of a cork traversed by a small tube for the escape of the gases liberated during distillation. The retort must be of refractory glass or it would fuse at the high temperature used; and it is preferably sheltered from external cooling influences by a jacket and cover of sheet metal or asbestos. The receiver is immersed in water

to cause the fullest possible condensation of the tar vapours, a very small loss making a considerable difference in view of the minute quantities

used. About 20 to 50 grm. of the bituminous lignite in its natural condition of moisture are placed in the retort, the neck of the vessel being carefully cleaned out after charging. The retort is heated up by a small, smoky flame at the start, the heat being increased after half an hour; and after maintaining the maximum of heat for one hour, the flame is finally lowered again. The whole treatment lasts four to six hours, more rapid working being undesirable since it lessens the yield of tar and increases the losses due to the production of gas.

Retort and receiver are weighed before the distillation, to ascertain:—

Weight of empty retort,	
" " retort charged with lignite,	
" " empty receiver,	
" " receiver after distillation,	
" " retorts " "	

When distillation is completed the contents of the receiver will be found to consist of two strata—water and tar. Should any tar remain in the neck of the retort, it is rendered fluid by warming it with the lamp, and is transferred to the receiver. It being difficult to separate the drops of tar from the water, the following method is pursued: after the receiver and contents have been weighed it is filled nearly to the top with hot water, which causes the tar to melt and run together; whereupon the whole is placed in a vessel with cold water or ice, thus causing the liquid tar to solidify as a cake. This cake is taken out, dried with filter paper and weighed.

The difference between the tars of the retort and the weight of the retort after distillation, gives the yield of coke. The amount of the tar water is found by subtracting the weight of the cake of tar and that of the empty receiver from the weight of the receiver after the distillation. Finally, any difference remaining between the original weight of substance and the sum of the coke, tar, and tar water, represents the loss by gasification. The values obtained by analysis cannot be directly applied to work conducted on the large scale, owing to the far higher losses by decomposition sustained in the latter case, the retorts being far more leaky than a glass still and allowing tar vapours to escape outwards and air inwards. In both contingencies there is a loss, due to the combustion of the tar vapours, amounting to 30 to 40 per cent, so that only about 60 to 70 per cent of the tar is actually recovered in practice.

If for any reason dry lignite comes forward for distillation, the results obtained must be referred to the same material in the condition of moisture in which it leaves the pit, namely with a content of about 50 to 55 per cent of moisture.

Seeing that the practical yield differs from that in the laboratory by reason of the greater losses sustained in the former case, there is no object in subjecting the tar recovered in the glass receiver to analysis—which would, moreover, be difficult in view of the small quantity available.

If it be desired to test the tar as well, a larger trial distillation must be performed with the raw material (lignite or shale) so as to obtain at least 100 grm. of tar. Even this tar, however, is not comparable with that produced in the works, though more nearly approximating thereto than is the tar obtained in glass retorts.

The tar water may also be examined, this being advisable when one is employing some new material in which a high percentage of nitrogen is suspected. The water is tested to see whether it has an acid or alkaline reaction. Geologically recent materials like peat and some lignites yield acid tar waters in consequence of decomposition of the cellulose; whereas older materials, old lignite (brown coal), coal and bituminous shale yield alkaline tar waters. The test is of course merely qualitative. If it be desired to ascertain the percentage of nitrogen precisely, in order to form an opinion on the probable yield of ammonia, the nitrogen determination must be performed directly with the raw material, preferably by the Kjeldahl method.

Information on the quality of bituminous lignite is also afforded by the determination of the bitumen content; since the higher the percentage of bitumen, the better the yield and quality of the tar, as a rule. The term bitumen here applies to the substances that can be extracted from lignite by solvents. What is stated here in respect of lignite is not, however, unconditionally applicable to bituminous shales, since Scottish shale though yielding 20 to 50 per cent of tar does not contain any constituents that will dissolve in organic solvents.

The determination of bitumen in lignite is preferably effected with dry material, since the solvents—benzol especially—used for extraction will permeate the dry material more easily. Any extraction apparatus may be used, such as that of Soxhlet, or the one constructed by Gräfe (Fig. 65). Ten grm. of the dried substance are placed in a filter paper cylinder and covered with cotton wool, the reflux condenser being arranged so that the condensed solvent trickles down through the cartridge. The extraction flask is charged with 100 to 200 c.c. of benzol, a few small stones or fragments of earthenware being put in to prevent bumping while boiling. The benzol is then raised to boiling point and retained at that temperature for two hours, whereupon the contents of the flask—now stained

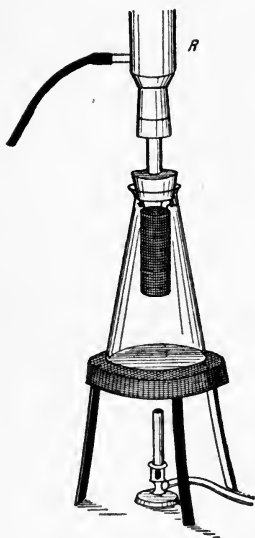

FIG. 65.—Gräfe's extraction apparatus for the determination of bitumen in lignite.

(R = Reflux condenser.)

brown by the dissolved bitumen—are poured into a weighed dish, which is heated on the water bath to expel the solvent. The final traces are very difficult to eliminate, and it is therefore advisable to heat the

dish up to about 150° C. over the bare flame previous to weighing, the dish and contents being weighed after cooling. Good lignite contains about 10 to 20 per cent of bitumen, referred to the dry substance. The determination of bitumen is particularly important in the case of lignites intended for the extraction of that substance, a process that is now being carried on in a number of works specially erected for the purpose. The bitumen is a blackish brown, brittle mass melting at 80° to 85° C. (176° to 185° F.), and extensively used for the manufacture of phonograph cylinders and shoe polishes. The testing of bitumen will be dealt with later.

TESTING THE TARS AND OTHER DISTILLATION PRODUCTS.

The chief object in testing the tar is to ascertain how much paraffin it contains, this latter being the most valuable constituent. An approximate idea can be gathered from the specific gravity and the solidification point. As a rule, the lighter the tar the higher the paraffin content, and vice versa. The specific gravity, however, is increased not only by relative absence of paraffin, but also by the presence of creosote—a constituent of low value and difficult to get rid of. In this respect also, specifically light tars are to be preferred.

The specific gravity determinations must be effected in the warm, the tar being solid at the ordinary temperature. The tars now treated have the specific gravity 0.880 to 0.900, though these limits are occasionally exceeded to a slight extent in either direction. As already mentioned, a high solidification point of the tar is a sign that it is rich in paraffin; but the indication is not infallible, many producer tars, for instance, containing still undecomposed bitumen and consequently exhibiting a high specific gravity though their paraffin content is low. Good lignite tar solidifies at 20° to 30° C. (68° to 86° F.).

The only way to obtain a correct view of the quality of a tar is by distillation, followed by the chemical examination of the products. About 300 gm. of tar are distilled in a glass flask or small metal retort, the tar being warmed gently at first, particularly if it contains water, since it is then liable to froth over. The products are collected in tared glass beakers. If the tar vapours be condensed by the aid of water, care must be taken either to stop the supply of water when paraffin appears in the distillate, or else to use warmed water at this stage, since otherwise the condenser will get choked up with solid paraffin. Distillation is conducted at such a rate that 3 to 4 drops issue from the condenser per second. When a drop of the distillate solidifies on being brought into contact with a lump of ice, paraffin is indicated and the receiver is changed. The first distillate that does not contain paraffin is known as crude oil. Sufficient of the paraffin distillate is driven over to make, in association with the crude oil, 93 per cent of the original tar, the residue being classed as "red product" and coke.

When the tar is very crude, and especially if it contain solid impurities such as coal dust, the distillate will not reach the 93 per cent

The ash content is ascertained by incinerating 1 grm. of the coke in a crucible. Over-violent incandescence should be avoided, since otherwise a portion of the carbonic acid in the carbonates of the ash may be driven off and the results brought down below the truth.

The calorific power can be tested by direct combustion of the coke in the bomb calorimeter, or else calculated with a fair amount of accuracy by the formula:—

$$\frac{8140 (100 - a - w) - 600 w}{100}$$

in which *a* represents the ash content, and *w* the percentage of moisture in the coke, since when properly made this coke is practically nothing but carbon and ash constituents, the water having been introduced in the quenching process.

If the coke should burn badly, the reason may be ascertained by determining the saline matter it contains. Coke containing salt burns badly, owing to the fact that the particles of salt are fused by the heat and form a kind of glaze over the coke, which is thus prevented from burning. The salt is already present in the lignite, and little can be done to counteract the evil, the best remedy being to leach the coke with water.

The retort gas, most of which is utilized for heating the retorts, can be tested for its calorific value in the Junker calorimeter or the small portable calorimeter constructed by the author;¹ or the same may be calculated, by the usual formulæ, from the analytical composition of the gas. When the gas is required for driving gas engines, the percentage of sulphuretted hydrogen must also be determined—qualitatively with lead-acetate paper after the gas has been purified, and quantitatively by titrating the crude gas with iodine solution and thiosulphate.

The tar water contains about 0.1 per cent of nitrogen, the amount being ascertained by acidifying a large volume of the liquid, concentrating this down to small bulk and treating it with caustic soda to liberate the ammonia, which is collected in normal hydrochloric acid. The quantity of the ammonia is found by titrating the acid back with normal alkali.²

TESTING THE TAR OILS.

In the course of working up the distillation tars, the various distillation products, the reagents, etc., used, such as sulphuric acid, caustic soda, and animal charcoal, and the paraffin produced, all have to be tested.

With regard to the examination of the oils and paraffin masses, reference may be made to what has already been given in connection with testing the tar, at least so far as the most important determinations—

¹Dr. E. Gräfe, "Laboratoriumsbuch für die Braunkohlenteerindustrie" ("Laboratory Book for the Lignite-tar Industry"), p. 49.

²l.c. p. 54.

creosote and paraffin—are concerned. In the case of the oils, the specific gravity, fractional analysis, flashing-point, viscosity, solidifying-point, sulphur content, and calorific value have to be determined.

The specific gravity is determined by means of the aræometers used in the mineral oil industry. It should be remembered that the specific gravity of the oils is lower in the warm, and therefore all determinations should be carried out at a standard temperature (15° or 20° C. according to specification), or calculated thereto, an allowance of 6 to 8 units in the fourth decimal place being made for each 1° C.

The fractional analysis is performed in the Engler apparatus as generally employed in the petroleum industry. 100 c.c. are taken for the analysis, and the fractions are measured at intervals of 50° C. The distillation should be carried on at such a rate that 1 to 2 drops of distillate fall from the end of the condenser per second. The operation is not continued beyond 300° C., as decomposition then sets in. In the case of oils containing paraffin, the temperature at which paraffin makes its appearance is determined by placing a drop of the distillate on ice. If this solidification point be above 300° C., the thermometer is first taken out of the flask, which is then closed with the simple cork only.

The flashing-point is determined in one of the usual forms of testing apparatus, the Abel tester being used for oils of low flashing-point, and the Pensky apparatus, or a porcelain basin, for the oils of high flashing-point.

It is also necessary to test the viscosity of the oils. This is not important in itself, all the lignite-tar oils being too fluid to be suitable for direct use as lubricating oils; but some of the higher fractions are employed for mixing with such oils. The chief object of the test is to prevent oils with a viscosity exceeding 2.6 from being sent out, owing to the higher rate of freight charged on German railways. The Engler viscosimeter is generally used; and its method of application needs no special mention here. In the Scottish shale-oil industry, the Redwood viscosimeter is used.

The solidification point is determined by immersing a thermometer in a sample of oil contained in a test glass, which in turn is placed in a refrigerating mixture, from which it is taken at intervals and tilted to see whether the oil is still fluid. This test is chiefly applied to the oils intended to be mixed with lubricating oils, for which purpose an unduly high solidification point is undesirable. These oils generally solidify at -5° to -10° C.

The sulphur content is ascertained by burning the oil in a flask charged with oxygen, the products of combustion being absorbed by a solution of sodium peroxide (Fig. 68). The determination is chiefly of informative value, because sulphur plays a certain part in the lignite

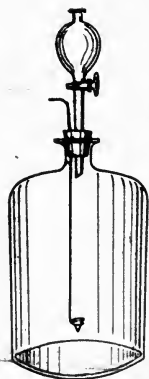

FIG. 68.—Flask for ascertaining the sulphur content.

The ash content is ascertained by incinerating 1 grm. of the coke in a crucible. Over-violent incandescence should be avoided, since otherwise a portion of the carbonic acid in the carbonates of the ash may be driven off and the results brought down below the truth.

The calorific power can be tested by direct combustion of the coke in the bomb calorimeter, or else calculated with a fair amount of accuracy by the formula:—

$$\frac{8140 (100 - a - w) - 600 w}{100}$$

in which *a* represents the ash content, and *w* the percentage of moisture in the coke, since when properly made this coke is practically nothing but carbon and ash constituents, the water having been introduced in the quenching process.

If the coke should burn badly, the reason may be ascertained by determining the saline matter it contains. Coke containing salt burns badly, owing to the fact that the particles of salt are fused by the heat and form a kind of glaze over the coke, which is thus prevented from burning. The salt is already present in the lignite, and little can be done to counteract the evil, the best remedy being to leach the coke with water.

The retort gas, most of which is utilized for heating the retorts, can be tested for its calorific value in the Junker calorimeter or the small portable calorimeter constructed by the author;¹ or the same may be calculated, by the usual formulæ, from the analytical composition of the gas. When the gas is required for driving gas engines, the percentage of sulphuretted hydrogen must also be determined—qualitatively with lead-acetate paper after the gas has been purified, and quantitatively by titrating the crude gas with iodine solution and thiosulphate.

The tar water contains about 0.1 per cent of nitrogen, the amount being ascertained by acidifying a large volume of the liquid, concentrating this down to small bulk and treating it with caustic soda to liberate the ammonia, which is collected in normal hydrochloric acid. The quantity of the ammonia is found by titrating the acid back with normal alkali.²

TESTING THE TAR OILS.

In the course of working up the distillation tars, the various distillation products, the reagents, etc., used, such as sulphuric acid, caustic soda, and animal charcoal, and the paraffin produced, all have to be tested.

With regard to the examination of the oils and paraffin masses, reference may be made to what has already been given in connection with testing the tar, at least so far as the most important determinations—

¹Dr. E. Gräfe, "Laboratoriumsbuch für die Braunkohlenteerindustrie" ("Laboratory Book for the Lignite-tar Industry"), p. 49.

²l.c. p. 54.

creosote and paraffin—are concerned. In the case of the oils, the specific gravity, fractional analysis, flashing-point, viscosity, solidifying-point, sulphur content, and calorific value have to be determined.

The specific gravity is determined by means of the aræometers used in the mineral oil industry. It should be remembered that the specific gravity of the oils is lower in the warm, and therefore all determinations should be carried out at a standard temperature (15° or 20° C. according to specification), or calculated thereto, an allowance of 6 to 8 units in the fourth decimal place being made for each 1° C.

The fractional analysis is performed in the Engler apparatus as generally employed in the petroleum industry. 100 c.c. are taken for the analysis, and the fractions are measured at intervals of 50° C. The distillation should be carried on at such a rate that 1 to 2 drops of distillate fall from the end of the condenser per second. The operation is not continued beyond 300° C., as decomposition then sets in. In the case of oils containing paraffin, the temperature at which paraffin makes its appearance is determined by placing a drop of the distillate on ice. If this solidification point be above 300° C., the thermometer is first taken out of the flask, which is then closed with the simple cork only.

The flashing-point is determined in one of the usual forms of testing apparatus, the Abel tester being used for oils of low flashing-point, and the Pensky apparatus, or a porcelain basin, for the oils of high flashing-point.

It is also necessary to test the viscosity of the oils. This is not important in itself, all the lignite-tar oils being too fluid to be suitable for direct use as lubricating oils; but some of the higher fractions are employed for mixing with such oils. The chief object of the test is to prevent oils with a viscosity exceeding 2.6 from being sent out, owing to the higher rate of freight charged on German railways. The Engler viscosimeter is generally used; and its method of application needs no special mention here. In the Scottish shale-oil industry, the Redwood viscosimeter is used.

The solidification point is determined by immersing a thermometer in a sample of oil contained in a test glass, which in turn is placed in a refrigerating mixture, from which it is taken at intervals and tilted to see whether the oil is still fluid. This test is chiefly applied to the oils intended to be mixed with lubricating oils, for which purpose an unduly high solidification point is undesirable. These oils generally solidify at -5° to -10° C.

The sulphur content is ascertained by burning the oil in a flask charged with oxygen, the products of combustion being absorbed by a solution of sodium peroxide (Fig. 68). The determination is chiefly of informative value, because sulphur plays a certain part in the lignite

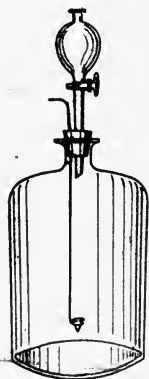

FIG. 68.—Flask for ascertaining the sulphur content.

tars, which part cannot be influenced in the course of manufacture. As a rule, oils low in sulphur are preferred for gas oils, there being then less trouble in refining; but, on the other hand, the sulphur-content of the oils is practically immaterial so far as the gas is concerned, since nearly all the sulphur products either pass into the tar or are removed in the refinery. The method of determining the sulphur content is described in detail in Gräfe's book on laboratory work in the lignite-tar industry (p. 6).¹ Lignite tars contain about 0.5 to 1.5 per cent of sulphur in the form of organic compounds.

The calorific value of the oils is an important feature, since it determines their suitability for use in the Diesel engine. Some information is also afforded as to their utility as gas oils, those rich in hydrogen having a higher calorific value than such as are low in that constituent; and, according to modern views, such oils are better adapted for the production of oil gas and for carburetting water gas. Nevertheless, this property does not increase in strict proportion to the hydrogen content. A distinction must be drawn between maximum and minimum heating value, the former being also known as the combustion value. This maximum value is based on the combustion of the oil, with simultaneous condensation of the water of combustion derived from the hydrogen content of the oil. The minimum heating value is based on the combustion of the oil, without condensation of the water of combustion; so that the two values differ by the heat of evaporation of the water of combustion. This difference amounts to about 7 per cent of the heat of combustion. The oils at present manufactured have a calorific value of 9800 to 10,000 calories, and a heat of combustion of 10,400 to 10,700 cal. Oils rich in oxygen, such as the creosote oils, do not attain these values, the heat of combustion being only about 9000 cal.

The examination of the paraffin masses is generally confined to the determination of the percentages of creosote and paraffin. The method in both cases has already been described in connection with testing the tar. An important point is the testing of the paraffin scale obtained by crystallizing and pressing the paraffin masses, this product being examined for its melting-point, paraffin content, percentage of water and dirt, and its suitability for refining.

The melting-point is determined either by the capillary-tube or rotary-thermometer methods already described; though, for very accurate testing, use is made of the Shukoff method described under the section on candlemaking. The paraffin content is ascertained by the Zaloziecki or Holde method (also previously described), except that, owing to the high percentage of paraffin, only 1 to 2 grm. of substance are taken.

The percentage of water² is determined either by heating the paraffin direct to about 150° C. in a flask, and then ascertaining the loss in

¹ See also, "Zeit. angew. Chemie," 1904, 610.

² The Scottish methods of testing paraffin scale are fully described in the author's work on "Mineral Oils".

weight; or else by allowing the melted paraffin to settle down for some time and then solidify, the cake of paraffin being lifted and the deposited water taken up with a tared filter paper and determined by weighing.

To ascertain the percentage of dirt,¹ the paraffin cake from the preceding test is remelted and filtered through a dry, tared filter, the adherent paraffin being finally washed off with hot benzol, and the filter weighed. When purchased scale of unknown properties is in question, a test must also be applied to see how it behaves in refining. The material is melted, treated with 15 per cent of benzine (such as is used in refining paraffin), and poured on to water, as small slabs, which are then wrapped in filter paper and filter cloth and pressed in a screw-down press. The pressed cakes are remelted, again mixed with benzine and treated as before. After the third repetition, the paraffin is freed from superfluous benzine by a jet of steam, and then treated with 2 per cent of decolorizing powder. After repeated filtration through filter paper, the refined material is moulded into slabs and compared with the paraffin usually made in the works. The yield of finished paraffin from crude scale treated in the above manner is about 60 to 75 per cent according to the melting-point of the material.

TESTING THE REAGENTS USED FOR REFINING THE OILS AND PARAFFIN.

Sulphuric acid and caustic soda are used in refining the oils. The caustic soda lye is prepared on the premises, drum soda being dissolved by the aid of steam. The strength of the sulphuric acid is tested by titration, or, more simply, by a specific gravity instrument. As a rule the arsenic in the acid does no harm and need not be specially estimated, unless the acid is to be used for other purposes, such as in soldering the leaden linings of agitators, etc. This welding process is performed with oxyhydrogen gas, and if the hydrogen for this purpose be generated from sulphuric acid and zinc, cases of arsenical poisoning (arseniuretted hydrogen) are always to be expected. Several cases of this kind have been attended with fatal results in this industry, and attention is therefore once again drawn to the fact that the sulphuric acid used should be free from arsenic; or the gas should be purchased in cylinders.

Another important point is that the sulphuric acid should be as free as possible from nitrous compounds, or it will be liable to corrode and destroy the leaden lining of the agitators.

The caustic soda is tested for its percentage purity. As a rule the manufacturers give a guarantee of the minimum percentage of free hydroxide, expressed in terms of carbonate of soda. Thus, a 125 per cent caustic soda means a soda which, if entirely converted into carbonate, would yield 125 per cent of that substance. This method of calculating is, however, useless in connection with the mineral oil industry, since the carbonate of soda has no action at all, being incapable of entering into combination with creosotes. Hence, in testing

¹ "Die Fabrikation der Mineralöle," pp. 206 *et seq.*

the caustic soda, the carbonate is precipitated by treating the normal solution of 40 gm. of caustic soda in 1 litre of water with 50 c.c. of a 10 per cent solution of barium chloride, the liquid being then made up to 1 litre and titrated with normal hydrochloric acid. Under this test, caustic soda designated as 125 per cent is generally found to contain 92 to 94 per cent of free hydroxide.

Benzine and decolorizing powder are used in refining paraffin. The benzine is usually produced on the premises; and, like the other oils is tested for boiling and flashing-points. The former is an important factor, as indicating whether the benzine can be easily eliminated from the paraffin by a jet of steam. A sample of benzine containing a large proportion of constituents of high boiling-point is either discarded for the purpose in view, or else is separated into high and low boiling fractions, since otherwise the paraffin cannot be obtained in a transparent and inodorous condition. An excessively low flashing-point must also be avoided, as increasing the fire risk in the pressing and melting processes. As a rule the fire risk of the benzine used for refining paraffin is not particularly high, the flashing-point being between 20° and 30° C. (68° and 86° F.).

The decolorizing powder usually consists of the residues from the manufacture of potassium ferrocyanide, and similar agents. The amount used is between 0.5 and 2 per cent of the weight of paraffin. Of late a large number of mineral decolorizing agents have also been placed on the market, and are also employed in the petroleum industry, such as the silicates and hydrosilicates of aluminium and magnesium (fullers' earth). The test applied is a practical one, partially refined, but not yet decolorized paraffin being intimately mixed with about 2 per cent of the material on the steam bath for a quarter of an hour, then filtered and cast into slabs, which are compared with those obtained in the works. The test, however, is not yet at an end, the slabs being left exposed to the light for several days because some of these decolorants of the fullers' earth class give a decolorized product which, though excellent in appearance for the moment, is not fast to light, but soon turns yellow or brown. For this reason the test for permanence of decoloration should never be omitted. The spent powder, whether a sample or that used in the works, should always be examined for the amount of paraffin it has retained, which must be recovered by a special process. The smaller the quantity of paraffin so retained the better, other circumstances being equal.

The test is performed in the following manner: 1 to 5 gm. of the spent powder are weighed out and treated in the extraction apparatus with a solvent of low boiling-point (e.g. ether, chloroform, carbon tetrachloride, or benzol), the extract being poured into a tared basin and the solvent expelled.

TESTING THE PARAFFIN.

The paraffin produced in the works is, to a large extent, made up into candles in factories attached to the premises, some portion, how-

ever, being sold. The tests applied relate to the colour, fastness to light, and the smell, for which, of course, no special method can be given, especially since experience plays a large part in appraising the article by these characteristics.

Apart from these, the principal test is that for the melting-point. At one time it was even more important than at present, paraffin then being sold on the basis of melting-point only, the price increasing or diminishing by approximately 6d. per lb. (1 mark per kilo.) for each difference of 1° C. in the melting-point above or below a fixed standard. As a general rule, it may still be considered that, other conditions being equal, a paraffin of high melting-point is worth more than one with a low melting-point. The methods¹ of determining the melting-point are too many to be enumerated here, and it will be sufficient to mention the one considered to be the best, and which is the most largely used in the paraffin industry, namely the Shukoff method, recommended by the Association for Testing Materials. This method is performed by placing 20 to 30 grm. of paraffin in a jacketed, and preferably evacuated, vessel (Fig. 69), a thermometer graduated to one-fifth of a degree being inserted. When the temperature has fallen to about 3° to 5° C. above the anticipated melting-point, the vessel is shaken up well until the contents become turbid, whereupon it is left to stand, the point at which the mercury filament in the thermometer remains stationary being the melting-point or solidification point of the paraffin. The rotary thermometer and capillary tube methods already described for the determination of melting-point may also be used as giving rapid, though less accurate results.

It is superfluous to apply any special test for ascertaining the amount of heavy oils present in paraffin, their presence being already indicated by lack of transparence (appearance of cloudy and milky flakes), the smell and low fastness to light. A direct determination, based on the difference in the paraffin determination by the Holde or Zaloziecki method does not give precise results, especially when the paraffin is of low melting-point, soft paraffins being always partially soluble in the precipitants. Provided a sample of paraffin exhibits sufficient transparence, permanence in colour, and absence of smell, it may be regarded as free from oil, especially when it does not exude oil and produce greasy patches on the wrapper, etc., during prolonged storage.



FIG. 69.—
Melting-
point
tester for
paraffin.

TESTS APPLIED IN CANDLE WORKS.

In the candle works the raw materials, paraffin, stearine, wick, and colouring matters, have first of all to be tested. A good deal of the preceding section has been devoted to the testing of paraffin, and all that now remains is the test for stability. For this, the melting-point

¹ Scheithauer, "Der Fabrikation der Mineralöle," pp. 208 *et seq.*

alone is no criterion, though it may be held as a general rule that the stability increases with the melting-point. Nevertheless, commercial brands of paraffin, though of high melting-point, occasionally fail to exhibit commensurate stability, the reason being that such paraffin consists of hydrocarbons of widely divergent melting-points, a condition which is found by experience to lessen the resistance to bending, a property that subsequently becomes unpleasantly manifest in the candles. The test for stability consists in pouring the paraffin into moulds of the size of candle to be made (generally $\frac{2}{3}$ to $\frac{3}{4}$ in. thick and 8 to 10 in. long), and after leaving them to cool down to uniform temperature for some time, fastening the candle in a horizontal position by a clamp at the base. In this position the test candle is exposed for an hour to a constant room temperature of 25° C. (77° F.). If it bends appreciably, the paraffin is unsuitable for being made into candles by itself, and must either be rendered suitable by mixing with it some harder paraffin, or else made up into composite candles with stearine.

Before using a batch of paraffin (especially a purchased article of unknown properties) for making candles, a sample candle is moulded and burned. Certain kinds of paraffin are found to burn badly, either guttering or smoking; but in many cases the blame must be laid, not on the paraffin alone, but on the combination with a certain wick. For example, a paraffin which burns badly as a paraffin candle, may burn excellently in admixture with others or as composite candles the wicks of which have been prepared in a different manner.

An important auxiliary in candlemaking is stearine, large quantities of which are used; on the one hand for making composite candles (which contain 25 to 33 per cent of this substance), and on the other as an adjunct (0.5 to 2 per cent) to paraffin candles to facilitate detaching the candles from the moulds. The stearine is not manufactured in lignite-tar works, but is purchased from the makers. The price being about double that of paraffin, special attention should be devoted to testing and valuing the material. There are two commercial varieties of stearine, one being produced by saponification, and the other by distillation. The former is of superior colour and smell, as well as in fastness to light, and is therefore of higher value. It contains less oleic acid than distilled stearine.

The melting-point of stearine is tested in the same manner as that of paraffin, by the Shukoff method. The lower the melting-point the higher the oleic acid content, though the determination of the melting-point does not give more than approximate information in this particular.

The exact percentage of oleic acid is determined by the iodine value (Hübl or Wijs method, the latter being the quicker). The performance of these methods may be considered as too well known to require description here. Multiplying the iodine value with 1.11 gives the percentage of oleic acid present in the stearine. Specimens rich in oleic acid are not looked on with favour for making composite candles, owing to the strong smell, which becomes more decided on storage.

Moreover, the colouring matters used in the candles fade more quickly when the amount of oleic acid is large. In the case of each new parcel of stearine, the precaution of making specimen candles and testing their burning qualities should on no account be omitted. Experience has shown that some kinds of stearine leave behind, in burning, a long skeleton in the wick, and this skeleton gradually extends down into the méniscus of the candle, acting like a second wick and causing it to gutter. The reason of this is that, owing to defects in manufacture or other causes, the stearine contains small quantities of lime, the presence of which can be detected by incinerating a large sample of the stearine. This, however, is a troublesome operation, and the practical method of testing the burning properties is simpler.

The candle wicks are purchased, though some works make them on the premises. In this case also, the practical test, by burning, is simpler and more decisive than analytical examination. Sometimes the question to be decided is whether a wick has been already prepared or not. In such case, about 8 to 12 in. of the wick are suspended from a needle, and a light is applied to the lower end, the wick being rapidly consumed. If it leaves merely a thin grey filament of ash, it has not been prepared, but if the residue is fairly thick, and black in colour, it may be assumed that the preparatory treatment has already been applied.

The last of the auxiliaries used in candlemaking is the colouring matter. At the present time organic colouring matters are used almost exclusively, though copper acetate is occasionally employed for green candles. The colouring matters are tested for their purity and fastness to light.

So far as purity is concerned, no apprehensions need exist on this point if the dye-stuffs have been purchased from makers of good repute. Occasionally, however, injurious admixtures are present, these originating in the manufacturing process and not being added for the purpose of adulteration. They are mostly inorganic salts, such as sodium chloride and sulphate, which have been used in salting out the dye-stuffs from solution. They may act adversely in two ways: if the dye-stuffs are added to the candle material direct, the salts interfere with the burning, the wicks being very sensitive to even small quantities of certain salts; on the other hand, if the dye-stuffs are first dissolved, the salts cause a stubborn retention of colouring matter in the residue. Some commercial dye-stuffs again contain large quantities of dextrin, added in order to reduce the colour to a certain strength. Dye-stuffs of this kind are naturally unsuitable for candlemaking. The percentage content of salts and dextrin is determined by extraction with alcohol or other suitable solvent, in an extraction apparatus, and by weighing the residue from this treatment.

The fastness to light is determined by colouring sample candles to the desired depth of shade and wrapping one half of the candle in opaque paper, the whole being then exposed to the light for several days or weeks. The uncovered portion will then be found to have

faded more or less, and comparison with the protected moiety will show how far the colouring matter is permanent.

The laboratory has also to discharge the further task of checking operations in the moulding shop, the chief being to test the melting-point of the finished candles, their burning properties and the stearine content. Owing to its high price, the amount of stearine is kept down as low as possible, though in composite candles this economy must not be pushed too far or the candles will be transparent. The stearic acid is determined by titration, 10 gm. of the candle material being melted with 50 to 100 c.c. of hot alcohol and titrated with alcoholic alkali, standardized so that 1 c.c. exactly corresponds to 0.1 gm. of stearine. If 10 gm. of material have been taken, the volume of alkali consumed will directly represent the percentage content of stearine. This standardized alkali contains 21.2 mg. of caustic potash per 1 c.c. The solution is prepared by dissolving 25 to 30 gm. of caustic potash in 50 c.c. of water, and making it up to 1 litre with 96 per cent alcohol. One gm. of the finely shredded stearine is weighed out on the chemical balance, and titrated with the alkali in presence of phenolphthalein until a red coloration is observed. If 9.7 c.c. of alkali are consumed, then 970 c.c. must be diluted to 1 litre in order to obtain the requisite strength. In testing candles of other makes it is occasionally desirable to make a further investigation of the stearine and paraffin, and also to ascertain the amount of light furnished by a given weight of candle material. This is done in the following manner:—

Ten gm. of the candle material are melted along with 25 c.c. of 96 per cent alcohol and 25 c.c. of water, and titrated to determine the stearine content, a few extra c.c. of alkali being added and the whole left to cool. The paraffin collects on the surface and solidifies, and is removed and washed in water. The residual red-tinged solution is diluted with water, then supersaturated with hydrochloric acid, and the deposited stearine is filtered off, repeatedly washed with water, re-melted and weighed. Its melting-point and iodine value can then be determined.

As a rule the origin of the paraffin has to be identified. The method adopted is to melt about 1 gm. of the paraffin along with about 1 c.c. of concentrated sulphuric acid, in a test glass, on the water bath. Under this treatment, petroleum paraffin will generally remain colourless, only a slight discoloration being produced in the acid at most, whereas lignite-tar paraffins turn yellow or brown.

To ascertain the quantity of light furnished by a given weight of candle material, a weighed portion of candle is lighted in the dark room, and the intensity of the light is compared about every ten minutes with a Hefner lamp or standard candle. At the end of one or two hours the quantity of candle material consumed is ascertained by weighing the remainder, and the intensity of illumination is calculated to 1 gm. of material.

Latterly, various stearine substitutes have been proposed for addi-

tion to the paraffin; but these, although producing the milk-white appearance of the composite candle, do not possess the increased stability in the warm forming the superiority of the composite over the paraffin candle. These adjuncts are, spirit, B-naphthol, and vaseline oil.

Candles made with the addition of spirit gradually part with that ingredient during storage, and become transparent again, on the outside at least. The amount of such volatile adjunct can be exactly determined by melting a small quantity of the candle material in a tared test glass and reweighing it after passing a current of dry air through it for several minutes. If the loss in weight exceeds 1 per cent, the presence of a volatile adjunct may be suspected, and the nature of same can be ascertained by a separate test, in which the volatile substance is condensed by the application of a low temperature.

The presence of B-naphthol is revealed, on the one hand, by the fruity-ether smell, and on the other, an exact determination can be made by shaking up the material with a little dilute alkali and adding one drop of a solution of diazochlorbenzol, a red coloration being produced, or a red precipitate if the amount of B-naphthol is large.

Vaseline oil is revealed by the greasy feel of the candles and the grease marks on the wrappers. This adjunct is hardly employed in practice, though it has been proposed on account of the well-known milky appearance of paraffin which contains oil.

TESTING THE BY-PRODUCTS OF TAR DISTILLATION.

The by-products in question consist of creosote oil, goudron, and asphaltum.

Creosote oil is tested for creosote, this being its most important constituent, at least for many purposes, such as impregnating timber. No accurate results can be obtained by shaking up the oil with concentrated soda lye, the neutral oils in creosote oil being soluble to a large extent in that reagent. On this account, caustic soda of 12° strength is used, being renewed until no further decrease in volume takes place. The difference between the initial and final quantities of oil corresponds to the creosote content.

The goudron is a black mass of about the consistence of dough. It should dissolve completely on extraction with benzol. The melting-point is determined by the method of Krämer and Sarnow, in which 5 grm. of mercury are placed in a glass tube about 5 to 6 mm. in diameter (Fig. 70), the lower end of which is then sealed up with a layer of goudron about 5 mm. high. This small apparatus is warmed in a water bath, the temperature of which is raised gradually. The temperature at which the column of mercury breaks through the goudron is the melting-point or softening point of the latter.

The same method is also applied in determining the melting-point of the asphaltum—the hard, glossy black residue from the distillation of the acid resins, the production of which has already been described in the technical portion of the present work. This asphaltum should,

for the most part at least, be soluble in benzol, though its solubility in this solvent is no measure of its solubility in oil of turpentine, benzine, etc., which varies considerably. Of course no guarantees of quality can be given for a waste product of this kind, and it is therefore preferably dealt with by sample, in so far as solubility is concerned, this being the plan adopted by the varnish maker for instance.

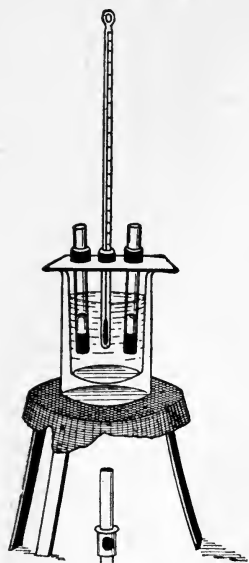

FIG. 70.

Melting point tester for goudron.

A comparatively new commercial product of the lignite-tar industry is lignite bitumen or mineral wax. The melting-point of this substance is determined by the method of Krämer and Sarnow. Other values to be determined are: the solubility in benzol (this should be as high as possible), the acid and ether values¹—by titrating 1 gm. of the finely powdered material with alcoholic caustic potash, in the known manner, after having been boiled with alcohol—and the ash content. In many cases it is important to test the ash for the presence of adjuncts, such as alkalis, heavy spar, baryta, which have been detected in many instances. Such test, however, only becomes necessary when the ash content considerably exceeds 1 per cent, in which case the assumption of extraneous

adjuncts becomes justifiable. For some purposes, e.g. the production of refined mineral wax, it is also important to ascertain the percentage of resinous constituents in the crude wax. This can be effected by shaking up 1 gm. of the very finely powdered mineral wax with two successive portions of ether (5 c.c.), and concentrating the filtrate. Another way is to extract 5 gm. of the finely powdered wax twice with 50 to 100 c.c. of hot alcohol, allowing the extract to cool, filtering off the deposited wax and concentrating the yellow or brown extract. The lower the proportion of such resinous bodies, the more valuable the wax, under otherwise equal conditions, for the production of refined mineral wax.

This brief sketch of the work to be done in the laboratories of the distillation-tar industry, is of course merely a summary of the general current operations. In many cases the methods of examination described have to be amplified by special investigations, which, however, cannot be gone into here owing to lack of space. A full description of the laboratory work in this industry has been given by Gräfe in his previously mentioned work on the subject.

¹ Gräfe, "Laboratoriumsbuch für die Braunkohlenteerindustrie," p. 152.

CHAPTER XII.

STATISTICS.

A. THE SAXON-THURINGIAN INDUSTRY.

THE economical development of the Saxon-Thuringian lignite-tar industry has had an exceedingly chequered history, the output and prices being high at one time and depressed at another. The circumstances influencing the business career of the industry will now be described.

When the industry first commenced, about the middle of the last century, a number of unqualified persons ventured on the production and treatment of lignite tar, in the expectation of making large profits with little trouble. They were destitute of any technical knowledge in the choice of raw material, or in respect of the apparatus required, the result being numerous cases of severe disillusion and the failure of many small enterprises; whereas others, possessing the requisite technical knowledge, worked at a profit in consequence of their skill in selecting the right material and appliances. The abundant supply of bituminous lignite was in many cases of far better quality than is now obtainable at all; and the cost of refining the products was small, there being no competition and therefore no high requirements in respect of quality. Hence the production and treatment of the tar were an easier matter than is now the case.

The practice now in force, of combining the raising of the lignite and the distillation of same under one management, was soon adopted. The mine owners erected distilling plant and built refineries for the oil and paraffin produced therein.

The prices obtained for the products were high in comparison with those now ruling, as is evident from the following comparison of the rates in 1858 and at the present day:—

	Then.	Now.
100 km. (2 cwt.) of lamp oil (solar oil)	54- 57 mk. (shillings)	13 mk.
" " paraffin (m.p. 53° C.)	270 " "	53 " "
" " lignite tar	30- 35 " "	3- 5 " "

This initial and troublous period of the industry was soon replaced by an era of more uniform and quiet development. In contrast to the present day, lamp oil and not paraffin was the main product. This oil found a ready sale, which was stimulated, early in the 'sixties, by

the growing importation of American petroleum; but the latter soon became a powerful competitor of the indigenous oil and set the market price of same. At that period the heavier lignite-tar oils found application as gas oils, the demand for which increased year by year; and the considerable extension of oil gas as an illuminant was of great importance to the industry during the 'sixties. This convenient illuminant was employed in industrial establishments, small towns adopted it, and most important of all, the German railways took up this form of lighting. Since that time the Saxon-Thuringian industry has been chiefly an oil producer, and has maintained a lively interest in matters relating to oil gas.

At the end of the 'sixties, the richer bituminous lignites were so far worked out that the poorer kinds had to be resorted to in order to keep the existing plant going. The poorer material, however, no longer yielded the same amount of products, the quantity of lamp oil decreased, and that of gas oil increased, finding a ready sale. To reduce the loss sustained over the most valuable products—lamp oil and paraffin—through the fall in prices, improvements in the manufacturing processes were introduced. The upright retort of Rolle, first successfully used at Gerstewitz, found wider application elsewhere. Grotowsky and Schliephacke introduced improvements in the distillation and refining processes, by means of which the cost of production was lessened.

The prices of the commercial products had fallen in 1869 to:—

	30 mk. (shillings) per 100 km. (2 cwt.) of lamp oil.	
120	„ „ „ „ „ „ „	paraffin.
15- 19	„ „ „ „ „ „ „	lignite tar.

all of which are very high in comparison with those now ruling. The tar output amounted to 37,500 tons.

In 1868 the mineral-oil works entered into closer association for the protection of their joint interests, and founded the Verein für Mineralölindustrie, which, under the direction of Krey, is still discharging its useful functions. From the early 'sixties, the paraffin was worked up in candle factories, associated in many places with the mineral-oil works. The chief centres of consumption for paraffin candles in Germany are in the east and south. At the end of the same decade, the production of composite and Christmas-tree candles was added to the paraffin-candle industry.

At the beginning of the 'seventies, by which time the Rolle retort had come into general use and low-grade lignite was being worked, the industry placed a new product on the market, namely coke, which had hitherto been regarded as a troublesome waste product—which it really was in the days of the horizontal retort and rich lignite. Now, however, it became an important article of commerce, forming a valuable fuel for the poorer classes of the population. Its economic importance to the industry grew from year to year; and at the present day, owing to the low prices of lignite-tar products, many, and indeed

most of the works, would be run at a loss if they were not able to dispose of the coke to advantage. The output of this retort coke is now about 400,000 to 420,000 tons per annum.

Up to 1870 the lignite of the Saxon-Thuringian industry was chiefly utilized by chemical preparation (dry distillation) only. Small quantities of lignite had been used as fuel, and another portion was made into briquettes by hand and dried, being sold as peat bricks for domestic fuel. It was not until the middle of the 'sixties that greater attention began to be devoted to the mechanical treatment of lignite, and, after years of experiment, the Hertel-Schmelzer wet press was found to solve the problem of turning out wet-pressed briquettes on a manufacturing scale by machinery.

Attempts were also made in the early 'seventies to make lignite briquettes with a binding medium, the manufacture of this product being taken up at about that time by Riebeck, subsequent to the experiments conducted by the Sächsisch-Thüringische A. G. für Braunkohlenverwertung at its Von der Heydt mine near Halle. The energy and activity of Riebeck were the cause of the rapid development of the mechanical preparation of lignite to such an extent that the quantity of material treated in this way soon exceeded that consumed for the production of tar. From that time onward, the works combined their distillation and mineral-oil plant with extensive factories for the production of wet-pressed blocks and briquettes. The growth of the trade in these fuels was accompanied by an increased use of crude lignite, this development being closely associated with that of other industries, such, for example, as the sugar and potash industries; and in this way compensation was established for the progressive decrease in the returns from the mineral-oil industry.

Attempts were made to counteract the continued fall in prices in this latter industry by improved technical methods. The output of tar was increased, and the cost therefore lowered. The expensive animal charcoal was replaced by cheaper decolorizing powders, and the large works introduced artificial cooling, by refrigerating machinery, for treating soft-paraffin masses. The former importance of solar oil had well-nigh vanished, its use as a lamp oil being insignificant in comparison with petroleum. In order to protect it against this powerful competitor, an import duty of 6 mk. per 100 km. (3s. per cwt.) was imposed on American petroleum in 1879, but without effect, the price of petroleum continuing to decrease, and with it the value of solar oil. Then the heavier oils, the gas oils, which had become the chief product suffered severely under the competition of foreign oils; and the extension of the above import duty to these and all other oils in 1885 was of considerable importance to the home industry. The duty on lubricating oils was raised to 10 mk. per 100 km. (5s. per cwt.), and a similar duty was laid on imported paraffin and all other solid illuminants (stearine, spermaceti, etc.), which urgently needed protection against foreign competition.

In order to maintain their position in the gas-oil market, the mineral-

oil works in 1885 formed a sales Syndicate, the Verkaufssyndikat für Paraffinöle in Halle a/S., an organization which subsequently embraced all lignite-tar oils, and is still in existence to the great benefit of the industry.

At the same time, another association, the Deutsche Braunkohlen-Industrie Verein, was founded to represent the economic interests of lignite mining. Its activity was of great value to the industry, and its labours in connection with the questions of railway rates and legislation are worthy of special praise. In 1901 an employers' association was formed among the members, and is now affiliated to the head association in Berlin.

The 'eighties witnessed the commencement of social-political legislation in Germany, beginning with the law of workmen's insurance against sickness (1883), which was followed by the accident insurance law and the laws relating to old age and invalidity insurance. Sick funds and workmen's co-operative insurance associations have been established at the various works in the lignite and mineral-oil industries.

During the second half of the same decade, gas oils found a ready sale; but, as a contrast, the early 'nineties were again unfavourable to the industry owing to the general economic depression. The economic position of the consumers of gas oil, namely the spinning, weaving, and sugar-refining industry, naturally reacts at all times on the mineral-oil industry. In the middle of the 'nineties, however, business improved once more, and the oils found buyers, even though at reduced prices.

With the commencement of the new century, the market for oils fluctuated considerably, and stocks increased from year to year. This state of things however, was succeeded by a period of active demand extending to the present day, the oil-producing industry being now a close corporation. The influence of new methods of application—such as the carburetting of water gas and the introduction of the Diesel engine—may be gathered from the statistical Table No. IV.

The new commercial treaties, which came into force on 1 March, 1906, reduced the import duty on oils for these two purposes from 6 mk. to 3 mk. per 100 km. (1s. 6d. per cwt.), and the duty on soft paraffin from 10 mk. to 8 mk. (4s. per cwt.), in spite of the endeavours of the industry to prevent any such reduction and to obtain an increase on the duty on paraffin.

In casting a final glance backward over the commercial career of the Saxon-Thuringian mineral-oil industry, the first thing noticeable is the continued retrogression in the price of its products. Apart from slight fluctuations, it is only since the beginning of the 'nineties that the prices of oil have remained stationary, the level being such, however, that no reduction is possible without rendering the business unprofitable. Paraffin prices fluctuate continuously, and depend entirely on the rates fixed by American and Galician producers.

The same state of things prevails in the candle market, the prices being regulated by both these of paraffin and stearine (including stearine candles). In the absence of a candle syndicate, underselling

and keen competition are rife on the part of the numerous German candlemakers who use imported paraffin. At present the market for paraffin and paraffin candles is in a very depressed condition; and as B. Leupold (Halle) rightly says in his report on the state of the market in the Saxon-Thuringian mineral-oil industry: "One may scan the records of the past forty to forty-two years in vain to discover such a depreciation in our paraffin and candles".

As set forth in Table I, the output of lignite tar has been free from any important fluctuations, and amounts to 60,000 tons per annum. There is, however, no expectation of any increase in this branch of the lignite industry of Central Germany. As already mentioned, the owners of the distilling and mineral-oil plants have, for several decades, associated the mechanical treatment of lignite with the chemical branch, and are going ahead in this direction, with the idea of balancing the fluctuating returns from the older branch by the solid benefits obtainable from the new departure. This was accomplished up to a few years ago, the extension of the briquetting works keeping pace with the demand for this fuel; but now so many new works of this kind have been established in all parts of Central Germany, that even the second support of the industry, though believed to be so strong, threatens to become a broken reed.

The graphical diagrams on following pages show the development of the industry during the past twenty years:—

Diagram V illustrates the tar output treated in the mineral-oil works.

Diagram VI shows the production of paraffin oil, which naturally coincides nearly with V.

Diagram VII shows the decline in the most valuable product of the industry, namely paraffin. The curve will be seen to have quite a different course than that in V since 1902, the tar worked having a much lower percentage of paraffin than formerly, being itself derived from inferior raw material.

Diagram VIII gives the prices for lignite tar.

Diagram IX gives the prices of gas oil. In neither case are the fluctuations so extensive as those shown in

Diagram X, representing the paraffin prices. (These, according to commercial usage, represent the value in marks, based on the melting-point of the paraffin.)

Diagram XI gives the candle prices, which, like those of the paraffin, fluctuate extensively.

SHALE OILS AND TARS

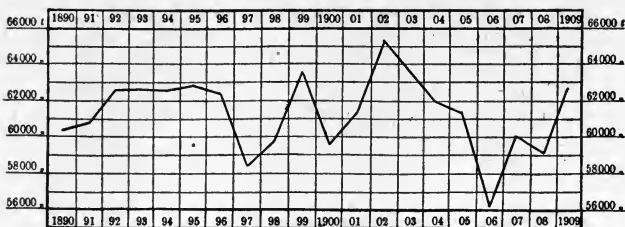

DIAGRAM V.—Tar output, metric tons.

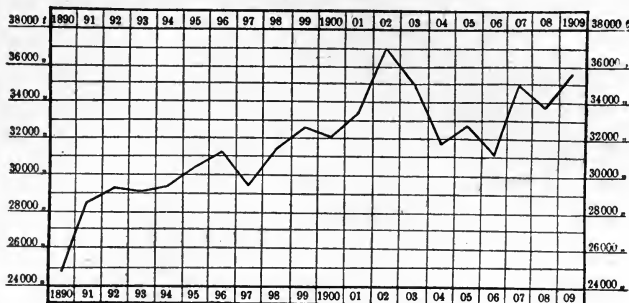

DIAGRAM VI.—Paraffin oil output, metric tons.

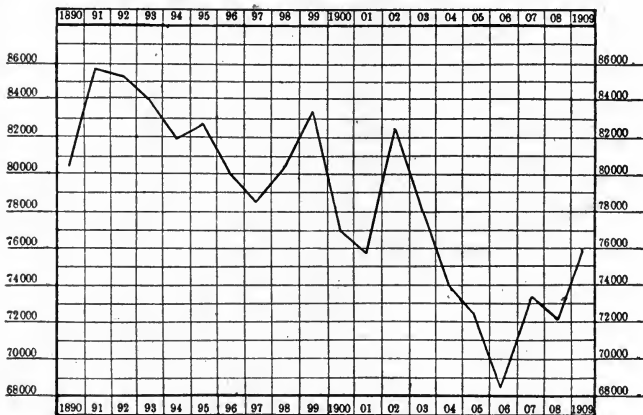

DIAGRAM VII.—Production of paraffin, 100 kilos.

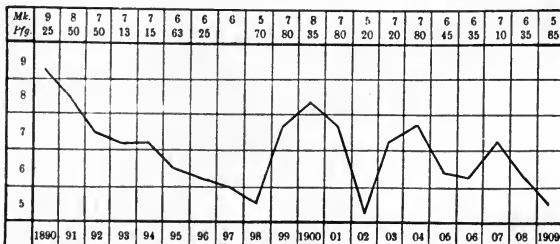

DIAGRAM VIII.—Price of lignite tar.

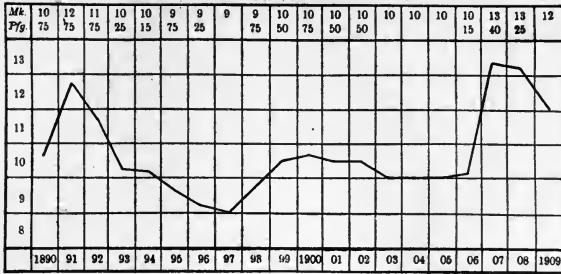

DIAGRAM IX.—Price of gas oil.

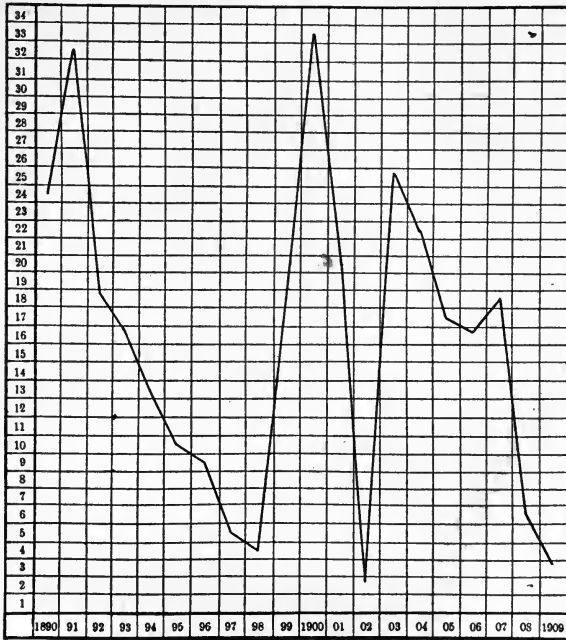

DIAGRAM X.—Price of paraffin.

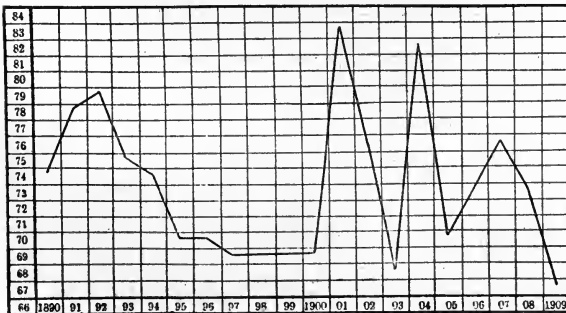

DIAGRAM XI.—Price of paraffin candles.

Additional statistical data are given in the subjoined tables :—

I. Lignite Distilleries in 1909.

No.	Name.	No of Retorts.	Lignite Consumed		Tar produced. Metric Tons.	No. of Hands.
			As Fuel	For Distilling.		
			Hectolitres. (1 hectol. = 2 $\frac{3}{4}$ bus.)			
1	A. Riebeck'sche Montanwerke, Akt.-Ges., Halle a. S.	469	1,505,615	6,398,340	22,769	367
2	Sächsisch Thüringische Aktiengesellschaft für Braunkohlenverwertung, Halle a. S.	144	760,190	2,287,445	10,151	132
3	Werschen-Weissenfelser Braunkohlen - Aktiengesellschaft, Halle a. S.	132	653,445	1,583,383	5,239	92
4	Zeitler Paraffin- u. Solarölfabrik, Halle a. S.	92	313,565	1,064,495	4,497	78
5	Waldauer Braunkohlen-Industrie-Akt.-Ges., Waldau	70	334,309	1,086,040	4,946	55
6	Konsol. Hallesche Pfännerschaft, Halle a. S.	36	109,295	667,730	3,055	20
7	Bruckdorf - Nietlebener Bergbauverein, Halle a. S.	24	75,950	571,249	3,108	27
8 ⁱ	Hugo Carlson, Wildschütz	60	165,595	811,090	2,332	31
9	Bunge & Corte, G. m. b. H., Halle a. S.	50	136,119	297,110	1,070	58
10	Braunkohlengrube Concordia, Gewerkschaft, Nachterstedt	72	403,470	1,042,700	3,967	76
11 ²	Naumburger Braunkohlen-Aktiengesellschaft, Naumburg	24	145,645	491,575	1,226	13
		1173	4,603,198	16,301,157	62,360	949

The capital invested in these works represents an aggregate of over £2,000,000.

II. Output of Retort Coke.

At the present time the output of this coke amounts to 400,000 to 420,000 tons per annum.

The gradual increase in the consumption is apparent from the following list :—

In 1883	the deliveries	amounted to	about	130,000	tons.
" 1884	" "	" "	" "	250,000	"
" 1893	" "	" "	" "	267,000	"
" 1898	" "	" "	" "	326,000	"
" 1900	" "	" "	" "	352,000	"
" 1902	" "	" "	" "	380,000	"
" 1905	" "	" "	" "	405,000	"
" 1909	" "	" "	" "	420,000	"

¹ These works were acquired by the Riebeck Co. (I) in 1910.

² *Ibid.* (1911).

III. Mineral Oil and Paraffin Works in 1909.

No.	Name.	Works.	Tar Treated. Metric Tons.	Lignite Fuel Consumed. Hectol.	No. of Hands.
1	A. Riebeck'sche Montan- werke, A. G., Halle.	Webau	12,050	980,595	495
2 ¹	Sächsisch-Thüringische A. G. f. Braunkohlen- verwertung, Halle.	Reussen	6780	186,910	47
		Oberöblingen	4984	184,880	93
		Gerstewitz	10,233	470,525	161
3	Zeitzer Paraffin- u. Solarölfabrik, Halle.	Aue and Döllnitz	9516	533,192	122
4	Werschen-Weissenfelser Braunkohlen A. G., Halle	Köpsen	5427	247,205 and 285 tons briquettes	126
5	Waldauer Braunkohlen- Industrie A. G., Halle	Waldau	4392	287,922	99
6	Bruckdorf-Nietlebener Bergbauverein, Halle	Nietleben	4027	64,883	20
7	Bunge & Corte, G. m. b. H., Halle	Oberöblingen	1070	62,090	23
8	Dorstewitz-Rattmans- dorfer Braunkohlen- Ind. Ges., Halle.	Rattmannsdorf	1633	100,038	42
9 ²	Hugo Carlson, Wild- schütz	Wildschütz	2332	19,020	25
			63,048	3,078,260	1253

The aggregate capital invested in these works is about £400,000.

IV. Consumption of Syndicate Oils for Various Purposes.

About 15,000 tons of gas oil are used every year in the production of oil gas for lighting railway carriages; and of this quantity over two-thirds, namely 11,000 tons, are supplied by the Verkaufs-Syndikat für Paraffinöle. A further 6000 to 7000 tons are sold for gasmaking in factories, gasworks, etc., the Syndicate furnishing about 5000 tons. The figures in this connexion show a decline of late years, having been 7200 tons in 1895, 7000 tons in 1900, and 6300 tons in 1903.

The consumption of lignite-tar oils for making cart grease fluctuates, being now about 1200 tons per annum, against 700 to 800 tons in earlier years.

Since 1898, mineral oil has been in demand for carburetted water gas, though it was not until 1901 that the consumption attained noteworthy dimensions, being then about 1800 tons. From that date the demand has grown extensively, and now exceeds 20,000 tons. About 10 to 15 per cent of this trade is conducted through the Syndicate.

¹ and ² See notes to preceding Table.

The consumption of mineral oils as a source of motive power in the Diesel engine has only become noticeable since 1903, from which time, however, it has largely increased, the quantity now exceeding 15,000 tons a year, about one-third of which passes through the hands of the Syndicate.

Like the production, the sales of solar oil—now only about 1500 tons per annum—has fallen from year to year, having been 4080 tons in 1898 and 2320 tons in 1901.

It should also be mentioned that the manufacture of lamp-black from oil gas has been entirely given up, though at one time about 1500 tons of gas oil were consumed annually for that purpose. The manufacturers, however, could not meet the competition of the cheap American lamp-black from natural gas, and were therefore obliged to give up the business.

V. Candle Statistics.

The production of the five candle works in this industry amounts to about 8000 tons of paraffin and composite candles per annum. About three-fourths of the output is produced by the Riebeck Co., and the remainder by the Werschen-Weissenfels Co. and Waldau Co. Candle factories are attached to the works at Webau, Oberöbblingen, Gerstewitz, Köpsen, and Waldau (Table III).

It may be of interest to append the German imports and exports of the above products for 1909 and 1910.

	Exports.		Imports.	
	1909.	1910.	1909.	1910.
1. Gas oil for engines or for carburetting water gas	—	—	30,165	30,368 tons
2. Paraffin, crude or refined	1086	883	15,105	17,047 „
3. Candles of all kinds	783	979	221	205 „

B. STATISTICS OF THE SCOTTISH SHALE INDUSTRY.

The retort has played a far more important part in the development of the Scottish shale industry than in that of Saxon Thuringia; for, whereas in the latter case the alterations in the retorts have been merely slight since the 'seventies, new types have been constantly introduced in Scotland down to within the past decade. The chief reason for this is, as already mentioned, the important rôle of the retort coke in the lignite-tar industry, which coke is obtained of excellent quality in the Rolle retort, so that there has been no inducement to modify the apparatus. The case is different in the Scottish industry, where the production of sulphate of ammonia takes corresponding rank to retort coke in Germany. At one time the tar water was thrown away, but since 1865 has been utilized for the recovery of sulphate of ammonia; and, as a rule, the modifications in the retorts have been due to attempts to increase the yield of ammonia. The apparatus now in use are of a thoroughly satisfactory character.

The properties of the raw material (shale) have not changed very much since the commencement of the industry; and the cost of raising the shale has also remained fairly stationary. Beilby¹ estimates the cost of raising shale, of quality similar to that of the Broxburn bed, as 5s. 1d. per ton (1 ton yielding 30 gal. of tar). The cost of raising the inferior shale from the deeper Dunnet, Barrwacks, and Pumpherston seams is estimated at 4s. 1d. per ton.

Keeping down the cost of raising the raw material is at all times an important factor in the success of distillation works; and in this respect the Saxon-Thuringian industry has an advantage over the Scottish industry inasmuch as only the smaller portion of the material raised is used for distilling, the remainder being put through mechanical treatment. This extensive output from the mines enables the cost per unit to be reduced, thus furnishing the distilling plant with cheap raw material.

The Scottish industry, however, has succeeded in lowering the cost of distilling and manufacturing from year to year by the continuous introduction of improved methods and appliances. One example will illustrate this clearly.

At the end of the 'sixties, the raw material for the distilling plant cost 5s. 1d. per ton, and the expense of distilling and refining the tar from same amounted to 5s. 7½d. per ton. With the high prices then ruling, the profit on the products obtained from 1 ton of shale was 9s. 8¾d. On the basis of the present low prices, and assuming the cost of production to have remained the same, there would be a loss of 4s. 3¾d.

Subsequently, however, the cost of dry distillation was reduced considerably, being 2s. 7d. per ton of shale in 1882, and 2s. 0½d. in 1897. At the same time the expense of distilling and refining the tar products was reduced to 3s. 7d. in 1882 and 1s. 11½d. in 1897; so that in the former year the profit per ton of shale amounted to 3s. 10½d., and in the latter year to 2s.

As in the German industry, the selling prices of the chief commercial products have fallen continuously, and are very low at present; and only the old-established works, which shared in the period of prosperity and have accumulated large reserves, have been able to distribute dividends.

The output of shale increased from 1,000,000 tons in 1880, to over 2,250,000 tons in 1890, and now exceeds 2,500,000 tons. There has been a growth in the amount of tar subjected to further treatment, the quantity at present being about 250,000 tons per annum, or more than four times the weight of lignite tar treated in the German industry.

The sulphate of ammonia produced amounts to 50,000 to 60,000 tons per annum.

The output of commercial products is about:—

¹ "Journ. Soc. Chem. Ind.," 1897, pp. 876 *et seq.*

Naphtha	2,376,000 gal.
Illuminating oils of all kinds	16 200,000 „
Gas oils	38,600 tons.
Lubricating oils	40,600 „
Paraffin	22,800 „
Retort coke	5000 „

The difficulties with which this industry has had to contend may be gathered from the fact that, out of 117 works which have been established at one time or another, only six are still in operation, the others having succumbed to unfavourable circumstances. The six concerns are: Broxburn Oil Co., Dalmeny Oil Co., Oakbank Oil Co., Pumphreyston Mineral Oil Co., Tarbrax Oil Co., and Young's Paraffin Co.

The number of retorts in work exceeds 1500. Four of the companies have mineral oil and paraffin works, and two have candle factories attached to the premises. The industry employs 8300 hands, of whom 3380 are miners; and the aggregate wages' bill amounts to about £700,000.

[THE END.]

INDEX.

A

- Accumulator for hydraulic press, 104.
- Agitator house, description of, 92.
- Agitators, description of, 87.
- Alkali—
 - Amount used in refining tar products, 90.
 - Recovery of the spent, 96.
- Alkalinification, 87.
- American petroleum, influence of, 167.
- Ammonia—
 - Determination of, 154.
 - Liquor, 53.
 - Recovery apparatus, 56.
 - of, 40.
 - of, from Messel tar, 37.
 - Sulphate of, from Messel tar, 56.
 - of, from shale tar, 56.
- Ammoniacal vapours, treatment of, 57.
- Ammonium salts, influence of, on wicks, 130.
- Analysis of—
 - Gas from shale-tar retorts, 85.
 - Gases from tar distilling, 77.
 - Lignite, 148.
 - ash, 14.
 - Pyropissit, 13.
 - Retort gas, 58.
 - Shale ash, 15.
 - Tars, 151.
- Aniline dyes, use of, in candle-making, 131.
- from tar, 142.
- Apparatus for—
 - Continuous distillation, 71.
 - Tar distilling, 65.
 - The Messel distillation process, 80.
- Aromatic hydrocarbons in lignite tar, 140.
- Arsenic in acid, effect of, 157.
- Ash, determination of, 154.
- Asphaltum—
 - Properties and uses of, 119.
 - Tests of, 163.

- Aspirator, description of, 153.
- Australian bitumen, 12.

B

- Barrels for oil storage, preparation of, 114.
- Baryta, use of, in refining tar products, 89.
- Battery of retorts, 33, 40.
- Beilby's retort, 44.
- tar water apparatus, 56.
- Benzine—
 - As washing agent for paraffin, 104.
 - From shale-tar distillation, 85.
 - Obtained in the Scottish industry, 123.
 - Properties and treatment of, 77.
 - — uses of, 115.
 - Tests of, 158.
- Bitumen—
 - Australian, 12.
 - Definition of, 19.
 - Determination of, 150.
 - Separation of, 18.
 - Solvents of, 13.
 - Uses of, 19.
- Bituminous coal, distillation of, in Germany, 7.
- lignite, estimation of tar yield from, 148.
- — origin of, 10.
- — testing of, 147.
- material, deposits of, 8.
- — separation of, 17.
- shales, deposits of, 9.
- — origin of, 12.
- Bleaching agents used for paraffin, 107.
- paraffin, method of, 107.
- sun, 91.
- Blue oil, 82.
- Bricked retort, section of, 26.
- Bricks for Rolle retort, 24.
- Brine, use of, 99.
- Briquettes from lignite, 167.
- manufacture of, 17.
- Bryson's retort, 48.

C

- Calorific power, determination of, 154.
 — value of coke, 61.
 — — of distillation gas, 40.
 — — of gas oil, 116.
 — — of gases from tar distilling, 77.
 — — of oils, 156.
 — — of retort gas, 59.
 — — significance of the, 156.
 — — waste gases, 40.
- Candle-making, history of, 125.
 — market, economic conditions of the, 169.
 — production, statistics of, 174.
 — waste, working up, 137.
 — wicks, tests of, 161.
- Candles—
 Colouring of, 131.
 Composite, 128.
 Cutting, 136.
 Dipping, 132.
 Early manufacture of, 3.
 — use of, 127
 Finishing processes for, 136.
 Manufacture of, 125.
 Moulding, 132-4.
 Polishing, 136.
 Raw material for, 127.
 Sizes and shapes of, 136.
 Tests of, 159.
- Carbolic acid, 141.
- Carbon disulphide in lignite tar, 143.
- Carburetted water gas, advantages of, 117.
- Carburetted water gas, 116.
 — — — influence of, 168.
- Caustic soda—
 For refining, 86.
 Tests of, 157.
 Use of, in refining tar products, 89.
- Cellulose, decomposition of, 11, 19.
- Centrifugal separators, 101.
- Charging retorts, 70.
 — — treatment of material for, 31.
- Chemical bleaching of paraffin, 105.
 — treatment, tar products to be dealt with, by, 90.
 — — of distillates, 64.
 — — of tar, 88.
 — — of wicks, 130.
- Clarifying candles, process of, 134.
- Cleaning condenser in tar distillation, 70.
 — oil, properties and uses of, 116.
 — — treatment of, 90.
 — retorts, 32.
- Coal, dry distillation of, 1.
 — testing of, 148.
- Coke—
 Amount of, in lignite, 14.
- Coke—
 As a purifier, 63.
 Calorific value of, 61.
 Cooling methods of, 32.
 Effect of salt on, 154.
 Estimation of, 149.
 Extraction of, from retorts, 31.
 For heating purposes, 62.
 From lignite tar, uses of, 76.
 — retorts, properties of, 61.
 — shale tar, 84.
 Influence of, on the oil industry, 166.
 Output of, 173.
 Residue from Messel coal, 37.
 Tests of, 153.
 Used for pigments, 63.
- Coking stills for shale tar, cleaning, 81.
- Colouring matters for candles, 131.
 — — — tests of, 161.
- Condensers, 50.
 — used in tar distilling, 67.
- Condensing plant for lignite tar, 28.
- Cone and bell for Rolle retort, 25.
- Constituents of lignite tar, 144.
 — of shale tar, 146.
- Consumption of fuel in tar distilling, 71.
- Continuous distillation, apparatus for, 71.
 — process of distillation, of shale tar, 81.
 — working retorts for lignite tar, 22.
- Coolers, 23.
- Cooling processes in candle manufacture, 135.
 — towers, 41.
 "Cracking," 65.
- Creosote, 37.
 — determination of, 152.
- Creosote oil—
 Properties and uses of, 119.
 Tests of, 163.
- Creosotes from lignite tar—
 Properties of, 142.
 Sulphur compounds of, 141.
- Crichton's retort, 47.
- Crude paraffin, early methods of refining, 103.
 — — press plant for, 105.
- Crude oil, 81.
 — — analysis of, 152.
 — — composition of, 146.
 — — from lignite tar, properties of, 76.
 — — properties of, 53.
 — — treatment of, 77.
 — — yield from, in the Scottish industry, 122.
- Crusher for paraffin masses, 100.
- Crystallization of paraffin, 97, 98.
 — — — in the Messel industry, 108.
 — — — in Scottish industry, 109.

D

- Decolorizing agents, tests of, 158.
 — of paraffin, agents used in, 107.
 — paraffin in the Scottish industry, 112.
 Decomposition of—
 Paraffin, prevention of, 70.
 Shale tar, 83.
 Dialysis of paraffin, 98.
 Diesel motor—
 Action of the, 117.
 Influence of the, 168.
 — motors, oil for, 117.
 Distillates from tar, 138.
 Distillation—
 At atmospheric pressure, plant used
 in, 67.
 Description of process of, 69.
 Gas, calorific value of, 40.
 In partial vacuo, advantages of, 71.
 — — — plant used in, 67.
 Methods of, 64.
 Plant, used in, 33, 67.
 Plants, introduction of, into Ger-
 many, 5.
 Products from the Messel process, 80.
 — testing the, 151.
 Steam, see steam distillation.
 Tar, value of, 53.
 Yield and cost of, of shale tar, 51.
 Dry distillation—
 Process of, 29.
 Of tar, 20.
 Of coal, 1.
 Duty on oil, 167.
 Dye-stuffs in candle-making, properties
 of, 161.

E

- Early methods of refining crude paraffin,
 104.
 Eupion, 2.
 Exhausters, 23.
 Exhaust fans, 41.
 Explosions, prevention of, 30.

F

- Fat oil, properties and uses of, 118.
 Filter press, for paraffin, 100.
 Finishing processes for candles, 136.
 Firebricks for retort building, 27.
 Flat wicks, advantage of, 130.
 Fractional analysis, 155.
 Frankfurt black, 63.
 Fuller's earth, use of, 158.

G

- Gas, amount of, in lignite, 14.
 — engines for waste gases, 61.

- Gas, from retorts as illuminating gas,
 61.
 — — — properties of, 58.
 — oil, 78.
 — — consumption of, 173.
 — — from shale tar, 84.
 — — price of, diagram showing, 171.
 — — properties and uses of, 116.
 — — treatment of, 90.
 Gases from shale tar distillation, analysis
 of, 85.
 Gay-Lussac's analysis of paraffin, 2.
 Geological features of deposits, 9, 12.
 Glauber salt, formation of, 94.
 "Goudron," 94.
 Goudron, 72, 119.
 — tests of, 163.
 Green oil—
 Chemical treatment of, in the Scottish
 industry, 93.
 Treatment of, 83.
 Grouven's process of ammonia recovery,
 37.

H

- Hard paraffin mass from shale tar, 83.
 Heating of candle material, 134.
 — of mixers, 88.
 Heating of retorts, 29.
 Heavy burning oil from shale tar, 83.
 — oil of the Scottish industry, 94.
 Henderson's retort, 42, 46.
 — tar water apparatus, 57.
 Horizontal hydraulic press, 103.
 Hydraulic press for paraffin, 100, 102.
 Hydrocarbons—
 Aromatic, in lignite tar, 140, 141.
 Composition of, 139.
 Condensation of heavy, 29.
 In lignite tar, 139.
 Of the paraffin series, 144.
 Production of saturated, 139.
 Reactions of, 140.
 Unsaturated, indications of, 140.
 — properties of, 140.

I

- Illuminating power of candles, 129.
 — value of candle material, determina-
 tion of, 162.
 Isolation of paraffin, 98.

L

- Laboratory, functions of the, 147.
 — work of the, 147.
 Lamp oil—
 From the Messel distillation, 80.
 — shale tar, 84.
 Solar oil used as, 115.

- Lamp oils, recovery of, by distillation, 72.
 Leaching, 90.
 Lead for mixer linings, 87.
 Light lignite-tar oil, properties and uses of, 115.
 — oil, from shale tar, 83.
 Lignite—
 Ash, analysis of, 14.
 Bitumen, tests of, 164.
 Briquettes, 167.
 Deposits of, 8.
 Distilleries, list of, in 1909, 172.
 Method of working deposits of, 15.
 Mining, Federation of, in Germany, 168.
 Pitch, properties and uses of, 119.
 Tar, yield of, in Saxon Thuringian industry, 113.
 — distillation of, 68.
 — formation of, 138.
 — industry, development of, 169.
 — oils, consumption of, 173.
 — output of, 169.
 — price of, diagram showing, 170.
 — substances contained in, 144.
 — water, 54.
 Lignites—
 Composition of, 12.
 Properties and analysis of, 12.
 Lime, use of, in refining tar products, 89.
 Lubricating oils, 119.
 — — from shale tar, 83.

M

- Melting-point—
 Determination of, 156.
 Of paraffin, 121.
 — — determination of, 153, 159.
 — — points of paraffin candles, 128.
 Messel coal—
 Coke from, 37.
 Extraction of tar from, 36.
 Method of working, 17.
 Properties of, 14.
 — distillation process, apparatus for the, 80.
 Mineral oil—
 Consumption of, 174.
 Works, list of, 173.
 — Federation of, in Germany, 166.
 Mineral wax, 18.
 — — distillation of, 138.
 — — tests of, 164.
 Mixers, description of, 87.
 Moisture, determination of, 153, 156.
 Motor spirit, 85.
 — — obtained in the Messel industry, 122.
 — — — — — Scottish industry 123.

- Moulding candles, 132.
 — machine for candles, method of operating, 134.
 Moulds for candles—
 Materials used in, 133.
 Method of working, 132.

N

- Naphtha—
 Obtained in the Scottish industry, 123.
 Output of, 176.
 Properties and treatment of, 83.
 Naphthalene—
 Decomposition of, 141.
 Formation of, 140.
 Naphthol in candles, detection of, 163.
 Neutral oils, treatment of, 143.
 Nitriles from tar, 142.
 Nitrogenous constituents of tar, 142.
 — — in tar, 138.
 Non-bituminous coal, use of, 17.

O

- Oil—
 Blue, 82.
 Crude, see Crude oil.
 Fat, 118.
 For Diesel motors, 117.
 Fuel for steam raising, 118.
 Gas, 116.
 — lighting, adoption of, by German railways, 166.
 Green, 83, 93.
 Heavy, 83, 94.
 Lamp, 72, 80, 84, 115.
 Mineral, consumption of, 173.
 Shale, properties and yield of, 15.
 Shales, distillation of, in America, 4.
 Tar from lignite, 29.
 Washery, 41.
 Washing, 87.
 Oils—
 Lubricating, 83, 119.
 Obtained in the Messel industry, 122.
 — — Saxon - Thuringian industry, 113.
 — — the Scottish industry, 122.
 Treatment of, in the Scottish industry, 94.
 Oleic acid, properties of, 128.
 — — tests of, 160.
 Origin of bituminous lignite, 10.
 — — — shales, 12.

P

- Packing candles, 137.
 Paraffin candles, price of, diagram showing, 171.

- Paraffin**—
- Analysis of, 2.
 - Bleaching, 107.
 - Chief uses of, 121.
 - Composition of, 2.
 - Condensation of, 29.
 - Crystallization of, 89.
 - Detection of, in distillate, 151.
 - Determination of heavy oils in, 159.
 - Dirt in, determination of, 157.
 - Discovery of, 1.
 - Dialysis of, 98.
 - Effect of mixture with stearine, 129.
 - Filtering, 100.
 - For candles, tests of, 160.
 - From wood tar, 2.
 - Grease, properties of, 76.
 - — and uses of, 119.
 - treatment of, in Scottish industry, 123.
 - Hard, 83.
 - In the Saxon-Thuringian industry, 97, 98.
 - In tar, determination of, 152.
 - Manufacture of, 97.
 - Mass, treatment of, 76.
 - yield of crude petroleum from, 102.
 - Melting-point of, 12, 153, 159.
 - Obtained in the Messel industry, 122.
 - — — Scottish industry, 123.
 - Oil output, diagram of, 170.
 - Press for, 100, 102.
 - Price of, diagram showing, 171.
 - Properties and uses of, 120.
 - Scale sweating process described, 109.
 - dissolving, 104.
 - treatment of, 103.
 - Solvents for, 120.
 - Tar from lignite, 29.
 - Tests of, 158.
 - Treatment of, after refining, 98.
 - of, in Messel industry, 108.
 - of, in the Scottish industry, 109.
 - Works, list of, 173.
 - Yield of crude, 102.
- Peat**, dry distillation of, 2.
- Petroleum paraffins, use of, in candle making, 128.
- Phenols, existence of, in tar, 141.
- isolation of, 141.
 - Photogen, 115.
 - Picene, formation and properties of, 141.
 - Plant used for distilling shale tar, 83.
 - — in the distillation of tar, 74.
 - Polishing candles, 136.
 - Potassium ferrocyanide use of, 158.
 - Pouring candle material, conditions of, 134.
 - Pressing paraffin in the Messel industry, 108.
 - paraffin, method of work in, 100.
- Press oils, distillation and properties of, 78.
- plant for paraffin, 105.
 - Production of paraffin, 64.
 - — — diagram of, 17
- Products obtained from lignite tar distilling, 77.
- of distillation, 52.
 - — — of lignite tar, 76.
 - — — of shale tar, 83.
 - of Saxon-Thuringian industry, 113.
 - of the Messel industry, 122.
 - — — Scottish industry, 122.
- Properties of crude oil, 53.
- of lignite tar, 52.
 - of retort gas, 58.
 - of shale tar, 53.
- Purification of paraffin with steam, 106.
- of tar water from lignite, 54.
- Pyridin bases, uses of, 120.
- — recovery of, 91.
 - properties and uses of, 142.
- Pyrocatechin, formation of, 142.
- Pyropissit, analysis of, 13.
- composition of, 10.

Q

Quinolin from tar, 142.

R

Ramdohr's method of distillation, 20.

Raw material, treatment of, 40.

- — — for shale tar, 50.
- materials, sampling and testing, 147.

Reagents, use of, 87.

Red product, 151.

- — from lignite tar, 76.

Refining in the Scottish industry, 93.

- of lignite tar, 87.
- of tar and its distillates, 86.

Refrigerating machinery, use of, 99.

Reichenbach, Baron von, discovery of paraffin, 1.

Residue from distillation of Messel tar, 40.

Residues of distillation, 61.

- treatment of, in the Messel industry, 63.

Resinous constituents of wax, determination of, 164.

Resins, acid, 87.

- — separation of, 91.
- — treatment and properties of, 94.
- uses of, 94.

Retort charging for lignite tar, 22, 31.

- — treatment of material for, 31.
- coke, output of, 172.
- for estimation of tar yield, 148.
- gases, consumption of, in motors, 60.

Retort houses, 35.
 Retorts, 21-7, 29-52.
 — amount of material distilled in, 31.
 — arrangement of, 33.
 — cleaning of, 32.
 — cooling of, 33.
 — development of, 50.
 — difficulties in working, 33.
 — for tar distilling, 65, 79.
 — heating of, 29, 39, 50.
 — method of working, 50.
 — — for lignite tar, 27.
 — quantity of shale distilled in, 47.
 — shape of, for lignite tar, 21.
 — types of, for shale tar, 41.
 — vertical, dimensions of, 23.
 — work done in, 39.
 — working process of, 39.
 Rolle retort, 22-26.
 Rotary retorts, 27.

S

Salt, effect of, on coke, 154.
 Sampling raw materials, 147.
 Saxon-Thuringian industry, history of the, 165.
 — — — manufacture of paraffin, 98.
 — — — products obtained in, 113.
 — — — treatment of paraffin, 98.
 Scottish industry, refining process in the, 93.
 Scrubbing retort gases, 60.
 Separation of bituminous and non-bituminous material, 17.
 — of paraffin, 97.
 — of water from tar, 89.
 Shaft mining, in lignite deposits, 16.
 Shale beds, method of working, 17.
 — industry, statistics of, 174.
 — output of, 175.
 — — of products from, 175.
 — tar, apparatus for distilling, 81.
 — — composition of, 146.
 — — cost of distilling, 51.
 — — decomposition of, 83.
 — — James Young's distillation of, 3.
 — — recovery of, 41.
 — — retorts for, 41.
 — — temperature in retorts for, 45, 46.
 — — water, 56.
 Silicates of aluminium and magnesia, use of, 158.
 Soap from candle waste, 137.
 Soda-tar, 87.
 — — decomposition of, 95.
 — — properties and uses of, 119.
 — — uses of, 94.
 Sodium carbonate, use of, in refining tar products, 89.

Soft paraffin mass from shale tar, 83.
 — — use of, in candle-making, 128.
 Solar oil—
 Consumption of, 174.
 Properties and uses of, 115.
 Treatment of, 90.
 Solidification point, determination of, 155.
 Solubility of paraffin and oils, 98.
 Standard alkali, 162.
 Steam distillation, description of process of, 71.
 — jet treatment of paraffin, 106.
 — raising with oil fuel, 118.
 — use of, in distillation process, 20.
 — — of, in purification of paraffin, 106.
 Stearic acid, determination of, 162.
 Stearine, effect of mixture with paraffin, 129.
 — properties and uses of, 123.
 — receptacles for, 134.
 — soap, 137.
 — substitutes for, 129, 163.
 — tests of, 160.
 — varieties of, 160.
 Stills used for continuous process of distillation, 81.
 — — in the Messel process, 80.
 Storage of stearine, 134.
 — of wick, 131.
 — tanks for oil, 113.
 Stoves for coke burning, 62.
 Sugar industry, influence of, 101.
 — refining industry, influence of, 163.
 Sulphate of ammonia, output of, 175.
 Sulphur compounds in lignite tar, origin of, 142.
 — determination of, 155.
 Sulphuretted hydrogen, determination of, 154.
 — — from tar, 143.
 Sulphuric acid—
 Effect of impurities in, 157.
 For refining, 86.
 Tests of, 157.
 Use of, in refining tar products, 89.
 Sun bleaching, 91.
 Sweating house, description of, 110.
 — process, description of, 110.

T

Tapering candles, 136.
 Tar—
 Amount of, in lignite, 14.
 Chemical treatment of, 88.
 Determination of quality, 151.
 Distillates from, 138.
 — in France, 2.
 Distillation of, in Australia, 7.
 Distilling, apparatus used in, 65.

- Tar—**
 Dry distillation of, 20.
 Earliest distillation of, 1.
 Estimation of yield from lignite, 148.
 Extraction of, from Messel coal, 36.
 From lignite, properties of, 52.
 — shale, properties of, 52.
 Loss in manufacture, 149.
 Oils, distillation of, 82.
 — testing of, 154.
 Output, diagram of, 170.
 Products for chemical treatment, 90.
 Refining, 86.
 Testing of, 150, 151.
 Water, 53.
 — estimation of, 149.
 — from Messel coal, 55.
 — purification of, from lignite, 54.
 — tests of, 150.
 — value as a manure, 54.
 Yield from, in the Messel industry, 122.
 — of, 33.
 — of from Messel coal, 19.
- Temperature, chemical action due to, 20.
 — influence of, in tar distillation, 139.
 — of pouring candle material, 136.
 — of retort flues, 30.
 — of waste gases, 39.
- Testing raw materials, 147.
 — the by-products of tar distillation, 163.
- Time occupied in distilling, 70.
- Treatment of ammoniacal vapours, 57.
 — of oils, 90.
 — of paraffin in the Messel industry, 108.
 — — — in the Scottish Industry, 109.
 — of permanent gases, 76.
 — of raw material, 40.
 — of residue in the Messel process, 80.
 — of residues in the Messel industry, 63.
 — — — in tar distilling, 70.
 — of tar for distillation, 69.
- Treatment of vapours, from Messel tar, 40.
- Trinkler motor, principle of the, 118.
- U**
- Utilization of retort gas, 59, 61.
 Utilizing waste gases, 40.
- V**
- Vapours from distillation, treatment of, from Messel tar, 40.
 Vaseline oil in candles, detection of, 163.
 — — properties and uses of, 115.
 — oils, treatment of, 90.
 Vertical hydraulic press, 102.
 — retorts, introduction of, 166.
 — — for lignite tar, 22.
- Viscosity of oils, determination of, 155.
 — of solar oil, 115.
 — of vaseline oil, 115.
- Volatile oil, washing of, 41.
- W**
- Washing agents for paraffin, 104.
 Waste products, recovery of, 95.
 Water, determination of, in lignite, 148.
 — gas manufacture of, 116.
 — separation of, from tar, 89.
- Whiteness of candles, substances producing, 129.
- Wick, method of supporting in moulds, 133.
- Wicks, manufacture of, 130.
 — weight of, 130.
- Y**
- Yarn for wicks, 130.
 Yellow oil, treatment of, 90.
 Young, James, treatment of shale tar by, 3.
 Young's retort, 42.

OLD FOUNDRY
HULL

Established 1777

ROSE, DOWNS & THOMPSON,

LTD.

Specialists in the
Manufacture of

OIL MILL MACHINERY

**EXPRESSING PLANTS AND ALSO
CHEMICAL OIL EXTRACTION**

By Benzine or Non - Inflammable Solvents

COMPOUND FEEDING CAKE MACHINERY

Complete Installations to Produce
FISH OIL, MEAL, AND MANURE

(New Process—Recently Patented)

Branch Offices—

12 MARK LANE, LONDON, E.C.

20 FOOCHOW ROAD, SHANGHAI

Abridged Catalogue OF Special Technical Books.

INDEX TO SUBJECTS.

	PAGE		PAGE		PAGE
Agricultural Chemistry	9	Engraving	23	Pottery Decorating	11
Air, Industrial Use of	10	Essential Oils	7	Pottery Manufacture	11
Alum and its Sulphates	8	Evaporating Apparatus	19	Pottery Marks	12
Ammonia	8	External Plumbing	20	Power-loom Weaving	14
Aniline Colours	3	Fats	6	Preserved Foods	22
Animal Fats	6	Faults in Woollen Goods	15	Printers' Ready Reckoner	23
Anti-corrosive Paints	4	Flax Spinning	18	Printing Inks	3, 4, 5
Architecture, Terms in	22	Food and Drugs	22	Recipes	3
Architectural Pottery	12	Fruit Preserving	22	Resins	3
Artificial Perfumes	7	Gas Firing	19	Ring Spinning Frame	9
Balsams	9	Glass-making Recipes	13	Risks of Occupations	10
Bleaching	17	Glass Painting	13	Riveting China, etc.	12
Bleaching Agents	17	Glue-making and Testing	18	Sanitary Plumbing	20
Bone Products	8	Greases	6	Scheele's Essays	8
Bookbinding	23	Gutta Percha	11	Sealing Waxes	11
Brick-making	11, 12	Hat Manufacturing	15	Shale Oils and Tars	10
Burnishing Brass	20	Hemp Spinning	18	Shoe Polishes	6
Carpet Yarn Printing	16	History of Staffs Potteries	12	Silk Dyeing	17
Casein	4	Hops	21	Silk Throwing	17
Celluloid	23	Hot-water Supply	21	Smoke Prevention	19
Cement	22	India-rubber	11	Soap Powders	7
Ceramic Books	11	Industrial Alcohol	9	Soaps	7
Charcoal	8	Inks	3, 4, 5, 9	Spinning	15, 17, 18
Chemical Analysis	8	Iron-corrosion	4	Spirit Varnishes	5
Chemical Essays	8	Iron, Science of	19	Staining Marble, and Bone	23
Chemical Reagents	8	Japanning	21	Stain-removing Soaps	7
Chemical Works	8	Jute Spinning	18	Steam Drying	10
Chemistry of Pottery	12	Lace-Making	15	Steel Hardening	19
Clay Analysis	12	Lacquering	20	Sugar Refining	23
Coal-dust Firing	19	Lake Pigments	3	Sweetmeats	22
Colour Matching	16	Lead and its Compounds	10	Technical Schools, List	24
Colliery Recovery Work	18	Leather-working Mater'ls	6, 11	Terra cotta	11
Colour-mixing for Dyers	16	Libraries	24	Testing Paint Materials	4
Colour Theory	16	Linoleum	5	Testing Yarns	15
Combing Machines	18	Lithography	23	Textile Fabrics	14, 15
Compounding Oils	6	Lubricants	6	Textile Fibres	14
Condensing Apparatus	19	Manures	8, 9	Textile Materials	14
Cosmetics	7	Meat Preserving	22	Timber	21
Cotton Dyeing	17	Medicated Soaps	7	Toilet Soapmaking	7
Cotton Spinning	17, 18	Metal Polishing Soaps	7	Varnishes	5
Cotton Waste	18	Mineral Pigments	3	Vegetable Fats	7
Damask Weaving	15	Mineral Waxes	6	Vegetable Preserving	22
Dampness in Buildings	22	Mine Ventilation	18	Warp Sizing	16
Decorators' Books	4	Mine Haulage	18	Waste Utilisation	9
Decorative Textiles	15	Mining, Electricity	19	Water, Industrial Use	10
Dental Metallurgy	19	Needlework	15	Water-proofing Fabrics	16
Disinfectants	9	Oil and Colour Recipes	3	Waxes	6
Drugs	22	Oil Boiling	5	Weaving Calculations	15
Drying Oils	5	Oilmen Sundries	3	White Lead and Zinc	5
Drying with Air	10	Oil Merchants' Manual	6	Wiring Calculations	21
Dyeing Marble	23	Oils	6	Wood Distillation	21
Dyeing Woollen Fabrics	17	Ozone, Industrial Use of	10	Wood Extracts	21
Dyers' Materials	16	Paint Manufacture	3	Wood Waste Utilisation	22
Dye-stuffs	17	Paint Materials	3	Wood-Dyeing	23
Edible Fats and Oils	7	Paint-material Testing	4	Wool-Dyeing	17
Electric Lamp Develop- ment	21	Paint Mixing	3	Woollen Goods	15, 16, 17
Electric Wiring	20, 21	Paper-Mill Chemistry	13	Woven Fabrics	16
Electricity in Collieries	18	Paper-pulp Dyeing	13	Writing Inks	9
Emery	24	Petroleum	6	X-Ray Work	11
Enamelling Metal	13, 21	Pigments, Chemistry of	3	Yarn Sizing	16
Enamels	13	Plumbers' Work	20	Yarn Testing	15
Engineering Handbooks	19	Pottery Clays	12	Zinc White Paints	5

PUBLISHED BY

SCOTT, GREENWOOD & SON,
8 BROADWAY, LUDGATE, LONDON, E.C.

FULL PARTICULARS OF CONTENTS

Of the Books mentioned in this **ABRIDGED CATALOGUE**
will be found in the following Catalogues of

CURRENT TECHNICAL BOOKS.

LIST I.

Artists' Colours—Bone Products—Butter and Margarine Manufacture—Casein—Cements—Chemical Works (Designing and Erection)—Chemistry (Agricultural, Industrial, Practical and Theoretical)—Colour Mixing—Colour Manufacture—Compounding Oils—Decorating—Driers—Drying Oils—Drysaltery—Emery—Essential Oils—Fats (Animal, Vegetable, Edible)—Gelatin—Glues—Greases—Gums—Inks—Lead—Leather—Lubricants—Oils—Oil Crushing—Paints—Paint Manufacturing—Paint Material Testing—Perfumes—Petroleum—Pharmacy—Recipes (Paint, Oil and Colour)—Resins—Sealing Waxes—Shoe Polishes—Soap Manufacture—Solvents—Spirit Varnishes—Varnishes—White Lead—Workshop Wrinkles.

LIST II.

Bleaching—Bookbinding—Carpet Yarn Printing—Colour (Matching, Mixing Theory)—Cotton Combing Machines—Dyeing (Cotton, Woollen and Silk Goods)—Dyers' Materials—Dye-stuffs—Engraving—Flax, Hemp and Jute Spinning and Twisting—Gutta-Percha—Hat Manufacturing—India-rubber—Inks—Lace-making—Lithography—Needlework—Paper Making—Paper-Mill Chemist—Paper-pulp Dyeing—Point Lace—Power-loom Weaving—Printing Inks—Silk Throwing—Smoke Prevention—Soaps—Spinning—Textile (Spinning, Designing, Dyeing, Weaving, Finishing)—Textile Materials—Textile Fabrics—Textile Fibres—Textile Oils—Textile Soaps—Timber—Water (Industrial Uses)—Water-proofing—Weaving—Writing Inks—Yarns Testing, Sizing).

LIST III.

Architectural Terms—Brassware (Bronzing, Burnishing, Dipping, Lacquering)—Brickmaking—Building—Cement Work—Ceramic Industries—China—Coal-dust Firing—Colliery Books—Concrete—Condensing Apparatus—Dental Metallurgy—Drainage—Drugs—Dyeing—Earthenware—Electrical Books—Enamelling—Enamels—Engineering Handbooks—Evaporating Apparatus—Flint Glass-making—Foods—Food Preserving—Fruit Preserving—Gas Engines—Gas Firing—Gearing—Glassware (Painting, Riveting)—Hops—Iron (Construction, Science)—Japanning—Lead—Meat Preserving—Mines (Haulage, Electrical Equipment, Ventilation, Recovery Work from)—Plants (Diseases, Fungicides, Insecticides)—Plumbing Books—Pottery (Architectural, Clays Decorating, Manufacture, Marks on)—Reinforced Concrete—Riveting (China, Earthenware, Glassware)—Steam Turbines—Sanitary Engineering—Steel (Hardening, Tempering)—Sugar—Sweetmeats—Toothed Gearing—Vegetable Preserving—Wood Dyeing—X-Ray Work.

COPIES OF ANY OF THESE LISTS WILL BE SENT
POST FREE ON APPLICATION

(Paints, Colours, Pigments and Printing Inks.)

THE CHEMISTRY OF PIGMENTS. By ERNEST J. PARRY, B.Sc. (Lond.), F.I.C., F.C.S., and J. H. COSTE, F.I.C., F.C.S. Demy 8vo. Five Illustrations. 285 pp. Price 10s. 6d. net. (Post free, 10s. 10d. home; 11s. 3d. abroad.)

THE MANUFACTURE OF PAINT. A Practical Handbook for Paint Manufacturers, Merchants and Painters. By J. CRUICKSHANK SMITH, B.Sc. Demy 8vo. 200 pp. Sixty Illustrations and One Large Diagram. Price 7s. 6d. net. (Post free, 7s. 10d. home; 8s. abroad.)

DICTIONARY OF CHEMICALS AND RAW PRODUCTS USED IN THE MANUFACTURE OF PAINTS, COLOURS, VARNISHES AND ALLIED PREPARATIONS. By GEORGE H. HURST, F.C.S. Demy 8vo. 380 pp. Price 7s. 6d. net. (Post free, 8s. home; 8s. 6d. abroad.)

THE MANUFACTURE OF LAKE PIGMENTS FROM ARTIFICIAL COLOURS. By FRANCIS H. JENNISON, F.I.C., F.C.S. **Sixteen Coloured Plates, showing Specimens of Eighty-nine Colours, specially prepared from the Recipes given in the Book.** 136 pp. Demy 8vo. Price 7s. 6d. net. (Post free, 7s. 10d. home; 8s. abroad.)

THE MANUFACTURE OF MINERAL AND LAKE PIGMENTS. Containing Directions for the Manufacture of all Artificial, Artists and Painters' Colours, Enamel, Soot and Metallic Pigments. A text-book for Manufacturers, Merchants, Artists and Painters. By Dr. JOSEF BERSCH. Translated by A. C. WRIGHT, M.A. (Oxon.), B.Sc. (Lond.). Forty-three Illustrations. 476 pp. Demy 8vo. Price 12s. 6d. net. (Post free, 13s. home; 13s. 6d. abroad.)

RECIPES FOR THE COLOUR, PAINT, VARNISH, OIL, SOAP AND DRY-SALTERY TRADES. Compiled by AN ANALYTICAL CHEMIST. 330 pp. Second Revised and Enlarged Edition. Demy 8vo. Price 10s. 6d. net. (Post free, 11s. home; 11s. 3d. abroad.) *[Just published.]*

OILMEN'S SUNDRIES AND HOW TO MAKE THEM. Being a Collection of Practical Recipes for Boot Polishes, Blues, Metal Polishes, Disinfectants, etc., compiled from "Oils, Colours and Drysalteries". Crown 8vo. 130 pages. Price 2s. 6d. net. (Post free, 2s. 9d. home; 2s. 10d. abroad.)

OIL COLOURS AND PRINTERS' INKS. By LOUIS EDGAR ANDÉS. Translated from the German. 215 pp. Crown 8vo. 56 Illustrations. Price 5s. net. (Post free, 5s. 4d. home; 5s. 6d. abroad.)

MODERN PRINTING INKS. A Practical Handbook for Printing Ink Manufacturers and Printers. By ALFRED SEYMOUR. Demy 8vo. Six Illustrations. 90 pages. Price 5s. net. (Post free, 5s. 4d. home; 5s. 6d. abroad.)

THREE HUNDRED SHADES AND HOW TO MIX THEM. For Architects, Painters and Decorators. By A. DESAINT, Artistic Interior Decorator of Paris. The book contains 100 folio Plates, measuring 12 in. by 7 in., each Plate containing specimens of three artistic shades. These shades are all numbered, and their composition and particulars for mixing are fully given at the beginning of the book. Each Plate is interleaved with grease-proof paper, and the volume is very artistically bound in art and linen with the Shield of the Painters' Guild impressed on the cover in gold and silver. Price 21s. net. (Post free, 21s. 6d. home; 22s. 6d. abroad.)

HOUSE DECORATING AND PAINTING. By W. NORMAN BROWN. Eighty-eight Illustrations. 150 pp. Crown 8vo. Price 3s. 6d. net. (Post free, 3s. 9d. home and abroad.)

A HISTORY OF DECORATIVE ART. By W. NORMAN BROWN. Thirty-nine Illustrations. 96 pp. Crown 8vo. Price 1s. net. (Post free, 1s. 3d. home and abroad.)

WORKSHOP WRINKLES for Decorators, Painters, Paperhangers, and Others. By W. N. BROWN. Crown 8vo. 128 pp. Second Edition. Price 2s. 6d. net. (Post free, 2s. 9d. home; 2s. 10d. abroad.)

CASEIN. By ROBERT SCHERER. Translated from the German by CHAS. SALTER. Demy 8vo. Illustrated. Second Revised English Edition. 160 pp. Price 7s. 6d. net. (Post free, 7s. 10d. home; 8s. abroad.)

SIMPLE METHODS FOR TESTING PAINTERS' MATERIALS. By A. C. WRIGHT, M.A. (Oxon.), B.Sc. (Lond.). Crown 8vo. 160 pp. Price 5s. net. (Post free, 5s. 3d. home; 5s. 6d. abroad.)

IRON-CORROSION, ANTI-FOULING AND ANTI-CORROSIVE PAINTS. Translated from the German of LOUIS EDGAR ANDÉS. Sixty-two Illustrations. 275 pp. Demy 8vo. Price 10s. 6d. net. (Post free, 10s. 10d. home; 11s. 3d. abroad.)

THE TESTING AND VALUATION OF RAW MATERIALS USED IN PAINT AND COLOUR MANUFACTURE. By M. W. JONES, F.C.S. A Book for the Laboratories of Colour Works. 88 pp. Crown 8vo. Price 5s. net. (Post free, 5s. 3d. home and abroad.)

For contents of these books, see List I.

THE MANUFACTURE AND COMPARATIVE MERITS OF WHITE LEAD AND ZINC WHITE PAINTS. By G. PETIT, Civil Engineer, etc. Translated from the French. Crown 8vo. 100 pp. Price 4s. net. (Post free, 4s. 3d. home ; 4s. 4d. abroad.)

STUDENTS' HANDBOOK OF PAINTS, COLOURS, OILS AND VARNISHES. By JOHN FURNELL. Crown 8vo. 12 Illustrations. 96 pp. Price 2s. 6d. net. (Post free, 2s. 9d. home and abroad.)

PREPARATION AND USES OF WHITE ZINC PAINTS. Translated from the French of P. FLEURY. Crown 8vo. 280 pages. Price 6s. net. (Post free, 6s. 4d. home ; 6s. 6d. abroad.) [*Just published.*]

(Varnishes and Drying Oils.)

THE MANUFACTURE OF VARNISHES AND KINDRED INDUSTRIES. By J. GEDDES McINTOSH. Second, greatly enlarged, English Edition, in three Volumes, based on and including the work of Ach. Livache.

VOLUME I.—OIL CRUSHING, REFINING AND BOILING, THE MANUFACTURE OF LINO-LEUM, PRINTING AND LITHOGRAPHIC INKS, AND INDIA-RUBBER SUBSTITUTES. Demy 8vo. 150 pp. 29 Illustrations. Price 7s. 6d. net. (Post free, 7s. 10d. home ; 8s. abroad.)

VOLUME II.—VARNISH MATERIALS AND OIL-VARNISH MAKING. Demy 8vo. 70 Illustrations. 220 pp. Price 10s. 6d. net. (Post free, 10s. 10d. home ; 11s. 3d. abroad.)

VOLUME III.—SPIRIT VARNISHES AND SPIRIT VARNISH MATERIALS. Demy 8vo. Illustrated. 464 pp. Price 12s. 6d. net. (Post free, 13s. home ; 13s. 6d. abroad.)

DRYING OILS, BOILED OIL AND SOLID AND LIQUID DRIERS. By L. E. ANDÉS. Expressly Written for this Series of Special Technical Books, and the Publishers hold the Copyright for English and Foreign Editions. Forty-two Illustrations. 342 pp. Demy 8vo. Price 12s. 6d. net. (Post free, 13s. home ; 13s. 3d. abroad.)

(*Analysis of Resins, see page 9.*)

(Oils, Fats, Waxes, Greases, Petroleum.)

LUBRICATING OILS, FATS AND GREASES :

Their Origin, Preparation, Properties, Uses and Analyses. A Handbook for Oil Manufacturers, Refiners and Merchants, and the Oil and Fat Industry in General. By GEORGE H. HURST, F.C.S. Third Revised and Enlarged Edition. Seventy-four Illustrations. 384 pp. Demy 8vo. Price 10s. 6d. net. (Post free, 11s. home ; 11s. 3d. abroad.)

TECHNOLOGY OF PETROLEUM :

Oil Fields of the World—Their History, Geography and Geology—Annual Production and Development—Oil-well Drilling—Transport. By HENRY NEUBERGER and HENRY NOALHAT. Translated from the French by J. G. McINTOSH. 550 pp. 153 Illustrations. 26 Plates. Super Royal 8vo. Price 21s. net. (Post free, 21s. 9d. home ; 23s. 6d. abroad.)

MINERAL WAXES :

Their Preparation and Uses. By RUDOLF GREGORIUS. Translated from the German. Crown 8vo. 250 pp. 32 Illustrations. Price 6s. net. (Post free, 6s. 4d. home ; 6s. 6d. abroad.)

THE PRACTICAL COMPOUNDING OF OILS, TALLOW AND GREASE FOR LUBRICATION, ETC.

By AN EXPERT OIL REFINER. Second Edition. 100 pp. Demy 8vo. Price 7s. 6d. net. (Post free, 7s. 10d. home ; 8s. abroad.)

THE MANUFACTURE OF LUBRICANTS, SHOE POLISHES AND LEATHER DRESSINGS.

By RICHARD BRUNNER. Translated from the Sixth German Edition by CHAS. SALTER. 10 Illustrations. Crown 8vo. 170 pp. Price 7s. 6d. net. (Post free, 7s. 10d. home ; 8s. abroad.)

THE OIL MERCHANTS' MANUAL AND OIL TRADE READY RECKONER.

Compiled by FRANK F. SHERRIFF. Second Edition Revised and Enlarged. Demy 8vo. 214 pp. With Two Sheets of Tables. Price 7s. 6d. net. (Post free, 7s. 10d. home ; 8s. 3d. abroad.)

ANIMAL FATS AND OILS :

Their Practical Production, Purification and Uses for a great Variety of Purposes. Their Properties, Falsification and Examination. Translated from the German of LOUIS EDGAR ANDÉS. Sixty-two Illustrations. 240 pp. Second Edition, Revised and Enlarged. Demy 8vo. Price 10s. 6d. net. (Post free, 10s. 10d. home ; 11s. 3d. abroad.)

For contents of these books, see List I.

VEGETABLE FATS AND OILS: Their Practical Preparation, Purification and Employment for Various Purposes, their Properties, Adulteration and Examination. Translated from the German of LOUIS EDGAR ANDÉS. Ninety-four Illustrations. 340 pp. Second Edition. Demy 8vo. Price 10s. 6d. net. (Post free, 11s. home; 11s. 6d. abroad.)

EDIBLE FATS AND OILS: Their Composition, Manufacture and Analysis. By W. H. SIMMONS, B.Sc. (Lond.), and C. A. MITCHELL, B.A. (Oxon.). Demy 8vo. 150 pp. Price 7s. 6d. net. (Post free, 7s. 9d. home; 8s. abroad.)

(Essential Oils and Perfumes.)

THE CHEMISTRY OF ESSENTIAL OILS AND ARTIFICIAL PERFUMES. By ERNEST J. PARRY, B.Sc. (Lond.), F.I.C., F.C.S. Second Edition, Revised and Enlarged. 552 pp. 20 Illustrations. Demy 8vo. Price 12s. 6d. net. (Post free, 13s. home; 13s. 6d. abroad.)

(Soap Manufacture.)

SOAPS. A Practical Manual of the Manufacture of Domestic, Toilet and other Soaps. By GEORGE H. HURST, F.C.S. 2nd edition. 390 pp. 66 Illustrations. Demy 8vo. Price 12s. 6d. net. (Post free, 13s. home; 13s. 6d. abroad.)

TEXTILE SOAPS AND OILS. Handbook on the Preparation, Properties and Analysis of the Soaps and Oils used in Textile Manufacturing, Dyeing and Printing. By GEORGE H. HURST, F.C.S. Crown 8vo. 195 pp. 1904. Price 5s. net. (Post free, 5s. 4d. home; 5s. 6d. abroad.)

THE HANDBOOK OF SOAP MANUFACTURE. By WM. H. SIMMONS, B.Sc. (Lond.), F.C.S. and H. A. APPLETON. Demy 8vo. 160 pp. 27 Illustrations. Price 8s. 6d. net. (Post free, 8s. 10d. home; 9s. abroad.)

MANUAL OF TOILET SOAPMAKING, including Medicated Soaps, Stain-removing Soaps, Metal Polishing Soaps, Soap Powders and Detergents. Translated from the German of Dr. C. Deite. Demy quarto. 150 pages. 79 Illustrations. Price 12s. 6d. net. (Post free, 13s. home; 13s. 6d. abroad.)

(Cosmetical Preparations.)

COSMETICS: MANUFACTURE, EMPLOYMENT AND TESTING OF ALL COSMETIC MATERIALS AND COSMETIC SPECIALITIES. Translated from the German of Dr. THEODOR KOLLER. Crown 8vo. 262 pp. Price 5s. net. (Post free, 5s. 4d. home; 5s. 6d. abroad.)

(Glue, Bone Products and Manures.)

GLUE AND GLUE TESTING. By SAMUEL RIDEAL, D.Sc. (Lond.), F.I.C. Fourteen Engravings. 144 pp. Demy 8vo. Price 10s. 6d. net. (Post free, 10s. 10d. home ; 11s. abroad.)

BONE PRODUCTS AND MANURES: An Account of the most recent Improvements in the Manufacture of Fat, Glue, Animal Charcoal, Size, Gelatine and Manures. By THOMAS LAMBERT, Technical and Consulting Chemist. Illustrated by Twenty-one Plans and Diagrams. 162 pp. Demy 8vo. Price 7s. 6d. net. (Post free, 7s. 10d. home ; 8s. abroad.)

(See also *Chemical Manures*, p. 9.)

(Chemicals, Waste Products, etc.)

REISSUE OF CHEMICAL ESSAYS OF C. W. SCHEELE. First Published in English in 1786. Translated from the Academy of Sciences at Stockholm, with Additions. 300 pp. Demy 8vo. Price 5s. net. (Post free, 5s. 6d. home ; 5s. 9d. abroad.)

THE MANUFACTURE OF ALUM AND THE SULPHATES AND OTHER SALTS OF ALUMINA AND IRON. Their Uses and Applications as Mordants in Dyeing and Calico-Printing, and their other Applications in the Arts Manufactures, Sanitary Engineering, Agriculture and Horticulture. Translated from the French of LUCIEN GESCHWIND. 195 Illustrations. 400 pp. Royal 8vo. Price 12s. 6d. net. (Post free, 13s. home ; 13s. 6d. abroad.)

AMMONIA AND ITS COMPOUNDS: Their Manufacture and Uses. By CAMILLE VINCENT, Professor at the Central School of Arts and Manufactures, Paris. Translated from the French by M. J. SALTER. Royal 8vo. 114 pp. Thirty-two Illustrations. Price 5s. net. (Post free, 5s. 4d. home ; 5s. 6d. abroad.)

CHEMICAL WORKS: Their Design, Erection, and Equipment. By S. S. DYSON and S. S. CLARKSON. Royal 8vo. 220 pp. With 9 Folding Plates and 40 Illustrations. Price 21s. net. (Post free, 21s. 6d. home ; 22s. abroad.)

MANUAL OF CHEMICAL ANALYSIS, as applied to the Assay of Fuels, Ores, Metals, Alloys, Salts and other Mineral Products. By E. PROST, D.Sc. Translated by J. CRUICKSHANK SMITH, B.Sc. Royal 8vo. 300 pages. 44 Illustrations. Price 12s. 6d. net. (Post free, 13s. home ; 13s. 6d. abroad.)

TESTING OF CHEMICAL REAGENTS FOR PURITY. Translated from the German of Dr. C. KRAUCH. Royal 8vo. 350 pages. Price 12s. 6d. net. (Post free 13s. home ; 13s. 6d. abroad.)

For contents of these books, see List I.

SHALE OILS AND TARS and their Products. By Dr. W. SCHEITHAUER. Translated from the German. Demy 8vo. 190 pages. 70 Illustrations and 4 Diagrams. Price 8s. 6d. net. (Post free, 8s. 10d. home; 9s. abroad.) [*Just published.*]

INDUSTRIAL ALCOHOL. A Practical Manual on the Production and Use of Alcohol for Industrial Purposes and for Use as a Heating Agent, as an Illuminant and as a Source of Motive Power. By J. G. McINTOSH, Lecturer on Manufacture and Applications of Industrial Alcohol at The Polytechnic, Regent Street, London. Demy 8vo. 1907. 250 pp. With 75 Illustrations and 25 Tables. Price 7s. 6d. net. (Post free, 7s. 9d. home; 8s. abroad.)

THE UTILISATION OF WASTE PRODUCTS. A Treatise on the Rational Utilisation, Recovery and Treatment of Waste Products of all kinds. By Dr. THEODOR KOLLER. Translated from the Second Revised German Edition. Twenty-two Illustrations. Demy 8vo. 280 pp. Price 7s. 6d. net. (Post free, 7s. 10d. home; 8s. 3d. abroad.)

ANALYSIS OF RESINS AND BALSAMS. Translated from the German of Dr. KARL DIETERICH. Demy 8vo. 340 pp. Price 7s. 6d. net. (Post free, 7s. 10d. home; 8s. 3d. abroad.)

DISTILLATION OF RESINS, RESINATE LAKES AND PIGMENTS, CARBON PIGMENTS AND PIGMENTS FOR TYPEWRITING MACHINES, MANIFOLDERS, ETC. By VICTOR SCHWEIZER. Demy 8vo. 185 pages. 68 Illustrations. Price 7s. 6d. net. (Post free, 8s. home; 8s. 3d. abroad.)

DISINFECTION AND DISINFECTANTS. By Dr. M. CHRISTIAN. Crown 8vo. [*In the press.*]

(Agricultural Chemistry and Manures.)

MANUAL OF AGRICULTURAL CHEMISTRY. By HERBERT INGLE, F.I.C., Late Lecturer on Agricultural Chemistry, the Leeds University; Lecturer in the Victoria University. Third and Revised Edition. 400 pp. 16 Illustrations. Demy 8vo. Price 7s. 6d. net. (Post free, 8s. home; 8s. 6d. abroad.) [*Just published.*]

CHEMICAL MANURES. Translated from the French of J. FRITSCH. Demy 8vo. Illustrated. 340 pp. Price 10s. 6d. net. (Post free, 11s. home; 11s. 6d. abroad.)

(See also *Bone Products and Manures*, p. 8.)

(Writing Inks and Sealing Waxes.)

INK MANUFACTURE: Including Writing, Copying Lithographic, Marking, Stamping, and Laundry Inks. By SIGMUND LEHNER. Three Illustrations. Crown 8vo. 162 pp. Translated from the German of the Fifth Edition. Price 5s. net. (Post free, 5s. 3d. home; 5s. 6d. abroad.)

SEALING - WAXES, WAFERS AND OTHER ADHESIVES FOR THE HOUSEHOLD, OFFICE, WORKSHOP AND FACTORY. By H. C. STANDAGE. Crown 8vo. 96 pp. Price 5s. net. (Post free, 5s. 3d. home; 5s. 4d. abroad.)

(Lead Ores and Lead Compounds.)

LEAD AND ITS COMPOUNDS. By THOS. LAMBERT, Technical and Consulting Chemist. Demy 8vo. 226 pp. Forty Illustrations. Price 7s. 6d. net. (Post free, 7s. 10d. home; 8s. 3d. abroad.)

NOTES ON LEAD ORES: Their Distribution and Properties. By JAS. FAIRIE, F.G.S. Crown 8vo. 64 pages. Price 1s. net. (Post free, 1s. 3d. home; 1s. 4d. abroad.)

(*White Lead and Zinc White Paints, see p. 5.*)

(Industrial Hygiene.)

THE RISKS AND DANGERS TO HEALTH OF VARIOUS OCCUPATIONS AND THEIR PREVENTION. By LEONARD A. PARRY, M.D., B.Sc. (Lond.). 196 pp. Demy 8vo. Price 7s. 6d. net. (Post free, 7s. 10d. home; 8s. abroad.)

(Industrial Uses of Air, Steam and Water.)

DRYING BY MEANS OF AIR AND STEAM. Explanations, Formulæ, and Tables for Use in Practice. Translated from the German of E. HAUSBRAND. Two folding Diagrams and Thirteen Tables. Crown 8vo. 72 pp. Price 5s. net. (Post free, 5s. 3d. home; 5s. 6d. abroad.)

(*See also "Evaporating, Condensing and Cooling Apparatus," p. 19.*)

PURE AIR, OZONE, AND WATER. A Practical Treatise of their Utilisation and Value in Oil, Grease, Soap, Paint, Glue and other Industries. By W. B. COWELL. Twelve Illustrations. Crown 8vo. 85 pp. Price 5s. net. (Post free, 5s. 3d. home; 5s. 6d. abroad.)

THE INDUSTRIAL USES OF WATER. COMPOSITION—EFFECTS—TROUBLES—REMEDIES—RESIDUARY WATERS—PURIFICATION—ANALYSIS. By H. DE LA COUX. Royal 8vo. Translated from the French and Revised by ARTHUR MORRIS. 364 pp. 135 Illustrations. Price 10s. 6d. net. (Post free, 11s. home; 11s. 6d. abroad.)

(*See Books on Smoke Prevention, Engineering and Metallurgy, p. 19, etc.*)

For contents of these books, see List III.

(X Rays.)

PRACTICAL X RAY WORK. By FRANK T. ADDYMAN, B.Sc. (Lond.), F.I.C., Member of the Roentgen Society of London; Radiographer to St. George's Hospital; Demonstrator of Physics and Chemistry, and Teacher of Radiography in St. George's Hospital Medical School. Demy 8vo. Twelve Plates from Photographs of X Ray Work. Fifty-two Illustrations. 200 pp. Price 10s. 6d. net. (Post free, 10s. 10d. home; 11s. 3d. abroad.)

(India-Rubber and Gutta Percha.)

INDIA-RUBBER AND GUTTA PERCHA. Second English Edition, Revised and Enlarged. Based on the French work of T. SEELIGMANN, G. LAMY TORRILHON and H. FALCONNET by JOHN GEDDES MCINTOSH. Royal 8vo. 100 Illustrations. 400 pages. Price 12s. 6d. net. (Post free, 13s. home; 13s. 6d. abroad.)

(Leather Trades.)

THE LEATHER WORKER'S MANUAL. Being a Compendium of Practical Recipes and Working Formulæ for Curriers, Bootmakers, Leather Dressers, Blacking Manufacturers, Saddlers, Fancy Leather Workers. By H. C. STANDAGE. Demy 8vo. 165 pp. Price 7s. 6d. net. (Post free, 7s. 10d. home; 8s. abroad.)

(See also *Manufacture of Shoe Polishes, Leather Dressings, etc.*, p. 6.)

(Pottery, Bricks, Tiles, Glass, etc.)

MODERN BRICKMAKING. By ALFRED B. SEARLE, Royal 8vo. 440 pages. 260 Illustrations. Price 12s. 6d. net. (Post free, 13s. home; 13s. 6d. abroad.)

THE MANUAL OF PRACTICAL POTTING. Compiled by Experts, and Edited by CHAS. F. BINNS. Third Edition, Revised and Enlarged. 200 pp. Demy 8vo. Price 17s. 6d. net. (Post free, 17s. 10d. home; 18s. 3d. abroad.)

POTTERY DECORATING. A Description of all the Processes for Decorating Pottery and Porcelain. By R. HAINBACH. Translated from the German. Crown 8vo. 250 pp. Twenty-two Illustrations. Price 7s. 6d. net. (Post free, 7s. 10d. home; 8s. abroad.)

A TREATISE ON CERAMIC INDUSTRIES. A Complete Manual for Pottery, Tile, and Brick Manufacturers. By EMILE BOURRY. A Revised Translation from the French, with some Critical Notes by ALFRED B. SEARLE. Demy 8vo. 308 Illustrations. 460 pp. Price 12s. 6d. net. (Post free, 13s. home; 13s. 6d. abroad.)

ARCHITECTURAL POTTERY. Bricks, Tiles, Pipes, Enamelled Terra-cottas, Ordinary and Incrusted Quarries, Stoneware Mosaics, Faïences and Architectural Stoneware. By LEON LEFÈVRE. Translated from the French by K. H. BIRD, M.A., and W. MOORE BINNS. With Five Plates. 950 Illustrations in the Text, and numerous estimates. 500 pp., royal 8vo. Price 15s. net. (Post free, 15s. 6d. home; 16s. 6d. abroad.)

CERAMIC TECHNOLOGY: Being some Aspects of Technical Science as Applied to Pottery Manufacture. Edited by CHARLES F. BINNS. 100 pp. Demy 8vo. Price 12s. 6d. net. (Post free, 12s. 10d. home; 13s. abroad.)

THE ART OF RIVETING GLASS, CHINA AND EARTHENWARE. By J. HOWARTH. Second Edition. Paper Cover. Price 1s. net. (By post, home or abroad, 1s. 1d.)

NOTES ON POTTERY CLAYS. The Distribution, Properties, Uses and Analyses of Ball Clays, China Clays and China Stone. By JAS. FAIRIE, F.G.S. 132 pp. Crown 8vo. Price 3s. 6d. net. (Post free, 3s. 9d. home; 3s. 10d. abroad.)

HOW TO ANALYSE CLAY. By H. M. Ashby. Demy 8vo. 72 Pages. 20 Illustrations. Price 3s. 6d. net. (Post free, 3s. 9d. home; 3s. 10d. abroad.)

A Reissue of

THE HISTORY OF THE STAFFORDSHIRE POTTERIES; AND THE RISE AND PROGRESS OF THE MANUFACTURE OF POTTERY AND PORCELAIN. With References to Genuine Specimens, and Notices of Eminent Potters. By SIMEON SHAW. (Originally published in 1829.) 265 pp. Demy 8vo. Price 5s. net. (Post free, 5s. 4d. home; 5s. 9d. abroad.)

A Reissue of

THE CHEMISTRY OF THE SEVERAL NATURAL AND ARTIFICIAL HETEROGENEOUS COMPOUNDS USED IN MANUFACTURING PORCELAIN, GLASS AND POTTERY. By SIMEON SHAW. (Originally published in 1837.) 750 pp. Royal 8vo. Price 10s. net. (Post free, 10s. 6d. home; 12s. abroad.)

BRITISH POTTERY MARKS. By G. WOOLLISCROFT RHEAD. Demy 8vo. 310 pp. With over Twelve-hundred Illustrations of Marks. Price 7s. 6d. net. (Post free, 8s. home; 8s. 3d. abroad.)

For contents of these books, see List III.

(Glassware, Glass Staining and Painting.)

RECIPES FOR FLINT GLASS MAKING. By a British Glass Master and Mixer. Sixty Recipes. Being Leaves from the Mixing Book of several experts in the Flint Glass Trade, containing up-to-date recipes and valuable information as to Crystal, Demi-crystal and Coloured Glass in its many varieties. It contains the recipes for cheap metal suited to pressing, blowing, etc., as well as the most costly crystal and ruby. Second Edition. Crown 8vo. Price 10s. 6d. net. (Post free, 10s. 9d. home; 10s. 10d. abroad.)

A TREATISE ON THE ART OF GLASS PAINTING. Prefaced with a Review of Ancient Glass. By ERNEST R. SUFFLING. With One Coloured Plate and Thirty-seven Illustrations. Demy 8vo. 140 pp. Price 7s. 6d. net. (Post free, 7s. 10d. home; 8s. abroad.)

(Paper Making, Paper Dyeing, and Testing.)

THE DYEING OF PAPER PULP. A Practical Treatise for the use of Papermakers, Paperstainers, Students and others. By JULIUS ERFURT, Manager of a Paper Mill. Translated into English and Edited with Additions by JULIUS HÜBNER, F.C.S., Lecturer on Papermaking at the Manchester Municipal Technical School. With illustrations and **157 patterns of paper dyed in the pulp.** Royal 8vo, 180 pp. Price 15s. net. (Post free, 15s. 6d. home; 16s. 6d. abroad.)

THE PAPER MILL CHEMIST. By HENRY P. STEVENS, M.A., Ph.D., F.I.C. Royal 12mo. 60 illustrations. 300 pp. Price 7s. 6d. net. (Post free, 7s. 9d. home; 7s. 10d. abroad.)

THE TREATMENT OF PAPER FOR SPECIAL PURPOSES. By L. E. ANDÉS. Translated from the German. Crown 8vo. 48 Illustrations. 250 pp. Price 6s. net. (Post free, 6s. 4d. home; 6s. 6d. abroad.)

(Enamelling on Metal.)

ENAMELS AND ENAMELLING. For Enamel Makers, Workers in Gold and Silver, and Manufacturers of Objects of Art. By PAUL RANDAU. Second and Revised Edition. Translated from the German. With 16 Illustrations. Demy 8vo. 180 pp. Price 10s. 6d. net. (Post free, 10s. 10d. home; 11s. abroad.) [*Just published.*]

THE ART OF ENAMELLING ON METAL. By W. NORMAN BROWN. Twenty-eight Illustrations. Crown 8vo. 60 pp. Price 2s. 6d. net. (Post free, 2s. 9d. home and abroad.)

(Textile and Dyeing Subjects.)

THE FINISHING OF TEXTILE FABRICS (Woollen, Worsted, Union and other Cloths). By ROBERTS BEAUMONT, M.Sc., M.I.Mech.E., Professor of Textile Industries, the University of Leeds; Author of "Colour in Woven Design"; "Woollen and Worsted Cloth Manufacture"; "Woven Fabrics at the World's Fair"; Vice-President of the Jury of Award at the Paris Exhibition, 1900; Inspector of Textile Institutes; Society of Arts Silver Medallist; Honorary Medallist of the City and Guilds of London Institute. With 150 Illustrations of Fibres, Yarns and Fabrics, also Sectional and other Drawings of Finishing Machinery. Demy 8vo. 260 pp. Price 10s. 6d. net. (Post free, 10s. 10d. home; 11s. 3d. abroad.)

FIBRES USED IN TEXTILE AND ALLIED INDUSTRIES. By C. AINSWORTH MITCHELL, B.A. (Oxon.), F.I.C., and R. M. PRIDEAUX, F.I.C. With 66 Illustrations specially drawn direct from the Fibres. Demy 8vo. 200 pp. Price 7s. 6d. net. (Post free, 7s. 10d. home; 8s. abroad.)

DRESSINGS AND FINISHINGS FOR TEXTILE FABRICS AND THEIR APPLICATION. Description of all the Materials used in Dressing Textiles: Their Special Properties, the preparation of Dressings and their employment in Finishing Linen, Cotton, Woollen and Silk Fabrics. Fireproof and Waterproof Dressings, together with the principal machinery employed. Translated from the Third German Edition of FRIEDRICH POLLEYN. Demy 8vo. 280 pp. Sixty Illustrations. Price 7s. 6d. net. (Post free, 7s. 10d. home; 8s. abroad.)

THE CHEMICAL TECHNOLOGY OF TEXTILE FIBRES: Their Origin, Structure, Preparation, Washing, Bleaching, Dyeing, Printing and Dressing. By Dr. GEORG VON GEORGIEVICS. Translated from the German by CHARLES SALTER. 320 pp. Forty-seven Illustrations. Royal 8vo. Price 10s. 6d. net. (Post free, 11s. home; 11s. 3d. abroad.)

POWER-LOOM WEAVING AND YARN NUMBERING, According to Various Systems, with Conversion Tables. Translated from the German of ANTHON GRUNER. With **Twenty-six Diagrams in Colours.** 150 pp. Crown 8vo. Price 7s. 6d. net. (Post free, 7s. 9d. home; 8s. abroad.)

TEXTILE RAW MATERIALS AND THEIR CONVERSION INTO YARNS. (The Study of the Raw Materials and the Technology of the Spinning Process.) By JULIUS ZIPSER. Translated from German by CHARLES SALTER. 302 Illustrations. 500 pp. Demy 8vo. Price 10s. 6d. net. (Post free, 11s. home; 11s. 6d. abroad.)

For contents of these books, see List II.

GRAMMAR OF TEXTILE DESIGN. By H. NISBET, Weaving and Designing Master, Bolton Municipal Technical School. Demy 8vo. 280 pp. 490 Illustrations and Diagrams. Price 6s. net. (Post free, 6s. 4d. home; 6s. 6d. abroad.)

ART NEEDLEWORK AND DESIGN. POINT LACE. A Manual of Applied Art for Secondary Schools and Continuation Classes. By M. E. WILKINSON. Oblong quarto. With 22 Plates. Bound in Art Linen. Price 3s. 6d. net. (Post free, 3s. 10d. home; 4s. abroad.)

HOME LACE-MAKING. A Handbook for Teachers and Pupils. By M. E. W. MILROY. Crown 8vo. 64 pp. With 3 Plates and 9 Diagrams. Price 1s. net. (Post free, 1s. 3d. home; 1s. 4d. abroad.)

THE CHEMISTRY OF HAT MANUFACTURING. Lectures delivered before the Hat Manufacturers' Association. By WATSON SMITH, F.C.S., F.I.C. Revised and Edited by ALBERT SHONK. Crown 8vo. 132 pp. 16 Illustrations. Price 7s. 6d. net. (Post free, 7s. 9d. home; 7s. 10d. abroad.)

THE TECHNICAL TESTING OF YARNS AND TEXTILE FABRICS. With Reference to Official Specifications. Translated from the German of Dr. J. HERZFELD. Second Edition. Sixty-nine Illustrations. 200 pp. Demy 8vo. Price 10s. 6d. net. (Post free, 10s. 10d. home; 11s. abroad.)

DECORATIVE AND FANCY TEXTILE FABRICS. By R. T. LORD. For Manufacturers and Designers of Carpets, Damask, Dress and all Textile Fabrics. 200 pp. Demy 8vo. 132 Designs and Illustrations. Price 7s. 6d. net. (Post free, 7s. 10d. home; 8s. abroad.)

THEORY AND PRACTICE OF DAMASK WEAVING. By H. KINZER and K. WALTER. Royal 8vo. Eighteen Folding Plates. Six Illustrations. Translated from the German. 110 pp. Price 8s. 6d. net. (Post free, 9s. home; 9s. 6d. abroad.)

FAULTS IN THE MANUFACTURE OF WOOLLEN GOODS AND THEIR PREVENTION. By NICOLAS REISER. Translated from the Second German Edition. Crown 8vo. Sixty-three Illustrations. 170 pp. Price 5s. net. (Post free, 5s. 4d. home; 5s. 6d. abroad.)

SPINNING AND WEAVING CALCULATIONS, especially relating to Woollens. From the German of N. REISER. Thirty-four Illustrations. Tables. 160 pp. Demy 8vo. 1904. Price 10s. 6d. net. (Post free, 10s. 10d. home; 11s. abroad.)

ANALYSIS OF WOVEN FABRICS. By A. F. BARKER and E. MIDGLEY. Demy 8vo. About 200 pages [*In the press.*]

WATERPROOFING OF FABRICS. By Dr. S. MIERZINSKI. Crown 8vo. 104 pp. 29 Illus. Price 5s. net. (Post free, 5s. 3d. home; 5s. 4d. abroad.)

HOW TO MAKE A WOOLLEN MILL PAY. By JOHN MACKIE. Crown 8vo. 76 pp. Price 3s. 6d. net. (Post free, 3s. 9d. home; 3s. 10d. abroad.)

YARN AND WARP SIZING IN ALL ITS BRANCHES. Translated from the German of CARL KRETSCHMAR. Royal 8vo. 123 Illustrations. 150 pp. Price 10s. 6d. net. (Post free, 10s. 10d. home; 11s. abroad.)

(For "*Textile Soaps and Oils*" see p. 7.)

(Dyeing, Colour Printing, Matching and Dye-stuffs.)

THE COLOUR PRINTING OF CARPET YARNS. Manual for Colour Chemists and Textile Printers. By DAVID PATERSON, F.C.S. Seventeen Illustrations. 136 pp. Demy 8vo. Price 7s. 6d. net. (Post free, 7s. 10d. home; 8s. abroad.)

THE SCIENCE OF COLOUR MIXING. A Manual intended for the use of Dyers, Calico Printers and Colour Chemists. By DAVID PATERSON, F.C.S. Forty-one Illustrations. **Five Coloured Plates, and Four Plates showing Eleven Dyed Specimens of Fabrics.** 132 pp. Demy 8vo. Price 7s. 6d. net. (Post free, 7s. 10d. home; 8s. abroad.)

DYERS' MATERIALS : An Introduction to the Examination, Evaluation and Application of the most important Substances used in Dyeing, Printing, Bleaching and Finishing. By PAUL HEERMAN, Ph.D. Translated from the German by A. C. WRIGHT, M.A. (Oxon.), B.Sc. (Lond.). Twenty-four Illustrations. Crown 8vo. 150 pp. Price 5s. net. (Post free, 5s. 4d. home; 5s. 6d. abroad.)

COLOUR MATCHING ON TEXTILES. A Manual intended for the use of Students of Colour Chemistry, Dyeing and Textile Printing. By DAVID PATERSON, F.C.S. Coloured Frontispiece. Twenty-nine Illustrations and **Fourteen Specimens of Dyed Fabrics.** Demy 8vo. 132 pp. Price 7s. 6d. net. (Post free, 7s. 10d. home; 8s. abroad.)

COLOUR : A HANDBOOK OF THE THEORY OF COLOUR. By GEORGE H. HURST, F.C.S. **With Ten Coloured Plates** and Seventy-two Illustrations. 160 pp. Demy 8vo. Price 7s. 6d. net. (Post free, 7s. 10d. home; 8s. abroad.)

For contents of these books, see List II.

Reissue of

THE ART OF DYEING WOOL, SILK AND COTTON. Translated from the French of M. HELLOT, M. MACQUER and M. LE PILEUR D'APLIGNY. First Published in English in 1789. Six Plates. Demy 8vo. 446 pp. Price 5s. net. (Post free, 5s. 6d. home; 6s. abroad.)

THE CHEMISTRY OF DYE-STUFFS. By Dr. GEORG VON GEORGIEVICS. Translated from the Second German Edition. 412 pp. Demy 8vo. Price 10s. 6d. net. (Post free, 11s. home; 11s. 6d. abroad.)

THE DYEING OF COTTON FABRICS : A Practical Handbook for the Dyer and Student. By FRANKLIN BEECH, Practical Colourist and Chemist. 272 pp. Forty-four Illustrations of Bleaching and Dyeing Machinery. Demy 8vo. Price 7s. 6d. net. (Post free, 7s. 10d. home; 8s. abroad.)

THE DYEING OF WOOLLEN FABRICS. By FRANKLIN BEECH, Practical Colourist and Chemist. Thirty-three Illustrations. Demy 8vo. 228 pp. Price 7s. 6d. net. (Post free, 7s. 10d. home; 8s. abroad.)

(Silk Manufacture.)

SILK THROWING AND WASTE SILK SPINNING. By HOLLINS RAYNER. Demy 8vo. 170 pp. 117 Illus. Price 5s. net. (Post free, 5s. 4d. home; 5s. 6d. abroad.)

(Bleaching and Bleaching Agents.)

A PRACTICAL TREATISE ON THE BLEACHING OF LINEN AND COTTON YARN AND FABRICS. By L. TAILFER, Chemical and Mechanical Engineer. Translated from the French by JOHN GEDDES MCINTOSH. Demy 8vo. 303 pp. Twenty Illus. Price 12s. 6d. net. (Post free, 13s. home; 13s. 6d. abroad.)

MODERN BLEACHING AGENTS AND DETERGENTS. By Professor MAX BOTTLER. Translated from the German. Crown 8vo. 16 Illustrations. 160 pages. Price 5s. net. (Post free, 5s. 3d. home; 5s. 6d. abroad.)

(Cotton Spinning, Cotton Waste and Cotton Combing.)

COTTON SPINNING (First Year). By THOMAS THORNLEY, Spinning Master, Bolton Technical School. 160 pp. Eighty-four Illustrations. Crown 8vo. Second Impression. Price 3s. net. (Post free, 3s. 4d. home; 3s. 6d. abroad.)

COTTON SPINNING (Intermediate, or Second Year). By THOMAS THORNLEY. Second Impression. 180 pp. Seventy Illustrations. Crown 8vo. Price 5s. net. (Post free, 5s. 4d. home; 5s. 6d. abroad.)

COTTON SPINNING (Honours, or Third Year). By THOMAS THORNLEY. 216 pp. Seventy-four Illustrations. Crown 8vo. Second Edition. Price 5s. net. (Post free, 5s. 4d. home; 5s. 6d. abroad.)

COTTON COMBING MACHINES. By THOS. THORNLEY, Spinning Master, Technical School, Bolton. Demy 8vo. 117 Illustrations. 300 pp. Price 7s. 6d. net. (Post free, 8s. home; 8s. 6d. abroad.)

COTTON WASTE: Its Production, Characteristics, Regulation, Opening, Carding, Spinning and Weaving. By THOMAS THORNLEY. Demy 8vo. 286 pages. 60 Illustrations. Price 7s. 6d. net. (Post free, 7s. 10d. home; 8s. abroad.) [*Just published.*]

THE RING SPINNING FRAME: GUIDE FOR OVERLOOKERS AND STUDENTS. By N. BOOTH. Crown 8vo. 76 pages. Price 3s. net. (Post free, 3s. 3d. home; 3s. 6d. abroad.)

(Flax, Hemp and Jute Spinning.)

MODERN FLAX, HEMP AND JUTE SPINNING AND TWISTING. A Practical Handbook for the use of Flax, Hemp and Jute Spinners, Thread, Twine and Rope Makers. By HERBERT R. CARTER, Mill Manager, Textile Expert and Engineer, Examiner in Flax Spinning to the City and Guilds of London Institute. Demy 8vo. 1907. With 92 Illustrations. 200 pp. Price 7s. 6d. net. (Post free, 7s. 9d. home; 8s. abroad.)

(Collieries and Mines.)

RECOVERY WORK AFTER PIT FIRES. By ROBERT LAMPRECHT, Mining Engineer and Manager. Translated from the German. Illustrated by Six large Plates, containing Seventy-six Illustrations. 175 pp. Demy 8vo. Price 10s. 6d. net. (Post free, 10s. 10d. home; 11s. abroad.)

VENTILATION IN MINES. By ROBERT WABNER, Mining Engineer. Translated from the German. Royal 8vo. Thirty Plates and Twenty-two Illustrations. 240 pp. Price 10s. 6d. net. (Post free, 11s. home; 11s. 3d. abroad.)

HAULAGE AND WINDING APPLIANCES USED IN MINES. By CARL VOLK. Translated from the German. Royal 8vo. With Six Plates and 148 Illustrations. 150 pp. Price 8s. 6d. net. (Post free, 9s. home; 9s. 3d. abroad.)

THE ELECTRICAL EQUIPMENT OF COLLIERIES. By W. GALLOWAY DUNCAN, Electrical and Mechanical Engineer, Member of the Institution of Mining Engineers, Head of the Government School of Engineering, Dacca, India; and DAVID PENMAN, Certificated Colliery Manager, Lecturer in Mining to Fife County Committee. Demy 8vo. 310 pp. 155 Illustrations and Diagrams. Price 10s. 6d. net. (Post free, 11s. home; 11s. 3d. abroad.)

For contents of these books, see List III.

(Dental Metallurgy.)

DENTAL METALLURGY: MANUAL FOR STUDENTS AND DENTISTS. By A. B. GRIFFITHS, Ph.D. Demy 8vo. Thirty-six Illustrations. 200 pp. Price 7s. 6d. net. (Post free, 7s. 10d. home; 8s. abroad.)

(Engineering, Smoke Prevention and Metallurgy.)

THE PREVENTION OF SMOKE. Combined with the Economical Combustion of Fuel. By W. C. POPPLEWELL, M.Sc., A.M. Inst., C.E., Consulting Engineer. Forty-six Illustrations. 190 pp. Demy 8vo. Price 7s. 6d. net. (Post free, 7s. 10d. home; 8s. 3d. abroad.)

GAS AND COAL DUST FIRING. A Critical Review of the Various Appliances Patented in Germany for this purpose since 1885. By ALBERT PÜTSCH. 130 pp. Demy 8vo. Translated from the German. With 103 Illustrations. Price 5s. net. (Post free, 5s. 4d. home; 5s. 6d. abroad.)

THE HARDENING AND TEMPERING OF STEEL IN THEORY AND PRACTICE. By FRIDOLIN REISER. Translated from the German of the Third Edition. Crown 8vo. 120 pp. Price 5s. net. (Post free, 5s. 3d. home; 5s. 4d. abroad.)

SIDEROLGY: THE SCIENCE OF IRON (The Constitution of Iron Alloys and Slags). Translated from German of HANNS FREIHERR V. JÜPTNER. 350 pp. Demy 8vo. Eleven Plates and Ten Illustrations. Price 10s. 6d. net. (Post free, 11s. home; 11s. 6d. abroad.)

EVAPORATING, CONDENSING AND COOLING APPARATUS. Explanations, Formulæ and Tables for Use in Practice. By E. HAUSBRAND, Engineer. Translated by A. C. WRIGHT, M.A. (Oxon.), B.Sc., (Lond.). With Twenty-one Illustrations and Seventy-six Tables. 400 pp. Demy 8vo. Price 10s. 6d. net. (Post free, 11s. home; 11s. 6d. abroad.)

(The "Broadway" Series of Engineering Handbooks.)

One Uniform Size: Narrow Crown 8vo. (Pocket Size.)

VOLUME I.—ELEMENTARY PRINCIPLES OF REINFORCED CONCRETE CONSTRUCTION. By EWART S. ANDREWS, B.Sc. Eng. (Lond.). 200 pages. With 57 Illustrations. Numerous Tables and Worked Examples. Price 3s. net. (Post free, 3s. 3d. home; 3s. 6d. abroad.)

VOLUME II.—GAS AND OIL ENGINES. By A. KIRSCHKE. Translated and Revised from the German, and adapted to English practice. 160 pages. 55 Illustrations. Price 3s. net. (Post free, 3s. 3d. home; 3s. 6d. abroad.)

- VOLUME III.—IRON AND STEEL CONSTRUCTIONAL WORK.** By K. SCHINDLER. Translated and Revised from the German, and adapted to English practice. 140 pages. 115 Illustrations. Price 3s. 6d. net. (Post free, 3s. 9d. home; 4s. abroad.)
- VOLUME IV.—TOOTHED GEARING.** By G. T. WHITE, B.Sc. (Lond.). 220 pages. 136 Illustrations. Price 3s. 6d. net. (Post free, 3s. 9d. home; 4s. abroad.)
- VOLUME V.—STEAM TURBINES:** Their Theory and Construction. By H. WILDA. Translated and Revised from the German, and adapted to English practice. 200 pages. 104 Illustrations. Price 3s. 6d. net. (Post free, 3s. 9d. home; 4s. abroad.) *[Just published.]*
- VOLUME VI.—CRANES AND HOISTS.** By H. WILDA. *[In the press.]*
- VOLUME VII.—FOUNDRY MACHINERY.** By E. TREIBER. *[In the press.]*
- VOLUME VIII.—THE CALCULUS FOR ENGINEERS.** By EWART S. ANDREWS, B.Sc. Eng. (Lond.), and H. BRYON HEYWOOD, B.Sc. (Lond.). *[In preparation.]*
- VOLUME IX.—ILLUMINATION AND LIGHTING.** By A. BLOK, B.Sc. *[In preparation.]*
- VOLUME X.—MOTOR CAR MECHANISM.** By W. E. DOMMETT. *[In preparation.]*

(Sanitary Plumbing, Electric Wiring,
Metal Work, etc.)

- EXTERNAL PLUMBING WORK.** A Treatise on Lead Work for Roofs. By JOHN W. HART, R.P.C. 180 Illustrations. 272 pp. Demy 8vo. Second Edition Revised. Price 7s. 6d. net. (Post free, 7s. 10d. home; 8s. abroad.)
- HINTS TO PLUMBERS ON JOINT WIPING, PIPE BENDING AND LEAD BURNING.** Third Edition, Revised and Corrected, By JOHN W. HART, R.P.C. 184 Illustrations. 313 pp. Demy 8vo. Price 7s. 6d. net. (Post free, 8s. home; 8s. 6d. abroad.)
- SANITARY PLUMBING AND DRAINAGE.** By JOHN W. HART. Demy 8vo. With 208 Illustrations. 250 pp. 1904. Price 7s. 6d. net. (Post free, 7s. 10d. home; 8s. abroad.)
- ELECTRIC WIRING AND FITTING.** By SYDNEY F. WALKER, R.N., M.I.E.E., M.I.Min.E., A.M.Inst.C.E., etc. Crown 8vo. 150 pp. With Illustrations and Tables. Price 5s. net. (Post free, 5s. 3d. home; 5s. 6d. abroad.)
- THE PRINCIPLES AND PRACTICE OF DIPPING, BURNISHING, LACQUERING AND BRONZING BRASS WARE.** By W. NORMAN BROWN. 48 pp. Crown 8vo. Price 3s. net. (Post free, 3s. 3d. home and abroad.)

For contents of these books, see List III.

THE DEVELOPMENT OF THE INCANDESCENT ELECTRIC LAMP. By G. BASIL BARHAM, A.M.I.E.E.

Demy 8vo. 200 pages. 2 Plates, 25 Illustrations and 10 Tables. Price 5s. net. (Post free, 5s. 4d. home; 5s. 6d. abroad.)

[Just published.]

WIRING CALCULATIONS FOR ELECTRIC LIGHT AND POWER INSTALLATIONS. A

Practical Handbook containing Wiring Tables, Rules, and Formulæ for the Use of Architects, Engineers, Mining Engineers, and Electricians, Wiring Contractors and Wiremen, etc. By G. W. LUMMIS PATERSON. Crown 8vo. 96 pages. 35 Tables. Price 5s. net. (Post free, 5s. 3d. home; 5s. 6d. abroad.)

[Just published.]

A HANDBOOK ON JAPANING. For Ironware, Tinware, and Wood, etc. By WILLIAM NORMAN BROWN. Second Edition. 70 pages. 13 Illustrations. Crown 8vo. Price 3s. 6d. net. (Post free, 3s. 9d. home; 4s. abroad.)

[Just published.]

THE PRINCIPLES OF HOT WATER SUPPLY. By

JOHN W. HART, R.P.C. With 129 Illustrations. 177 pp. Demy 8vo. Price 7s. 6d. net. (Post free, 7s. 10d. home; 8s. abroad.)

(Brewing and Botanical.)

HOPS IN THEIR BOTANICAL, AGRICULTURAL AND TECHNICAL ASPECT, AND AS AN ARTICLE OF COMMERCE. By EMMANUEL GROSS,

Professor at the Higher Agricultural College, Tetschen-Liebwerd. Translated from the German. Seventy-eight Illustrations. 340 pp. Demy 8vo. Price 10s. 6d. net. (Post free, 11s. home; 11s. 6d. abroad.)

INSECTICIDES, FUNGICIDES AND WEED-KILLERS. By E. BOURCART, D.Sc. Translated from

the French. Revised and Adapted to British Standards and Practice. Demy 8vo. 450 pages, 83 Tables, and 12 Illustrations. Price 12s. 6d. net. (Post free, 13s. home; 13s. 6d. abroad.)

(For Agricultural Chemistry, see p. 9.)

[Just published.]

(Wood Products, Timber and Wood Waste.)

WOOD PRODUCTS: DISTILLATES AND EXTRACTS. By P. DUMESNY, Chemical Engineer,

Expert before the Lyons Commercial Tribunal, Member of the International Association of Leather Chemists; and J. NOYER. Translated from the French by DONALD GRANT. Royal 8vo. 320 pp. 103 Illustrations and Numerous Tables. Price 10s. 6d. net. (Post free, 11s. home; 11s. 6d. abroad.)

TIMBER: A Comprehensive Study of Wood in all its Aspects (Commercial and Botanical), showing the different Applications and Uses of Timber in Various Trades, etc. Translated from the French of PAUL CHARPENTIER. Royal 8vo. 437 pp. 178 Illustrations. Price 12s. 6d. net. (Post free, 13s. home; 14s. abroad.)

THE UTILISATION OF WOOD WASTE. Translated from the German of ERNST HUBBARD. Crown 8vo. 192 pp. Fifty Illustrations. Price 5s. net. (Post free, 5s. 4d. home 5s. 6d. abroad.)

(See also *Utilisation of Waste Products*, p. 9.)

(Building and Architecture.)

ORNAMENTAL CEMENT WORK. By OLIVER WHEATLEY. Demy 8vo. 83 Illustrations. 123 pp. Price 5s. net. (Post free, 5s. 4d. home; 5s. 6d. abroad.)

THE PREVENTION OF DAMPNES IN BUILDINGS; with Remarks on the Causes, Nature and Effects of Saline, Efflorescences and Dry-rot, for Architects, Builders, Overseers, Plasterers, Painters and House Owners. By ADOLF WILHELM KEIM. Translated from the German of the second revised Edition by M. J. SALTER, F.I.C., F.C.S. Eight Coloured Plates and Thirteen Illustrations. Crown 8vo. 115 pp. Price 5s. net. (Post free, 5s. 3d. home; 5s. 4d. abroad.)

HANDBOOK OF TECHNICAL TERMS USED IN ARCHITECTURE AND BUILDING, AND THEIR ALLIED TRADES AND SUBJECTS. By AUGUSTINE C. PASSMORE. Demy 8vo. 380 pp. Price 7s. 6d. net. (Post free, 8s. home; 8s. 6d. abroad.)

(Foods, Drugs and Sweetmeats.)

FOOD AND DRUGS. By E. J. PARRY, B.Sc., F.I.C., F.C.S.
Volume I. The Analysis of Food and Drugs (Chemical and Microscopical). Royal 8vo. 724 pp. Price 21s. net. (Post free, 21s. 8d. home; 22s. abroad.)
Volume II. The Sale of Food and Drugs Acts, 1875-1907. Royal 8vo. 184 pp. Price 7s. 6d. net. (Post free, 7s. 10d. home; 8s. abroad.)

THE MANUFACTURE OF PRESERVED FOODS AND SWEETMEATS. By A. HAUSNER. With Twenty-eight Illustrations. Translated from the German of the third enlarged Edition. Second English Edition. Crown 8vo. 225 pp. Price 7s. 6d. net. (Post free, 7s. 9d. home; 7s. 10d. abroad.)

RECIPES FOR THE PRESERVING OF FRUIT, VEGETABLES AND MEAT. By E. WAGNER. Translated from the German. Crown 8vo. 125 pp. With 14 Illustrations. Price 5s. net. (Post free, 5s. 3d. home; 5s. 4d. abroad.)

For contents of these books, see L st III.

(Dyeing Fancy Goods.)

THE ART OF DYEING AND STAINING MARBLE, ARTIFICIAL STONE, BONE, HORN, IVORY AND WOOD, AND OF IMITATING ALL SORTS OF WOOD. A Practical Handbook for the Use of Joiners, Turners, Manufacturers of Fancy Goods, Stick and Umbrella Makers, Comb Makers, etc. Translated from the German of D. H. SOXHLET, Technical Chemist. Crown 8vo. 168 pp. Price 5s. net. (Post free, 5s. 3d. home; 5s. 4d. abroad.)

(Celluloid.)

CELLULOID: Its Raw Material, Manufacture, Properties and Uses. A Handbook for Manufacturers of Celluloid and Celluloid Articles, and all Industries using Celluloid; also for Dentists and Teeth Specialists. By Dr. FR. BÖCKMANN, Technical Chemist. Translated from the Third Revised German Edition. Crown 8vo. 120 pp. With 49 Illustrations. Price 5s. net. (Post free, 5s. 3d. home; 5s. 4d. abroad.)

(Lithography, Printing and Engraving.)

PRACTICAL LITHOGRAPHY. By ALFRED SEYMOUR. Demy 8vo. With Frontispiece and 33 Illus. 120 pp. Price 5s. net. (Post free, 5s. 4d. home; 5s. 6d. abroad.)

PRINTERS' AND STATIONERS' READY RECKONER AND COMPENDIUM. Compiled by VICTOR GRAHAM. Crown 8vo. 112 pp. 1904. Price 3s. 6d. net. (Post free, 3s. 9d. home; 3s. 10d. abroad.)

ENGRAVING FOR ILLUSTRATION. HISTORICAL AND PRACTICAL NOTES. By J. KIRKBRIDE. 72 pp. Two Plates and 6 Illustrations. Crown 8vo. Price 2s. 6d. net. (Post free, 2s. 9d. home; 2s. 10d. abroad.)

(For Printing Inks, see p. 4.)

(Bookbinding.)

PRACTICAL BOOKBINDING. By PAUL ADAM. Translated from the German. Crown 8vo. 180 pp. 127 Illustrations. Price 5s. net. (Post free, 5s. 4d. home; 5s. 6d. abroad.)

(Sugar Refining.)

THE TECHNOLOGY OF SUGAR: Practical Treatise on the Modern Methods of Manufacture of Sugar from the Sugar Cane and Sugar Beet. By JOHN GEDDES McINTOSH. Second Revised and Enlarged Edition. Demy 8vo. Fully Illustrated. 436 pp. Seventy-six Tables. 1906. Price 10s. 6d. net. (Post free, 11s. home; 11s. 6d. abroad.)

(See "Evaporating, Condensing, etc., Apparatus," t. 9.)

(Emery.)

EMERY AND THE EMERY INDUSTRY. Translated from the German of A. HAENIG. Crown 8vo. 45 Illustrations. 104 pp. Price 5s. net. (Post free, 5s. 3d. home; 5s. 6d. abroad.)

(Libraries and Bibliography.)

CLASSIFIED GUIDE TO TECHNICAL AND COMMERCIAL BOOKS. Compiled by EDGAR GREENWOOD. Demy 8vo. 224 pp. 1904. Being a Subject-list of the Principal British and American Books in Print; giving Title, Author, Size, Date, Publisher and Price. Price 5s. net. (Post free, 5s. 4d. home; 5s. 6d. abroad.)

HANDBOOK TO THE TECHNICAL AND ART SCHOOLS AND COLLEGES OF THE UNITED KINGDOM. Containing particulars of nearly 1,000 Technical, Commercial and Art Schools throughout the United Kingdom. With full particulars of the courses of instruction, names of principals, secretaries, etc. Demy 8vo. 150 pp. Price 3s. 6d. net. (Post free, 3s. 10d. home; 4s. abroad.)

THE LIBRARIES, MUSEUMS AND ART GALLERIES YEAR BOOK, 1910-11. Being the Third Edition of Greenwood's "British Library Year Book". Edited by ALEX. J. PHILIP. Demy 8vo. 286 pp. Price 5s. net. (Post free, 5s. 4d. home; 5s. 6d. abroad.)

THE PLUMBING, HEATING AND LIGHTING ANNUAL FOR 1911. The Trade Reference Book for Plumbers, Sanitary, Heating and Lighting Engineers, Builders' Merchants, Contractors and Architects. Including the translation of Hermann Recknagel's "Kalender für Gesundheits-Techniker," Handbook for Heating, Ventilating, and Domestic Engineers, of which Scott, Greenwood & Son have purchased the sole right for the English Language. Quarto. Bound in cloth and gilt lettered. Price 3s. net. (Post free, 3s. 4d. home; 3s. 8d. abroad.)

SCOTT, GREENWOOD & SON,

Technical Book and Trade Journal Publishers,

8 BROADWAY, LUDGATE, LONDON, E.C.

Telegraphic Address, "Printerles, Cent., London".

February, 1913.

2

ap^h - for
u. ed. ver

THIS BOOK IS DUE ON THE LAST DATE
STAMPED BELOW

AN INITIAL FINE OF 25 CENTS

WILL BE ASSESSED FOR FAILURE TO RETURN
THIS BOOK ON THE DATE DUE. THE PENALTY
WILL INCREASE TO 50 CENTS ON THE FOURTH
DAY AND TO \$1.00 ON THE SEVENTH DAY
OVERDUE.

APR 7 1946

7 Oct 55 VW

Oct 2 1956

2/10/56

JUN 15 1972 64

REC'D LD JUN 5 72 - HAM 7 3

NOV 28 1977

REC. CIR. NOV 2 '77

YC 18344

TP685

S3

273388

UNIVERSITY OF CALIFORNIA LIBRARY

