

557.09773
IL6cr 1989-1

SHALLOW GROUNDWATER RESOURCES ASSESSMENT FOR THE VILLAGE OF MONTGOMERY, ILLINOIS

Stephen S. McFadden, Craig R. Gendron, and Faith A. Stanke



Technical Completion Report
to the
Village of Montgomery

Department of Energy and Natural Resources
ILLINOIS STATE GEOLOGICAL SURVEY
1989

*Graphics: Peter M. Ryan
Editor: E. Anne Latimer*

Printed by authority of the State of Illinois/1989/150

SHALLOW GROUNDWATER RESOURCES ASSESSMENT FOR THE VILLAGE OF MONTGOMERY, ILLINOIS

Stephen S. McFadden, Craig R. Gendron, and Faith A. Stanke

ISGS CONTRACT/GRANT REPORT: 1989-1
Technical Completion Report
to the
Village of Montgomery

ILLINOIS STATE GEOLOGICAL SURVEY
Morris W. Leighton, Chief
Natural Resources Building
615 East Peabody Drive
Champaign, Illinois 61820



Digitized by the Internet Archive
in 2012 with funding from
University of Illinois Urbana-Champaign

<http://archive.org/details/shallowgroundwat19891mcfa>

CONTENTS

Abstract.....	v
Acknowledgments.....	v
Introduction.....	1
Geology of the Montgomery Area.....	2
Bedrock Geology.....	2
Glacial Drift.....	2
Methodology.....	8
Surficial Geophysical Surveys.....	8
Test Drilling.....	9
Aquifer Testing.....	9
Hydrogeology of the Montgomery Area.....	9
Deep Bedrock Aquifers.....	9
Shallow Dolomite Bedrock Aquifer.....	10
Drift Aquifers.....	12
Aquifer Testing.....	14
Summary and Conclusions.....	15
References.....	16

FIGURES

1 Location of study area.....	1
2 Elevation of the bedrock surface.....	4
3 Well and seismic survey identification and location of cross sections.....	4
4a Cross section A-A'.....	5
4b Cross section B-B'.....	5
4c Cross section C-C'.....	6
5 Isopach of the glacial drift.....	8
6 Isopach of the shallow dolomite bedrock aquifer (Silurian and upper Maquoketa Group).....	11
7 Areal distribution and thickness of shallow sand and gravel deposits.....	12
8 Areal distribution and thickness of sand and gravel deposits in buried bedrock valleys.....	13

TABLES

1 Stratigraphy and water-yielding properties of the bedrock units in northeastern Illinois.....	3
2 Stratigraphy and water-yielding properties of the drift (Quaternary) deposits in northeastern Illinois.....	7

ABSTRACT

Because of declining water levels and high radium content in water from deep bedrock sandstone aquifers, the Village of Montgomery is interested in developing alternate water sources to meet future needs. Shallow aquifers in the glacial drift and upper bedrock are among the sources being considered. Geologic mapping of the shallow aquifers in the Montgomery area was completed using existing records, surficial geophysical methods, and test drilling. Sand and gravel deposits within buried bedrock valleys, which form the lower sand and gravel aquifer, have been identified as a preferred environment for shallow groundwater exploration. An accurate bedrock topography map is therefore a valuable tool for exploration. A narrow, sinuous bedrock valley was mapped in the Montgomery area. Test drilling and aquifer testing demonstrated that the lower sand and gravel aquifer within this bedrock valley can supply 1.0 to 1.3 mgd (million gallons per day) in Montgomery. Additional shallow groundwater resources are present in an unconfined sand and gravel aquifer, the upper sand and gravel aquifer, and in the upper fractured dolomite bedrock. Areal distribution of the upper sand and gravel aquifer is extensive, but this source may be susceptible to contamination and seasonally variable yields. The yield of the fractured dolomite is highly variable and locating productive areas is difficult. Maps prepared as part of this study will aid further exploration and development of shallow groundwater resources.

ACKNOWLEDGMENTS

The authors thank the many people who contributed to the success of this study. Richard Young of the Kane County Environmental Department has supported the regional study since its inception. John Moore of the Village of Montgomery enthusiastically contributed to the work in Montgomery.

The study could not have been completed without the help of several ISGS employees. Robert Gilkeson was instrumental in initiating the regional and local studies in Kane County. Doug Cantwell, Walter Morse, Phillip Orozco, Steve Padovani, and Charles Tindell conducted the field work under the direction of Doug Laymon. John Skinner and Cheryl Wegscheid assisted in the preparation of maps and figures in this report. Ms. Wegscheid also typed a draft of the text. Brandon Curry described lithologic samples and correlated the lithologic units to regional glacial stratigraphy.

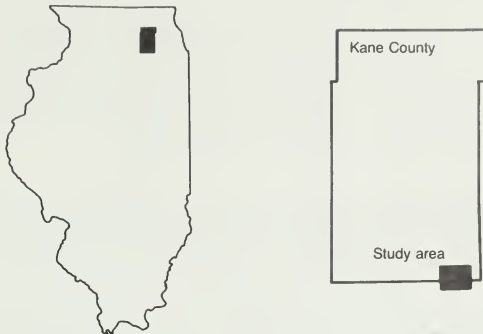

Figure 1 Location of study area.

INTRODUCTION

The Village of Montgomery has traditionally relied on sandstone aquifers of Cambrian and Ordovician age to supply most of its water needs. However, because of declining water levels caused by overpumping and concerns about the water quality in deep sandstone bedrock aquifers, the village is interested in exploring for shallow groundwater resources in the area. These include sand and gravel aquifers within the glacial drift and shallow bedrock aquifers.

Regionally, the deep bedrock aquifers in Kane County (Cambrian and Ordovician sandstones) produce water having radium concentrations exceeding U. S. Environmental Protection Agency (US EPA) standards for safe drinking water. Barium concentrations in water from the deep bedrock aquifers also exceed the US EPA drinking-water standards in northeastern Kane County. High chloride concentrations in water produced from the lower part of the Mt. Simon Sandstone, the lowest member of the Cambrian-Ordovician bedrock aquifer system, are also of concern. For Montgomery, which is located in southern Kane County and has no wells extending into the Mt. Simon, the primary concern is to locate shallow groundwater resources that are low in radium yet adequate to supply future needs.

The investigation in Montgomery (fig. 1) is an extension of a comprehensive regional examination of shallow groundwater resources in Kane County currently being conducted by the Illinois State Geological Survey (ISGS) and Illinois State Water Survey (ISWS). The purpose of the county-wide program is to investigate the possibility of large shallow groundwater resources in Kane County and to establish the regional geologic framework of the aquifers. The regional program has established that large resources are available, but it was not intended to define the optimal development of the shallow groundwater resources for individual communities in the county. Development of the resources locally requires detailed geologic mapping, test drilling, and aquifer testing.

The study was conducted in three phases. First, the ISGS conducted surficial geophysical surveys to explore for specific geologic environments favorable for shallow aquifer development. The geophysical surveys were guided by existing geologic knowledge of the area. Second, data from the geophysical surveys were used to locate test drilling sites. Samples collected during the drilling operation and natural gamma ray logs of the test holes were used to characterize the geologic materials present at the site. Third, aquifer tests were designed based on the results of test drilling, and conducted to evaluate aquifer properties. This report includes the first two phases involving geological investigation of shallow aquifers in the Montgomery area. The third phase, aquifer testing, conducted by the ISWS as part of the regional investigation in Kane County, will be discussed in a separate report to the county.

GEOLOGY OF THE MONTGOMERY AREA

Montgomery is located in southern Kane County in northeastern Illinois (fig. 1). Two different stratigraphic sequences lying on crystalline Precambrian basement characterize the geology of this area. Paleozoic time (from 570 million to 245 million years ago) is represented by a series of rocks of marine origin. Unconsolidated sediments deposited during the Quaternary (1.6 million to about 10,000 years ago) overlie the Paleozoic rocks. These sediments consist of a lithologically complex series of gravels, sands, silts, and clays representing a variety of depositional environments associated with several advances and retreats of glacial ice.

Bedrock Geology

In northern Illinois, Cambrian- through Pennsylvanian-age rocks of the Paleozoic Era are dominantly of marine origin. This stratigraphic sequence dips generally south to southeast. In the Montgomery area, Cambrian, Ordovician, and Silurian units of the Paleozoic (570 million to about 410 million years ago) reach a total thickness of about 4000 ft (table 1). Alternating layers of sandstone, shale, limestone, and dolomite occur in varying thicknesses. The Cambrian and Ordovician sandstones of this sequence are the major bedrock aquifers of the region, with the overlying limestone and dolomite layers of Silurian and of the upper Ordovician-age Maquoketa Group locally supplying significant quantities of water. Buschbach (1964) and Visocky et al. (1985) provide a more detailed description of the geology of Paleozoic units in northern Illinois. The Ironton and Galesville Sandstones are the subject of a study by Emrich (1966), while Willman and Kolata (1978) and Kolata and Graese (1983) report on the regional geology of the Platteville and Galena Groups. Willman (1971) also reports on the geology of the Chicago area including eastern Kane County. The upper bedrock sequence in Kane County (Galena-Platteville, Maquoketa, Silurian) is the subject of an investigation for siting of the Superconducting Super Collider, as reported by Kempton et al. (1985, 1987), and Graese et al. (1988).

Figure 2 is a map of the topography of the bedrock surface in the study area. This surface was mapped statewide by Horberg (1950) and in Kane County by Gilkeson and Westerman (1976), Wickham et al. (1988), and Graese et al. (1988). These maps do not provide sufficient detail for local groundwater exploration. Figure 2 was prepared using existing maps and well data with local detail provided by seismic refraction surveys and test drilling. The location of wells and seismic lines are shown to indicate the data control on this surface.

The bedrock surface under Montgomery can be divided into two areas, each with distinct topographic character: 1) bedrock uplands at elevations above 600 ft to about 660 ft and 2) a bedrock valley at elevations from 600 ft to about 540 ft. The bedrock valley, herein referred to as the Aurora Bedrock Valley, was a drainage system developed on the bedrock surface that is now filled with glacial drift. The Aurora Bedrock Valley enters Montgomery from the northwest and continues under the Fox River east of Montgomery into Aurora. The Aurora Bedrock Valley branches into two tributary valleys at the eastern edge of the map in figure 2. These valleys have been mapped to the northeast and southeast of the study area. The valley is relatively narrow, ranging from several hundred to about 1300 ft wide in the Montgomery area. Valley walls are relatively steep, with bedrock elevations below 560 ft at the center of the valley. These valley centers are sinuous and narrow.

The bedrock surface is further illustrated in cross sections (figs. 3 and 4). Section A-A' through the Montgomery area shows the localized nature of the Aurora Bedrock Valley in the perspective of the regional bedrock surface. Section B-B' generally follows the strike of the Aurora Bedrock Valley and further illustrates the relationship of this localized bedrock feature to the regional bedrock surface. Section C-C' is a detailed cross section in the area where the Aurora Bedrock Valley crosses under the Fox River. This area was developed as a shallow groundwater resource from information provided by detailed seismic surveying, test drilling, and well logging.

Glacial Drift

Several hundred million years of the rock record--from the youngest bedrock (Silurian) present under Montgomery to the oldest glacial materials--are missing. This gap represents periods of nondeposition and erosion. It was on this erosional surface that the earliest Pleistocene glaciers advanced into the area. Alternate advances and retreats of glacial ice created a variety of deposi-

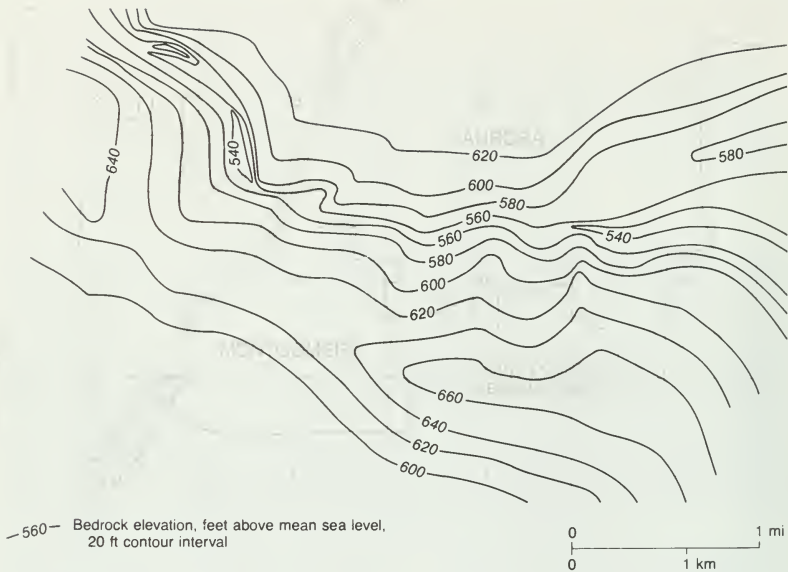

Figure 2 Elevation of the bedrock surface.

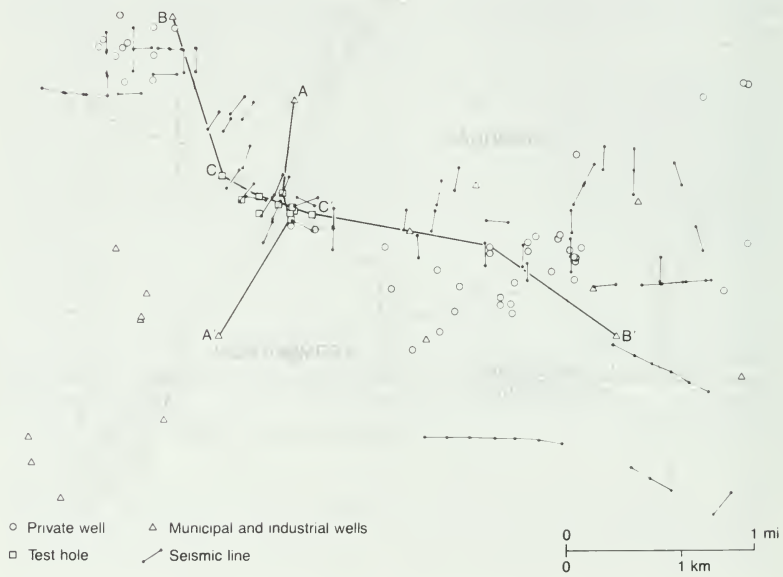

Figure 3 Well and seismic survey identification and location of cross sections.

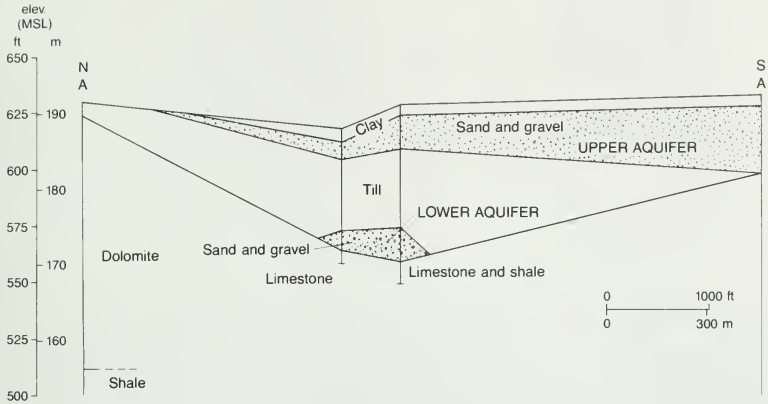

Figure 4a Cross section A-A' across the Aurora Bedrock Valley, along the Fox River.

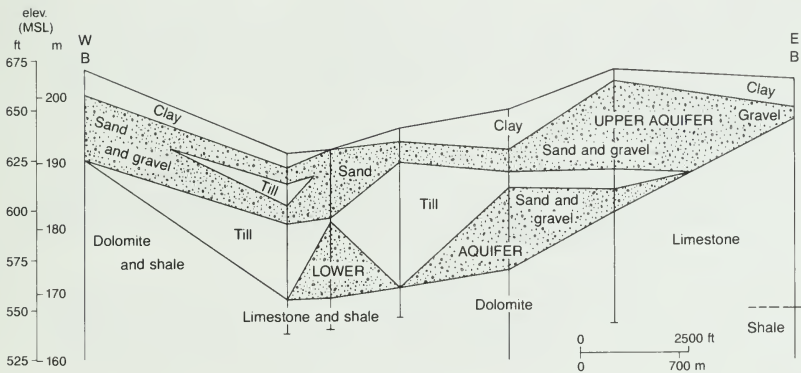

Figure 4b Cross section B-B' illustrating the variability of the glacial deposits.

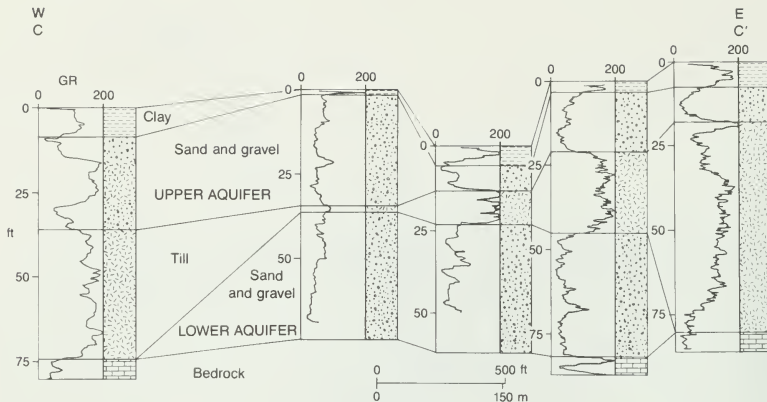

Figure 4c Cross section C-C' along the Aurora Bedrock Valley, with natural gamma ray configurations.



















tional environments resulting in a complex geometry of lithologies. Active glaciers deposited till, sediment with a bimodal combination of varying amounts of coarse material (boulders, gravel), in a fine-grained matrix of sand, silt, and clay. Glacial meltwater deposited sand and gravel in existing bedrock valleys. The valleys became dammed at times by glacial ice or debris, resulting in a lake environment in which silt and clay layers were deposited. Subsequent advances and retreats of the ice margins modified the original extent and thickness of the older glacial deposits and complicate the interpretation of the thickness and lateral extent of the deposits. Since the retreat of the most recent glaciers from the area about 14,000 years ago, glacial deposits have been further modified by fluvial erosion and deposition including the Fox River and its tributaries.

Table 2 illustrates the succession of Quaternary glacial deposits in northeastern Illinois. In the Montgomery area, most glacial sediments were deposited during the Illinoian and Wisconsinan Stages. Sand and gravel deposits and till belonging to the Glasford Formation of Illinoian age are found in buried bedrock valleys (see cross sections in fig. 4). The till is generally compact, bouldery sandy loam. Preliminary work suggests it is the Fairdale or Herbert Till Members of Berg et al. (1985). The Yorkville Till Member of the Wedron Formation of Wisconsinan age forms the bulk of materials overlying the Glasford Formation in the buried bedrock valleys and the Silurian dolomite outside the valleys. A shallow sand and gravel deposit within the Wedron Formation is areally extensive in the Montgomery area. Cross sections B-B' and C-C' in figure 4 illustrate the variable thickness of the upper and valley-fill sand and gravel units as well as that of the till layer which separates them.

Figure 5 is an isopach (thickness) map of the glacial drift in the Montgomery area. Because land surface is relatively flat, except along the Fox River valley, the variation in glacial drift thickness is mainly related to the buried bedrock topography outside the Fox valley. The thickest glacial drift (140 ft) is within the Aurora Bedrock Valley outside the present Fox River valley. The thinnest drift is present in areas where the bedrock surface elevation approaches ground surface along the Fox River valley (compare figs. 2 and 5).

The cross sections in figure 4 illustrate the relationship of the Fox River to the glacial deposits and bedrock surface. The Fox River has cut into the till of the Wedron Formation over the Aurora Bedrock Valley, whereas in areas of high bedrock surface elevation, the Fox River has cut into bedrock. Outcrops of Silurian dolomite can be seen in the Fox River valley and its tributary valleys in the area.

Table 2 Stratigraphy and water-yielding properties of the drift (Quaternary) deposits in northeastern Illinois (modified from Curry et al., 1988)

SYSTEM	SERIES	STAGE	Formation Member	Graphic Log	Genetic Interpretation of Materials and Description	Hydrostratigraphic Units	Water-Yielding Properties		
QUATERNARY	HOLOCENE		Cahokia Fm		Alluvium — sand, silt, and clay deposited by streams	PRAIRIE AOUIGROUP	Generally, sand and gravel units within Wisconsinan glacial drift and, locally, Holocene fluvial deposits. Variable areal extent, thickness (0-150 ft), and yield (0 to greater than 1,000 gpm). Locally interconnected with the Lower Sand and Gravel aquifer and/or Shallow Dolomite Bedrock aquifer. Locally confined above by tills and/or below by tills or bedrock of low permeability.		
			Grayslake Peat		Peat and muck, often interbedded with silt and clay				
	PLEISTOCENE		WISCONSINAN	Richard Loess				Loess — windblown silt and clay	Upper Sand and Gravel aquifer
				Equality Fm				Lake deposits — stratified silty clay and sand	
				Henry Fm				Outwash — sand and gravel	
				Wadsworth				Till — yellowish brown to gray silty clay loam	
				Haeger				Till — yellowish brown loam; extensive, thick basal sand and gravel	
				Yorkville				Till — yellowish brown to gray silty clay loam	
				Malden				Till — yellowish brown to brownish gray loam to clay; extensive basal sand and gravel west of the Fox River	
				Tiskilwa				Till — pinkish brown or grayish brown clay loam	
				Pedicular Fm				Lake deposits — pinkish brown to gray stratified sand, silt and clay	
				Roben Silt				Banded soil developed into alluvium, colluvium or bog deposits — organic rich silt, sand and clay	
				Berry Clay				Accretion-gley — clay, silt and sand	
				Pearl Fm				Outwash — sand and gravel	
ILLINOIAN		GLASTON Fm	Esmond		Till — gray silty loam	Lower Sand and Gravel aquifer	Generally, bedrock, valley-fill sand and gravel of limited areal extent and thickness (0-200 ft) and variable yield (0 to greater than 1,500 gpm). Locally interconnected with the Shallow Dolomite Bedrock aquifer and/or Upper Sand and Gravel aquifer. Locally confined above by till and/or below by bedrock of low permeability.		
			Oregon		Till — light brown to pink sandy loam and loam				
			Fairdale		Till — brown loam to clay loam				
			Herbert		Till — pink sandy loam, locally contains boulders				
			Kellerville		Till — brown loam				

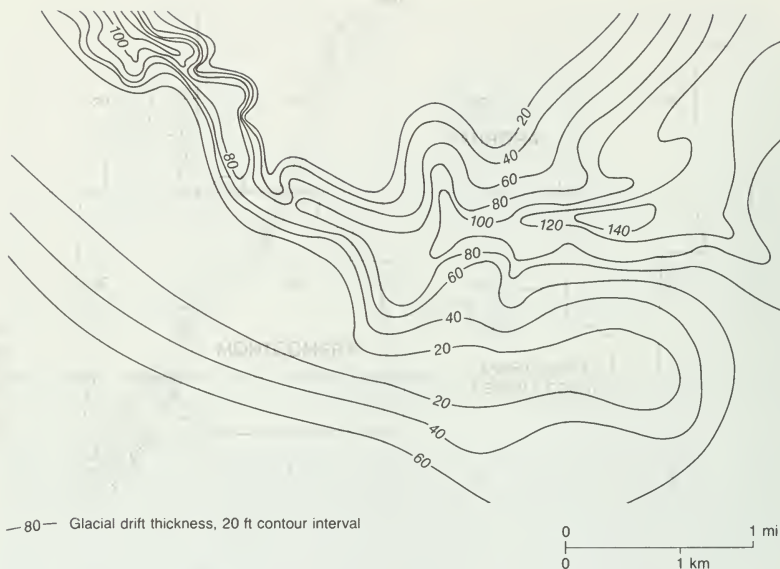

Figure 5 Isopach of the glacial drift.

For a more detailed description of glacial history of the Montgomery area and northeastern Illinois, see Kempton et al. (1985), Gilkeson and Westerman (1976), and Wickham et al. (1988).

METHODOLOGY

Surficial Geophysical Surveys

The regional study of Kane County has shown that buried bedrock valleys are favorable environments for the occurrence of shallow sand and gravel aquifers. Some bedrock valleys actually were drainage ways for glacial meltwater heavily laden with glacially derived sediment, a depositional environment favorable for thick accumulations of sand and gravel. Particularly productive environments for groundwater development are areas where sand and gravel deposits in the glacial drift are in contact with fractured bedrock. Therefore, an accurate large-scale map of the bedrock surface is of great value in shallow groundwater exploration.

Existing literature and well records were examined before field work was done to guide the geophysical surveying. The researchers also reviewed publications on the hydrogeology of Kane County and northeastern Illinois. Well records of the area on file at the ISGS and ISWS provided information on shallow hydrogeology. Locations of wells were verified at the Kane County Building Permit Office. Complete and accurate records of test holes drilled during a shallow groundwater investigation for the City of Aurora, which borders Montgomery to the north, were particularly useful.

A surficial geophysical method, seismic refraction, was used for detailed bedrock topography and drift thickness mapping. A high degree of accuracy (plus or minus 5 ft) in determining drift thickness and bedrock topography is possible because of the velocity contrast between glacial materials and the bedrock of this area. Reversed profile seismic data were gathered using a 24-

channel signal enhancement seismograph. Buried explosive charges or a mechanical weight drop system were used to produce the seismic signal. The field data were processed automatically with a modification of a ray tracing program (SIPT-1) written by the U. S. Bureau of Mines (Scott et al., 1972). An interactive data entry program (DIRT) written by Laymon (1986) permitted efficient entry of field data into the SIPT-1 program. The SIPT-1 program corrects for irregular surface terrain along the seismic profile and also calculates the depth to bedrock beneath each geophone. For the drift thickness in the Montgomery area, a 50-foot geophone spacing provided sufficient detail of the bedrock surface to delineate areas for test drilling.

The seismic refraction method accurately defines the depth to bedrock except in areas where thick sand and gravel deposits are overlain by thick clay till. In this environment, a velocity inversion results because the sand and gravel deposits have a lower velocity than the overlying till (Zohdy et al., 1974). Where a thick basal sand and gravel layer in a bedrock valley is confined by a higher velocity clay till, the solution of the reversed seismic profiles through the valley indicates an anomalously great depth to bedrock. The anomalies are potential targets for groundwater resource evaluation.

A second surficial geophysical method, electrical earth resistivity, can be used to investigate the nature of the geologic materials present in the drift. In freshwater environments, sand and gravel deposits have a higher resistance than clay-rich, fine-grained deposits. While this method has been used extensively in the regional study, it was of limited value in the Montgomery area because of interference caused by the dense or closely spaced cultural features. A more complete description of the regional study is in Gilkeson et al. (1987).

Test Drilling

After identifying favorable areas using the surficial geophysical methods, 11 test drills (see fig. 3) were conducted. Drilling verified the presence of aquifer materials, assisted in stratigraphic correlation, and provided information for the design of an aquifer test and production well. Test hole drilling, performed with mud rotary equipment, provided wash cuttings and split-spoon samples at selected intervals. The lithology of the cuttings and spoon samples were described. Sand and gravel samples were sieved to provide information for the design of pumping wells. Generally, the wells extended 10 ft into the bedrock to determine the shallow bedrock lithology and the exact location of the drift-bedrock contact. The wells were completed with 3-inch PVC casing and slotted pipe opposite the aquifer interval, permitting the use of the holes as observation wells during aquifer testing. The holes were logged using a downhole natural gamma tool to distinguish clay-rich tills from relatively clean sand and gravel layers. The data from the lithologic and natural gamma logs assisted in mapping the thickness and areal extent of shallow aquifers.

Aquifer Testing

An aquifer test, the final phase of investigation, is conducted if test drilling confirms the presence of aquifer materials of sufficient thickness for a municipal well. Aquifer testing provides information on the yield of the aquifer at that location, long-term production rates, aquifer flow boundaries, and optimal spacing of additional production wells to minimize interference.

The ISWS designed the aquifer tests, using information from geologic mapping and test drilling, to determine the number and location of observation wells and the rate and duration of pumping. ISWS conducted and interpreted the results of the aquifer tests. A detailed description of the equipment and methods used in this phase of the regional investigation will be covered in a report in preparation for Kane County.

HYDROGEOLOGY OF THE MONTGOMERY AREA

Deep Bedrock Aquifers

A major source of drinking water for the Village of Montgomery and other municipalities in northern Illinois is the deep bedrock sandstone aquifers of the Cambrian and Ordovician Systems (Midwest Bedrock Aquifer group of Visocky et al., 1985). Most of the water pumped from wells completed in this sequence is produced from the Ironton and Galesville Sandstones of Cambrian age and the St. Peter Sandstone of Ordovician age (table 1). Typically, wells are constructed with casing through the Maquoketa Group or the underlying Galena and Platteville Groups, and finished as

an open-hole in the Galesville Sandstone. Some deeper wells in Kane County (1400 ft or greater) also produce water from the Mt. Simon Sandstone of Cambrian age. Woller and Sanderson (1978) describe many Kane County public water supply wells. Discussions of bedrock aquifers as regional flow systems are in Visocky et al. (1985), and Hughes et al. (1966).

This traditional source of water is becoming problematic in terms of quantity and quality. The deep bedrock aquifer system has been overdeveloped in northeastern Illinois, causing a widespread and deep decline in the potentiometric surface. Potentiometric levels at some pumping centers have reached 100 ft below sea level, a historical decline of several hundred feet (Sasman et al., 1982). The declines of potentiometric levels are accompanied by several problems including dewatering of the upper units of the system, declining yields, increased pumping costs, and aggravation of water quality problems. The effects of over pumping of this system in northeastern Illinois are described in greater detail in Schicht et al. (1976), Walton and Csallany (1962), Visocky et al. (1985), and Sasman et al. (1982 and 1986). The impact of continued withdrawals and the use of alternative water sources are the subject of several studies. Schicht and Moench (1971) analyzed the impact of projected future pumping. Visocky (1982) and Schicht and Adams (1977) investigated the effects of Lake Michigan allocations on the deep bedrock aquifer potentiometric surface.

In addition to declining potentiometric levels, water quality problems have raised concern over continued use of the deep bedrock aquifers. Most significantly, the Cambrian-Ordovician sandstones in northeastern Illinois produce water that exceeds the U. S. EPA limit of 5 pCi/L (US EPA, 1975) for radium in public drinking water supplies. The source of the radium is the radioactive decay of trace amounts of parent uranium and thorium in the sandstone aquifers. The occurrence and geochemistry of radium in the deep aquifers is discussed in Gilkeson et al. (1983, 1984).

The Village of Montgomery is not directly affected by two other quality problems in water from the Cambrian-Ordovician sandstone aquifers: high barium levels and high total dissolved solids. In northeastern Kane County, barium in excess of the U. S. EPA's standard of 1 mg/L (US EPA, 1975) is present in water produced from the deep sandstone aquifers (Gilkeson et al., 1981). Wells penetrating the upper Mt. Simon Sandstone have produced water high in total dissolved solids throughout Kane County. Water in the base of the Mt. Simon Sandstone is highly saline, and potentiometric declines in the upper fresh-water portion of the aquifer have apparently led to upconing of the deeper water.

Prompted mainly by declining water levels and high radium levels, Montgomery and other Kane County communities have begun to investigate alternative sources of water. These include surface water (mainly the Fox River) and shallow groundwater sources from upper bedrock and glacial drift aquifers.

Shallow Dolomite Bedrock Aquifer

Problems of declining water levels and high radium content are confined to bedrock aquifers below the Platteville Group (table 1). The shallow dolomite bedrock aquifer above the lower Maquoketa Group has not been extensively developed and produces water low in radium content. Regionally, this aquifer consists of carbonate layers within the upper part of the Maquoketa Group and Silurian formations. The Silurian is about 50 ft thick in the Montgomery area, but thins rapidly to the west and is generally absent in western Kane County (Curry et al., 1988; Graese et al., 1988). The Maquoketa also thins to the west but is approximately 150 ft thick in the Montgomery area (well S18, Curry et al., 1988; fig. 13, Kempton et al., 1985). The lower part of the Maquoketa Group is dominantly shale and regionally acts as a confining unit. The upper part, composed of limestone and dolomite interlayered with shale, locally produces significant amounts of water (well S20, Curry et al., 1988). The Silurian and upper Maquoketa form an aquifer throughout eastern Kane County and much of northeastern Illinois (part of the Upper Bedrock Aquifer of Visocky et al., 1985), although yields are highly variable. Water is produced from secondary porosity and associated permeability (fractures, weathering, and solution features) within the

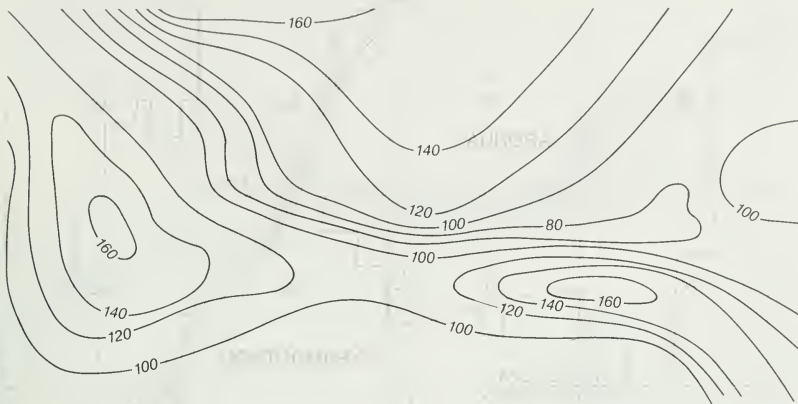

—120— Bedrock aquifer thickness, 20 ft contour interval

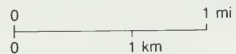

Figure 6 Isopach of the shallow dolomite bedrock aquifer (Silurian and upper Maquoketa Group).

dolomite and limestone. Where these features are well developed, yields can be quite high; more than 1000 gpm (gallons per minute) has been reported (Csallany and Walton, 1963). Wells that do not encounter these secondary porosity and permeability features are essentially dry holes.

Exploration for groundwater resources in the shallow dolomite bedrock aquifer of northeastern Illinois, where these units are overlain by glacial drift, is the subject of continued research. There is concern regarding the long-term yield of wells in this aquifer. Depending on the areal extent and degree of interconnection of secondary porosity and permeability features, the aquifer may be dewatered through long-term use. Although it is not possible to predict locations for successful wells in the shallow dolomite bedrock aquifer, some features are known which can increase the probability of a successful well. Areas where the combined thickness of Silurian and upper Maquoketa is greatest increase the probability of intersecting productive fracture systems in a drilled well. If the dolomite is overlain by a significant thickness of sand and gravel, the yield from the bedrock aquifer usually improves. The combined system apparently results in improved aquifer storage characteristics (Csallany and Walton, 1963; Gilkeson et al., 1987).

Figure 6 shows an isopach map of the shallow dolomite bedrock aquifer (Silurian and upper Maquoketa) in the Montgomery area. The most striking feature of the map is the relatively thin area associated with the Aurora Bedrock Valley. This bedrock valley may cut through the Silurian dolomite to the top of the Maquoketa Group. Coupled with maps of sand and gravel aquifers in the glacial drift (following section), this map can be used to identify areas where further exploration may result in a successful well producing from the shallow bedrock aquifer. It is important to note that in some areas the full thickness of the Silurian Dolomite units may not be productive as

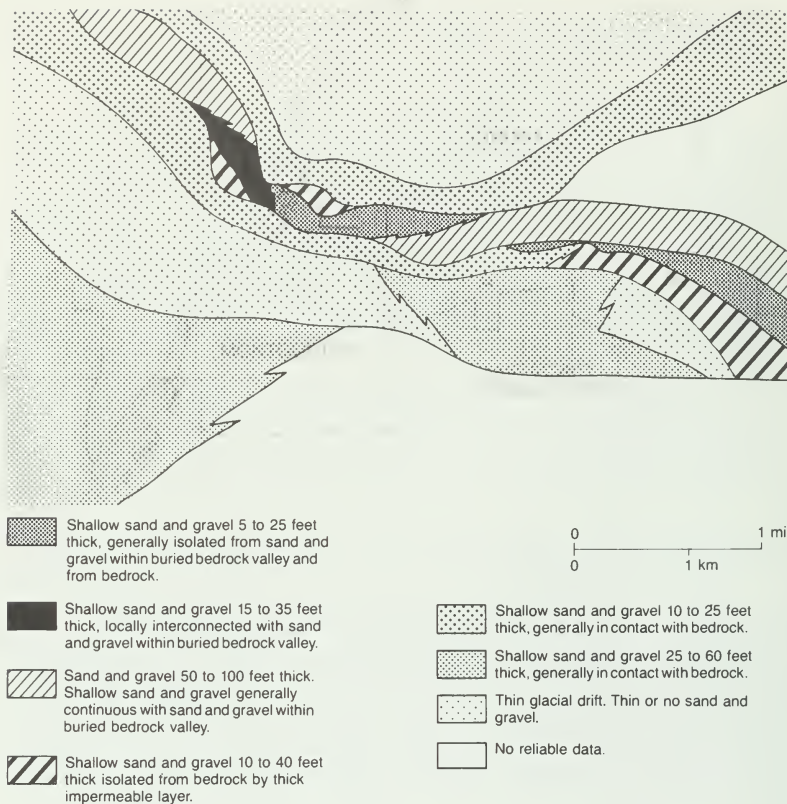

Figure 7 Areal distribution and thickness of shallow sand and gravel deposits (upper sand and gravel aquifer).

an aquifer. Packer tests performed on SSC test holes show that only about the upper 40 feet of the bedrock are very permeable (Curry et al., 1988). Other wells in the upper bedrock, however, reportedly produce water from fractures deeper in the bedrock.

Drift Aquifers

Sand and gravel deposits within the glacial drift form significant aquifers in the Montgomery area, particularly where the sand and gravel is interconnected with the shallow dolomite bedrock aquifer. Locating these aquifers has been historically a problem, as they are discontinuous and vary greatly in thickness. Surficial geophysical methods, such as seismic refraction and electrical earth resistivity, have proved useful in locating sand and gravel aquifers.

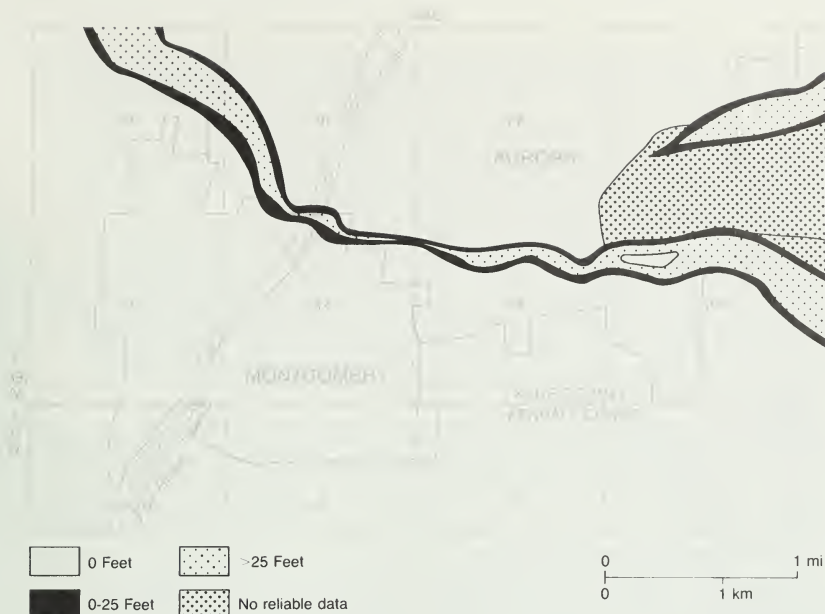

Figure 8 Areal distribution and thickness of sand and gravel deposits in buried bedrock valleys (lower sand and gravel aquifer).

Figure 7 is a map showing the distribution and thickness of shallow sands and gravels within the Wedron Formation of Wisconsinan age. These deposits generally form an unconfined aquifer in the Montgomery area, referred herein as the upper sand and gravel aquifer (table 2). Regionally, other sand and gravel units of Wisconsinan age covering bedrock upland areas also are included in the upper sand and gravel aquifer. The relationship of this aquifer to deeper glacial deposits and bedrock in the Montgomery area is complex, especially in the area of the Aurora Bedrock Valley. Over the bedrock valley, the upper sand and gravel aquifer is separated from bedrock by a valley fill composed of a till and sand and gravel (Glasford Formation, lower sand and gravel aquifer). The till is locally absent, resulting in a thick, permeable sequence where the upper and lower sand and gravel units are interconnected. The Glasford deposits pinch out near the bedrock valley walls, leaving the till directly overlying the bedrock. In these areas, the upper sand and gravel aquifer is separated from the bedrock by the till. The upper sand and gravel aquifer outside the Aurora Bedrock Valley, and, locally, at the edges of the valley, lies directly on bedrock.

While the upper sand and gravel aquifer forms an important local aquifer for domestic use, its use for public supply is limited because of its susceptibility to contamination from surface sources, variable yield (both areally and seasonally), and limited available drawdown. Locally, groundwater in this aquifer appears to discharge to the Fox River, although information from the aquifer tests in Montgomery suggests this may not be the case.

Figure 8 shows the distribution and thickness of valley-fill lower sand and gravel aquifer (Glasford Formation) at the base of the glacial drift in contact with the upper bedrock. These deposits, which are restricted to the Aurora Bedrock Valley, form the most important shallow aquifer in the Montgomery area, referred to here as the lower sand and gravel aquifer. Regionally, sand and gravel units from pre-Wisconsinan through early Wisconsinan age are included in the lower sand

and gravel aquifer (table 2). Interconnection of the lower sand and gravel aquifer with the shallow dolomite bedrock aquifer increases the areal extent and storage and recharge capacity of the shallow dolomite bedrock aquifer. The sand and gravel aquifer provides adequate transmissivity for a high-yielding public supply well (Gilkeson et al., 1987). The thickest sand and gravel sequence is present where the upper and lower sand and gravel aquifers are continuous (areas delineated in fig. 7, see also cross sections in fig. 4). It is not possible to distinguish these two sand and gravel bodies in driller's logs where they are not separated by till; therefore, the thicknesses cannot be mapped separately in areas where the till is absent.

Figures 6, 7, and 8 illustrate the shallow groundwater resources in the Montgomery area. The most significant shallow groundwater resource is thick sand and gravel of the lower sand and gravel aquifer, where it is interconnected with the shallow dolomite bedrock aquifer located in the Aurora Bedrock Valley. Outside of the Aurora Bedrock Valley, areas of thick upper bedrock units (shallow dolomite bedrock aquifer) may be explored for additional shallow sources. The upper sand and gravel aquifer can be developed for domestic use or for relatively low-yielding public supply wells where these deposits are sufficiently thick. Caution should be used in developing this last resource because of its susceptibility to surface sources of contamination.

Aquifer Testing

Three aquifer tests were conducted in the Village of Montgomery during this shallow aquifer investigation: two by the ISWS and one by village personnel. Detailed discussion of the tests is not included in this report, but they are summarized below to provide a complete description of the shallow aquifer investigation. Results of the two tests conducted by the ISWS are described in letter reports to the village (Visocky, 1987a & b), and will be discussed further in a report in preparation for Kane County as part of a regional study.

In December 1986, Montgomery well 10, screened in the lower sand and gravel aquifer east of Highway 25, was pumped continuously for 28 days while water level measurements were recorded in several observation wells. Discharge averaged about 600 gpm; specific capacity in the pumped well was 21.9 gpm/ft. Transmissivity and storage coefficients calculated from the drawdown data in the observation wells averaged 29,900 gpd/ft and 5.2×10^{-4} respectively. The results show that the aquifer responds as a leaky artesian aquifer. The bedrock valley walls did not respond as impermeable boundaries, indicating that the bedrock is fractured and is an extension of the sand and gravel aquifer. Drawdown data in shallow bedrock observation wells were difficult to interpret because local withdrawals from the shallow dolomite bedrock aquifer masked any influence of pumping well 10. Water levels in the upper sand and gravel aquifer did not appear to respond to the test, and the Fox River also did not appear to be connected to the lower sand and gravel aquifer.

In September 1987, Montgomery well 11, located on the west bank of the Fox River and screened in the lower sand and gravel aquifer within the Aurora Bedrock Valley, was pumped for eight days at a steady rate of approximately 400 gpm. Specific capacity in the pumping well was 15.7 gpm/ft; average transmissivity calculated from drawdown data in the observation wells was 28,100 gpd/ft; and the average storage coefficient was 1.6×10^{-4} . The test indicated that the aquifer is under leaky artesian conditions. Observation wells in the shallow sand and gravel responded to pumping the lower sand and gravel aquifer, proving interconnection. The storage coefficient is in the artesian range, and the loading effects of trains at a nearby railway on wells tapping the lower sand and gravel aquifer were observed. The absence of the confining till between the upper and lower sand and gravel aquifers is also illustrated by lithologic and natural gamma logs of the test holes, shown in cross section C-C' in figure 4. An observation well in the upper sand and gravel aquifer on an island in the Fox River also responded to the pumping of well 11. This suggests that the Fox River is not a flow boundary to either the upper or lower sand and gravel aquifers and little if any water is captured from the Fox River. It is hypothesized that the bed of the Fox River contains a fine-grained component in this vicinity because of a flow control dam located about 1000 ft downstream which provides an effective seal between the river and the aquifer. This test also provided information on the interference with pumping water levels that

would result if wells 10 and 11 were simultaneously pumped. If the two wells are used simultaneously, the ISWS advised maximum pumping rates of 470 gpm and 250 gpm for wells 10 and 11 respectively, to obtain equilibrium conditions.

Late in 1987, wells 10 and 11 were pumped for several weeks, with short interruptions. Water levels were monitored by village personnel. The combined yield, about 700 gpm, was in the range predicted by the ISWS analysis. Two interesting effects were noted (John Moore, personal communication). First, water levels in observation wells in the upper sand and gravel aquifer on the west side of the Fox River dropped steadily during the test, indicating that this aquifer was being dewatered in response to pumping the lower sand and gravel aquifer in the Aurora Bedrock Valley. Water levels in observation wells in the upper sand and gravel aquifer on the east side of the Fox were not affected. Second, cycling on and off of a nearby Montgomery well in the shallow dolomite bedrock aquifer did not appear to influence water levels in the sand and gravel wells. It is possible that this particular well is producing water from a fracture system not connected to the sand and gravel aquifers or that the effects of this well were masked by other withdrawals.

Chemical analyses were performed on water samples collected at both wells 10 and 11. Water produced at well 10 is high in iron (2.80 mg/L), hard (548 mg/L as CaCO₃), and high in total dissolved solids (693 mg/L). Water from well 11 has a slightly different chemistry, possibly due to the partial interconnection with an unconfined aquifer. Iron content is much lower (0.09 mg/L), hardness is 492 mg/L (as CaCO₃), and total dissolved solids concentration is 612 mg/L.

SUMMARY AND CONCLUSIONS

Because of declining water levels and high radium content in deep bedrock aquifers, the Village of Montgomery is investigating shallow aquifers (drift and upper bedrock) to help meet future needs. The geology of shallow aquifers in the Montgomery area was investigated using a comprehensive program of surficial geophysics, test drilling, and aquifer testing. Seismic refraction surveys were used to map the bedrock surface and identify areas favorable for test drilling within buried bedrock valleys. Split-spoon samples of the drift and gamma-ray logs of the test holes were used to verify the nature of geologic materials. Aquifer testing proved the yield of the aquifer.

The study identified sites for two wells in sand and gravel deposits in the Aurora Bedrock Valley. In addition, the maps and cross sections indicate potential in other areas for shallow groundwater resources, both in sand and gravel deposits and in the upper bedrock. Specific conclusions are:

- The lower sand and gravel aquifer occurs along the base of a buried bedrock valley trending roughly east-west through Montgomery. Test drilling and aquifer testing at two locations have shown this resource can sustain a yield of 1.0 to 1.3 mgd. An additional well could be located in this aquifer in the Village of Montgomery, but because of the limited area within the village there would likely be substantial interference with the existing two wells.
- The upper sand and gravel aquifer covers about 40 percent of the Montgomery area. This resource may be used for relatively small amounts of water, but may be susceptible to contamination. Well yields vary areally and seasonally, and available drawdown is limited.
- The shallow dolomite bedrock aquifer, present in the Silurian formations and upper Maquoketa Group, forms an additional shallow groundwater resource in the area. Yields of wells from this aquifer are highly variable, and locating productive areas is difficult. An isopach map of these units shows the thickness in the Montgomery area is affected primarily by the presence of the Aurora Bedrock Valley. Areas where these units are thick and overlain by a substantial thickness of sand and gravel in the glacial drift would be preferred locations for further exploration of this resource.

REFERENCES

- Berg, R. C., J. P. Kempton, L. R. Follmer, and D. P. McKenna, 1985, Illinoian and Wisconsinan stratigraphy and environments in northern Illinois: The Altonian revised, Midwest Friends of the Pleistocene, 32nd Field Conference: Illinois State Geological Survey Guidebook 19, 177 p.
- Buschbach, T. C., 1964, Cambrian and Ordovician strata of northeastern Illinois: Illinois State Geological Survey Report of Investigation 218, 90 p.
- Csallany, Sandor, and W. C. Walton, 1963, Yields of shallow dolomite wells in northern Illinois: Illinois State Water Survey Report of Investigation 46, 43 p.
- Curry, B. B., A. M. Graese, M. J. Hasek, R. C. Vaiden, R. A. Bauer, D. A. Schumacher, K. A. Norton, and W. G. Dixon, Jr., 1988, Geological-geotechnical studies for siting the Superconducting Super Collider in Illinois: results of the 1986 test drilling program: Illinois State Geological Survey Environmental Geology Notes 122, 108 p.
- Emrich, G., 1966, Ironton and Galesville (Cambrian) sandstones in Illinois and adjacent areas: Illinois State Geological Survey Circular 403, 55 p.
- Gilkeson, R. H., E. C. Perry, Jr., and K. Cartwright, 1981, Isotopic and geologic studies to identify the source of sulfate in groundwater containing high barium concentrations: University of Illinois Water Resources Center Report UILU-WRC-81-0165, 30 p.
- Gilkeson, R. H., K. Cartwright, J. B. Cowart, and R. B. Holtzman, 1983, Hydrogeology and geochemical studies of selected natural radioisotopes and barium in groundwater in Illinois: Water Resources Center Report No. 83-0180, University of Illinois at Urbana-Champaign, Illinois, 93 p., Illinois State Geological Survey/Grant Report 1983-6, 93 p.
- Gilkeson, R. H., E. C. Perry, Jr., and R. B. Holtzman, 1984, Isotopic studies of natural sources of radium in groundwater in Illinois: Water Resources Center Report No. 84-187, University of Illinois at Urbana-Champaign, Illinois, 50 p.
- Gilkeson, R. H., S. S. McFadden, D. E. Laymon, and A. P. Visocky, 1987, Hydrogeological evaluation of groundwater resources in buried bedrock valleys, northeastern Illinois: in Focus Conference on Midwestern Ground Water Issues, NWWA, pp. 145-167.
- Gilkeson, R. H., and A. A. Westerman, 1976, Geology for planning in Kane County: Illinois State Geological Survey Open File Report prepared for the Northeastern Illinois Planning Commission, 41 p.
- Graese, A. M., R. A. Bauer, B. B. Curry, R. C. Vaiden, W. G. Dixon, Jr., and J. P. Kempton, 1988, Geological-geotechnical studies for siting the Superconducting Super Collider in Illinois: Regional summary: Illinois State Geological Survey Environmental Geology Notes 123.
- Horberg, C. L., 1950, Bedrock topography in Illinois: Illinois State Geological Survey Bulletin 73, 111 p.
- Hughes, G. M., Paul Kraatz, and R. A. Landon, 1966, Bedrock aquifers of northeastern Illinois: Illinois State Geological Survey Circular 406, 15 p.
- Kempton, J. P., R. C. Vaiden, D. R. Kolata, P. B. DuMontelle, M. M. Killey, and R. A. Bauer, 1985, Geological-geotechnical studies for siting the Superconducting Super Collider in Illinois: Preliminary geological feasibility report: Illinois State Geological Survey Environmental Geology Notes 111, 63 p.
- Kempton, J. P., R. A. Bauer, B. B. Curry, W. G. Dixon, A. M. Graese, P. C. Reed, M. L. Sargent, and R. C. Vaiden, 1987, Geological-geotechnical studies for siting the Superconducting Super Collider in Illinois: results of the fall 1984 test drilling program: Illinois State Geological Survey Environmental Geology Notes 117, 102 p.
- Kolata, D. R., and A. M. Graese, 1983, Lithostratigraphy and depositional environments of the Maquoketa Group (Ordovician) in northern Illinois: Illinois State Geological Survey Circular 528, 49 p.
- Laymon, D. E., 1986, DIRT (Data input for seismic refraction-analysis techniques): Illinois State Geological Survey Unpublished Open File Report, 8 p.
- Sasman, R. T., C. R. Benson, R. S. Ludwigs, and T. L. Williams, 1982, Water-level trends, pumpage, and chemical quality in the deep sandstone wells in northern Illinois: Illinois State Water Survey Circular 154.

- Sasman, R. T., R. S. Ludwigs, C. R. Benson, and J. R. Kirk, 1986, Water-level trends and pumpage in the Cambrian and Ordovician aquifers in the Chicago Region, 1980-1985: Illinois State Water Survey Circular 154, 47 p.
- Schicht, R. J., and J. R. Adams, 1977, Effects of proposed 1980 and 1985 lake water allocation in the deep sandstone aquifer in northeastern Illinois: Illinois State Water Survey Contract Report 188, 16 p.
- Schicht, R. J., and A. F. Moench, 1971, Projected ground water deficiencies in northeastern Illinois, 1980-2020: Illinois State Water Survey Circular 101, 22 p.
- Schicht, R. J., J. R. Adams, and J. B. Stall, 1976, Water resources availability, quality, and cost in northeastern Illinois: Illinois State Water Survey Report of Investigation 83, 90 p.
- Scott, J. H., B. L. Tibbetts, and R. G. Burdick, 1972, Computer analysis of seismic refraction data: Bureau of Mines, R17595, 99 p.
- U. S. Environmental Protection Agency, 1975, National primary drinking water regulations: Federal Register, December 24, 1975, v. 40, 248 p.
- Visocky, A. P., 1982, Impact of Lake Michigan allocation on the Cambrian-Ordovician aquifer system: Illinois State Water Survey Contract Report 292, 36 p.
- Visocky, A. P., 1987a, Unpublished letter report to the Village of Montgomery on aquifer test results on well 10: Illinois State Water Survey.
- Visocky, A. P., 1987b, Unpublished letter report to the Village of Montgomery on aquifer test results on well 11: Illinois State Water Survey.
- Visocky, A. P., M. G. Sherrill, and Keros Cartwright, 1985, Geology, hydrogeology, and water quality of the Cambrian and Ordovician systems in northern Illinois: Illinois State Geological Cooperative Groundwater Report 10, 136 p.
- Walton, W. C., and Sandor Csallany, 1962, Yields of deep sandstone wells in northern Illinois: Illinois State Water Survey Report of Investigation 43, 47p.
- Wickham, S. S., W. H. Johnson, and H. D. Glass, 1988, Regional geology of the Tiskilwa Till Member, Wedron Formation, northeastern Illinois: Illinois State Geological Survey Circular 543, 35 p.
- Willman, H. B., 1971, Summary of the geology of the Chicago area: Illinois State Geological Survey Circular 460, 77 p.
- Willman, H. B., and D. R. Kolata, 1978, The Platteville and Galena Groups in northern Illinois: Illinois State Geological Survey Circular 502, 75 p.
- Woller, D. M., and E. W. Sanderson, 1978, Public groundwater supplies in Kane County: Illinois State Water Survey Bulletin 60, 92 p.
- Zohdy, A. A. R., G. P. Eaton, and D. R. Mabey, 1974, Application of surface geophysics to groundwater investigations: Techniques of Water-Resources Investigations of the USGS, Chapter D1, Book 2, 116 p.

